

OB1203 Certification Preparation, Setup, and Test Procedure

Overview

SpO2 measurements are affected by two variations in the human body. The first is skin color. The second is the blood perfusion, which causes optical modulation and varies based on the person’s temperature and health. Changes in these variants affect SpO2 measurements.

In this pre-calibration test procedure, both of these variables are simulated and the oximeter output is monitored. Renesas provides test stimuli simulating various conditions that represent the majority of the human population. Therefore, a successful execution in the actual human subject testing certification testing can be assumed.

Contents

1. Test Purpose	2
2. Required Equipment.....	2
3. Preparation of Test Equipment	2
3.1 WhaleTeq AECG100 Hardware and Software Setup.....	2
3.2 Opto-mechanical Test Fixture	3
3.2.1. Preparing the Opto-mechanical Test Adapter.....	3
3.2.2. Mounting the Reference Board and Opto-mechanical Test Adapter.....	5
4. Reference Board Setup and Preparation	6
5. Test Setup Calibration using the Reference Board	9
5.1 Initial Setup of the AECG100 Tester	10
5.1.1. Calibration of Opto-mechanical Test Fixture.....	10
6. DUT Determination and Correction of SpO2 Errors Induced by External Optical Crosstalk	11
6.1 Background.....	11
6.2 Methods	11
6.3 Crosstalk Correction Validation	13
7. DUT – Dark Skin Sensitivity and Low Perfusion Limit Determination	14
7.1 Dark Skin Sensitivity Test.....	14
7.2 Determination of the Minimum Signal Strength Threshold.....	15
7.3 SP02 Saturation Value Test before Calibration.....	16
7.4 Sp02 Saturation Validation	17
7.5 Test Report Generation	17
8. Human Calibration Test	17
9. Revision History	18

1. Test Purpose

Customers who desire to obtain regulatory certification for their product equipped with Renesas' OB1203 will need to perform human subject testing. Since these tests are time consuming and complex, it is best to prepare by performing pre-setup and pre-tests dry runs.

This document describes the following required steps for a successful completion:

1. Collecting the required equipment
2. Preparation of measurement
3. Test setup calibration
4. Test data collection
5. R-curve generation based on data collected
6. Validation test using the test setup
7. Creation of measurement threshold

2. Required Equipment

- WhaleTeq AECG100 with 940nm test head
 - WhaleTeq AECG100 GUI installed
- OB1203SD-RL-EVK Heart Rate, SpO₂, and Respiration Rate Evaluation kit (reference board).
 - With installed calibration software
 - Renesas E2 or E2 Lite programmer including programming software
 - Renesas E2 or E2 Lite to OB1203SD-RL-EVK programming adapter board
- Renesas opto-mechanical test adapter with inserted Aluminum reflector cone
- The device under test – DUT

3. Preparation of Test Equipment

3.1 WhaleTeq AECG100 Hardware and Software Setup

Follow the [WhaleTeq documentation](#) to complete the setup and proceed to the next step.



Figure 1. SP02 Test Setup with WhaleTeq AECG100



Figure 2. WhaleTeq AECG100 Tester with PPG Module Attached

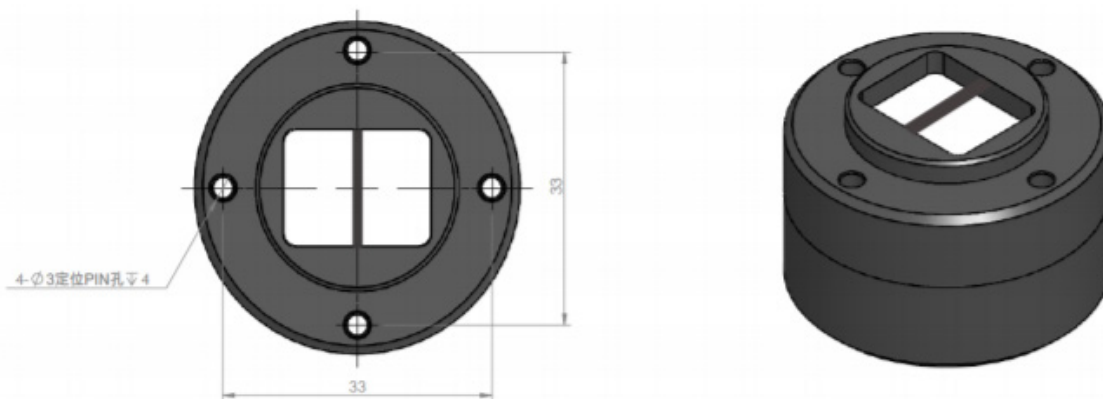

Figure 3. Mechanical Drawing of Fixture Base PPG-2R

3.2 Opto-mechanical Test Fixture

3.2.1. Preparing the Opto-mechanical Test Adapter

In order to optically and mechanically couple the OB1203SD-RL-EVK reference board and the DUT to the WhaleTeq test head, it is required to provide a stable, reliable, and repeatable adapter. This adapter ensures that the test procedure can be followed successfully and to achieve repeatable test results that support the requirements of this procedure. Renesas has created a universal test adapter that can be machined or 3D printed. For more details, please see below.

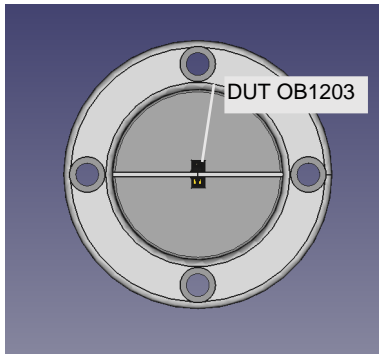

Figure 4. Top View of the OB1203 to WhaleTeq Test Adapter

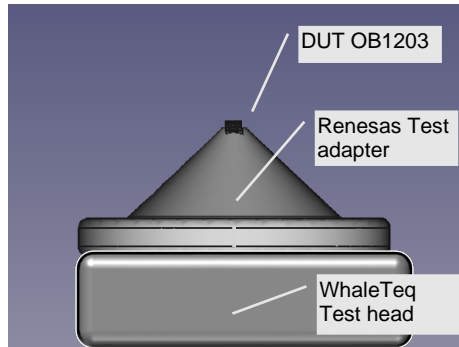

Figure 5. Side View of OB1203 to WhaleTeq Test Adapter

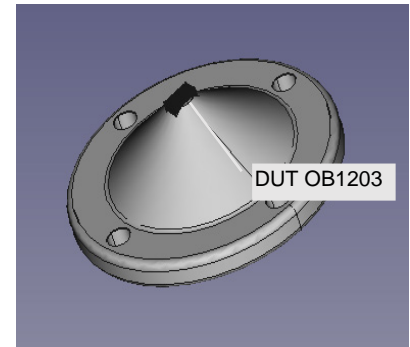

Figure 6. Perspective View of OB1203 to WhaleTeq Test Adapter

The 3D stl file can be printed on a 3D printer (see [OB1203SD-RL-EVK](#) webpage for file).

It is also required to apply (at least on one side of the test adapter) a reflective insert ensuring acceptable optical performance, and at the same time, eliminating uncertainty from the print quality and/or material properties. It has been determined that aluminum foil is a good material for this purpose, and Renesas has provided an applicator to insert the foil properly. This applicator can also be 3D printed.

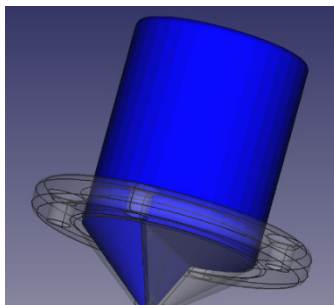

Figure 7. Illustration of Applicator Inserted into Test Adapter

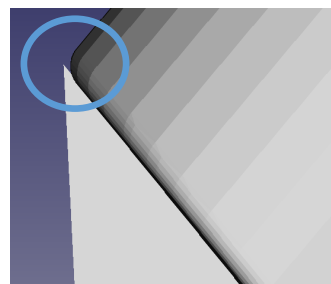

Figure 8. Illustration of Cutting Groove

Procedure to Insert the Aluminum Foil Using the Applicator

1. Use an appropriately sized piece of Aluminum foil and wrap it around the pointed end of the applicator in a single ply.
2. Insert the Aluminum foil into one cavity of the adapter making sure the applicator fits snugly into the cavity – use firm but light pressure.
3. Remove the applicator *and* the Aluminum foil from the cavity.
4. Use a sharp knife and cut off the excess of the Aluminum foil just above the cone – there should be a small cutting groove to assist a straight cut (see Figure 8 image on top left).
5. Apply a thin layer of glue to the outside of the Aluminum foil and re-insert the Aluminum foil using the applicator tool.
6. This time, remove the applicator leaving the Aluminum foil behind in the cavity. It should be held in place by the glue.
7. Using a small tool, clear the optical opening at the tip of the adapter of the Aluminum foil and 3D print material ensuring an un-obstructed path for the optical signal.

Note: The cavity with the Aluminum foil should be used on the Photo Detector receiver side of the DUT and the LED side of the WhaleTeq test head to collect the maximum light possible and funnel it into the DUT receiver.

3.2.2. Mounting the Reference Board and Opto-mechanical Test Adapter

The fixture is machined or printed as required to fit the case of the DUT, aligning the cross bar in the fixture with the center of the OB1203, and not blocking the LEDs or detector. The fit must exclude external light. The DUT must be mechanically aligned and securely mounted to the fixture.

3.2.2.1. Opto-Mechanical Test Head Stack Up

1. Top: OB1203 Device Under Test.

The DUT must be mechanically attached and stable so that it cannot move.

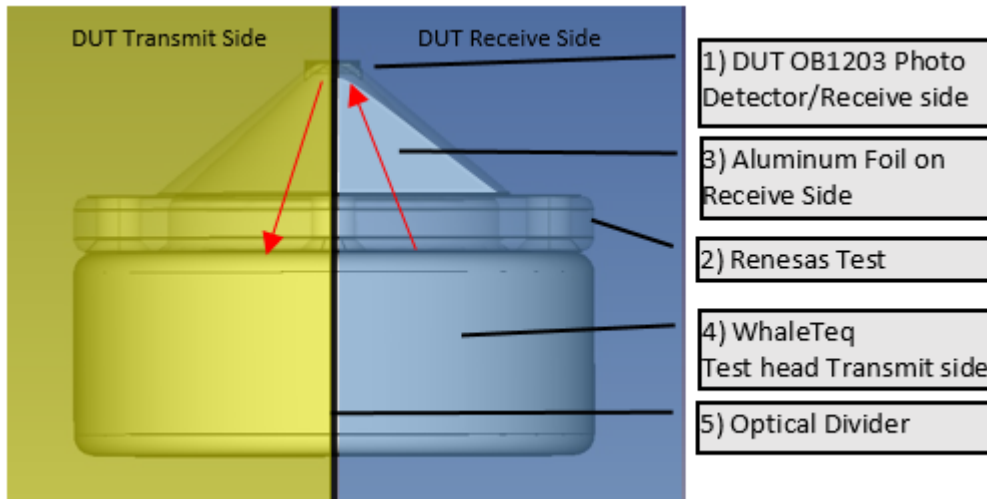

Figure 9. Test Stack Up with Aluminum Foil Insert on the Receive Side of the DUT

2. Renesas Test Adapter.

The DUT must be aligned optically so that the light is un-obstructed in both directions. Pay special attention to the alignment of the optical divider inside the cone because it must be in the correct orientation separating the light between LEDs and Photo detectors with minimal crosstalk.

3. The Renesas test adapter should have at least one side of the cone covered with a reflective material such as a layer of Aluminum foil. Please use the provided applicator and follow the instructions on inserting the reflective layer into the cone. **The reflective side of the cone should be on the sensor side of the DUT.**
4. WhaleTeq Test Head.

The test head also has an optical divider eliminating crosstalk between the LED and photo detector. Please ensure that the all dividers are aligned properly.

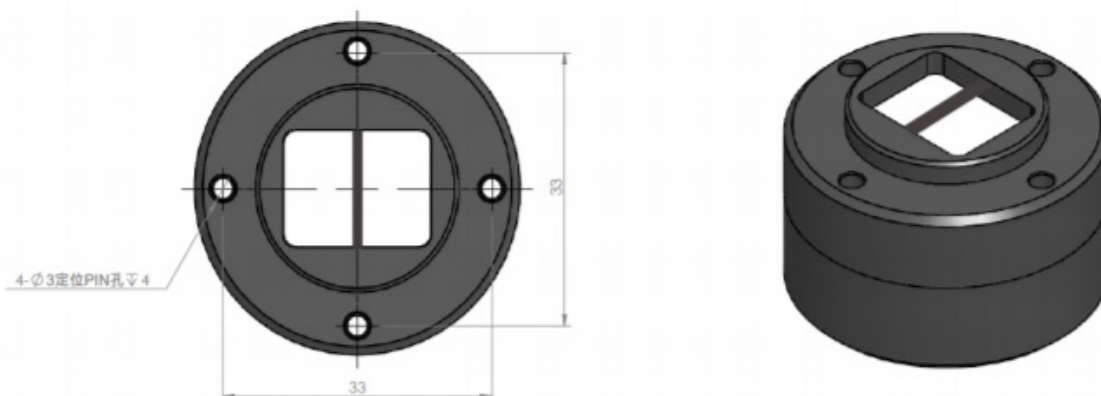



Figure 10. WhaleTeq Test Head with Optical Divider

4. Reference Board Setup and Preparation

To simplify this step, it is recommended to use an OB1203SD-RL-EVK board from Renesas. Please contact Renesas support to request.

Each OB1203SD-RL-EVK is equipped with test mode software. In order to switch between “normal mode” and “test mode”, push the wake button again until “Run mode change” appears on the display. The test software supports printing test values on the display for easy post-processing.

This OB1203 test software is identical to the Renesas provided version running on the DUT except for the following:

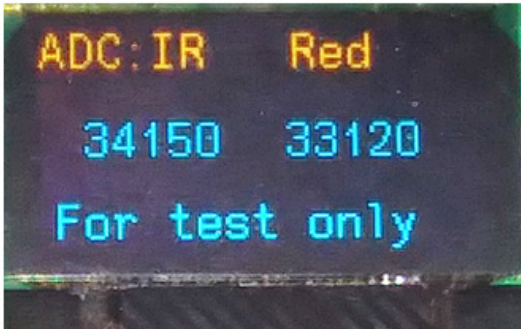
Parameter in Header File OB1203.h	SpO2 / HR Algorithm	Test Software	Comment
Light level ADC THRESH_COUNT	196 k	32 k	Required threshold of light coming from the WhaleTeq to start algorithm
PS_THRESHOLD_HI to start algorithm	15 k	200	Required threshold of light coming from the WhaleTeq to start algorithm
BIO_THRESHOLD	8 k	2 k	
Display	SpO2 / HR	<p>SpO2 / HR</p>  <p>ADC counts for IR and Red</p> 	

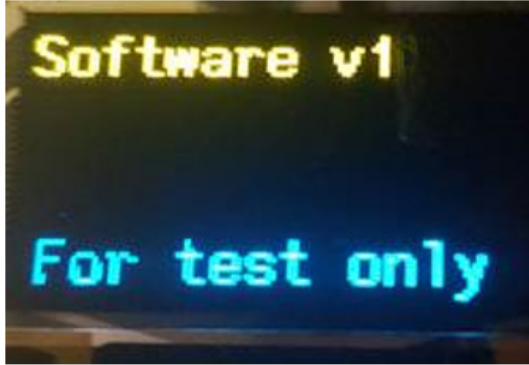
		<p>LED current</p>  <p>Software version</p> 	
MAX_LOW_SAMPLES	30	500 to allow routine to continue while changing GUI parameters for 10 s	Keeps the algorithm awake preventing battery conserving time out
SpO2 display	70 to 100%	45 to 110%	Range limit in Display

In order to re-flash the DUT

1. Download the Renesas [Flash Programmer](#).
2. Create a new project as described in the *Renesas Flash Programmer Manual* (please see the manual on the [Flash Programmer](#) webpage) which is downloaded with the Flash Programmer software.
3. In the Programmer setup, use as controller the RL78 group, R5F100BG as device, and the .mot file as the programming file.
 - a. Buy a Flash Programmer like the [Renesas E2 lite](#).

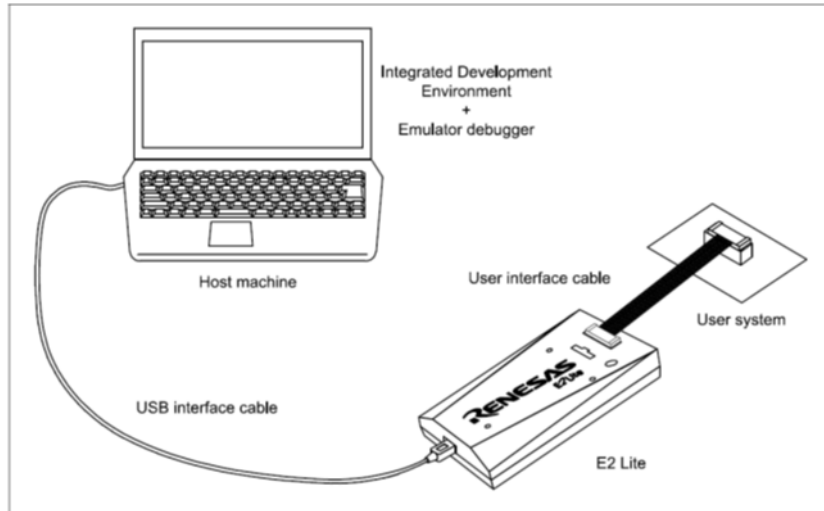

b. Set up as described in the manual.

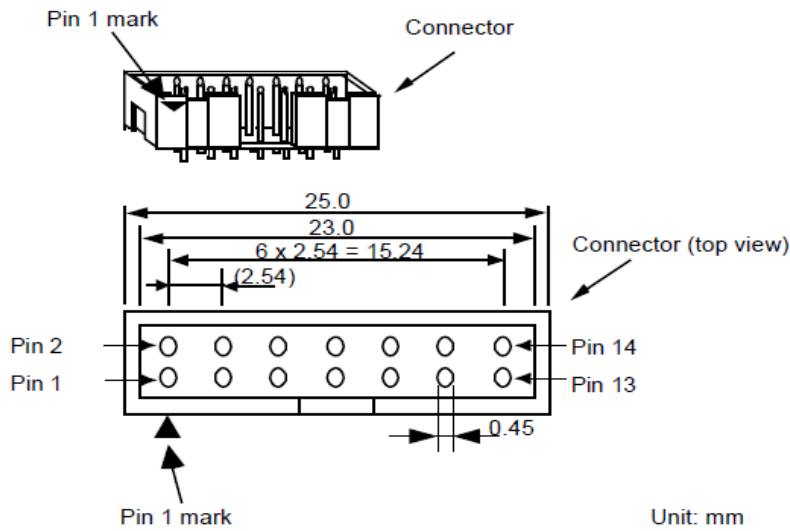

Table 1. Required Pins

Function	Pinout at Programming Tool
Ground	Pin 2, 12 and 14 (connect all)
Vcc	Pin 8
Reset	Pin 10 and 13 (connect both)
Tool0	Pin 5

- c. Connect the Flash programmer to the adapter board and the adapter board to the four pin E1 connector on the RL78 evaluation board. The pinout of the connector is listed on the evaluation board. The pins are:
 - Vcc (3.3 VDC)
 - Tool0
 - Reset
 - Ground



- d. Flash the *.mot file on the RL78

5. Test Setup Calibration using the Reference Board

Run the calibration software on the OB1203SD-RL-EVK Reference board. It scrolls through four screens that illustrate calibration values necessary for this process.

SpO2 / HR



ADC counts for IR and Red

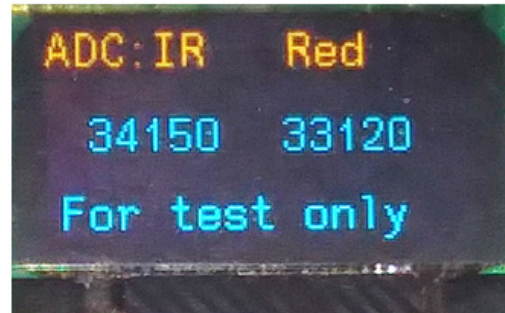

LED current



Software version

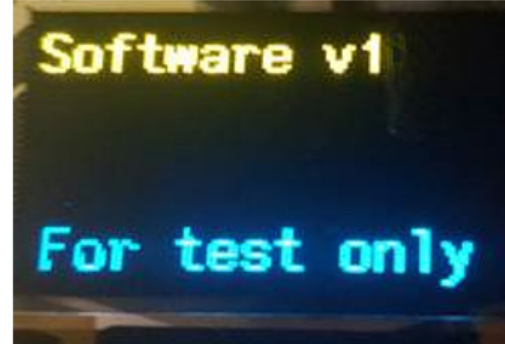

Figure 11. Calibration Software Screens

5.1 Initial Setup of the AECG100 Tester

5.1.1. Calibration of Opto-mechanical Test Fixture

This test calibrates the optical parameters of the test fixture and ensures that the DUT receives sufficient signal to continue with this test. To assure a consistent reference, this step is performed with the OB1203SD-RL-EVK reference board as described in the previous steps.

5.1.1.1. WhaleTeq AECG100 Setup

1. Set the AECG100 SpO2 settings to the following parameters in the GUI.

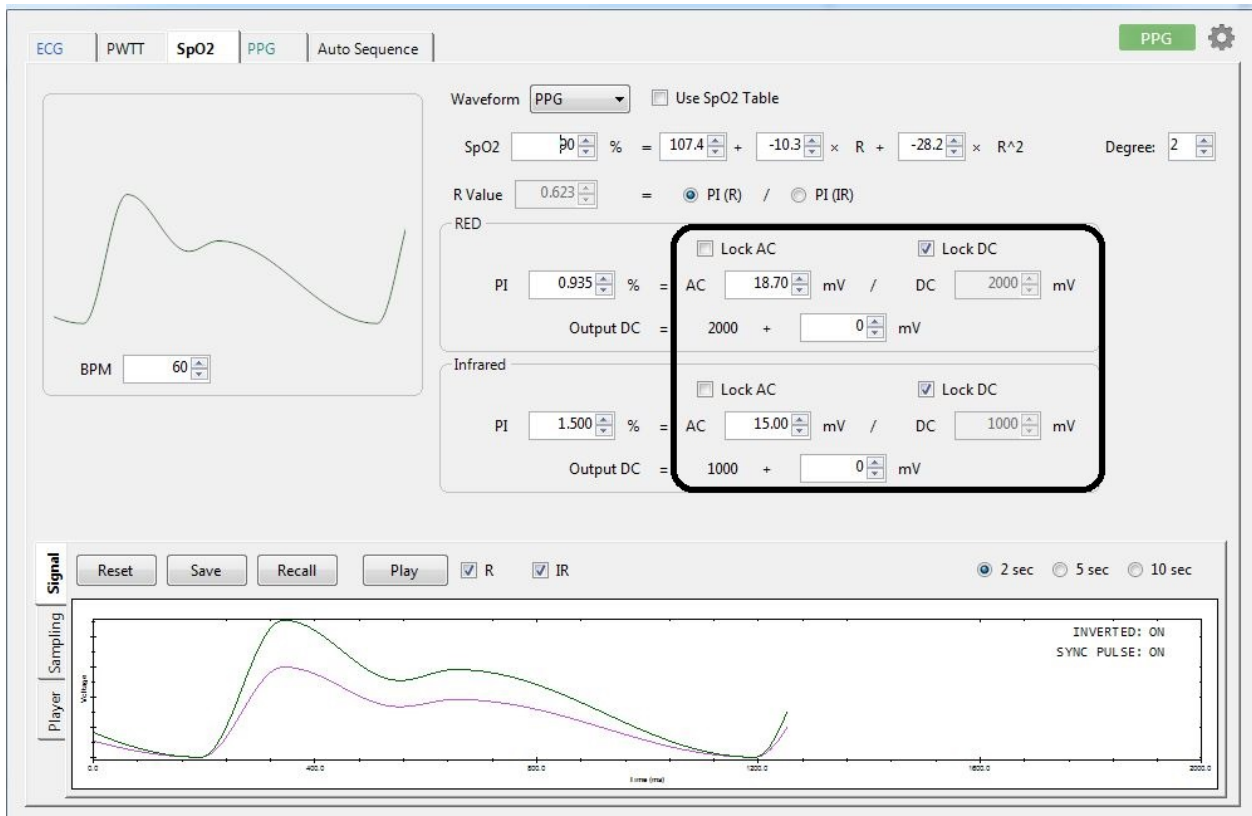

Figure 12. WhaleTeq AECG100 GUI Screenshot for Initial Test Fixture Setup

- In the SpO2 Tab:
 - In the RED Parameter block:
 - Check Lock DC box
 - Red AC of 18.70 mV
 - Red DC of 2000 mV
 - In the IR Parameter block:
 - Check Lock DC box
 - IR AC of 15.00 mV
 - IR DC of 1000 mV

For this test, all other settings can be left to default.

2. Push “Play” and observe the IR and Red ADC counts on the calibration reference devices’ OLED display running the OB1203 calibration software.

Adjust the IR DC and Red DC values in the WhaleTeq GUI so that the DUT Display reads 60.000 (counts) for IR and 40.000 (counts) for Red.

If the DUT screen stays in “Adjust to 50” (50 is the normalized ADC count for both, red, and IR in test mode), the WhaleTeq LED(s) is producing too much light output for the DUT to reach its nominal operating range.

In this case, reduce the IR DC and Red DC values in the WhaleTeq GUI until the DUT leaves the “Adjust to 50” screen. Then adjust the IR and Red DC values so that the DUT Display reads 60.000 for IR and 40.000 for Red.

Table 2. Test Results and Calculation of Fixture Factor

Color	Standard ADC Counts	Fixture Factor FF = Standard / Measured
IR	60.000	<calculate FFIR> FFIR = IR DC Level [mV] / 1000 mV
Red	40.000	<calculate FFRed> FFRed = Red DC Level [mV] / 2000 mV

Note: The FFIR and FFRed fixture factors should be applied to all of the AECG100 Red and IR settings moving forward in the procedure.

3. Proceed to next step.

6. DUT Determination and Correction of SpO2 Errors Induced by External Optical Crosstalk

6.1 Background

The OB1203 is designed to be used either in direct contact with skin or with a secondary cover window.

If the final DUT implementation uses an additional cover window, it may provide a path for additional optical crosstalk between the LEDs and the detector. Because this cross-coupled light can induce SpO2 measurement errors, Renesas recommends that it to be determined and compensated for. The following procedure describes how to determine the amount of crosstalk and how it can be eliminated at the DUT system level.

6.2 Methods

1. Simulator testing is used to predict the impact of a secondary cover window on the SpO2 performance of the DUT.
2. A software correction factor is developed to compensate for crosstalk effects of the cover window.
3. The effectiveness of the correction factor is verified on the simulator.

The following figure shows the various light paths possible between the emitters and detector on a typical reflectance oximeter.

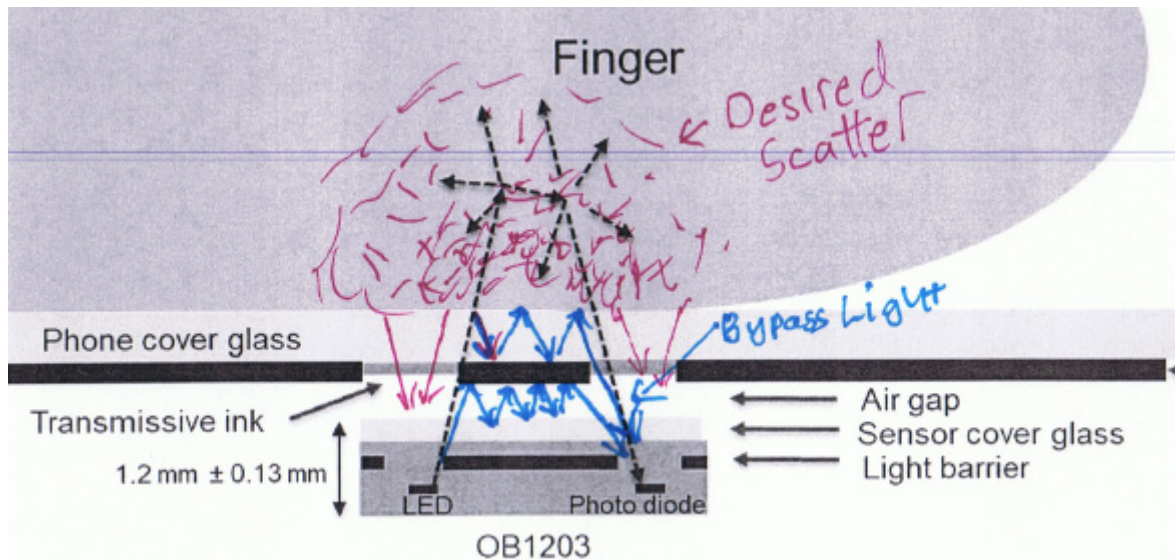

Estimate the impact of the cover window of the DUT:

1. Remove the cover window from the DUT and apply it to the reference board prepared in the previous section.
2. Apply black carbon tape on top of the cover window.
3. Start the DUT and let the ADC readout stabilize. In order to achieve better resolution, the LED current automatically increases to a preset or until the crosstalk reaches 7000 ADC counts. Read the IR and red AC counts (average the numbers displayed) and the LED currents in mA. Add the values in the following table.
4. To verify the influence of the black tape, repeat the measurement without cover window on the DUT by applying the black tape directly onto the OB1203.

Black tape applied directly to OB1203:	Note ADC counts per mA red	Note ADC counts per mA IR
Black tape applied to cover window	Note ADC counts per mA red	Note ADC counts per mA IR

Next, enter the ADC and mA values of the DUT with cover glass in the header file **OB1203.h**, as `cross_ir_adc`, `cross_ir_mA`, `cross_r_adc`, `cross_r_mA`. In the following example, the IR current was 170mA and the IR ADC count 600. Compile and load the program.

```
#define cross_ir_adc 600
#define cross_ir_mA 170

#define cross_r_adc 400
#define cross_r_mA 127
```

This sets the crosstalk cancellation in the software.

If you want to repeat the procedure, set the `cross_r_mA` and `cross_ir_mA` value to zero.

When the crosstalk cancellation is set by following the above process, the ADC values become small and comparable to the noise that causes some changes in the ADC counts.

6.3 Crosstalk Correction Validation

A Whaleteq AECG100 simulator was used to validate SpO2 measurement performance.

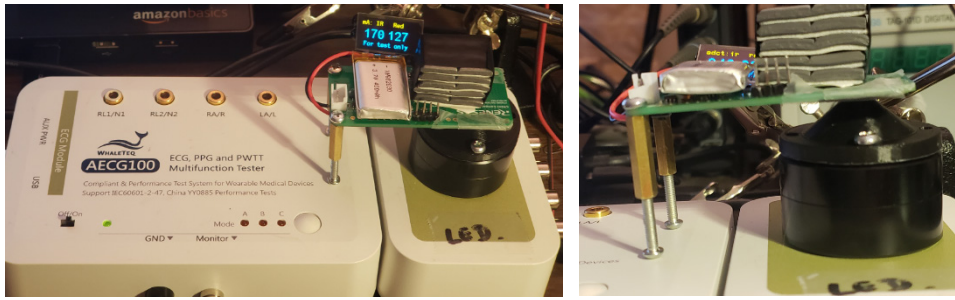

The following graph shows that the cover window induces significant inaccuracy while the cross-coupling correction factor corrected the measurement.

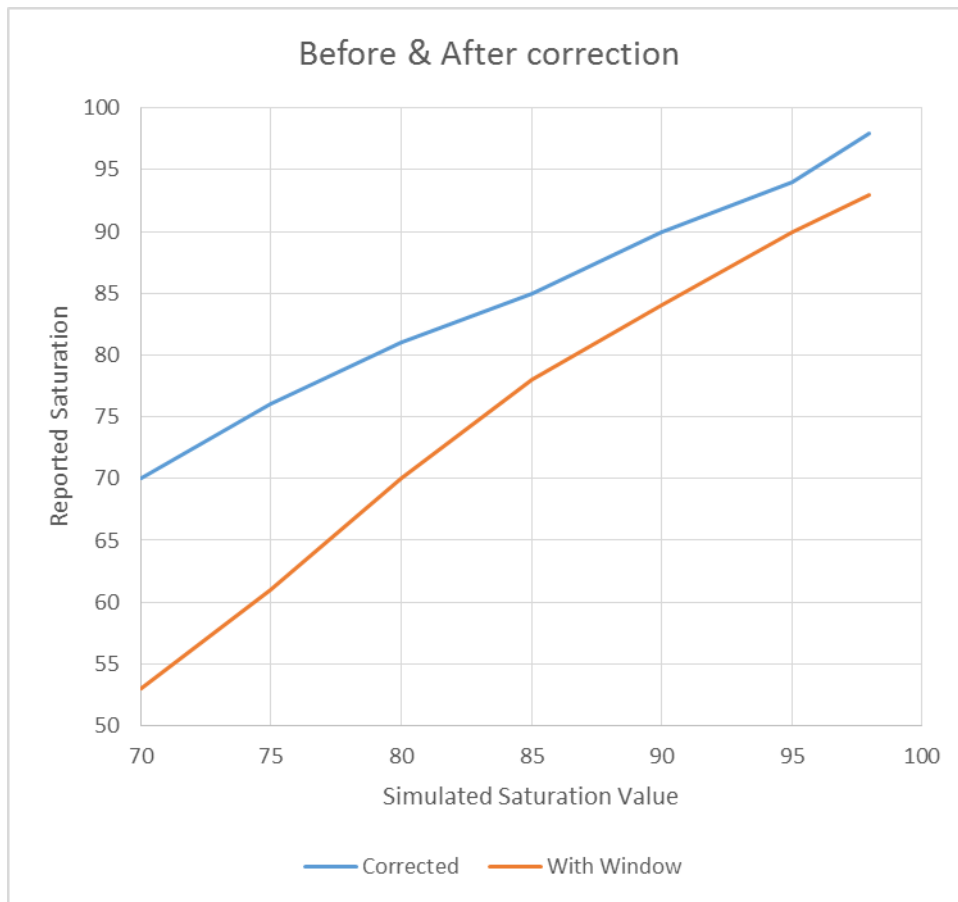

Figure 13. Before and After Correction

The results in the graph show that while cross-coupling through a cover window can have a large effect on accuracy, the OB1203 software can successfully correct for any particular cover window inducing cross-coupling.

7. DUT – Dark Skin Sensitivity and Low Perfusion Limit Determination

7.1 Dark Skin Sensitivity Test

This procedure tests the performance of the DUT at the “corner” of dark skin sensitivity and low perfusion. It represents the worst-case condition in a human subject test case ensuring that the DUT is likely to perform to the required certification standard levels.

Complete the following instructions:

1. Run the test mode on the DUT.
2. Set up the DUT on the WhaleTeq AECG100 test fixture using the adapter used in the reference calibration step before. It is likely that you have to make some opto-mechanical adjustments – this is acceptable and within reasonable limits.
3. Set the following AECG100 settings in the GUI.

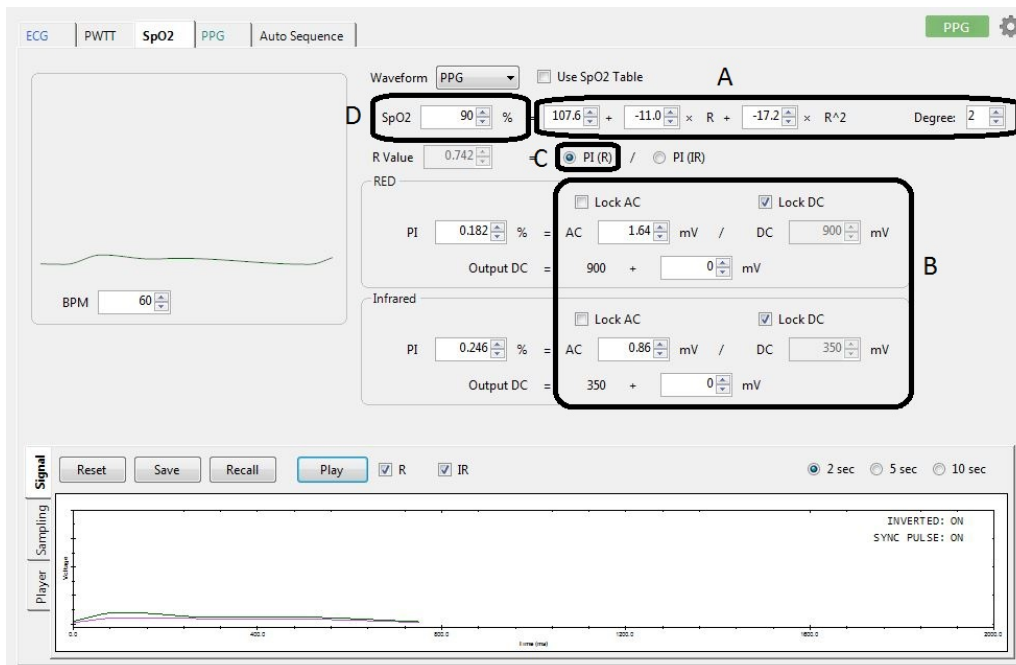

- a. Set the default calibration curve of the DUT’s OB1203 algorithm. These are the values wanted to evaluate and adjust using this procedure.

$$\text{SpO2} = 107.36 - 10.29 * R - 28.15 * R^2$$
- b. Set the AC and DC settings per line 1 of Table 3. Check the “lock DC” boxes for both red and IR.
- c. Click the radio button for PI(R).
- d. Set the SpO2 value to 90%. This will automatically adjust the Red AC to simulate 90%.

Table 3. Adjust IR AC Counts to Find 90% SpO2 Limits for Various Skin Types

	Red DC [mV]	IR DC [mV]	IR AC [mV] ^[1]	GUI Red PI	GUI IR PI	GUI IR AC mV	DUT SP02 Reading	Pass/Fail 86.5% to 93.5%
Dark skin	900 ^[1] <FFRed> mV See Table 2	350 ^[1] <FFIR> mV See Table 2	0.86 ^[1] <FFIR> mV					
Darker skin	450 ^[1] <FFRed> mV See Table 2	175 ^[1] <FFIR> mV See Table 2	1.7 ^[1] <FFIR> mV					
Darkest skin	225 ^[1] <FFRed> mV See Table 2	100 ^[1] <FFIR> mV See Table 2	3.5 ^[1] <FFIR> mV					

1. Adjust IR AC to the minimum necessary to get a correct DUT SP02 Reading of 90%

4. Push Play and observe the SpO2 value on the DUT OLED display.
5. Increase the setting of the IR AC in small steps until the level is found where the value is within 3.5% of the set value of 90%. Record the PI AND AC values in the IR box necessary to achieve a 90% SpO2 value. If the PI is too low the reading can either be incorrect or not shown in the display. It is necessary that the DUT does not display an incorrect value; therefore, the threshold must be determined and added to the software. Note that the perfusion index can be increased by warming your finger.
6. Repeat this test for lines 2 and 3 of the table.

7.2 Determination of the Minimum Signal Strength Threshold

To calculate the threshold values for IR and Red, do the following:

1. Red AC Threshold ADC count = Red DC ADC count (from the DUT display) * PI (Red)
2. IR AC Threshold ADC count = IR DC ADC count (from the DUT display) * PI (IR)

7.3 SP02 Saturation Value Test before Calibration

This procedure tests whether the DUT is properly reporting values from 100% to 70%. This will establish the correction values (R-curve) for the DUT on the simulated test. It does not check the actual accuracy on human test subjects.

Set the AECG100:

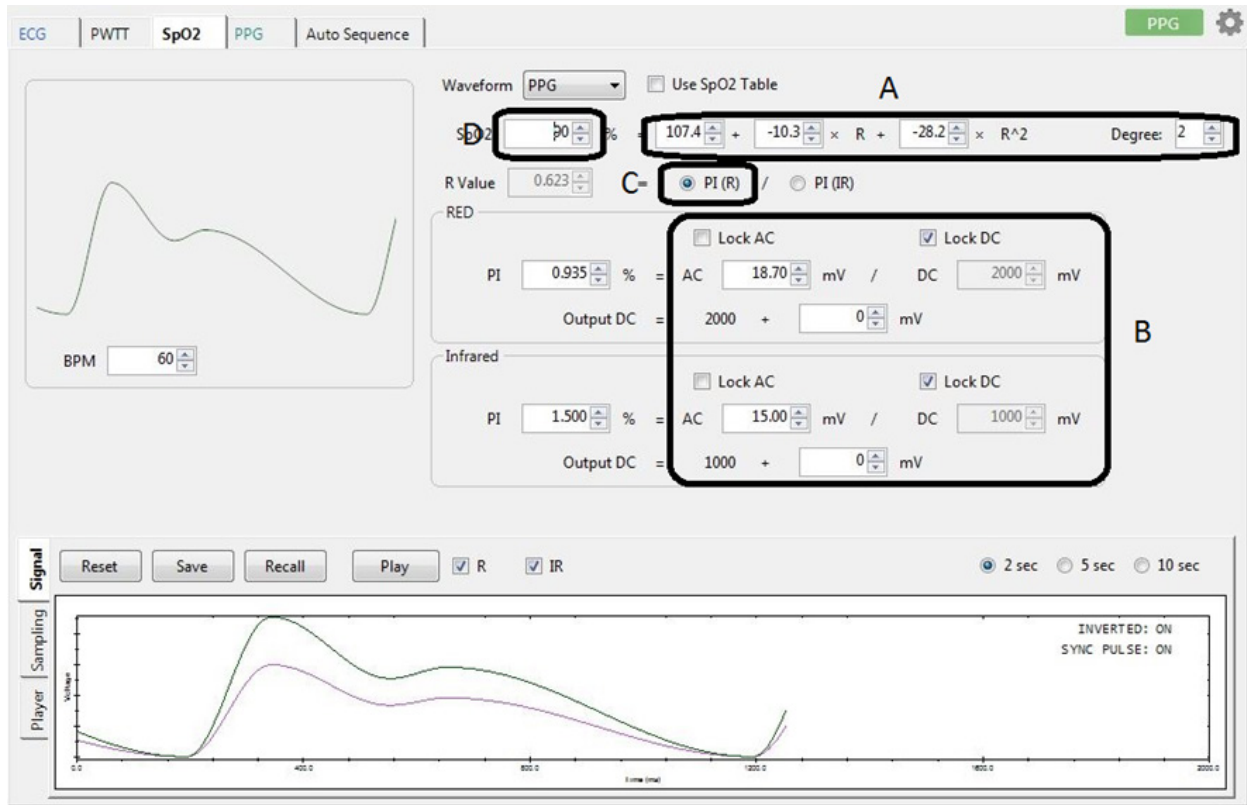

- a. Set the default calibration curve of the OB1203.

$$\text{SpO}_2 = 107.36 - 10.29 * R - 28.15 * R^2$$
 (default calibration curve)
- b. Set the AECG100 SpO2 settings to:
 - o Red DC of 2000mV
 - o IR DC of 1000mV
 - o Click both Lock DC boxes
 - o Red AC of 15mV
 - o IR AC of 18.7mV
- c. Click the radio button for PI(R).

- d. Adjust the R-curve: Set the SpO2 value to each of the values in the Excel spreadsheet (see the following figure and *Recalculation of R-curve* XLS located on the [OB1203SD-RL-EVK](#) webpage). This will automatically adjust the Red AC to simulate the set value in the GUI.

1 Default starting point								
Default R-curve as set in the GUI		SpO2 (DUT) used =	-28.149 R ² +	-10.293 R +	107.36			
2 Run the test procedure - enter measured SpO2 values in the yellow field								
Obtain the new DUT R-curve				Preset	Measured	Calculated		
		SpO2 WhaleTeq	SpO2 DUT		R DUT			
		100	98		0.42210		Measured SpO2 values	
		95	94		0.52994			
		90	87		0.68707			
		85	83		0.76523			
		80	78		0.85469			
		75	74		0.92105			
		68	65		1.057442			
3 Use new R-Curve values before running the validation test								
Type in the reference and measured SpO2 values		SpO2 (DUT) new =	-25.326 R ² +	-13.432 R +	110.01		New R-Curve Values	

Document the readings in the Excel spreadsheet.

The R-curve is a second degree function of the R value. It uses three coefficients, a factor for R², one for R, and a constant. The default coefficients in the software are listed at the top of the spreadsheet: -28.149 is the factor for R², -10.293 for R, and 107.36 is the constant. The numbers for corrected R-curve are shown in green.

Adjustment of the R-curve in the software: Write the new numbers in **SpO2.h** as shown below; re-compile the program, and re-load it on the MCU.

```
// R - curve: SpO2 = Rsquare * R * R + Rlinear * R + Rconstant
#define Rsquare    -28.149    // coefficient for R square
#define Rlinear    -10.293    // coefficient for R
#define Rconstant  107.36    // constant
```

7.4 SpO2 Saturation Validation

Repeat the measurements as shown in the Excel spreadsheet’s validation step to validate that the DUT is now measuring correctly.

7.5 Test Report Generation

With the values from the validation step, the “Report” tap generates a test report.

8. Human Calibration Test

This test is performed in an outside test lab. For calibration, typically five subjects are tested. Based on passing the previous test, we expect to get data from all five subjects. The result we get is a table for each subject of 24 paired reference and DUT readings. Note that these values are derived from 30-second periods where the SpO2 of the test subject is stabilized. This is difficult to do so the exact reference values do not repeat subject to subject. The result is a “cloud” of data over all of the readings of the reference device and the DUT.

9. Revision History

Revision	Date	Description
1.0	Mar 11, 2021	Initial release.

IMPORTANT NOTICE AND DISCLAIMER

RENESAS ELECTRONICS CORPORATION AND ITS SUBSIDIARIES (“RENESAS”) PROVIDES TECHNICAL SPECIFICATIONS AND RELIABILITY DATA (INCLUDING DATASHEETS), DESIGN RESOURCES (INCLUDING REFERENCE DESIGNS), APPLICATION OR OTHER DESIGN ADVICE, WEB TOOLS, SAFETY INFORMATION, AND OTHER RESOURCES “AS IS” AND WITH ALL FAULTS, AND DISCLAIMS ALL WARRANTIES, EXPRESS OR IMPLIED, INCLUDING, WITHOUT LIMITATION, ANY IMPLIED WARRANTIES OF MERCHANTABILITY, FITNESS FOR A PARTICULAR PURPOSE, OR NON-INFRINGEMENT OF THIRD-PARTY INTELLECTUAL PROPERTY RIGHTS.

These resources are intended for developers who are designing with Renesas products. You are solely responsible for (1) selecting the appropriate products for your application, (2) designing, validating, and testing your application, and (3) ensuring your application meets applicable standards, and any other safety, security, or other requirements. These resources are subject to change without notice. Renesas grants you permission to use these resources only to develop an application that uses Renesas products. Other reproduction or use of these resources is strictly prohibited. No license is granted to any other Renesas intellectual property or to any third-party intellectual property. Renesas disclaims responsibility for, and you will fully indemnify Renesas and its representatives against, any claims, damages, costs, losses, or liabilities arising from your use of these resources. Renesas' products are provided only subject to Renesas' Terms and Conditions of Sale or other applicable terms agreed to in writing. No use of any Renesas resources expands or otherwise alters any applicable warranties or warranty disclaimers for these products.

(Disclaimer Rev.1.01)

Corporate Headquarters

TOYOSU FORESIA, 3-2-24 Toyosu,
Koto-ku, Tokyo 135-0061, Japan
www.renesas.com

Trademarks

Renesas and the Renesas logo are trademarks of Renesas Electronics Corporation. All trademarks and registered trademarks are the property of their respective owners.

Contact Information

For further information on a product, technology, the most up-to-date version of a document, or your nearest sales office, please visit www.renesas.com/contact-us/.