

**Bat Detector – Ultrasound Translator**  
**SLG46537**

The application note gives step-by-step guidelines for creating a bat detector – ultrasound translator with a 2N2222A and BC558 transistors.

The application note comes complete with design files which can be found in the Reference section.

**Contents**

**1. Terms and Definitions ..... 2**

**2. References ..... 2**

**3. Introduction ..... 3**

**4. Introducing the Bat Detector ..... 3**

**5. GreenPAK Design ..... 3**

    5.1 Frequency Step Down ..... 4

    5.2 Base Half Pulse ..... 4

    5.3 Width modulation ..... 6

    5.4 Final Outcome ..... 13

    5.5 Output Stage..... 15

**6. Conclusion ..... 15**

**7. Revision History ..... 16**

**Figures**

Figure 1. Block Diagram .....3

Figure 2. CNT0/DLY0 configuration .....4

Figure 3. CNT1/DLY1 configuration .....5

Figure 4. Full application.....5

Figure 5. Ultrasonic signal vs. Stepped down Frequency .....6

Figure 6. Ultrasonic signal vs. Stepped down + delay 1.....6

Figure 7. Average volume level .....7

Figure 8. A CMP network.....7

Figure 9. A CMP0 Configuration.....8

Figure 10. A CMP-CNT/DLY network.....8

Figure 11. Time-table of all Delay devices .....9

Figure 12. Delay devices-NOR network .....9

Figure 13. Pin6 (CH2)<300mV Delay =none (CH1) .....10

Figure 14. Pin6>300 mV(CH2) Dly =0.050 ms (CH1) .....10

Figure 15. Pin6>600 mV(CH2) Dly=0.100ms (CH1) .....11

Figure 16. Pin6>900 mV (CH2) Dly=0.150 ms (CH1) .....11

Figure 17. Pin6>1200 mV (CH2) Dly=0.200 ms (CH1) .....12

Figure 18. CNT5/DLY5 Configuration.....	12
Figure 19. Ultrasonic detection.....	13
Figure 20. Ultrasonic signal in Piezo applied to Pin6, Output on Pin4 (0.050ms).....	13
Figure 21. Ultrasonic signal in Piezo applied to Pin6, Output on Pin4 (0.100ms).....	14
Figure 22. Ultrasonic signal in Piezo applied to Pin6, Output on Pin4 (0.150ms).....	14
Figure 23. Ultrasonic signal in Piezo applied to Pin6, Output on Pin4 (0.200ms).....	15
Figure 24. Speaker driver .....	15

## 1. Terms and Definitions

CMP	Comparator
CNT	Counter
DLY	Delay
PWM	Pulse Width Modulation
TTL	Transistor-Transistor Logic

## 2. References

For related documents and software, please visit:

[GreenPAK Programmable Mixed-Signal Products | Renesas](#)

Download our free Go Configure Software Hub [1] to open the .gp files [2] and view the proposed circuit design. Use the GreenPAK development tools [3] to freeze the design into your own customized IC in a matter of minutes. Renesas provides a complete library of application notes [4] featuring design examples as well as explanations of features and blocks within the Renesas IC.

[1] [Go Configure Software Hub](#), Software Download and User Guide, Renesas Electronics

[2] [AN-1142 Bat Detector – Ultrasound Translator.gp](#), GreenPAK Design File, Renesas Electronics

[3] [GreenPAK Development Tools](#), GreenPAK Development Tools Webpage, Renesas Electronics

[4] [Application Notes](#), GreenPAK Application Notes Webpage, Renesas Electronics

[5] [SLG46537 Datasheet](#), Renesas Electronics

### 3. Introduction

In many cultures, bats are perceived as bad omens, as symbols of death or as manifestations of bloodsucking vampires. This may have arisen from the fact that a few species (eg. vampire bats) feed from cattle and can carry biological agents. However, in reality, bats are helpful creatures that play an important role in pollination, spreading seeds, and in providing a natural pest management service.

<https://www.bats.org.uk/about-bats/bat-detectors-1>

<https://www.bats.org.uk/about-bats/why-bats-matter>

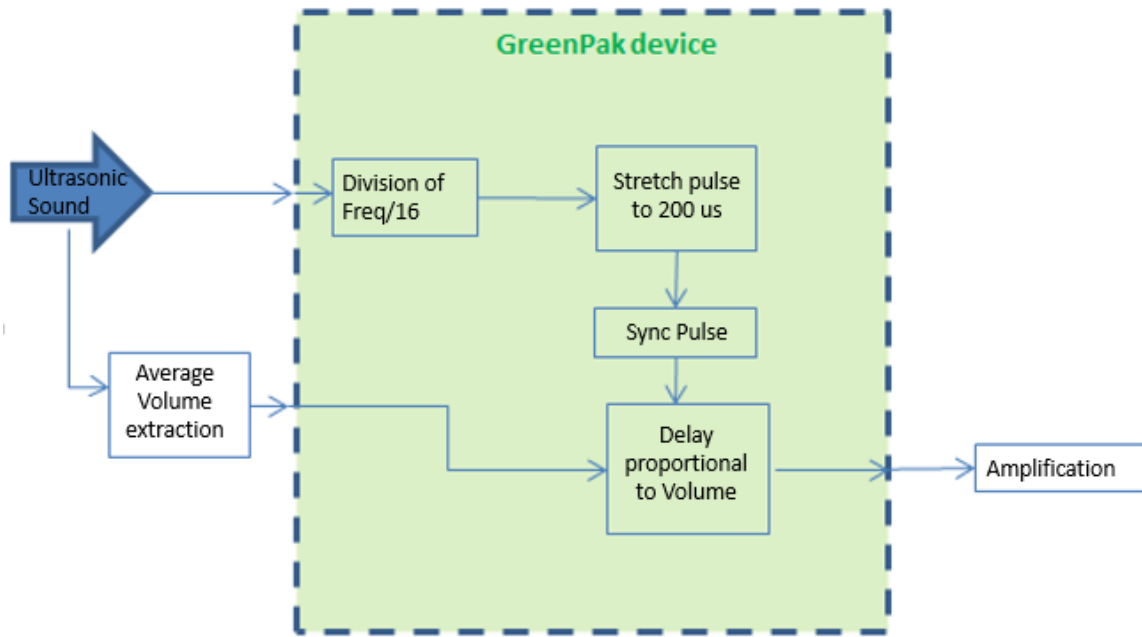

Figure 1. Block Diagram

### 4. Introducing the Bat Detector

A Bat Detector can notify us about the presence of bats, along with assisting in the analyzing of the groups of bats, in a certain area. This application note will explain the implementation of a circuit using GreenPAK devices to process the ultrasonic signals produced by the sounds that bats emit. It will also demonstrate how these sound waves can be converted to audible frequencies using the GreenPAK’s flexible on-chip resources like counters, comparators and PWM’s.

The sensitivity of a bat’s sound can be between 0.1 kHz to 200 kHz<sup>1</sup>, but as mentioned, this note will help in stepping down the frequency by 16 or any other programmable ratio.

We will also add 4 PWMs using the available 4 Analog Comparators.

### 5. GreenPAK Design

To conceive the idea, analog comparators, counters/delay and logical gates are required. Therefore, to present this example, the device SLG46537V has been chosen.

<sup>1</sup> MacDonald, D. "Bats." *The Encyclopedia of Mammals*. New York, 1984: 792-794.  
"Bat echolocation calls: adaptation and convergent evolution"  
<https://www.ncbi.nlm.nih.gov/pmc/articles/PMC1919403/>

## 5.1 Frequency Step Down

The main core of this step is to have a counter (by the factor of 16 in this case) to divide the input frequency by. The result will be a pulse, indicating that a complete count has been reached, and afterwards we will be ready to start a new count.

Edge select:Rising. The output polarity is Non-inverted for simple analysis, Q mode reset, Stop and restart are enabled to have continuous counting. Its connections are set to the external clock from the matrix to enable counter input from pin 2. Here, the pulse output, in the presence of an ultrasonic signal, will be modulated.

## 5.2 Base Half Pulse

We use an average of 40 kHz for the ultrasonic signal just like the commercial emitter/receiver you might be able to test. We define the Period of the stepped down signal of 40 kHz/16 to 2.5kHz. The full period should be 0.4 ms with the positive cycle being 0.2 ms.

In order to form a 50% cycle duty waveform of 2.5kHz, the CNT1/DLY1 is supposed to have a base pulse of 0.1750ms 348 counts. (this complemented with the processing speed, reaches 0.200 ms)

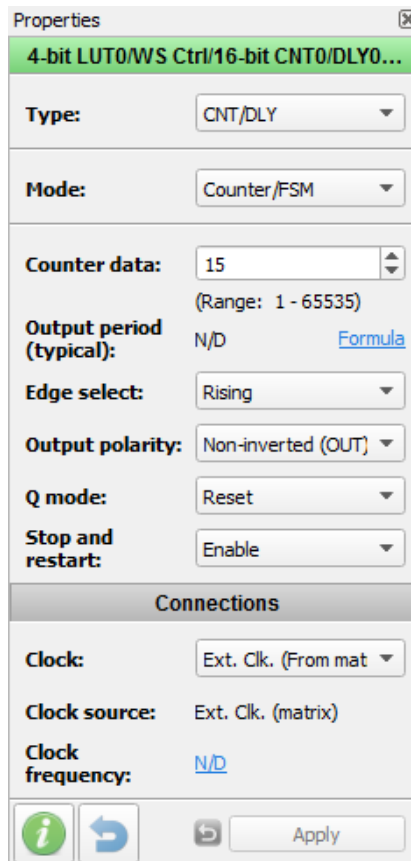

Figure 2. CNT0/DLY0 configuration

Properties ✖

**4-bit LUT1/16-bit CNT1/DLY1/FSM1**

**Type:** CNT/DLY

**Mode:** Delay

**Counter data:** 348  
(Range: 1 - 65535)

**Delay time (typical):** 174.5 us [Formula](#)

**Edge select:** Falling

**Output polarity:** Non-inverted (OUT)

**Q mode:** Reset

**Stop and restart:** Disable

---

**Connections**

**Clock:** OSC0 CLK

**Clock source:** RC OSC Freq.

**Clock frequency:** 2 MHz

Apply

Figure 3. CNT1/DLY1 configuration

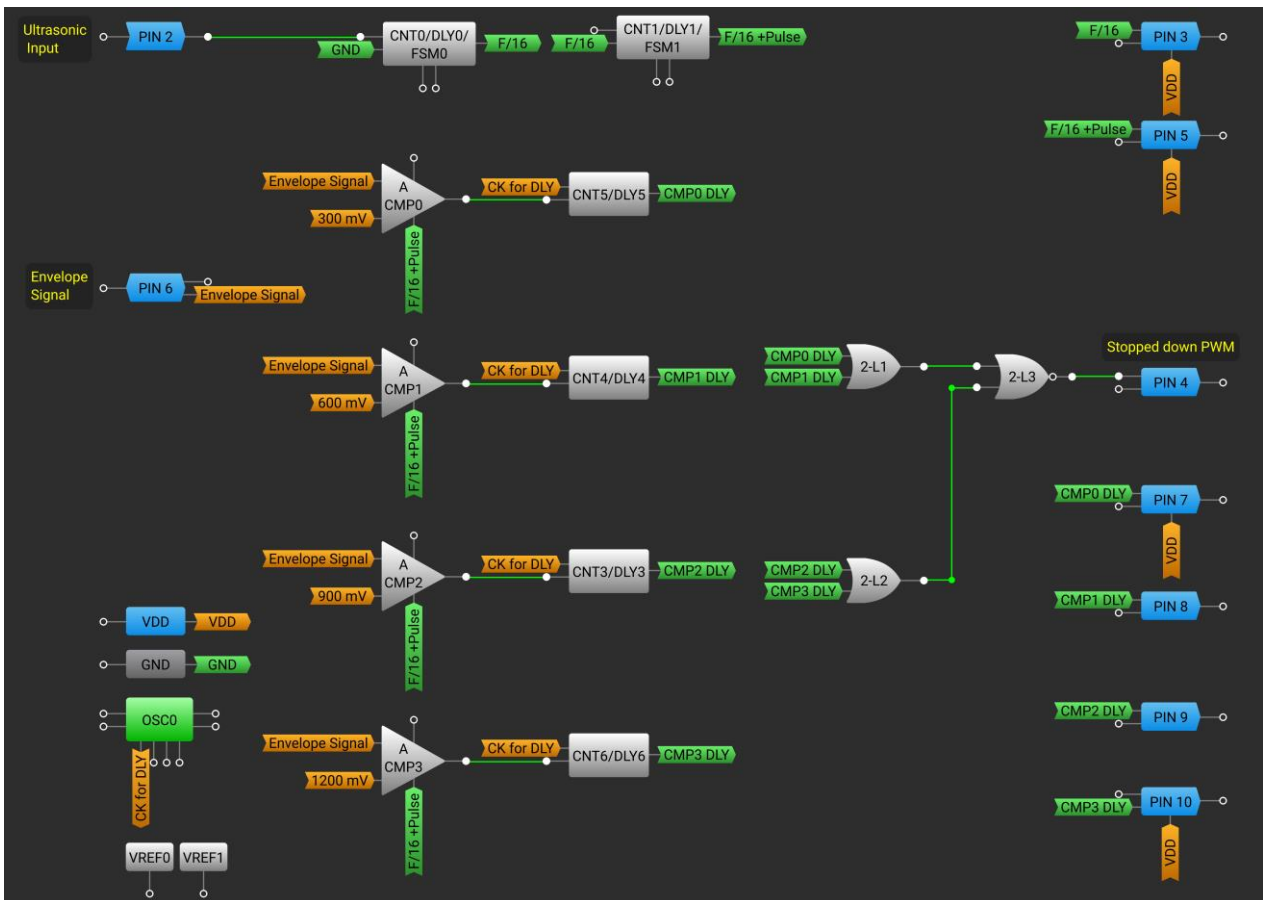

Figure 4. Full application

Figure 5 shows the input of a test frequency for the continuous 40kHz applied to PIN 2 (CH2). The result of division by 16 as output of CNT0/DLY0 =F/16 is monitored on PIN3 (CH3).

Figure 6 shows the same input frequency of 40 kHz in PIN 2 (CH2) and the output pulse of 0.200 ms from CNT1/DLY1 (CH1).

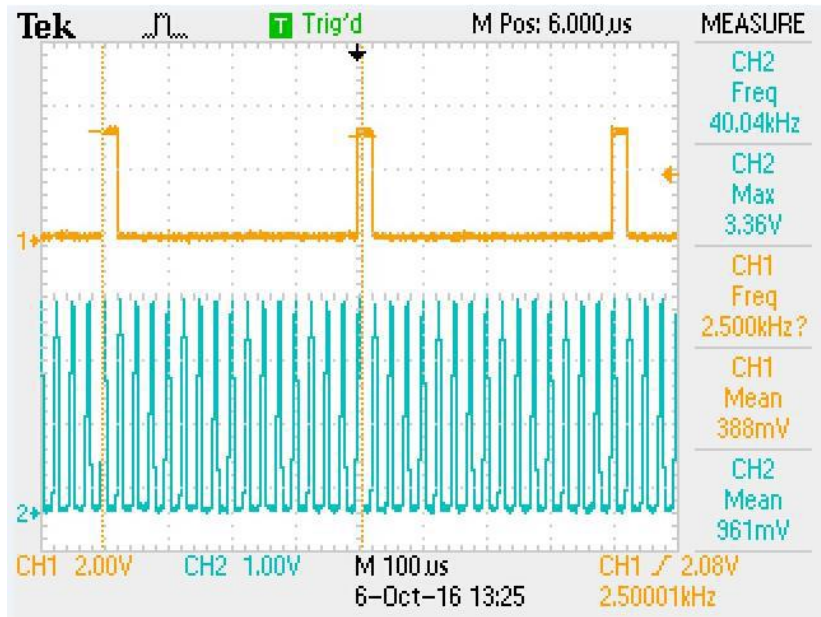

Figure 5. Ultrasonic signal vs. Stepped down Frequency

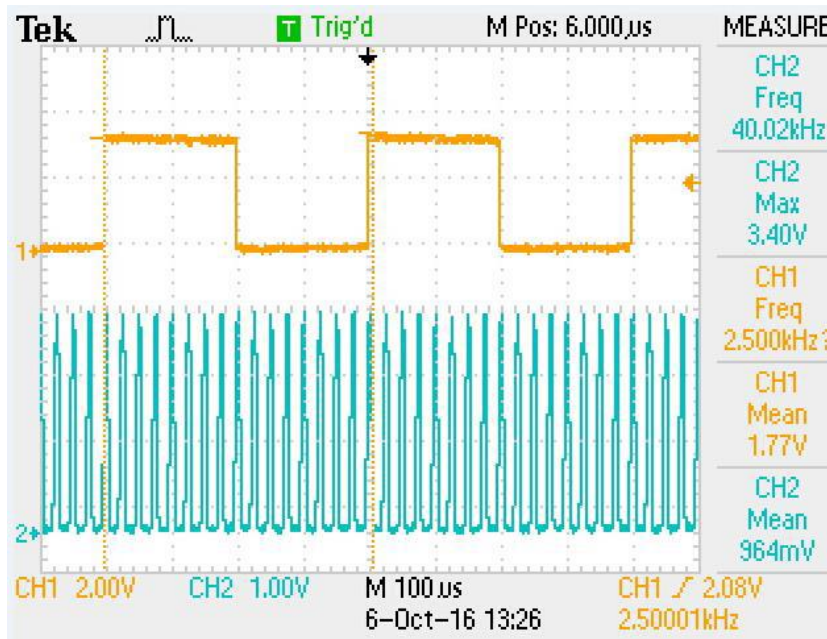

Figure 6. Ultrasonic signal vs. Stepped down + delay 1

This will become the base half pulse that will turn the analog comparators on. We will discuss this in the next segment.

### 5.3 Width modulation

The idea is to have the final output modulated in width, proportional to the input amplitude average (original soundwave volume)

In order to get this measurement, a low pass filter is implemented.

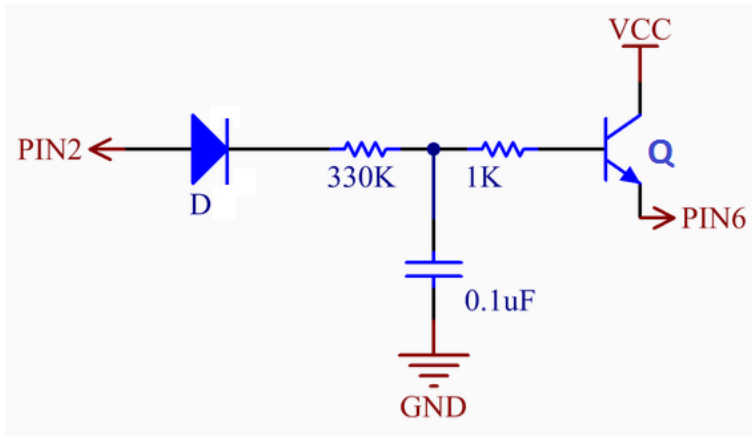

Figure 7. Average volume level

In Figure 7, the input signal is the main ultrasonic wave, and is passed through the diode D (1N4148) to avoid getting the original affected. The low pass filter is set to 5Hz to achieve sufficiently smooth averaging.

The function of Q is to buffer the analog level. Connecting the filtered signal directly to the device causes a drop on the voltage in the 0.1 uF capacitor.

The resulting level is compared in A CMP0- A CMP3.

The voltage level on PIN6 may always be present, but the comparison will start once a Pulse of 0.200ms is output from CNT1/DLY1 (F/16 + Pulse net)

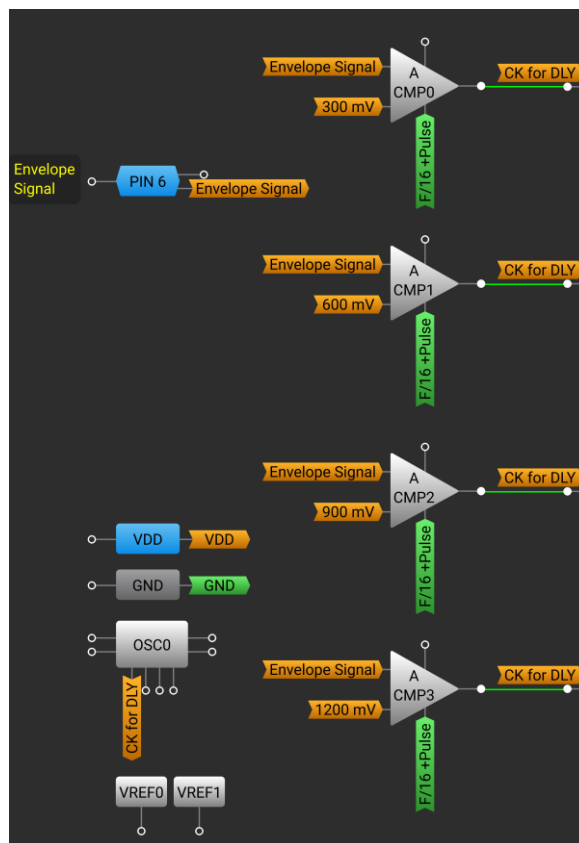

Figure 8. A CMP network

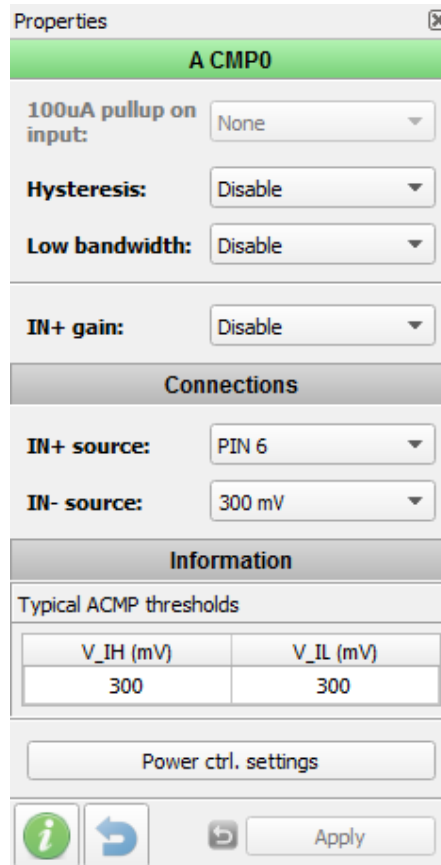

Figure 9. A CMP0 Configuration

Figure 9 shows the configuration of the A CMP0. The A CMP1-3 has a similar configuration except for the comparison level, as can be seen in Figure 8.

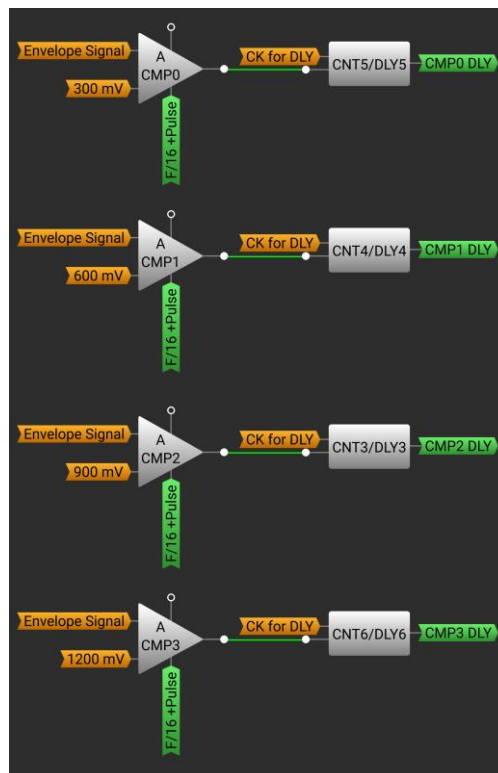

Figure 10. A CMP-CNT/DLY network

## Bat Detector – Ultrasound Translator

Each output from the A CMP0 to A CMP3 is connected to an individual CNT/DLY. Each are programmed to have a delayed output that is proportional to the level compared.

Figure 11 shows the expected delay time according to the compare level of Pin6.

That timing diagram is tested by setting an input volume, which varies in amplitude and the resulting voltage is applied to Pin 6 and the 2-L3 output gets monitored on Pin 4 (Figs. 13-18)

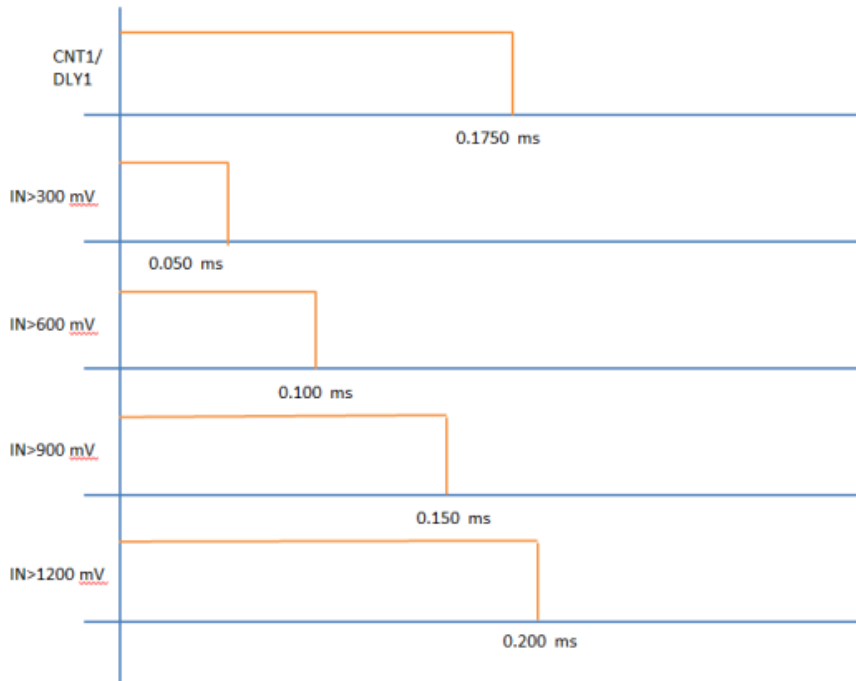

Figure 11. Time-table of all Delay devices

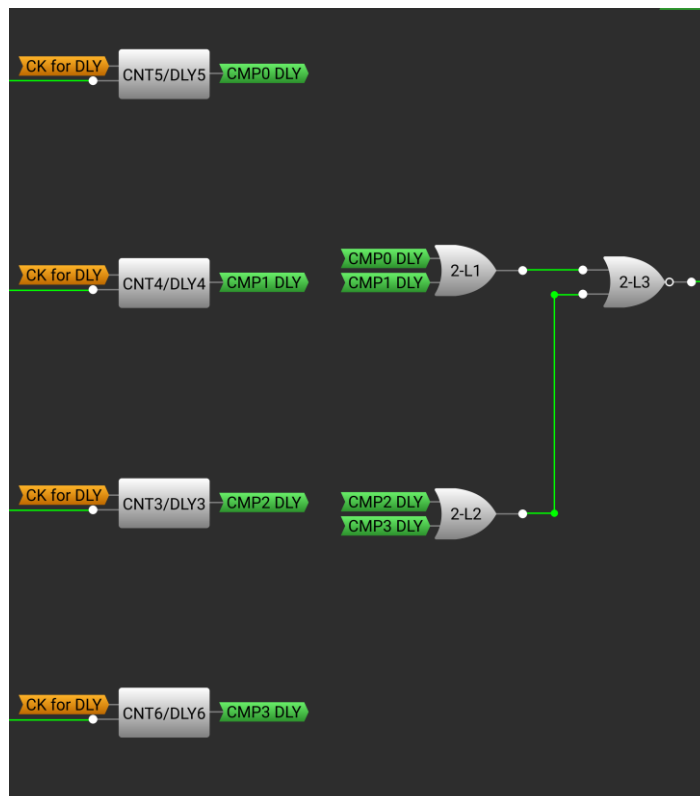

Figure 12. Delay devices-NOR network

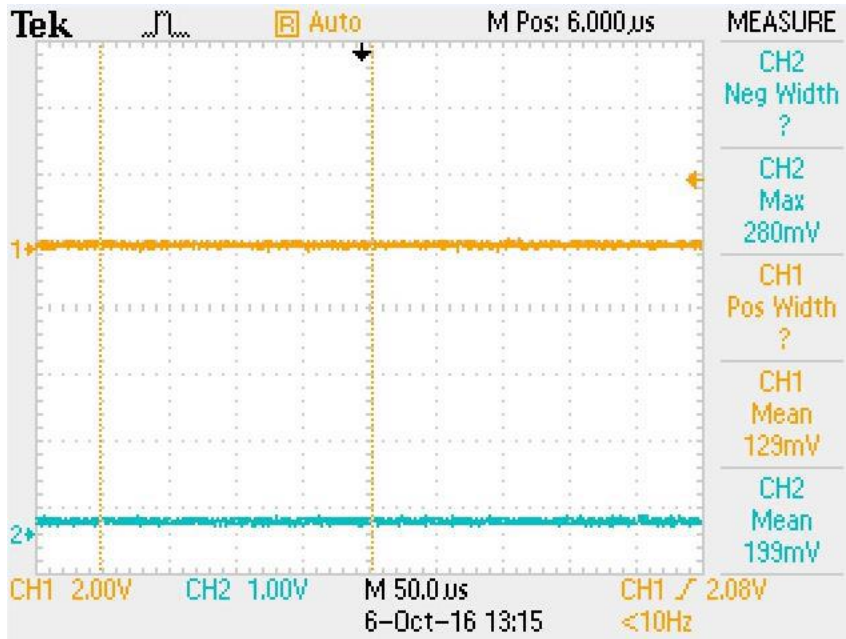

Figure 13. Pin6 (CH2)<300mV Delay =none (CH1)

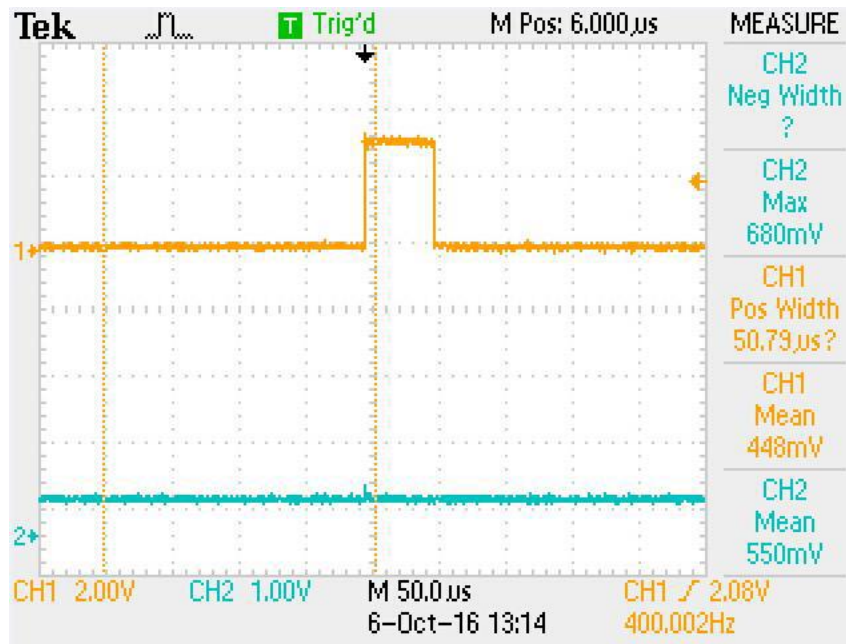

Figure 14. Pin6>300 mV(CH2) Dly =0.050 ms (CH1)

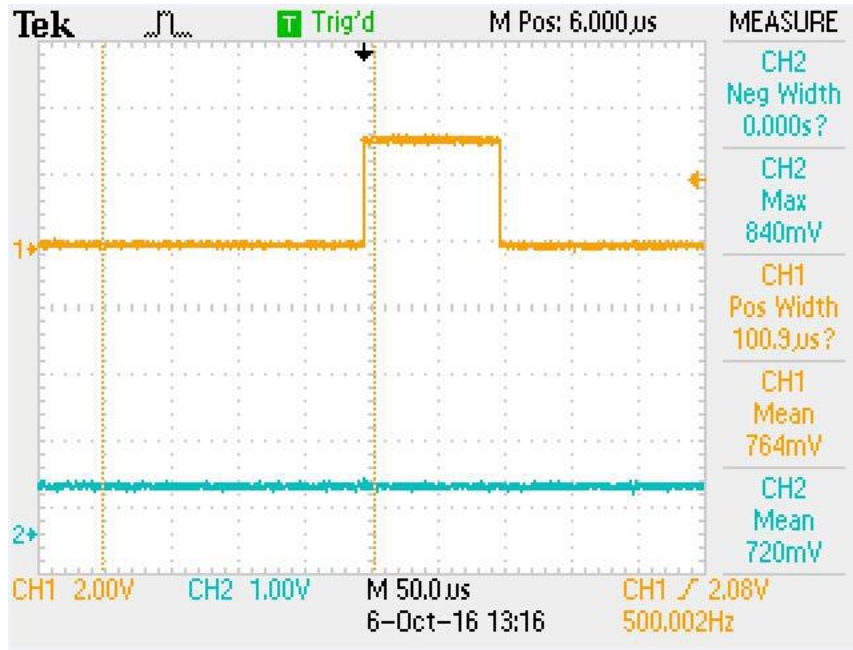

Figure 15. Pin6>600 mV(CH2) Dly=0.100ms (CH1)

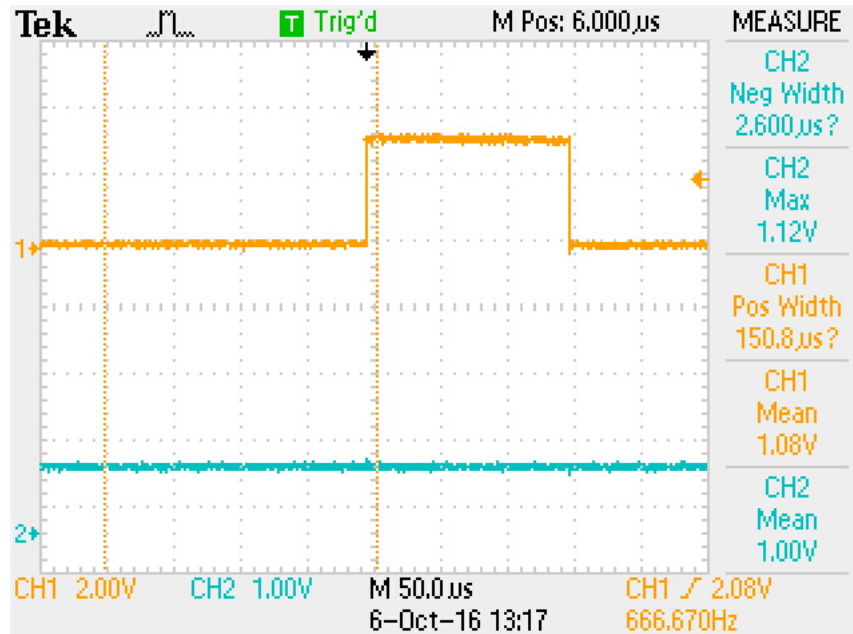

Figure 16. Pin6>900 mV (CH2) Dly=0.150 ms (CH1)

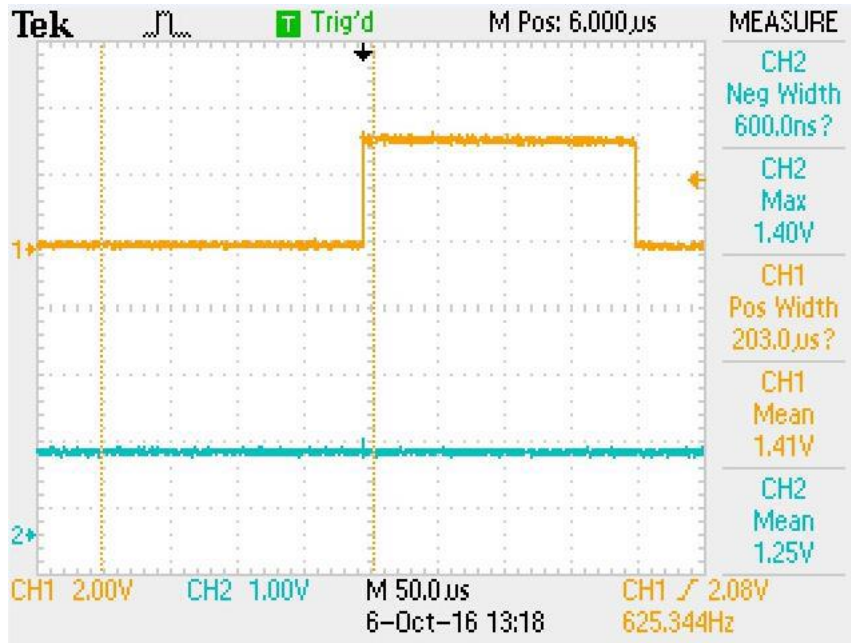

Figure 17. Pin6>1200 mV (CH2) Dly=0.200 ms (CH1)

The parameters of CNT5/DLY5 can be observed in Figure 18.

The CLK/4 is used as is suitable for our time needs having as result in each case:

- CNT5/DLY5 is set to 0.050 ms (25 counts)
- CNT4/DLY4 is set to 0.100 ms (49 counts)
- CNT3/DLY3 is set to 0.150 ms (74 counts)
- CNT6/DLY6 is set to 0.200 ms (99 counts)

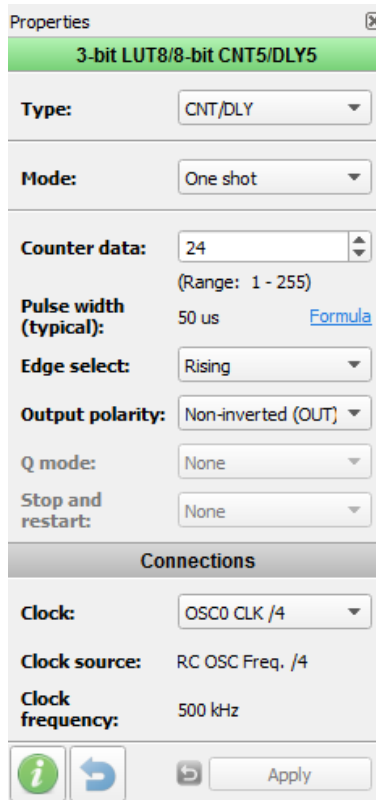

Figure 18. CNT5/DLY5 Configuration

### 5.4 Final Outcome

A modulated ultrasonic signal is applied to a piezo transducer which is close to a bat’s echolocation call.

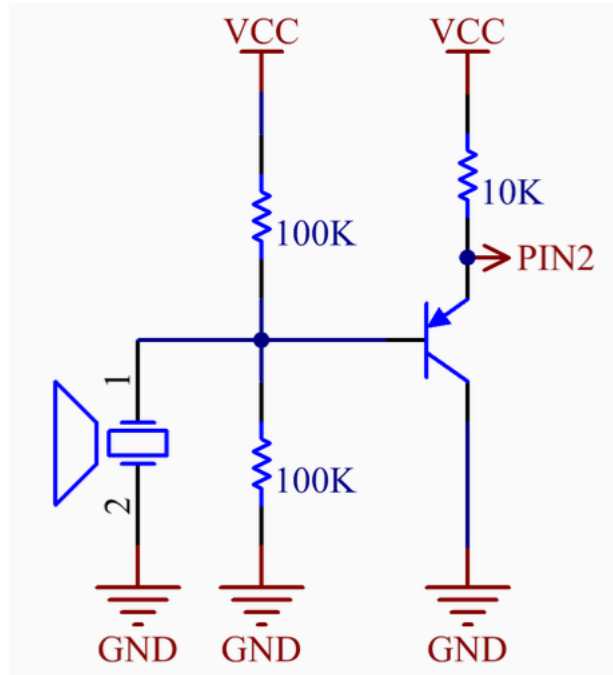

Figure 19. Ultrasonic detection

The different ultrasonic stimulus and the pulse width output can be seen on PIN 4.

It is observed that depending on the intensity of the signal, the counts are likelier to be performed. This means that the output frequency may be decreased if the main source is weak and will be more stable when the source wave is stronger.

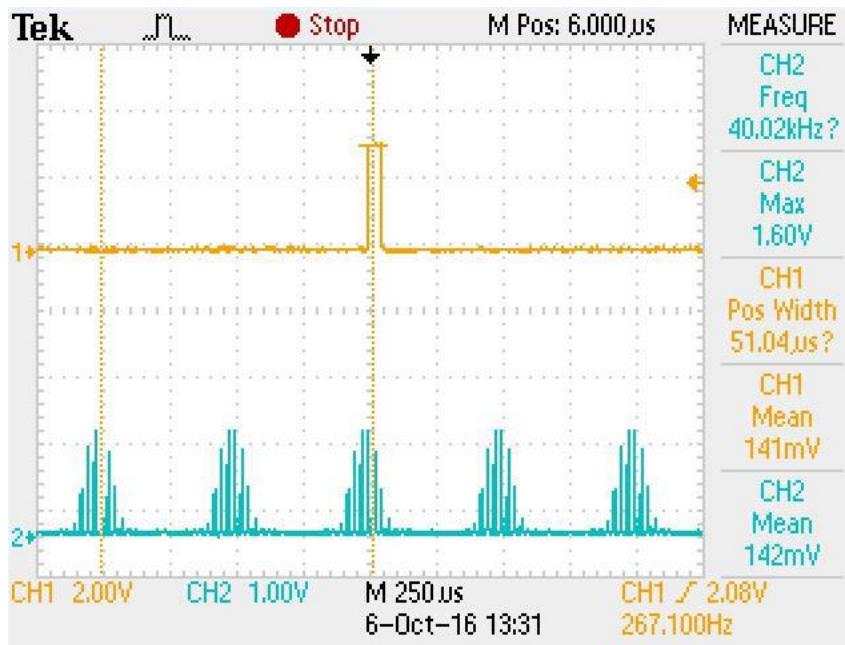

Figure 20. Ultrasonic signal in Piezo applied to Pin6, Output on Pin4 (0.050ms)

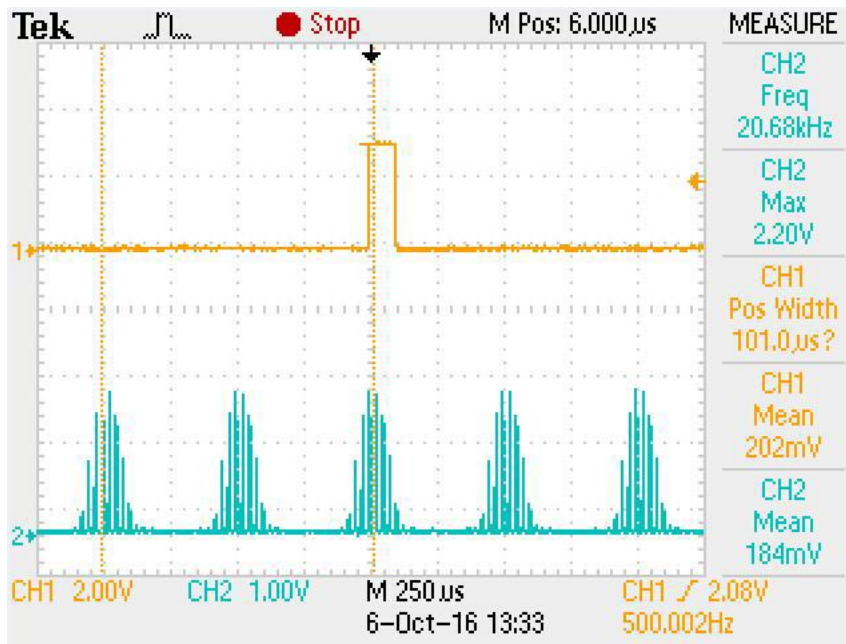

Figure 21. Ultrasonic signal in Piezo applied to Pin6, Output on Pin4 (0.100ms)

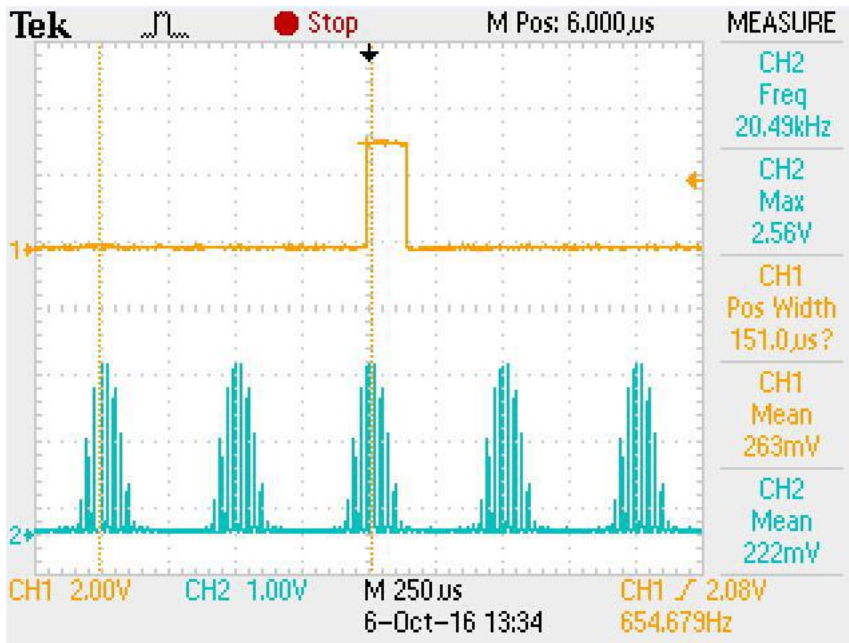

Figure 22. Ultrasonic signal in Piezo applied to Pin6, Output on Pin4 (0.150ms)

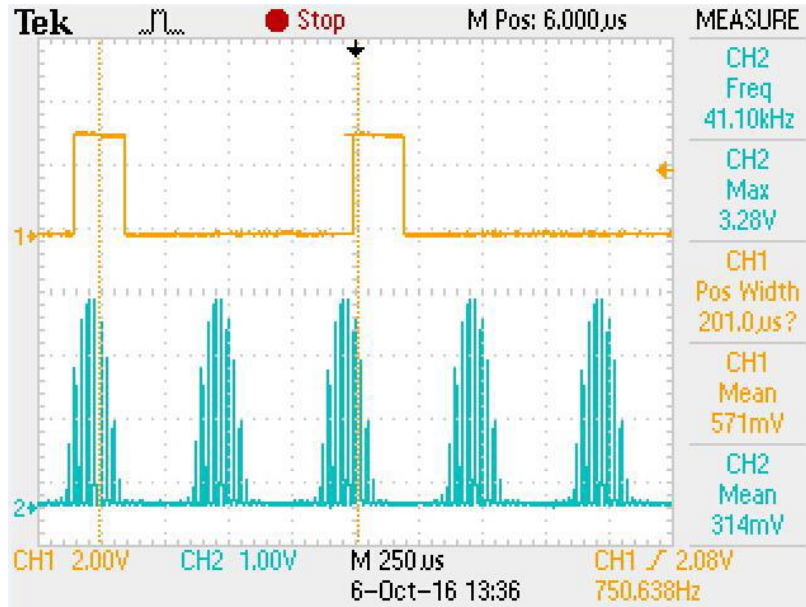

Figure 23. Ultrasonic signal in Piezo applied to Pin6, Output on Pin4 (0.200ms)

### 5.5 Output Stage

In this exercise, an 8 ohm speaker was used to transduce the output pulses via 2 stages: a 2N2222A transistor was used in the first stage and a BC558 was used in the 2nd; for driving the speaker.

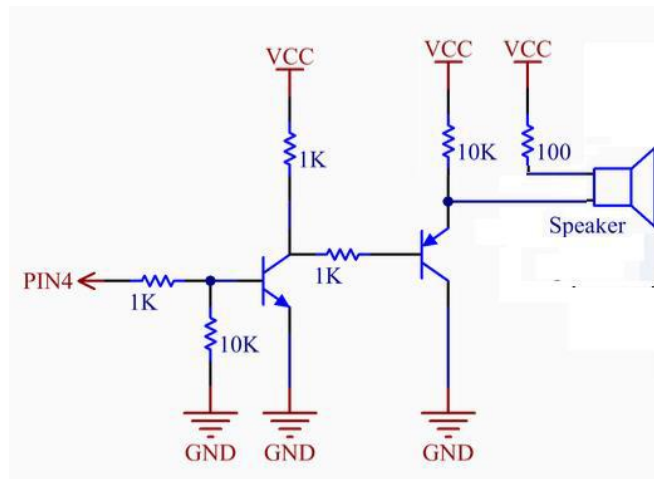

Figure 24. Speaker driver

## 6. Conclusion

This application explores the capabilities of basic logic, counters and delays in GreenPAK that can be used to enhance a concept that was, in the past, developed using basic TTL technology. It’s possible to add more features to get the outcome closer to the original source, such as varying the width of the pulse according to the input amplitude. This innovation to the standard detectors adds more value by informing us about the strength of the source. Even the distance parameters can be measured and presented in a visible indicator.

This Bat Detector offers new tools to identify the presence of these wonderful living creatures and lays the foundation for further developments in the attempt to identify frequency range, intensity, sequence, etc.

Many more options can still be added to this base design, such as digital data, or timeouts.

If we look at what lies ahead, this very same application can be extrapolated to have an audible signal proportional to the intensity of an ultrasonic wave, maybe reflected, such as in a proximity radar, impact prevention alert.

## 7. Revision History

Revision	Date	Description
1.00	November 7, 2016	Initial release.
2.00	April 30, 2026	The part number has been changed from SLG46531V to SLG46537V.

## IMPORTANT NOTICE AND DISCLAIMER

RENESAS ELECTRONICS CORPORATION AND ITS SUBSIDIARIES (“RENESAS”) PROVIDES TECHNICAL SPECIFICATIONS AND RELIABILITY DATA (INCLUDING DATASHEETS), DESIGN RESOURCES (INCLUDING REFERENCE DESIGNS), APPLICATION OR OTHER DESIGN ADVICE, WEB TOOLS, SAFETY INFORMATION, AND OTHER RESOURCES “AS IS” AND WITH ALL FAULTS, AND DISCLAIMS ALL WARRANTIES, EXPRESS OR IMPLIED, INCLUDING, WITHOUT LIMITATION, ANY IMPLIED WARRANTIES OF MERCHANTABILITY, FITNESS FOR A PARTICULAR PURPOSE, OR NON-INFRINGEMENT OF THIRD-PARTY INTELLECTUAL PROPERTY RIGHTS.

These resources are intended for developers who are designing with Renesas products. You are solely responsible for (1) selecting the appropriate products for your application, (2) designing, validating, and testing your application, and (3) ensuring your application meets applicable standards, and any other safety, security, or other requirements. These resources are subject to change without notice. Renesas grants you permission to use these resources only to develop an application that uses Renesas products. Other reproduction or use of these resources is strictly prohibited. No license is granted to any other Renesas intellectual property or to any third-party intellectual property. Renesas disclaims responsibility for, and you will fully indemnify Renesas and its representatives against, any claims, damages, costs, losses, or liabilities arising from your use of these resources. Renesas' products are provided only subject to Renesas' Terms and Conditions of Sale or other applicable terms agreed to in writing. No use of any Renesas resources expands or otherwise alters any applicable warranties or warranty disclaimers for these products.

(Disclaimer Rev.1.01)

### Corporate Headquarters

TOYOSU FORESIA, 3-2-24 Toyosu,  
Koto-ku, Tokyo 135-0061, Japan  
[www.renesas.com](http://www.renesas.com)

### Trademarks

Renesas and the Renesas logo are trademarks of Renesas Electronics Corporation. All trademarks and registered trademarks are the property of their respective owners.

### Contact Information

For further information on a product, technology, the most up-to-date version of a document, or your nearest sales office, please visit [www.renesas.com/contact-us/](http://www.renesas.com/contact-us/).