

**Introduction**

While it can be challenging to design electronic versions of precision tools, we propose in this application note to design an electronic level that matches the features of a conventional tool.

First, we will present a brief history of leveling tools. Then, we will describe the circuitry required to manage the signal received from an accelerometer. We will then discuss the internal design for a Programmable Mixed-Signal ASIC which performs the main functions of the electronic tool. We chose to use the GreenPAK™ SLG46120V for this app note thanks to its size and flexibility. Finally, we will show our visual and audible interface.

**History and secrets of the leveling tool**

A level is a tool designed to tell the user whether a surface is straight in the horizontal (also known as level) or vertical (also known as plumb) directions.

This simple piece of information is vital to brickwork, metal work, and carpentry. The design has essentially stayed unchanged for decades – a basic level contains a glass vial that is completely filled with liquid except for a small bubble. Due to the combined action of gravity and density differences, the bubble always moves to the highest point of the vial as gravity acts on the liquid inside the vial’s curved surface.

Figure 1 illustrates an exaggeration of the glass vial which highlights how it works. Figure 1(a) shows the bubble is centered when the vial is perfectly horizontal. In Figure 1(b), the bubble migrates to the highest point when the vial is rotated. Notice that the old position marked as faded bubble has a lower height. Since the bubble is less dense, it always floats toward the top of the curved vial surface.

**Leveling tool design**

Despite the simple mechanism, it is critical that the leveling tool performs with very high precision. The sensitivity is an important specification for a level, as it plays a big part in determining the overall accuracy of the device. The sensitive nature of a level is the change of angle or gradient required to move the bubble by a set distance. If the vial has graduated divisions, then the sensitivity refers to the angle or gradient change needed to move the bubble by one of these divisions.

The sensitivity is directly related to the radius of the curvature of the vial. The longer the radius, the more sensitive the vial will be, and vice versa. For this application note, we will use a simple bubble level as a reference. These simple levels do not come with a sensitivity specification, but it is possible to roughly measure its sensitivity by using a ruler and a caliper. Figure 2(a) shows the real bubble level tool used as a reference in this application note.

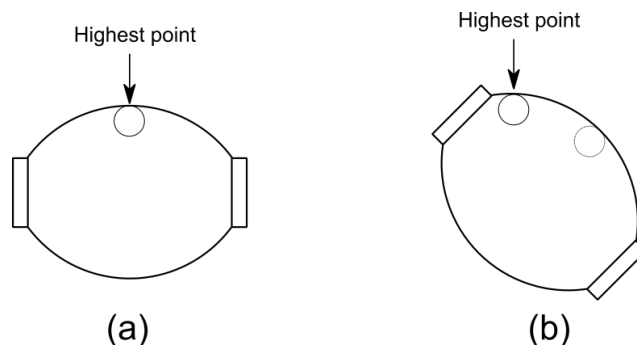

**Figure 1. Exaggerated glass vial and bubble behavior**



(a)

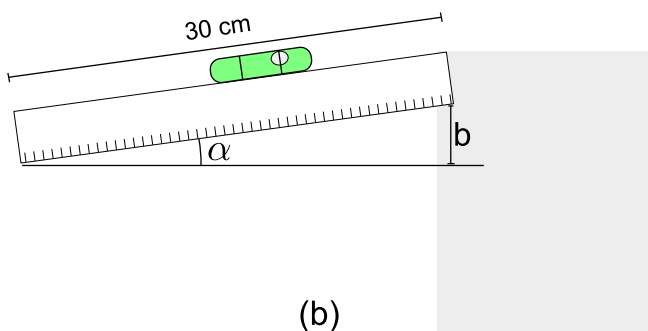

(b)

**Figure 2. Actual level and rough sensitivity measurement scheme**

For the measurement, we used a 31cm long ruler and placed a general level over it. Figure 2(b), shows the ruler touching the surface at one end while raising the other. We used the caliper to measure the height at the raised side. The bubble rests in the middle of the vial when the ruler is parallel to a plane surface. In this case, the value of  $\alpha$  is zero. Then, we raised one end of the ruler until it reached the first black mark and recorded the height, which is the variable 'b' denoted in Figure 2(b). The sensitivity is calculated using the following formula:

$$\alpha = 2 \arctan\left(\frac{b \text{ cm}}{31 \text{ cm}}\right) = 2 \arctan\left(\frac{0.85}{31}\right) = 3.14^\circ$$

Thus, the sensitivity between the two black marks is 3.14°. Our goal is to design an electronic level that is at least as good as the bubble level.

Next, we need to discuss the electronics used to create the electronic level which have impact on the sensitivity.

The sensitivity relates directly to the features of the gravity sensor. In this application note, we used the NXP accelerometer **MMA7260QT**. This device features signal conditioning, a 1-pole low pass filter, temperature compensation and the ability to select between four sensitivity settings. The average current consumption of the device is 500µA during operation, but it drops down to 3µA after entering sleep mode.

The NXP accelerometer's VDD requirements are 2.2V-3.6V since this is considered a low power application. The maximum sensitivity is 800mV/g at 1.5g, which is its default configuration. The output value of the acceleration variable is an analog voltage, and when the designer is interested only on the gravity vector, the output voltage can be described according to the following formula:

$$V_y(\alpha) = V_s g_y = V_s g \sin(\alpha) = 0,8 \sin(\alpha),$$

- $V_y(\alpha)$  is the accelerometer voltage output.
- $\alpha$  is the angle with respect to the g.
- $V_s$  is the sensitivity voltage in V/g.

$\alpha$	$V_y(\alpha)$
-1.57°	-0.0219 V
-0.7850°	-0.0110 V
0°	0 V
0.7850°	0.0110 V
1.57°	0.0219 V

**Table 1. Voltage values for sensitivity**

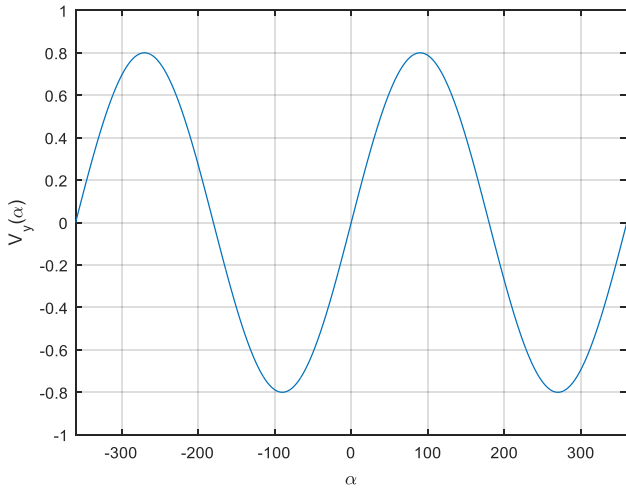

**Figure 3. Accelerometer output when it is fully rotated**

The sensitivity will scale linearly with the supply voltage. This means that as the supply voltage linearly increases, the same happens to the sensitivity and offset. Table 1 shows values of  $V_y(\alpha)$  for values of  $\alpha$  inside the range of the sensitivity measured before.

Figure 3 illustrates the effect of rotating the accelerometer in the angle range of  $-360 < \alpha < 360$ . Values very close to zero are nearly linear, which is very desirable in our design.

**Solution Architecture**

This section of the app note will describe the building blocks of the electronic leveling tool and detail how the circuit is constructed.

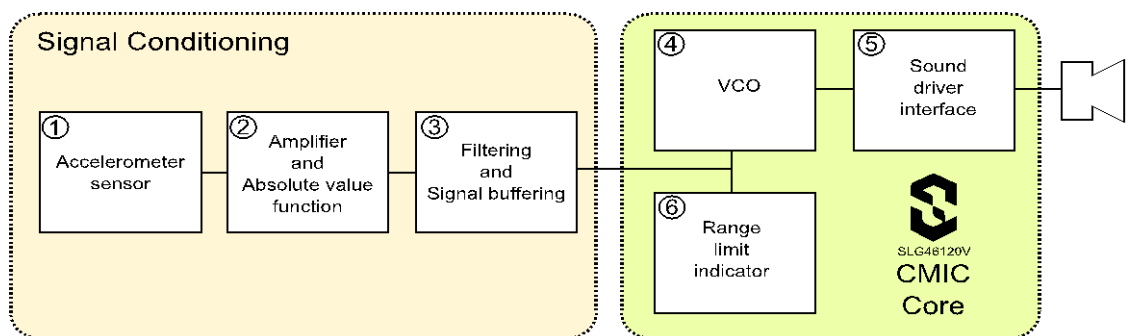
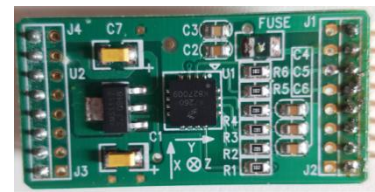

**Figure 4. System Block Diagram**

We start with Figure 4, which shows a complete block diagram of the system. The design has two main sections: Signal Conditioning and the GreenPAK IC Core. The tan box contains the blocks that generate and condition the signal, and the green box contains the GreenPAK integrated circuit and its support parts as RC timing network, audio driver, and a visual indicator. The GreenPAK SLG46120V IC was chosen to perform multiple functions, including an oscillator, sound driver, and LED array.

**External Circuits**

Figure 5(a) shows the module board and Figure 5(b) shows the pinout of the Accelerometer sensor.



(a)

	GND
	VDD
	Sel2
	Sel1
	X
	Y
	Z
	Sleep

(b)

**Figure 5. Accelerometer module and pinout**

Block 1 is composed of an off-the-shelf accelerometer sensor module which performs the acquisition of the gravity vector projection measure in its axis. The output is an analog signal in which the voltage is proportional to the projection of the gravity vector in one of three axes.

The Sel1 and Sel2 pins are two input pins which allow the user select the sensitivity of the accelerometer. By leaving SEL1 and SEL2 unconnected, the default sensitivity is 1.5g thanks to pull-down resistors connected to the inputs. The Sleep pin will be connected directly to VDD since we only want to demonstrate the basic function of the electronic level tool. If desired, the user can implement wake-sleep functionality to reduce power consumption by changing the implementation of the GreenPAK design.

Next, we condition the signal to make it suitable to drive the VCO of the GreenPAK design. We first start by referring back to Figure 3 where we take y axis as reference. We are now interested only in big variations of the signal provided by the function  $V_y(\alpha)$ . According to Figure 6, we notice that the sensor sensitivity of the green shaded area is greater than the blue shaded area due to the voltage variation.

The advantage of the green region is the linearity property. The variation of  $V_y(\alpha)$  can be considered linearly proportional to the variation of  $\alpha$  if  $\alpha$  assumes values very close to zero. This is possible due to the sine approximation defined as:

$$\sin(\alpha) \approx \alpha$$

We cannot apply the sine approximation for the blue shaded region and the low variation of the function  $V_y(\alpha)$ , for those values of  $\alpha$  is more susceptible to noise.

Leveling is a process where the user turns the device until  $\alpha$  reads zero. We use a sound interface to indicate when this happens. Since level is binary information (it is or it is not level), we establish that a sound signal below a maximum frequency is out of level. Thus, we must change the shape of the input signal to let us know when  $\alpha = 0^\circ$  is read. This task is accomplished by using the absolute value function on  $V_y(\alpha)$  for values of  $\alpha$  in the green shaded region. The result is highlighted in Figure 7, where Figure 7(a) indicates the original signal and Figure 7(b) indicates the result of the absolute value function circuit. Notice the red circle indicating a point of maximum when  $\alpha = 0^\circ$ . Then, the device is level when the user turns the device until it reaches highest pitch.

The Block 2 describes the "absolute value function". The signal conditioning is achieved with a circuit based on the SLG88104V. This part is a package of four CMOS operational amplifiers capable of rail-to-rail input and output operation.

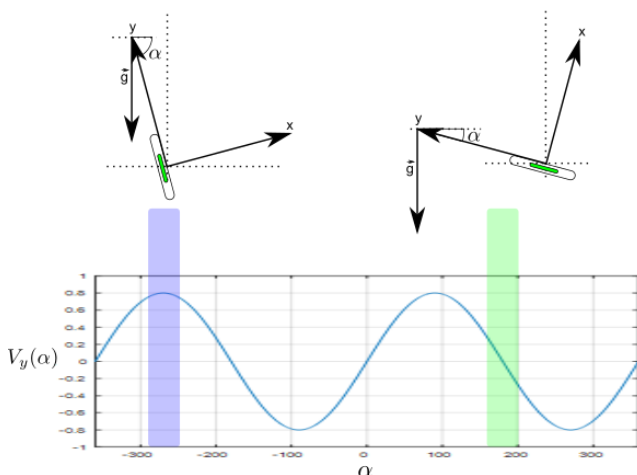

Figure 6. Accelerometer signal output and voltage variation highlight

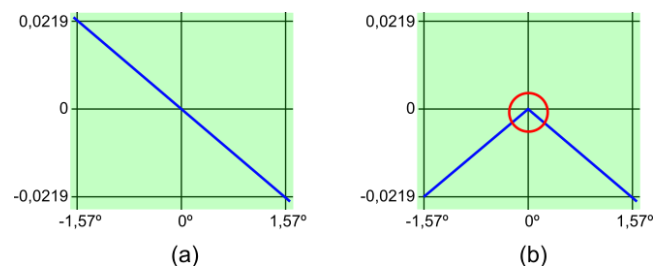

Figure 7. Absolute function applied on shaded green region

The main advantages of this part are the low current consumption of 375nA, its wide voltage range, and it's very small area footprint. Another useful feature is the individual power down control over each amplifier making it suitable for low power applications.

Ratiometricity refers to the ability of the transducer to maintain a constant sensitivity over a range of supply voltage values. The accelerometer signal output offset voltage and sensitivity will scale linearly with applied supply voltage. The input of Block 2 also considers the accelerometer offset reference. Figure 8 shows a circuit diagram for performing absolute value function and amplification. The VGND circuit point scales linearly with applied supply voltage. Thus, ACCEL and VGND will have very close offset reference meaning that the virtual "zero volts" read from ACCEL will be very close to the the virtual "zero volts" of VGND reference. Thus, a circuitry for calibrating at ACCEL circuit point is only required if the offset error is not low enough.

A large voltage variation coming from the accelerometer due to small device rotations is a feature that we wish for our design.

That feature is related to sensitivity and it can be controlled by using amplification. The amplification changes the ratio between the variations of  $\alpha$  proportional to the output frequency of the voltage controlled oscillator (VCO). The R13 and R14 resistors compose a gain network of the last operational amplifier before the signal output labelled ABS. The operational amplifier is configured as a non-inverting amplifier and the gain is given as:

$$A_{Gain} = 1 + \frac{R14}{R13}$$

Figure 9 shows a plot to guide the designer how control the sensitivity of the device by adjusting the amplification factor  $A_{Gain}$ .

### GreenPAK Circuit

The last stage of the signal conditioning, denoted by Block 3, performs filtering and signal buffering. Figure 10 shows an overall schematic of the GreenPAK SLG46120V IC interfacing with external parts. The output signal from Block 2 is labelled ABS.

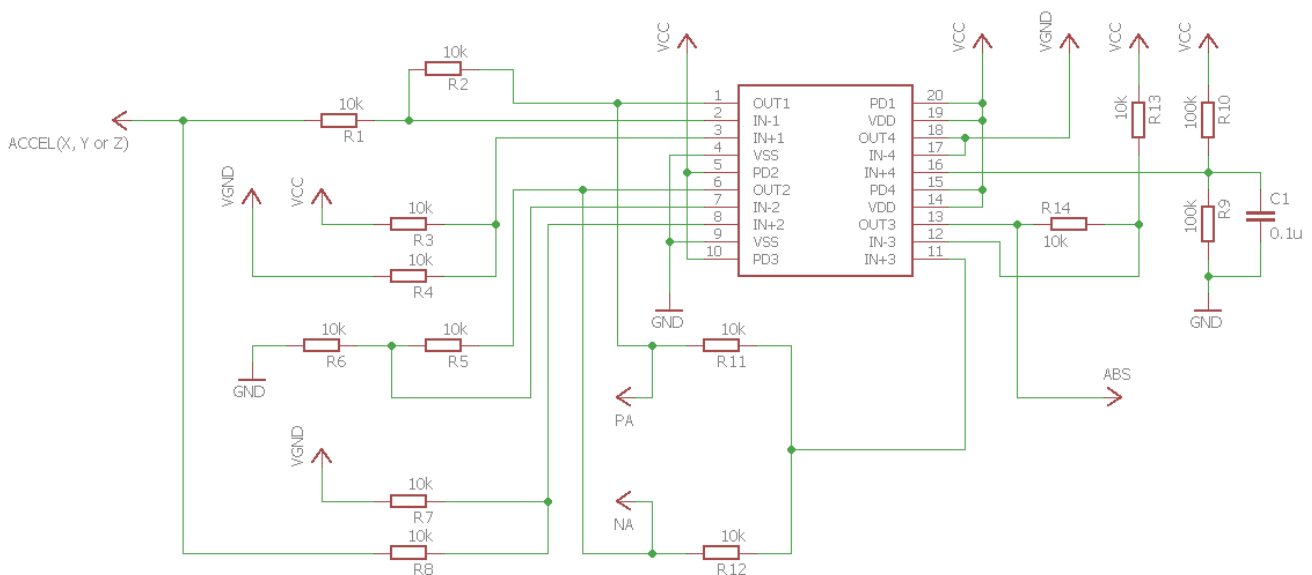

Figure 8. Circuit for amplification and inverted absolute value function with SLG88104V

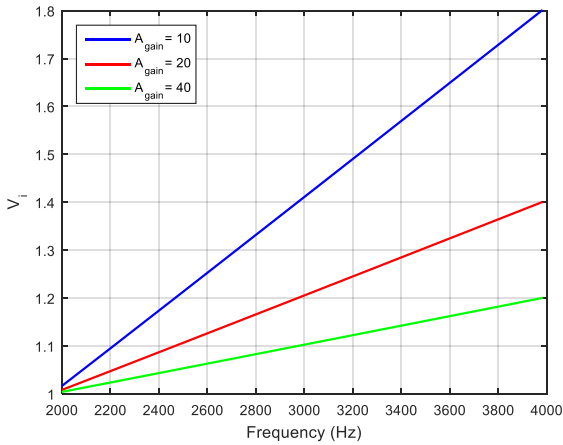

Figure 9. VCO output frequency as a function of gain

Next, the signal is filtered with a RC low-pass filter formed by R7 and C2, which is intended to eliminate the effects of sudden movements that may cause a glitch on the display or the sound driver. The accelerometer can detect physical collision which outputs high frequency noise that have to be filtered. Then, the output of the filter goes to a common collector amplifier topology (also known as an emitter follower) and it is used as a voltage buffer for the VCO driving.

R8 defines the offset used to control the highest tone pitch when  $\alpha = 0^\circ$ . The emitter of Q2 is connected to the time constant RC network R1 and C1 which controls the oscillation of the VCO. The parts Q1, R3, R4, and SP1 comprise the "Sound driver interface" block. The interface tone comes through speaker SP1 driven by transistor Q1 working as a switch.

The display interface is formed by an array of LEDs. LED1 and LED2 represent negative values for  $\alpha$ , LED4 and LED5 represent positive values for  $\alpha$ , and LED3 represents  $\alpha$  in a range of values very close to 0 degrees.

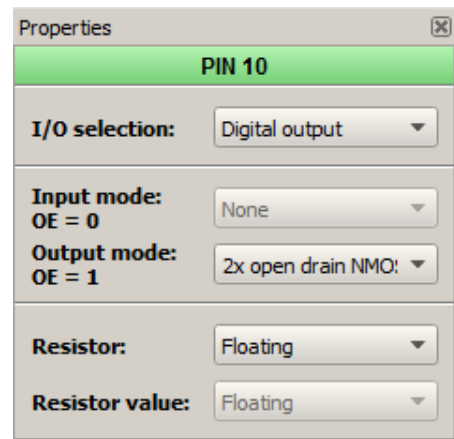

Figure 11. PIN 10 output properties

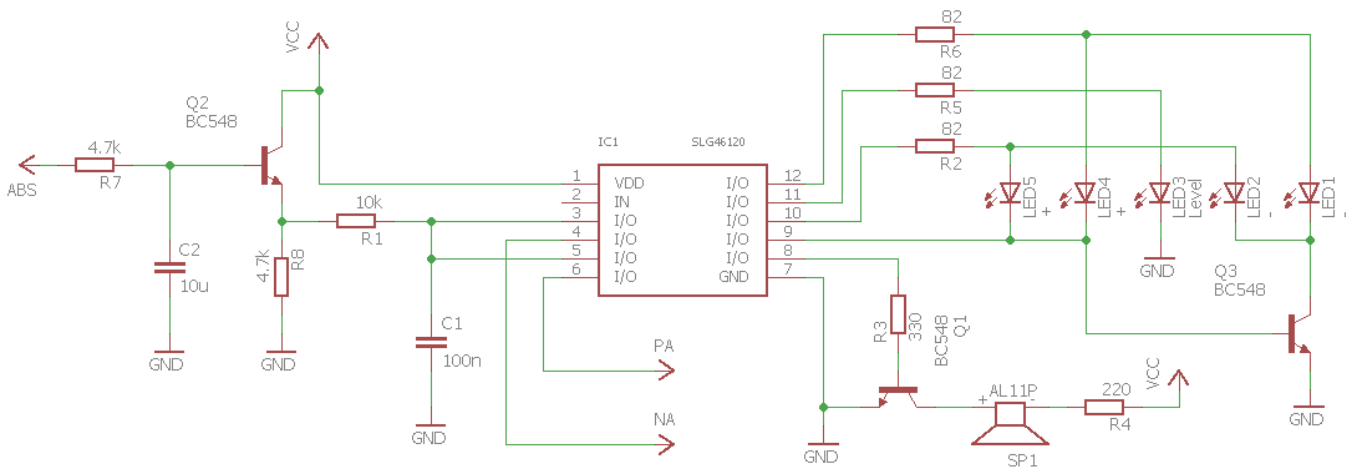

Figure 10. GreenPAK SLG46120V and external components



When the signal period decreases, or increases, that 2-bit counter will register a number and one out of three 3-bit LUTs will output HIGH according to their configurations. Table 2 shows which LUT and LED are active according to the Counter Register.

Since four bits is not enough to represent 5 angle values, we use a trick to achieve our objective. In Figure 12, notice that comparator ACMP1 is driving PIN9 which alternately shunts the positive and negative LED rails. Table 3 extends the logic of Table 2 including the signal result from ACMP1 and the reference accelerometer voltage from Table 1.

Counter Register	LUT	Active Pin
3	none	Hold display
2	3-bit LUT1	Pin 11
1	3-bit LUT8	Pin 12
0	3-bit LUT0	Pin 10

Table 2. Display events control

In order to create the sound driver in Block 5, we used the external RC network of the VCO to generate a maximum frequency of 4kHz. Since this frequency is high-pitched and can be uncomfortable for the human ear, we used two DFFs to lower it to a more pleasing 1kHz tone.

Design Test

One method to check if the device is working properly is to analyze the output of the VCO. We used an oscilloscope to measure the VCO output when excited by the signal coming from the accelerometer. Figure 13(a) shows the output when the tool is placed in the horizontal orientation, while Figure 13(b) shows the output when the tool is on an incline.

The blue and yellow lines denote the input and output signals, respectively. If the results in Figure 13 are compared with plot function in Figure 9 then you might conclude that the results are from a circuit set with  $A_{Gain} = 10$ .

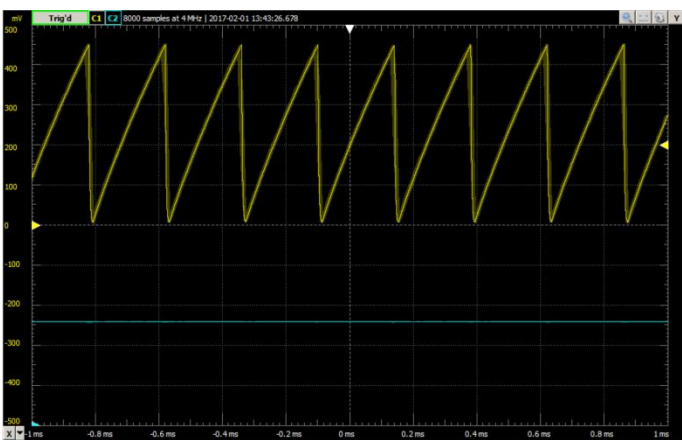

(a)

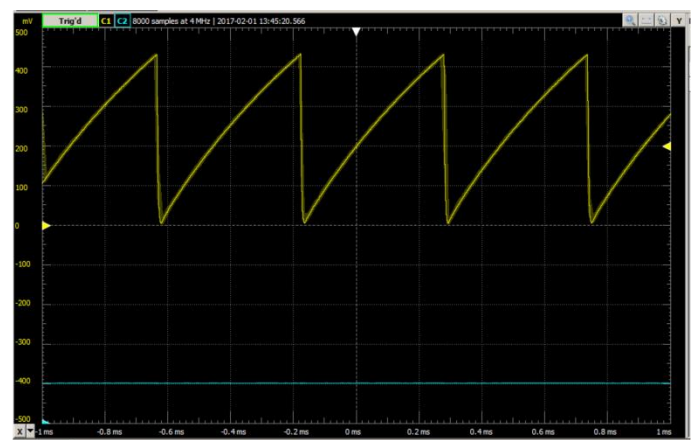

(b)

Figure 13. The VCO output according to horizontal alignment: (a) Input voltage of 1.8 Volts and frequency of 4.1 KHz, (b) Input voltage of 1.0 Volts and frequency of 2.1 KHz

Counter Register	LUT	Active Pin	ACMP1	Active Rail	LED	Accelerometer Voltage
3	No LUT	Hold display	+/-	Ignore	Hold display	Ignore
2	3-bit LUT1	Pin 11	Ignore	Ignore	LED3	0 V
1	3-bit LUT8	Pin 12	+	Pin 9	LED5	+0.0219 V
0	3-bit LUT0	Pin 10	+	Pin 9	LED4	+0.0110 V
2	3-bit LUT1	Pin 11	Ignore	Ignore	LED3	0 V
1	3-bit LUT8	Pin 12	-	Pin 8	LED2	-0.0110 V
0	3-bit LUT0	Pin 10	-	Pin 8	LED1	-0.0219 V

**Table 3. Extended display events**

## Conclusion

In this app note we constructed an electronic leveling tool. We designed the circuitry required to condition an analog signal from an accelerometer and an audible/visual user interface which indicates if the tool is level. The design worked as expected and we presented the signal plots in the design test section.

The combination of GreenPAK SLG46120V IC and SLG88104V Quad Op Amp provided ideal resources for designing this electronic level. The VCO structure was simple to construct, and there were plenty of resources to implement the audible interface and a visual indicator which let the user know how close the tool is to the horizontal plane.

## IMPORTANT NOTICE AND DISCLAIMER

RENESAS ELECTRONICS CORPORATION AND ITS SUBSIDIARIES (“RENESAS”) PROVIDES TECHNICAL SPECIFICATIONS AND RELIABILITY DATA (INCLUDING DATASHEETS), DESIGN RESOURCES (INCLUDING REFERENCE DESIGNS), APPLICATION OR OTHER DESIGN ADVICE, WEB TOOLS, SAFETY INFORMATION, AND OTHER RESOURCES “AS IS” AND WITH ALL FAULTS, AND DISCLAIMS ALL WARRANTIES, EXPRESS OR IMPLIED, INCLUDING, WITHOUT LIMITATION, ANY IMPLIED WARRANTIES OF MERCHANTABILITY, FITNESS FOR A PARTICULAR PURPOSE, OR NON-INFRINGEMENT OF THIRD-PARTY INTELLECTUAL PROPERTY RIGHTS.

These resources are intended for developers who are designing with Renesas products. You are solely responsible for (1) selecting the appropriate products for your application, (2) designing, validating, and testing your application, and (3) ensuring your application meets applicable standards, and any other safety, security, or other requirements. These resources are subject to change without notice. Renesas grants you permission to use these resources only to develop an application that uses Renesas products. Other reproduction or use of these resources is strictly prohibited. No license is granted to any other Renesas intellectual property or to any third-party intellectual property. Renesas disclaims responsibility for, and you will fully indemnify Renesas and its representatives against, any claims, damages, costs, losses, or liabilities arising from your use of these resources. Renesas' products are provided only subject to Renesas' Terms and Conditions of Sale or other applicable terms agreed to in writing. No use of any Renesas resources expands or otherwise alters any applicable warranties or warranty disclaimers for these products.

(Disclaimer Rev.1.01)

### Corporate Headquarters

TOYOSU FORESIA, 3-2-24 Toyosu,  
Koto-ku, Tokyo 135-0061, Japan  
[www.renesas.com](http://www.renesas.com)

### Trademarks

Renesas and the Renesas logo are trademarks of Renesas Electronics Corporation. All trademarks and registered trademarks are the property of their respective owners.

### Contact Information

For further information on a product, technology, the most up-to-date version of a document, or your nearest sales office, please visit [www.renesas.com/contact-us/](http://www.renesas.com/contact-us/).