

Using SLG59H1120V as a Backup Safety Power Switch in Consumer Applications

SLG59H1120V

Autonomous devices are being integrated into our homes due to expansion of IoT and robotic equipment into the consumer mass-market. One of the challenges for developers is fulfilling all the applicable requirements from certification authorities to meet compliance regulations. For instance, standard IEC60335-1 [1] defines safety requirements and is mandatory for all the consumer goods coming into a mass-market. For autonomous unattended devices, such as motor operated IoT controllers (solar controllers, automatic pet feeders, window controllers and others) or mobile robots (vacuum cleaners or similar), it is required to prevent DC motors from an overheating during a stall event. Regulation IEC60355-1 (chapter 19.11) specifies compliance standards for a single failure in electronics which can happen during the normal operation. This application note provides an elegant solution using High Voltage GreenFET technology device for both, switching off the power if required as well as performing current sensor functionality verification.

Contents

1. References	1
2. System Architecture	2
3. High Voltage GreenFET Concept and Capabilities	3
4. Application Circuit and Example Module	4
5. Test Setup	6
5.1 Test Software Algorithm	6
5.2 Hardware Test Setup.....	8
6. Tests	9
6.1 Test Procedures	9
6.2 Test Results.....	9
6.2.1. Turn On timing check	9
6.2.2. Current Sensor Verification Check.....	9
6.2.3. Overcurrent Event with Operational PWM Deactivation Function	11
6.2.4. Overcurrent Event with Malfunctional PWM Deactivation Function.....	12
7. Conclusion	12
8. Revision History	13

1. References

- [1] [IEC60335-1](#), Household and similar electrical appliances - Safety - Part 1: General requirements
- [2] [GreenFET™ Ultra-Low RDSON Load Switch Selector Guide](#), Product catalog
- [3] [SLG59H1120V Datasheet](#)
- [4] [Guidance document concerning functional safety of appliances using programmable electronic circuits](#).
Guidance document concerning functional safety of appliances has been updated by IEC TC61/MT23 based on meeting discussions during 2017.

2. System Architecture

Most systems nowadays contain a micro-controller with an application program running on it for the functionality implementation. If system contains parts, which may be unsafe for the end-consumer, like motors, linear drives, heating systems or similar, this controller is also typically used for the safety relevant functionality implementation. Requirements for the consumer grade goods are set by relevant standards, like IEC60335-1 [1] for household appliances. Sample architecture of the DC motor driver circuit is shown in Figure 1. DC motor here is being driven by a motor controller, which is powered from a power supply unit through the backup power switch, which is a second layer of deactivation protection for the motor controller. The switch can also be used as a power-saving element to deactivate the motor controller during the inactivity period.

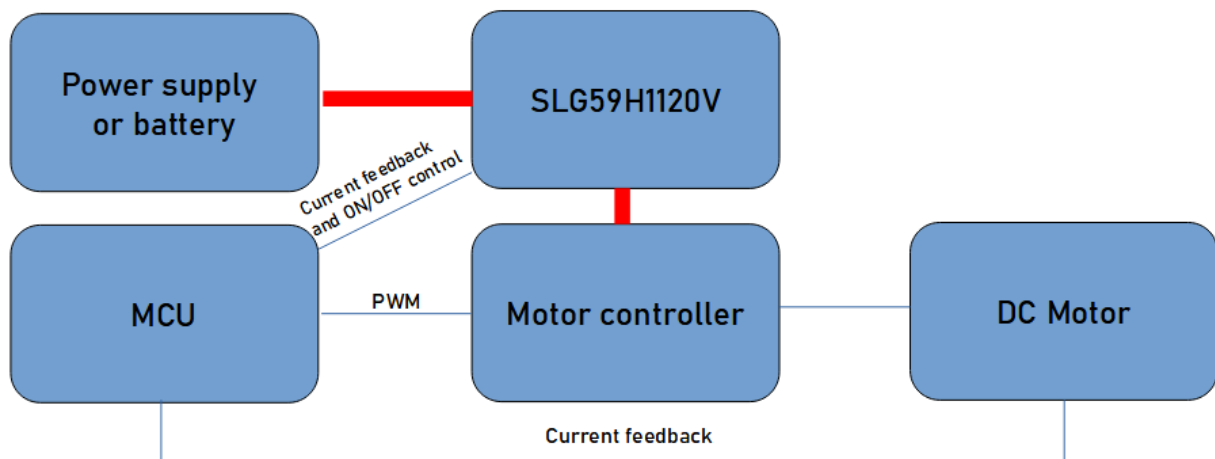

Figure 1. System Architecture

For the compliance, it is also important to provide a validation capability for a sensor subsystem in parallel with having a backup switch for the emergency motor drive deactivation. Useful here is a feature of SLG59H1x High Voltage GreenFET family – current monitor output. Almost all of them except SLG59H1127V have this output signal, so it is relatively easy to select a proper part, which can deliver necessary current for the required system voltage. Table 1 shows an extraction from the selection guide [2] for a quick overview of High Voltage GreenFET parts with the current monitor output capability. The FAULT output may be an interesting function, which allows using the built-in overcurrent, overvoltage or overtemperature protection. All the switches are sharing a STQFN-18 package, which dimensions are only 1.6 mm x 3.0 mm. This saves space on PCB. However, it requires additional attention be paid to PCB layout to fulfill cooling requirements.

Table 1. Component Selection Table [2]

For Applications up to 13.2 V

Part Number	Description	Max I_{DS} (A)	$R_{DS(ON)}$ (mΩ)	V_D/V_{IN} Min (V)	V_D/V_{IN} Max (V)	Power Supply (V_{DD}) Voltage Range (V)	Output Voltage Slew Rate set by	Protection Features*	Current/Power Monitor Output	Power Good, FAULT indicator	Output Discharge Circuit	Operating Temperature Range, (°C)	Package Size (mm)
SLG59H1127V	4.8 mm ² load switch with pin-selectable V_{IN} overvoltage protection, internal 5W nFET SOA protection, and Power Good Output	4	15	4.5	13.2	-	Capacitor	OVLO, UVLO, ACL(R), SCL, TSD	No	PG, FAULT	Yes	-40 to +85	STQFN-18 (1.6 x 3.0)
SLG59H1120V	4.8 mm ² load switch with pin-selectable V_{IN} overvoltage protection, internal 5W nFET SOA protection, and I_{DS} current monitor output	5	18	4.5	13.2	-	Capacitor	OVLO, UVLO, ACL(R), SCL, TSD	Current	FAULT	Yes	-40 to +85	STQFN-18 (1.6 x 3.0)
SLG59H1126V	4.8 mm ² load switch with pin-selectable V_{IN} overvoltage protection, internal 5W nFET SOA protection, and I_{DS} current monitor output	6	18	4.5	13.2	-	Capacitor	OVLO, UVLO, ACL(R), SCL, TSD	Current	FAULT	Yes	-40 to +85	STQFN-18 (1.6 x 3.0)

For Applications up to 25.2 V

Part Number	Description	Max I _{DS} (A)	RDS _{ON} (mΩ)	V _D /V _{IN} Min (V)	V _D /V _{IN} Max (V)	Power Supply (V _{DD}) Voltage Range (V)	Output Voltage Slew Rate set by	Protection Features*	Current/Power Monitor Output	Power Good, FAULT indicator	Output Discharge Circuit	Operating Temperature Range, (°C)	Package Size (mm)
SLG59H1013V	4.8 mm ² load switch with pin-selectable V _{IN} lockout protection, internal 5W nFET SOA protection, and I _{DS} current monitor output for enterprise printer/copier applications	3.5	13.3	10.8	25.2	-	Capacitor	OVLO, UVLO, ACL(R), SCL, TSD	Current	FAULT	Yes	-40 to +125	STQFN-18 (1.6 x 3.0)
SLG59H1017V	4.8 mm ² load switch with pin-selectable V _{IN} lockout protection, internal 10W nFET SOA protection, and I _{DS} current monitor output for enterprise printer/copier applications	4	13.3	10.8	25.2	-	Capacitor	OVLO, UVLO, ACL(R), SCL, TSD	Current	FAULT	Yes	-40 to +85	STQFN-18 (1.6 x 3.0)
SLG59H1008V	4.8 mm ² load switch with pin-selectable V _{IN} lockout protection, internal 5W nFET SOA protection, and I _{DS} current monitor output for enterprise printer/copier applications	4	13.3	10.8	25.2	-	Capacitor	OVLO, UVLO, ACL(R), SCL, TSD	Current	FAULT	Yes	-40 to +85	STQFN-18 (1.6 x 3.0)
SLG59H1010V	4.8 mm ² load switch with pin-selectable V _{IN} lockout protection, internal 5W nFET SOA protection, and I _{DS} current monitor output for enterprise printer/copier applications	5	13.3	10.8	25.2	-	Capacitor	OVLO, UVLO, ACL(R), SCL, TSD	Current	FAULT	Yes	-40 to +85	STQFN-18 (1.6 x 3.0)
SLG59H1019V	4.8 mm ² load switch with V _{IN} OVLO disabled, internal 10W nFET SOA protection, and I _{DS} current monitor output	5	13	4.5	25.2	-	Capacitor	UVLO, ACL(R), SCL, TSD	Current	FAULT	Yes	-40 to +85	STQFN-18 (1.6 x 3.0)
SLG59H1016V	4.8 mm ² load switch with pin-selectable V _{IN} overvoltage protection, internal 5W nFET SOA protection, and I _{DS} current monitor output	3.5	13.1	4.5	22	-	Capacitor	OVLO, UVLO, ACL(R), SCL, TSD	Current	FAULT	Yes	-40 to +125	STQFN-18 (1.6 x 3.0)
SLG59H1009V	4.8 mm ² load switch with pin-selectable V _{IN} overvoltage protection, internal 5W nFET SOA protection, and I _{DS} current monitor output	4	13.1	4.5	22	-	Capacitor	OVLO, UVLO, ACL(R), SCL, TSD	Current	FAULT	Yes	-40 to +85	STQFN-18 (1.6 x 3.0)
SLG59H1128V	4.8 mm ² load switch with pin-selectable V _{IN} overvoltage protection, internal 10W nFET SOA protection, and I _{DS} current monitor output	5	13.1	4.5	22	-	Capacitor	OVLO, UVLO, ACL(R), SCL, TSD	Current	FAULT	Yes	-40 to +85	STQFN-18 (1.6 x 3.0)
SLG59H1006V	4.8 mm ² load switch with pin-selectable V _{IN} overvoltage protection, internal 5W nFET SOA protection, and I _{DS} current monitor output	5	13.1	4.5	22	-	Capacitor	OVLO, UVLO, ACL(R), SCL, TSD	Current	FAULT	Yes	-40 to +85	STQFN-18 (1.6 x 3.0)
SLG59H1012V	4.8 mm ² load switch with pin-selectable V _{IN} overvoltage protection, internal 5W nFET SOA protection, and I _{DS} current monitor output	6	13.1	4.5	22	-	Capacitor	OVLO, UVLO, ACL(R), SCL, TSD	Current	FAULT	Yes	-40 to +85	STQFN-18 (1.6 x 3.0)
SLG59H1005V	4.8 mm ² back-to-back reverse-current blocking load switch with pin-selectable V _{IN} overvoltage protection, internal 5W nFET SOA protection, and I _{DS} current monitor output	3	50	4.5	22	-	Capacitor	OVLO, UVLO, ACL(R), SCL, TSD, RCB	Current	FAULT	No	-40 to +85	STQFN-18 (1.6 x 3.0)
SLG59H1020V	4.8 mm ² back-to-back reverse-current blocking load switch with pin-selectable V _{IN} overvoltage protection, internal 5W nFET SOA protection, and I _{DS} current monitor output	3	50	4.5	20	-	Capacitor	OVLO, ACL(R), SCL, TSD, RCB	Current	FAULT	No	-40 to +85	STQFN-18 (1.6 x 3.0)

* Notes:

1. ACL - Internally Fixed Active Current Limit
2. ACL(R) - External resistor-adjustable Active Current Limit
3. SCL - Internally Fixed Short-circuit Current Limit
4. Fixed ICL - Internally Fixed Inrush Current Limit
5. RVD - Reverse-voltage Detection

6. RCB - Reverse-current Blocking
7. TSD - Overtemperature protection (Thermal Shutdown)
8. UVLO - Undervoltage Protection
9. OVLO - Overvoltage protection
10. TVS - Internal Transient Voltage Suppressor

3. High Voltage GreenFET Concept and Capabilities

Renesas' High Voltage GreenFET is not only a classic load switch combining MOSFET and a driver, but is a fully protected overvoltage, overcurrent and overtemperature device. It has extended sensing capability which can be accessed externally. A conceptual block diagram of a High Voltage GreenFET SLG59H1120V [3] in an application example diagram is shown in [Figure 2](#).

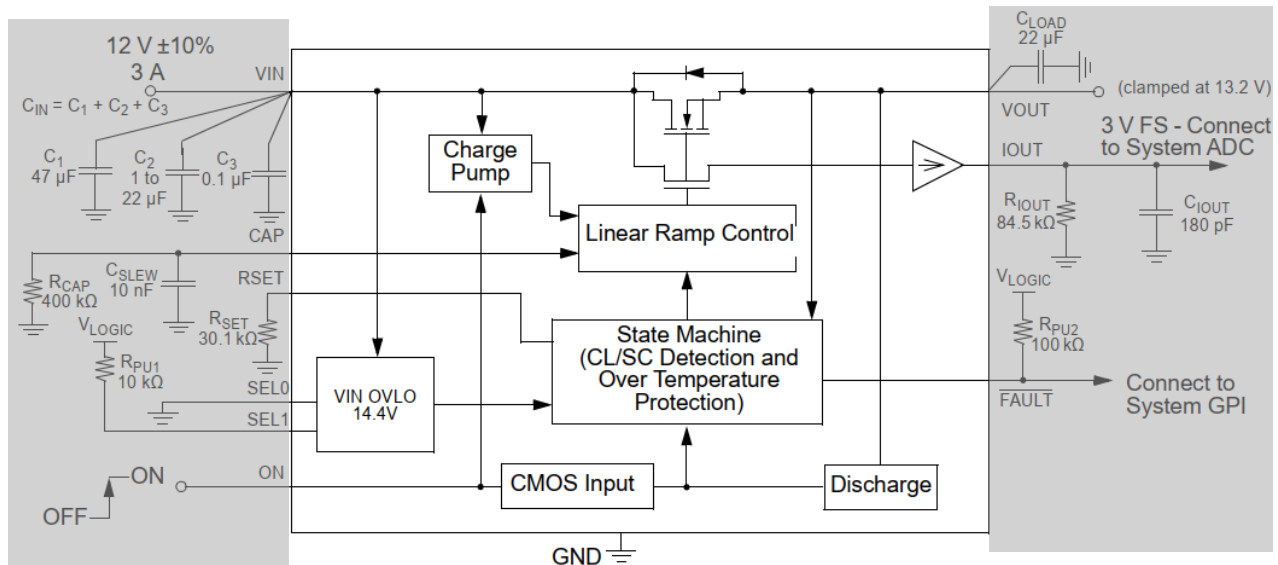

Figure 2. Block Diagram of SLG59H1120V

SLG59H1120V consists of main N-MOSFET working in switching mode driven through a charge pump and linear ramp control module. State machine defines the state of MOSFET according to the ON input and considering possible overrides from protection units: VIN OVLO – adjustable through SEL0/SEL1 overvoltage lockout, overcurrent – adjustable through the resistor settings on RSET input. MOSFET’s current is also mirrored to IOUT output and through a pull-down resistor can be transformed into a voltage signal, which can be used in the host system. FAULT shows the system state and allows easy detection of any protection event during the system operation. The combination of all these advanced features directly results in BOM (bill-of-material) component and cost reductions as well as increasing system reliability and reduced board size.

4. Application Circuit and Example Module

The DC motor driver circuit used alongside this application note, is shown in Figure 3. Here U4 is a DC motor driver. The A4950 or any other pin-compatible driver is commonly used. Shunt resistor R7 serves for current measurement purposes, whereas its voltage drop being amplified by U2A. The driver is powered through U3 SLG59H1120V connected to the host system and providing ON/OFF, fault output and current sense functionality. LDO U1 delivers secondary 3.3 V power supply for OPAMP U2A and sets reference voltage for motor driver U4. Second OPAMP U2B is bypassed and could be potentially used in other parts of the system. LED D2 indicates power supply state taken from 3V3 node, while D3 indicates power state of motor driver.

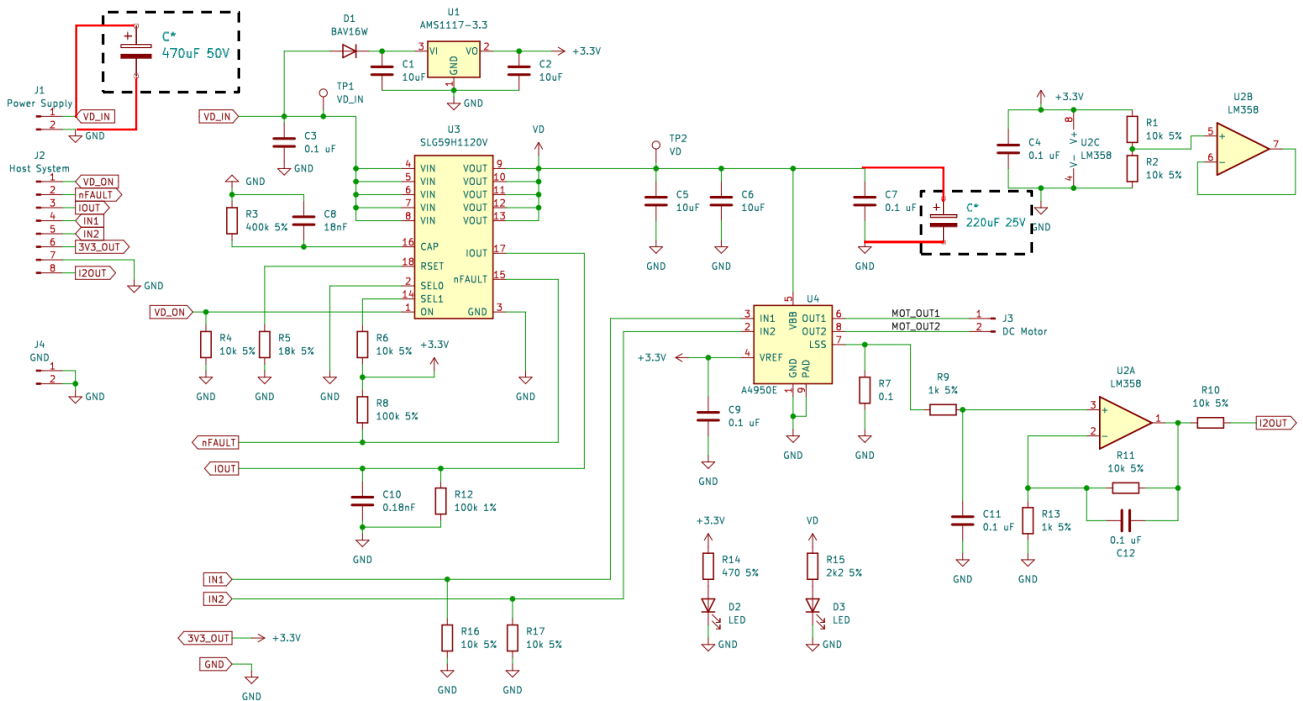

Figure 3. Schematic of a DC Motor Driver



Figure 4. Experimental Module PCBA Front/Back View

Total capacitance on VD_IN is built up from the filtering capacitor C3 and additional capacitors from the host system in total 470uF (finally it was also placed on the experimental module). It was found during the testing, that an overcurrent event on U3 can be triggered quite easily due to the high starting current of DC motor, thus an additional capacitor 220uF was placed on the power input of U4. There are two overcurrent thresholds set on the module, which will be triggering in hardware if an overcurrent event occurs. First one is set for U3 by R5 connected to RSET pin and adjusted to be 5 A. The second one is set for U4 by applying 3.3 V to VREF pin and adjusted to be:

$$I_{MAX} = \frac{VREF}{10 \times R7} = 3.3 A \quad (1)$$

Hardware limits are set for protecting electronic components from overcurrent. The power switch U3 could be driving more than a single motor driver. Applications like robotics, where more than 2-3 motors are normal. It makes sense to ensure no current throttling by the power switch to set limits higher.

Safety-related limit, which are set in firmware lower than the max current provided by the motor driver U4 in order to avoid current limiting from hardware below safety limits. This also guaranties clear order of overcurrent protection triggering, being first – in firmware, second – motor controller and the last – power switch. So, the hierarchical structure, which is recommended to support a safety architecture of the system is shown in Figure 5.

DC motor current limit is defined by measuring a winding temperature while motor being stalled and comparing the temperature value with such, given by IEC 60335-1 chapter 19.7 [1] shown in Table 2.

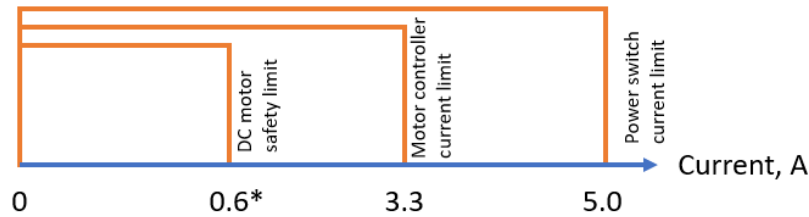

* Limit set in software for the particular motor and lay within a range of $0 < I < 3.3A$

Figure 5. Current Limits Hierarchy

Table 2. Limits of Winding Temperature for Stalled DC Motor

Type of appliance	Temperature °C							
	Class A	Class E	Class B	Class F	Class H	Class 200	Class 220	Class 250
Appliances other than those operated until steady conditions are established	200	215	225	240	260	280	300	330
Appliances operated until steady conditions are established – if impedance protected	150	165	175	190	210	230	250	280
– if protected by PROTECTIVE DEVICES								
• during the first hour, maximum value	200	215	225	240	260	280	300	330
• after first hour, maximum value	175	190	200	215	235	255	275	305
• after first hour, arithmetic average	150	165	175	190	210	230	250	280

Two different current sense signals IOOUT and I2OUT are essential for IEC60335 compliance, as standard requires plausibility check for the sensor subsystem, which is preformed by the firmware comparing two current measurement signals of two different nature in current sensor verification block (see Figure 6). Application circuit was implemented as an experimental module PCB for testing and functionality verification. The module is shown in Figure 4. It is implemented on two-layer PCB and provides pinout headers for a host system, DC motor and power supply.

5. Test Setup

For testing the circuit in the application, host system was simulated through an Arduino-based controller, which was used for the activation/deactivation PWM of the motor, validation of sensing and backup power deactivation in case the main one doesn't work. Despite the fact, that the tester's software was not implemented in accordance with IEC60335-1 Annex R (Software evaluation) [4], as this is not the main focus of the application note, main principle of operation is well shown and can be re-used in a real application without significant additional effort.

5.1 Test Software Algorithm

The Test software algorithm is shown in Figure 6. Operation starts with enabling of VD power supply by setting VD_ON active. The Current sensor verification block sets a sample PWM for the motor and checks, whether current measurement of motor driver, I2OUT is inline with the measurement coming from High Voltage GreenFET IOOUT. If not, then system is considered broken, the driver power is set deactivated, and the system state lands

into Eternal STOP. This is the state where all system functions are deactivated, and a user notification is set. If current sensor verification is successful, then the motor operation is allowed.

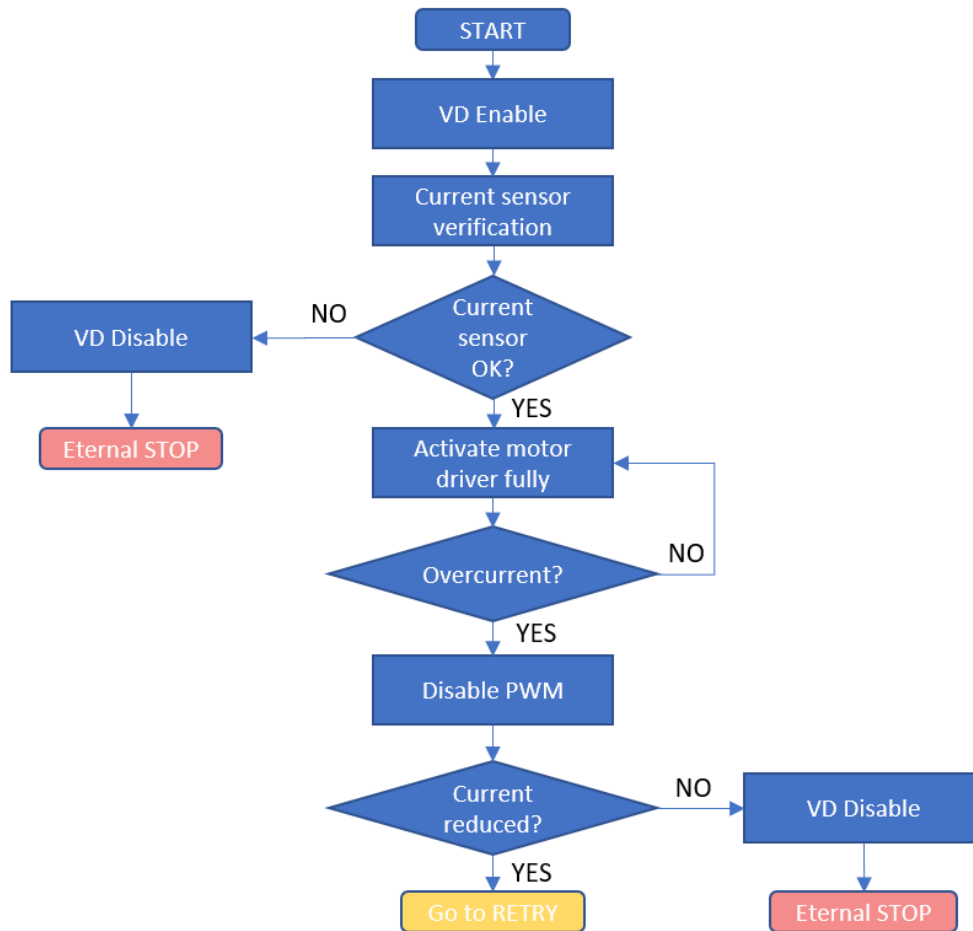

Figure 6. Safety Procedure Example Algorithm

During the operation, current measurement I_{OUT} is being regularly checked and in the event of overcurrent the PWM is deactivated. To make the system robust against short term transitions, a counter is used to signal the overcurrent if the DC motor current is higher than the set limit during $T = 1.5$ seconds. This value must be selected after motor evaluation to ensure a big enough margin over transients and to guarantee, that winding temperature is not coming close to the limiting values from Table 2. Averaging for $\Delta T = 300\text{ms}$ is used during the current sense signal acquisition, thus T has a tolerance up to ΔT , which, considering slow thermal processes of DC motor winding heating is perfectly acceptable. Shaft lock threshold must be low enough to ensure lock event detection within the whole range of the PWM but must not be triggered during normal transient overloads.

In the application example the threshold is set for $I_{lock} = 700\text{mA}$. If current is going lower after shaft lock detection and PWM deactivation, then the system is set for a “RETRY”, to restart the operation. The dangerous event is not necessarily permanent. In case of current sensor measurement are still staying high – i.e. the current is still flowing through the motor despite PWM being set OFF and not decreasing within 300 ms – power of the motor driver is cut by deactivating VD through the backup power switch and system lands into “Eternal STOP” (see Figure 13 for an example).

5.2 Hardware Test Setup

An example host system and the experimental module for the backup power switch based on SLG59H1120V (Figure 4) were built in one system on a standard prototyping PCB card and shown in Figure 7. Core of the host system – Arduino PRO Mini is connected through the USB ↔ UART adapter to a development computer. The experimental module is connected to the host system as listed in Table 3. A Failure insertion switch is interrupting PWM signal routed to IN2 and connects it to a permanent 3.3 V of the Experimental Module, simulating a short circuit on the PCBA causing a hardware failure. A typical DC Motor 500-size (no load current is about 50-100mA, stall current is about 2.5A) is connected to the output of the experimental module and is used for the load simulation. Power input is connected to the laboratory power supply unit setup for 12V.

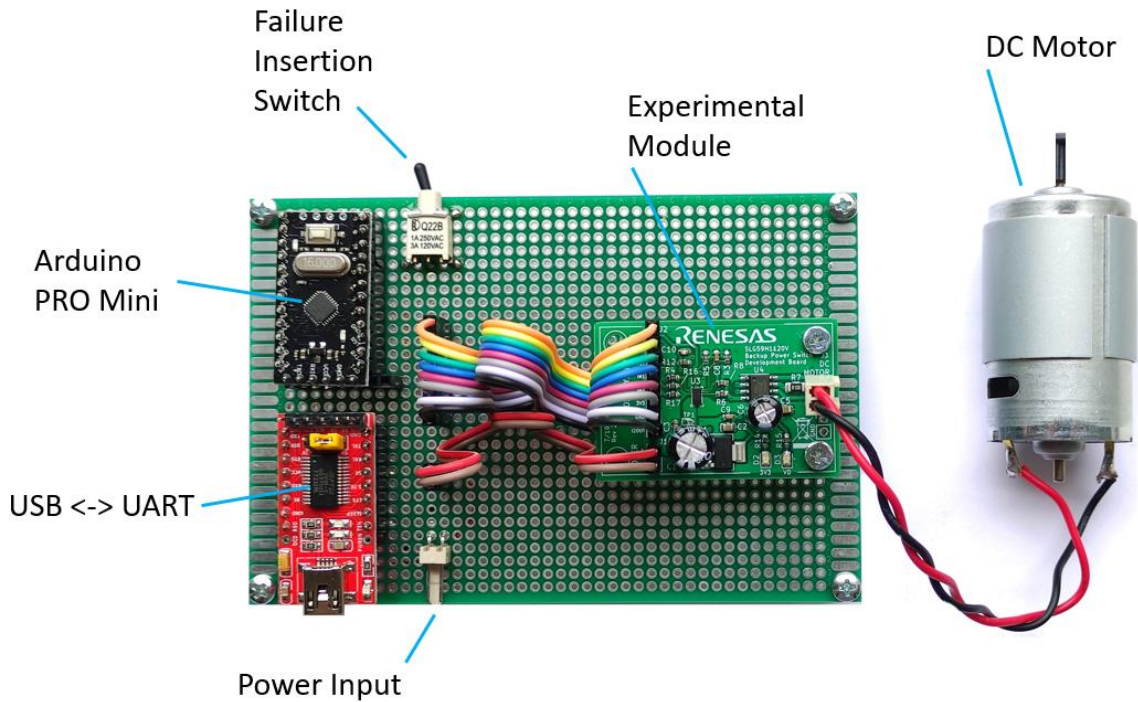

Figure 7. Hardware Test Setup

Table 3. Pinout of Host System Interfacing

Experimental Board Signal	ATmega168 pin	Arduino pin	Experimental Board Signal	ATmega168 pin	Arduino pin
VD_ON	PD2	2	IN2	PD6	6
nFAULT	PD3	3	3V3	N.C.	-
IOUT	PC0	A0	GND	N.C.	-
IN1	PD5	5	I2OUT	PC1	A1

6. Tests

6.1 Test Procedures

To ensure functionality of the module following tests were performed:

- Turn ON timing check
- Current sensor verification check
- Overcurrent event with operational PWM deactivation function
- Overcurrent event with malfunction of PWM deactivation function

6.2 Test Results

6.2.1. Turn On timing check

According to the datasheet of SLG59H1120V [3], ON Delay time shall be in the range of 0.7 to 1.2 milliseconds.

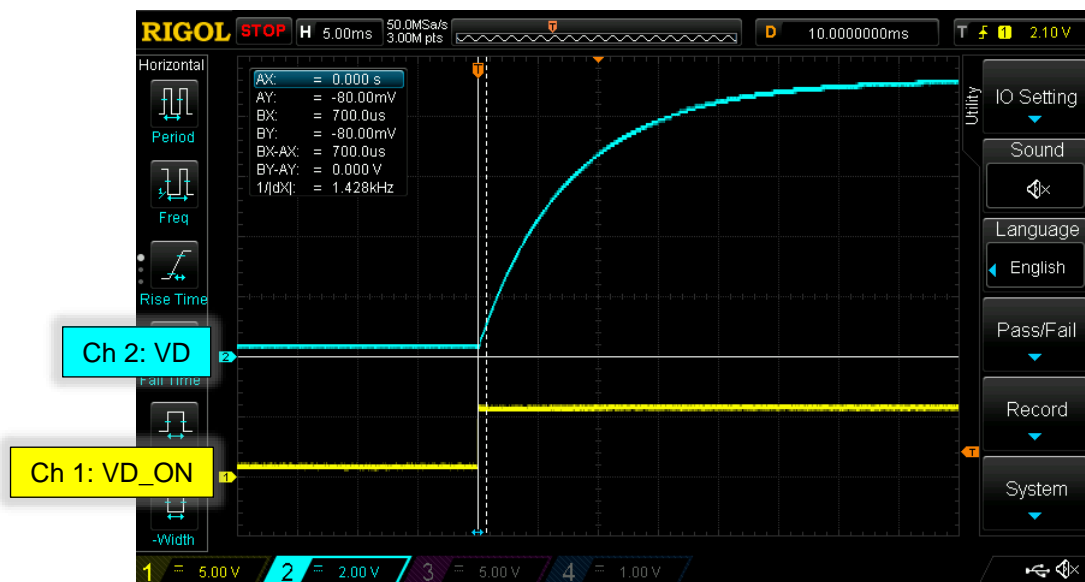

Figure 8. Turn ON Timing Check

As it is visible from Figure 8 timings are inline with the datasheet definition. On timing check is important for the system bootup sequence setup.

6.2.2. Current Sensor Verification Check

Current sensor verification is done by comparing the current coming from the U3 SLG59H1120V current sense output (IOUT) and low-side H-bridge measurement of U4 A4950 (I2OUT). It is important to ensure proper re-scaling of the current measurement, as the low-side H-bridge current may also include extra current caused by a back EMF of the DC motor (this is also dependent on the decay settings of U4) and thus has to be recalculated as following:

$$I_{2OUT} = I_{2OUT_RAW} \times PWM\% \quad (2)$$

U4 used in the application operates in the mixed mode, thus the back EMF induced current is not routed via low side current measurement resistor and recalculation is not necessary. Looking at Figure 9 - Figure 11 one can notice the effect of current measurement differences due to the nature of measurement circuits. Scaling factor of IOUT set to be 1 V/A and the scaling factor of I2OUT is:

$$f = \left(1 + \frac{R11}{R13}\right) \times R7 = 1.1 \text{ V/A}, \quad (3)$$

where $\left(1 + \frac{R_{11}}{R_{13}}\right)$ – amplification factor of U2A, R7 – value of the current sense shunt resistor. At the same time measurements are very much inline with each other, which allows simple verification in the beginning of operation by comparing the data from two circuits after calibrating them. According to the standard requirements the verification shall be done once in the operation cycle, so in the beginning of the algorithm (Figure 6) about 1s averaged samples are compared and in case of matching values current measurement circuits are assumed to be functional.

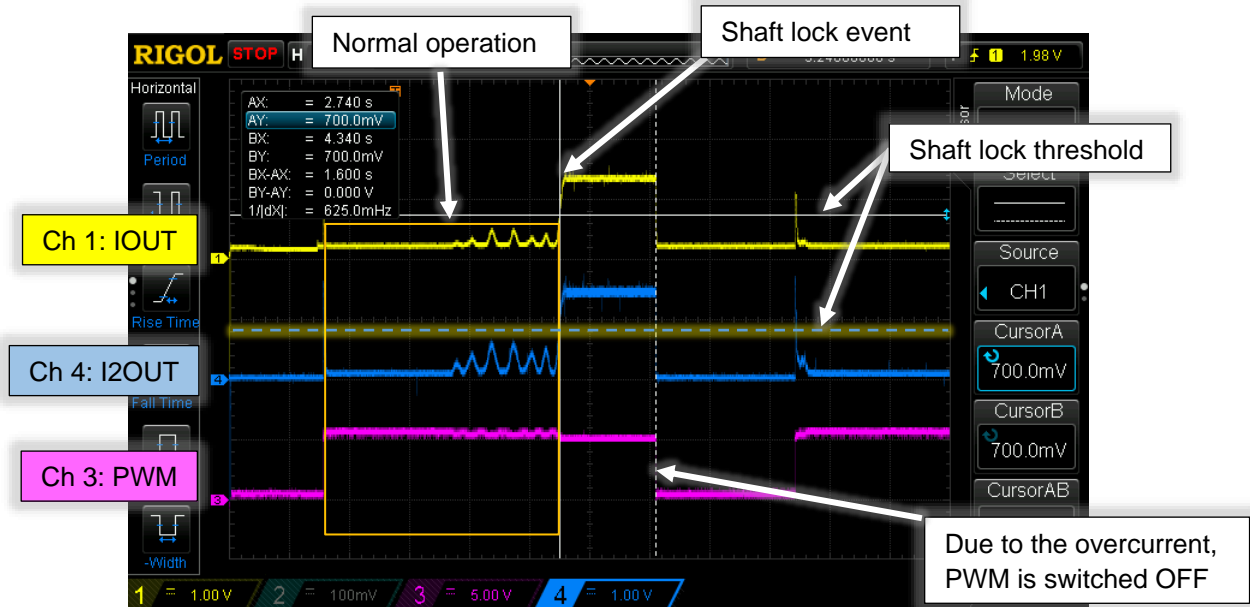

Figure 9. Current Measurement IOUT VS I2OUT Comparison Diagram @ PWM=100%. Motor is Free Running with Variable Load Until the Shaft Lock Event Happen and Overcurrent is Detected

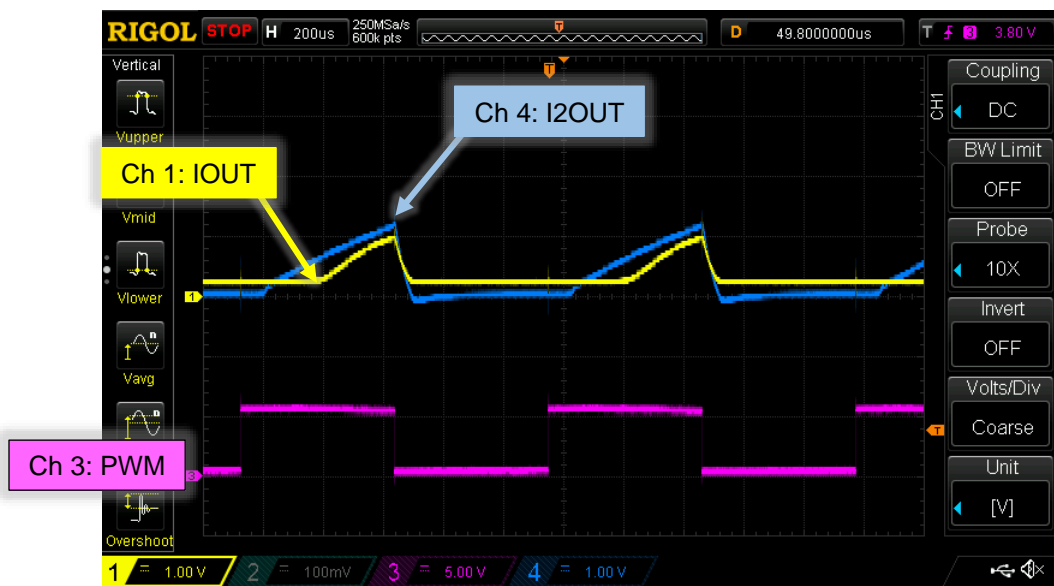

Figure 10. Current Measurement IOUT VS I2OUT Comparison Diagram @ PWM=50%. Scaling Factor of I2OUT is 1.1 V/A and IOUT 1.0 V/A

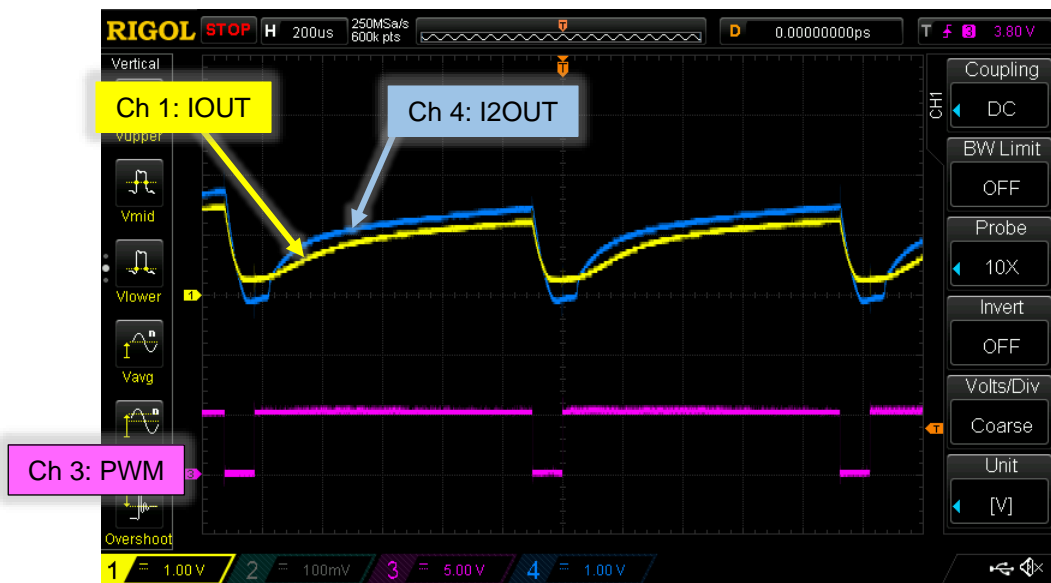

Figure 11. Current Measurement IOUT VS I2OUT Comparison Diagram @ PWM=90%. Scaling Factor of I2OUT is 1.1 V/A and IOUT 1.0 V/A

6.2.3. Overcurrent Event with Operational PWM Deactivation Function

In Figure 12 the signal diagram of an overcurrent event with operational PWM deactivation function is shown. Zone A corresponds to a normal operation, Zone B to the shaft lock event, and Zone C to deactivation time for a retry, which starts in Zone D. For a perception simplicity, this and following test are done with PWM level set to 100%, which allows easier displaying of signal diagrams. For the system operation PWM level is generally irrelevant as the system only checks current measurements and does not use PWM as an input for the state transition.

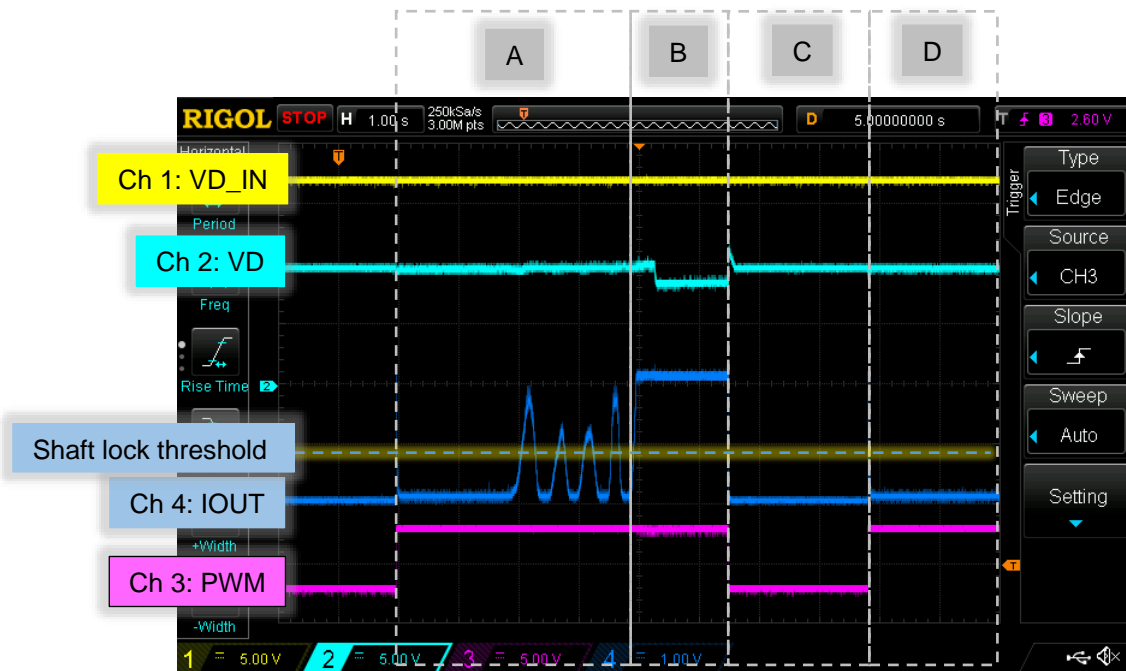

Figure 12. Signal Diagram of an Overcurrent Event with Operational PWM Deactivation Function

6.2.4. Overcurrent Event with Malfunctional PWM Deactivation Function

In Figure 13 the signal diagram of an overcurrent event with a malfunctional PWM deactivation function is shown. Zone A corresponds to a normal operation, Zone B to an event of PWM line damage (failure insertion switch is ON), and Zone C – shaft lock event and as PWM was not deactivated and resulting overcurrent is still there. As a result, the system is landing in “Eternal STOP” where deactivation of VD happens, which is shown in Zone D.

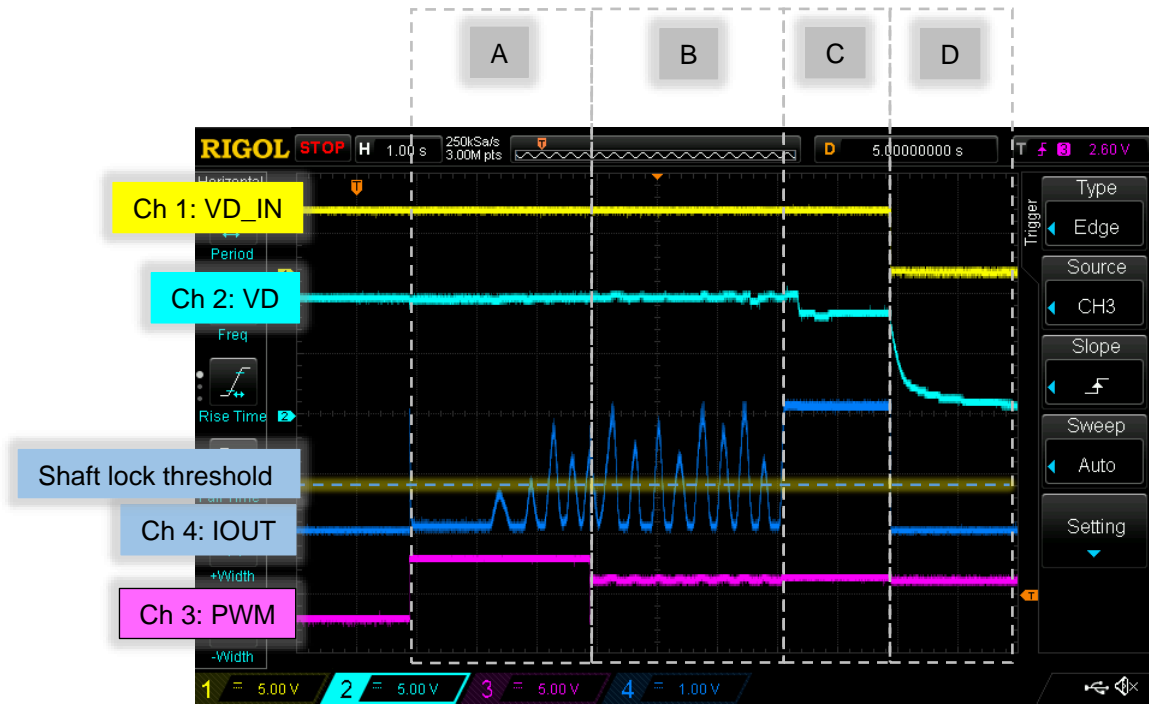

Figure 13. Signal Diagram of an Overcurrent Event with Malfunctional PWM Deactivation Function

Considering a dual deactivation and a dual current measurement, the backup switch keeps system safe even if a single hardware error occurs.

7. Conclusion

This application note shows the implementation of a backup power switch for DC motor driver intended for unattended consumer use. A clear advantage of High Voltage GreenFET products in this application is PCB real estate and BOM cost savings due to multiple functions integrated into a miniature single device. A system build with the help of a SLG59H1120V device can perform current sensor functionality verification and backup power deactivation when normal ways of deactivation fail. During the system planning, additional attention must be paid to the total capacitance on power lines to avoid sudden overcurrent switch-offs due to DC motor current spikes.

8. Revision History

Revision	Date	Description
1.00	Feb 13, 2023	Initial release.

IMPORTANT NOTICE AND DISCLAIMER

RENESAS ELECTRONICS CORPORATION AND ITS SUBSIDIARIES (“RENESAS”) PROVIDES TECHNICAL SPECIFICATIONS AND RELIABILITY DATA (INCLUDING DATASHEETS), DESIGN RESOURCES (INCLUDING REFERENCE DESIGNS), APPLICATION OR OTHER DESIGN ADVICE, WEB TOOLS, SAFETY INFORMATION, AND OTHER RESOURCES “AS IS” AND WITH ALL FAULTS, AND DISCLAIMS ALL WARRANTIES, EXPRESS OR IMPLIED, INCLUDING, WITHOUT LIMITATION, ANY IMPLIED WARRANTIES OF MERCHANTABILITY, FITNESS FOR A PARTICULAR PURPOSE, OR NON-INFRINGEMENT OF THIRD-PARTY INTELLECTUAL PROPERTY RIGHTS.

These resources are intended for developers who are designing with Renesas products. You are solely responsible for (1) selecting the appropriate products for your application, (2) designing, validating, and testing your application, and (3) ensuring your application meets applicable standards, and any other safety, security, or other requirements. These resources are subject to change without notice. Renesas grants you permission to use these resources only to develop an application that uses Renesas products. Other reproduction or use of these resources is strictly prohibited. No license is granted to any other Renesas intellectual property or to any third-party intellectual property. Renesas disclaims responsibility for, and you will fully indemnify Renesas and its representatives against, any claims, damages, costs, losses, or liabilities arising from your use of these resources. Renesas' products are provided only subject to Renesas' Terms and Conditions of Sale or other applicable terms agreed to in writing. No use of any Renesas resources expands or otherwise alters any applicable warranties or warranty disclaimers for these products.

(Disclaimer Rev.1.01)

Corporate Headquarters

TOYOSU FORESIA, 3-2-24 Toyosu,
Koto-ku, Tokyo 135-0061, Japan
www.renesas.com

Trademarks

Renesas and the Renesas logo are trademarks of Renesas Electronics Corporation. All trademarks and registered trademarks are the property of their respective owners.

Contact Information

For further information on a product, technology, the most up-to-date version of a document, or your nearest sales office, please visit www.renesas.com/contact-us/.