Determination of Failure In Time within the AEC-Q100 GreenPAK™ Family Automotive GreenPAK

The purpose of this document is enabling the usage of the GreenPAK family in industrial and automotive safety related applications compliant with IEC 61508 and/or ISO 26262.

Contents

1. Introduction	4
1.1 Intended Audience	4
2. Parameters	5
3. Assumptions	5
4. Functional Description	6
5. Requirements for E/E/PE system Implementation Based on IEC 61508	7
5.1 Failure Mode Analysis	7
5.2 Failure Rate Analysis	9
5.2.1. Consideration of Common Cause Failure	22
5.2.2. Propagation delay and response times	22
5.3 Environmental Range	22
5.4 Lifetime Reliability Reports	22
6. Case Study: Example of Failure Rate Analysis	23
6.1 General Analysis	23
6.2 Detailed Analysis	25
7. Conclusion	27
8. Revision History	28

Terms and Definitions

ACK	Acknowledge bit
ACMP	Analog Comparator
ACMPH	Analog Comparator High Speed
ACMPL	Analog Comparator Low Power
AoU	Assumption of Use
ASICs	Application Specific Integrated Circuits
BG	Band Gap
CLK	Clock
CMO	Connection matrix output
CNT	Counter
CL	Confidence Level
DFF	D-Type Flip-Flop
DLY	Delay
DC	Diagnostic Coverage
DFB	Diagnostic Fault Band
ESD	Electrostatic Discharge
EV	End Value
FSM	Finite State Machine
GND	Ground
GPI	General Purpose Input
GPIO	General Purpose Input/Output
GPO	General Purpose Output
IC	Integrated Circuit
IN	Input
IO	Input/Output
LPF	Low Pass Filter
LSB	Least Significant Bit
LUT	Look Up Table
LV	Low Voltage
MF	Multi-Function Macrocells
MSB	Most Significant Bit
MRT	Mean repair time
MUX	Multiplexer
NPR	Non-Volatile Memory Read/Write/Erase Protection
nRST	Reset
NVM	Non-Volatile Memory
OSC	Oscillator
OD	Open-Drain
OE	Output Enable
OTP	One time programmable
OUT	Output
PASS	Pass State
POR	Power-On-Reset
PD	Power-down
PGen	Pattern Generator
PP	Push-Pull

PWR	Power
P DLY	Programmable Delay
R/W	Read/Write
SM	Safety Mechanism
SFF	Safe Failure Fraction
SCL I2C	Clock Input
SDA I2C	Data Input/Output
SLA	Slave Address
SMT	With Schmitt Trigger
SV	nSET Value
TS	Temperature Sensor
Vref	Voltage Reference
WOSMT	Without Schmitt Trigger
WS	Wake and Sleep Controller

References

For related documents and software, please visit:

[Automotive GreenPAK™ Programmable Mixed-Signal ICs | Renesas](#)

- [1] [GreenPAK Go Configure Software Hub](#), Software Download and User Guide, Renesas Electronics
- [2] [GreenPAK Development Tools](#), GreenPAK Development Tools Webpage, Renesas Electronics
- [3] [GreenPAK Application Notes](#), GreenPAK Application Notes Webpage, Renesas Electronics
- [4] [SLG46855-A Datasheet](#)
- [5] [SLG46620-A Datasheet](#)
- [6] [SLG46625-A Datasheet](#)
- [7] [SLG46880-A Datasheet](#)
- [8] IEC 61508:2010 - Functional safety of electrical/electronic/programmable electronic safety-related Systems
- [9] ISO 26262: 2018 - Road vehicles – Functional safety
- [10] THERMAL SIMULATION FOR SLG46855-AP – [contact us to request the document](#)
- [11] SLG46855-AP_Reliability Report – [contact us to request the document](#)
- [12] THERMAL SIMULATION FOR PA84 – [contact us to request the document](#)
- [13] [SLG46857-A Datasheet](#)
- [14] [SLG47004-A Datasheet](#)
- [15] [SLG46827-A Datasheet](#)
- [16] [SLG46538-A Datasheet](#)

1. Introduction

This Application Note does not intend to replace the Datasheets of the GreenPAK products family. In case of contradictory interpretation between the products Datasheets and this document, the Datasheets take the precedence. The GreenPAK products that are addressed by this document are the following:

- SLG46620-AG
- SLG46855-AP
- SLG46625-AP
- SLG46880-AP
- SLG46857-AP
- SLG47004-AP
- SLG46827-AG
- SLG46538-AP

The GreenPAK products are suitable to be classified as class II HW element, based on ISO26262, part 8, clause 13.

1.1 Intended Audience

This document is written for integration engineers and/or functional safety managers involved in the design and/or development of a safety-related system who are considering the integration of the GreenPAK family products listed above in a IEC 61508 and/or ISO 26262 compliant system.

2. Parameters

See Table 1 for safety analysis parameters used in the calculation of failure rate.

Table 1: Failure Rate Parameters

Term	Description
λ	Probability in time of total amount of random failures (i.e. failure rate)
λ_{DU}	Probability in time of undetected dangerous random failure of a single channel
λ_{DD}	Probability in time of detected dangerous random failures of a single channel
λ_D	Probability in time of dangerous random hardware failures for each individual channel
λ_S	Probability in time of random Safe Faults

3. Assumptions

- The reference ambient temperature is assumed @ 55 °C.
- Clause 7.4.9.4, of [8], part k: “any additional information (for example repair times) that is necessary to allow the derivation of the mean repair time (MRT), see 3.6.22 of IEC 61508-4, following detection of a fault by the diagnostics”, is not applicable in this application note (AN) because the product is not repairable.
- Clause 7.4.9.4, of [8], part g: “any periodic proof test and/or maintenance requirements”, is not considered in this AN.
- Clause 7.4.9.4, of [8], part h: “for every failure mode in c) that is detected by diagnostics internal to the element, the diagnostic coverage derived according to Annex C”, is not applicable in this AN because neither of “intended functions” (IF), nor the related safety mechanisms (SM) are assumed to be configured into this product. Instead, the product can host SMs monitoring external IF.
- Clause 7.4.9.4, of [8], part i: “for every failure mode in c) that is detected by diagnostics internal to the element, the diagnostic test interval”, is not considered in this AN because the diagnostic test interval must be evaluated by the system integrator.
- Clause 7.4.9.4, of [8], part j: “the failure rate of the diagnostics, due to random hardware failures”, is not considered in this AN because diagnostics for the functions are not configured.
- Clause 7.4.9.4, of [8], part h: “for every failure mode in c) that is detected by diagnostics internal to the element, the diagnostic coverage derived according to Annex C”, is not considered in this AN because according to [9], diagnostic coverage (DC) is a percentage of the failure rate of the HW part that is detected or controlled by the implemented safety mechanism. Moreover, based on [9], the DC is the fraction of dangerous failures detected by automatic on-line diagnostic tests.
Neither of these definitions can be addressed in this AN as this product does not have any safety mechanism or diagnostic coverage.
- Clause 7.4.9.4, of [8], part l: “all information that is necessary to enable the derivation of the safe failure fraction (SFF) of the element as applied in the E/E/PE safety-related system, determined according to Annex C, including the classification as type A or type B according to 7.4.4”, is not considered in this AN because the application of the GreenPAK family device is not targeted as the integration of the whole Safety Instrumentation System (SIS). Instead, it implements part of the failure detection architecture, and it is used to monitor the failure on the system. There are not dangerous failures of the GreenPAK device for its intended application and SFF is equal to 100%.
- Clause 7.4.9.4, of [8], part m: “the hardware fault tolerance of the element”, is not considered in this AN because according to [8], the hardware fault tolerance is the ability of a system to continue operating without interruption when one or more of its components fail. The GreenPAK family product has no redundancy, and it stops operating when one component fails, therefore the hardware fault tolerance for this product is equal to zero.
- Mission Profile is defined for **motor control** based on IEC 62380.

4. Functional Description

The SLG46855-A provides a small, low power component for commonly used mixed-signal functions. The user creates their circuit design by programming the one time programmable (OTP) Non-Volatile Memory (NVM) to configure the wiring between the logic, the IO Pins, and the macrocells (i.e. MFC) of the product. This family of configurable products allows a wide variety of mixed-signal functions to be implemented within a single integrated circuit.

As an example, Figure 1 shows the system block diagram of one device of the GreenPAK family of products: SLG46855-A. A detailed description of specific Part Number usage and available functions are referred to in documents [1], [2], [3], [4], [5], [6], [7], [13], [14], [15] and [16].

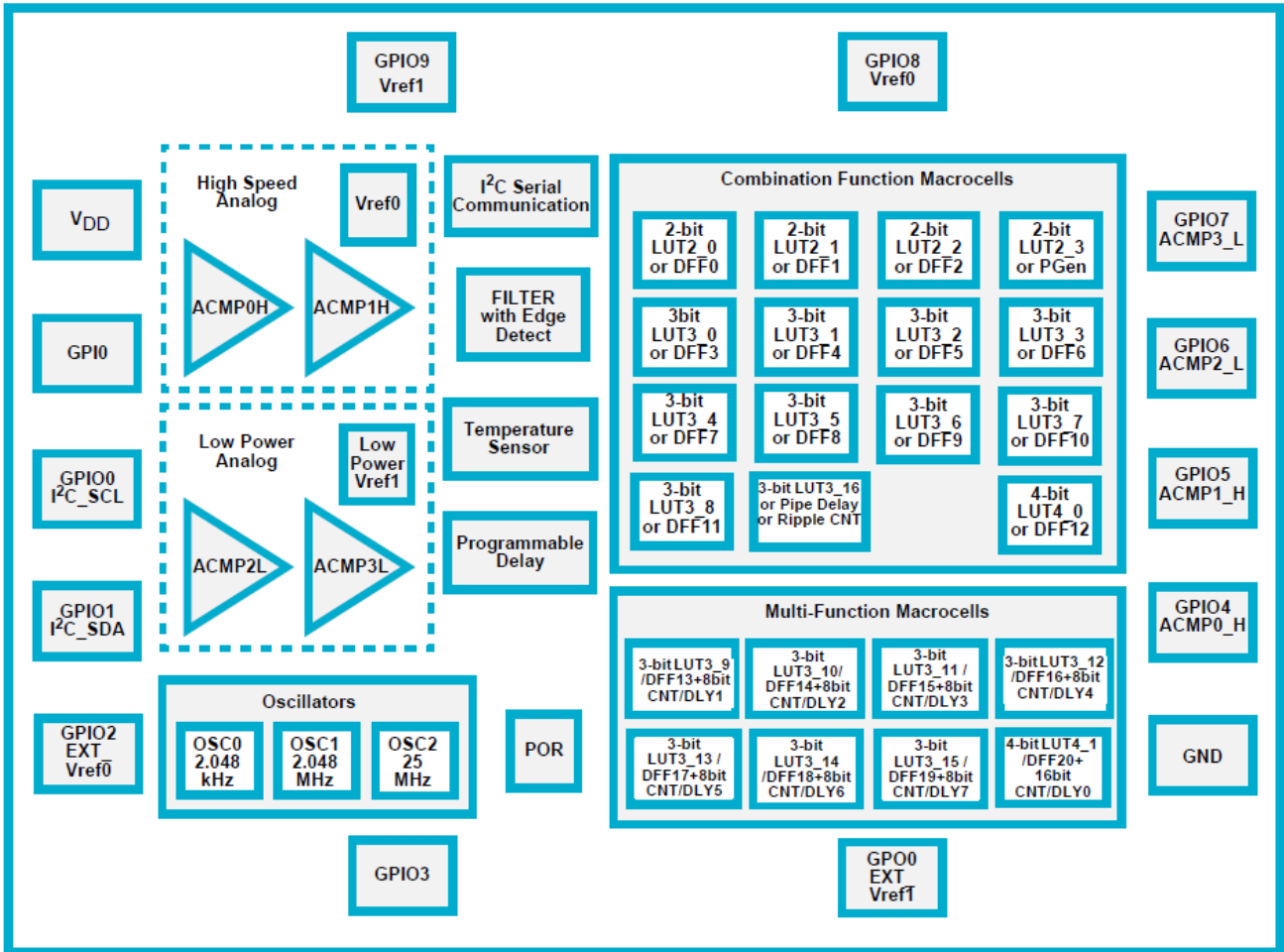

Figure 1: Block Diagram

5. Requirements for E/E/PE system Implementation Based on IEC 61508

According to [8] – part 2, clause 7.4.9.4, information detailed in sections 5.1, 5.2, 5.3, and 5.4 must be available for each safety-related element that is liable to random hardware failure.

5.1 Failure Mode Analysis

The failure modes of the element (in terms of the behavior of its outputs), due to random hardware failures, are defined as failures that result in a failure of the safety function and that are not detected by diagnostic tests internal to the element or are not detectable by diagnostics external to the element. Table 2 shows a non-exhaustive list of the potential failure modes of each functionality of GreenPAK. These failure modes are based on document [9] - Part 11. Depending on the functional safety requirements that are allocated at system level, the integrator of the GreenPAK IC must check the completeness and plausibility of the proposed failure modes before assigning the failure rate to each of them.

Table 2: Failure Modes of GreenPAK functions

Item	Failure Mode
GPIO (Digital I/O)	Stuck at
	Incorrect selection of input circuitry
	Floating
GPIO (Analog I/O)	Pull-up resistor Floating
	Pull-up resistor short to ground
	Pull-up resistor short to supply
	Incorrect selected pull-up/down resistor
	Pull-down resistor instead of pull-up
Analog comparator ACMPxH	Not triggering when expected
	Falsely triggering
	Output is stuck (i.e. high or low)
	Output is floating (i.e. open circuit)
	Output voltage oscillation
Analog comparator ACMPxL	Not triggering when expected
	Falsely triggering
	Output is stuck (i.e. high or low)
	Output is floating (i.e. open circuit)
	output voltage oscillation
Oscillator	Stuck-at
	Open
	Incorrect output signal swing

Determination of Failure In Time within the AEC-Q100 GreenPAK™ Family Automotive GreenPAK

Item	Failure Mode
	Incorrect Frequency
	Incorrect duty cycle
	Drift
	Jitter too high
I ² C	Function omission
	Function commission
	Function Timing
	Function value
Filter with Edge detect	Output is stuck (i.e. high or low)
	Output is floating
	Incorrect output dynamic range
	Incorrect attenuation of the output signal
	Incorrect settling time
	Drift affecting the output signal
	Oscillation affecting the output signal i.e. due to crosstalk, coupling or parasitic effects
	Spikes affecting the output (i.e. due to crosstalk, coupling or parasitic effects)
Temperature Sensor	Output is stuck (i.e. high or low)
	Output is floating
	Incorrect gain of the output voltage
	Incorrect offset on the output voltage
	Incorrect output dynamic range
	Incorrect input dynamic range
	Output voltage accuracy too low, including drift
	Output voltage affected by spikes
	Output voltage oscillation
	Settling time of the output voltage too low
POR	Output voltage higher than spec
	Output voltage lower than spec
	Output voltage affected by spikes
	Incorrect start-up time

Item	Failure Mode
	Output voltage accuracy too low
	Output voltage oscillation within expected range
	Fast oscillation outside the prescribed range
	Quiescent current too high
Combination function macrocell	Function omission
	Function commission
	Function Timing
	Function value
Multi-function macrocell	Function omission
	Function commission
	Function Timing
	Function value

5.2 Failure Rate Analysis

The failure rate of the IC is calculated with respect to its specified operating conditions. [Table 3](#) shows the reliability parameters that apply to each product of the GreenPAK Family and according to Siemens SN 29500 reliability standard. ¹

The common set of reliability parameters that applies to the GreenPAK products are as follows:

- Stress Profile dependence factor (π_W): 1
- Early failure dependence factor (π_F): 1
- Drift dependence factor (π_D): 1
- Voltage dependence factor (π_V): 1
- IC category: IC (ASIC)
- Non-erasable type: CMOS

¹ In this AN Siemens SN29500 standard and IEC 62380 are used as references. However, there are other qualification reports providing the failure rates according to JEDEC JESD85A. Based on the different reference standards, the outcome of analysis is different.

Table 3: Siemens SN29500 Reliability Tool Parameters

P/N	Number of Gates	Junction Elevated Temperature	Ref. λ @ 80 °C	Temperature Dependence Factor (πT)	Reference λ @ 55 °C
SLG46855-AP	30000	+10 °C	90FIT	0.5389	48.5FIT
SLG46857-AP	30000	+10 °C	90FIT	0.5389	48.5FIT
SLG46620-AG	43000	+10 °C	90FIT	0.5389	48.5FIT
SLG46625-AP	43000	+10 °C	90FIT	0.5389	48.5FIT
SLG46880-AP	53000	+10 °C	90FIT	0.5389	48.5FIT
SLG47004-AP	40000	+10 °C	90FIT	0.5389	48.5FIT
SLG46827-AG	21400	+10 °C	90FIT	0.5389	48.5FIT
SLG46538-AP	28400	+10 °C	90FIT	0.5389	48.5FIT

Additionally, [Table 5](#) shows the reliability parameters that apply to each product of the GreenPAK Family and according to IEC 62380 standard.

The common set of reliability parameters that applies to the GreenPAK products are as following:

- Category: IC, Silicon, MOS, ASIC
- Type: Electrically Programmable (interconnected macrocells array)
- Package: Refer to the datasheet of the products
- Substrate: Epoxy Glass (FR4,G-10)
- Component: Epoxy (Plastic Pack)
- PCB Mount Type: Surface Mount
- Package Status: Packaged or Glob Top

Surface Mount Package: Peripheral Connections

Other input parameters are reported in [Table 4](#):

Table 4: IEC 62380 input Tool Parameters

P/N	Number of Transistors	πI	$\lambda 1$	$\lambda 2$	αS	αC	πa
SLG46620-AG	215 K	1	2.0 E-5	34	16.0 ppm/°C	21.5 ppm/°C	1.05
SLG46855-AP	150 K	1	2.0 E-5	34	16.0 ppm/°C	21.5 ppm/°C	1.05
SLG46857-AP	150 K	1	2.0 E-5	34	16.0 ppm/°C	21.5 ppm/°C	1.05
SLG46625-AP	215 K	1	2.0 E-5	34	16.0 ppm/°C	21.5 ppm/°C	1.05
SLG46880-AP	265 K	1	2.0 E-5	34	16.0 ppm/°C	21.5 ppm/°C	1.05
SLG47004-AP	200K	1	2.0 E-5	34	16.0 ppm/°C	21.5 ppm/°C	1.05
SLG46827-AG	107K	1	2.0 E-5	34	16.0 ppm/°C	21.5 ppm/°C	1.05
SLG46538-AP	142K	1	2.0 E-5	34	16.0 ppm/°C	21.5 ppm/°C	1.05

Finally, the baseline failure rate of the GreenPAK products based on IEC 62380 are reported in [Table 5](#):

Table 5: IEC 62380 output Tool Parameters (Baseline Failure Rates)

P/N	λ package	λ EOS *	λ die	λ Tot
SLG46620-AG	15.99	20	5.54	41.53
SLG46855-AP	6.88	20	7.26	34.14
SLG46857-AP	6.95	20	7.76	34.71
SLG46625-AP	8.50	20	4.63	33.13
SLG46880-AP	16.85	20	4.34	41.19
SLG47004-AP	11.34	20	5.53	36.87
SLG46827-AG	16.49	20	7.20	43.69
SLG46538-AP	12.99	20	11.74	44.73

*Electrical environment: according Renesas has been chosen Civilian avionics, which is a conservative approach as GreenPAK includes overvoltage protection, current limitation and reverse polarity protection circuitries.

[Table 6](#) details the split of failure rates between the IC functions. In case of using a fraction ² of an MFC resource, the split of failure rates between the N-bit LUT and CNT/DLY is 1/8 – 7/8.

Note:

For the λ die calculation, Theoretical Absolute Maximum Ratings values for average current have been used following a conservative approach

² Fraction is a ratio of each micro block size over the total amount of area of the die.

Determination of Failure In Time within the AEC-Q100 GreenPAK™ Family Automotive GreenPAK

Table 6: Failure Rates of GreenPAK Functions

Failure Modes	SLG46855-AP & SLG46857-AP	SLG46880-AP	SLG46620-AG & SLG46625-AP	SLG47004-AP	SLG46827-AG	SLG46538-AP
VDD	1.4%	2.11%	0.73%	NA	1.19%	0.61%
VDD2	NA	0.71%	NA	NA	0.8%	1.03%
VDDA	NA	NA	NA	0.49%	NA	NA
VDD (Digital)	NA	NA	NA	0.49%	NA	NA
GND	0.0%	0.28%	1.28%	NA	0.0%	0.70%
GND2	NA	1.14%	NA	NA	NA	NA
AGND	NA	NA	NA	0.0%	NA	NA
GND (Digital)	NA	NA	NA	0.0%	NA	NA
GPI	NA	NA	1.08%	NA	NA	NA
GPO0	2.6%	0.79%	NA	NA	0.8%	NA
GPO1	NA	0.94%	NA	NA	NA	NA
GPO2	NA	0.94%	NA	NA	NA	NA
GPO3	NA	0.94%	NA	NA	NA	NA
GPO4	NA	0.94%	NA	NA	NA	NA
GPO5	NA	0.79%	NA	NA	NA	NA
GPO6	NA	0.79%	NA	NA	NA	NA
GPO7	NA	0.80%	NA	NA	NA	NA
GPI0	1.1%	0.47%	NA	0.38%	0.8%	0.89%
GPI1	NA	0.72%	NA	NA	NA	NA
GPI2/SDA	NA	0.66%	NA	NA	NA	NA
GPI3/SCL	NA	0.66%	NA	NA	NA	NA
GPI4	NA	0.94%	NA	NA	NA	NA
GPI5	NA	0.72%	NA	NA	NA	NA
GPI6	NA	0.71%	NA	NA	NA	NA
GPI7	NA	0.71%	NA	NA	NA	NA
GPIO1	NA	0.88%	NA	0.49%	NA	1.15%
GPIO0	NA	0.88%	NA	0.49%	NA	NA

Determination of Failure In Time within the AEC-Q100 GreenPAK™ Family Automotive GreenPAK

Failure Modes	SLG46855-AP & SLG46857-AP	SLG46880-AP	SLG46620-AG & SLG46625-AP	SLG47004-AP	SLG46827-AG	SLG46538-AP
GPIO0/SCL	1.4%	NA	NA	NA	0.8%	NA
GPIO1/SDA	1.4%	NA	NA	NA	0.8%	NA
GPIO2	1.4%	0.88%	NA	0.49%	NA	1.03%
GPIO3	1.4%	1.03%	NA	0.49%	NA	1.16%
GPIO4	2.7%	1.03%	NA	0.49%	NA	1.03%
GPIO5	1.4%	1.03%	NA	0.49%	NA	1.16%
GPIO6	1.4%	1.11%	NA	0.49%	NA	NA
GPIO6/SCL	NA	NA	NA	NA	NA	1.03
GPIO7	1.4%	1.03%	NA	NA	NA	NA
GPIO7/SDA	NA	NA	NA	NA	NA	1.03
GPIO8	1.4%	1.02%	NA	NA	NA	2.01%
GPIO9	1.4%	0.88%	NA	NA	NA	1.87%
GPIO10	NA	0.88%	NA	NA	NA	1.16%
GPIO11	NA	0.88%	NA	NA	NA	NA
GPIO12	NA	NA	NA	NA	NA	1.03%
GPIO13	NA	NA	NA	NA	NA	1.16%
GPIO14	NA	NA	NA	NA	NA	1.03%
GPIO15	NA	NA	NA	NA	NA	1.16%
GPIO16	NA	NA	NA	NA	NA	1.16%
GPIO17	NA	NA	NA	NA	NA	1.03%
GPIO	NA	NA	1.23%	NA	0.8%	NA
GPIO	NA	NA	1.23%	NA	0.8%	NA
GPIO	NA	NA	1.23%	NA	0.8%	NA
GPIO	NA	NA	1.23%	NA	0.8%	NA
GPIO	NA	NA	1.23%	NA	0.8%	NA
GPIO	NA	NA	1.23%	NA	0.8%	NA
GPIO	NA	NA	1.23%	NA	0.8%	NA

Determination of Failure In Time within the AEC-Q100 GreenPAK™ Family Automotive GreenPAK

Failure Modes	SLG46855-AP & SLG46857-AP	SLG46880-AP	SLG46620-AG & SLG46625-AP	SLG47004-AP	SLG46827-AG	SLG46538-AP
GPIO	NA	NA	1.23%	NA	0.8%	NA
GPIO	NA	NA	1.23%	NA	0.8%	NA
GPIO	NA	NA	1.23%	NA	0.8%	NA
GPIO	NA	NA	1.23%	NA	0.8%	NA
GPIO	NA	NA	1.23%	NA	0.8%	NA
GPIO	NA	NA	1.23%	NA	0.8%	NA
GPIO	NA	NA	1.23%	NA	NA	NA
GPIO	NA	NA	1.23%	NA	NA	NA
GPIO	NA	NA	1.23%	NA	NA	NA
OA0-	NA	NA	NA	0.44%	NA	NA
OA0+	NA	NA	NA	0.44%	NA	NA
OA0_OUT	NA	NA	NA	0.44%	NA	NA
OA1-	NA	NA	NA	0.44%	NA	NA
OA1+	NA	NA	NA	0.44%	NA	NA
OA1_OUT	NA	NA	NA	0.44%	NA	NA
RH0_A	NA	NA	NA	0.44%	NA	NA
RH0_B	NA	NA	NA	0.44%	NA	NA
RH1_A	NA	NA	NA	0.44%	NA	NA
RH1_B	NA	NA	NA	0.44%	NA	NA
OPAMP0	NA	NA	NA	12.92%	NA	NA
OPAMP1	NA	NA	NA	12.92%	NA	NA
OPAMP INTERNAL	NA	NA	NA	12.92%	NA	NA
Digital Rheostat0	NA	NA	NA	8.92%	NA	NA
Digital Rheostat1	NA	NA	NA	8.92%	NA	NA
Analog SW0	NA	NA	NA	3.10%	NA	NA
Analog SW1	NA	NA	NA	1.65%	NA	NA
Chopper ACMP	NA	NA	NA	2.26%	NA	NA
ACMP0	NA	NA	1.52%	NA	NA	3.16%

Determination of Failure In Time within the AEC-Q100 GreenPAK™ Family Automotive GreenPAK

Failure Modes	SLG46855-AP & SLG46857-AP	SLG46880-AP	SLG46620-AG & SLG46625-AP	SLG47004-AP	SLG46827-AG	SLG46538-AP
ACMP1	NA	NA	1.52%	NA	NA	3.15%
ACMP2	NA	NA	1.52%	NA	NA	3.14%
ACMP3	NA	NA	1.52%	NA	NA	3.15%
ACMP4	NA	NA	1.52%	NA	NA	NA
ACMP5	NA	NA	1.52%	NA	NA	NA
ACMP0H	6.9%	1.97%	NA	NA	2.22%	NA
ACMP1H	6.9%	1.91%	NA	NA	2.22%	NA
ACMP0L	NA	NA	NA	1.28%	NA	NA
ACMP1L	NA	NA	NA	1.28%	NA	NA
ACMP2L	3.8%	1.49%	NA	NA	1.85%	NA
ACMP3L	3.8%	1.49%	NA	NA	1.85%	NA
FILTER/EDGEDET	0.3%	0.19%	0.0%	0.1%	0.86%	NA
FILTER0/EDGEDET0	NA	NA	NA	NA	NA	0.45%
FILTER1/EDGEDET1	NA	NA	NA	NA	NA	0.45%
ADC (DAC0, DAC1)	NA	NA	12.30%	NA	NA	NA
PGA	NA	NA	9.21%	NA	NA	NA
DFF/LATCH0 w/ resetb or setb	NA	NA	0.05%	NA	NA	NA
DFF/LATCH1 w/ resetb or setb	NA	NA	0.05%	NA	NA	NA
DFF/LATCH2 w/ resetb or setb	NA	NA	0.05%	NA	NA	NA
DFF/LATCH3	NA	NA	0.04%	NA	NA	NA
DFF/LATCH4	NA	NA	0.04%	NA	NA	NA
DFF/LATCH5	NA	NA	0.04%	NA	NA	NA
DFF/LATCH6 w/ resetb or setb	NA	NA	0.05%	NA	NA	NA
DFF/LATCH7 w/ resetb or setb	NA	NA	0.05%	NA	NA	NA
DFF/LATCH8 w/ resetb or setb	NA	NA	0.05%	NA	NA	NA

Determination of Failure In Time within the AEC-Q100 GreenPAK™ Family Automotive GreenPAK

Failure Modes	SLG46855-AP & SLG46857-AP	SLG46880-AP	SLG46620-AG & SLG46625-AP	SLG47004-AP	SLG46827-AG	SLG46538-AP
DFF/LATCH9	NA	NA	0.04%	NA	NA	NA
DFF/LATCH10	NA	NA	0.04%	NA	NA	NA
DFF/LATCH11	NA	NA	0.04%	NA	NA	NA
2-bit LUT0/DFF/LATCH0	0.3%	0.21%	NA	0.09%	NA	0.40%
2-bit LUT1/DFF/LATCH1	0.3%	NA	NA	0.09%	NA	0.40%
2-bit LUT2/DFF/LATCH2	0.3%	NA	NA	0.09%	NA	0.40%
2-bit LUT3/PGEN	0.6%	NA	NA	0.19%	NA	0.65%
2-bit LUT1/PGEN	NA	0.31%	NA	NA	NA	NA
2-bit LUT0	NA	NA	0.02%	NA	NA	NA
2-bit LUT1	NA	NA	0.02%	NA	NA	NA
2-bit LUT2	NA	NA	0.02%	NA	NA	NA
2-bit LUT3	NA	NA	0.02%	NA	NA	NA
2-bit LUT4	NA	NA	0.02%	NA	NA	NA
2-bit LUT5	NA	NA	0.02%	NA	NA	NA
2-bit LUT6	NA	NA	0.02%	NA	NA	NA
2-bit LUT7	NA	NA	0.02%	NA	NA	NA
3-bit LUT0/DFF/LATCH1	NA	0.32%	NA	NA	NA	NA
3-bit LUT0/DFF/LATCH3	0.4%	NA	NA	0.13%	NA	0.61%
3-bit LUT1/DFF/LATCH2	NA	0.32%	NA	NA	NA	NA
3-bit LUT1/DFF/LATCH4	0.4%	NA	NA	0.13%	NA	0.60%
3-bit LUT2/DFF/LATCH3	NA	0.31%	NA	NA	NA	NA
3-bit LUT2/DFF/LATCH5	0.4%	NA	NA	0.13%	NA	0.60%
3-bit LUT3/DFF/LATCH4	NA	0.31%	NA	NA	NA	NA
3-bit LUT3/DFF/LATCH6	0.4%	NA	NA	0.13%	NA	0.60%

Determination of Failure In Time within the AEC-Q100 GreenPAK™ Family Automotive GreenPAK

Failure Modes	SLG46855-AP & SLG46857-AP	SLG46880-AP	SLG46620-AG & SLG46625-AP	SLG47004-AP	SLG46827-AG	SLG46538-AP
3-bit LUT4/DFF/LATCH7	0.4%	NA	NA	0.13%	NA	0.60%
3-bit LUT5/DFF/LATCH8	0.4%	NA	NA	0.13%	NA	NA
3-bit LUT6/DFF/LATCH9	0.4%	NA	NA	0.13%	NA	NA
3-bit LUT7/DFF/LATCH10	0.4%	NA	NA	NA	NA	NA
3-bit LUT8/DFF/LATCH11	0.4%	NA	NA	NA	NA	NA
3-bit LUT 4/8-bit CNT1/DLY1	NA	0.83%	NA	NA	NA	NA
3-bit LUT 5/8-bit CNT2/DLY2	NA	0.83%	NA	NA	NA	1.30%
3-bit LUT 6/8-bit CNT3/DLY3	NA	0.83%	NA	NA	NA	1.30%
3-bit LUT 7/8-bit CNT4/DLY4	NA	0.83%	NA	NA	NA	1.34%
3-bit LUT 8/8-bit CNT5/DLY5	NA	NA	NA	NA	NA	1.30%
3-bit LUT 9/8-bit CNT6/DLY6	NA	NA	NA	NA	NA	1.34%
3-bit LUT 10/ Pipe Delay	NA	NA	NA	NA	NA	0.78%
3-bit LUT 8/Pipe Delay/Ripple Counter	NA	0.51%	NA	NA	NA	NA
3-bit LUT13/Pipe Delay/Ripple Counter	NA	NA	NA	0.28%	NA	NA
3-bit LUT16/Pipe Delay/Ripple Counter	0.9%	NA	NA	NA	NA	NA
3-bit LUT0	NA	NA	0.03%	NA	NA	NA
3-bit LUT1	NA	NA	0.03%	NA	NA	NA
3-bit LUT2	NA	NA	0.03%	NA	NA	NA
3-bit LUT3	NA	NA	0.03%	NA	NA	NA
3-bit LUT4	NA	NA	0.03%	NA	NA	NA
3-bit LUT5	NA	NA	0.03%	NA	NA	NA
3-bit LUT6	NA	NA	0.03%	NA	NA	NA

Determination of Failure In Time within the AEC-Q100 GreenPAK™ Family Automotive GreenPAK

Failure Modes	SLG46855-AP & SLG46857-AP	SLG46880-AP	SLG46620-AG & SLG46625-AP	SLG47004-AP	SLG46827-AG	SLG46538-AP
3-bit LUT7	NA	NA	0.03%	NA	NA	NA
3-bit LUT8	NA	NA	0.03%	NA	NA	NA
3-bit LUT9	NA	NA	0.03%	NA	NA	NA
3-bit LUT10	NA	NA	0.03%	NA	NA	NA
3-bit LUT11	NA	NA	0.03%	NA	NA	NA
3-bit LUT12	NA	NA	0.03%	NA	NA	NA
3-bit LUT13	NA	NA	0.03%	NA	NA	NA
3-bit LUT14	NA	NA	0.03%	NA	NA	NA
3-bit LUT15	NA	NA	0.03%	NA	NA	NA
2-bit, 3-bit LUT / DFF/LATCH, PGEN, Pipe delay (Combination Function Macrocells)	NA	NA	NA	NA	1.94%	NA
4-bit LUT0/PGEN	NA	NA	0.25%	NA	NA	NA
4-bit LUT1	NA	NA	0.05%	NA	NA	NA
4-bit LUT 0, WS Ctrl, 16-bit CNT0/DLY0/FSM0	NA	1.24%	NA	NA	NA	2.53%
4-bit LUT 1, 16-bit CNT1/DLY1/FSM1	NA	NA	NA	NA	NA	2.52%
4-bit LUT0/ DFF/LATCH10	NA	NA	NA	0.19%	NA	NA
4-bit LUT0/ DFF/LATCH12	0.7%	NA	NA	NA	NA	NA
14-bit CNT0/DLY0/WS Ctrl	NA	NA	1.61%	NA	NA	NA
14-bit CNT1/DLY1	NA	NA	1.40%	NA	NA	NA
14-bit CNT2/DLY2/FSM0	NA	NA	1.53%	NA	NA	NA
14-bit CNT3/DLY3	NA	NA	1.40%	NA	NA	NA
8-bit CNT4/DLY4/FSM1	NA	NA	1.15%	NA	NA	NA
8-bit CNT5/DLY5	NA	NA	0.98%	NA	NA	NA
8-bit CNT6/DLY6	NA	NA	0.98%	NA	NA	NA

Determination of Failure In Time within the AEC-Q100 GreenPAK™ Family Automotive GreenPAK

Failure Modes	SLG46855-AP & SLG46857-AP	SLG46880-AP	SLG46620-AG & SLG46625-AP	SLG47004-AP	SLG46827-AG	SLG46538-AP
8-bit CNT7/DLY7	NA	NA	0.98%	NA	NA	NA
8-bit CNT7/DLY8	NA	NA	0.98%	NA	NA	NA
8-bit CNT7/DLY9	NA	NA	0.98%	NA	NA	NA
MF0 (4-bit LUT0, DFF/LATCH9, WS Ctrl, 16-bit CNT0/DLY0/FSM0)	NA	NA	NA	NA	1.59%	NA
MF0 (4-bit LUT1, DFF/LATCH17, WS Ctrl, 16-bit CNT0/DLY0/FSM0)	NA	NA	NA	0.91%	NA	NA
MF0 (4-bit LUT1, DFF/LATCH20, WS Ctrl, 16-bit CNT0/DLY0/FSM0)	2.7%	NA	NA	NA	NA	NA
MF1 (3-bit LUT7, DFF/LATCH11, 8-bit CNT1/DLY1)	NA	NA	NA	0.60%	1.33%	NA
MF2 (3-bit LUT8, DFF/LATCH11, 8-bit CNT2/DLY2)	NA	NA	NA	NA	1.33%	NA
MF1 (3-bit LUT9, DFF/LATCH13, 8-bit CNT1/DLY1)	1.8%	NA	NA	NA	NA	NA
MF2 (3-bit LUT8, DFF/LATCH12, 8-bit CNT2/DLY2)	NA	NA	NA	0.60%	NA	NA
MF2 (3-bit LUT10, DFF/LATCH14, 8-bit CNT2/DLY2)	1.8%	NA	NA	NA	NA	NA
MF3 (3-bit LUT9, DFF/LATCH12, 8-bit CNT3/DLY3)	NA	NA	NA	NA	1.33%	NA
MF3 (3-bit LUT9, DFF/LATCH13, 8-bit CNT3/DLY3)	NA	NA	NA	0.60%	NA	NA
MF3 (3-bit LUT11, DFF/LATCH15, 8-bit CNT3/DLY3)	1.8%	NA	NA	NA	NA	NA
MF4 (3-bit LUT10, DFF/LATCH13, 8-bit CNT4/DLY4)	NA	NA	NA	NA	1.33%	NA

Determination of Failure In Time within the AEC-Q100 GreenPAK™ Family Automotive GreenPAK

Failure Modes	SLG46855-AP & SLG46857-AP	SLG46880-AP	SLG46620-AG & SLG46625-AP	SLG47004-AP	SLG46827-AG	SLG46538-AP
MF4 (3-bit LUT10, DFF/LATCH14, 8-bit CNT4/DLY4)	NA	NA	NA	0.60%	NA	NA
MF4 (3-bit LUT12, DFF/LATCH16, 8-bit CNT4/DLY4)	1.8%	NA	NA	NA	NA	NA
MF5 (3-bit LUT11, DFF/LATCH14, 8-bit CNT5/DLY5)	NA	NA	NA	NA	1.33%	NA
MF5 (3-bit LUT11, DFF/LATCH15, 8-bit CNT5/DLY5)	NA	NA	NA	0.60%	NA	NA
MF5 (3-bit LUT13, DFF/LATCH17, 8-bit CNT5/DLY5)	1.8%	NA	NA	NA	NA	NA
MF6 (3-bit LUT12, DFF/LATCH15, 8-bit CNT6/DLY6)	NA	NA	NA	NA	1.33%	NA
MF6 (3-bit LUT12, DFF/LATCH16, 8-bit CNT6/DLY6)	NA	NA	NA	0.60%	NA	NA
MF6 (3-bit LUT14, DFF/LATCH18, 8-bit CNT6/DLY6)	1.8%	NA	NA	NA	NA	NA
MF7 (3-bit LUT13, DFF/LATCH16, 8-bit CNT7/DLY7)	NA	NA	NA	NA	1.33%	NA
MF7 (3-bit LUT15, DFF/LATCH19, 8-bit CNT7/DLY7)	1.8%	NA	NA	NA	NA	NA
ASM State 0	NA	5.96%	NA	NA	NA	NA
ASM Dynamic Memory (DM0_0, DM0_1, DM1_0, DM1_1)	NA	13.0%	NA	NA	NA	NA
ASM Special (F 1, state independent comp.)	NA	7.79%	NA	NA	NA	NA
P DLY	0.8%	0.21%	NA	0.27%	NA	0.52%
P DLY0	NA	NA	0.45%	NA	NA	NA
P DLY1	NA	NA	0.45%	NA	NA	NA
VREF0	2.0%	1.06%	0.96%	0.69%	3.60%	3.27%

Determination of Failure In Time within the AEC-Q100 GreenPAK™ Family Automotive GreenPAK

Failure Modes	SLG46855-AP & SLG46857-AP	SLG46880-AP	SLG46620-AG & SLG46625-AP	SLG47004-AP	SLG46827-AG	SLG46538-AP
VREF1	2.0%	0.87%	0.96%	0.69%	3.60%	3.27%
BG	NA	4.08%	4.53%	NA	5.14%	NA
POR(a)	8.10%	17.17%	5.69%	2.72%	13.07%	18.57%
PWR DET	NA	NA	5.92%	NA	NA	NA
OSC0	6.6%	2.74%	NA	2.21%	3.54%	5.29%
OSC1	3.8%	1.47%	NA	1.30%	2.31%	1.66%
OSC2	2.3%	0.76%	NA	0.75%	1.38%	NA
Crystal OSC	NA	0.04%	NA	NA	NA	NA
I2C	10.8%	2.49%	NA	3.77%	see NVM top (I2C & NVM Ctrl)	5.91%
TEMP SENSOR	0.3%	0.17%	NA	0.09%	0.93%	0.15%
Pipe Delay0	NA	NA	0.32%	NA	NA	NA
Pipe Delay1	NA	NA	0.32%	NA	NA	NA
SDA	NA	NA	NA	0.47%	NA	NA
SCL	NA	NA	NA	0.47%	NA	NA
SPI	NA	NA	1.19%	NA	NA	NA
SPI_SDIO (GPIO)	NA	NA	2.37%	NA	NA	NA
LFOSC	NA	NA	2.03%	NA	NA	NA
RCOSC	NA	NA	3.42%	NA	NA	NA
RINGOSC	NA	NA	0.62%	NA	NA	NA
DCM0/PWM0	NA	NA	1.30%	NA	NA	NA
DCM1/PWM1	NA	NA	1.30%	NA	NA	NA
DCM2/PWM2	NA	NA	1.30%	NA	NA	NA
INV0	NA	NA	0.00%	NA	NA	0.14%
INV1/	NA	NA	0.00%	NA	NA	NA
HD BUFFER	NA	NA	NA	1.60%	NA	NA
VREF OPAMP0	NA	NA	NA	0.69%	NA	NA
VREF OPAMP1	NA	NA	NA	0.69%	NA	NA

Failure Modes	SLG46855-AP & SLG46857-AP	SLG46880-AP	SLG46620-AG & SLG46625-AP	SLG47004-AP	SLG46827-AG	SLG46538-AP
EEPROM	NA	NA	NA	1.78%	NA	NA
MTP	NA	NA	NA	NA	17.10%	NA
NVM top (I2C & NVM Ctrl) + in system debug	NA	NA	NA	NA	11.90%	NA
ASM	NA	NA	NA	NA	NA	8.02%
Total	100%	100%	100%	100%	100%	100%

Note: 2k register + matrix areas are considered divided and widespread in all function blocks areas except for PINs. Decoupling cap, and Routing + DRC distance have not been considered in Table 6 since they are included in the CCF analysis.

5.2.1. Consideration of Common Cause Failure

When considering the failure rate of each of the configured GreenPAK functions, it results in a fraction (K) of the overall failure rate. This means that the fraction of failure rate of the unused GreenPAK functions is $1 - K$.

Note that not all failures of the unused GreenPAK functions are neutral, as a minor fraction of them (i.e. Y) can be due to Common Cause Failure (CCF). It is recommended to take them into account by adding a $Y \times (1 - K)$ contribution to the fraction of failure rate K for the configured GreenPAK functions. The fraction of failure rate of the configured GreenPAK functions are equal to $K + Y \times (1 - K)$.

Factor K is defined by the application, while factor Y can be selected in the range of 20%³.

5.2.2. Propagation delay and response times

Typical Propagations Delays and response times are listed in data sheet of GreenPAK family products [3], [4], [5], [6], [7], [13], [14], [15] and [16].

5.3 Environmental Range

Any limits on the environment of the element must be observed to maintain the validity of the estimated rates of failure due to random hardware failures.

For the SLG46855-AP device, the thermal simulation is reported in [10]. In this simulation report, the materials are assumed to be in perfect adhesion and behave isotropically, uniform power is applied at the die surface.

5.4 Lifetime Reliability Reports

It is highly recommended to compare the required mission profile of the GreenPAK environmental stressors against the qualification plan and report, as based on the AEC-Q100 standard. The assumptions of the failure rates due to random hardware failures listed in section 3 rely on the environmental stressors profile that is supported by the reliability qualifications of the IC. For more details refer to [11].

³ Factor Y depends on the customer and the CCF on its application. Renesas recommends to use the range of 20% to 25%.

6. Case Study: Example of Failure Rate Analysis

6.1 General Analysis

This case study provides the integrators with a guideline on understanding how the failure rate of GreenPAK products must be considered in the user application.

Note: the failures of the GreenPAK family of products are considered as dual point failures at the system level, because GreenPAK family products are used as SMs for the integrated system's intended functionalities.

Figure 2 shows the SLG46855-AP configuration schematic with all the output signals of the ASIC which have contribution in the calculation of failure rate analysis in the integrated system.

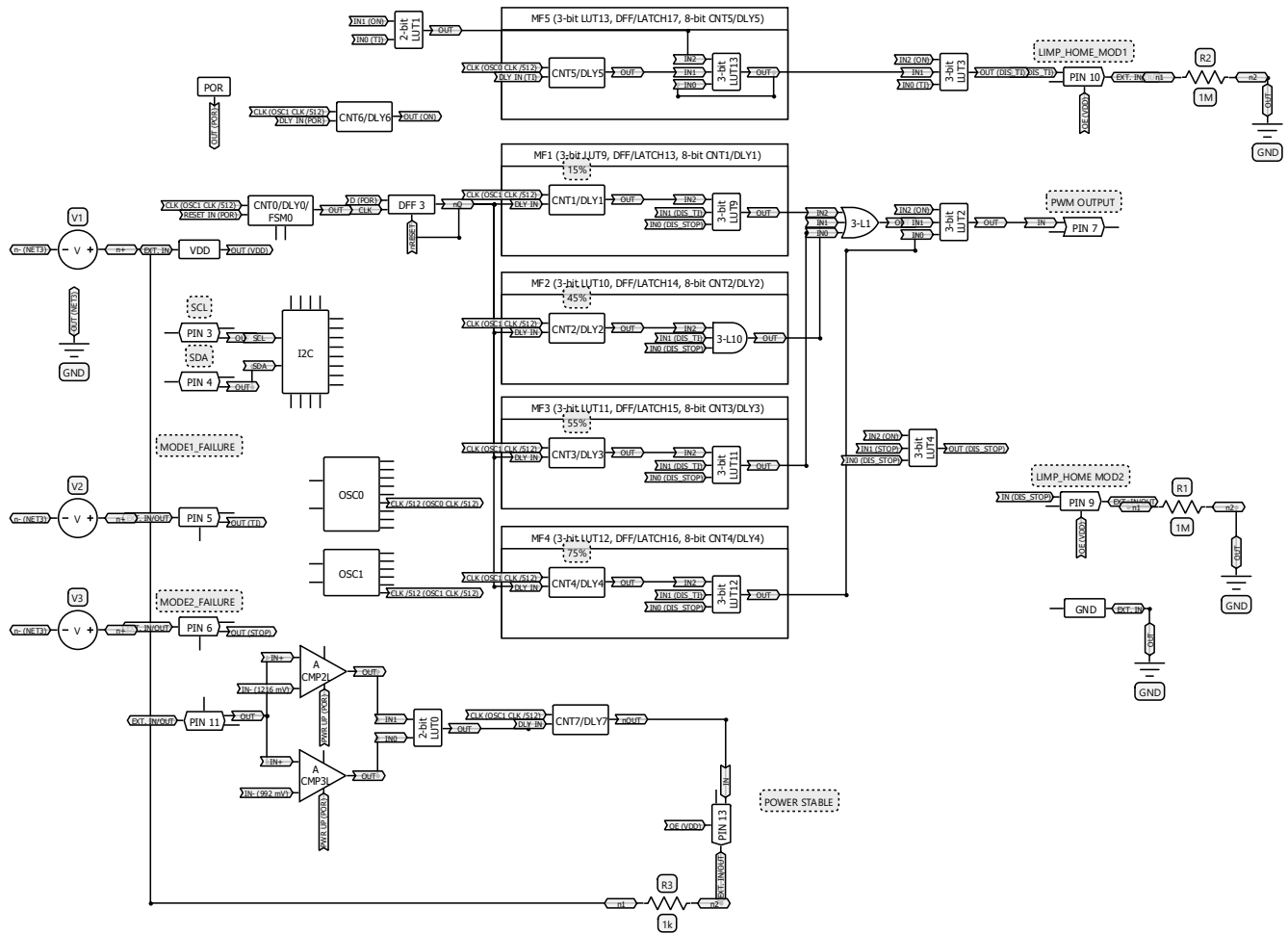

Figure 2: SLG46855-AP Configuration

As an example, the case study of customer Functional Safety Requirement (FSR1) with assigned Automotive Safety Integrity Level (ASIL) is allocated to the SLG46855-AP as the following: When a TI failure is activated through Pin 5 "MODE1_FAILURE", the IC shall send a PWM at 120 Hz (DC 15%) using the Pin 7 "PWM_OUTPUT" and disable the TI using Pin 10 "LIMP_HOME_MOD1" within 200ms (ASIL C).

Starting from this functional safety requirement, all failures violating FSR1 must be investigated and relevant to the safety analysis started. The system integrator must define the safety path derived from FSR1 with all safety related components in which their failures are contributing to the violation of functional safety requirement. See

Table 7 all safety related functions of the SLG46855-AP which can violate FSR1. It also lists the percentage of failure rates derived from Table 6 and the failure rates of each function @ 55 °C according to Table 3.

Table 7: Failure rate analysis of FSR1

Failure Modes	Failure Rate Percentage	Failure Rate @ 55 °C
PIN1 (VDD)	1.4%	0.68FIT
PIN2 (GPIO)	1.1%	0.53FIT
PIN5 (GPIO2)	1.4%	0.68FIT
PIN6 (GPIO3)	1.4%	0.68FIT
PIN7 (GPO0)	2.6%	1.26FIT
PIN8 (GND)	0.0%	0.00FIT
PIN10 (GPIO5)	1.4%	0.68FIT
PIN11 (GPIO6)	1.4%	0.68FIT
PIN13 (GPIO8)	1.4%	0.68FIT
ACMP2L	3.75%	1.82FIT
ACMP3L	3.75%	1.82FIT
2-bit LUT1 / DFF/LATCH1	0.3%	0.15FIT
2-bit LUT1 / DFF/LATCH1	0.3%	0.15FIT
3-bit LUT2 / DFF/LATCH5	0.4%	0.19FIT
3-bit LUT3 / DFF/LATCH6	0.4%	0.19FIT
CNT0/DLY0	2.7%	1.31FIT
MF1 (3-bit LUT9, DFF/LATCH13, 8-bit CNT1/DLY1)	1.8%	0.87FIT
MF5 (3-bit LUT13, DFF/LATCH17, 8-bit CNT5/DLY5)	1.8%	0.87FIT
CNT6/DLY6	1.8%	0.87FIT
CNT7/DLY7	1.8%	0.87FIT
POR	8.1%	3.93FIT
OSC0	6.6%	3.20FIT
OSC1	3.8%	1.84FIT
Total	49.4%	23.95FIT

1. I2C connection is not assumed to the system except one time for programming operation. The failure rate of this function is not considered.
If an application is connected to I2C, safety analysis must be done on the function.
2. Power supply monitoring circuit has the same VDD as all ASIC.
3. Failure rate of CNT0/DLY0 is 1/8 of MF0 (4-bit LUT1, DFF/LATCH20, WS Ctrl, 16-bit CNT0/DLY0/FSM0).
4. Failure rate of CNT6/DLY6 is 1/8 of MF6 (3-bit LUT14, DFF/LATCH18, 8-bit CNT6/DLY6).

Failure rate of CNT7/DLY7 is 1/8 of MF7 (3-bit LUT15, DFF/LATCH19, 8-bit CNT7/DLY7). Based on the user's reference standard (for example, SN 29500) and the essential parameters requested by that standard (for example, reference ambient temperature), the baseline failure rate of the ASIC can be achieved. According to

Table 7 for FSR1, a 49.4% baseline failure rate is estimated for this output signal as dual point failures, contributing to its integrated system failure rate analysis.

To obtain a more conservative approach in the application safety analysis, it is recommended to include the CCF failure rate in the application by defining parameters such as fraction K and fraction Y. Based on

Table 7,

the total failure rate percentage of the GreenPAK application for fraction K is reported as 49.4%, and assuming fraction Y is equal to 20%, the total failure rate of the GreenPAK including CCF is reported in Table 8.

Table 8: Total Failure Rate Including CCF

K	Y	$Y + K \times (1 - Y)$	Failure Rate @ 55 °C
49.4%	20%	59.52%	28.87FIT

6.2 Detailed Analysis

The failure rate analysis of one functional safety requirement in the integrated system level gives a general approach of the total percentage of FIT rate. It is also possible to have a more detailed analysis of a specific function.

As an example, the same FSR1 is used as in section 6.1 where one of the output signals of the system is “PIN10” that is responsible for “LIMP_HOME_MOD1”. According to the Datasheet document [1], PIN10 (GPIO5) is composed of six circuitries that implement the following functions (see Figure 3 for details):

- One Digital input,
- One Analog Input/Output (with internal pull-up/down resistors)
- Four different instances of Digital output (two with open drain and two with push-pull output).

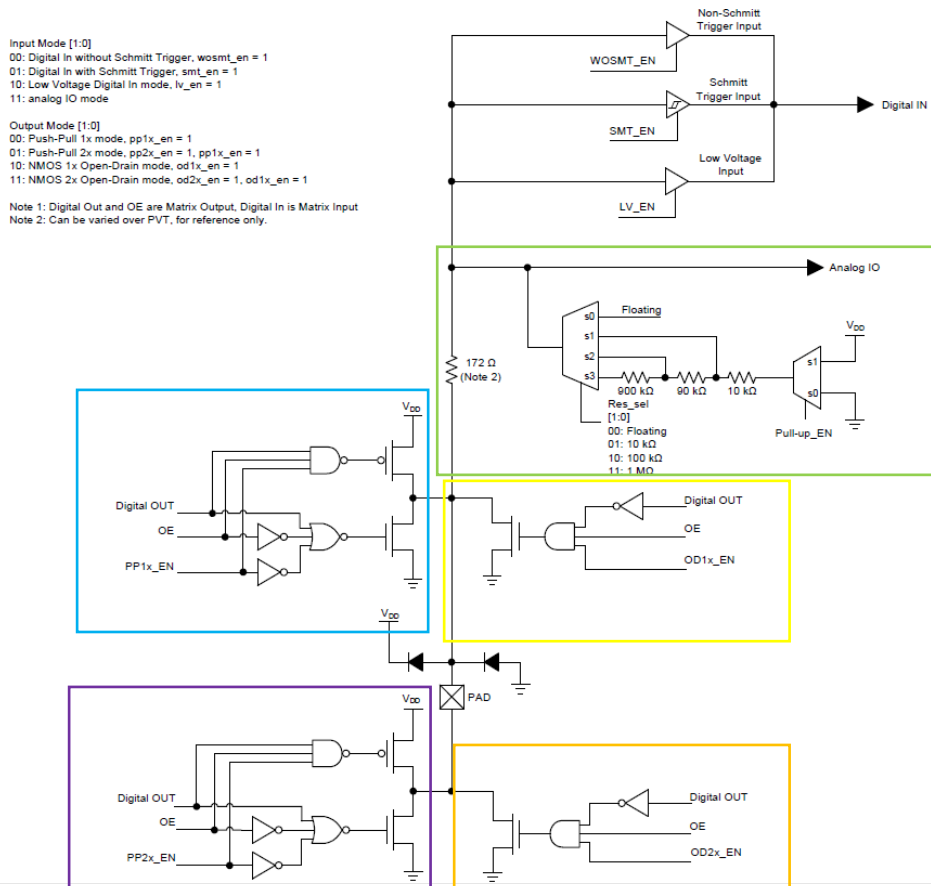

Figure 3: PIN10 (GPIO5)

Table 2 lists every one of GPIO's possible failure modes. It is possible to choose which of the six functions are used in any specific application.

For example, if only the Analog output of GPIO5 is needed, refer only to the failure modes that are defined for the Analog part and select the following failure modes:

- Pull-up/down resistor floating,
- Pull-up/down resistor short to ground,
- Pull-up/down resistor short to supply,
- Wrong pull-up/down resistor,
- Pull-down/up resistor instead of pull-up/down.

The total failure rate related to GPIO5 could be achieved by selecting the failure modes and by referring to the failure rates of the GreenPAK functions (see Table 6).

Note: GPIO5 with six different functions has a 1/6 (17%) failure distribution for each specific function if it fails. For each function this failure rate distribution must be split to the number of failure modes of that specific function.

For example, the Analog output of GPIO5 has a 17% total amount of failure rate distribution, and because of the five possible failure modes there is 17%/5 (3.4%) distribution of the failure.

Table 9, Table 10, and Table 11 show the failure rate analysis for the GPIO5 digital output, digital input, and analog input/output modes.

Table 9: GPIO5 (PIN10) Digital Output Safety Analysis

Function	Failure Mode	Failure Mode Distribution [%]	Failure Rate [%]
GPIO Digital output	Stuck at	5.7	0.08

	Wrong selection of input circuitry	5.7	0.08
	Floating	5.7	0.08

Table 10: GPIO5 (PIN10) Digital Input Safety Analysis

Function	Failure Mode	Failure Mode Distribution [%]	Failure Rate [%]
GPIO Digital Input	Stuck at	5.7	0.08
	Wrong selection of input circuitry	5.7	0.08
	Floating	5.7	0.08

Table 11: GPIO5 (PIN10) Analog Input/Output Safety Analysis

Function	Failure Mode	Failure Mode Distribution [%]	Failure Rate [%]
GPIO Analog Input/output	Pull-up/down resistor Floating	3.4	0.05
	Pull-up/down resistor short to ground	3.4	0.05
	Pull-up/down resistor short to supply	3.4	0.05
	Wrong pull-up/down resistor	3.4	0.05
	Pull down/up resistor instead of pull-up/down	3.4	0.05

7. Conclusion

This application note provides guidance on leveraging the Renesas Automotive GreenPAK products — specifically the SLG46620-AG, SLG46855-AP, SLG46625-AP, SLG46880-AP, SLG46857-AP, SLG47004-AP, SLG46827-AG, and SLG46538-AP — in safety-critical, industrial and automotive applications compliant with IEC 61508 and ISO 26262 standards. By following the guidelines in this document, engineers and developers can confidently integrate Automotive GreenPAKs into their safety-related designs, ensuring both compliance and reliability.

8. Revision History

Revision	Date	Description
1.0	Sep 23, 2024	Initial version.
2.0	Oct 16, 2024	Added the baseline failure rate database according to IEC 62380.
3.0	Jan 23, 2025	New P/Ns included (SLG46857-AP, SLG47004-AP, SLG46827-AG)
4.0	Jun 26, 2025	New P/N SLG46538-AP included and Table 5 refinement

Notice

1. Descriptions of circuits, software and other related information in this document are provided only to illustrate the operation of semiconductor products and application examples. You are fully responsible for the incorporation or any other use of the circuits, software, and information in the design of your product or system. Renesas Electronics disclaims any and all liability for any losses and damages incurred by you or third parties arising from the use of these circuits, software, or information.
 2. Renesas Electronics hereby expressly disclaims any warranties against and liability for infringement or any other claims involving patents, copyrights, or other intellectual property rights of third parties, by or arising from the use of Renesas Electronics products or technical information described in this document, including but not limited to, the product data, drawings, charts, programs, algorithms, and application examples.
 3. No license, express, implied or otherwise, is granted hereby under any patents, copyrights or other intellectual property rights of Renesas Electronics or others.
 4. You shall be responsible for determining what licenses are required from any third parties, and obtaining such licenses for the lawful import, export, manufacture, sales, utilization, distribution or other disposal of any products incorporating Renesas Electronics products, if required.
 5. You shall not alter, modify, copy, or reverse engineer any Renesas Electronics product, whether in whole or in part. Renesas Electronics disclaims any and all liability for any losses or damages incurred by you or third parties arising from such alteration, modification, copying or reverse engineering.
 6. Renesas Electronics products are classified according to the following two quality grades: "Standard" and "High Quality". The intended applications for each Renesas Electronics product depends on the product's quality grade, as indicated below.
 - "Standard": Computers; office equipment; communications equipment; test and measurement equipment; audio and visual equipment; home electronic appliances; machine tools; personal electronic equipment; industrial robots; etc.
 - "High Quality": Transportation equipment (automobiles, trains, ships, etc.); traffic control (traffic lights); large-scale communication equipment; key financial terminal systems; safety control equipment; etc.
- Unless expressly designated as a high reliability product or a product for harsh environments in a Renesas Electronics data sheet or other Renesas Electronics document, Renesas Electronics products are not intended or authorized for use in products or systems that may pose a direct threat to human life or bodily injury (artificial life support devices or systems; surgical implantations; etc.), or may cause serious property damage (space system; undersea repeaters; nuclear power control systems; aircraft control systems; key plant systems; military equipment; etc.). Renesas Electronics disclaims any and all liability for any damages or losses incurred by you or any third parties arising from the use of any Renesas Electronics product that is inconsistent with any Renesas Electronics data sheet, user's manual or other Renesas Electronics document.
7. No semiconductor product is absolutely secure. Notwithstanding any security measures or features that may be implemented in Renesas Electronics hardware or software products, Renesas Electronics shall have absolutely no liability arising out of any vulnerability or security breach, including but not limited to any unauthorized access to or use of a Renesas Electronics product or a system that uses a Renesas Electronics product. RENESAS ELECTRONICS DOES NOT WARRANT OR GUARANTEE THAT RENESAS ELECTRONICS PRODUCTS, OR ANY SYSTEMS CREATED USING RENESAS ELECTRONICS PRODUCTS WILL BE INVULNERABLE OR FREE FROM CORRUPTION, ATTACK, VIRUSES, INTERFERENCE, HACKING, DATA LOSS OR THEFT, OR OTHER SECURITY INTRUSION ("Vulnerability Issues"). RENESAS ELECTRONICS DISCLAIMS ANY AND ALL RESPONSIBILITY OR LIABILITY ARISING FROM OR RELATED TO ANY VULNERABILITY ISSUES. FURTHERMORE, TO THE EXTENT PERMITTED BY APPLICABLE LAW, RENESAS ELECTRONICS DISCLAIMS ANY AND ALL WARRANTIES, EXPRESS OR IMPLIED, WITH RESPECT TO THIS DOCUMENT AND ANY RELATED OR ACCOMPANYING SOFTWARE OR HARDWARE, INCLUDING BUT NOT LIMITED TO THE IMPLIED WARRANTIES OF MERCHANTABILITY, OR FITNESS FOR A PARTICULAR PURPOSE.
 8. When using Renesas Electronics products, refer to the latest product information (data sheets, user's manuals, application notes, "General Notes for Handling and Using Semiconductor Devices" in the reliability handbook, etc.), and ensure that usage conditions are within the ranges specified by Renesas Electronics with respect to maximum ratings, operating power supply voltage range, heat dissipation characteristics, installation, etc. Renesas Electronics disclaims any and all liability for any malfunctions, failure or accident arising out of the use of Renesas Electronics products outside of such specified ranges.
 9. Although Renesas Electronics endeavors to improve the quality and reliability of Renesas Electronics products, semiconductor products have specific characteristics, such as the occurrence of failure at a certain rate and malfunctions under certain use conditions. Unless designated as a high reliability product or a product for harsh environments in a Renesas Electronics data sheet or other Renesas Electronics document, Renesas Electronics products are not subject to radiation resistance design. You are responsible for implementing safety measures to guard against the possibility of bodily injury, injury or damage caused by fire, and/or danger to the public in the event of a failure or malfunction of Renesas Electronics products, such as safety design for hardware and software, including but not limited to redundancy, fire control and malfunction prevention, appropriate treatment for aging degradation or any other appropriate measures. Because the evaluation of microcomputer software alone is very difficult and impractical, you are responsible for evaluating the safety of the final products or systems manufactured by you.
 10. Please contact a Renesas Electronics sales office for details as to environmental matters such as the environmental compatibility of each Renesas Electronics product. You are responsible for carefully and sufficiently investigating applicable laws and regulations that regulate the inclusion or use of controlled substances, including without limitation, the EU RoHS Directive, and using Renesas Electronics products in compliance with all these applicable laws and regulations. Renesas Electronics disclaims any and all liability for damages or losses occurring as a result of your noncompliance with applicable laws and regulations.
 11. Renesas Electronics products and technologies shall not be used for or incorporated into any products or systems whose manufacture, use, or sale is prohibited under any applicable domestic or foreign laws or regulations. You shall comply with any applicable export control laws and regulations promulgated and administered by the governments of any countries asserting jurisdiction over the parties or transactions.
 12. It is the responsibility of the buyer or distributor of Renesas Electronics products, or any other party who distributes, disposes of, or otherwise sells or transfers the product to a third party, to notify such third party in advance of the contents and conditions set forth in this document.
 13. This document shall not be reprinted, reproduced or duplicated in any form, in whole or in part, without prior written consent of Renesas Electronics.
 14. Please contact a Renesas Electronics sales office if you have any questions regarding the information contained in this document or Renesas Electronics products.

(Note1) "Renesas Electronics" as used in this document means Renesas Electronics Corporation and also includes its directly or indirectly controlled subsidiaries.

(Note2) "Renesas Electronics product(s)" means any product developed or manufactured by or for Renesas Electronics.

(Disclaimer Rev.5.0-1)

Corporate Headquarters

TOYOSU FORESIA, 3-2-24 Toyosu,
Koto-ku, Tokyo 135-0061, Japan
www.renesas.com

Trademarks

Renesas and the Renesas logo are trademarks of Renesas Electronics Corporation. All trademarks and registered trademarks are the property of their respective owners.

Contact Information

For further information on a product, technology, the most up-to-date version of a document, or your nearest sales office, please visit:
www.renesas.com/contact/