

Abstract

The [e-CAM22_CURG3E](#) and [e-CAM25_CURG3E](#) are partner camera modules for the [RZ/G3E EVKIT](#). This guide provides key points when you use the e-CAM22_CURG3E and e-CAM25_CURG3E, and port the environment to your own custom board.

Target Device

- RZ/G3E

Available Camera Modules

- e-CAM22_CURG3E
- e-CAM25_CURG3E

Note

Please make sure that the part number (P/N) of the camera module is correct. Do not purchase the camera modules intended for the RZ/V series (e.g., e-CAM22_CURZH).

Table of Contents

1. Introduction	3
2. Camera Environment Setup and Development for Custom Board	4
2.1 Setting Up Camera Environment on RZ/G3E EVKIT	4
2.2 Environment Setup for Porting to Custom Board	7
REVISION HISTORY	13

1. Introduction

The RZ/G3E EVKIT supports a MIPI-CSI2 interface. As partner camera modules, the e-CAM22_CURG3E and e-CAM25_CURG3E are available. **Table 1.1** lists the specifications of these camera modules. The most important difference is the shutter type. The shutter type of the e-CAM22_CURG3E is Rolling shutter, so the cost is low. In addition, it is superior in low-light conditions. On the other hand, the shutter type of the e-CAM25_CURG3E is Global shutter, so it is suitable for capturing moving objects. Note that the RZ/G3E has no ISP interface. Therefore, both camera modules have an ISP interface. For detailed information, refer to the webpage of e-con Systems.

The software is provided by e-con Systems. If you need it, please contact e-con Systems.

Table 1.1 Available Partner Camera Module List

Part Number	Image Sensor	Type	Camera Spec (Pixel / Shutter Type)	ISP
e-CAM22_CURG3E	IMX462	YUV	2 MP / Rolling shutter	On camera module
e-CAM25_CURG3E	AR0234	YUV	2 MP / Global shutter	On camera module

2. Camera Environment Setup and Development for Custom Board

This section explains how to set up an e-CAM environment using the RZ/G3E EVKIT, and how to port the environment to your own custom board. Software (patch files) from e-con Systems is also required. If you need it, please contact e-con Systems.

2.1 Setting Up Camera Environment on RZ/G3E EVKIT

Figure 2.1 shows block diagrams of the RZ/G3E EVKIT. As you can see, the pins for RIIC channel 0 and MIPI-CSI2 are assigned for the camera module. Figure 2.2 shows the picture of the RZ/G3E EVKIT. Only CAM_CS11 is available. The e-CAM22_CURG3E and e-CAM25_CURG3E can be connected to the RZ/G3E EVKIT via the Pi Camera Adaptor (packaged with the RZ/G3E EVKIT) and a flexi cable.

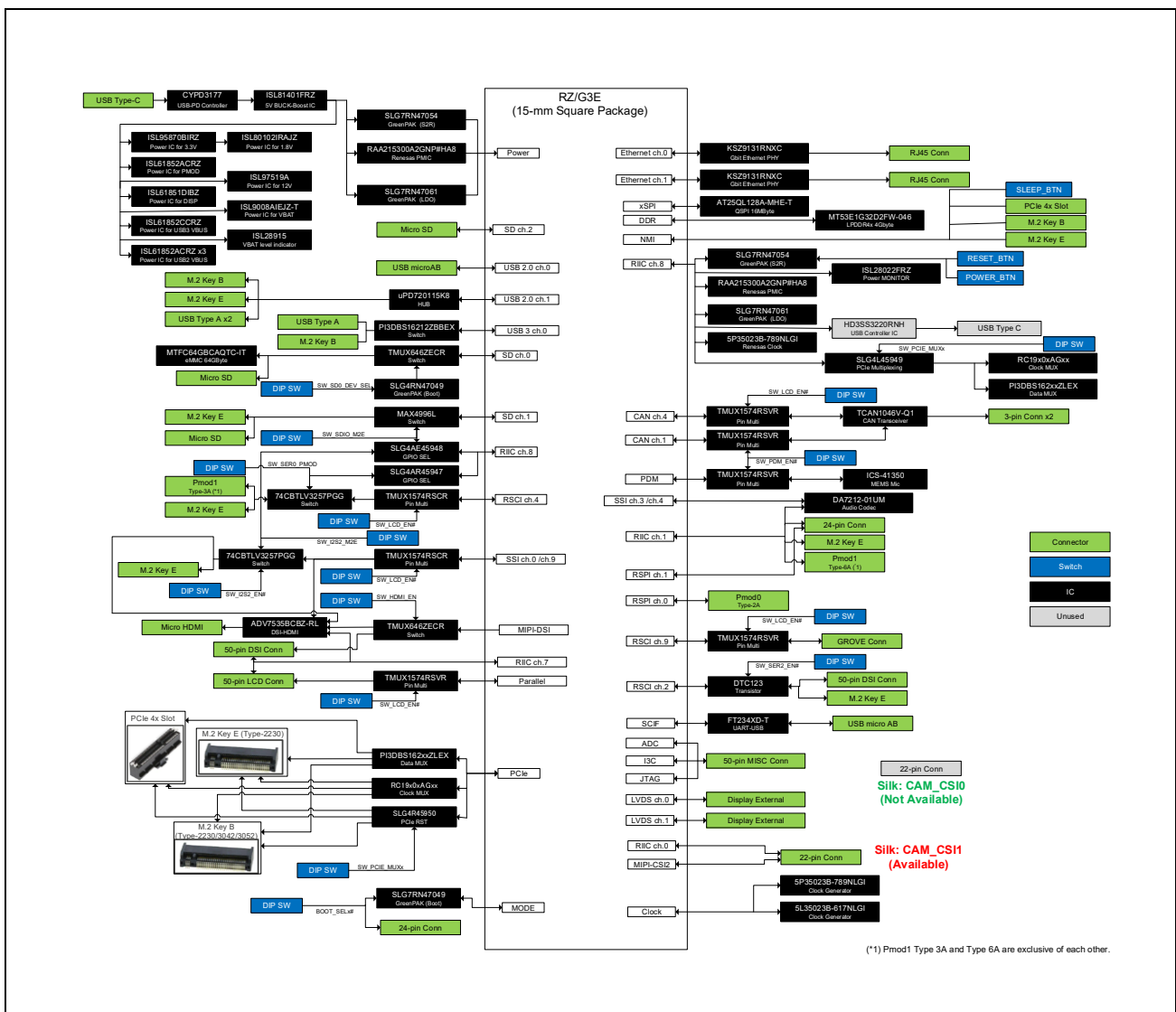

Figure 2.1 Block Diagram of RZ/G3E EVKIT

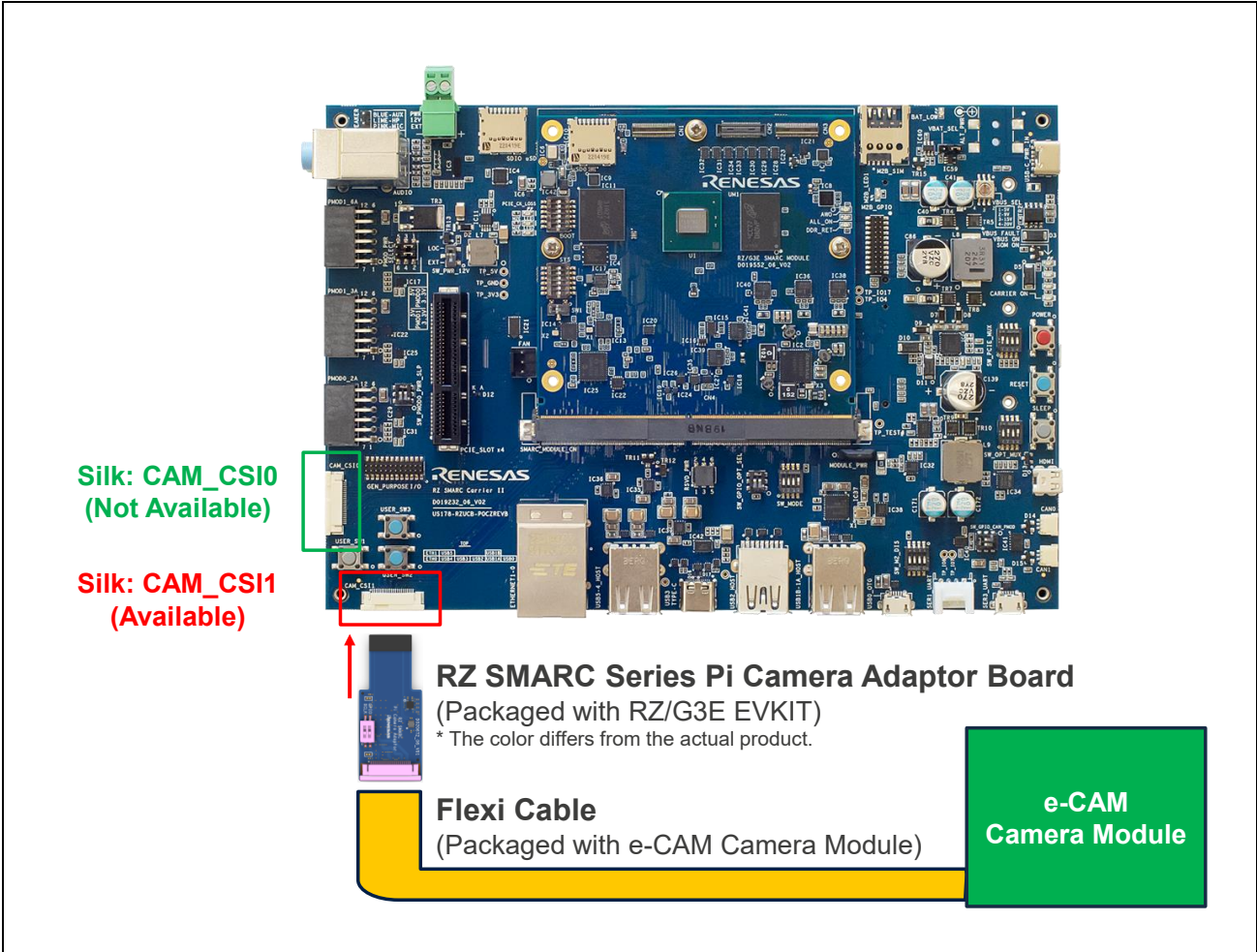

Figure 2.2 Connector for Camera Module on RZ/G3E EVKIT

Table 2.1 and **Table 2.2** list the pin assignments for MIPI-CSI2 on the RZ/G3E EVKIT. The pins for RIIC channel 0 are multi-function pins, and assigned in a device tree file*¹. When you use the camera interface on your custom board, do not forget to assign these pins.

The software for the RZ/G3E EVKIT is provided by e-con Systems. For information on how to modify the software to run e-CAM on the RZ/G3E EVKIT based on Renesas BSP, refer to the materials provided by e-con Systems.

Note 1. Located in <working directory>/build/tmp/work-shared/smarc-rzg3e/kernel-source/arch/arm64/boot/dts/Renesas/smarc-rzg3e.dtsi

Table 2.1 Pin Assignment for CSI

Pin Location (15-mm Square Package)	Pin Name	Function	
		RZ/G3E EVK (BSP v1.0.0)	Description
AF28	CSI0_CLKP	CSI0_CLKP	Dedicated pin
AH28	CSI0_CLKN	CSI0_CLKN	Dedicated pin
AJ26	CSI_DATA0P	CSI_DATA0P	Dedicated pin
AH25	CSI_DATA0N	CSI_DATA0N	Dedicated pin
AJ27	CSI_DATA1P	CSI_DATA1P	Dedicated pin
AH27	CSI_DATA1N	CSI_DATA1N	Dedicated pin
AH29	CSI_DATA2P	CSI_DATA2P	Dedicated pin
AG28	CSI_DATA2N	CSI_DATA2N	Dedicated pin
AG29	CSI_DATA3P	CSI_DATA3P	Dedicated pin
AF28	CSI_DATA3N	CSI_DATA3N	Dedicated pin

Table 2.2 Pin Assignment for RIIC Channel 0

Pin Location (15-mm Square Package)	Pin Name	Function	
		RZ/G3E EVK (BSP v1.0.0)	Description
AF28	PD4	I2C_CAM_CK (Function 4)	Multi-function pin
AH28	PD5	I2C_CAM_DAT (Function 4)	Multi-function pin

2.2 Environment Setup for Porting to Custom Board

When you build with the patch file from e-con Systems (e-CAM22_CURG3E_REL_1.0.patch or e-CAM25_CURG3E_REL_1.0.patch), a device tree file*¹ is automatically modified. However, when you create the device tree file for your own custom board, the patch file does not work. Therefore, when you port this environment to your own custom board, include the following change on your device tree file.

For the information about how to build the image, refer to the manual from e-con Systems and the [RZ/G3E Linux Start-up Guide](#).

Note 1. Located in <working directory>/build/tmp/work-shared/smarc-rzg3e/kernel-source/arch/arm64/boot/dts/renesas/smarc-rzg3e.dtsi

(1) BSP v.1.0.0

```
1 / {
2     :
3     :
4     ov5645_fixed_clk: osc25250-clk {
5         compatible = "fixed-clock";
6         #clock-cells = <0>;
7         clock-frequency = <24000000>;
8     };
9     ov5645_vddo_1v8: 1p8v {
10        compatible = "regulator-fixed";
11        regulator-name = "camera_vddo";
12        regulator-min-microvolt = <1800000>;
13        regulator-max-microvolt = <1800000>;
14        regulator-always-on;
15    };
16    ov5645_vdda_2v8: 2p8v {
17        compatible = "regulator-fixed";
18        regulator-name = "camera_vdda";
19        regulator-min-microvolt = <2800000>;
20        regulator-max-microvolt = <2800000>;
21        regulator-always-on;
22    };
23    ov5645_vddd_1v5: 1p5v {
24        compatible = "regulator-fixed";
25        regulator-name = "camera_vddd";
26        regulator-min-microvolt = <1500000>;
27        regulator-max-microvolt = <1500000>;
28        regulator-always-on;
29    };
30
31 };
```

```
1  &i2c0 {
2      pinctrl-0 = <&i2c0_pins>;
3      pinctrl-names = "default";
4      status = "okay";
5      ov5645_csi2: ov5645_csi2@3c {
6          compatible = "ovti,ov5645";
7          reg = <0x3c>;
8          clocks = <&ov5645_fixed_clk>;
9          clock-frequency = <24000000>;
10         vdddo-supply = <&ov5645_vdddo_1v8>;
11         vdda-supply = <&ov5645_vdda_2v8>;
12         vddd-supply = <&ov5645_vddd_1v5>;
13         enable-gpios = <&pinctrl RZV2H_GPIO(D, 6) GPIO_ACTIVE_HIGH>;
14         reset-gpios = <&pinctrl RZV2H_GPIO(D, 7) GPIO_ACTIVE_LOW>;
15         port {
16             ov5645_to_csi2: endpoint {
17                 clock-lanes = <0>;
18                 data-lanes = <1 2>;
19                 remote-endpoint = <&csi2_in>;
20             };
21         };
22     };
23 };
24
25 &cru {
26     status = "okay";
27 };
28
29 &csi2 {
30     status = "okay";
31     ports {
32         port {
33             csi2_in: endpoint {
34                 clock-lanes = <0>;
35                 data-lanes = <1 2>;
36                 remote-endpoint = <&ov5645_to_csi2>;
37             };
38         };
39     };
40 };
41
```

(2) e-CAM22

```
1 / {
2     :
3     :
4     imx462_fixed_clk: osc25250-clk {
5         compatible = "fixed-clock";
6         #clock-cells = <0>;
7         clock-frequency = <24000000>;
8     };
9     imx462_vdddo_1v8: 1p8v {
10        compatible = "regulator-fixed";
11        regulator-name = "camera_vdddo";
12        regulator-min-microvolt = <1800000>;
13        regulator-max-microvolt = <1800000>;
14        regulator-always-on;
15    };
16    imx462_vdda_2v8: 2p8v {
17        compatible = "regulator-fixed";
18        regulator-name = "camera_vdda";
19        regulator-min-microvolt = <2800000>;
20        regulator-max-microvolt = <2800000>;
21        regulator-always-on;
22    };
23    imx462_vddd_1v5: 1p5v {
24        compatible = "regulator-fixed";
25        regulator-name = "camera_vddd";
26        regulator-min-microvolt = <1500000>;
27        regulator-max-microvolt = <1500000>;
28        regulator-always-on;
29    };
30
31 };
```

```
1  &i2c0 {
2      pinctrl-0 = <&i2c0_pins>;
3      pinctrl-names = "default";
4      status = "okay";
5      clock-frequency = <400000>;
6      pca6408_0: pca6408_0@20
7          {
8              compatible = "ti,pca6408";
9              gpio-controller;
10             #gpio-cells = <2>;
11             reg = <0x20>;
12             status = "okay";
13         };
14     imx462_csi2: imx462_csi2@1f {
15         compatible = "imx462";
16         reg = <0x1f>;
17         clocks-names = "xclk";
18         clocks = <&imx462_fixed_clk>;
19         clock-frequency = <24000000>;
20         camera-mipi-clk = <800>;
21         camera-mipi-lanes = <4>;
22         vdddo-supply = <&imx462_vdddo_1v8>;
23         vdda-supply = <&imx462_vdda_2v8>;
24         vddd-supply = <&imx462_vddd_1v5>;
25         pwn-gpios = <&pca6408_0 0 GPIO_ACTIVE_HIGH>;
26         reset-gpios = <&pca6408_0 1 GPIO_ACTIVE_HIGH>;
27         status = "okay";
28         port {
29             imx462_to_csi2: endpoint {
30                 clock-lanes = <0>;
31                 data-lanes = <1 2 3 4>;
32                 remote-endpoint = <&csi2_in>;
33             };
34         };
35     };
36 };
37
38 &cru {
39     status = "okay";
40 };
41
42 &csi2 {
43     status = "okay";
44     ports {
45         port {
46             csi2_in: endpoint {
47                 clock-lanes = <0>;
48                 data-lanes = <1 2 3 4>;
49                 remote-endpoint = <&imx462_to_csi2>;
50             };
51         };
52     };
53 };
```

(3) e-CAM25

```

1  / {
2      :
3      :
4
5      ar0234_fixed_clk: osc25250-clk {
6          compatible = "fixed-clock";
7          #clock-cells = <0>;
8          clock-frequency = <24000000>;
9      };
10     ar0234_vdddo_1v8: 1p8v {
11         compatible = "regulator-fixed";
12         regulator-name = "camera_vdddo";
13         regulator-min-microvolt = <1800000>;
14         regulator-max-microvolt = <1800000>;
15         regulator-always-on;
16     };
17     ar0234_vdda_2v8: 2p8v {
18         compatible = "regulator-fixed";
19         regulator-name = "camera_vdda";
20         regulator-min-microvolt = <2800000>;
21         regulator-max-microvolt = <2800000>;
22         regulator-always-on;
23     };
24     ar0234_vddd_1v5: 1p5v {
25         compatible = "regulator-fixed";
26         regulator-name = "camera_vddd";
27         regulator-min-microvolt = <1500000>;
28         regulator-max-microvolt = <1500000>;
29         regulator-always-on;
30     };
31
32 };

```

```
1  &i2c0 {
2      pinctrl-0 = <&i2c0_pins>;
3      pinctrl-names = "default";
4      status = "okay";
5      clock-frequency = <400000>;
6      pca6408_0: pca6408_0@20 {
7          compatible = "ti,pca6408";
8          gpio-controller;
9          #gpio-cells = <2>;
10         reg = <0x20>;
11         status = "okay";
12     };
13     ar0234_csi2: ar0234_csi2@42 {
14         compatible = "ar0234";
15         reg = <0x42>;
16         clocks = <&ar0234_fixed_clk>;
17         clock-frequency = <24000000>;
18         vdddo-supply = <&ar0234_vdddo_1v8>;
19         vdda-supply = <&ar0234_vdda_2v8>;
20         vddd-supply = <&ar0234_vddd_1v5>;
21         pwn-gpios = <&pca6408_0 0 GPIO_ACTIVE_HIGH>;
22         reset-gpios = <&pca6408_0 1 GPIO_ACTIVE_HIGH>;
23         status = "okay";
24         port {
25             ar0234_to_csi2: endpoint {
26                 clock-lanes = <0>;
27                 data-lanes = <1 2 3 4>;
28                 remote-endpoint = <&csi2_in>;
29             };
30         };
31     };
32 };
33
34 &cru {
35     status = "okay";
36 };
37
38 &csi2 {
39     status = "okay";
40     ports {
41         port {
42             csi2_in: endpoint {
43                 clock-lanes = <0>;
44                 data-lanes = <1 2 3 4>;
45                 remote-endpoint = <&ar0234_to_csi2>;
46             };
47         };
48     };
49 };
```

REVISION HISTORY	e-con Camera Module Setup Guide for RZ/G3E EVKIT
------------------	--

Rev.	Date	Description	
		Page	Summary
1.00	Nov. 17, 2025	—	First edition issued

General Precautions in the Handling of Microprocessing Unit and Microcontroller Unit Products

The following usage notes are applicable to all Microprocessing unit and Microcontroller unit products from Renesas. For detailed usage notes on the products covered by this document, refer to the relevant sections of the document as well as any technical updates that have been issued for the products.

1. Precaution against Electrostatic Discharge (ESD)

A strong electrical field, when exposed to a CMOS device, can cause destruction of the gate oxide and ultimately degrade the device operation. Steps must be taken to stop the generation of static electricity as much as possible, and quickly dissipate it when it occurs. Environmental control must be adequate. When it is dry, a humidifier should be used. This is recommended to avoid using insulators that can easily build up static electricity. Semiconductor devices must be stored and transported in an anti-static container, static shielding bag or conductive material. All test and measurement tools including work benches and floors must be grounded. The operator must also be grounded using a wrist strap. Semiconductor devices must not be touched with bare hands. Similar precautions must be taken for printed circuit boards with mounted semiconductor devices.

2. Processing at power-on

The state of the product is undefined at the time when power is supplied. The states of internal circuits in the LSI are indeterminate and the states of register settings and pins are undefined at the time when power is supplied. In a finished product where the reset signal is applied to the external reset pin, the states of pins are not guaranteed from the time when power is supplied until the reset process is completed. In a similar way, the states of pins in a product that is reset by an on-chip power-on reset function are not guaranteed from the time when power is supplied until the power reaches the level at which resetting is specified.

3. Input of signal during power-off state

Do not input signals or an I/O pull-up power supply while the device is powered off. The current injection that results from input of such a signal or I/O pull-up power supply may cause malfunction and the abnormal current that passes in the device at this time may cause degradation of internal elements. Follow the guideline for input signal during power-off state as described in your product documentation.

4. Handling of unused pins

Handle unused pins in accordance with the directions given under handling of unused pins in the manual. The input pins of CMOS products are generally in the high-impedance state. In operation with an unused pin in the open-circuit state, extra electromagnetic noise is induced in the vicinity of the LSI, an associated shoot-through current flows internally, and malfunctions occur due to the false recognition of the pin state as an input signal become possible.

5. Clock signals

After applying a reset, only release the reset line after the operating clock signal becomes stable. When switching the clock signal during program execution, wait until the target clock signal is stabilized. When the clock signal is generated with an external resonator or from an external oscillator during a reset, ensure that the reset line is only released after full stabilization of the clock signal. Additionally, when switching to a clock signal produced with an external resonator or by an external oscillator while program execution is in progress, wait until the target clock signal is stable.

6. Voltage application waveform at input pin

Waveform distortion due to input noise or a reflected wave may cause malfunction. If the input of the CMOS device stays in the area between V_{IL} (Max.) and V_{IH} (Min.) due to noise, for example, the device may malfunction. Take care to prevent chattering noise from entering the device when the input level is fixed, and also in the transition period when the input level passes through the area between V_{IL} (Max.) and V_{IH} (Min.).

7. Prohibition of access to reserved addresses

Access to reserved addresses is prohibited. The reserved addresses are provided for possible future expansion of functions. Do not access these addresses as the correct operation of the LSI is not guaranteed.

8. Differences between products

Before changing from one product to another, for example to a product with a different part number, confirm that the change will not lead to problems. The characteristics of a microprocessing unit or microcontroller unit products in the same group but having a different part number might differ in terms of internal memory capacity, layout pattern, and other factors, which can affect the ranges of electrical characteristics, such as characteristic values, operating margins, immunity to noise, and amount of radiated noise. When changing to a product with a different part number, implement a system-evaluation test for the given product.

Notice

1. Descriptions of circuits, software and other related information in this document are provided only to illustrate the operation of semiconductor products and application examples. You are fully responsible for the incorporation or any other use of the circuits, software, and information in the design of your product or system. Renesas Electronics disclaims any and all liability for any losses and damages incurred by you or third parties arising from the use of these circuits, software, or information.
2. Renesas Electronics hereby expressly disclaims any warranties against and liability for infringement or any other claims involving patents, copyrights, or other intellectual property rights of third parties, by or arising from the use of Renesas Electronics products or technical information described in this document, including but not limited to, the product data, drawings, charts, programs, algorithms, and application examples.
3. No license, express, implied or otherwise, is granted hereby under any patents, copyrights or other intellectual property rights of Renesas Electronics or others.
4. You shall be responsible for determining what licenses are required from any third parties, and obtaining such licenses for the lawful import, export, manufacture, sales, utilization, distribution or other disposal of any products incorporating Renesas Electronics products, if required.
5. You shall not alter, modify, copy, or reverse engineer any Renesas Electronics product, whether in whole or in part. Renesas Electronics disclaims any and all liability for any losses or damages incurred by you or third parties arising from such alteration, modification, copying or reverse engineering.
6. Renesas Electronics products are classified according to the following two quality grades: "Standard" and "High Quality". The intended applications for each Renesas Electronics product depends on the product's quality grade, as indicated below.

"Standard": Computers; office equipment; communications equipment; test and measurement equipment; audio and visual equipment; home electronic appliances; machine tools; personal electronic equipment; industrial robots; etc.

"High Quality": Transportation equipment (automobiles, trains, ships, etc.); traffic control (traffic lights); large-scale communication equipment; key financial terminal systems; safety control equipment; etc.

Unless expressly designated as a high reliability product or a product for harsh environments in a Renesas Electronics data sheet or other Renesas Electronics document, Renesas Electronics products are not intended or authorized for use in products or systems that may pose a direct threat to human life or bodily injury (artificial life support devices or systems; surgical implantations; etc.), or may cause serious property damage (space system; undersea repeaters; nuclear power control systems; aircraft control systems; key plant systems; military equipment; etc.). Renesas Electronics disclaims any and all liability for any damages or losses incurred by you or any third parties arising from the use of any Renesas Electronics product that is inconsistent with any Renesas Electronics data sheet, user's manual or other Renesas Electronics document.

7. No semiconductor product is absolutely secure. Notwithstanding any security measures or features that may be implemented in Renesas Electronics hardware or software products, Renesas Electronics shall have absolutely no liability arising out of any vulnerability or security breach, including but not limited to any unauthorized access to or use of a Renesas Electronics product or a system that uses a Renesas Electronics product. RENESAS ELECTRONICS DOES NOT WARRANT OR GUARANTEE THAT RENESAS ELECTRONICS PRODUCTS, OR ANY SYSTEMS CREATED USING RENESAS ELECTRONICS PRODUCTS WILL BE INVULNERABLE OR FREE FROM CORRUPTION, ATTACK, VIRUSES, INTERFERENCE, HACKING, DATA LOSS OR THEFT, OR OTHER SECURITY INTRUSION ("Vulnerability Issues"). RENESAS ELECTRONICS DISCLAIMS ANY AND ALL RESPONSIBILITY OR LIABILITY ARISING FROM OR RELATED TO ANY VULNERABILITY ISSUES. FURTHERMORE, TO THE EXTENT PERMITTED BY APPLICABLE LAW, RENESAS ELECTRONICS DISCLAIMS ANY AND ALL WARRANTIES, EXPRESS OR IMPLIED, WITH RESPECT TO THIS DOCUMENT AND ANY RELATED OR ACCOMPANYING SOFTWARE OR HARDWARE, INCLUDING BUT NOT LIMITED TO THE IMPLIED WARRANTIES OF MERCHANTABILITY, OR FITNESS FOR A PARTICULAR PURPOSE.
8. When using Renesas Electronics products, refer to the latest product information (data sheets, user's manuals, application notes, "General Notes for Handling and Using Semiconductor Devices" in the reliability handbook, etc.), and ensure that usage conditions are within the ranges specified by Renesas Electronics with respect to maximum ratings, operating power supply voltage range, heat dissipation characteristics, installation, etc. Renesas Electronics disclaims any and all liability for any malfunctions, failure or accident arising out of the use of Renesas Electronics products outside of such specified ranges.
9. Although Renesas Electronics endeavors to improve the quality and reliability of Renesas Electronics products, semiconductor products have specific characteristics, such as the occurrence of failure at a certain rate and malfunctions under certain use conditions. Unless designated as a high reliability product or a product for harsh environments in a Renesas Electronics data sheet or other Renesas Electronics document, Renesas Electronics products are not subject to radiation resistance design. You are responsible for implementing safety measures to guard against the possibility of bodily injury, injury or damage caused by fire, and/or danger to the public in the event of a failure or malfunction of Renesas Electronics products, such as safety design for hardware and software, including but not limited to redundancy, fire control and malfunction prevention, appropriate treatment for aging degradation or any other appropriate measures. Because the evaluation of microcomputer software alone is very difficult and impractical, you are responsible for evaluating the safety of the final products or systems manufactured by you.
10. Please contact a Renesas Electronics sales office for details as to environmental matters such as the environmental compatibility of each Renesas Electronics product. You are responsible for carefully and sufficiently investigating applicable laws and regulations that regulate the inclusion or use of controlled substances, including without limitation, the EU RoHS Directive, and using Renesas Electronics products in compliance with all these applicable laws and regulations. Renesas Electronics disclaims any and all liability for damages or losses occurring as a result of your noncompliance with applicable laws and regulations.
11. Renesas Electronics products and technologies shall not be used for or incorporated into any products or systems whose manufacture, use, or sale is prohibited under any applicable domestic or foreign laws or regulations. You shall comply with any applicable export control laws and regulations promulgated and administered by the governments of any countries asserting jurisdiction over the parties or transactions.
12. It is the responsibility of the buyer or distributor of Renesas Electronics products, or any other party who distributes, disposes of, or otherwise sells or transfers the product to a third party, to notify such third party in advance of the contents and conditions set forth in this document.
13. This document shall not be reprinted, reproduced or duplicated in any form, in whole or in part, without prior written consent of Renesas Electronics.
14. Please contact a Renesas Electronics sales office if you have any questions regarding the information contained in this document or Renesas Electronics products.

(Note1) "Renesas Electronics" as used in this document means Renesas Electronics Corporation and also includes its directly or indirectly controlled subsidiaries.

(Note2) "Renesas Electronics product(s)" means any product developed or manufactured by or for Renesas Electronics.

(Rev.5.0-1 October 2020)

Corporate Headquarters

TOYOSU FORESIA, 3-2-24 Toyosu,
Koto-ku, Tokyo 135-0061, Japan
www.renesas.com

Contact information

For further information on a product, technology, the most up-to-date version of a document, or your nearest sales office, please visit:
www.renesas.com/contact/

Trademarks

Renesas and the Renesas logo are trademarks of Renesas Electronics Corporation. All trademarks and registered trademarks are the property of their respective owners.