

Application note

DA9053 / NXP™ i.MX 6DualLite Applications Processor Example Power Connections

AN-PM-31

Abstract

This application note provides the details of the required connectivity between the DA9053 Power Management Integrated Circuit (PMIC) and the NXP™ i.MX 6DualLite or Solo applications processors.

**DA9053 / NXP™ i.MX 6DualLite Applications
Processor Example Power Connections****Contents**

Abstract	1
Contents	2
Figures	3
Tables	3
1 Terms and definitions	3
2 References	3
3 Introduction	4
4 Purpose	4
5 DA9053 description	4
6 NXP™ i.MX 6 DualLite application processor description	7
7 NXP™ i.MX 6 DualLite power supply rails	7
8 DA9053 – i.MX 6DualLite power connections	9
9 Power-up sequence	10
10 Recommended external components	11
11 Power Commander™ initialisation file for NXP™ i.MX 6 DualLite applications processor	13
12 Ordering information	14
13 Suspend and Resume operation	14
14 Host communication	14
15 Additional supplies	15
16 Battery-less operation	15
17 Driver support	15
18 Additional collateral	16
19 Conclusions	16
Revision history	17

**DA9053 / NXP™ i.MX 6DualLite Applications
Processor Example Power Connections**

Figures

Optional, remove if not required. Figure 1: DA9053 system block diagram..... 5
 Figure 2: NXP™ i.MX 6DualLite based system..... 7
 Figure 3: DA9053 / NXP™ i.MX 6DualLite applications processor example configuration 9
 Figure 4: DA9053 power-up sequence matching the NXP™ i.MX 6 DualLite applications processor power-up requirements..... 10

Tables

Optional, remove if not required. TOC \h \z \c "Table" Table 1: DA9053 buck and LDO definition 6
 Table 2: NXP™ i.MX 6DualLite power supply rails 8
 Table 3: Recommended external components 11
 Table 4: DA9053 standard variants 14
 Table 5: DA9053 order codes 14

1 Terms and definitions

PMIC	Power Management Integrated Circuit
DVS	Dynamic Voltage Scaling
HW	Hardware
SW	Software

2 References

- [1] DA9053-00-IDS3a_140114.pdf, Datasheet, Dialog Semiconductor,2014
- [2] AN-PM-007 Suspend and Resume 1r2.pdf, 2015
- [3] AN-PM-010_PCB_Layout_Guidelines_1v3.pdf,2015
- [4] IMX6DQ6SDLHDG.pdf, Hardware Development Guide for i.MX 6Quad, 6Dual, 6DualLite, 6Solo Applications Processors,2013
- [5] DA9053 Reference board, 44-179-115-04-A1,44-179-115-05-A1 or 44-179-115-02-C1, 2014
- [6] DA9053 iMX6DL Sabre schematic, 44-179-09-B1.pdf, 2013

DA9053 / NXP™ i.MX 6DualLite Applications Processor Example Power Connections

3 Introduction

This document is a reference for connectivity between the DA9053 Power Management Integrated Circuit (PMIC) and the NXP™ i.MX 6 DualLite and Solo applications processors for a typical multimedia applications. The i.MX 6 DualLite and the i.MX 6 Solo processors are pin compatible and have compatible power requirements: as such, this document refers to the DualLite version, but is equally applicable to the Solo.

DA9053 PMIC is a highly integrated chip that supports the Dynamic Voltage Scaling (DVS) technology, enabling significant power savings by intelligently managing voltage and frequency changes similar to the technology used in many processors. As a result of its highly-integrated features, the DA9053 PMIC reduces overall system cost and size significantly when compared to an equivalent discrete solution. This document addresses only the power-supply related features; addressing all of the features and functions of the optimised PMIC is beyond the scope of this document.

For further information on the DA9053 please refer to the datasheet available via your local Dialog Sales Office.

For information about the NXP™ i.MX 6 applications processor family, please refer to [NXP™ website](#)

NOTE

Since this document was created Freescale™ has been acquired by NXP™. All references to Freescale™ now apply to NXP™

4 Purpose

This document:

- Briefly introduces the DA9053 PMIC
- Contains information about power domains, component selection, and DA9053 PMIC interconnection with the NXP™ i.MX 6 DualLite applications processor
- Bases its design on the NXP™ i.MX6 DualLite SABRE board

5 DA9053 description

The DA9053 is a highly-integrated PMIC with supply domain flexibility to support a range of multimedia processor platforms, their associated peripherals and user interface functions.

DA9053's applications are, for example, tablet PCs, embedded and industrial modules, mobile internet devices and consumer and in-vehicle infotainment devices.

Along with four buck convertors and 10 LDOs that are required to address the requirements of most i.MX6 DualLite based systems, the DA9053 also includes:

- A dual input charger with power path support
- A white LED boost convertor
- A watchdog timer
- A 3-channel general purpose 10-bit ADC
- A resistive touch screen interface

DA9053 / NXP™ i.MX 6DualLite Applications Processor Example Power Connections

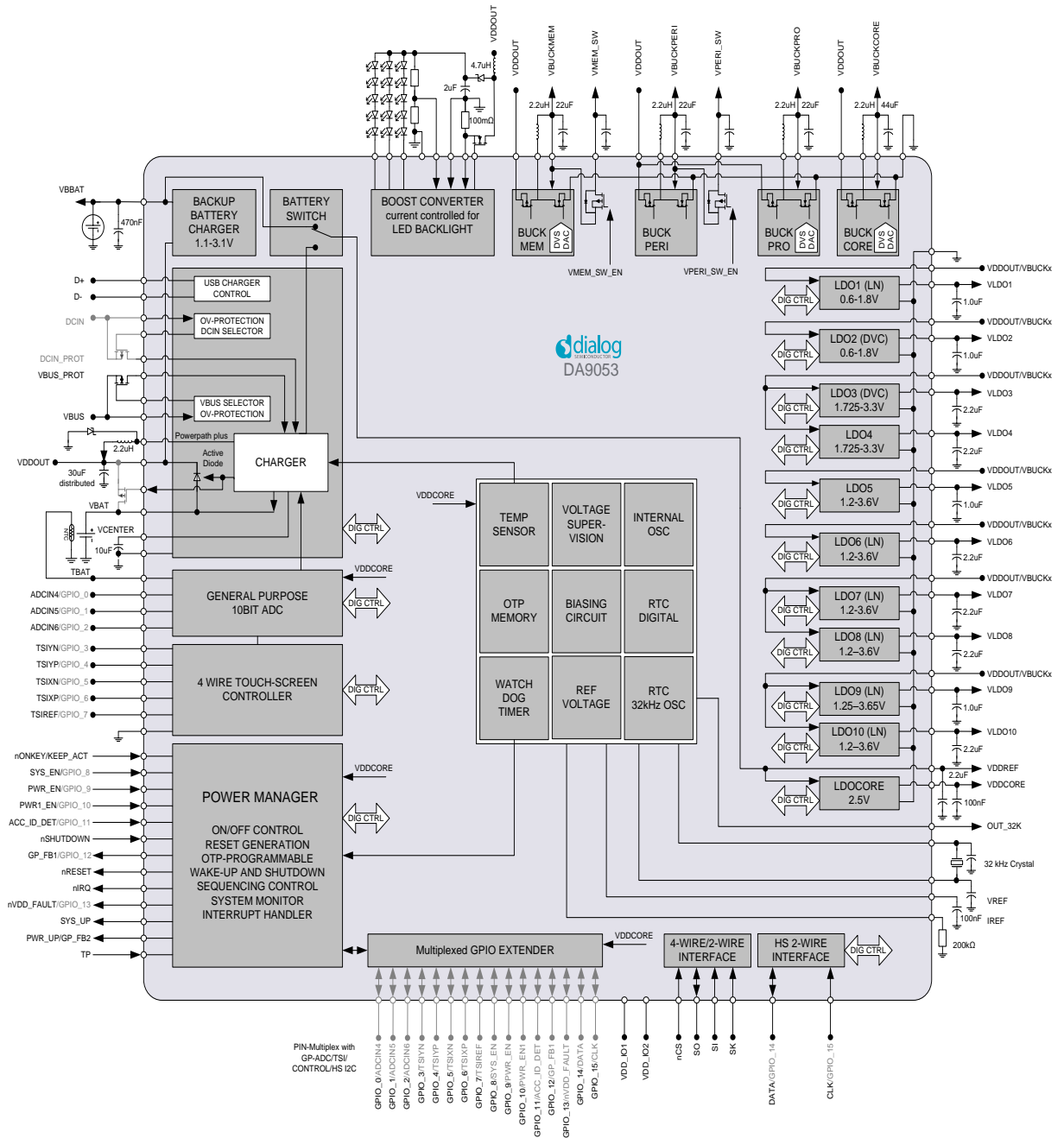

Figure 1: DA9053 system block diagram

DA9053 / NXP™ i.MX 6DualLite Applications Processor Example Power Connections

Table 1: DA9053 buck and LDO definition

Regulator	Output voltage, (Note 1)	Max Current	Notes
BUCKCORE	0.5 – 2.075 V	2000 mA	DVC, 2 MHz, 25 mV steps, DVC ramp with controlled slew rate; pull-down disable
BUCKPRO	0.5 – 2.075 V	1000 mA	DVC, 2 MHz, 25 mV steps, DVC ramp controlled slew rate, pull-down resistor disable, common supply with BUCKPERI
BUCKMEM	0.95 – 2.525 V	1000 mA	DVC, 2 MHz, 25 mV steps, DVC ramp with controlled slew rate pull-down resistor disable 2 nd output with sequencer controllable switch
BUCKPERI	0.95-2.525 V	1000 mA	2 MHz, 25 mV steps, 2 nd output with sequencer controllable switch, common supply with BUCKPRO
BOOST	5 – 25 V	78 mA	Current-controlled boost converter for three strings of up to six serial white LEDs. Over voltage protection via a voltage feedback pin.
LDO1	0.6 – 1.8 V	50 mA	High PSSR, low noise LDO, 50 mV steps, pull-down resistor disable
LDO2	0.6 – 1.8 V	100 mA	Digital LDO, 25 mV steps, DVC ramp with controlled slew rate, pull-down resistor disable
LDO3	1.725 – 3.3 V	200 mA	Digital LDO, 25 mV steps, DVC with controlled slew rate, common supply with LDO4
LDO4	1.725 – 3.3 V	150 mA	Digital LDO, 25 mV steps, optional HW control from GPI1, common supply with LDO3
LDO5	1.2 – 3.6 V	100 mA	Digital LDO, 50 mV steps, pull-down resistor switch off, optional HW control from GPI2,
LDO6	1.2 – 3.6 V	150 mA	High PSRR, low noise, 50 mV steps
LDO7	1.2 – 3.6 V	200 mA	High PSRR, low noise, 50 mV steps, common supply with LDO8
LDO8	1.2 – 3.6 V	200 mA	High PSRR, low noise, 50 mV steps, common supply with LDO7
LDO9	1.25 – 3.6 V ±1 % accuracy, (Note 2)	100 mA	High PSRR, low noise, 50 mV steps, OTP trimmed, optional HW control from GPI12, common supply with LDO10
LDO10	1.2 – 3.6 V	250 mA	High PSRR, low noise, 50 mV steps, common supply with LDO9
BACKUP BATTERY CHARGER	1.1 – 3.1 V	6 mA	100/200 mV steps, configurable current limit between 0.1 and 6 mA, reverse current protection
LDOCORE	2.5 V	4 mA	Not for external use

Note 1 Output accuracy is ± 3 % unless specified

Note 2 At the default voltage (1 % accuracy requires VLDO9 > 1.5 V)

DA9053 / NXP™ i.MX 6DualLite Applications Processor Example Power Connections

6 NXP™ i.MX 6 DualLite applications processor description

The NXP™ i.MX 6 DualLite applications processor is an advanced, highly integrated platform for multimedia-centric devices.

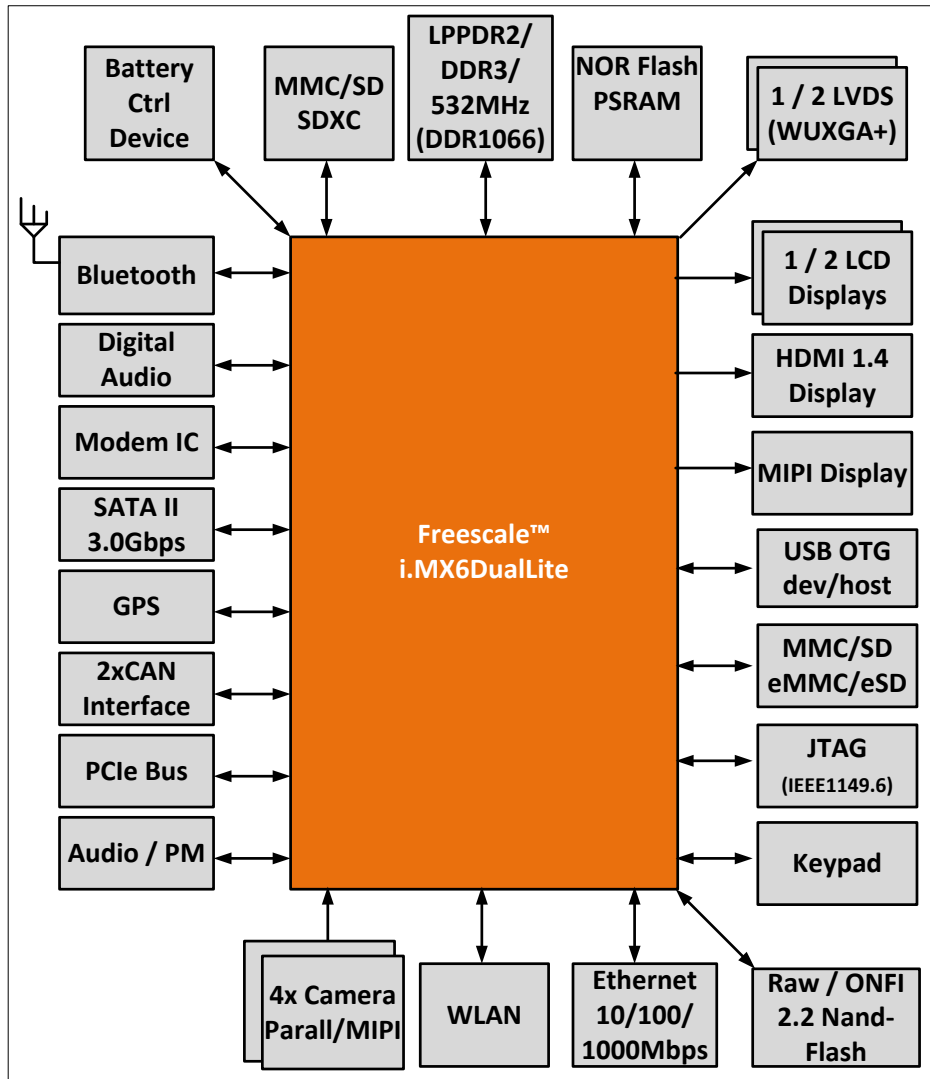

Figure 2: NXP™ i.MX 6DualLite based system

7 NXP™ i.MX 6 DualLite power supply rails

Table 2 shows the NXP™ i.MX 6 DualLite applications processor power supply rails as configured on the NXP™ SABRE board.

DA9053 / NXP™ i.MX 6DualLite Applications Processor Example Power Connections

Table 2: NXP™ i.MX 6DualLite power supply rails

i.MX 6DualLite Power Supply Rail	i.MX 6DualLite SABRE Board Power Rail	DA9053	DA9053 Time Slot	DA9053 Nominal Voltage
VDDARM_IN	VDDCORE	BUCKCORE	TS2	1.375 V
VDDSOC_IN, (Note 3)	VDDSOC	BUCKPRO	TS2	1.375 V
VDDHIGH_IN	VGEN5_2V8	LDO3	TS12	2.8 V
VDD_SNV5_IN, (Note 4, Note 5, Note 6)	PMIC_VSNVS	BBAT	TS0	3.0 V
USB_OTG_VBUS, USB_H1_VBUS		4.4 V to 5.25 V From USB port	NA	NA
NVCC_DRAM	DDR_1V5	BUCKMEM	TS3	1.5 V
NVCC_RGMII, (Note 7)	VGEN1_1V5	LDO6	TS9	1.5 V
NVCC_LCD, NVCC_NANDE, NVCC_SD2, NVCC_SD3, NVCC_EIM0, NVCC_EIM1, NVCC_EIM2, NVCC_JTAG	GEN_3V3	external DC-DC converter enabled by GP_FB2	TS5	3.3 V
NVCC_ENET	VGEN6_3V3	LDO7	TS8	3.3 V
NVCC_SCI, NVCC_SD1	GEN_1V8	BUCKPERI	TS4	1.8 V
NVCC_GPIO	NVCC_GPIO	LDO9	TS5	3.3 V
NVCC_LVDS2P5, (Note 8) NVCC_MIPI	GEN2V5	Connected to i.MX 6Dual VDDHIGH_CAP1/2	NA	
VDDARM23_IN, (Note 9)	GND	GND	NA	GND
VREFDDR, (Note 10)	VREFDDR	LDO1	TS3	0.75 V
	VGEN3_2V5	LDO5	TS12	2.8 V
	AUX_3V15	LDO8	TS7	3.15 V
	VGEN2_1V5	LDO10	TS10	1.5 V
	SPARE1	LDO2	NA	
	SPARE2	LDO4	NA	

Note 3 VDDSOC_CAP and VDDPU_CAP must be equal

Note 4 Care must be taken while setting VDD_SNV5_IN voltage with respect to Charging Currents and RTC, see Hardware Development Guide for i.MX 6Quad, 6Dual, 6DualLite, 6Solo Applications Processors (IMX6DQ6SDLHDG.pdf)

Note 5 Must match the range of voltages that the rechargeable backup battery supports.

Note 6 Should be supplied from the same supply as VDDHIGH_IN, if the system does not require keeping real time and other data on OFF state.

Note 7 All digital I/O supplies (NVCC_XXXX) must be powered under normal conditions whether the associated I/O pins are in use or not, and associated I/O pins need to have a pull-up or pull-down resistor applied to limit any floating gate current.

Note 8 This supply also powers the pre-drivers of the DDR I/O pins; therefore it must always be provided, even when LVDS is not used.

Note 9 For a dual core system, may be shorted to GND together with VDDARM23_CAP to reduce leakage

Note 10 Care should be taken to follow the memory manufacturers recommendations for the generation of VREFDDR. In many cases a simple resistor divider positioned next to the memory devices will suffice.

DA9053 / NXP™ i.MX 6DualLite Applications Processor Example Power Connections

8 DA9053 – i.MX 6DualLite power connections

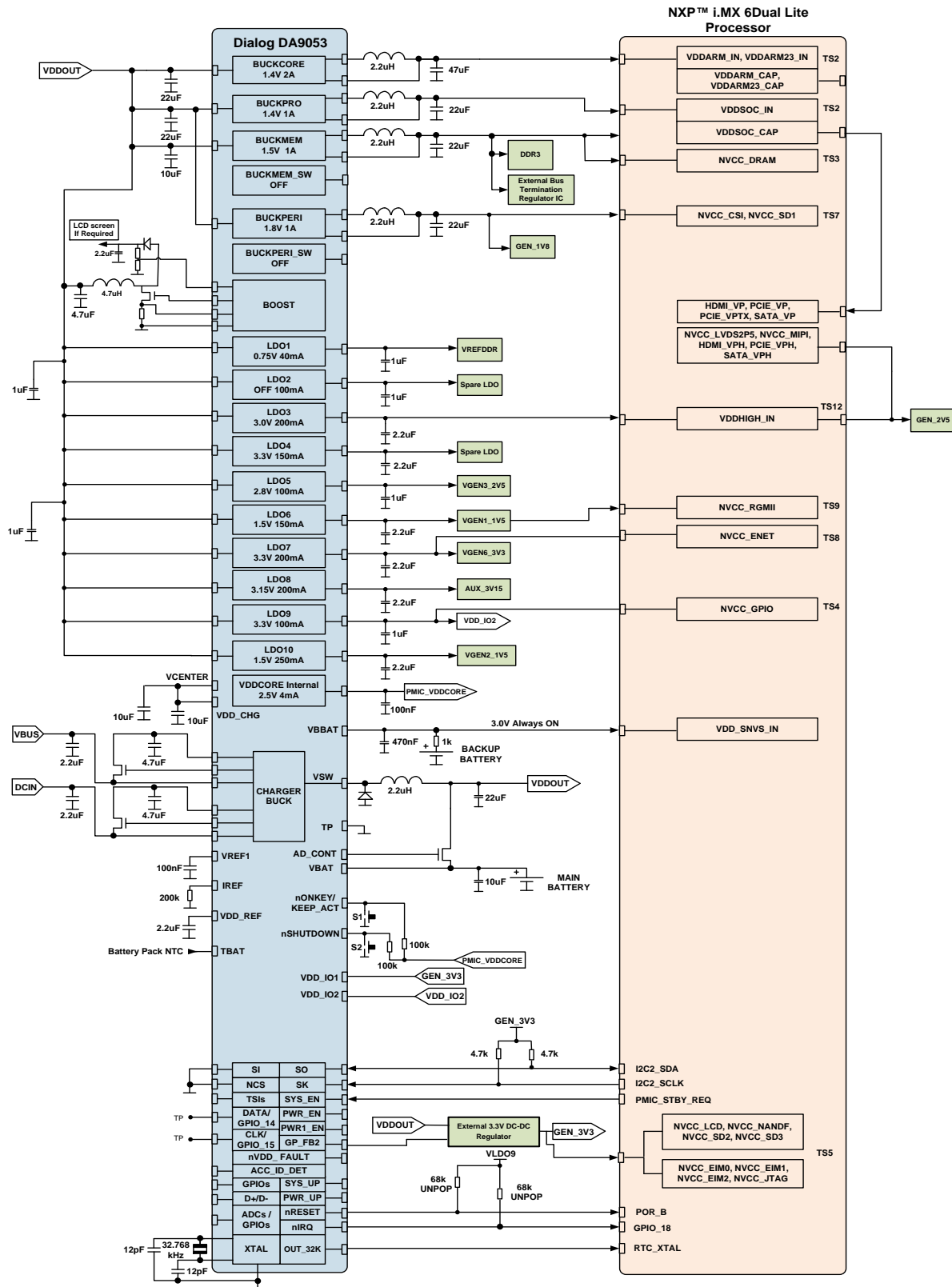

Figure 3: DA9053 / NXP™ i.MX 6DualLite applications processor example configuration

DA9053 / NXP™ i.MX 6DualLite Applications
Processor Example Power Connections

9 Power-up sequence

The following power-up sequence is generated by the DA9053 Power Commander™ GUI.

The start-up behaviour and configuration is fully programmable in the DA9053 OTP and is therefore system agnostic.

The power-up sequence of Figure 4 is designed to meet the NXP™ iMX 6 DualLite start-up requirements as described in the i.MX 6 DualLite applications processor specification.

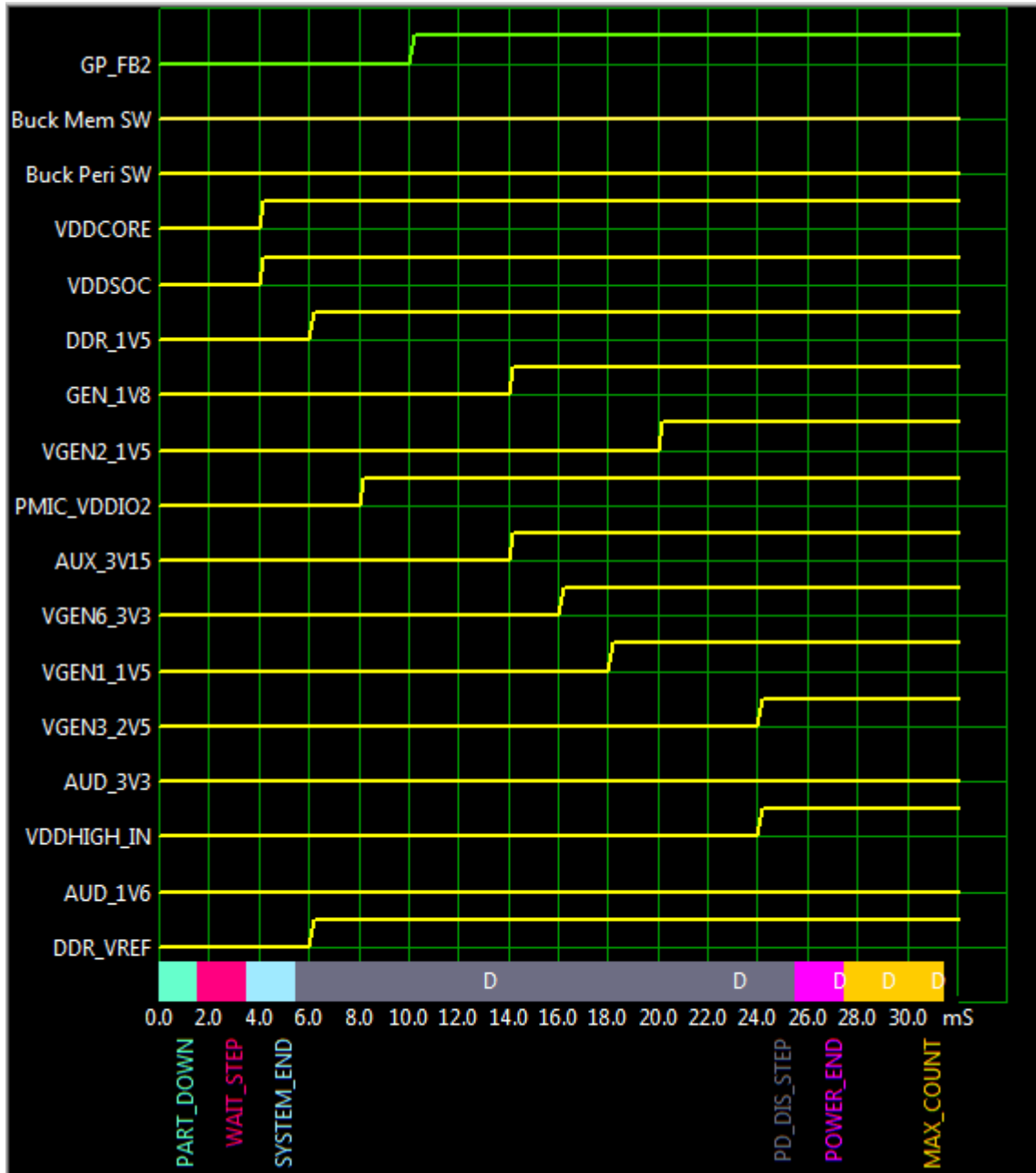

Figure 4: DA9053 power-up sequence matching the NXP™ i.MX 6 DualLite applications processor power-up requirements

DA9053 / NXP™ i.MX 6DualLite Applications Processor Example Power Connections

10 Recommended external components

The following external components are used in the 'DA9053 Reference Board'[5].

Table 3: Recommended external components

Ref Des	Description	Manufacturer	Manufacturer's Part Number	Notes
U	DA9053-PMIC	Dialog	DA9053	
	<u>DA9053 BUCKCORE – 2 A</u>			
L	2.2 μ H SMD 2.7 A inductor	Taiyo Yuden	NR4018T2R2M	Output inductor
C	47 μ F 0805 SMD Ceramic capacitor 4 V X5R	MuRata	GRM21BR60G476ME15	Output capacitor
C	22 μ F 0805 SMD Ceramic capacitor 6.3 V X5R	MuRata	GRM21AR60J226UE80	Input capacitor
	<u>DA9053 BUCKPRO – 1 A</u>			
L	2.2 μ H SMD 1.48 A inductor	Taiyo Yuden	NR3015T2R2M	Output inductor
C	22 μ F 0603 SMD Ceramic capacitor 6.3 V X5R	MuRata	GRM188R60J226ME69	Output capacitor
C	22 μ F 0805 SMD Ceramic capacitor 6.3 V X5R	MuRata	GRM21AR60J226UE80	Input capacitor
	<u>DA9053 BUCKMEM – 1 A</u>			
L	2.2 μ H SMD 1.48 A inductor	Taiyo Yuden	NR3015T2R2M	Output inductor
C	22 μ F 0603 SMD Ceramic capacitor 6.3 V X5R	MuRata	GRM188R60J226ME69	Output capacitor
C	10 μ F 0603 SMD Ceramic capacitor 10 V X5R	MuRata	GRM188R60J106M	Input capacitor
C	0.1 μ F 0402 SMD Ceramic capacitor 16 V X7R	MuRata	GRM155R71C104KA88D	BUCKMEM_SW Output capacitor
	<u>DA9053 BUCKPERI – 1 A</u>			
L	2.2 μ H SMD 1.48 A inductor	Taiyo Yuden	NR3015T2R2M	inductor
C	22 μ F 0603 SMD Ceramic capacitor 6.3 V X5R	MuRata	GRM188R60J226ME69	Output capacitor
C	0.1 μ F 0402 SMD Ceramic capacitor 16 V X7R	MuRata	GRM155R71C104KA88D	BUCKPERI_SW Output capacitor
	<u>DA9053 CHARGER BUCK VDDOUT</u>			
L	2.2 μ H SMD 2.7A inductor	Taiyo Yuden	NR4018T2R2M	VDDOUT Output inductor
C	22 μ F 0603 SMD Ceramic capacitor 10V X7R	Murata	GRM32ER71A226KE15L	VDDOUT Output capacitor
C	22 μ F 0603 SMD Ceramic capacitor 10V X7R	MuRata	GRM32ER71A226KE15L	VDDOUT Output capacitor
Q	P-Channel SOT-23	Fairchild	SI2333CDS	VDDOUT Output FET
	<u>DA9053 BOOST</u>			
L	4.7 μ H SMD 1.7 A inductor	Taiyo Yuden	NR3015T4R7M	inductor

DA9053 / NXP™ i.MX 6DualLite Applications Processor Example Power Connections

C	10 μ F 0603 SMD Ceramic capacitor 10 V X5R	Panasonic	ECJ-1VB1A106M	Input capacitor
C	2.2 μ F 1206 SMD Ceramic capacitor 25 V X5R	MuRata	GRM31MR71E22 5KA93L	Output capacitor
RefDes	Description	Manufacturer	Manufacturer's Part Number	Notes
C	100 pF 0402 SMD Ceramic capacitor 50 V COG	MuRata	GRM155C1H101 JD01D	Feedback/OVP capacitor
R	0R1 0402 SMD chip resistor	Panasonic	ERJ2BSGR10x	Current sense
R	1 M Ω 0402 SMD chip resistor	Yageo	RC0402FR-071ML	Feedback/OVP #1
R	68 k Ω 0402 SMD chip resistor	Yageo	RC0402FR-0768KL	Feedback/OVP #2
Q	P-Channel SOT-23	ON Semi	NTLJF4156N	FET
	<u>DA9053 LDOs</u>			
C	1 μ F 0402 SMD Ceramic capacitor 16 V X7R	MuRata	GRM155R61A10 5KE15	LDO Input capacitor
C	1 μ F 0402 SMD Ceramic capacitor 16 V X7R	MuRata	GRM155R61A10 5KE15	LDO Input capacitor
C	1 μ F 0402 SMD Ceramic capacitor 10 V X5R	MuRata	GRM155R61A10 5KE15D	LDO1 Output capacitor
C	1 μ F 0402 SMD Ceramic capacitor 10 V X5R	MuRata	GRM155R61A10 5KE15D	LDO2 Output capacitor
C	2.2 μ F 0402 SMD Ceramic capacitor 6.3 V X5R	Kemet	C0402C225M9P AC	LDO3 Output capacitor
C	2.2 μ F 0402 SMD Ceramic capacitor 6.3 V X5R	Kemet	C0402C225M9P AC	LDO4 Output capacitor
C	1 μ F 0402 SMD Ceramic capacitor 10 V X5R	MuRata	GRM155R61A10 5KE15D	LDO5 Output capacitor
C	2.2 μ F 0402 SMD Ceramic capacitor 6.3 V X5R	Kemet	C0402C225M9P AC	LDO6 Output capacitor
C	2.2 μ F 0402 SMD Ceramic capacitor 6.3 V X5R	Kemet	C0402C225M9P AC	LDO7 Output capacitor
C	2.2 μ F 0402 SMD Ceramic capacitor 6.3 V X5R	Kemet	C0402C225M9P AC	LDO8 Output capacitor
C	1 μ F 0402 SMD Ceramic capacitor 10 V X5R	MuRata	GRM155R61A10 5KE15D	LDO9 Output capacitor
C	2.2 μ F 0402 SMD Ceramic capacitor 6.3 V X5R	Kemet	C0402C225M9P AC	LDO10 Output capacitor
C	0.1 μ F 0402 SMD Ceramic capacitor 16 V X7R	MuRata	GRM155R71C10 4KA88D	VDDCORE
	<u>DA9053 SYSTEM DECOUPLING</u>			
C	470 nF 0402 SMD Ceramic capacitor 6.3 V X5R	MuRata	GRM155R61A47 4KE15D	Backup Battery Decoupling capacitor
C	4.7 μ F 0603 SMD Ceramic capacitor 6.3 V X5R	MuRata	GRM188R60J47 5KE19D	VBUS_PROT Decoupling
C	2.2 μ F 0402 SMD Ceramic capacitor 6.3 V X5R	Kemet	C0402C225M9P AC	VBUS Decoupling

DA9053 / NXP™ i.MX 6DualLite Applications Processor Example Power Connections

C	4.7 μ F 0603 SMD Ceramic capacitor 6.3 V X5R	MuRata	GRM188R60J475KE19D	DCIN_PROT Decoupling
C	2.2 μ F 0402 SMD Ceramic capacitor 6.3 V X5R	Kemet	C0402C225M9PAC	DCIN Decoupling
C	10 μ F 0603 SMD Ceramic capacitor 10 V X5R	Panasonic	ECJ-1VB1A106M	VBAT Ball Decoupling
C	10 μ F 0603 SMD Ceramic capacitor 10 V X5R	Panasonic	ECJ-1VB1A106M	VCENTER Ball Decoupling
C	2 x 10 μ F 0603 SMD Ceramic capacitor 10 V X5R	Panasonic	ECJ-1VB1A106M	VDDOUT Decoupling
	<u>DA9053 XTAL</u>			
Y	32.768 kHz CC7VA SM Crystal 9 pF	Golledge	CC7VA-T1A	32kHz XTAL
C	12 pF 0402 SMD Ceramic capacitor 50 V C0G	MuRata	GRM1555C1H120JZ01D	32kHz XTAL CAP
C	12 pF 0402 SMD Ceramic capacitor 50 V C0G	MuRata	GRM1555C1H120JZ01D	32kHz XTAL CAP
	<u>DA9053 REF</u>			
C	0.1 μ F 0402 SMD Ceramic capacitor 16 V X7R	MuRata	GRM155R71C104KA88D	VREF1
C	2.2 μ F 0402 SMD Ceramic capacitor 10 V X5R	MuRata	GRM155R60J225ME15	VDD_REF
R	200 k Ω 0402 SMD chip resistor 1% 0.063 W	Panasonic	ERJ2RKF2003x	IREF
	<u>DA9053 MISCELLANEOUS</u>			
Q	P-Channel CSP1.0 x 1.5mm	TI	CSD25301W1015	VBUS FET
Q	P-Channel CSP1.0 x 1.5mm	TI	CSD25301W1015	DCIN FET
Q	P-Channel SOT23	Vishay	Si2333DS	System Load FET
D	Schottky diode 1 A 20 V SOD323	NXP	BAT760	Charger Buck Schottky Diode
BAT	Lithium Battery (rechargeable) ML414, 1.0 mAh, 3.1 V	Sanyo	ML414, 1.0 mAh, 3.1 V	Backup Battery
R	2.2 k Ω 0402 SMD chip resistor	Yageo	RC0402FR-072K2L	SO Pull-up Resistor
R	2.2 k Ω 0402 SMD chip resistor	Yageo	RC0402FR-072K2L	SK Pull-up Resistor

11 Power Commander™ initialisation file for NXP™ i.MX 6 DualLite applications processor

Four standard OTP variants for the DA9053 have been produced (Table 4). These all support the configuration described in this application note. Variant DA9053-60 provides support for systems that wish to use an external wake-up event such as an nONKEY press to start the system. Variant DA9053-61 provides support for systems that wish to auto-boot as soon as power is applied. Variants DA9053-62 and -63 support the above two configurations where the system has no battery.

DA9053 / NXP™ i.MX 6DualLite Applications Processor Example Power Connections

The initialisation files for these variants are available from the Dialog customer portal or via request to your local Dialog sales office.

The file DA9053-60_iMX6DL_1R2_1D46.ini defines the DA9053 power-up sequence (Figure 4) and default configuration to power the NXP™ i.MX 6 DualLite applications processor.

Table 4: DA9053 standard variants

Variant	Battery	Autoboot
DA9053-60	Y	N
DA9053-61	Y	Y
DA9053-62	N	N
DA9053-63	N	Y

12 Ordering information

To order the specific variants for this configuration, substitute the variant number (60, 61, 62 or 63) for the xx in the part numbered listed in Table 5.

Note other quantities are available through distribution channels.

Table 5: DA9053 order codes

Part number	Package	Shipment	Pack quantity
DA9053-xxC51	7 x 7 169-bump BGA Pb-free/green	Tray	260
DA9053-xxC52	7 x 7 169-bump BGA Pb-free/green	T&R	3,000
DA9053-xxHA1	11 x 11 169-bump BGA Pb-free/green	Tray	176
DA9053-xxHA2	11 x 11 169-bump BGA Pb-free/green	T&R	2000

13 Suspend and Resume operation

The configuration described in this application note provides support for Suspend and Resume operation. The DA9053 uses the HW signal PMIC_STBY_REQ to enter a low power Suspend state. The regulators of the DA9053 can be pre-configured via SW to switch off, remain on or drop to a retention level during Suspend. The regulators are automatically reset to their power-up defaults when the Resume operation is triggered by a valid wake-up event. Application note 'AN-PM-007 Suspend and Resume.pdf' provides more details of this functionality.

14 Host communication

The DA9053 offers two options for communication between the host and the PMIC. The 4-wire (SPI) interface is the recommended option as it provides point to point communication without the potential for bus contention or increased latency. The DA9053 also supports a 2-wire interface that is generally compatible with I²C. For designs planning to use the 2-wire interface, especially where Suspend and Resume functionality is required, please review your implementation with a member of

DA9053 / NXP™ i.MX 6DualLite Applications Processor Example Power Connections

the Dialog Applications Team as care must be taken with the allocation and control of the I/O rails to achieve the lowest power consumption in Suspend.

15 Additional supplies

The NXP™ SABRE board design utilises two additional 5 V rails. These are PMIC_5V and AUX_5V. These rails are provided by a boost convertor powered from the battery/input rail. These additional rails may be required depending on the system requirements. These rails need to be provided by an external boost convertor.

The DA9053 does not include a regulator capable of providing the peak current of the NXP™ SABRE board GEN_3V3 rail. In the design described in this application note an external regulator has been used. This external regulator is sequenced by the DA9053 by using the GP_FB2 signal to enable the external regulator. Depending on the current requirements for a particular design, it may be possible to use multiple LDOs from the DA9053 to provide the 3V3 rail. In larger designs, an external regulator may be required. For efficiency reasons it is recommended to select a suitably-sized buck regulator.

16 Battery-less operation

In the case of a system operating from either an external supply or from an external regulator supplied from a multi-cell battery solution, there are some additional optimisations that can be made, as follows:

- One of the two variants designed for battery-less operation should be used
- The 5 V rails should be provided directly from the input supply to eliminate the requirement of an external boost
- The DA9053 Charger Buck can supply ~1.9 A to the VDDOUT rail. Care should be taken not to overload this rail
- To reduce the load on VDDOUT and possibly improve efficiency, the external buck chosen for the GEN_3V3 rail can be powered directly from the input supply. This regulator would still be sequenced via the use of the GP_FB2 enable signal
- Further efficiency could be gained by supplying some of the LDOs from a buck. This could be either one of the DA9053 Bucks or the external buck providing GEN_3V3.

17 Driver support

The Linux drivers for the device are provided as part of a BSP patch release from Dialog Semiconductor.

This release patches an existing Android BSP for the NXP™ MCIMX6DL-SDP platform with support for a Dialog DA9053 power management and audio IC.

The driver supports provide features of the device within the standard frameworks offered by the Linux kernel. Please refer to the MCIMX6DL-SDP DA9053 BSP documentation for more information on the requirements and dependencies.

This driver release for the MCIMX6DL-SDP DA9053 BSP was based upon an existing Linux kernel driver for the DA9052/3 PMIC. The latest version of this driver is found in the Linux kernel.

For more detailed advice on support for your particular configuration please contact your local Dialog sales office.

DA9053 / NXP™ i.MX 6DualLite Applications Processor Example Power Connections

18 Additional collateral

For a DA9053 / i.MX 6DualLite design, this document is supplemented by the following information:

- DA9053 Configuration Schematic (44-179-115-09-B1.pdf): this schematic shows the required connectivity for the DA9053 and is effectively a replacement for the PMIC page of the NXP™ SABRE board schematic. All of the required connections have been named to match the net names on the NXP™ schematic.
- DA9053 Reference Board: schematic and reference layout

These documents, along with additional application notes and design guides, are available from the Dialog customer portal which is accessible from the [Dialog web site](#). Please contact your local Dialog Applications representative for details.

19 Conclusions

This application note has detailed one possible configuration for the DA9053 PMIC to support the NXP™ i.MX6 DualLite applications processor. This configuration closely matches the NXP™ SABRE board design.

With its highly configurable design, the DA9053 is well suited to nearly all applications of the i.MX6 DualLite processor.

DA9053 / NXP™ i.MX 6DualLite Applications
Processor Example Power Connections**Revision history**

Revision	Date	Description
0.1	24-Oct-2013	Initial version.
1.0	08-Oct-2015	Update to latest template. Minor text updates.
1.1	18-Feb-2016	Minor text updates.

DA9053 / NXP™ i.MX 6DualLite Applications Processor Example Power Connections

Status definitions

Status	Definition
DRAFT	The content of this document is under review and subject to formal approval, which may result in modifications or additions.
APPROVED or unmarked	The content of this document has been approved for publication.

Disclaimer

Information in this document is believed to be accurate and reliable. However, Dialog Semiconductor does not give any representations or warranties, expressed or implied, as to the accuracy or completeness of such information. Dialog Semiconductor furthermore takes no responsibility whatsoever for the content in this document if provided by any information source outside of Dialog Semiconductor.

Dialog Semiconductor reserves the right to change without notice the information published in this document, including without limitation the specification and the design of the related semiconductor products, software and applications.

Applications, software, and semiconductor products described in this document are for illustrative purposes only. Dialog Semiconductor makes no representation or warranty that such applications, software and semiconductor products will be suitable for the specified use without further testing or modification. Unless otherwise agreed in writing, such testing or modification is the sole responsibility of the customer and Dialog Semiconductor excludes all liability in this respect.

Customer notes that nothing in this document may be construed as a license for customer to use the Dialog Semiconductor products, software and applications referred to in this document. Such license must be separately sought by customer with Dialog Semiconductor.

All use of Dialog Semiconductor products, software and applications referred to in this document are subject to Dialog Semiconductor's [Standard Terms and Conditions of Sale](#), unless otherwise stated.

© Dialog Semiconductor. All rights reserved.

RoHS Compliance

Dialog Semiconductor complies to European Directive 2001/95/EC and from 2 January 2013 onwards to European Directive 2011/65/EU concerning Restriction of Hazardous Substances (RoHS/RoHS2). Dialog Semiconductor's statement on RoHS can be found on the customer portal <https://support.diasemi.com/>. RoHS certificates from our suppliers are available on request.

Contacting Dialog Semiconductor

United Kingdom (Headquarters)

Dialog Semiconductor (UK) LTD
Phone: +44 1793 757700

Germany

Dialog Semiconductor GmbH
Phone: +49 7021 805-0

The Netherlands

Dialog Semiconductor B.V.
Phone: +31 73 640 8822

Email:

enquiry@diasemi.com

North America

Dialog Semiconductor Inc.
Phone: +1 408 845 8500

Japan

Dialog Semiconductor K. K.
Phone: +81 3 5425 4567

Taiwan

Dialog Semiconductor Taiwan
Phone: +886 281 786 222

Web site:

www.dialog-semiconductor.com

Singapore

Dialog Semiconductor Singapore
Phone: +65 64 8499 29

Hong Kong

Dialog Semiconductor Hong Kong
Phone: +852 3769 5200

Korea

Dialog Semiconductor Korea
Phone: +82 2 3469 8200

China (Shenzhen)

Dialog Semiconductor China
Phone: +86 755 2981 3669

China (Shanghai)

Dialog Semiconductor China
Phone: +86 21 5424 9058

IMPORTANT NOTICE AND DISCLAIMER

RENESAS ELECTRONICS CORPORATION AND ITS SUBSIDIARIES (“RENESAS”) PROVIDES TECHNICAL SPECIFICATIONS AND RELIABILITY DATA (INCLUDING DATASHEETS), DESIGN RESOURCES (INCLUDING REFERENCE DESIGNS), APPLICATION OR OTHER DESIGN ADVICE, WEB TOOLS, SAFETY INFORMATION, AND OTHER RESOURCES “AS IS” AND WITH ALL FAULTS, AND DISCLAIMS ALL WARRANTIES, EXPRESS OR IMPLIED, INCLUDING, WITHOUT LIMITATION, ANY IMPLIED WARRANTIES OF MERCHANTABILITY, FITNESS FOR A PARTICULAR PURPOSE, OR NON-INFRINGEMENT OF THIRD-PARTY INTELLECTUAL PROPERTY RIGHTS.

These resources are intended for developers who are designing with Renesas products. You are solely responsible for (1) selecting the appropriate products for your application, (2) designing, validating, and testing your application, and (3) ensuring your application meets applicable standards, and any other safety, security, or other requirements. These resources are subject to change without notice. Renesas grants you permission to use these resources only to develop an application that uses Renesas products. Other reproduction or use of these resources is strictly prohibited. No license is granted to any other Renesas intellectual property or to any third-party intellectual property. Renesas disclaims responsibility for, and you will fully indemnify Renesas and its representatives against, any claims, damages, costs, losses, or liabilities arising from your use of these resources. Renesas' products are provided only subject to Renesas' Terms and Conditions of Sale or other applicable terms agreed to in writing. No use of any Renesas resources expands or otherwise alters any applicable warranties or warranty disclaimers for these products.

(Disclaimer Rev.1.01)

Corporate Headquarters

TOYOSU FORESIA, 3-2-24 Toyosu,
Koto-ku, Tokyo 135-0061, Japan
www.renesas.com

Trademarks

Renesas and the Renesas logo are trademarks of Renesas Electronics Corporation. All trademarks and registered trademarks are the property of their respective owners.

Contact Information

For further information on a product, technology, the most up-to-date version of a document, or your nearest sales office, please visit www.renesas.com/contact-us/.