

# Application Note

## Renesas R-Car E2 Platform for Automotive Infotainment

AN-PM-047

### Abstract

*The R-Car E2 System-on-Chip (SoC) based platform from Renesas is part of a family of platforms (R-Car series) for automotive infotainment systems. The E2 is aimed at the entry-level segment and is optimised for integrated dashboards.*

*The E2 series includes two main platforms: the ALT and the SILK versions. Both platforms feature the DA9063 as the PMIC (Power Management IC) used to power and supervise the complete system. The ALT version differs from the SILK in that it does not use the DDR termination feature of the DA9063.*

*Through a description of the general system configuration, power capabilities and requirements and an overview of the component interconnections, it will be shown that the DA9063 is highly suited as the R-Car power management system solution for E2 platforms.*

---

## Renesas R-Car E2 Platform for Automotive Infotainment

### Contents

<b>Abstract</b> .....	<b>1</b>
<b>Contents</b> .....	<b>2</b>
<b>Figures</b> .....	<b>2</b>
<b>Tables</b> .....	<b>2</b>
<b>1 Introduction</b> .....	<b>3</b>
<b>2 Renesas R-Car E2 SoC Description</b> .....	<b>3</b>
<b>3 DA9063 Description</b> .....	<b>4</b>
<b>4 R-Car E2 SoC Power Requirements</b> .....	<b>5</b>
<b>5 R-Car E2 (ALT) Power Supply Tree Diagram (Top Level)</b> .....	<b>6</b>
<b>6 DA9063 PMIC and R-Car E2-ALT SoC Interconnections Diagram</b> .....	<b>7</b>
6.1 Cold Boot Sequence for E2 (ALT) .....	8
<b>7 DA9063 PMIC and R-Car E2-SILK SoC Interconnections Diagram</b> .....	<b>9</b>
7.1 Cold Boot Sequence for E2 (SILK) .....	10
<b>8 Platforms Resource References and Ordering Information<sup>1</sup></b> .....	<b>11</b>
<b>9 DA9063-63HK2-A (ALT) – Detailed Register Description</b> .....	<b>12</b>
<b>10 DA9063-65HK2-A (SILK) – Detailed Register Description</b> .....	<b>17</b>
<b>Revision History</b> .....	<b>22</b>

### Figures

Figure 1: R-Car E2 System Block Diagram.....	3
Figure 2: DA9063 System Block Diagram.....	4
Figure 3: R-Car E2 (ALT) Power-Up Sequence .....	5
Figure 4: R-Car E2 Power Tree.....	6
Figure 5: DA9063 – R-Car E2 (ALT) Interconnections.....	7
Figure 6: DA9063-63HK2-A Power-Up Sequence (ALT) .....	8
Figure 7: DA9063 – R-Car E2 (SILK) Interconnections .....	9
Figure 8: DA9063-65HK2-A Power-Up Sequence (SILK).....	10

### Tables

Table 1: DA9063-63HK2-A (SILK) Register Settings.....	12
Table 2: DA9063-65HK2-A (SILK) Register Settings.....	17

## Renesas R-Car E2 Platform for Automotive Infotainment

### 1 Introduction

This document describes how to interconnect the DA9063 Power Management IC (PMIC) to the Renesas R-Car E2 SoC. The DA9063 is a highly integrated chip that supports Dynamic Voltage Control (DVC) technology, enabling significant power saving: this feature supports the DVFS (Dynamic Voltage and Frequency Scaling) technology that is used by many processors. As a result of its highly integrated features, the DA9063 significantly reduces the overall system cost and size compared to a discrete solution. This application note addresses only the power supply related features: discussion of other features of the optimized PMIC is beyond the scope of this document. For further information on the DA9063 please refer to the datasheet available via your local Dialog sales office. For more information about Renesas R-Car E2 SoC, please refer to the Renesas website:

[http://www.renesas.eu/applications/automotive/cis/cis\\_highend/rcar\\_e2/index.jsp](http://www.renesas.eu/applications/automotive/cis/cis_highend/rcar_e2/index.jsp)

### 2 Renesas R-Car E2 SoC Description

Figure 1 shows a typical system block diagram of an R-Car E2 SoC application. It includes an embedded ARM®Cortex™A7 Dual Core and an SH4A core, both requiring power management that is readily achieved using the Dialog DA9063.

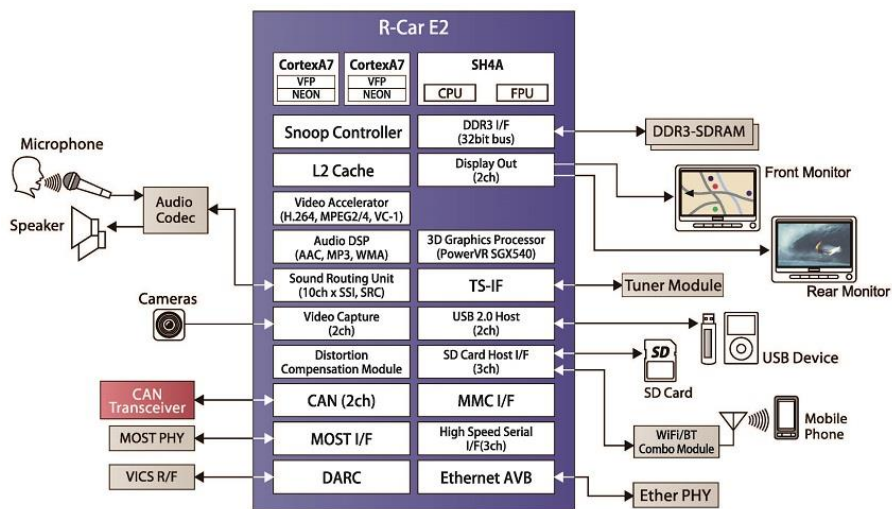

Figure 1: R-Car E2 System Block Diagram

## Renesas R-Car E2 Platform for Automotive Infotainment

### 3 DA9063 Description

The DA9063 is a high current system PMIC suitable for dual and quad core processors that require up to 5 A core processor supply. The DA9063 contains:

- 6 x DC-DC buck converters designed to use small external 1  $\mu$ H inductors, capable of supplying in total up to 12 A continuous output (0.3 – 3.3 V). The buck converters do not require external Schottky diodes; they dynamically optimize their efficiency depending on the load current using an Automatic Sleep Mode (ASM) and incorporate pin and software controlled Dynamic Voltage Control (DVC) to support processor load adaptive adjustment of the supply voltage. In addition BuckPro includes the facility to implement VTT memory bus termination.
- 11 x SmartMirror™ programmable low dropout (LDO) regulators rated up to 300 mA. All support remote capacitor placement and can operate from low 1.5/1.8 V input supplies. This allows these LDOs to be cascaded with (i.e. supplied by) a suitable buck supply to improve overall system efficiency.

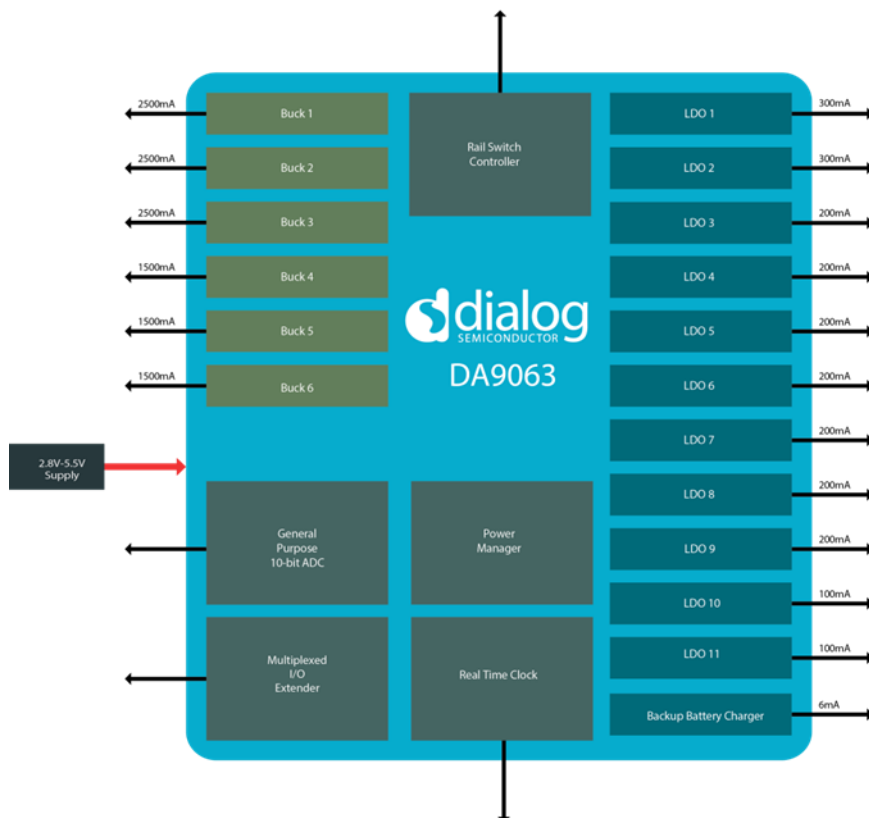

Figure 2: DA9063 System Block Diagram

## Renesas R-Car E2 Platform for Automotive Infotainment

### 4 R-Car E2 SoC Power Requirements

Several power domains in the R-Car E2 SoC platform require precise voltage management for reliable operation of the system. The primary power domains are:

- VDD (1.0V): power supply for internal ARM cores (ARM® Cortex TM-A7 Dual Core, SH4A core)
- VCCQ (3.3V/ 1.8V): supplies for I/Os
- VDDR (1.5V/1.35V): supplies for DDR pre-drivers

Other supplies might be required for the DDR3 memory system, peripherals, I/O interfaces, USB, etc. Additionally, the system power management must comply with the specific power-up and power-down sequence guidelines for the R-Car SoC [Figure 3](#).

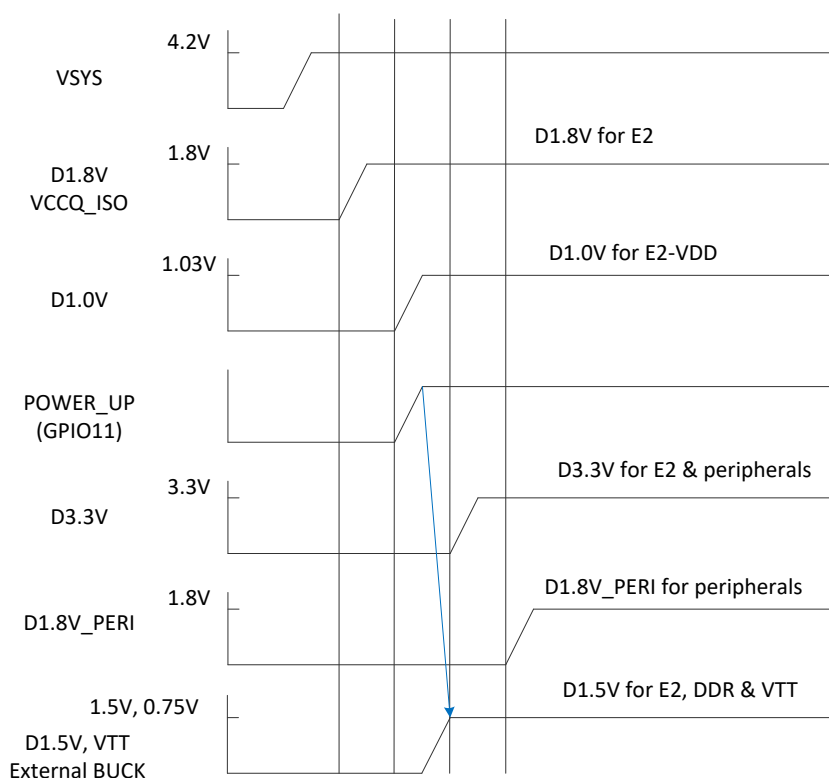

**Figure 3: R-Car E2 (ALT) Power-Up Sequence**

Renesas R-Car E2 Platform for Automotive Infotainment

5 R-Car E2 (ALT) Power Supply Tree Diagram (Top Level)

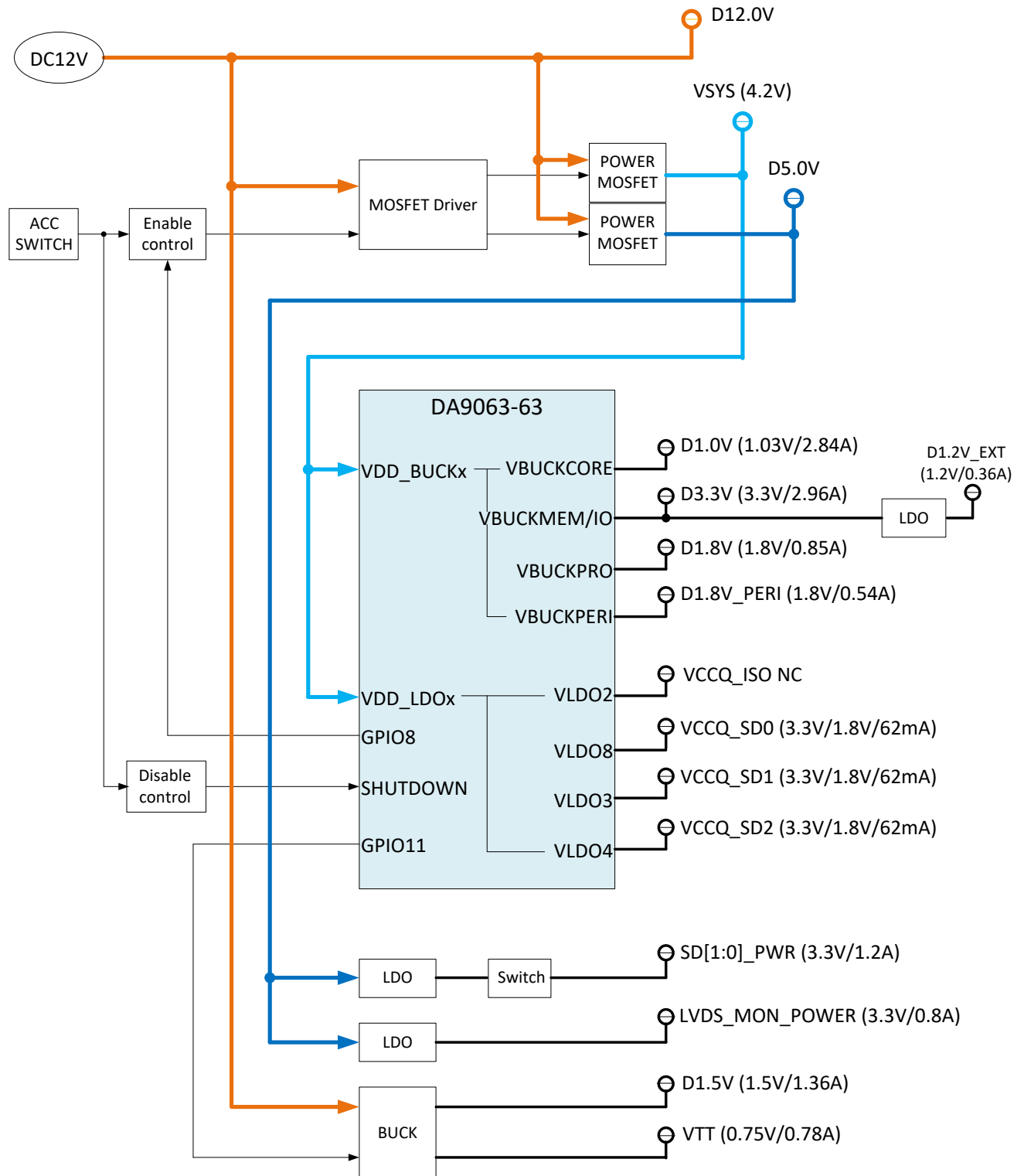

Figure 4: R-Car E2 Power Tree

Renesas R-Car E2 Platform for Automotive Infotainment

6 DA9063 PMIC and R-Car E2-ALT SoC Interconnections Diagram

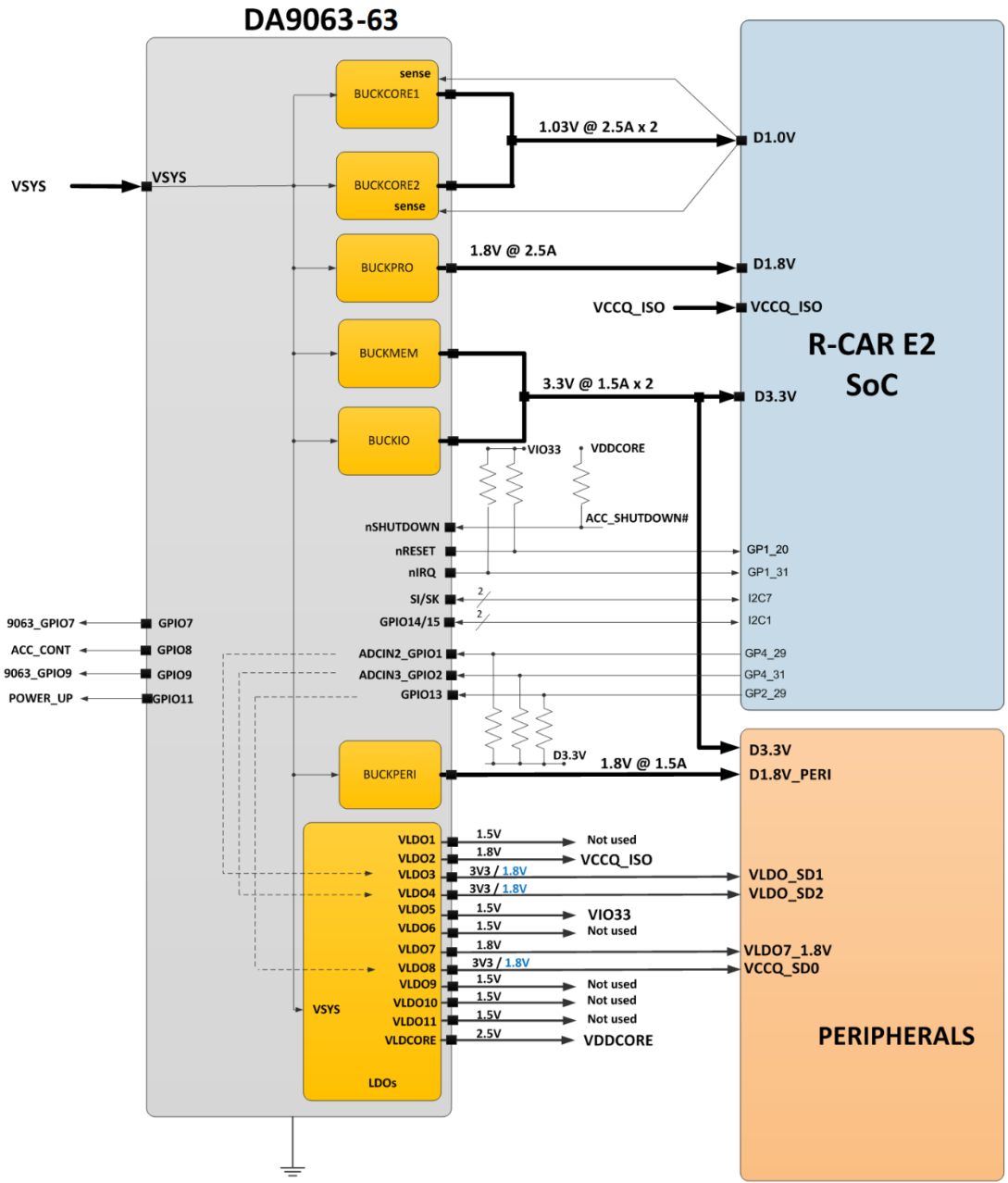

Figure 5: DA9063 – R-Car E2 (ALT) Interconnections

Renesas R-Car E2 Platform for Automotive Infotainment

6.1 Cold Boot Sequence for E2 (ALT)

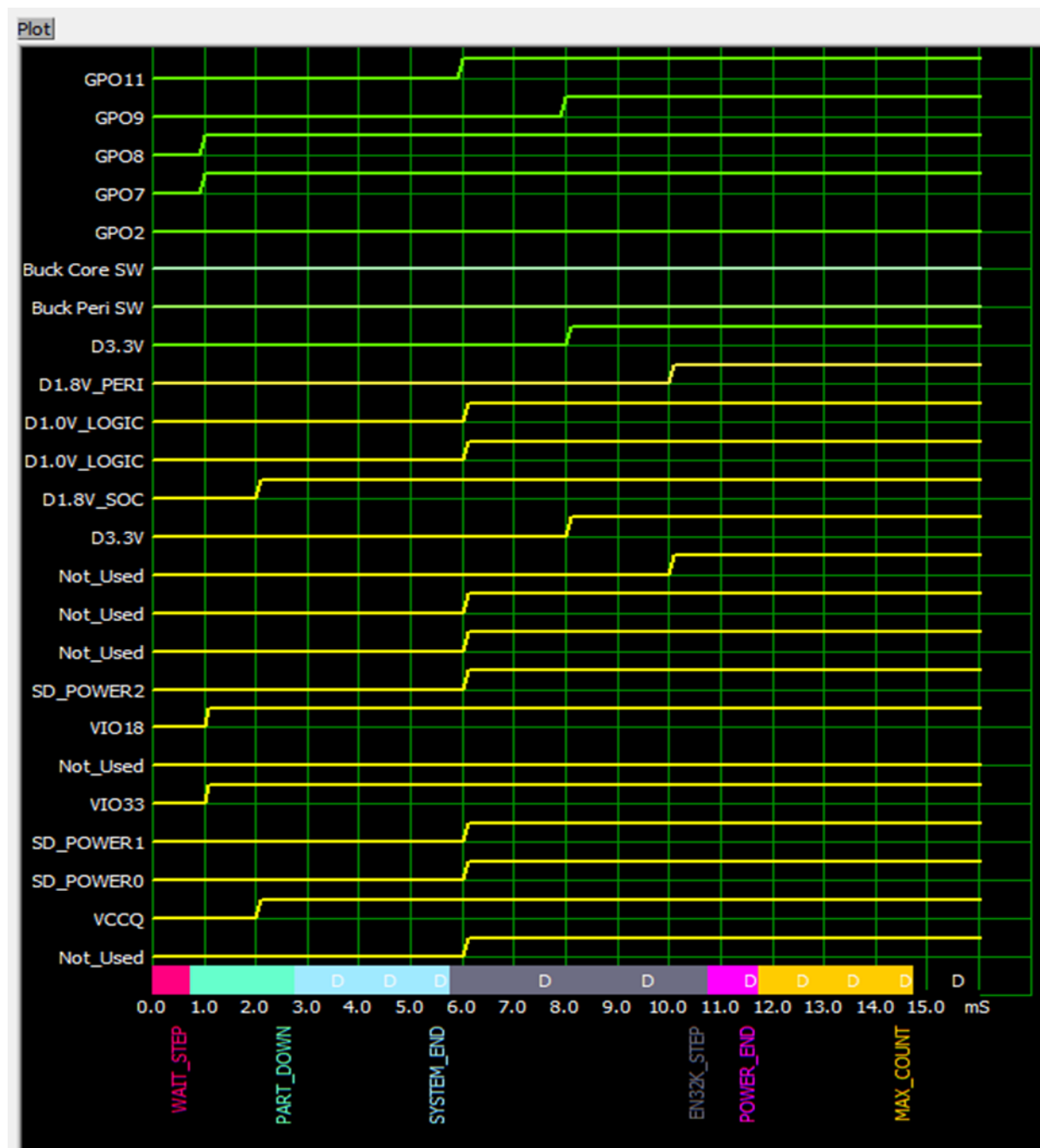

Figure 6: DA9063-63HK2-A Power-Up Sequence (ALT)

Renesas R-Car E2 Platform for Automotive Infotainment

## 7 DA9063 PMIC and R-Car E2-SILK SoC Interconnections Diagram

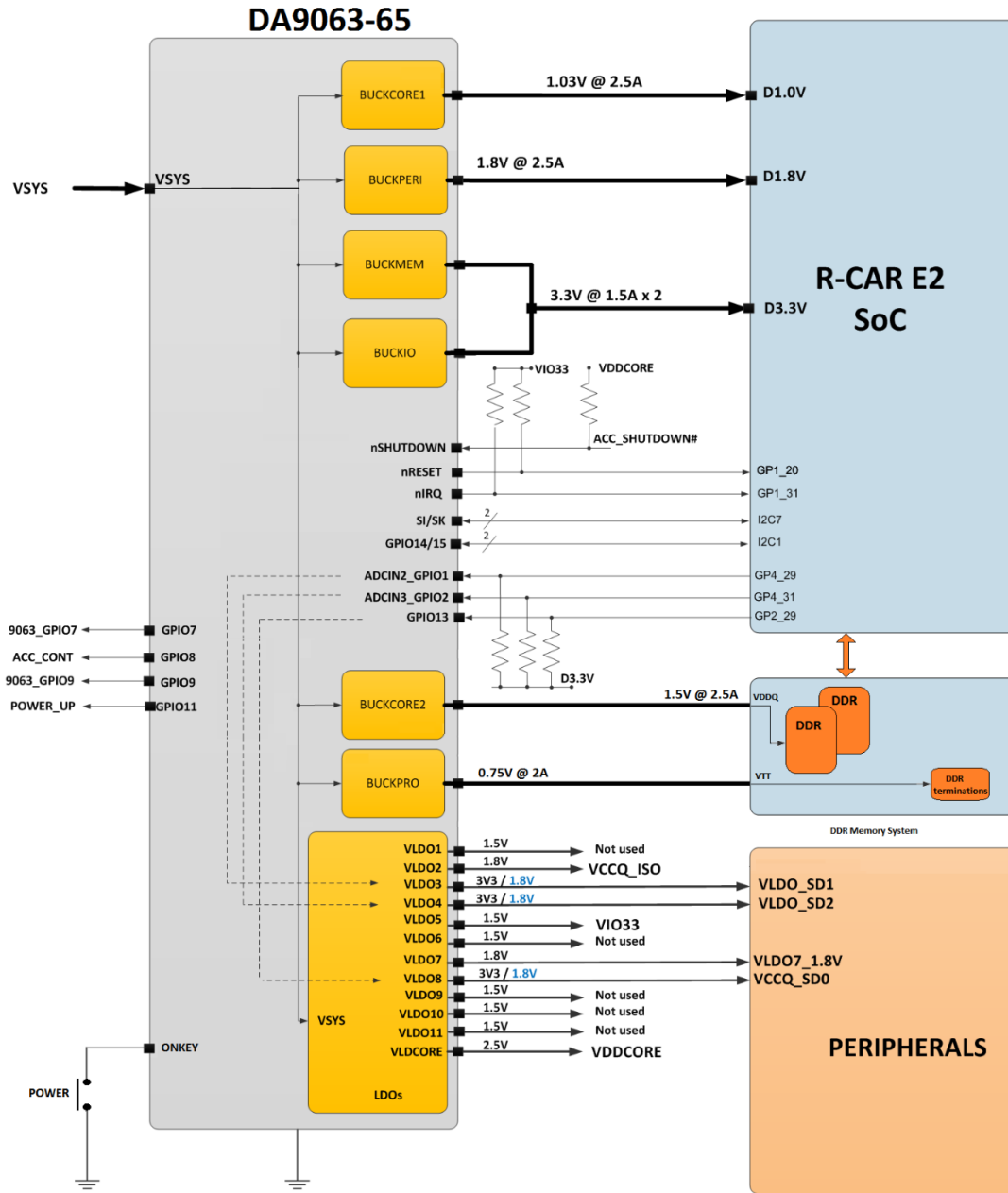

Figure 7: DA9063 – R-Car E2 (SILK) Interconnections

Renesas R-Car E2 Platform for Automotive Infotainment

7.1 Cold Boot Sequence for E2 (SILK)

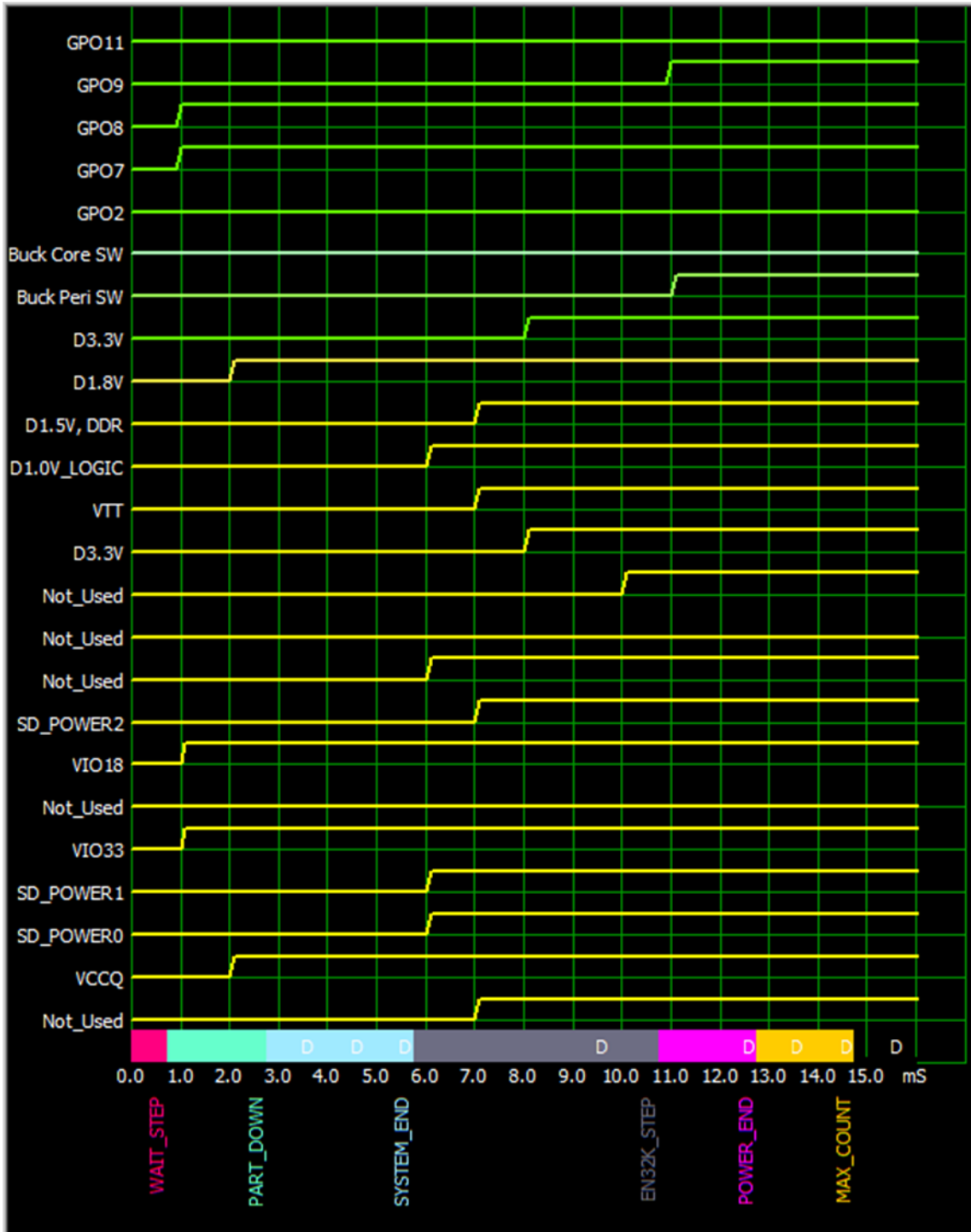

Figure 8: DA9063-65HK2-A Power-Up Sequence (SILK)

## Renesas R-Car E2 Platform for Automotive Infotainment

### 8 Platforms Resource References and Ordering Information<sup>1</sup>

Platform name: *R-Car E2*

Schematic: *ALT\_Board circuit\_rev016*

Board name: *R-CarE2 System Evaluation Board (ALT)*

OTP variant: *DA9063-63HK2-A*<sup>2</sup>

Platform name: *R-Car E2\_LCB*

Schematic: *SILK\_SCHEMATIC1\_POWER (DA9063)*

Board name: *R-CarE2 System Evaluation Board (SILK)*

OTP variant: *DA9063-65HK2-A*<sup>2</sup>

Please refer to AN-PM-010\_Layout\_Guidelines, available from the Dialog website, for Dialog recommended PCB layout guidelines.

Please refer to AN-PM-058 Shared IRQ Line Considerations, available from the Dialog website, for considerations regarding IRQ line sharing.

NOTE
<p><sup>1</sup> For schematic availability, please contact your local Renesas representative.</p> <p><sup>2</sup> Please contact your local Dialog representative for the most current recommended OTP.</p>

## Renesas R-Car E2 Platform for Automotive Infotainment

### 9 DA9063-63HK2-A (ALT) – Detailed Register Description

#### Key settings

- Normal start-up
- Voltage monitor
- Autoboot
- 32kHz clock output
- 2-wire control interface, standard speed, fast mode plus
- Buck Mem & Buck IO merged mode
- 2-wire control interface, FM+ (Fast Mode Plus)
- Eco mode enabled
- RTC enabled
- LDO3, 4, 8 GPIO controlled by host

**Table 1: DA9063-63HK2-A (SILK) Register Settings**

Register Address	Function	Register Value	Register Description
0x00A	IRQ_MASK_A	0x00	nONKEY, RTC, and some status IRQ masks
0x00B	IRQ_MASK_B	0x01	Charger wakeup and temperature, current or voltage IRQ masks
0x00C	IRQ_MASK_C	0x00	GPI7-0 and ADCIN1-3 IRQ masks
0x00D	IRQ_MASK_D	0x01	GPI15-8 and external control signal IRQ masks
0x00E	CONTROL_A	0x03	PSM target status, companion charger control
0x00F	CONTROL_B	0x09	Power down / up signalling
0x010	CONTROL_C	0x5B	Debounce, boot, DVC and DEF_SUPPLY control
0x011	CONTROL_D	0x68	Watchdog and LED blink control
0x012	CONTROL_E	0x0C	RTC, eco-mode, feedback pins, V_LOCK
0x013	CONTROL_F	0x00	Watchdog reset, shutdown and wake-up
0x014	PD_DIS	0x40	Disable / pause blocks when below the PSS sequencer PD_DIS slot
0x015	GPIO_0_1	0x54	GPIO 0 and 1 control
0x016	GPIO_2_3	0x75	GPIO 2 and 3 control
0x017	GPIO_4_5	0x77	GPIO 4 and 5 control
0x018	GPIO_6_7	0x67	GPIO 6 and 7 control
0x019	GPIO_8_9	0x66	GPIO 8 and 9 control
0x01A	GPIO_10_11	0x67	GPIO 10 and 11 control
0x01B	GPIO_12_13	0x57	GPIO 12 and 13 control
0x01C	GPIO_14_15	0x66	GPIO 14 and 15 control registers
0x01D	GPIO_MODE0_7	0xFE	GPIO 0-7 mode control
0x01E	GPIO_MODE8_15	0xFF	GPIO 8-15 mode control
0x01F	SWITCH_CONT	0xB0	Rail switches
0x020	BCORE2_CONT	0x00	BUCK CORE2 Control

## Renesas R-Car E2 Platform for Automotive Infotainment

Register Address	Function	Register Value	Register Description
0x021	BCORE1_CONT	0x00	BUCK CORE1 Control
0x022	BPRO_CONT	0x00	BUCK PRO Control
0x023	BMEM_CONT	0x00	BUCK MEM Control
0x024	BIO_CONT	0x00	BUCK IO Control
0x025	BPERI_CONT	0x00	BUCK PERI Control
0x026	LDO1_CONT	0x00	LDO1 Control
0x027	LDO2_CONT	0x08	LDO2 Control
0x028	LDO3_CONT	0x20	LDO3 Control
0x029	LDO4_CONT	0x40	LDO4 Control
0x02A	LDO5_CONT	0x00	LDO5 Control
0x02B	LDO6_CONT	0x00	LDO6 Control
0x02C	LDO7_CONT	0x00	LDO7 Control
0x02D	LDO8_CONT	0x60	LDO8 Control
0x02E	LDO9_CONT	0x00	LDO9 Control
0x02F	LDO10_CONT	0x00	LDO10 Control
0x030	LDO11_CONT	0x00	LDO10 Control
0x031	SUPPLIES	0x00	Vibrator output level
0x032	DVC_1	0x00	Dynamic voltage control
0x033	DVC_2	0x00	Dynamic voltage control
0x034	ADC_MAN	0x04	ADC manual and automatic measurement control
0x035	ADC_CONT	0x00	ADC automatic measurement control
0x036	VSYS_MON	0x40	
0x083	ID_2_1	0x26	PSS sequence control
0x084	ID_4_3	0x66	PSS sequence control
0x085	ID_6_5	0x01	PSS sequence control
0x086	ID_8_7	0x61	PSS sequence control
0x087	ID_10_9	0x66	PSS sequence control
0x088	ID_12_11	0x5A	PSS sequence control
0x089	ID_14_13	0x66	PSS sequence control
0x08A	ID_16_15	0x82	PSS sequence control
0x08B	ID_18_17	0xA8	PSS sequence control
0x08C	ID_20_19	0x00	PSS sequence control
0x08D	ID_22_21	0x00	PSS sequence control
0x08E	ID_24_23	0x01	PSS sequence control
0x08F	ID_26_25	0x01	PSS sequence control
0x090	ID_28_27	0x08	PSS sequence control
0x091	ID_30_29	0x06	PSS sequence control
0x092	ID_32_31	0xA0	PSS sequence control

## Renesas R-Car E2 Platform for Automotive Infotainment

Register Address	Function	Register Value	Register Description
0x095	SEQ_A	0xB5	PSS sequencer slot end points
0x096	SEQ_B	0x2E	PSS sequencer slot end points
0x097	WAIT	0x54	Power sequencer wait cycle
0x098	EN_32K	0xE8	RTC clocking control
0x099	RESET	0x41	Reset timer control
0x09A	BUCK_ILIM_A	0xFF	Buck current limit
0x09B	BUCK_ILIM_B	0xFF	Buck current limit
0x09C	BUCK_ILIM_C	0xFF	Buck current limit
0x09D	BCORE2_CFG	0x00	BUCKCORE2 control
0x09E	BCORE1_CFG	0x00	BUCKCORE1 control
0x09F	BPRO_CFG	0x21	BUCKPRO control
0x0A0	BIO_CFG	0x01	BUCKPRO control
0x0A1	BMEM_CFG	0x01	BUCKMEM control
0x0A2	BPERI_CFG	0x01	BUCKPERI control
0x0A3	VBCORE2_A	0x49	BUCKCORE2 voltage A
0x0A4	VBCORE1_A	0x49	BUCKCORE1 voltage A
0x0A5	VBPRO_A	0x7F	BUCKPRO voltage A
0x0A6	VBMEM_A	0x7D	BUCKMEM voltage A
0x0A7	VBIO_A	0x7D	BUCKIO voltage A
0x0A8	VBPERI_A	0x32	BUCKPERI voltage A
0x0A9	VLDO1_A	0xAD	LDO* voltage A
0x0AA	VLDO2_A	0x3C	LDO* voltage A
0x0AB	VLDO3_A	0x78	LDO* voltage A
0x0AC	VLDO4_A	0x78	LDO* voltage A
0x0AD	VLDO5_A	0x32	LDO* voltage A
0x0AE	VLDO6_A	0xB2	LDO* voltage A
0x0AF	VLDO7_A	0x14	LDO* voltage A
0x0B0	VLDO8_A	0x32	LDO* voltage A
0x0B1	VLDO9_A	0xB2	LDO* voltage A
0x0B2	VLDO10_A	0xB2	LDO* voltage A
0x0B3	VLDO11_A	0x94	LDO* voltage A
0x0B4	VBCORE2_B	0x46	BUCKCORE2 voltage B
0x0B5	VBCORE1_B	0x46	BUCKCORE1 voltage B
0x0B6	VBPRO_B	0x7F	BUCKPRO voltage B
0x0B7	VBMEM_B	0x7D	BUCKMEM voltage B
0x0B8	VBIO_B	0x7D	BUCKIO voltage B
0x0B9	VBPERI_B	0x32	BUCKPERI voltage B
0x0BA	VLDO1_B	0x9E	LDO* voltage B

## Renesas R-Car E2 Platform for Automotive Infotainment

Register Address	Function	Register Value	Register Description
0x0BB	VLDO2_B	0x3C	LDO* voltage B
0x0BC	VLDO3_B	0x2D	LDO* voltage B
0x0BD	VLDO4_B	0x2D	LDO* voltage B
0x0BE	VLDO5_B	0xB2	LDO* voltage B
0x0BF	VLDO6_B	0xB2	LDO* voltage B
0x0C0	VLDO7_B	0x94	LDO* voltage B
0x0C1	VLDO8_B	0x14	LDO* voltage B
0x0C2	VLDO9_B	0xB2	LDO* voltage B
0x0C3	VLDO10_B	0xB2	LDO* voltage B
0x0C4	VLDO11_B	0x94	LDO* voltage B
0x0C5	BBAT_CONT	0x00	Backup battery charger
0x0C6	GPO11_LED	0x00	High power GPO PWM
0x0C7	GPO14_LED	0x00	High power GPO PWM
0x0C8	GPO15_LED	0x00	High power GPO PWM
0x0C9	ADC_CFG	0xE0	ADC automatic measurement control
0x0CA	AUTO1_HIGH	0x00	ADC measurement thresholds
0x0CB	AUTO1_LOW	0x00	ADC measurement thresholds
0x0CC	AUTO2_HIGH	0x00	ADC measurement thresholds
0x0CD	AUTO2_LOW	0x00	ADC measurement thresholds
0x0CE	AUTO3_HIGH	0x00	ADC measurement thresholds
0x0CF	AUTO3_LOW	0x00	ADC measurement thresholds
0x105	INTERFACE	0xB9	Host interfaces
0x106	CONFIG_A	0xA6	Host interfaces and other IOs
0x107	CONFIG_B	0x16	VDD_FAULT comparator
0x108	CONFIG_C	0x50	Buck duty cycle and clock polarity
0x109	CONFIG_D	0x00	
0x10A	CONFIG_E	0x3F	BUCK and rail switch default settings
0x10B	CONFIG_F	0x00	LDO default and bypass mode settings
0x10C	CONFIG_G	0xDE	LDO default settings
0x10D	CONFIG_H	0xF8	
0x10E	CONFIG_I	0x04	
0x10F	CONFIG_J	0xCA	
0x110	CONFIG_K	0x00	GPIO pull resistors
0x111	CONFIG_L	0x20	GPIO pull resistors
0x112	CONFIG_M	0x00	
0x113	CONFIG_N	0x00	
0x114	MON_REG_1	0xCE	
0x115	MON_REG_2	0x00	

## Renesas R-Car E2 Platform for Automotive Infotainment

Register Address	Function	Register Value	Register Description
0x116	MON_REG_3	0x00	
0x117	MON_REG_4	0xD4	
0x121	GP_ID_0	0x02	
0x122	GP_ID_1	0x00	
0x123	GP_ID_2	0x00	
0x124	GP_ID_3	0x00	
0x125	GP_ID_4	0x00	
0x126	GP_ID_5	0x00	
0x127	GP_ID_6	0x00	
0x128	GP_ID_7	0x00	
0x129	GP_ID_8	0x00	
0x12A	GP_ID_9	0x00	
0x12B	GP_ID_10	0x00	
0x12C	GP_ID_11	0x00	
0x12D	GP_ID_12	0x00	
0x12E	GP_ID_13	0x00	
0x12F	GP_ID_14	0x00	
0x130	GP_ID_15	0x00	
0x131	GP_ID_16	0x00	
0x132	GP_ID_17	0x00	
0x133	GP_ID_18	0x00	
0x134	GP_ID_19	0x00	
0x183	CUSTOMER_ID	0x00	Chip ID
0x184	CONFIG_ID	0x63	Customer ID

## Renesas R-Car E2 Platform for Automotive Infotainment

### 10 DA9063-65HK2-A (SILK) – Detailed Register Description

#### Key Settings

- Normal start-up
- Voltage monitor
- Power-on externally controlled by ONKEY button
- 32kHz clock output
- Buck Mem & Buck IO merged-mode
- 2-wire control interface, standard speed, fast mode plus
- Eco mode enabled
- RTC enabled
- LDO3, 4, 8 GPIO controlled by host
- Buck PRO VTT Mode enabled for DDR3 support
- VTTR reference for DDR3 enabled

**Table 2: DA9063-65HK2-A (SILK) Register Settings**

Register Address	Function	Register Value	Register Description
0x00A	IRQ_MASK_A	0x06	nONKEY, RTC, and some status IRQ masks
0x00B	IRQ_MASK_B	0xDF	Charger wakeup and temperature, current or voltage IRQ masks
0x00C	IRQ_MASK_C	0xFF	GPIO7-0 and ADCIN1-3 IRQ masks
0x00D	IRQ_MASK_D	0xFF	GPIO15-8 and external control signal IRQ masks
0x00E	CONTROL_A	0x83	PSM target status, companion charger control
0x00F	CONTROL_B	0x09	Power down / up signalling
0x010	CONTROL_C	0x53	Debounce, boot, DVC and DEF_SUPPLY control
0x011	CONTROL_D	0x68	Watchdog and LED blink control
0x012	CONTROL_E	0x0C	RTC, eco-mode, feedback pins, V_LOCK
0x013	CONTROL_F	0x00	Watchdog reset, shutdown and wake-up
0x014	PD_DIS	0x40	Disable / pause blocks when below the PSS sequencer PD_DIS slot
0x015	GPIO_0_1	0x54	GPIO 0 and 1 control
0x016	GPIO_2_3	0x75	GPIO 2 and 3 control
0x017	GPIO_4_5	0x47	GPIO 4 and 5 control
0x018	GPIO_6_7	0x64	GPIO 6 and 7 control
0x019	GPIO_8_9	0x66	GPIO 8 and 9 control
0x01A	GPIO_10_11	0x67	GPIO 10 and 11 control
0x01B	GPIO_12_13	0x57	GPIO 12 and 13 control
0x01C	GPIO_14_15	0x66	GPIO 14 and 15 control registers
0x01D	GPIO_MODE0_7	0xFE	GPIO 0-7 mode control
0x01E	GPIO_MODE8_15	0xFF	GPIO 8-15 mode control
0x01F	SWITCH_CONT	0xB0	Rail switches

## Renesas R-Car E2 Platform for Automotive Infotainment

Register Address	Function	Register Value	Register Description
0x020	BCORE2_CONT	0x00	BUCK CORE2 Control
0x021	BCORE1_CONT	0x00	BUCK CORE1 Control
0x022	BPRO_CONT	0x00	BUCK PRO Control
0x023	BMEM_CONT	0x00	BUCK MEM Control
0x024	BIO_CONT	0x00	BUCK IO Control
0x025	BPERI_CONT	0x00	BUCK PERI Control
0x026	LDO1_CONT	0x00	LDO1 Control
0x027	LDO2_CONT	0x08	LDO2 Control
0x028	LDO3_CONT	0x20	LDO3 Control
0x029	LDO4_CONT	0x40	LDO4 Control
0x02A	LDO5_CONT	0x00	LDO5 Control
0x02B	LDO6_CONT	0x00	LDO6 Control
0x02C	LDO7_CONT	0x00	LDO7 Control
0x02D	LDO8_CONT	0x60	LDO8 Control
0x02E	LDO9_CONT	0x00	LDO9 Control
0x02F	LDO10_CONT	0x00	LDO10 Control
0x030	LDO11_CONT	0x00	LDO10 Control
0x031	SUPPLIES	0x00	Vibrator output level
0x032	DVC_1	0x00	Dynamic voltage control
0x033	DVC_2	0x00	Dynamic voltage control
0x034	ADC_MAN	0x04	ADC manual and automatic measurement control
0x035	ADC_CONT	0x00	ADC automatic measurement control
0x036	VSYS_MON	0x40	
0x083	ID_2_1	0x27	PSS sequence control
0x084	ID_4_3	0x66	PSS sequence control
0x085	ID_6_5	0x01	PSS sequence control
0x086	ID_8_7	0x71	PSS sequence control
0x087	ID_10_9	0x06	PSS sequence control
0x088	ID_12_11	0x5A	PSS sequence control
0x089	ID_14_13	0x76	PSS sequence control
0x08A	ID_16_15	0x87	PSS sequence control
0x08B	ID_18_17	0x28	PSS sequence control
0x08C	ID_20_19	0xB0	PSS sequence control
0x08D	ID_22_21	0x00	PSS sequence control
0x08E	ID_24_23	0x01	PSS sequence control
0x08F	ID_26_25	0x01	PSS sequence control
0x090	ID_28_27	0x0B	PSS sequence control
0x091	ID_30_29	0x00	PSS sequence control

## Renesas R-Car E2 Platform for Automotive Infotainment

Register Address	Function	Register Value	Register Description
0x092	ID_32_31	0xA0	PSS sequence control
0x095	SEQ_A	0xC5	PSS sequencer slot end points
0x096	SEQ_B	0x2E	PSS sequencer slot end points
0x097	WAIT	0x54	Power sequencer wait cycle
0x098	EN_32K	0xE8	RTC clocking control
0x099	RESET	0x41	Reset timer control
0x09A	BUCK_ILIM_A	0xFF	Buck current limit
0x09B	BUCK_ILIM_B	0xFF	Buck current limit
0x09C	BUCK_ILIM_C	0xFF	Buck current limit
0x09D	BCORE2_CFG	0x01	BUCKCORE2 control
0x09E	BCORE1_CFG	0x00	BUCKCORE1 control
0x09F	BPRO_CFG	0x19	BUCKPRO control
0x0A0	BIO_CFG	0x01	BUCKPRO control
0x0A1	BMEM_CFG	0x01	BUCKMEM control
0x0A2	BPERI_CFG	0x21	BUCKPERI control
0x0A3	VBCORE2_A	0x78	BUCKCORE2 voltage A
0x0A4	VBCORE1_A	0x49	BUCKCORE1 voltage A
0x0A5	VBPRO_A	0x16	BUCKPRO voltage A
0x0A6	VBMEM_A	0x7D	BUCKMEM voltage A
0x0A7	VBIO_A	0x7D	BUCKIO voltage A
0x0A8	VBPERI_A	0x32	BUCKPERI voltage A
0x0A9	VLDO1_A	0xAD	LDO* voltage A
0x0AA	VLDO2_A	0x3C	LDO* voltage A
0x0AB	VLDO3_A	0x78	LDO* voltage A
0x0AC	VLDO4_A	0x78	LDO* voltage A
0x0AD	VLDO5_A	0x32	LDO* voltage A
0x0AE	VLDO6_A	0xB2	LDO* voltage A
0x0AF	VLDO7_A	0x14	LDO* voltage A
0x0B0	VLDO8_A	0x32	LDO* voltage A
0x0B1	VLDO9_A	0xB2	LDO* voltage A
0x0B2	VLDO10_A	0xB2	LDO* voltage A
0x0B3	VLDO11_A	0x94	LDO* voltage A
0x0B4	VBCORE2_B	0x78	BUCKCORE2 voltage B
0x0B5	VBCORE1_B	0x46	BUCKCORE1 voltage B
0x0B6	VBPRO_B	0x16	BUCKPRO voltage B
0x0B7	VBMEM_B	0x7D	BUCKMEM voltage B
0x0B8	VBIO_B	0x7D	BUCKIO voltage B
0x0B9	VBPERI_B	0x32	BUCKPERI voltage B

## Renesas R-Car E2 Platform for Automotive Infotainment

Register Address	Function	Register Value	Register Description
0x0BA	VLDO1_B	0x9E	LDO* voltage B
0x0BB	VLDO2_B	0x3C	LDO* voltage B
0x0BC	VLDO3_B	0x2D	LDO* voltage B
0x0BD	VLDO4_B	0x2D	LDO* voltage B
0x0BE	VLDO5_B	0xB2	LDO* voltage B
0x0BF	VLDO6_B	0xB2	LDO* voltage B
0x0C0	VLDO7_B	0x94	LDO* voltage B
0x0C1	VLDO8_B	0x14	LDO* voltage B
0x0C2	VLDO9_B	0xB2	LDO* voltage B
0x0C3	VLDO10_B	0xB2	LDO* voltage B
0x0C4	VLDO11_B	0x94	LDO* voltage B
0x0C5	BBAT_CONT	0x00	Backup battery charger
0x0C6	GPO11_LED	0x00	High power GPO PWM
0x0C7	GPO14_LED	0x00	High power GPO PWM
0x0C8	GPO15_LED	0x00	High power GPO PWM
0x0C9	ADC_CFG	0xE0	ADC automatic measurement control
0x0CA	AUTO1_HIGH	0x00	ADC measurement thresholds
0x0CB	AUTO1_LOW	0x00	ADC measurement thresholds
0x0CC	AUTO2_HIGH	0x00	ADC measurement thresholds
0x0CD	AUTO2_LOW	0x00	ADC measurement thresholds
0x0CE	AUTO3_HIGH	0x00	ADC measurement thresholds
0x0CF	AUTO3_LOW	0x00	ADC measurement thresholds
0x105	INTERFACE	0xB9	Host interfaces
0x106	CONFIG_A	0xA6	Host interfaces and other IOs
0x107	CONFIG_B	0x16	VDD_FAULT comparator
0x108	CONFIG_C	0x50	Buck duty cycle and clock polarity
0x109	CONFIG_D	0x00	
0x10A	CONFIG_E	0xBF	BUCK and rail switch default settings
0x10B	CONFIG_F	0x00	LDO default and bypass mode settings
0x10C	CONFIG_G	0xDE	LDO default settings
0x10D	CONFIG_H	0xF0	
0x10E	CONFIG_I	0x04	
0x10F	CONFIG_J	0xC0	
0x110	CONFIG_K	0x00	GPIO pull resistors
0x111	CONFIG_L	0x20	GPIO pull resistors
0x112	CONFIG_M	0x00	
0x113	CONFIG_N	0x00	
0x114	MON_REG_1	0xCE	

## Renesas R-Car E2 Platform for Automotive Infotainment

Register Address	Function	Register Value	Register Description
0x115	MON_REG_2	0x00	
0x116	MON_REG_3	0x00	
0x117	MON_REG_4	0xEC	
0x121	GP_ID_0	0x01	
0x122	GP_ID_1	0x00	
0x123	GP_ID_2	0x00	
0x124	GP_ID_3	0x00	
0x125	GP_ID_4	0x00	
0x126	GP_ID_5	0x00	
0x127	GP_ID_6	0x00	
0x128	GP_ID_7	0x00	
0x129	GP_ID_8	0x00	
0x12A	GP_ID_9	0x00	
0x12B	GP_ID_10	0x00	
0x12C	GP_ID_11	0x00	
0x12D	GP_ID_12	0x00	
0x12E	GP_ID_13	0x00	
0x12F	GP_ID_14	0x00	
0x130	GP_ID_15	0x00	
0x131	GP_ID_16	0x00	
0x132	GP_ID_17	0x00	
0x133	GP_ID_18	0x00	
0x134	GP_ID_19	0x00	
0x183	CUSTOMER_ID	0x00	Chip ID
0x184	CONFIG_ID	0x65	Customer ID

---

**Renesas R-Car E2 Platform for Automotive  
Infotainment****Revision History**

Revision	Date	Description
1.0	02-Apr-2015	Initial version.
2.0	14-Oct-2015	Update to corporate template
3.0	18-Feb-2022	File was rebranded with new logo, copyright and disclaimer

## Renesas R-Car E2 Platform for Automotive Infotainment

### Status Definitions

Status	Definition
DRAFT	The content of this document is under review and subject to formal approval, which may result in modifications or additions.
APPROVED or unmarked	The content of this document has been approved for publication.

### RoHS Compliance

Dialog Semiconductor's suppliers certify that its products are in compliance with the requirements of Directive 2011/65/EU of the European Parliament on the restriction of the use of certain hazardous substances in electrical and electronic equipment. RoHS certificates from our suppliers are available on request.

## IMPORTANT NOTICE AND DISCLAIMER

RENESAS ELECTRONICS CORPORATION AND ITS SUBSIDIARIES (“RENESAS”) PROVIDES TECHNICAL SPECIFICATIONS AND RELIABILITY DATA (INCLUDING DATASHEETS), DESIGN RESOURCES (INCLUDING REFERENCE DESIGNS), APPLICATION OR OTHER DESIGN ADVICE, WEB TOOLS, SAFETY INFORMATION, AND OTHER RESOURCES “AS IS” AND WITH ALL FAULTS, AND DISCLAIMS ALL WARRANTIES, EXPRESS OR IMPLIED, INCLUDING, WITHOUT LIMITATION, ANY IMPLIED WARRANTIES OF MERCHANTABILITY, FITNESS FOR A PARTICULAR PURPOSE, OR NON-INFRINGEMENT OF THIRD-PARTY INTELLECTUAL PROPERTY RIGHTS.

These resources are intended for developers who are designing with Renesas products. You are solely responsible for (1) selecting the appropriate products for your application, (2) designing, validating, and testing your application, and (3) ensuring your application meets applicable standards, and any other safety, security, or other requirements. These resources are subject to change without notice. Renesas grants you permission to use these resources only to develop an application that uses Renesas products. Other reproduction or use of these resources is strictly prohibited. No license is granted to any other Renesas intellectual property or to any third-party intellectual property. Renesas disclaims responsibility for, and you will fully indemnify Renesas and its representatives against, any claims, damages, costs, losses, or liabilities arising from your use of these resources. Renesas' products are provided only subject to Renesas' Terms and Conditions of Sale or other applicable terms agreed to in writing. No use of any Renesas resources expands or otherwise alters any applicable warranties or warranty disclaimers for these products.

(Disclaimer Rev.1.01)

### Corporate Headquarters

TOYOSU FORESIA, 3-2-24 Toyosu,  
Koto-ku, Tokyo 135-0061, Japan  
[www.renesas.com](http://www.renesas.com)

### Trademarks

Renesas and the Renesas logo are trademarks of Renesas Electronics Corporation. All trademarks and registered trademarks are the property of their respective owners.

### Contact Information

For further information on a product, technology, the most up-to-date version of a document, or your nearest sales office, please visit [www.renesas.com/contact-us/](http://www.renesas.com/contact-us/).