

RL78/G23

Pedometer with Accelerometer Sample sketch (Arduino™ sketch)

Introduction

This application note explains how to use the RL78/G23-64p Fast Prototyping Board (FPB) library for Arduino to control an accelerometer to count steps.

Target Device

Evaluation Board : RL78/G23-64p Fast Prototyping Board

Accelerometer : GY 291 ADXL345

LCD Module : EMB-LCD-1602B

Mobile Battery : CHE-061-WH-IOT2

Trademarks

Arduino is a trademark of Arduino SA.

Contents

1. System overview	3
1.1 Modules to be used	4
1.1.1 Accelerometer	5
1.1.2 LCD module.....	5
1.2 Operations	6
2. Operation confirmation environment	7
3. Build development environment.....	8
3.1 Board connection.....	8
3.2 List of pins used.....	9
3.3 Setup of Arduino™ IDE	10
4. Software	13
4.1 Overview of sample code	13
4.1.1 Algorithm of counting steps	14
4.2 Sketch example used in sample code.....	16
4.2.1 Adafruit ADXL345 / sensortest	16
4.2.2 LiquidCrystal > HelloWorld	18
4.3 API functions	19
4.4 Operating procedure of sample sketch	20
4.5 Flowchart	24
4.5.1 main processing	24
4.5.2 Sub routine	26
4.5.3 Specification of functions.....	27
5. Notes	28
5.1 COM port is not displayed on the Windows Device Manager	28
5.2 Program is not written correctly to RL78/G23-64p Fast Prototyping Board	29
5.3 After the power supply by the mobile battery is started, it immediately stops	29
6. Sample Code.....	30
7. Reference Documents	30
Revision History	31

1. System overview

This system is composed of the RL78/G23-64p Fast Prototyping Board (RL78/G23-64p FPB), an accelerometer and an LCD module. Arduino™ IDE is used for creating a program and writing a program to RL78/G23.

Also, with this system, after the power of the FPB is turned on, the FPB starts counting steps and displays the current number of steps on the LCD module. While counting steps, LED1 lights up; when the user switch is pressed, the FPB finishes counting and LED2 lights up. After the user switch is pressed, the FPB moves to HALT mode.

The block configuration of the sample code used in this system is shown below.

Figure 1-1 Block configuration of software

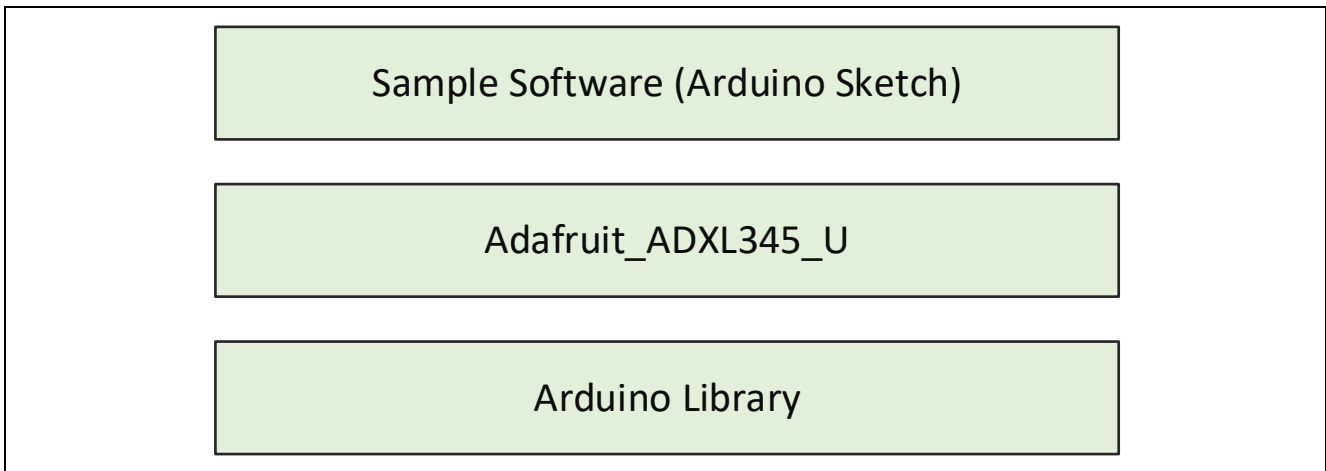

1.1 Modules to be used

The simple diagram of this system configuration is shown below.

Figure 1-2 System configuration during development

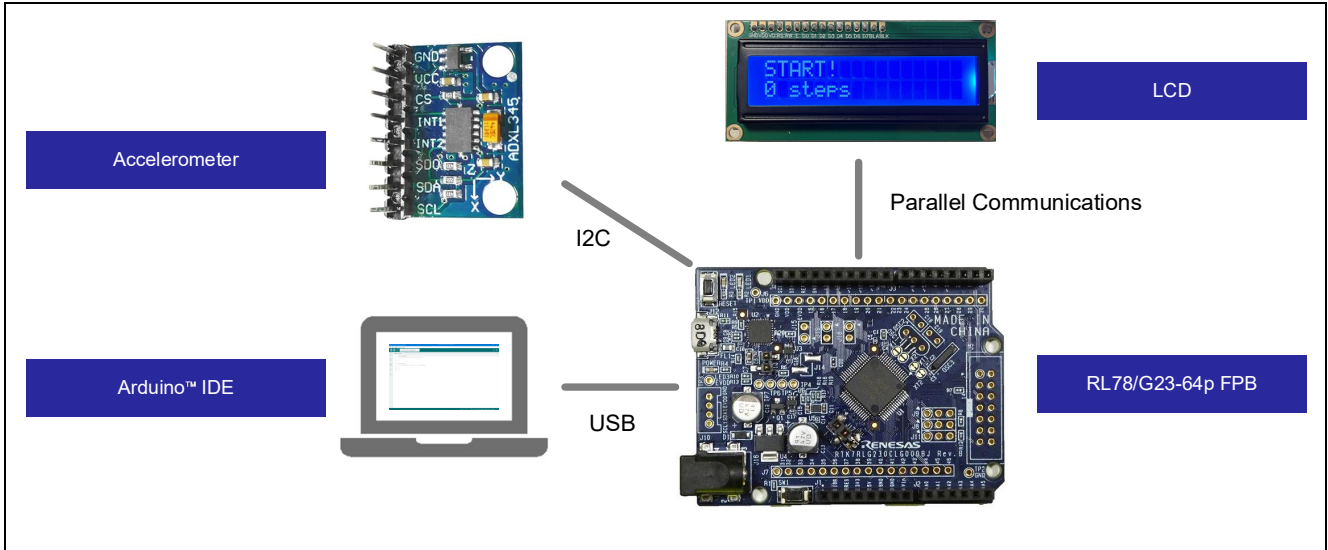
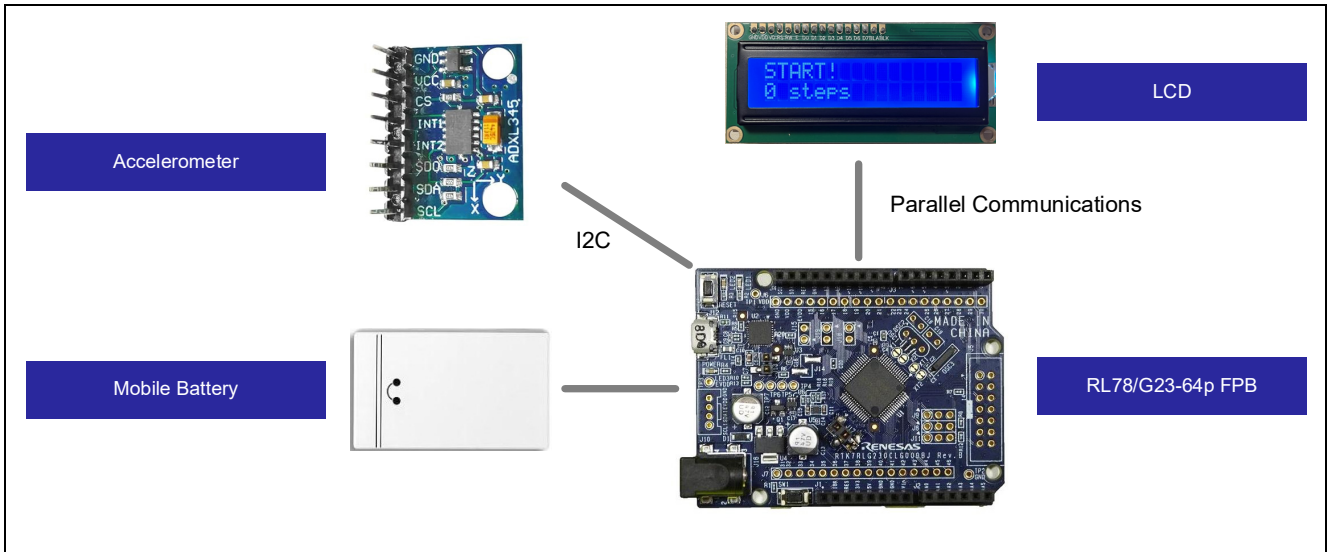

Figure 1-3 System configuration during step measurement



1.1.1 Accelerometer

An accelerometer is a sensor that detects the acceleration of an object and is used to measure tilt, vibration and impact. In this sample system, a three-axis accelerometer is used, and it measures the acceleration in the direction of the X-axis, Y-axis and Z-axis in real time. This allows for capturing the motion of an object in three dimensions. The communication interface is I2C, the FPB gets acceleration data from the sensor, and it measures steps based on the algorithm described later.

The accelerometer used in this system and the measurement directions for each axis are shown in Figure 1-4.

Figure 1-4 The accelerometer and the measurement directions for each axis

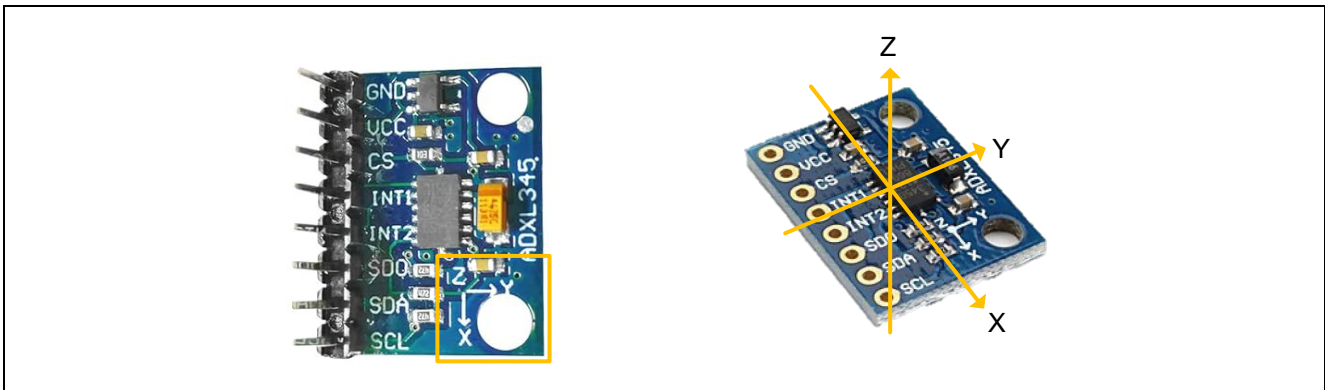

1.1.2 LCD module

It is a display for showing characters, numbers, and symbols. In this system, an LCD module equipped with 1602A compatible with LCD driver HD44780 is used, and it allows for 16 characters x 2 lines display. This LCD module supports the parallel communication interface, using the Arduino LiquidCrystal library, control is performed via parallel communication.

The LCD module used in this system is shown in Figure 1-5.

Figure 1-5 LCD module



1.2 Operations

The overview of the operations is shown in Figure 1-6.

- (1) After the power of the FPB is turned on, the FPB turns off LED1 and LED2, and checks if the accelerometer is connected.
- (2) If the accelerometer is not connected, the LCD module will display 'No sensor'. It returns to (1) when the FPB is restarted or when the reset switch is pressed.
- (3) If the connection of the accelerometer has been confirmed, the FPB will obtain the configuration information of the connected accelerometer.
- (4) After obtaining the information from the accelerometer, LED1 lights up, and the FPB starts measuring steps.
- (5) After calculating the number of steps from the changes in acceleration, the FPB displays the number of steps on the LCD module.
- (6) If the user switch is pressed, the FPB finishes measuring steps. After that, LED1 turns off and LED2 lights up. After the user switch is pressed, the FPB moves to HALT mode.

Remark. (3) can be confirmed on serial monitor of Arduino™ IDE during development.

Figure 1-6 The overview of the operations

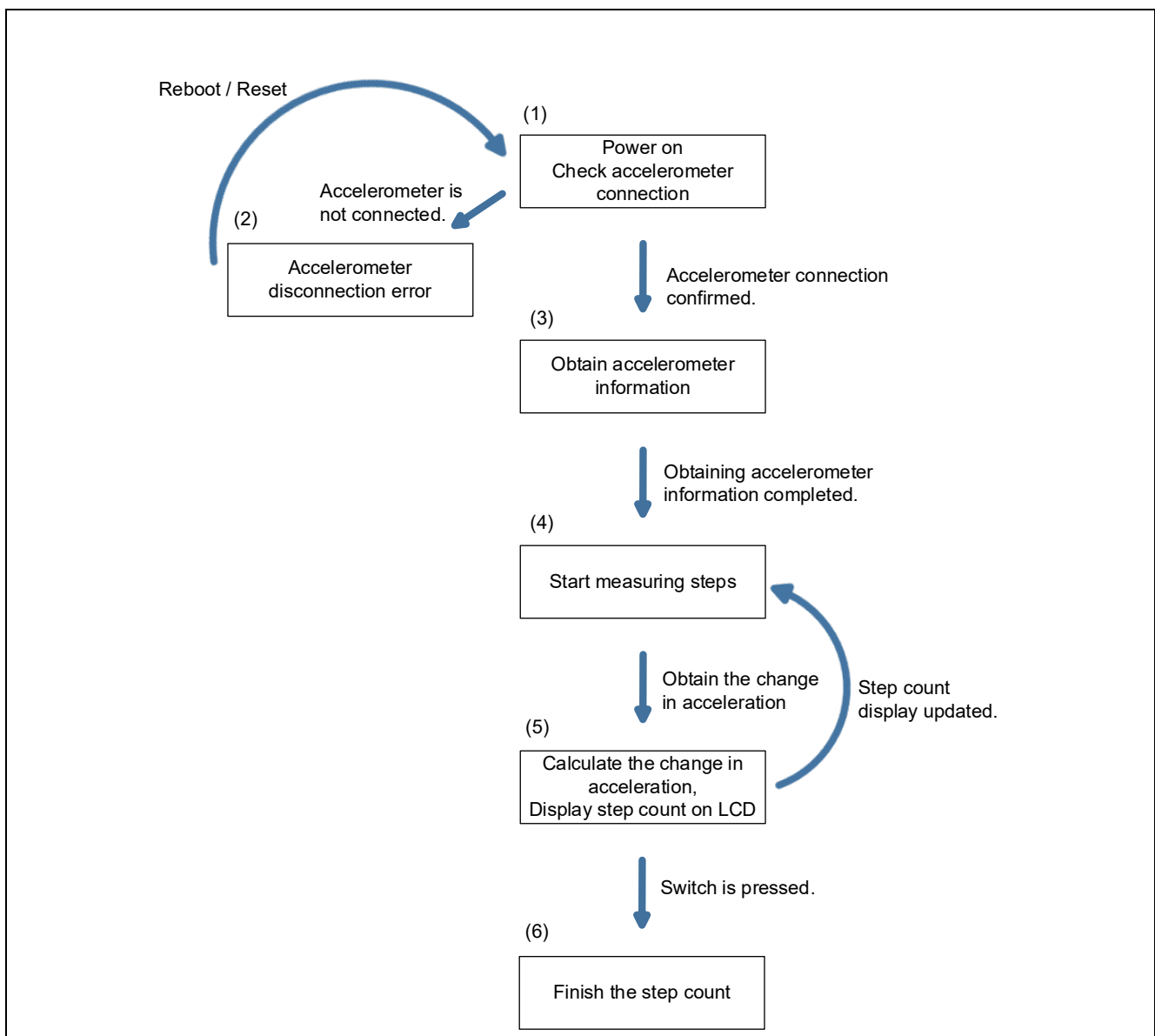

2. Operation confirmation environment

The operation of the sample code provided by this application note has been tested under the following conditions.

Table 2-1 Operation confirmation environments (Hardware)

Item	Description
Evaluation board	RL78/G23-64p Fast Prototyping Board – RTK7RLG230CLG000BJ
Accelerometer	GY 291 ADXL345
LCD module	EMB-LCD-1602B
Mobile battery	CHE-061-WH-IOT2 ^{Note1}
Operating voltage	5V

(Note1) The mobile battery with an auto power off function will cut off the power supply if it's used with a low power consumption system for a certain period. Therefore, please use the mobile battery with the auto power off function disabled.

Table 2-2 Operation confirmation environments (Software)

Item	Description	Version
OS	Windows 10	-
Integrated development environment (IDE)	Arduino™ IDE	2.3.2
Library	RL78/G23-64p FPB library for Arduino	2.3.1

3. Build development environment

How to connect boards and how to set up the Arduino™ IDE are explained.

The Arduino™ IDE 2.3.2 is used in this system. Installation of the Arduino™ IDE 2.3.2 or later is necessary if it is not installed.

<https://www.arduino.cc/en/software>

3.1 Board connection

The connection of the RL78/G23-64p FPB, the accelerometer and the LCD module is shown in Figure 3-1.

USB is used for power supply to the RL78/G23-64p FPB in this system. For the power supply, check the circuit of the RL78/G23-64p FPB by referring to the manual, and set jumpers if required.

In this system, jumpers of the RL78/G23-64p FPB are set as shown in Table 3-1.

Table 3-1 Jumper pins setting of RL78/G23-64p FPB

Jumper pin	Setting	Function
J8	1-2 short-circuit	COM port debugging
J9		
J11		
J13	Open-circuit	
J17	1-2 short-circuit	5V power supply to MCU

Figure 3-1 Connection of boards

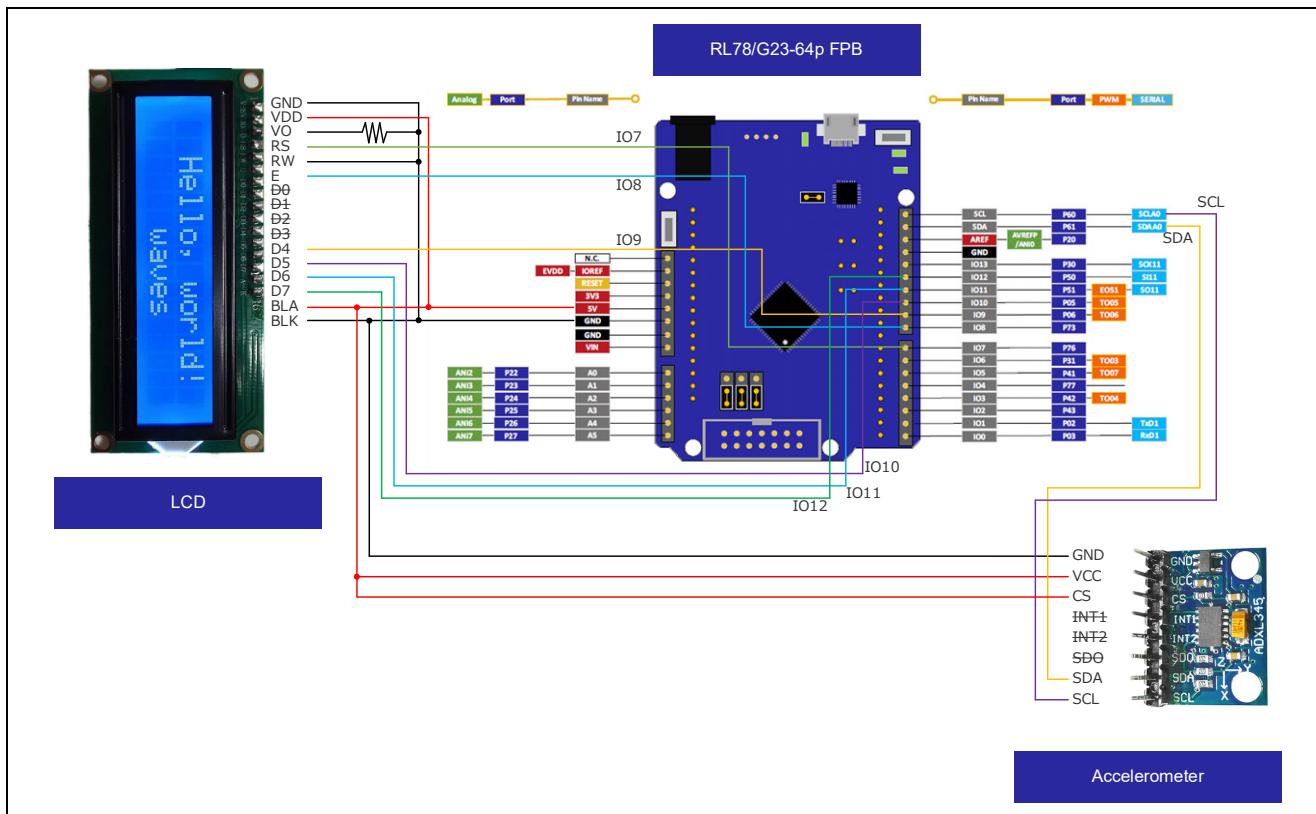

3.2 List of pins used

The pins used in this system are shown below.

Table 3-2 Pins used

Item	Arduino™ signal name	Pin number of MCU	Pin
I ² C	SDA	18	P61
	SCL	17	P60
LCD control	IO7	23	P76
	IO8	26	P73
	IO9	30	P06
	IO10	31	P05
	IO11	34	P51
	IO12	33	P50
V _{DD}	5V	-	-
GND	GND	-	-

For detailed pin descriptions of each board, refer to the following manuals.

RL78/G23-64p Fast Prototyping Board User's Manual (R20UT4814)

3.3 Setup of Arduino™ IDE

The setup procedure of Arduino™ IDE is explained.

Remark. The setup procedure is almost the same as the procedure explained on the [Quick Start Guide : renesas/Arduino Wiki · GitHub](#). The sample sketch to flash LED is described on the above site. Refer to it if required.

1. Start the Arduino™ IDE.
2. Click the [Tools] - [Board] - [Boards Manager...] menu.

Figure 3-2 Selection of [Boards Manager...]

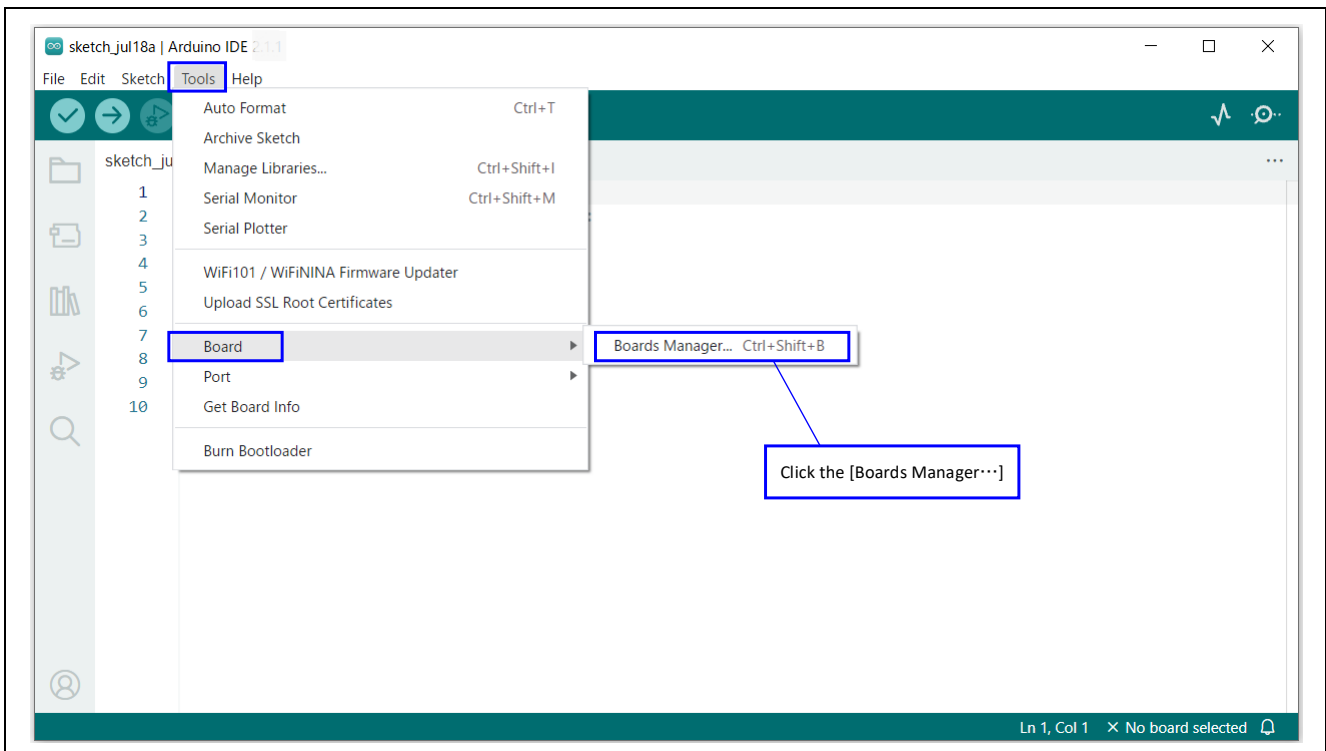

3. Select “All” at the [Type] and input “RL78/G23” in the textbox. Then, “RL78/G23-64p Fast Prototyping Board” is displayed. Next, click the [INSTALL].

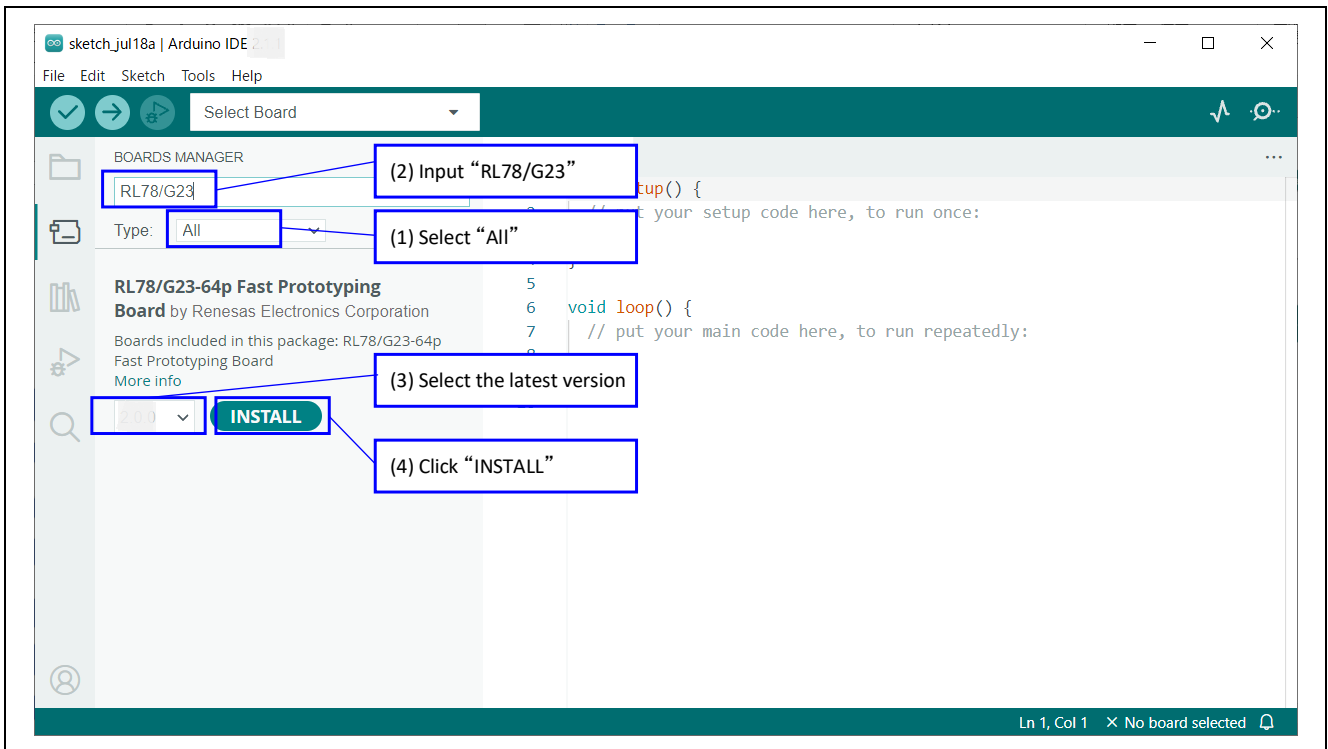
Figure 3-3 Installation of Board Manager

4. Select the serial port assigned to the RL78/G23-64p FPB from the [Tools] - [Port] menu. COM port number can be checked at the Device Manager of Windows.

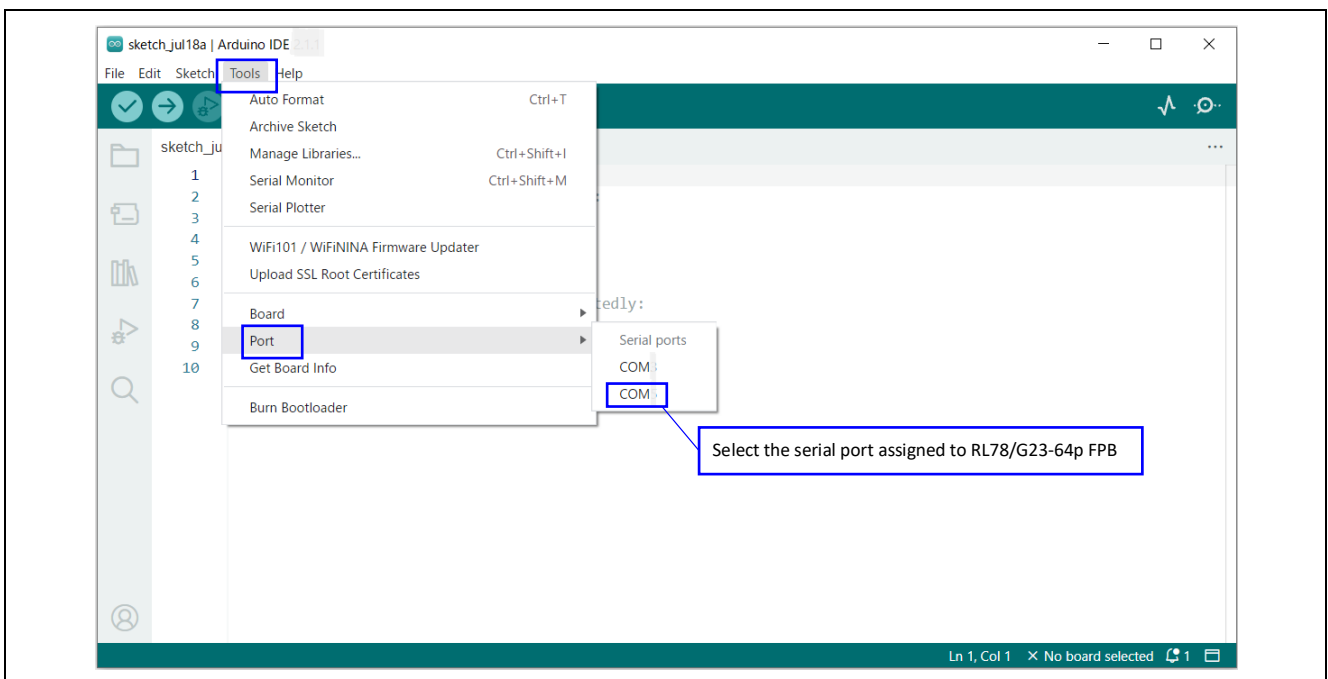
Figure 3-4 Selection of serial port

- 5. Select the [Tools] - [Board] - [RL78/G23-64p Fast Prototyping Board] - [RL78/G23-64p Fast Prototyping Board] menu.

Figure 3-5 Selection of board

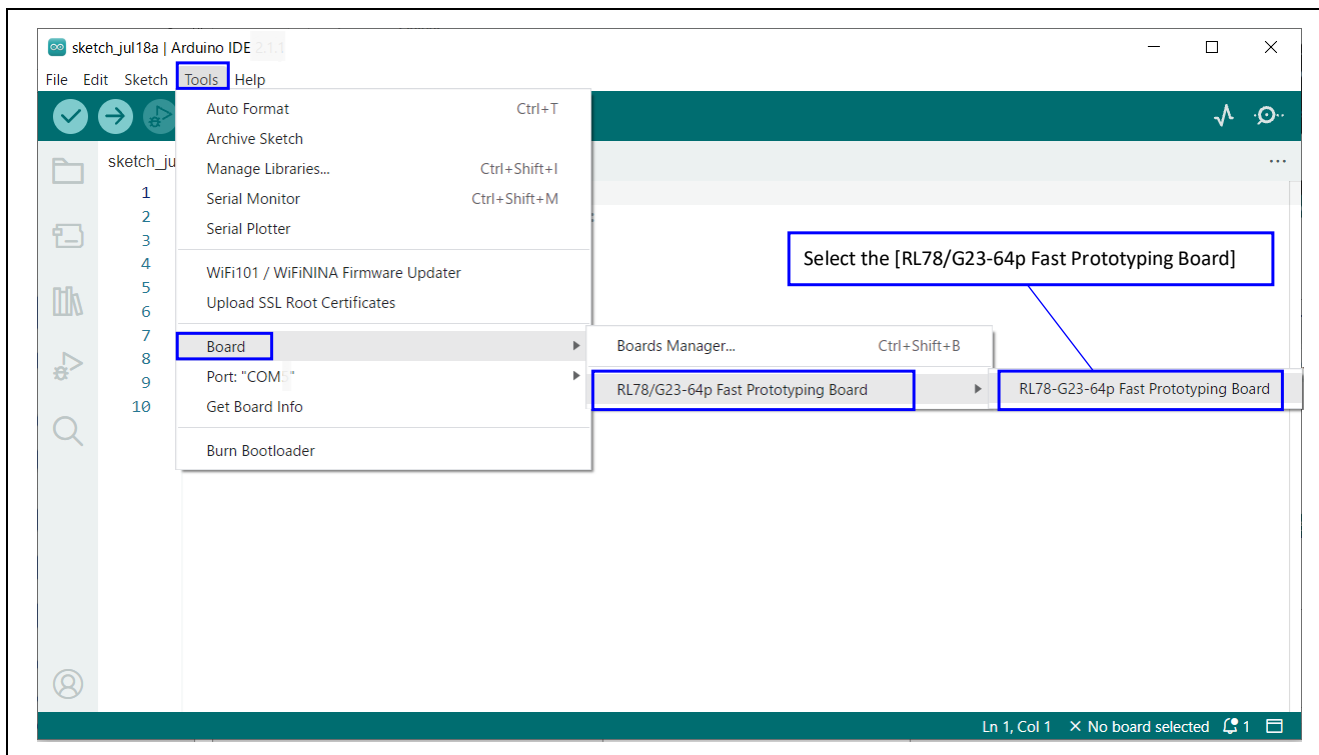

4. Software

4.1 Overview of sample code

This sample code is a sample sketch executed on the Arduino™ IDE composed by the libraries listed in Table 4-1.

Table 4-1 Overview of sample code for used libraries

Used libraries	Overview
Adafruit_ADXL345	It communicates with the accelerometer using I ² C and to obtain acceleration data.
LiquidCrystal	It controls the LCD module and displays characters.

The file structure is shown below.

For details of API functions, refer to “4.3 API functions”, for details of the sample sketch, “4.4 Operating procedure of sample sketch”.

Figure 4-1 File structure of sample code

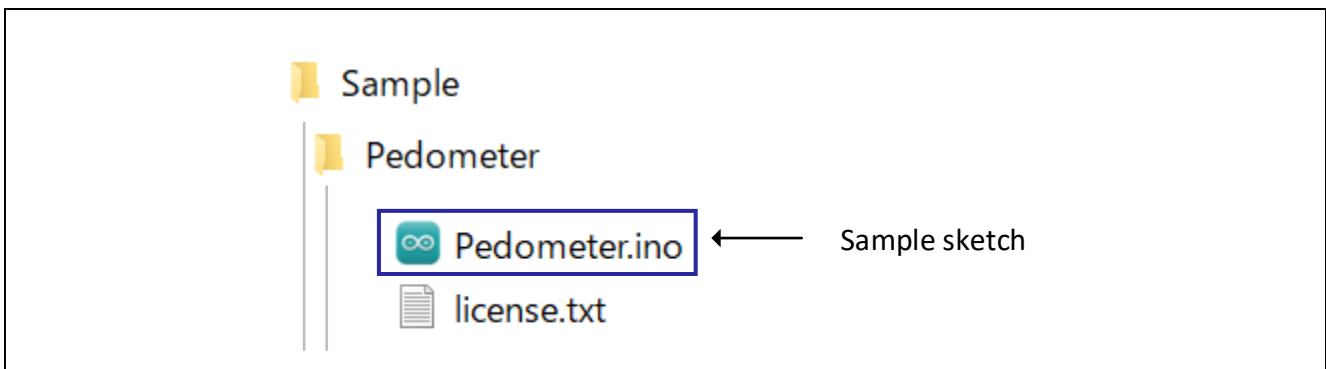

The content displayed on the serial monitor during development is shown in Figure 4-2.

Figure 4-2 Content displayed on the serial monitor during development

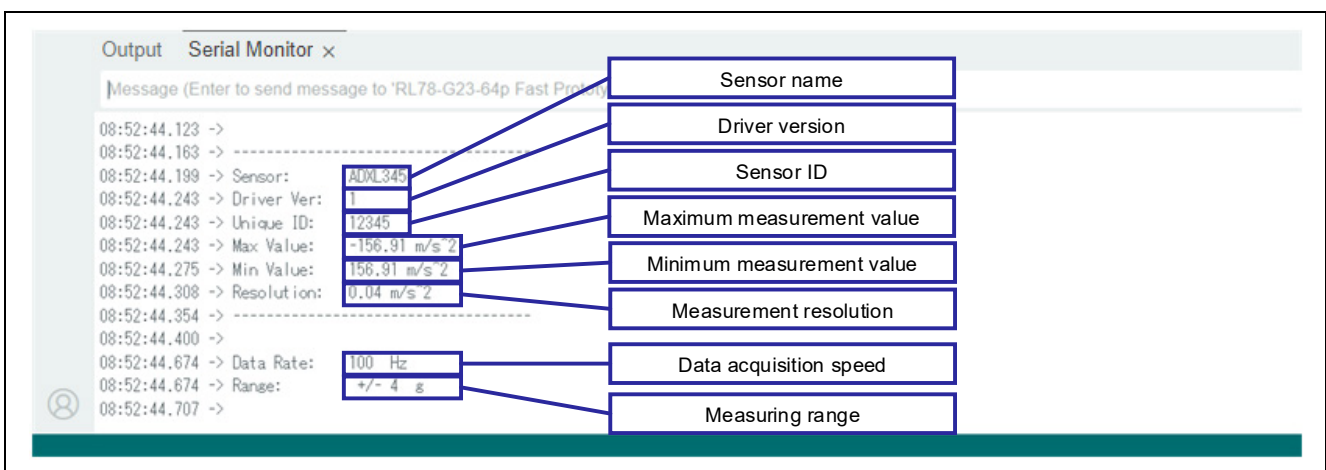

4.1.1 Algorithm of counting steps

During walking, the body moves in a specific rhythm forward and backward, right to left, and up and down. As a result, the acceleration changes periodically.

The acceleration along the three axes: X, Y and Z during walking is shown in Figure 4-3.

Figure 4-3 Changes of the acceleration along the three axes during walking

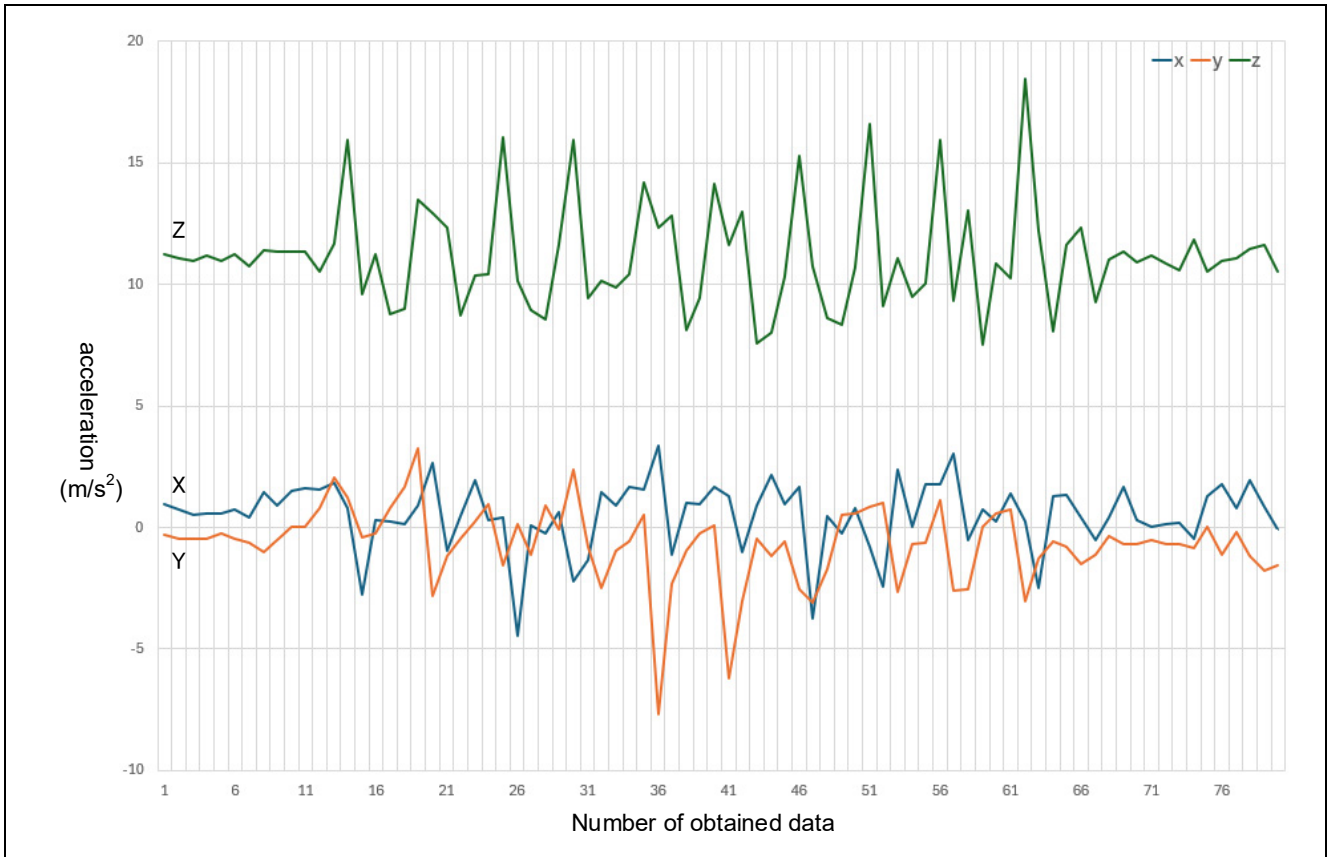

It is necessary to integrate the acceleration data from three axes to grasp the walking movement. To achieve this, calculate the magnitude of a three-dimensional vector by squaring each of the acceleration values from the three axes, summing them, and taking the square root. The three-dimensional vector formula is as follows.

the magnitude of a three – dimensional vector

$$= \sqrt{(\text{acceleration of X axis})^2 + (\text{acceleration of Y axis})^2 + (\text{acceleration of Z axis})^2}$$

Using this three-dimensional vector makes counting steps possible by capturing the change in acceleration associated with periodic movement during walking. The sample program detects the maximum and minimum based on the noise-reduced data obtained by applying a moving average to three sets of three-dimensional vector data. When the difference between the maximum and minimum exceed the threshold, the FPB counts steps.

The counting steps are visually shown in Figure 4-4.

Figure 4-4 The counting steps

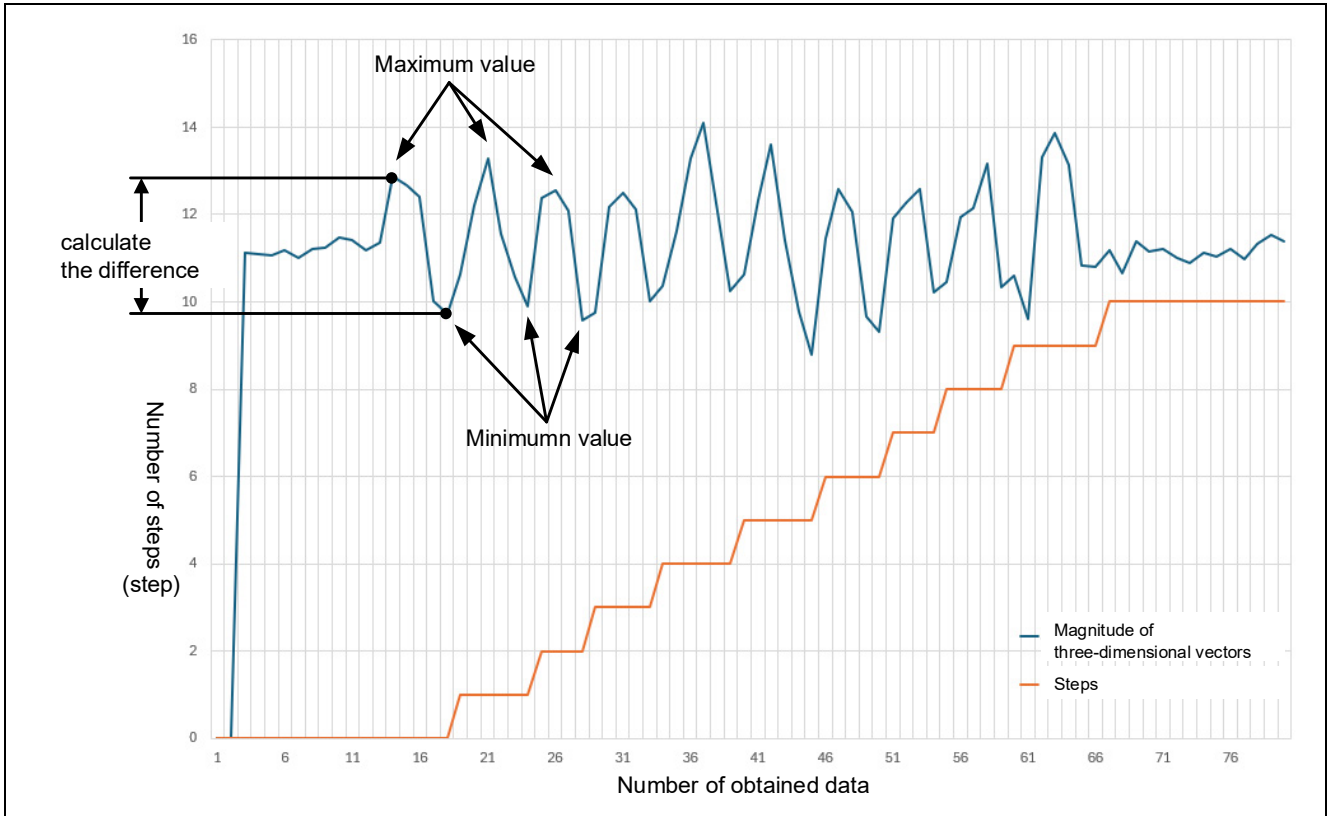

3. Click the [Files] – [Examples] – [Adafruit ADXL345] – [sensortest] menu.

Figure 4-6 Selection of [Adafruit ADXL345] – [sensortest]

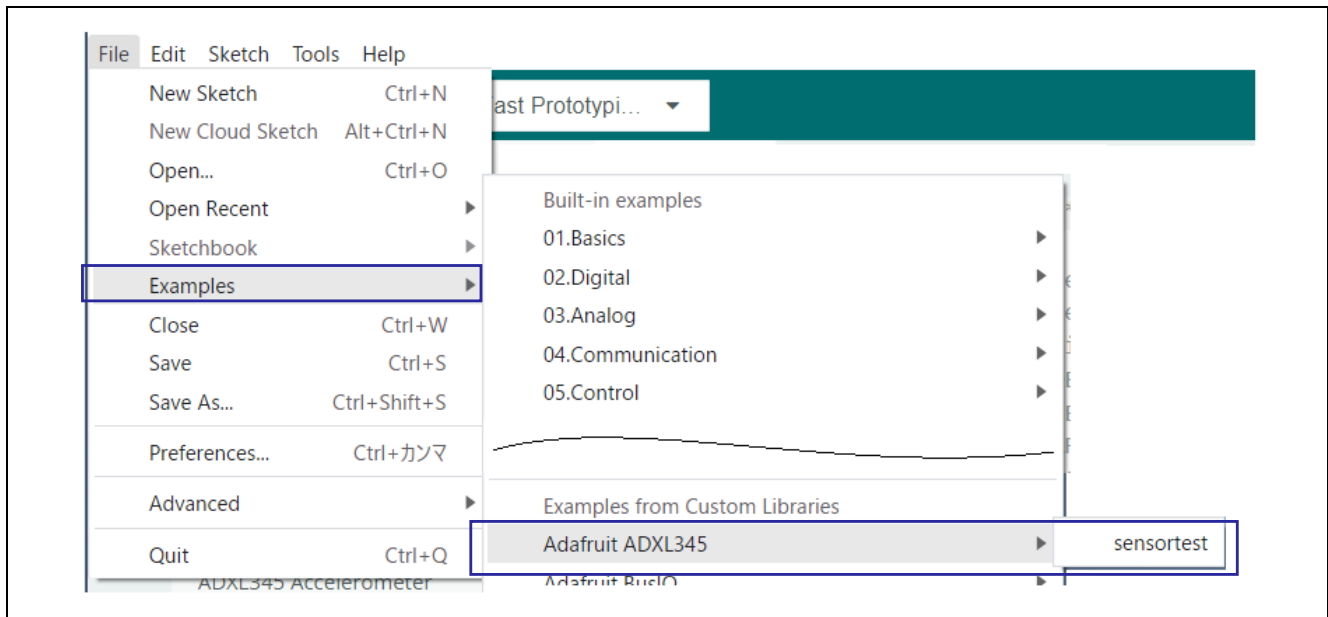

4.2.2 LiquidCrystal > HelloWorld

This is a sketch example that uses LiquidCrystal to display characters with the LCD module using parallel communication.

How to refer to the sketch example is as follows.

1. Start the Arduino™ IDE.
2. Click the [Files] - [Examples] - [LiquidCrystal] – [HelloWorld] menu.

Figure 4-7 Selection of [LiquidCrystal] – [HelloWorld]

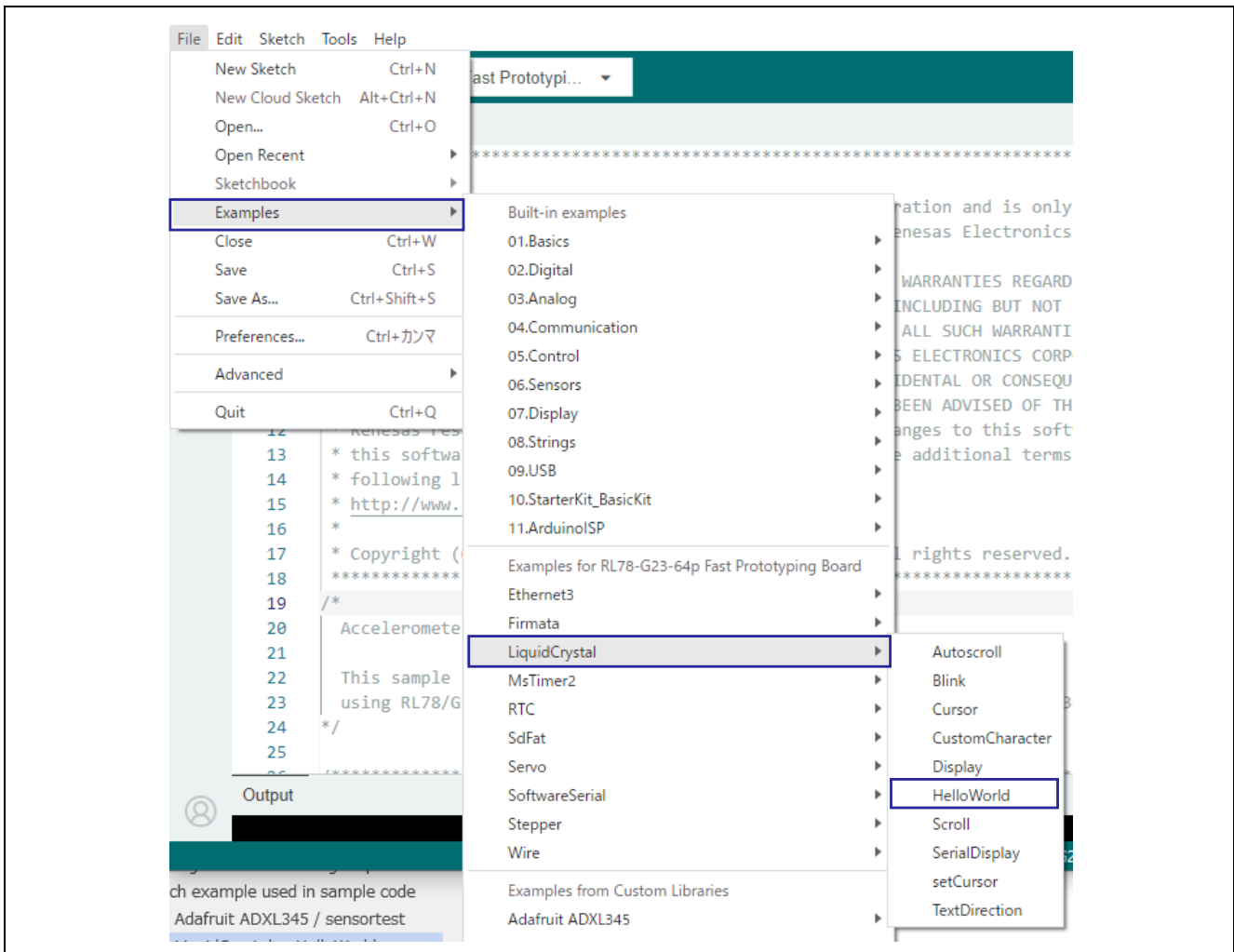

4.3 API functions

The API functions of each library are shown below.

Table 4-2 List of APIs

API function	Function
<code>digitalWrite(pin,value)</code>	Output HIGH/LOW from the digital pin.
<code>attachInterrupt(digitalPinToInterrupt(pin), ISR, mode)</code>	Specify a function to be executed when the external interrupt generated.
<code>accel.begin()</code>	Initialize I ² C communication with the accelerometer.
<code>accel.setRange(range)</code>	Define the measurement range(range) of the accelerometer.
<code>displaySensorDetails()</code>	Display the basic information of the accelerometer on the serial monitor.
<code>displayDataRate()</code>	Display data acquisition speed of the accelerometer on the serial monitor.
<code>displayRange()</code>	Display the measurement range of the accelerometer.
<code>accel.getEvent(&event)</code>	Acquire the acceleration data of X, Y, Z-axis stored in a structure(event).
<code>lcd.begin(cols, rows)</code>	Initialize the LCD module and specify the number of columns(cols) and rows(rows) of the display.
<code>lcd.setCursor(cols, rows)</code>	Place the LCD cursor on any columns(cols) and rows(rows).
<code>lcd.print()</code>	Output the texts on the LCD module.
<code>delay(ms)</code>	Stop the program for a specified number of seconds(ms).
<code>setPowerManagementMode(mode)</code>	Specify the power-saving mode(mode).

For API function specifications of each library, refer to the website of Arduino™ and the other.

[API List RL78G23 64pin · renesas/Arduino Wiki · GitHub](#)

[digitalWrite\(\) - Arduino Reference](#)

[attachInterrupt\(\) - Arduino Reference](#)

[GitHub - adafruit/Adafruit_ADXL345: Unified driver for the ADXL345 Accelerometer](#)

[LiquidCrystal - Arduino Reference](#)

[delay\(\) - Arduino Reference](#)

4.4 Operating procedure of sample sketch

The operation procedure of this sample sketch is shown below. Before the steps below, setup the Arduino™ IDE in the “3.3 Setup of Arduino™ IDE”.

1. Select the [File] - [Open...] menu to open the sample sketch “Pedometer.ino”.

Figure 4-8 Select sample sketch

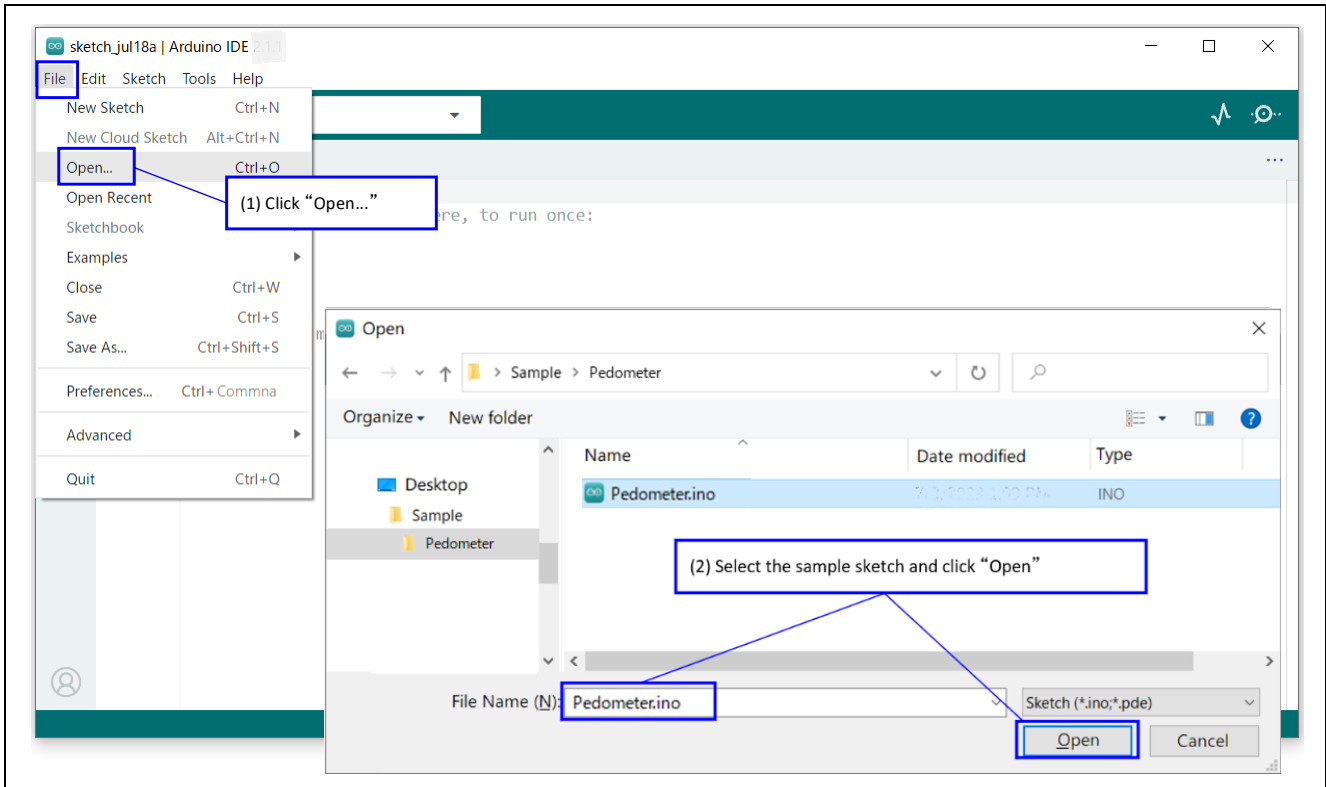

- Click the [Verify] icon to start compiling the sketch.

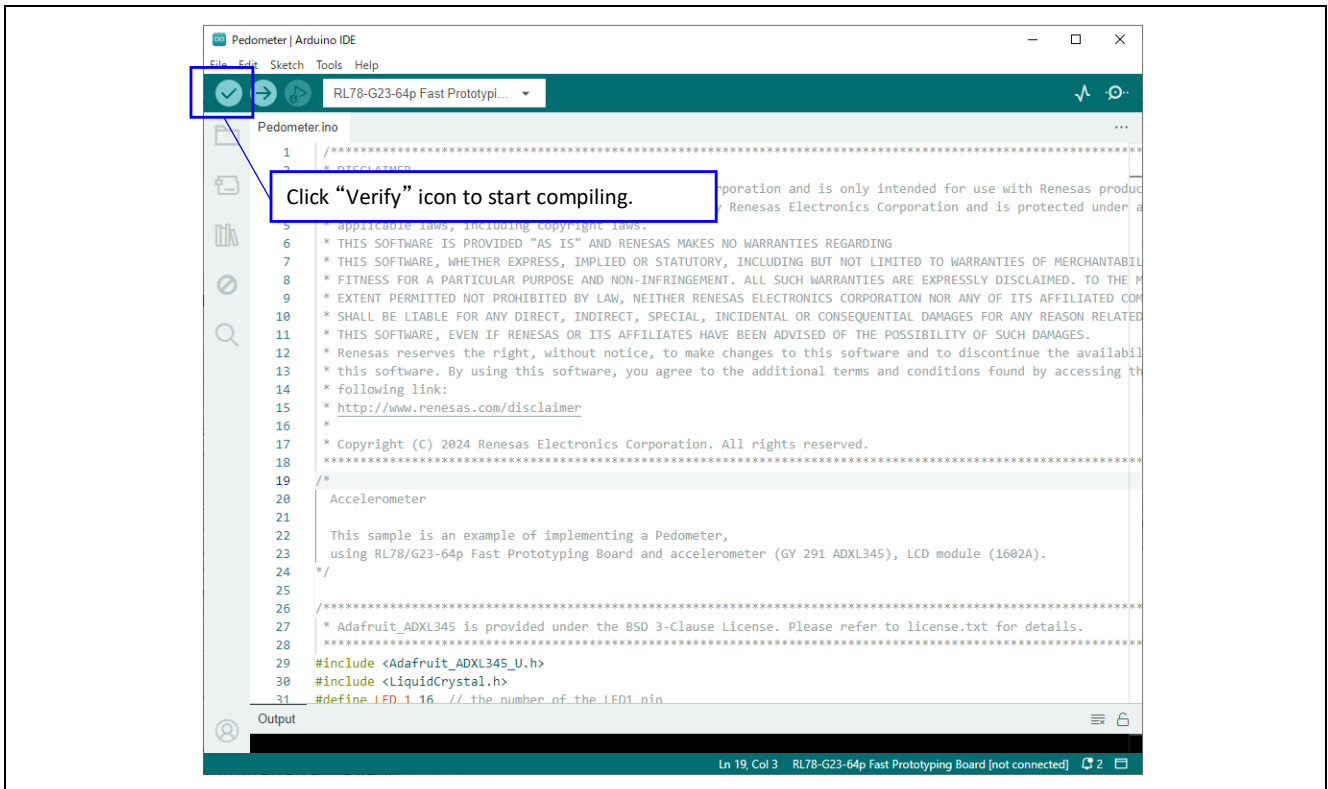
Figure 4-9 Compile sketch

- After compiling is finished, click the [Upload] icon to write the program to the device.

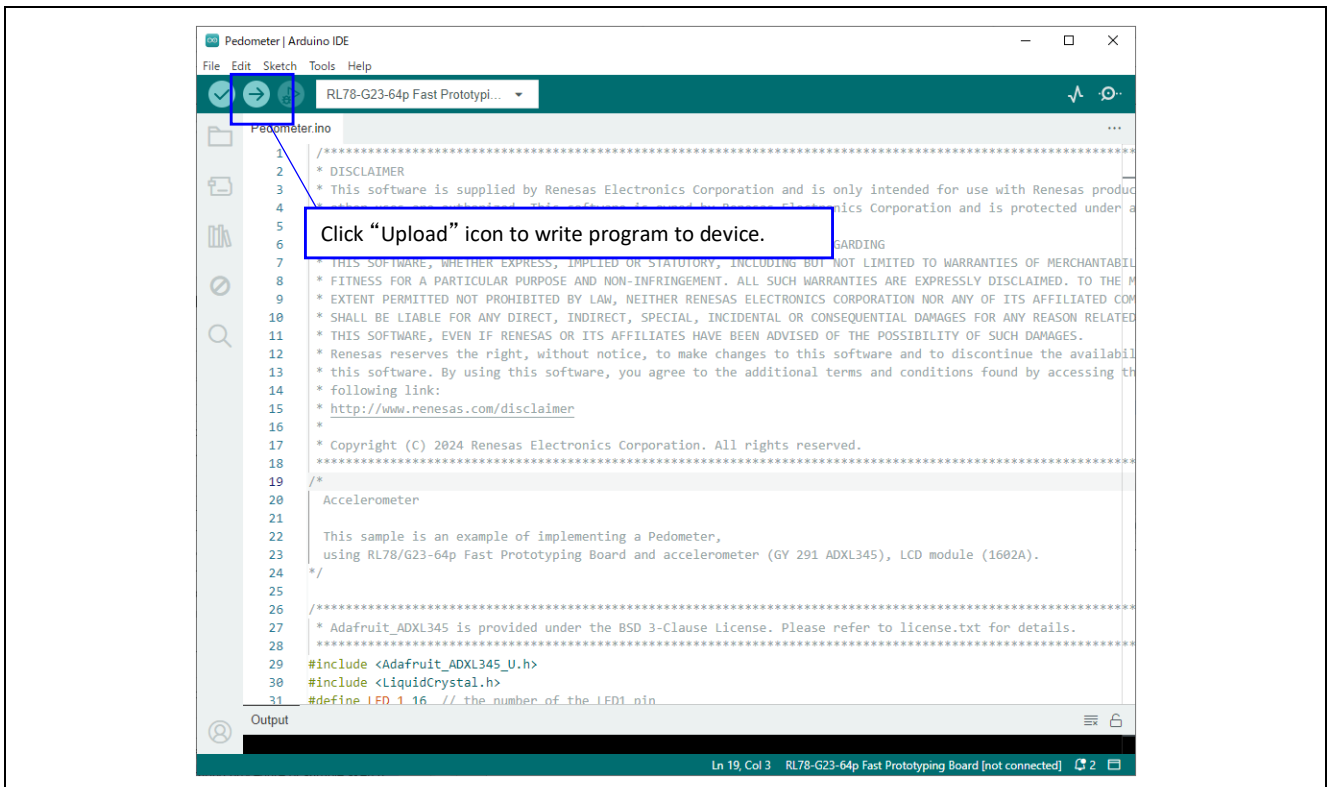
Figure 4-10 Write sketch to board

4. After writing is finished, RL78/G23 starts operation and checks the connection with the accelerometer. If the accelerometer is not connected, the text 'No sensor' is displayed on the LCD module.

Figure 4-11 Display of the LCD module when the accelerometer is not connected

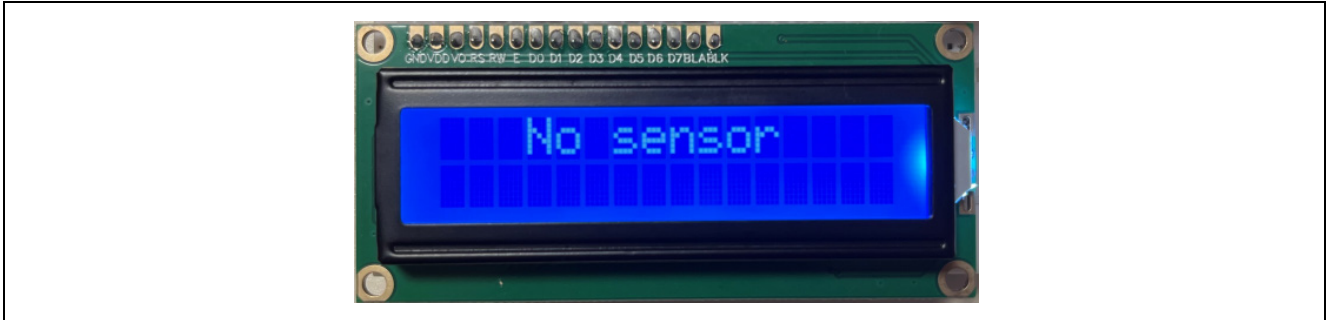

5. If the connection with the accelerometer confirmed, the LED1 lights up, and the text 'START!' is displayed on the LCD module, and the FPB starts counting steps. The display on the LCD module is updated every time steps are measured, so you can check steps in real time.

Figure 4-12 Position of the LED1 and the display of the LCD module when measuring steps

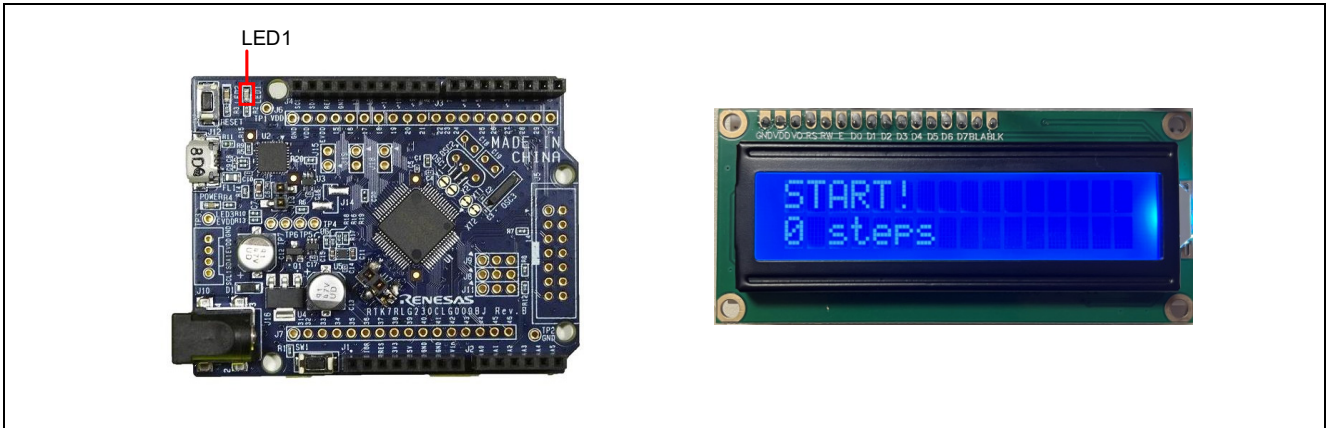

- 6. To end the counting steps, press the user switch. After that, the LED1 turns off and LED2 turns on, showing that the system is off. If you want to record again, please either restart the power or press the reset switch.

Figure 4-13 Position of the LED1 and switches and the display of the LCD module when ending the counting

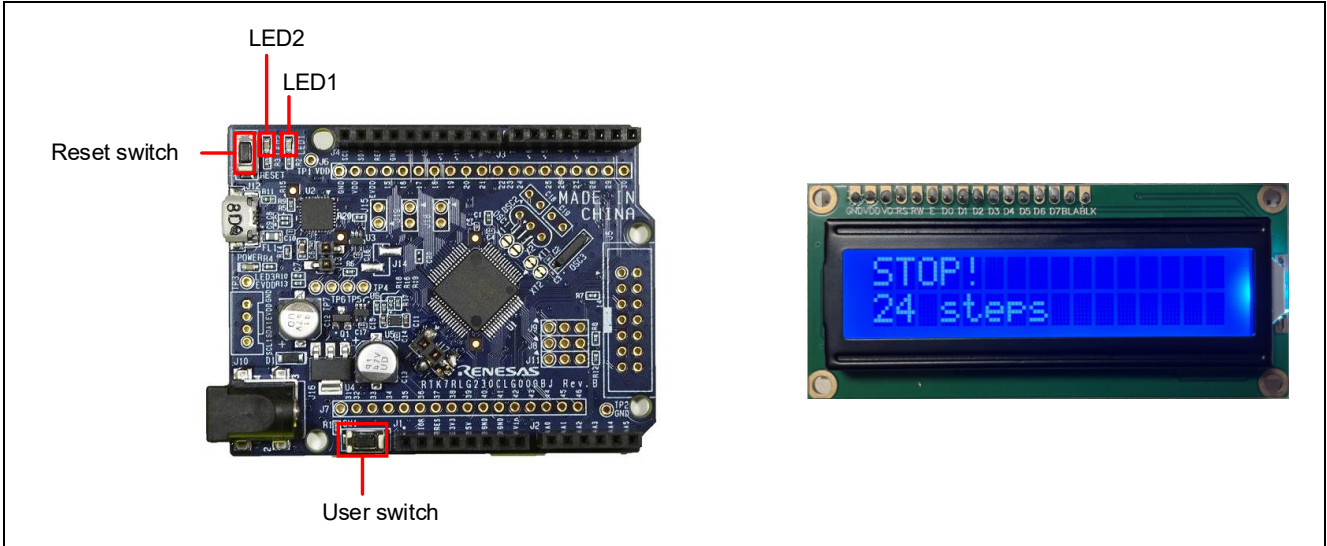

4.5 Flowchart

4.5.1 main processing

The flow of the sample sketch is shown below.

Figure 4-14 Flowchart of main processing (1/2)

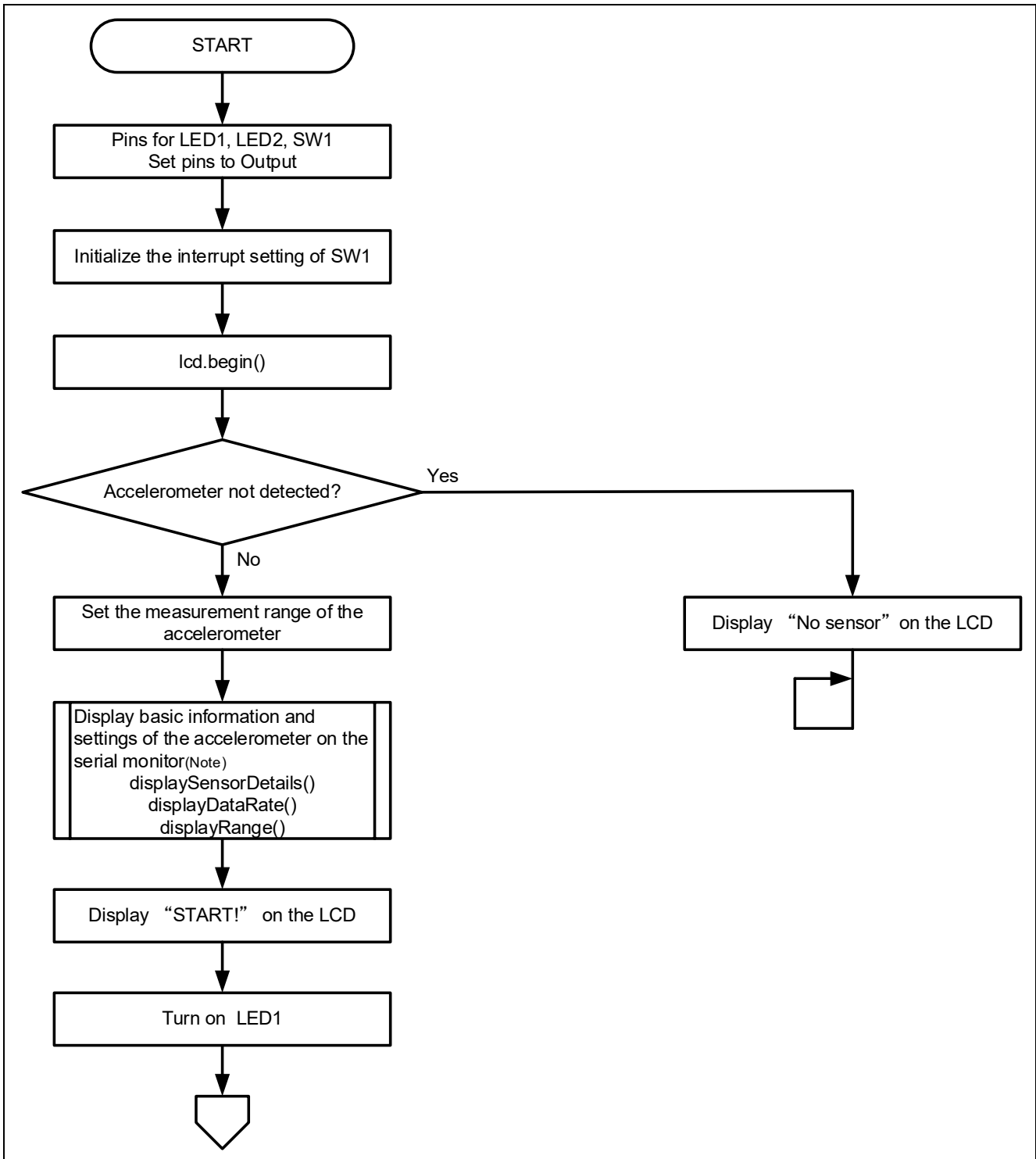

(Note) `displaySensorDetails()`, `displayDataRate()`, and `displayRange()` are the API functions provided by Adafruit_ADXL345 library. For the description of each function, refer to '4.3 API functions.' For the display content shown in the serial monitor, refer to '4.1 Overview of sample code.'

Figure 4-15 Flowchart of main processing (2/2)

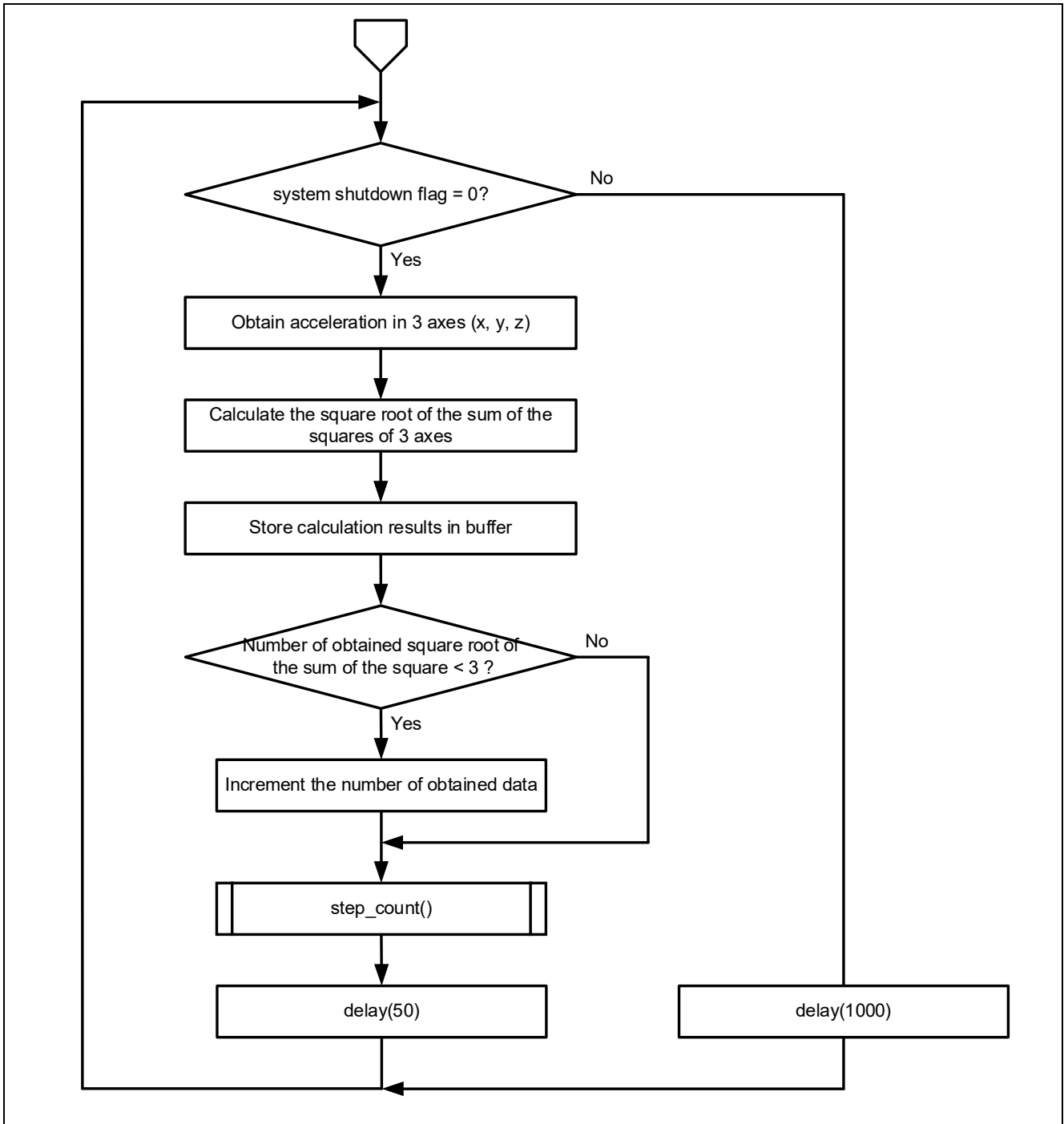

Remark. After specifying a HALT mode by “stop_system” function, when “delay(1000)” is executed, the FPB transmits to HALT mode and returns to the normal mode after 1000 milliseconds.

4.5.2 Sub routine

The flow of processing of functions called from the loop function is shown below.

(1) Count steps processing: step_count:

Figure 4-16 Flowchart of step_count

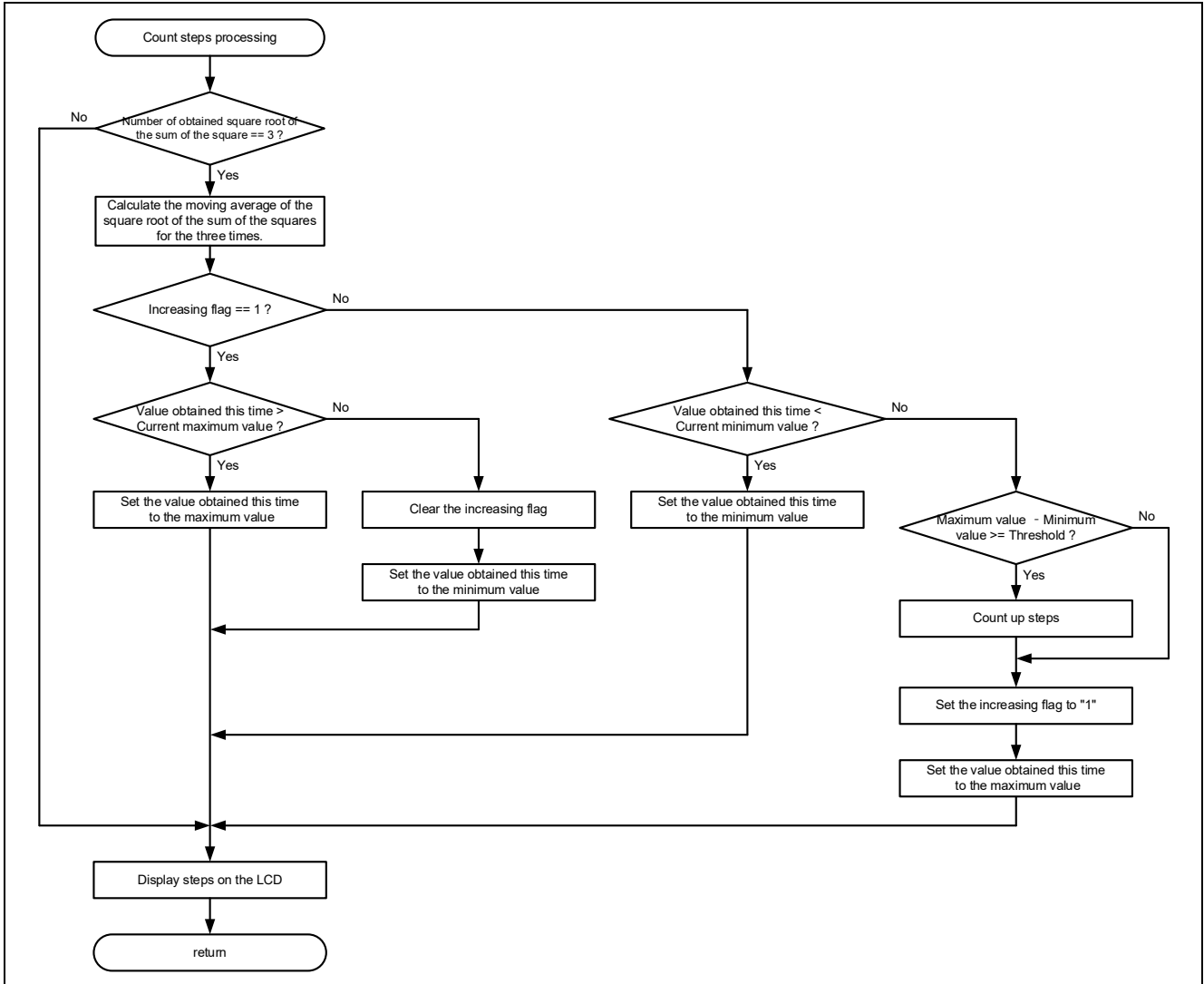

(2) End counting steps processing: stop_system:

Figure 4-17 Flowchart of stop_system

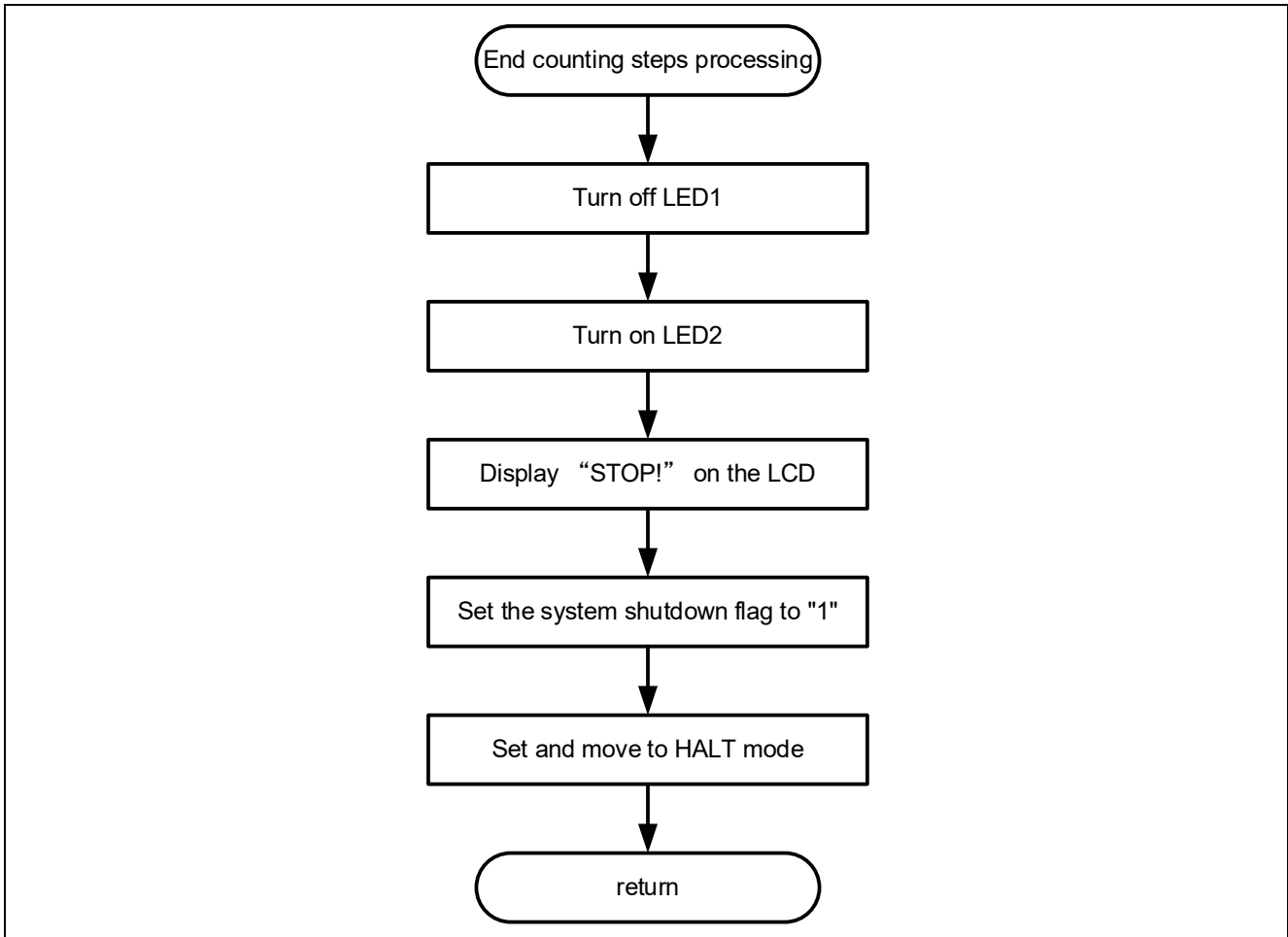

4.5.3 Specification of functions

The details of the sub routine are as follows.

void step_count(void)

Outline	Step counting process. Perform the moving average of the collected acceleration data for the X, Y, and Z axis. Based on that result, detect the fluctuations in acceleration, and count the steps.
Argument	None
Return value	None

void stop_system (void)

Outline	Ending step counting process. This is the function called by attachInterrupt when the switch is pressed. It displays 'STOP!' on the LCD module, set the system shutdown flag, and configures the HALT mode.
Argument	None
Return value	None

5. Notes

5.1 COM port is not displayed on the Windows Device Manager

When connecting the PC and the evaluation board (RL78/G23-64p FPB) for the first time, the PC may not recognize the port, and the COM port may not be displayed in Windows Device Manager.

If the COM port is not displayed, install the driver of the USB-to-serial converter (FT232RQ) from FTDI on the RL78/G23-64p FPB by the following procedure.

1. Download the latest driver installer for the target OS from FTDI's website and install it.
<https://ftdichip.com/drivers/vcp-drivers/>
2. After installation, "USB Serial Port (COMx)" is displayed under the "Ports (COM & LPT)" on the Device Manager. In the following figure, COM5 is the target COM port.

Figure 5-1 Windows Device Manager after installation of device driver

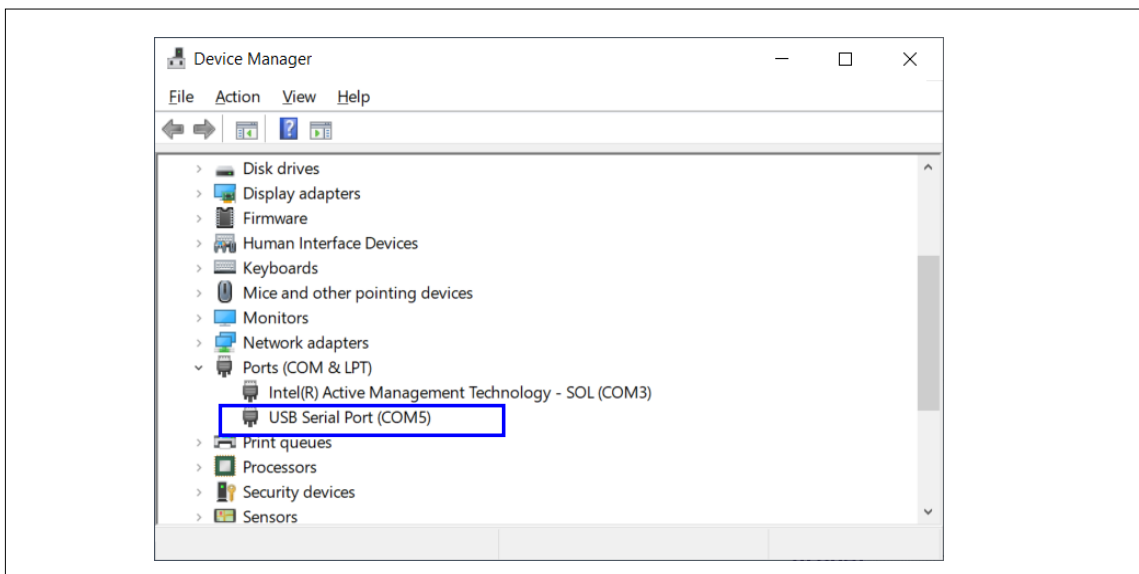

For details of USB-to-serial connector and COM port, refer to "5.11 USB-to-Serial Converter" and "5.12 USB-to-Serial Converter Reset Header" in RL78/G23-64p Fast Prototyping Board User's manual.

5.2 Program is not written correctly to RL78/G23-64p Fast Prototyping Board

It may not be connected correctly to the PC and the RL78/G23-64p FPB even if “USB Serial Port (COMx)” is displayed. Because the RL78/G23-64p FPB is not recognized correctly.

If the program is not written correctly, double-click the target COM port on Windows Device Manager and clear the checkbox of [Serial Emulator].

Figure 5-2 Setting example of target COM

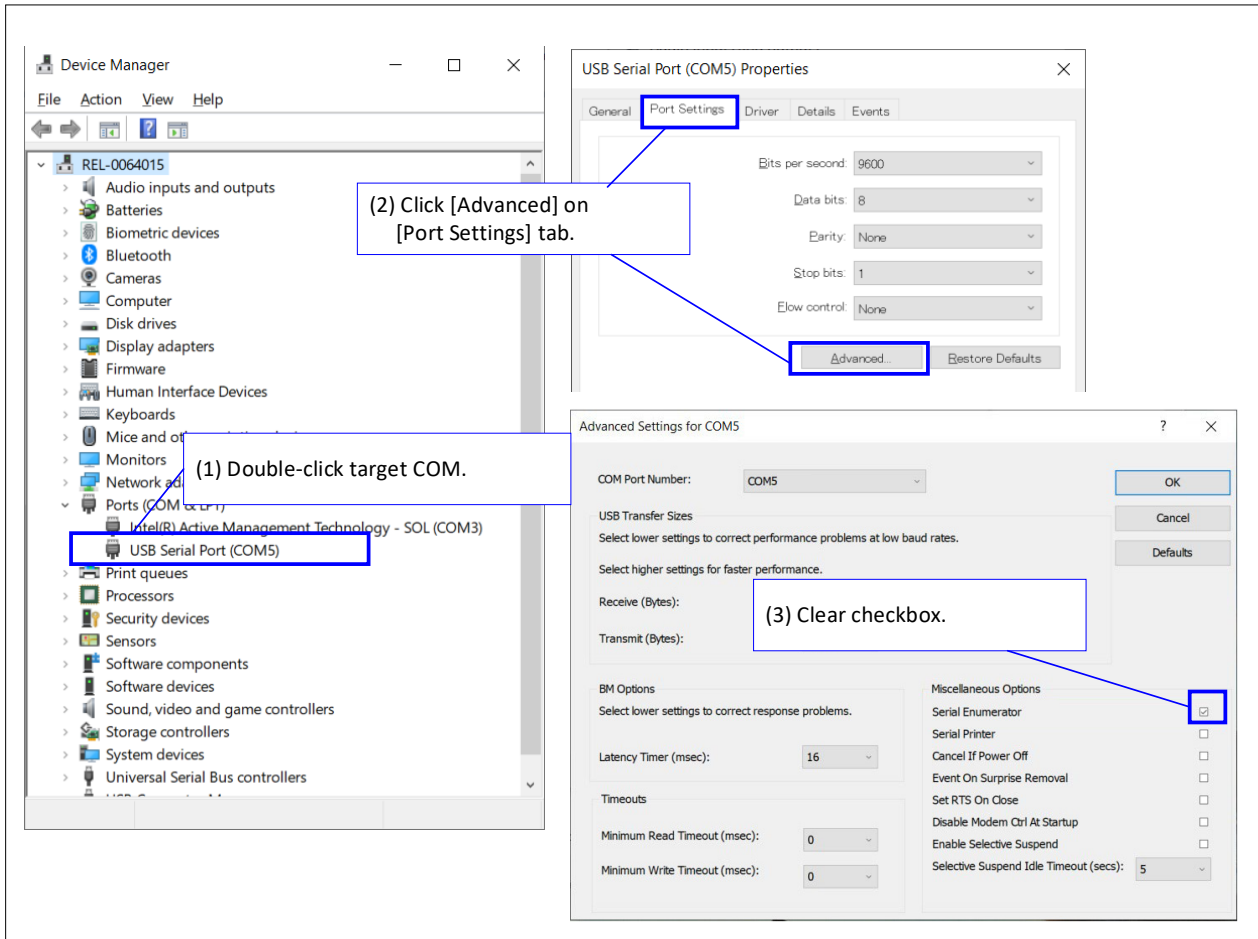

5.3 After the power supply by the mobile battery is started, it immediately stops

It is possible to use the mobile battery with the auto power-off function.

When powering a board that operates on a weak current like that of an FPB with a standard mobile battery, the protection function (auto power-off function) may activate, and stopping the power supply. Therefore, please use a mobile battery that does not automatically turn off.

6. Sample Code

There is the sample code for this application note.

Sample code can be downloaded from the Renesas Electronics website.

7. Reference Documents

RL78/G23 User's Manual: Hardware (R01UH0896)

RL78/G23-64p Fast Prototyping Board User's Manual (R20UT4814)

The latest versions can be downloaded from the Renesas Electronics website.

Technical update

The latest versions can be downloaded from the Renesas Electronics website.

All trademarks and registered trademarks are the property of their respective owners.

Revision History

Rev.	Date	Description	
		Page	Summary
1.00	Oct.29.24	-	First edition

General Precautions in the Handling of Microprocessing Unit and Microcontroller Unit Products

The following usage notes are applicable to all Microprocessing unit and Microcontroller unit products from Renesas. For detailed usage notes on the products covered by this document, refer to the relevant sections of the document as well as any technical updates that have been issued for the products.

1. Precaution against Electrostatic Discharge (ESD)

A strong electrical field, when exposed to a CMOS device, can cause destruction of the gate oxide and ultimately degrade the device operation. Steps must be taken to stop the generation of static electricity as much as possible, and quickly dissipate it when it occurs. Environmental control must be adequate. When it is dry, a humidifier should be used. This is recommended to avoid using insulators that can easily build up static electricity.

Semiconductor devices must be stored and transported in an anti-static container, static shielding bag or conductive material. All test and measurement tools including work benches and floors must be grounded. The operator must also be grounded using a wrist strap. Semiconductor devices must not be touched with bare hands. Similar precautions must be taken for printed circuit boards with mounted semiconductor devices.

2. Processing at power-on

The state of the product is undefined at the time when power is supplied. The states of internal circuits in the LSI are indeterminate and the states of register settings and pins are undefined at the time when power is supplied. In a finished product where the reset signal is applied to the external reset pin, the states of pins are not guaranteed from the time when power is supplied until the reset process is completed. In a similar way, the states of pins in a product that is reset by an on-chip power-on reset function are not guaranteed from the time when power is supplied until the power reaches the level at which resetting is specified.

3. Input of signal during power-off state

Do not input signals or an I/O pull-up power supply while the device is powered off. The current injection that results from input of such a signal or I/O pull-up power supply may cause malfunction and the abnormal current that passes in the device at this time may cause degradation of internal elements. Follow the guideline for input signal during power-off state as described in your product documentation.

4. Handling of unused pins

Handle unused pins in accordance with the directions given under handling of unused pins in the manual. The input pins of CMOS products are generally in the high-impedance state. In operation with an unused pin in the open-circuit state, extra electromagnetic noise is induced in the vicinity of the LSI, an associated shoot-through current flows internally, and malfunctions occur due to the false recognition of the pin state as an input signal become possible.

5. Clock signals

After applying a reset, only release the reset line after the operating clock signal becomes stable. When switching the clock signal during program execution, wait until the target clock signal is stabilized. When the clock signal is generated with an external resonator or from an external oscillator during a reset, ensure that the reset line is only released after full stabilization of the clock signal. Additionally, when switching to a clock signal produced with an external resonator or by an external oscillator while program execution is in progress, wait until the target clock signal is stable.

6. Voltage application waveform at input pin

Waveform distortion due to input noise or a reflected wave may cause malfunction. If the input of the CMOS device stays in the area between V_{IL} (Max.) and V_{IH} (Min.) due to noise, for example, the device may malfunction. Take care to prevent chattering noise from entering the device when the input level is fixed, and also in the transition period when the input level passes through the area between V_{IL} (Max.) and V_{IH} (Min.).

7. Prohibition of access to reserved addresses

Access to reserved addresses is prohibited. The reserved addresses are provided for possible future expansion of functions. Do not access these addresses as the correct operation of the LSI is not guaranteed.

8. Differences between products

Before changing from one product to another, for example to a product with a different part number, confirm that the change will not lead to problems. The characteristics of a microprocessing unit or microcontroller unit products in the same group but having a different part number might differ in terms of internal memory capacity, layout pattern, and other factors, which can affect the ranges of electrical characteristics, such as characteristic values, operating margins, immunity to noise, and amount of radiated noise. When changing to a product with a different part number, implement a system-evaluation test for the given product.

Notice

1. Descriptions of circuits, software and other related information in this document are provided only to illustrate the operation of semiconductor products and application examples. You are fully responsible for the incorporation or any other use of the circuits, software, and information in the design of your product or system. Renesas Electronics disclaims any and all liability for any losses and damages incurred by you or third parties arising from the use of these circuits, software, or information.
2. Renesas Electronics hereby expressly disclaims any warranties against and liability for infringement or any other claims involving patents, copyrights, or other intellectual property rights of third parties, by or arising from the use of Renesas Electronics products or technical information described in this document, including but not limited to, the product data, drawings, charts, programs, algorithms, and application examples.
3. No license, express, implied or otherwise, is granted hereby under any patents, copyrights or other intellectual property rights of Renesas Electronics or others.
4. You shall be responsible for determining what licenses are required from any third parties, and obtaining such licenses for the lawful import, export, manufacture, sales, utilization, distribution or other disposal of any products incorporating Renesas Electronics products, if required.
5. You shall not alter, modify, copy, or reverse engineer any Renesas Electronics product, whether in whole or in part. Renesas Electronics disclaims any and all liability for any losses or damages incurred by you or third parties arising from such alteration, modification, copying or reverse engineering.
6. Renesas Electronics products are classified according to the following two quality grades: "Standard" and "High Quality". The intended applications for each Renesas Electronics product depends on the product's quality grade, as indicated below.
 - "Standard": Computers; office equipment; communications equipment; test and measurement equipment; audio and visual equipment; home electronic appliances; machine tools; personal electronic equipment; industrial robots; etc.
 - "High Quality": Transportation equipment (automobiles, trains, ships, etc.); traffic control (traffic lights); large-scale communication equipment; key financial terminal systems; safety control equipment; etc.

Unless expressly designated as a high reliability product or a product for harsh environments in a Renesas Electronics data sheet or other Renesas Electronics document, Renesas Electronics products are not intended or authorized for use in products or systems that may pose a direct threat to human life or bodily injury (artificial life support devices or systems; surgical implantations; etc.), or may cause serious property damage (space system; undersea repeaters; nuclear power control systems; aircraft control systems; key plant systems; military equipment; etc.). Renesas Electronics disclaims any and all liability for any damages or losses incurred by you or any third parties arising from the use of any Renesas Electronics product that is inconsistent with any Renesas Electronics data sheet, user's manual or other Renesas Electronics document.
7. No semiconductor product is absolutely secure. Notwithstanding any security measures or features that may be implemented in Renesas Electronics hardware or software products, Renesas Electronics shall have absolutely no liability arising out of any vulnerability or security breach, including but not limited to any unauthorized access to or use of a Renesas Electronics product or a system that uses a Renesas Electronics product. RENESAS ELECTRONICS DOES NOT WARRANT OR GUARANTEE THAT RENESAS ELECTRONICS PRODUCTS, OR ANY SYSTEMS CREATED USING RENESAS ELECTRONICS PRODUCTS WILL BE INVULNERABLE OR FREE FROM CORRUPTION, ATTACK, VIRUSES, INTERFERENCE, HACKING, DATA LOSS OR THEFT, OR OTHER SECURITY INTRUSION ("Vulnerability Issues"). RENESAS ELECTRONICS DISCLAIMS ANY AND ALL RESPONSIBILITY OR LIABILITY ARISING FROM OR RELATED TO ANY VULNERABILITY ISSUES. FURTHERMORE, TO THE EXTENT PERMITTED BY APPLICABLE LAW, RENESAS ELECTRONICS DISCLAIMS ANY AND ALL WARRANTIES, EXPRESS OR IMPLIED, WITH RESPECT TO THIS DOCUMENT AND ANY RELATED OR ACCOMPANYING SOFTWARE OR HARDWARE, INCLUDING BUT NOT LIMITED TO THE IMPLIED WARRANTIES OF MERCHANTABILITY, OR FITNESS FOR A PARTICULAR PURPOSE.
8. When using Renesas Electronics products, refer to the latest product information (data sheets, user's manuals, application notes, "General Notes for Handling and Using Semiconductor Devices" in the reliability handbook, etc.), and ensure that usage conditions are within the ranges specified by Renesas Electronics with respect to maximum ratings, operating power supply voltage range, heat dissipation characteristics, installation, etc. Renesas Electronics disclaims any and all liability for any malfunctions, failure or accident arising out of the use of Renesas Electronics products outside of such specified ranges.
9. Although Renesas Electronics endeavors to improve the quality and reliability of Renesas Electronics products, semiconductor products have specific characteristics, such as the occurrence of failure at a certain rate and malfunctions under certain use conditions. Unless designated as a high reliability product or a product for harsh environments in a Renesas Electronics data sheet or other Renesas Electronics document, Renesas Electronics products are not subject to radiation resistance design. You are responsible for implementing safety measures to guard against the possibility of bodily injury, injury or damage caused by fire, and/or danger to the public in the event of a failure or malfunction of Renesas Electronics products, such as safety design for hardware and software, including but not limited to redundancy, fire control and malfunction prevention, appropriate treatment for aging degradation or any other appropriate measures. Because the evaluation of microcomputer software alone is very difficult and impractical, you are responsible for evaluating the safety of the final products or systems manufactured by you.
10. Please contact a Renesas Electronics sales office for details as to environmental matters such as the environmental compatibility of each Renesas Electronics product. You are responsible for carefully and sufficiently investigating applicable laws and regulations that regulate the inclusion or use of controlled substances, including without limitation, the EU RoHS Directive, and using Renesas Electronics products in compliance with all these applicable laws and regulations. Renesas Electronics disclaims any and all liability for damages or losses occurring as a result of your noncompliance with applicable laws and regulations.
11. Renesas Electronics products and technologies shall not be used for or incorporated into any products or systems whose manufacture, use, or sale is prohibited under any applicable domestic or foreign laws or regulations. You shall comply with any applicable export control laws and regulations promulgated and administered by the governments of any countries asserting jurisdiction over the parties or transactions.
12. It is the responsibility of the buyer or distributor of Renesas Electronics products, or any other party who distributes, disposes of, or otherwise sells or transfers the product to a third party, to notify such third party in advance of the contents and conditions set forth in this document.
13. This document shall not be reprinted, reproduced or duplicated in any form, in whole or in part, without prior written consent of Renesas Electronics.
14. Please contact a Renesas Electronics sales office if you have any questions regarding the information contained in this document or Renesas Electronics products.

(Note1) "Renesas Electronics" as used in this document means Renesas Electronics Corporation and also includes its directly or indirectly controlled subsidiaries.

(Note2) "Renesas Electronics product(s)" means any product developed or manufactured by or for Renesas Electronics.

(Rev.5.0-1 October 2020)

Corporate Headquarters

TOYOSU FORESIA, 3-2-24 Toyosu,
Koto-ku, Tokyo 135-0061, Japan
www.renesas.com

Trademarks

Renesas and the Renesas logo are trademarks of Renesas Electronics Corporation. All trademarks and registered trademarks are the property of their respective owners.

Contact information

For further information on a product, technology, the most up-to-date version of a document, or your nearest sales office, please visit:
www.renesas.com/contact/.