

RL78/G24

Flexible Application Accelerator (FAA) Tool Guide: e2 studio

Introduction

This guide describes the options that must be set for the build process and debugger of the flexible application accelerator (FAA) contained in RL78/G24. It also describes how to operate the debugger.

Target Device

RL78/G24

RL78/G24 Fast Prototyping Board

Chapter Composition

Chapter 1: Overview of Flexible Application Accelerator (FAA)

This chapter describes the overview of the flexible application accelerator (FAA) and program creation.

Chapter 2: Overview of build process and debugger of Flexible Application Accelerator (FAA)

This chapter describes the new project creation procedure and the options that must be set for the build process and debugger of the flexible application accelerator (FAA). It also describes how to operate the debugger.

Chapter 3: Debugger operation using sample project

This chapter describes debugging operations for FAA programs using the sample code.

Related Documents

- RL78/G24 User's Manual: Hardware (R01UH0961)
- RL78/G24 Fast Prototyping Board User's Manual (R20UT5091)

Contents

1. Overview	4
1.1 Flexible Application Accelerator (FAA).....	4
1.2 Internal Memory Space of FAA	4
1.3 Program for RL78/G24	5
1.3.1 Program Structure	5
1.3.2 Transfer of Program and Data for FAA	6
1.3.3 FAA Program.....	6
1.3.4 Build Process and Debug of FAA Program	7
2. Option Setting and Operation	8
2.1 Operating Environment	8
2.2 Project Creation.....	9
2.3 Adding FAA Program.....	13
2.3.1 Adding FAA Component.....	13
2.3.2 Overview of FAA library's File Structure	22
2.4 Build Tool Option Setting.....	23
2.4.1 FAA Assembler Options	24
2.4.2 Linker Options	26
2.4.3 Program Building	28
2.5 Debug Tool Option Setting	30
2.5.1 Debugger Options	31
2.5.2 Startup Options.....	31
2.5.3 Program Download.....	34
2.6 FAA Program Debug	35
2.6.1 Debug Target.....	35
2.6.2 Source File Display	36
2.6.3 Run / Stop.....	37
2.6.4 Breakpoint	39
2.6.5 Memory.....	40
2.6.6 Symbol (Label)	42
2.6.7 Register	43
2.6.8 IO Register(SFR).....	44
3. Sample Project	45
3.1 Specifications	45
3.1.1 Specification Overview	45
3.1.2 Operation Overview.....	46
3.2 Operation Confirmation Conditions	47
3.3 Hardware Description	48
3.3.1 Example of Hardware Configuration	48

3.3.2	List of Used Pins.....	48
3.4	Software Description	49
3.4.1	Smart Configurator Setting.....	49
3.4.1.1	Clock.....	49
3.4.1.2	System.....	50
3.4.1.3	Component.....	50
3.4.2	Folder Structure.....	53
3.4.3	Option Byte Settings.....	53
3.4.4	List of Constants.....	54
3.4.5	List of Variables	54
3.4.6	List of Functions	55
3.4.7	Function Specification	55
3.4.8	Flowchart.....	56
3.4.8.1	Main Process.....	56
3.4.8.2	r_Config_TKB0_end_count_interrupt Function.....	57
3.4.8.3	FAA Processing.....	58
3.5	Basic debug operations.....	59
4.	Sample Code.....	62
5.	Reference Documents.....	62
	Revision History.....	63

1. Overview

1.1 Flexible Application Accelerator (FAA)

The flexible application accelerator (FAA) contained in RL78/G24 is a Renesas original application accelerator with a Harvard architecture. It can execute 32-bit multiplication, addition, and subtraction in a single cycle.

FAA can access some peripheral functions directly by the address bus select function. Operations by the CPU and FAA can be combined to suit the application, it can improve operation efficiency of the system.

Figure 1-1 Image diagram of RL78/G24 FAA

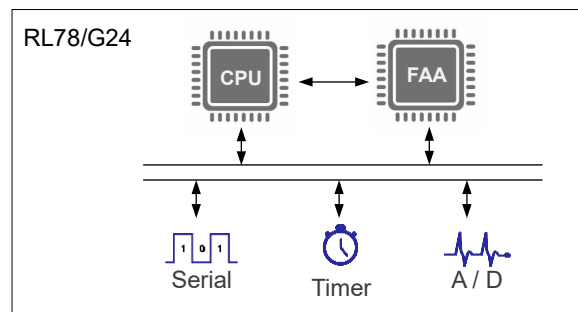

1.2 Internal Memory Space of FAA

When the FAA is in use, some of the RL78/G24's internal RAM is dedicated to the FAA.

Instruction Code Memory: Store the program for FAA

Data Memory: Store the data for FAA

Figure 1-2 Memory Map of the Instruction Code Memory and Data Memory

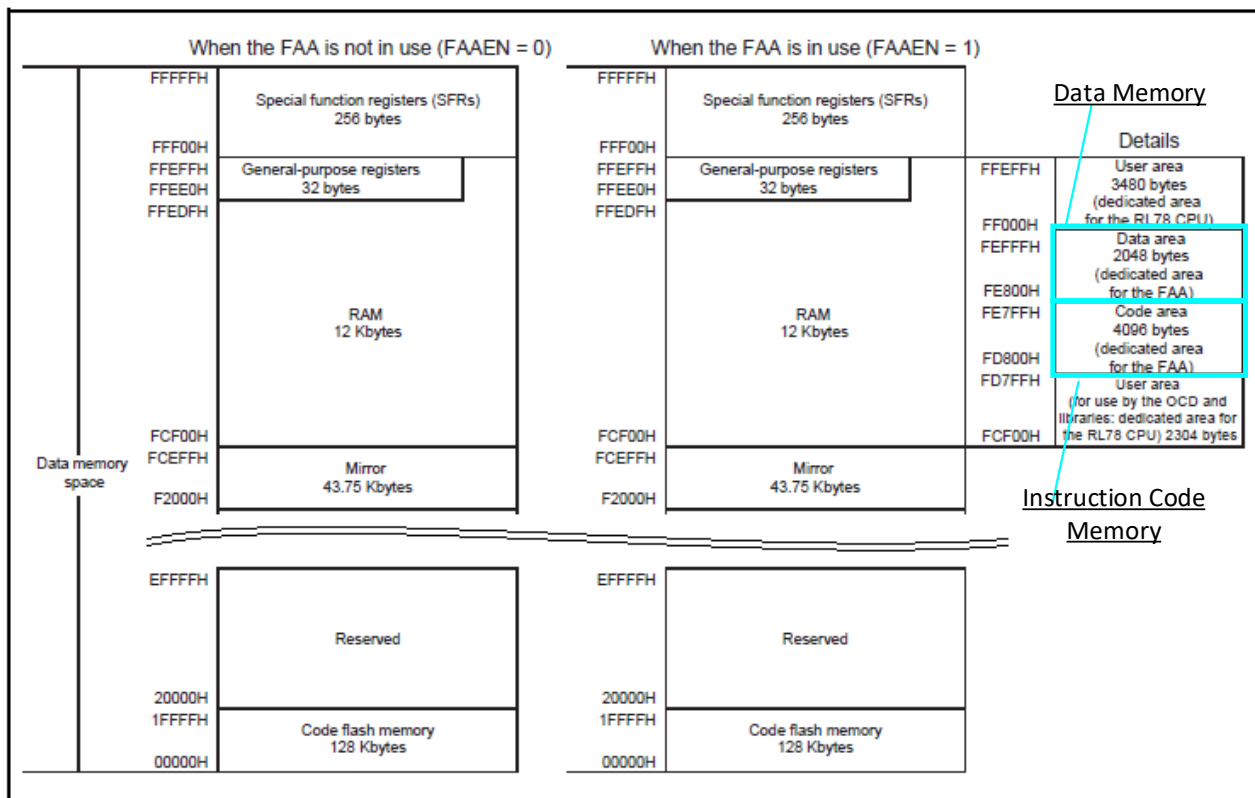

1.3 Program for RL78/G24

1.3.1 Program Structure

Programs for the CPU and programs for the FAA are coded in separate files. FAA programs use the FAA-dedicated instruction sets. CPU programs and FAA programs are built together in an object file (load module file) that can be executed in RL78/G24.

Figure 1-3 Program structure when FAA is in use

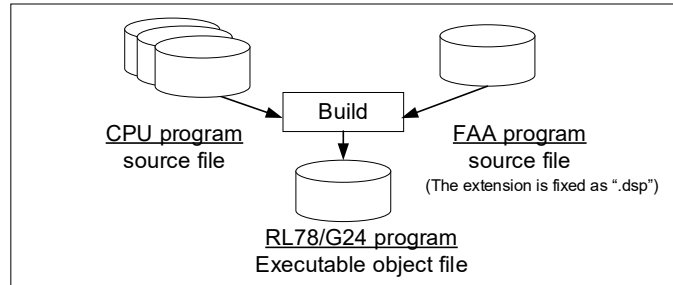
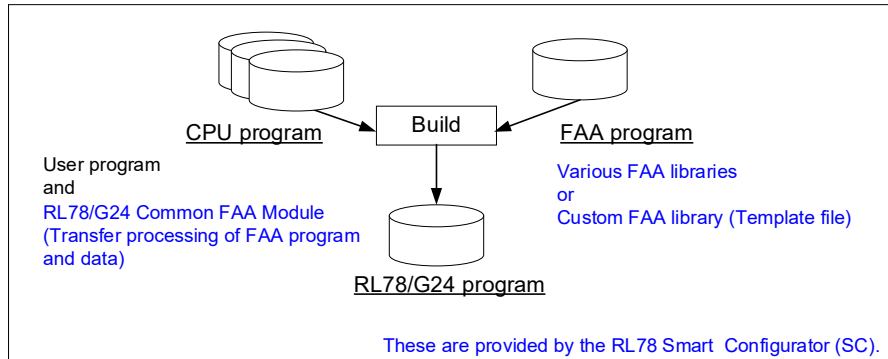

Figure 1-4 FAA related files provided by the RL78 Smart Configurator



Remark. If you do not use the FAA program and data transfer processing, and template file provided by the SC, you will need to prepare your own program.

1.3.2 Transfer of Program and Data for FAA

An executable object file is written to the RL78/G24 code flash memory. However, FAA programs must be placed in the instruction code memory and FAA data must be placed in the data memory. Therefore, before executing an FAA program (before the FAA operation is enabled), the FAA program and data stored in the code flash memory must be transferred to the instruction code memory and data memory, respectively.

The transfer processing of FAA program and data is provided by the FAA component - FAA library "RL78/G24 Common FAA Module" in the Smart Configurator for RL78. For details about how to generate the transfer processing in the SC, see 2.3 Adding FAA Program.

Figure 1-5 Transfer of the program and data for FAA

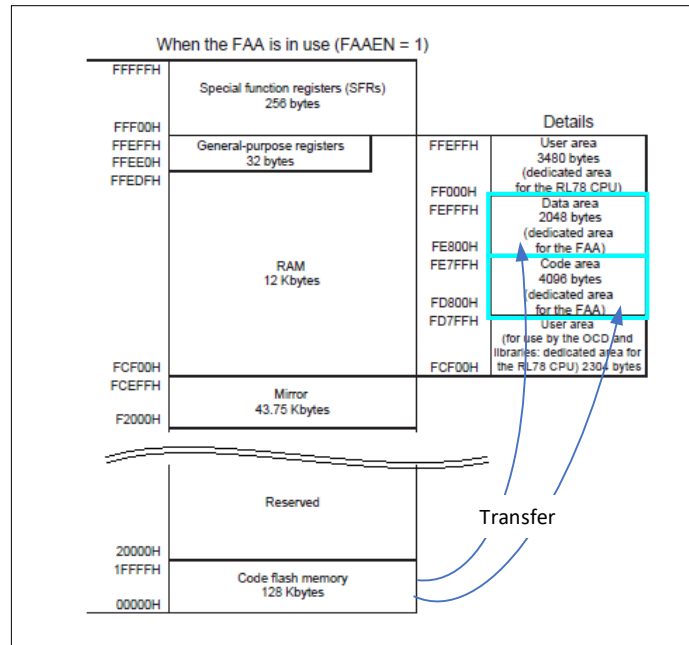

1.3.3 FAA Program

You can create an FAA program by either of the following ways:

- Use a provided FAA library according to the purpose. The library is provided in a source file in which code cannot be changed. (FAA library of various functions)
- Use a template file to code your own FAA program. (Template (Custom FAA library))

In both cases, add the FAA program to the program project by using the Smart Configurator (SC).

For details about how to use SC to output an FAA program file (library or template), see 2.3 Adding FAA Program.

Remark. For instruction sets for FAA, refer to the chapter for FAA in RL78/G24 User's Manual: Hardware (R01UH0961).

1.3.4 Build Process and Debug of FAA Program

To build and debug FAA programs, some options must be set up. This guide describes the options that must be specified for the processing shown in Figure 1-6. It also describes how to use the debugger for debugging FAA programs.

Note that this guide requires the use of FAA programs (libraries or templates) generated by the Smart Configurator (SC).

Figure 1-6 Operating instruction in chapter 2 of this guide

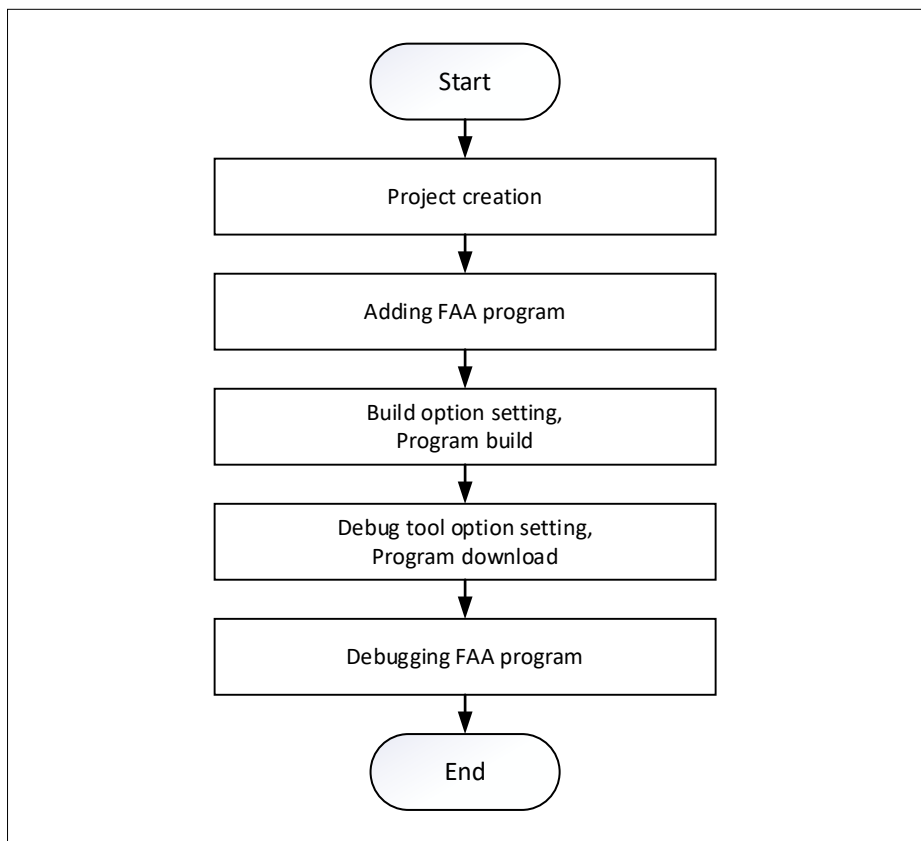

2. Option Setting and Operation

This chapter explains the option settings and debugger operation required for building and debugging an FAA program in the e2 studio environment.

For options that are not described in this guide, set them if necessary. For details about the options and operations, see the help or documentation of e2 studio.

2.1 Operating Environment

This guide uses the following tools:

Table 2-1 Software tool

Integrated development environment	Item	version
e2 studio	e2 studio Manufactured by Renesas Electronics	v2025-12
	CC-RL Manufactured by Renesas Electronics	V1.15.01
	DSPASM FAA/GREEN_DSP Structured Assembler Manufactured by Renesas Electronics	V1.05.00
	RL78 Smart Configurator Plug-in Manufactured by Renesas Electronics	The version included with e2 studio v2025-12

Table 2-2 Hardware tool

Board / Emulator	Item
Board ^{Note1}	RL78/G24 Fast Prototyping Board Manufactured by Renesas Electronics
Emulator ^{Note2}	E2 emulator Lite Manufactured by Renesas Electronics
	E2 emulator Manufactured by Renesas Electronics

Note1. Jumper settings etc. differ depending on whether the board is connected to the emulator or using COM port debugging. Please see RL78/G24 Fast Prototyping Board User's manual (R20UT5091) the instruction manual for details.

Note2. When the debugger and the RL78/G24 Fast Prototyping Board are connected via COM port, the emulator is not required.

2.2 Project Creation

Select the RL78/G24 product as the microcontroller to be used and create a program project.

Procedure:

1. Launch the e2 studio.
2. Specify the workspace directory in the [e2 studio Launcher] dialog, and then click the [Launch].

Figure 2-1 e2 studio Launcher

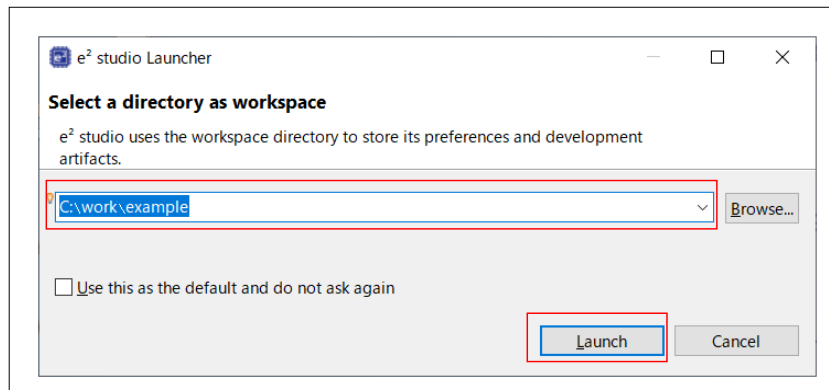

3. Select the [File] menu -> [New] -> [C/C++ Project].

Figure 2-2 [File] menu -> [New] -> [C/C++ Project]

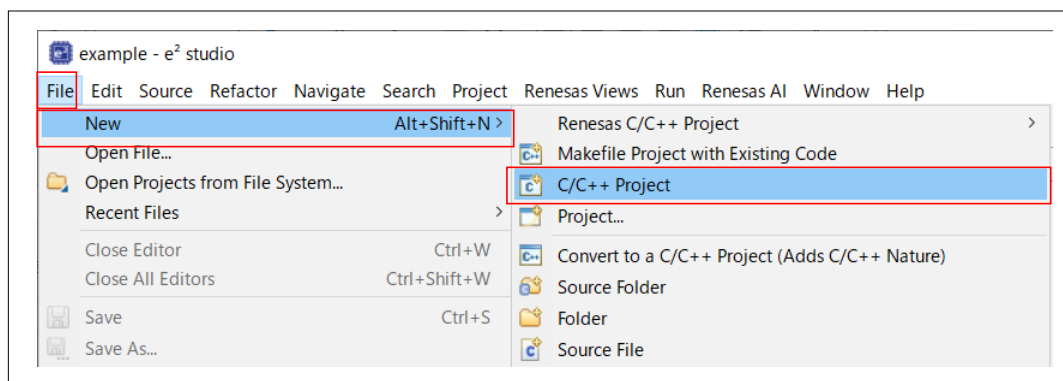

4. Select the [Renesas RL78] -> [Renesas CC-RL C/C++ Execution Project].in the [New C/C++ Project] dialog, click the [Next].

Figure 2-3 [New C/C++ Project] dialog (Selecting the template)

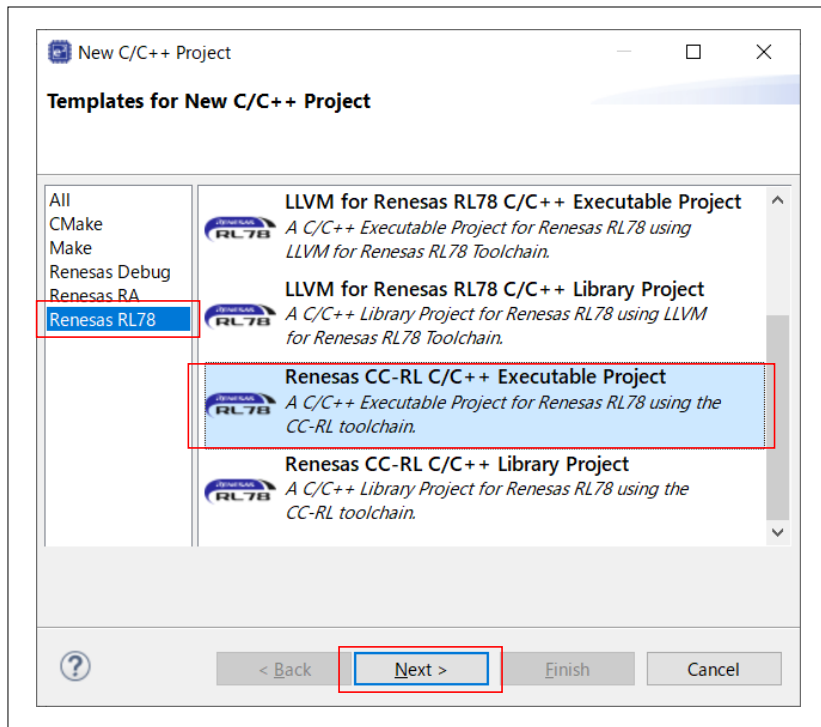

5. Select the [Renesas RL78] -> [Renesas CC-RL C/C++ Execution Project].in the [New C/C++ Project] dialog, click the [Next].

Figure 2-4 [New C/C++ Project] dialog (Specifying the file name)

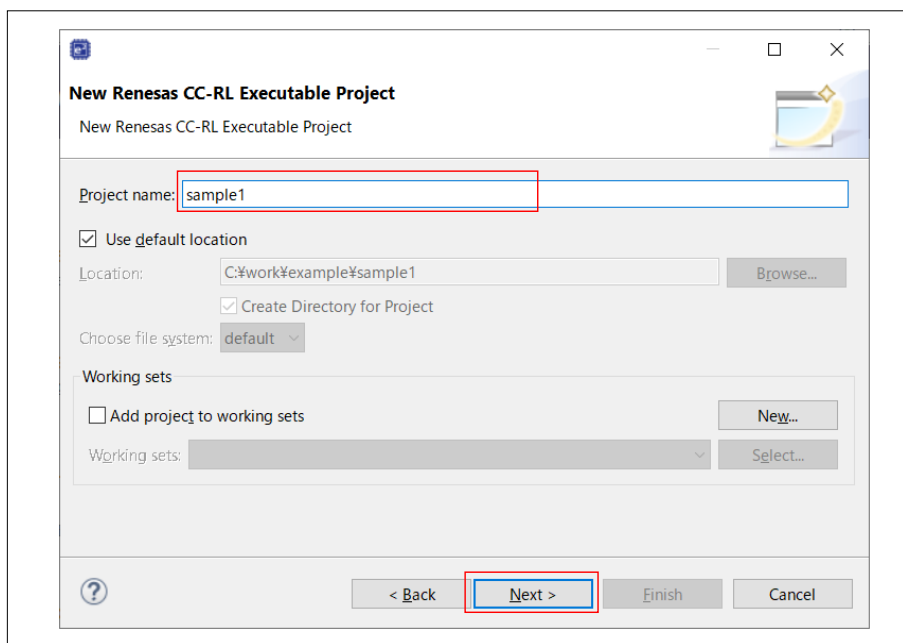

- Input "R7F101GLGxFB" at the [Target Device], click the [Next].
(Device name can be also selected from a list of device names by clicking [...].)

Figure 2-5 [New C/C++ Project] dialog (Selecting the target device)

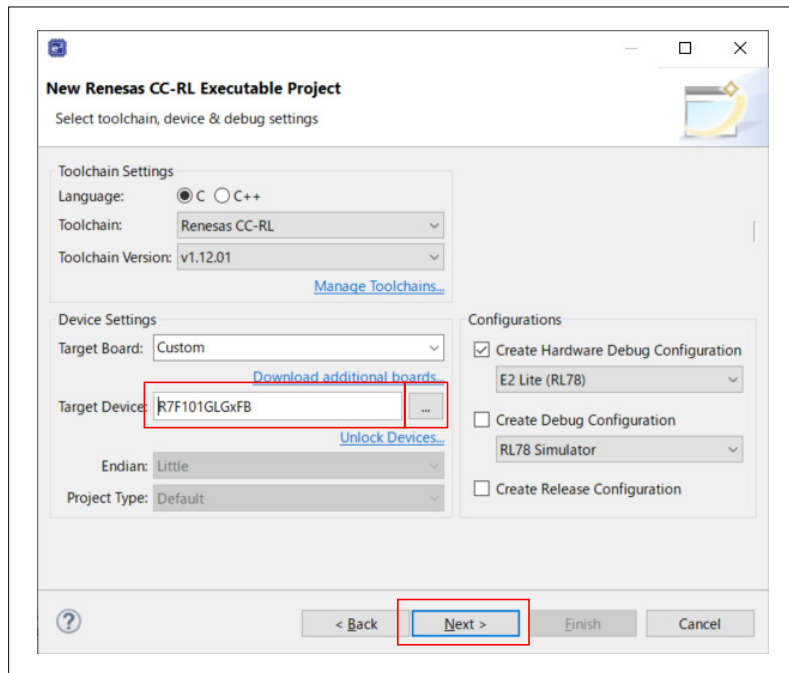

- Check the box of [Use Smart Configurator], click the [Finish].

Figure 2-6 [New C/C++ Project] dialog (Selecting the Smart Configurator)

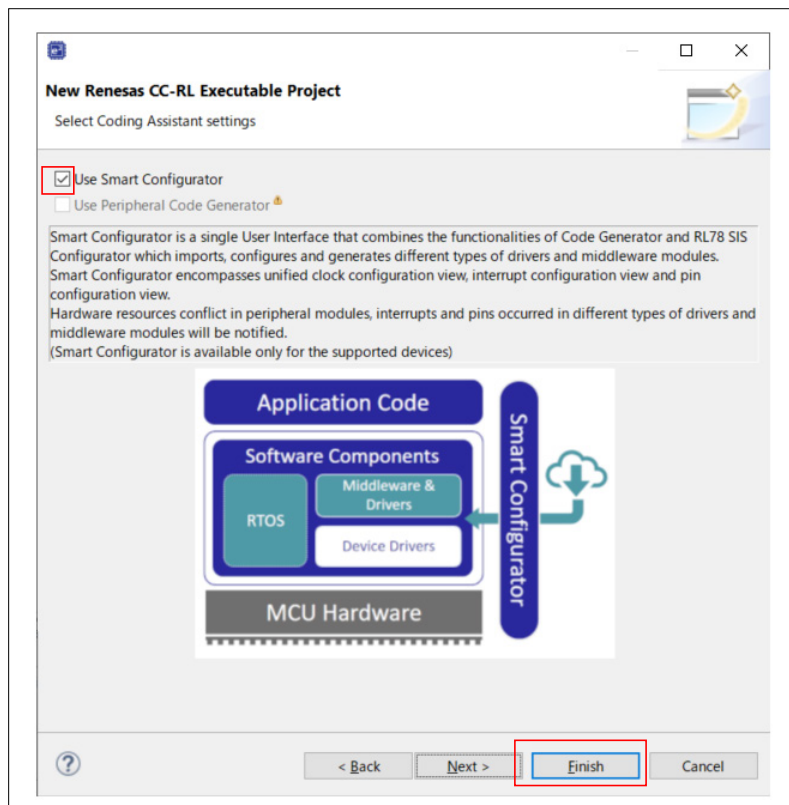

- 8. Check the [Open Perspective] in the [Open Associate Perspective?] dialog. If the [Welcome] tab is displayed at the top, click the [Hide] of the [Welcome] tab.

Figure 2-7 [Open Associate Perspective?] dialog

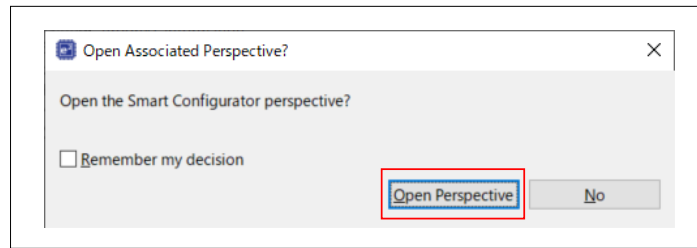
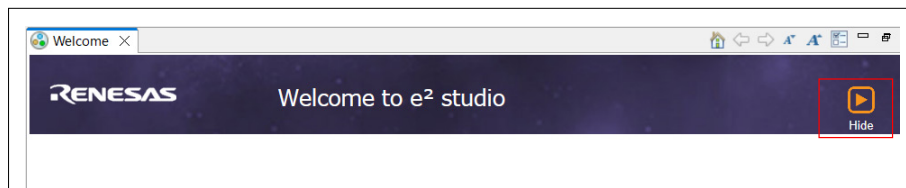
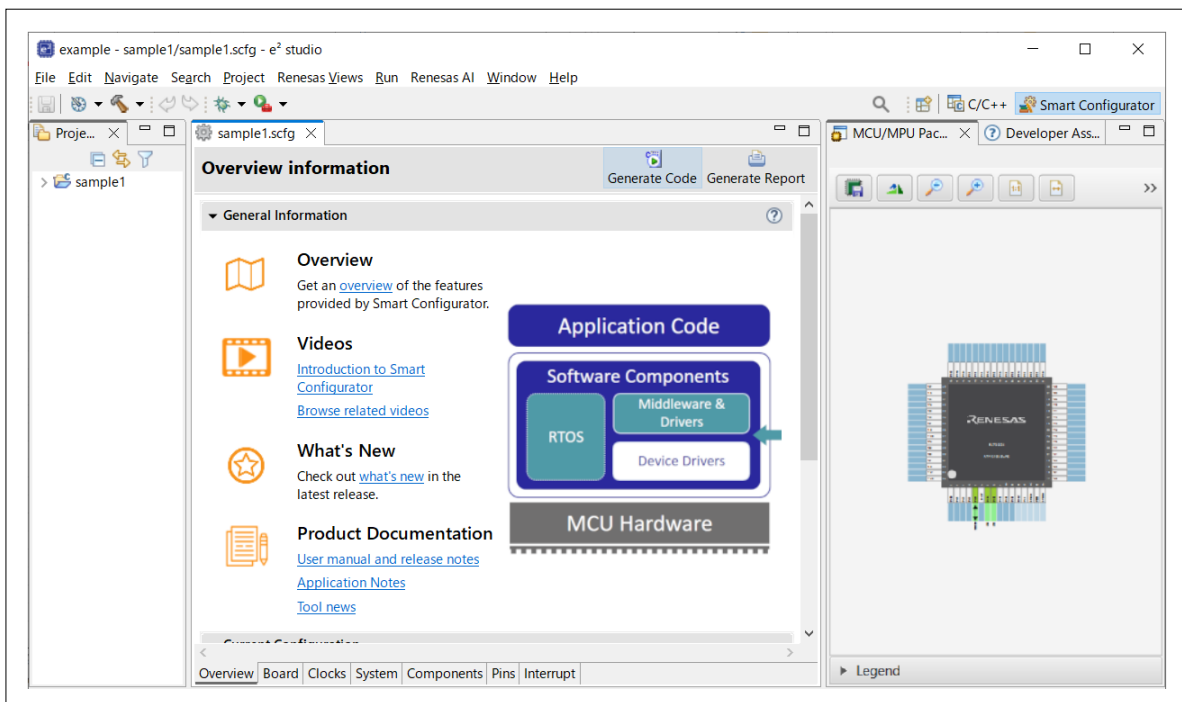

Figure 2-8 [Welcome] tab



- 9. The perspective of the Smart Configurator is displayed.

Figure 2-9 Smart Configurator perspective



2.3 Adding FAA Program

Use the Smart Configurator (SC) to add an FAA program (library or template) to your project.

This guide only describes the procedure for adding an FAA program, [Clock], [System] and [Voltage detection] that need to be set in the CPU program. Please set other peripheral functions as appropriate to suit your system.

2.3.1 Adding FAA Component

Procedure:

1. In the Smart Configurator (SC), click [Clock].

Figure 2-10 Smart Configurator: Selecting [Clock] tab

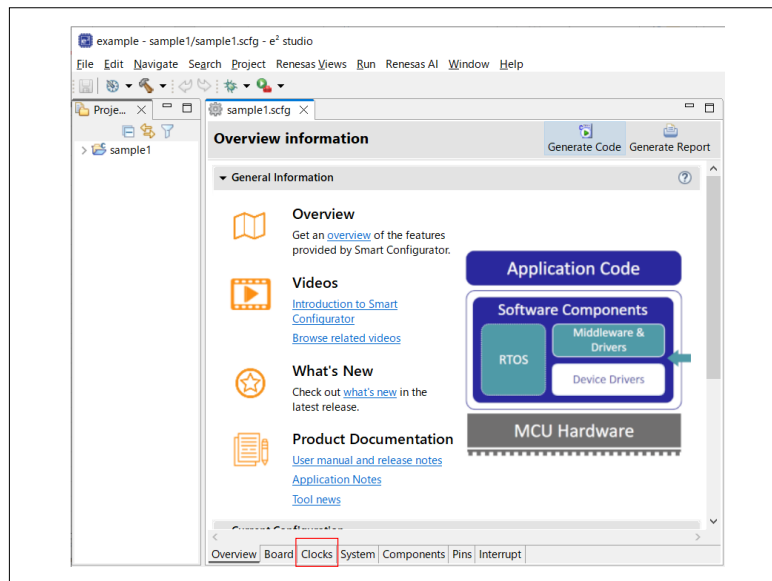

2. Set various clocks and the operation mode according to your system.

Figure 2-11 Smart Configurator: [Clock] tab

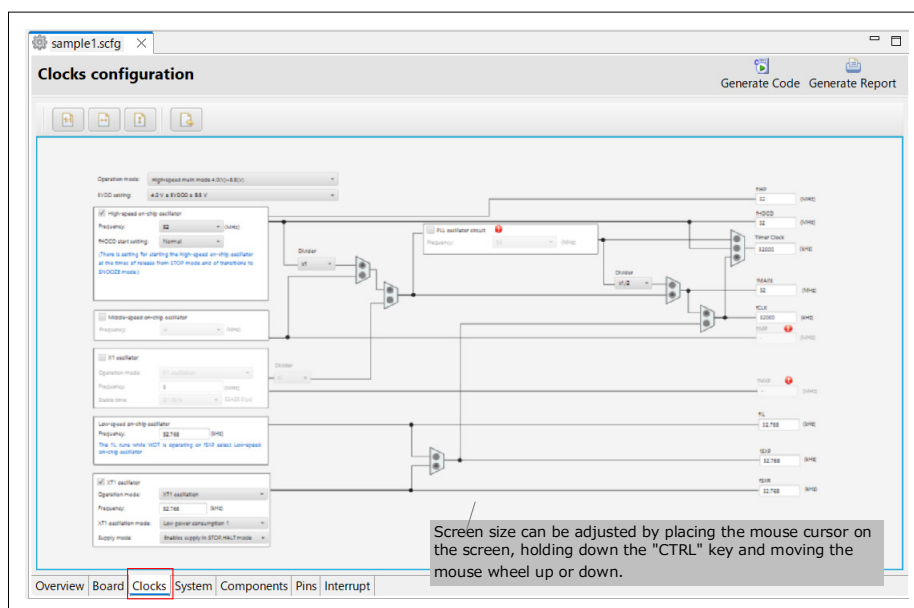

- Click the [System]. In the [System] tab, set the debug tool and functions to be used, and security ID.

Figure 2-12 Smart Configurator: [System] tab

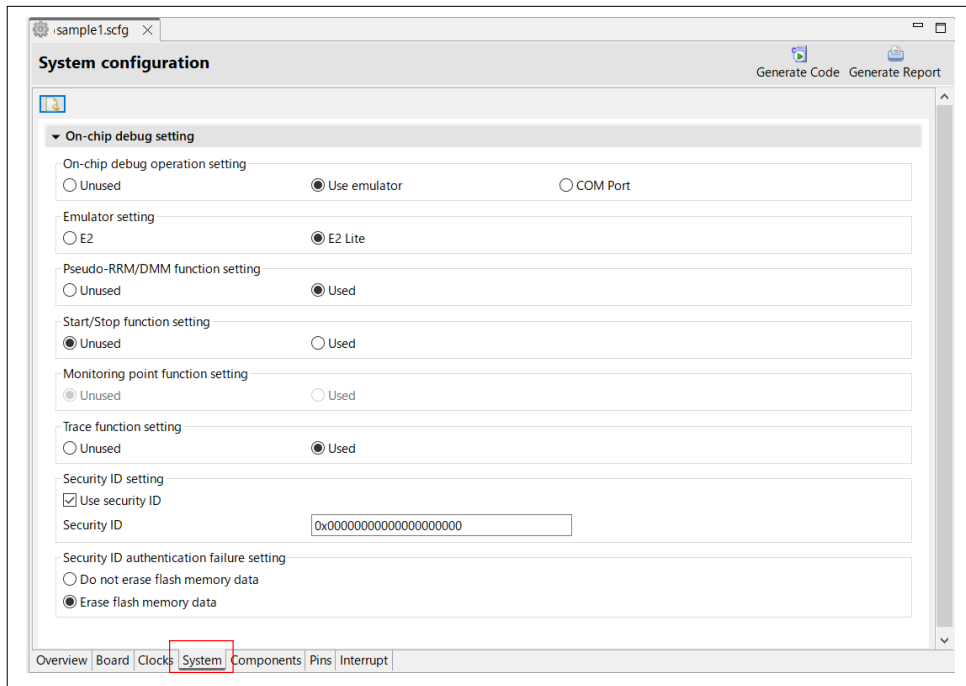

- Click the [Component]. Next, click the [Add component] to open the [New Component] dialog.

Figure 2-13 Smart Configurator: [Component] tab

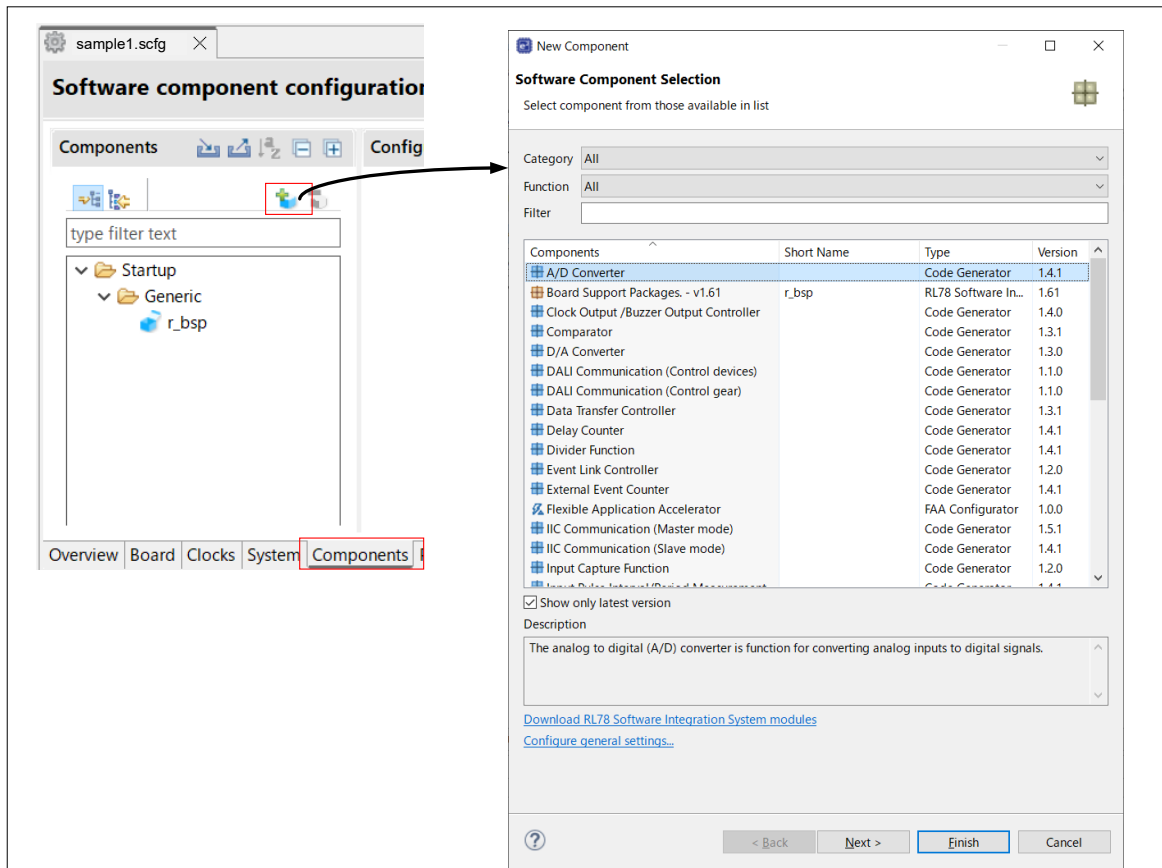

- In the [New Component] dialog, select [Voltage Detector] and click the [Next].

Figure 2-14 Select [Voltage Detector]

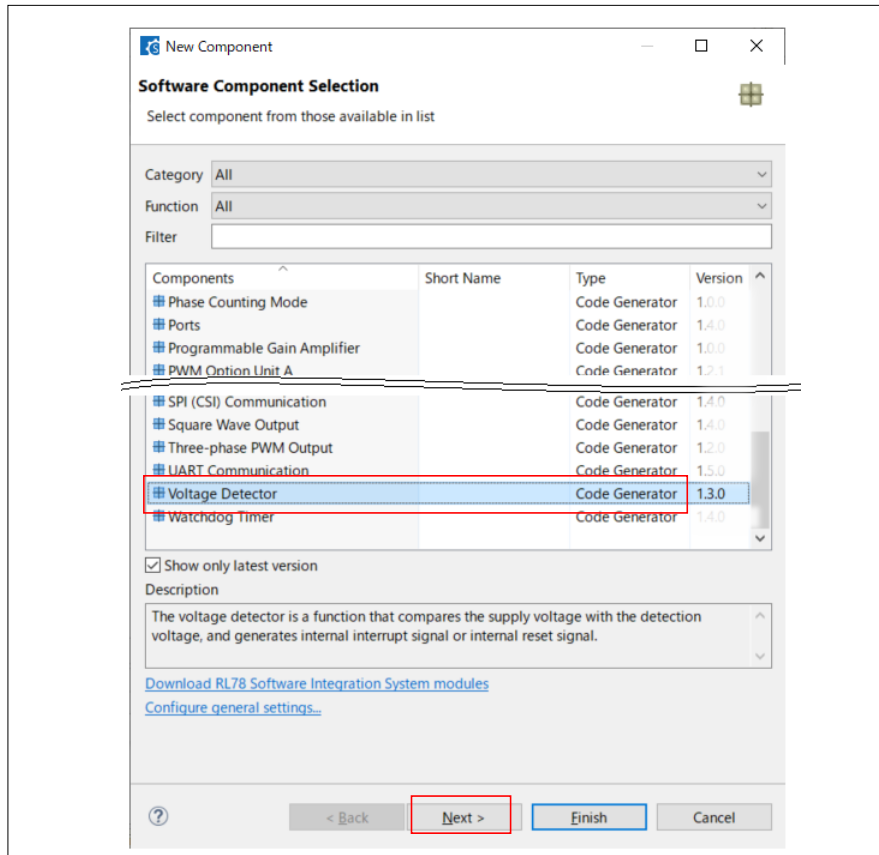

- Select the [LVD0] at the [Resource]. Check the configuration name and click the [Finish]. (The configuration name can be changed to any name.)

Figure 2-15 Select resource and check configuration name [Voltage Detector]

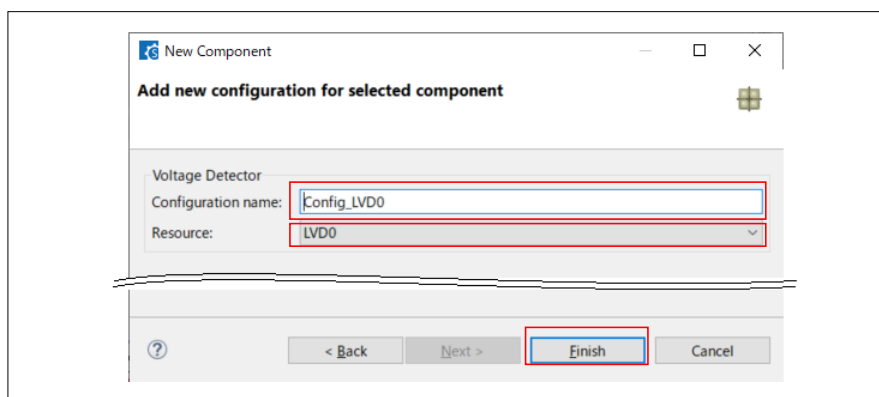

- The Voltage Detector is added to the component tree. In the settings screen, set the Voltage Detector according to your system.

Figure 2-16 Smart Configurator: [Voltage Detector] setting screen

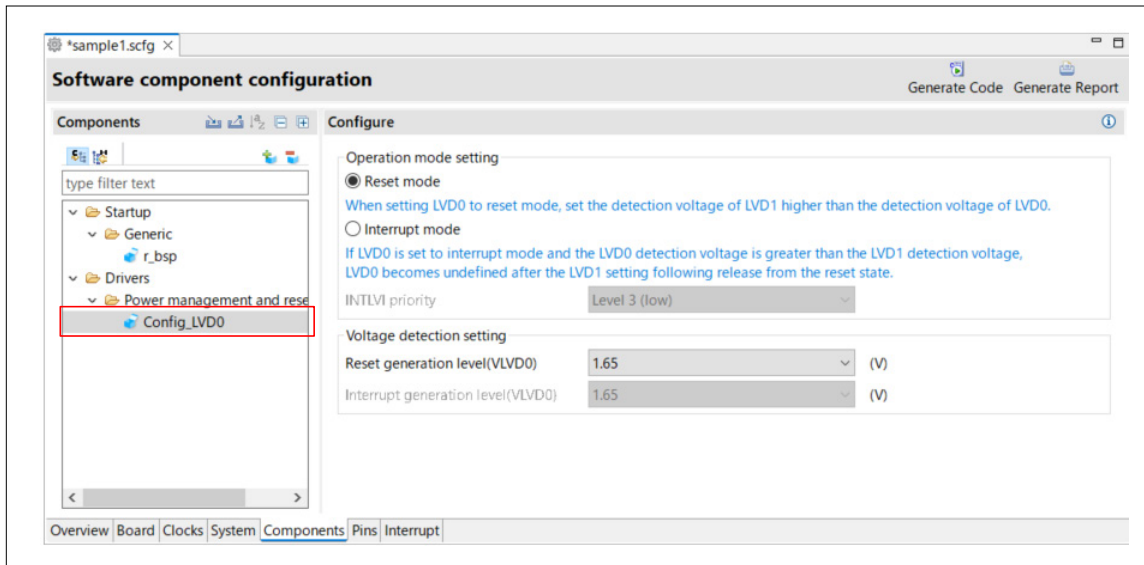

- Open the [New Component] dialog again, select the [Flexible Application Accelerator] and click the [Next].

Figure 2-17 Select [Flexible Application Accelerator]

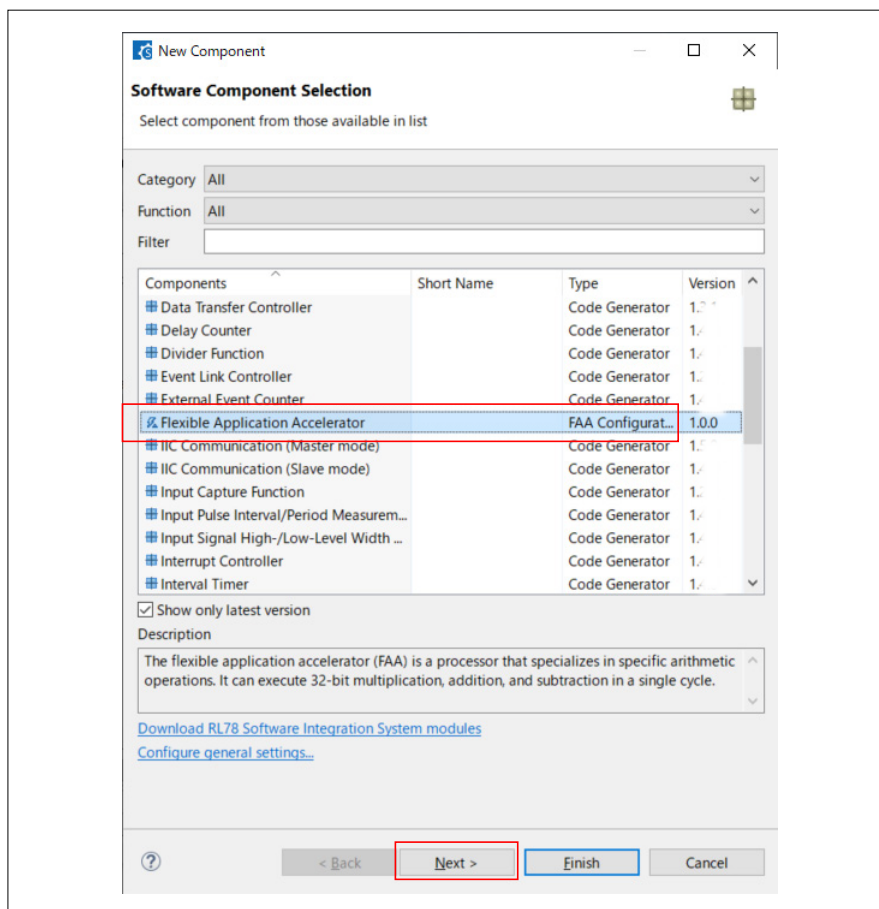

9. Check the configuration name and click the [Finish]. (The configuration name can be changed to any name.)

Figure 2-18 Select resource and check configuration name [Flexible Application Accelerator]

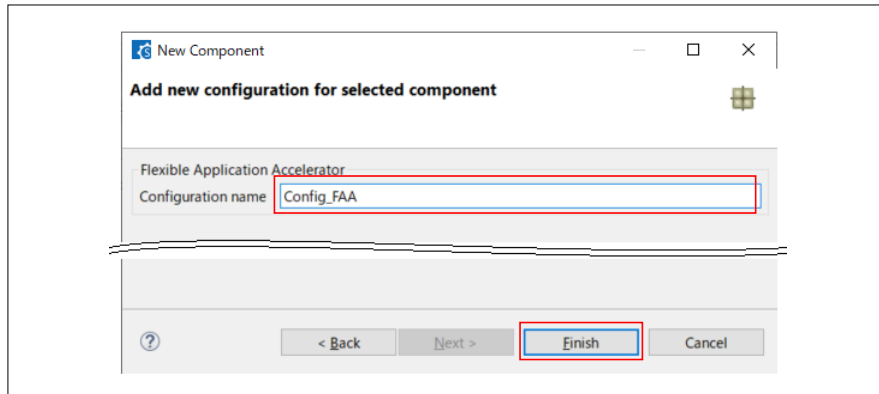

10. The Flexible Application Accelerator is added to the component tree.

Figure 2-19 Add [Flexible Application Accelerator] component

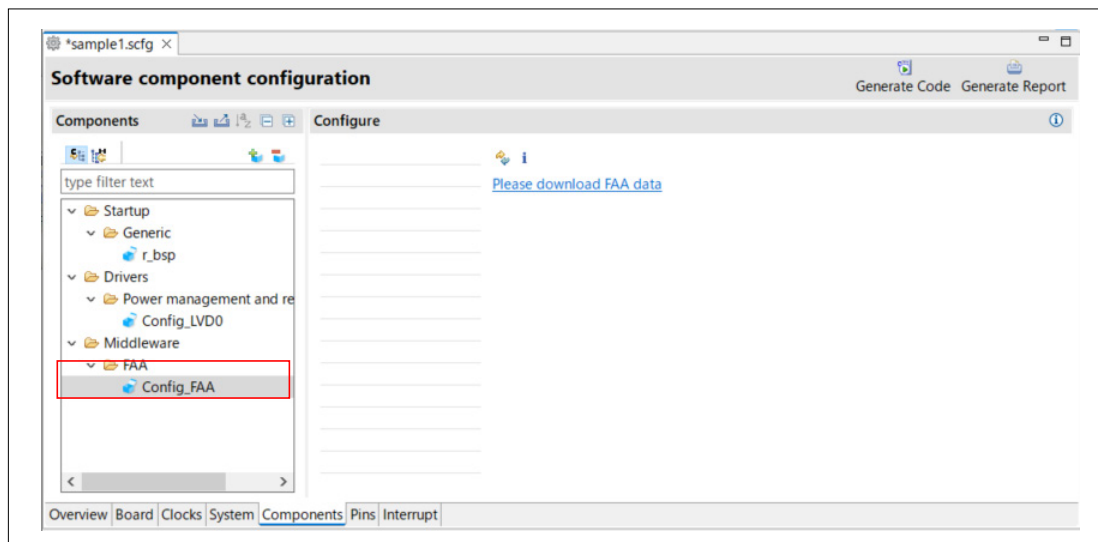

- When the FAA component is used for the first time, the download of FAA libraries or template from the configurator's dedicated server is needed. Click the [Update FAA modules] or the [Please download FAA data] to download them. (Please use the [Update FAA modules] to check and obtain the latest version libraries as well.)

Figure 2-20 Update/Download FAA module (Library)

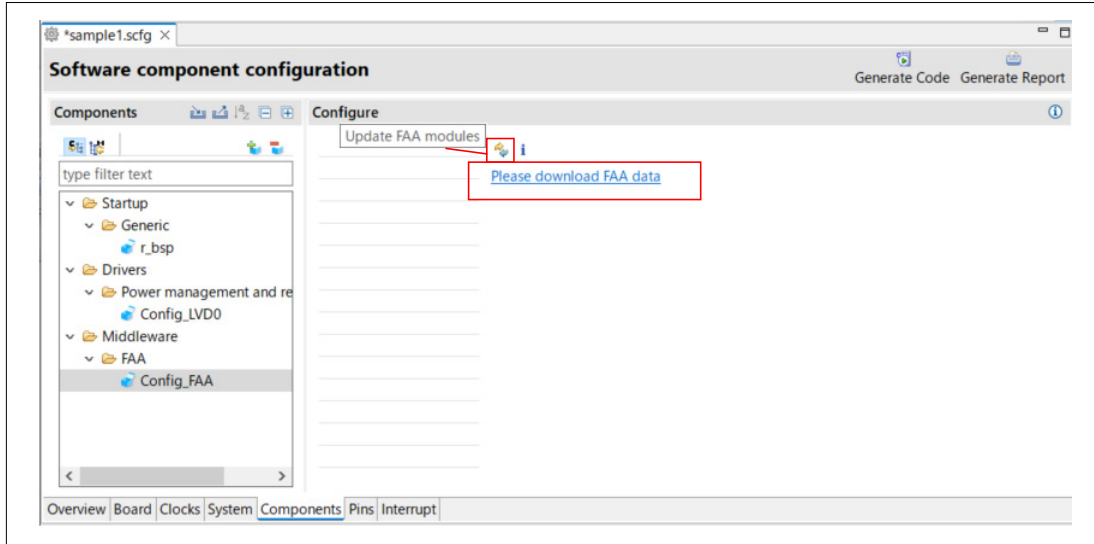

- Select the library you want to download and click the [Download]. In the disclaimer dialog that follows, click the [Agree].

Figure 2-21 Download FAA module (Library)

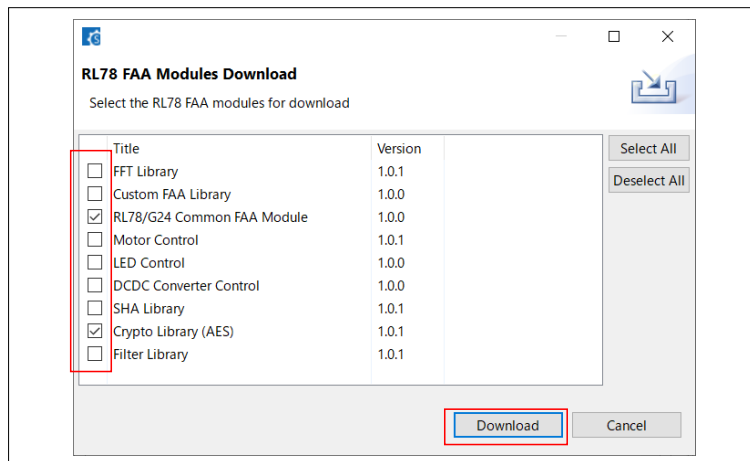

Remark. The content displayed on the actual download screen will differ.

Table 2-3 FAA library

Title	Overview
RL78/G24 Common FAA Library	The FAA program and data transfer routine described in 1.3.2 Transfer of Program and Data for FAA. When using FAA libraries/templates, this is always downloaded.
Custom Library	A template for writing FAA programs.
Others	FAA library of various function

13. The downloaded libraries are added. ("RL78/G24 Common FAA Module" is not displayed.)

Figure 2-22 Added FAA library

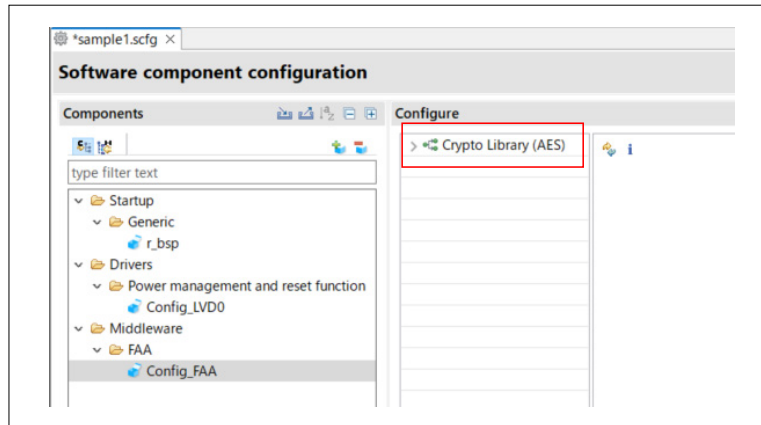

14. Check the box which libraries/functions you will actually use among the downloaded libraries. If there are any setting items in the properties of the checked function, set them as appropriate.

Figure 2-23 Select/set FAA library

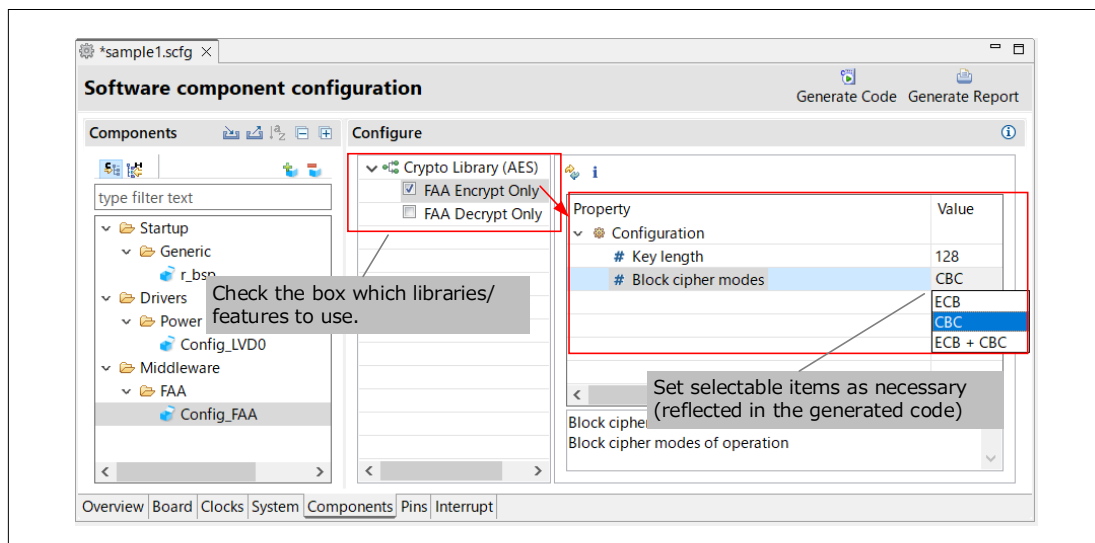

Remark. Two types of libraries and functions are provided: The subprocessor type, which can be used in conjunction with other functions, and the standalone type, which cannot. Do not use the standalone type simultaneously with any other library or function. When a standalone library or function is selected, selecting another library or function causes the following message to appear on the [Console] page.

Figure 2-24 Warning

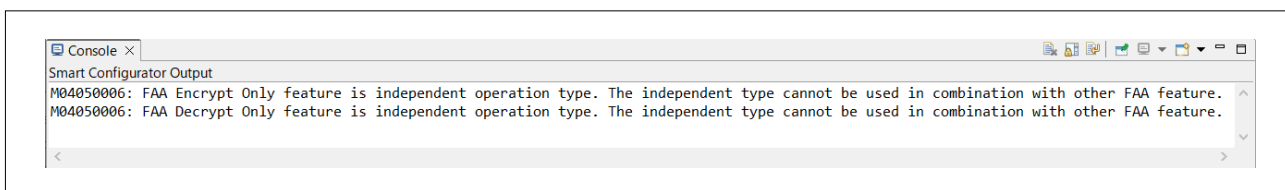

15. Click the [Generate Code] to generate source files of FAA library and added peripheral functions.

Figure 2-25 Generate Code

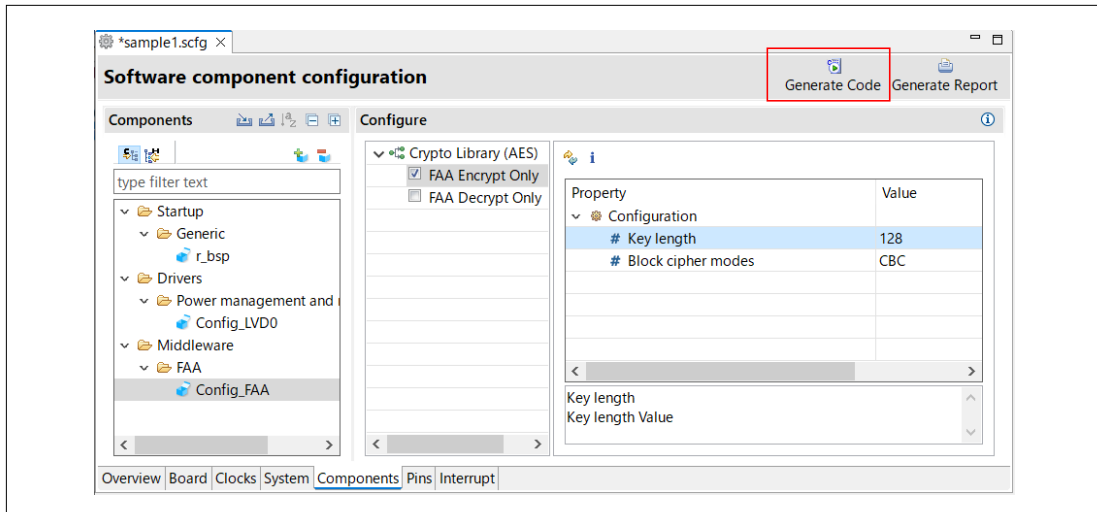

16. When the [Code Generating] dialog appears, click the [Continue].

Figure 2-26 [Code Generating] dialog

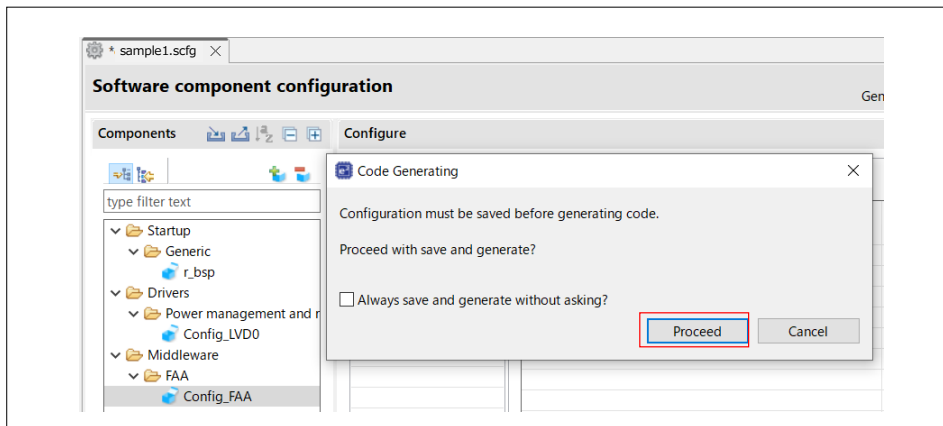

17. When the [Confirmation linker option change] dialog appears, click the [OK].

Figure 2-27 [Confirmation linker option change] dialog

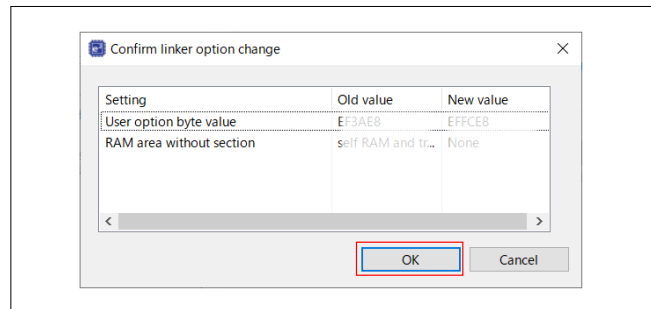

Remark. Some items set in Smart Configurator's the [Clock], the [System] and the [Voltage Detector] (LVD0) are reflected in option settings of the build tool (CC-RL).

18. Source files of the FAA library and added peripheral functions are generated and registered in the project. The files generated vary depending on the library you choose. The FAA library source files are shown below.

Figure 2-28 Registered FAA library source files

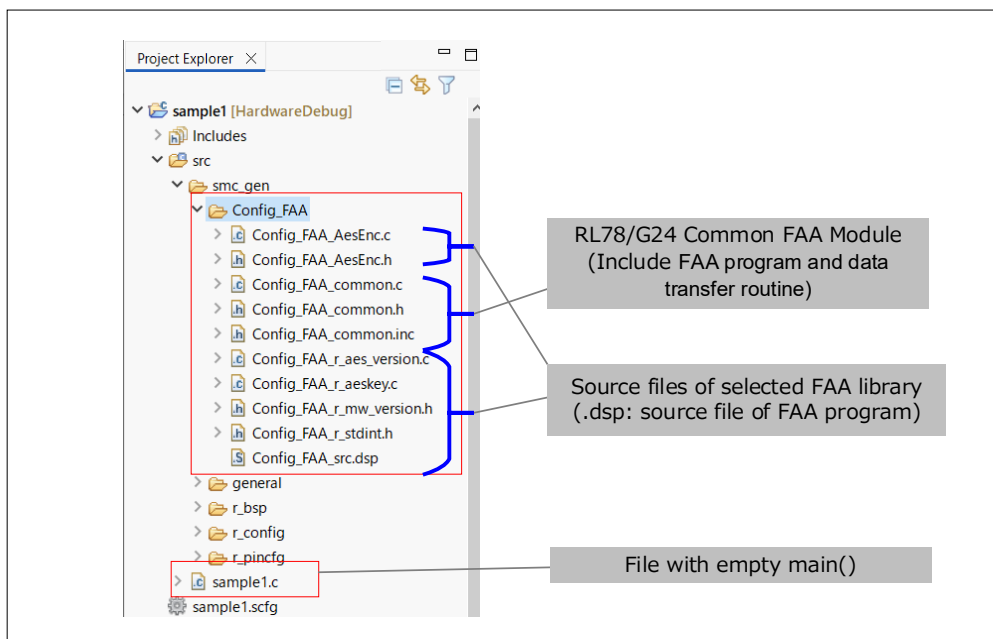

Remark 1. Some of the items set in “Clock”, “System” and “Voltage Detector (LVD0)” of the Smart Configurator (SC) are reflected in the Linker Option of Build Tool (CC-RL) .

Remark 2. For files other than the red frame above, refer to RL78 Smart Configurator User's Guide: e2 studio (R20AN0579).

19. API functions to control the FAA are defined in the FAA library source file. Call these functions in the CPU program to operate the FAA. Create a CPU program according to your system. For more information about API functions, see the documentation for each library. (<https://www.renesas.com/rl78g24> search for "documentation" on this page)

2.3.2 Overview of FAA library's File Structure

The overview of the FAA library file structure is shown below.

Table 2-4 Overview of FAA library's file structure

Library name	Files	Description
RL78/G24 Common FAA Library	<Config_FAA>_common.c <Config_FAA>_common.h	The transfer processing and common functions to control the FAA are defined. The transfer processing (R_Config_FAA_Create) is executed within the peripheral function initialization function (R_Systeminit) generated by SC, so there is no need to call it within the user program.
	<Config_FAA>_common.inc	SFRs for FAA are defined.
Custom FAA Library	<Config_FAA>_src.dsp	The template for the FAA source file.
Others	<Config_FAA>_XXX.c / asm / s <Config_FAA>_XXX.h /inc <Config_FAA>_src.dsp	FAA library of various functions. Refer to documents of each FAA library.

- <Config_FAA> is the configuration name set/checked in the step 9.
- "XXX" depends on each library.
- In the FAA source file (.dsp) provided by the FAA library and the template (Custom FAA Library), the code section name is defined as FAACODE and the data section name is defined as FAADATA.
- When using the DSPASM FAA/GREEN_DSP Structured Assembler version 1.50.0 or earlier and selecting the Custom FAA Library, add your user code and data to the template. If you build the template as is, an error will occur.

2.4 Build Tool Option Setting

Before starting a build, set the build tool options required to build the FAA program. Some options are set by the Smart Configurator (SC) in 2.3.1 Adding FAA Component. Manually set the options for which “No” is indicated in the “Set by SC” column in Table 2-5.

For build tool options that are not described in this guide, set them if necessary.

How to open the build tool property:

Select the project in the project tree, and then select the [Project] menu -> [Property] or select the [Property] from the context menu.

How to close the build tool property:

Select the [Apply and Close] to apply the changed option settings.

Figure 2-10 shows the build tool options required to build the FAA program.

Table 2-5 Setting options of build tool

Tool name	Category	Item	Description	Set by SC
FAA Assembler	Preprocessor control	How to identify the macro (-macro_exact)	exact	Yes
	Code generation	Section name (-dsp_section)	FAACODER,FAADATAR	Yes
		Section to map form ROM to RAM (-rom)	FAACODE=FAACODER,FAADATA=FAADATAR	Yes
Linker	Section	Layout sections automatically (-auto_section_layout)	Check or Uncheck	No
		Sections (-start)	FAACODE,FAADATA/XXXX XXXX (hexadecimal number without “0x”) specifies an even address after address D8H in the code flash memory.	No
		Allocate FAA memory area automatically (-dsp_memory_area)	Yes or Yes(Automatically allocate sections by striding FAA memory area) ^{Note2}	Yes ^{Note1}
	Output	ROM to RAM mapped section (-rom)	FAACODE=FAACODER FAADATA=FAADATAR	Yes

Note 1. SC sets “Yes”.

2. When the RAM size used by the user program (CPU program) is larger than 2304 bytes (the user RAM area before the FAA code area on RAM), manually set it to “No”. Also, when “Yes(Automatically allocate sections by striding FAA memory area)” is specified, check the checkbox of “Layout sections automatically”.

2.4.1 FAA Assembler Options

Figure 2-29 FAA Assembler - Preprocessor control

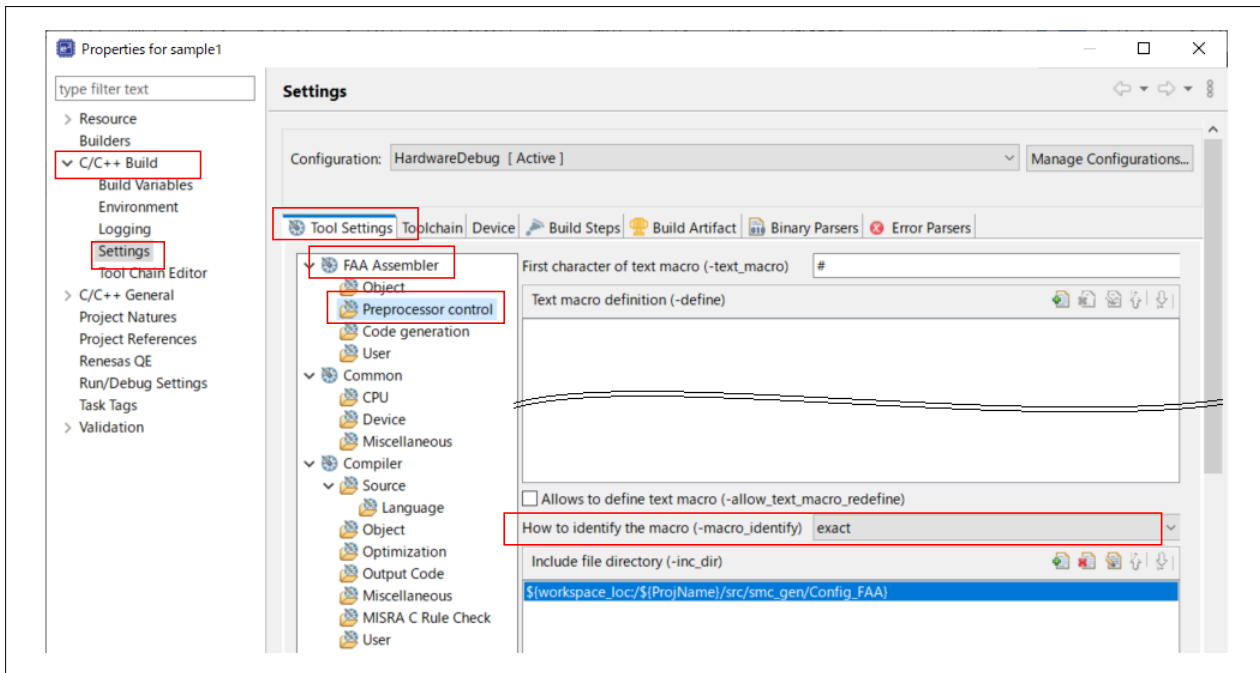

Table 2-6 FAA Assembler - Preprocessor control, Overview of settings

Category	Item	Description
Preprocessor control	How to identify the maro (-macro_exact)	Set "exact". A text macro is replaced in the FAA source file in units of tokens. Unless Exact is specified, replacement is performed even if the identifier to be replaced is included in another identifier.

Figure 2-30 FAA Assembler - Code Generation

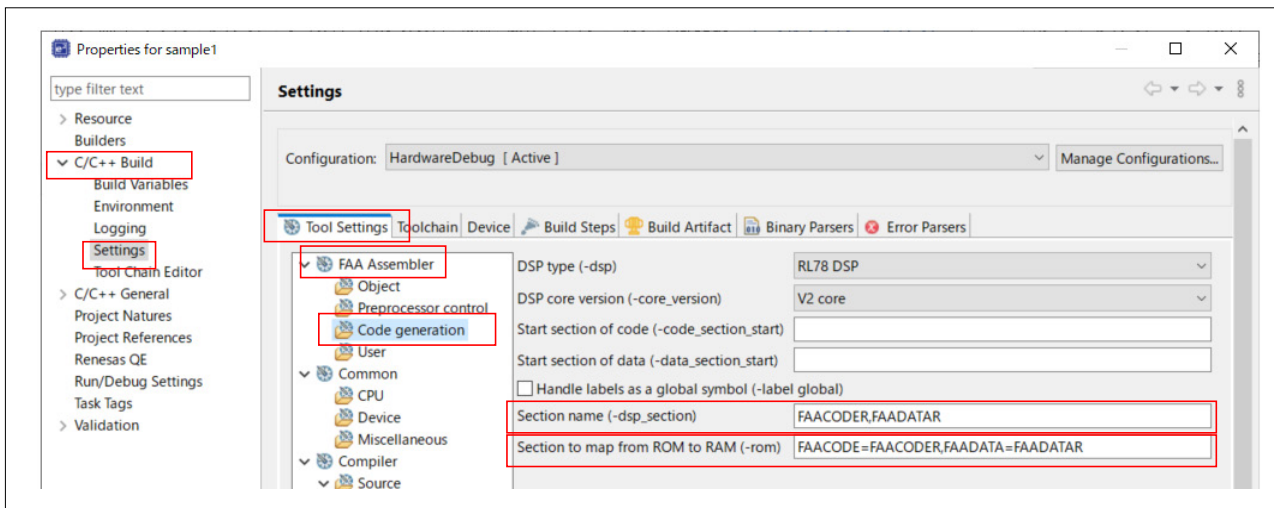

Table 2-7 FAA Assembler - Code Generation, Overview of settings

Category	Item	Description
Code Generation	Section name (-dsp_section)	<p>Set "FAACODER,FAADATAR".</p> <p>In the FAA program file (library or template) generated by the Smart Configurator (SC), the code section name is defined in FAACODE and the data section name is defined in FAADATA.</p> <p>However, specify the section name FAACODER and FAADATAR to be relocated to the RAM area.</p>
	Section to map from ROM to RAM (-rom)	<p>Set "FAACODE=FAACODER,FAADATA=FAADATAR".</p> <p>The definition symbols for the FAA program and data placed in the code flash memory will be relocated to the internal RAM (instruction code memory and data memory). If relocation is not performed, the addresses of the FAA program and data symbols will remain in the code flash memory area, and symbol information cannot be handled correctly during debugging.</p> <p>The left side specifies the FAA program and data sections located in code flash memory. The right side specifies the section of RAM to be transferred.</p> <p>In the processing to transfer the FAA program and data to the instruction code memory and data memory (in Config_FAA_Common.c generated by SC), FAACODER and FAADATAR is handled as the transfer destination RAM section, so the right side specifies FAACODER and FAADATAR.</p>

2.4.2 Linker Options

Figure 2-31 Linker - Sections

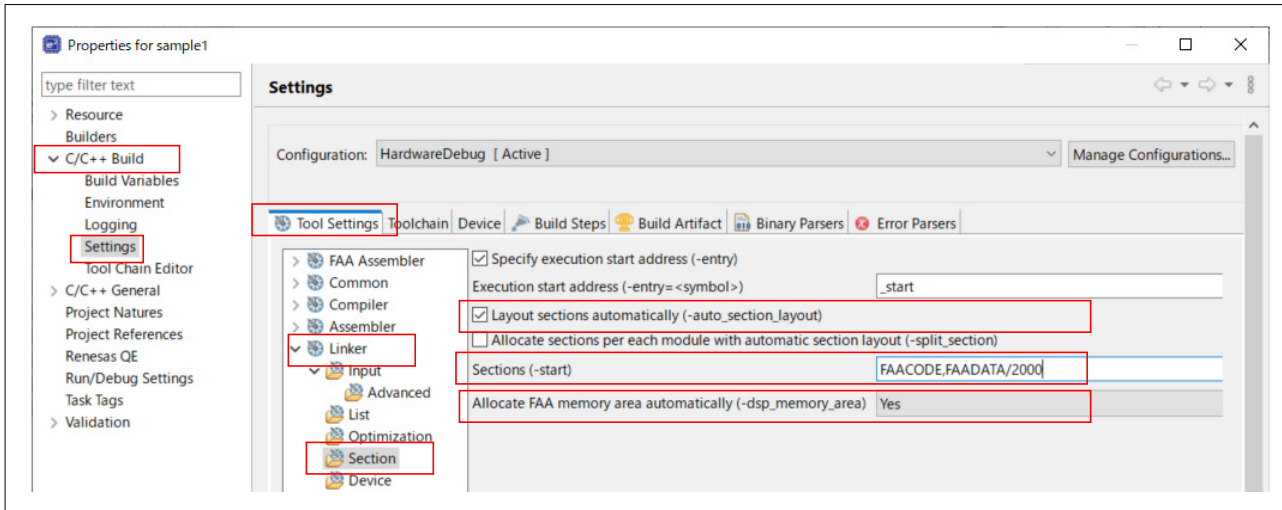

Table 2-8 Linker - Section, Overview of settings

Category	Item	Description
Section	Layout sections automatically (-auto_section_layout)	Check the box. Sections are automatically allocated based on information in the device file. When unchecking, the address of each section used in the program need to be specified in "Section Start Address".
	Sections (-start)	Set "FAACODE,FAADATA/address". Specify the address of code flash memory to store FAA programs and data. In the FAA program file (library or template) generated by the Smart Configurator (SC), the code section name is defined in FAACODE and the data section name is defined in FAADATA. Therefore, specify "FAACODE" and "FAADATA" as the section name. In addition, SC provides the processing (in Config_FAA_Common.c, generated by SC) to transfer the FAA program and data to the instruction code memory and data memory. The processing is performed in units of 2 bytes. Therefore, FAACODE and FAADATA must be aligned to the 2-byte boundary. specify an even number address after D8H. (at address 2000H in the example).
	Allocate FAA memory area automatically (-dsp_memory_area)	Set "Yes". Reserve a dedicated area for FAA in the internal RAM. Variables for the CPU program will not be placed in the FAA instruction code memory (FD800H-FE7FFH) or data memory (FE800H-FEFFFH) in the internal RAM.

Figure 2-32 Linker - Output

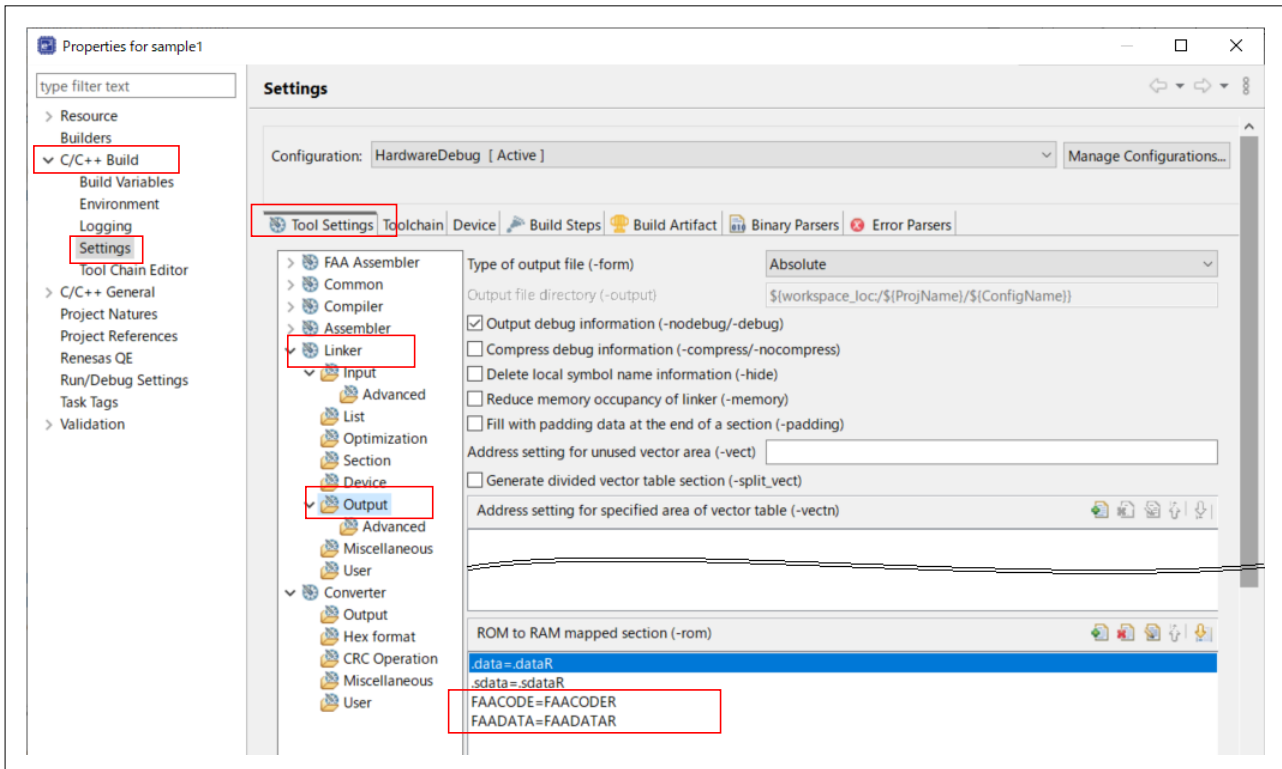
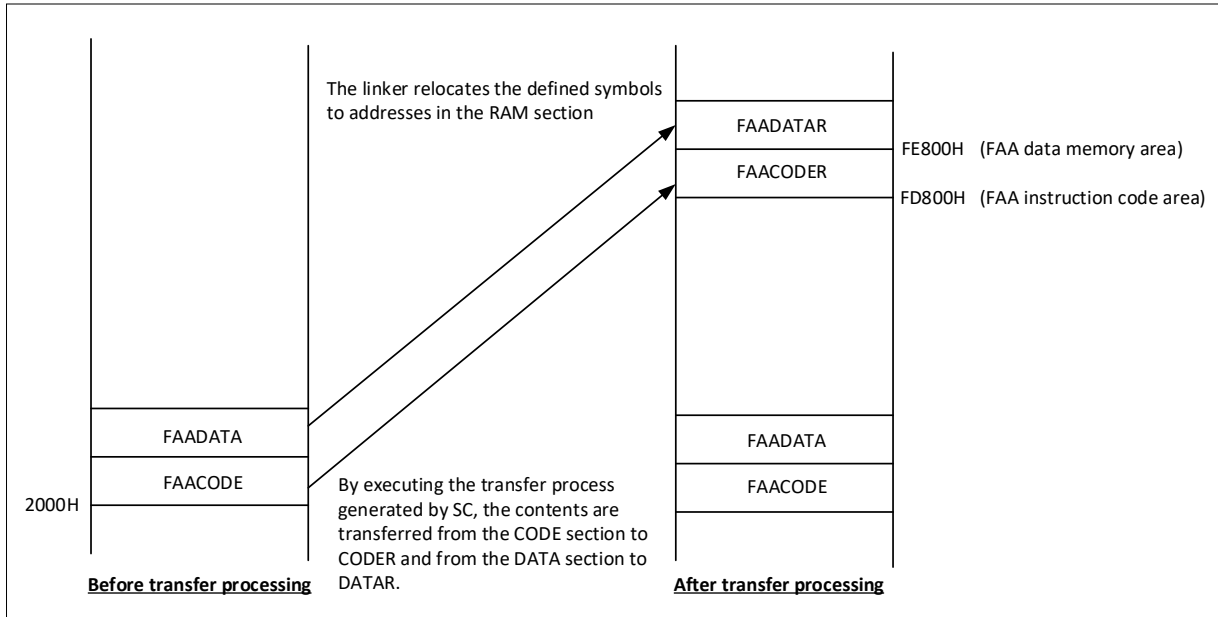

Table 2-9 Linker - Output, Overview of settings

Category	Item	Description
Output	ROM to RAM mapped section (-rom)	<p>Set "FAACODE=FAACODER,FAADATA=FAADATAR".</p> <p>The definition symbols for the FAA program and data placed in the code flash memory will be relocated to the internal RAM (instruction code memory and data memory). If relocation is not performed, the addresses of the FAA program and data symbols will remain in the code flash memory area, and symbol information cannot be handled correctly during debugging.</p> <p>The left side specifies the FAA program and data sections located in code flash memory. The right side specifies the section of RAM to be transferred.</p> <p>In the processing to transfer the FAA program and data to the instruction code memory and data memory (in Config_FAA_Common.c generated by SC), FAACODER and FAADATAR is handled as the transfer destination RAM section, so the right side specifies FAACODER and FAADATAR.</p>

Figure 2-33 Memory image before and after transfer processing



2.4.3 Program Building

After setting the build tool options necessary to build the FAA program, build it. There are several ways to run a build. Two methods are described here.

- Select the [Project] menu -> [Build Project] (Figure 2-34)
- Click the [Builds the project] on the toolbar (Figure 2-35)

Figure 2-34 [Project] menu

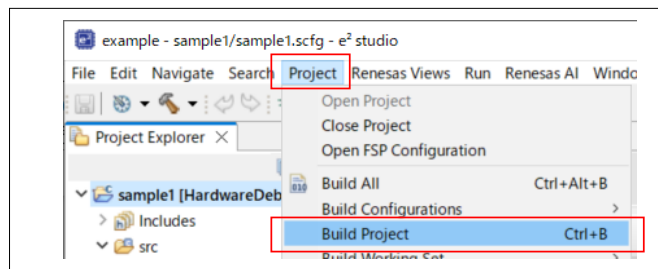
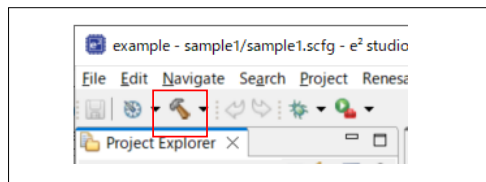
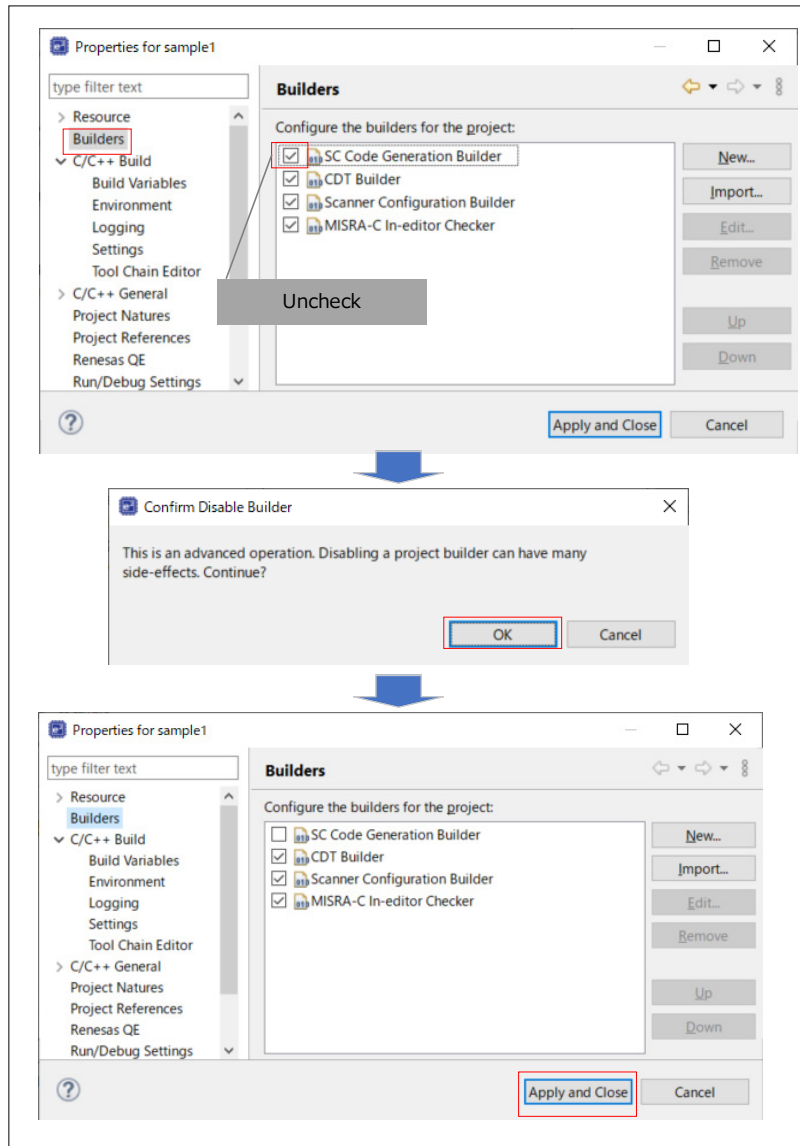

Figure 2-35 Tool bar



Remark. Smart Configurator (SC) automatically generates code before building or after cleaning the project to prevent mismatches between the settings on SC's GUI and the generated code in the file. To stop this function, uncheck "SC Code Generation Builder" in the project properties.

Figure 2-36 SC Code Generation Builder



2.5 Debug Tool Option Setting

Before downloading an executable object to the RL78/G24 Fast Prototyping Board, set the debug tool options required to debug an FAA program. Some options are set by the Smart Configurator (SC) in 2.3.1 Adding FAA Component. Manually set the options for which “No” is indicated in the “Set by SC” column in Table 2-10. For debug tool options that are not described in this guide, set them if necessary.

After setting the required options, download the object.

How to open the debug configurations:

1. Select the project on the project tree, and then select the [Run] -> [Debug Configurations] or select the [Debug as] -> [Debug Configurations].
2. In the [Debug Configurations] dialog, click the [“Project name” Hardware Debugging] under the [Renesas GDB Hardware Debugging].

How to close the build tool property:

Select the [Apply] and [Close] to apply the changed option settings.

Figure 2-37 Debug Configurations

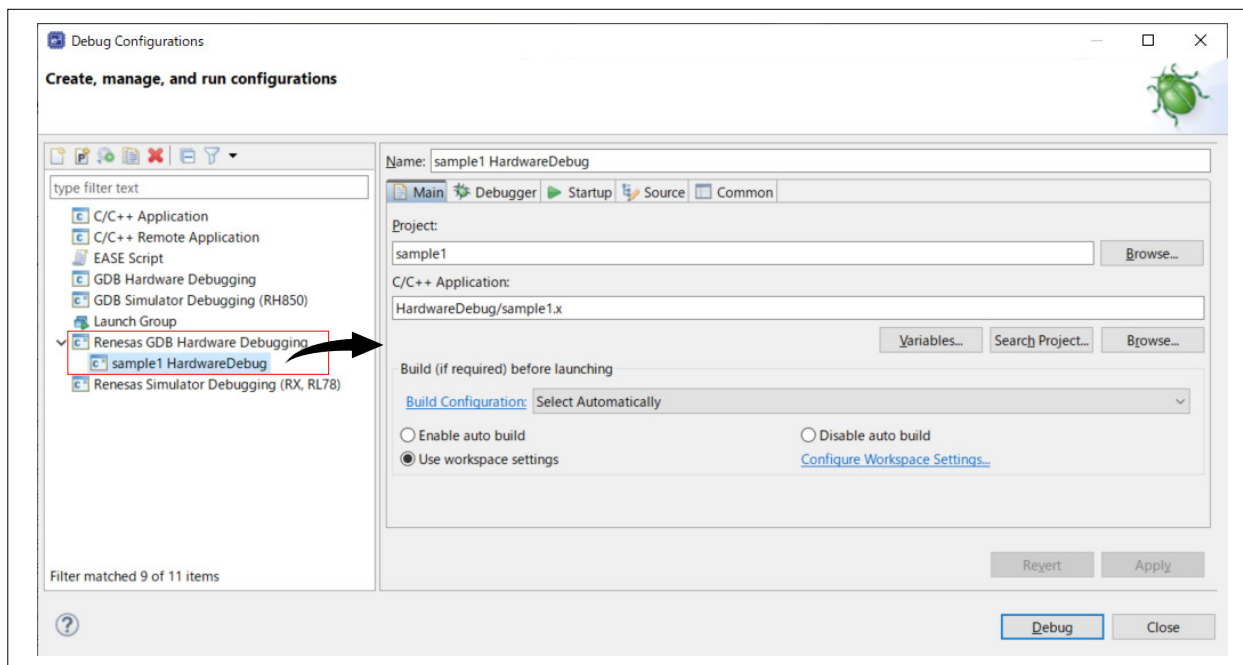

Table 2-10 shows the build tool options required to build the FAA program.

Table 2-10 Setting options of debug tool

Tab	Lower tab	Item	Description	Set by SC
Debugger	Multiple Core Setting	Core State – FAA	Enabled	Yes ^{Note1}
Startup	-	Load image and symbols	Filename: “Project name”GreenDSP_Core.x Load type: Symbols only Offset (hex): 0 On connect: Yes Core: FAA	No

Note1. Only when the debugger selected in e2 studio’s debug configuration matches the debugger selected in SC’s System settings

2.5.1 Debugger Options

Figure 2-38 Debugger options

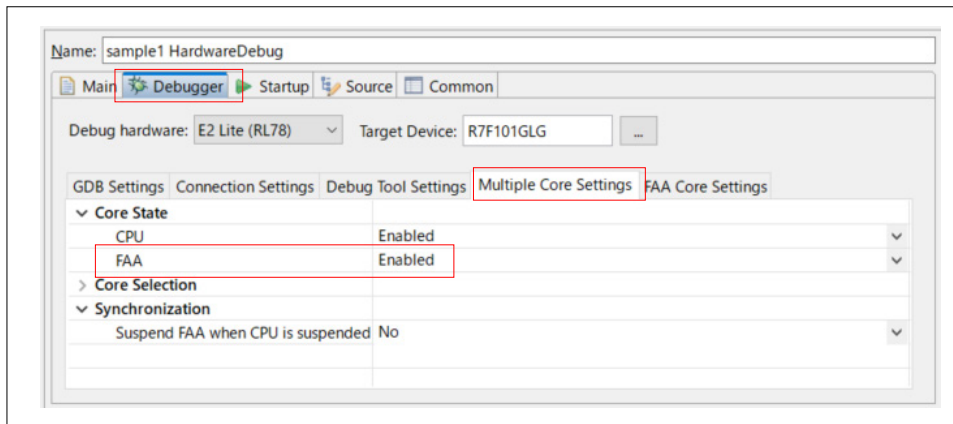

Table 2-11 Setting options of debug tool, Overview of settings

Lower tab	Item	Description
Multiple Core Settings	Core State - FAA	Set "Enabled". Enable source debugging of the FAA program.

2.5.2 Startup Options

Figure 2-39 Startup options

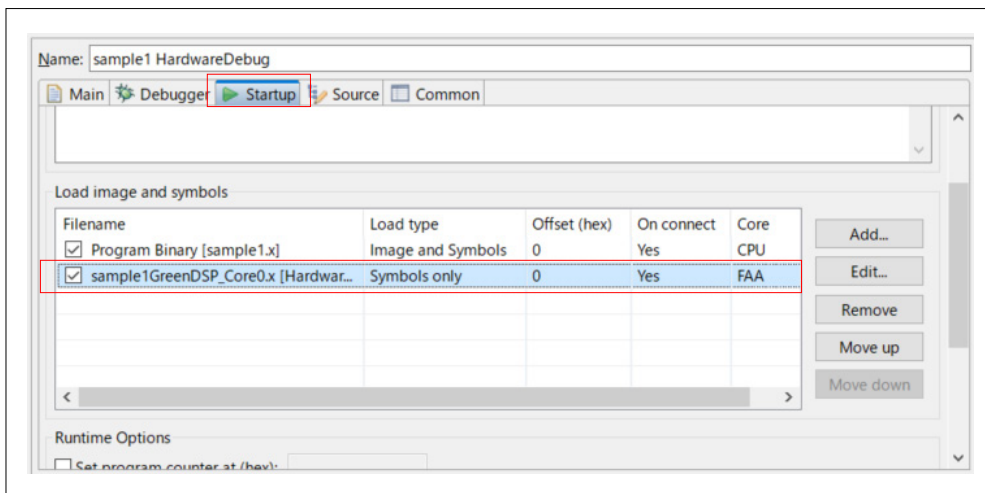

Table 2-12 Startup options, Overview of settings

Lower tab	Item	Description
-	Load image and symbols	Specify the binary module of the FAA program. Filename: "Project name"GreenDSP_Core.x Load type: Symbols only Offset (hex): 0 On connect: Yes Core: FAA The symbols of the FAA program's binary module are downloaded to enable source debugging of the FAA program.

How to set:
 (Do this after the project has finished building.)

1. Click the [Add].

Figure 2-40 Adding module (1/6)

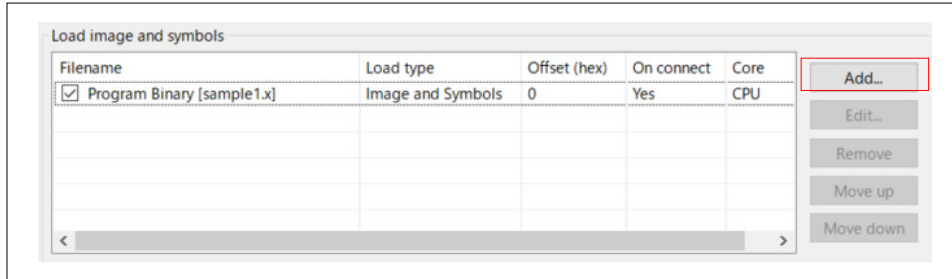

2. Click the [Search Project] in the [Add download module] dialog.

Figure 2-41 Adding module (2/6)

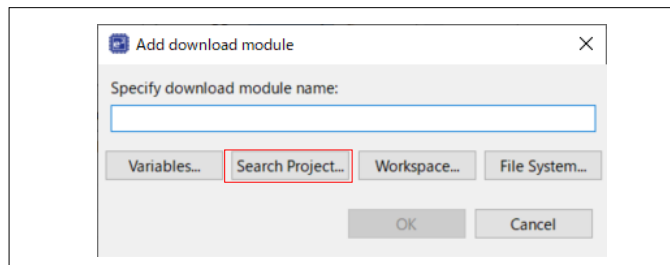

3. Click the “Project name”GreenDSP_Core0.x” and click the [OK].

Figure 2-42 Adding module (3/6)

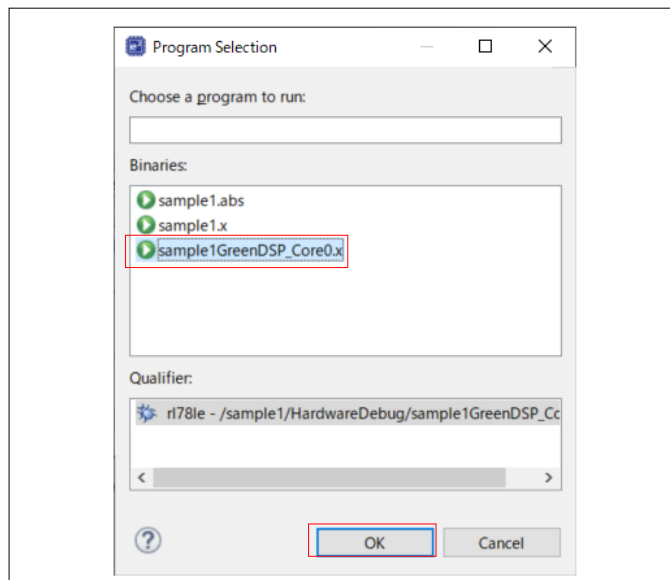

4. Click the [OK].

Figure 2-43 Adding module (4/6)

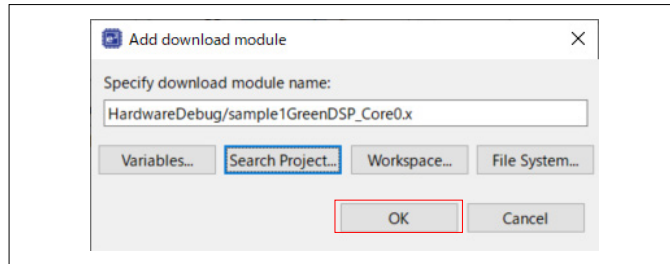

5. Set "Symbols only" in the [Load type and "FAA" in the [Core].

Figure 2-44 Adding module (5/6)

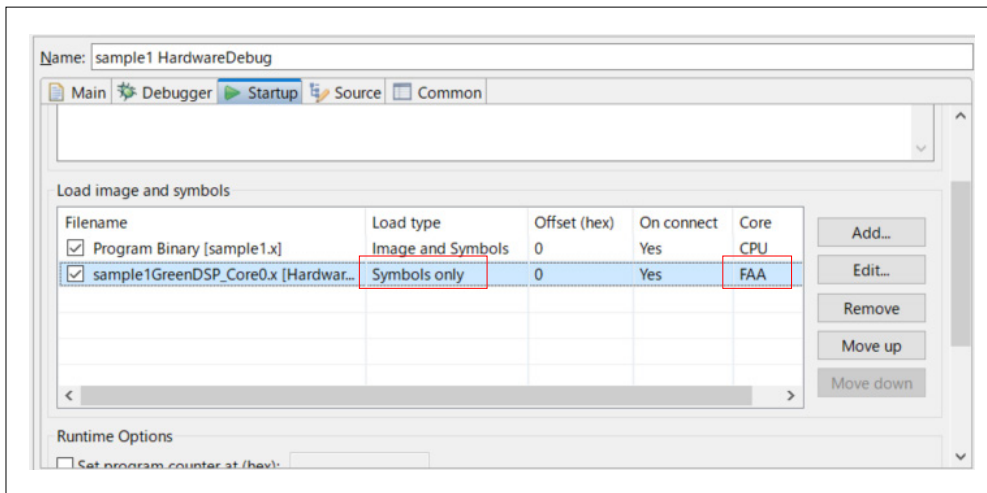

6. Click the [Apply] and the [Close].

Figure 2-45 Adding module (6/6)

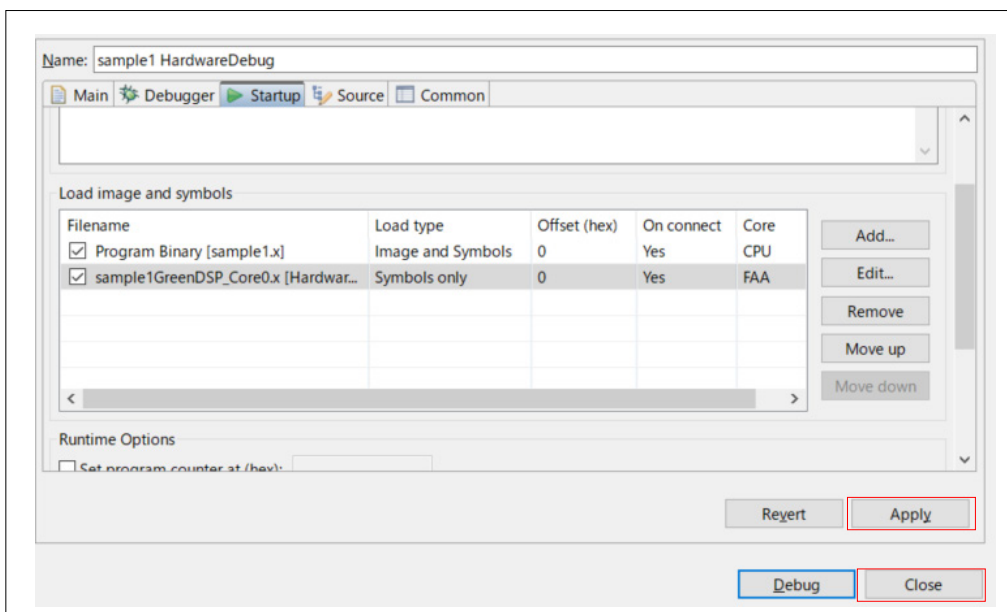

2.5.3 Program Download

After setting the debug tool options necessary to debug the FAA program, connect PC and RL78/G24 Fast Prototyping Board and then download the object. There are several ways to download. Two methods are described here.

- Select the [Run] menu -> [Debug] (Figure 2-46)
- Click the button on the toolbar (Figure 2-47)

Caution1: Before downloading, check the power supply in the [Debug Configurations] dialog.

- [Debugger] tab -> [Connection Settings] tab -> [Connection with Target Board]

Caution2: The FAA program is not placed in the instruction code memory by simply downloading the object. You need to transfer the FAA program and data from the code flash memory to the instruction code memory and data memory by using the CPU program.

The RL78 Smart Configurator provides transfer processing function (R_Config_FAA_Create) as FAA components. The transfer processing function is executed in the initialization routine (R_Systeminit) before the main function is executed, and the transfer is performed.

Figure 2-46 [Debug] menu

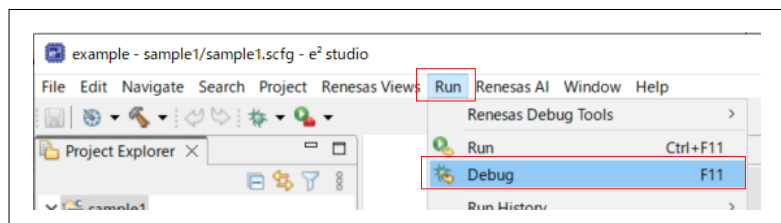
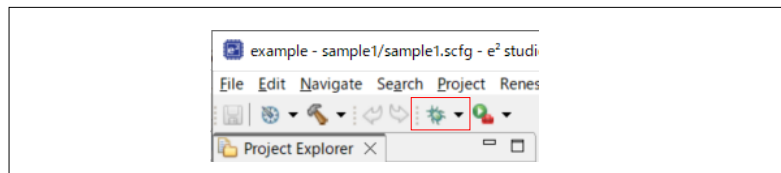

Figure 2-47 Debug tool bar



2.6 FAA Program Debug

2.6.1 Debug Target

When debugging the RL78/G24 program, select whether to debug the CPU or FAA. The debug target is selected in the [Debug] view.

- How to select CPU: Select the source under the “(CPU) [core: 0]. (Figure 2-48)
- How to select FAA: Select the source under the “(FAA) [core: 1]. (Figure 2-49)

Figure 2-48 Selecting CPU as debug target

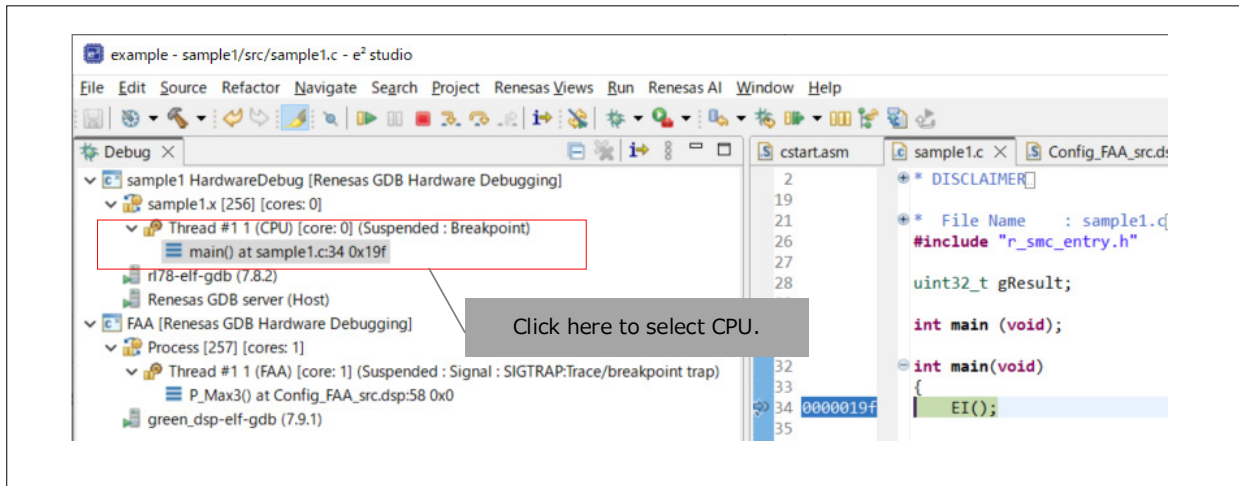
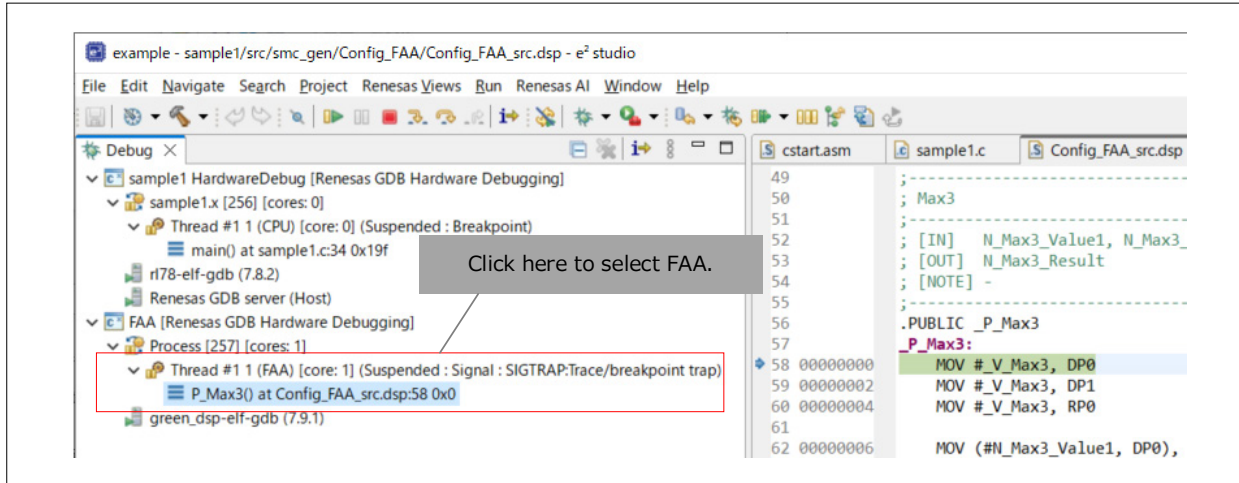

Figure 2-49 Selecting FAA as debug target



Address information is displayed in the address area only for the source file to be debugged, and debugging operations such as step execution are possible at the source level.

It is possible to change the debug target while the program is running.

2.6.2 Source File Display

After selecting the FAA as the debug target, display the .dsp file containing the FAA program on the [Editor] panel. The address information appears in the address area, and debug operations such as step execution can be performed at the FAA source level.

The address area indicates the addresses in the FAA instruction code memory space. The address area is not displayed when the debug target is CPU.

Figure 2-50 Source file display

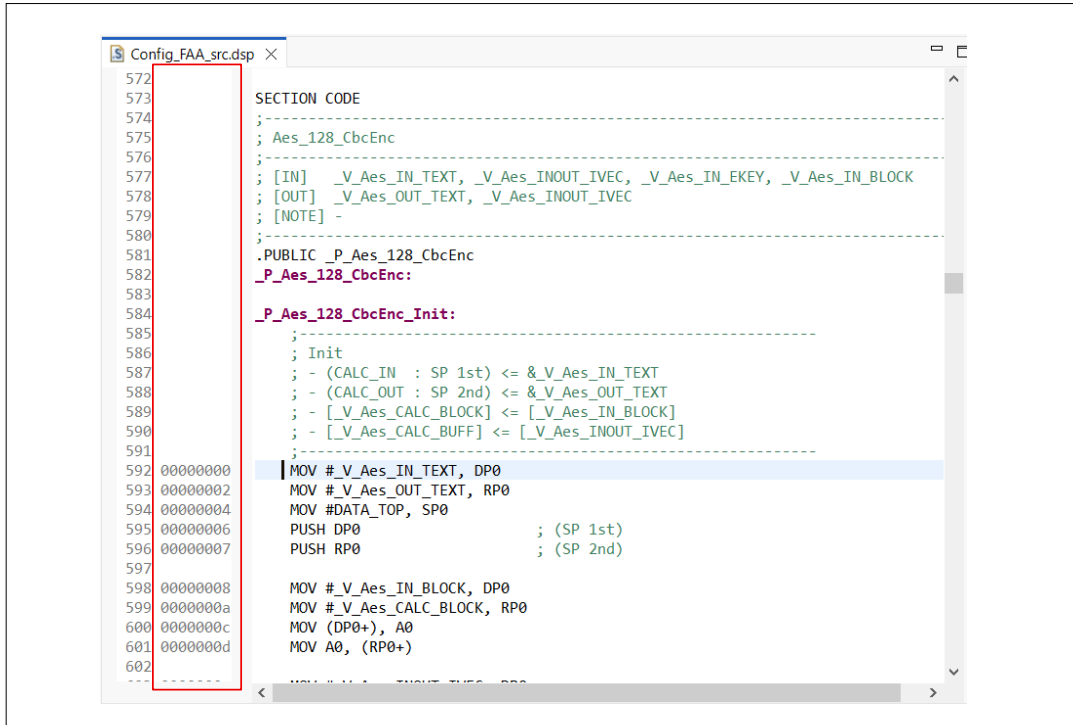

2.6.3 Run / Stop

When selecting FAA as the debug target, FAA source debugging is enabled. There are several ways to run/stop FAA program. Two methods are described here.

- Select the [Run] menu -> [Resume] / [Suspend]. (Figure 2-51)
- Click the [Resume] / [Suspend] on the toolbar. (Figure 2-52)

Figure 2-51 [Run] menu

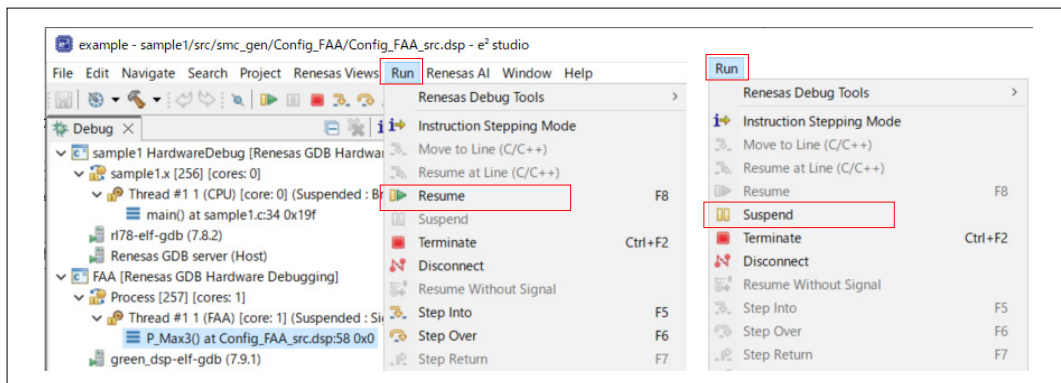
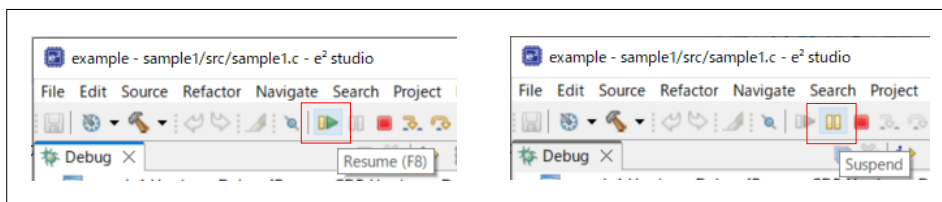

Figure 2-52 Debug tool bar



The FAA program control are as follows:

- ✓ If the FAA status is the following cases, program execution cannot start and other debug operations such as step execution are also disabled.
 - Clock is not supplied to the FAA. (FAAEN bit = 0)
 - The FAA operation is disabled. (ENB bit = 0)

In the CPU program, set the FAA to an enable state (FAAEN = 1, ENB = 1).
- ✓ When the debug target is FAA, the operation to execute or stop programs only executes or stops the FAA program. The CPU program is not executed or stopped in synchronization. However, you can use a debug tool option so that stopping a CPU program also stops the FAA program when the debug target is CPU. To do this, on the [Debugger] tab -> the [Multiple Core Settings] tab -> the [Synchronization] category, select [Yes] for [Suspend FAA when CPU is suspended].
- ✓ Step execution is applicable only to the FAA.
- ✓ Reset operation performs a software reset for the FAA. The whole MCU (CPU and peripheral functions) are not reset. When the debug target is CPU, the whole MCU (CPU and peripheral functions) are reset.
- ✓ Do not proceed with debugging of the FAA during execution of a CPU program that includes operations with the WIND register. Since the debugger temporarily rewrites the WIND register in the debugging operations for the FAA, the use of FAA debugging may make operation of the program being executed by the CPU incorrect.

- ✓ If you change the source file of the CPU or FAA program and build it while debugging, the modified program will not be downloaded correctly even if you download it. If you make changes to your program, disconnect, and reconnect the debug connection.
- ✓ The [Resume All] and [Pause All] buttons on the toolbar do not work in projects that debug CPU and FAA.
- ✓ If the FAA is started or stopped by the CPU program, the state of the FAA on the [Debug] view is not updated. Even if you select FAA in the [Debug] view, FAA information (status, [Register] view, etc.) will not be updated. Click the [Refresh All] button on the toolbar to refresh each view.

Figure 2-53 Debug tool bar - Resume all, Suspend all, Refresh all

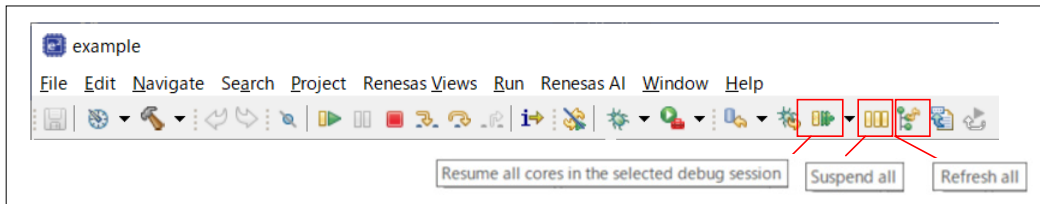

- ✓ One way to end debugging is to click the [Terminate all] button, which will close both the CPU and the FAA debug sessions.

Figure 2-54 Debug tool bar - Terminate all

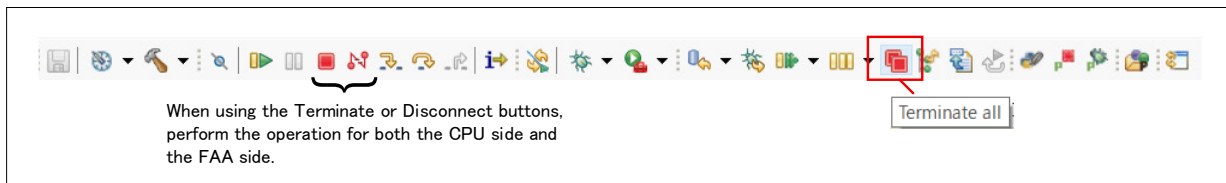

2.6.4 Breakpoint

After selecting the FAA as the debug target, display the FAA source on the editor. You can set a breakpoint by double-clicking outside the source row on which you want to set the breakpoint. To cancel a breakpoint, double-click the icon set for the breakpoint.

The breakpoint controls for the FAA program are as follows:

- ✓ 4 points hardware breaks are available. (Break after execution)
- ✓ If the FAA is stopped after detecting a hardware break, the CPU is not synchronously stopped.

Note. Do not set software breakpoints in the area (code flash memory) that contains the FAA program and data before they are transferred to the FAA area.

If you have set breakpoints in this area, make sure to remove them before transferring the FAA code and data.

Figure 2-55 FAA program, breakpoint setting

```

Config_FAA_src.dsp
48 SECTION CODE
49 ;-----
50 ; Max3
51 ;-----
52 ; [IN] N_Max3_Value1, N_Max3_Value2, N_Max3_Value3
53 ; [OUT] N_Max3_Result
54 ; [NOTE] -
55 ;-----
56 .PUBLIC _P_Max3
57 _P_Max3:
58 MOV #_V_Max3, DP0
59 MOV #_V_Max3, DP1
60 MOV #_V_Max3, RP0
61
62 MOV (#N_Max3_Value1, DP0), A0
63 MOV (#N_Max3_Value2, DP1), R0
64 JSR #P_Max2_Direct ; A0 = Max2(Value1, Value2)
65
66 MOV (#N_Max3_Value3, DP1), R0
67 JSR #P_Max2_Direct ; A0 = Max2(A0, Value3)
68
69 MOV A0, (#N_Max3_Result, RP0)
70

```

2.6.5 Memory

When selecting FAA as the debug target, FAA instruction code memory and data memory are displayed in the [Memory] view.

The memory display control for the FAA are as follows:

- ✓ To display the FAA area, specify the display address as follows. (Figure 2-56, Figure 2-57)
 - FAA instruction code memory area:
Address of FAA instruction code memory area + 0x10000000
 - FAA data memory area:
Address of FAA data memory area + 0
- ✓ When the debug target is CPU, CPU memory is displayed in the [Memory] view.
- ✓ The display cannot be updated while the FAA program is running.
- ✓ If the FAA status is the following cases, the display contents are undefined.
 - Clock is not supplied to the FAA. (FAAEN bit = 0)
 - The FAA operation is disabled. (ENB bit = 0)

Figure 2-56 [Memory] view, FAA instruction code memory area

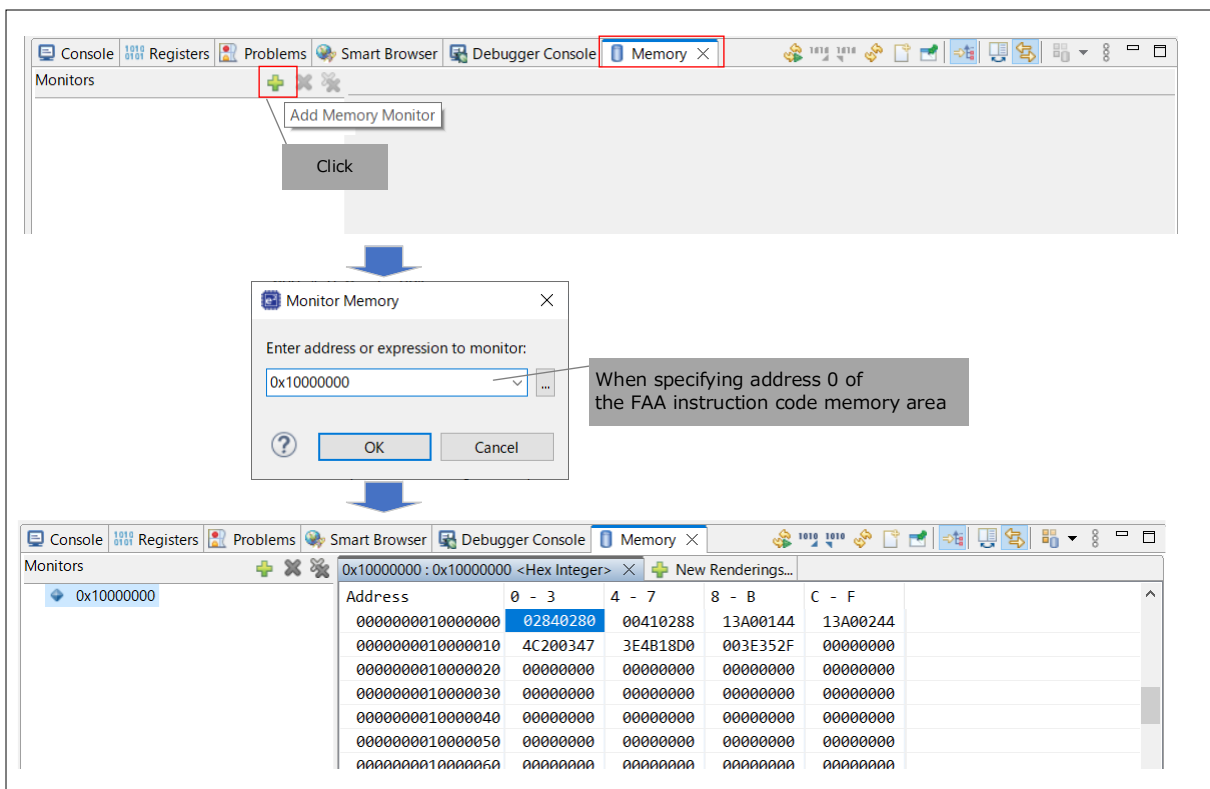
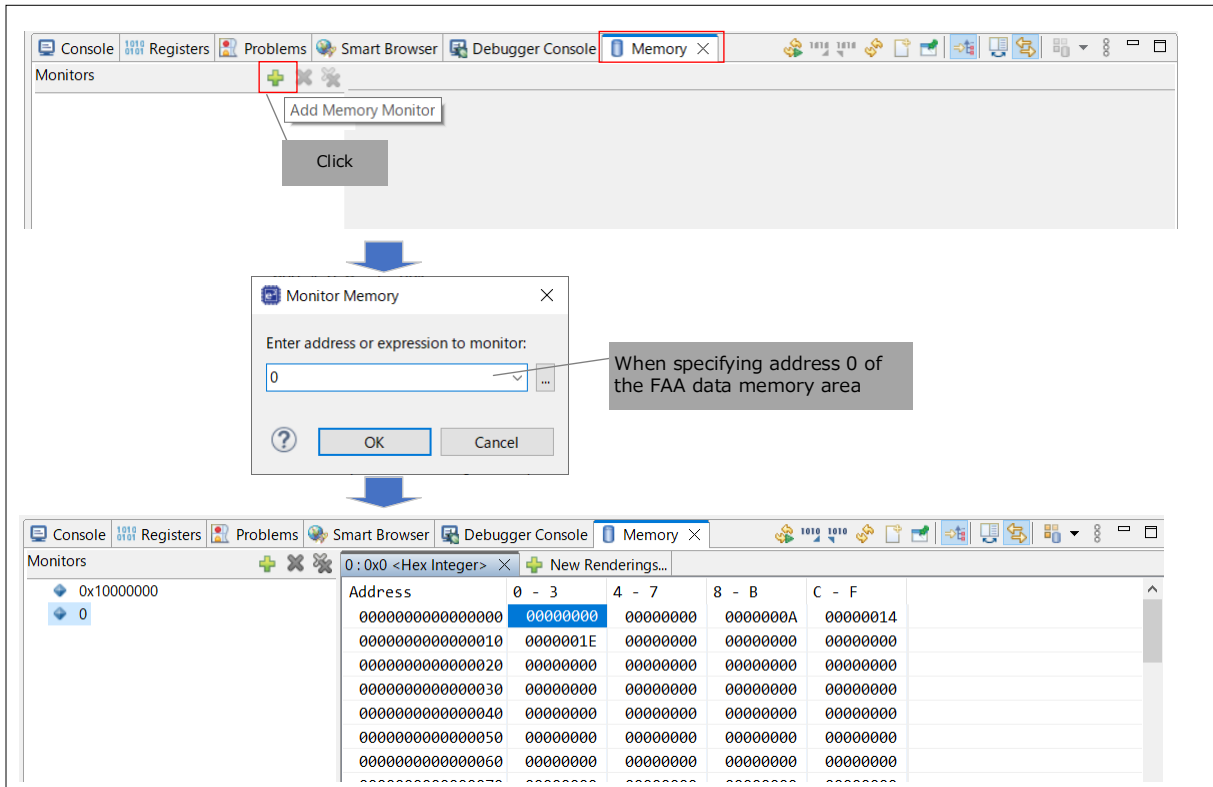
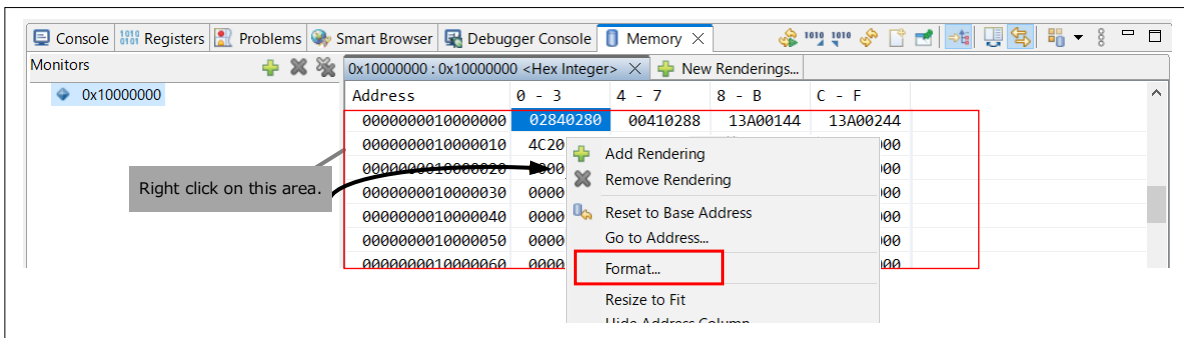

Figure 2-57 [Memory] view, FAA data memory area



Remark. The display format of the [Memory] view can be changed using the [Format] menu in the context menu.

Figure 2-58 [Memory] view, change display format



2.6.6 Symbol (Label)

When selecting FAA as the debug target, the symbols (labels) defined in the FAA program are displayed in the [Expressions] view.

The expression display control for the FAA are as follows:

- ✓ When registering symbols/labels in the expression view, delete the "_" at the beginning of the symbol (label) name. Additionally, add "(uint32_t)" before the symbol (label) name.
- ✓ Address is the FAA space address.
- ✓ If the debug target is CPU, the display contents are undefined.
- ✓ If the FAA status is the following cases, the display contents are undefined.
 - Clock is not supplied to the FAA. (FAAEN bit = 0)
 - The FAA operation is disabled. (ENB bit = 0)

Remark. To make a symbol accessible to the CPU program, it must be defined with a name starting with "_" and must be declared public in the FAA program.

Figure 2-59 [Expressions] view

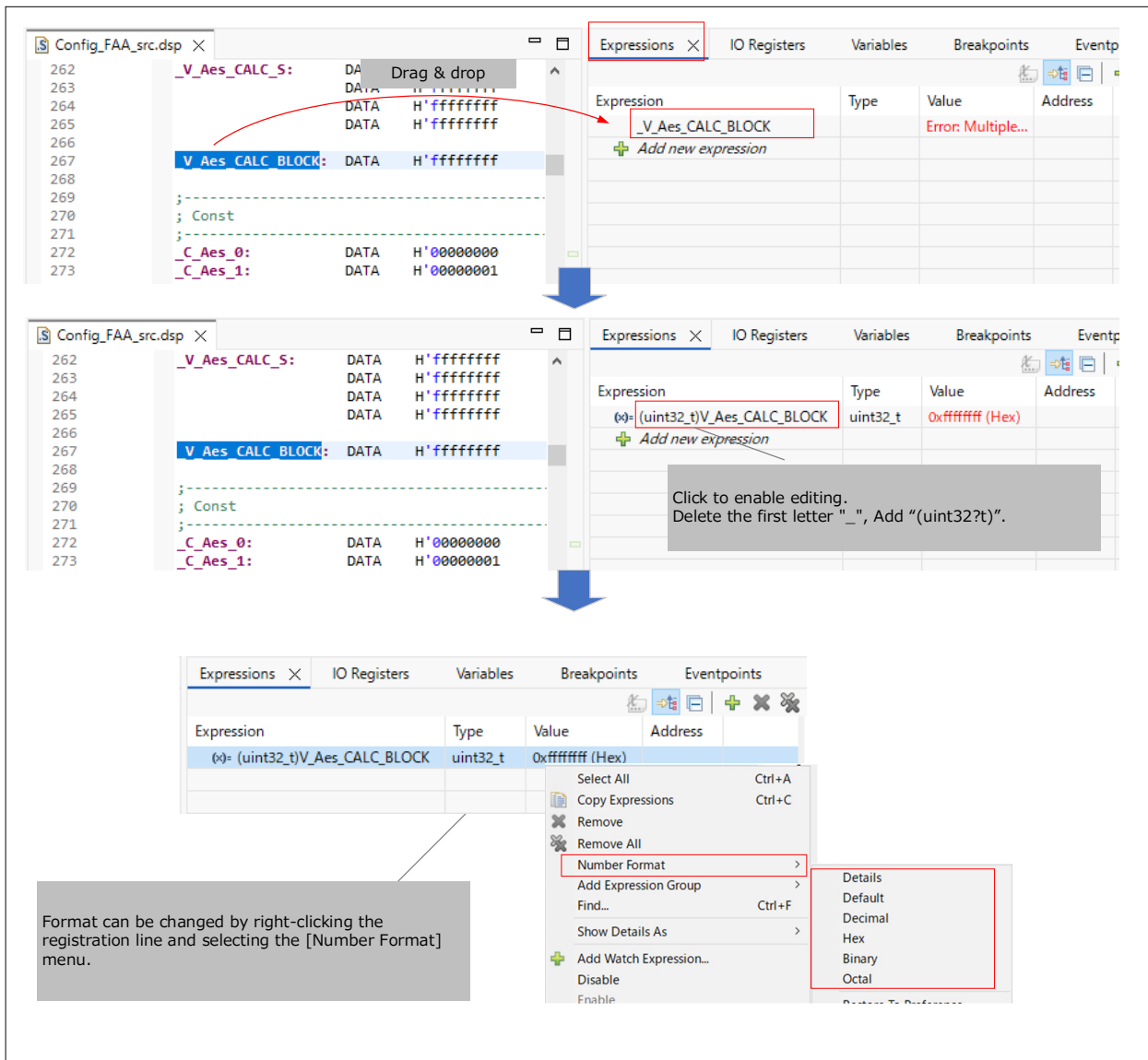

2.6.7 Register

When selecting FAA as the debug target, the operation parameter register set, address pointer set, the processor control register, etc. are displayed in the [Register] view.

Figure 2-60 [Register] view

Console		Registers X	Problems	Debugger Console	Memory	Executables
Name		Value				Description
General Registers						General Purpose and FPU Register Group
A0		0x0				
M0		0x0				
M1		0x0				
L0		0x0				
L1		0x0				
R0		0x0				
DP0		0x0				
DP1		0x0				
RP0		0x0				
FAACNT		0x0				
PG0		0x0				
FAAFLG		0x0				
SYSC		0x100				
SP0		0x0				

2.6.8 IO Register(SFR)

When selecting FAA as the debug target, the [IO Register] view displays only SFRs (Special Function Register) that FAA can access. There are two types of SFRs that the FAA can access.

- SFRs of the FAA

Registers that are not affected by the address bus select register (ADBSEL) settings and can be accessed via the FAA bus.

- Registers of the peripheral functions

Registers that can be accessed via the FAA bus when “access from the FAA” is selected in the ADBSEL register.

Remark. There are two different types of register access to the peripheral functions as described below.

- Access to a peripheral function register through the FAA address map
- Access to a peripheral function register by using the FAA address pointer (FAAAP)

For the address bus select register (ADBSEL) and how to access, refer to RL78/G24 User's Manual: Hardware (R01UH0961).

The SFR display control for the FAA are as follows:

The SFR display control for the FAA are as follows:

- ✓ The address area for the FAA SFR displays the FAA addresses.
- ✓ Access to some peripheral function SFRs is enabled by using the address bus function to permit bus access from the FAA. For such SFRs, the display name is suffixed by “_PTR”. The address displayed in the address field is the FAA address pointer values that be set in the FAA address pointer (FAAAP) when accessing using the FAAAP register.

Figure 2-61 [IO Register] view

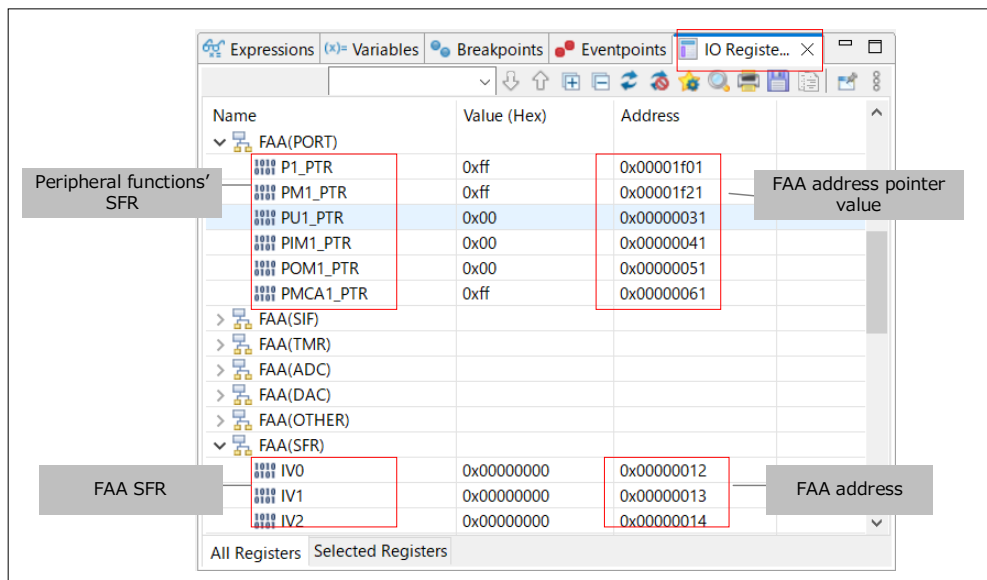

3. Sample Project

3.1 Specifications

3.1.1 Specification Overview

This sample code uses a 16-bit timer KB30 (TKB30) to perform two PWM outputs.

PWM output is connected to LED1 and LED2. Initialize TKB30 using the CPU program, count the number of TKB30 timer interrupts (INTTKB00), create a fixed cycle (500ms) timing, and start FAA operation at a fixed cycle.

The FAA program controls the LED brightness by changing the duty ratio of the PWM output. After changing the duty ratio, the operation stops.

Table 3-1 Peripheral Functions and Their Usage

Peripheral	Usage
16-bit timer KB30 (TKB30)	Output PWM from TKBO00 pin and TKBO01 pin
Flexible application accelerator (FAA)	Change the duty ratio of PWM output from TKBO00 pin and KBO01 pin

Figure 3-1 Operation overview of PWM output

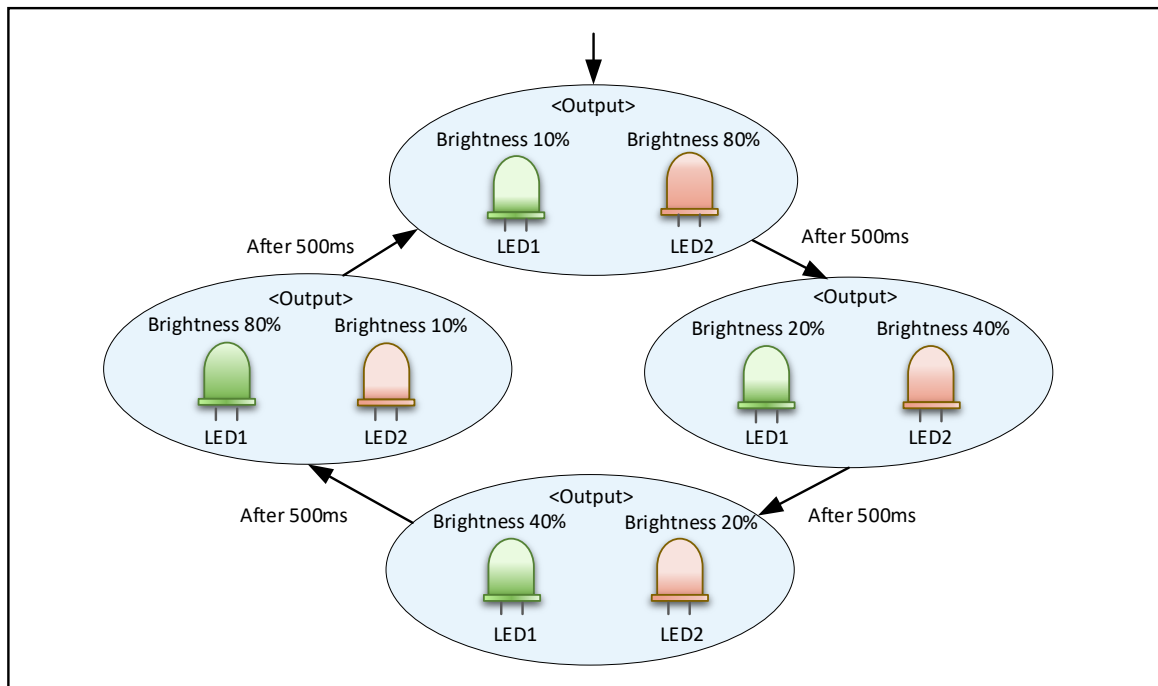

Table 3-2 Relationship between PWM output duty ratio and LED brightness

Duty ratio	Brightness
10%	10%
20%	20%
40%	40%
80%	80%

3.1.2 Operation Overview

In this sample code, 16-bit timer KB30 (TKB30) is used with the standalone mode (period controlled by the TKBCRn0 register), PWM signals are output from P12/TKBO00 and P13/TKBO01.

The PWM pulse period of TKB30 is 2ms, and the interrupts (INTTKB30) that occur in each period are counted 250 times. Start the FAA from the CPU every 500ms and change the duty ratio of PWM output with FAA.

1. [CPU program] Store the initial values of the TKBCR01 register and the TKBCR03 register in variables for checking the duty value.
2. [CPU program] Enable the TKB30 operation.
3. [CPU program] Set SFR access of the TKB30 to FAA bus.
4. [CPU program] Wait until the TKB30 interrupt occurs 250 times (500ms).
5. [CPU program] After the TKB30 starts the operation, the TKB30 interrupt occurs every 2ms.
6. [CPU program] Count the number of interrupt occurrences in the TKB30 interrupt (INTTKB30).
7. [CPU program] When TKB30 interrupt (INTTKB30) occurs 250 times (500ms), clock supply to the FAA is enabled and FAA operation is enabled.
8. [CPU program] Set the FAA stack pointer and the start address of the FAA program and start FAA operation. Then wait until the FAA program completes.
9. [FAA program] Update the compare register (TKBCR01) and change the duty ratio of TKBO00 output. And update the compare register (TKBCR03) and change the duty ratio of TKBO01 output. Every 500ms, the duty ratio of the TKBO00 output is updated by double in the order of 10% → 20% → 40% → 80%, and after the duty ratio reaches 80%, it is set to 10% again. The duty ratio of the TKBO01 output is updated by 1/2 in the order of 80% → 40% → 20% → 10%, and after the duty ratio is 10%, it is set to 80% again.
10. [FAA program] Store the updated duty ratio (values of the TKBCR01 register and the TKBCR03 register) in global variables and the FAA stops operating.
11. [CPU program] When FAA program execution is completed, clock supply to the FAA is stopped and FAA operation is disabled.
12. [CPU program] Store the updated duty ratio (values of the TKBCR01 register and the TKBCR03 register) in variables for duty value confirmation.
13. [CPU program] Return to step 4 and wait for TKB30 interrupts (INTTKB30) to occur 250 times (500ms) again.

3.2 Operation Confirmation Conditions

Table 3-3 Operation Confirmation Conditions

Item	Description
MCU	RL78/G24 (R7F101GLG)
Operating frequency	<ul style="list-style-type: none"> ▪ High-Speed On-Chip Oscillator Clock: 32MHz ▪ CPU/Peripheral Hardware Clock: 32MHz
Operating voltage	<ul style="list-style-type: none"> ▪ 3.3V (Can operate between 2.7V to 5.5V) ▪ LVD0 Operation (VLVD0): Reset Mode Rising edge = 2.97V Falling edge = 2.91V
Integrated development environment (e2 studio)	Manufactured by Renesas Electronics V2025-12
C compiler (e2 studio)	Manufactured by Renesas Electronics CC-RL V1.15.01
FAA/GREEN_DSP Structured Assembler	Manufactured by Renesas Electronics DSPASM V1.05.00
Smart Configurator (SC)	Manufactured by Renesas Electronics The version included with e2 studio v2025-12
Board Support Package (BSP)	Manufactured by Renesas Electronics V1.92
Emulator	E2 emulator Lite
Board	RL78/G24 Fast Prototyping Board (RTK7RLG240C00000BJ)

3.3 Hardware Description

3.3.1 Example of Hardware Configuration

The example of the hardware configuration used in this sample code is shown below.

Figure 3-2 Example of Hardware Configuration

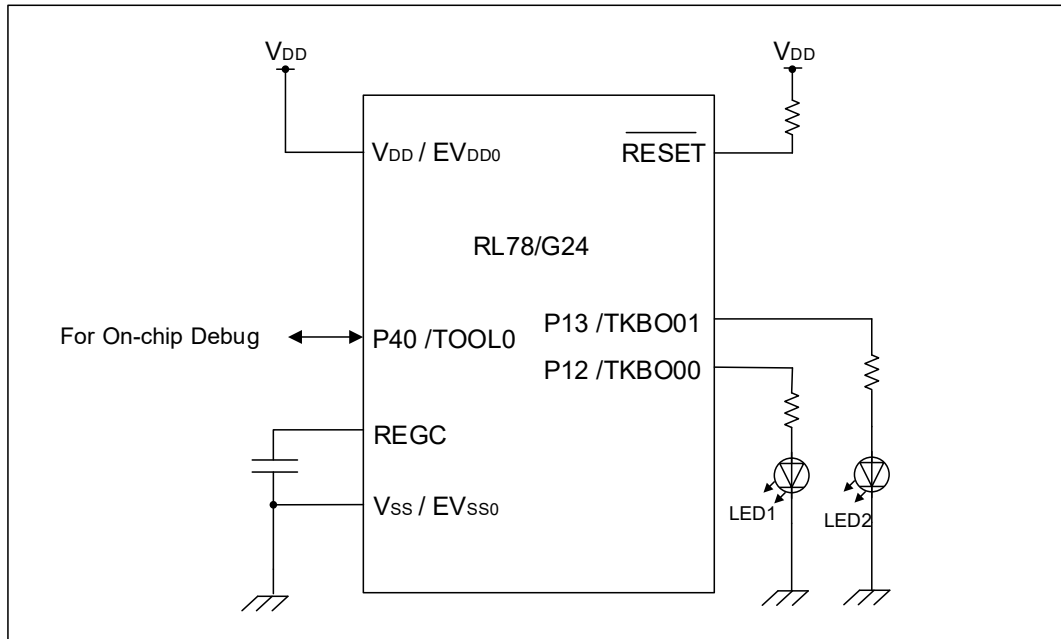

Note 1. This simplified circuit diagram was created to show an overview of connections only. When actually designing your circuit, make sure the design includes appropriate pin handling and meets electrical characteristic requirements (connect each input-only port to VDD or VSS through a resistor).

Note 2. Connect any pins whose name begins with EVSS to VSS, and any pins whose name begins with EVDD to VDD, respectively.

Note 3. VDD must not be lower than the reset release voltage (VLVD0) that is specified for the LVD0.

3.3.2 List of Used Pins

Table 3-1 shows the pins used and their function.

Table 3-4 Pins Used and their Functions

Pin name	I/O	Function
P12 / TKBO00	Output	PWM output (lighting control for LED1)
P13 / TKBO01	Output	PWM output (lighting control for LED2)

Caution. In this application note, only the used pins are processed. When actually designing your circuit, make sure the design includes sufficient pin processing and meets electrical characteristic requirements.

3.4 Software Description

3.4.1 Smart Configurator Setting

The Smart Configurator (SC) settings in this sample code are shown below. The items and settings in each SC settings table are explained using the description on the settings screen.

3.4.1.1 Clock

The clock settings used in this sample code are shown below.

Operation mode: High-speed main mode 2.7(V)~5.5(V)

EVDD setting: $2.7\text{ V} \leq \text{EVDD0} \leq 5.5\text{ V}$

High-speed on-chip oscillator: 32MHz

fCLK: 32000kHz

Figure 3-3 Clock Settings

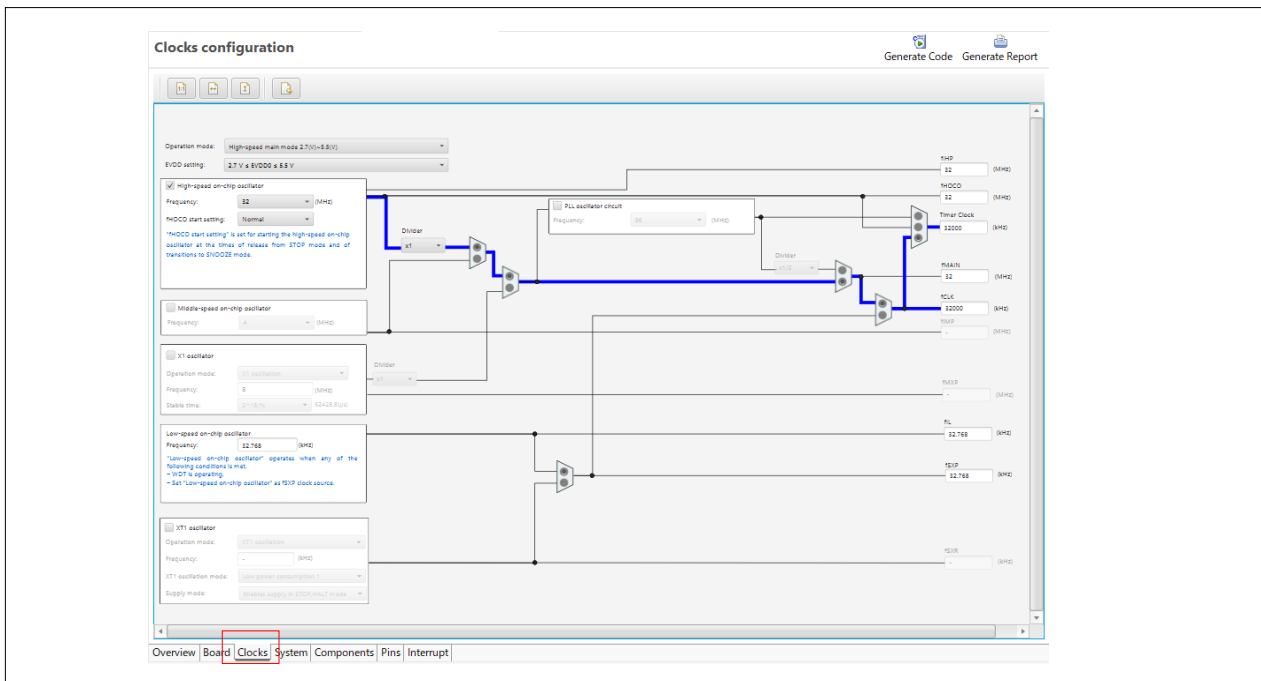

3.4.1.2 System

The system settings used in this sample code are shown below.

Figure 3-4 System Settings

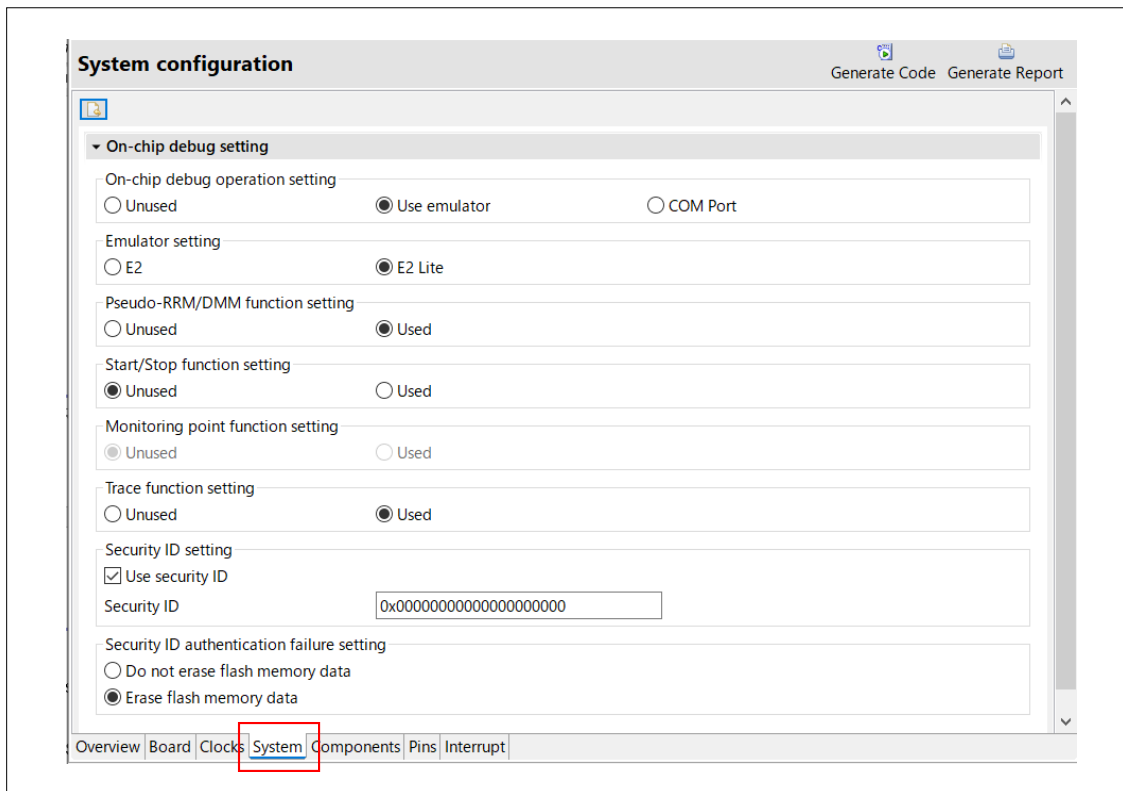

3.4.1.3 Component

The component settings used in this sample code are shown below.

Table 3-5 Component settings (LVD0)

Item	Description
Component	Voltage Detector
Configuration name	Config_LVD0
Resource	LVD0

Figure 3-5 LVD0 Settings

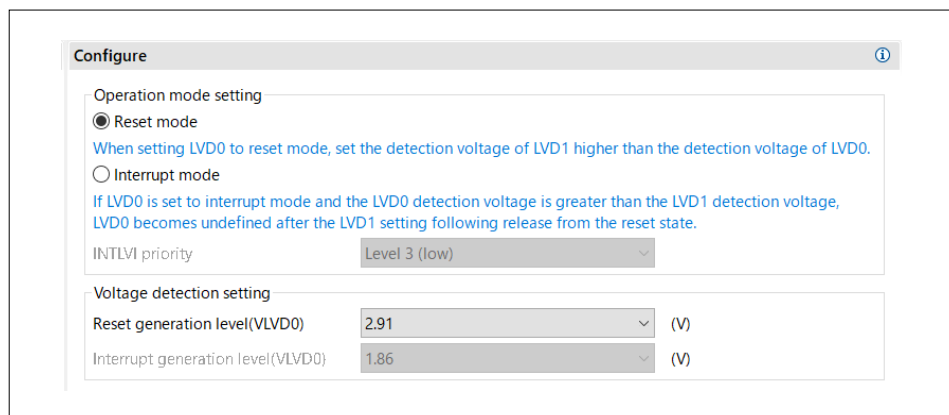

Table 3-6 Component settings (TKB30)

Item	Description
Component	PWM Output
Operation	Standalone mode (Period controlled by the TKBCRn0 register)
Configuration name	Config_TKB0
Resource	TKB0

Figure 3-6 TKB30 Settings

Configure

Count source setting

Operation clock: CK20

Clock source: fKBKC (Clock frequency: 32000 kHz, fCLK is selected as fKBKC)

PWM output setting

PWM period: 2 ms (Actual value: 2)

Duty (TKBO00 output): 10 (%) (Actual value: 10)

Duty (TKBO01 output): 80 (%) (Actual value: 80)

Delay (TKBO01 output): 0 (%) (Actual value: 0)

A/D conversion start timing signal output function setting

TKBTGCR0 value: 0

Output setting

Enable TKBO00 output

Default level: Low level

Active level: High level

Enable TKBO01 output

Default level: Low level

Active level: High level

PWM output smooth start function setting

Enable TKBO00 smooth start function

TKBO00 smooth start initial duty: 10 (%) (Actual value: 10)

TKBO00 smooth start step width: 1

Enable TKBO01 smooth start function

TKBO01 smooth start initial duty: 10 (%) (Actual value: 10)

TKBO01 smooth start step width: 1

Interrupt setting

Generate interrupt when TKBO00 forced stopping of the output is terminated

Priority: Level 3 (low)

Generate interrupt when TKBO00 forced stopping of the output is activated

Priority: Level 3 (low)

Generate interrupt when TKBO01 forced stopping of the output is terminated

Priority: Level 3 (low)

Generate interrupt when TKBO01 forced stopping of the output is activated

Priority: Level 3 (low)

Enable 16-bit timer KTB30 end count

Priority: Level 3 (low)

Table 3-7 Component settings (FAA)

Item	Description
Component	Flexible Application Accelerator
Configuration name	Config_FAA

Figure 3-7 FAA Settings

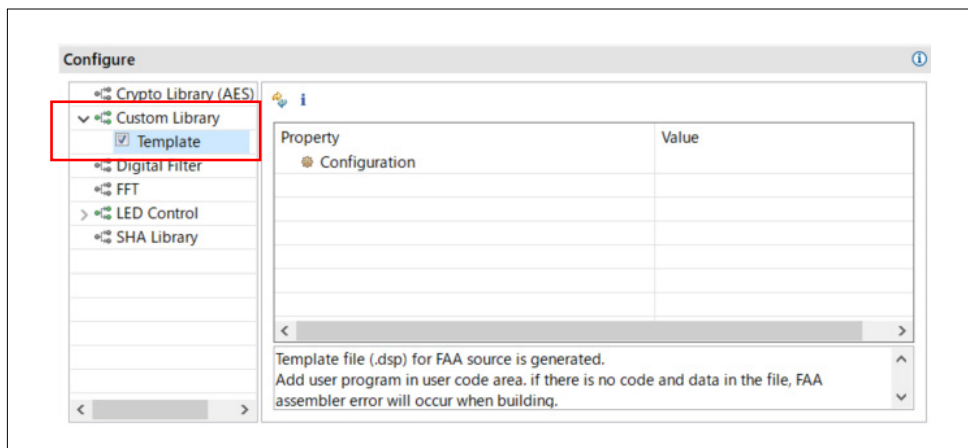

Remark. If any FAA library is not displayed after the sample project is opened, refer to step 11 in 2.3.1 Adding FAA Component to download FAA libraries.

3.4.2 Folder Structure

Table 3-8 shows the structure of the source files/header files used in the sample project.

Table 3-8 Folder Structure

Folder, File name	Description	Generated by SC
\sample_project<DIR>	Sample project folder	
\src<DIR>	Program storage folder	√
sample_project.c	Sample source file	√ Note 1
\smc_gen<DIR>	Smart Configurator generated folder	√
\Config_FAA<DIR>	FAA program storage folder	√
Config_FAA_common.c	Common FAA module source file	√
Config_FAA_common.h	Common FAA module header file	√
Config_FAA_common.inc	Include file for FAA assembly source file	√
Config_FAA_src.dsp	FAA assembly source file	√ Note 2
\Config_TKB0<DIR>	TKB30 program storage folder	√
Config_TKB0.c	TKB30 source file	√
Config_TKB0.h	TKB30 header file	√
Config_TKB0_user.c	TKB30interrupt source file	√ Note 3
¥general<DIR>	Initialization and common program storage folder	√
¥r_bsp<DIR>	BSP program storage folder	√
¥r_config<DIR>	Configuration header storage folder	√

Note. "<DIR>" indicates a directory.

Note 1. Sample code has been added.

Note 2. This sample project uses the Custom Library of FAA library. Therefore, file content is only a template and no code right after the file is generated. Sample code has been added for this sample project.

Note 3. Sample code has been added in the user code area of SC.

3.4.3 Option Byte Settings

Table 3-9 shows the option byte settings.

Table 3-9 Option Byte Settings

Address	Setting value	Description
000C0H/040C0H	1110 1111B (EFH)	Watchdog Timer stopped operation (Count stops after reset release)
000C1H/040C1H	1111 1011B (FBH)	LVD0 reset mode. Detection voltage: Rising 2.97V / Falling 2.91V
000C2H/040C2H	1110 1000B (E8H)	lash operation mode: High-speed main mode. High-speed on-chip oscillator frequency: 32MHz
000C3H/040C3H	1000 0100B (84H)	On-chip debug operation enabled

3.4.4 List of Constants

Table 3-10 and Table 3-11 show constants used in the sample code.

Table 3-10 Constants (CPU program)

Constant name	Value	Description	Function that uses the constant
FAA_BUS_ACCESS	0200H	Enable to access TKB30 register from FAA. (ADBSEL setting value)	main

Table 3-11 Constans (FAA program)

Constant name	Value	Description
_C_TKBO00_DUTY_INIT	1900H	Initial duty ratio for TKBO00 output (TKBCR01 setting value)
_C_TKBO01_DUTY_INIT	C800H	Initial duty ratio for TKBO01 output (TKBCR03 setting value)
_C_TKBTRG_TKBRDT_REQ	1H	Batch overwrite request of TKB30 compare register (TKBRDT0 setting value)

3.4.5 List of Variables

Table 3-12 and Table 3-13 show variables used in the sample code.

Table 3-12 Variables (CPU program)

Type	Variable name	Description	Function that uses the variable
uint32_t	g_work_tkbo00	Variable to check the current duty ratio for TKBO00 output (Value of TKBCR01)	main
uint32_t	g_work_tkbo01	Variable to check the current duty ratio for TKBO01 output (Value of TKBCR03)	main
uint8_t	g_tkb_interrupt_flag	500ms elapsed flag	r_Config_TKB0_end _count_interrupt

Table 3-13 Variables (FAA program)

Size	Variable name	Description
4 bytes	_V_TKBO00_DUTY	Storage the updated duty ratio for TKBO00 output (TKBCR01 setting value)
4 bytes	_V_TKBO01_DUTY	Storage the updated duty ratio for TKBO01 output (TKBCR03 setting value)

3.4.6 List of Functions

Table 3-14 and Table 3-15 show functions and processing used in the sample code. However, functions generated by the Smart Configurator that have not been modified are excluded.

Table 3-14 Functions (CPU program)

Function name	Description	Source file
main	main process	main.c
r_Config_TKB0_end_count_interrupt	TKB30 interrupt processing (Count the number of INTTKB00 occurrences)	Config_TKB0_user.c

Table 3-15 Processing (FAA program)

Label name	Description	Source file
_P_TKB_PWM	Change the duty ratio of TKBO00 and TKBO01 output	Config_FAA_src.dsp

3.4.7 Function Specification

The function specifications of the sample code are shown below.

CPU program

[Function name]	main()
Outline	main process
Header	r_smc_entry.h、 Config_TKB0.h
Declaration	void main(void)
Description	Start operation of the Timer TKB30, and start operation of the FAA every 500ms.
Argument	-
Return value	-

CPU program

[Function name]	r_Config_TKB0_end_count_interrupt()
Outline	Timer TKB30 interrupt processing
Header	r_cg_macrodriver.h、 r_cg_userdefine.h、 Config_TKB0.h
Declaration	static void __near r_Config_TKB0_end_count_interrupt(void)
Description	Count INTTKB30 occurrences and set the 500ms elapsed flag every 250 interrupts (500ms elapsed).
Argument	-
Return value	-

FAA program

[Label name]	_P_TKB_PWM
Outline	Change processing of the duty ratio for TKBO00 and TKBO01 output
Header	Config_FAA_common.inc
Declaration	-
Description	Change the duty ratio for TKBO00 and TKBO01 output.
Argument	-
Return value	-

3.4.8 Flowchart

3.4.8.1 Main Process

Figure 3-8 shows the flowchart for the main process.

Figure 3-8 Main process

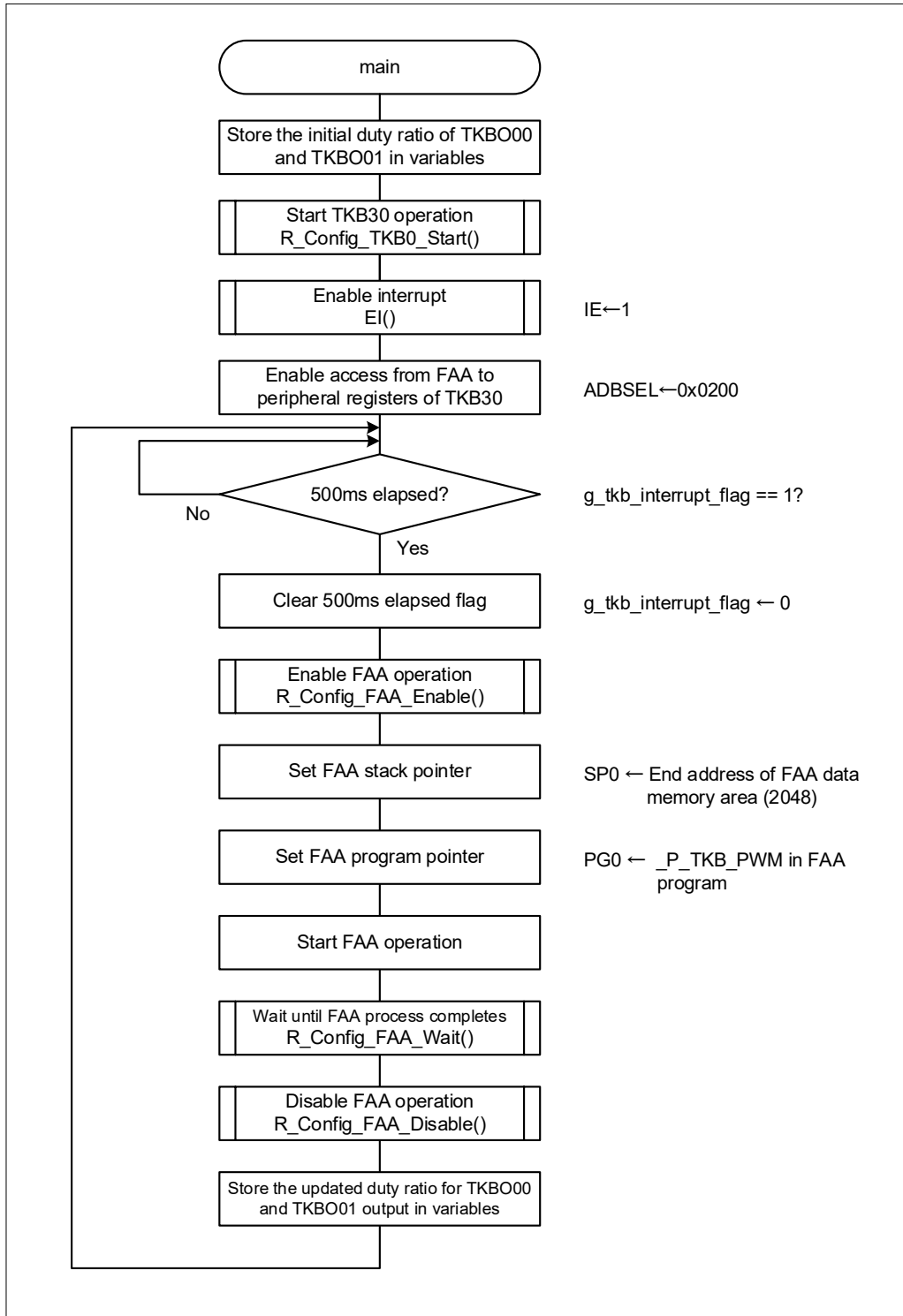

3.4.8.2 r_Config_TKB0_end_count_interrupt Function

Figure 3-9 shows the flowchart of the r_Config_TKB0_end_count_interrupt function.

Figure 3-9 r_Config_TKB0_end_count_interrupt function

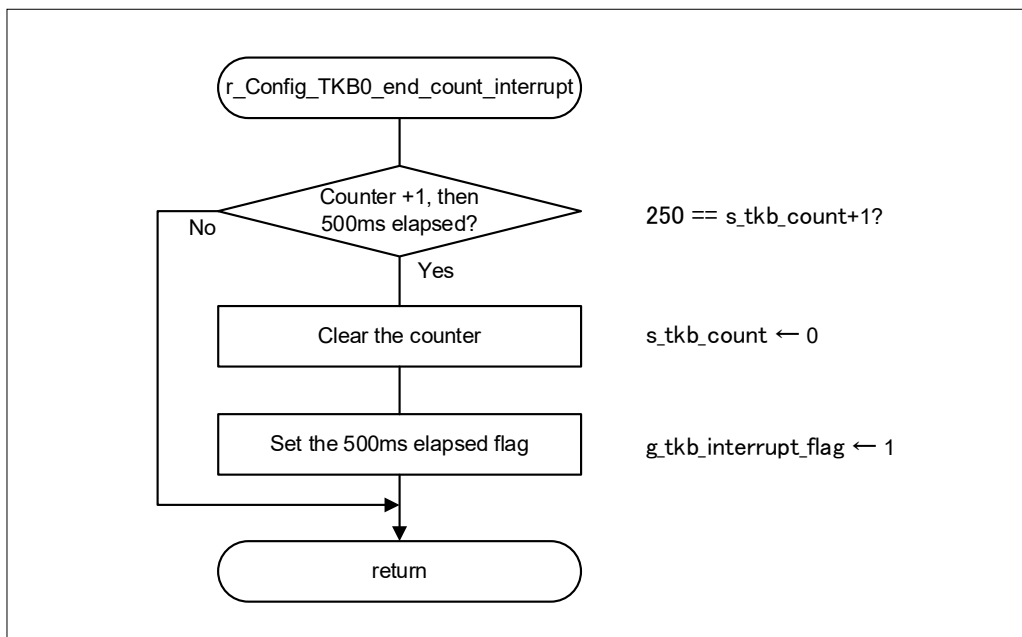

3.4.8.3 FAA Processing

Figure 3-10 shows the flowchart of the r_Config_TKBO_end_count_interrupt function.

Figure 3-10 FAA processing

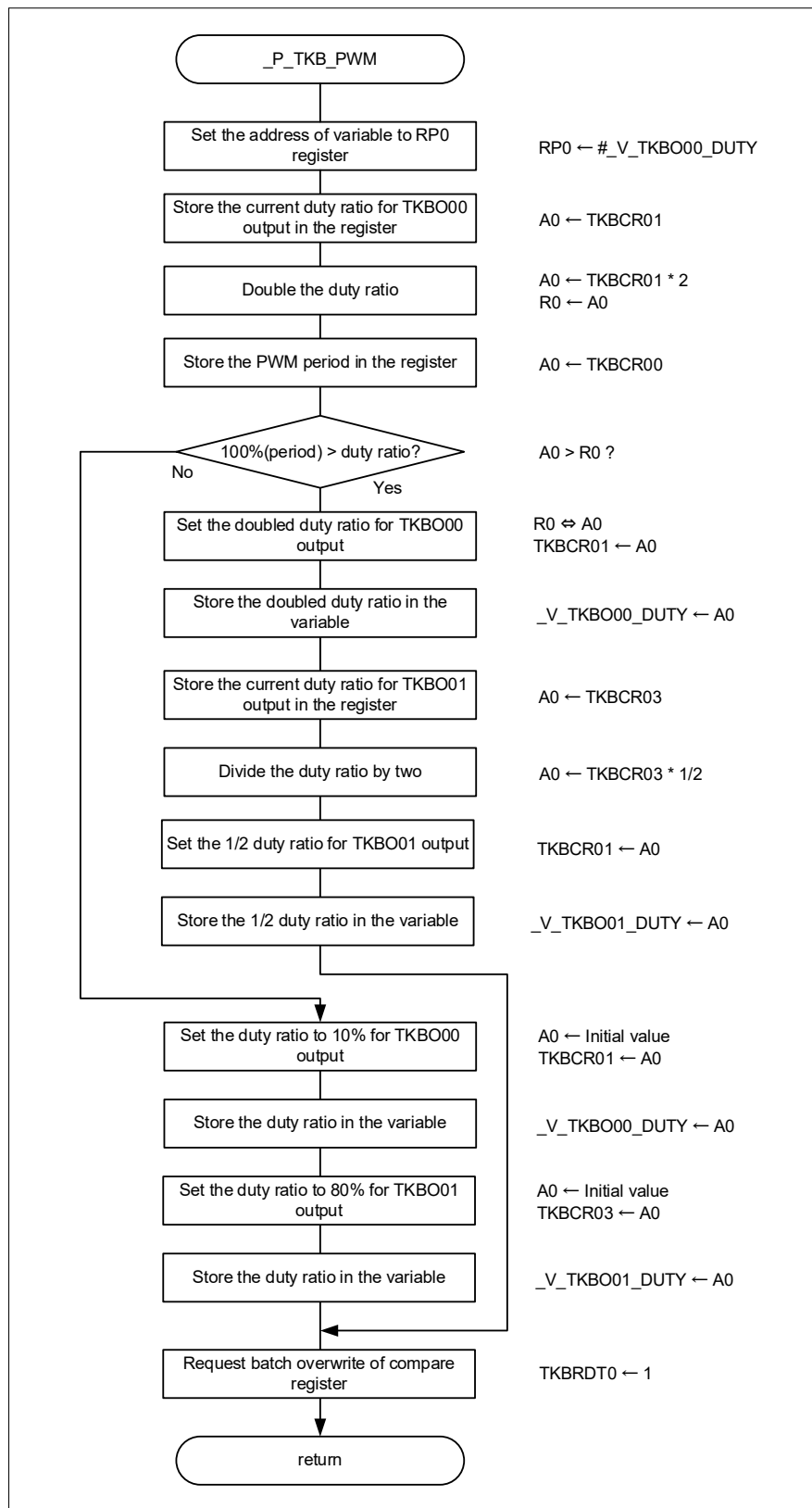

3.5 Basic debug operations

This section explains the basic operations of debugging a FAA program using sample code and sample scripts.

Procedure:

1. Connect the RL78/G24 Fast Prototyping Board to the PC.
2. Start the e2 studio and import the sample project. The sample project is configured for E2 emulator Lite connection. If you want to use a COM port connection, change the settings by [Run] – [Debug Configurations...] menu in the e2 studio.
3. Build the sample program. (Refer to 2.4.3 Program Building)
4. Download the sample program to RL78/G24 Fast Prototyping Board. (Refer to 2.5.3 Program Download)
5. Select the CPU as the debug target. (Refer to 2.6.1 Debug Target)
6. To debug the FAA program, the FAA must be in an enabled state (FAAEN = 1, ENB = 1). Execute the CPU program up to the code that enables the FAA operation
 Open the sample_project.c. Open the context menu at the address row of "FAACNT = 0x0001U;" to set the breakpoint (Software break). Click the [Toggle Software Breakpoint] in the context menu. Additionally, open the FAA program source file Config_FAA_src.dsp in advance.

Figure 3-11 sample_project.c (Debug target: CPU)

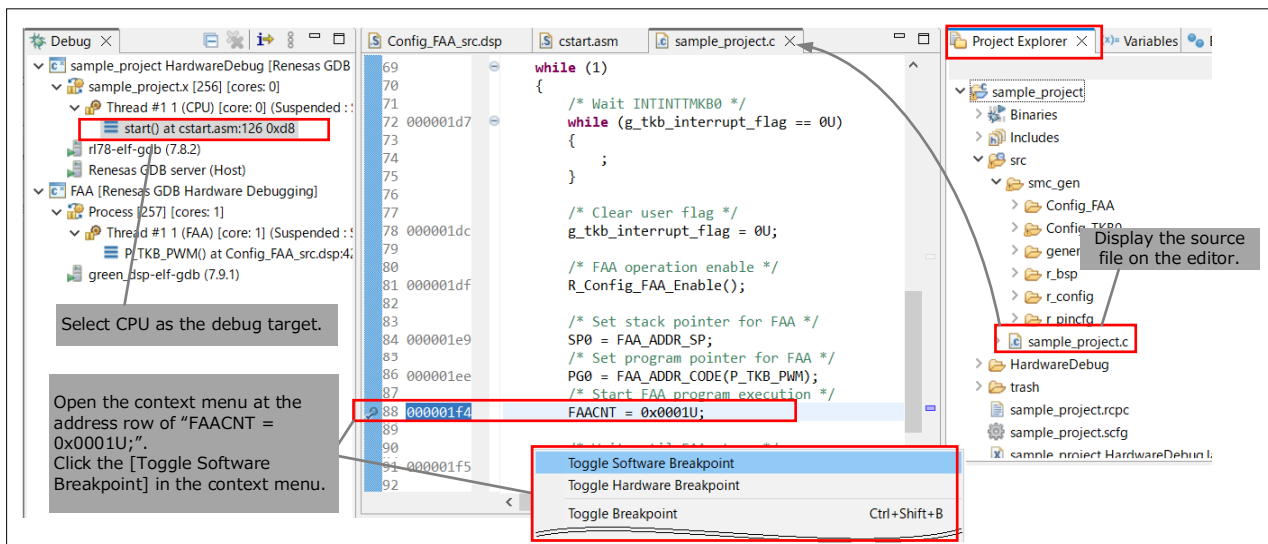

Remark1. FAA is enabled using R_Config_FAA_Enable() function.

Remark2. There are two types of breakpoints: hardware breakpoints (break after execution) and software breakpoints (break before execution).

7. Click the [Reset] and then click the [Resume] on the tool bar. The program will run to the beginning of the main function and stop, so click the [Resume] again.

Figure 3-12 Debug Tool bar

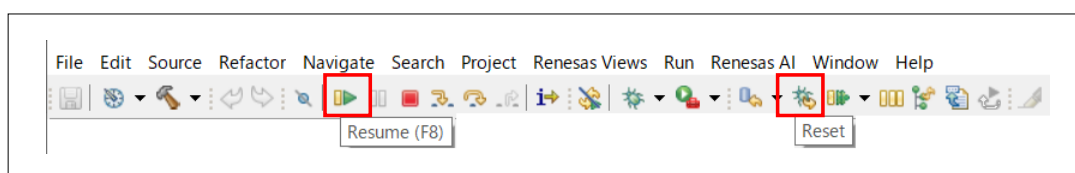

- After the program stopped by the breakpoint, change the debug target to the FAA. If the FAA program source file is not displayed after changing the debug target, click the [Refresh all] button.

Figure 3-13 Debug Tool bar

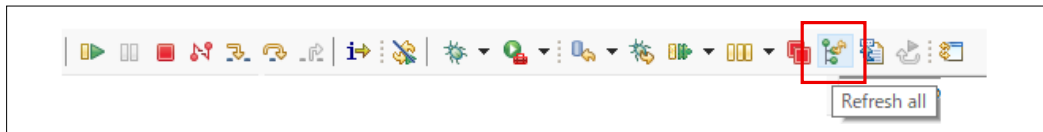

- To watch variables:
 Register variables (`_V_TKBO00_DUTY`, `_V_TKBO01_DUTY`) whose values are watched in the FAA program to the [Expressions] view.
 - After registering the variable, delete the first letter “_” and add “(uint32_t)” before the symbol (label) name. if necessary, change the format to hexadecimal notation. (Refer to 2.6.6 Symbol (Label))

Figure 3-14 [Expressions] view

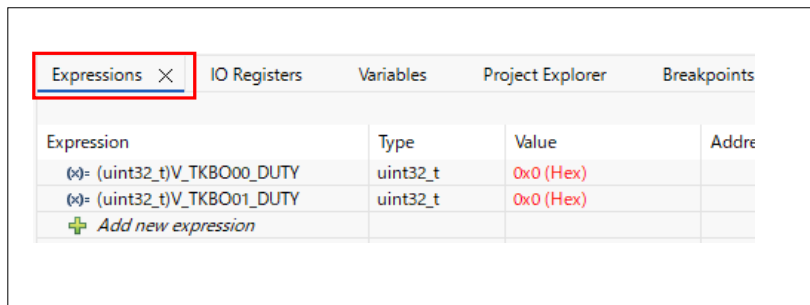

- To watch SFRs:
 Register SFRs (`TKBCR01_PTR`, `TKBCR03_PTR`) whose values are watched in the FAA program to the [Selected Register] tab of [IO Register] view.

Figure 3-15 [IO Register] view

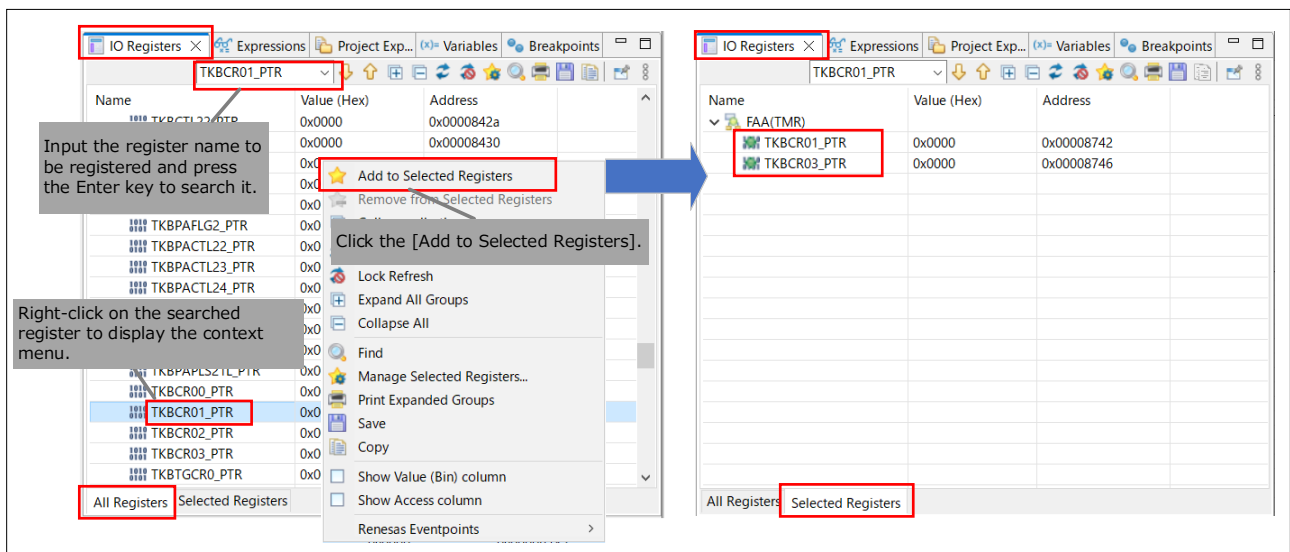

11. Step-execute/execute the FAA program and debug while checking the values of variables, SFRs, and registers.
 - Breakpoints can be set by clicking in the main area of the FAA program source. (Refer to 2.6.4 Breakpoint)

Figure 3-16 Example of FAA program debugger screen

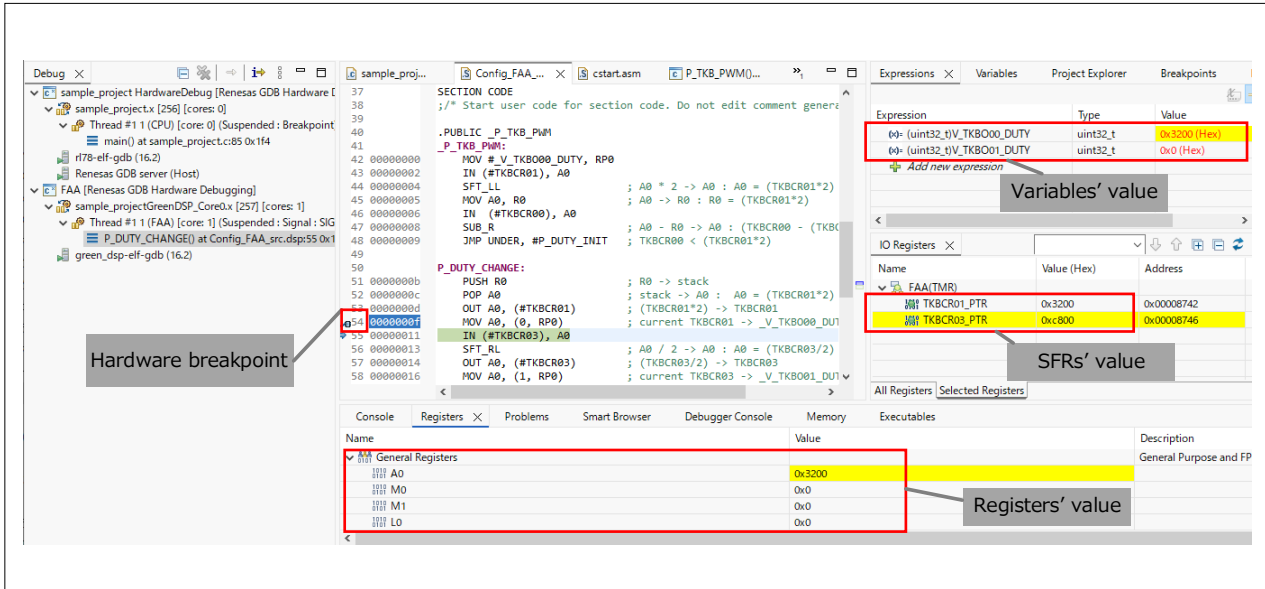

4. Sample Code

Sample code can be downloaded from the Renesas Electronics website.

5. Reference Documents

RL78/G24 User's Manual: Hardware (R01UH0961)

RL78 family User's Manual: Software (R01US0015)

DSPASM FAA/GREEN_DSP Structured Assembler User's Manual (R20UT3911)

RL78/G24 Fast Prototyping Board User's Manual (R20UT5091)

RL78 Smart Configurator User's Guide: e2 studio (R20AN0579)

(The latest version can be downloaded from the Renesas Electronics website.)

Technical Update/Technical News

(The latest version can be downloaded from the Renesas Electronics website.)

All trademarks and registered trademarks are the property of their respective owners.

Revision History

Rev.	Date	Description	
		Page	Summary
1.00	Nov.14.23	-	First edition
1.10	Jan.13.26	5	Figure1-4: Modification
		6	1.3.2: Addition of description 1.3.3: Addition of Remark
		8	Table2-1: Modification of tool version Table2-2: Addition of Note1
		18	Figure2-21: Modification
		19	Figure2-22: Modification Figure2-23: Modification Figure2-24: Modification
		20	Figure2-25: Modification
		21	Figure2-28: Modification, Addition of Remark1 19: Addition of Link
		22	Table2-4: Addition of function name of transfer processing Table2-4: Modification of some description under the table
		23	Note2: Modification of description
		30	Table2-10: Addition of Note1
		34	Caution2: Addition of function name of transfer processing
		37	2.6.3: Modification of some description of Go/Stop
		38	2.6.3: Addition of some description of Go/Stop
		39	2.6.4: Addition of description of Breakpoint
		42	Figure2-59: Modification
		44	2.6.8: Deletion of some description of IO Register (SFR) display
		47	Table 3-3: Modification of tool version
		49	Figure3-3: Modification
		53	Table 3-8: Deletion of script file from Folder Structure
		-	Deletion of 3.5 Sample script specification
59	3.5: Change procedure of Basic debug operations		
60	Figure3-14: Modification		

General Precautions in the Handling of Microprocessing Unit and Microcontroller Unit Products

The following usage notes are applicable to all Microprocessing unit and Microcontroller unit products from Renesas. For detailed usage notes on the products covered by this document, refer to the relevant sections of the document as well as any technical updates that have been issued for the products.

1. Precaution against Electrostatic Discharge (ESD)

A strong electrical field, when exposed to a CMOS device, can cause destruction of the gate oxide and ultimately degrade the device operation. Steps must be taken to stop the generation of static electricity as much as possible, and quickly dissipate it when it occurs. Environmental control must be adequate. When it is dry, a humidifier should be used. This is recommended to avoid using insulators that can easily build up static electricity.

Semiconductor devices must be stored and transported in an anti-static container, static shielding bag or conductive material. All test and measurement tools including work benches and floors must be grounded. The operator must also be grounded using a wrist strap. Semiconductor devices must not be touched with bare hands. Similar precautions must be taken for printed circuit boards with mounted semiconductor devices.

2. Processing at power-on

The state of the product is undefined at the time when power is supplied. The states of internal circuits in the LSI are indeterminate and the states of register settings and pins are undefined at the time when power is supplied. In a finished product where the reset signal is applied to the external reset pin, the states of pins are not guaranteed from the time when power is supplied until the reset process is completed. In a similar way, the states of pins in a product that is reset by an on-chip power-on reset function are not guaranteed from the time when power is supplied until the power reaches the level at which resetting is specified.

3. Input of signal during power-off state

Do not input signals or an I/O pull-up power supply while the device is powered off. The current injection that results from input of such a signal or I/O pull-up power supply may cause malfunction and the abnormal current that passes in the device at this time may cause degradation of internal elements. Follow the guideline for input signal during power-off state as described in your product documentation.

4. Handling of unused pins

Handle unused pins in accordance with the directions given under handling of unused pins in the manual. The input pins of CMOS products are generally in the high-impedance state. In operation with an unused pin in the open-circuit state, extra electromagnetic noise is induced in the vicinity of the LSI, an associated shoot-through current flows internally, and malfunctions occur due to the false recognition of the pin state as an input signal become possible.

5. Clock signals

After applying a reset, only release the reset line after the operating clock signal becomes stable. When switching the clock signal during program execution, wait until the target clock signal is stabilized. When the clock signal is generated with an external resonator or from an external oscillator during a reset, ensure that the reset line is only released after full stabilization of the clock signal. Additionally, when switching to a clock signal produced with an external resonator or by an external oscillator while program execution is in progress, wait until the target clock signal is stable.

6. Voltage application waveform at input pin

Waveform distortion due to input noise or a reflected wave may cause malfunction. If the input of the CMOS device stays in the area between V_{IL} (Max.) and V_{IH} (Min.) due to noise, for example, the device may malfunction. Take care to prevent chattering noise from entering the device when the input level is fixed, and also in the transition period when the input level passes through the area between V_{IL} (Max.) and V_{IH} (Min.).

7. Prohibition of access to reserved addresses

Access to reserved addresses is prohibited. The reserved addresses are provided for possible future expansion of functions. Do not access these addresses as the correct operation of the LSI is not guaranteed.

8. Differences between products

Before changing from one product to another, for example to a product with a different part number, confirm that the change will not lead to problems. The characteristics of a microprocessing unit or microcontroller unit products in the same group but having a different part number might differ in terms of internal memory capacity, layout pattern, and other factors, which can affect the ranges of electrical characteristics, such as characteristic values, operating margins, immunity to noise, and amount of radiated noise. When changing to a product with a different part number, implement a system-evaluation test for the given product.

Notice

1. Descriptions of circuits, software and other related information in this document are provided only to illustrate the operation of semiconductor products and application examples. You are fully responsible for the incorporation or any other use of the circuits, software, and information in the design of your product or system. Renesas Electronics disclaims any and all liability for any losses and damages incurred by you or third parties arising from the use of these circuits, software, or information.
2. Renesas Electronics hereby expressly disclaims any warranties against and liability for infringement or any other claims involving patents, copyrights, or other intellectual property rights of third parties, by or arising from the use of Renesas Electronics products or technical information described in this document, including but not limited to, the product data, drawings, charts, programs, algorithms, and application examples.
3. No license, express, implied or otherwise, is granted hereby under any patents, copyrights or other intellectual property rights of Renesas Electronics or others.
4. You shall be responsible for determining what licenses are required from any third parties, and obtaining such licenses for the lawful import, export, manufacture, sales, utilization, distribution or other disposal of any products incorporating Renesas Electronics products, if required.
5. You shall not alter, modify, copy, or reverse engineer any Renesas Electronics product, whether in whole or in part. Renesas Electronics disclaims any and all liability for any losses or damages incurred by you or third parties arising from such alteration, modification, copying or reverse engineering.
6. Renesas Electronics products are classified according to the following two quality grades: "Standard" and "High Quality". The intended applications for each Renesas Electronics product depends on the product's quality grade, as indicated below.
 - "Standard": Computers; office equipment; communications equipment; test and measurement equipment; audio and visual equipment; home electronic appliances; machine tools; personal electronic equipment; industrial robots; etc.
 - "High Quality": Transportation equipment (automobiles, trains, ships, etc.); traffic control (traffic lights); large-scale communication equipment; key financial terminal systems; safety control equipment; etc.Unless expressly designated as a high reliability product or a product for harsh environments in a Renesas Electronics data sheet or other Renesas Electronics document, Renesas Electronics products are not intended or authorized for use in products or systems that may pose a direct threat to human life or bodily injury (artificial life support devices or systems; surgical implantations; etc.), or may cause serious property damage (space system; undersea repeaters; nuclear power control systems; aircraft control systems; key plant systems; military equipment; etc.). Renesas Electronics disclaims any and all liability for any damages or losses incurred by you or any third parties arising from the use of any Renesas Electronics product that is inconsistent with any Renesas Electronics data sheet, user's manual or other Renesas Electronics document.
7. No semiconductor product is absolutely secure. Notwithstanding any security measures or features that may be implemented in Renesas Electronics hardware or software products, Renesas Electronics shall have absolutely no liability arising out of any vulnerability or security breach, including but not limited to any unauthorized access to or use of a Renesas Electronics product or a system that uses a Renesas Electronics product. RENESAS ELECTRONICS DOES NOT WARRANT OR GUARANTEE THAT RENESAS ELECTRONICS PRODUCTS, OR ANY SYSTEMS CREATED USING RENESAS ELECTRONICS PRODUCTS WILL BE INVULNERABLE OR FREE FROM CORRUPTION, ATTACK, VIRUSES, INTERFERENCE, HACKING, DATA LOSS OR THEFT, OR OTHER SECURITY INTRUSION ("Vulnerability Issues"). RENESAS ELECTRONICS DISCLAIMS ANY AND ALL RESPONSIBILITY OR LIABILITY ARISING FROM OR RELATED TO ANY VULNERABILITY ISSUES. FURTHERMORE, TO THE EXTENT PERMITTED BY APPLICABLE LAW, RENESAS ELECTRONICS DISCLAIMS ANY AND ALL WARRANTIES, EXPRESS OR IMPLIED, WITH RESPECT TO THIS DOCUMENT AND ANY RELATED OR ACCOMPANYING SOFTWARE OR HARDWARE, INCLUDING BUT NOT LIMITED TO THE IMPLIED WARRANTIES OF MERCHANTABILITY, OR FITNESS FOR A PARTICULAR PURPOSE.
8. When using Renesas Electronics products, refer to the latest product information (data sheets, user's manuals, application notes, "General Notes for Handling and Using Semiconductor Devices" in the reliability handbook, etc.), and ensure that usage conditions are within the ranges specified by Renesas Electronics with respect to maximum ratings, operating power supply voltage range, heat dissipation characteristics, installation, etc. Renesas Electronics disclaims any and all liability for any malfunctions, failure or accident arising out of the use of Renesas Electronics products outside of such specified ranges.
9. Although Renesas Electronics endeavors to improve the quality and reliability of Renesas Electronics products, semiconductor products have specific characteristics, such as the occurrence of failure at a certain rate and malfunctions under certain use conditions. Unless designated as a high reliability product or a product for harsh environments in a Renesas Electronics data sheet or other Renesas Electronics document, Renesas Electronics products are not subject to radiation resistance design. You are responsible for implementing safety measures to guard against the possibility of bodily injury, injury or damage caused by fire, and/or danger to the public in the event of a failure or malfunction of Renesas Electronics products, such as safety design for hardware and software, including but not limited to redundancy, fire control and malfunction prevention, appropriate treatment for aging degradation or any other appropriate measures. Because the evaluation of microcomputer software alone is very difficult and impractical, you are responsible for evaluating the safety of the final products or systems manufactured by you.
10. Please contact a Renesas Electronics sales office for details as to environmental matters such as the environmental compatibility of each Renesas Electronics product. You are responsible for carefully and sufficiently investigating applicable laws and regulations that regulate the inclusion or use of controlled substances, including without limitation, the EU RoHS Directive, and using Renesas Electronics products in compliance with all these applicable laws and regulations. Renesas Electronics disclaims any and all liability for damages or losses occurring as a result of your noncompliance with applicable laws and regulations.
11. Renesas Electronics products and technologies shall not be used for or incorporated into any products or systems whose manufacture, use, or sale is prohibited under any applicable domestic or foreign laws or regulations. You shall comply with any applicable export control laws and regulations promulgated and administered by the governments of any countries asserting jurisdiction over the parties or transactions.
12. It is the responsibility of the buyer or distributor of Renesas Electronics products, or any other party who distributes, disposes of, or otherwise sells or transfers the product to a third party, to notify such third party in advance of the contents and conditions set forth in this document.
13. This document shall not be reprinted, reproduced or duplicated in any form, in whole or in part, without prior written consent of Renesas Electronics.
14. Please contact a Renesas Electronics sales office if you have any questions regarding the information contained in this document or Renesas Electronics products.

(Note1) "Renesas Electronics" as used in this document means Renesas Electronics Corporation and also includes its directly or indirectly controlled subsidiaries.

(Note2) "Renesas Electronics product(s)" means any product developed or manufactured by or for Renesas Electronics.

(Rev.5.0-1 October 2020)

Corporate Headquarters

TOYOSU FORESIA, 3-2-24 Toyosu,
Koto-ku, Tokyo 135-0061, Japan
www.renesas.com

Trademarks

Renesas and the Renesas logo are trademarks of Renesas Electronics Corporation. All trademarks and registered trademarks are the property of their respective owners.

Contact information

For further information on a product, technology, the most up-to-date version of a document, or your nearest sales office, please visit:
www.renesas.com/contact/.