

# RTK0EE0017D11004BJ

## Electrical Characteristics of 920-MHz-Band RF Transceiver (ARIB STD-T108)

### Introduction

This document shows the electrical characteristics measurement results in the 920 MHz band with the RF transceiver (R9A06G062GNP+front-end module+RX65N).

The front-end module (FEM) consists of Switch (SW), Power amplifier (PA) and Low noise amplifier (LNA).

The target regulation is "ARIB STD-T108" and the frequency band is 920MHz to 928MHz.

The evaluation board (RTK0EE0017D11004BJ) used in this document is mounted with circuit constants that comply with ARIB standards. For details, please refer to the Example of Peripheral Circuit and BOM List at the end of this document.

Note: The contents of this document are provided as an example for reference and do not guarantee the signal quality in systems. When implementing this example into an existing system, thoroughly evaluate the product in the overall system and apply the contents of this document at your own responsibility.

### Target Device

R9A06G062GNP

### Contents

1. Evaluation condition.....	3
1.1 System configuration.....	3
1.2 Temperature and supply voltage conditions .....	3
1.3 FSK setting commands .....	4
1.3.1 FSK transmission setting commands.....	4
1.3.2 FSK receive setting commands.....	4
1.4 OFDM setting commands.....	5
1.4.1 OFDM transmission setting commands .....	5
1.4.2 OFDM receive setting commands .....	5
2. Electrical Characteristics .....	6
2.1 Current Characteristics.....	6
2.1.1 FSK (100kbps, modulation index = 1).....	6
2.1.2 OFDM (Option3, MCS6).....	6
2.2 TX Electrical Characteristics .....	7
2.2.1 FSK (100kbps, modulation index = 1).....	7
2.2.2 OFDM (Option3, MCS6).....	12
2.2.3 OFDM (Option4, MCS6).....	17
2.3 RX Electrical Characteristics .....	22
2.3.1 FSK (100kbps, modulation index = 1).....	22
2.3.2 OFDM (Option3, MCS6).....	26
2.3.3 OFDM (Option4, MCS6).....	30
3. Example of Peripheral Circuit .....	34

Revision History ..... 36

## 1. Evaluation condition

### 1.1 System configuration

Figure 1 shows the system configuration using a Sub-GHz RF LSI (R9A06G062GNP) and a front-end module. Table 1 shows the common evaluation conditions. The evaluation described in this document will be performed using a front-end module.

SAW filters are compliant with ARIB standards (920-928MHz band) and are used in both transmit and receive lines.

The firmware installed on the MCU is 'rdrv\_eva\_R9A06G062\_RX65N\_ARIB\_V104\_02976.mot'.

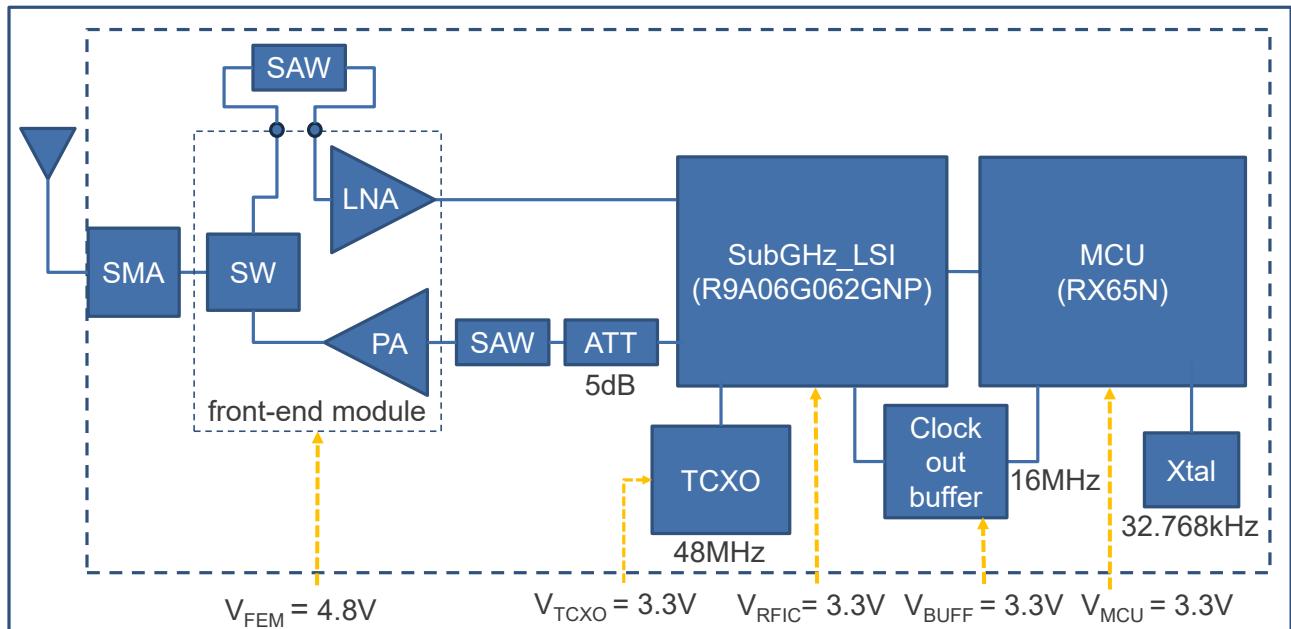

Figure 1 System Configuration

### 1.2 Temperature and supply voltage conditions

Table 1 shows the temperature and voltage settings for each part during evaluation.

Table 1 Temperature and supply voltage conditions

Item	Conditions	
Temperature	25deg C	
MCU Main clock	96MHz	
$V_{FEM}$	Voltage supplied to FEM	4.8V
$V_{TCXO}$	Voltage supplied to TCXO	3.3V
$V_{RFIC}$	Voltage supplied to R9A06G062GNP	3.3V
$V_{BUFF}$	Voltage supplied to Clock out buffer IC	3.3V
$V_{MCU}$	Voltage supplied to MCU	3.3V

### 1.3 FSK setting commands

#### 1.3.1 FSK transmission setting commands

Table 2 shows an example of FSK transmission setting commands.

**Table 2 FSK transmission setting commands example (100kbps / modulation index = 1 / 920.9MHz)**

? >rst	- Hardware reset
? >tb	- Boot mode setting (e.g. tb)
? >tope FSK JP f 2b 22	- Operation mode setting (e.g. JP band / FSK 100kbps_m=1)
? >tch 0	- Channel setting (e.g. 920.9MHz)
? >txpowd -14.5	- TX power setting (e.g. -14.5dBm@R9A06G062GNP output)
? >tfn9	- TX start (e.g. FSK TX start / PN9 signal continuous transmission)

#### 1.3.2 FSK receive setting commands

Table 3 shows an example of FSK receive setting commands.

**Table3 FSK receive setting commands example (100kbps / modulation index = 1 / 920.9MHz)**

? >rst	- Hardware reset
? >tb	- Boot mode setting (e.g. tb)
? >tope FSK JP f 2b 22	- Operation mode setting (e.g. JP band / FSK 100kbps_m=1)
? >tch 0	- Channel setting (e.g. 920.9MHz)
? >tffcs 4	- FCS length setting (e.g. FSK 4byte)
? >trxgain 120	- RF front-end gain setting (e.g. 15.0dB / LNA=16dB / RFSW+SAW=-1.0dB)
? >reg -w 0x0806 0xB8	- Initial timer setting (This setting is only required for firmware version 1.04.)
? >tfrx 0x12	- RX start (e.g. FSK RX start / PER measurement)

## 1.4 OFDM setting commands

### 1.4.1 OFDM transmission setting commands

Table 4 shows an example of OFDM transmission setting commands.

**Table 4 OFDM transmission commands example (Option3 / MCS6 / 920.9MHz)**

? >rst	- Hardware reset
? >tb	- Boot mode setting (e.g. tb)
? >tope OFDM JP op3 m6 22	- Operation mode setting (e.g. JP band / OFDM option3-MCS6)
? >tch 0	- Channel setting (e.g. 920.9MHz)
? >txpowd -13.0	- TX power setting (e.g. -13dBm@R9A06G062GNP output)
? >topn9	- TX start (e.g. FSK TX start / PN9 signal continuous transmission)

### 1.4.2 OFDM receive setting commands

Table 5 shows an example of OFDM receive setting commands.

**Table 5 OFDM receive setting commands example (Option3 / MCS6 / 920.9MHz)**

? >rst	- Hardware reset
? >tb	- Boot mode setting (e.g. tb)
? >tope OFDM JP op3 m6 22	- Operation mode setting (e.g. JP band / OFDM option3-MCS6)
? >tch 0	- Channel setting (e.g. 920.9MHz)
? >tofcs 4	- FCS length setting (e.g. OFDM 4byte)
? >trxgain 120	- RF front-end gain setting (e.g. 15.0dB / LNA=16dB / RFSW+SAW=-1.0dB)
? >reg -w 0x0806 0xB8	- Initial Timer Setting (This setting is only required for firmware version 1.04.)
? >torx 0x12	- RX start (e.g. OFDM RX start / PER measurement)

## 2. Electrical Characteristics

### 2.1 Current Characteristics

#### 2.1.1 FSK (100kbps, modulation index = 1)

Table 6 shows the current value in each mode for each power supply.

**Table 6 Current Characteristics**

Item		RF Frequency [MHz]	TX Power [dBm]	Unit	Evaluation results
TX Mode	V <sub>RFIC</sub>	924.1	+13	mA	14.2
	V <sub>FEM</sub>			mA	110.0
	V <sub>MCU</sub>			mA	20.2
RX Mode	V <sub>RFIC</sub>	924.1	-	mA	16.6
	V <sub>FEM</sub>			mA	6.1
	V <sub>MCU</sub>			mA	20.5
Idle Mode	V <sub>RFIC</sub>	924.1	-	mA	5.6
	V <sub>FEM</sub>			uA	6.6
	V <sub>MCU</sub>			mA	19.9

#### 2.1.2 OFDM (Option3, MCS6)

Table 7 shows the current value in each mode for each power supply.

**Table 7 Current Characteristics**

Item		RF Frequency [MHz]	TX Power [dBm]	Unit	Evaluation results
TX Mode	V <sub>RFIC</sub>	924.1	+13	mA	28.6
	V <sub>FEM</sub>			mA	102.4
	V <sub>MCU</sub>			mA	20.3
RX Mode	V <sub>RFIC</sub>	924.1	-	mA	22.7
	V <sub>FEM</sub>			mA	6.1
	V <sub>MCU</sub>			mA	20.5
Idle Mode	V <sub>RFIC</sub>	924.1	-	mA	5.6
	V <sub>FEM</sub>			uA	6.6
	V <sub>MCU</sub>			mA	19.9

## 2.2 TX Electrical Characteristics

### 2.2.1 FSK (100kbps, modulation index = 1)

#### (1) TX Power sweep characteristics

Signal condition: Frequency = 924.1MHz

**Table 8 TX Power sweep characteristics**

Items		Unit	Evaluation results
TX Power Range	Max	dBm	31.7
	Min		10.2
	Variable power range	dB	21.5
Current Range	V <sub>FEM</sub>	Max	803.8
		Min	89.7
	V <sub>RFIC</sub>	Max	75.0
		Min	13.8

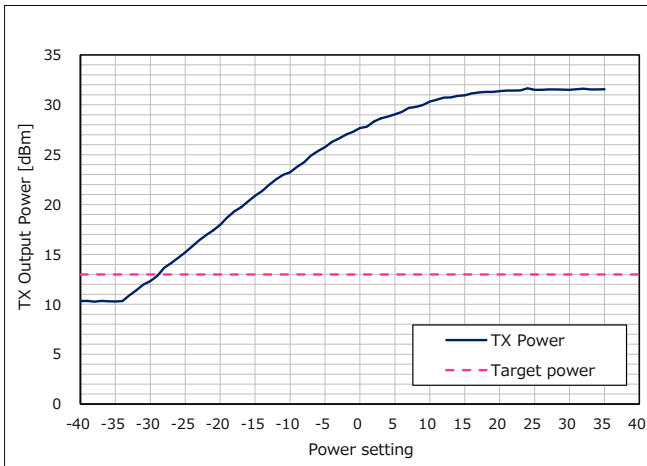

**Figure 2 Power Setting vs. TX Power (Frequency =924.1MHz)**

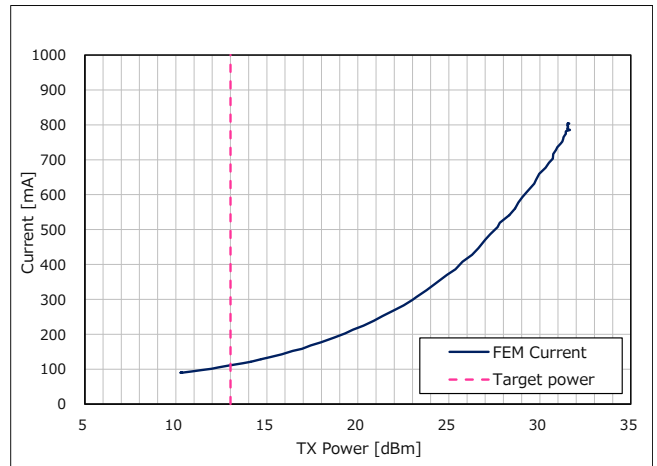

**Figure 3 TX Power vs. Current of  $V_{FEM}$  for TX mode (Frequency =924.1MHz)**

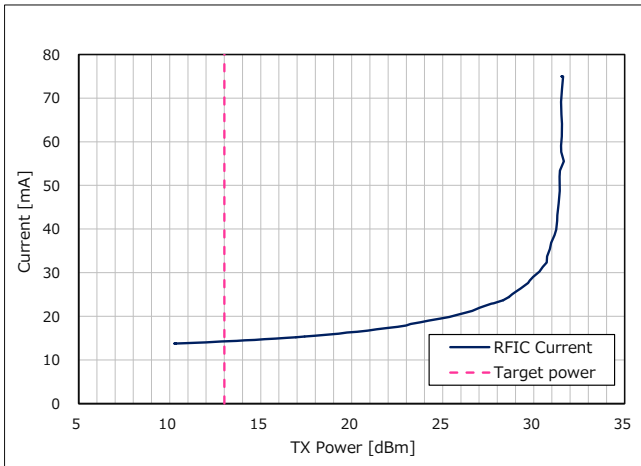

**Figure 4 TX Power vs. Current of  $V_{RFIC}$  for TX mode (Frequency =924.1MHz)**

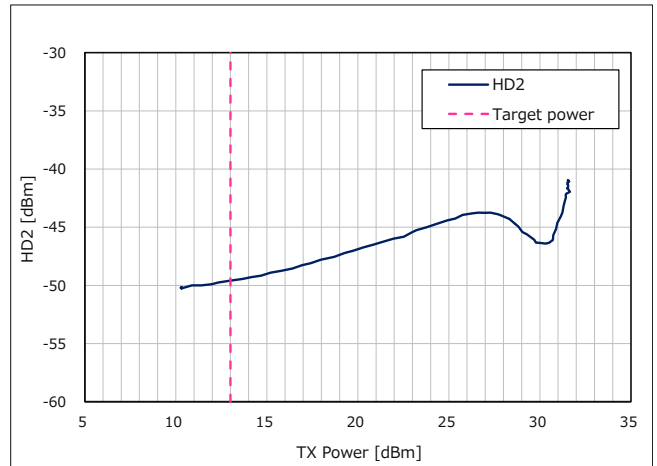

**Figure 5 TX Power vs. 2nd Harmonics (Frequency =924.1MHz)**

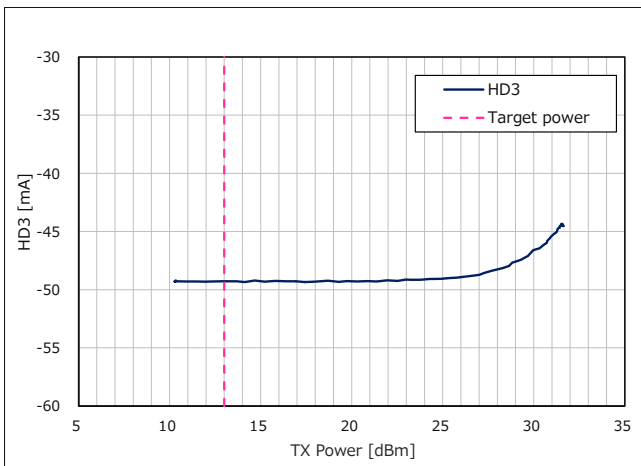

**Figure 6 TX Power vs. 3rd Harmonics (Frequency =924.1MHz)**

**(2) TX Radio Regulations characteristics**

Signal condition: Target TX Power = +13dBm

**Table 9 TX Radio Regulations characteristics (1/2)**

Item		RF Frequency [MHz]	Unit	Evaluation results	Spec
TX Power		920.9	dBm	12.2	+13.8 (*1)
		924.1		13.0	
		927.7		12.5	
Harmonics	2nd	920.9	dBm /MHz	-55.5	-30 (*1)
		924.1		-54.8	
		927.7		-55.3	
	3rd	920.9		-61.3	-30 (*1)
		924.1		-61.1	
		927.7		-61.0	
Frequency tolerance		920.9	ppm	0.7	20 (*1)
		924.1		0.7	
		927.7		0.7	
Occupied Bandwidth		920.9	kHz	181.3	200 (*1)
		924.1		181.9	
		927.7		180.5	
Adjacent Channel Power	Lower	920.9	dBm	-43.6	-15 (*1)
		924.1		-41.4	
		927.7		-42.8	
	Upper	920.9		-43.5	-15 (*1)
		924.1		-42.1	
		927.7		-43.0	
Adjacent Channel Power Ratio (M1_Lower, 300.0 kHz offset) (*2)		920.9	dBc	-58.6	-25 (*3)
		924.1		-57.4	
		927.7		-58.2	
Adjacent Channel Power Ratio (M1_Upper, 300.0 kHz offset) (*2)		920.9	dBc	-58.5	-25 (*3)
		924.1		-58.0	
		927.7		-58.4	
Adjacent Channel Power Ratio (M2_Lower, 600.0 kHz offset) (*2)		920.9	dBc	-67.2	-35 (*3)
		924.1		-66.8	
		927.7		-66.7	
Adjacent Channel Power Ratio (M2_Upper, 600.0 kHz offset) (*2)		920.9	dBc	-67.0	-35 (*3)
		924.1		-66.6	
		927.7		-67.1	
Deviation Offset		920.9	% rms	4.28	±30 (*4)
		924.1		4.20	
		927.7		4.20	
Zero Crossing Error		920.9	% pk	-1.28	±12.5 (*4)
		924.1		-1.30	
		927.7		-1.31	

(\*1) ARIB STD-T108

(\*2) IEEE.802.15.4-2020

M1:  $1.5 \cdot R \cdot (h+1)$ , M2:  $3 \cdot R \cdot (h+1)$ , R(symbol rate): 100kbps, h(modulation index): 1

(\*3) IEEE.802.15.4-2020

(\*4) Wi-SUN PHY Technical Specification - Amendment 1VA9 (11 Nov 2022).

**Table 10 TX Radio Regulations characteristics (2/2)**

Item		RF Frequency [MHz]	Unit	Evaluation results	Spec
Unwanted emissions	30 - 710MHz	920.9	dBm /100kHz	-76.4	-36 (*1)
		924.1		-76.3	
		927.7		-76.1	
	710 - 900MHz	920.9	dBm /MHz	-64.9	-55 (*1)
		924.1		-64.8	
		927.7		-65.2	
	900 - 915MHz	920.9	dBm /100kHz	-71.4	-55 (*1)
		924.1		-72.9	
		927.7		-74.1	
	915 - 930MHz	920.9	dBm /100kHz	-51.0	-36 (*1)
		924.1		-50.0	
		927.7		-50.3	
	930 - 1000MHz	920.9	dBm /100kHz	-74.0	-55 (*1)
		924.1		-71.8	
		927.7		-67.3	
	1000 - 1215MHz	920.9	dBm /MHz	-67.9	-45 (*1)
		924.1		-67.9	
		927.7		-67.9	
	1215 - 5000MHz	920.9	dBm /MHz	-59.6	-30 (*1)
		924.1		-58.9	
		927.7		-59.0	

(\*1) ARIB STD-T108

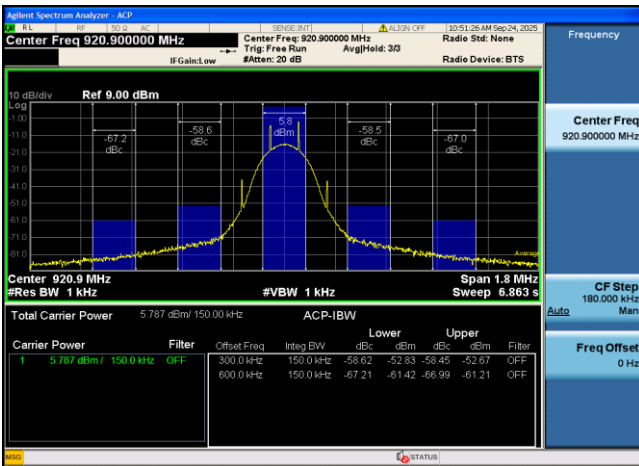

Figure 7 Transmit Spectrum (Frequency = 920.9MHz)

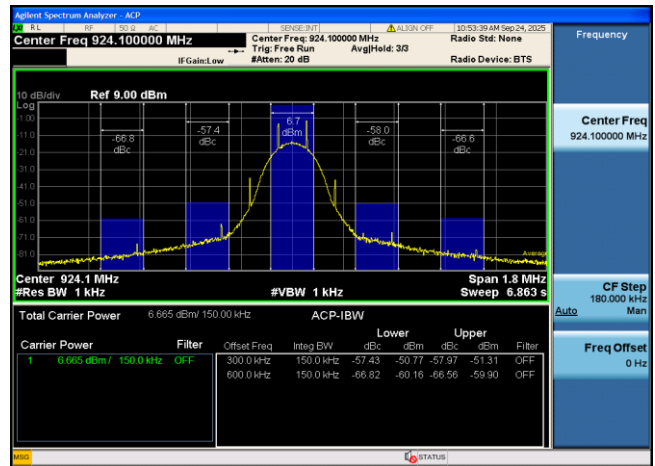

Figure 8 Transmit Spectrum (Frequency = 924.1MHz)

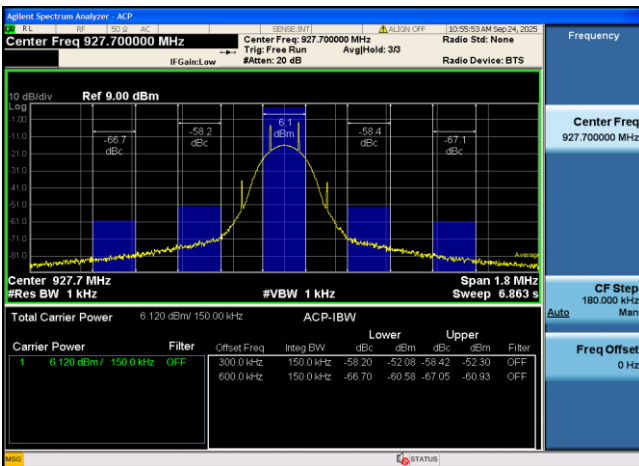

Figure 9 Transmit Spectrum (Frequency = 927.7MHz)

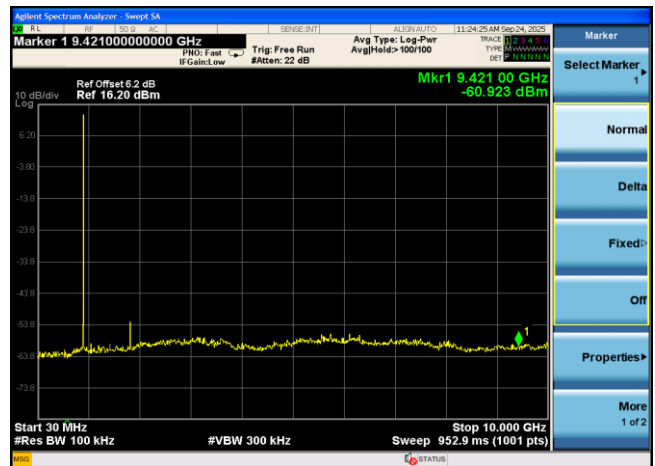

Figure 10 TX Spurious emission (Frequency = 924.1MHz)

**2.2.2 OFDM (Option3, MCS6)****(1) TX Power sweep characteristics**

Signal condition: Frequency = 924.1MHz

**Table 11 TX Power sweep characteristics**

Items		Unit	Evaluation results
TX Power Range	Max	dBm	31.1
	Min		4.8
	Variable power range	dB	26.3
Current Range	V <sub>FEM</sub>	Max	767.8
		Min	66.5
	V <sub>RFIC</sub>	Max	87.3
		Min	28.4

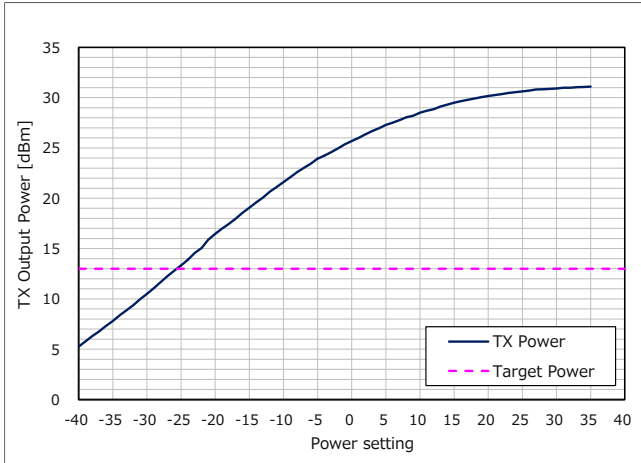

**Figure 11 Power Setting vs. TX Power (Frequency = 924.1MHz)**

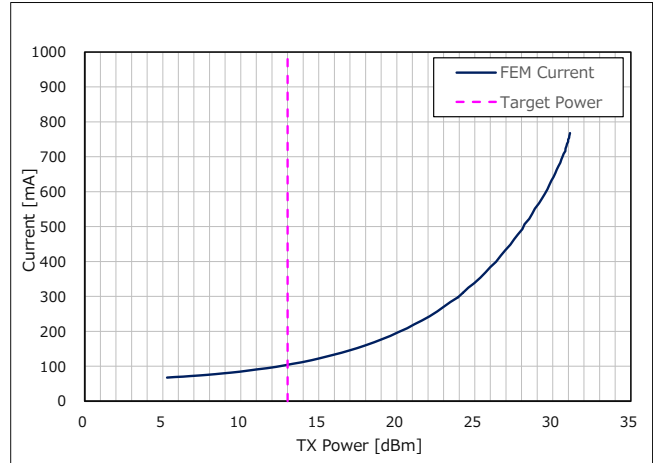

**Figure 12 TX Power vs. Current of  $V_{FEM}$  for TX mode (Frequency = 924.1MHz)**

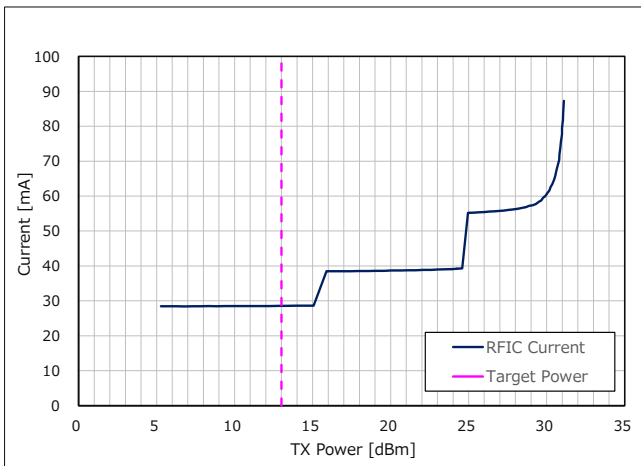

**Figure 13 TX Power vs. Current of  $V_{RFIC}$  for TX mode (Frequency = 924.1MHz)**

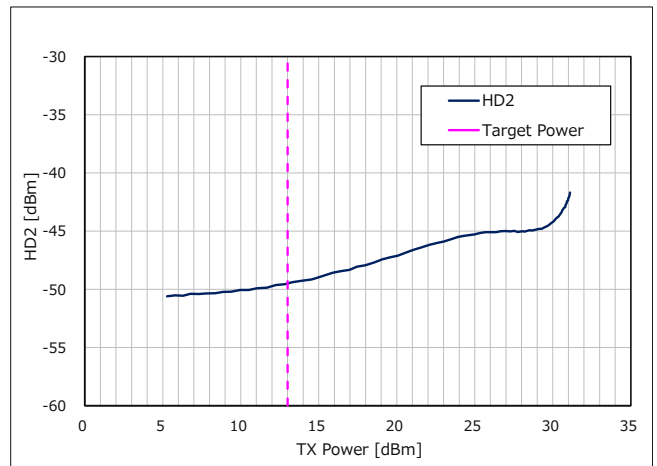

**Figure 14 TX Power vs. 2nd Harmonics (Frequency = 924.1MHz)**

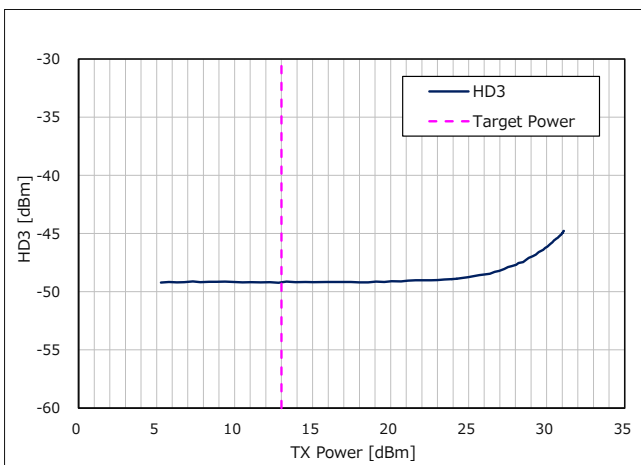

**Figure 15 TX Power vs. 3rd Harmonics (Frequency = 924.1MHz)**

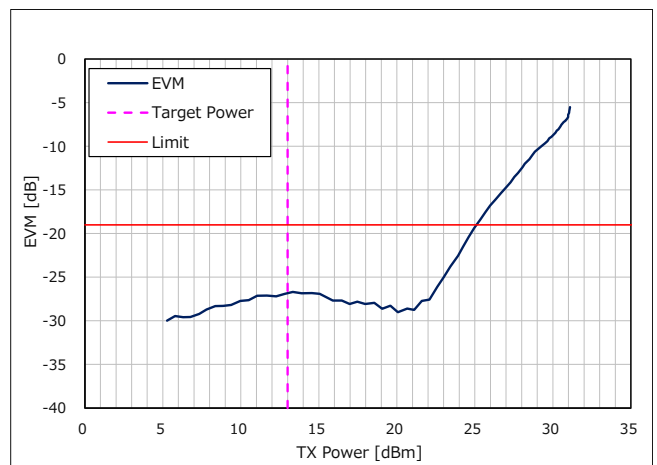

**Figure 16 TX Power vs. EVM (Frequency = 924.1MHz)**

**(2) TX Radio Regulations characteristics**

Signal condition: Target TX Power = +13dBm

**Table 12 TX Radio Regulations characteristics (1/2)**

Item		RF Frequency [MHz]	Unit	Evaluation results	Spec
TX Power		920.9	dBm	12.0	+13.8 (*1)
		924.1		12.9	
		927.7		13.0	
Harmonics	2nd	920.9	dBm /MHz	-55.2	-30 (*1)
		924.1		-54.6	
		927.7		-54.5	
	3rd	920.9		-61.0	-30 (*1)
		924.1		-60.6	
		927.7		-60.4	
Occupied Bandwidth		920.9	kHz	282.1	400 (*1)
		924.1		282.0	
		927.7		282.3	
Adjacent Channel Power	Lower	920.9	dBm	-25.9	-15 (*1)
		924.1		-25.0	
		927.7		-25.0	
	Upper	920.9	dBm	-26.5	-15 (*1)
		924.1		-26.0	
		927.7		-25.4	
Adjacent Channel Power Ratio	Lower	920.9	dBc	-37.8	-20 (*2)
		924.1		-37.9	
		927.7		-37.9	
	Upper	920.9	dBc	-38.3	
		924.1		-38.5	
		927.7		-38.2	
Alternate Channel Power Ratio	Lower	920.9	dBc	-59.0	-40 (*2)
		924.1		-59.0	
		927.7		-58.8	
	Upper	920.9	dBc	-58.8	
		924.1		-58.9	
		927.7		-59.1	
Modulation quality	EVM	920.9	dB	-26.4	-19 (*3)
		924.1		-26.7	
		927.7		-26.4	

(\*1) ARIB STD-T108

(\*2) Wi-SUN PHY Technical Specification - Amendment 1VA9 (11 Nov 2022)

(\*3) IEEE.802.15.4-2020

**Table 13 TX Radio Regulations characteristics (2/2)**

Item		RF Frequency [MHz]	Unit	Evaluation results	Spec
Unwanted emissions	30 - 710MHz	920.9	dBm /100kHz	-75.9	-36 (*1)
		924.1		-76.1	
		927.7		-76.2	
	710 - 900MHz	920.9	dBm /MHz	-64.9	-55 (*1)
		924.1		-65.0	
		927.7		-65.0	
	900 - 915MHz	920.9	dBm /100kHz	-64.6	-55 (*1)
		924.1		-65.1	
		927.7		-65.6	
	915 - 930MHz	920.9	dBm /100kHz	-40.8	-36 (*1)
		924.1		-39.3	
		927.7		-40.0	
	930 - 1000MHz	920.9	dBm /100kHz	-65.5	-55 (*1)
		924.1		-65.1	
		927.7		-63.3	
	1000 - 1215MHz	920.9	dBm /MHz	-67.9	-45 (*1)
		924.1		-67.7	
		927.7		-67.8	
	1215 - 5000MHz	920.9	dBm /MHz	-55.3	-30 (*1)
		924.1		-54.7	
		927.7		-54.6	

(\*1) ARIB STD-T108

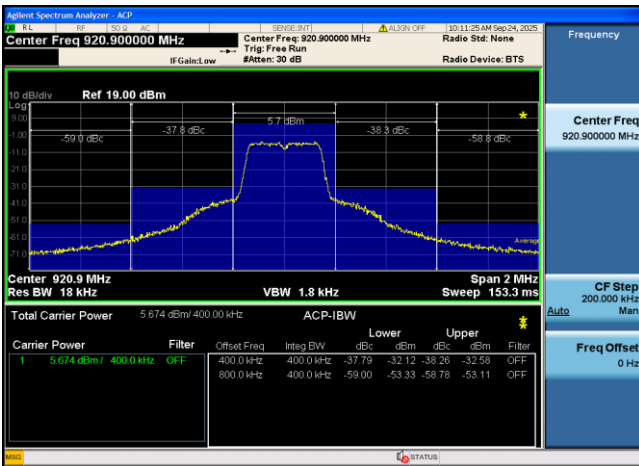

Figure 17 Transmit Spectrum (Frequency = 920.9MHz)

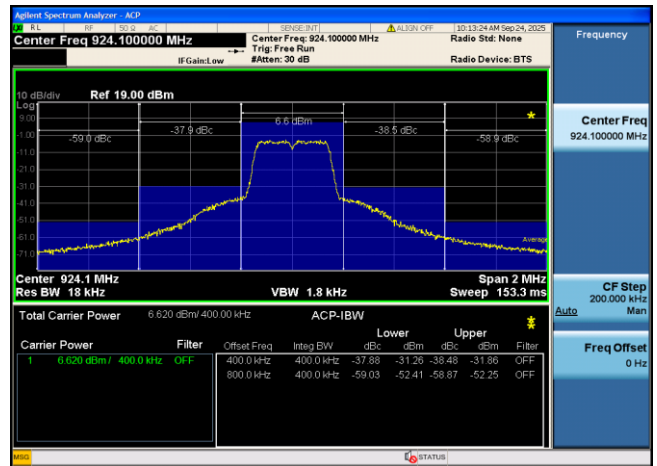

Figure 18 Transmit Spectrum (Frequency = 924.1MHz)

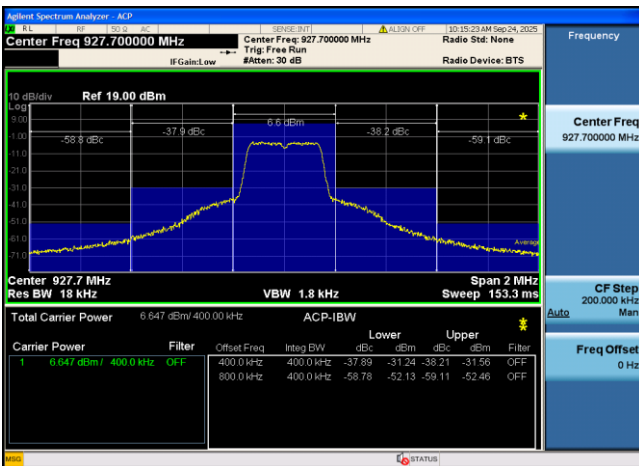

Figure 19 Transmit Spectrum (Frequency = 927.7MHz)

**2.2.3 OFDM (Option4, MCS6)****(1) TX Power sweep characteristics**

Signal condition: Frequency = 924.2MHz

**Table 14 TX Power sweep characteristics**

Items		Unit	Evaluation results
TX Power Range	Max	dBm	30.7
	Min		3.8
	Variable power range	dB	26.9
Current Range	V <sub>FEM</sub>	Max	764.9
		Min	65.2
	V <sub>RFIC</sub>	Max	88.8
		Min	27.6

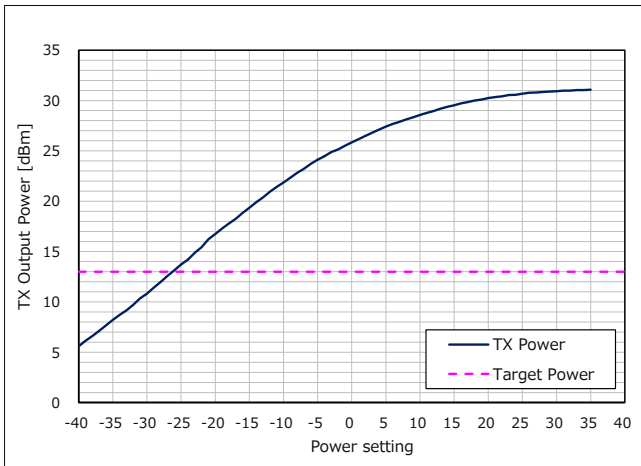

**Figure 20 Power Setting vs. TX Power (Frequency = 924.2MHz)**

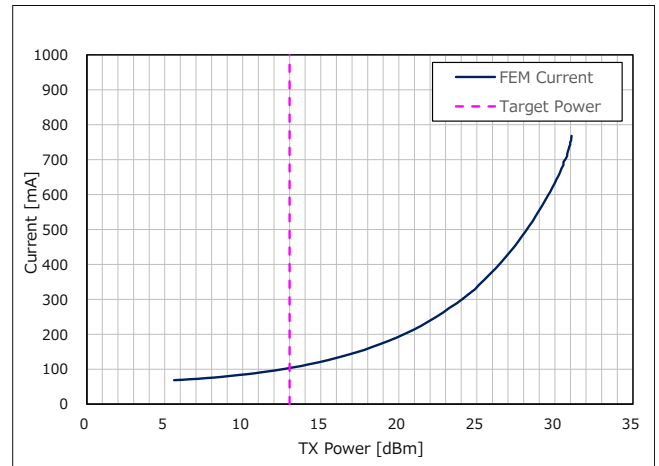

**Figure 21 TX Power vs. Current of  $V_{FEM}$  for TX mode (Frequency = 924.2MHz)**

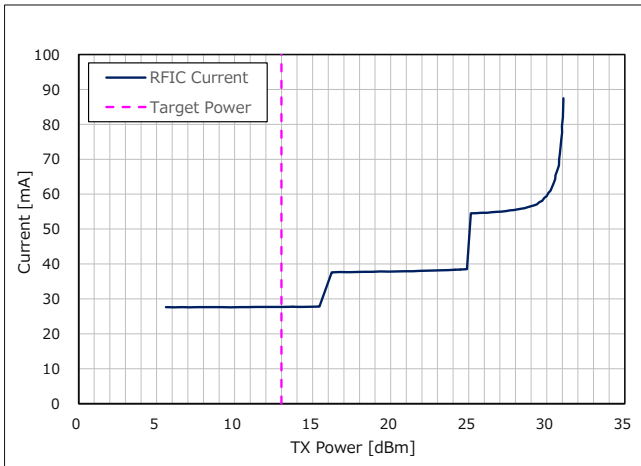

**Figure 22 TX Power vs. Current of  $V_{RFIC}$  for TX mode (Frequency = 924.2MHz)**

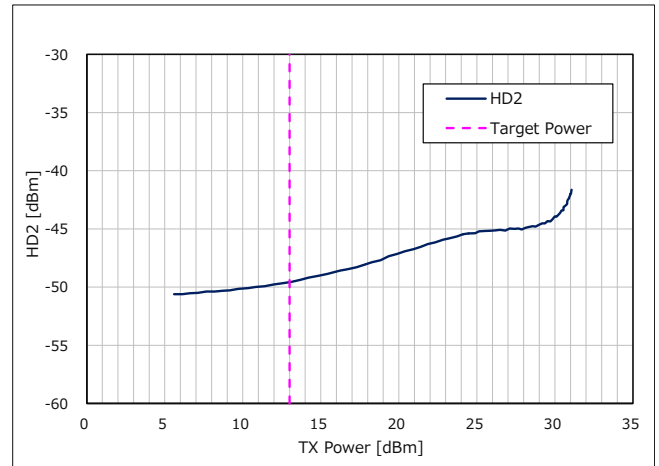

**Figure 23 TX Power vs. 2nd Harmonics (Frequency = 924.2MHz)**

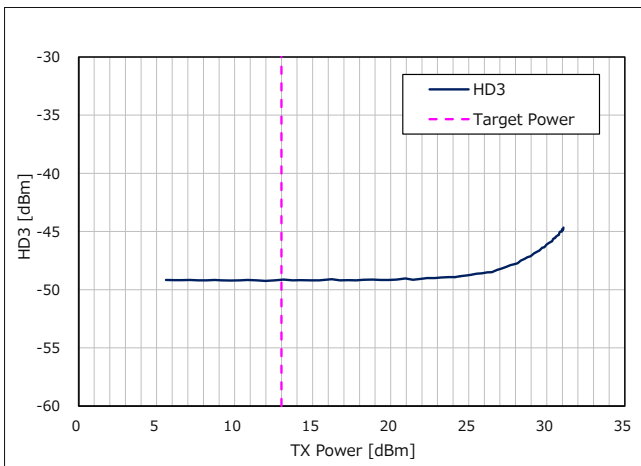

**Figure 24 TX Power vs. 3rd Harmonics (Frequency = 924.2MHz)**

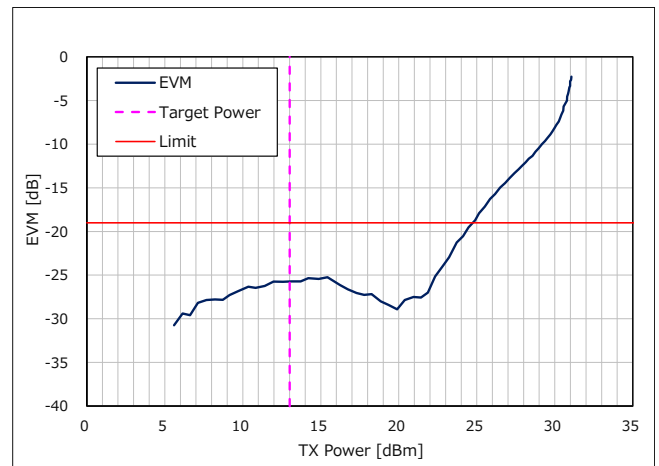

**Figure 25 TX Power vs. EVM (Frequency = 924.2MHz)**

**(2) TX Radio Regulations characteristics**

Signal condition: Target TX Power = +13dBm

**Table 15 TX Radio Regulations characteristics (1/2)**

Item		RF Frequency [MHz]	Unit	Evaluation results	Spec
TX Power		920.6	dBm	12.0	+13.8 (*1)
		924.2		13.2	
		928.0		13.0	
Harmonics	2nd	920.6	dBm /MHz	-55.3	-30 (*1)
		924.2		-54.4	
		928.0		-54.5	
	3rd	920.6		-61.0	-30 (*1)
		924.2		-60.5	
		928.0		-60.5	
Occupied Bandwidth		920.6	kHz	157.8	400 (*1)
		924.2		158.0	
		928.0		157.6	
Adjacent Channel Power	Lower	920.6	dBm	-22.6	-15 (*1)
		924.2		-21.6	
		928.0		-21.5	
	Upper	920.6	dBm	-22.5	-15 (*1)
		924.2		-21.6	
		928.0		-20.9	
Adjacent Channel Power Ratio	Lower	920.6	dBc	-34.6	-20 (*2)
		924.2		-34.5	
		928.0		-34.3	
	Upper	920.6	dBc	-34.3	
		924.2		-34.5	
		928.0		-34.2	
Alternate Channel Power Ratio	Lower	920.6	dBc	-57.1	-40 (*2)
		924.2		-56.1	
		928.0		-56.6	
	Upper	920.6	dBc	-57.0	
		924.2		-56.6	
		928.0		-57.0	
Modulation quality	EVM	920.6	dB	-25.0	-19 (*3)
		924.2		-25.4	
		928.0		-25.4	

(\*1) ARIB STD-T108

(\*2) Wi-SUN PHY Technical Specification - Amendment 1VA9 (11 Nov 2022)

(\*3) IEEE.802.15.4-2020

**Table 16 TX Radio Regulations characteristics (2/2)**

Item		RF Frequency [MHz]	Unit	Evaluation results	Spec
Unwanted emissions	30 - 710MHz	920.6	dBm /100kHz	-76.5	-36 (*1)
		924.2		-76.3	
		928.0		-76.1	
	710 - 900MHz	920.6	dBm /MHz	-64.9	-55 (*1)
		924.2		-64.7	
		928.0		-64.8	
	900 - 915MHz	920.6	dBm /100kHz	-65.0	-55 (*1)
		924.2		-65.2	
		928.0		-65.5	
	915 - 930MHz	920.6	dBm /100kHz	-44.7	-36 (*1)
		924.2		-43.4	
		928.0		-43.4	
	930 - 1000MHz	920.6	dBm /100kHz	-65.4	-55 (*1)
		924.2		-64.6	
		928.0		-63.0	
	1000 - 1215MHz	920.6	dBm /MHz	-67.9	-45 (*1)
		924.2		-67.7	
		928.0		-67.8	
	1215 - 5000MHz	920.6	dBm /MHz	-55.4	-30 (*1)
		924.2		-54.9	
		928.0		-54.8	

(\*1) ARIB STD-T108

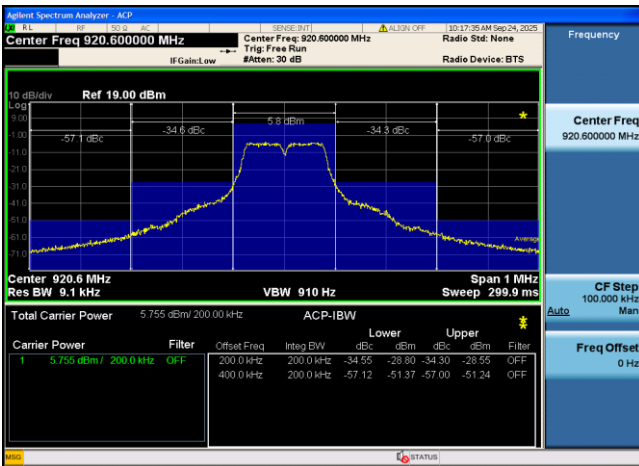

Figure 26 Transmit Spectrum (Frequency = 920.6MHz)

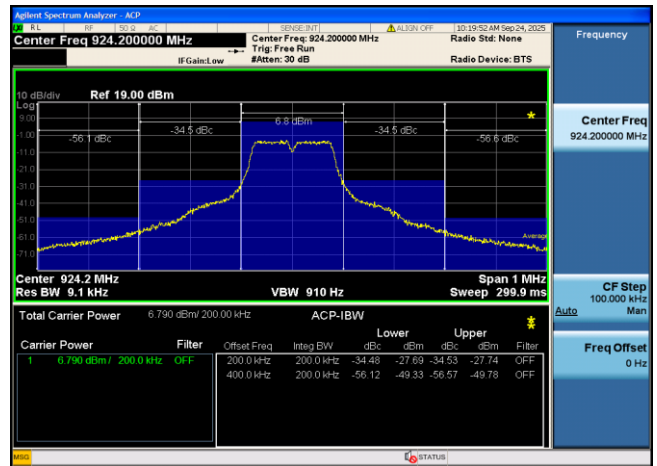

Figure 27 Transmit Spectrum (Frequency = 924.2MHz)

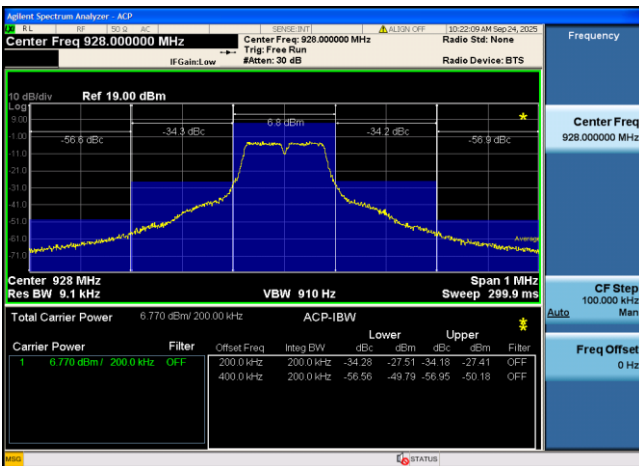

Figure 28 Transmit Spectrum (Frequency = 928.0MHz)

## 2.3 RX Electrical Characteristics

### 2.3.1 FSK (100kbps, modulation index = 1)

Table 17 RX Electrical Characteristics (1/2)

Items			RF Frequency [MHz]	Unit	Evaluation result	Spec
Receiver sensitivity	PER < 10% Length 250 octets		920.9	dBm	-106	-88 (*4)
			924.1		-106	
			927.7		-106	
Maximum Input level	PER < 10% Length 250 octets		920.9	dBm	10	≥ -20 (*4)
			924.1		10	
			927.7		10	
RSSI accuracy	Average	RSSI range: -106dBm to -20dBm (*1)	920.9	dB	-1.0	-
			924.1		1.0	
			927.7		-1.5	
	MAX		920.9		0.5	
			924.1		1.0	
			927.7		-1.5	
	MIN		920.9		-1.0	
			924.1		-1.0	
			927.7		-1.5	
ED accuracy	Average	ED range: -106dBm to -20dBm (*1)	924.1	dB	2.1	-
	MAX		924.1		2.5	
	MIN		924.1		2.0	
Frequency tolerance	Max	PER < 10% Length 250 octets	924.1	ppm	≥ 100	±20
	Min				≤ -100	
Adjacent channel rejection	-400kHz	PER < 10% (*2) (*3) Length 250 octets	924.1	dB	48	10 (*4)
	+400kHz				48	
Alternate channel rejection	-800kHz	PER < 10% (*2) (*3) Length 250 octets	924.1	dB	58	30 (*4)
	+800kHz				58	
Co channel rejection	±0MHz	PER < 10% (*2) (*3) Length 250 octets	924.1	dB	-5	-
Blocking	+1MHz	PER < 10% (*2) (*3) Length 250 octets	924.1	dB	60	-
	-2MHz				50	
	+2MHz				51	
	-10MHz				69	
	+10MHz				69	
Image rejection	-1.5MHz	PER < 10% (*2) (*3) Length 250 octets	924.1	dB	35	-

(\*1) Lower limit: RX sensitivity / Upper limit: Limit described in the user's manual (-5dBm) - FEM LNA gain (16dB) + SAW Filter Loss (1dB).

(\*2) The level of the desired signal: RX sensitivity + 3dB (-103dBm)

(\*3) Interference signal is non-modulated wave.

(\*4) IEEE.802.15.4-2020.

**Table 18 RX Electrical Characteristics (2/2)**

Item		RF Frequency [MHz]	Unit	Evaluation results	Spec
Receiver spurious emission (*1)	30 - 710MHz	920.9	dBm /100kHz	-98.0	-54 (*2)
		924.1		-97.8	
		927.7		-97.9	
	710 - 900MHz	920.9	dBm /MHz	-88.4	-55 (*2)
		924.1		-88.1	
		927.7		-88.3	
	900 - 915MHz	920.9	dBm /100kHz	-98.5	-55 (*2)
		924.1		-98.7	
		927.7		-98.5	
	915 - 930MHz	920.9	dBm /100kHz	-98.3	-54 (*2)
		924.1		-98.5	
		927.7		-98.4	
	930 - 1000MHz	920.9	dBm /100kHz	-98.9	-55 (*2)
		924.1		-98.7	
		927.7		-98.9	
	1000 - 5000MHz	920.9	dBm /MHz	-83.3	-47 (*2)
		924.1		-82.8	
		927.7		-83.2	

(\*1) Corresponds to "Limit on Secondary Radiated Emissions." specified by ARIB STD-T108.

(\*2) ARIB STD-T108

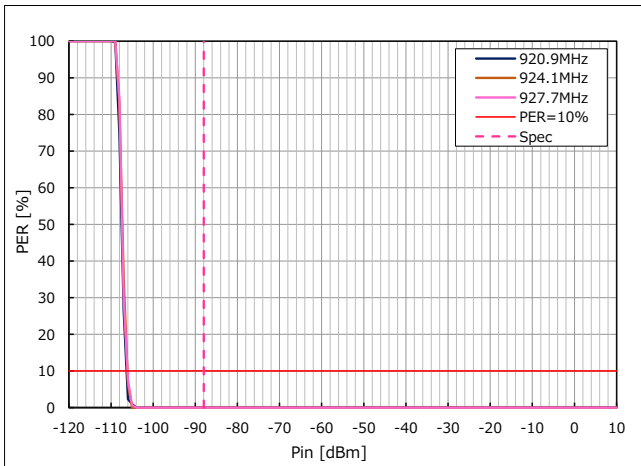

**Figure 29 RF Input Level vs. Packet Error Rate**  
(Frequency = 920.9 / 924.1 / 927.7MHz)

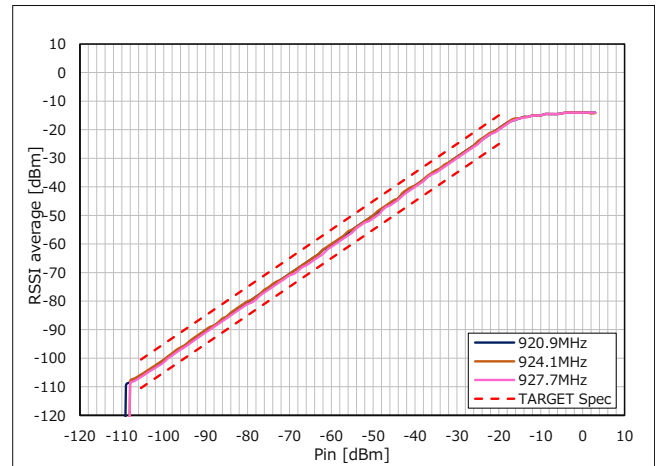

**Figure 30 RF Input Level vs. RSSI average**  
(Frequency = 920.9 / 924.1 / 927.7MHz)

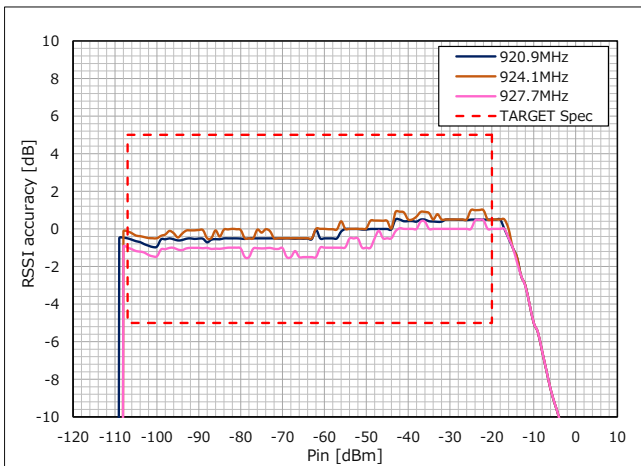

**Figure 31 RF Input Level vs. RSSI accuracy**  
(Frequency = 920.9 / 924.1 / 927.7MHz)

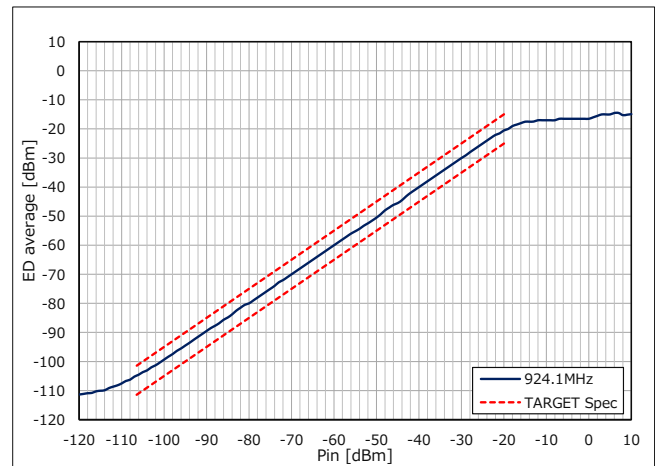

**Figure 32 RF Input Level vs. ED average**  
(Frequency = 924.1MHz)

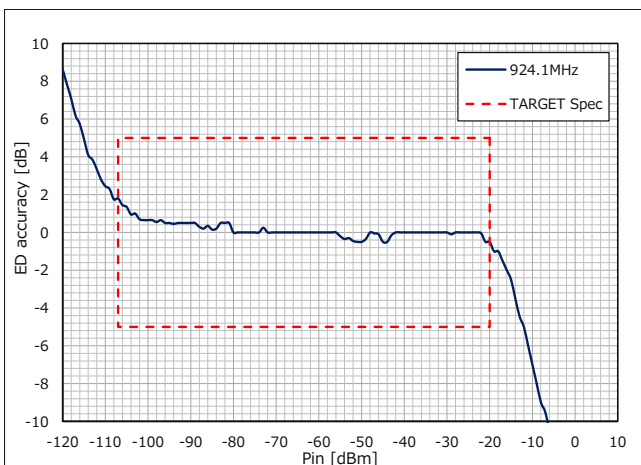

**Figure 33 RF Input Level vs. ED accuracy**  
(Frequency = 924.1MHz)

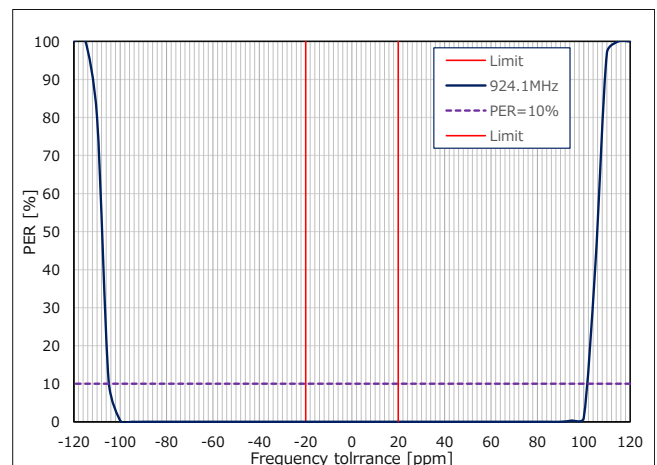

**Figure 34 RF Frequency tolerance vs. Packet Error Rate**  
(Frequency = 924.1MHz)

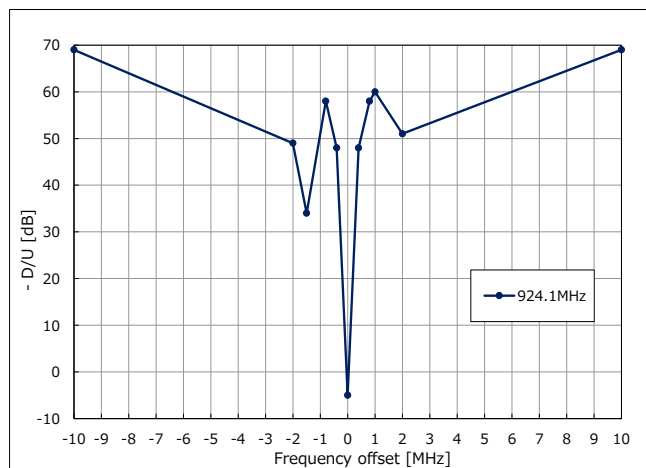

**Figure 35 RF Frequency offset vs. Desire/Unwanted Signal Ratio (Frequency = 924.1MHz)**

## 2.3.2 OFDM (Option3, MCS6)

Table 19 RX Electrical Characteristics (1/2)

Items			RF Frequency [MHz]	Unit	Evaluation result	Spec
Receiver sensitivity	PER < 10% Length 250 octets		920.9	dBm	-102	-91 (*6)
			924.1		-103	
			927.7		-103	
Maximum Input level	PER < 10% Length 250 octets		920.9	dBm	-14	≥ -20 (*6)
			924.1		-14	
			927.7		-14	
RSSI accuracy	Average	RSSI range: -103dBm to -20dBm (*1)	920.9	dB	1.0	-
			924.1		2.0	
			927.7		1.0	
	MAX		920.9		1.0	
			924.1		2.0	
			927.7		1.0	
	MIN		920.9		1.0	
			924.1		1.5	
			927.7		1.0	
ED accuracy	Average	ED range: -103dBm to -20dBm (*1)	924.1	dB	1.1	-
	MAX		924.1		1.5	
	MIN		924.1		1.0	
Frequency tolerance	Max	PER < 10% Length 250 octets	924.1	ppm	≥ 50	±20
	Min				≤ -50	
Adjacent channel rejection	-400kHz	PER < 10% (*2) (*3) (*5) Length 250 octets	924.1	dB	37	2 (*7)
	+400kHz				36	
Alternate channel rejection	-800kHz	PER < 10% (*2) (*3) (*5) Length 250 octets	924.1	dB	49	26 (*7)
	+800kHz				50	
Co channel rejection	±0MHz	PER < 10% (*2) (*4) (*5) Length 250 octets	924.1	dB	-13	-23 (*7)
Blocking	+1MHz	PER < 10% (*2) (*3) (*5) Length 250 octets	924.1	dB	50	-
	-2MHz				50	
	+2MHz				50	
	-10MHz				51	
	+10MHz				52	
Image rejection	-1.5MHz	PER < 10% (*2) (*3) (*5) Length 250 octets	924.1	dB	17	-

(\*1) Lower limit: RX sensitivity / Upper limit: Limit described in the user's manual (-5dBm) - FEM LNA gain (16dB) + SAW Filter Loss (1dB).

(\*2) The level of the desired signal: RX sensitivity + 3dB (-100dBm)

(\*3) Interference signal pattern defined by the certification body.

(\*4) Interference signal pattern without LTF and STF defined by Wi-SUN.

(\*5) Interference signal is modulated wave.

(\*6) IEEE.802.15.4-2020.

(\*7) Wi-SUN PHY Technical Specification - Amendment 1VA9 (11 Nov 2022)

**Table 20 RX Electrical Characteristics (2/2)**

Item		RF Frequency [MHz]	Unit	Evaluation results	Spec
Receiver spurious emission (*1)	30 - 710MHz	920.9	dBm /100kHz	-97.9	-54 (*2)
		924.1		-98.1	
		927.7		-98.1	
	710 - 900MHz	920.9	dBm /MHz	-88.5	-55 (*2)
		924.1		-88.5	
		927.7		-88.6	
	900 - 915MHz	920.9	dBm /100kHz	-98.7	-55 (*2)
		924.1		-98.2	
		927.7		-98.6	
	915 - 930MHz	920.9	dBm /100kHz	-98.5	-54 (*2)
		924.1		-98.5	
		927.7		-98.5	
	930 - 1000MHz	920.9	dBm /100kHz	-98.6	-55 (*2)
		924.1		-98.6	
		927.7		-98.5	
	1000 - 5000MHz	920.9	dBm /MHz	-83.4	-47 (*2)
		924.1		-83.2	
		927.7		-83.4	

(\*1) Corresponds to "Limit on Secondary Radiated Emissions." specified by ARIB STD-T108.

(\*2) ARIB STD-T108

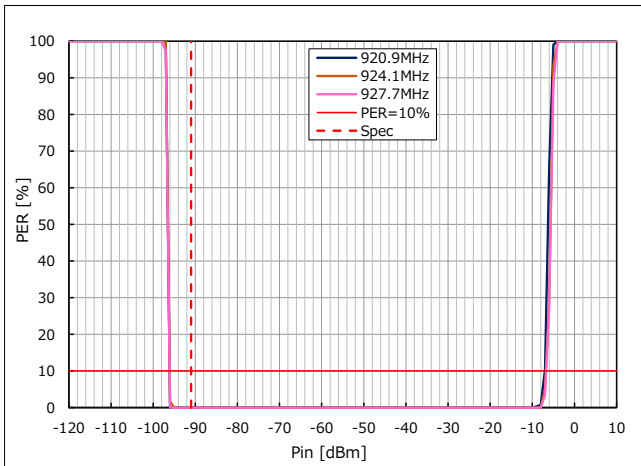

**Figure 36 RF Input Level vs. Packet Error Rate (Frequency = 920.9 / 924.1 / 927.7MHz)**

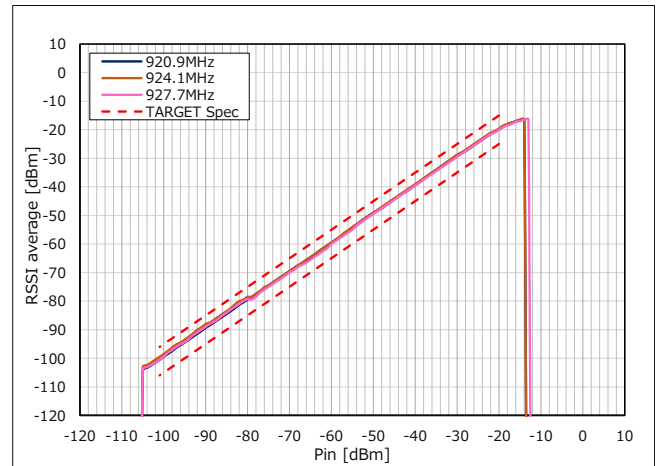

**Figure 37 RF Input Level vs. RSSI average (Frequency = 920.9 / 924.1 / 927.7MHz)**

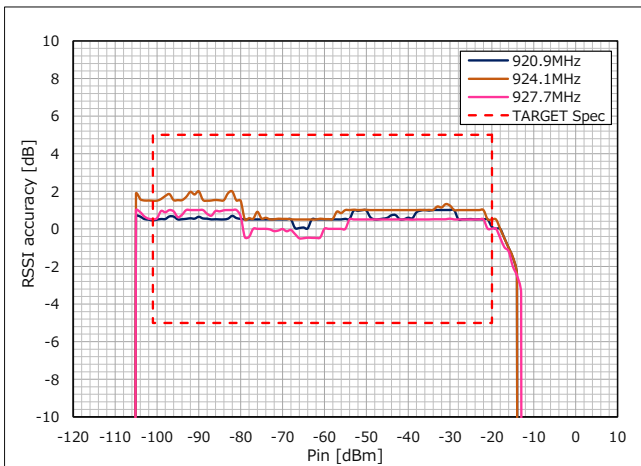

**Figure 38 RF Input Level vs. RSSI accuracy (Frequency = 920.9 / 924.1 / 927.7MHz)**

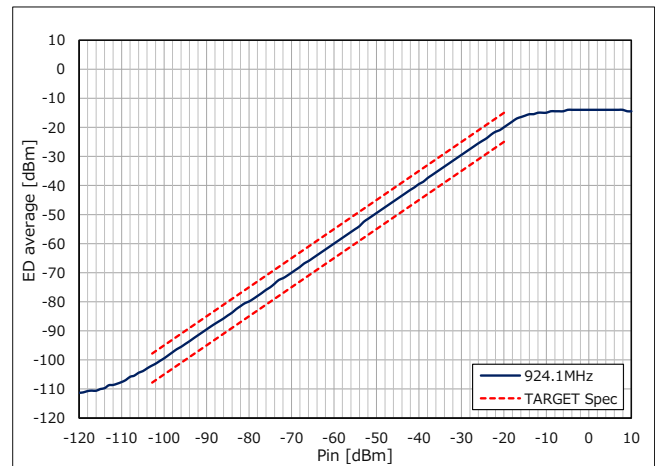

**Figure 39 RF Input Level vs. ED average (Frequency = 924.1MHz)**

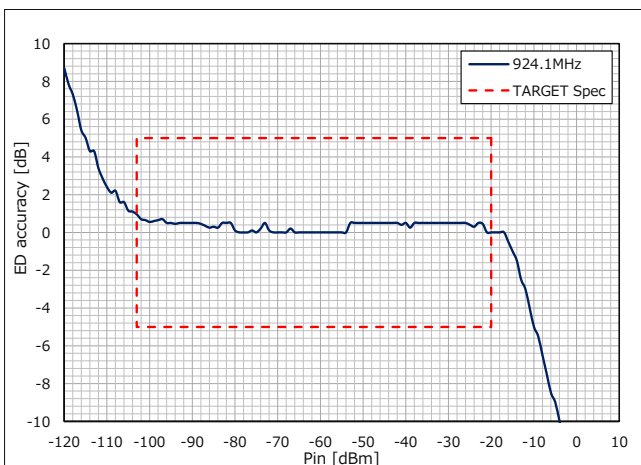

**Figure 40 RF Input Level vs. ED accuracy (Frequency = 924.1MHz)**

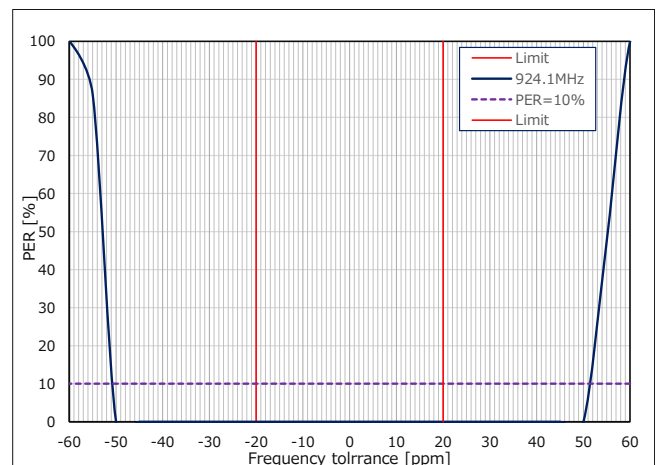

**Figure 41 RF Frequency tolerance vs. Packet Error Rate (Frequency = 924.1MHz)**

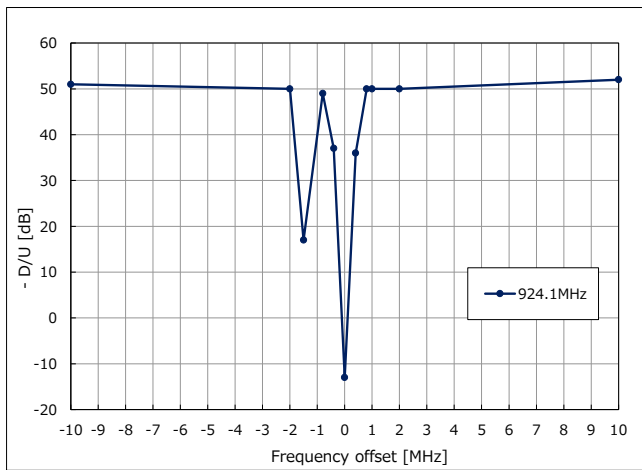

**Figure 42 RF Frequency offset vs. Desire/Unwanted Signal Ratio (Frequency = 924.1MHz)**

## 2.3.3 OFDM (Option4, MCS6)

Table 21 RX Electrical Characteristics (1/2)

Items		RF Frequency [MHz]	Unit	Evaluation result	Spec		
Receiver sensitivity	PER < 10% Length 250 octets	920.6	dBm	-105	-94 (*6)		
		924.2		-106			
		928.0		-106			
Maximum Input level	PER < 10% Length 250 octets	920.6	dBm	-15	≥ -20 (*6)		
		924.2		-15			
		928.0		-14			
RSSI accuracy	Average	RSSI range: -106dBm to -20dBm (*1)	dB	920.6	1.0	-	
				924.2	2.0		
				928.0	1.0		
	MAX			920.6	1.5		
				924.2	2.0		
				928.0	1.5		
	MIN			920.6	1.0		
				924.2	2.0		
				928.0	1.0		
ED accuracy	Average	ED range: -106dBm to -20dBm (*1)	dB	924.2	1.0	-	
				MAX	924.2		1.5
				MIN	924.2		0.5
Frequency tolerance	Max	PER < 10% Length 250 octets	924.2	ppm	≥ 40	±20	
	Min				≤ -40		
Adjacent channel rejection	-200kHz	PER < 10% (*2) (*3) (*5) Length 250 octets	924.2	dB	27	2 (*7)	
	+200kHz				26		
Alternate channel rejection	-400kHz	PER < 10% (*2) (*3) (*5) Length 250 octets	924.2	dB	45	26 (*7)	
	+400kHz				46		
Co channel rejection	±0MHz	PER < 10% (*2) (*4) (*5) Length 250 octets	924.2	dB	-13	-23 (*7)	
Blocking	+1MHz	PER < 10% (*2) (*3) (*5) Length 250 octets	924.2	dB	53	-	
	-2MHz				53		
	+2MHz				53		
	-10MHz				54		
	+10MHz				55		
Image rejection	-1.1MHz	PER < 10% (*2) (*3) (*5) Length 250 octets	924.2	dB	20	-	

(\*1) Lower limit: RX sensitivity / Upper limit: Limit described in the user's manual (-5dBm) - FEM LNA gain (16dB) + SAW Filter Loss (1dB).

(\*2) The level of the desired signal: RX sensitivity + 3dB (-103dBm)

(\*3) Interference signal pattern defined by the certification body.

(\*4) Interference signal pattern without LTF and STF defined by Wi-SUN.

(\*5) Interference signal is modulated wave.

(\*6) IEEE.802.15.4-2020.

(\*7) Wi-SUN PHY Technical Specification - Amendment 1VA9 (11 Nov 2022)

**Table 22 RX Electrical Characteristics (2/2)**

Item		RF Frequency [MHz]	Unit	Evaluation results	Spec
Receiver spurious emission (*1)	30 - 710MHz	920.6	dBm /100kHz	-98.0	-54 (*2)
		924.2		-97.9	
		928.0		-98.3	
	710 - 900MHz	920.6	dBm /MHz	-88.6	-55 (*2)
		924.2		-88.1	
		928.0		-88.6	
	900 - 915MHz	920.6	dBm /100kHz	-98.5	-55 (*2)
		924.2		-98.2	
		928.0		-98.7	
	915 - 930MHz	920.6	dBm /100kHz	-98.8	-54 (*2)
		924.2		-98.5	
		928.0		-98.7	
	930 - 1000MHz	920.6	dBm /100kHz	-98.9	-55 (*2)
		924.2		-98.7	
		928.0		-98.6	
	1000 - 5000MHz	920.6	dBm /MHz	-83.1	-47 (*2)
		924.2		-83.8	
		928.0		-83.4	

(\*1) Corresponds to "Limit on Secondary Radiated Emissions." specified by ARIB STD-T108.

(\*2) ARIB STD-T108

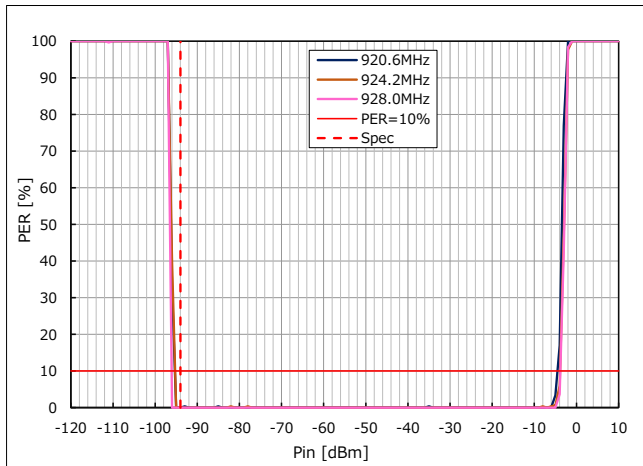

**Figure 43 RF Input Level vs. Packet Error Rate (Frequency = 920.6 / 924.2 / 928.0MHz)**

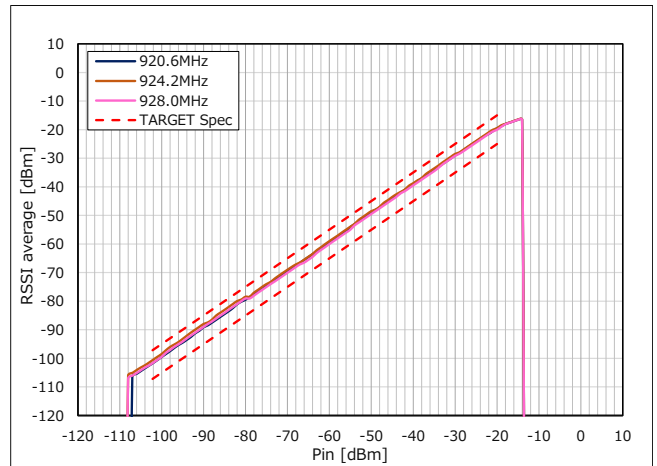

**Figure 44 RF Input Level vs. RSSI average (Frequency = 920.6 / 924.2 / 928.0MHz)**

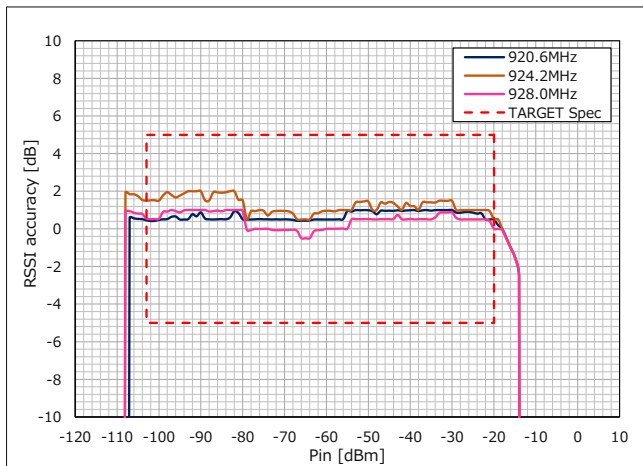

**Figure 45 RF Input Level vs. RSSI accuracy (Frequency = 920.6 / 924.2 / 928.0MHz)**

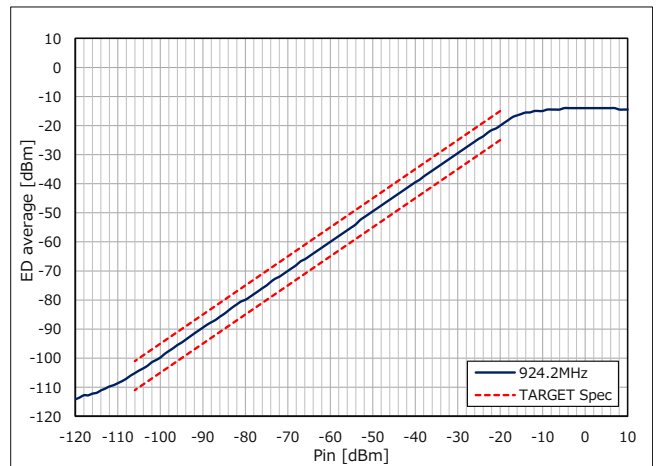

**Figure 46 RF Input Level vs. ED average (Frequency = 924.2MHz)**

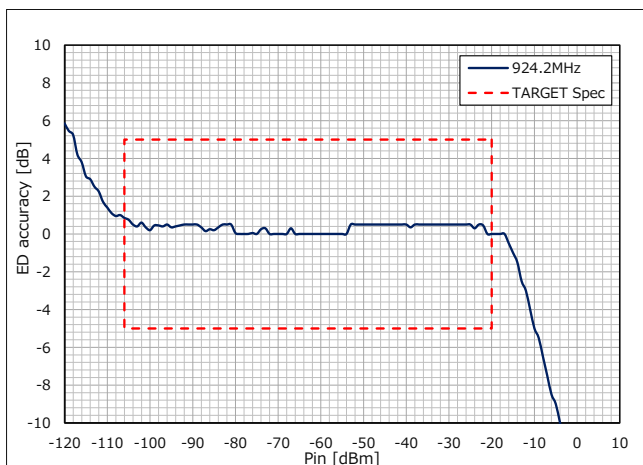

**Figure 47 RF Input Level vs. ED accuracy (Frequency = 924.2MHz)**

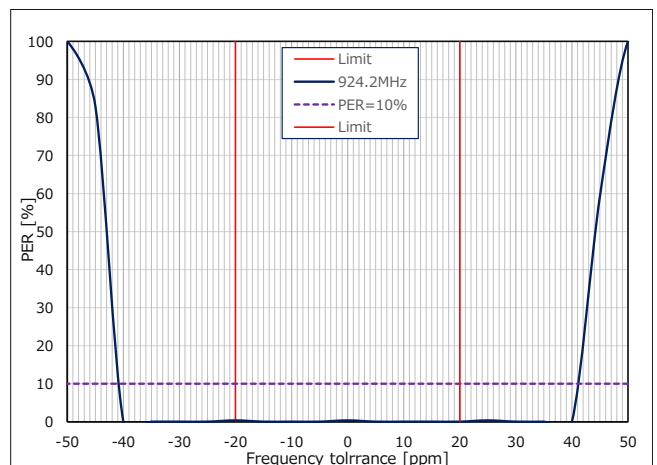

**Figure 48 RF Frequency tolerance vs. Packet Error Rate (Frequency = 924.2MHz)**

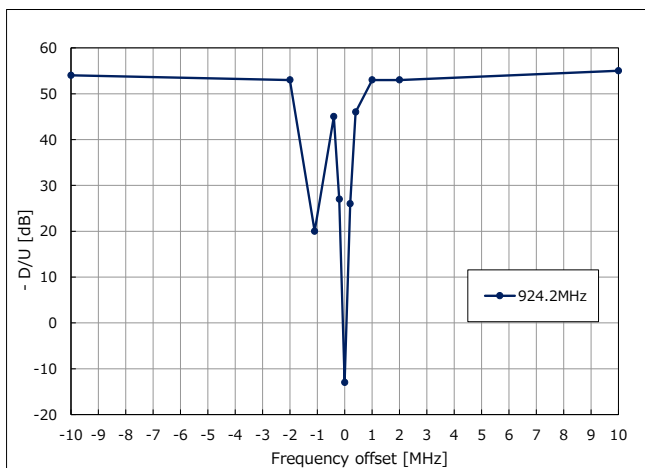

**Figure 49 RF Frequency offset vs. Desire/Unwanted Signal Ratio (Frequency = 924.2MHz)**

### 3. Example of Peripheral Circuit

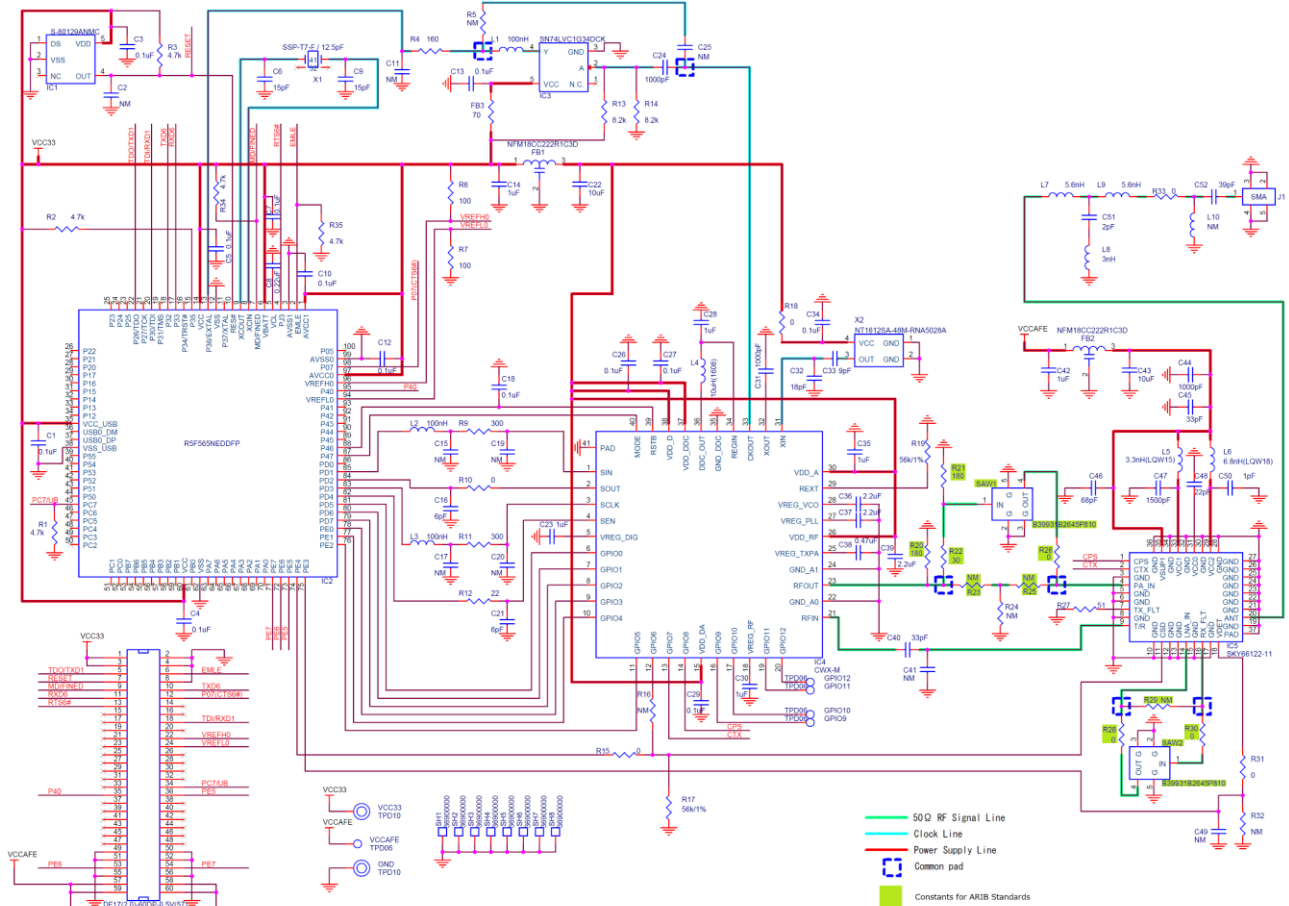

Figure 50 Example of Peripheral Circuit

Table 23 BOM Lists

Part	Description	Parts number	Part	Description	Parts number
CN1	60-pin board connector	DF17(2.0)-60DP-0.5V(57)	L2,L3,L1	100nH	LQP03TNR10H02D
C1,C3,C4,C5,C7,C10,C12,C13,C18,C26,C27,C29,C34	0.1uF	GRM033R61C104KE84D	L4	10uH(1608)	MLZ1608M100WT
C2,C11,C15,C17,C19,C20,C25,C41,C49	Not mounted		L5	3.3nH(LQW15)	LQW15AN3N3C80
C6,C9	15pF	GRM0332C1H150JA01D	L6	6.8nH(LQW18)	LQW18AN6N8C00
C8	0.22uF	GRM033R61A224KE90D	L7,L9	5.6nH	LQG15HS5N6B02D
C14,C23,C28,C30,C35,C42	1uF	CL03A105KP3NSNC	L8	3nH	LQG15HS3N0B02D
C16,C21	6pF	GRM0335C1H6R0BA01D	L10	Not mounted	
C22,C43	10uF	GRM155R61A106ME11D	R1,R2,R3,R34,R35,	4.7k ohm	RK73B1HTTC472J
C24,C31,C44	1000pF	GRM033R71H102KA12D	R6,R7,	100 ohm	RK73B1HTTC101J
C32	18pF	GRM0332C1H180JA01D	R5,R16,R23,R24,R25,R29,R32	Not mounted	
C33	9pF	GRM0335C1H9R0BA01D	R10,R15,R18,R26,R28,R30,	0 ohm	RK73Z1HTTC
C36,C37,C39	2.2uF	GRM033R61A225KE47D	R31		
C38	0.47uF	LMK063BBJ474KPLF	R9,R11	300 ohm	RK73B1HTTC301J
C40,C45	33pF	GRM0332C1H330JA01D	R13,R14	8.2k ohm	RK73B1HTTC822J
C46	68pF	GRM0332C1H680JA01D	R17,R19	56k ohm/1%	RK73H1HTTC5602F
C47	1500pF	GRM033R71H152KA12D	R4	160 ohm	RK73B1HTTC161J
C48	22pF	GRM0332C1H220JA01D	R12	22 ohm	RK73B1HTTC220J
C50	1pF	GRM0335C1H1R0BA01D	R20,R21	180 ohm	RK73B1HTTC181J
C51	2pF	GRM1555C1H2R0BA01D	R22	30 ohm	RK73B1HTTC300J
C52	39pF	CL05C390JB5NNNC	R27	51 ohm	RK73B1HTTC510J
FB1,FB2	EMI Filter 2200pF/DC16V	NFM18CC22R1C3D	R33	0 ohm	RK73Z1ETTP
FB3	Ferrite Bead 70 ohm	BLM03AG700SN1	SAW1,SAW2	SAW Filter for ARIB	B39931B2645P810
IC1	Reset IC	S-80129ANMC-JCOxU	X1	CRYSTAL 32.7680KHz	SSP-T7-F / 12.5pF
IC2	RX65N	R5F565NEDDFP	X2	TCXO 48MHz	NT1612SA-48M-RNA5028A
IC3	Clock Buffer IC	SN74LVC1G34DCK	SH1,SH2,SH3,SH4,SH5,SH6,	Shielding Cabinet Clip	36900000
IC4	CWX-M	R9A06G062GNP	SH7,SH8		
IC5	front-end-module	SKY66122-11	VCC33,GND	Pin header vias	TPD10
J1	SMA Connector	73251-1150	GPIO9,GPIO10,GPIO11,	Pin header vias	TPD06
			GPIO12,VCCAFE		

Green text: Applicable to ARIB standards

**Revision History**

Rev.	Date	Description	
		Page	Summary
1.00	Nov.15.2025	-	First edition issued

## General Precautions in the Handling of Microprocessing Unit and Microcontroller Unit Products

The following usage notes are applicable to all Microprocessing unit and Microcontroller unit products from Renesas. For detailed usage notes on the products covered by this document, refer to the relevant sections of the document as well as any technical updates that have been issued for the products.

### 1. Precaution against Electrostatic Discharge (ESD)

A strong electrical field, when exposed to a CMOS device, can cause destruction of the gate oxide and ultimately degrade the device operation. Steps must be taken to stop the generation of static electricity as much as possible, and quickly dissipate it when it occurs. Environmental control must be adequate. When it is dry, a humidifier should be used. This is recommended to avoid using insulators that can easily build up static electricity.

Semiconductor devices must be stored and transported in an anti-static container, static shielding bag or conductive material. All test and measurement tools including work benches and floors must be grounded. The operator must also be grounded using a wrist strap. Semiconductor devices must not be touched with bare hands. Similar precautions must be taken for printed circuit boards with mounted semiconductor devices.

### 2. Processing at power-on

The state of the product is undefined at the time when power is supplied. The states of internal circuits in the LSI are indeterminate and the states of register settings and pins are undefined at the time when power is supplied. In a finished product where the reset signal is applied to the external reset pin, the states of pins are not guaranteed from the time when power is supplied until the reset process is completed. In a similar way, the states of pins in a product that is reset by an on-chip power-on reset function are not guaranteed from the time when power is supplied until the power reaches the level at which resetting is specified.

### 3. Input of signal during power-off state

Do not input signals or an I/O pull-up power supply while the device is powered off. The current injection that results from input of such a signal or I/O pull-up power supply may cause malfunction and the abnormal current that passes in the device at this time may cause degradation of internal elements. Follow the guideline for input signal during power-off state as described in your product documentation.

### 4. Handling of unused pins

Handle unused pins in accordance with the directions given under handling of unused pins in the manual. The input pins of CMOS products are generally in the high-impedance state. In operation with an unused pin in the open-circuit state, extra electromagnetic noise is induced in the vicinity of the LSI, an associated shoot-through current flows internally, and malfunctions occur due to the false recognition of the pin state as an input signal become possible.

### 5. Clock signals

After applying a reset, only release the reset line after the operating clock signal becomes stable. When switching the clock signal during program execution, wait until the target clock signal is stabilized. When the clock signal is generated with an external resonator or from an external oscillator during a reset, ensure that the reset line is only released after full stabilization of the clock signal. Additionally, when switching to a clock signal produced with an external resonator or by an external oscillator while program execution is in progress, wait until the target clock signal is stable.

### 6. Voltage application waveform at input pin

Waveform distortion due to input noise or a reflected wave may cause malfunction. If the input of the CMOS device stays in the area between  $V_{IL}$  (Max.) and  $V_{IH}$  (Min.) due to noise, for example, the device may malfunction. Take care to prevent chattering noise from entering the device when the input level is fixed, and also in the transition period when the input level passes through the area between  $V_{IL}$  (Max.) and  $V_{IH}$  (Min.).

### 7. Prohibition of access to reserved addresses

Access to reserved addresses is prohibited. The reserved addresses are provided for possible future expansion of functions. Do not access these addresses as the correct operation of the LSI is not guaranteed.

### 8. Differences between products

Before changing from one product to another, for example to a product with a different part number, confirm that the change will not lead to problems. The characteristics of a microprocessing unit or microcontroller unit products in the same group but having a different part number might differ in terms of internal memory capacity, layout pattern, and other factors, which can affect the ranges of electrical characteristics, such as characteristic values, operating margins, immunity to noise, and amount of radiated noise. When changing to a product with a different part number, implement a system-evaluation test for the given product.

## Notice

1. Descriptions of circuits, software and other related information in this document are provided only to illustrate the operation of semiconductor products and application examples. You are fully responsible for the incorporation or any other use of the circuits, software, and information in the design of your product or system. Renesas Electronics disclaims any and all liability for any losses and damages incurred by you or third parties arising from the use of these circuits, software, or information.
2. Renesas Electronics hereby expressly disclaims any warranties against and liability for infringement or any other claims involving patents, copyrights, or other intellectual property rights of third parties, by or arising from the use of Renesas Electronics products or technical information described in this document, including but not limited to, the product data, drawings, charts, programs, algorithms, and application examples.
3. No license, express, implied or otherwise, is granted hereby under any patents, copyrights or other intellectual property rights of Renesas Electronics or others.
4. You shall be responsible for determining what licenses are required from any third parties, and obtaining such licenses for the lawful import, export, manufacture, sales, utilization, distribution or other disposal of any products incorporating Renesas Electronics products, if required.
5. You shall not alter, modify, copy, or reverse engineer any Renesas Electronics product, whether in whole or in part. Renesas Electronics disclaims any and all liability for any losses or damages incurred by you or third parties arising from such alteration, modification, copying or reverse engineering.
6. Renesas Electronics products are classified according to the following two quality grades: "Standard" and "High Quality". The intended applications for each Renesas Electronics product depends on the product's quality grade, as indicated below.

"Standard": Computers; office equipment; communications equipment; test and measurement equipment; audio and visual equipment; home electronic appliances; machine tools; personal electronic equipment; industrial robots; etc.

"High Quality": Transportation equipment (automobiles, trains, ships, etc.); traffic control (traffic lights); large-scale communication equipment; key financial terminal systems; safety control equipment; etc.

Unless expressly designated as a high reliability product or a product for harsh environments in a Renesas Electronics data sheet or other Renesas Electronics document, Renesas Electronics products are not intended or authorized for use in products or systems that may pose a direct threat to human life or bodily injury (artificial life support devices or systems; surgical implantations; etc.), or may cause serious property damage (space system; undersea repeaters; nuclear power control systems; aircraft control systems; key plant systems; military equipment; etc.). Renesas Electronics disclaims any and all liability for any damages or losses incurred by you or any third parties arising from the use of any Renesas Electronics product that is inconsistent with any Renesas Electronics data sheet, user's manual or other Renesas Electronics document.
7. No semiconductor product is absolutely secure. Notwithstanding any security measures or features that may be implemented in Renesas Electronics hardware or software products, Renesas Electronics shall have absolutely no liability arising out of any vulnerability or security breach, including but not limited to any unauthorized access to or use of a Renesas Electronics product or a system that uses a Renesas Electronics product. RENESAS ELECTRONICS DOES NOT WARRANT OR GUARANTEE THAT RENESAS ELECTRONICS PRODUCTS, OR ANY SYSTEMS CREATED USING RENESAS ELECTRONICS PRODUCTS WILL BE INVULNERABLE OR FREE FROM CORRUPTION, ATTACK, VIRUSES, INTERFERENCE, HACKING, DATA LOSS OR THEFT, OR OTHER SECURITY INTRUSION ("Vulnerability Issues"). RENESAS ELECTRONICS DISCLAIMS ANY AND ALL RESPONSIBILITY OR LIABILITY ARISING FROM OR RELATED TO ANY VULNERABILITY ISSUES. FURTHERMORE, TO THE EXTENT PERMITTED BY APPLICABLE LAW, RENESAS ELECTRONICS DISCLAIMS ANY AND ALL WARRANTIES, EXPRESS OR IMPLIED, WITH RESPECT TO THIS DOCUMENT AND ANY RELATED OR ACCOMPANYING SOFTWARE OR HARDWARE, INCLUDING BUT NOT LIMITED TO THE IMPLIED WARRANTIES OF MERCHANTABILITY, OR FITNESS FOR A PARTICULAR PURPOSE.
8. When using Renesas Electronics products, refer to the latest product information (data sheets, user's manuals, application notes, "General Notes for Handling and Using Semiconductor Devices" in the reliability handbook, etc.), and ensure that usage conditions are within the ranges specified by Renesas Electronics with respect to maximum ratings, operating power supply voltage range, heat dissipation characteristics, installation, etc. Renesas Electronics disclaims any and all liability for any malfunctions, failure or accident arising out of the use of Renesas Electronics products outside of such specified ranges.
9. Although Renesas Electronics endeavors to improve the quality and reliability of Renesas Electronics products, semiconductor products have specific characteristics, such as the occurrence of failure at a certain rate and malfunctions under certain use conditions. Unless designated as a high reliability product or a product for harsh environments in a Renesas Electronics data sheet or other Renesas Electronics document, Renesas Electronics products are not subject to radiation resistance design. You are responsible for implementing safety measures to guard against the possibility of bodily injury, injury or damage caused by fire, and/or danger to the public in the event of a failure or malfunction of Renesas Electronics products, such as safety design for hardware and software, including but not limited to redundancy, fire control and malfunction prevention, appropriate treatment for aging degradation or any other appropriate measures. Because the evaluation of microcomputer software alone is very difficult and impractical, you are responsible for evaluating the safety of the final products or systems manufactured by you.
10. Please contact a Renesas Electronics sales office for details as to environmental matters such as the environmental compatibility of each Renesas Electronics product. You are responsible for carefully and sufficiently investigating applicable laws and regulations that regulate the inclusion or use of controlled substances, including without limitation, the EU RoHS Directive, and using Renesas Electronics products in compliance with all these applicable laws and regulations. Renesas Electronics disclaims any and all liability for damages or losses occurring as a result of your noncompliance with applicable laws and regulations.
11. Renesas Electronics products and technologies shall not be used for or incorporated into any products or systems whose manufacture, use, or sale is prohibited under any applicable domestic or foreign laws or regulations. You shall comply with any applicable export control laws and regulations promulgated and administered by the governments of any countries asserting jurisdiction over the parties or transactions.
12. It is the responsibility of the buyer or distributor of Renesas Electronics products, or any other party who distributes, disposes of, or otherwise sells or transfers the product to a third party, to notify such third party in advance of the contents and conditions set forth in this document.
13. This document shall not be reprinted, reproduced or duplicated in any form, in whole or in part, without prior written consent of Renesas Electronics.
14. Please contact a Renesas Electronics sales office if you have any questions regarding the information contained in this document or Renesas Electronics products.

(Note1) "Renesas Electronics" as used in this document means Renesas Electronics Corporation and also includes its directly or indirectly controlled subsidiaries.

(Note2) "Renesas Electronics product(s)" means any product developed or manufactured by or for Renesas Electronics.

(Rev.5.0-1 October 2020)

## Corporate Headquarters

TOYOSU FORESIA, 3-2-24 Toyosu,  
Koto-ku, Tokyo 135-0061, Japan  
[www.renesas.com](http://www.renesas.com)

## Trademarks

Renesas and the Renesas logo are trademarks of Renesas Electronics Corporation. All trademarks and registered trademarks are the property of their respective owners.

## Contact information

For further information on a product, technology, the most up-to-date version of a document, or your nearest sales office, please visit:  
[www.renesas.com/contact/](http://www.renesas.com/contact/).