RX260 Group , RX261 Group

HMI sample program with touch keys and LCD

Introduction

This application note describes a sample program to realize touch function and serial LCD display using EK-RX261 v1 and separately sold LCD module.

The sample program described in this application note is configured using the following libraries.

LCD Display : Embedded GUI software emWin (hereinafter referred to as “emWin”)

Target Device

RX261 Group

When using this application note with other Renesas MCUs, careful evaluation is recommended after making modifications to comply with the alternate MCU.

Contents

1. Outline.....	4
2. Operation Confirmation Conditions	6
3. Hardware Preparation.....	7
3.1 Power supply setting	7
3.2 Connecting to LCD module	7
4. Sample Program.....	8
4.1 Demonstration Screen Flowchart.....	8
4.2 Flowchart	11
4.2.1 Overall Flowchart.....	11
4.2.2 Processing at touch keys operation	12
4.2.3 Processing at 2-button tap, press and hold operation.....	13
4.2.4 Processing when both buttons 1 and 2 are pressed and held simultaneously.	14
4.2.5 Processing when the "1" button is touched (1)	15
4.2.6 Processing when the "1" button is touched (2)	16
4.2.7 Processing of CTSU2SLa initialization.....	17
4.2.8 Processing of CTSU2SLa baseline settings	18
4.2.9 Processing of software standby mode transition and CTSU2SLa low power consumption measurement.....	19
4.2.10 Processing of normal operation mode transition.....	20
4.2.11 Processing of CTSU2SLa normal measurement	21
4.2.12 Processing of touch judgement.....	22
4.3 Pins Used	23
4.4 Sample Program Structure	23
4.4.1 Peripheral Functions Used	23
4.4.2 Peripheral Function Settings	24
4.4.3 File Structure	26
4.4.4 Variables.....	27
4.4.5 Constants	27
4.4.6 Functions	28
4.4.7 Function Specifications	29
4.4.8 ROM/RAM usage	35
5. Importing a Project.....	36
5.1 Procedure in e ² studio	36
5.2 Procedure in CS+	37
6. Start Demonstration.....	38
6.1 Powered on EK-RX261 v1 and menu screen	39
6.2 Menu screen.....	39

6.3	Cook setting.....	40
6.3.1	Move to mode selection screen.....	40
6.3.2	Select mode.....	40
6.3.3	Select Auto	41
6.3.4	Select Manual.....	41
6.3.4.1	Set the number of watts	42
6.3.4.2	Move the cursor.....	42
6.3.4.3	Set the number of seconds	43
6.3.4.4	Start cooking	43
6.4	Defrost setting	44
6.4.1	Move to mode selection screen.....	44
6.4.2	Select mode.....	44
6.4.3	Select Manual.....	45
6.4.3.1	Set the level of defrosting.....	45
6.4.3.2	Move the cursor.....	46
6.4.3.3	Set the number of grams.....	46
6.4.3.4	Start defrosting	47
6.4.4	Select Fish.....	47
6.4.5	Select Meat.....	48
6.5	Recipe setting.....	49
6.5.1	Move to recipe selection screen.....	49
6.5.2	Select recipe.....	49
6.5.3	Select Beef Stew	50
6.5.4	Select Garlic Shrimp.....	50
6.5.5	Select Cup Cake.....	51
6.5.5.1	Set the number of cupcakes	51
6.5.5.2	Start cooking	52
6.6	Simultaneous press and hold both buttons 1 and 2.....	53
6.7	About the cooking completion screen	54
6.8	Smart wakeup function.....	54
7.	Reference Documents	55
	Revision History.....	56

1. Outline

This application note describes a sample program to realize touch function and serial LCD display using EK-RX261 v1 and separately sold LCD module.

The touch buttons and LCD (240 x 320) module in EK-RX261 v1 are used to control the configuration and display of the UI, which imitates a microwave oven.

The system configuration is shown below.

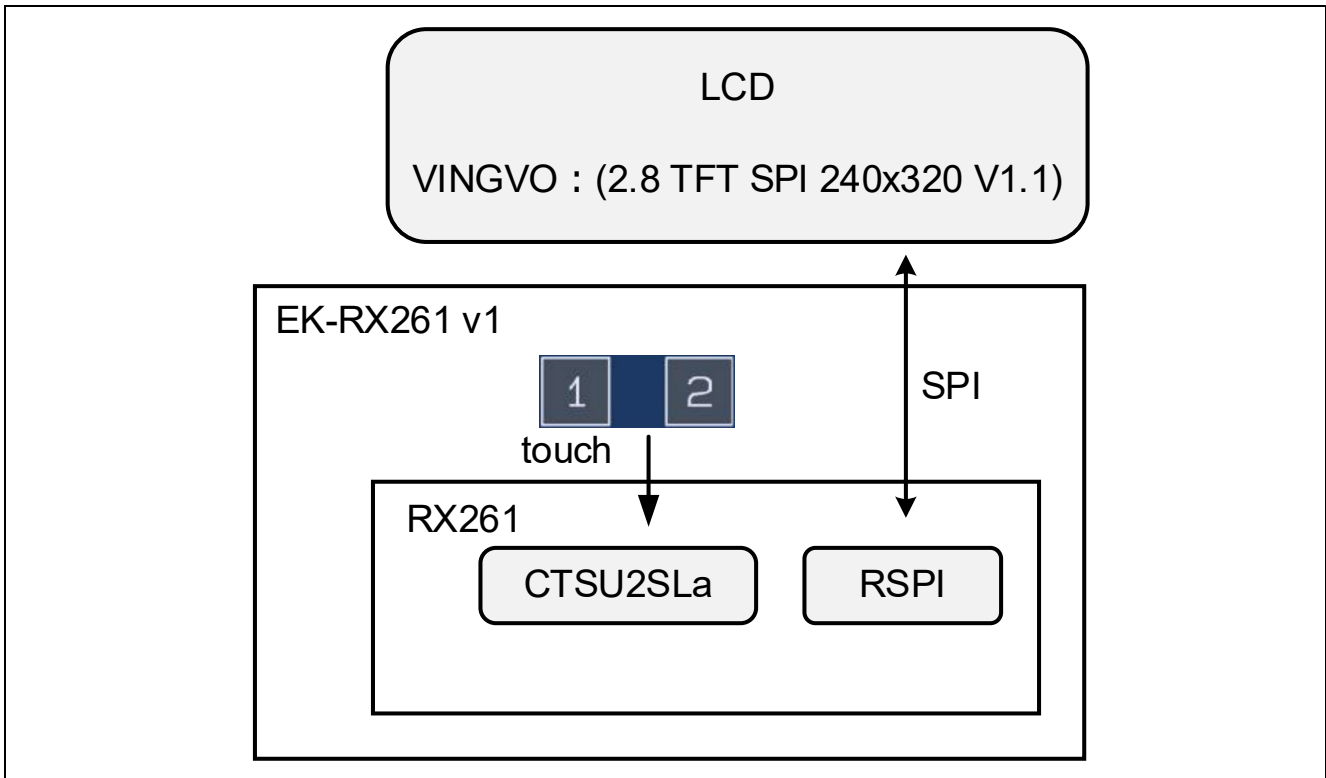

Figure 1-1 System configuration

The system configuration is shown below.

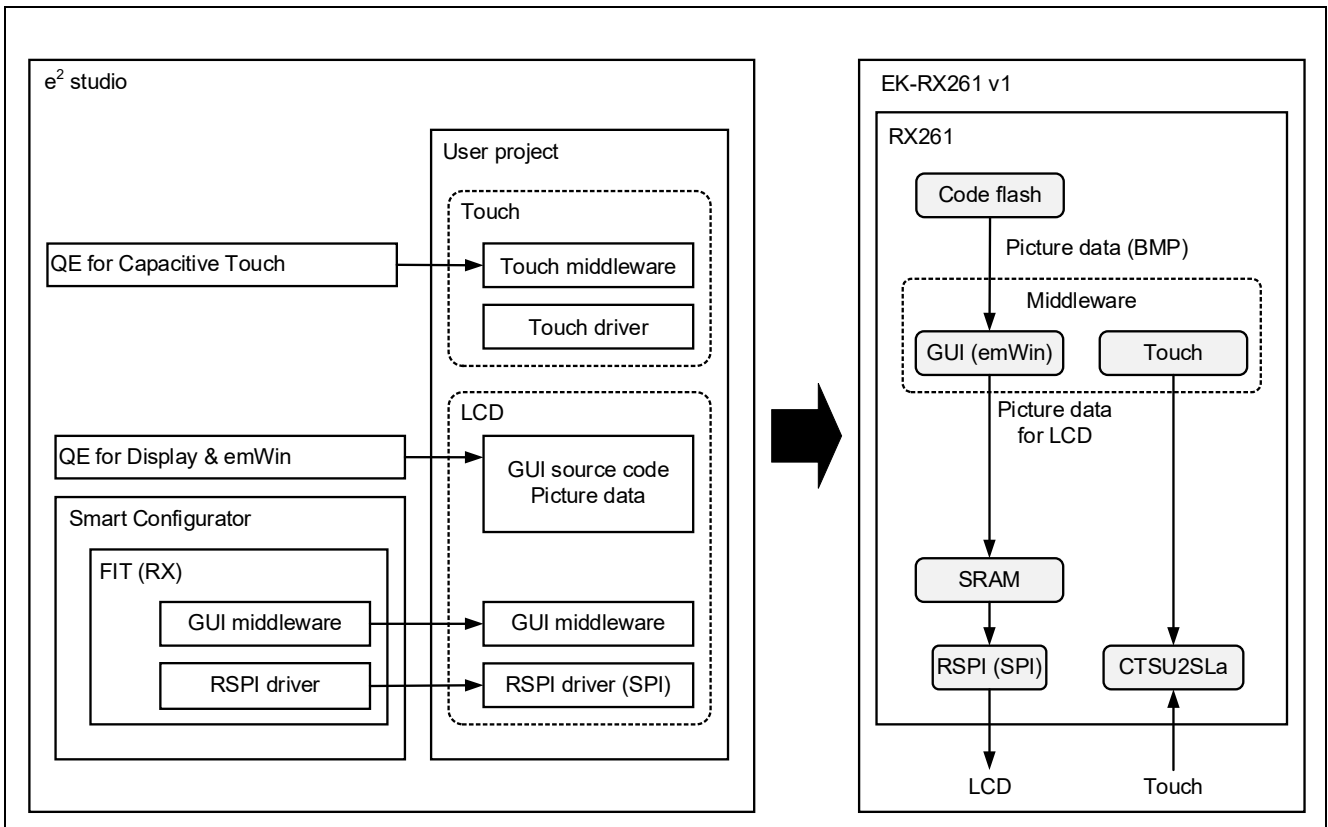

Figure 1-2 Software configuration

2. Operation Confirmation Conditions

The operation of the sample program has been confirmed under the following conditions.

Table 2-1 Operation Confirmation Conditions

Item	Contents
MCU used	R5F52618BGFP (RX261 Group)
Operating frequency	Operating frequency (ICLK) : 64MHz Peripheral operating frequency (PCLKB) : 32MHz
Operating voltage	5V
Integrated development	Renesas Electronics e ² studio Version 2024-10 (24.10.0)
C compiler	Renesas Electronics C/C++ Compiler Package for RX Family V3.06.00
	Compiler option — optimize=level 2 — size
Smart Configurator	RX 2.23.0
Board support package (r_bsp)	V7.51
Endian order	Little Endian
Operating mode	Single chip mode
Processor mode	Super visor mode
Sample code version	V1.00
Emulator	E2 Emulator Lite
Board used	EK-RX261 v1 (RTK5EK2610S00001BE)

Table 2-2 Operation Confirmation Conditions (LCD)

Item	Contents
LCD module	2.8 TFT SPI 240 x 320 serial port module

3. Hardware Preparation

3.1 Power supply setting

The power supply of EK-RX261 v1 used in this application note should be set as follows. For details, refer to "4.4.3 Initial Settings of Jumpers" in "RX261 Group EK-RX261 v1 User's Manual".

Table 3-1 Power supply setting

J5,J6,J24,J32,J33,J34	J18,J19,J23,J31	J20,J21,J22,J25
1-2 Shorted	2-3 Shorted	Open

3.2 Connecting to LCD module

Connect EK-RX261 v1 to the LCD module as follows

Table 3-2 Connection table

EK-RX261 v1		2.8 TFT LCD Panel (J2)		Supplement
Pin number	Pin Name	Pin Number	Pin Name	
-	-	14	T_IRQ	OPEN
-	-	13	T_DO	OPEN
-	-	12	T_DIN	OPEN
-	-	11	T_CS	OPEN
-	-	10	T_CLK	OPEN
J2-22(45:PC7)	MISOA	9	MISO	-
J2-20(43:P51)	GPIO/CSA	8	LED	-
J2-24(47:PC5)	RSPCKA	7	SCK	-
J2-23(46:PC6)	MOSIA	6	MOSI	-
J2-26(49:PC3)	GPIO/DC	5	D/C	-
J2-21(44:P50)	GPIO/RESET	4	RESET	-
J2-19(42:P52)	GPIO/CS-LCD	3	CS	-
J2-28(GND)	GND	2	GND	-
J2-1 (VCC)	3V3/5V	1	VCC	-

EK-RX261 v1		2.8 TFT LCD Panel (J4)		Supplement
Pin number	Pin Name	Pin Number	Pin Name	
-	-	1	SD_CS	OPEN
-	-	2	SD_MOSI	OPEN
-	-	3	SD_MISO	OPEN
-	-	4	SD_SCK	OPEN

4. Sample Program

4.1 Demonstration Screen Flowchart

The demonstration screen flowchart of this sample program is shown below. For detail on each screen, refer to chapter 6.

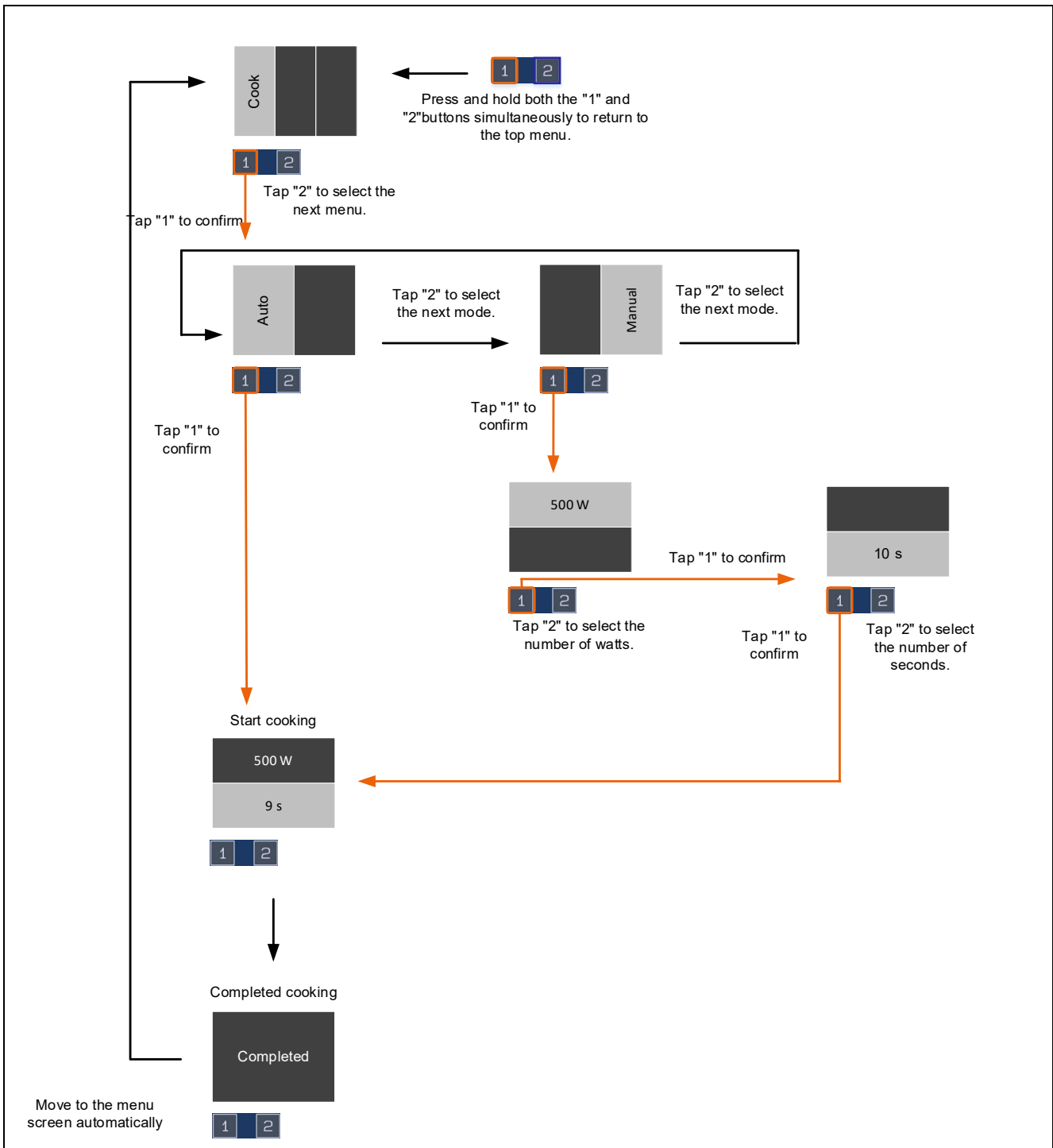

Figure 4-1 Flowchart of demonstration screen (Cook)

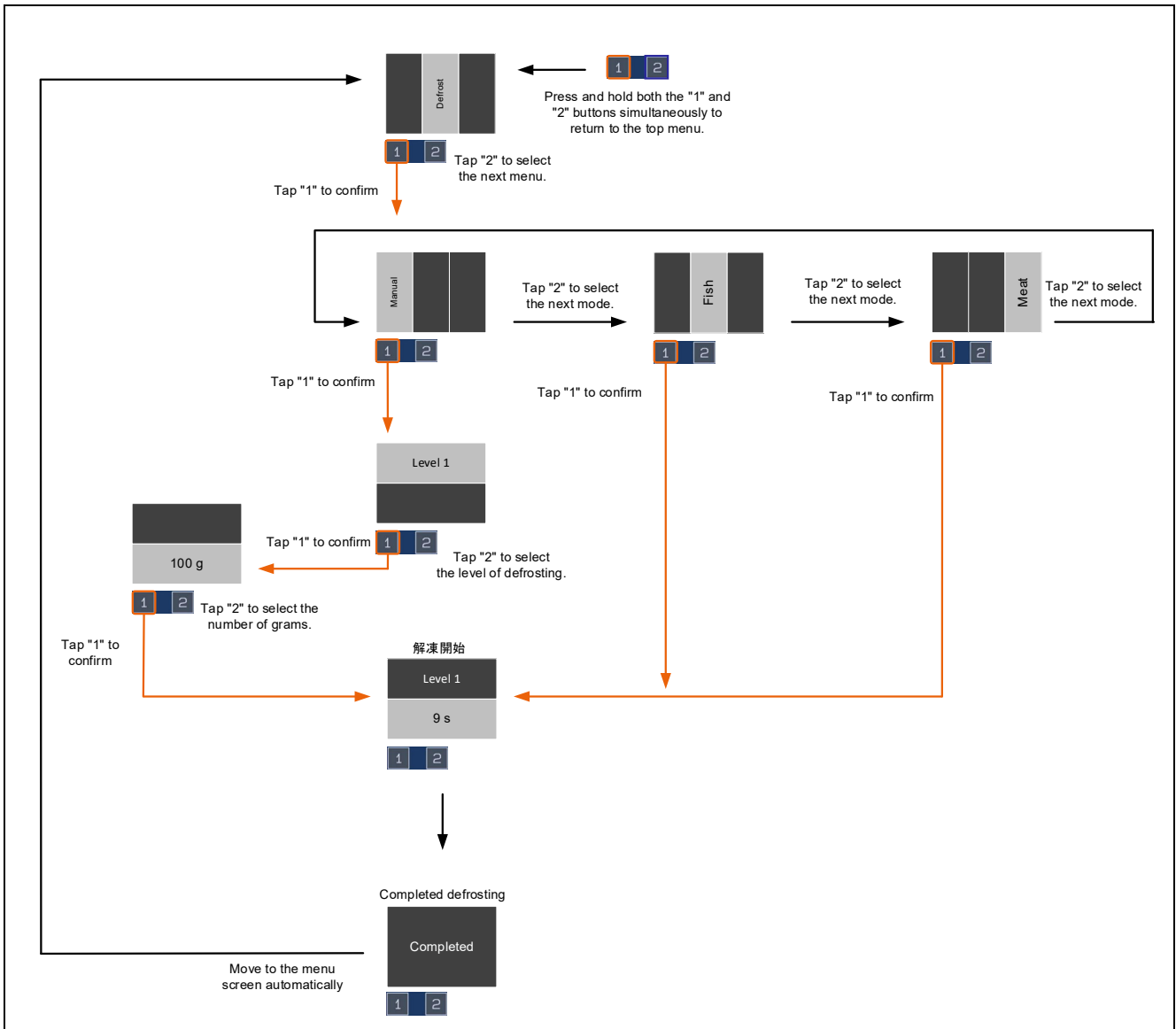

Figure 4-2 Flowchart of demonstration screen (Defrost)

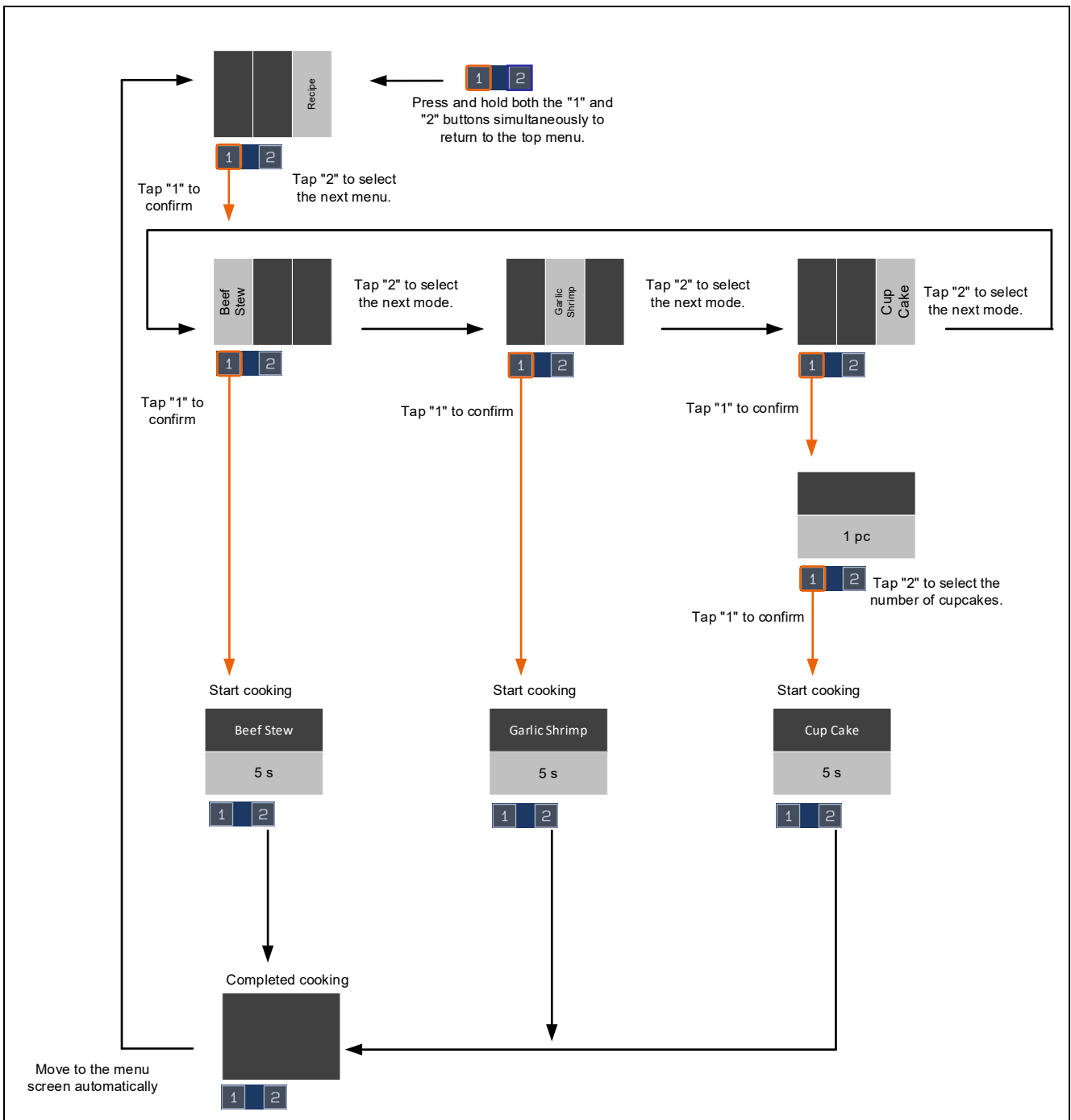

Figure 4-3 Flowchart of demonstration screen (Recipe)

4.2 Flowchart

4.2.1 Overall Flowchart

The overall flowchart is shown below.

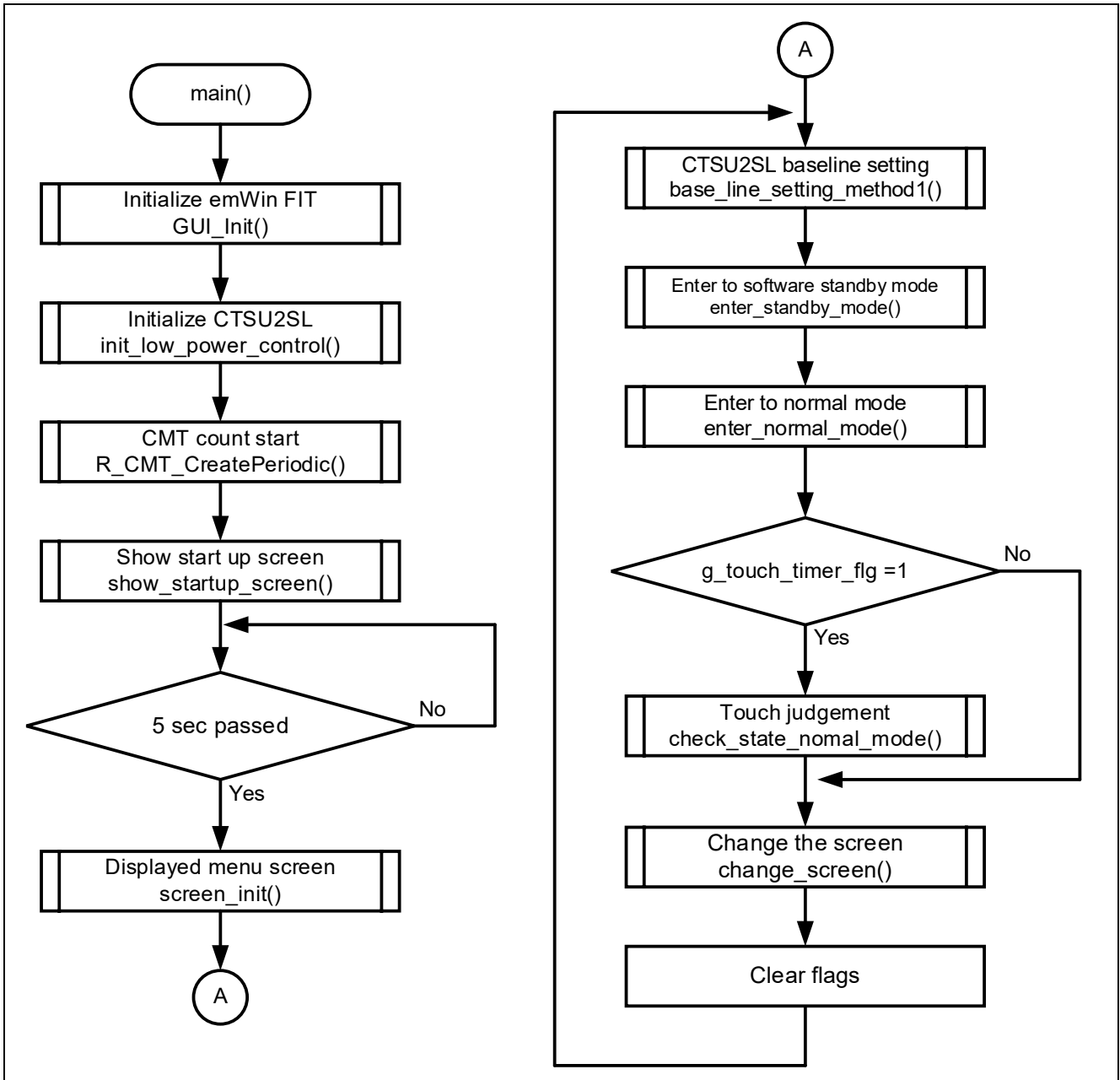

Figure 4-4 Overall flowchart

4.2.2 Processing at touch keys operation

The flowchart for touch keys operation is shown below.

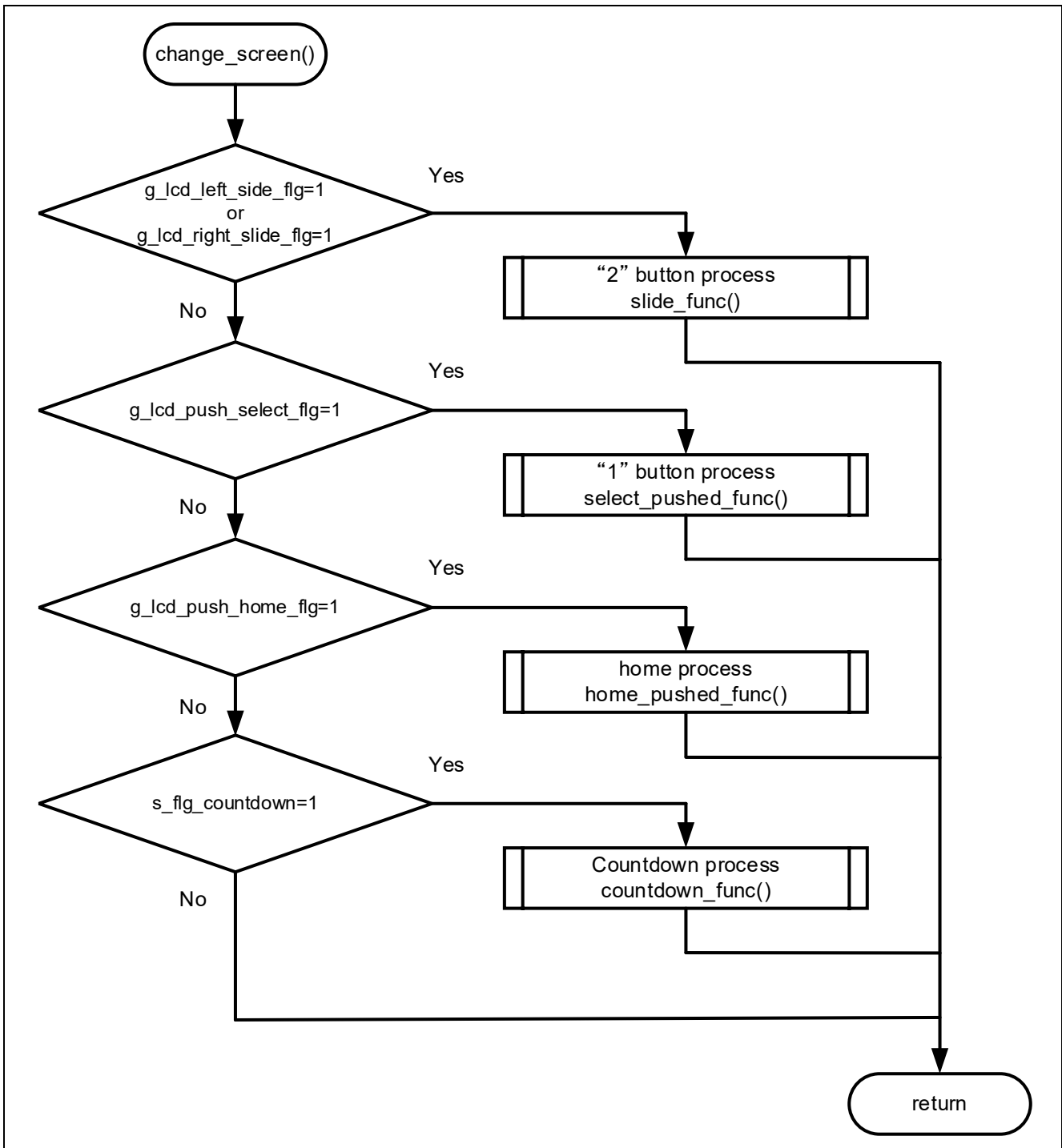

Figure 4-5 Flowchart for touch keys operation

4.2.3 Processing at 2-button tap, press and hold operation

The flowchart for 2-button tap, press and hold operation is shown below.

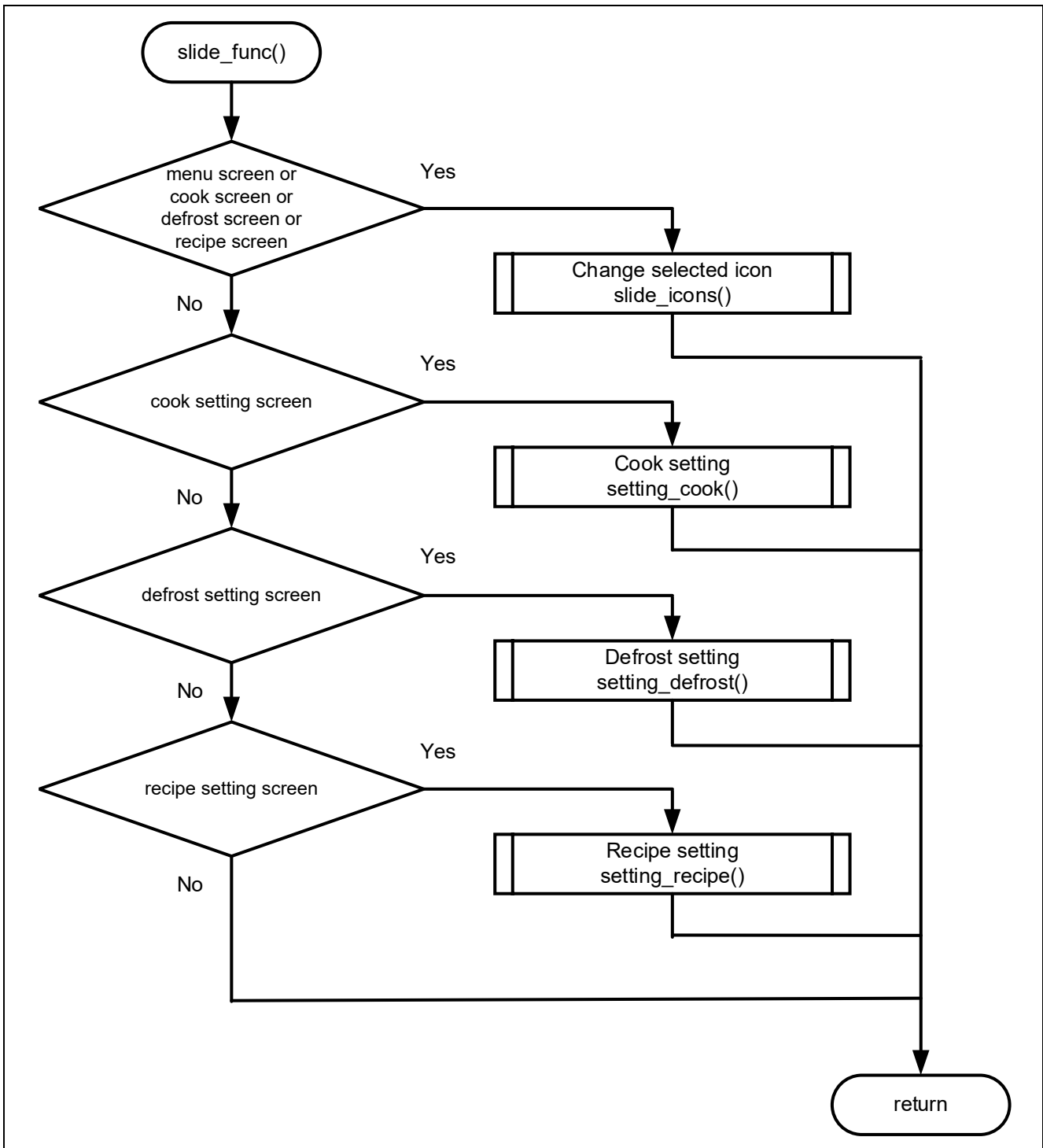

Figure 4-6 Flowchart for 2-button tap, press and hold operation

4.2.4 Processing when both buttons 1 and 2 are pressed and held simultaneously.

The flowchart for the simultaneous press and hold both buttons 1 and 2 is shown below.

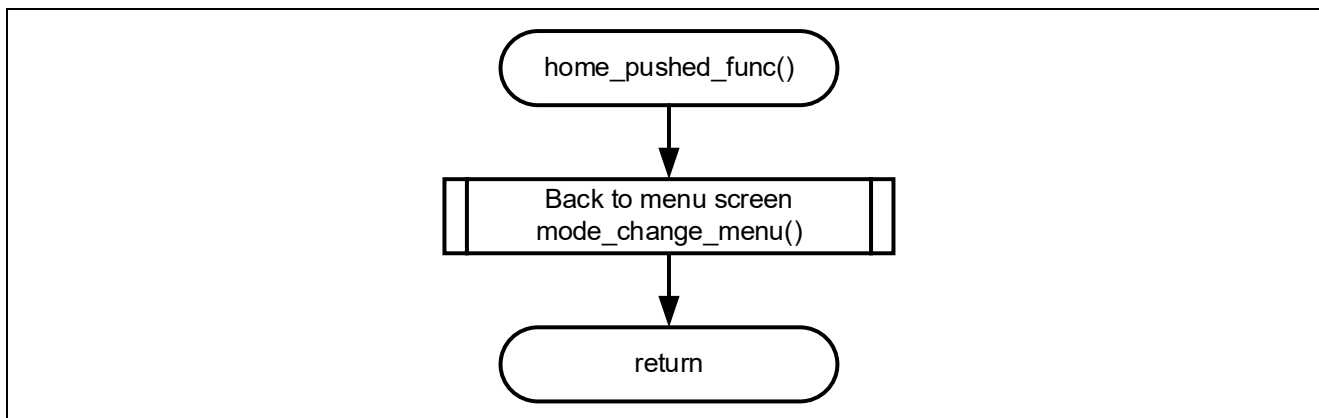

Figure 4-7 Flowchart for the simultaneous press and hold both buttons 1 and 2

4.2.5 Processing when the "1" button is touched (1)

The flowchart when the "1" button is touched is shown below.

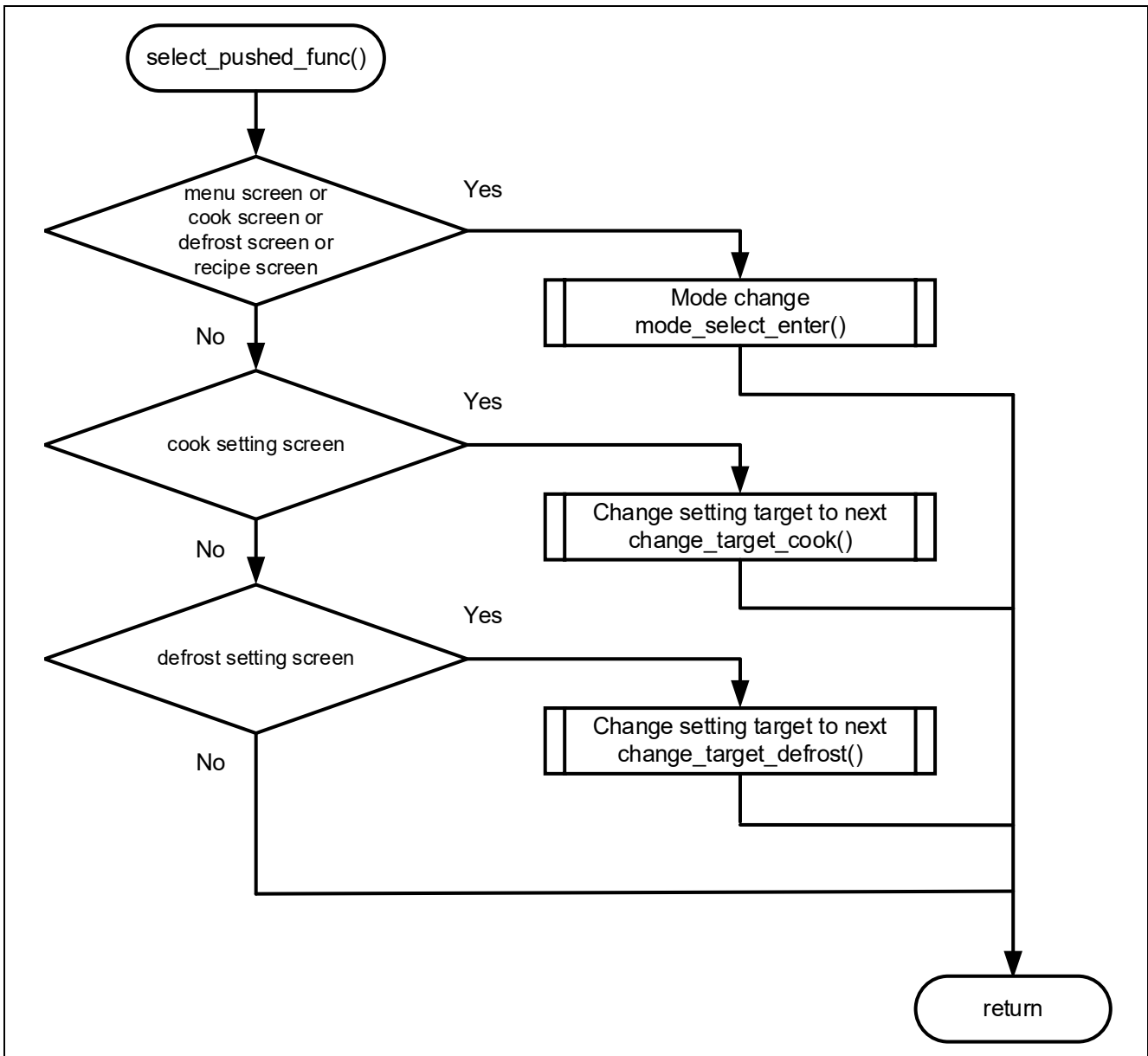

Figure 4-8 Flowchart when the "1" button is touched

4.2.6 Processing when the "1" button is touched (2)

The flowchart when the "1" button is touched is shown below.

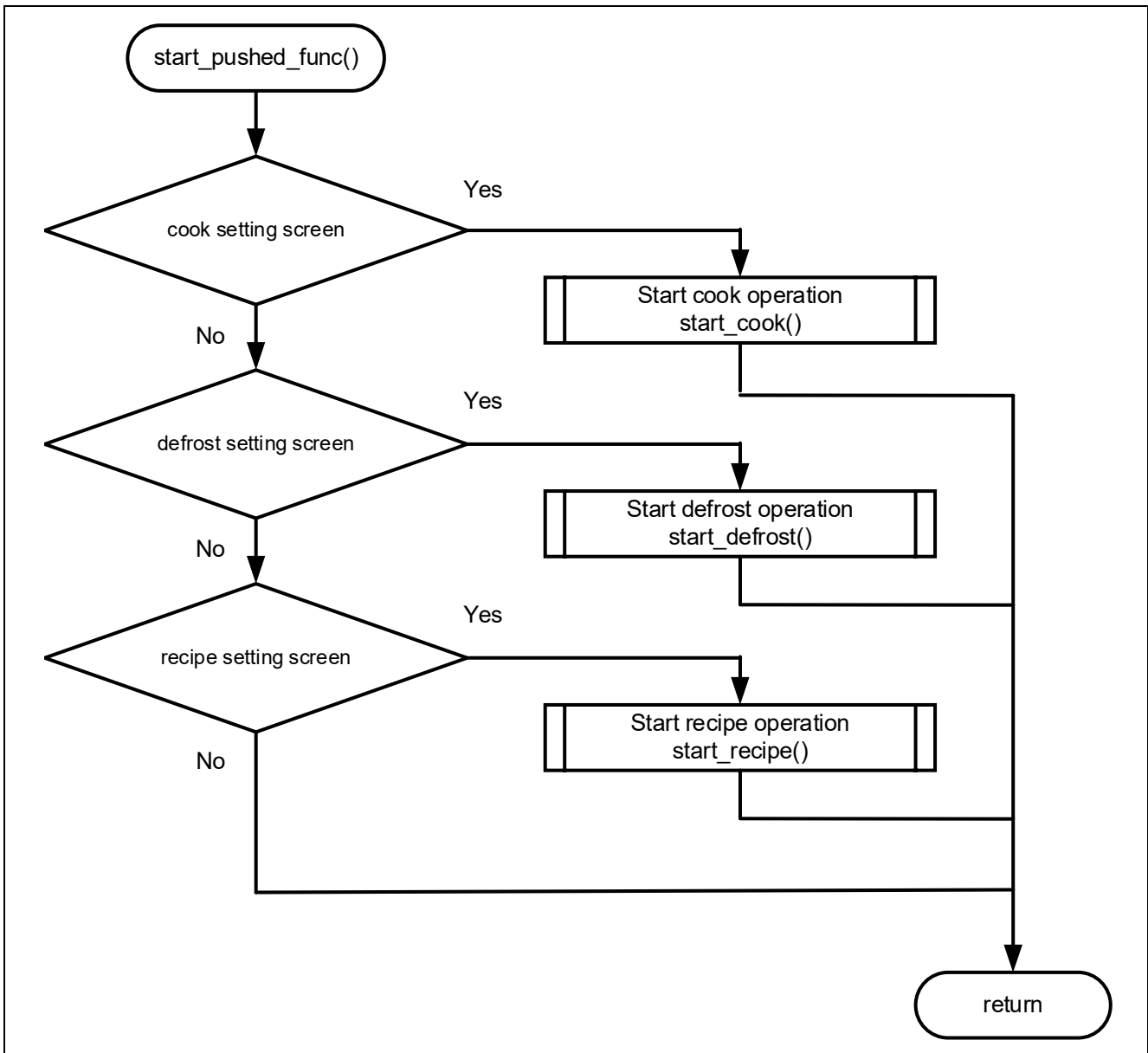

Figure 4-9 Flowchart when the "1" button is touched

4.2.7 Processing of CTSU2SLa initialization

The flowchart of CTSU2SLa initialization is shown below.

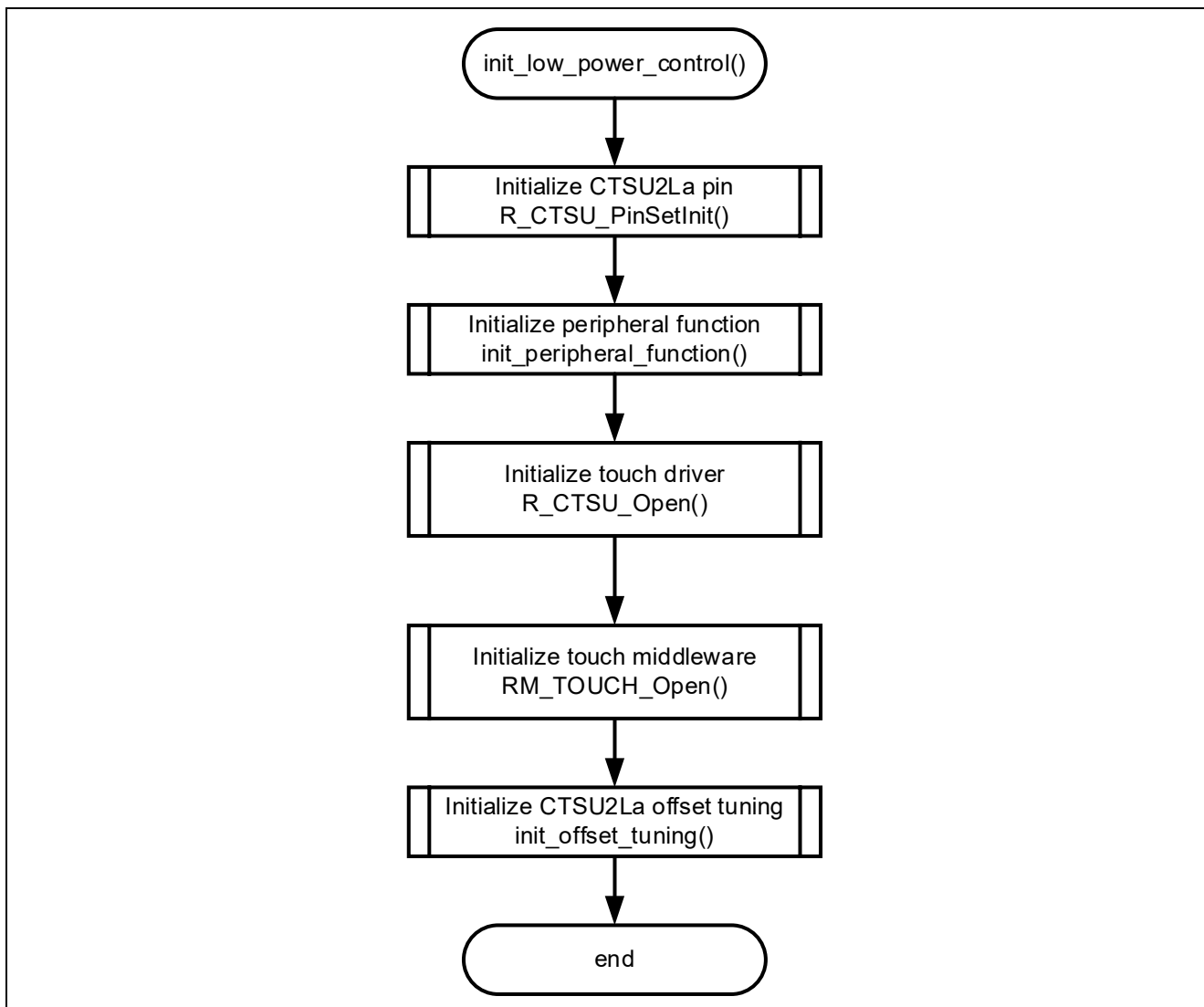

Figure 4-10 Flowchart of CTSU2SLa initialization

4.2.8 Processing of CTSU2SLa baseline settings

The flowchart of CTSU2SLa baseline settings is shown below.

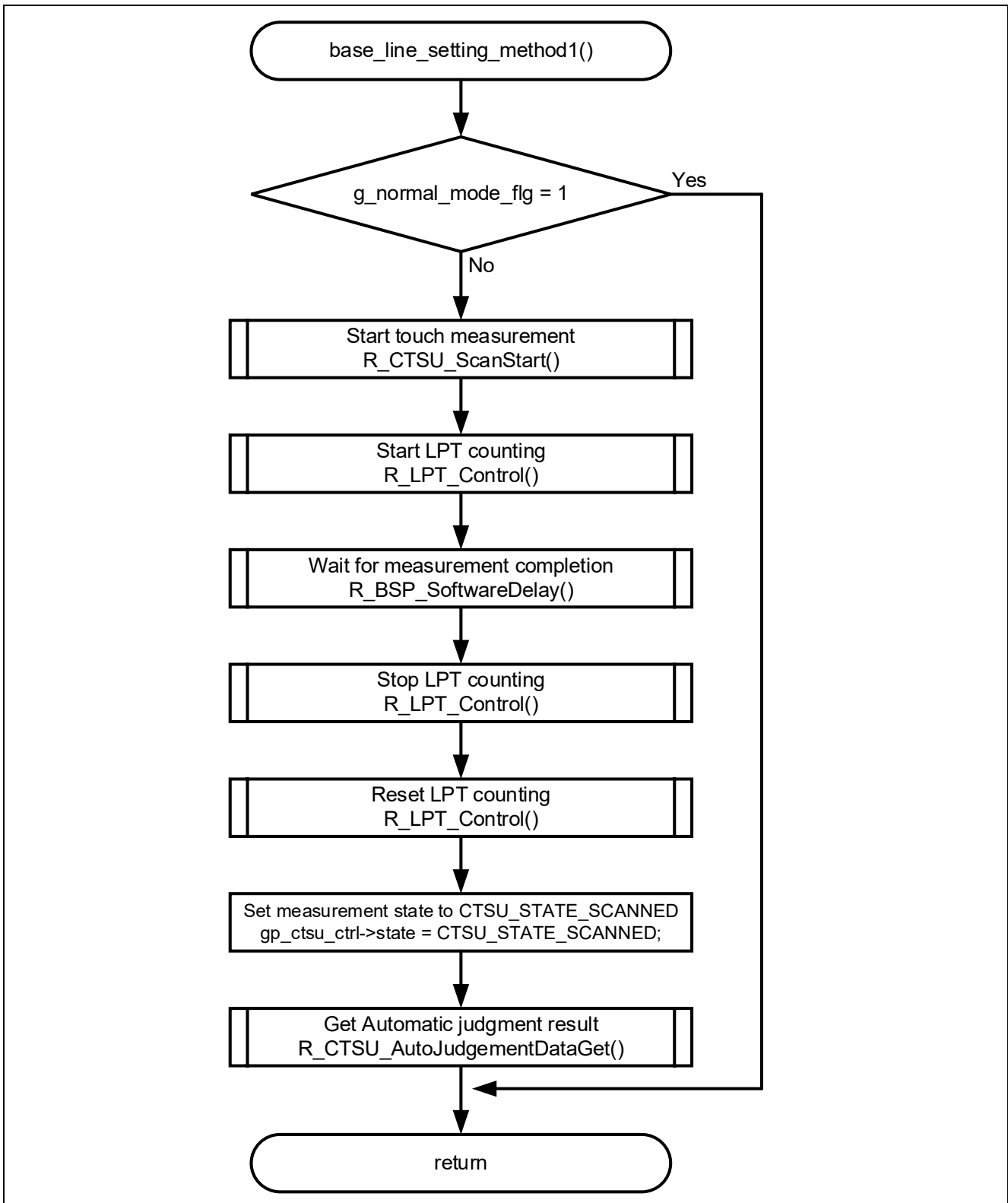

Figure 4-11 Flowchart of CTSU2SLa baseline settings

4.2.9 Processing of software standby mode transition and CTSU2SLa low power consumption measurement

The flowchart of software standby mode transition and CTSU2SL low power consumption measurement is shown below.

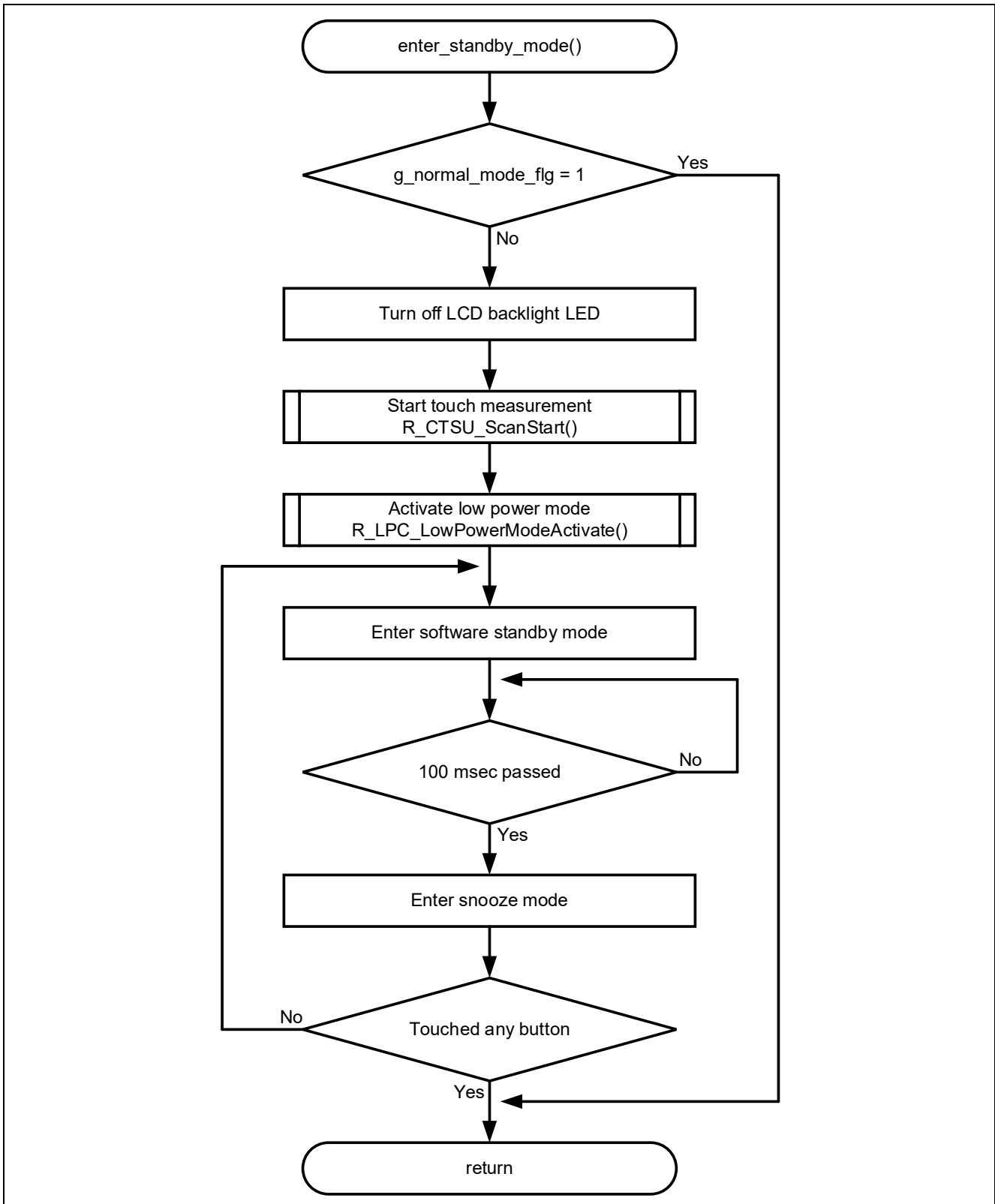

Figure 4-12 Flowchart of software standby mode transition and CTSU2SLa low power consumption measurement

4.2.10 Processing of normal operation mode transition

The flowchart of normal operation mode transition is shown below.

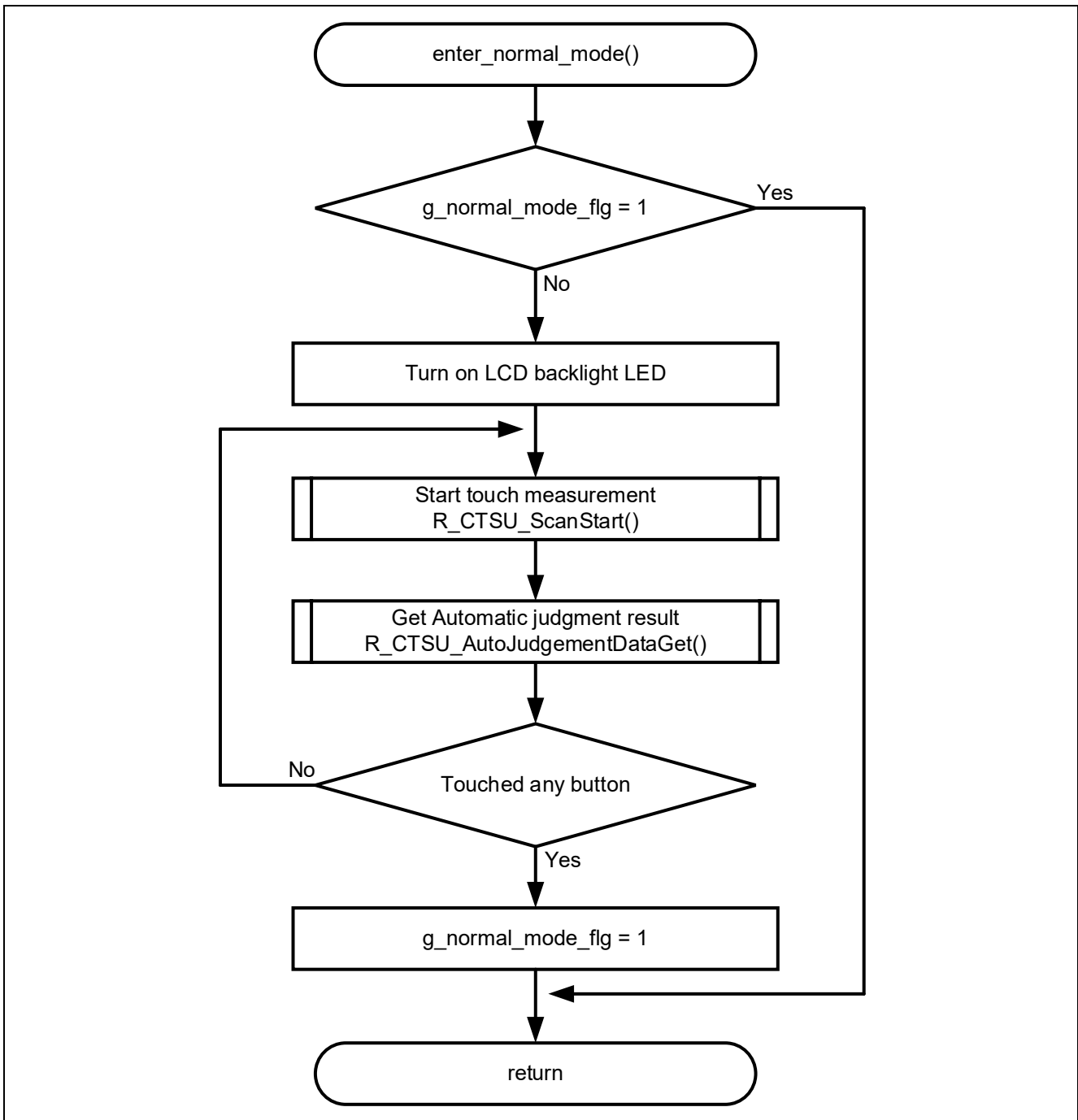

Figure 4-13 Flowchart of normal operation mode transition

4.2.11 Processing of CTSU2SLa normal measurement

The flowchart of CTSU2SLa normal measurement is shown below.

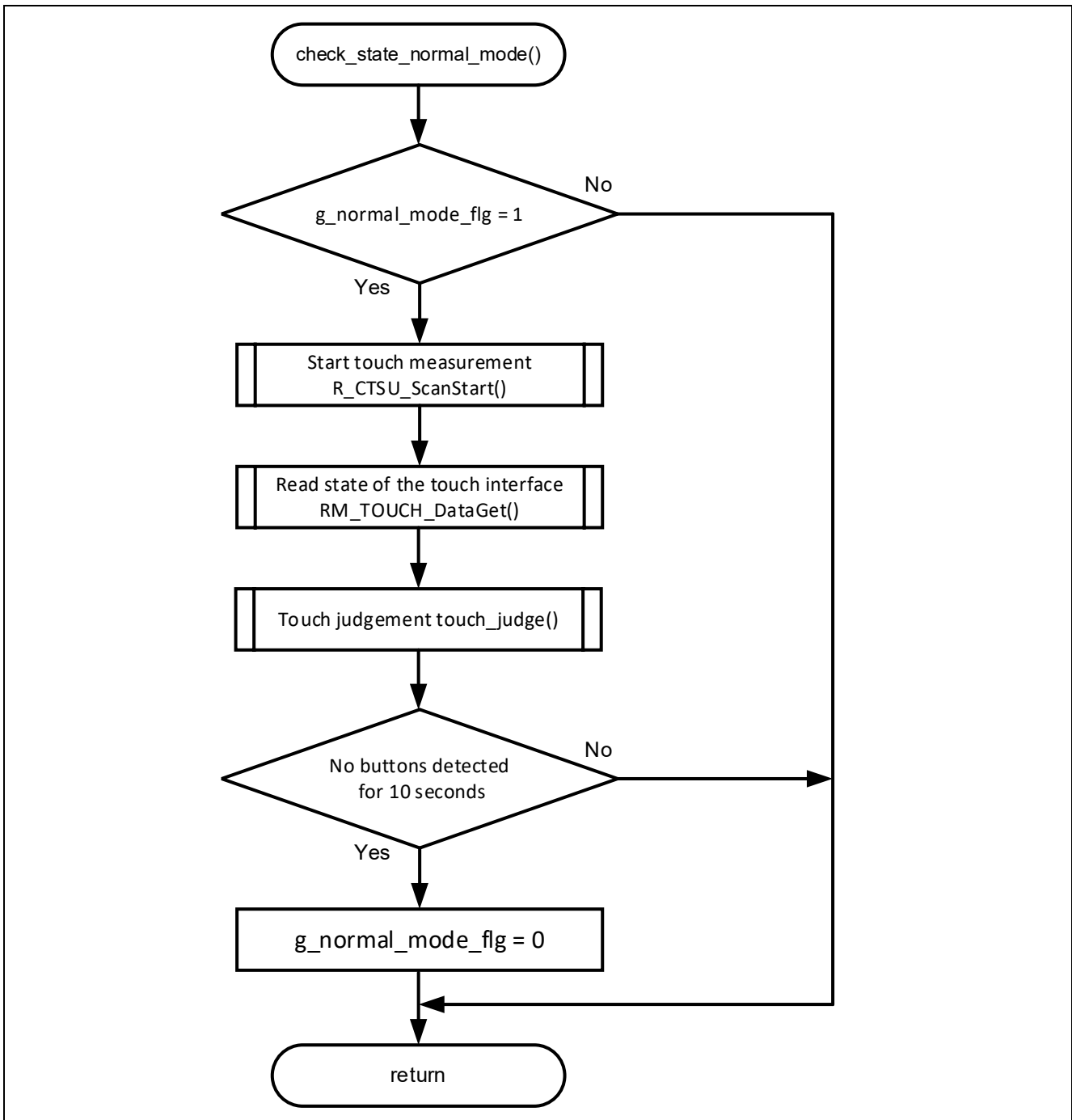

Figure 4-14 Flowchart of CTSU2SLa normal measurement

4.2.12 Processing of touch judgement

The flowchart of touch judgement is shown below.

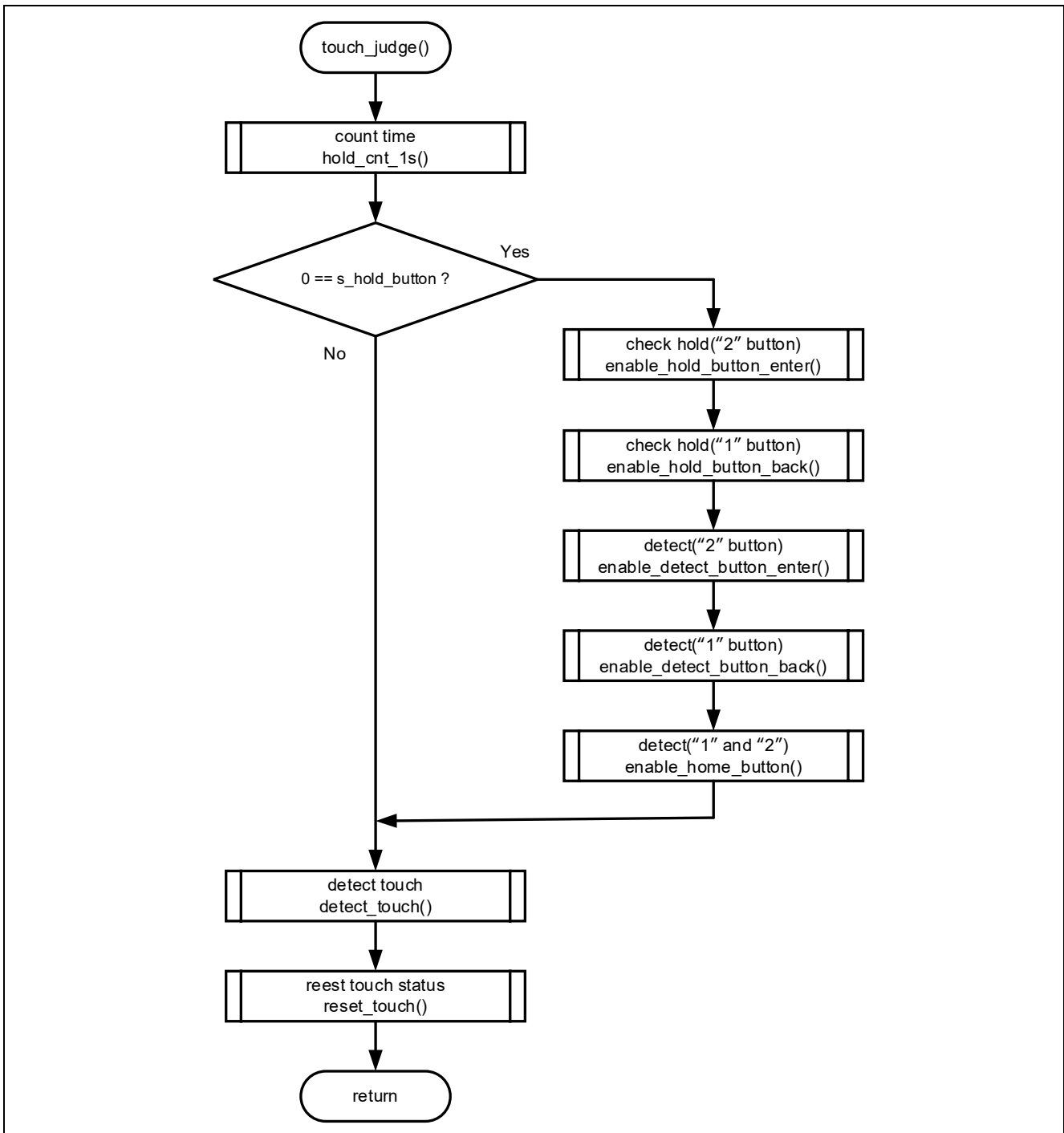

Figure 4-15 Flowchart of touch judgement

4.3 Pins Used

The following shows lists pins used in this sample program.

Table 4-1 List of Pins and Functions

Pin Name	Input/Output	Function
PC5/RSPCKA	output	RSPI clock pin
PC7/MISOA	input	RSPI MISO pin
PC6/MOSI	output	RSPI MOSI pin
PC4/CSA	output	RSPI CS pin
PC3/GPIO	output	LCD D/C pin
P50/GPIO	output	LCD RESET pin
P51/GPIO	output	LCD CS
P32/TS01	input	Electrostatic capacitance measurement pin
P27/TS03	input	Electrostatic capacitance measurement pin

4.4 Sample Program Structure

4.4.1 Peripheral Functions Used

The following shows lists peripheral functions used in this sample program.

Table 4-2 List of Peripheral Functions Used and Functions

Peripheral Functions	Function
RSPI	SPI Communication with LCD
DTC	Used for measure CTSU2SLa during snooze mode
DMAC	Used for internal emWin FIT
ELC	Used for measure CTSU2SLa during software standby mode
CTSU2SLa	Used for with touch buttons
CMT0	Used for internal emWin FIT
CMT2	Used for measure CTSU2SLa during normal operation mode
LPT	Used for ELC triggering

4.4.2 Peripheral Function Settings

The Smart Configurator settings used in this sample program are shown below. The items and settings in each table in the Smart Configurator settings are described in the notation on the configuration screen.

Settings not listed are assumed to be default settings.

Table 4-3 Parameters of Smart Configurator (1/2)

Category	Item	Setting/Description
Smart Configurator >> Clock		The following settings are made on the "Clocks" Tab.
	VCC	3.3 (V)
	Main clock	Stopped: Checked. Main clock oscillation enabled after reset
	HOCO clock	Stopped: UnChecked.
	LOCO clock	Stopped: Unchecked.
	IWDT dedicated clock	Operation: Checked. Frequency: 15 (kHz)
	System clock	Clock source: HOCO Flash IF clock (FCLK): 64MHz System clock (ICLK): 64MHz Peripheral module clock (PCLKB): 32MHz Peripheral module clock (PCLKD): 64MHz CLKOUT pin: Unchecked. Low power timer clock (LPTCLK) : 15kHz
Smart Configurator >> System		Debugging interfaces setting: FINE
Smart Configurator >> Components >> r_bsp		Other than the changes listed below, default settings are used.
	Heap size	0x4000
	Software Interrupt Unit1 (SWINT1)	Unused
Smart Configurator >> Components >> r_dmaca_rx		Other than the changes listed below, default settings are used.
	DMAC FIT check	DMAC FIT modules is not used with DTC FIT module.
Smart Configurator >> Components >> r_dtc_rx		Default settings are used.
Smart Configurator >> Components >> r_elc_rx		Default settings are used.
Smart Configurator >> Components >> r_cts_uqe		Other than the changes listed below, default settings are used.
	Data transfer of INTCTSUWR and INTCTSURD	DTC
	Select automatic judgement code	Enable
	TSCAP pin	Use: Checked.
	TS1 pin	Use: Checked.
	TS3 pin	Use: Checked.
Smart Configurator >> Components >> r_gpio_rx		Default settings are used.
Smart Configurator >> Components >> r_lpc_rx		Default settings are used.
Smart Configurator >> Components >> r_rsipi_rx		Default settings are used.

Table 4-4 Parameters of Smart Configurator (2/2)

Category	Item	Setting/Description
Smart Configurator >> Components >> r_cmt_rx		Default settings are used.
Smart Configurator >> Components >> r_lpt_rx		Other than the changes listed below, default settings are used.
	LPT clock source	IWDT-dedicated on-chip oscillator
Smart Configurator >> Components >> rm_touch_qe		Default settings are used.
Smart Configurator >> Components >> r_byteq		Default settings are used.
Smart Configurator >> Components >> r_emwin_rx		Other than the changes listed below, default settings are used.
	Configurations >> BasicSetting	
	Work area size for GUI	10240
	Horizontal LCD size	240
	Vertical LCD size	320
	Color depth	16 bit per pixel
	LCD orientation	ORIENTATION_CW
	Configurations >> Select LCD Interface	
	LCD interface	LCD_IF_SCI_SPI
	Select LCD Driver IC	LCD_DRV_IC_ILI9341
	Communication baud rate of LCD interface	16000000
	Use or unused display cache	Unuse
	Configurations >> Select LCD Interface >> LCD Interface Pin Setting	
	Use Display Signal Pin	Use Display Signal Pin
	Display Signal Pin	GPIO_PORT_5_PIN_0
	Use Backlight Pin	Use Backlight Pin
	Backlight Pin	GPIO_PORT_5_PIN_1
	Use Data/Command Pin	Use Data/Command Pin
	Data/Command Pin	GPIO_PORT_C_PIN_3
	Use Chip Select Pin	Use Chip Select Pin
	Chip Select Pin	GPIO_PORT_5_PIN_2
	Configurations >> Select Touch Interface	
	Use Touch function	Not use Touch function

4.4.3 File Structure

The following shows file structure by sample program.

Table 4-5 File Structure

Folder name, File name	Outline
src	Folder for program source
└ main.c	Source file for main processing
└ main.h	Header file for main processing
└ LCD_custom_func.c	Source file for LCD related
└ LCD_custom_func.h	Header file for LCD related
└ r_low_power_control.c	Source file for operation mode control related
└ r_low_power_control.h	Header file for operation mode control related
└ touch_func.c	Source file for touch related
└ touch_func.h	Header file for touch related
└ Resource	Folder for image and font
└ smc_gen	Smart Configurator generation
└└ r_byteq	
└└ r_cmt_rx	
└└ r_ctsu_qe	
└└ r_dtc_rx	
└└ r_dmaca_rx	
└└ r_elc_rx	
└└ r_emwin_rx	
└└ r_gpio_rx	
└└ r_lpc_rx	
└└ r_lpt_rx	
└└ r_rspi_rx	
└└ rm_touch_qe	
└└ general	
└└ r_bsp	
└└ r_config	
└└└ r_pincfg	
qe_gen	QE-Touch generation
QE-Touch	

4.4.4 Variables

The following shows the variables that are used in this sample program.

Table 4-6 List of variables used in the sample code

Variable name	Type	Contents
g_normal_mode_flg	uint8_t	The Normal operation mode flag
g_touch_timer_flg	uint8_t	The touch judgement start flag in normal operation mode
g_lcd_left_slide_flg	uint8_t	The "2" button pressed-and-held detection flag
g_lcd_right_slide_flg	uint8_t	The "2" button was touched flag
g_lcd_push_home_flg	uint8_t	The "1" and "2" buttons pressed-and-held detection flag
g_lcd_push_select_flg	uint8_t	The "1" button was touched flag

4.4.5 Constants

The following shows the constants that are used in this sample program.

Table 4-7 List of constants used in the sample code

Constant Name	Setting Value	Contents
CMT_FREQ	(50U)	CMT interval (milliseconds)
STARTUP_TIME	(5U)	Initial screen display time (Seconds)
STARTUP_COUNT	(STARTUP_TIME * CMT_FREQ)	Initial screen display time (Count)

4.4.6 Functions

The following shows the functions that are used in this sample program.

Table 4-8 List of functions used in the sample code

Function name	Outline
main	Main process
GUI_Init	Initializing emWin
R_CMT_CreatePeriodic	CMT counting start
change_screen	LCD screen update
slide_func	Processing when "2" button is touched, or when the "2" button is pressed and held.
select_pushed_func	Processing when "1" button is touched
home_pushed_func	Processing when "1" and "2" button is pressed and held
start_pushed_func	Processing when "1" button is touched
countdown_func	Processing the countdown
slide_icons	Processing of cursor movement on menu screens and mode selection screens for Cook, Defrost and Recipe
setting_cook	Setting the number of watts and seconds in Cook mode
setting_defrost	Setting the level of defrosting and the number of grams in Defrost mode
setting_recipe	Setting the number of cupcakes in Recipe mode
mode_select_enter	Change the mode and display the LCD screen according to the mode
change_target_cook	Change the setting target of the detail setting screen in Cook mode
change_target_defrost	Change the setting target of the detail setting screen in Defrost mode
mode_change_menu	Move to the menu screen
start_cook	Start cooking in Cook mode
start_defrost	Start defrosting in Defrost mode
start_recipe	Start cooking in Recipe mode
init_low_power_control	CTS2SL for low-power measurement initial settings
base_line_setting_method1	CTS2SL baseline settings
enter_standby_mode	Software standby mode transition
enter_normal_mode	Normal operation mode transition
check_state_normal_mode	Touch judgement in normal operation mode
touch_judge	Touch judgement

4.4.7 Function Specifications

The following shows function specifications that are used in this sample program.

[Function name] main

Outline	Main process
Header	None
Declaration	void main (void)
Description	Initializes peripheral functions and controls touch keys and LCD.
Arguments	None
Return value	None
Remarks	None

[Function name] GUI_Init

Outline	Initializing emWin
Header	GUI.h
Declaration	void GUI_Init (void)
Description	Initializes emWin internal data structures and variables.
Arguments	None
Return value	None
Remarks	None

[Function name] R_CMT_CreatePeriodic

Outline	CMT counting start
Header	r_cmt_rx_if.h
Declaration	void R_CMT_CreatePeriodic (uint32_t frequency_hz, void (* callback)(void * pdata), uint32_t * channel)
Description	This function detects an unused CMT channel, configures it for the requested frequency, associates a user callback function with the timer's interrupt, and powers up and starts the timer.
Arguments	None
Return value	None
Remarks	None

[Function name] change_screen

Outline	LCD screen update
Header	LCD_custom_func.h
Declaration	void change_screen (void)
Description	Updates the LCD screen by touch operation.
Arguments	None
Return value	None
Remarks	None

[Function name] slide_func

Outline	Processing when "2" button is touched, or when the "2" button is pressed and held.
Header	LCD_custom_func.h
Declaration	void slide_func (void)
Description	When operating when "2" button is touched, or when the "2" button is pressed and held, processing according to the screen being displayed.
Arguments	None
Return value	None
Remarks	None

[Function name] select_pushed_func

Outline	Processing when "1" button is touched
Header	LCD_custom_func.h
Declaration	void select_pushed_func (void)
Description	When the "1" button is touched, processing according to the screen being displayed.
Arguments	None
Return value	None
Remarks	None

[Function name] home_pushed_func

Outline	Processing when "1" and "2" buttons are pressed and held
Header	LCD_custom_func.h
Declaration	void home_pushed_func (void)
Description	When the "1" "2" buttons are pressed and held, processing according to the screen being displayed.
Arguments	None
Return value	None
Remarks	None

[Function name] start_pushed_func

Outline	Processing when "1" button is touched
Header	LCD_custom_func.h
Declaration	void start_pushed_func (void)
Description	When "2" button is touched, processing according to the screen being displayed.
Arguments	None
Return value	None
Remarks	None

[Function name] countdown_func

Outline	Processing the countdown
Header	LCD_custom_func.h
Declaration	void countdown_func (void)
Description	Processing screen updates and time management during countdown on the cooking screen.
Arguments	None
Return value	None
Remarks	None

[Function name] slide_icons

Outline	Processing move to cursor for menu screens and mode selection screens for Cook, Defrost and Recipe
Header	LCD_custom_func.h
Declaration	void slide_icons (void)
Description	The cursor on the menu screen and the mode selection screen for Cook, Defrost, and Recipe can be moved according to the 2-button tap, press and hold operation.
Arguments	None
Return value	None
Remarks	None

[Function name] setting_cook

Outline	Setting the number of watts and seconds in Cook mode
Header	LCD_custom_func.h
Declaration	void setting_cook (void)
Description	Setting the number of watts and seconds in Cook mode with the 2-button tap, press and hold operation.
Arguments	None
Return value	None
Remarks	None

[Function name] setting_defrost

Outline	Setting the level of defrosting and the number of grams in Defrost mode
Header	LCD_custom_func.h
Declaration	void setting_defrost (void)
Description	Setting the level of defrosting and the number of grams in Defrost mode with the 2-button tap, press and hold operation.
Arguments	None
Return value	None
Remarks	None

[Function name] setting_recipe

Outline	Setting the number of cupcakes in Recipe mode
Header	LCD_custom_func.h
Declaration	void setting_recipe (void)
Description	Setting the number of cupcakes in Recipe mode with the 2-button tap, press and hold operation.
Arguments	None
Return value	None
Remarks	None

[Function name] mode_select_enter

Outline	Change the mode and display the LCD screen according to the mode
Header	LCD_custom_func.h
Declaration	void mode_select_enter (void)
Description	When the "1" button is touched, processing displays the LCD screen for mode change.
Arguments	None
Return value	None
Remarks	None

[Function name] change_target_cook

Outline	Change the setting target of the detail setting screen in Cook mode.
Header	LCD_custom_func.h
Declaration	void change_target_cook (void)
Description	Touch the "2" button to move the cursor
Arguments	None
Return value	None
Remarks	None

[Function name] change_target_defrost

Outline	Change the setting target of the detail setting screen in Defrost mode.
Header	LCD_custom_func.h
Declaration	void change_target_defrost (void)
Description	Touch the "2" button to move the cursor
Arguments	None
Return value	None
Remarks	None

[Function name] mode_change_menu

Outline	Move to the menu screen
Header	LCD_custom_func.h
Declaration	Void mode_change_menu (void)
Description	Move to the menu screen.
Arguments	None
Return value	None
Remarks	None

[Function name] start_cook

Outline	Start cooking in Cook mode
Header	LCD_custom_func.h
Declaration	void start_cook (void)
Description	Start cooking in Cook mode.
Arguments	None
Return value	None
Remarks	None

[Function name] start_defrost

Outline	Start defrosting in Defrost mode
Header	LCD_custom_func.h
Declaration	void start_defrost (void)
Description	Start defrosting in Defrost mode.
Arguments	None
Return value	None
Remarks	None

 [Function name] start_recipe

Outline Start cooking in Recipe mode
Header LCD_custom_func.h
Declaration void start_recipe (void)
Description Start cooking in Recipe mode.
Arguments None
Return value None
Remarks None

 [Function name] init_low_power_control

Outline CTSU2SL for low-power measurement initial settings
Header r_low_power_control.h
Declaration void init_low_power_control (void)
Description CTSU2SL for low-power measurement initial settings.
Arguments None
Return value None
Remarks None

 [Function name] base_line_setting_method1

Outline CTSU2SL baseline settings
Header r_low_power_control.h
Declaration void base_line_setting_method1 (void)
Description CTSU2SL baseline settings.
Arguments None
Return value None
Remarks None

 [Function name] enter_standby_mode

Outline Software standby mode transition
Header r_low_power_control.h
Declaration void enter_standby_mode (void)
Description Turn off LCD panel backlight and transition to software standby mode.
Arguments None
Return value None
Remarks None

 [Function name] enter_normal_mode

Outline Normal operation mode transition
Header r_low_power_control.h
Declaration void enter_normal_mode (void)
Description Turn on LCD panel backlight and transition to normal operation mode.
Arguments None
Return value None
Remarks None

[Function name] check_state_nomal_mode

Outline Touch judgement in normal operation mode
Header r_low_power_control.h
Declaration void check_state_nomal_mode (void)
Description Performs touch judgement in normal operation mode.
Arguments None
Return value None
Remarks None

[Function name] touch_judge

Outline Touch judgement
Header touch_func.h
Declaration void touch_judge (uint64_t button_status)
Description Performs touch judgement and sets the judgement result to a flag.
Arguments button_status
Return value None
Remarks None

4.4.8 ROM/RAM usage

ROM/RAM usage for this sample program is shown below.

Table 4-9 ROM usage

Size (KByte)	description
216	LCD Graphic data
140	emWin, LCD control
19	Touch (sleep)
17	demo program
19	other
Total 411KByte	MAX 512Kbyte (80% Used)

Table 4-10 RAM usage

Size (KByte)	description
51	bitmap work area
16	heap area
11	emWin work area
12	Color map
9	other
Total 99KByte	MAX 128KByte (77% Used)

5. Importing a Project

The sample program is distributed in e² studio project format. This section shows how to import a project into e² studio or CS+. After importing a project, check the build and debug settings.

5.1 Procedure in e² studio

To use sample programs in e² studio, follow the steps below to import them into e² studio. In projects managed by e² studio, do not use space codes, multibyte characters, and symbols such as "\$", "#", "%" in folder names or paths to them.

(Note that depending on the version of e² studio you are using, the interface may appear somewhat different from the screenshots below.)

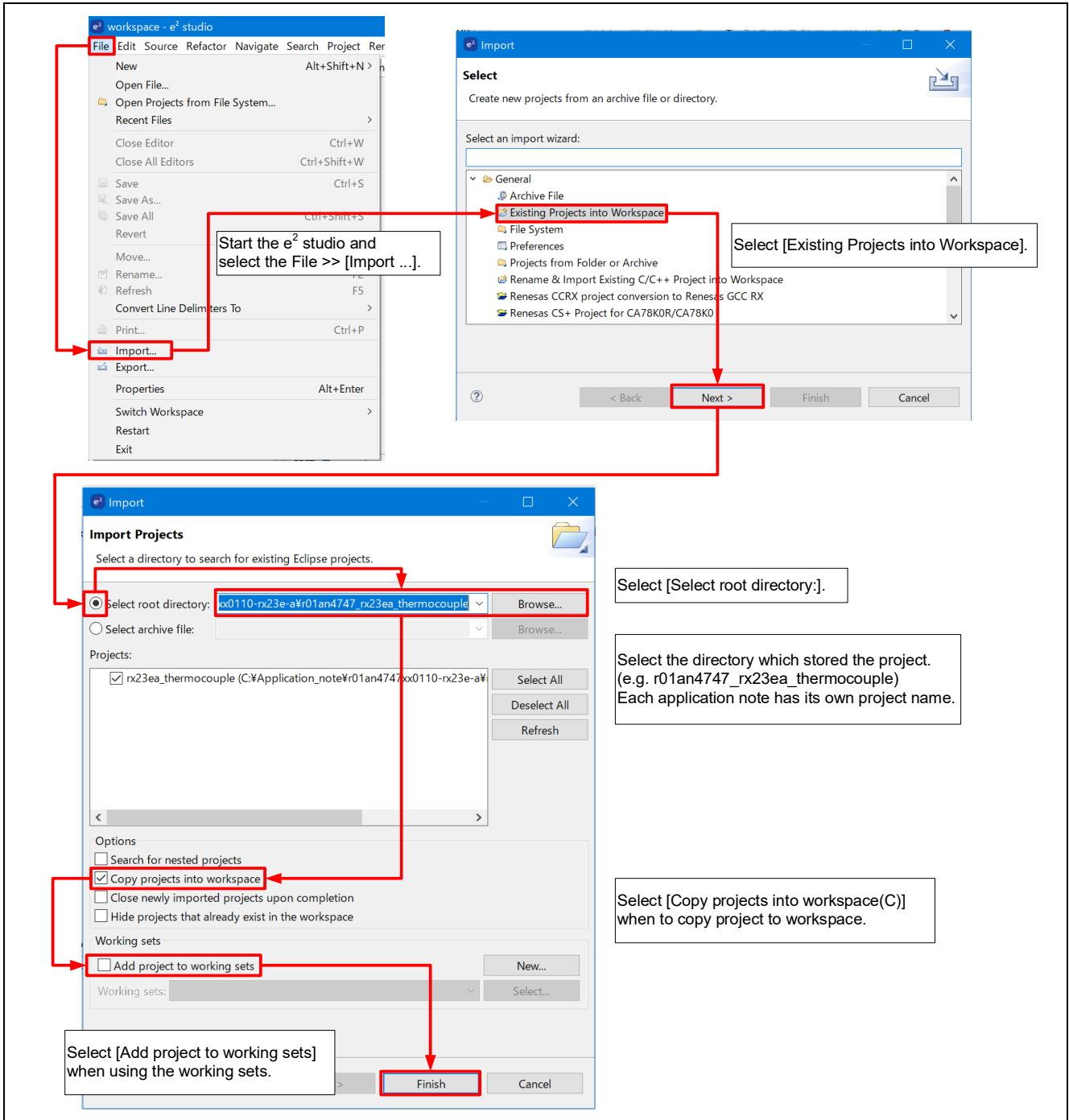

Figure 5-1 Import a Project into e² Studio

5.2 Procedure in CS+

To use sample programs in CS+, follow the steps below to import them into CS+. In projects managed by CS+, do not use space codes, multibyte characters, and symbols such as "\$", "#", "%" in folder names or paths to them.

(Note that depending on the version of CS+ you are using, the interface may appear somewhat different from the screenshots below.)

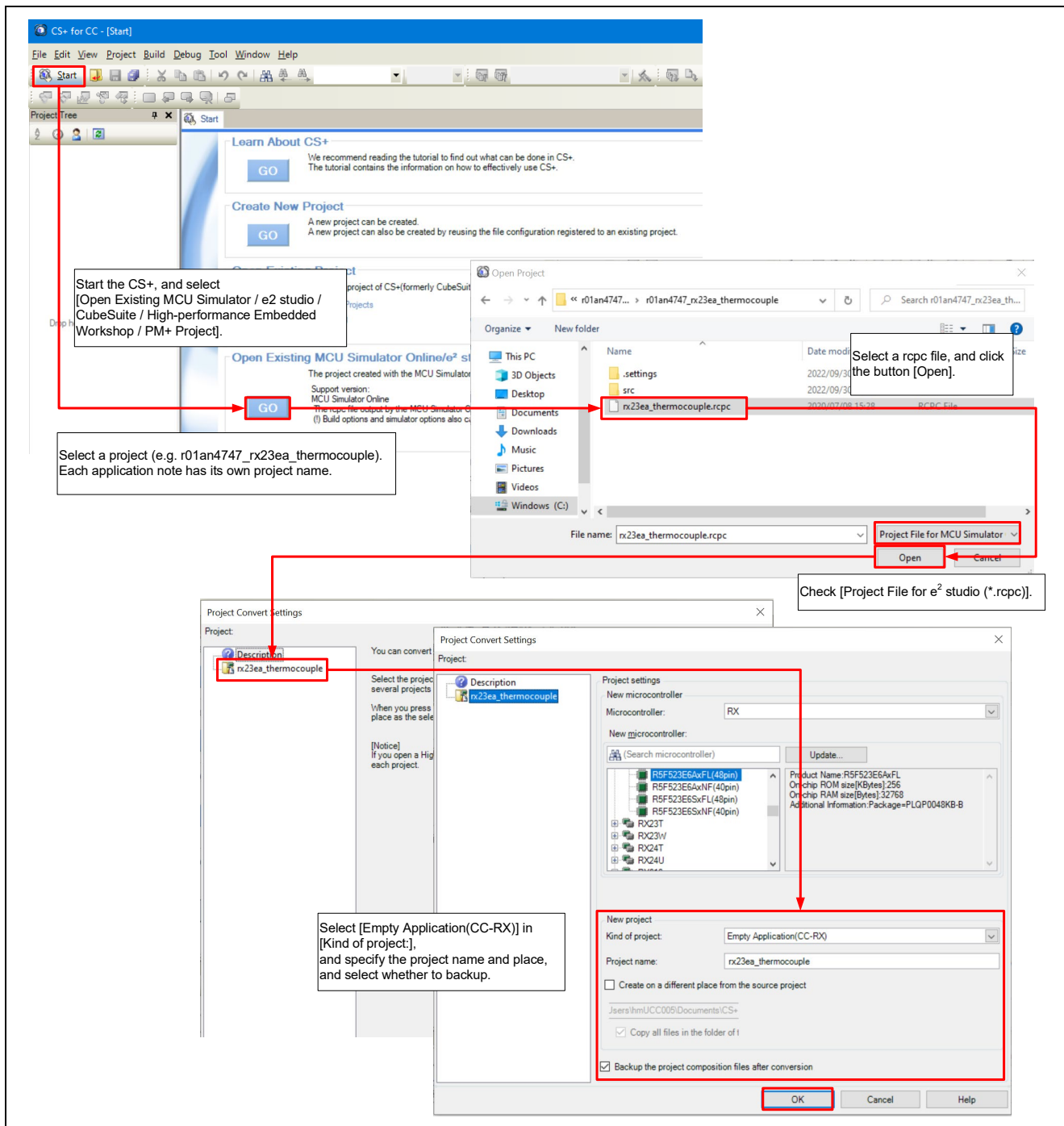

Figure 5-2 Import a Project into CS+

6. Start Demonstration

Disconnect the E2 Emulator Lite and turn on EK-RX261 v1 to start the demonstration program. This demonstration program assumes control of the display and settings of a microwave oven. Set the cooking conditions and recipe selections using the touch buttons while checking the LCD.

Hereinafter, touch buttons are described as buttons.



Figure 6-1 Demonstration screen and operation panel

6.1 Powered on EK-RX261 v1 and menu screen

When EK-RX261 v1 is powered on, the LCD panel displays the RX logo and RX261 features (initial screen) for approximately 5 seconds. When the display finishes, the sample program starts and becomes a menu screen.

And while the initial screen is displayed, can immediately move to the menu screen by touching one of the buttons.



Figure 6-2 Start of the demonstration

6.2 Menu screen

"Cook", "Defrost" or "Recipe" can be selected with the "2" button operation on the menu screen.

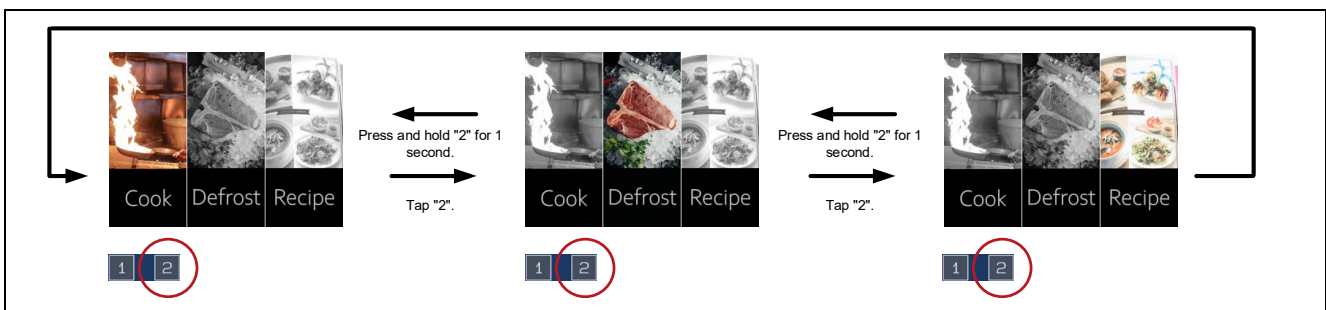

Figure 6-3 How to operate the menu screen

6.3 Cook setting

6.3.1 Move to mode selection screen

While "Cook" is selected on the menu screen, touching the "1" button can move to the Cook mode selection screen.

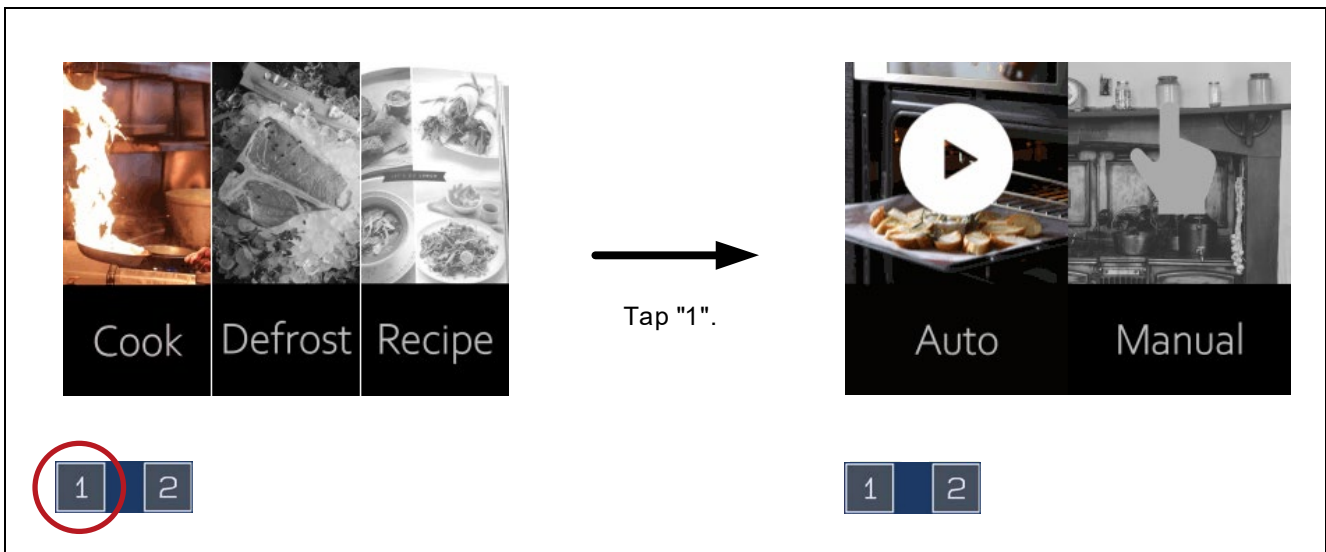

Figure 6-4 Move to the Cook mode selection screen

6.3.2 Select mode

While the Cook mode selection screen is displayed, "Auto" or "Manual" can be selected with the "2" button operation.

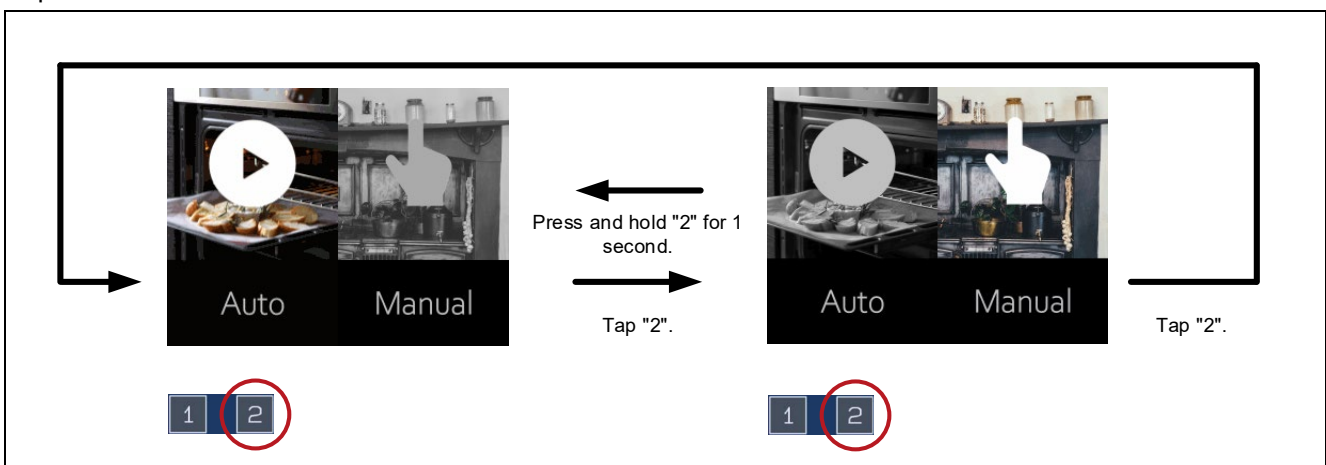

Figure 6-5 How to operate the Cook mode selection screen

6.3.3 Select Auto

While "Auto" is selected on the Cook mode selection screen, touching the "1" button can start cooking.

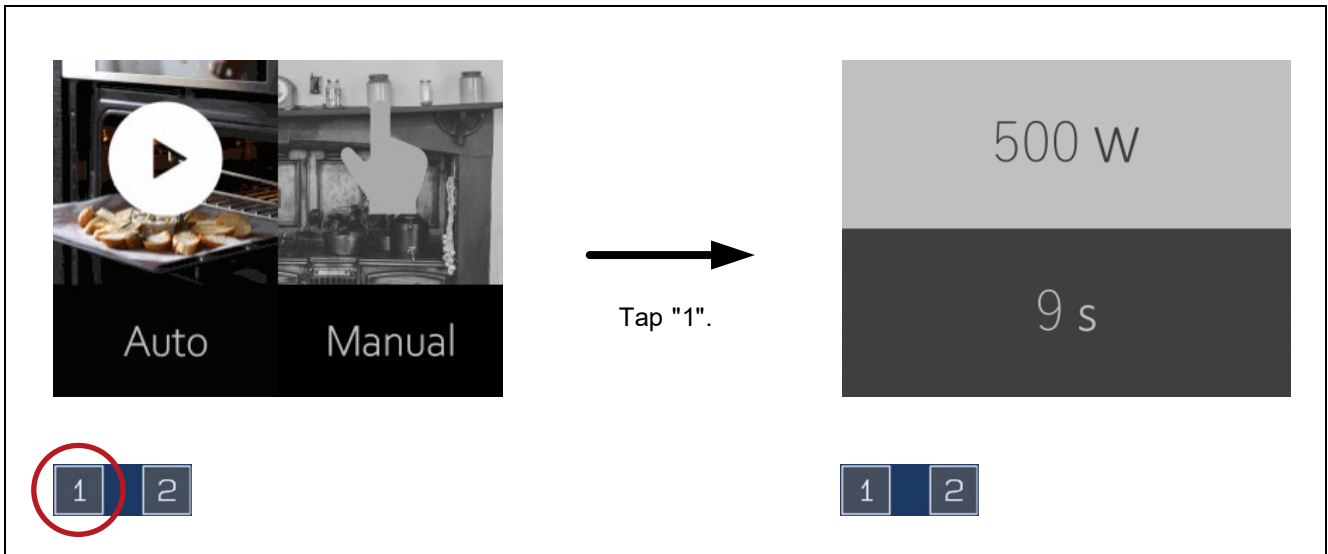

Figure 6-6 Start cooking in Auto mode

6.3.4 Select Manual

While "Manual" is selected on the Cook mode selection screen, touching the "1" button can move to the Cook detail setting screen.

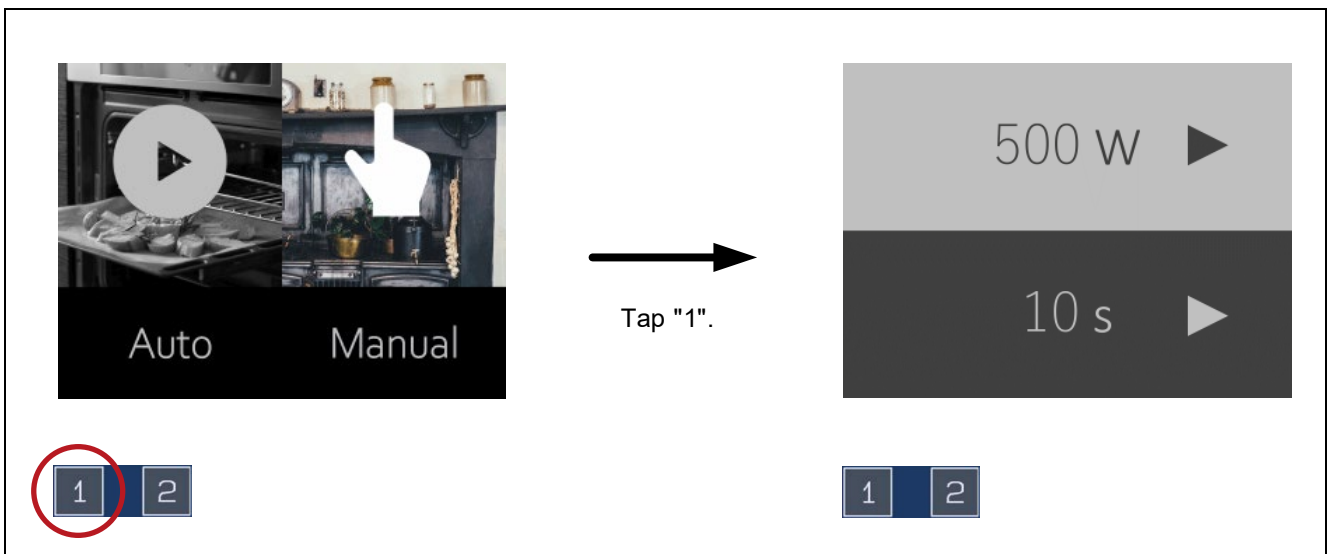

Figure 6-7 Move to the Cook detail setting screen

6.3.4.1 Set the number of watts

While the cursor is on the upper side, the number of watts can be set with the "2" button. "500W", "600W" and "700W" can be selected as the power level.

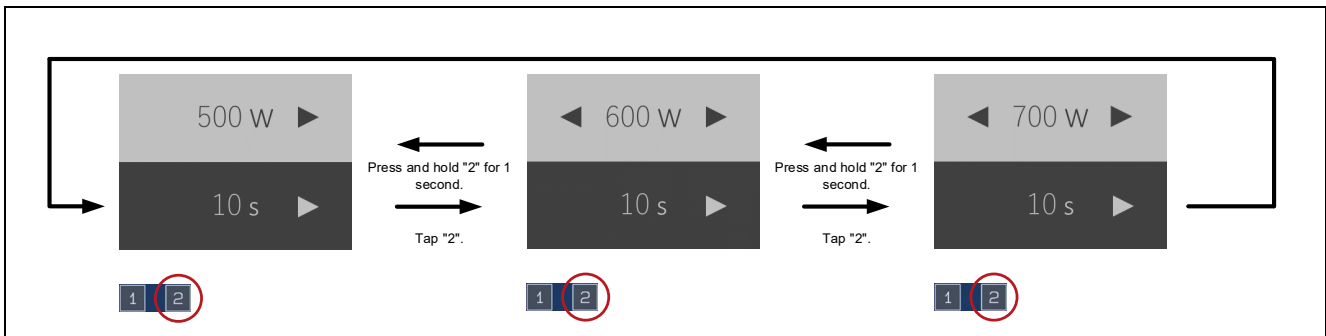

Figure 6-8 Setting the number of watts

6.3.4.2 Move the cursor

While the Cook detail setting screen is displayed, touching the "1" button can move the cursor. The item with a light-colored background is selected.

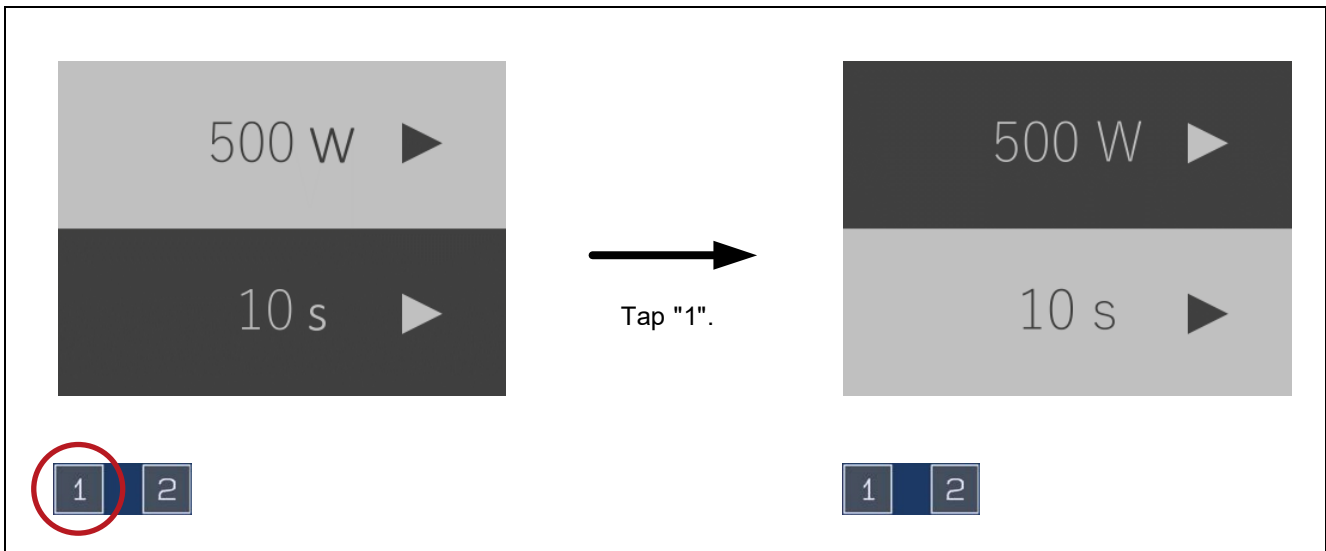

Figure 6-9 How to operate the cursor on the Cook detail setting screen

6.3.4.3 Set the number of seconds

While the cursor is on the lower side, the number of seconds can be set with the "2" button. "10s", "20s" and "30s", can be selected as the cooking time.

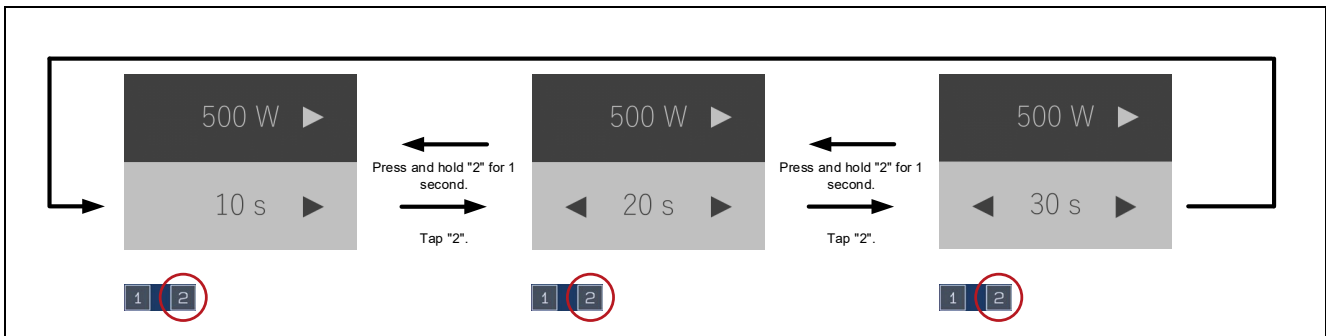

Figure 6-10 Setting the number of seconds

6.3.4.4 Start cooking

While the Cook detail setting screen is displayed and the cursor is on the lower side, touching the "1" button can start cooking.

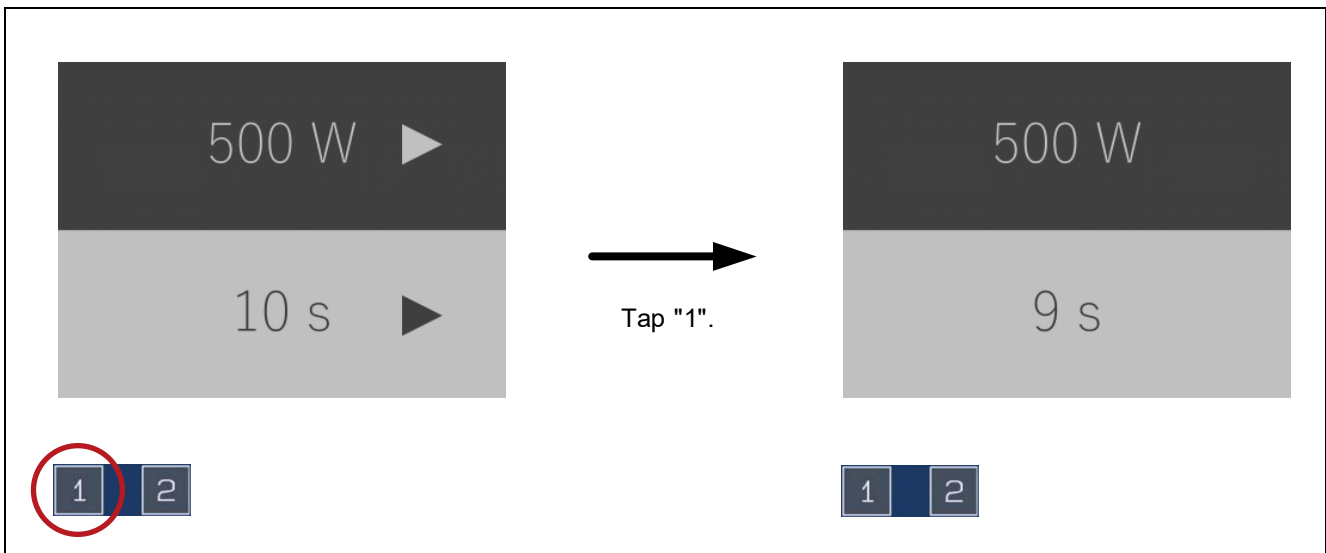

Figure 6-11 Start cooking in Manual mode

6.4 Defrost setting

6.4.1 Move to mode selection screen

While "Defrost" is selected on the menu screen, touching the "1" button can move to the Defrost mode selection screen.

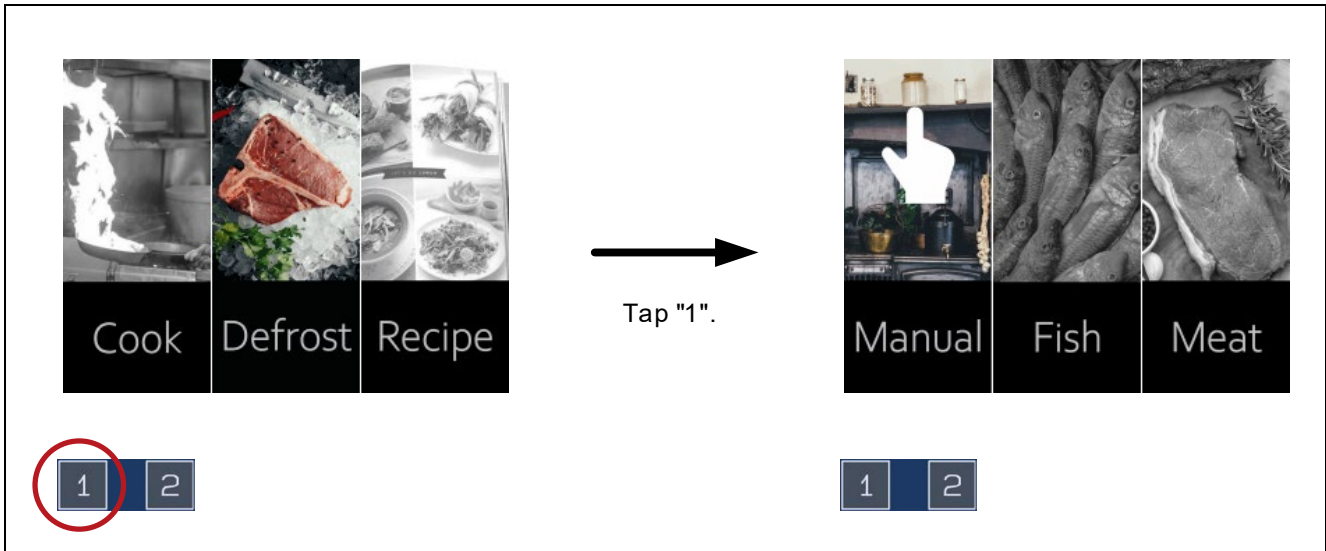

Figure 6-12 Move to the Defrost mode selection screen

6.4.2 Select mode

While the Defrost mode selection screen is displayed, "Manual", "Fish" or "Meat" can be selected with the "2" button operation.

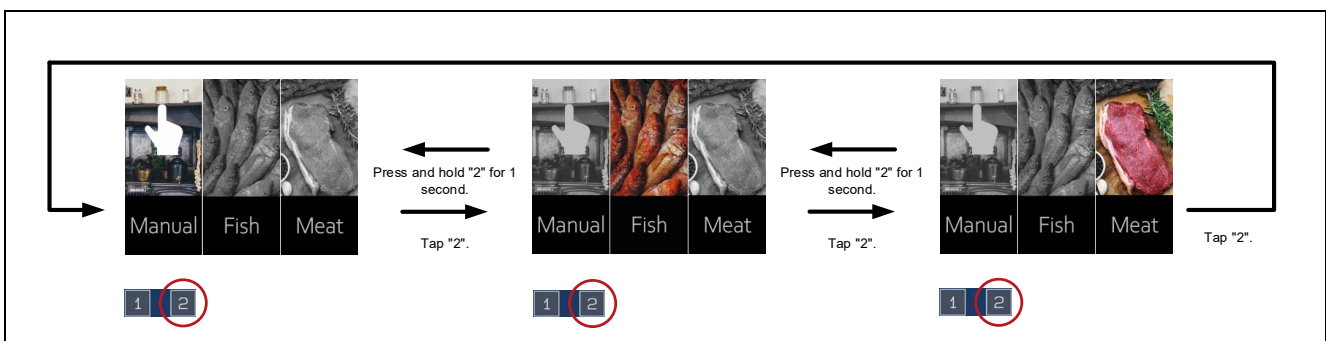

Figure 6-13 How to operate the Defrost mode selection screen

6.4.3 Select Manual

While "Manual" is selected on the Defrost mode selection screen, touching the "1" button can move to the Defrost detail setting screen.

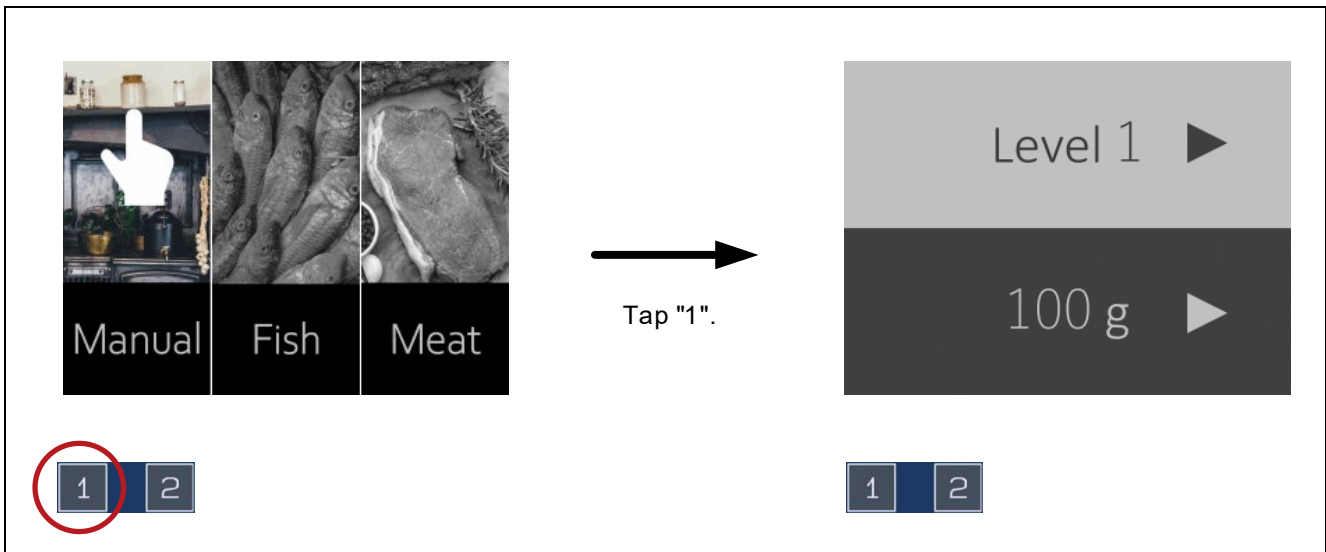

Figure 6-14 Move to the Defrost detail setting screen

6.4.3.1 Set the level of defrosting

While the cursor is on the upper side, the level of defrosting can be set with the "2" button. "Level1", "Level2" and "Level3" can be selected as the defrosting level.

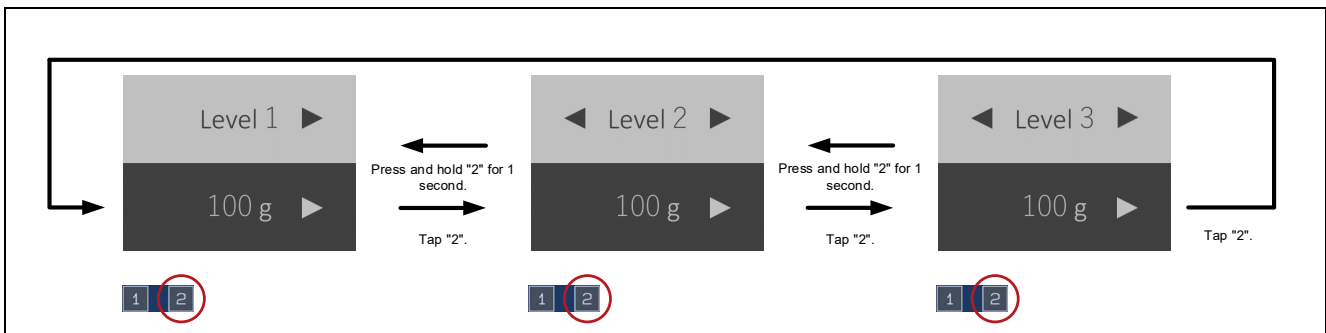

Figure 6-15 Setting the level of defrosting

6.4.3.2 Move the cursor

While the Defrost detail setting screen is displayed, touching the "1" button can move the cursor. The item with a light-colored background is selected.

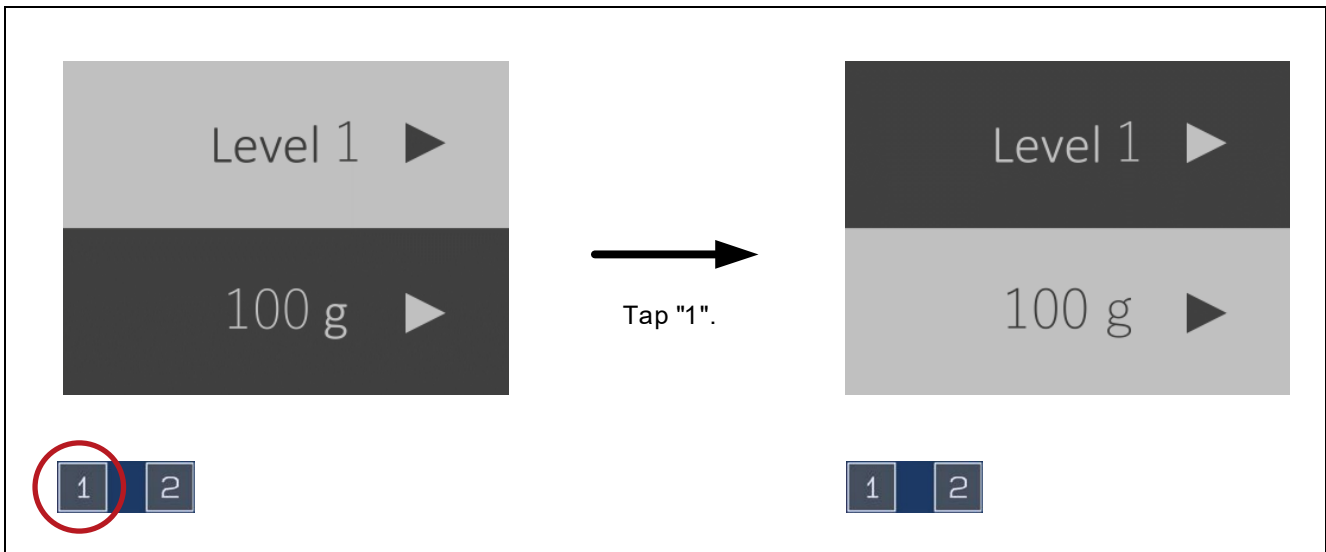

Figure 6-16 How to operate the cursor on the Defrost detail setting screen

6.4.3.3 Set the number of grams

While the cursor is on the lower side, the number of grams can be set with the "2" button. "100g", "200g" and "300g" can be selected as the defrosting amount.

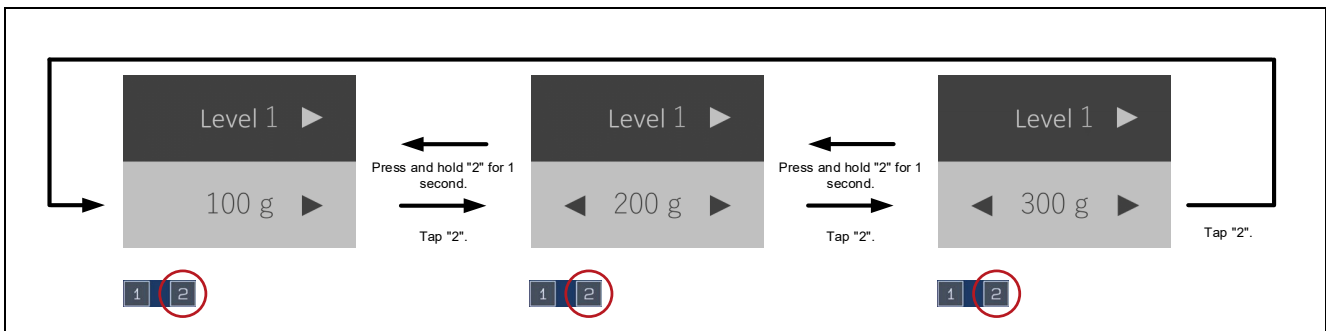

Figure 6-17 Setting the number of grams

6.4.3.4 Start defrosting

While the Defrost detail setting screen is displayed and the cursor is on the lower side, touching the "1" button can start defrosting.

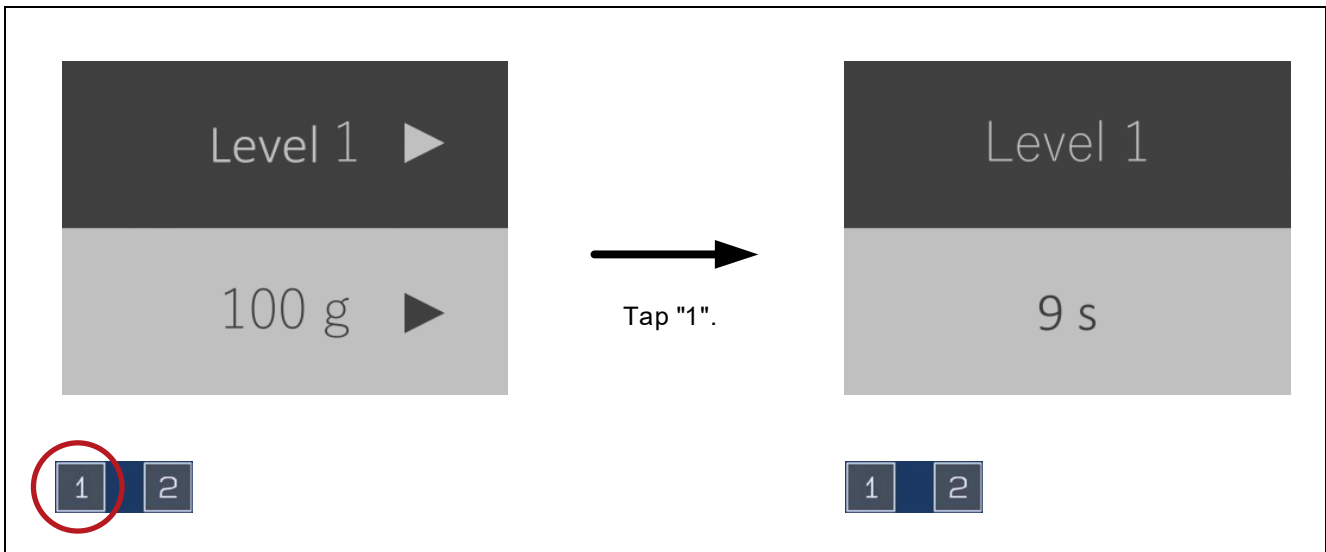

Figure 6-18 Start defrosting

6.4.4 Select Fish

While "Fish" is selected on the Defrost mode selection screen, touching the "1" button can start defrosting with the settings for "Fish".

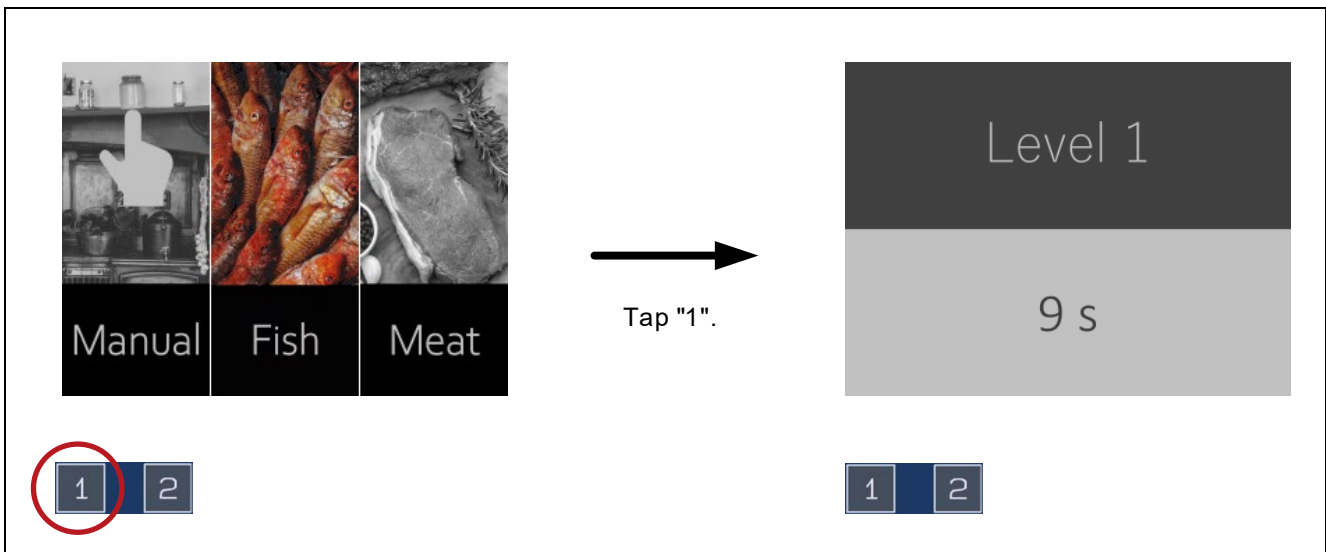

Figure 6-19 Start defrosting in Fish mode

6.4.5 Select Meat

While "Meat" is selected on the Defrost mode selection screen, touching the "1" button can start defrosting with the settings for "Meat".

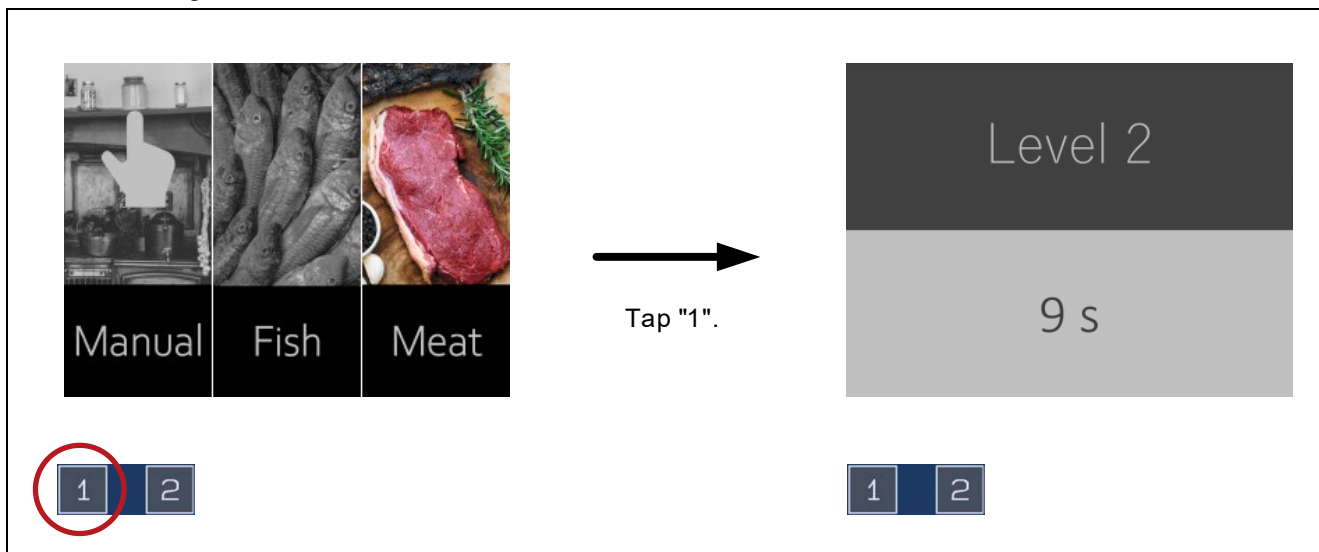

Figure 6-20 Start defrosting in Meat mode

6.5 Recipe setting

6.5.1 Move to recipe selection screen

While "Recipe" is selected on the menu screen, touching the "1" button can move to the Recipe selection screen.



Figure 6-21 Move to the Recipe selection screen

6.5.2 Select recipe

While the Recipe selection screen is displayed, "Beef Stew", "Garlic Shrimp" or "Cup Cake" can be selected with the "2" button operation.

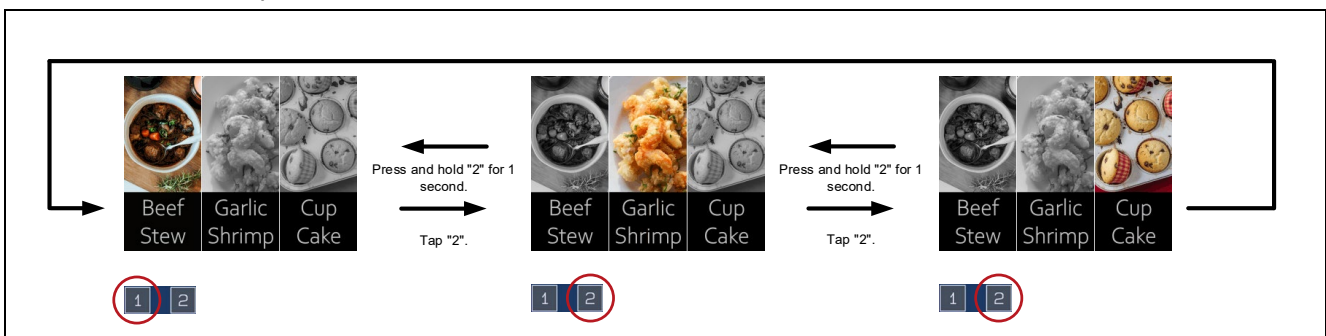

Figure 6-22 How to operate the Recipe selection screen

6.5.3 Select Beef Stew

While "Beef Stew" is selected on the Recipe selection screen, touching the "1" button can start cooking for the Settings for Beef Stew.

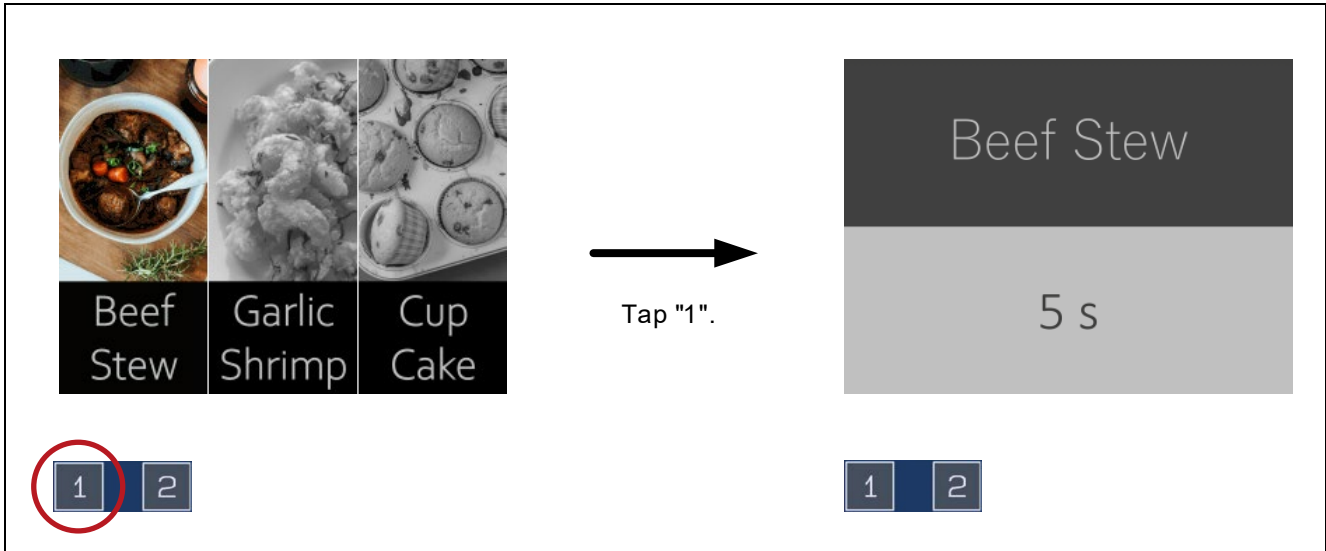

Figure 6-23 Start cooking in Beef Stew mode

6.5.4 Select Garlic Shrimp

While "Garlic Shrimp" is selected on the Recipe selection screen, touching the "1" button can start cooking for the Settings for Garlic Shrimp.

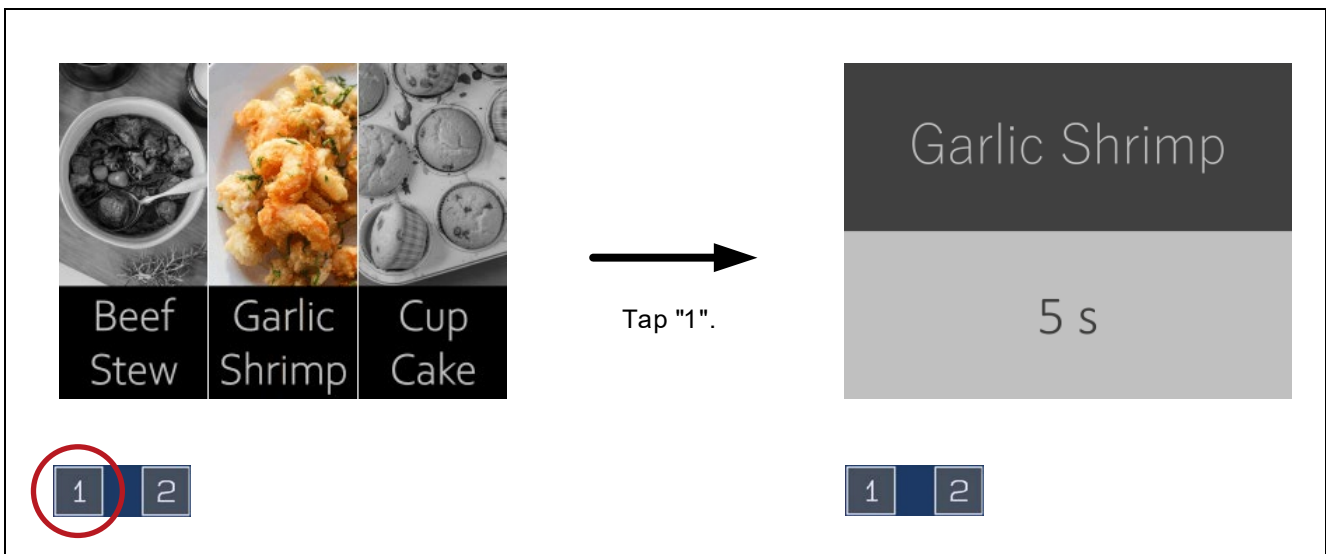

Figure 6-24 Start cooking in Garlic Shrimp mode

6.5.5 Select Cup Cake

While "Cup Cake" is selected on the Recipe selection screen, touching the "1" button can start cooking for the Settings for Cup Cake.

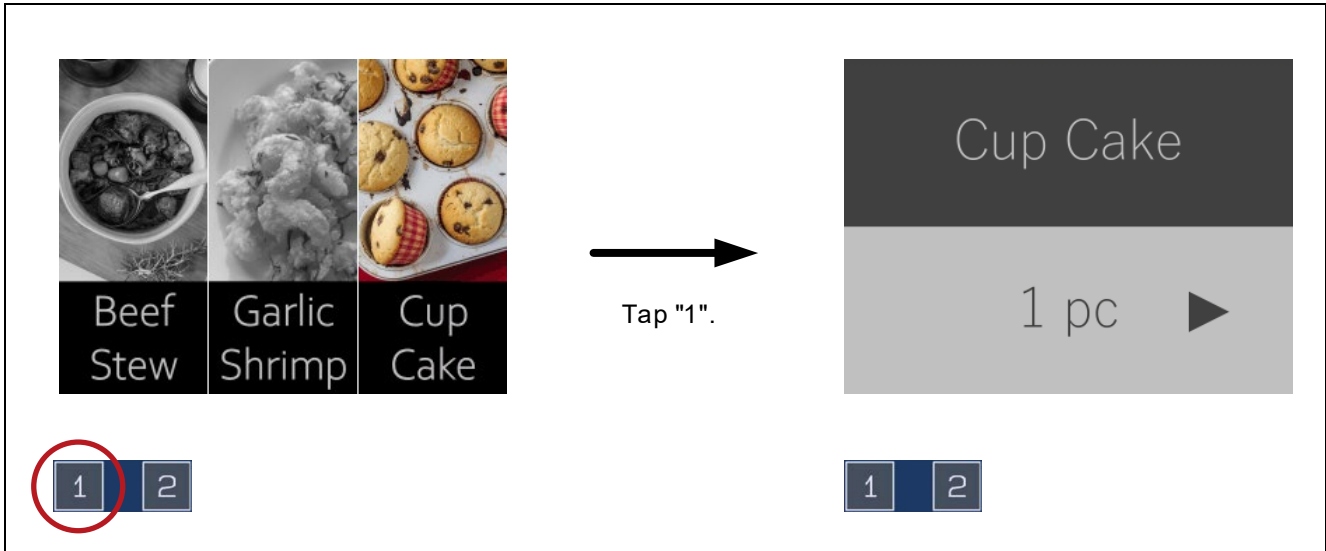

Figure 6-25 Move to the Cup Cake detail setting screen

6.5.5.1 Set the number of cupcakes

You can set the number of cupcakes with the "2" button. "1pc", "2pcs" and "3pcs" can be selected as the cooking amount.

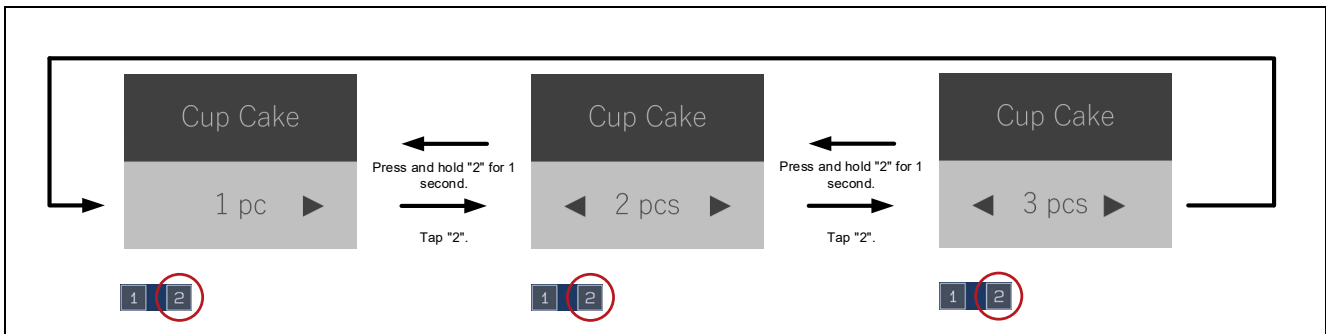

Figure 6-26 Setting the number of cupcakes

6.5.5.2 Start cooking

While the Cup Cake detail setting screen is displayed, touching the "1" button can start cooking.

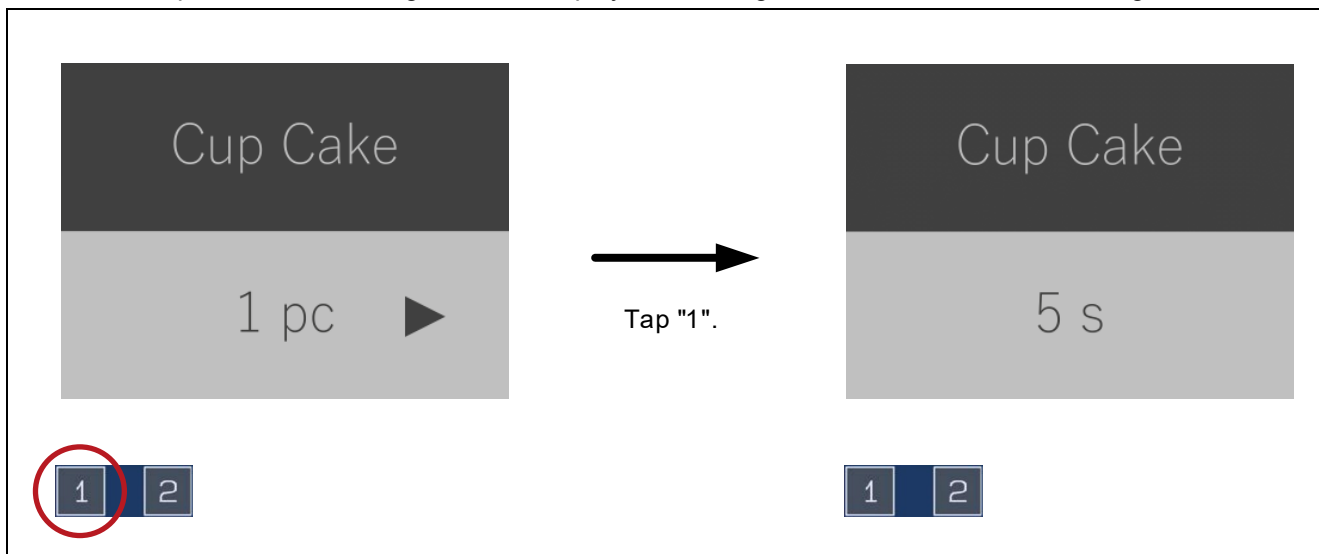

Figure 6-27 Start cooking in Cup Cake mode

6.6 Simultaneous press and hold both buttons 1 and 2

Pressing and holding buttons 1 and 2 simultaneously will returns to the menu screen from any screen.

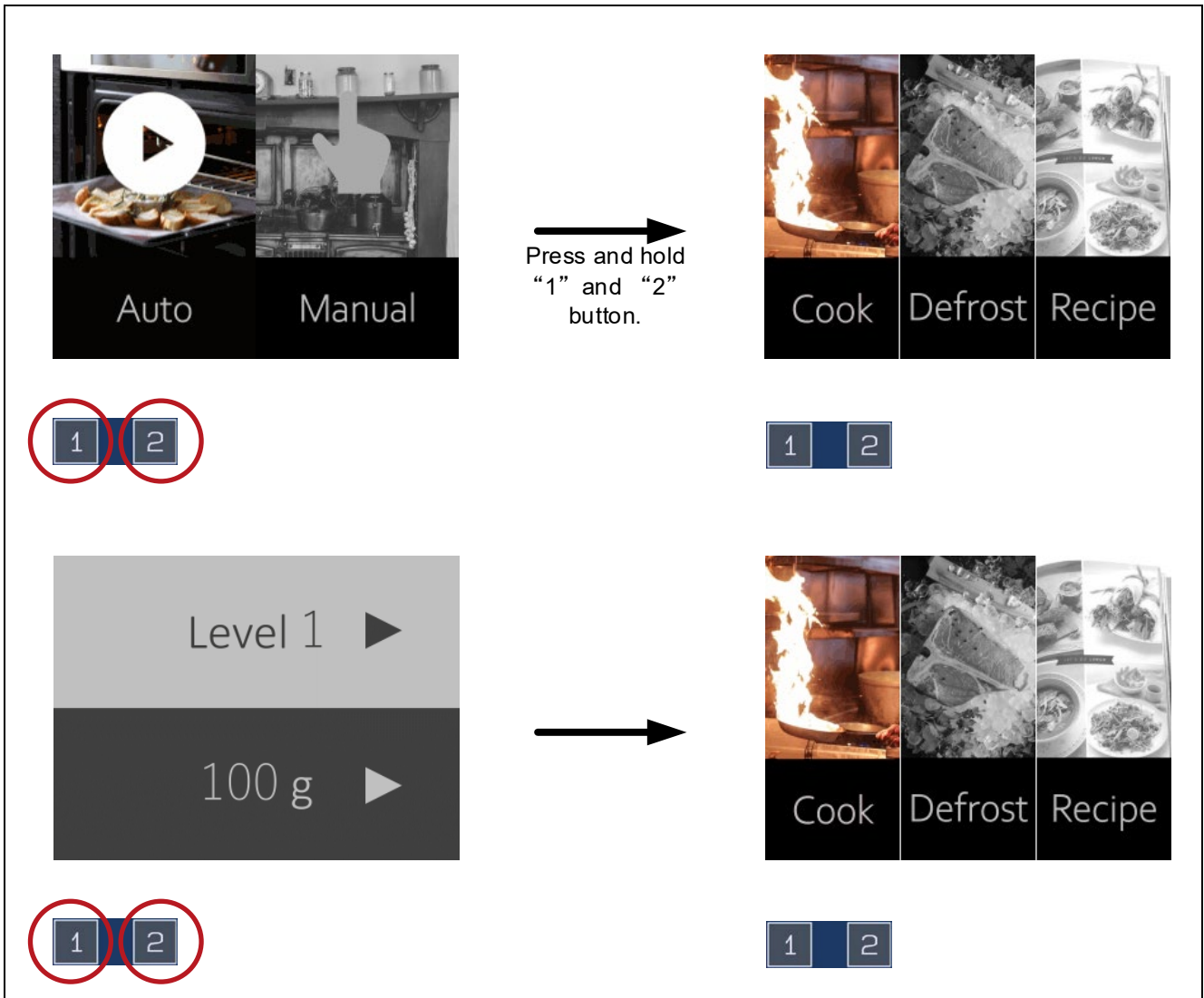

Figure 6-28 Example of press and hold "1" and "2" buttons operation

6.7 About the cooking completion screen

While completed cooking, the cooking completion screen is displayed for 3 seconds. After that, move to the menu screen automatically.

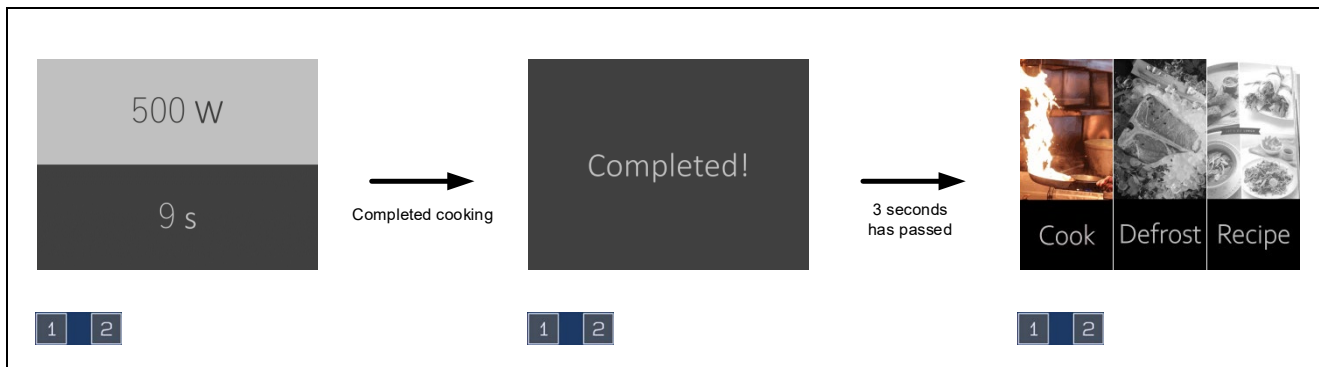

Figure 6-29 Example of cooking completion operation

6.8 Smart wakeup function

If no touch operation is performed for 10 seconds, the LCD is turned off and the RX261 transitions to software standby mode. For detail on Smart Wakeup, refer to “RX261 Group Smart Wakeup Solution”.

Long touch any button to return to the previous screen.

7. Reference Documents

- RX260 Group , RX261 Group User's Manual: Hardware (R01UH1045)
- RX261/RX260 Group Smart Wakeup Solution (R11AN0941)
- RX Family Using QE and FIT to Develop Capacitive Touch Applications (R01AN4516)
- RX Family QE for Display GUI Display Application Development Guide (R20AN0688)
- RX261 Group EK-RX261 v1 User's Manual (R20UT5351EG)

The latest version can be downloaded from the Renesas Electronics website.

All trademarks and registered trademarks are the property of their respective owners.

Revision History

Rev.	Date	Description	
		Page	Summary
1.00	Dec.20.24	—	First edition

General Precautions in the Handling of Microprocessing Unit and Microcontroller Unit Products

The following usage notes are applicable to all Microprocessing unit and Microcontroller unit products from Renesas. For detailed usage notes on the products covered by this document, refer to the relevant sections of the document as well as any technical updates that have been issued for the products.

1. Precaution against Electrostatic Discharge (ESD)

A strong electrical field, when exposed to a CMOS device, can cause destruction of the gate oxide and ultimately degrade the device operation. Steps must be taken to stop the generation of static electricity as much as possible, and quickly dissipate it when it occurs. Environmental control must be adequate. When it is dry, a humidifier should be used. This is recommended to avoid using insulators that can easily build up static electricity.

Semiconductor devices must be stored and transported in an anti-static container, static shielding bag or conductive material. All test and measurement tools including work benches and floors must be grounded. The operator must also be grounded using a wrist strap. Semiconductor devices must not be touched with bare hands. Similar precautions must be taken for printed circuit boards with mounted semiconductor devices.

2. Processing at power-on

The state of the product is undefined at the time when power is supplied. The states of internal circuits in the LSI are indeterminate and the states of register settings and pins are undefined at the time when power is supplied. In a finished product where the reset signal is applied to the external reset pin, the states of pins are not guaranteed from the time when power is supplied until the reset process is completed. In a similar way, the states of pins in a product that is reset by an on-chip power-on reset function are not guaranteed from the time when power is supplied until the power reaches the level at which resetting is specified.

3. Input of signal during power-off state

Do not input signals or an I/O pull-up power supply while the device is powered off. The current injection that results from input of such a signal or I/O pull-up power supply may cause malfunction and the abnormal current that passes in the device at this time may cause degradation of internal elements. Follow the guideline for input signal during power-off state as described in your product documentation.

4. Handling of unused pins

Handle unused pins in accordance with the directions given under handling of unused pins in the manual. The input pins of CMOS products are generally in the high-impedance state. In operation with an unused pin in the open-circuit state, extra electromagnetic noise is induced in the vicinity of the LSI, an associated shoot-through current flows internally, and malfunctions occur due to the false recognition of the pin state as an input signal become possible.

5. Clock signals

After applying a reset, only release the reset line after the operating clock signal becomes stable. When switching the clock signal during program execution, wait until the target clock signal is stabilized. When the clock signal is generated with an external resonator or from an external oscillator during a reset, ensure that the reset line is only released after full stabilization of the clock signal. Additionally, when switching to a clock signal produced with an external resonator or by an external oscillator while program execution is in progress, wait until the target clock signal is stable.

6. Voltage application waveform at input pin

Waveform distortion due to input noise or a reflected wave may cause malfunction. If the input of the CMOS device stays in the area between V_{IL} (Max.) and V_{IH} (Min.) due to noise, for example, the device may malfunction. Take care to prevent chattering noise from entering the device when the input level is fixed, and also in the transition period when the input level passes through the area between V_{IL} (Max.) and V_{IH} (Min.).

7. Prohibition of access to reserved addresses

Access to reserved addresses is prohibited. The reserved addresses are provided for possible future expansion of functions. Do not access these addresses as the correct operation of the LSI is not guaranteed.

8. Differences between products

Before changing from one product to another, for example to a product with a different part number, confirm that the change will not lead to problems. The characteristics of a microprocessing unit or microcontroller unit products in the same group but having a different part number might differ in terms of internal memory capacity, layout pattern, and other factors, which can affect the ranges of electrical characteristics, such as characteristic values, operating margins, immunity to noise, and amount of radiated noise. When changing to a product with a different part number, implement a system-evaluation test for the given product.

Notice

1. Descriptions of circuits, software and other related information in this document are provided only to illustrate the operation of semiconductor products and application examples. You are fully responsible for the incorporation or any other use of the circuits, software, and information in the design of your product or system. Renesas Electronics disclaims any and all liability for any losses and damages incurred by you or third parties arising from the use of these circuits, software, or information.
2. Renesas Electronics hereby expressly disclaims any warranties against and liability for infringement or any other claims involving patents, copyrights, or other intellectual property rights of third parties, by or arising from the use of Renesas Electronics products or technical information described in this document, including but not limited to, the product data, drawings, charts, programs, algorithms, and application examples.
3. No license, express, implied or otherwise, is granted hereby under any patents, copyrights or other intellectual property rights of Renesas Electronics or others.
4. You shall be responsible for determining what licenses are required from any third parties, and obtaining such licenses for the lawful import, export, manufacture, sales, utilization, distribution or other disposal of any products incorporating Renesas Electronics products, if required.
5. You shall not alter, modify, copy, or reverse engineer any Renesas Electronics product, whether in whole or in part. Renesas Electronics disclaims any and all liability for any losses or damages incurred by you or third parties arising from such alteration, modification, copying or reverse engineering.
6. Renesas Electronics products are classified according to the following two quality grades: "Standard" and "High Quality". The intended applications for each Renesas Electronics product depends on the product's quality grade, as indicated below.
 - "Standard": Computers; office equipment; communications equipment; test and measurement equipment; audio and visual equipment; home electronic appliances; machine tools; personal electronic equipment; industrial robots; etc.
 - "High Quality": Transportation equipment (automobiles, trains, ships, etc.); traffic control (traffic lights); large-scale communication equipment; key financial terminal systems; safety control equipment; etc.Unless expressly designated as a high reliability product or a product for harsh environments in a Renesas Electronics data sheet or other Renesas Electronics document, Renesas Electronics products are not intended or authorized for use in products or systems that may pose a direct threat to human life or bodily injury (artificial life support devices or systems; surgical implantations; etc.), or may cause serious property damage (space system; undersea repeaters; nuclear power control systems; aircraft control systems; key plant systems; military equipment; etc.). Renesas Electronics disclaims any and all liability for any damages or losses incurred by you or any third parties arising from the use of any Renesas Electronics product that is inconsistent with any Renesas Electronics data sheet, user's manual or other Renesas Electronics document.
7. No semiconductor product is absolutely secure. Notwithstanding any security measures or features that may be implemented in Renesas Electronics hardware or software products, Renesas Electronics shall have absolutely no liability arising out of any vulnerability or security breach, including but not limited to any unauthorized access to or use of a Renesas Electronics product or a system that uses a Renesas Electronics product. RENESAS ELECTRONICS DOES NOT WARRANT OR GUARANTEE THAT RENESAS ELECTRONICS PRODUCTS, OR ANY SYSTEMS CREATED USING RENESAS ELECTRONICS PRODUCTS WILL BE INVULNERABLE OR FREE FROM CORRUPTION, ATTACK, VIRUSES, INTERFERENCE, HACKING, DATA LOSS OR THEFT, OR OTHER SECURITY INTRUSION ("Vulnerability Issues"). RENESAS ELECTRONICS DISCLAIMS ANY AND ALL RESPONSIBILITY OR LIABILITY ARISING FROM OR RELATED TO ANY VULNERABILITY ISSUES. FURTHERMORE, TO THE EXTENT PERMITTED BY APPLICABLE LAW, RENESAS ELECTRONICS DISCLAIMS ANY AND ALL WARRANTIES, EXPRESS OR IMPLIED, WITH RESPECT TO THIS DOCUMENT AND ANY RELATED OR ACCOMPANYING SOFTWARE OR HARDWARE, INCLUDING BUT NOT LIMITED TO THE IMPLIED WARRANTIES OF MERCHANTABILITY, OR FITNESS FOR A PARTICULAR PURPOSE.
8. When using Renesas Electronics products, refer to the latest product information (data sheets, user's manuals, application notes, "General Notes for Handling and Using Semiconductor Devices" in the reliability handbook, etc.), and ensure that usage conditions are within the ranges specified by Renesas Electronics with respect to maximum ratings, operating power supply voltage range, heat dissipation characteristics, installation, etc. Renesas Electronics disclaims any and all liability for any malfunctions, failure or accident arising out of the use of Renesas Electronics products outside of such specified ranges.
9. Although Renesas Electronics endeavors to improve the quality and reliability of Renesas Electronics products, semiconductor products have specific characteristics, such as the occurrence of failure at a certain rate and malfunctions under certain use conditions. Unless designated as a high reliability product or a product for harsh environments in a Renesas Electronics data sheet or other Renesas Electronics document, Renesas Electronics products are not subject to radiation resistance design. You are responsible for implementing safety measures to guard against the possibility of bodily injury, injury or damage caused by fire, and/or danger to the public in the event of a failure or malfunction of Renesas Electronics products, such as safety design for hardware and software, including but not limited to redundancy, fire control and malfunction prevention, appropriate treatment for aging degradation or any other appropriate measures. Because the evaluation of microcomputer software alone is very difficult and impractical, you are responsible for evaluating the safety of the final products or systems manufactured by you.
10. Please contact a Renesas Electronics sales office for details as to environmental matters such as the environmental compatibility of each Renesas Electronics product. You are responsible for carefully and sufficiently investigating applicable laws and regulations that regulate the inclusion or use of controlled substances, including without limitation, the EU RoHS Directive, and using Renesas Electronics products in compliance with all these applicable laws and regulations. Renesas Electronics disclaims any and all liability for damages or losses occurring as a result of your noncompliance with applicable laws and regulations.
11. Renesas Electronics products and technologies shall not be used for or incorporated into any products or systems whose manufacture, use, or sale is prohibited under any applicable domestic or foreign laws or regulations. You shall comply with any applicable export control laws and regulations promulgated and administered by the governments of any countries asserting jurisdiction over the parties or transactions.
12. It is the responsibility of the buyer or distributor of Renesas Electronics products, or any other party who distributes, disposes of, or otherwise sells or transfers the product to a third party, to notify such third party in advance of the contents and conditions set forth in this document.
13. This document shall not be reprinted, reproduced or duplicated in any form, in whole or in part, without prior written consent of Renesas Electronics.
14. Please contact a Renesas Electronics sales office if you have any questions regarding the information contained in this document or Renesas Electronics products.

(Note1) "Renesas Electronics" as used in this document means Renesas Electronics Corporation and also includes its directly or indirectly controlled subsidiaries.

(Note2) "Renesas Electronics product(s)" means any product developed or manufactured by or for Renesas Electronics.

(Rev.5.0-1 October 2020)

Corporate Headquarters

TOYOSU FORESIA, 3-2-24 Toyosu,
Koto-ku, Tokyo 135-0061, Japan
www.renesas.com

Trademarks

Renesas and the Renesas logo are trademarks of Renesas Electronics Corporation. All trademarks and registered trademarks are the property of their respective owners.

Contact information

For further information on a product, technology, the most up-to-date version of a document, or your nearest sales office, please visit:
www.renesas.com/contact/.