

RZ/N2H Group

A-format sample program

Introduction

This application note describes a sample program for acquiring and displaying information from an encoder conforming to the A-format™ Version 2.0 communications protocol specification ("A-format™ V2 specification") by using the Encoder Interface of the RZ/N2H.

The major features of the program are listed below.

- Supports A-format™ V2 command codes.
- Capable of acquiring angle information, etc. from an encoder conforming to the A-format™ V2 specification (MAR-M50A from Nikon).

Target Device

RZ/N2H

Table of Contents

1. Specifications	4
2. Operating Environment.....	5
3. Peripheral Functions.....	6
3.1 Pins.....	6
4. Software	8
4.1 A-format Driver Function	8
4.2 File Structure	8
4.3 Functions.....	8
4.4 Specifications of API Functions.....	9
4.4.1 R_A_AS_Open.....	9
4.4.2 R_A_AS_Close.....	9
4.4.3 R_A_AS_GetVersion.....	10
4.4.4 R_A_AS_Control	10
4.5 Specification of User-Defined Functions	14
4.5.1 a_as_txerr_callback	14
4.5.2 a_as_rxset_callback.....	15
4.5.3 a_as_rxend_callback.....	16
4.5.4 a_as_elctimer_callback.....	17
4.6 Interrupt Handlers.....	19
4.6.1 a_as0_int_isr	19
4.6.2 a_as1_int_isr	19
4.6.3 a_as2_int_isr	19
4.6.4 a_as3_int_isr	19
4.6.5 a_as4_int_isr	19
4.6.6 a_as5_int_isr	20
4.6.7 a_as6_int_isr	20
4.6.8 a_as7_int_isr	20
4.6.9 a_as9_int_isr	20
4.6.10 a_as10_int_isr	20
4.6.11 a_as11_int_isr	21
4.6.12 a_as13_int_isr	21
4.6.13 a_as14_int_isr	21
4.6.14 a_as_err_isr.....	21
4.7 Interrupt	22
4.8 Constants/Error Codes.....	23
4.9 Fixed-Width Integer	26
4.10 Structure/Unions/Enumerated Types	26
4.10.1 Structures	26

4.10.2 Unions	30
4.10.3 Enumerated Types	30
4.11 Sample Program.....	31
4.11.1 Operation Overview.....	31
4.11.2 Functions Used in the Sample Program	33
4.11.3 Specifications of Sample Program Functions	34
4.11.4 Variables Used in the Sample Program	38
4.11.5 Constants Used in the Sample Program.....	38
4.11.6 Flowchart of Main Process	39
4.11.7 Operation Sequence	46
4.11.8 Console Commands	50
5. Sample Code.....	52
Revision History.....	53

1. Specifications

Table 1.1 lists the peripheral functions to be used and their applications. Figure 1.1 shows the operating environment when the sample code is being executed.

Table 1.1 Peripheral Functions and Applications

Peripheral Module	Application
A-format communications controller (AFMT)	Communications with the A-format V2 compliant encoder.
Interrupt controller (ICU)	Controls the AFMT interrupts.
General PWM Timer (GPT) Unit 0 Channel 0	Generates events at fixed intervals for input to the ELC.
Event link controller (ELC)	Makes the link between events output from unit 0 channel 0 of the GPT and the AFMT module.
Serial communication interface (SCI) UART	Asynchronous communications of the SCI are used for COM port communications by using USB interface. It is used for console interface of the sample program.

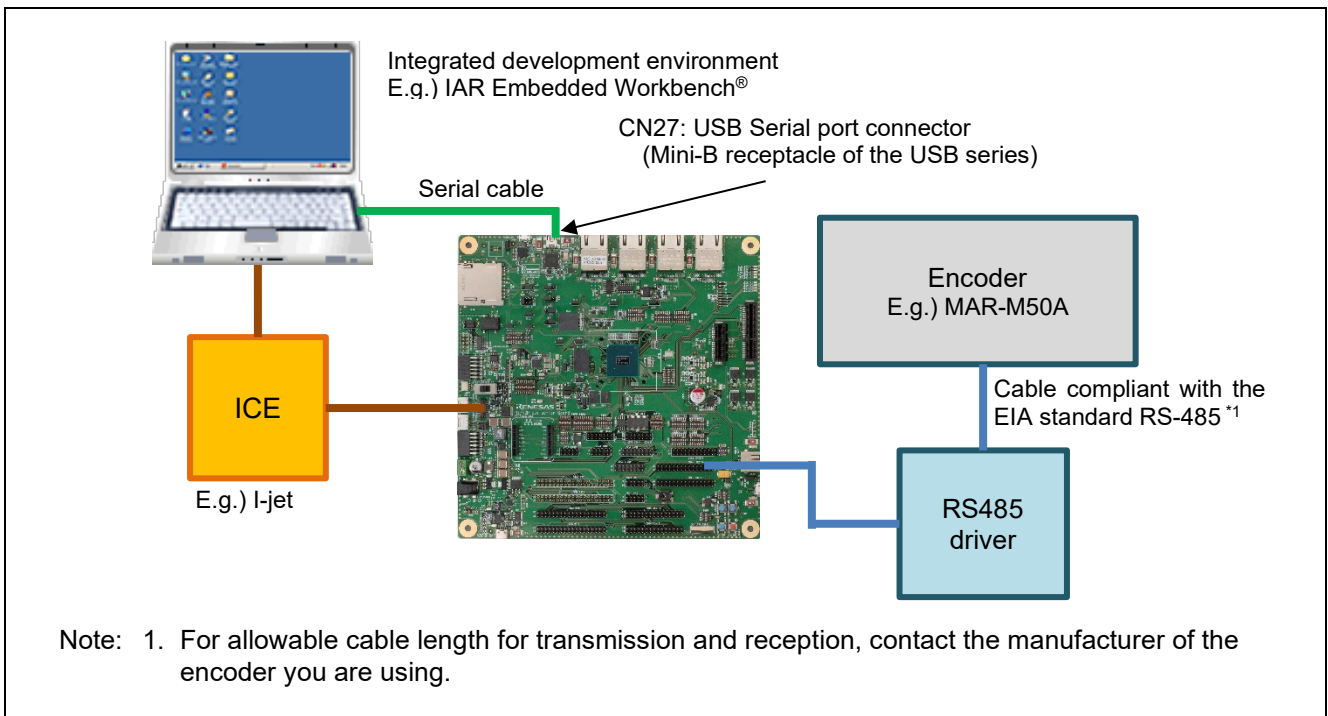

Figure 1.1 Operating Environment

2. Operating Environment

The sample code covered in this application note is for the environment below.

Table 2.1 Operating Environment

Item		Description
MCU		RZ/N2H
Operating frequency *1	CR52 ver.	CPUCLK = 1000 MHz (Cortex®-R52 CPU0)
	CA55 ver.	CPUCLK = 1200 MHz (Cortex®-A55 Core0)
Operating voltage		0.8 V (Core) / 1.1 V (DDR) / 1.8 V (PLL, etc.) / 3.3 V (I/O)
Integrated development environment *2		IAR Systems IAR Embedded Workbench® for Arm® RENESAS e ² studio
Board		RZ/N2H Evaluation Board (RTK9RZN2Hxxxxxxxx)
Devices (function to be used on the board)		None

- Note: 1. This sample program has a CR52 version that runs on the CPU core Cortex®-R52 and a CA55 version that runs on the CPU core Cortex®-A55. CR52 ver. and CA55 ver. are descriptions of the respective version.
2. Refer to the RZ/N2H Group Encoder I/F A-format sample program Release Note to check the version number of the integrated development environment.

3. Peripheral Functions

The basics of the peripheral modules, operating modes, and registers are described in the “RZ/N2H Group User’s Manual: Hardware”

3.1 Pins

The pins used and their functions are listed in the table below. Channels AFMT8, AFMT12, and AFMT15 out of AFMT0 to AFMT15 have no assigned I/O ports. The remaining 13 channels are available to use.

Table 3.1 Pins Used and Their Functions

Channel	Port Name	I/O Port	Input /Output	Voltage Domain	Description
AFMT0	ENCIFDI00 (SDAT)	P14_5	Input	VDD33	Data input
	ENCIFDO00 (REQ)	P14_4	Output	VDD33	Data output
	ENCIFOE00 (D/R)	P14_3	Output	VDD33	Drive/receive control
AFMT1	ENCIFDI01 (SDAT)	P27_0	Input	VDD33	Data input
	ENCIFDO01 (REQ)	P26_7	Output	VDD33	Data output
	ENCIFOE01 (D/R)	P02_1	Output	VDD1833_5	Drive/receive control
AFMT2	ENCIFDI02 (SDAT)	P03_2	Input	VDD33	Data input
	ENCIFDO02 (REQ)	P03_1	Output	VDD33	Data output
	ENCIFOE02 (D/R)	P03_4	Output	VDD33	Drive/receive control
AFMT3	ENCIFDI03 (SDAT)	P13_3	Input	VDD1833_6	Data input
	ENCIFDO03 (REQ)	P13_2	Output	VDD1833_6	Data output
	ENCIFOE03 (D/R)	P13_1	Output	VDD1833_6	Drive/receive control
AFMT4	ENCIFDI04 (SDAT)	P10_5	Input	VDD33	Data input
	ENCIFDO04 (REQ)	P10_4	Output	VDD33	Data output
	ENCIFOE04 (D/R)	P10_3	Output	VDD33	Drive/receive control
AFMT5	ENCIFDI05 (SDAT)	P12_7	Input	VDD1833_6	Data input
	ENCIFDO05 (REQ)	P12_6	Output	VDD1833_6	Data output
	ENCIFOE05 (D/R)	P12_5	Output	VDD1833_6	Drive/receive control
AFMT6	ENCIFDI06 (SDAT)	P34_1	Input	VDD1833_3	Data input
	ENCIFDO06 (REQ)	P34_0	Output	VDD1833_3	Data output
	ENCIFOE06 (D/R)	P33_7	Output	VDD1833_3	Drive/receive control
AFMT7	ENCIFDI07 (SDAT)	P34_5	Input	VDD1833_3	Data input
	ENCIFDO07 (REQ)	P34_4	Output	VDD1833_3	Data output
	ENCIFOE07 (D/R)	P34_3	Output	VDD1833_3	Drive/receive control
AFMT8	ENCIFDI08 (SDAT)	-	-	-	N.A.
	ENCIFDO08 (REQ)	-	-	-	N.A.
	ENCIFOE08 (D/R)	-	-	-	N.A.
AFMT9	ENCIFDI09 (SDAT)	P29_4	Input	VDD1833_2	Data input
	ENCIFDO09 (REQ)	P29_3	Output	VDD1833_2	Data output
	ENCIFOE09 (D/R)	P29_2	Output	VDD1833_2	Drive/receive control
AFMT10	ENCIFDI10 (SDAT)	P30_0	Input	VDD1833_2	Data input
	ENCIFDO10 (REQ)	P29_7	Output	VDD1833_2	Data output
	ENCIFOE10 (D/R)	P29_6	Output	VDD1833_2	Drive/receive control
AFMT11	ENCIFDI11 (SDAT)	P30_4	Input	VDD1833_2	Data input
	ENCIFDO11 (REQ)	P30_3	Output	VDD1833_2	Data output
	ENCIFOE11 (D/R)	P30_2	Output	VDD1833_2	Drive/receive control

Channel	Port Name	I/O Port	Input /Output	Voltage Domain	Description
AFMT12	ENCIFDI12 (SDAT)	-	-	-	N.A.
	ENCIFDO12 (REQ)	-	-	-	N.A.
	ENCIFOE12 (D/R)	-	-	-	N.A.
AFMT13	ENCIFDI13 (SDAT)	P13_7	Input	VDD1833_6	Data input
	ENCIFDO13 (REQ)	P13_6	Output	VDD1833_6	Data output
	ENCIFOE13 (D/R)	P13_5	Output	VDD1833_6	Drive/receive control
AFMT14	ENCIFDI14 (SDAT)	P18_7	Input	VDD33	Data input
	ENCIFDO14 (REQ)	P18_6	Output	VDD33	Data output
	ENCIFOE14 (D/R)	P18_5	Output	VDD33	Drive/receive control
AFMT15	ENCIFDI15 (SDAT)	-	-	-	N.A.
	ENCIFDO15 (REQ)	-	-	-	N.A.
	ENCIFOE15 (D/R)	-	-	-	N.A.

4. Software

4.1 A-format Driver Function

The functions of the A-format driver are listed below.

- 1 Initial settings
- 2 Transmission of command codes
- 3 Acquisition of reception data

4.2 File Structure

For the file structure, refer to the release note for the RZ/N2H Group Encoder I/F A-format sample program.

4.3 Functions

The functions to be used are listed in the table below.

Table 4.1 List of Functions

Category	Function Name	Page
A-format driver API functions	R_A_AS_Open	9
	R_A_AS_Close	9
	R_A_AS_GetVersion	10
	R_A_AS_Control	10
User-defined functions	a_as_txerr_callback	14
	a_as_rxset_callback	15
	a_as_rxend_callback	16
	a_as_elctimer_callback	17
Interrupt handlers	a_as0_int_isr	19
	a_as1_int_isr	19
	a_as2_int_isr	19
	a_as3_int_isr	19
	a_as4_int_isr	19
	a_as5_int_isr	20
	a_as6_int_isr	20
	a_as7_int_isr	20
	a_as9_int_isr	20
	a_as10_int_isr	20
	a_as11_int_isr	21
	a_as13_int_isr	21
	a_as14_int_isr	21
	a_as_err_isr	21

4.4 Specifications of API Functions

4.4.1 R_A_AS_Open

R_A_AS_Open	
Synopsis	Starts controlling operation of the encoder.
Header	r_a_as_rzt2_if.h
Declaration	int32_t R_A_AS_Open(const int32_t id, r_a_as_info_t* p_info);
Description	This function is used for the following initial settings of the AFMT module. <ol style="list-style-type: none"> 1. Release A-format Interface from the module-stop state 2. Setting of the encoder interface 3. Setting of the communication parameters (for BRSEL register) 4. Setting for enabling interrupts.
Argument	id : Designates the ID code to be used. (It is defined in r_a_as_rzt2_dat.h.) R_A_AS0_ID : Specifies channel 0. R_A_AS1_ID : Specifies channel 1. : : R_A_AS15_ID : Specifies channel 15. Others : Setting is not allowed. p_info : Sets information about the encoder Designate the address of the structure r_a_as_info_t where encoder information is stored.
Return value	R_A_AS_SUCCESS: Normal termination R_A_AS_ERR_INVALID_ARG: Abnormal termination (the id or p_info member variable of the structure r_a_as_info_t is not available or not specified.) R_A_AS_ERR_ACCESS: Abnormal termination (already opened.)
Note	This function configures the encoder interface. If this function is executed after power for the encoder has been switched on, send CDF8 eight consecutive times to clear the status flag after executing this function. The channel 8, the channel 12, and the channel 15 are not available in this sample program. Calling this API function from within a callback function is not allowed.

4.4.2 R_A_AS_Close

R_A_AS_Close	
Synopsis	Stops controlling operation of the encoder
Header	r_a_as_rzt2_if.h
Declaration	int32_t R_A_AS_Close(const int32_t id);
Description	This function stops controlling operation of the encoder on the designated channel.
Argument	id : Designates the ID code to be used. (It is defined in r_a_as_rzt2_dat.h.) R_A_AS0_ID : Specifies Channel 0. R_A_AS1_ID : Specifies Channel 1. : : R_A_AS15_ID : Specifies Channel 15. Others : Setting is not allowed.
Return Value	R_A_AS_SUCCESS: Normal termination R_A_AS_ERR_INVALID_ARG: Abnormal termination (the id is not available or not specified.) R_A_AS_ERR_ACCESS: Abnormal termination (a request is being transmitted.)
Note	The channel 8, the channel 12, and the channel 15 are not available in this sample program. Calling this API function from within a callback function is not allowed.

4.4.3 R_A_AS_GetVersion

R_A_AS_GetVersion	
Synopsis	Acquire the version number of the encoder interface driver.
Header	r_a_as_rzt2_if.h
Declaration	uint32_t R_A_AS_GetVersion(const r_a_as_type_t type);
Description	This function acquires the version number of the A-format driver.
Argument	type : Designates R_A_AS_A_FORMAT.
Return value	A major part of the version number is stored in the sixteen MSBs and the minor part of the version number is stored in the sixteen LSBs.
Supplement	If a type other than those listed above is stipulated, the returned value will be 0xFFFFFFFF.
Note	Calling this API function from within a callback function is not allowed.

4.4.4 R_A_AS_Control

R_A_AS_Control	
Synopsis	Controlling operation of the encoder.
Header	r_a_as_rzt2_if.h
Declaration	int32_t R_A_AS_Control(const int32_t id, const r_a_as_cmd_t cmd, void *const p_buf);
Description	This function controls operations of the encoder by using the cmd argument. See "4.4.4(1) Control Commands" for the operation of the control commands.
Argument	id : Designates the ID code to be used. (It is defined in r_a_as_rzt2_dat.h.) R_A_AS0_ID : Specifies channel 0. R_A_AS1_ID : Specifies channel 1. : : R_A_AS15_ID : Specifies channel 15. Others : Setting is not allowed.
	cmd : Command For the list of the commands, see Table 4.9, Control Commands of the R_A_AS_Control Function.
	p_buf : Arguments corresponding to each cmd.
Return value	R_A_AS_SUCCESS: Normal termination R_A_AS_ERR_INVALID_ARG: Abnormal termination (the id or cmd is not available or not specified.) See "4.4.4(1) Control Commands" for other returned values.
Note	Be sure to call R_A_AS_Open before calling this function. The channel 8, the channel 12, and the channel 15 are not available in this sample program. Calling this API function from within a callback function is not allowed.

(1) Control Commands**(a) R_A_AS_CMD_SET_PARAM**

R_A_AS_CMD_SET_PARAM	
Synopsis	Sets request information
Header	r_a_as_rzt2_if.h
Declaration	int32_t R_A_AS_Control(const int32_t id, const r_a_as_cmd_t cmd, void *const p_buf);
Description	This function sets request information
Argument	id : Designates the ID code to be used. (It is defined in r_a_as_rzt2_dat.h.) R_A_AS0_ID : Specifies channel 0. R_A_AS1_ID : Specifies channel 1. : : R_A_AS15_ID : Specifies channel 15. Others : Setting is not allowed.
	cmd : Designates R_A_AS_CMD_SET_PARAM.
	p_buf : Request information Designate the pointer to the structure r_a_as_req_t where the request information is stored. See section "4.10.1(2) r_a_as_req_t" for details.
Return value	R_A_AS_SUCCESS: Normal termination R_A_AS_ERR_INVALID_ARG: Abnormal termination (the id is not available or not specified, p_buf is null, or the p_buf member variable of the structure r_a_as_req_t is not a stipulated value.) R_A_AS_ERR_ACCESS: Abnormal termination (the applicable channel has not been started.)
Note	This control command is utilized only for setting request information. Transmission of commands to the encoder proceeds by using the following control commands. <ul style="list-style-type: none"> • R_A_AS_CMD_TX_TRG • R_A_AS_CMD_TX_ELC The channel 8, the channel 12, and the channel 15 are not available in this sample program. Calling this control command from within a callback function is not allowed.

(b) R_A_AS_CMD_ELC_DISABLE

R_A_AS_CMD_ELC_DISABLE	
Synopsis	Disables input of the ELC event triggers
Header	r_a_as_rzt2_if.h
Declaration	int32_t R_A_AS_Control(const int32_t id, const r_a_as_cmd_t cmd, void *const p_buf);
Description	This function disables event input triggers from the ELC.
Arguments	id : Designates the ID code to be used. (It is defined in r_a_as_rzt2_dat.h.) R_A_AS0_ID : Specifies channel 0. R_A_AS1_ID : Specifies channel 1. : : R_A_AS15_ID : Specifies channel 15. Others : Setting is not allowed.
	cmd : Designates R_A_AS_CMD_ELC_DISABLE.
	p_buf : Not used. (Designate NULL.)
Return value	R_A_AS_SUCCESS: Input of the ELC event trigger is disabled. R_A_AS_ERR_INVALID_ARG: Abnormal termination (the id is not available or not specified) R_A_AS_ERR_ACCESS: Abnormal termination (operation in response to input of the ELC event trigger is not in progress or the applicable channel has not been started.)
Note	The channel 8, the channel 12, and the channel 15 are not available in this sample program. Calling this control command from within a callback function is not allowed.

(c) R_A_AS_CMD_TX_TRG

R_A_AS_CMD_TX_TRG	
Synopsis	Starts transmission of requests to the encoder
Header	r_a_as_rzt2_if.h
Declaration	int32_t R_A_AS_Control(const int32_t id, const r_a_as_cmd_t cmd, void *const p_buf);
Description	This function starts transmission of requests to the encoder. In normal reception, a callback function which corresponds to the interrupt source being enabled is called every time a transmission of request is made. See section "4.5.1 a_as_txerr_callback" to "4.5.3 a_as_rxend_callback"
Arguments	id : Designates the ID code to be used. (It is defined in r_a_as_rzt2_dat.h.) R_A_AS0_ID : Specifies channel 0. R_A_AS1_ID : Specifies channel 1. : : R_A_AS15_ID : Specifies channel 15. Others : Setting is not allowed. cmd : Designates R_A_AS_CMD_TX_TRG. p_buf : Not used. (Designate NULL.)
Return value	R_A_AS_SUCCESS: Normal termination. R_A_AS_ERR_INVALID_ARG: Abnormal termination (the id is not available or not specified) R_A_AS_ERR_BUSY: Abnormal termination (during the process of transmission) R_A_AS_ERR_ACCESS: Abnormal termination (the applicable channel has not been started)
Note	This control command is utilized only for starting transmission of requests to the encoder. Use this command after setting request information by using control command R_A_AS_CMD_SET_PARAM. The channel 8, the channel 12, and the channel 15 are not available in this sample program. Calling this control command from within a callback function is not allowed.

(d) R_A_AS_CMD_TX_ELC**R_A_AS_CMD_TX_ELC**

Synopsis	Starts transmission of requests to the encoders in response to the input of an ELC event trigger.
Header	r_a_as_rzt2_if.h
Declaration	int32_t R_A_AS_Control(const int32_t id, const r_a_as_cmd_t cmd, void *const p_buf);
Description	<p>This function enables input of the ELC event trigger, and starts the transmission of requests to the encoder.</p> <p>In normal reception, a callback function which corresponds to the interrupt source being enabled is called every time a transmission of request is made. See section “4.5.1 a_as_txerr_callback” to “4.5.3 a_as_rxend_callback”</p> <p>An error code R_A_AS_ERR_BUSY is returned if this control command is executed while the ELC event trigger is in progress.</p>
Argument	<p>id : Designates the ID code to be used. (It is defined in r_a_as_rzt2_dat.h.)</p> <p style="padding-left: 20px;">R_A_AS0_ID : Specifies channel 0.</p> <p style="padding-left: 20px;">R_A_AS1_ID : Specifies channel 1.</p> <p style="padding-left: 20px;">:</p> <p style="padding-left: 20px;">R_A_AS15_ID : Specifies channel 15.</p> <p style="padding-left: 20px;">Others : Setting is not allowed.</p> <p>cmd : Designates R_A_AS_CMD_TX_ELC.</p> <p>p_buf : Not used. (Designate NULL.)</p>
Return value	<p>R_A_AS_SUCCESS: Normal termination</p> <p>R_A_AS_ERR_INVALID_ARG: Abnormal termination (the id is not available or not specified)</p> <p>R_A_AS_ERR_BUSY: Abnormal termination (transmission or the ELC event trigger operation is in progress)</p> <p>R_A_AS_ERR_ACCESS: Abnormal termination (the applicable channel has not been started.)</p>
Note	<p>This control command is utilized only for starting transmission of requests to the encoder. Use this command after setting request information by using control command R_A_AS_CMD_SET_PARAM.</p> <p>The channel 8, the channel 12, and the channel 15 are not available in this sample program.</p> <p>Calling this control command from within a callback function is not allowed.</p>

4.5 Specification of User-Defined Functions

4.5.1 a_as_txerr_callback

a_as_txerr_callback	
Synopsis	Callback function that conveys the result of transmission and reception when a timeout error is generated in normal reception.
Header	-
Declaration	void a_as_txerr_callback (r_a_as_result_t * p_result);
Description	<p>This is a callback function to be registered by the function R_A_AS_Control (R_A_AS_CMD_SET_PARAM). This function conveys the result of transmission and reception in normal reception. This function is called when an interrupt request is generated in response to a timeout error (PERI_ERR0). After this function is processed, the function a_as_rxend_callback() is called, too.</p> <p>Note that this function is in the context of the interrupt handler. To secure responsiveness to interrupts, be sure to return from this function quickly. The given function name is an example, and the user can freely select the name.</p>
Argument	<p>p_result : Result of transmission and reception</p> <p>This is the pointer to the array where the result of transmission and reception declared by the structure r_a_as_result_t is stored.</p> <p>See “Table 4.2, Result of Transmission and Reception Stored in Each Array Element” for each element. The result of transmission and reception for the encoder address, specified by the function R_A_AS_Control (R_A_AS_CMD_SET_PARAM), is updated.</p> <p>See “Table 4.3, Results of Transmission and Reception” for details on the result of transmission and reception.</p>
Return value	None
Note	<p>If the ELC event trigger is enabled, the result of transmission and reception should be acquired within the set timer interval.</p> <p>Depending on the timing of response from the encoder, this callback function may be called even if the function R_A_AS_Close, or R_A_AS_Control (R_A_AS_CMD_ELC_DISABLE) have been executed.</p>

4.5.2 a_as_rxset_callback

a_as_rxset_callback	
Synopsis	Callback function that conveys the result of transmission and reception when the setting of received data is complete in normal reception.
Header	-
Declaration	<code>void a_as_rxset_callback(r_a_as_result_t * p_result);</code>
Description	<p>This is a callback function to be registered by the function <code>R_A_AS_Control</code> (<code>R_A_AS_CMD_SET_PARAM</code>). This function conveys the result of transmission and reception in normal reception. This function is called when an interrupt request is generated in response to completion of the data reception (<code>AFMTi_EOF</code>). After this function is processed, the function <code>a_as_rxend_callback()</code> is called, too.</p> <p>Note that this function is in the context of the interrupt handler. To secure responsiveness to interrupts, be sure to return from this function quickly. The given function name is an example, and the user can freely select the name.</p>
Argument	<p><code>p_result</code> : Result of transmission and reception</p> <p>This is the pointer to the array where the result of transmission and reception declared by the structure <code>r_a_as_result_t</code> is stored.</p> <p>See “Table 4.2 Result of Transmission and Reception Stored in Each Array Element” for the contents of each element. The result of transmission and reception for the encoder address specified by the function <code>R_A_AS_Control(R_A_AS_CMD_SET_PARAM)</code> is updated.</p> <p>See “Table 4.3 Results of Transmission and Reception” for details on the result of transmission and reception.</p>
Return value	None
Note	<p>If the ELC event trigger is enabled, the result of transmission and reception should be acquired within the set timer interval.</p> <p>Depending on the timing of response from the encoder, this callback may be called even if the function <code>R_A_AS_Close</code>, or <code>R_A_AS_Control</code> (<code>R_A_AS_CMD_ELC_DISABLE</code>) have been executed.</p>

4.5.3 a_as_rxend_callback

a_as_rxend_callback	
Synopsis	Callback function that conveys the result of transmission and reception when the reception of data has been completed in normal reception.
Header	-
Declaration	void a_as_rxend_callback (r_a_as_result_t * p_result);
Description	<p>This is a callback function to be registered by the function R_A_AS_Control (R_A_AS_CMD_SET_PARAM). This function conveys the result of transmission and reception in normal reception. When a timeout error interrupt (PERI_ERR0) or a completion of the data reception interrupt (AFMTi_EOF) is generated, this function is called following the function a_as_txerr_callback() or the function a_as_rxset_callback() call.</p> <p>Note that this function is in the context of the interrupt handler. To secure responsiveness to interrupts, be sure to return from this function quickly. The given function name is an example, and the user can freely select the name.</p>
Argument	<p>p_result : Result of transmission and reception</p> <p>This is the pointer to the array where the result of transmission and reception declared by the structure r_a_as_result_t is stored.</p> <p>See "Table 4.2 Result of Transmission and Reception Stored in Each Array Element" for the contents of each element. The result of transmission and reception for the encoder address specified by the function R_A_AS_Control(R_A_AS_CMD_SET_PARAM) is updated.</p> <p>See "Table 4.3 Results of Transmission and Reception" for details on the result of transmission and reception.</p>
Return value	None
Note	<p>If the ELC event trigger is enabled, the result of transmission and reception should be acquired within the set timer interval.</p> <p>Depending on the timing of response from the encoder, this callback may be called even if the function R_A_AS_Close or R_A_AS_Control (R_A_AS_CMD_ELC_DISABLE) have been executed.</p>

4.5.4 a_as_elctimer_callback

a_as_elctimer_callback

Synopsis	Callback function that conveys the result of transmission and reception when the data reception is complete in continuous operation of the ELC event trigger.
Header	-
Declaration	<code>void a_as_elctimer_callback(r_a_as_result_t * p_result);</code>
Description	This is a callback function to be registered by the function <code>R_A_AS_Control</code> (<code>R_A_AS_CMD_SET_PARAM</code>). This function conveys the result of transmission and reception in normal reception. This function is called every time when an interrupt request is generated in response to completion of the data reception (<code>AFMTi_EOF</code>). Note that this function is in the context of the interrupt handler. To secure responsiveness to interrupts, be sure to return from this function quickly. The given function name is an example, and the user can freely select the name.
Argument	<p><code>p_result</code> : Result of transmission and reception</p> <p>This is the pointer to the array where the result of transmission and reception declared by the structure <code>r_a_as_result_t</code> is stored.</p> <p>See “Table 4.2 Result of Transmission and Reception Stored in Each Array Element” for the contents of each element. The result of transmission and reception for the encoder address specified by the function <code>R_A_AS_Control(R_A_AS_CMD_SET_PARAM)</code> is updated.</p> <p>See “Table 4.3 Results of Transmission and Reception” for details on the result of transmission and reception.</p>
Return value	None
Note	<p>If the ELC event trigger is enabled, the result of transmission and reception should be acquired within the set timer interval.</p> <p>Depending on the timing of response from the encoder, this callback may be called even if the function <code>R_A_AS_Close</code> or <code>R_A_AS_Control</code> (<code>R_A_AS_CMD_ELC_DISABLE</code>) have been executed.</p>

Table 4.2 Result of Transmission and Reception Stored in Each Array Element

Array Number	Content
p_result[0]	Result of transmission and reception for the encoder section ENC1.
p_result[1]	Result of transmission and reception for the encoder section ENC2.
p_result[2]	Result of transmission and reception for the encoder section ENC3.
p_result[3]	Result of transmission and reception for the encoder section ENC4.
p_result[4]	Result of transmission and reception for the encoder section ENC5.
p_result[5]	Result of transmission and reception for the encoder section ENC6.
p_result[6]	Result of transmission and reception for the encoder section ENC7.
p_result[7]	Result of transmission and reception for the encoder section ENC8.

Table 4.3 Results of Transmission and Reception

Interrupt Source	Results of Transmission and Reception (Member variables of p_result)		
	Result	Data	Status
Timeout error (PERI_ERR0)	Only valid when used in the callback functions	Invalid	Only valid when used in the callback functions.
Completion of the data reception (AFMTi_EOF) *1	Only valid when used in the callback functions.	Valid *2	Only valid when used in the callback functions.

Note: 1. i = 00 to 15

2. If the ELC event trigger is disabled, the data reception results are valid until next request.
If the ELC event trigger is enabled, the data reception results are valid until next AFMTi_EOF interrupt is generated.

4.6 Interrupt Handlers

4.6.1 a_as0_int_isr

a_as0_int_isr	
Synopsis	Interrupt handler for AFMT0_EOF
Header	-
Declaration	static void a_as0_int_isr(void);
Description	This is the interrupt handler for the completion of A_AS channel 0 data reception.
Argument	None
Return value	None

4.6.2 a_as1_int_isr

a_as1_int_isr	
Synopsis	Interrupt handler for AFMT1_EOF
Header	-
Declaration	static void a_as1_int_isr(void);
Description	This is the interrupt handler for the completion of A_AS channel 1 data reception.
Argument	None
Return value	None

4.6.3 a_as2_int_isr

a_as2_int_isr	
Synopsis	Interrupt handler for AFMT2_EOF
Header	-
Declaration	static void a_as2_int_isr(void);
Description	This is the interrupt handler for the completion of A_AS channel 2 data reception.
Argument	None
Return value	None

4.6.4 a_as3_int_isr

a_as3_int_isr	
Synopsis	Interrupt handler for AFMT3_EOF
Header	-
Declaration	static void a_as3_int_isr(void);
Description	This is the interrupt handler for the completion of A_AS channel 3 data reception.
Argument	None
Return value	None

4.6.5 a_as4_int_isr

a_as4_int_isr	
Synopsis	Interrupt handler for AFMT4_EOF
Header	-
Declaration	static void a_as4_int_isr(void);
Description	This is the interrupt handler for the completion of A_AS channel 4 data reception.
Argument	None
Return value	None

4.6.6 a_as5_int_isr**a_as5_int_isr**

Synopsis	Interrupt handler for AFMT5_EOF
Header	-
Declaration	static void a_as5_int_isr(void);
Description	This is the interrupt handler for the completion of A_AS channel 5 data reception.
Argument	None
Return value	None

4.6.7 a_as6_int_isr**a_as6_int_isr**

Synopsis	Interrupt handler for AFMT6_EOF
Header	-
Declaration	static void a_as6_int_isr(void);
Description	This is the interrupt handler for the completion of A_AS channel 6 data reception.
Argument	None
Return value	None

4.6.8 a_as7_int_isr**a_as7_int_isr**

Synopsis	Interrupt handler for AFMT7_EOF
Header	-
Declaration	static void a_as7_int_isr(void);
Description	This is the interrupt handler for the completion of A_AS channel 7 data reception.
Argument	None
Return value	None

4.6.9 a_as9_int_isr**a_as9_int_isr**

Synopsis	Interrupt handler for AFMT9_EOF
Header	-
Declaration	static void a_as9_int_isr(void);
Description	This is the interrupt handler for the completion of A_AS channel 9 data reception.
Argument	None
Return value	None

4.6.10 a_as10_int_isr**a_as10_int_isr**

Synopsis	Interrupt handler for AFMT10_EOF
Header	-
Declaration	static void a_as10_int_isr(void);
Description	This is the interrupt handler for the completion of A_AS channel 10 data reception.
Argument	None
Return value	None

4.6.11 a_as11_int_isr

a_as11_int_isr

Synopsis	Interrupt handler for AFMT11_EOF
Header	-
Declaration	static void a_as11_int_isr(void);
Description	This is the interrupt handler for the completion of A_AS channel 11 data reception.
Argument	None
Return value	None

4.6.12 a_as13_int_isr

a_as13_int_isr

Synopsis	Interrupt handler for AFMT13_EOF
Header	-
Declaration	static void a_as13_int_isr(void);
Description	This is the interrupt handler for the completion of A_AS channel 13 data reception.
Argument	None
Return value	None

4.6.13 a_as14_int_isr

a_as14_int_isr

Synopsis	Interrupt handler for AFMT14_EOF
Header	-
Declaration	static void a_as14_int_isr(void);
Description	This is the interrupt handler for the completion of A_AS channel 14 data reception.
Argument	None
Return value	None

4.6.14 a_as_err_isr

a_as_err_isr

Synopsis	Interrupt handler for PERI_ERR0
Header	-
Declaration	static void a_as_err_isr(void);
Description	This is the interrupt handler for the timeout of A_AS channel 0 to 15.
Argument	None
Return value	None

4.7 Interrupt

Interrupt requests used with the A-format driver are listed below.

Table 4.4 Interrupt for the A-format Driver

Interrupt Request	ID *1		Description
	CR52 ver.	CA55 ver.	
ENCIF_ERR0	388	417	Generated in response to the timeout of channel 0 to 15.
AFMT0_EOF	389	716	Generated in response to the completion of channel 0 reception.
AFMT1_EOF	390	720	Generated in response to the completion of channel 1 reception.
AFMT2_EOF	391	724	Generated in response to the completion of channel 2 reception.
AFMT3_EOF	392	728	Generated in response to the completion of channel 3 reception.
AFMT4_EOF	393	732	Generated in response to the completion of channel 4 reception.
AFMT5_EOF	394	736	Generated in response to the completion of channel 5 reception.
AFMT6_EOF	395	740	Generated in response to the completion of channel 6 reception.
AFMT7_EOF	396	744	Generated in response to the completion of channel 7 reception.
AFMT8_EOF	-	-	This interrupt request is not used. *2
AFMT9_EOF	397	752	Generated in response to the completion of channel 9 reception.
AFMT10_EOF	398	756	Generated in response to the completion of channel 10 reception.
AFMT11_EOF	399	760	Generated in response to the completion of channel 11 reception.
AFMT12_EOF	-	-	This interrupt request is not used. *2
AFMT13_EOF	400	768	Generated in response to the completion of channel 13 reception.
AFMT14_EOF	401	772	Generated in response to the completion of channel 14 reception.
AFMT15_EOF	-	-	This interrupt request is not used. *2

- Note: 1. This sample program has a CR52 version that runs on the CPU core Cortex-R52 and a CA55 version that runs on the CPU core Cortex-A55. CR52 ver. and CA55 ver. are descriptions of the respective version.
2. The channel 8, the channel 12, and the channel 15 are not available in this sample program. The interrupt requests AFMT8_EOF, AFMT12_EOF and AFMT15_EOF are not generated.

4.8 Constants/Error Codes

See the individual tables below for settings and descriptions related to the constants and error codes.

Table 4.5 List of Tables for Definitions of Constants and Error Codes

Table number	Contents
Table 4.6	User-defined Constants to be Used in the A-format Driver (r_a_as_rzt2_config.h)
Table 4.7	Driver Type
Table 4.8	Methods of Connection between A_AS and Encoders
Table 4.9	Control Commands of the R_A_AS_Control Function
Table 4.10	Bitrate
Table 4.11	Encoder Addresses
Table 4.12	Commands
Table 4.13	Error Codes

Table 4.6 User-defined Constants to be Used in the A-format Driver (r_a_as_rzt2_config.h)

Constant Name	Setting	Description
R_AFMT_T2_ONE_2500KBPS	0x0000	The value set in the BRSEL register TM bit when the connection is one-to-one, and the bit rate is 2.5 Mbps. *
R_AFMT_T2_ONE_4MBPS	0x0000	The value set in the BRSEL register TM bit when the connection is one-to-one, and the bit rate is 4 Mbps. *
R_AFMT_T2_ONE_6670KBPS	0x0000	The value set in the BRSEL register TM bit when the connection is one-to-one, and the bit rate is 6.67 Mbps. *
R_AFMT_T2_ONE_8MBPS	0x0000	The value set in the BRSEL register TM bit when the connection is one-to-one, and the bit rate is 8 Mbps. *
R_AFMT_T2_BUS_2500KBPS	0x001A	The value set in the BRSEL register TM bit when the connection is a bus connection, and the bit rate is 2.5 Mbps. *
R_AFMT_T2_BUS_4MBPS	0x0010	The value set in the BRSEL register TM bit when the connection is a bus connection, and the bit rate is 4 Mbps. *
R_AFMT_T2_BUS_6670KBPS	0x0009	The value set in the BRSEL register TM bit when the connection is a bus connection, and the bit rate is 6.67 Mbps. *
R_AFMT_T2_BUS_8MBPS	0x0008	The value set in the BRSEL register TM bit when the connection is a bus connection, and the bit rate is 8 Mbps. *

Note: In this sample program, the values set in each register are the recommended values.

Table 4.7 Driver Type

Constant Name	Setting	Description
R_A_AS_A_FORMAT	0	Designates the A-format driver.

Table 4.8 Methods of Connection between A_AS and Encoders

Constant Name	Setting	Description
R_A_AS_ONE_FOR_ONE	0	One-to-one connection
R_A_AS_BUS	1	Bus connection

Table 4.9 Control Commands of the R_A_AS_Control Function

Constant Name	Setting	Description
R_A_AS_CMD_SET_PARAM	0xAF000000	Sets requests information
R_A_AS_CMD_ELC_DISABLE	0xAF000002	Disable input of the ELC event trigger.
R_A_AS_CMD_TX_TRG	0xAF000003	Starts transmission of a command.
R_A_AS_CMD_TX_ELC	0xAF000005	Starts transmission of a command by input of the ELC event trigger.

Table 4.10 Bitrate

Constant Name	Setting	Description
R_A_AS_2500KBPS	0	2.5 Mbps
R_A_AS_4MBPS	1	4 Mbps
R_A_AS_6670KBPS	2	6.67 Mbps
R_A_AS_8MBPS	3	8 Mbps

Table 4.11 Encoder Addresses

Constant Name	Setting	Description
R_A_AS_ECN1	0	The address of the encoder section ENC1.
R_A_AS_ECN2	1	The address of the encoder section ENC2.
R_A_AS_ECN3	2	The address of the encoder section ENC3.
R_A_AS_ECN4	3	The address of the encoder section ENC4.
R_A_AS_ECN5	4	The address of the encoder section ENC5.
R_A_AS_ECN6	5	The address of the encoder section ENC6.
R_A_AS_ECN7	6	The address of the encoder section ENC7.
R_A_AS_ECN8	7	The address of the encoder section ENC8.

Table 4.12 Commands

Constant Name	Setting	Description
R_A_AS_CDF0	0	The value defined for the command data frame CDF0.
R_A_AS_CDF1	1	The value defined for the command data frame CDF1.
R_A_AS_CDF2	2	The value defined for the command data frame CDF2.
R_A_AS_CDF3	3	The value defined for the command data frame CDF3.
R_A_AS_CDF4	4	The value defined for the command data frame CDF4.
R_A_AS_CDF5	5	The value defined for the command data frame CDF5.
R_A_AS_CDF6	6	The value defined for the command data frame CDF6.
R_A_AS_CDF7	7	The value defined for the command data frame CDF7.
R_A_AS_CDF8	8	The value defined for the command data frame CDF8.
R_A_AS_CDF9	9	The value defined for the command data frame CDF9.
R_A_AS_CDF10	10	The value defined for the command data frame CDF10.
R_A_AS_CDF11	11	The value defined for the command data frame CDF11.
R_A_AS_CDF12	12	The value defined for the command data frame CDF12.
R_A_AS_CDF13	13	The value defined for the command data frame CDF13.
R_A_AS_CDF14	14	The value defined for the command data frame CDF14.
R_A_AS_CDF15	15	The value defined for the command data frame CDF15.
R_A_AS_CDF16	16	The value defined for the command data frame CDF16.
R_A_AS_CDF17	17	The value defined for the command data frame CDF17.
R_A_AS_CDF18	18	The value defined for the command data frame CDF18.
R_A_AS_CDF19	19	The value defined for the command data frame CDF19.
R_A_AS_CDF21	21	The value defined for the command data frame CDF21.
R_A_AS_CDF22	22	The value defined for the command data frame CDF22.
R_A_AS_CDF27	27	The value defined for the command data frame CDF27.
R_A_AS_CDF28	28	The value defined for the command data frame CDF28.
R_A_AS_CDF29	29	The value defined for the command data frame CDF29.
R_A_AS_CDF30	30	The value defined for the command data frame CDF30.

Table 4.13 Error Codes

Constant Name	Setting	Description
R_A_AS_SUCCESS	0	Normal termination
R_A_AS_ERR_INVALID_ARG	-1	Argument error
R_A_AS_ERR_BUSY	-2	The API cannot be executed.
R_A_AS_ERR_ACCESS	-3	API execution order error.

4.9 Fixed-Width Integer

Table below lists the fixed-width integers used in the sample code. These fixed-width integers are defined in the standard libraries.

Table 4.14 Fixed-Width Integers for the Sample Code

Symbol	Description
int8_t	8-bit signed integer
int16_t	16-bit signed integer
int32_t	32-bit signed integer
int64_t	64-bit signed integer
uint8_t	8-bit unsigned integer
uint16_t	16-bit unsigned integer
uint32_t	32-bit unsigned integer
uint64_t	64-bit unsigned integer

4.10 Structure/Unions/Enumerated Types

The major structures, unions, and enumerated types are listed below.

4.10.1 Structures

(1) r_a_as_info_t

Initialization information of the A_AS control unit,

```
typedef struct
{
    uint8_t    connect;    Connection method
                    Designate the method of connection between A_AS and the
                    encoders. See "Table 4.8, Methods of Connection between A_AS
                    and Encoders" for the values to be designated.
                    Note: This setting is reflected in the BRSEL register.

    uint8_t    bitrate;    Bit rate
                    Designate the bit rate for communications with the encoder. See
                    "Table 4.10, Bitrate" for the values to be designated.
                    Note: This setting is reflected in the BRSEL register.

    uint16_t   ifmg;       Margin value
                    Note: This is reserved for driver interface compatibility with RZ/T2M
                    group A-format driver. This setting value is not used for RZ/N2H.
} r_a_as_info_t
```

(2) r_a_as_req_t

Information of requests to be sent to the encoders.

```
typedef struct
{
    uint8_t      encadr;      Encoder address
                        Designate the encoder address. See "Table 4.11 Encoder
                        Addresses" for the value to be designated.
                        This setting is reflected in the XEA bit of the COMMAND
                        register.

    uint8_t      cmd;        Command
                        Designate the command code to be sent to the encoder. See
                        "Table 4.12 Commands" for the value to be designated.
                        If the value is not listed in the said table and exceeds 0x20, an
                        error with the error code R_A_AS_ERR_INVALID_ARG is
                        generated.
                        Some commands are not available depending on the
                        connection method.

    uint8_t      memadr;     Memory address
                        Designate the address of the memory in the encoder. *1
                        Set this value only in the following cases:
                        cmd = R_A_AS_CDF13
                        cmd = R_A_AS_CDF14

    uint16_t     memdat;     Data to be written to the memory
                        Designate the data to be written to the memory.
                        Set this value only in the following case:
                        cmd = R_A_AS_CDF14

    uint32_t     encid;      Recognition code
                        Designate the 24-bit recognition code.
                        Set this value only in the following cases:
                        cmd = R_A_AS_CDF18
                        cmd = R_A_AS_CDF19

    r_a_as_result_cb_t cbadr_txerr; The pointer to the callback function *2 to be called in response
                        to PERI_ERR0 interrupt request. See "4.5.1,
                        a_as_txerr_callback" for details.

    r_a_as_result_cb_t cbadr_rxset; The pointer to the callback function *2 to be called in response
                        to AFMTi_EOF (i = 00 to 15) interrupt request. See "4.5.2,
                        a_as_rxset_callback" for details.

    r_a_as_result_cb_t cbadr_rxend; The pointer to the callback function *2 to be called following the
                        cbadr_txerr() function or cbadr_rxset() function in response to
                        PERI_ERR0 interrupt or AFMTi_EOF (i = 00 to 15) interrupt
                        request. See "4.5.3, a_as_rxend_callback" for details.

    bool         pre;        Set true in this variable to set request information while
                        transmission and reception of data by the ELC event trigger is
                        in progress. Set false to set request information in other cases.
                        (true: Set request information while transmission and reception
                        of data by the ELC event trigger is in progress)
} r_a_as_req_t
```

- Note: 1. For the command R_A_AS_CDF13, the accessible address range is between 0x00 and 0xFF. For the command R_A_AS_CDF14, the accessible address range is between 0x00 and 0xEF.
 2. Callback function will not be run if the pointer is NULL.

(3) r_a_as_result_t

Result of transmission and reception in normal reception

```
typedef struct
{
    r_a_as_req_err_t  result;    Result of transmission and reception
                                See the enumerated type r_a_as_req_err_t for details.
    r_a_as_data_t    data;      Reception data
                                See the structure type r_a_as_data_t for details.
    r_a_as_status_t  status;    State of the A_AS
                                See the structure type r_a_as_status_t for details.
} r_a_as_result_t
```

(4) r_a_as_data_t

Data received in normal reception

```
typedef struct
{
    uint32_t         rxi;       ENCnRXDATA0 register value
                                The value of the ENCnRXDATA0 register is stored here.
    uint32_t         rxd0;     ENCnRXDATA1 register value
                                The value of the ENCnRXDATA1 register is stored here.
    uint32_t         rxd1;     ENCnRXDATA2 register value
                                The value of the ENCnRXDATA2 register is stored here.
} r_a_as_data_t
```

(5) r_a_as_status_t

State of the A_AS on transmission or reception

```
typedef struct
{
    bool    iwdgerr;    IF watchdog errors. Corresponds to timeout errors.
    bool    dwdgerr;    DF watchdog errors. Corresponds to timeout errors.
    bool    starterr;   Start bit errors. Corresponds to CA[1] FORM status flag.
    bool    stoperr;    Stop bit errors. Corresponds to CA[1] FORM status flag.
    bool    syncerr;    Sync code errors. Corresponds to CA[2] SYNC status flag.
    bool    rxeaerr;    Received encoder address error. Corresponds to CA[0] CMD status flag.
    bool    crcerr;     CRC error. Corresponds to CA[3] CRC status flag.
    bool    rxccerr;    Received command code error. Corresponds to CA[0] CMD status flag.
    bool    mdaterr;    Indicates EEPROM data error. *1
    bool    madrerr;    Indicates EEPROM address error. *1
    bool    rxdzerr;    Indicates ID code error. *1
    bool    fd1err;     Indicates fixed-data (1) error. *1
    bool    fd2err;     Indicates fixed-data (2) error. *1
    bool    fd3err;     Indicates fixed-data (3) error. *1
    bool    fd5err;     Indicates fixed-data (5) error. *1
    bool    elcin;      Information in response to ELCIN input is being stored. *1
    uint8_t txcc;      Transmission command code is stored.
                        (0: CDF0 to 19 and 23 to 30, 1: CDF21, 2: CDF22)
    bool    rxset;      This value indicates whether the setting of received data is complete.
                        (true: Ready to read; false: Not ready to read)
    bool    timer;      Indicates whether the timer is operating or not. *1
    bool    txerr;      Indicates transmission error. *1
    bool    rxend;      Indicates completion of reception. (true: received; false: not received)
} r_a_as_status_t
```

Note: 1. This is reserved for driver interface compatibility with RZ/T2M group A-format encoder driver. This is not used in the driver for RZ/N2H. It is always false.

4.10.2 Unions

Unions are not used in this sample program.

4.10.3 Enumerated Types

(1) r_a_as_req_err_t

Result of reception from the encoder

```
typedef enum
{
    R_A_AS_REQ_SUCCESS = 0,           Normal termination of data transmission and reception
    R_A_AS_REQ_ERR                   An error occurred in data transmission or reception.
                                     This error code is generated even if one of the error
                                     indicators (excluding timer, rxend, rxset, elcin, and txcc) of
                                     the structure r_a_as_status_t is "true".

    R_A_AS_REQ_BP_ERR                The reception FIFO buffer is full.
                                     This error code is generated only in bypass reception.
} r_a_as_req_err_t
```

4.11 Sample Program

4.11.1 Operation Overview

The sample program described in this application note supports bus connection of up to eight A-format-compliant encoders (Nikon MAR-M50A). This sample program handles the following processes.

- 1) Transmitting requests input through the terminal I/O for the debugger to the encoder, by writing to the TXTRG register.
- 2) Displaying the data received from the encoder in the console.
- 3) Transmitting commands and receiving results in response by using the ELC event trigger function of the AFMT module. The ELC links input events for the AFMT module to events output by the GPT. See "Figure 4.6 Flowchart of a_as_elctimer" for an example setting of input events.

(1) System Block Diagram

A system block diagram is shown below.

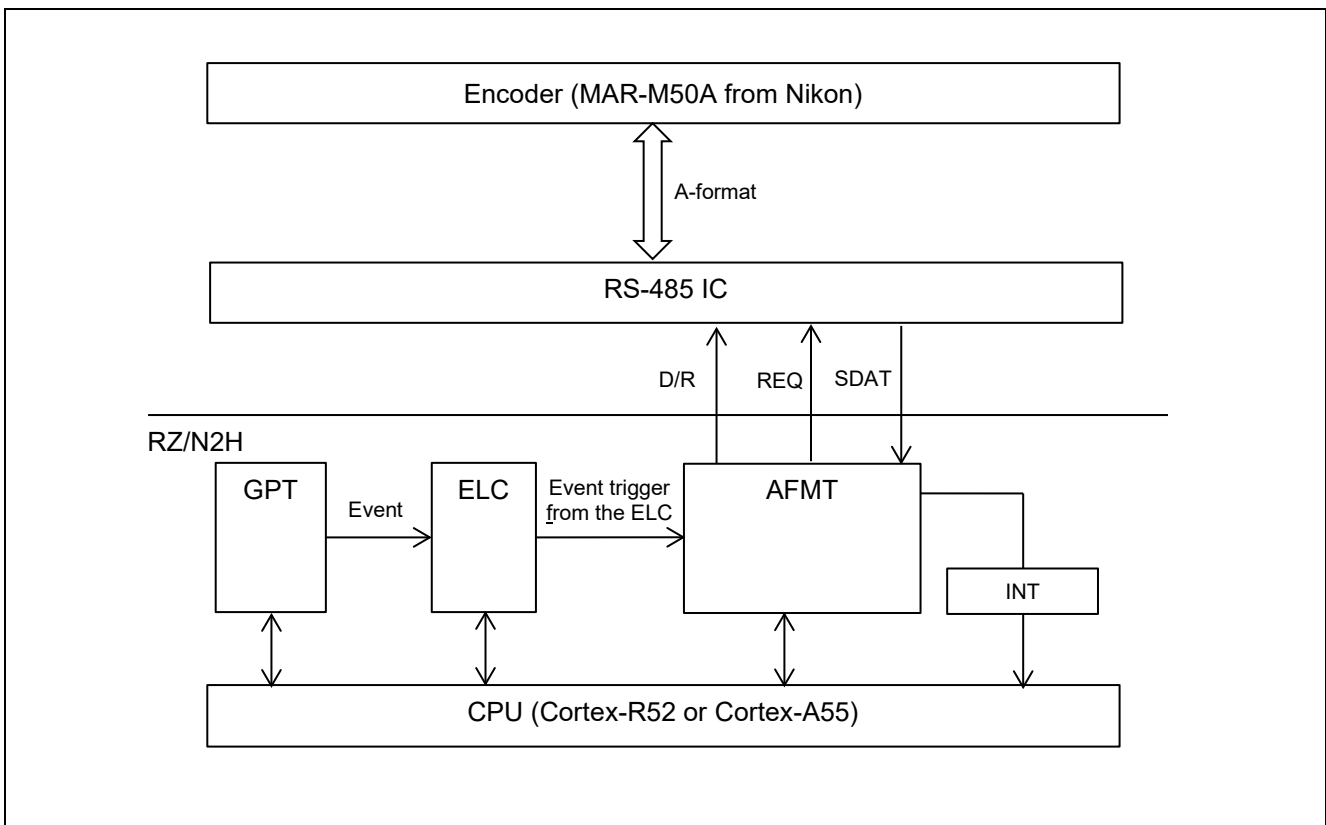

Figure 4.1 System Block Diagram

(2) Software Structure

Figure 4.2 shows a system block diagram.

The A-format driver has four sections: the opening process part configured of the function R_A_AS_Open, the closing process part configured of the function R_A_AS_Close, the request transmission part configured of the function R_A_AS_Control, and the data reception part (interrupt handler) configured of the callback functions.

The A-format driver controller section of the sample program controls the A-format driver and sends requests, and the results indication section indicates the result of data reception.

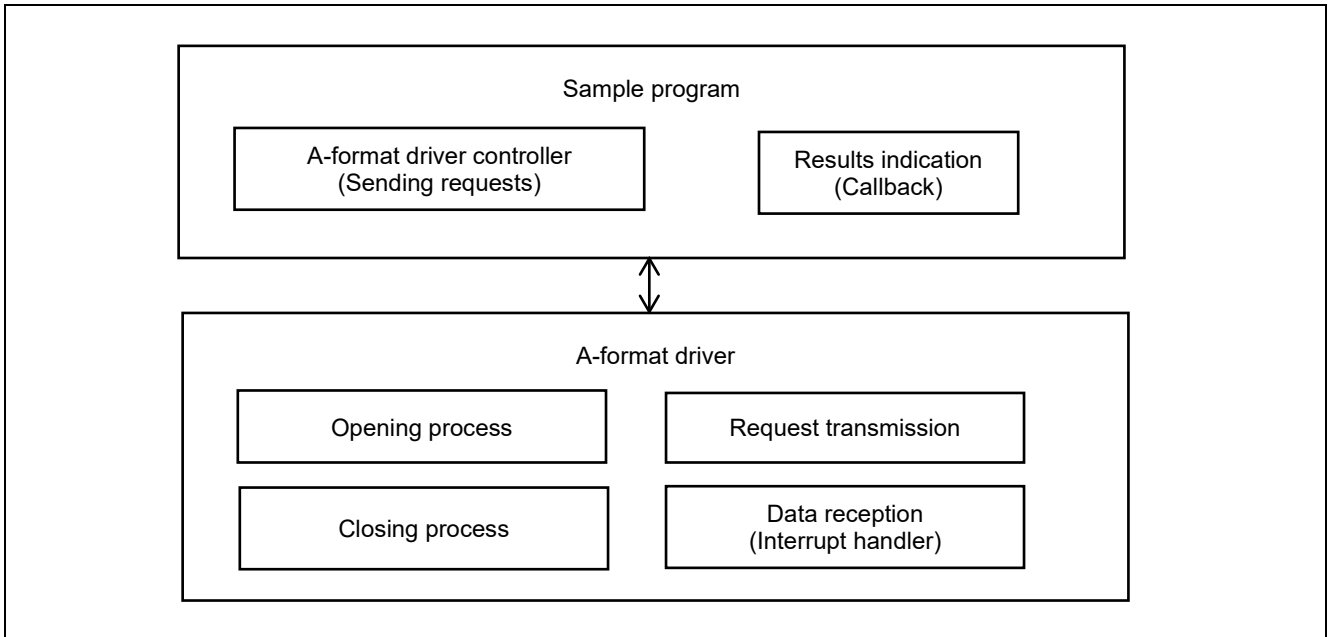

Figure 4.2 Software Structure

4.11.2 Functions Used in the Sample Program

The major functions used in the sample program are listed below.

Table 4.15 Major Functions Used in the Sample Program

Function Name	Page
hal_entry	34
enc_main	34
a_as_cmd_control	34
a_as_enc_init	35
a_as_req	35
a_as_elctimer	35
a_as_elcstop	36
a_as_exit	36
a_as_txerr_callback	36
a_as_rxset_callback	36
a_as_rxend_callback	37
a_as_elctimer_callback	37

4.11.3 Specifications of Sample Program Functions

(1) hal_entry

hal_entry	
Synopsis	Entry function of the A-format sample program
Header	-
Declaration	void hal_entry(void);
Description	This is the entry function of the A-format sample program. The function enc_main() is called from here.
Argument	None
Return value	None

(2) enc_main

enc_main	
Synopsis	Main function of the A-format sample program.
Header	-
Declaration	int32_t enc_main(uint8_t ch);
Description	This is the main function of the A-format sample program. See section 4.11.6(1), Flowchart of enc_main for details.
Argument	ch Encoder channel 0: specify channel 0, 1: specify channel 1, ..., 15: specify channel 15
Return value	0: Normal termination Others: Abnormal termination (an error code in the encoder interface)
Note	The channel 8, the channel 12, and the channel 15 are not available in this sample program.

(3) a_as_cmd_control

a_as_cmd_control	
Synopsis	Controls the A-format driver.
Header	-
Declaration	static void a_as_cmd_control(int32_t id);
Description	This function performs the following processes. Starting control of the encoder Input processing of the console command Ending control of the encoder
Argument	id Encoder ID R_A_AS0_ID: specify channel 0 encoder ID R_A_AS1_ID: specify channel 1 encoder ID : R_A_AS15_ID: specify channel 15 encoder ID
Return value	None
Note	The channel 8, the channel 12, and the channel 15 are not available in this sample program.

(4) a_as_enc_init

a_as_enc_init	
Synopsis	Initializing the encoder
Header	-
Declaration	static int32_t a_as_enc_init(int32_t id);
Description	This function is for initializing the encoder. The command data frame CDF8 is transmitted eight times consecutively to clear the status flag.
Argument	id Encoder ID R_A_AS0_ID: Specify channel 0 encoder ID R_A_AS1_ID: Specify channel 1 encoder ID : R_A_AS15_ID: Specify channel 15 encoder ID
Return value	0: Normal termination Others: Abnormal termination (an error code in the encoder interface)
Note	The channel 8, the channel 12, and the channel 15 are not available in this sample program.

(5) a_as_req

a_as_req	
Synopsis	Console command "req" function
Header	-
Declaration	static void a_as_req(uint32_t arg_num, char_t *p_arg[]);
Description	This function is executed when the console command "req" is input. See section "4.11.6(3), Flowchart of a_as_req" and section "4.11.8, Console Commands" for details.
Argument	arg_num The number of character strings input through the console *p_arg[] The starting address where the character strings are stored.
Return value	None

(6) a_as_elctimer

a_as_elctimer	
Synopsis	Console command "elctimer" function
Header	-
Declaration	static void a_as_elctimer(uint32_t arg_num, char_t *p_arg[]);
Description	This function is executed when the console command "elctimer" is input. See section "4.11.6(4), Flowchart of a_as_elctimer" and section "4.11.8, Console Commands" for details.
Arguments	arg_num The number of character strings input through the console. *p_arg[] The starting address where the character strings are stored.
Return value	None

(7) a_as_elcstop

a_as_elcstop	
Synopsis	Console command "elcstop" function
Header	-
Declaration	static void a_as_elcstop(uint32_t arg_num, char_t *p_arg[]);
Description	This function is executed when the console command "elcstop" is input. See section "4.11.6(5), Flowchart of a_as_elcstop" and section "4.11.8, Console Commands" for details.
Argument	arg_num The number of character strings input through the console *p_arg[] The starting address where the character strings are stored.
Return value	None

(8) a_as_exit

a_as_exit	
Synopsis	Console command "exit" function
Header	-
Declaration	static void a_as_exit(uint32_t arg_num, char_t *p_arg[]);
Description	This function is executed when the console command "exit"
Argument	arg_num The number of character strings input through the console *p_arg[] The starting address where the character strings are stored.
Return value	None

(9) a_as_txerr_callback

a_as_txerr_callback	
Synopsis	Callback for the console command "req" when a transmission error is generated
Header	-
Declaration	static void a_as_txerr_callback(r_a_as_result_t *p_result);
Description	This is a callback function that is executed when the console command "req" is input. It holds a pointer to the result of transmitted A-format request in normal reception in the variable a_as_result and indicates that a timeout error is generated. See section "4.11.6(6), Flowchart of a_as_txerr_callback" for details.
Argument	*p_result The address in the RAM where the result of transmission of the request and reception starts
Return value	None

(10) a_as_rxset_callback

a_as_rxset_callback	
Synopsis	Callback for the console command "req" when the setting of received data is complete.
Header	-
Declaration	static void a_as_rxset_callback(r_a_as_result_t *p_result);
Description	This is a callback function that is executed when the console command "req" is input. It holds a pointer to the result of the transmitted an A-format request and received data in response in normal reception in the variable a_as_result and indicates completion of the setting of received data. See section "4.11.6(7), Flowchart of a_as_rxset_callback" for details.
Argument	*p_result The address in the RAM where the result of transmission of the request and reception starts.
Return value	

(11) a_as_rxend_callback

a_as_rxend_callback	
Synopsis	Callback for the console command "req" when reception of the data has been completed.
Header	-
Declaration	static void a_as_rxend_callback(r_a_as_result_t *p_result);
Description	This is a callback function that is executed when the console command "req" is input. It indicates completion of the reception of data in response to the A-format request in normal reception. See section "4.11.6(8), Flowchart of a_as_rxend_callback" for details.
Argument	*p_result The address in the RAM where the result of transmission of the request and reception starts.
Return value	None

(12) a_as_elctimer_callback

a_as_elctimer_callback	
Synopsis	Callback for the console command "elctimer".
Header	-
Declaration	static void a_as_elctimer_callback(r_a_as_result_t * p_result);
Description	This is a callback function that is executed when the console command "elctimer" is input. It holds the result of the transmitted request and received data in the variables a_as_ti_result and a_as_ti_data. See section "4.11.6(9), Flowchart of a_as_elctimer_callback" for details.
Argument	*p_result The address in the RAM where the result of transmission of the request and reception starts.
Return value	None

4.11.4 Variables Used in the Sample Program

The major static variables used in the sample program are listed below.

Table 4.16 Static Variables Used in the Sample Program

Type	Variable Name	Description
bool	a_as_flg	Transmission and reception completion flag. (true: transmission and reception completed; false: transmission and reception in progress)
r_a_as_result_t	a_as_result[A_AS_ENC_NUM]	The results of acquisition are stored.
bool	a_as_elc_flg	ELC event input trigger flag (true: ELC event input trigger operation is in progress; false: ELC event input trigger operation is stopped)
bool	elc_trans_flg	The flag that indicates the state of transmission and reception of data from the ELC event input trigger. (true: Transmission and reception in progress, false: Transmission and reception completed)
r_a_as_req_t	a_as_req_elc	Holds the request information while ELC event input trigger operation is in progress.

4.11.5 Constants Used in the Sample Program

The major constants used in the sample program are listed below.

Table 4.17 Major Constants Used in the Sample Program

Constant	Setting	Description
A_AS_ENC_NUM	8	The number of connected encoders.

4.11.6 Flowchart of Main Process

The flowcharts for the major processes are given below.

(1) Flowchart of enc_main

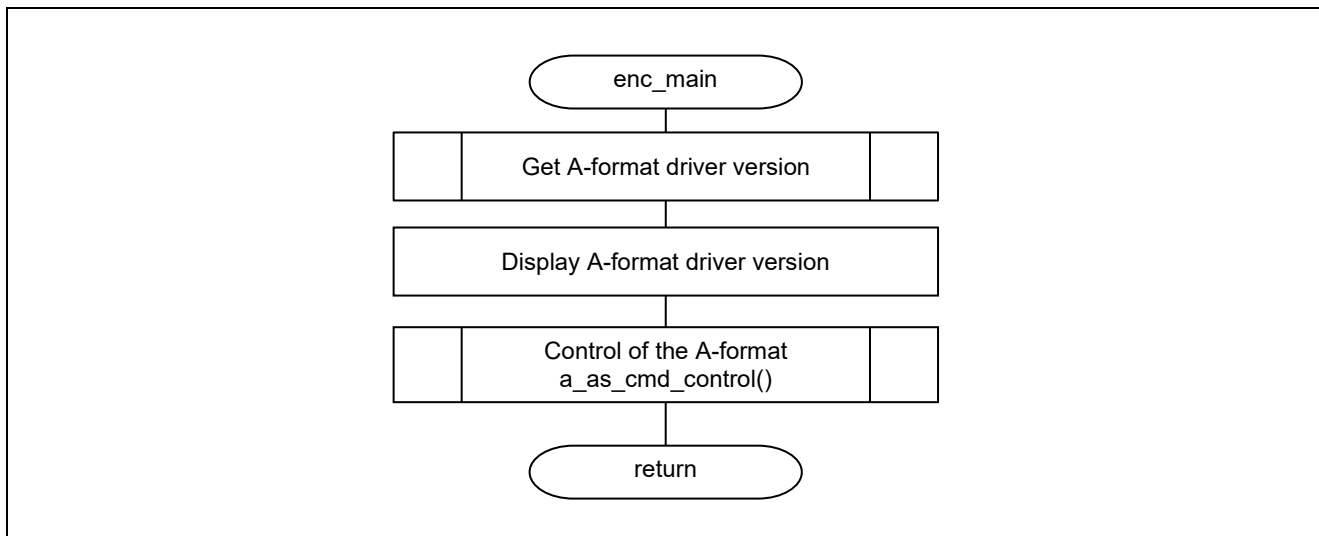

Figure 4.3 Flowchart of enc_main

(2) Flowchart of a_as_cmd_control

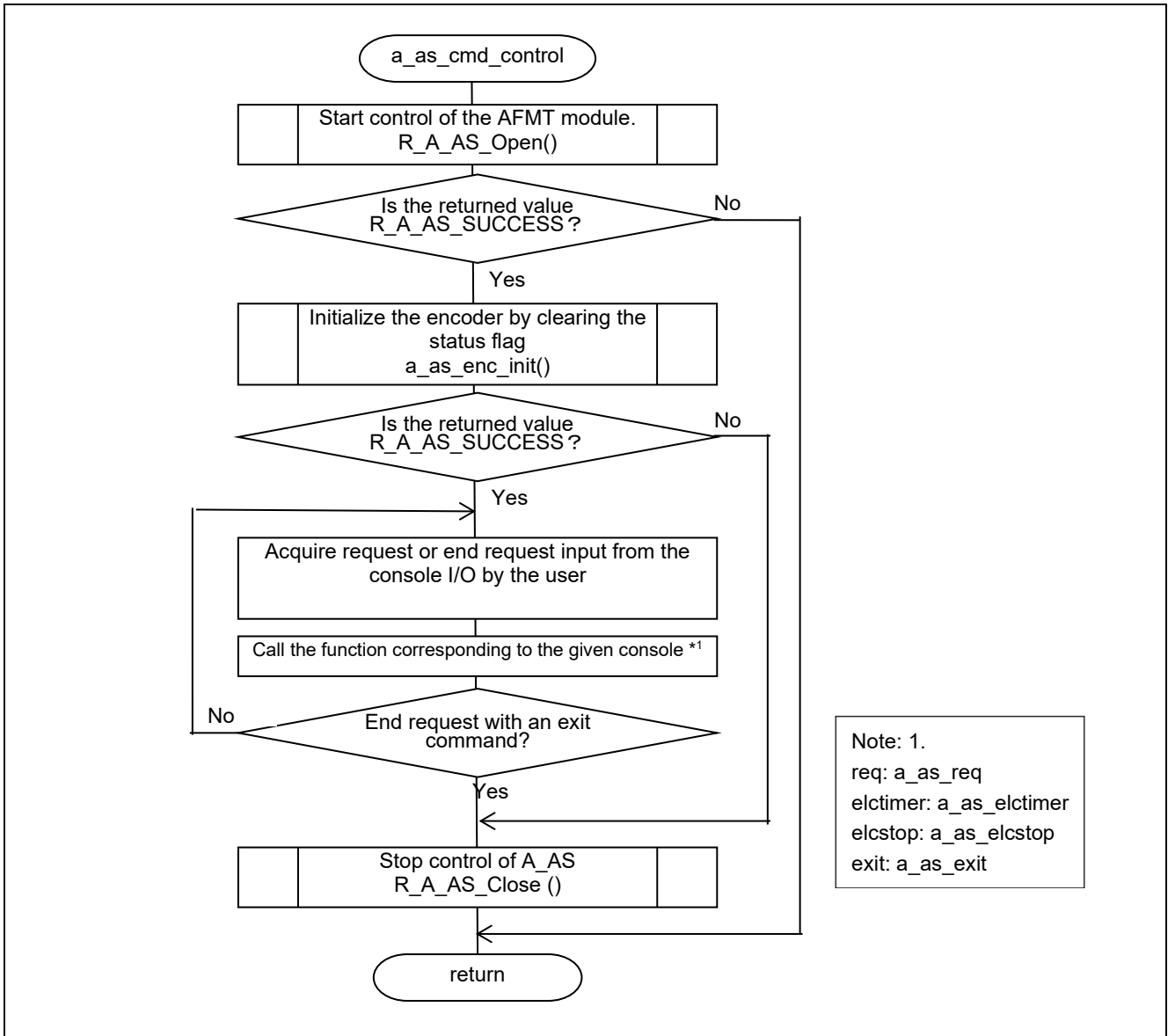

Figure 4.4 Flowchart of a_as_cmd_control

(3) Flowchart of a_as_req

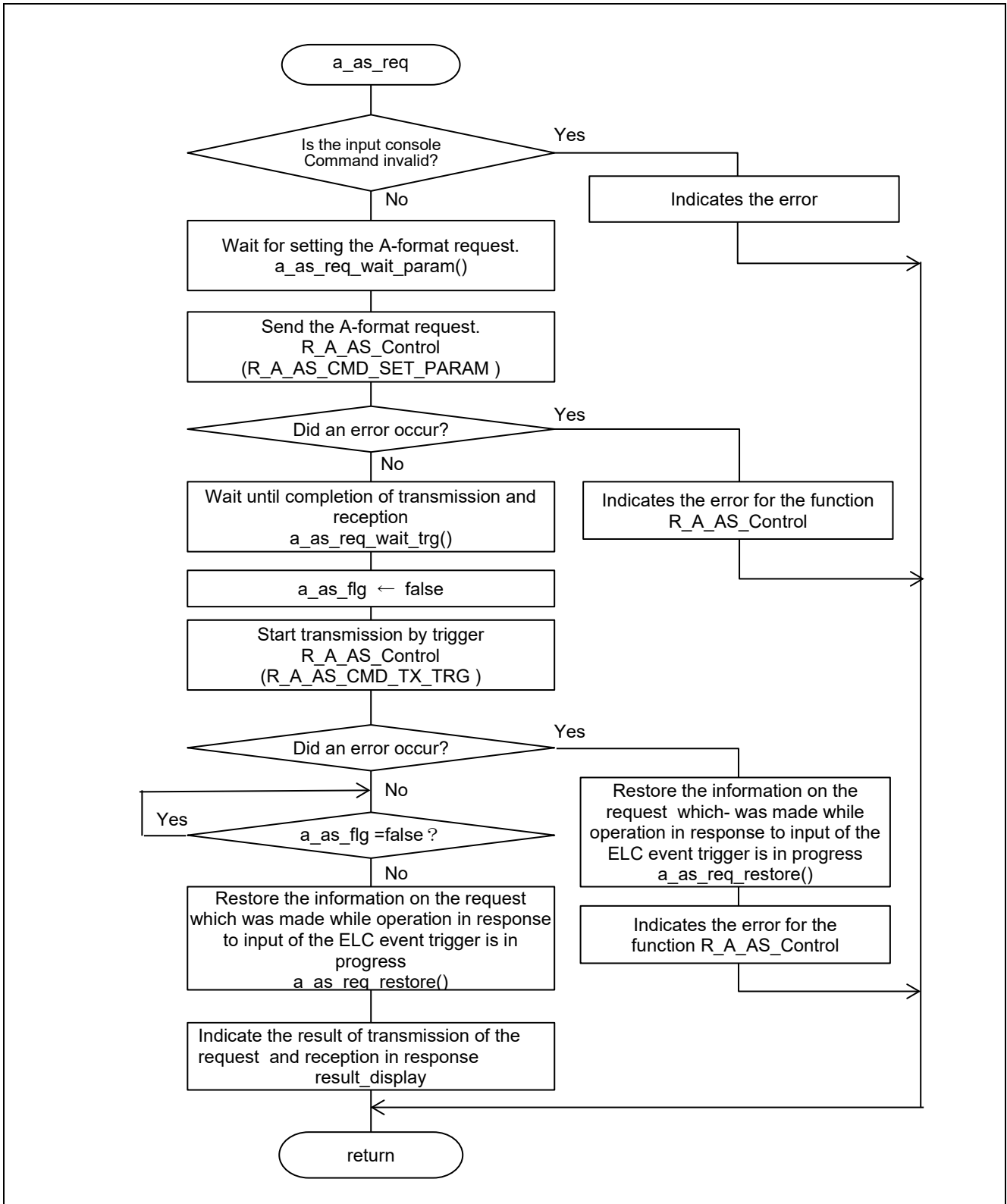

Figure 4.5 Flowchart of a_as_req

(4) Flowchart of a_as_elctimer

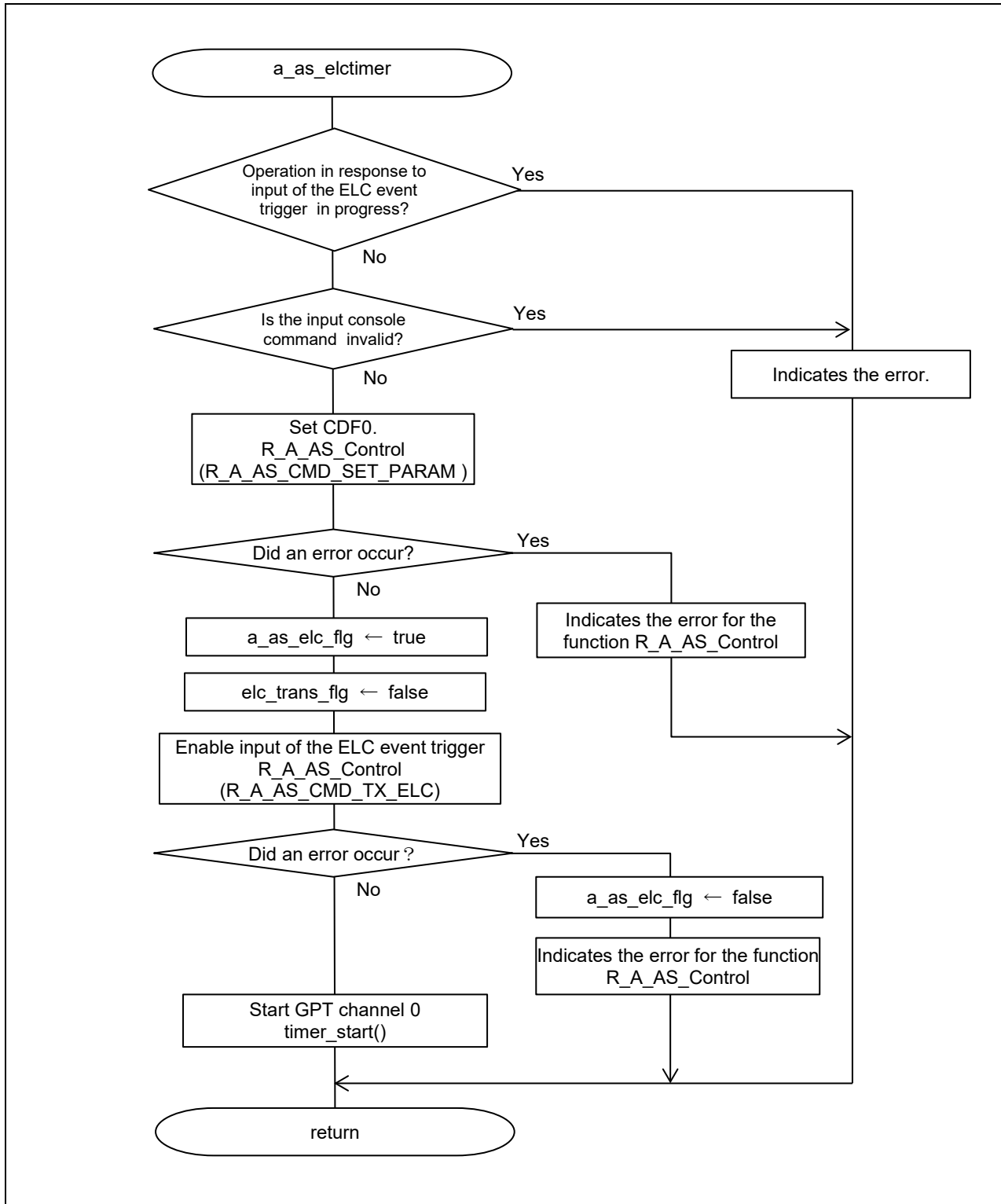

Figure 4.6 Flowchart of a_as_elctimer

(5) Flowchart of a_as_elcstop

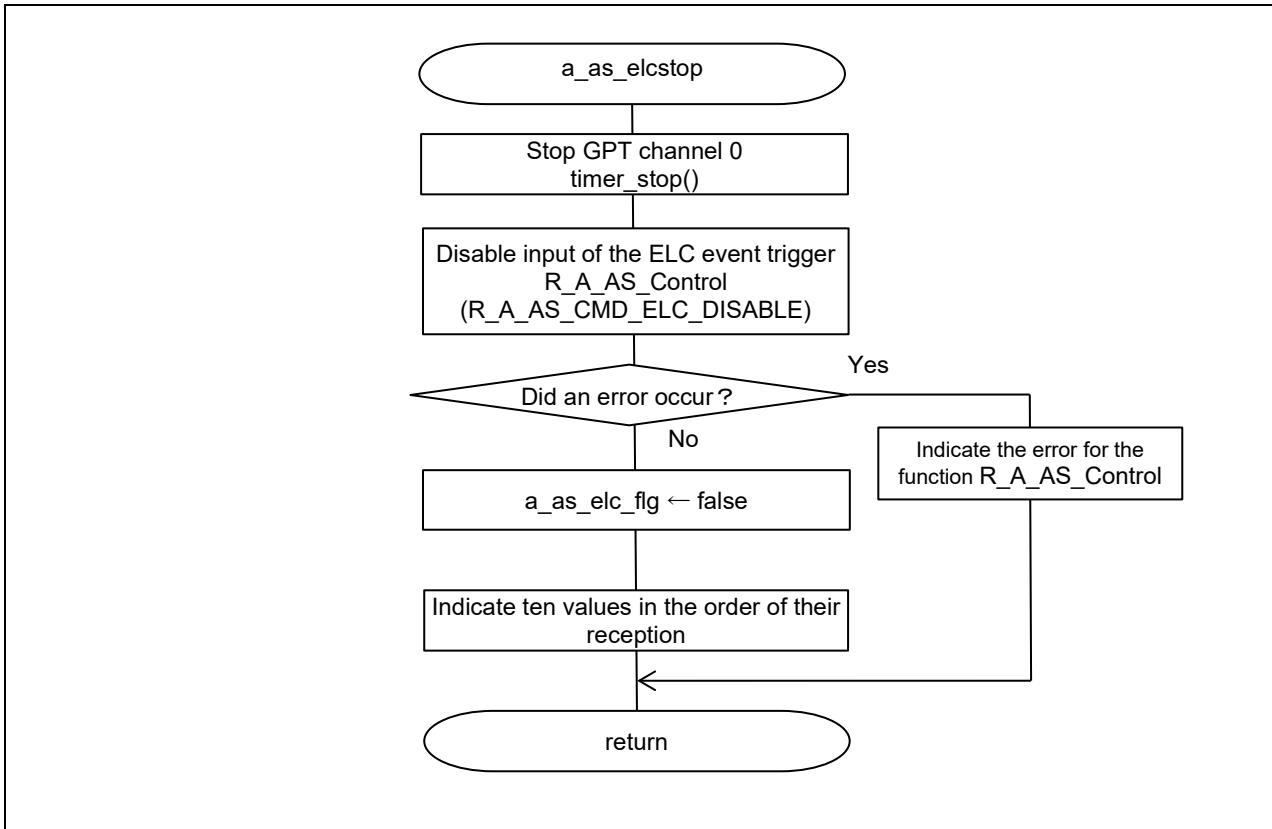

Figure 4.7 Flowchart of a_as_elcstop

(6) Flowchart of a_as_txerr_callback

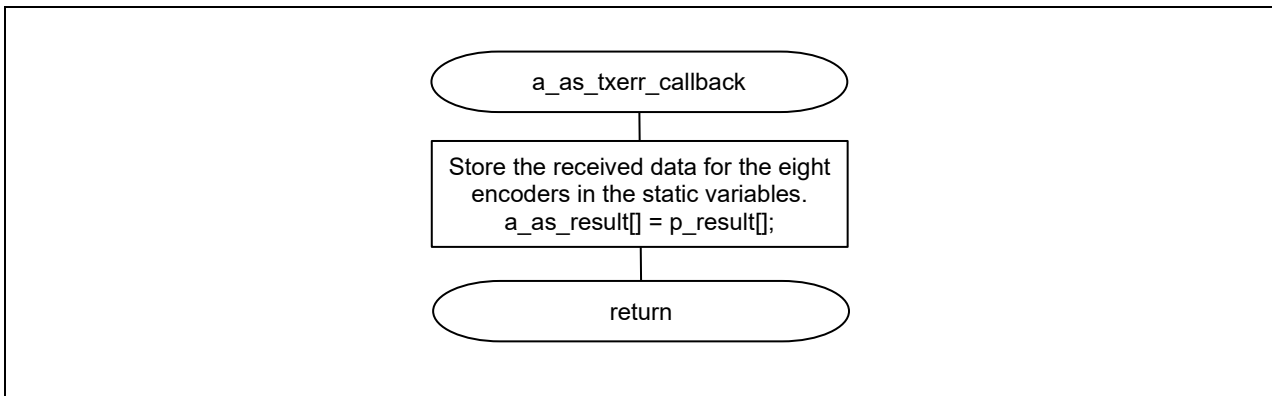

Figure 4.8 Flowchart of a_as_txerr_callback

(7) Flowchart of a_as_rxset_callback

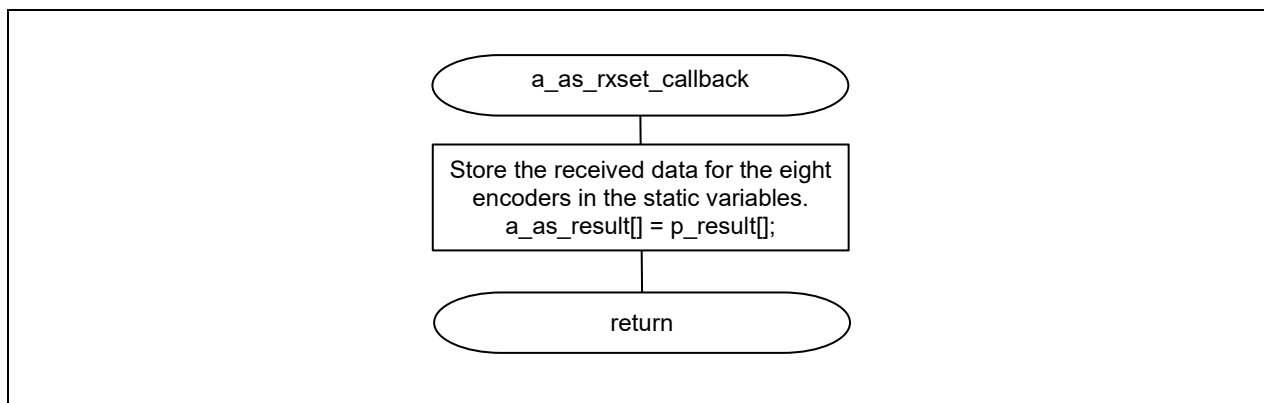

Figure 4.9 Flowchart of a_as_rxset_callback

(8) Flowchart of a_as_rxend_callback

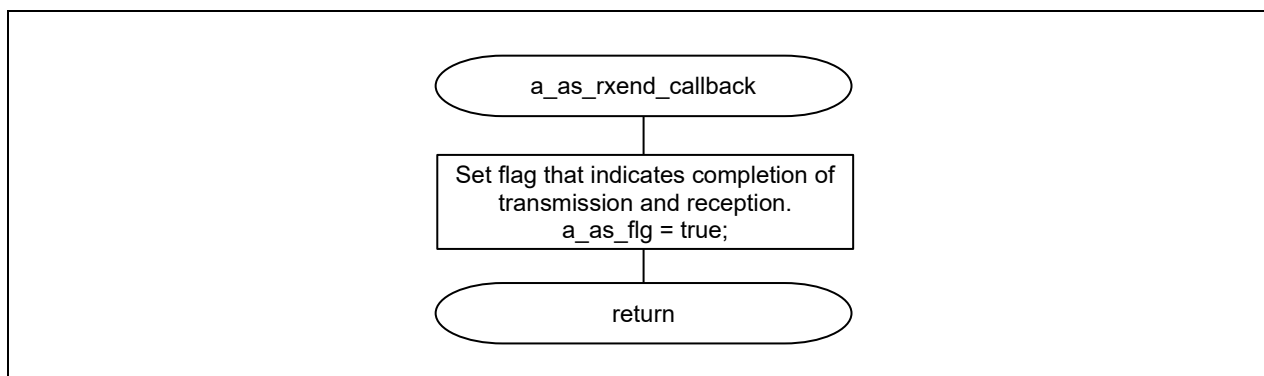

Figure 4.10 Flowchart of a_as_rxend_callback

(9) Flowchart of a_as_elctimer_callback

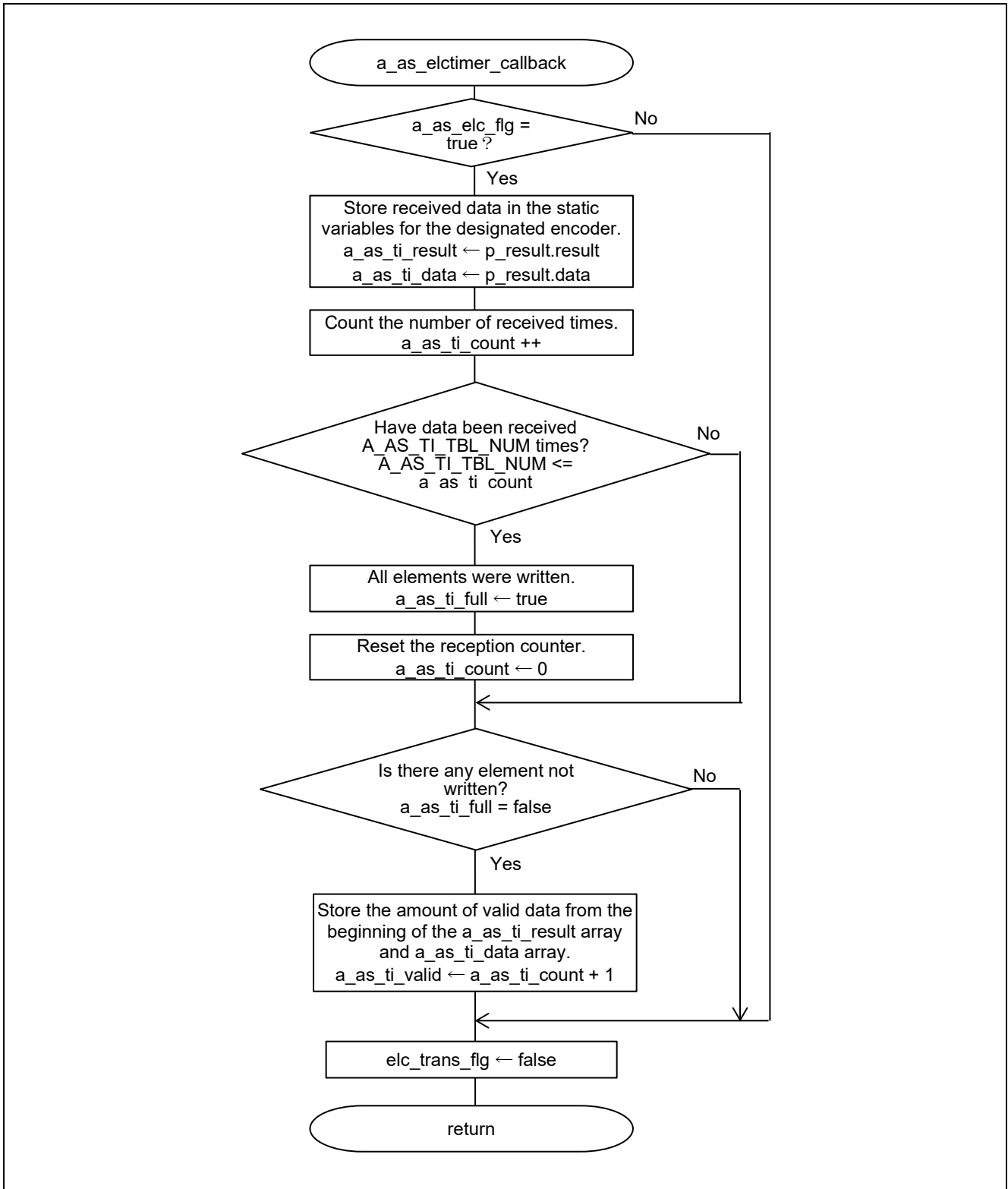

Figure 4.11 Flowchart of a_as_elctimer_callback

4.11.7 Operation Sequence

(1) Startup Sequence

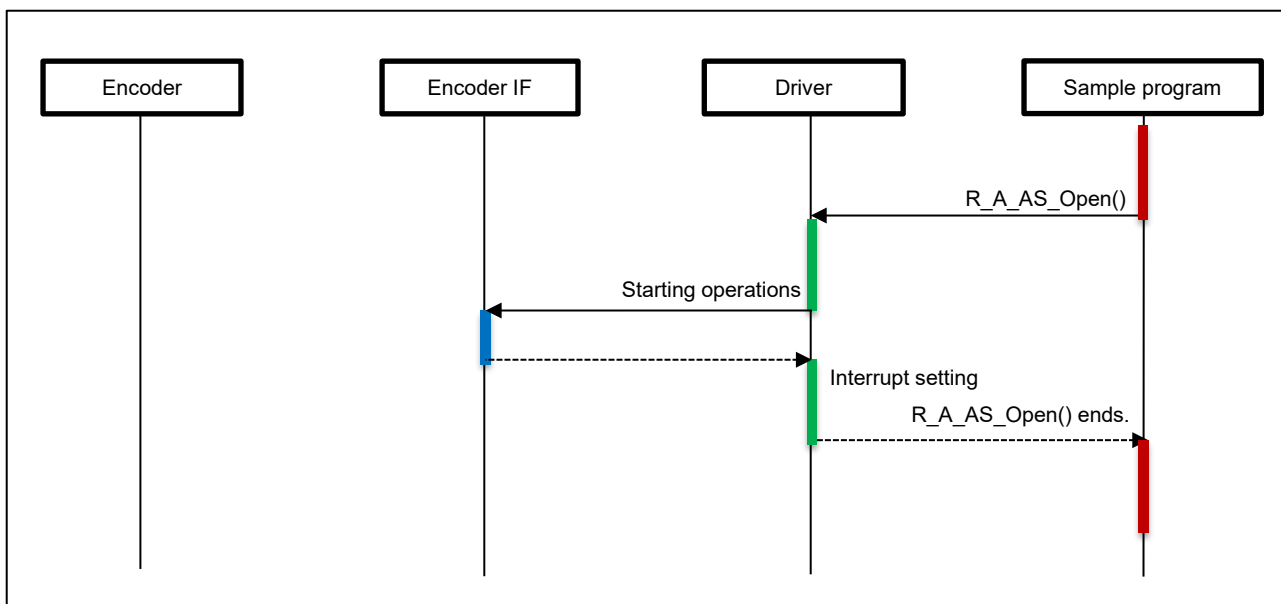

Figure 4.12 Startup Sequence Diagram

(2) Request Transmission and Data Reception Sequence

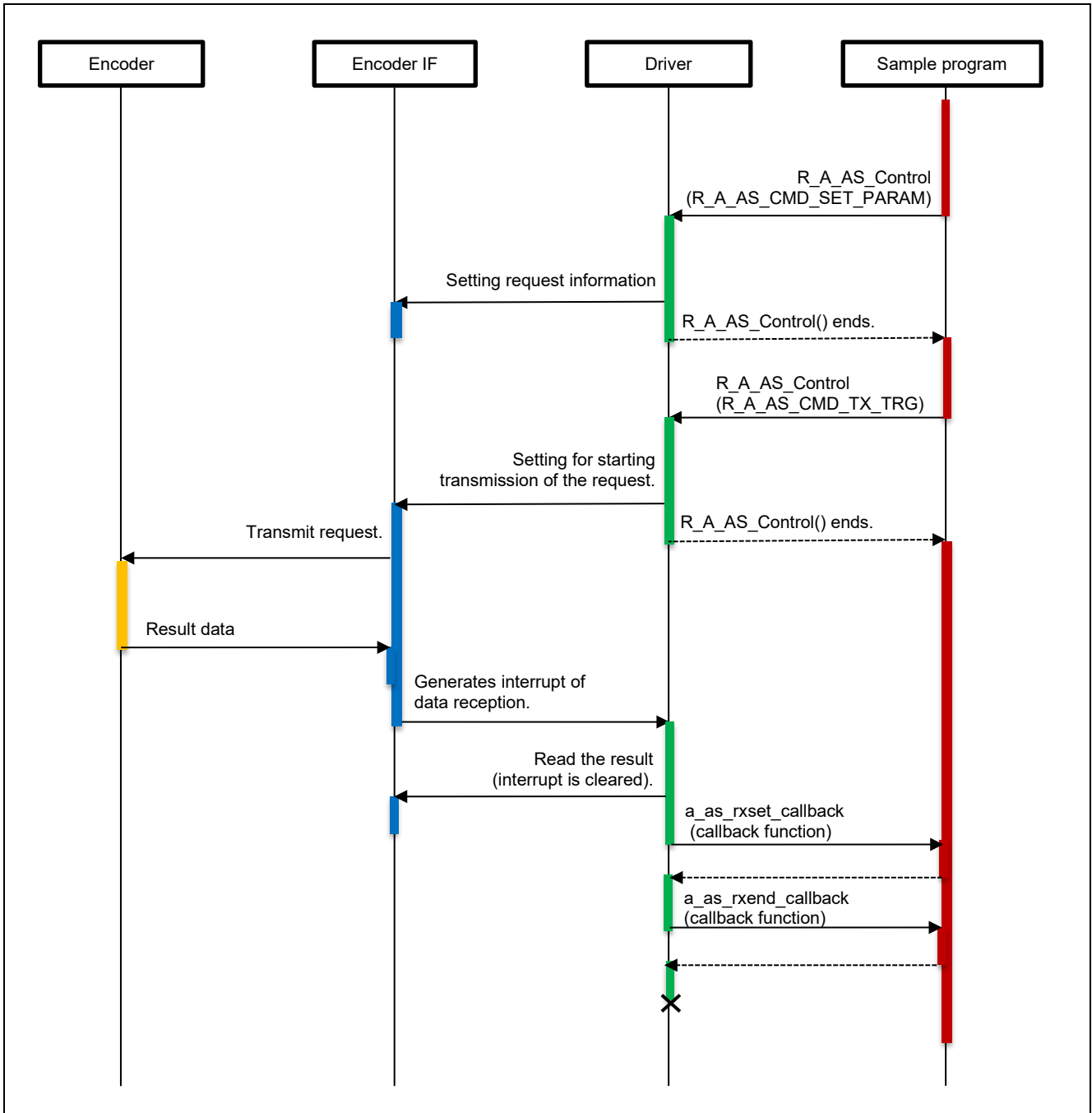

Figure 4.13 Request Transmission and Data Reception Sequence Diagram

(3) ELC Event Trigger Operation Sequence

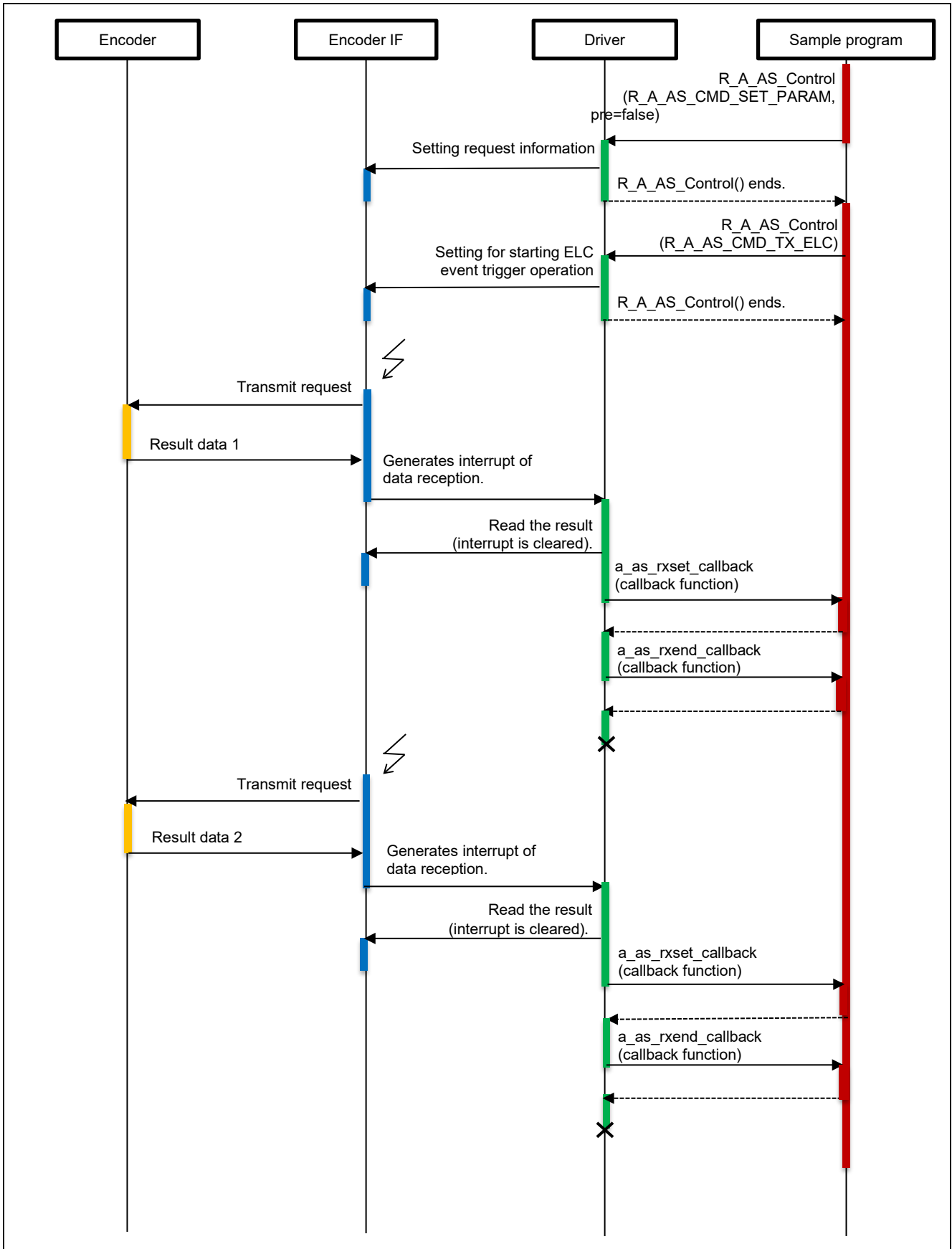

Figure 4.14 ELC Event Trigger Operation Sequence Diagram (1/2)

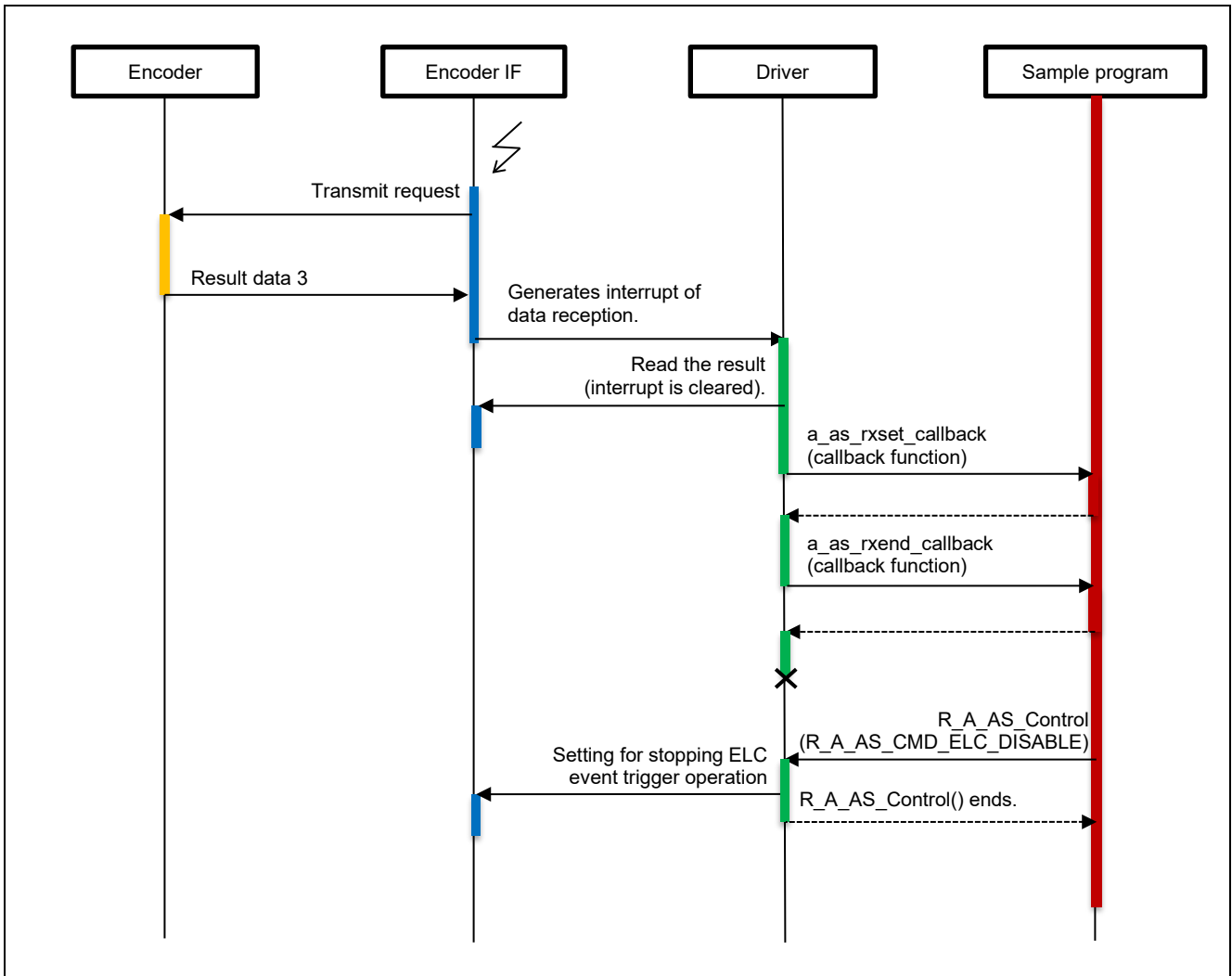

Figure 4.15 ELC Event Trigger Operation Sequence Diagram (2/2)

(4) Stop Sequence

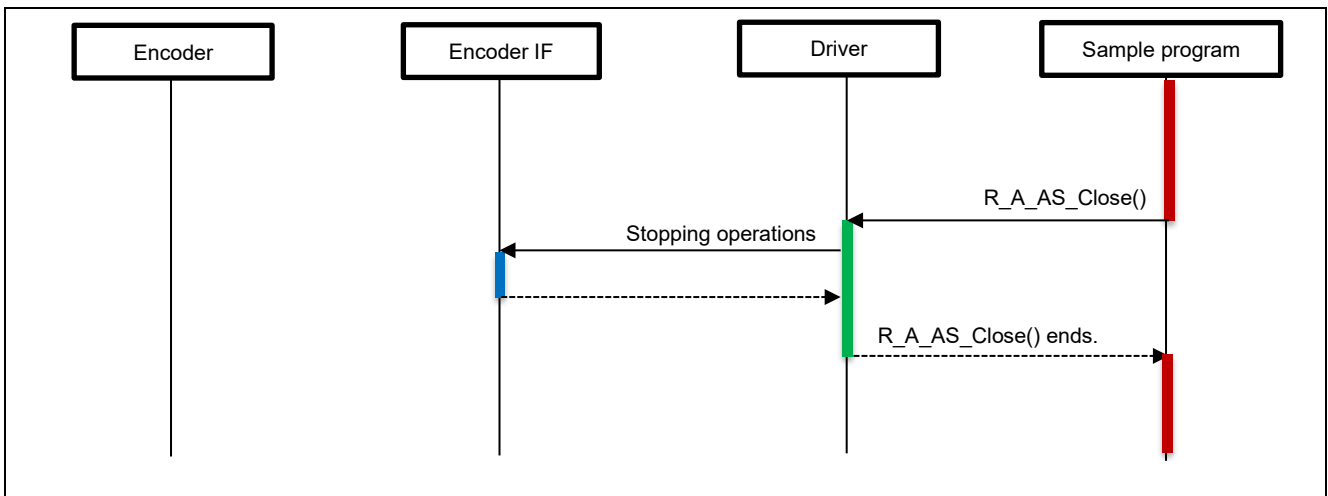

Figure 4.16 Stop Sequence Diagram

4.11.8 Console Commands

This sample program supports the MAR-M50A A-format-compliant encoders. The commands which can be input through the console are as follows.

Table 4.18 List of Console Commands

Command	Content
<code>req ea cmd param1 param2</code>	Sends the command frame input in the <i>cmd</i> to the encoder. <i>ea</i> : Encoder section number (decimal notation) <i>cmd</i> : Command frame <i>param1</i> and <i>param2</i> : The values to be input depends on the <i>cmd</i> value. See "Table 4.19 req Commands and Corresponding Parameters".
<code>elctimer ea val</code>	Sends the command frame CDF0 to the designated encoder at 2.5 Mbps by the ELC event trigger. <i>ea</i> : Encoder section number (decimal notation) <i>val</i> : Timing of the trigger in microseconds. The maximum value allowed is 6990. Operation in response to input of the ELC event trigger is stopped by executing the console command "elcstop".
<code>elcstop</code>	Stops the operation in response to input of the ELC event trigger.
<code>exit</code>	Exits the program.

Table 4.19 req Commands and Corresponding Parameters

cmd	param1	param2
CDF0 to CDF12	None	None
CDF13	An address in EEPROM (hexadecimal notation) Specify a value between 0x00 to 0xFF. Usage example (reading the data from address 0 of the encoder with section number 2) <code>req 2 CDF13 00</code>	None
CDF14	An address in EEPROM (in hexadecimal) Specify a value between 0x00 to 0xEF. Usage example (writing 0x1234 to address 0 of the encoder with section number 2) <code>req 2 CDF14 00 1234</code>	The data to be written to EEPROM (in hexadecimal) Specify a value between 0x0000 to 0xFFFF.
CDF15 to CDF17	None	None
CDF18, CDF19	ID code (in hexadecimal) Specify a value between 0x00 0000 to 0xFF FFFF. Usage example (writing ID code 0x12 3456 to the encoder with section number 2) <code>req 2 CDF18 123456</code>	None
CDF21, CDF27, CDF29	None	None

Note: Though input of CDF11, CDF17, and CDF19 are possible, they cannot be used because the sample program is for operation with a bus connection.

Multiple transmission commands (CDF4 to 7, CDF22, CDF28, CDF30) and CDF20 command are not supported.

(1) Result of running

After running, it will display the command prompt following the version. Enter the command after "a_as >".

```
A-format sample program start
R_A_AS_GetVersion = 4.0

a_as >
```

(2) Example of command execution

It is an example of executing console command that sends command frame CDF0 to a connecting encoder ENC1. Encoder address, status and angular information are reported as the response from the encoder.

```
a_as >req 1 CDF0
req command
-----
ENC1
R_A_AS_REQ_SUCCESS
EA : 0
ES : 0
CC : 0
ABS 40bit [39:32] : 0x00000005
ABS 40bit [31:0] : 0x00560E11
```

5. Sample Code

The sample program is available on the Renesas Electronics website.

Revision History

Rev.	Date	Description	
		Page	Summary
2.00	Dec 23.24	-	First Edition issued.
3.00	Nov 07.25	1, 4, 5 13 to 17 29	Change description for trademarks. Remove description of unsupported timer operation. Revise description of structure r_a_as_status_t.
4.00	Apr 24.26	5 9 to 18, 35 to 37 14 to 17	Change the frequency of the Cortex-A55 Core0 to 1200MHz. Change the prefix of pointer variables to "p_". Revised the header column of "4.5 Specifications of User-defined Function".

General Precautions in the Handling of Microprocessing Unit and Microcontroller Unit Products

The following usage notes are applicable to all Microprocessing unit and Microcontroller unit products from Renesas. For detailed usage notes on the products covered by this document, refer to the relevant sections of the document as well as any technical updates that have been issued for the products.

1. Precaution against Electrostatic Discharge (ESD)

A strong electrical field, when exposed to a CMOS device, can cause destruction of the gate oxide and ultimately degrade the device operation. Steps must be taken to stop the generation of static electricity as much as possible, and quickly dissipate it when it occurs. Environmental control must be adequate. When it is dry, a humidifier should be used. This is recommended to avoid using insulators that can easily build up static electricity.

Semiconductor devices must be stored and transported in an anti-static container, static shielding bag or conductive material. All test and measurement tools including work benches and floors must be grounded. The operator must also be grounded using a wrist strap. Semiconductor devices must not be touched with bare hands. Similar precautions must be taken for printed circuit boards with mounted semiconductor devices.

2. Processing at power-on

The state of the product is undefined at the time when power is supplied. The states of internal circuits in the LSI are indeterminate and the states of register settings and pins are undefined at the time when power is supplied. In a finished product where the reset signal is applied to the external reset pin, the states of pins are not guaranteed from the time when power is supplied until the reset process is completed. In a similar way, the states of pins in a product that is reset by an on-chip power-on reset function are not guaranteed from the time when power is supplied until the power reaches the level at which resetting is specified.

3. Input of signal during power-off state

Do not input signals or an I/O pull-up power supply while the device is powered off. The current injection that results from input of such a signal or I/O pull-up power supply may cause malfunction and the abnormal current that passes in the device at this time may cause degradation of internal elements. Follow the guideline for input signal during power-off state as described in your product documentation.

4. Handling of unused pins

Handle unused pins in accordance with the directions given under handling of unused pins in the manual. The input pins of CMOS products are generally in the high-impedance state. In operation with an unused pin in the open-circuit state, extra electromagnetic noise is induced in the vicinity of the LSI, an associated shoot-through current flows internally, and malfunctions occur due to the false recognition of the pin state as an input signal become possible.

5. Clock signals

After applying a reset, only release the reset line after the operating clock signal becomes stable. When switching the clock signal during program execution, wait until the target clock signal is stabilized. When the clock signal is generated with an external resonator or from an external oscillator during a reset, ensure that the reset line is only released after full stabilization of the clock signal. Additionally, when switching to a clock signal produced with an external resonator or by an external oscillator while program execution is in progress, wait until the target clock signal is stable.

6. Voltage application waveform at input pin

Waveform distortion due to input noise or a reflected wave may cause malfunction. If the input of the CMOS device stays in the area between V_{IL} (Max.) and V_{IH} (Min.) due to noise, for example, the device may malfunction. Take care to prevent chattering noise from entering the device when the input level is fixed, and also in the transition period when the input level passes through the area between V_{IL} (Max.) and V_{IH} (Min.).

7. Prohibition of access to reserved addresses

Access to reserved addresses is prohibited. The reserved addresses are provided for possible future expansion of functions. Do not access these addresses as the correct operation of the LSI is not guaranteed.

8. Differences between products

Before changing from one product to another, for example to a product with a different part number, confirm that the change will not lead to problems. The characteristics of a microprocessing unit or microcontroller unit products in the same group but having a different part number might differ in terms of internal memory capacity, layout pattern, and other factors, which can affect the ranges of electrical characteristics, such as characteristic values, operating margins, immunity to noise, and amount of radiated noise. When changing to a product with a different part number, implement a system-evaluation test for the given product.

- A-format is a trademark of Nikon Corporation.
- IAR Embedded Workbench is a registered trademark of IAR Systems.
- Arm and Cortex are registered trademarks of Arm Limited (or its subsidiaries) in the EU and/or elsewhere. All rights reserved.
- Additionally all product names and service names in this document are a trademark or a registered trademark which belongs to the respective owners.

Notice

1. Descriptions of circuits, software and other related information in this document are provided only to illustrate the operation of semiconductor products and application examples. You are fully responsible for the incorporation or any other use of the circuits, software, and information in the design of your product or system. Renesas Electronics disclaims any and all liability for any losses and damages incurred by you or third parties arising from the use of these circuits, software, or information.
2. Renesas Electronics hereby expressly disclaims any warranties against and liability for infringement or any other claims involving patents, copyrights, or other intellectual property rights of third parties, by or arising from the use of Renesas Electronics products or technical information described in this document, including but not limited to, the product data, drawings, charts, programs, algorithms, and application examples.
3. No license, express, implied or otherwise, is granted hereby under any patents, copyrights or other intellectual property rights of Renesas Electronics or others.
4. You shall be responsible for determining what licenses are required from any third parties, and obtaining such licenses for the lawful import, export, manufacture, sales, utilization, distribution or other disposal of any products incorporating Renesas Electronics products, if required.
5. You shall not alter, modify, copy, or reverse engineer any Renesas Electronics product, whether in whole or in part. Renesas Electronics disclaims any and all liability for any losses or damages incurred by you or third parties arising from such alteration, modification, copying or reverse engineering.
6. Renesas Electronics products are classified according to the following two quality grades: "Standard" and "High Quality". The intended applications for each Renesas Electronics product depends on the product's quality grade, as indicated below.
 - "Standard": Computers; office equipment; communications equipment; test and measurement equipment; audio and visual equipment; home electronic appliances; machine tools; personal electronic equipment; industrial robots; etc.
 - "High Quality": Transportation equipment (automobiles, trains, ships, etc.); traffic control (traffic lights); large-scale communication equipment; key financial terminal systems; safety control equipment; etc.Unless expressly designated as a high reliability product or a product for harsh environments in a Renesas Electronics data sheet or other Renesas Electronics document, Renesas Electronics products are not intended or authorized for use in products or systems that may pose a direct threat to human life or bodily injury (artificial life support devices or systems; surgical implantations; etc.), or may cause serious property damage (space system; undersea repeaters; nuclear power control systems; aircraft control systems; key plant systems; military equipment; etc.). Renesas Electronics disclaims any and all liability for any damages or losses incurred by you or any third parties arising from the use of any Renesas Electronics product that is inconsistent with any Renesas Electronics data sheet, user's manual or other Renesas Electronics document.
7. No semiconductor product is absolutely secure. Notwithstanding any security measures or features that may be implemented in Renesas Electronics hardware or software products, Renesas Electronics shall have absolutely no liability arising out of any vulnerability or security breach, including but not limited to any unauthorized access to or use of a Renesas Electronics product or a system that uses a Renesas Electronics product. RENESAS ELECTRONICS DOES NOT WARRANT OR GUARANTEE THAT RENESAS ELECTRONICS PRODUCTS, OR ANY SYSTEMS CREATED USING RENESAS ELECTRONICS PRODUCTS WILL BE INVULNERABLE OR FREE FROM CORRUPTION, ATTACK, VIRUSES, INTERFERENCE, HACKING, DATA LOSS OR THEFT, OR OTHER SECURITY INTRUSION ("Vulnerability Issues"). RENESAS ELECTRONICS DISCLAIMS ANY AND ALL RESPONSIBILITY OR LIABILITY ARISING FROM OR RELATED TO ANY VULNERABILITY ISSUES. FURTHERMORE, TO THE EXTENT PERMITTED BY APPLICABLE LAW, RENESAS ELECTRONICS DISCLAIMS ANY AND ALL WARRANTIES, EXPRESS OR IMPLIED, WITH RESPECT TO THIS DOCUMENT AND ANY RELATED OR ACCOMPANYING SOFTWARE OR HARDWARE, INCLUDING BUT NOT LIMITED TO THE IMPLIED WARRANTIES OF MERCHANTABILITY, OR FITNESS FOR A PARTICULAR PURPOSE.
8. When using Renesas Electronics products, refer to the latest product information (data sheets, user's manuals, application notes, "General Notes for Handling and Using Semiconductor Devices" in the reliability handbook, etc.), and ensure that usage conditions are within the ranges specified by Renesas Electronics with respect to maximum ratings, operating power supply voltage range, heat dissipation characteristics, installation, etc. Renesas Electronics disclaims any and all liability for any malfunctions, failure or accident arising out of the use of Renesas Electronics products outside of such specified ranges.
9. Although Renesas Electronics endeavors to improve the quality and reliability of Renesas Electronics products, semiconductor products have specific characteristics, such as the occurrence of failure at a certain rate and malfunctions under certain use conditions. Unless designated as a high reliability product or a product for harsh environments in a Renesas Electronics data sheet or other Renesas Electronics document, Renesas Electronics products are not subject to radiation resistance design. You are responsible for implementing safety measures to guard against the possibility of bodily injury, injury or damage caused by fire, and/or danger to the public in the event of a failure or malfunction of Renesas Electronics products, such as safety design for hardware and software, including but not limited to redundancy, fire control and malfunction prevention, appropriate treatment for aging degradation or any other appropriate measures. Because the evaluation of microcomputer software alone is very difficult and impractical, you are responsible for evaluating the safety of the final products or systems manufactured by you.
10. Please contact a Renesas Electronics sales office for details as to environmental matters such as the environmental compatibility of each Renesas Electronics product. You are responsible for carefully and sufficiently investigating applicable laws and regulations that regulate the inclusion or use of controlled substances, including without limitation, the EU RoHS Directive, and using Renesas Electronics products in compliance with all these applicable laws and regulations. Renesas Electronics disclaims any and all liability for damages or losses occurring as a result of your noncompliance with applicable laws and regulations.
11. Renesas Electronics products and technologies shall not be used for or incorporated into any products or systems whose manufacture, use, or sale is prohibited under any applicable domestic or foreign laws or regulations. You shall comply with any applicable export control laws and regulations promulgated and administered by the governments of any countries asserting jurisdiction over the parties or transactions.
12. It is the responsibility of the buyer or distributor of Renesas Electronics products, or any other party who distributes, disposes of, or otherwise sells or transfers the product to a third party, to notify such third party in advance of the contents and conditions set forth in this document.
13. This document shall not be reprinted, reproduced or duplicated in any form, in whole or in part, without prior written consent of Renesas Electronics.
14. Please contact a Renesas Electronics sales office if you have any questions regarding the information contained in this document or Renesas Electronics products.

(Note1) "Renesas Electronics" as used in this document means Renesas Electronics Corporation and also includes its directly or indirectly controlled subsidiaries.

(Note2) "Renesas Electronics product(s)" means any product developed or manufactured by or for Renesas Electronics.

(Rev.5.0-1 October 2020)

Corporate Headquarters

TOYOSU FORESIA, 3-2-24 Toyosu,
Koto-ku, Tokyo 135-0061, Japan
www.renesas.com

Trademarks

Renesas and the Renesas logo are trademarks of Renesas Electronics Corporation. All trademarks and registered trademarks are the property of their respective owners.

Contact information

For further information on a product, technology, the most up-to-date version of a document, or your nearest sales office, please visit:
www.renesas.com/contact/.