

Contents

1. Introduction.....2

2. Application Configuration.....4

 2.1 Output Voltage Adjustment V_{OUT}5

 2.2 Setup for the ZSC31050 Evaluation Board.....6

3. Document Revision History7

List of Figures

Figure 1. Ratiometric, 0V to 10V Analog Output, and 4 to 20mA Current Loop Schematic.....2

Figure 2. ZSC31050 Evaluation Kit Equivalent Schematic.....4

Figure 3. Calibration Window.....5

Figure 4. ZSC31050 Evaluation Board Settings6

List of Tables

Table 1. Parameters for External Components depending on Output Configuration3

1. Introduction

In the circuit design described in this application note, the analog output voltage of the ZSC31050 is shifted into the range of 0 to 10 VDC by external circuitry creating a voltage-to-current-to-voltage converter consisting of four resistors (R5, R6, R7, and RC2), a capacitor (RC1), and two bipolar transistors (T2 and T3) as shown in Figure 1.

T2 is a common NPN-type transistor (e.g., BC817-40); there are no special requirements to be considered. T3 is a PNP-type transistor; the type depends on the power dissipation at the maximum ambient temperature T_{AMB_max} with the maximum supply voltage V_{SUPP_max} , the maximum output load current I_{OUT_max} , and the output voltage V_{OUT} . The required power dissipation rating for T3 at T_{AMB_max} can be calculated using equation (1).

$$P_{T3_max}(T_{AMB_max}) \geq \left(I_{OUT_max} + \frac{V_{OUT_max}}{R7 + RC2} \right) * (V_{SUPP_max} - V_{OUT_max}) \tag{1}$$

Figure 1 provides the basic schematic for this application. V_{OUT_NR} is the non-ratiometric output voltage. See Table 1 for details for external components. Note that component values vary depending on the output configuration.

With the current loop output, the analog 2-wire-interface is connected to V+ and V-. The ZACwire™ (one-wire; OWI) interface communicates via V_{OUT} referenced to VSS using an isolated communication module with a pull-up resistor at V_{OUT} , which is supplied by a voltage equal to VDDA. For more details regarding current-loop applications and the ZACwire™ interface, refer to the *ZSC31050 Application Note – Two-Wire Current Loop Output*.

With all analog voltage output configurations, V- is shorted to VSS via $R3 = 0 \Omega$.

For protection against reverse polarity at low voltage drops, a PMOS-enhancement transistor with sufficient gate-to-source voltage could be used instead of D1 or R1.

Figure 1. Ratiometric, 0V to 10V Analog Output, and 4 to 20mA Current Loop Schematic

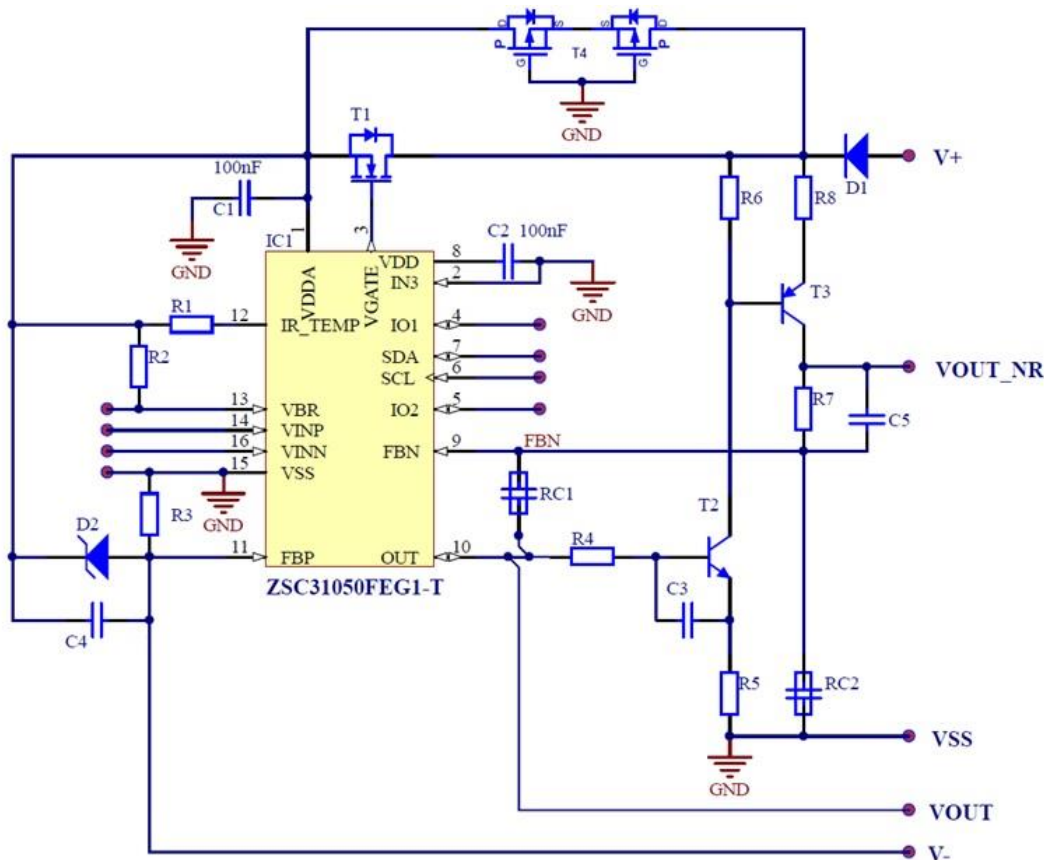

Table 1. Parameters for External Components depending on Output Configuration

Part ID	Ratiometric Output	Non-ratiometric Output (0V to 10V)	4 to 20mA Current Loop
R1	For bridge in current excitation mode only		
R2	For bridge in voltage excitation (from VDDA) mode only		
R3	0Ω	0Ω	50Ω
R4	Not placed	2.2kΩ	2.2kΩ
R5	Not placed	1kΩ	150Ω
R6	Not placed	390Ω	0Ω
R7	0Ω	2.2kΩ	Not placed
R8	Not placed	Typical 150 Ω (for current limitation)	Not placed
RC1	0Ω	100nF	Not placed
RC2	15nF	2kΩ	0Ω
C1	100nF		
C2	100nF		
C3	Not placed	220pF	220pF
C4	Not placed	10nF	10nF
C5	Not placed	100nF	Not placed
D1	Not placed	LL4148	LL4148
D2	Not placed	BZV55C6V8	BZV55B7V5
T1	Not placed	BSS169N	BSS169N
T2	Not placed	BC817-40 (SOT23)	BC817-40 (SOT23)
T3	Not placed	BC807-40 (SOT23)	Not placed
T4	FDC6306P	Not placed	Not placed

2. Application Configuration

The configuration is determined by the programming of the ZSC31050 and by the placement and value of the external parts given in the schematics in Figure 1 and Table 1. The ZSC31050 SSC Evaluation Kit can be used to program the ZSC31050 as needed for one of the output configurations. The SSC Communication Board included in the ZSC31050 SSC Evaluation Kit can be connected to the application circuit shown in Figure 1 to provide a communication interface for programming the ZSC31050. For full details for connections, programming and configuration of the ZSC31050 with the SSC Evaluation Kit, see the *ZSC31050 Evaluation Kit Description*.

Figure 2 provides a schematic that is equivalent to the Evaluation Board schematic provided in the *ZSC31050 Evaluation Kit Description*. Jumpers and switches are replaced with resistors for easier tests and prototyping.

Figure 2. ZSC31050 Evaluation Kit Equivalent Schematic

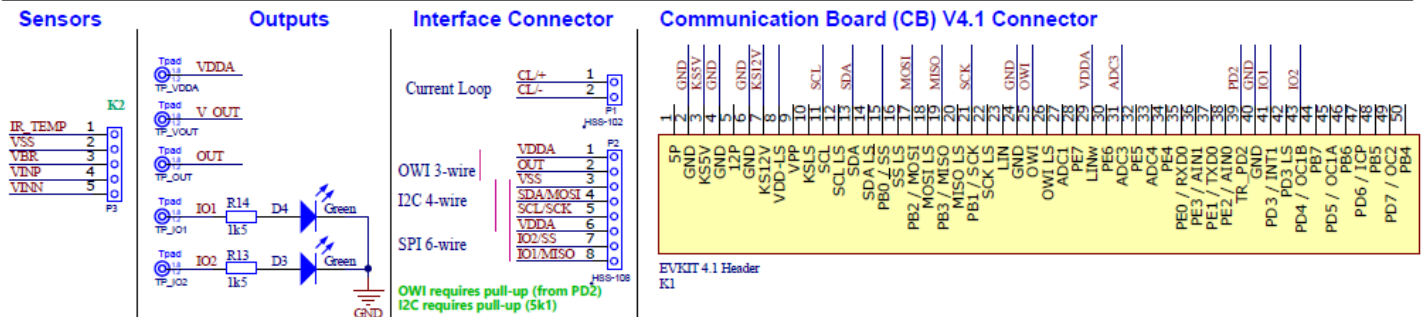
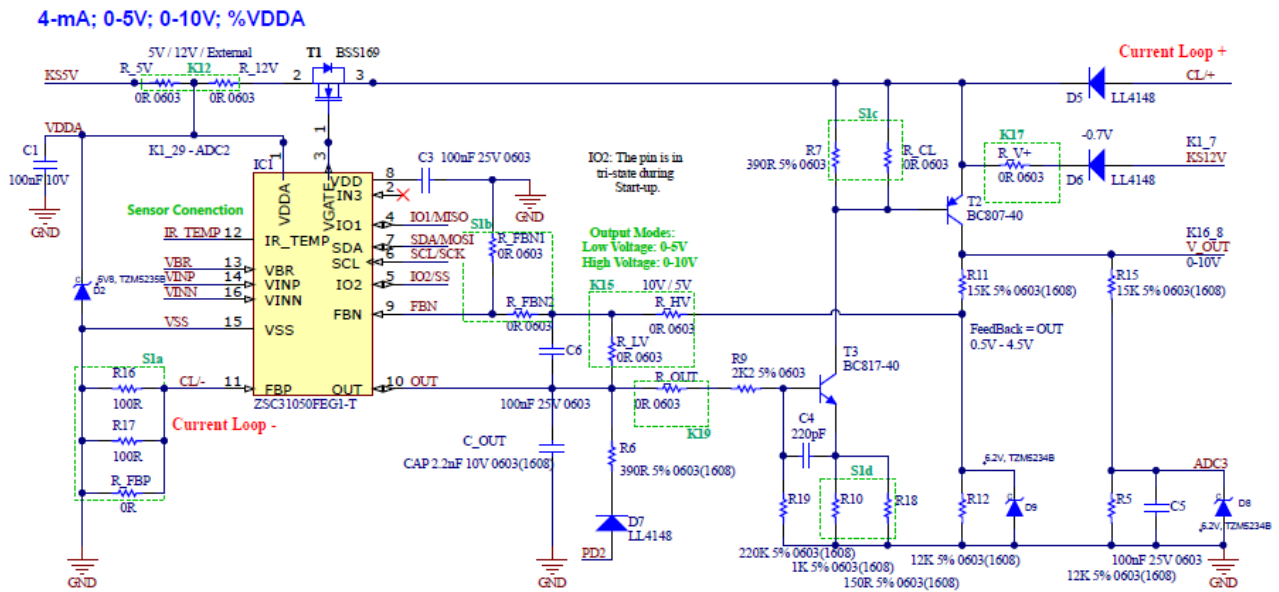

2.1 Output Voltage Adjustment V_{OUT}

The following procedures will compensate components' parameter variations in order to achieve the desired output voltage range of 0 to 10V.

- Calibration and coefficient calculation (initial targets: 10% and 90%)
- Analog output measurement
- Re-adjustment of target values (manual calculation via equation (2)) and limit values and then calculation of the new coefficients

$$New_Target = Initial_Target - \left(\frac{V_{OUT} - V_{SET}}{V_{SET_MAX} - V_{SET_MIN}} \right) * (Target_max\% - Target_min\%) \tag{2}$$

Where

V_{OUT} = the measured voltage

V_{SET} = the target voltage

V_{SET_MAX} = the target maximum voltage

V_{SET_MIN} = target minimum voltage

For example, re-calculation of the maximum target can be done based on the measured output 10.15V and initial calibration targets 10% and 90% as demonstrated in equation (3):

$$New_Target = 90\% - \left(\frac{10.15V - 10V}{10V - 0V} \right) * (90\% - 10\%) = 88.8\% \tag{3}$$

Calibrating with a target of 0% (0V) is not reliable in practice; therefore, to adjust the minimum calibration target, the sensor signal can be set to a level that results in a 10% output (measured as 1.11V in this example). After raw data acquisition, equation (2) for calculating the adjusted targets can be applied for fine-tuning the output.

Figure 3. Calibration Window

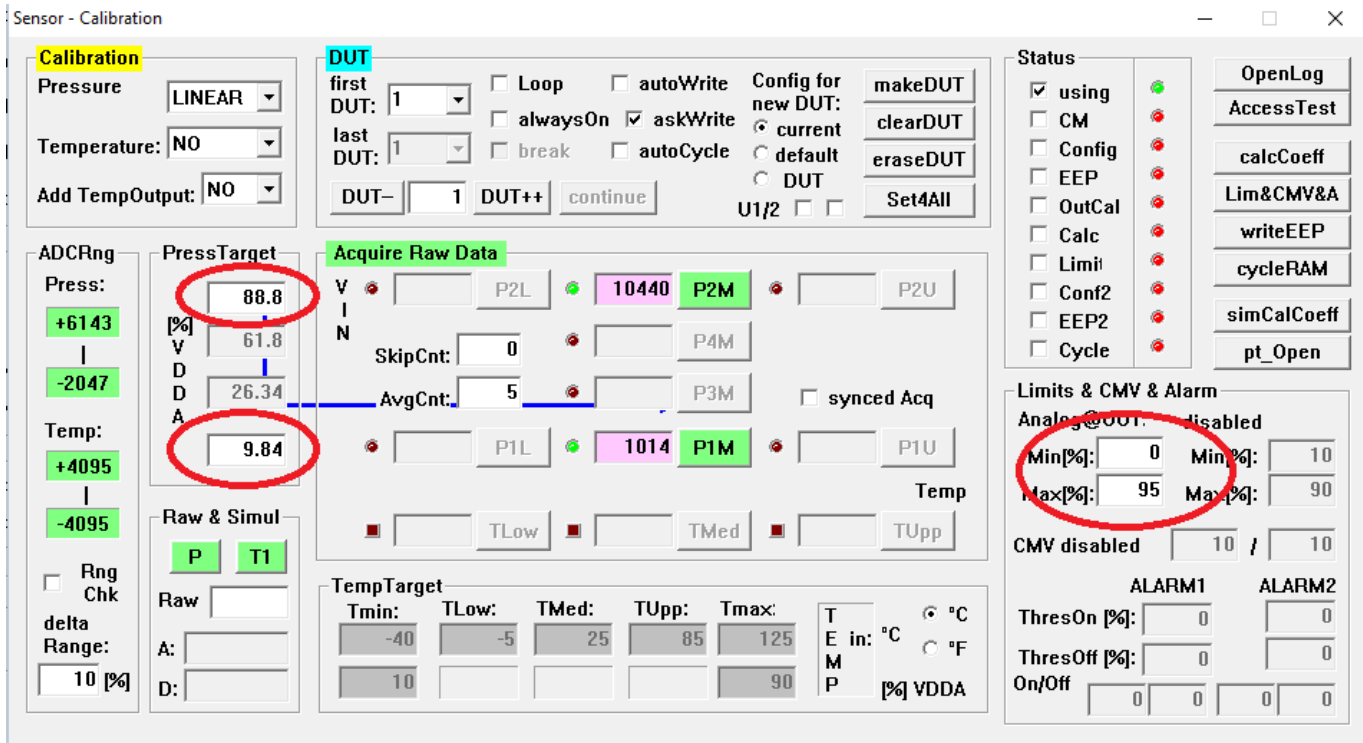

2.2 Setup for the ZSC31050 Evaluation Board

Set the switches and jumpers on the SSC Evaluation Board according to Figure 4.

Figure 4. ZSC31050 Evaluation Board Settings

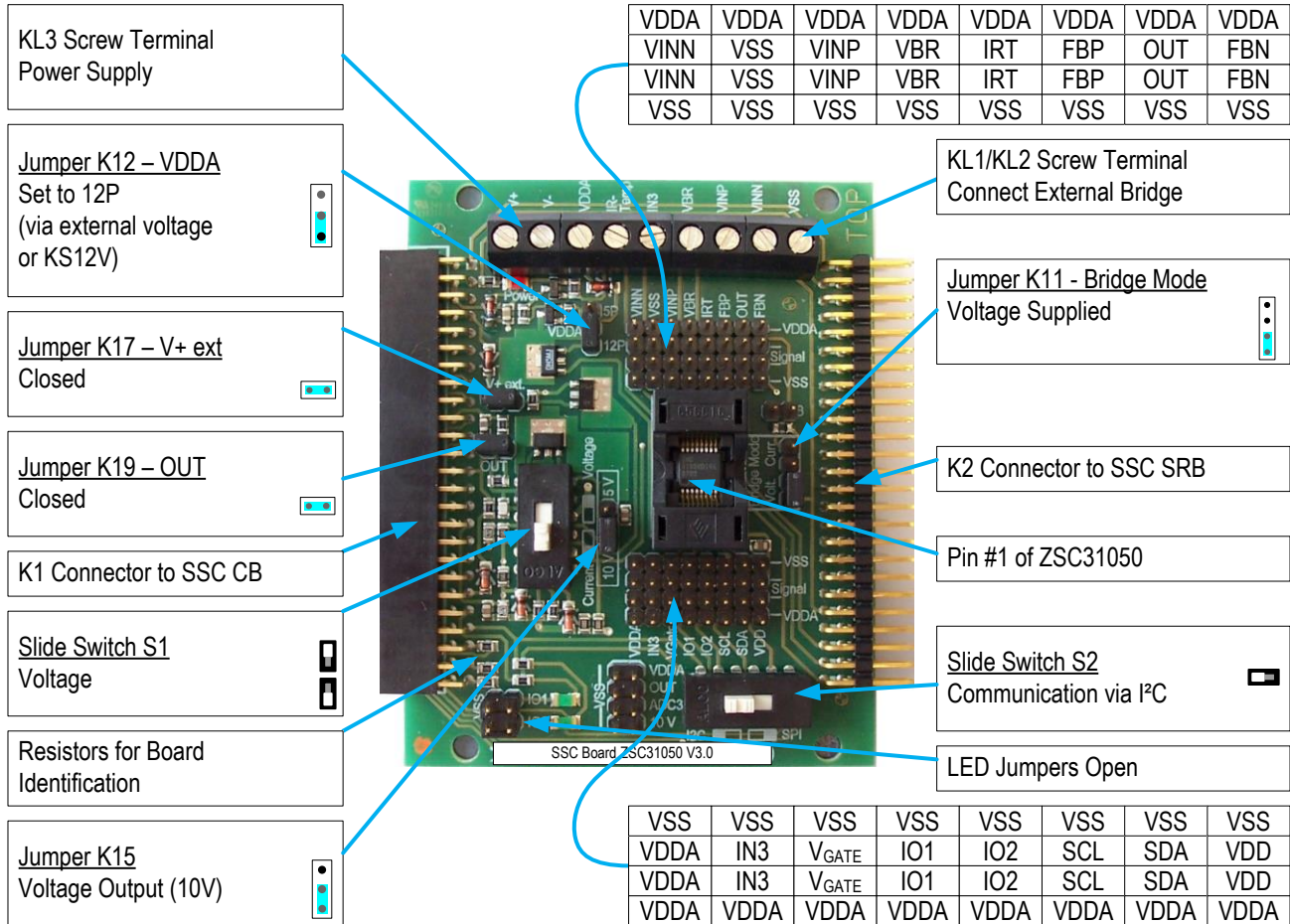

3. Document Revision History

Revision Date	Description of Change
August 22, 2017	<ul style="list-style-type: none"> ▪ Removal of content regarding the configuration for 3-wire 0-10V output with OWI applications, which will be provided in a pending separate document. ▪ Addition of Figure 2 and introductory text. ▪ Minor edits.
April 26, 2017	Changed to IDT branding.
October 14, 2013 (Revision 2.10)	Addition of sections 2.3, 2.4, and 2.5 Update to "Related Documents" section to add example Gerber files available on the IDT website. Update for Figure 2.3. Update for Table 3.1. Minor edits for clarity.
May 22, 2013 (Revision 2.00)	Schematic for three-wire operation added. Update for contact information, imagery for cover and headers.
April 5, 2011 (Revision 1.10)	Changed ZACwire™ description to OneWire; update for template. Updated contact information. Renamed ZMD31050 to ZSC31050.
April 8, 2010 (Revision 1.01)	Update for template.
September 21, 2009 (Revision 1.00)	First release.

Notice

1. Descriptions of circuits, software and other related information in this document are provided only to illustrate the operation of semiconductor products and application examples. You are fully responsible for the incorporation or any other use of the circuits, software, and information in the design of your product or system. Renesas Electronics disclaims any and all liability for any losses and damages incurred by you or third parties arising from the use of these circuits, software, or information.
2. Renesas Electronics hereby expressly disclaims any warranties against and liability for infringement or any other claims involving patents, copyrights, or other intellectual property rights of third parties, by or arising from the use of Renesas Electronics products or technical information described in this document, including but not limited to, the product data, drawings, charts, programs, algorithms, and application examples.
3. No license, express, implied or otherwise, is granted hereby under any patents, copyrights or other intellectual property rights of Renesas Electronics or others.
4. You shall be responsible for determining what licenses are required from any third parties, and obtaining such licenses for the lawful import, export, manufacture, sales, utilization, distribution or other disposal of any products incorporating Renesas Electronics products, if required.
5. You shall not alter, modify, copy, or reverse engineer any Renesas Electronics product, whether in whole or in part. Renesas Electronics disclaims any and all liability for any losses or damages incurred by you or third parties arising from such alteration, modification, copying or reverse engineering.
6. Renesas Electronics products are classified according to the following two quality grades: "Standard" and "High Quality". The intended applications for each Renesas Electronics product depends on the product's quality grade, as indicated below.
 - "Standard": Computers; office equipment; communications equipment; test and measurement equipment; audio and visual equipment; home electronic appliances; machine tools; personal electronic equipment; industrial robots; etc.
 - "High Quality": Transportation equipment (automobiles, trains, ships, etc.); traffic control (traffic lights); large-scale communication equipment; key financial terminal systems; safety control equipment; etc.
- Unless expressly designated as a high reliability product or a product for harsh environments in a Renesas Electronics data sheet or other Renesas Electronics document, Renesas Electronics products are not intended or authorized for use in products or systems that may pose a direct threat to human life or bodily injury (artificial life support devices or systems; surgical implantations; etc.), or may cause serious property damage (space system; undersea repeaters; nuclear power control systems; aircraft control systems; key plant systems; military equipment; etc.). Renesas Electronics disclaims any and all liability for any damages or losses incurred by you or any third parties arising from the use of any Renesas Electronics product that is inconsistent with any Renesas Electronics data sheet, user's manual or other Renesas Electronics document.
7. No semiconductor product is absolutely secure. Notwithstanding any security measures or features that may be implemented in Renesas Electronics hardware or software products, Renesas Electronics shall have absolutely no liability arising out of any vulnerability or security breach, including but not limited to any unauthorized access to or use of a Renesas Electronics product or a system that uses a Renesas Electronics product. RENESAS ELECTRONICS DOES NOT WARRANT OR GUARANTEE THAT RENESAS ELECTRONICS PRODUCTS, OR ANY SYSTEMS CREATED USING RENESAS ELECTRONICS PRODUCTS WILL BE INVULNERABLE OR FREE FROM CORRUPTION, ATTACK, VIRUSES, INTERFERENCE, HACKING, DATA LOSS OR THEFT, OR OTHER SECURITY INTRUSION ("Vulnerability Issues"). RENESAS ELECTRONICS DISCLAIMS ANY AND ALL RESPONSIBILITY OR LIABILITY ARISING FROM OR RELATED TO ANY VULNERABILITY ISSUES. FURTHERMORE, TO THE EXTENT PERMITTED BY APPLICABLE LAW, RENESAS ELECTRONICS DISCLAIMS ANY AND ALL WARRANTIES, EXPRESS OR IMPLIED, WITH RESPECT TO THIS DOCUMENT AND ANY RELATED OR ACCOMPANYING SOFTWARE OR HARDWARE, INCLUDING BUT NOT LIMITED TO THE IMPLIED WARRANTIES OF MERCHANTABILITY, OR FITNESS FOR A PARTICULAR PURPOSE.
8. When using Renesas Electronics products, refer to the latest product information (data sheets, user's manuals, application notes, "General Notes for Handling and Using Semiconductor Devices" in the reliability handbook, etc.), and ensure that usage conditions are within the ranges specified by Renesas Electronics with respect to maximum ratings, operating power supply voltage range, heat dissipation characteristics, installation, etc. Renesas Electronics disclaims any and all liability for any malfunctions, failure or accident arising out of the use of Renesas Electronics products outside of such specified ranges.
9. Although Renesas Electronics endeavors to improve the quality and reliability of Renesas Electronics products, semiconductor products have specific characteristics, such as the occurrence of failure at a certain rate and malfunctions under certain use conditions. Unless designated as a high reliability product or a product for harsh environments in a Renesas Electronics data sheet or other Renesas Electronics document, Renesas Electronics products are not subject to radiation resistance design. You are responsible for implementing safety measures to guard against the possibility of bodily injury, injury or damage caused by fire, and/or danger to the public in the event of a failure or malfunction of Renesas Electronics products, such as safety design for hardware and software, including but not limited to redundancy, fire control and malfunction prevention, appropriate treatment for aging degradation or any other appropriate measures. Because the evaluation of microcomputer software alone is very difficult and impractical, you are responsible for evaluating the safety of the final products or systems manufactured by you.
10. Please contact a Renesas Electronics sales office for details as to environmental matters such as the environmental compatibility of each Renesas Electronics product. You are responsible for carefully and sufficiently investigating applicable laws and regulations that regulate the inclusion or use of controlled substances, including without limitation, the EU RoHS Directive, and using Renesas Electronics products in compliance with all these applicable laws and regulations. Renesas Electronics disclaims any and all liability for damages or losses occurring as a result of your noncompliance with applicable laws and regulations.
11. Renesas Electronics products and technologies shall not be used for or incorporated into any products or systems whose manufacture, use, or sale is prohibited under any applicable domestic or foreign laws or regulations. You shall comply with any applicable export control laws and regulations promulgated and administered by the governments of any countries asserting jurisdiction over the parties or transactions.
12. It is the responsibility of the buyer or distributor of Renesas Electronics products, or any other party who distributes, disposes of, or otherwise sells or transfers the product to a third party, to notify such third party in advance of the contents and conditions set forth in this document.
13. This document shall not be reprinted, reproduced or duplicated in any form, in whole or in part, without prior written consent of Renesas Electronics.
14. Please contact a Renesas Electronics sales office if you have any questions regarding the information contained in this document or Renesas Electronics products.

(Note1) "Renesas Electronics" as used in this document means Renesas Electronics Corporation and also includes its directly or indirectly controlled subsidiaries.

(Note2) "Renesas Electronics product(s)" means any product developed or manufactured by or for Renesas Electronics.

(Disclaimer Rev.5.0-1)

Corporate Headquarters

TOYOSU FORESIA, 3-2-24 Toyosu,
Koto-ku, Tokyo 135-0061, Japan
www.renesas.com

Trademarks

Renesas and the Renesas logo are trademarks of Renesas Electronics Corporation. All trademarks and registered trademarks are the property of their respective owners.

Contact Information

For further information on a product, technology, the most up-to-date version of a document, or your nearest sales office, please visit:
www.renesas.com/contact/