

ZSSC3240 - Analog Front-End Configuration for External Temperature Sensor Acquisition

The configuration of the analog front end for interfacing an external temperature sensor (besides the main sensor element) requires the setting of parameters in relation to the specific topology and the type of transducer in consideration.

This document provides guidance for the application of typical combinations of main sensor and temperature sensor (with reference to T* and S* configurations as given in the data sheet), and the relevant configuration registers values.

Contents

1.	User Computer Requirements and Setup	3
1.1	Computer Requirements	3
1.2	Evaluation Software Installation and Setup	3
2.	HW Required Setup and System Start-Up	3
2.1	PCB-Boards.....	3
2.2	ZSSC3240 Evaluation Board Jumpers Setup	4
2.3	Complete Evaluation-Kit System.....	4
2.4	System Start-Up	5
3.	Main Sensor and External Temperature Combinations.....	5
3.1	T3.2 + S1: Register Settings	8
3.2	T4 + S1: Register Settings	9
3.3	T5 + S1: Register Settings	10
3.4	T1 + S2: Register Settings	11
3.5	T2 + S2: Register Settings	12
3.6	T3.1 + S3: Register Settings	13
4.	Design Constraints and Recommended Settings.....	14
5.	Configuration Data Input.....	14
6.	Glossary	14
	Revision History.....	14

List of Figures

Figure 1. EVB Jumper Settings	4
Figure 2. System Overview.....	4
Figure 3. GUI at Start-Up.....	5
Figure 4. T3.2 + S1 Equivalent Circuits	8
Figure 5. T4 + S1 Equivalent Circuits	9
Figure 6. T5 + S1 Equivalent Circuits	10
Figure 7. T1 + S2 Equivalent Circuits	11
Figure 8. T2 + S2 Equivalent Circuits	12
Figure 9. T3.1 + S3 Equivalent Circuits	13

List of Tables

Table 1. Configuration Combinations	6
---	---

1. User Computer Requirements and Setup

If the ZSSC3240 Evaluation Kit is used for the setup, a Windows®-based computer is required for interfacing with the device.

1.1 Computer Requirements

Note: The user must have administrative rights on the computer to download and install the ZSSC3240 Evaluation Software for the kit.

The user computer must meet the following requirements:

- Windows® 7, 8, 8.1, 10
- Microsoft® .NET Framework 4.0 or higher
- Supported architecture: x86 and x64
- USB port
- Internet access to download the install setup

1.2 Evaluation Software Installation and Setup

The latest version of ZSSC3240 Evaluation Software, which is required for the kit, must be downloaded from the Renesas web site at www.renesas.com/ZSSC3240KIT.

Note: FTDI USB drivers are needed only for backwards compatibility with older IDT/Renesas communication hardware. The software automatically installs the correct drivers after user confirmation if these drivers are not already installed on the user's computer.

Install the Evaluation Kit Software on the user's computer by the following steps:

1. Download and extract the contents of the ZSSC3240 Evaluation Software zip file to the user's computer.
2. Start installation by double clicking ZSSC324X_Evaluation_SW_v<x.xx>.exe file (the <x.xx> stands for the version number of the software).

All drivers and libraries are transferred within the executable file.

Note: starting the file could take some time due to unpacking all content. The process can be slowed down additionally by anti-virus software that may check each unpacked file.

2. HW Required Setup and System Start-Up

2.1 PCB-Boards

The following hardware boards are needed:

- ZSSC3240 Evaluation Board - ZSSC3240EVB
- SSC Communication board - SSCCOMMBOARDV4P1C

2.2 ZSSC3240 Evaluation Board Jumpers Setup

Remove all jumpers and ensure that J21, J22 (SPI side), J12 (5V side) are in place as per Figure 1.

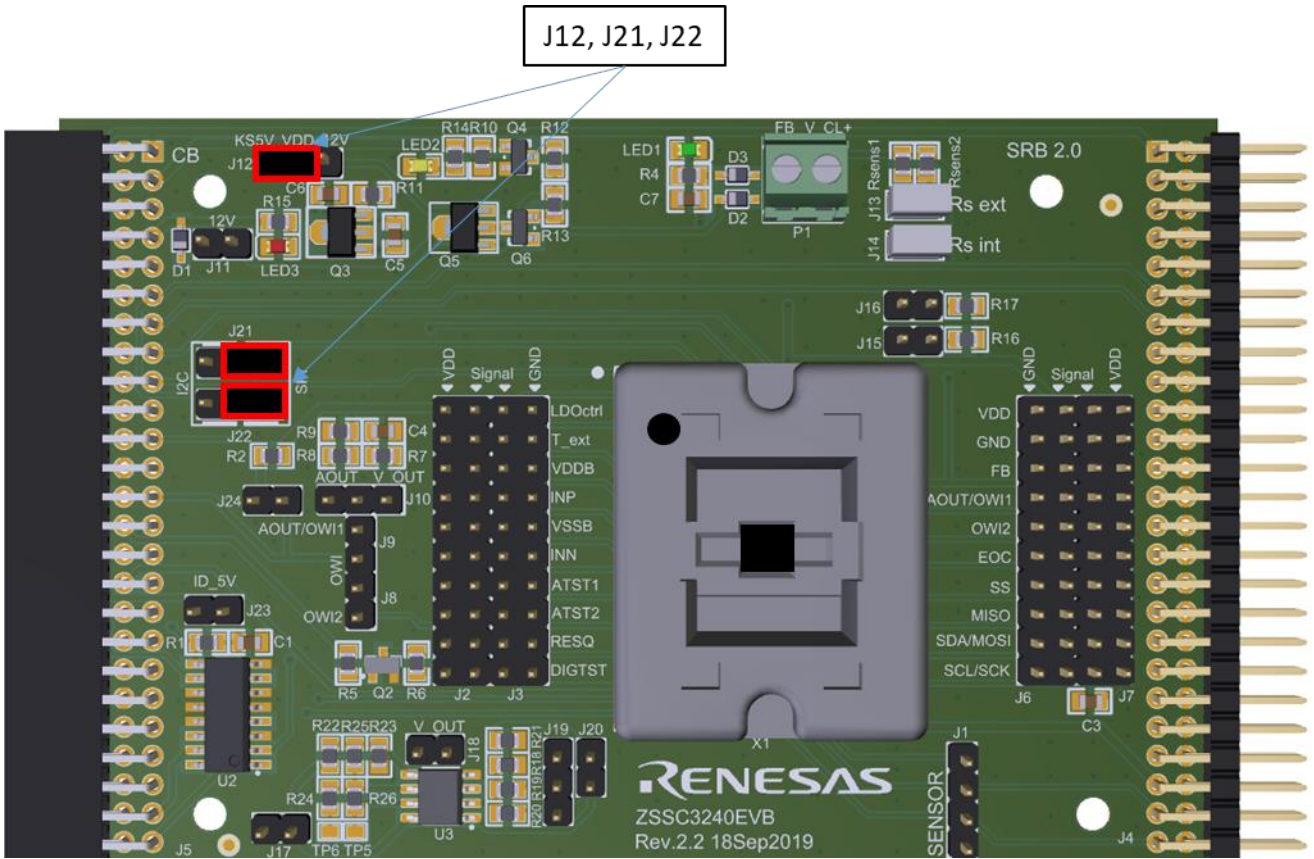

Figure 1. EVB Jumper Settings

2.3 Complete Evaluation-Kit System

See Figure 2 for system overview that is ready for operation.

The SPI communication bus is used between the Communication Board connected to the Host PC and the ZSSC3240EVB.

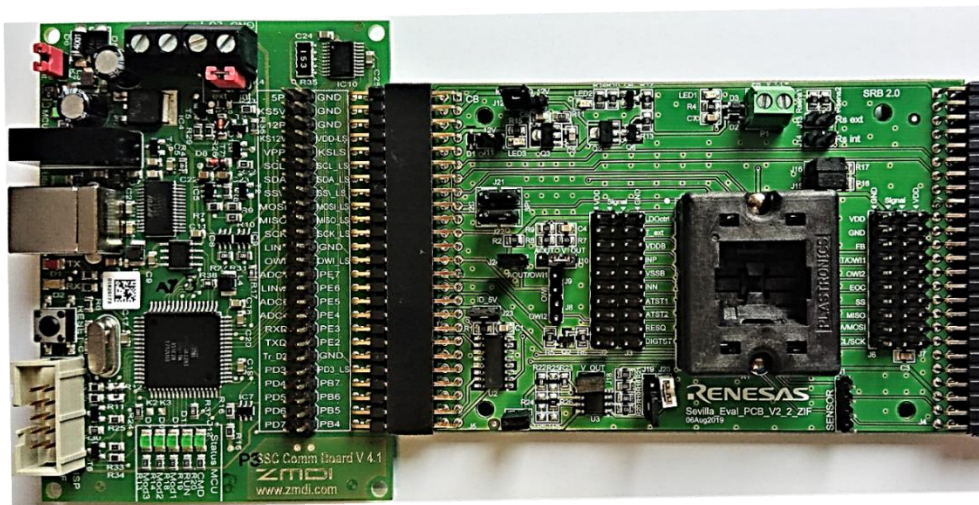

Figure 2. System Overview

2.4 System Start-Up

Open the EVK GUI interface; when the system is ready to operate the interface is as in Figure 3.

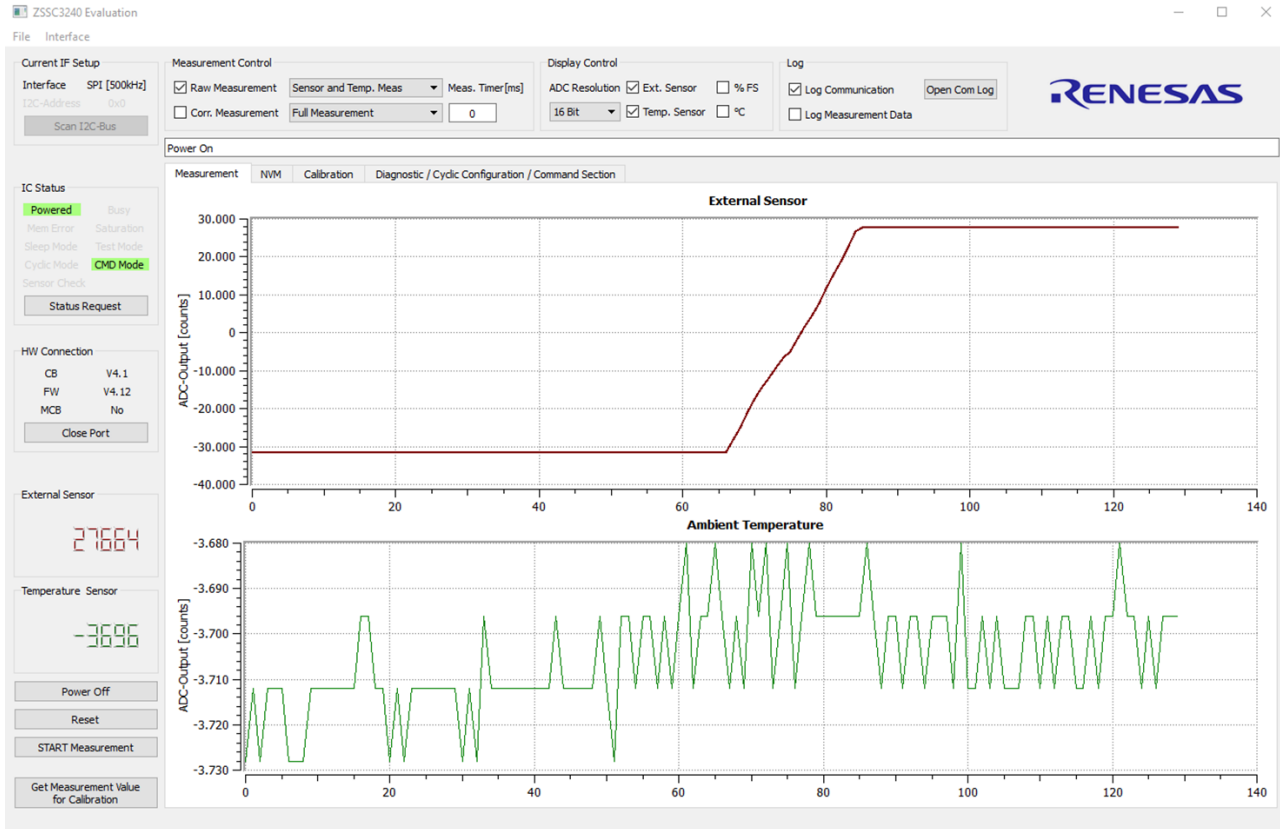

Figure 3. GUI at Start-Up

3. Main Sensor and External Temperature Combinations

It is possible to configure either the main sensor or the external temperature sensor, see *ZSSC3240 Datasheet* document for details. This application note considers the most common configurations and discusses the relevant register settings, see Table 1 for a summary of the combinations.

The following ZSSC3240 registers are involved in the configuration of the AFE for the discussed combinations:

- 0x03 - Smart Sensor Feature Configuration Register 1:
 - bit [12] - extra_rt
 - bit [11-9] - internal_rt
 - bit [8-7] - sensor_sup
 - bit [6-4] - temp_source
- 0x14 - Measurement Configuration Register 1:
 - bit [15] - sel_ref1
- 0x15 - Measurement Configuration Register 2:
 - bit [7:5] - Tbiasout

- 0x16 - External Temperature Measurement Configuration Register 1:
bit [15] - sel_ref2
- 0x17 - External Temperature Measurement Configuration Register 2:
bit [7:5] - Tbiasout

Table 1. Configuration Combinations

External temperature sensor connections are shown on the left images, main sensor connections on the right ones. Tracks in blue represent sensors supply lines, tracks in red indicate the signal inputs to the analog conditioning chain.

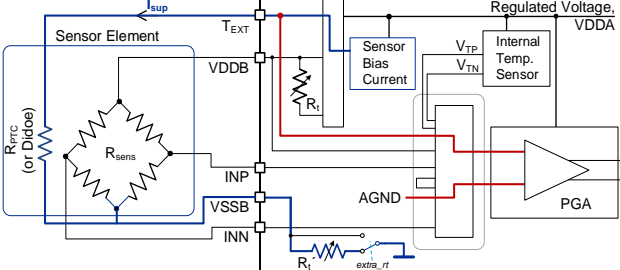
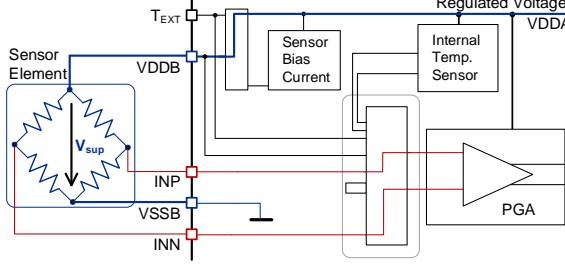
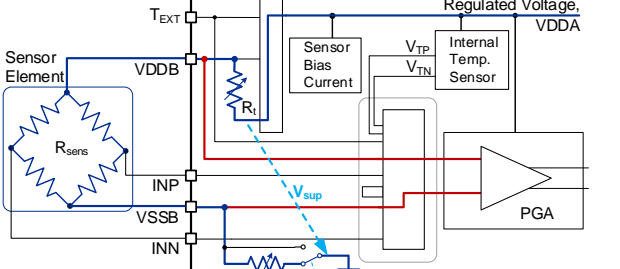
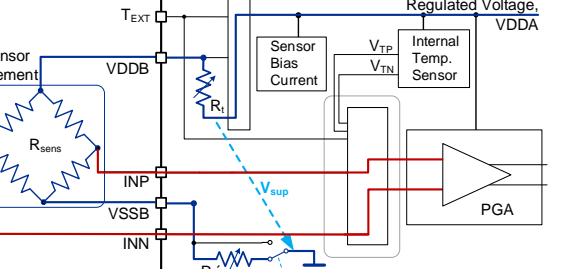
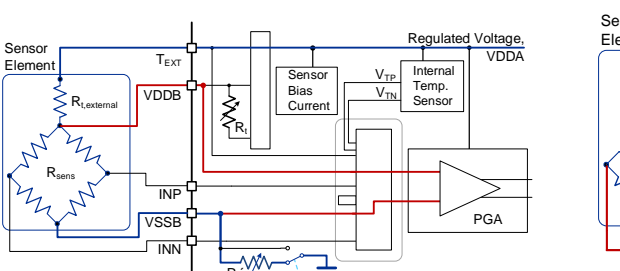
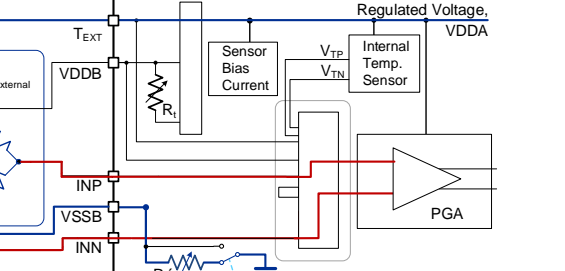
ID in Datasheet	Temperature Sensor Application + Main Sensor Application Supplies Type	Description
T3.2 + S1	Current + Voltage	Separate diode/PTC/NTC resistor as temperature sensor, supplied by a programmable current source with internal programmable R_t' . Main sensor element (bridge) supplied through a ratiometric voltage source.
		
T4 + S1	Voltage + Voltage	Bridge as temperature sensor with programmable internal R_t and R_t' , supplied by a ratiometric voltage source. Main sensor element (bridge), with programmable internal R_t and R_t' , supplied by a ratiometric voltage source.
		
T5 + S1	Voltage + Voltage	Bridge as temperature sensor with external R_t and internal programmable R_t' , supplied by a ratiometric voltage source. Main sensor element (bridge) with external R_t and internal programmable R_t' , supplied by a ratiometric voltage source.
		

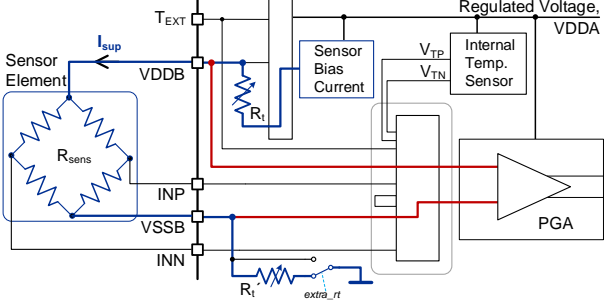
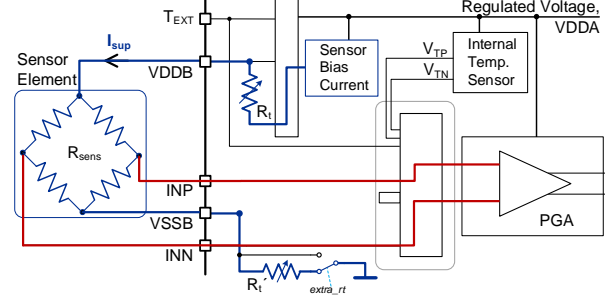
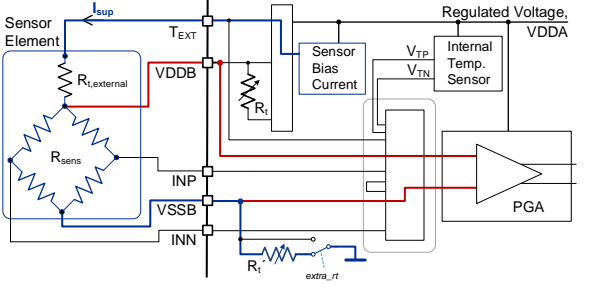
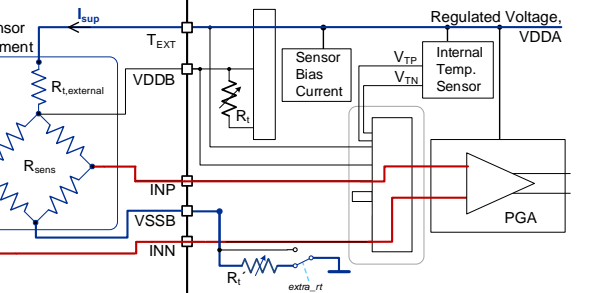
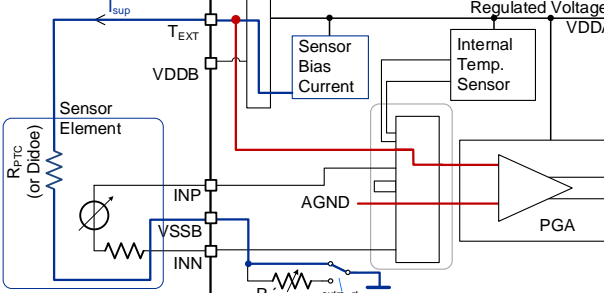
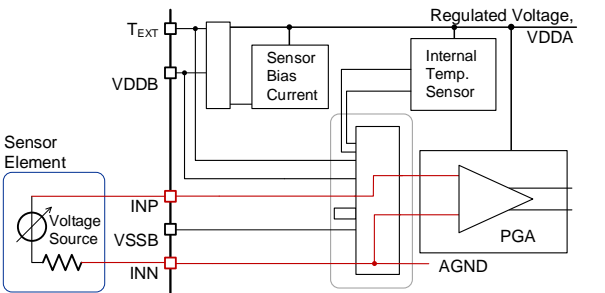
ID in Datasheet	Temperature Sensor Application + Main Sensor Application Supplies Type	Description
T1 + S2	Current + Current	Bridge as temperature sensor with an internal programmable R_t and R_t' , supplied by a programmable current source. Bridge as main sensor with an internal programmable R_t and R_t' , biased through a programmable current source.
		
T2 + S2	Current + Current	Bridge as temperature sensor with an external R_t and internal programmable R_t' , supplied by a programmable current source. Main sensor element (bridge) with an external R_t and internal programmable R_t' , biased through a programmable current source.
		
T3.1+ S3	Current + Voltage	Separate diode/PTC resistor as temperature sensor, supplied by a programmable current source. Absolute-voltage source as main sensor element.
		

Sections 3.1, 3.2, 3.3, 3.4, 3.5, and 3.6 detail the required register values and equivalent circuit diagrams for each combination highlighted in Table 1.

3.1 T3.2 + S1: Register Settings

Set the 0x03 - Smart Sensor Feature Configuration Register 1 as the following:

- bit [12] = 0_{BIN}
- bit [11-9] = XXX_{BIN} (dependent on the external components values and constraints listed in section 4)
- bit [8-7] = 01_{BIN}
- bit [6-4] = 100_{BIN}

Set the 0x14 - Measurement Configuration Register 1 as the following:

bit [15] = 1_{BIN}

Set the 0x15 - Measurement Configuration Register 2 as the following:

bit [7:5] = NA (any value)

Set the 0x16 - External Temperature Measurement Configuration Register 1 as the following:

bit [15] = 0_{BIN}

Set the 0x17 - External Temperature Measurement Configuration Register 2 as the following:

bit [7:5] = XXX_{BIN} (dependent on the external components values and constraints listed in section 4)

The PGA inputs are multiplexed between the equivalent circuits, see Figure 4.

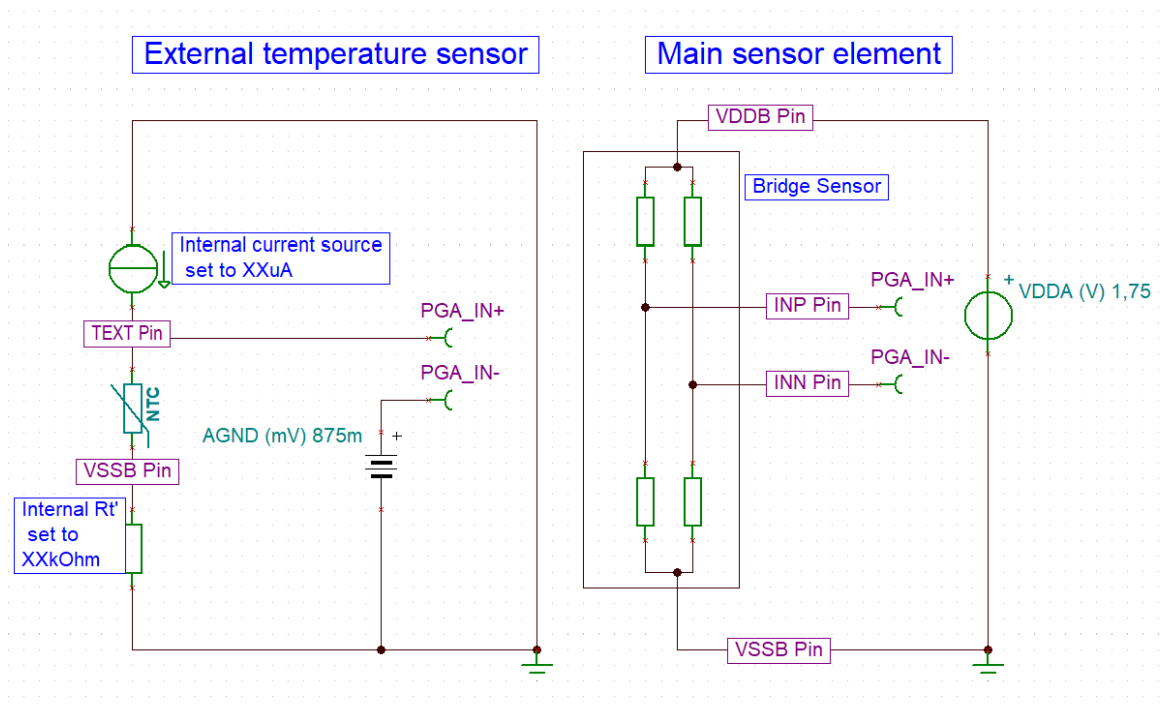

Figure 4. T3.2 + S1 Equivalent Circuits

3.2 T4 + S1: Register Settings

Set the 0x03 - Smart Sensor Feature Configuration Register 1 as the following:

- bit [12] = 0_{BIN}
- bit [11-9] = XXX_{BIN} (dependent on the external components values and constraints listed in section 4)
- bit [8-7] = 00_{BIN}
- bit [6-4] = 101_{BIN}

Set the 0x14 - Measurement Configuration Register 1 as the following:

bit [15] = 1_{BIN}

Set the 0x15 - Measurement Configuration Register 2 as the following:

bit [7:5] = NA (any value)

Set the 0x16 - External Temperature Measurement Configuration Register 1 as the following:

bit [15] = 1_{BIN}

Set the 0x17 - External Temperature Measurement Configuration Register 2 as the following:

bit [7:5] = NA (any value)

The PGA inputs are multiplexed between the equivalent circuits, see Figure 5.

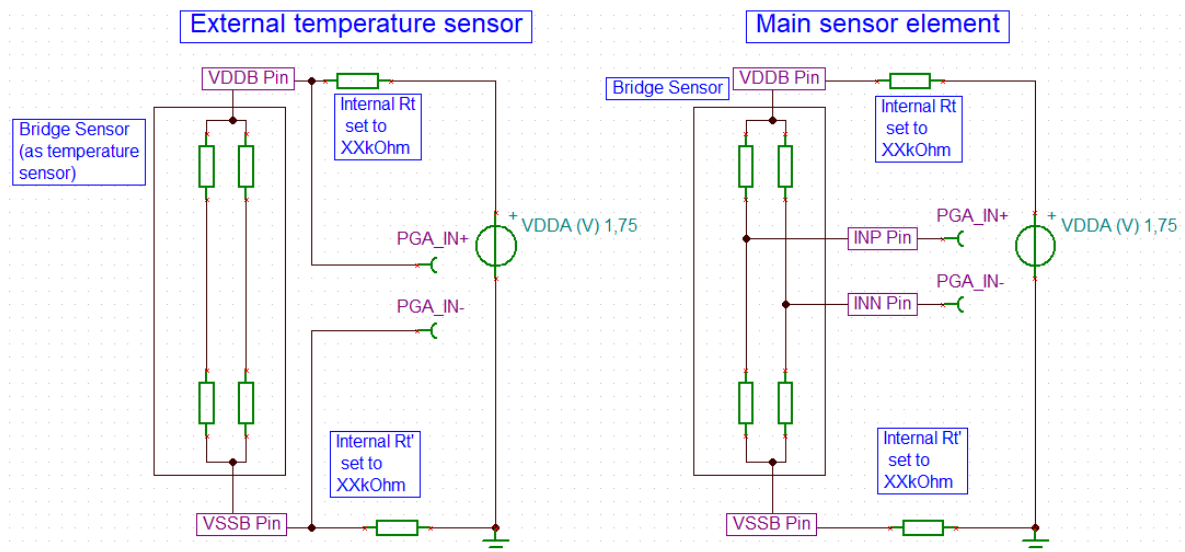

Figure 5. T4 + S1 Equivalent Circuits

3.3 T5 + S1: Register Settings

Set the 0x03 - Smart Sensor Feature Configuration Register 1 as the following:

- bit [12] = 0_{BIN}
- bit [11-9] = XXX_{BIN} (dependent on the external components values and constraints listed in section 4)
- bit [8-7] = 00_{BIN}
- bit [6-4] = 110_{BIN}

Set the 0x14 - Measurement Configuration Register 1 as the following:

bit [15] = 1_{BIN}

Set the 0x15 - Measurement Configuration Register 2 as the following:

bit [7:5] = NA (any value)

Set the 0x16 - External Temperature Measurement Configuration Register 1 as the following:

bit [15] = 1_{BIN}

Set the 0x17 - External Temperature Measurement Configuration Register 2 as the following:

bit [7:5] = NA (any value)

The PGA inputs are multiplexed between the equivalent circuits, see Figure 6.

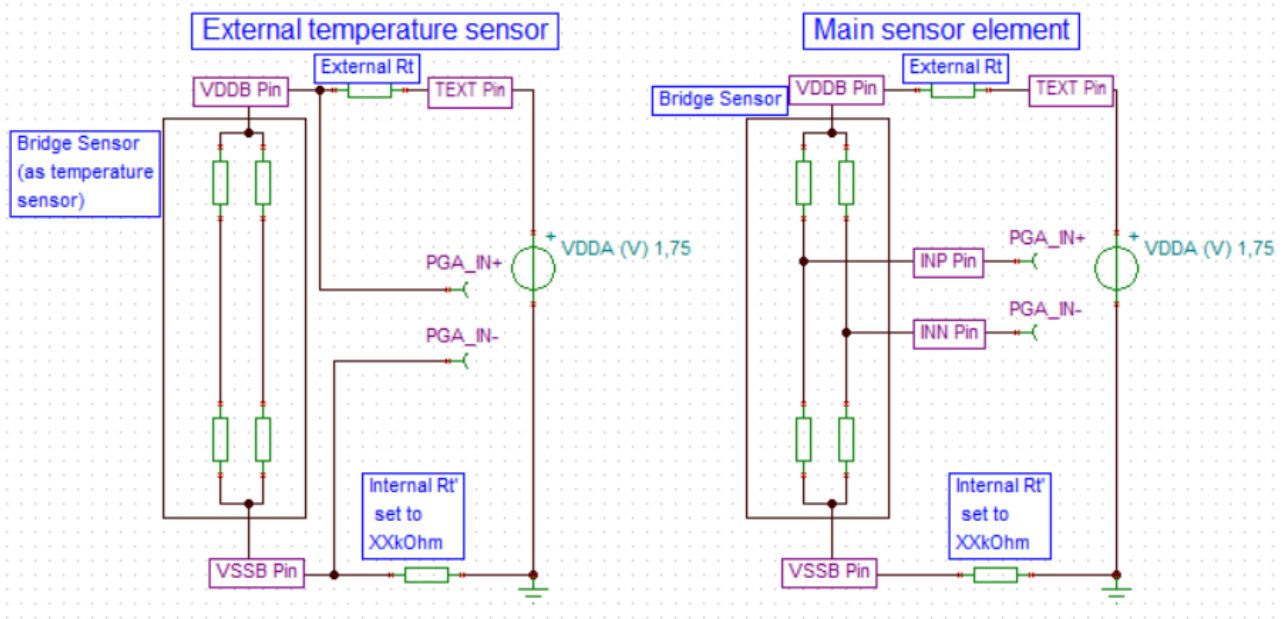

Figure 6. T5 + S1 Equivalent Circuits

3.4 T1 + S2: Register Settings

Set the 0x03 - Smart Sensor Feature Configuration Register 1 as the following:

- bit [12] = 0_{BIN}
- bit [11-9] = XXX_{BIN} (dependent on the external components values and constraints listed in section 4)
- bit [8-7] = 01_{BIN}
- bit [6-4] = 001_{BIN}

Set the 0x14 - Measurement Configuration Register 1 as the following:

bit [15] = 0_{BIN}

Set the 0x15 - Measurement Configuration Register 2 as the following:

bit [7:5] = XXX_{BIN} (dependent on the external components values and constraints listed in section 4)

Set the 0x16 - External Temperature Measurement Configuration Register 1 as the following:

bit [15] = 0_{BIN}

Set the 0x17 - External Temperature Measurement Configuration Register 2 as the following:

bit [7:5] = XXX_{BIN} (dependent on the external components values and constraints listed in section 4)

The PGA inputs are multiplexed between the equivalent circuits, see Figure 7.

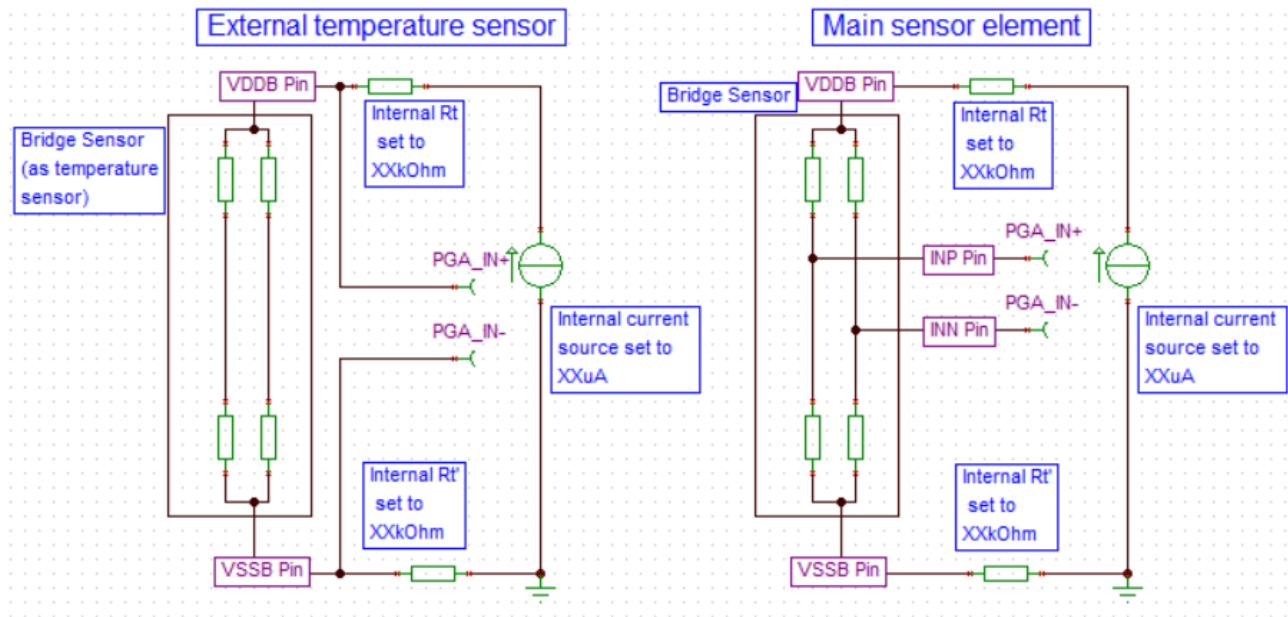

Figure 7. T1 + S2 Equivalent Circuits

3.5 T2 + S2: Register Settings

Set the 0x03 - Smart Sensor Feature Configuration Register 1 as the following:

- bit [12] = 0_{BIN}
- bit [11-9] = XXX_{BIN} (dependent on the external components values and constraints listed in section 4)
- bit [8-7] = 01_{BIN}
- bit [6-4] = 010_{BIN}

Set the 0x14 - Measurement Configuration Register 1 as the following:

bit [15] = 0_{BIN}

Set the 0x15 - Measurement Configuration Register 2 as the following:

bit [7:5] = XXX_{BIN} (dependent on the external components values and constraints listed in section 4)

Set the 0x16 - External Temperature Measurement Configuration Register 1 as the following:

bit [15] = 0_{BIN}

Set the 0x17 - External Temperature Measurement Configuration Register 2 as the following:

bit [7:5] = XXX_{BIN} (dependent on the external components values and constraints listed in section 4)

The PGA inputs are multiplexed between the equivalent circuits, see Figure 8.

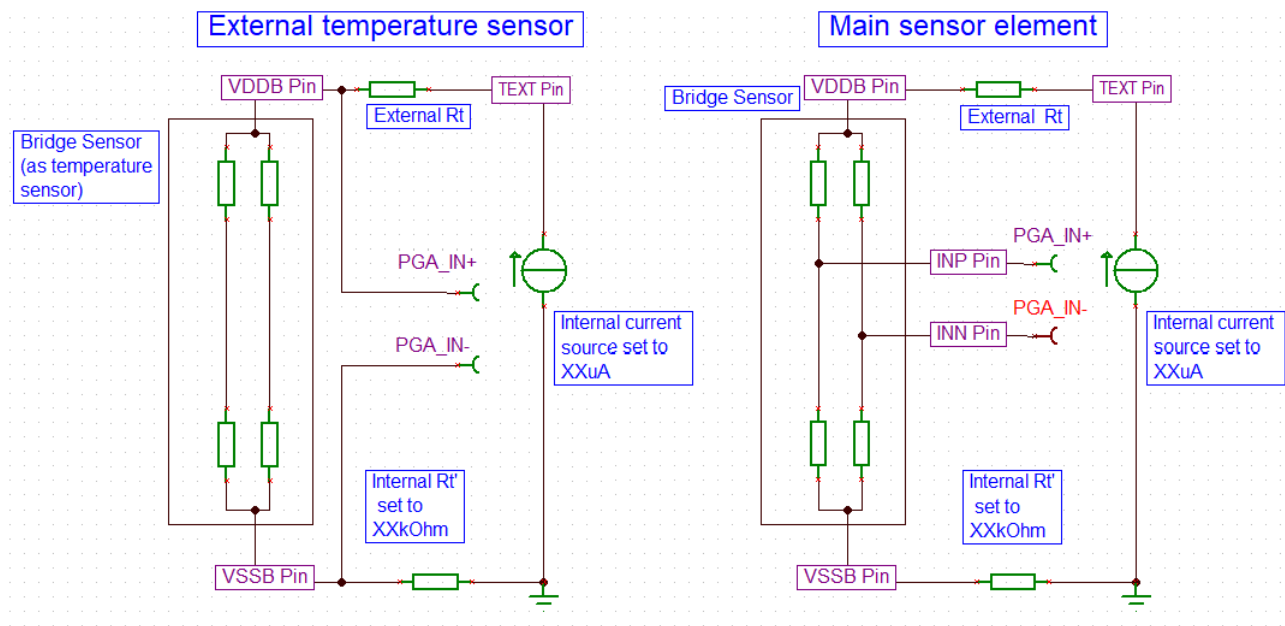

Figure 8. T2 + S2 Equivalent Circuits

3.6 T3.1 + S3: Register Settings

Set the 0x03 - Smart Sensor Feature Configuration Register 1 as the following:

- bit [12] = 0_{BIN}
- bit [11-9] = NA (any value)
- bit [8-7] = 10_{BIN}
- bit [6-4] = 100_{BIN}

Set the 0x14 - Measurement Configuration Register 1 as the following:

bit [15] = 0_{BIN}

Set the 0x15 - Measurement Configuration Register 2 as the following:

bit [7:5] = NA (any value)

Set the 0x16 - External Temperature Measurement Configuration Register 1 as the following:

bit [15] = 0_{BIN}

Set the 0x17 - External Temperature Measurement Configuration Register 2 as the following:

bit [7:5] = XXX_{BIN} (dependent on the external components values and constraints listed in section 4)

The PGA inputs are multiplexed between the equivalent circuits, see Figure 9.

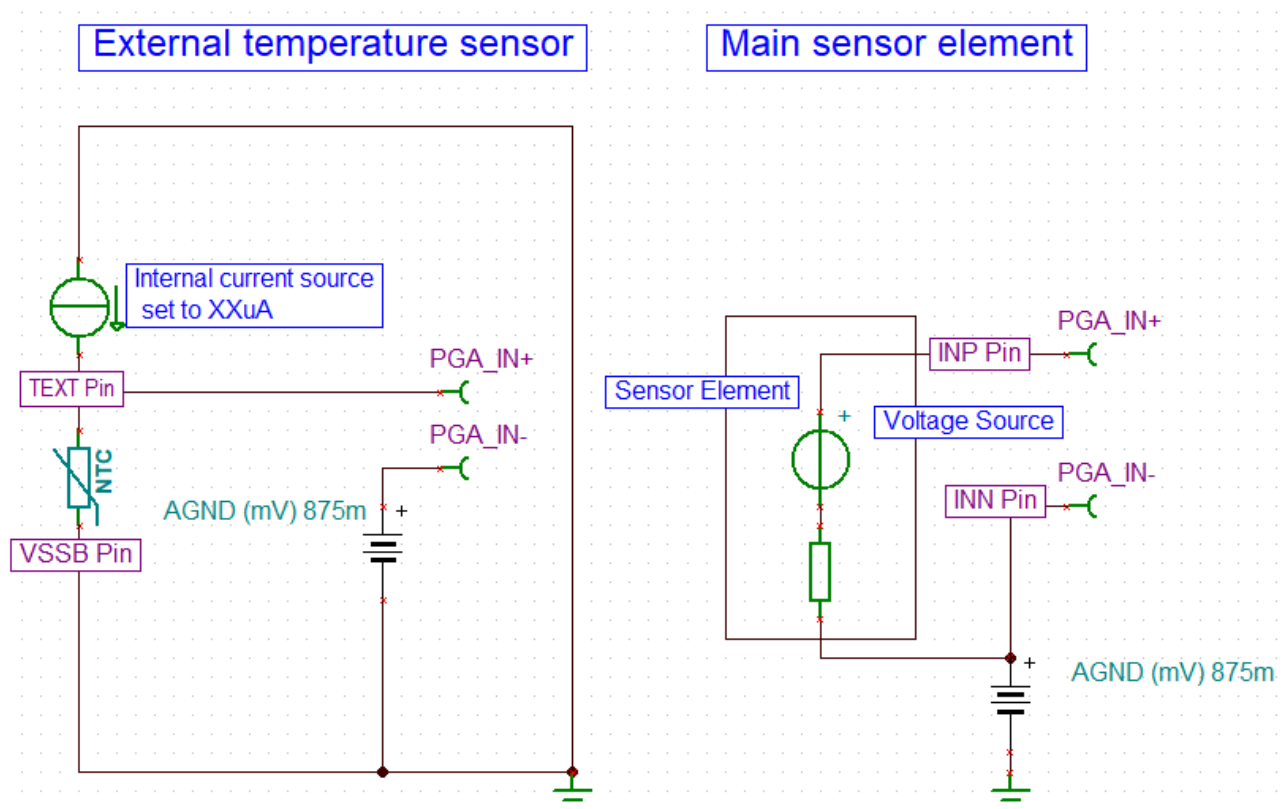

Figure 9. T3.1 + S3 Equivalent Circuits

4. Design Constraints and Recommended Settings

Ensure that the following constraints are met (see *ZSSC3240 Datasheet* document for numerical references):

1. Voltage at pins INP/INN are within the absolute sensor input range and the differential input signal range.
2. Voltage at pin T_{EXT} is within external temperature diode or RTD input range.
3. R_{sensor} is within the external sensor (bridge) resistance range.
4. The internal top/bottom programmable resistance Rt and Rt' are set to drop the resulting voltage on the resistive elements to values compatible with the configuration of step 1 and 2.
5. The internal programmable current sources level is set correctly to drop the resulting voltage on the internal and internal resistive elements to values compatible with the configuration of step 1 and 2.

5. Configuration Data Input

It is recommended to use the memory map to input the Smart Sensor Feature Configuration Register 1 (0x03) values in the device memory after the desired configuration is defined. This helps to avoid unintended settings that may occur if using the list of values available in the GUI for the mentioned configuration register.

A write to NVM and a device reset are required to enable the new settings after the AFE configuration is completed.

6. Glossary

Term	Description
AFE	Analog Front-End
FS	Full Scale
GUI	Graphical User Interface
IC	Integrated Circuit
NVM	Non Volatile Memory
PC	Personal Computer
SSC	Sensor Signal Conditioner

Revision History

Rev.	Date	Description	
		Page	Summary
1.0	Nov.30.20		Initial release.
1.1	Jun.02.21	8	Corrected settings for T3.2+S1

Notice

1. Descriptions of circuits, software and other related information in this document are provided only to illustrate the operation of semiconductor products and application examples. You are fully responsible for the incorporation or any other use of the circuits, software, and information in the design of your product or system. Renesas Electronics disclaims any and all liability for any losses and damages incurred by you or third parties arising from the use of these circuits, software, or information.
2. Renesas Electronics hereby expressly disclaims any warranties against and liability for infringement or any other claims involving patents, copyrights, or other intellectual property rights of third parties, by or arising from the use of Renesas Electronics products or technical information described in this document, including but not limited to, the product data, drawings, charts, programs, algorithms, and application examples.
3. No license, express, implied or otherwise, is granted hereby under any patents, copyrights or other intellectual property rights of Renesas Electronics or others.
4. You shall be responsible for determining what licenses are required from any third parties, and obtaining such licenses for the lawful import, export, manufacture, sales, utilization, distribution or other disposal of any products incorporating Renesas Electronics products, if required.
5. You shall not alter, modify, copy, or reverse engineer any Renesas Electronics product, whether in whole or in part. Renesas Electronics disclaims any and all liability for any losses or damages incurred by you or third parties arising from such alteration, modification, copying or reverse engineering.
6. Renesas Electronics products are classified according to the following two quality grades: "Standard" and "High Quality". The intended applications for each Renesas Electronics product depends on the product's quality grade, as indicated below.
 - "Standard": Computers; office equipment; communications equipment; test and measurement equipment; audio and visual equipment; home electronic appliances; machine tools; personal electronic equipment; industrial robots; etc.
 - "High Quality": Transportation equipment (automobiles, trains, ships, etc.); traffic control (traffic lights); large-scale communication equipment; key financial terminal systems; safety control equipment; etc.
- Unless expressly designated as a high reliability product or a product for harsh environments in a Renesas Electronics data sheet or other Renesas Electronics document, Renesas Electronics products are not intended or authorized for use in products or systems that may pose a direct threat to human life or bodily injury (artificial life support devices or systems; surgical implantations; etc.), or may cause serious property damage (space system; undersea repeaters; nuclear power control systems; aircraft control systems; key plant systems; military equipment; etc.). Renesas Electronics disclaims any and all liability for any damages or losses incurred by you or any third parties arising from the use of any Renesas Electronics product that is inconsistent with any Renesas Electronics data sheet, user's manual or other Renesas Electronics document.
7. No semiconductor product is absolutely secure. Notwithstanding any security measures or features that may be implemented in Renesas Electronics hardware or software products, Renesas Electronics shall have absolutely no liability arising out of any vulnerability or security breach, including but not limited to any unauthorized access to or use of a Renesas Electronics product or a system that uses a Renesas Electronics product. RENESAS ELECTRONICS DOES NOT WARRANT OR GUARANTEE THAT RENESAS ELECTRONICS PRODUCTS, OR ANY SYSTEMS CREATED USING RENESAS ELECTRONICS PRODUCTS WILL BE INVULNERABLE OR FREE FROM CORRUPTION, ATTACK, VIRUSES, INTERFERENCE, HACKING, DATA LOSS OR THEFT, OR OTHER SECURITY INTRUSION ("Vulnerability Issues"). RENESAS ELECTRONICS DISCLAIMS ANY AND ALL RESPONSIBILITY OR LIABILITY ARISING FROM OR RELATED TO ANY VULNERABILITY ISSUES. FURTHERMORE, TO THE EXTENT PERMITTED BY APPLICABLE LAW, RENESAS ELECTRONICS DISCLAIMS ANY AND ALL WARRANTIES, EXPRESS OR IMPLIED, WITH RESPECT TO THIS DOCUMENT AND ANY RELATED OR ACCOMPANYING SOFTWARE OR HARDWARE, INCLUDING BUT NOT LIMITED TO THE IMPLIED WARRANTIES OF MERCHANTABILITY, OR FITNESS FOR A PARTICULAR PURPOSE.
8. When using Renesas Electronics products, refer to the latest product information (data sheets, user's manuals, application notes, "General Notes for Handling and Using Semiconductor Devices" in the reliability handbook, etc.), and ensure that usage conditions are within the ranges specified by Renesas Electronics with respect to maximum ratings, operating power supply voltage range, heat dissipation characteristics, installation, etc. Renesas Electronics disclaims any and all liability for any malfunctions, failure or accident arising out of the use of Renesas Electronics products outside of such specified ranges.
9. Although Renesas Electronics endeavors to improve the quality and reliability of Renesas Electronics products, semiconductor products have specific characteristics, such as the occurrence of failure at a certain rate and malfunctions under certain use conditions. Unless designated as a high reliability product or a product for harsh environments in a Renesas Electronics data sheet or other Renesas Electronics document, Renesas Electronics products are not subject to radiation resistance design. You are responsible for implementing safety measures to guard against the possibility of bodily injury, injury or damage caused by fire, and/or danger to the public in the event of a failure or malfunction of Renesas Electronics products, such as safety design for hardware and software, including but not limited to redundancy, fire control and malfunction prevention, appropriate treatment for aging degradation or any other appropriate measures. Because the evaluation of microcomputer software alone is very difficult and impractical, you are responsible for evaluating the safety of the final products or systems manufactured by you.
10. Please contact a Renesas Electronics sales office for details as to environmental matters such as the environmental compatibility of each Renesas Electronics product. You are responsible for carefully and sufficiently investigating applicable laws and regulations that regulate the inclusion or use of controlled substances, including without limitation, the EU RoHS Directive, and using Renesas Electronics products in compliance with all these applicable laws and regulations. Renesas Electronics disclaims any and all liability for damages or losses occurring as a result of your noncompliance with applicable laws and regulations.
11. Renesas Electronics products and technologies shall not be used for or incorporated into any products or systems whose manufacture, use, or sale is prohibited under any applicable domestic or foreign laws or regulations. You shall comply with any applicable export control laws and regulations promulgated and administered by the governments of any countries asserting jurisdiction over the parties or transactions.
12. It is the responsibility of the buyer or distributor of Renesas Electronics products, or any other party who distributes, disposes of, or otherwise sells or transfers the product to a third party, to notify such third party in advance of the contents and conditions set forth in this document.
13. This document shall not be reprinted, reproduced or duplicated in any form, in whole or in part, without prior written consent of Renesas Electronics.
14. Please contact a Renesas Electronics sales office if you have any questions regarding the information contained in this document or Renesas Electronics products.

(Note1) "Renesas Electronics" as used in this document means Renesas Electronics Corporation and also includes its directly or indirectly controlled subsidiaries.

(Note2) "Renesas Electronics product(s)" means any product developed or manufactured by or for Renesas Electronics.

(Disclaimer Rev.5.0-1)

Corporate Headquarters

TOYOSU FORESIA, 3-2-24 Toyosu,
Koto-ku, Tokyo 135-0061, Japan
www.renesas.com

Trademarks

Renesas and the Renesas logo are trademarks of Renesas Electronics Corporation. All trademarks and registered trademarks are the property of their respective owners.

Contact Information

For further information on a product, technology, the most up-to-date version of a document, or your nearest sales office, please visit:
www.renesas.com/contact/