

Description

The ICS664-03 provides clock generation and conversion for clock rates commonly needed in HDTV digital video equipment. The ICS664-03 uses the latest PLL technology to provide excellent phase noise and long term jitter performance for superior synchronization and S/N ratio.

The ICS664-03 is suitable for Digital Video STB and DTV applications. For Transmitter application use ICS664-01 or ICS664-02.

For audio sampling clocks generated from 27 MHz, use the ICS661.

Please contact IDT if you have a requirement for an input and output frequency not included in this document. IDT can rapidly modify this product to meet special requirements.

Features

- Packaged in 16-pin TSSOP
- Pb (lead) free package, RoHS compliant
- Clock or crystal input provides flexibility
- Low phase noise supports enhanced SNR
- Lowest jitter in class at 100 ps
- Exact (0 ppm) multiplication ratios
- Power-down mode lowers power consumption
- Improved phase noise over ICS660
- Provides High definition Video clocks for 720p, 1080i and 1080p YUV standards

Block Diagram

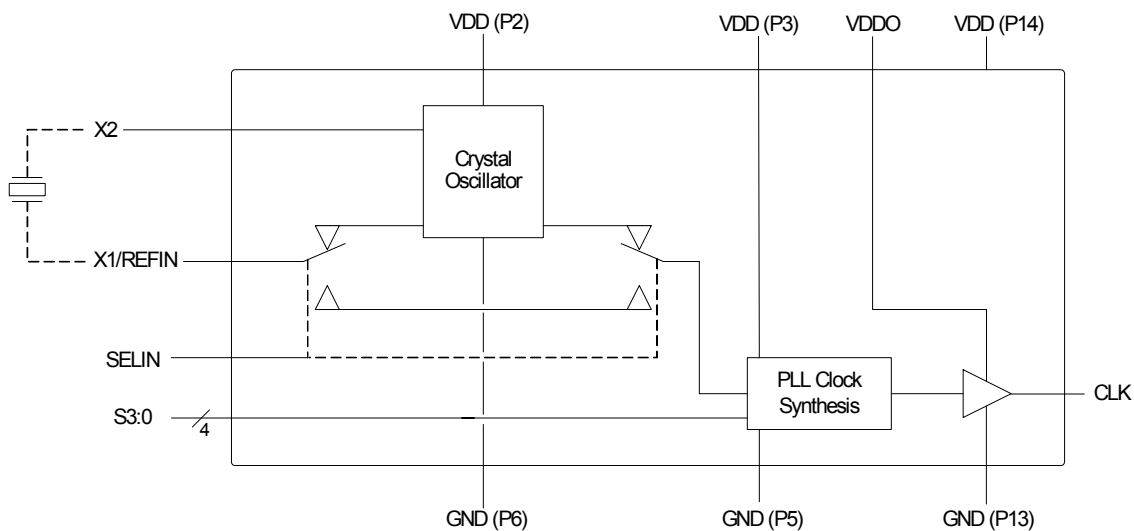

Pin Assignment

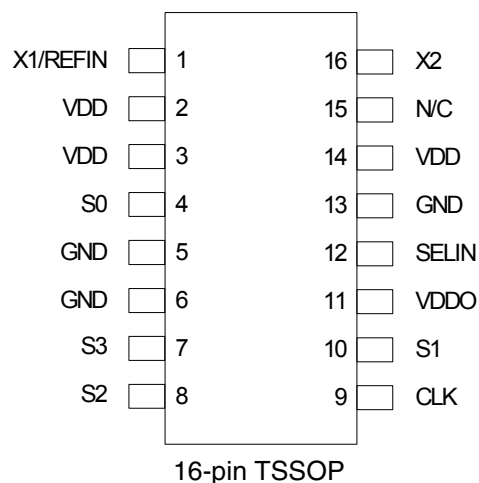

Output Clock Selection Table

S3	S2	S1	S0	Input Frequency (MHz)	Output Frequency (MHz)
0	0	0	0		Power down
0	0	0	1	27	27 (passthrough)
0	0	1	0	27	74.25
0	0	1	1	27	74.175824
0	1	0	0	13.5	74.25
0	1	0	1	13.5	74.175824
0	1	1	0	27	148.5000
0	1	1	1	27	148.351648
1	0	0	0	74.25	54
1	0	0	1	74.175824	54
1	0	1	0	74.25	27
1	0	1	1	74.175824	27
1	1	0	0	54	74.25
1	1	0	1	54	74.175824
1	1	1	0	54	13.5
1	1	1	1	27	13.5

Pin Descriptions

Pin Number	Pin Name	Pin Type	Pin Description
1	X1/REFIN	Input	Connect this pin to a crystal or clock input
2	VDD	Power	Power supply for crystal oscillator.
3	VDD	Power	Power supply for PLL.
4	S0	Input	Output frequency selection. Determines output frequency per table above. Internal pull-up.
5	GND	Power	Ground for PLL.
6	GND	Power	Ground for PLL for Crystal Oscillator.
7	S3	Input	Output frequency selection. Determines output frequency per table above. Internal pull-up.
8	S2	Input	Output frequency selection. Determines output frequency per table above. Internal pull-up.
9	CLK	Output	Clock output.
10	S1	Input	Output frequency selection. Determines output frequency per table above. Internal pull-up.
11	VDDO	Power	Power supply for output stage.
12	SEL	Input	Low for clock input, high for crystal. Internal pull-up.
13	GND	Power	Ground for Output.
14	VDD	Power	Power supply.
15	NC	—	No connect. Do not connect to anything.
16	X2	Input	Connect this pin to a crystal. Leave open if using a clock input.

Application Information

Series Termination Resistor

Clock output traces should use series termination. To series terminate a 50Ω trace (a commonly used trace impedance), place a 33Ω resistor in series with the clock line, as close to the clock output pin as possible. The nominal impedance of the clock output is 20Ω.

Decoupling Capacitors

As with any high-performance mixed-signal IC, the ICS664-03 must be isolated from system power supply noise to perform optimally.

Decoupling capacitors of 0.01μF must be connected between each VDD and the PCB ground plane. To further guard against interfering system supply noise, the ICS664-03 should use one common connection to the PCB power plane as shown in the diagram on the next page. The ferrite bead and bulk capacitor help reduce lower frequency noise in the supply that can lead to output clock phase modulation.

Recommended Power Supply Connection for Optimal Device Performance

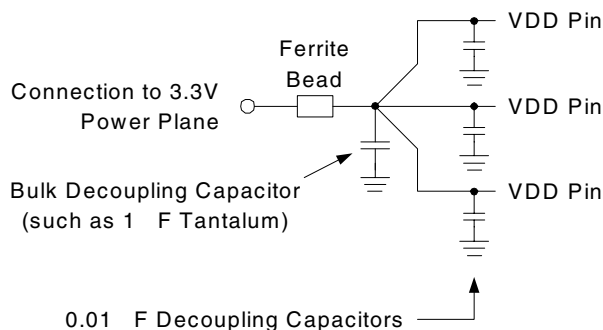

All power supply pins must be connected to the same voltage, except VDDO, which may be connected to a lower voltage in order to change the output level.

To achieve the absolute minimum jitter, power the part with a dedicated LDO regulator, which will provide high isolation from power supply noise. Many companies produce very small, inexpensive regulators; an example is the National Semiconductor LP2985.

Crystal Load Capacitors

If a crystal is used, the device crystal connections should include pads for capacitors from X1 to ground and from X2 to ground. These capacitors are used to adjust the stray capacitance of the board to match the nominally required crystal load capacitance. To reduce possible noise pickup, use very short PCB traces (and no vias) between the crystal and device.

The value of the load capacitors can be roughly determined by the formula $C = 2(C_L - 6)$ where C is the load capacitor connected to X1 and X2, and C_L is the specified value of the load capacitance for the crystal. A typical crystal C_L is 18 pF, so $C = 2(18 - 6) = 24$ pF. Because these capacitors adjust the stray capacitance of the PCB, check the output frequency using your final layout to see if the value of C should be changed.

PCB Layout Recommendations

For optimum device performance and lowest output phase noise, the following guidelines should be observed.

- 1) Each 0.01μF decoupling capacitor should be mounted on the component side of the board as close to the VDD pin as possible. No vias should be used between decoupling capacitor and VDD pin. The PCB trace to VDD pin should be kept as short as possible, as should the PCB trace to the ground via. Distance of the ferrite bead and bulk decoupling from the device is less critical.
- 2) The external crystal should be mounted next to the device with short traces. The X1 and X2 traces should not be routed next to each other with minimum spaces, instead they should be separated and away from other traces.
- 3) To minimize EMI and obtain the best signal integrity, the 33Ω series termination resistor should be placed close to the clock output.
- 4) An optimum layout is one with all components on the same side of the board, minimizing vias through other signal layers (the ferrite bead and bulk decoupling capacitor can be mounted on the back). Other signal traces should be routed away from the ICS664-03. This includes signal traces just underneath the device, or on layers adjacent to the ground plane layer used by the device.

Absolute Maximum Ratings

Stresses above the ratings listed below can cause permanent damage to the ICS664-03. These ratings, which are standard values for IDT commercially rated parts, are stress ratings only. Functional operation of the device at these or any other conditions above those indicated in the operational sections of the specifications is not implied. Exposure to absolute maximum rating conditions for extended periods can affect product reliability. Electrical parameters are guaranteed only over the recommended operating temperature range.

Item	Rating
Supply Voltage, VDD	5.5 V
All Inputs and Outputs	-0.5 V to VDD+0.5 V
Ambient Operating Temperature	0 to +70° C
Storage Temperature	-65 to +150° C
Junction Temperature	125° C
Soldering Temperature	260° C

Recommended Operation Conditions

Parameter	Min.	Typ.	Max.	Units
Ambient Operating Temperature	0		+70	°C
Power Supply Voltage (measured in respect to GND)	+3.0		+3.6	V

DC Electrical Characteristics

Unless stated otherwise, VDD = 3.3 V ±10%, Ambient Temperature 0 to +70° C

Parameter	Symbol	Conditions	Min.	Typ.	Max.	Units
Operating Voltage	VDD		3.0		3.6	V
	VDDO		2.5		VDD	V
Supply Current	IDD	No Load		35		mA
Input High Voltage	V _{IH}		2			V
Input Low Voltage	V _{IL}				0.8	V
Output High Voltage	V _{OH}	I _{OH} = -4 mA	VDD-0.4			V
Output High Voltage	V _{OH}	I _{OH} = -20 mA	2.4			V
Output Low Voltage	V _{OL}	I _{OL} = 20 mA			0.4	V
Short Circuit Current	I _{OS}	Each output		±65		mA
Nominal Output Impedance	Z _{OUT}			20		Ω
Input Capacitance	C _{IN}	Input pins		7		pF
Internal Pull-up Resistor	R _{PU}			120		kΩ

AC Electrical Characteristics

Unless stated otherwise, $V_{DD} = 3.3\text{ V} \pm 10\%$, Ambient Temperature 0 to $+70^{\circ}\text{C}$

Parameter	Symbol	Conditions	Min.	Typ.	Max.	Units
Crystal Frequency					28	MHz
Output Clock Rise Time	t_{OR}	20% to 80%, 15 pF load			1.5	ns
Output Clock Fall Time	t_{OF}	80% to 20%, 15 pF load			1.5	ns
Output Duty Cycle	t_{OD}	at $V_{DD}/2$, 15 pF load	40	49 to 51	60	%
Power-up Time	t_{PU}	Valid power on to valid output		1		ms
Power-down Time	t_{PD}	Power off to clock disable		10		μs
Jitter, short term				100		ps p-p
Jitter, long term		10 μs delay		200		ps p-p
Single Sideband Phase Noise		10 kHz offset		-120		dBc
Actual Mean Frequency Error versus Target				0		ppm

Thermal Characteristics

Parameter	Symbol	Conditions	Min.	Typ.	Max.	Units
Thermal Resistance Junction to Ambient	θ_{JA}	Still air		78		$^{\circ}\text{C/W}$
	θ_{JA}	1 m/s air flow		70		$^{\circ}\text{C/W}$
	θ_{JA}	3 m/s air flow		68		$^{\circ}\text{C/W}$
Thermal Resistance Junction to Case	θ_{JC}			37		$^{\circ}\text{C/W}$

Package Outline and Package Dimensions (16-pin TSSOP, 4.40 mm Body, 0.65 mm Pitch)

Package dimensions are kept current with JEDEC Publication No. 95, MO-153

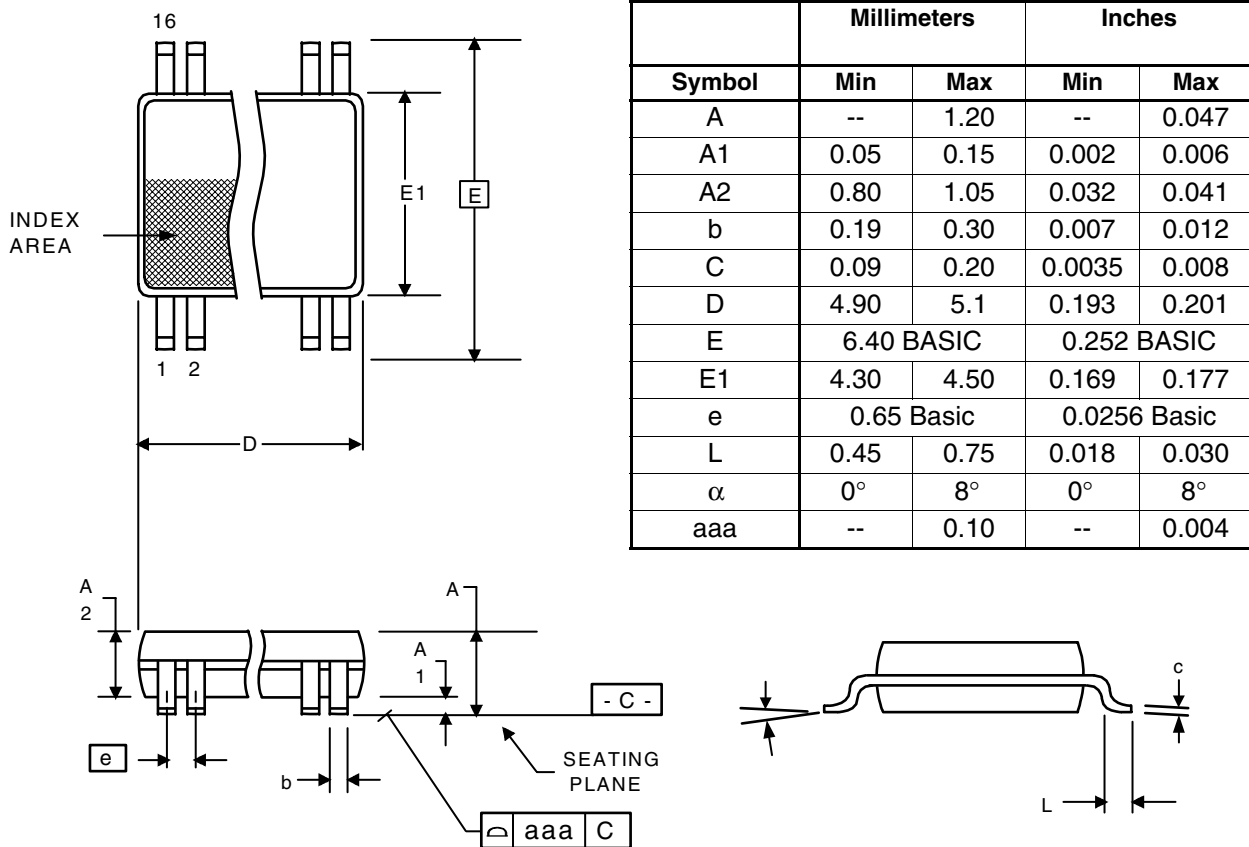

Ordering Information

Part / Order Number	Marking	Shipping Packaging	Package	Temperature
664G-03LF	664G03LF	Tubes	16-pin TSSOP	0 to +70° C
664G-03LFT	664G03LF	Tape and Reel	16-pin TSSOP	0 to +70° C

“LF” denotes Pb (lead) free package.

While the information presented herein has been checked for both accuracy and reliability, Integrated Device Technology (IDT) assumes no responsibility for either its use or for the infringement of any patents or other rights of third parties, which would result from its use. No other circuits, patents, or licenses are implied. This product is intended for use in normal commercial applications. Any other applications such as those requiring extended temperature range, high reliability, or other extraordinary environmental requirements are not recommended without additional processing by IDT. IDT reserves the right to change any circuitry or specifications without notice. IDT does not authorize or warrant any IDT product for use in life support devices or critical medical instruments.

IMPORTANT NOTICE AND DISCLAIMER

RENESAS ELECTRONICS CORPORATION AND ITS SUBSIDIARIES (“RENESAS”) PROVIDES TECHNICAL SPECIFICATIONS AND RELIABILITY DATA (INCLUDING DATASHEETS), DESIGN RESOURCES (INCLUDING REFERENCE DESIGNS), APPLICATION OR OTHER DESIGN ADVICE, WEB TOOLS, SAFETY INFORMATION, AND OTHER RESOURCES “AS IS” AND WITH ALL FAULTS, AND DISCLAIMS ALL WARRANTIES, EXPRESS OR IMPLIED, INCLUDING, WITHOUT LIMITATION, ANY IMPLIED WARRANTIES OF MERCHANTABILITY, FITNESS FOR A PARTICULAR PURPOSE, OR NON-INFRINGEMENT OF THIRD-PARTY INTELLECTUAL PROPERTY RIGHTS.

These resources are intended for developers who are designing with Renesas products. You are solely responsible for (1) selecting the appropriate products for your application, (2) designing, validating, and testing your application, and (3) ensuring your application meets applicable standards, and any other safety, security, or other requirements. These resources are subject to change without notice. Renesas grants you permission to use these resources only to develop an application that uses Renesas products. Other reproduction or use of these resources is strictly prohibited. No license is granted to any other Renesas intellectual property or to any third-party intellectual property. Renesas disclaims responsibility for, and you will fully indemnify Renesas and its representatives against, any claims, damages, costs, losses, or liabilities arising from your use of these resources. Renesas' products are provided only subject to Renesas' Terms and Conditions of Sale or other applicable terms agreed to in writing. No use of any Renesas resources expands or otherwise alters any applicable warranties or warranty disclaimers for these products.

(Disclaimer Rev.1.01)

Corporate Headquarters

TOYOSU FORESIA, 3-2-24 Toyosu,
Koto-ku, Tokyo 135-0061, Japan
www.renesas.com

Trademarks

Renesas and the Renesas logo are trademarks of Renesas Electronics Corporation. All trademarks and registered trademarks are the property of their respective owners.

Contact Information

For further information on a product, technology, the most up-to-date version of a document, or your nearest sales office, please visit www.renesas.com/contact-us/.