

General Description

The ICS810252DI-02 is a PLL based synchronous multiplier that is optimized for PDH or SONET to Ethernet clock jitter attenuation and frequency translation. The device contains two internal frequency multiplication stages that are cascaded in series. The first stage is a VCXO PLL that is optimized to provide reference clock jitter attenuation. The second stage is a FemtoClock® frequency multiplier that provides the low jitter, high frequency Ethernet output clock that easily meets Gigabit and 10 Gigabit Ethernet jitter requirements. Pre-divider and output divider multiplication ratios are selected using device selection control pins. The multiplication ratios are optimized to support most common clock rates used in PDH, SONET and Ethernet applications. The VCXO requires the use of an external, inexpensive pullable crystal. The VCXO uses external passive loop filter components which allows configuration of the PLL loop bandwidth and damping characteristics. The device is packaged in a space-saving 32-VFQFN package and supports industrial temperature range.

Features

- Two LVCMOS/LVTTL outputs, 14Ω output impedance
Each output supports independent frequency selection at 25MHz, 125MHz, 156.25MHz and 312.5MHz
- Two differential input pairs support the following input types: LVPECL, LVDS, LVHSTL, SSTL, HCSL
- Accepts input frequencies from: 8kHz to 155.52MHz including 8kHz, 1.544MHz, 2.048MHz, 19.44MHz, 25MHz, 77.76MHz, 125MHz and 155.52MHz
- Attenuates the phase jitter of the input clock by using a low-cost pullable fundamental mode VCXO crystal
- VCXO PLL bandwidth can be optimized for jitter attenuation and reference tracking using external loop filter connection
- FemtoClock frequency multiplier provides low jitter, high frequency output
- Absolute pull range: ±50ppm
- FemtoClock VCO frequency: 625MHz
- RMS phase jitter @ 125MHz, using a 25MHz crystal (10kHz – 20MHz): 1.3ps (maximum)
- 3.3V supply voltage
- -40°C to 85°C ambient operating temperature
- Lead-free (RoHS 6) packaging
- **Not Recommended for New Designs. For new designs use 810N252I-02**

Pin Assignment

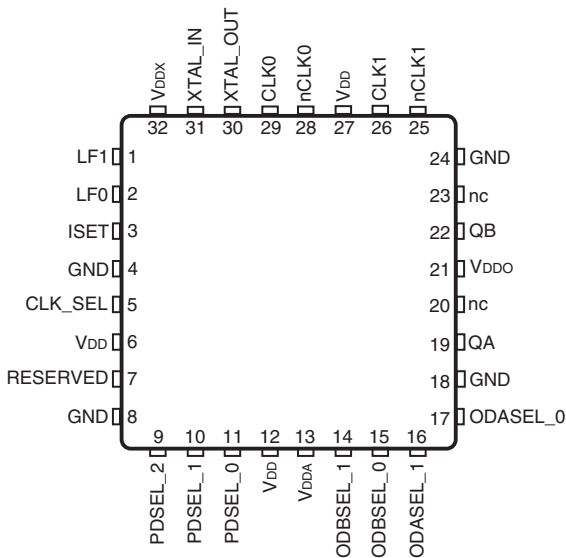

ICS810252DI-02

32 Lead VFQFN

5mm x 5mm x 0.925mm package body

K Package

Top View

Block Diagram

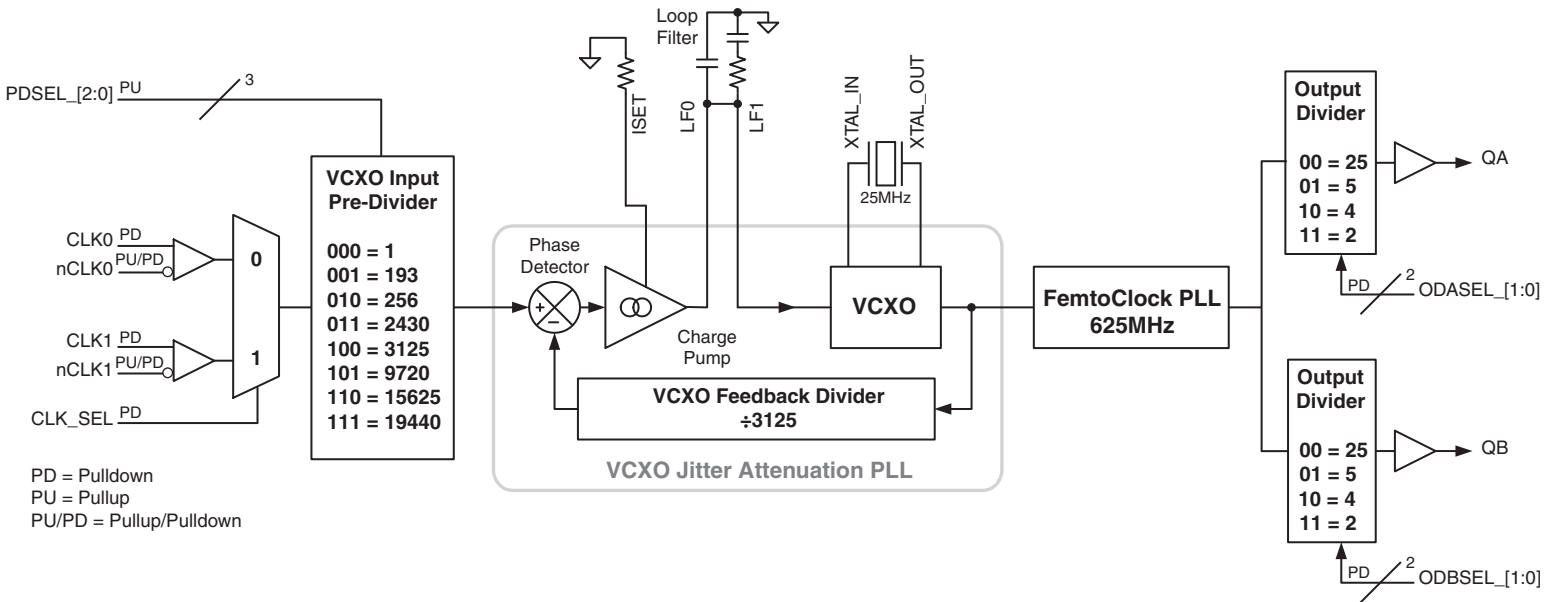

Table 1. Pin Descriptions

Number	Name	Type		Description
1, 2	LF1, LF0	Analog Input/Output		Loop filter connection node pins. LF0 is the output. LF1 is the input.
3	ISET	Analog Input/Output		Charge pump current setting pin.
4, 8, 18, 24	GND	Power		Power supply ground.
5	CLK_SEL	Input	Pulldown	Input clock select. When HIGH selects CLK1/nCLK1. When LOW, selects CLK0/nCLK0. LVCMOS / LVTTTL interface levels.
6, 12, 27	V _{DD}	Power		Core supply pins.
7	RESERVED	Reserved		Reserved pin. Do not connect.
9, 10, 11	PDSEL_2, PDSEL_1, PDSEL_0	Input	Pullup	Pre-divider select pins. LVCMOS/LVTTTL interface levels. See Table 3A.
13	V _{DDA}	Power		Analog supply pin.
14, 15	ODBSEL_1, ODBSEL_0	Input	Pulldown	Frequency select pin for Bank B output. See Table 3B. LVCMOS/LVTTTL interface levels.
16, 17	ODASEL_1, ODASEL_0	Input	Pulldown	Frequency select pin for Bank A output. See Table 3B. LVCMOS/LVTTTL interface levels.
19	QA	Output		Single-ended Bank A clock output. LVCMOS/LVTTTL interface levels.
20, 23	nc	Unused		No connect.
21	V _{DDO}	Power		Output supply pin.
22	QB	Output		Single-ended Bank B clock output. LVCMOS/LVTTTL interface levels.
25	nCLK1	Input	Pullup/ Pulldown	Inverting differential clock input. V _{DD} /2 bias voltage when left floating.
26	CLK1	Input	Pulldown	Non-inverting differential clock input.
28	nCLK0	Input	Pullup/ Pulldown	Inverting differential clock input. V _{DD} /2 bias voltage when left floating.
29	CLK0	Input	Pulldown	Non-inverting differential clock input.
30, 31	XTAL_OUT, XTAL_IN	Input		Crystal oscillator interface. XTAL_IN is the input. XTAL_OUT is the output.
32	V _{DDX}	Power		Power supply pin for VCXO charge pump.

NOTE: *Pullup* and *Pulldown* refer to internal input resistors. See Table 2, *Pin Characteristics*, for typical values.

Table 2. Pin Characteristics

Symbol	Parameter	Test Conditions	Minimum	Typical	Maximum	Units
C _{IN}	Input Capacitance			4		pF
C _{PD}	Power Dissipation Capacitance (per output)	V _{DD} = V _{DDX} = V _{DDO} = 3.465V		9	12	pF
R _{PULLUP}	Input Pullup Resistor			51		kΩ
R _{PULLDOWN}	Input Pulldown Resistor			51		kΩ
R _{OUT}	Output Impedance			14		Ω

Function Tables

Table 3A. Pre-Divider Selection Function Table

Inputs			Pre-Divider Value
PDSEL_2	PDSEL_1	PDSEL_0	
0	0	0	1
0	0	1	193
0	1	0	256
0	1	1	2430
1	0	0	3125
1	0	1	9720
1	1	0	15625
1	1	1	19440 (default)

Table 3B. Output Divider Function Table

Inputs		Output Divider Value
ODxSEL_1	ODxSEL_0	
0	0	25 (default)
0	1	5
1	0	4
1	1	2

Table 3C. Frequency Function Table

Input Frequency (MHz)	Pre-Divider Value	VCXO Frequency (MHz)	FemtoClock Feedback Divider Value	FemtoClock VCO Frequency (MHz)	Output Divider Value	Output Frequency (MHz)
0.008	1	25	25	625	25	25
0.008	1	25	25	625	5	125
0.008	1	25	25	625	4	156.25
0.008	1	25	25	625	2	312.5
1.544	193	25	25	625	25	25
1.544	193	25	25	625	5	125
1.544	193	25	25	625	4	156.25
1.544	193	25	25	625	2	312.5
2.048	256	25	25	625	25	25
2.048	256	25	25	625	5	125
2.048	256	25	25	625	4	156.25
2.048	256	25	25	625	2	312.5
19.44	2430	25	25	625	25	25
19.44	2430	25	25	625	5	125
19.44	2430	25	25	625	4	156.25
19.44	2430	25	25	625	2	312.5
25	3125	25	25	625	25	25
25	3125	25	25	625	5	125
25	3125	25	25	625	4	156.25
25	3125	25	25	625	2	312.5
77.76	9720	25	25	625	25	25
77.76	9720	25	25	625	5	125
77.76	9720	25	25	625	4	156.25
77.76	9720	25	25	625	2	312.5
125	15625	25	25	625	25	25
125	15625	25	25	625	5	125
125	15625	25	25	625	4	156.25
125	15625	25	25	625	2	312.5
155.52	19440	25	25	625	25	25
155.52	19440	25	25	625	5	125
155.52	19440	25	25	625	4	156.25
155.52	19440	25	25	625	2	312.5

Absolute Maximum Ratings

NOTE: Stresses beyond those listed under *Absolute Maximum Ratings* may cause permanent damage to the device. These ratings are stress specifications only. Functional operation of product at these conditions or any conditions beyond those listed in the *DC Characteristics* or *AC Characteristics* is not implied. Exposure to absolute maximum rating conditions for extended periods may affect product reliability.

Item	Rating
Supply Voltage, V_{DD}	4.6V
Inputs, V_I XTAL_IN Other Inputs	0V to V_{DD} -0.5V to $V_{DD} + 0.5V$
Outputs, V_O	-0.5V to $V_{DD} + 0.5V$
Package Thermal Impedance, θ_{JA}	37°C/W (0 mps)
Storage Temperature, T_{STG}	-65°C to 150°C

DC Electrical Characteristics

Table 4A. Power Supply DC Characteristics, $V_{DD} = V_{DDO} = V_{DDX} = 3.3V \pm 5\%$, $T_A = -40^\circ C$ to $85^\circ C$

Symbol	Parameter	Test Conditions	Minimum	Typical	Maximum	Units
V_{DD}	Core Supply Voltage		3.135	3.3	3.465	V
V_{DDA}	Analog Supply Voltage		$V_{DD} - 0.15$	3.3	V_{DD}	V
V_{DDO}	Output Supply Voltage		3.135	3.3	3.465	V
V_{DDX}	Charge Pump Supply Voltage		3.135	3.3	3.465	V
$I_{DD} + I_{DDX}$	Power Supply Current				206	mA
I_{DDA}	Analog Supply Current				15	mA
I_{DDO}	Output Supply Current	No Load			3	mA

Table 4B. LVCMOS/LVTTL DC Characteristics, $V_{DD} = V_{DDO} = V_{DDX} = 3.3V \pm 5\%$, $T_A = -40^\circ C$ to $85^\circ C$

Symbol	Parameter	Test Conditions	Minimum	Typical	Maximum	Units
V_{IH}	Input High Voltage		2		$V_{DD} + 0.3$	V
V_{IL}	Input Low Voltage		-0.3		0.8	V
I_{IH}	Input High Current	CLK_SEL, ODASEL_[1:0], ODBSEL_[1:0]	$V_{DD} = V_{IN} = 3.465V$		150	μA
		PDSEL[2:0]	$V_{DD} = V_{IN} = 3.465V$		5	μA
I_{IL}	Input Low Current	CLK_SEL, ODASEL_[1:0], ODBSEL_[1:0]	$V_{DD} = 3.465V, V_{IN} = 0V$	-5		μA
		PDSEL[2:0]	$V_{DD} = 3.465, V_{IN} = 0V$	-150		μA
V_{OH}	Output High Voltage; NOTE 1		2.6			V
V_{OL}	Output Low Voltage; NOTE 1				0.5	V

NOTE 1: Outputs terminated with 50Ω to $V_{DDO}/2$. See Parameter Measurement Information section. *Load Test Circuit diagrams*.

Table 4C. Differential DC Characteristics, $V_{DD} = V_{DDO} = V_{DDX} = 3.3V \pm 5\%$, $T_A = -40^\circ\text{C}$ to 85°C

Symbol	Parameter	Test Conditions	Minimum	Typical	Maximum	Units
I_{IH}	Input High Current	CLK0/nCLK0, CLK1/nCLK1	$V_{DD} = V_{IN} = 3.465V$		150	μA
I_{IL}	Input Low Current	CLK0, CLK1	$V_{DD} = 3.465V, V_{IN} = 0V$	-5		μA
		nCLK0, nCLK1	$V_{DD} = 3.465V, V_{IN} = 0V$	-150		μA
V_{PP}	Peak-to-Peak Input Voltage		0.15		1.3	V
V_{CMR}	Common Mode Input Voltage; NOTE 1		GND + 0.5		$V_{DD} - 0.85$	V

NOTE 1: Common mode voltage is defined as V_{IH} .

AC Electrical Characteristics

Table 5. AC Characteristics, $V_{DD} = V_{DDO} = V_{DDX} = 3.3V \pm 5\%$, $T_A = -40^\circ\text{C}$ to 85°C

Symbol	Parameter	Test Conditions	Minimum	Typical	Maximum	Units
f_{IN}	Input Frequency		0.008		155.52	MHz
f_{OUT}	Output Frequency		25		312.5	MHz
$f_{jit}(\emptyset)$	RMS Phase Jitter, (Random), NOTE 1, 2	125MHz f_{OUT} , 25MHz crystal, Integration Range: 10kHz – 20MHz		1.05	1.3	ps
$t_{sk(o)}$	Output Skew; NOTE 3, 4				200	ps
odc	Output Duty Cycle	$f_{OUT} \leq 156.25\text{MHz}$	45		55	%
t_R / t_F	Output Rise/Fall Time	20% to 80%	200		800	ps
t_{LOCK}	VCXO & FemtoClock PLL Lock Time; NOTE 5	Reference Clock Input is $\pm 50\text{ppm}$ from Nominal Frequency			2.5	S

NOTE: Electrical parameters are guaranteed over the specified ambient operating temperature range, which is established when the device is mounted in a test socket with maintained transverse airflow greater than 500 lpm. The device will meet specifications after thermal equilibrium has been reached under these conditions.

NOTE: Characterized with outputs at the same frequency using the loop filter components for the mid loop bandwidth. Refer to VCXO-PLL Loop Bandwidth Selection Table.

NOTE 1: Refer to the Phase Noise Plot.

NOTE 2: Not tested in production.

NOTE 3: This parameter is defined in accordance with JEDEC Standard 65.

NOTE 4: Defined as skew between outputs at the same supply voltage and with equal load conditions. Measured at $V_{DDO}/2$.

NOTE 5: Lock Time measured from power-up to stable output frequency.

Typical Phase Noise at 125MHz

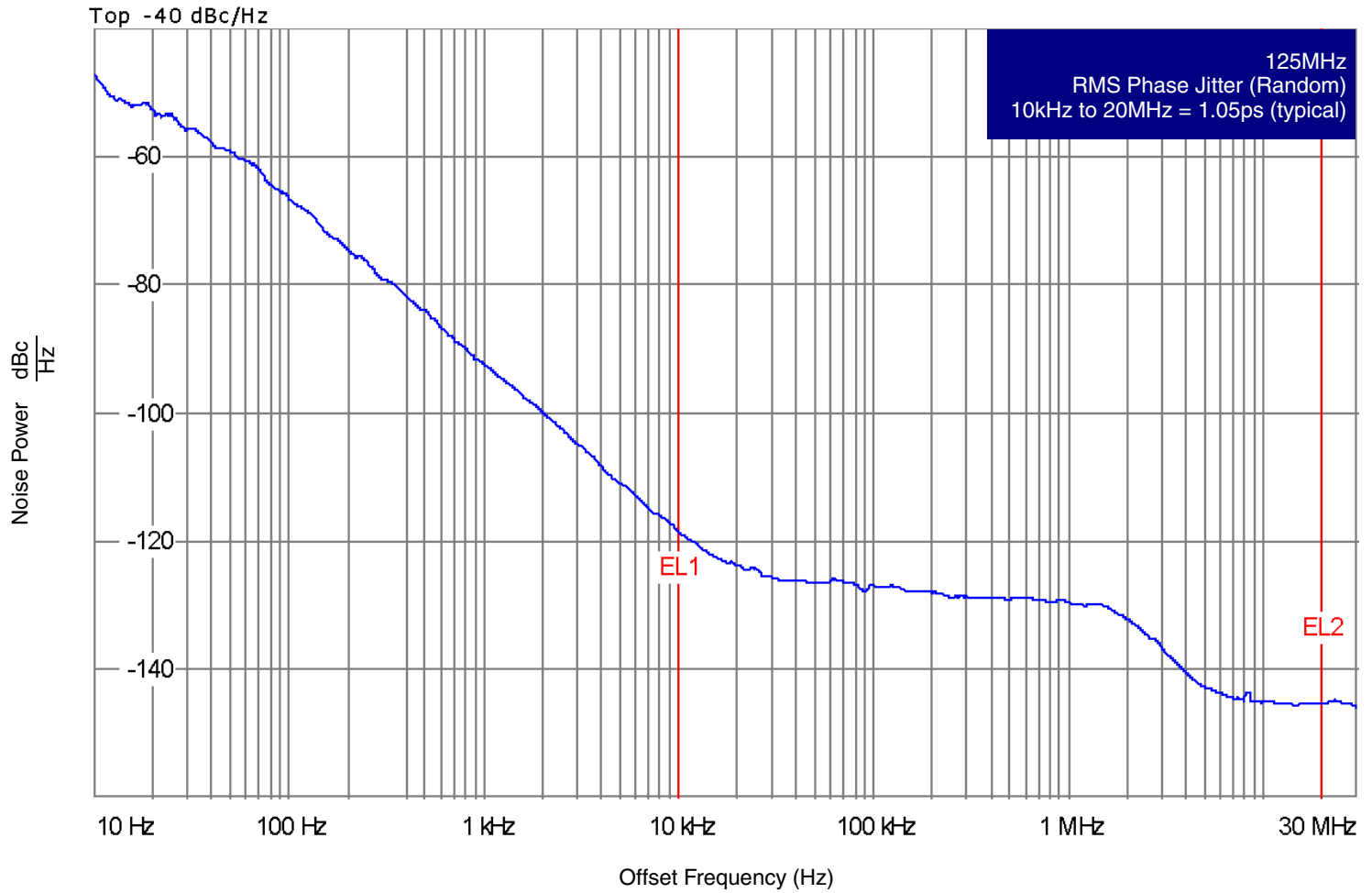

Parameter Measurement Information

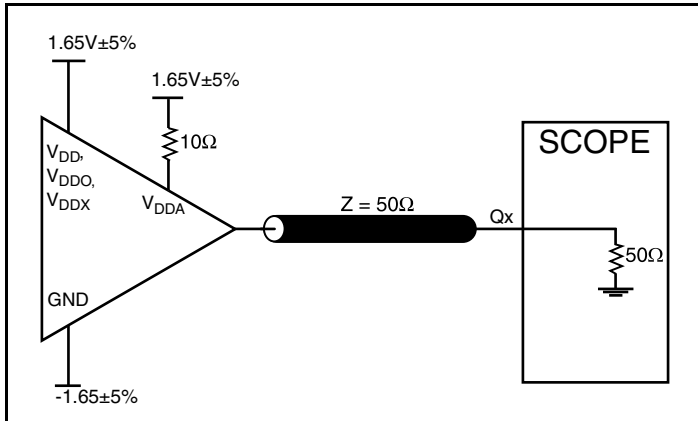

3.3V Output Load AC Test Circuit

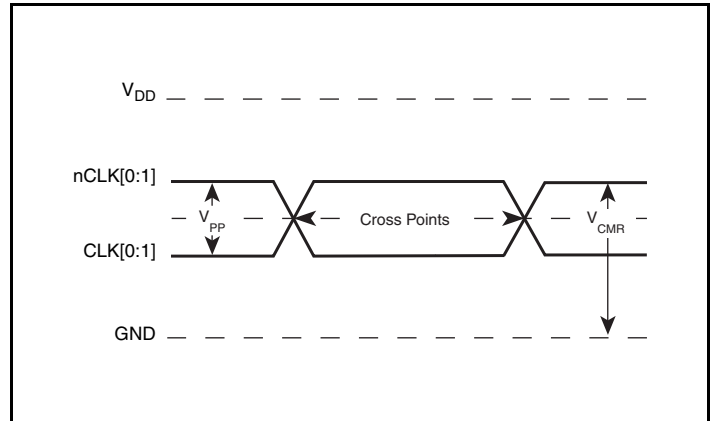

Differential Input Level

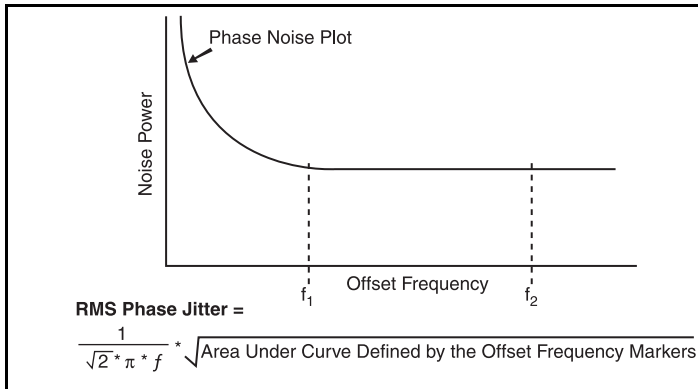

RMS Phase Jitter

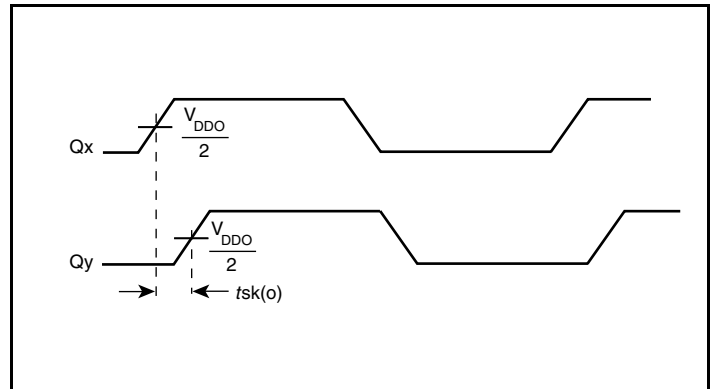

Output Skew

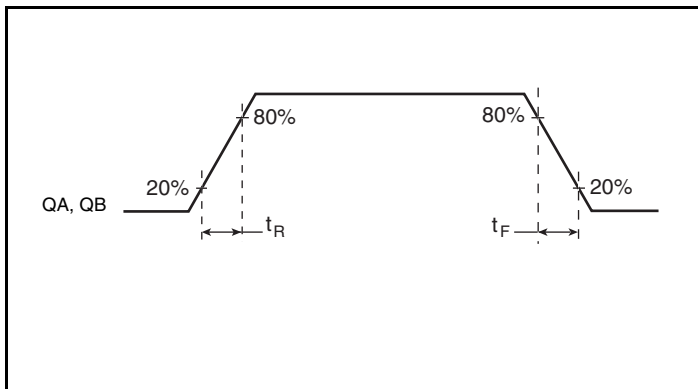

Output Rise/Fall Time

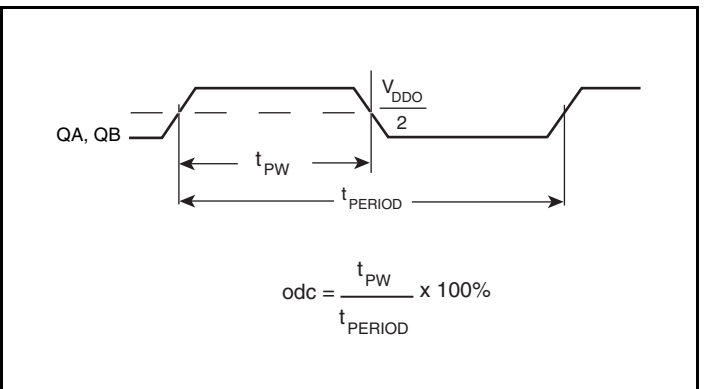

Output Duty Cycle/Pulse Width/Period

Parameter Measurement Information, continued

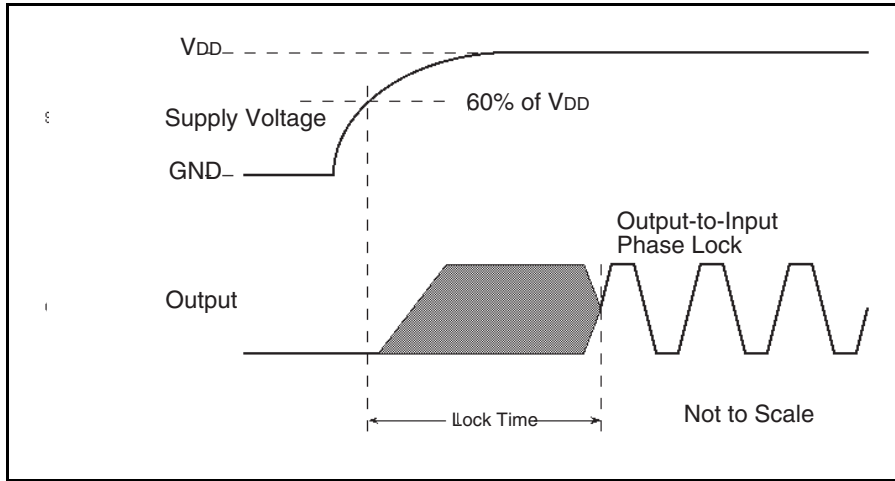

VCXO & FemtoClock PLL Lock Time

Application Information

Power Supply Filtering Technique

As in any high speed analog circuitry, the power supply pins are vulnerable to random noise. To achieve optimum jitter performance, power supply isolation is required. The ICS810252DI-02 provides separate power supplies to isolate any high switching noise from the outputs to the internal PLL. V_{DD} , V_{DDA} , V_{DDO} and V_{DDX} should be individually connected to the power supply plane through vias, and $0.01\mu\text{F}$ bypass capacitors should be used for each pin. *Figure 1* illustrates this for a generic V_{DD} pin and also shows that V_{DDA} requires that an additional 10Ω resistor along with a $10\mu\text{F}$ bypass capacitor be connected to the V_{DDA} pin.

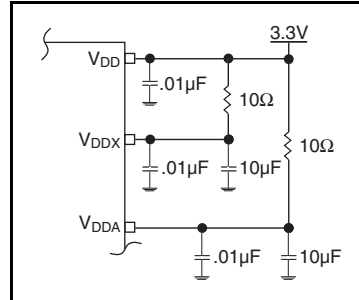

Figure 1. Power Supply Filtering

Wiring the Differential Input to Accept Single-Ended Levels

Figure 2 shows how a differential input can be wired to accept single ended levels. The reference voltage $V_1 = V_{DD}/2$ is generated by the bias resistors $R1$ and $R2$. The bypass capacitor ($C1$) is used to help filter noise on the DC bias. This bias circuit should be located as close to the input pin as possible. The ratio of $R1$ and $R2$ might need to be adjusted to position the V_1 in the center of the input voltage swing. For example, if the input clock swing is 2.5V and $V_{DD} = 3.3\text{V}$, $R1$ and $R2$ value should be adjusted to set V_1 at 1.25V . The values below are for when both the single ended swing and V_{DD} are at the same voltage. This configuration requires that the sum of the output impedance of the driver (R_o) and the series resistance (R_s) equals the transmission line impedance. In addition, matched termination at the input will attenuate the signal in half. This can be done in one of two ways. First, $R3$ and $R4$ in parallel should equal the transmission line

impedance. For most 50Ω applications, $R3$ and $R4$ can be 100Ω . The values of the resistors can be increased to reduce the loading for slower and weaker LVCMOS driver. When using single-ended signaling, the noise rejection benefits of differential signaling are reduced. Even though the differential input can handle full rail LVCMOS signaling, it is recommended that the amplitude be reduced. The datasheet specifies a lower differential amplitude, however this only applies to differential signals. For single-ended applications, the swing can be larger, however V_{IL} cannot be less than -0.3V and V_{IH} cannot be more than $V_{DD} + 0.3\text{V}$. Though some of the recommended components might not be used, the pads should be placed in the layout. They can be utilized for debugging purposes. The datasheet specifications are characterized and guaranteed by using a differential signal.

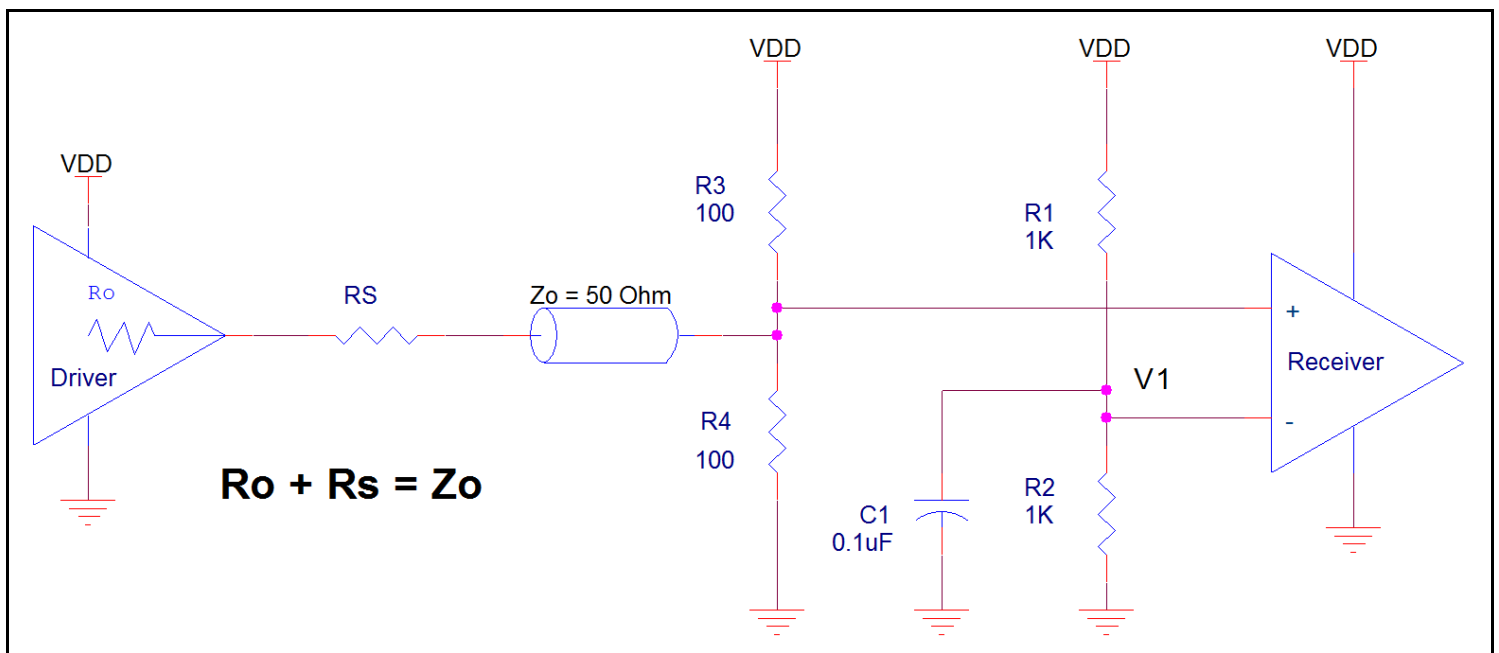

Figure 2. Recommended Schematic for Wiring a Differential Input to Accept Single-ended Levels

Differential Clock Input Interface

The CLK /nCLK accepts LVDS, LVPECL, LVHSTL, SSTL, HCSL and other differential signals. Both differential signals must meet the V_{PP} and V_{CMR} input requirements. Figures 3A to 3F show interface examples for the CLK/nCLK input driven by the most common driver types. The input interfaces suggested here are examples only.

Please consult with the vendor of the driver component to confirm the driver termination requirements. For example, in Figure 3A, the input termination applies for IDT open emitter LVHSTL drivers. If you are using an LVHSTL driver from another vendor, use their termination recommendation.

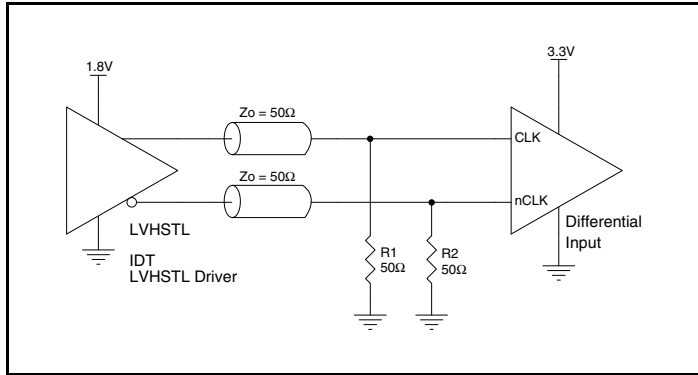

Figure 3A. CLK/nCLK Input Driven by an IDT Open Emitter LVHSTL Driver

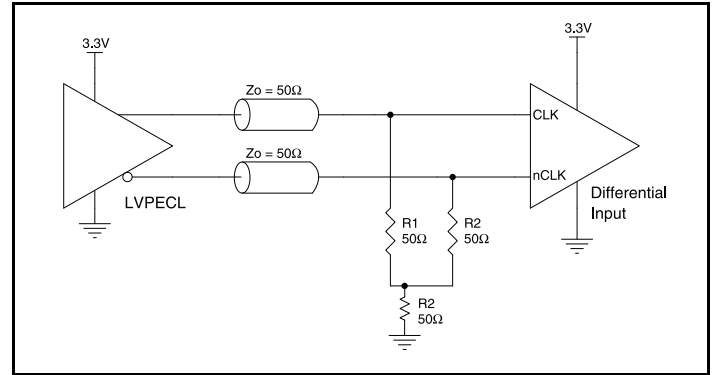

Figure 3B. CLK/nCLK Input Driven by a 3.3V LVPECL Driver

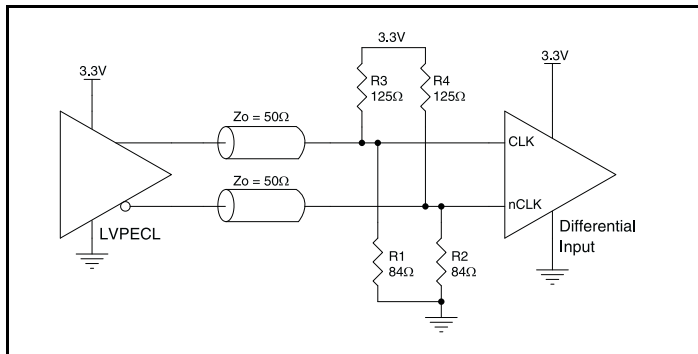

Figure 3C. CLK/nCLK Input Driven by a 3.3V LVPECL Driver

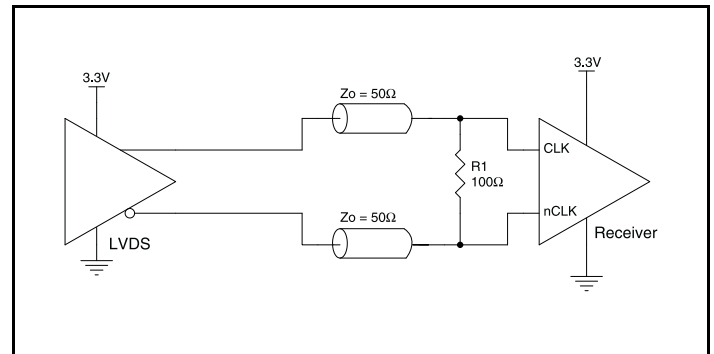

Figure 3D. CLK/nCLK Input Driven by a 3.3V LVDS Driver

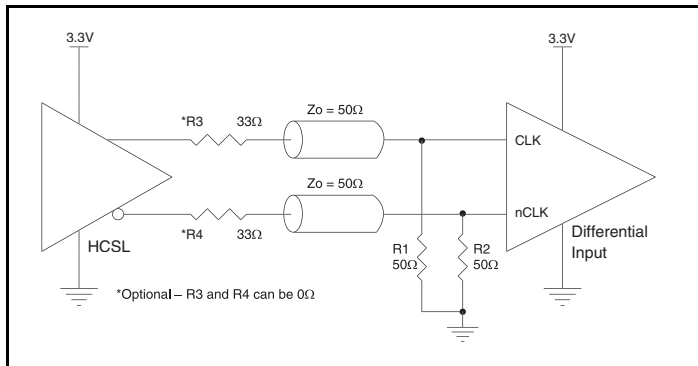

Figure 3E. CLK/nCLK Input Driven by a 3.3V HCSL Driver

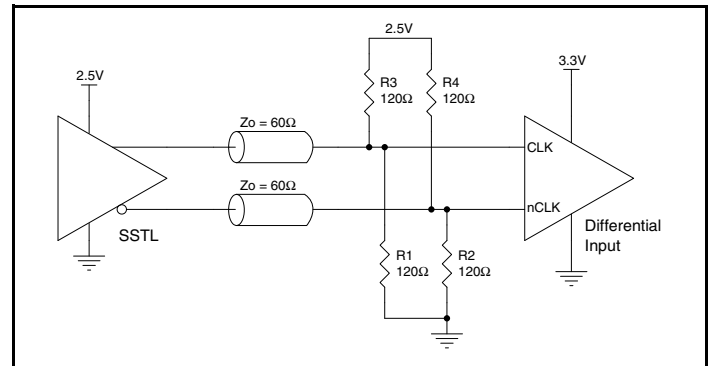

Figure 3F. CLK/nCLK Input Driven by a 2.5V SSTL Driver

Recommendations for Unused Input and Output Pins

Inputs:

CLK/nCLK Inputs

For applications not requiring the use of the differential input, both CLK and nCLK can be left floating. Though not required, but for additional protection, a 1k Ω resistor can be tied from CLK to ground.

LVC MOS Control Pins

All control pins have internal pullup or pulldown resistors; additional resistance is not required but can be added for additional protection. A 1k Ω resistor can be used.

Outputs:

LVC MOS Outputs

All unused LVC MOS outputs can be left floating. There should be no trace attached.

VFQFN EPAD Thermal Release Path

In order to maximize both the removal of heat from the package and the electrical performance, a land pattern must be incorporated on the Printed Circuit Board (PCB) within the footprint of the package corresponding to the exposed metal pad or exposed heat slug on the package, as shown in *Figure 4*. The solderable area on the PCB, as defined by the solder mask, should be at least the same size/shape as the exposed pad/slug area on the package to maximize the thermal/electrical performance. Sufficient clearance should be designed on the PCB between the outer edges of the land pattern and the inner edges of pad pattern for the leads to avoid any shorts.

While the land pattern on the PCB provides a means of heat transfer and electrical grounding from the package to the board through a solder joint, thermal vias are necessary to effectively conduct from the surface of the PCB to the ground plane(s). The land pattern must be connected to ground through these vias. The vias act as “heat pipes”. The number of vias (i.e. “heat pipes”) are application specific

and dependent upon the package power dissipation as well as electrical conductivity requirements. Thus, thermal and electrical analysis and/or testing are recommended to determine the minimum number needed. Maximum thermal and electrical performance is achieved when an array of vias is incorporated in the land pattern. It is recommended to use as many vias connected to ground as possible. It is also recommended that the via diameter should be 12 to 13mils (0.30 to 0.33mm) with 1oz copper via barrel plating. This is desirable to avoid any solder wicking inside the via during the soldering process which may result in voids in solder between the exposed pad/slug and the thermal land. Precautions should be taken to eliminate any solder voids between the exposed heat slug and the land pattern. Note: These recommendations are to be used as a guideline only. For further information, please refer to the Application Note on the Surface Mount Assembly of Amkor’s Thermally/Electrically Enhance Leadframe Base Package, Amkor Technology.

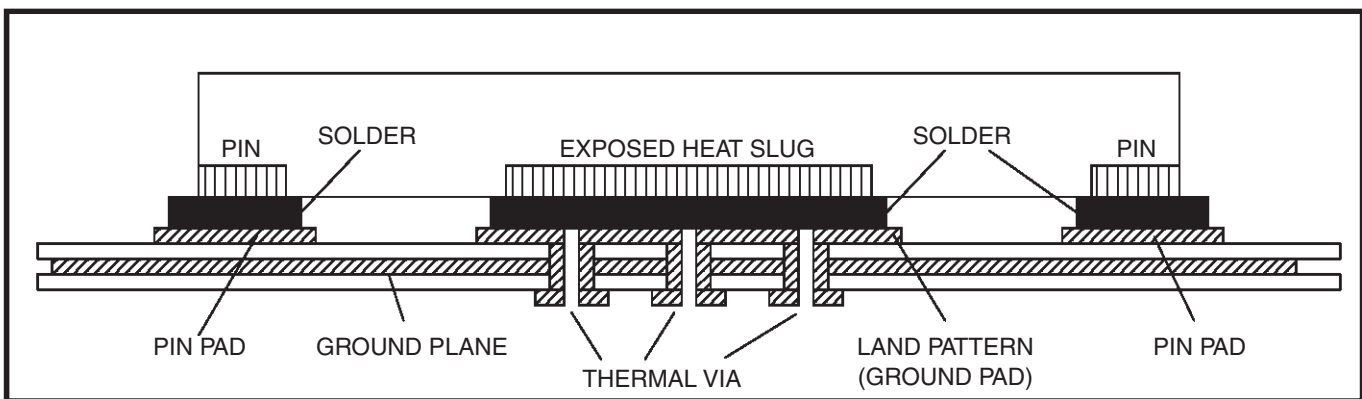

Figure 4. P.C. Assembly for Exposed Pad Thermal Release Path – Side View (drawing not to scale)

Schematic Example

Figure 5 shows an example of the 810252DI-02 application schematic. In this example, the device is operated at $V_{DD} = 3.3V$. The decoupling capacitors should be located as close as possible to the power pin. The input is driven by a 3.3V LVPECL driver. An optional

3-pole filter can also be used for additional spur reduction. It is recommended that the loop filter components be laid out for the 3-pole option. This will also allow the 2-pole filter to be used.

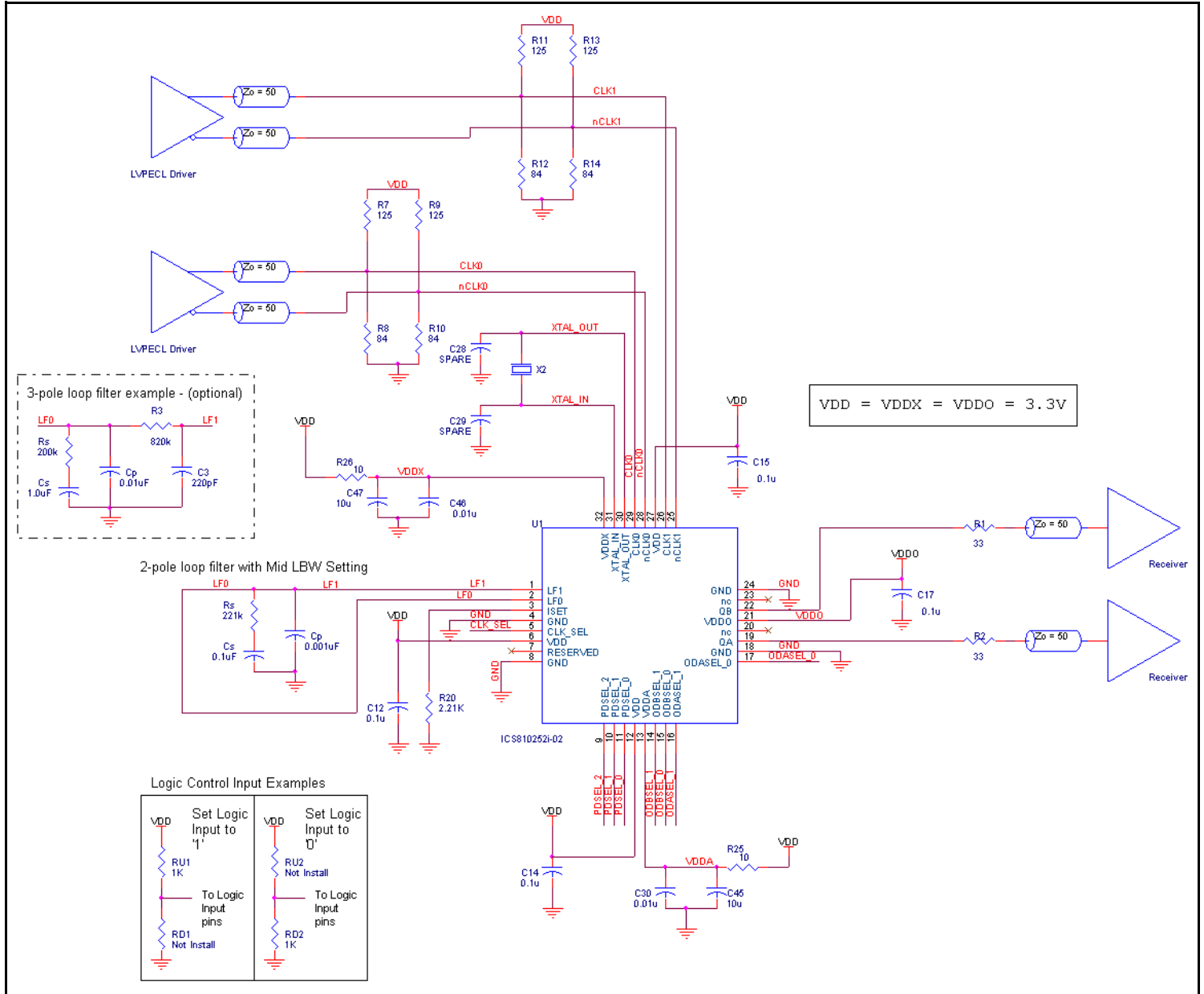

Figure 5. ICS810252DI-02 Schematic Example

VCXO-PLL EXTERNAL COMPONENTS

Choosing the correct external components and having a proper printed circuit board (PCB) layout is a key task for quality operation of the VCXO-PLL. In choosing a crystal, special precaution must be taken with the package and load capacitance (C_L). In addition, frequency, accuracy and temperature range must also be considered. Since the pulling range of a crystal also varies with the package, it is recommended that a metal-canned package like HC49 be used. Generally, a metal-canned package has a larger pulling range than a surface mounted device (SMD). For crystal selection information, refer to the *VCXO Crystal Selection Application Note*.

The crystal's load capacitance C_L characteristic determines its resonating frequency and is closely related to the VCXO tuning range. The total external capacitance seen by the crystal when installed on a board is the sum of the stray board capacitance, IC package lead capacitance, internal varactor capacitance and any installed tuning capacitors (C_{TUNE}).

If the crystal's C_L is greater than the total external capacitance, the VCXO will oscillate at a higher frequency than the crystal specification. If the crystal's C_L is lower than the total external capacitance, the VCXO will oscillate at a lower frequency than the crystal specification. In either case, the absolute tuning range is reduced. The correct value of C_L is dependent on the characteristics of the VCXO. The recommended C_L in the Crystal Parameter Table balances the tuning range by centering the tuning curve.

VCXO Characteristics Table

Symbol	Parameter	Typical	Units
k_{VCXO}	VCXO Gain	16,700	kHz/V
C_{V_LOW}	Low Varactor Capacitance	9.8	pF
C_{V_HIGH}	High Varactor Capacitance	22.9	pF

VCXO-PLL Loop Bandwidth Selection Table

Bandwidth	Crystal Frequency (MHz)	R_S (k Ω)	C_S (μ F)	C_P (μ F)	R_{SET} (k Ω)
10Hz (Low)	25	121	1.0	0.01	9.09
90Hz (Mid)	25	221	0.1	0.001	2.21
300Hz (High)	25	680	0.1	0.0001	2.21

NOTE: When configuring the ICS810252DI-02 with a PLL loop bandwidth less than 300Hz, it is recommended that CLK1, nCLK1 input be used as the only reference clock. In systems where both reference clocks are used, it is recommended to have a PLL loop bandwidths of 300Hz or greater.

The frequency of oscillation in the third overtone mode is not necessarily at exactly three times the fundamental frequency. The mechanical properties of the quartz element dictate the position of the overtones relative to the fundamental. The oscillator circuit may excite both the fundamental and overtone modes simultaneously. This will cause a nonlinearity in the tuning curve. This potential problem is why VCXO crystals are required to be tested for absence of any activity inside a ± 200 ppm window at three times the fundamental frequency. Refer to F_{L_3OVT} and $F_{L_3OVT_spurs}$ in the crystal Characteristics table.

The crystal and external loop filter components should be kept as close as possible to the device. Loop filter and crystal traces should be kept short and separated from each other. Other signal traces should be kept separate and not run underneath the device, loop filter or crystal components.

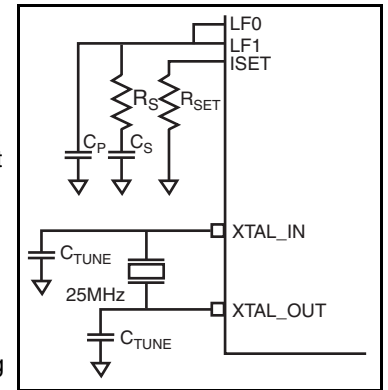

Crystal Characteristics

Symbol	Parameter	Test Conditions	Minimum	Typical	Maximum	Units
	Mode of Oscillation		Fundamental			
f_N	Frequency			25		MHz
f_T	Frequency Tolerance				±20	ppm
f_S	Frequency Stability				±20	ppm
	Operating Temperature Range		-40		85	⁰ C
C_L	Load Capacitance			10		pF
C_O	Shunt Capacitance			4		pF
C_O / C_1	Pullability Ratio			220	240	
F_{L_3OVT}	3 RD Overtone F_L		200			ppm
$F_{L_3OVT_spurs}$	3 RD Overtone F_L Spurs		200			ppm
ESR	Equivalent Series Resistance				20	Ω
	Drive Level				1	mW
	Aging @ 25 ⁰ C				±3 per year	ppm

Reliability Information

Table 6. θ_{JA} vs. Air Flow Table for a 32 Lead VFQFN

θ_{JA} vs. Air Flow			
Meters per Second	0	1	2.5
Multi-Layer PCB, JEDEC Standard Test Boards	37.0°C/W	32.4°C/W	29°C/W

Transistor Count

The transistor count for ICS810252DI-02 is: 6673

Package Outline and Package Dimensions

Package Outline - K Suffix for 32 Lead VFQFN

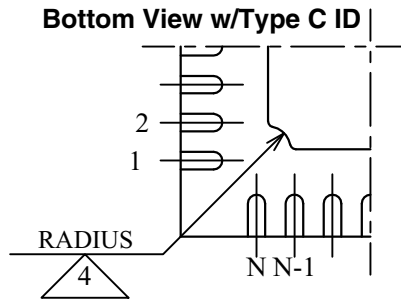
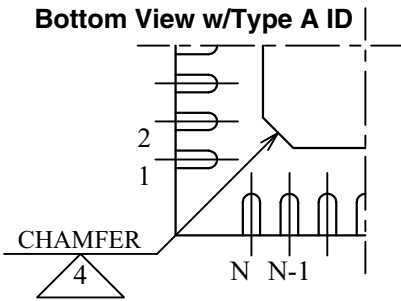
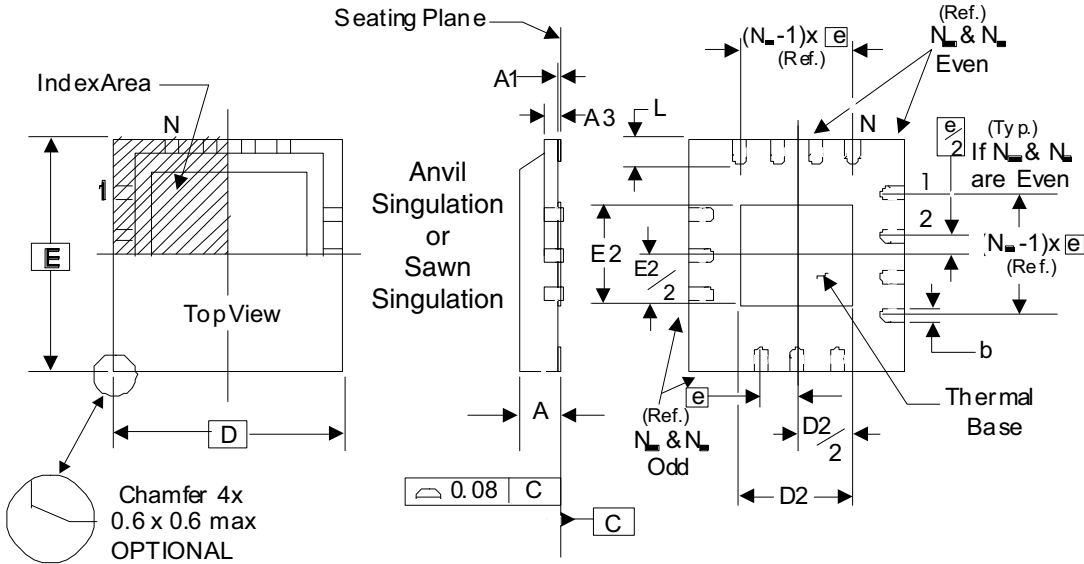

There are 2 methods of indicating pin 1 corner at the back of the VFQFN package:

1. Type A: Chamfer on the paddle (near pin 1)
2. Type C: Mouse bite on the paddle (near pin 1)

Table 7. Package Dimensions

JEDEC Variation: VHHD-2/-4			
All Dimensions in Millimeters			
Symbol	Minimum	Nominal	Maximum
N	32		
A	0.80		1.00
A1	0		0.05
A3	0.25 Ref.		
b	0.18	0.25	0.30
N_D & N_E	8		
D & E	5.00 Basic		
D2 & E2	3.0		3.3
e	0.50 Basic		
L	0.30	0.40	0.50

NOTE: The following package mechanical drawing is a generic drawing that applies to any pin count VFQFN package. This drawing is not intended to convey the actual pin count or pin layout of this device. The pin count and pinout are shown on the front page. The package dimensions are in Table 7.

Reference Document: JEDEC Publication 95, MO-220

Ordering Information

Table 8. Ordering Information

Part/Order Number	Marking	Package	Shipping Packaging	Temperature
810252DKI-02LF	ICS252DI02L	"Lead-Free" 32 Lead VFQFN	Tray	-40°C to 85°C
810252DKI-02LFT	ICS252DI02L	"Lead-Free" 32 Lead VFQFN	Tape & Reel	-40°C to 85°C

Revision History Sheet

Rev	Table	Page	Description of Change	Date
A		1	General Description - deleted HiperClocks Logo.	4/8/2013
		11	Updated application note, <i>Wiring the Differential Inputs to Accept Single-ended Levels</i> .	
		15	VCXO-PLL Loop Bandwidth Selection table - added note.	
A		1	NRND - Not Recommended for New Designs - for new designs use 810N252I-02.	4/7/14
B	T8	19	Ordering Information - Updated Marking for 810252DKI-02LFT. Updated Data Sheet format.	11/18/14



Corporate Headquarters
6024 Silver Creek Valley Road
San Jose, CA 95138 USA

Sales
1-800-345-7015 or 408-284-8200
Fax: 408-284-2775
www.IDT.com

Tech Support
email: clocks@idt.com

DISCLAIMER Integrated Device Technology, Inc. (IDT) and its subsidiaries reserve the right to modify the products and/or specifications described herein at any time and at IDT's sole discretion. All information in this document, including descriptions of product features and performance, is subject to change without notice. Performance specifications and the operating parameters of the described products are determined in the independent state and are not guaranteed to perform the same way when installed in customer products. The information contained herein is provided without representation or warranty of any kind, whether express or implied, including, but not limited to, the suitability of IDT's products for any particular purpose, an implied warranty of merchantability, or non-infringement of the intellectual property rights of others. This document is presented only as a guide and does not convey any license under intellectual property rights of IDT or any third parties.

IDT's products are not intended for use in applications involving extreme environmental conditions or in life support systems or similar devices where the failure or malfunction of an IDT product can be reasonably expected to significantly affect the health or safety of users. Anyone using an IDT product in such a manner does so at their own risk, absent an express, written agreement by IDT.

While the information presented herein has been checked for both accuracy and reliability, Integrated Device Technology (IDT) assumes no responsibility for either its use or for the infringement of any patents or other rights of third parties, which would result from its use. No other circuits, patents, or licenses are implied. This product is intended for use in normal commercial applications. Any other applications, such as those requiring extended temperature ranges, high reliability or other extraordinary environmental requirements are not recommended without additional processing by IDT. IDT reserves the right to change any circuitry or specifications without notice. IDT does not authorize or warrant any IDT product for use in life support devices or critical medical instruments.

Integrated Device Technology, IDT and the IDT logo are registered trademarks of IDT. Product specification subject to change without notice. Other trademarks and service marks used herein, including protected names, logos and designs, are the property of IDT or their respective third party owners.

Copyright ©2014 Integrated Device Technology, Inc.. All rights reserved.

IMPORTANT NOTICE AND DISCLAIMER

RENESAS ELECTRONICS CORPORATION AND ITS SUBSIDIARIES (“RENESAS”) PROVIDES TECHNICAL SPECIFICATIONS AND RELIABILITY DATA (INCLUDING DATASHEETS), DESIGN RESOURCES (INCLUDING REFERENCE DESIGNS), APPLICATION OR OTHER DESIGN ADVICE, WEB TOOLS, SAFETY INFORMATION, AND OTHER RESOURCES “AS IS” AND WITH ALL FAULTS, AND DISCLAIMS ALL WARRANTIES, EXPRESS OR IMPLIED, INCLUDING, WITHOUT LIMITATION, ANY IMPLIED WARRANTIES OF MERCHANTABILITY, FITNESS FOR A PARTICULAR PURPOSE, OR NON-INFRINGEMENT OF THIRD-PARTY INTELLECTUAL PROPERTY RIGHTS.

These resources are intended for developers who are designing with Renesas products. You are solely responsible for (1) selecting the appropriate products for your application, (2) designing, validating, and testing your application, and (3) ensuring your application meets applicable standards, and any other safety, security, or other requirements. These resources are subject to change without notice. Renesas grants you permission to use these resources only to develop an application that uses Renesas products. Other reproduction or use of these resources is strictly prohibited. No license is granted to any other Renesas intellectual property or to any third-party intellectual property. Renesas disclaims responsibility for, and you will fully indemnify Renesas and its representatives against, any claims, damages, costs, losses, or liabilities arising from your use of these resources. Renesas' products are provided only subject to Renesas' Terms and Conditions of Sale or other applicable terms agreed to in writing. No use of any Renesas resources expands or otherwise alters any applicable warranties or warranty disclaimers for these products.

(Disclaimer Rev.1.01)

Corporate Headquarters

TOYOSU FORESIA, 3-2-24 Toyosu,
Koto-ku, Tokyo 135-0061, Japan
www.renesas.com

Trademarks

Renesas and the Renesas logo are trademarks of Renesas Electronics Corporation. All trademarks and registered trademarks are the property of their respective owners.

Contact Information

For further information on a product, technology, the most up-to-date version of a document, or your nearest sales office, please visit www.renesas.com/contact-us/.