

GENERAL DESCRIPTION

The 8344 is a low voltage, low skew, 1-to-24 Differential-to-LVCMOS Fanout Buffer. The 8344 is designed to translate any differential signal levels to LVCMOS levels. The low impedance LVCMOS outputs are designed to drive 50Ω series or parallel terminated transmission lines. The effective fanout can be increased to 48 by utilizing the ability of the outputs to drive two series terminated lines. Redundant clock applications can make use of the dual clock input. The dual clock inputs also facilitate board level testing. 8344 is characterized at full 3.3V, full 2.5V and mixed 3.3V input and 2.5V output operating supply modes.

Guaranteed output and part-to-part skew characteristics make the 8344 ideal for those clock distribution applications demanding well defined performance and repeatability.

FEATURES

- Twenty-four LVCMOS outputs, 7Ω typical output impedance
- Selectable differential clock input pairs for redundant clock applications
- CLKx, nCLKx pairs can accept the following differential input levels: LVDS, LVPECL, LVHSTL, SSTL, HCSL
- Maximum output frequency: 167MHz
- Translates any differential input signal (LVPECL, LVHSTL, LVDS) to LVCMOS without external bias networks
- Translates any single-ended input signal to LVCMOS with resistor bias on nCLK input
- Multiple output enable pins for disabling unused outputs in reduced fanout applications
- Output skew: 275ps (maximum)
- Part-to-part skew: 600ps (maximum)
- Bank skew: 150ps (maximum)
- Propagation Delay: 4.3ns (maximum)
- 3.3V, 2.5V or mixed 3.3V, 2.5V operating supply modes
- 0°C to 70°C ambient operating temperature
- Available in lead-free (RoHS 6) package

BLOCK DIAGRAM

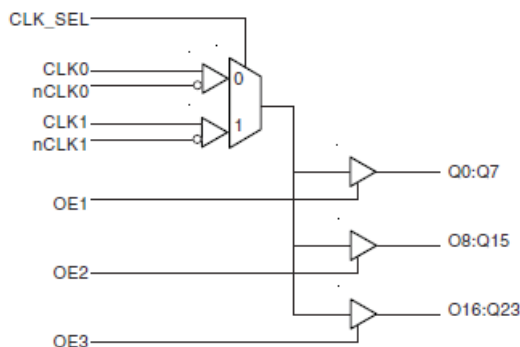

PIN ASSIGNMENT

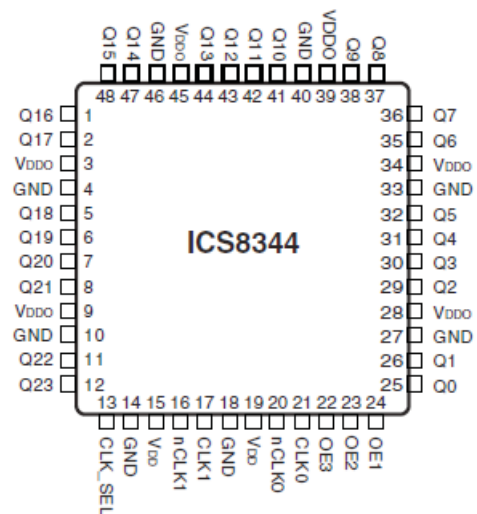

48-Lead LQFP
7mm x 7mm x 1.4mm package body
Y Package
Top View

TABLE 1. PIN DESCRIPTIONS

Number	Name	Type		Description
1, 2, 5, 6 7, 8, 11, 12	Q16, Q17, Q18, Q19 Q20, Q21, Q22, Q23	Output		Q15 thru Q23 outputs. 7Ω typical output impedance.
3, 9, 28, 34, 39, 45	V _{DDO}	Power		Output supply pins. Connect 3.3V or 2.5V.
4, 10, 14, 18, 27, 33, 40, 46	GND	Power		Power supply ground. Connect to ground.
13	CLK_SEL	Input	Pulldown	Clock select input. When HIGH, selects CLK1, nCLK1 inputs. When LOW, selects CLK0, nCLK0 inputs.
15, 19	V _{DD}	Power		Positive supply pins. Connect 3.3V or 2.5V.
16	nCLK1	Input	Pullup	Inverting input of secondary differential clock input pair.
17	CLK1	Input	Pulldown	Non-inverting input of secondary differential clock input pair.
20	nCLK0	Input	Pullup	Inverting input of primary differential clock input pair.
21	CLK0	Input	Pulldown	Non-inverting input of primary differential clock input pair.
22	OE3	Input	Pullup	Output enable. Controls enabling and disabling of outputs Q16 thru Q23.
23	OE2	Input	Pullup	Output enable. Controls enabling and disabling of outputs Q8 thru Q15.
24	OE1	Input	Pullup	Output enable. Controls enabling and disabling of outputs Q0 thru Q7.
25, 26, 29, 30 31, 32, 35, 36	Q0, Q1, Q2, Q3 Q4, Q5, Q6, Q7	Output		Q0 thru Q7 outputs. 7Ω typical output impedance.
37, 38, 41, 42 43, 44, 47, 48	Q8, Q9, Q10, Q11 Q12, Q13, Q14, Q15	Output		Q8 thru Q15 outputs. 7Ω typical output impedance.

NOTE: Pullup and Pulldown refer to internal input resistors. See Table 2, Pin Characteristics, for typical values.

TABLE 2. PIN CHARACTERISTICS

Symbol	Parameter	Test Conditions	Minimum	Typical	Maximum	Units
C _{IN}	Input Capacitance				4	pF
C _{PD}	Power Dissipation Capacitance (per output)	V _{DD} , V _{DDO} = 3.465V				pF
		V _{DD} = 3.465V, V _{DDO} = 2.625V				pF
		V _{DD} , V _{DDO} = 2.625V				pF
R _{PULLUP}	Input Pullup Resistor			51		kΩ
R _{PULLDOWN}	Input Pulldown Resistor			51		kΩ
R _{OUT}	Output Impedance			7		Ω

TABLE 3A. OUTPUT ENABLE FUNCTION TABLE

Bank 1		Bank 2		Bank 3	
Input	Output	Input	Output	Input	Output
OE1	Q0-Q7	OE2	Q8-Q15	OE3	Q16-Q23
0	Hi-Z	0	Hi-Z	0	Hi-Z
1	Active	1	Active	1	Active

TABLE 3B. CLOCK SELECT FUNCTION TABLE

Control Input	Clock	
CLK_SEL	CLK0, nCLK0	CLK1, nCLK1
0	Selected	De-selected
1	De-selected	Selected

TABLE 3C. CLOCK INPUTS FUNCTION TABLE

Inputs			Outputs	Input to Output Mode	Polarity
OE1, OE2, OE3	CLK	nCLK	Q0 thru Q23		
1	0	1	LOW	Differential to Single Ended	Non Inverting
1	1	0	HIGH	Differential to Single Ended	Non Inverting
1	0	Biased; NOTE 1	LOW	Single Ended to Differential	Non Inverting
1	1	Biased; NOTE 1	HIGH	Single Ended to Differential	Non Inverting
1	Biased; NOTE 1	0	HIGH	Single Ended to Differential	Inverting
1	Biased; NOTE 1	1	LOW	Single Ended to Differential	Inverting

NOTE 1: Please refer to the Application Information section, "Wiring the Differential Input to Accept Single Ended Levels".

ABSOLUTE MAXIMUM RATINGS

Supply Voltage, V_{DDx}	4.6V
Inputs, V_I	-0.5V to $V_{DD} + 0.5V$
Outputs, V_O	-0.5V to $V_{DDO} + 0.5V$
Package Thermal Impedance, θ_{JA}	47.9°C/W (0 lfpm)
Storage Temperature, T_{STG}	-65°C to 150°C

Stresses beyond those listed under Absolute Maximum Ratings may cause permanent damage to the device. These ratings are stress specifications only. Functional operation of product at these conditions or any conditions beyond those listed in the *DC Characteristics* or *AC Characteristics* is not implied. Exposure to absolute maximum rating conditions for extended periods may affect product reliability.

TABLE 4A. POWER SUPPLY DC CHARACTERISTICS, $V_{DD} = V_{DDO} = 3.3V \pm 5\%$, $T_A = 0^\circ C$ TO $70^\circ C$

Symbol	Parameter	Test Conditions	Minimum	Typical	Maximum	Units
V_{DD}	Positive Supply Voltage		3.135	3.3	3.465	V
V_{DDO}	Output Supply Voltage		3.135	3.3	3.465	V
I_{DD}	Positive Supply Current				120	mA

TABLE 4B. LVCMOS DC CHARACTERISTICS, $V_{DD} = V_{DDO} = 3.3V \pm 5\%$, $T_A = 0^\circ C$ TO $70^\circ C$

Symbol	Parameter	Test Conditions	Minimum	Typical	Maximum	Units
V_{IH}	Input High Voltage	CLK_SEL, OE1, OE2, OE3	2		$V_{DD} + 0.3$	V
V_{IL}	Input Low Voltage	CLK_SEL, OE1, OE2, OE3	-0.3		0.8	V
I_{IH}	Input High Current	OE1, OE2, OE3	$V_{DD} = V_{IN} = 3.465V$		5	μA
		CLK_SEL	$V_{DD} = V_{IN} = 3.465V$		150	μA
I_{IL}	Input Low Current	OE1, OE2, OE3	$V_{DD} = 3.465, V_{IN} = 0V$	-150		μA
		CLK_SEL	$V_{DD} = 3.465, V_{IN} = 0$	-5		μA
V_{OH}	Output High Voltage	$V_{DD} = V_{DDO} = 3.135V$ $I_{OH} = -36mA$	2.6			V
V_{OL}	Output Low Voltage	$V_{DD} = V_{DDO} = 3.135V$ $I_{OL} = 36mA$			0.6	V

TABLE 4C. DIFFERENTIAL DC CHARACTERISTICS, $V_{DD} = V_{DDO} = 3.3V \pm 5\%$, $T_A = 0^\circ C$ TO $70^\circ C$

Symbol	Parameter	Test Conditions	Minimum	Typical	Maximum	Units
I_{IH}	Input High Current	nCLK0, nCLK1			5	μA
		CLK0, CLK1			150	μA
I_{IL}	Input Low Current	nCLK0, nCLK1		-150		μA
		CLK0, CLK1		-5		μA
V_{PP}	Peak-to-Peak Input Voltage		0.15		1.3	V
V_{CMR}	Common Mode Input Voltage; Note 1, 2		GND + 0.5		$V_{DD} - 0.85$	V

NOTE 1: Common mode voltage is defined as V_{IH} .

NOTE 2: For single ended applications, the maximum input voltage for CLKx, nCLKx is $V_{DD} + 0.3V$.

TABLE 5A. AC CHARACTERISTICS, $V_{DD} = V_{DDO} = 3.3V \pm 5\%$, $T_A = 0^\circ C$ TO $70^\circ C$

Symbol	Parameter	Test Conditions	Minimum	Typical	Maximum	Units
f_{MAX}	Output Frequency				167	MHz
t_{pLH}	Propagation Delay Low-to-High; NOTE 1	$f \leq 167MHz$	2.6		4.3	ns
t_{pHL}	Propagation Delay High-to-Low; NOTE 1	$f \leq 167MHz$	2.4		4.3	ns
$tsk(b)$	Bank Skew; NOTE 2, 6	Measured on the rising edge of $V_{DDO}/2$			150	ps
$tsk(o)$	Output Skew; NOTE 3, 6	Measured on the rising edge of $V_{DDO}/2$			275	ps
$tsk(pp)$	Part-to-Part Skew; NOTE 4, 6	Measured on the rising edge of $V_{DDO}/2$			600	ps
t_R	Output Rise Time; NOTE 5	30% to 70%	200		1000	ps
t_F	Output Fall Time; NOTE 5	30% to 70%	200		1000	ps
t_{PW}	Output Pulse Width	$f \leq 167MHz$	tPeriod/2 - 0.65	tPeriod/2	tPeriod/2 + 0.65	ns
		$f = 167MHz$	2.35	2.5	3.65	ns
t_{EN}	Output Enable Time; NOTE 5	$f = 66.7MHz$			5	ns
t_{DIS}	Output Disable Time; NOTE 5	$f = 66.7MHz$			4	ns

All parameters measured at 167MHz unless noted otherwise.

NOTE 1: Measured from the differential input crossing point to the output at $V_{DDO}/2$.

NOTE 2: Defined as skew within a bank of outputs at the same voltages and with equal load conditions.

NOTE 3: Defined as skew between outputs at the same supply voltage and with equal load conditions.

NOTE 4: Defined as the skew between outputs on different devices operating at the same supply voltages and with equal load conditions. Using the same type of inputs on each device, the outputs are measured at $V_{DDO}/2$.

NOTE 5: These parameters are guaranteed by characterization. Not tested in production.

NOTE 6: This parameter is defined in accordance with JEDEC Standard 65.

TABLE 4D. POWER SUPPLY DC CHARACTERISTICS, $V_{DD} = 3.3V \pm 5\%$, $V_{DDO} = 2.5V \pm 5\%$, $T_A = 0^\circ\text{C}$ TO 70°C

Symbol	Parameter	Test Conditions	Minimum	Typical	Maximum	Units
V_{DD}	Positive Supply Voltage		3.135	3.3	3.465	V
V_{DDO}	Output Supply Voltage		2.375	2.5	2.625	V
I_{DD}	Positive Supply Current				120	mA

TABLE 4E. LVCMOS DC CHARACTERISTICS, $V_{DD} = 3.3V \pm 5\%$, $V_{DDO} = 2.5V \pm 5\%$, $T_A = 0^\circ\text{C}$ TO 70°C

Symbol	Parameter	Test Conditions	Minimum	Typical	Maximum	Units
V_{IH}	Input High Voltage	CLK_SEL, OE1, OE2, OE3	2		$V_{DD} + 0.3$	V
V_{IL}	Input Low Voltage	CLK_SEL, OE1, OE2, OE3	-0.3		0.8	V
I_{IH}	Input High Current	OE1, OE2, OE3	$V_{DD} = V_{IN} = 3.465V$		5	μA
		CLK_SEL	$V_{DD} = V_{IN} = 3.465V$		150	μA
I_{IL}	Input Low Current	OE1, OE2, OE3	$V_{DD} = 3.465V, V_{IN} = 0V$	-150		μA
		CLK_SEL	$V_{DD} = 3.465V, V_{IN} = 0V$	-5		μA
V_{OH}	Output High Voltage	$V_{DD} = 3.135V$ $V_{DDO} = 2.375V$ $I_{OH} = -27\text{mA}$	1.8			V
V_{OL}	Output Low Voltage	$V_{DD} = 3.135V$ $V_{DDO} = 2.375V$ $I_{OL} = 27\text{mA}$			0.63	V

TABLE 4F. DIFFERENTIAL DC CHARACTERISTICS, $V_{DD} = 3.3V \pm 5\%$, $V_{DDO} = 2.5V \pm 5\%$, $T_A = 0^\circ\text{C}$ TO 70°C

Symbol	Parameter	Test Conditions	Minimum	Typical	Maximum	Units
I_{IH}	Input High Current	nCLK0, nCLK1			5	μA
		CLK0, CLK1			150	μA
I_{IL}	Input Low Current	nCLK0, nCLK1			-150	μA
		CLK0, CLK1			-5	μA
V_{PP}	Peak-to-Peak Input Voltage		0.3		1.3	V
V_{CMR}	Common Mode Input Voltage; Note 1, 2		GND + 0.5		$V_{DD} - 0.85$	V

NOTE 1: Common mode voltage is defined as V_{IH} .NOTE 2: For single ended applications, the maximum input voltage for CLKx, nCLKx is $V_{DD} + 0.3V$.

TABLE 5B. AC CHARACTERISTICS, $V_{DD} = 3.3V \pm 5\%$, $V_{DDO} = 2.5V \pm 5\%$, $T_A = 0^\circ\text{C}$ TO 70°C

Symbol	Parameter	Test Conditions	Minimum	Typical	Maximum	Units
f_{MAX}	Output Frequency				167	MHz
t_{pLH}	Propagation Delay Low-to-High; NOTE 1	$f \leq 167\text{MHz}$	2.6		4.5	ns
t_{pHL}	Propagation Delay High-to-Low; NOTE 1	$f \leq 167\text{MHz}$	2.6		4.2	ns
$t_{sk(b)}$	Bank Skew; NOTE 2, 6	Measured on the rising edge of $V_{DDO}/2$			150	ps
$t_{sk(o)}$	Output Skew; NOTE 3, 6	Measured on the rising edge of $V_{DDO}/2$			275	ps
$t_{sk(pp)}$	Part-to-Part Skew; NOTE 4, 6	Measured on the rising edge of $V_{DDO}/2$			600	ps
t_R	Output Rise Time; NOTE 5	30% to 70%	300		1700	ps
t_F	Output Fall Time; NOTE 5	30% to 70%	300		1400	ps
t_{PW}	Output Pulse Width	$f \leq 167\text{MHz}$	tPeriod/2 - 0.65	tPeriod/2	tPeriod/2 + 0.65	ns
		$f = 167\text{MHz}$	2.35		3.65	ns
t_{EN}	Output Enable Time; NOTE 5	$f = 66.7\text{MHz}$			6	ns
t_{DIS}	Output Disable Time; NOTE 5	$f = 66.7\text{MHz}$			6	ns

All parameters measured at 167MHz unless noted otherwise.

NOTE 1: Measured from the differential input crossing point to the output at $V_{DDO}/2$.

NOTE 2: Defined as skew within a bank of outputs at the same voltages and with equal load conditions.

NOTE 3: Defined as skew between outputs at the same supply voltage and with equal load conditions.

NOTE 4: Defined as the skew between outputs on different devices operating at the same supply voltages and with equal load conditions. Using the same type of inputs on each device, the outputs are measured at $V_{DDO}/2$.

NOTE 5: These parameters are guaranteed by characterization. Not tested in production.

NOTE 6: This parameter is defined in accordance with JEDEC Standard 65.

TABLE 4G. POWER SUPPLY DC CHARACTERISTICS, $V_{DD} = V_{DDO} = 2.5V \pm 5\%$, $T_A = 0^\circ C$ TO $70^\circ C$

Symbol	Parameter	Test Conditions	Minimum	Typical	Maximum	Units
V_{DD}	Positive Supply Voltage		2.375	2.5	2.625	V
V_{DDO}	Output Supply Voltage		2.375	2.5	2.625	V
I_{DD}	Positive Supply Current				120	mA

TABLE 4H. LVCMOS DC CHARACTERISTICS, $V_{DD} = V_{DDO} = 2.5V \pm 5\%$, $T_A = 0^\circ C$ TO $70^\circ C$

Symbol	Parameter	Test Conditions	Minimum	Typical	Maximum	Units
V_{IH}	Input High Voltage	CLK_SEL, OE1, OE2, OE3	2		$V_{DD} + 0.3$	V
V_{IL}	Input Low Voltage	CLK_SEL, OE1, OE2, OE3	-0.3		0.8	V
I_{IH}	Input High Current	OE1, OE2, OE3	$V_{DD} = V_{IN} = 2.625V$		5	μA
		CLK_SEL	$V_{DD} = V_{IN} = 2.625V$		150	μA
I_{IL}	Input Low Current	OE1, OE2, OE3	$V_{DD} = 2.625V, V_{IN} = 0V$	-150		μA
		CLK_SEL	$V_{DD} = 2.625V, V_{IN} = 0$	-5		μA
V_{OH}	Output High Voltage	$V_{DD} = V_{DDO} = 2.375V$ $I_{OH} = -27mA$	1.77			V
V_{OL}	Output Low Voltage	$V_{DD} = V_{DDO} = 2.375V$ $I_{OL} = 27mA$			0.6	V

TABLE 4I. DIFFERENTIAL DC CHARACTERISTICS, $V_{DD} = V_{DDO} = 2.5V \pm 5\%$, $T_A = 0^\circ C$ TO $70^\circ C$

Symbol	Parameter	Test Conditions	Minimum	Typical	Maximum	Units
I_{IH}	Input High Current	nCLK0, nCLK1			5	μA
		CLK0, CLK1			150	μA
I_{IL}	Input Low Current	nCLK0, nCLK1		-150		μA
		CLK0, CLK1		-5		μA
V_{PP}	Peak-to-Peak Input Voltage		0.3		1.3	V
V_{CMR}	Common Mode Input Voltage; Note 1, 2		GND + 0.5		$V_{DD} - 0.85$	V

NOTE 1: Common mode voltage is defined as V_{IH} .NOTE 2: For single ended applications, the maximum input voltage for CLKx, nCLKx is $V_{DD} + 0.3V$.

TABLE 5C. AC CHARACTERISTICS, $V_{DD} = V_{DDO} = 2.5V \pm 5\%$, $T_A = 0^\circ C$ TO $70^\circ C$

Symbol	Parameter	Test Conditions	Minimum	Typical	Maximum	Units
f_{MAX}	Output Frequency				167	MHz
t_{pLH}	Propagation Delay Low-to-High; NOTE 1	$f \leq 167\text{MHz}$	2.7		4.3	ns
t_{pHL}	Propagation Delay High-to-Low; NOTE 1	$f \leq 167\text{MHz}$	2.7		4.3	ns
$tsk(b)$	Bank Skew; NOTE 2, 6	Measured on the rising edge of $V_{DDO}/2$			150	ps
$tsk(o)$	Output Skew; NOTE 3, 6	Measured on the rising edge of $V_{DDO}/2$			275	ps
$tsk(pp)$	Part-to-Part Skew; NOTE 4, 6	Measured on the rising edge of $V_{DDO}/2$			600	ps
t_R	Output Rise Time; NOTE 5	30% to 70%	300		1700	ps
t_F	Output Fall Time; NOTE 5	30% to 70%	300		1400	ps
t_{PW}	Output Pulse Width	$f \leq 167\text{MHz}$	tPeriod/2 - 0.65	tPeriod/2	tPeriod/2 + 0.65	ns
		$f = 167\text{MHz}$	2.35		3.65	ns
t_{EN}	Output Enable Time; NOTE 5	$f = 66.7\text{MHz}$			6	ns
t_{DIS}	Output Disable Time; NOTE 5	$f = 66.7\text{MHz}$			6	ns

All parameters measured at 167MHz unless noted otherwise.

NOTE 1: Measured from the differential input crossing point to the output at $V_{DDO}/2$.

NOTE 2: Defined as skew within a bank of outputs at the same voltages and with equal load conditions.

NOTE 3: Defined as skew between outputs at the same supply voltage and with equal load conditions.

NOTE 4: Defined as the skew between outputs on different devices operating at the same supply voltages and with equal load conditions. Using the same type of inputs on each device, the outputs are measured at $V_{DDO}/2$.

NOTE 5: These parameters are guaranteed by characterization. Not tested in production.

NOTE 6: This parameter is defined in accordance with JEDEC Standard 65.

PARAMETER MEASUREMENT INFORMATION

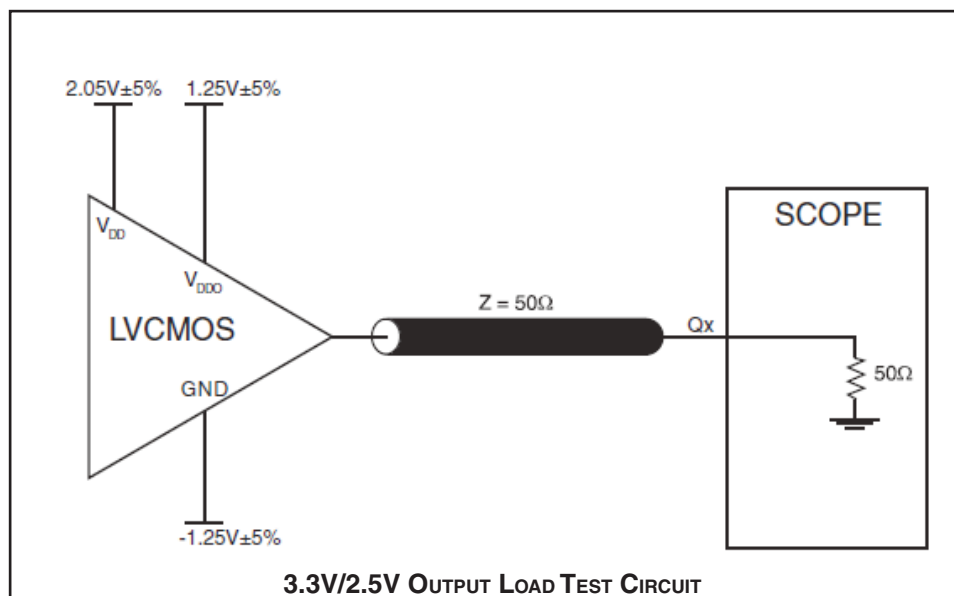
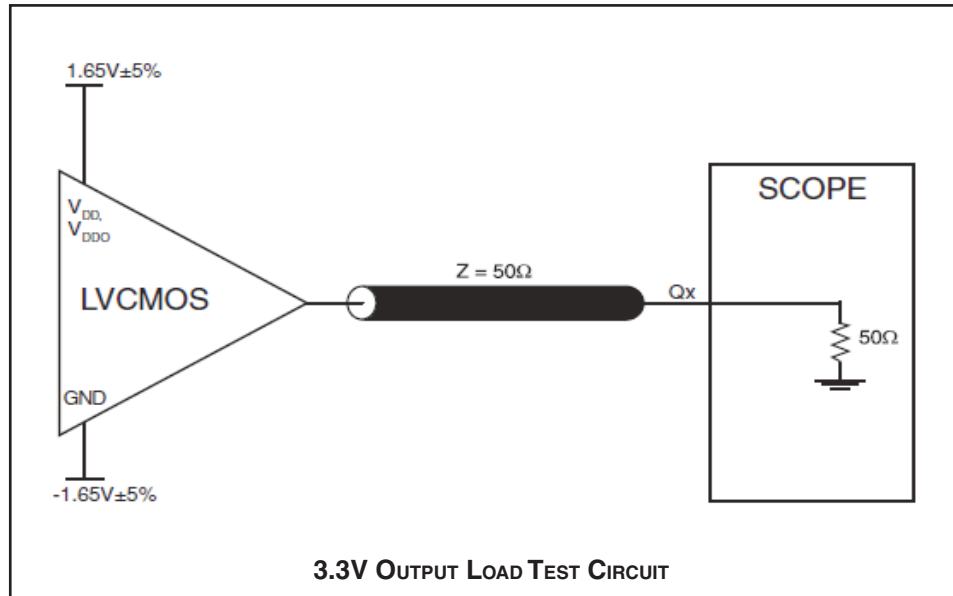

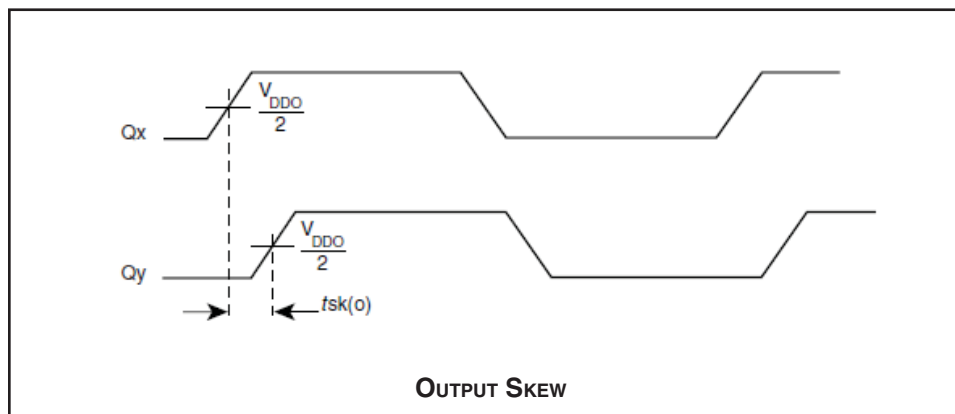
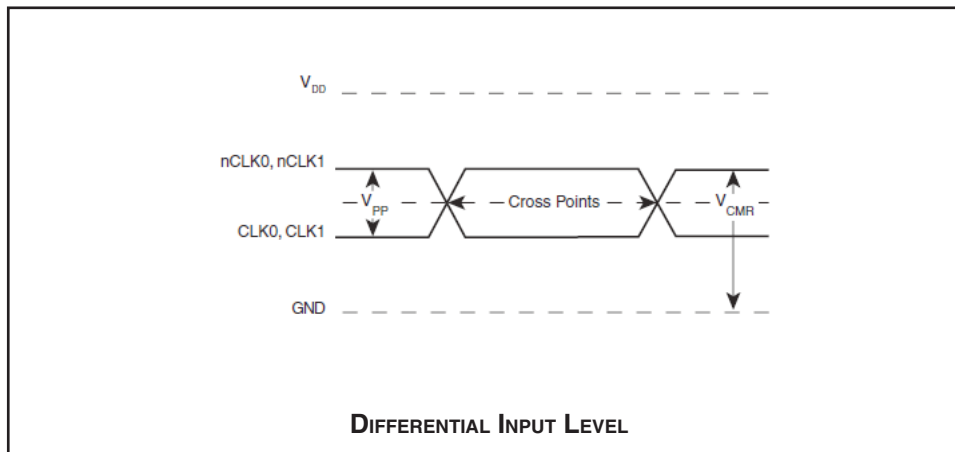
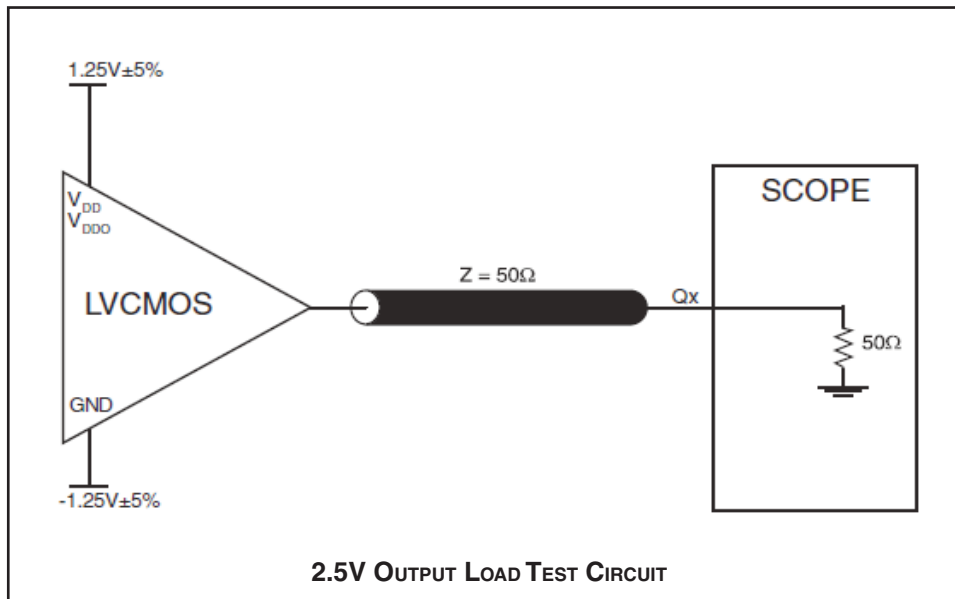

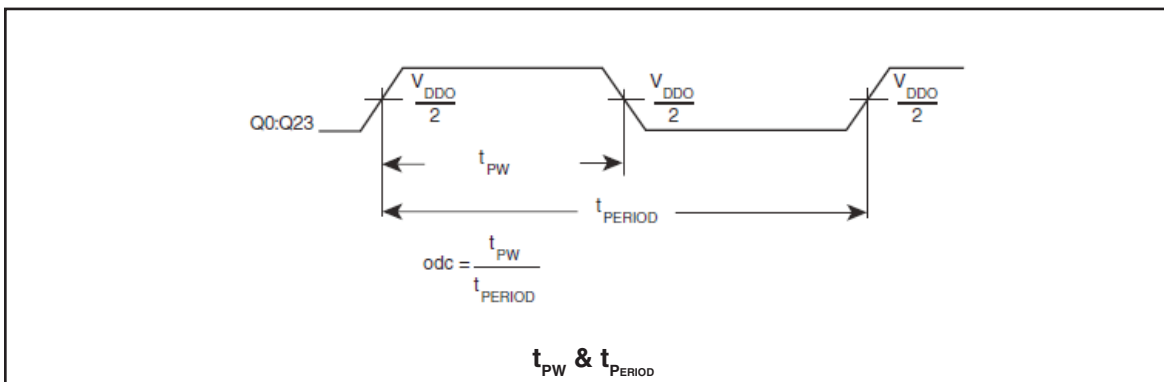
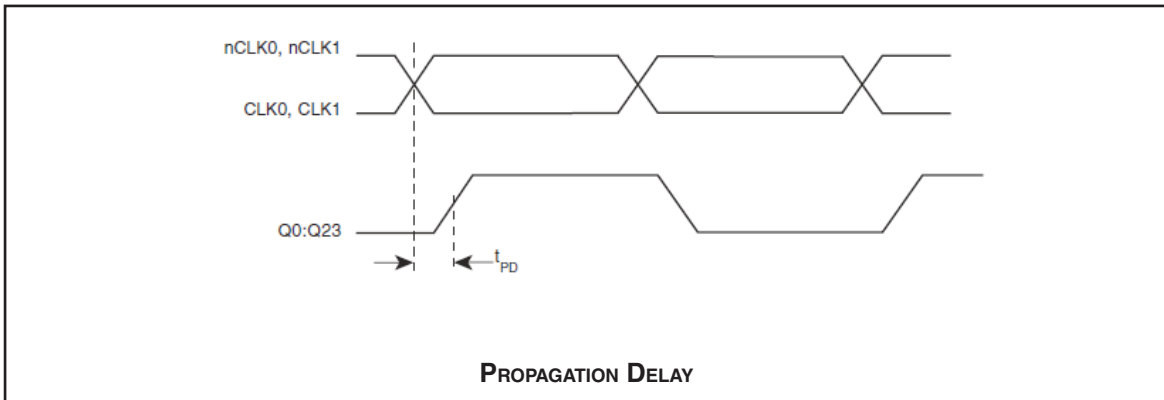
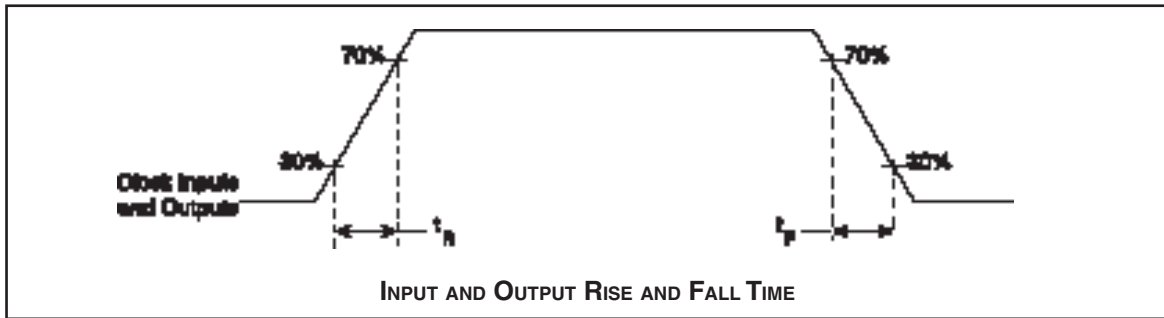
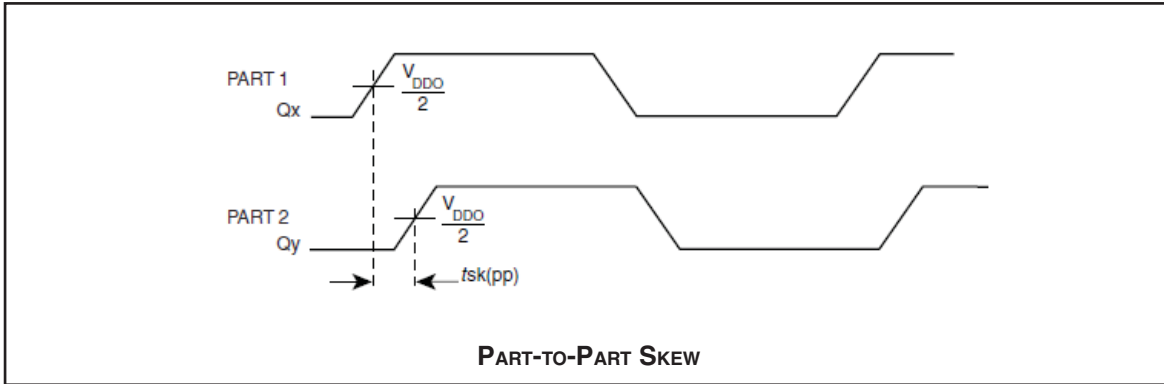

APPLICATION INFORMATION

WIRING THE DIFFERENTIAL INPUT TO ACCEPT SINGLE ENDED LEVELS

Figure 1 shows how the differential input can be wired to accept single ended levels. The reference voltage $V_{REF} = V_{DD}/2$ is generated by the bias resistors R1, R2 and C1. This bias circuit should be located as close as possible to the input pin. The ratio of R1 and R2 might need to be adjusted to position the V_{REF} in the center of the input voltage swing. For example, if the input clock swing is only 2.5V and $V_{DD} = 3.3V$, V_{REF} should be 1.25V and $R2/R1 = 0.609$.

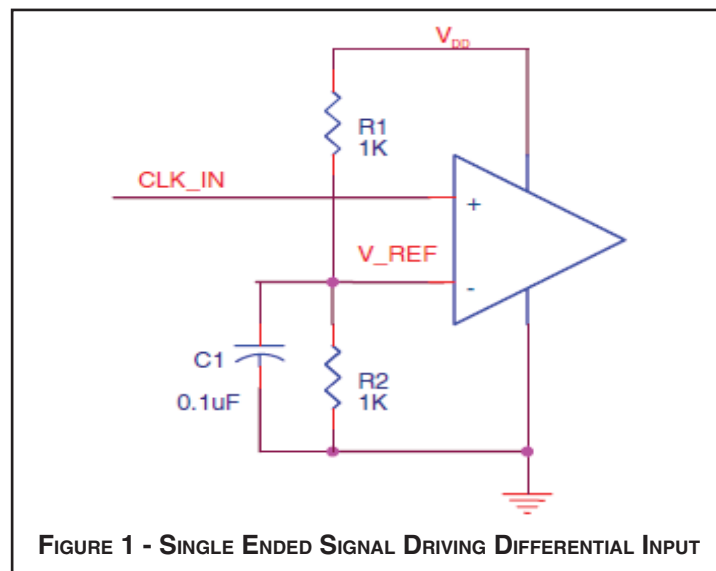

RELIABILITY INFORMATION

TABLE 6. θ_{JA} vs. AIR FLOW TABLE

θ_{JA} by Velocity (Linear Feet per Minute)			
	0	200	500
Single-Layer PCB, JEDEC Standard Test Boards	67.8°C/W	55.9°C/W	50.1°C/W
Multi-Layer PCB, JEDEC Standard Test Boards	47.9°C/W	42.1°C/W	39.4°C/W
NOTE: For 48-pin LQFP			

TRANSISTOR COUNT

The transistor count for 8344 is: 1449

PACKAGE OUTLINE - Y SUFFIX

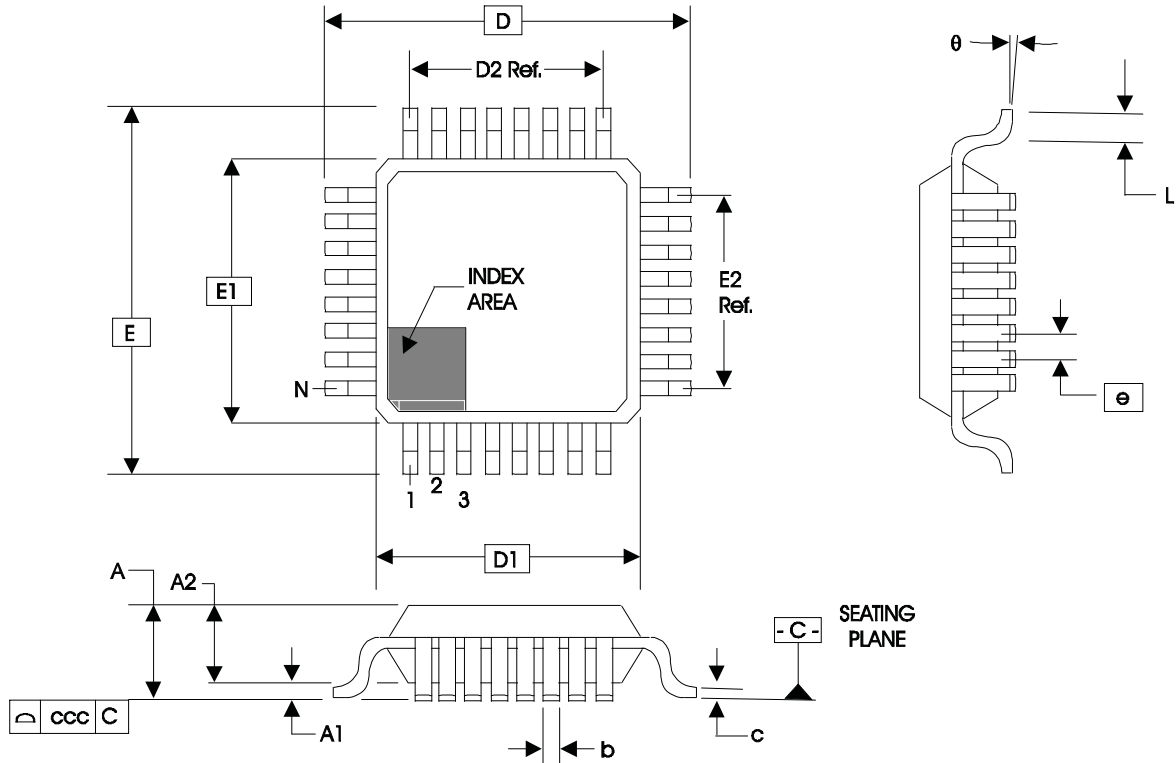

TABLE 7. PACKAGE DIMENSIONS

JEDEC VARIATION ALL DIMENSIONS IN MILLIMETERS			
SYMBOL	BBC		
	MINIMUM	NOMINAL	MAXIMUM
N	48		
A	--	--	1.60
A1	0.05	--	0.15
A2	1.35	1.40	1.45
b	0.17	0.22	0.27
c	0.09	--	0.20
D	9.00 BASIC		
D1	7.00 BASIC		
D2	5.50 Ref.		
E	9.00 BASIC		
E1	7.00 BASIC		
E2	5.50 Ref.		
e	0.50 BASIC		
L	0.45	0.60	0.75
θ	0°	--	7°
ccc	--	--	0.08

Reference Document: JEDEC Publication 95, MS-026

TABLE 8. ORDERING INFORMATION

Part/Order Number	Marking	Package	Shipping Packaging	Temperature
8344BYLF	ICS8344BYLF	Lead-Free, 48 Lead LQFP	Tray	0°C to 70°C
8344BYLFT	ICS8344BYLF	Lead-Free, 48 Lead LQFP	Tape and Reel	0°C to 70°C

NOTE: Parts that are ordered with an "LF" suffix to the part number are the Pb-Free configuration and are RoHS compliant.

REVISION HISTORY SHEET				
Rev	Table	Page	Description of Change	Date
A	T8	1 16	Features Section - added lead-free bullet. Ordering Information Table - deleted "ICS" prefix from Part/Order column. Added lead-free marking. Updated Header/Footer with IDT.	1/5/11
A	T8	15	Ordering Information - removed leaded devices. Updated Datasheet format.	3/24/15

**Corporate Headquarters**

6024 Silver Creek Valley Road
San Jose, California 95138

Sales

800-345-7015 or +408-284-8200
Fax: 408-284-2775
www.IDT.com

Technical Support

email: clocks@idt.com

DISCLAIMER Integrated Device Technology, Inc. (IDT) and its subsidiaries reserve the right to modify the products and/or specifications described herein at any time and at IDT's sole discretion. All information in this document, including descriptions of product features and performance, is subject to change without notice. Performance specifications and the operating parameters of the described products are determined in the independent state and are not guaranteed to perform the same way when installed in customer products. The information contained herein is provided without representation or warranty of any kind, whether express or implied, including, but not limited to, the suitability of IDT's products for any particular purpose, an implied warranty of merchantability, or non-infringement of the intellectual property rights of others. This document is presented only as a guide and does not convey any license under intellectual property rights of IDT or any third parties.

IDT's products are not intended for use in applications involving extreme environmental conditions or in life support systems or similar devices where the failure or malfunction of an IDT product can be reasonably expected to significantly affect the health or safety of users. Anyone using an IDT product in such a manner does so at their own risk, absent an express, written agreement by IDT.

Integrated Device Technology, IDT and the IDT logo are registered trademarks of IDT. Other trademarks and service marks used herein, including protected names, logos and designs, are the property of IDT or their respective third party owners.

Copyright 2015. All rights reserved.

IMPORTANT NOTICE AND DISCLAIMER

RENESAS ELECTRONICS CORPORATION AND ITS SUBSIDIARIES (“RENESAS”) PROVIDES TECHNICAL SPECIFICATIONS AND RELIABILITY DATA (INCLUDING DATASHEETS), DESIGN RESOURCES (INCLUDING REFERENCE DESIGNS), APPLICATION OR OTHER DESIGN ADVICE, WEB TOOLS, SAFETY INFORMATION, AND OTHER RESOURCES “AS IS” AND WITH ALL FAULTS, AND DISCLAIMS ALL WARRANTIES, EXPRESS OR IMPLIED, INCLUDING, WITHOUT LIMITATION, ANY IMPLIED WARRANTIES OF MERCHANTABILITY, FITNESS FOR A PARTICULAR PURPOSE, OR NON-INFRINGEMENT OF THIRD-PARTY INTELLECTUAL PROPERTY RIGHTS.

These resources are intended for developers who are designing with Renesas products. You are solely responsible for (1) selecting the appropriate products for your application, (2) designing, validating, and testing your application, and (3) ensuring your application meets applicable standards, and any other safety, security, or other requirements. These resources are subject to change without notice. Renesas grants you permission to use these resources only to develop an application that uses Renesas products. Other reproduction or use of these resources is strictly prohibited. No license is granted to any other Renesas intellectual property or to any third-party intellectual property. Renesas disclaims responsibility for, and you will fully indemnify Renesas and its representatives against, any claims, damages, costs, losses, or liabilities arising from your use of these resources. Renesas' products are provided only subject to Renesas' Terms and Conditions of Sale or other applicable terms agreed to in writing. No use of any Renesas resources expands or otherwise alters any applicable warranties or warranty disclaimers for these products.

(Disclaimer Rev.1.01)

Corporate Headquarters

TOYOSU FORESIA, 3-2-24 Toyosu,
Koto-ku, Tokyo 135-0061, Japan
www.renesas.com

Trademarks

Renesas and the Renesas logo are trademarks of Renesas Electronics Corporation. All trademarks and registered trademarks are the property of their respective owners.

Contact Information

For further information on a product, technology, the most up-to-date version of a document, or your nearest sales office, please visit www.renesas.com/contact-us/.