

General Description

The 840N022 is a LVCMOS/LVTTL clock synthesizer designed for Ethernet applications. The device generates a selectable 125MHz or 62.5MHz clock signal with excellent phase jitter performance. The device uses IDT's fourth generation FemtoClock® NG technology for an optimum of high clock frequency, low phase noise performance and low power consumption. The device supports 2.5V or 3.3V voltage supply and is packaged in a small, lead-free (RoHS 6) 8-lead TSSOP package. The extended temperature range supports wireless infrastructure, telecommunication, and networking end equipment requirements.

FREQ_SEL Frequency Table

Input FREQ_SEL	Output Frequency	
	$f_{XTAL} = 25\text{MHz}$	$f_{XTAL} = 20\text{MHz}$
0 (default)	125MHz	100MHz
1	62.5MHz	50MHz

NOTE: FREQ_SEL is an asynchronous control.

OE Function Table

Input OE	Output Enable
0	Output Q is disabled in high-impedance state
1 (default)	Output Q is enabled.

NOTE: OE is an asynchronous control.

Block Diagram

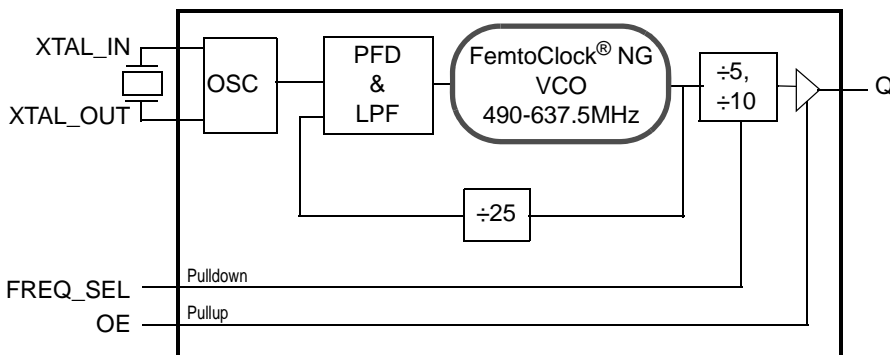

Features

- Fourth generation FemtoClock® NG technology
- 125MHz output clock synthesized from a 25MHz fundamental mode crystal
- One LVCMOS/LVTTL clock output
- Crystal interface designed for a 12pF parallel resonant crystal
- RMS phase jitter @ 125MHz, using a 25MHz crystal (1.875MHz - 20MHz): 0.148ps (maximum)
- RMS phase jitter @ 125MHz, using a 25MHz crystal (12kHz - 20MHz): 0.479ps (maximum)
- LVCMOS interface levels for the control inputs
- Full 2.5V or 3.3V supply voltage
- Lead-free (RoHS 6) packaging
- -40°C to 85°C ambient operating temperature
- **Use replacement part: 840N202CKI-dddLF**

Pin Assignment

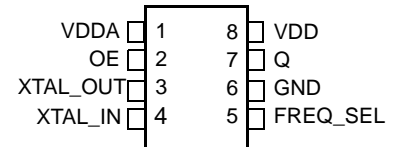

840N022
8-lead TSSOP
4.40mm x 3.0mm x 0.925mm
package body
G Package
Top View

Pin Descriptions and Characteristics

Table 1. Pin Descriptions

Number	Name	Type		Description
1	V _{DDA}	Power		Analog power supply.
2	OE	Input	Pullup	Output enable pin. LVCMOS interface levels.
3, 4	XTAL_OUT, XTAL_IN	Input		Crystal oscillator interface. XTAL_IN is the input, XTAL_OUT is the output.
5	FREQ_SEL	Input	Pulldown	Frequency select pin. LVCMOS interface levels.
6	GND	Power		Power supply ground.
7	Q	Output		Single-ended clock output. LVCMOS/LVTTL interface levels.
8	V _{DD}	Power		Core supply pin.

NOTE: *Pulldown* and *Pullup* refer to internal input resistors. See Table 2, *Pin Characteristics*, for typical values.

Table 2. Pin Characteristics

Symbol	Parameter	Test Conditions	Minimum	Typical	Maximum	Units
C _{IN}	Input Capacitance	OE, FREQ_SEL		3.5		pF
C _{PD}	Power Dissipation Capacitance	V _{DD} = 3.465V		11		pF
		V _{DD} = 2.625V		9		pF
R _{Pullup}	Input Pullup Resistor			51		kΩ
R _{Pulldown}	Input Pulldown Resistor			51		kΩ
R _{OUT}	Output Impedance	V _{DD} = 3.3V		15		Ω
		V _{DD} = 2.5V		19		Ω

Absolute Maximum Ratings

NOTE: Stresses beyond those listed under *Absolute Maximum Ratings* may cause permanent damage to the device. These ratings are stress specifications only. Functional operation of product at these conditions or any conditions beyond those listed in the *DC Characteristics* or *AC Characteristics* is not implied. Exposure to absolute maximum rating conditions for extended periods may affect product reliability.

Item	Rating
Supply Voltage, V_{DD}	3.63V
Inputs, V_I XTAL_IN Other Inputs	0V to 2V -0.5V to $V_{DD} + 0.5V$
Outputs, V_O	-0.5V to $V_{DD} + 0.5V$
Package Thermal Impedance, θ_{JA}	117°C/W (0 mps)
Storage Temperature, T_{STG}	-65°C to 150°C

DC Electrical Characteristics

Table 3A. Power Supply DC Characteristics, $V_{DD} = 3.3V \pm 5\%$ or $2.5V \pm 5\%$, $T_A = -40^\circ\text{C}$ to 85°C

Symbol	Parameter	Test Conditions	Minimum	Typical	Maximum	Units
V_{DD}	Core Supply Voltage		2.375	3.3	3.465	V
V_{DDA}	Analog Supply Voltage		$V_{DD} - 0.18$	3.3	V_{DD}	V
I_{DDA}	Analog Supply Current				18	mA
I_{DD}	Power Supply Current				67	mA

Table 3B. LVCMOS/LVTTL DC Characteristics, $V_{DD} = 3.3V \pm 5\%$ or $2.5V \pm 5\%$, $T_A = -40^\circ\text{C}$ to 85°C

Symbol	Parameter	Test Conditions	Minimum	Typical	Maximum	Units
V_{IH}	Input High Voltage	$V_{DD} = 3.3V$	2		$V_{DD} + 0.3$	V
		$V_{DD} = 2.5V$	1.7		$V_{DD} + 0.3$	V
V_{IL}	Input Low Voltage	OE $V_{DD} = 3.3V$	-0.3		0.8	V
		FREQ_SEL $V_{DD} = 3.3V$	-0.3		0.5	V
		OE $V_{DD} = 2.5V$	-0.3		0.7	V
		FREQ_SEL $V_{DD} = 2.5V$	-0.3		0.5	V
I_{IH}	Input High Current	OE $V_{DD} = V_{IN} = 3.465V$ or $2.625V$			5	μA
		FREQ_SEL $V_{DD} = V_{IN} = 3.465V$ or $2.625V$			150	μA
I_{IL}	Input Low Current	OE $V_{DD} = 3.465V$ or $2.625V$, $V_{IN} = 0V$	-150			μA
		FREQ_SEL $V_{DD} = 3.465V$ or $2.625V$, $V_{IN} = 0V$	-5			μA
V_{OH}	Output High Voltage; NOTE 1	Q $V_{DD} = 3.465V$	2.6			V
		Q $V_{DD} = 2.625V$	1.8			V
V_{OL}	Output Low Voltage; NOTE 1	Q $V_{DD} = 3.465V$ or $2.625V$			0.5	V

NOTE 1: Output terminated with 50Ω to $V_{DD} / 2$. See Parameter Measurement Information Section, *LVCMOS Output Load Test Circuit Diagrams*.

Table 4. Crystal Characteristics

Parameter	Test Conditions	Minimum	Typical	Maximum	Units
Mode of Oscillation		Fundamental			
Frequency		19.60	25	25.50	MHz
Equivalent Series Resistance (ESR)				80	Ω
Shunt Capacitance				7	pF
Capacitive Load (C_L)			12		pF

AC Characteristics

Table 5. AC Characteristics, $V_{DD} = 3.3V \pm 5\%$ or $2.5V \pm 5\%$, $T_A = -40^\circ\text{C}$ to 85°C

Symbol	Parameter	Test Conditions	Minimum	Typical	Maximum	Units
f_{OUT}	Output Frequency	FREQ_SEL = 0	98.00	125	127.50	MHz
		FREQ_SEL = 1	49.00	62.5	63.75	MHz
$f_{jit}(\emptyset)$	RMS Phase Jitter (Random); NOTE 1	$f_{OUT} = 125\text{MHz}$, 25MHz Crystal, Integration Range: 1.875MHz – 20MHz		0.104	0.148	ps
		$f_{OUT} = 125\text{MHz}$, 25MHz Crystal, Integration Range: 12kHz – 20MHz		0.286	0.479	ps
Φ_N	Single-Side Band Noise Power	125MHz, Offset: 10Hz		-51.7		dBc/Hz
		125MHz, Offset: 100Hz		-83.6		dBc/Hz
		125MHz, Offset: 1kHz		-115.9		dBc/Hz
		125MHz, Offset: 10kHz		-130.2		dBc/Hz
		125MHz, Offset: 100kHz		-134.7		dBc/Hz
		125MHz, Offset: 1MHz		-141.8		dBc/Hz
		125MHz, Offset: 10MHz		-158.3		dBc/Hz
t_R / t_F	Output Rise/Fall Time	20% to 80%	200		600	ps
odc	Output Duty Cycle		48		52	%

NOTE: Electrical parameters are guaranteed over the specified ambient operating temperature range, which is established when the device is mounted in a test socket with maintained transverse airflow greater than 500 lfm. The device will meet specifications after thermal equilibrium has been reached under these conditions.

NOTE: Characterized with 20MHz and 25MHz crystals.

NOTE 1: Please refer to the phase noise plots.

Typical Phase Noise at 125MHz

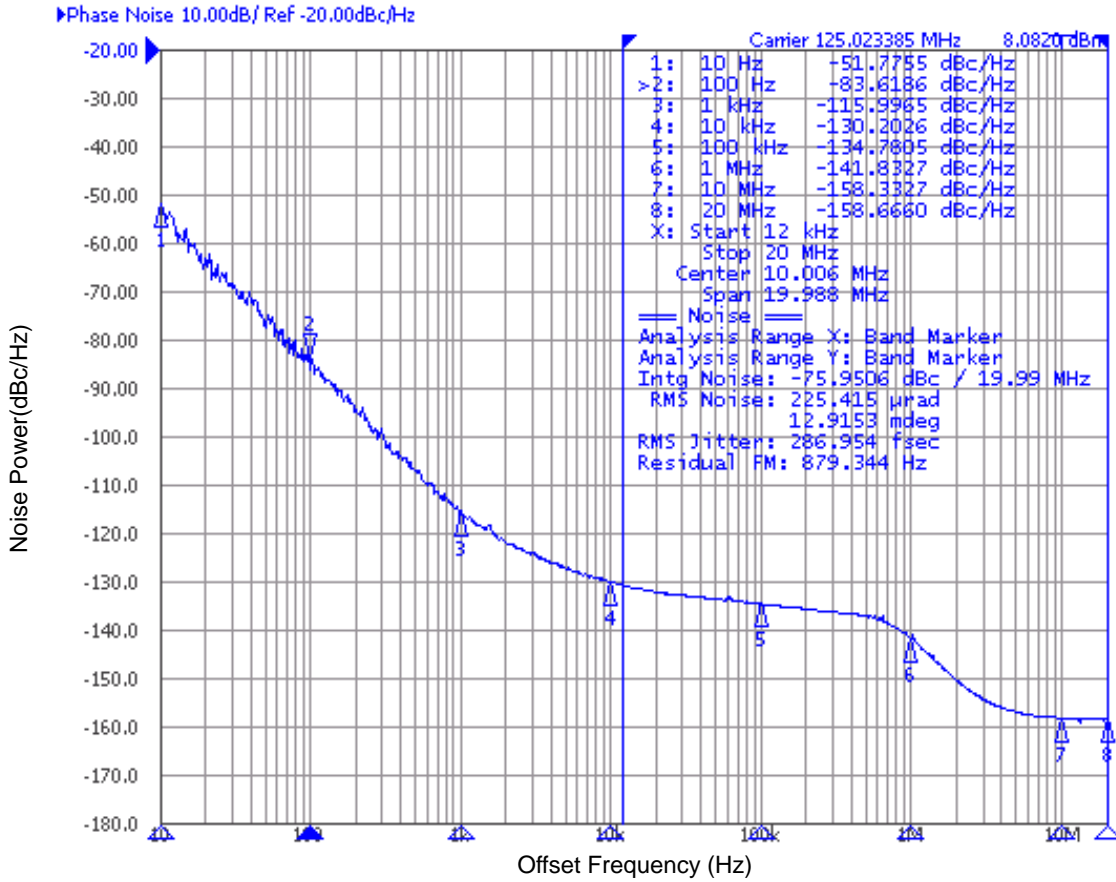

Typical Phase Noise at 125MHz

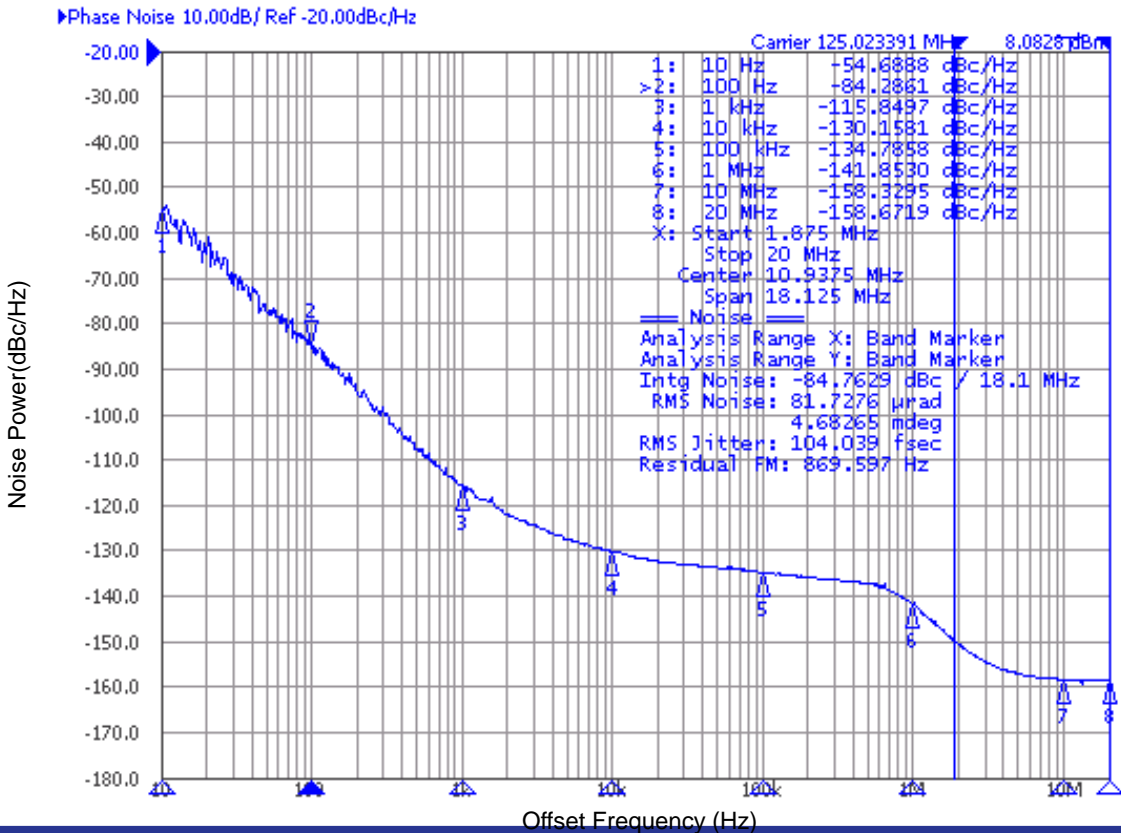

Parameter Measurement Information

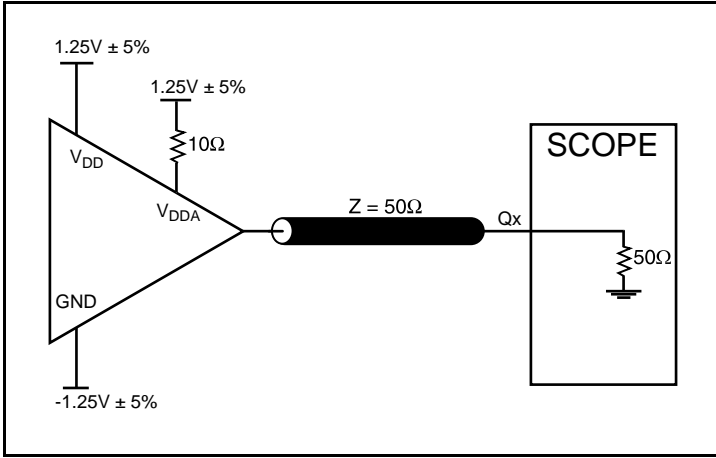

2.5V LVCMOS/LVTTL Output Load Test Circuit

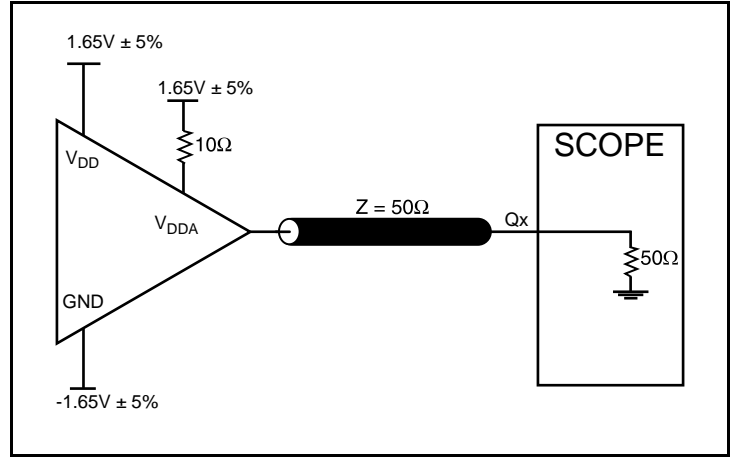

3.3V LVCMOS/LVTTL Output Load Test Circuit

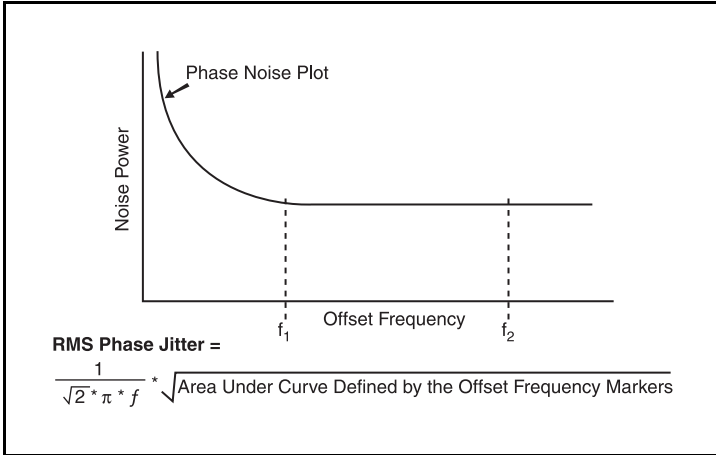

RMS Phase Jitter

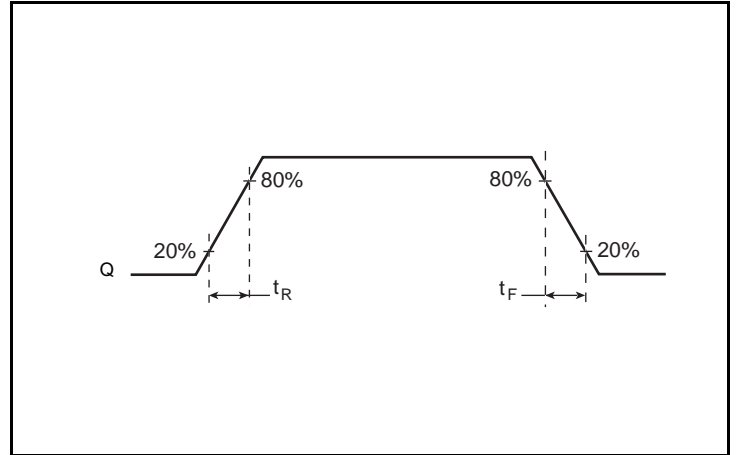

Output Rise/Fall Time

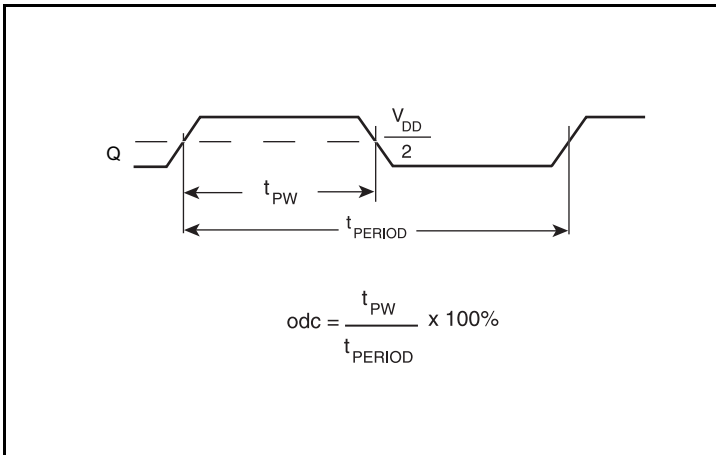

Output Duty Cycle/Pulse Width/Period

Applications Information

Overdriving the XTAL Interface

The XTAL_IN input can be overdriven by an LVCMOS driver or by one side of a differential driver through an AC coupling capacitor. The XTAL_OUT pin can be left floating. The amplitude of the input signal should be between 500mV and 1.8V and the slew rate should not be less than 0.2V/ns. For 3.3V LVCMOS inputs, the amplitude must be reduced from full swing to at least half the swing in order to prevent signal interference with the power rail and to reduce internal noise. *Figure 1A* shows an example of the interface diagram for a high speed 3.3V LVCMOS driver. This configuration requires that the sum of the output impedance of the driver (R_o) and the series resistance (R_s) equals the transmission line impedance. In addition, matched termination at the crystal input will attenuate the signal in half. This

can be done in one of two ways. First, R_1 and R_2 in parallel should equal the transmission line impedance. For most 50Ω applications, R_1 and R_2 can be 100Ω. This can also be accomplished by removing R_1 and changing R_2 to 50Ω. The values of the resistors can be increased to reduce the loading for a slower and weaker LVCMOS driver. *Figure 1B* shows an example of the interface diagram for an LVPECL driver. This is a standard LVPECL termination with one side of the driver feeding the XTAL_IN input. It is recommended that all components in the schematics be placed in the layout. Though some components might not be used, they can be utilized for debugging purposes. The datasheet specifications are characterized and guaranteed by using a quartz crystal as the input.

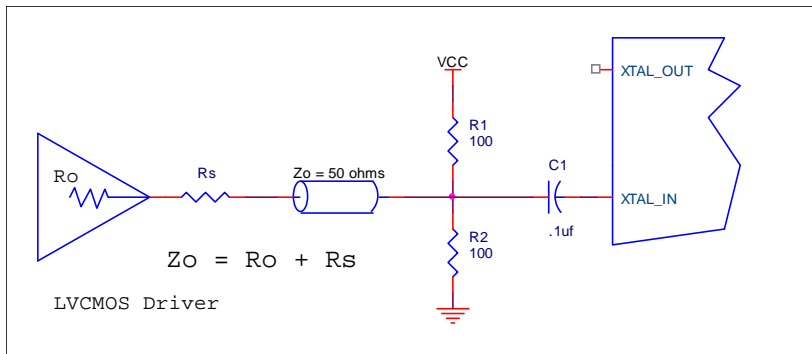

Figure 1A. General Diagram for LVCMOS Driver to XTAL Input Interface

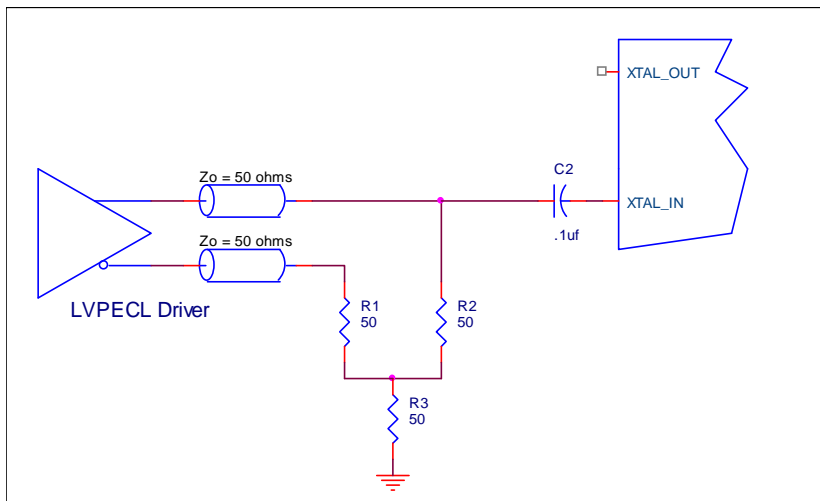

Figure 1B. General Diagram for LVPECL Driver to XTAL Input Interface

Schematic Example

Figure 2 shows an example 840N022 application schematic in which the device is operated at $V_{DD} = +3.3V$. The schematic example focuses on functional connections and is intended as an example only and may not represent the exact user configuration. Refer to the pin description and functional tables in the datasheet to ensure the logic control inputs are properly set. For example OE and FREQ_SEL can be configured from an FPGA instead of set with pull-up and pulldown resistors as shown

The crystal is to be laid out on the 840N022 side of the board and close to XTAL_IN and XTAL_OUT pins. Tuning capacitors C1 and C2 can be fine tuned to center the oscillator center frequency.

As with any high speed analog circuitry, the power supply pins are vulnerable to random noise, so to achieve optimum jitter performance isolation of the V_{DD} pin from power supply is required. In order to achieve the best possible filtering, it is recommended that the

placement of the filter components be on the device side of the PCB as close to the power pins as possible. If space is limited, the $0.1\mu F$ capacitors on the V_{DD} and V_{DDA} pins must be placed on the device side with direct return to the ground plane through vias. The remaining filter components can be on the opposite side of the PCB.

Power supply filter component recommendations are a general guideline to be used for reducing external noise from coupling into the devices. The filter performance is designed for a wide range of noise frequencies. This low-pass filter starts to attenuate noise at approximately 10kHz. If a specific frequency noise component is known, such as switching power supplies frequencies, it is recommended that component values be adjusted and if required, additional filtering be added. Additionally, good general design practices for power plane voltage stability suggests adding bulk capacitance in the local area of all devices.

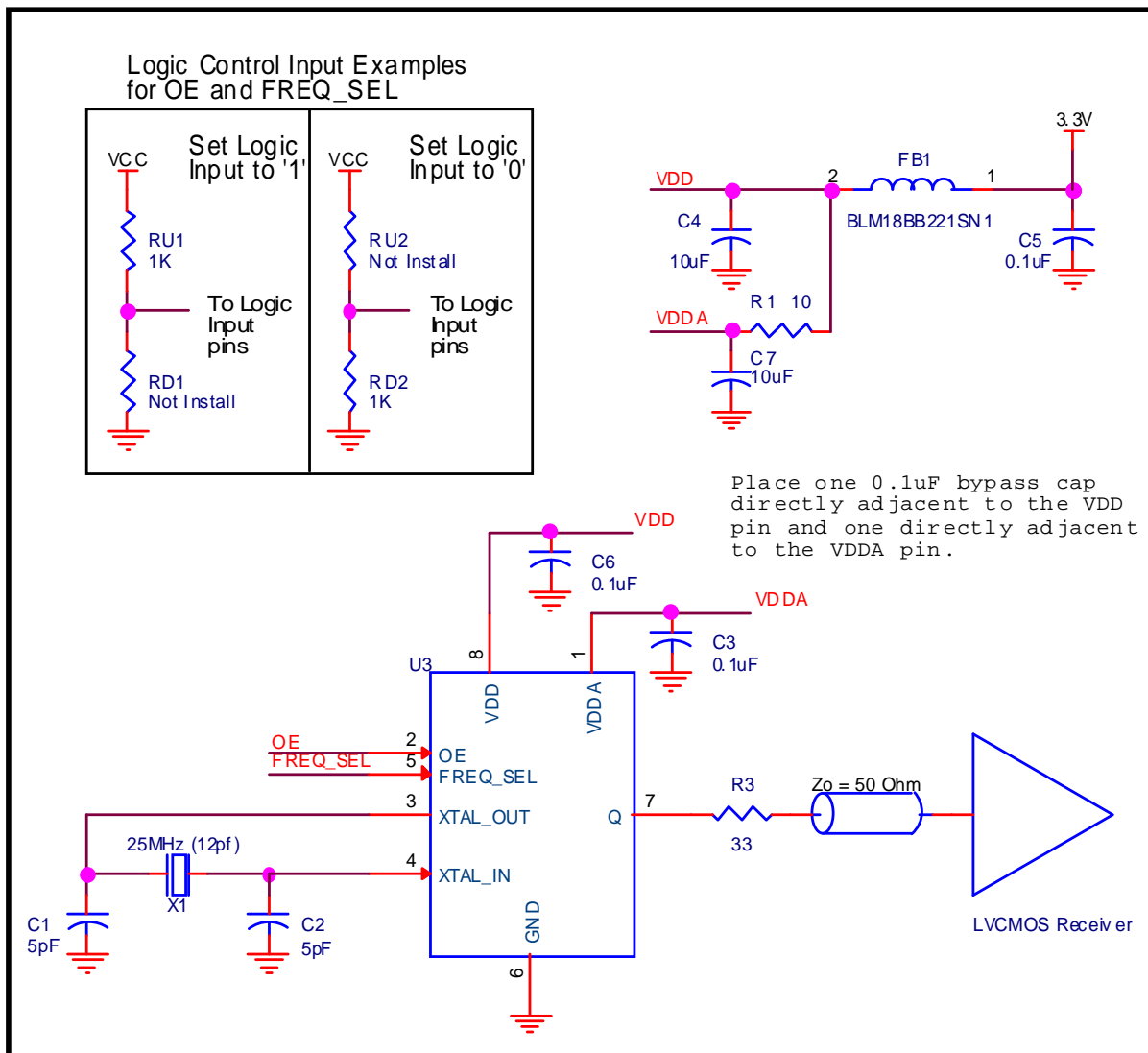

Figure 2. 840N022 Schematic Example

Power Considerations

This section provides information on power dissipation and junction temperature for the 840N022. Equations and example calculations are also provided.

1. Power Dissipation.

The total power dissipation for the 840N022 is the sum of the core power plus the analog power plus the power dissipated in the load(s). The following is the power dissipation for $V_{DD} = 3.3V + 5\% = 3.465V$, which gives worst case results.

- Power (core)_{MAX} = $V_{DD_MAX} * (I_{DD} + I_{DDA}) = 3.465V * (67mA + 18mA) = \mathbf{294.53mW}$
- Output Impedance R_{OUT} Current due to Loading 50Ω to $V_{DD}/2$
Output Current $I_{OUT} = V_{DD_MAX} / [2 * (50\Omega + R_{OUT})] = 3.465V / [2 * (50\Omega + 15\Omega)] = \mathbf{26.7mA}$
- Power Dissipation on the R_{OUT} per LVCMOS output
Power (R_{OUT}) = $R_{OUT} * (I_{OUT})^2 = 15\Omega * (26.7mA)^2 = \mathbf{10.7mW}$
- Total Power (R_{OUT}) = $10.7mW * 1 = \mathbf{10.7mW}$

Dynamic Power Dissipation at 125MHz

$$\text{Power (125MHz)} = C_{PD} * \text{Frequency} * (V_{DD})^2 = 11pF * 125MHz * (3.465V)^2 = \mathbf{16.51mW}$$

$$\text{Total Power (125MHz)} = 16.51mW * 1 = \mathbf{16.51mW}$$

Total Power Dissipation

- **Total Power**
= Power (core)_{MAX} + Power (R_{OUT}) + Power (125MHz)
= $294.53mW + 10.7mW + 16.51mW$
= $\mathbf{321.74mW}$

2. Junction Temperature.

Junction temperature, T_j , is the temperature at the junction of the bond wire and bond pad directly affects the reliability of the device. The maximum recommended junction temperature is 125°C . Limiting the internal transistor junction temperature, T_j , to 125°C ensures that the bond wire and bond pad temperature remains below 125°C .

$$\text{The equation for } T_j \text{ is as follows: } T_j = \theta_{JA} * Pd_{total} + T_A$$

T_j = Junction Temperature

θ_{JA} = Junction-to-Ambient Thermal Resistance

Pd_{total} = Total Device Power Dissipation (example calculation is in section 1 above)

T_A = Ambient Temperature

In order to calculate junction temperature, the appropriate junction-to-ambient thermal resistance θ_{JA} must be used. Assuming no air flow and a multi-layer board, the appropriate value is 117°C/W per Table 6 below.

Therefore, T_j for an ambient temperature of 85°C with all outputs switching is:

$$85^\circ\text{C} + 0.322W * 117^\circ\text{C/W} = 122.7^\circ\text{C}. \text{ This is below the limit of } 125^\circ\text{C}.$$

This calculation is only an example. T_j will obviously vary depending on the number of loaded outputs, supply voltage, air flow and the type of board (multi-layer).

Table 6. Thermal Resistance θ_{JA} for 8 Lead TSSOP, Forced Convection

θ_{JA} vs. Air Flow	
Meters per Second	0
Multi-Layer PCB, JEDEC Standard Test Boards	117°C/W

Reliability Information

Table 7. θ_{JA} vs. Air Flow Table for a 8-lead TSSOP

θ_{JA} vs. Air Flow	
Meters per Second	0
Multi-Layer PCB, JEDEC Standard Test Boards	117°C/W

Transistor Count

The transistor count for 840N022 is: 24,811

Package Outline and Package Dimensions

Package Outline - G Suffix for 8 Lead TSSOP

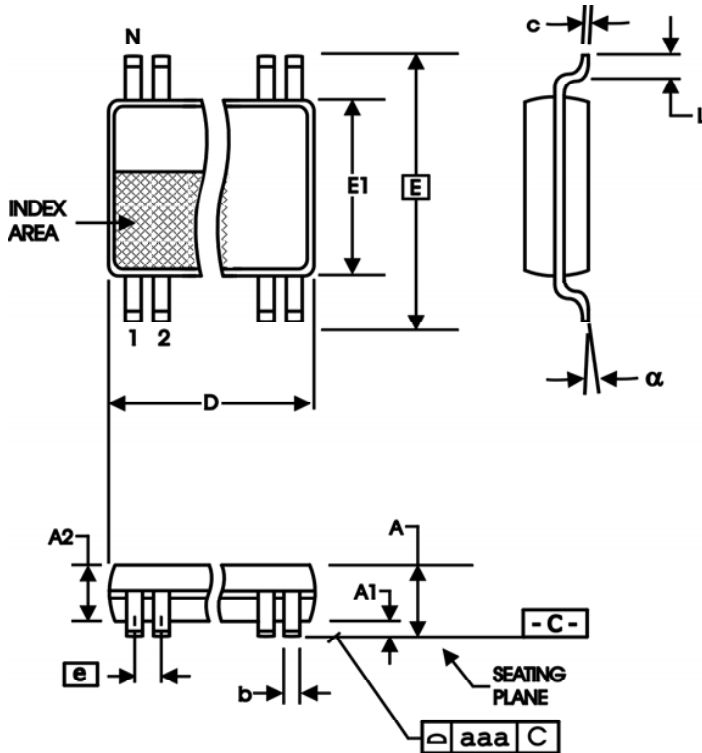

Table 8. Package Dimensions

All Dimensions in Millimeters		
Symbol	Minimum	Maximum
N	8	
A		1.20
A1	0.5	0.15
A2	0.80	1.05
b	0.19	0.30
c	0.09	0.20
D	2.90	3.10
E	6.40 Basic	
E1	4.30	4.50
e	0.65 Basic	
L	0.45	0.75
α	0°	8°
aaa	0.10	

Reference Document: JEDEC Publication 95, MO-153

Ordering Information

Table 9. Ordering Information

Part/Order Number	Marking	Package	Shipping Packaging	Temperature
840N022BGILF	22BIL	Lead-Free, 8-lead TSSOP	Tube	-40°C to 85°C
840N022BGILFT	22BIL	Lead-Free, 8-lead TSSOP	Tape & Reel	-40°C to 85°C

Revision History Sheet

Rev	Table	Page	Description of Change	Date
A			Product Discontinuation Notice - Last time buy expires August 14, 2016 PDN CQ-15-04	8/14/15

IMPORTANT NOTICE AND DISCLAIMER

RENESAS ELECTRONICS CORPORATION AND ITS SUBSIDIARIES (“RENESAS”) PROVIDES TECHNICAL SPECIFICATIONS AND RELIABILITY DATA (INCLUDING DATASHEETS), DESIGN RESOURCES (INCLUDING REFERENCE DESIGNS), APPLICATION OR OTHER DESIGN ADVICE, WEB TOOLS, SAFETY INFORMATION, AND OTHER RESOURCES “AS IS” AND WITH ALL FAULTS, AND DISCLAIMS ALL WARRANTIES, EXPRESS OR IMPLIED, INCLUDING, WITHOUT LIMITATION, ANY IMPLIED WARRANTIES OF MERCHANTABILITY, FITNESS FOR A PARTICULAR PURPOSE, OR NON-INFRINGEMENT OF THIRD-PARTY INTELLECTUAL PROPERTY RIGHTS.

These resources are intended for developers who are designing with Renesas products. You are solely responsible for (1) selecting the appropriate products for your application, (2) designing, validating, and testing your application, and (3) ensuring your application meets applicable standards, and any other safety, security, or other requirements. These resources are subject to change without notice. Renesas grants you permission to use these resources only to develop an application that uses Renesas products. Other reproduction or use of these resources is strictly prohibited. No license is granted to any other Renesas intellectual property or to any third-party intellectual property. Renesas disclaims responsibility for, and you will fully indemnify Renesas and its representatives against, any claims, damages, costs, losses, or liabilities arising from your use of these resources. Renesas' products are provided only subject to Renesas' Terms and Conditions of Sale or other applicable terms agreed to in writing. No use of any Renesas resources expands or otherwise alters any applicable warranties or warranty disclaimers for these products.

(Disclaimer Rev.1.01)

Corporate Headquarters

TOYOSU FORESIA, 3-2-24 Toyosu,
Koto-ku, Tokyo 135-0061, Japan
www.renesas.com

Trademarks

Renesas and the Renesas logo are trademarks of Renesas Electronics Corporation. All trademarks and registered trademarks are the property of their respective owners.

Contact Information

For further information on a product, technology, the most up-to-date version of a document, or your nearest sales office, please visit www.renesas.com/contact-us/.