

**843441-150 PRODUCT DISCONTINUATION NOTICE - LAST TIME BUY EXPIRES MAY 6, 2017**

**General Description**

The 843441 is a low jitter, high performance clock generator. The 843441 is designed for use in applications using the SAS and SATA interconnect. The 843441 uses an external, 25MHz, parallel resonant crystal to generate four selectable output frequencies: 75MHz, 100MHz, 150MHz, and 300MHz. This silicon based approach provides excellent frequency stability and reliability. The 843441 features down and center spread spectrum (SSC) clocking techniques.

**Additional Ordering Information**

Part/Order Number	Package	Output Frequency (MHz)
843441AG	16 TSSOP	75, 100, 150, 300
843441AM-75	8 SOIC	75
843441AM-100	8 SOIC	100
843441AM-150	8 SOIC	150
843441AM-300	8 SOIC	300

**Features**

- Designed for use in SAS, SAS-2, and SATA systems
- Center ( $\pm 0.33\%$ ) Spread Spectrum Clocking (SSC)
- Down ( $-0.30\%$  or  $-0.60\%$ ) SSC
- Better frequency stability than SAW oscillators
- One differential 3.3V LVPECL output
- Crystal oscillator interface designed for 25MHz ( $C_L = 18pF$ ) frequency
- External fundamental crystal frequency ensures high reliability and low aging
- Selectable output frequencies: 75MHz, 100MHz, 150MHz, 300MHz
- Output frequency is tunable with external capacitors
- RMS phase jitter: 1.33ps (typical)
- 3.3V operating supply
- 0°C to 70°C ambient operating temperature
- Industrial temperature available upon request
- Available in lead-free (RoHS 6) package
- **843441-150 Functional replacement part use 8T49N242i**

**Block Diagrams**

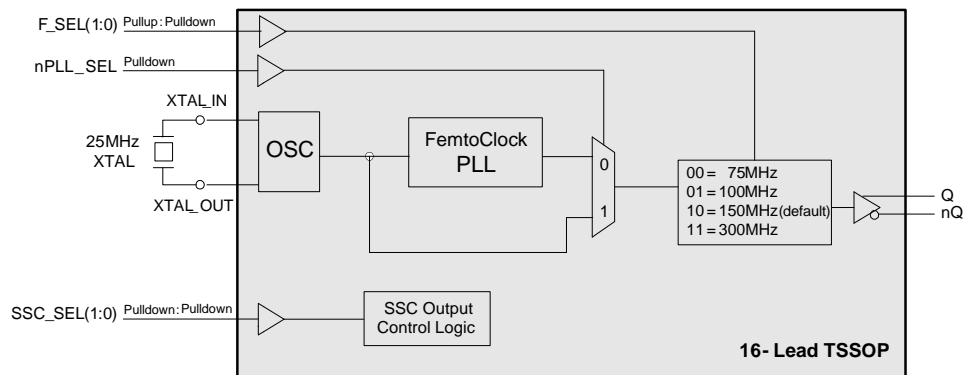
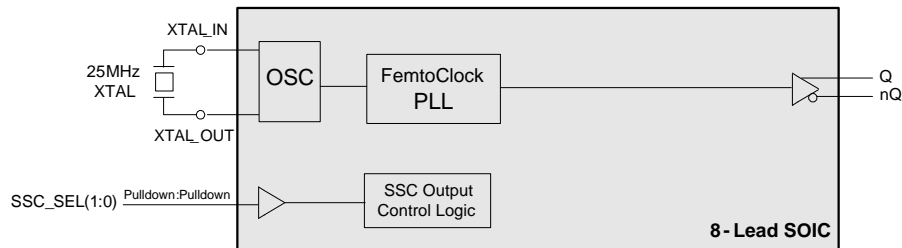

**Pin Assignments**



**843441**  
**8-Lead SOIC, 150 Mil**  
**3.90mm x 4.90mm x 1.375mm package body**  
**M Package**  
**Top View**

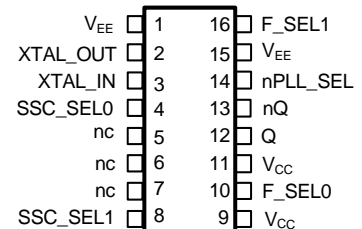

**843441**  
**16-Lead TSSOP**  
**4.4mm x 5.0mm x 0.925mm package body**  
**G Package**  
**Top View**

**Table 1A. Pin Descriptions (SOIC Package)**

Number	Name	Type		Description
1, 2	XTAL_OUT, XTAL_IN	Input	Pullup	Crystal oscillator interface. XTAL_IN is the input, XTAL_OUT is the output.
3, 4	SSC_SEL0, SSC_SEL1	Input	Pulldown	SSC select pins. See Table 3A. LVCMOS/LVTTL interface levels.
5	V <sub>CC</sub>	Power		Power supply pin.
6, 7	Q, nQ	Output		Differential clock outputs. LVPECL interface levels.
8	V <sub>EE</sub>	Power		Negative supply pin.

NOTE: Pullup/Pulldown refers to internal input resistors. See Table 2, *Pin Characteristics*, for typical values.

**Table 1B. Pin Descriptions (TSSOP Package)**

Number	Name	Type		Description
1, 15	V <sub>EE</sub>	Power		Negative supply pins.
2, 3	XTAL_OUT, XTAL_IN	Input	Pullup	Crystal oscillator interface. XTAL_IN is the input, XTAL_OUT is the output.
4, 8	SSC_SEL0, SSC_SEL1	Input	Pulldown	SSC select pins. See Table 3A. LVCMOS/LVTTL interface levels.
5, 6, 7	nc	Unused		No connect pins.
9, 11	V <sub>CC</sub>	Power		Power supply pins.
10	F_SEL0	Input	Pulldown	Output frequency select pin. See Table 3B. LVCMOS/LVTTL interface levels.
12, 13	Q, nQ	Output		Differential clock outputs. LVPECL interface levels.
14	nPLL_SEL	Input	Pulldown	PLL Bypass pin. LVCMOS/LVTTL interface levels.
16	F_SEL1	Input	Pullup	Output frequency select pin. See Table 3B. LVCMOS/LVTTL interface levels.

NOTE: Pullup/Pulldown refers to internal input resistors. See Table 2, *Pin Characteristics*, for typical values.

**Table 2. Pin Characteristics**

Symbol	Parameter	Test Conditions	Minimum	Typical	Maximum	Units
C <sub>IN</sub>	Input Capacitance			4		pF
R <sub>PULLDOWN</sub>	Input Pulldown Resistor			51		kΩ
R <sub>PULLUP</sub>	Input Pullup Resistor			51		kΩ

## Function Tables

**Table 3A. SSC\_SEL[1:0] Function Table**

Inputs		Mode
SSC_SEL1	SSC_SEL0	
0 (default)	0 (default)	SSC Off
0	1	0.60% Down-spread
1	0	0.30% Down-spread
1	1	0.33% Center-spread

**Table 3B. F\_SEL[1:0] Function Table**

Inputs		Output Frequency (MHz)
F_SEL1	F_SEL0	
0	0	75
0	1	100
1 (default)	0 (default)	150
1	1	300

Table 3B applicable only for 16 Lead TSSOP package.

## Absolute Maximum Ratings

NOTE: Stresses beyond those listed under *Absolute Maximum Ratings* may cause permanent damage to the device. These ratings are stress specifications only. Functional operation of product at these conditions or any conditions beyond those listed in the *DC Characteristics* or *AC Characteristics* is not implied. Exposure to absolute maximum rating conditions for extended periods may affect product reliability.

Item	Rating
Supply Voltage, $V_{CC}$	4.6V
Inputs, $V_I$ , (LVCMOS) XTAL_IN Other Inputs	0V to $V_{CC}$ -0.5V to $V_{CC} + 0.5V$
Outputs, $I_O$ Continuous Current Surge Current	50mA 100mA
Package Thermal Impedance, $\theta_{JA}$ 16 Lead TSSOP 8 Lead SOIC	81.2°C/W (0 mps) 96.0°C/W (0 lfpm)
Storage Temperature, $T_{STG}$	-65°C to 150°C

## DC Electrical Characteristics

**Table 4A. Power Supply DC Characteristics,  $V_{CC} = 3.3V \pm 5\%$ ,  $V_{EE} = 0V$ ,  $T_A = 0^\circ C$  to  $70^\circ C$**

Symbol	Parameter	Test Conditions	Minimum	Typical	Maximum	Units
$V_{CC}$	Power Supply Voltage		3.135	3.3	3.465	V
$I_{EE}$	Power Supply Current				66	mA

**Table 4B. LVCMOS/LVTTL DC Characteristics,  $V_{CC} = 3.3V \pm 5\%$ ,  $V_{EE} = 0V$ ,  $T_A = 0^\circ C$  to  $70^\circ C$**

Symbol	Parameter	Test Conditions	Minimum	Typical	Maximum	Units
$V_{IH}$	Input High Voltage		2		$V_{DD} + 0.3$	V
$V_{IL}$	Input Low Voltage		-0.3		0.8	V
$I_{IH}$	Input High Current	F_SEL1	$V_{CC} = V_{IN} = 3.465V$		5	$\mu A$
		SSC_SEL[0:1], F_SEL0, nPLL_SEL	$V_{CC} = V_{IN} = 3.465V$		150	$\mu A$
$I_{IL}$	Input Low Current	F_SEL1	$V_{CC} = 3.465V, V_{IN} = 0V$	-150		$\mu A$
		SSC_SEL[0:1], F_SEL0, nPLL_SEL	$V_{CC} = 3.465V, V_{IN} = 0V$	-5		$\mu A$

**Table 4C. LVPECL DC Characteristics,  $V_{CC} = 3.3V \pm 5\%$ ,  $V_{EE} = 0V$ ,  $T_A = 0^\circ C$  to  $70^\circ C$**

Symbol	Parameter	Test Conditions	Minimum	Typical	Maximum	Units
$V_{OH}$	Output High Voltage; NOTE 1		$V_{CC} - 1.4$		$V_{CC} - 0.9$	V
$V_{OL}$	Output Low Voltage; NOTE 1		$V_{CC} - 2.0$		$V_{CC} - 1.7$	V
$V_{SWING}$	Peak-to-Peak Output Voltage Swing		0.6		0.9	V

NOTE 1: Output termination with  $50\Omega$  to  $V_{CC} - 2V$ .

## AC Electrical Characteristics

**Table 5. AC Characteristics,  $V_{CC} = 3.3V \pm 5\%$ ,  $V_{EE} = 0V$ ,  $T_A = 0^\circ C$  to  $70^\circ C$**

Symbol	Parameter	Test Conditions	Minimum	Typical	Maximum	Units
$f_{OUT}$	Output Frequency	F_SEL(1:0) = 00		75		MHz
		F_SEL(1:0) = 01		100		MHz
		F_SEL(1:0) = 10		150		MHz
		F_SEL(1:0) = 11		300		MHz
$f_{jit}(\emptyset)$	RMS Phase Jitter (Random); NOTE 1	75MHz, Integration Range: 12kHz – 20 MHz		1.33		ps
		100MHz, Integration Range: 12kHz – 20MHz		1.39		ps
		150MHz, Integration Range: 12kHz – 20MHz		1.36		ps
		300MHz, Integration Range: 12kHz – 20MHz		1.37		ps
$f_{jit}(per)$	Period Jitter, RMS; NOTE 2, 3	75MHz, SSC Off		4.15		ps
		100MHz, SSC Off		4.05		ps
		150MHz, SSC Off		4.15		ps
		300MHz, SSC Off		4.25		ps
$f_{jit}(cc)$	Cycle-to-Cycle Jitter: NOTE 3	75MHz, SSC Off			31	ps
		100MHz, SSC Off			31	ps
		150MHz, SSC Off			31	ps
		300MHz, SSC Off			31	ps
$t_R / t_F$	Output Rise/Fall Time	20% to 80%	200		700	ps
odc	Output Duty Cycle		45		55	%

NOTE: Using a 25MHz, 18pF quartz crystal.

NOTE: Electrical parameters are guaranteed over the specified ambient operating temperature range, which is established when the device is mounted in a test socket with maintained transverse airflow greater than 500 lfm. The device will meet specifications after thermal equilibrium has been reached under these conditions.

NOTE 1: Please refer to the Phase Noise plots.

NOTE 2: Refer to Application Section for peak-to-peak jitter calculations.

NOTE 3: Tested per JEDEC 65B.

### Typical Phase Noise at 100MHz

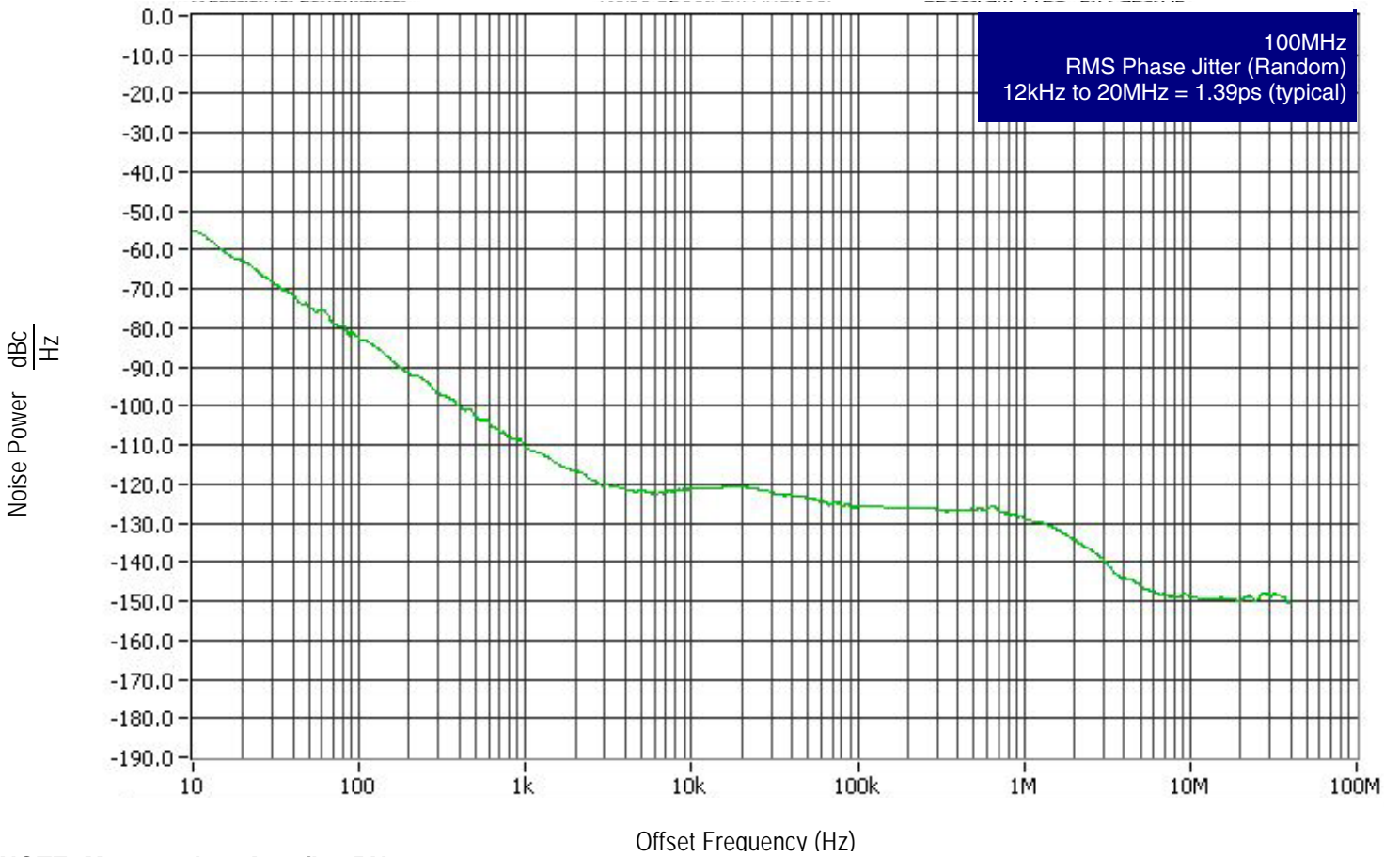

**NOTE: Measured on Aeroflex PN9000**

### Parameter Measurement Information

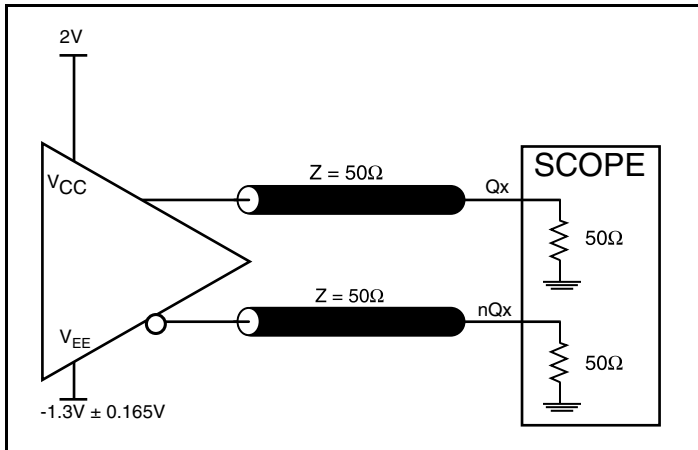

3.3V LVPECL Output Load AC Test Circuit

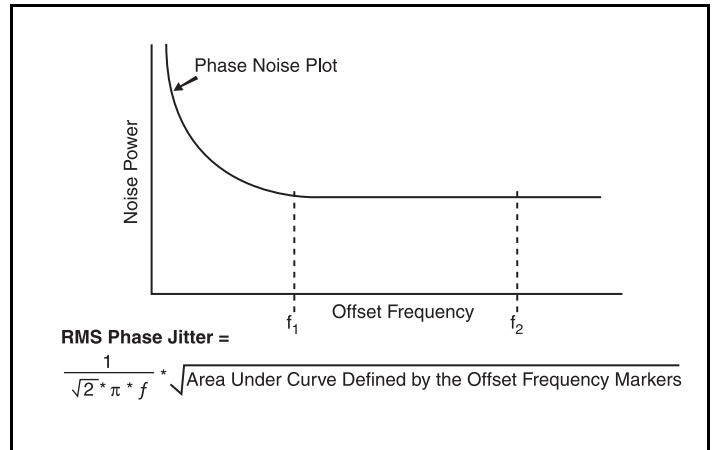

RMS Phase Jitter

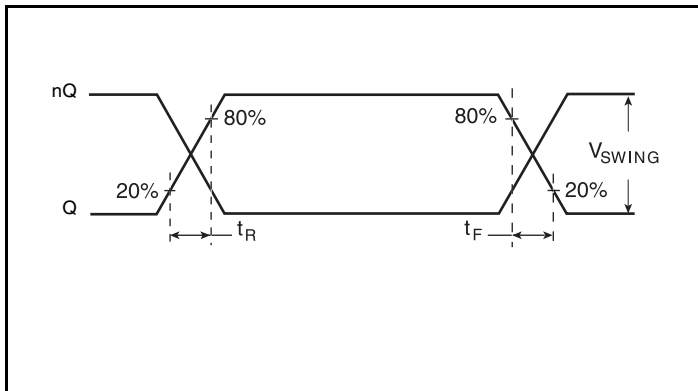

Output Rise/Fall Time

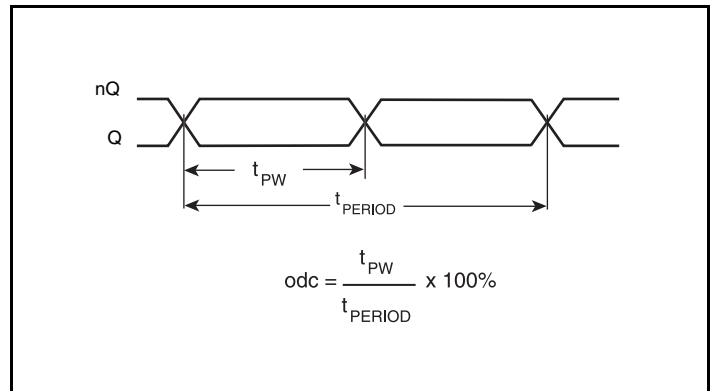

Output Duty Cycle/Pulse Width/Period

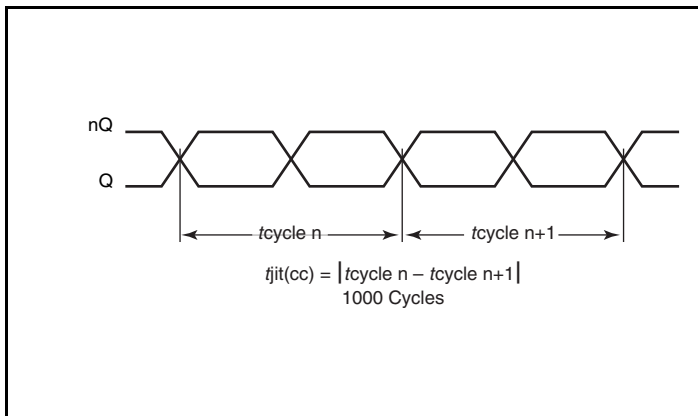

Cycle-to-Cycle Jitter

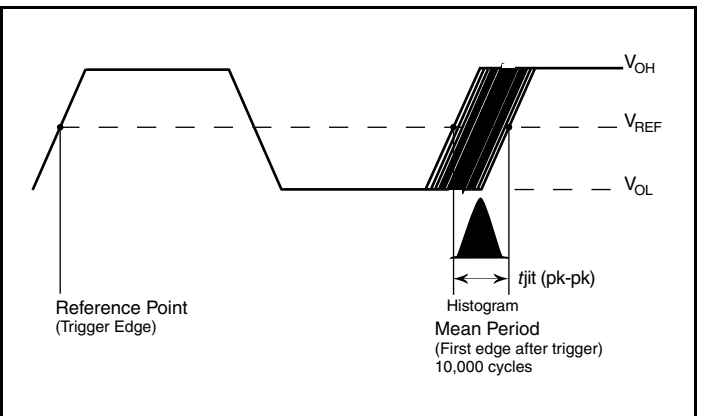

RMS Period Jitter, Peak-to-Peak

## Applications Information

### Recommendations for Unused Input Pins

#### Inputs:

##### LVC MOS Control Pins

All control pins have internal pullups and pulldowns; additional resistance is not required but can be added for additional protection. A 1kΩ resistor can be used.

### Overdriving the XTAL Interface

The XTAL\_IN input can accept a single-ended LVC MOS signal through an AC coupling capacitor. A general interface diagram is shown in *Figure 1A*. The XTAL\_OUT pin can be left floating. The maximum amplitude of the input signal should not exceed 2V and the input edge rate can be as slow as 10ns. This configuration requires that the output impedance of the driver ( $R_o$ ) plus the series resistance ( $R_s$ ) equals the transmission line impedance. In addition,

matched termination at the crystal input will attenuate the signal in half. This can be done in one of two ways. First,  $R_1$  and  $R_2$  in parallel should equal the transmission line impedance. For most 50Ω applications,  $R_1$  and  $R_2$  can be 100Ω. This can also be accomplished by removing  $R_1$  and making  $R_2$  50Ω. By overdriving the crystal oscillator, the device will be functional, but note, the device performance is guaranteed by using a quartz crystal.

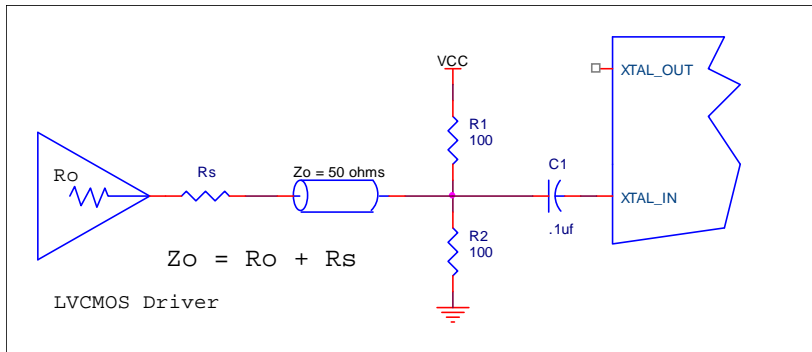
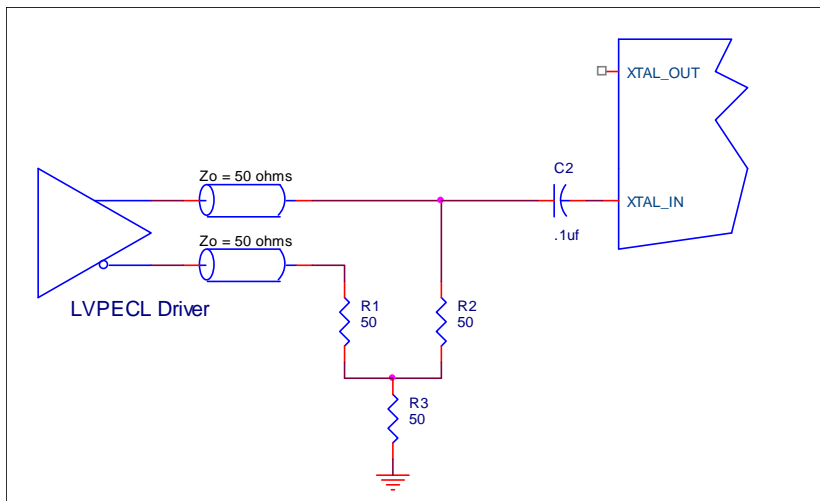

Figure 1A. General Diagram for LVC MOS Driver to XTAL Input Interface



**Figure 1B. General Diagram for LVPECL Driver to XTAL Input Interface**

**Termination for 3.3V LVPECL Outputs**

The clock layout topology shown below is a typical termination for LVPECL outputs. The two different layouts mentioned are recommended only as guidelines.

The differential outputs are low impedance follower outputs that generate ECL/LVPECL compatible outputs. Therefore, terminating resistors (DC current path to ground) or current sources must be used for functionality. These outputs are designed to drive 50Ω

transmission lines. Matched impedance techniques should be used to maximize operating frequency and minimize signal distortion.

Figures 2A and 2B show two different layouts which are recommended only as guidelines. Other suitable clock layouts may exist and it would be recommended that the board designers simulate to guarantee compatibility across all printed circuit and clock component process variations.

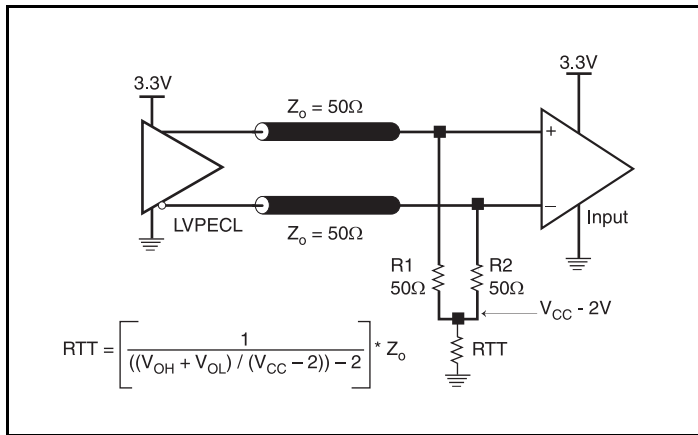

**Figure 2A. 3.3V LVPECL Output Termination**

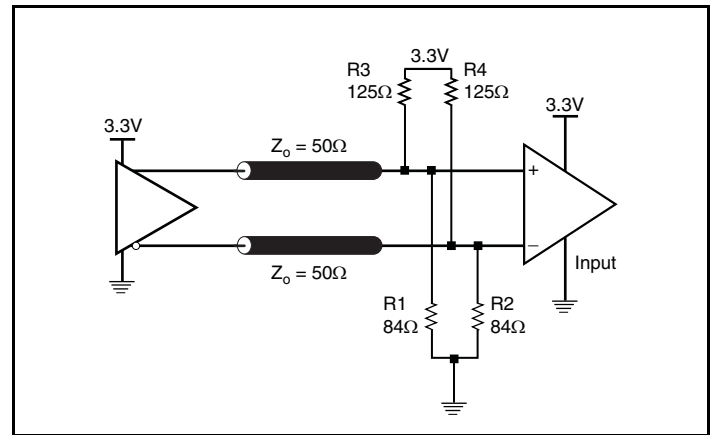

**Figure 2B. 3.3V LVPECL Output Termination**

### Schematic Example

Figure 3 shows an example of 843441 application schematic. In this example, the device is operated at  $V_{CC} = 3.3V$ . An 18pF parallel resonant 25MHz crystal is used. The load capacitance  $C1 = 27pF$  and  $C2 = 27pF$  are recommended for frequency accuracy. Depending on the parasitics of the printed circuit board layout, these values might require a slight adjustment to optimize the frequency accuracy. Crystals with other load capacitance specifications can be used. This will required adjusting C1 and C2.

As with any high speed analog circuitry, the power supply pins are vulnerable to random noise. To achieve optimum jitter performance, power supply isolation is required. The 843441 provides separate power supplies to isolate noise from coupling into the internal PLL. In order to achieve the best possible filtering, it is recommended that the placement of the filter components be on the device side of the PCB as close to the power pins as possible. If space is limited, the  $0.1\mu F$  capacitor in each power pin filter should be placed on the device side of the PCB and the other components can be placed on

the opposite side.

Power supply filter recommendations are a general guideline to be used for reducing external noise from coupling into the devices. The filter performance is designed for wide range of noise frequencies. This low-pass filter starts to attenuate noise at approximately 10kHz. If a specific frequency noise component is known, such as switching power supply frequencies, it is recommended that component values be adjusted and if required, additional filtering be added. Additionally, good general design practices for power plane voltage stability suggests adding bulk capacitances in the local area of all devices.

The schematic example focuses on functional connections and is not configuration specific. Refer to the pin description and functional tables in the datasheet to ensure the logic control inputs are properly set.

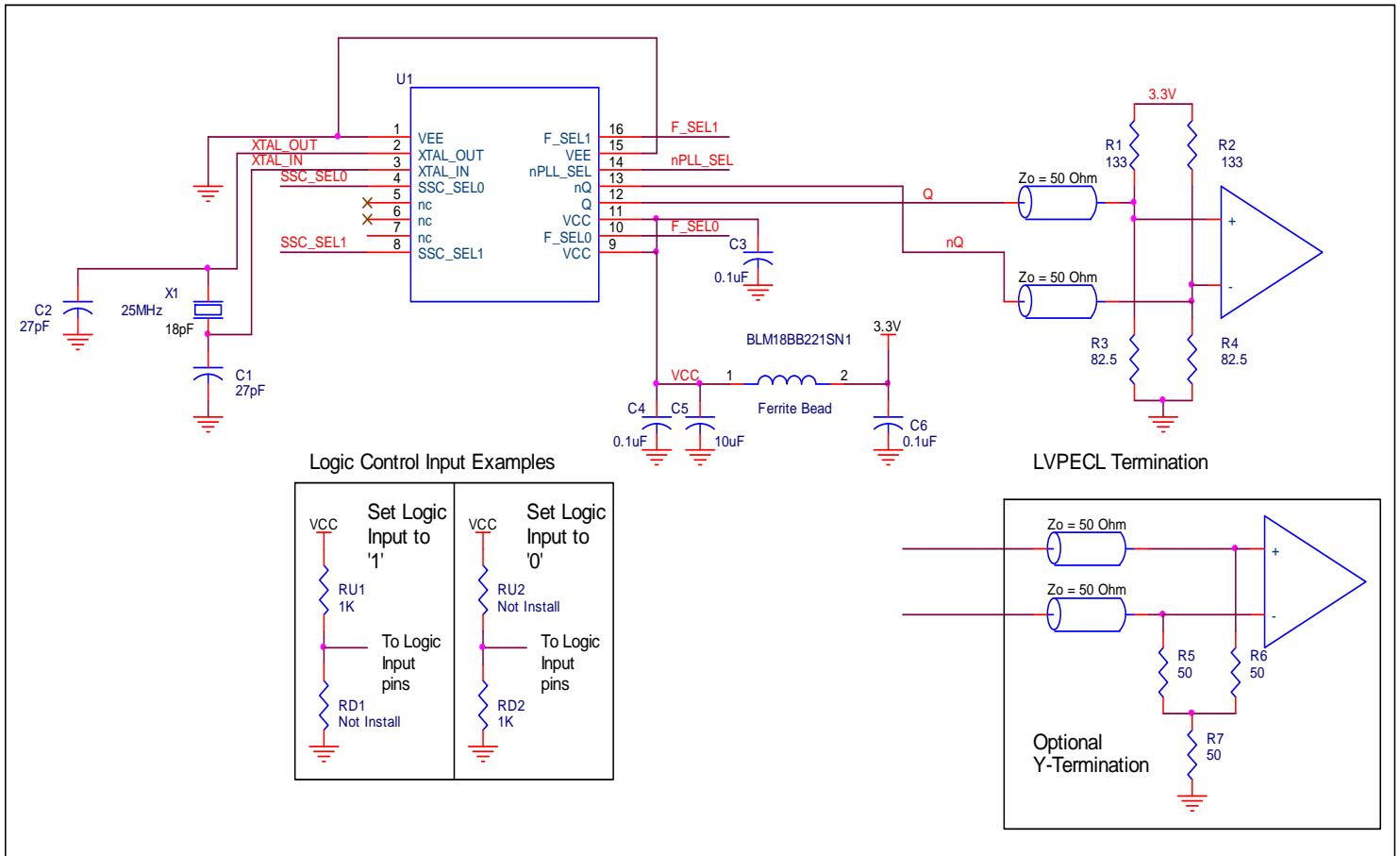

Figure 3. 843441 Schematic Example

## Peak-to-Peak Jitter Calculations

A standard deviation of a statistical population or data set is the square root of its variance. A standard deviation is used to calculate the probability of an anomaly or to predict a failure. Many times, the term "root mean square" (RMS) is used synonymously for standard deviation. This is accurate when referring to the square root of the mean squared deviation of a signal from a given baseline and the data set contains a Gaussian distribution with no deterministic components. A low standard deviation indicates that the data set tends to be close to the mean with little variation. A large standard deviation indicates that the data set is spread out and has a large variation from the mean.

A standard deviation is required when calculating peak-to-peak jitter. Since true peak-to-peak jitter is random and unbounded, it is important to always associate a bit error ratio (BER) when specifying a peak-to-peak jitter limit. Without it, the specification is meaningless. Given that a BER is application specific, many frequency timing devices specify jitter as an RMS. This allows the peak-to-peak jitter to be calculated for the specific application and

BER requirement. Because a standard deviation is the variation from the mean of the data set, it is important to always calculate the peak-to-peak jitter using the typical RMS value.

The table shows the BER with its appropriate RMS Multiplier. Once the BER is chosen, the peak to peak jitter can be calculated by simply multiplying the RMS multiplier with the typical RMS datasheet specification. For example, if a  $10^{-12}$  BER is required, multiply 14.260 times the typical jitter specification.

$$\text{Jitter (peak-to-peak)} = \text{RMS Multiplier} \times \text{RMS (typical)}$$

This calculation is not specific to one type of Jitter classification. It can be used to calculate BER on various types of RMS jitter. It is important that the user understands their jitter requirement to ensure they are calculating the correct BER for their jitter requirement.

BER	RMS Multiplier
$10^{-3}$	6.582
$10^{-4}$	7.782
$10^{-5}$	8.834
$10^{-6}$	9.784
$10^{-7}$	10.654
$10^{-8}$	11.462
$10^{-9}$	12.218
$10^{-10}$	12.934
$10^{-11}$	13.614
$10^{-12}$	14.260
$10^{-13}$	14.882
$10^{-14}$	15.478
$10^{-15}$	16.028

## Power Considerations

This section provides information on power dissipation and junction temperature for the 843441. Equations and example calculations are also provided.

### 1. Power Dissipation.

The total power dissipation for the 843441 is the sum of the core power plus the power dissipated in the load(s). The following is the power dissipation for  $V_{CC} = 3.3V + 5\% = 3.465V$ , which gives worst case results.

NOTE: Please refer to Section 3 for details on calculating power dissipated in the load.

- Power (core)<sub>MAX</sub> =  $V_{CC\_MAX} * I_{EE\_MAX} = 3.465V * 66mA = \mathbf{228.69mW}$
- Power (outputs)<sub>MAX</sub> = **30mW/Loaded Output pair**

**Total Power**<sub>MAX</sub> (3.465V, with all outputs switching) = 228.69mW + 30mW = **258.69mW**

### 2. Junction Temperature.

Junction temperature,  $T_j$ , is the temperature at the junction of the bond wire and bond pad directly affects the reliability of the device. The maximum recommended junction temperature is 125°C. Limiting the internal transistor junction temperature,  $T_j$ , to 125°C ensures that the bond wire and bond pad temperature remains below 125°C.

The equation for  $T_j$  is as follows:  $T_j = \theta_{JA} * Pd\_total + T_A$

$T_j$  = Junction Temperature

$\theta_{JA}$  = Junction-to-Ambient Thermal Resistance

$Pd\_total$  = Total Device Power Dissipation (example calculation is in section 1 above)

$T_A$  = Ambient Temperature

In order to calculate junction temperature, the appropriate junction-to-ambient thermal resistance  $\theta_{JA}$  must be used. Assuming no air flow and a multi-layer board, the appropriate value is 96°C/W per Table 6B below.

Therefore,  $T_j$  for an ambient temperature of 70°C with all outputs switching is:

$70^\circ C + 0.259W * 96^\circ C/W = 94.864^\circ C$ . This is below the limit of 125°C.

This calculation is only an example.  $T_j$  will obviously vary depending on the number of loaded outputs, supply voltage, air flow and the type of board (multi-layer).

**Table 6A. Thermal Resistance  $\theta_{JA}$  for 16 Lead TSSOP, Forced Convection**

$\theta_{JA}$ vs. Air Flow			
Meters per Second	0	1	2.5
Multi-Layer PCB, JEDEC Standard Test Boards	81.2°C/W	73.9°C/W	70.2°C/W

**Table 6B. Thermal Resistance  $\theta_{JA}$  for 8 Lead SOIC, Forced Convection**

$\theta_{JA}$ vs. Air Flow			
Linear Feet per Second	0	200	500
Multi-Layer PCB, JEDEC Standard Test Boards	96°C/W	87°C/W	82°C/W

### 3. Calculations and Equations.

The purpose of this section is to calculate the power dissipation for the LVPECL output pair.

LVPECL output driver circuit and termination are shown in *Figure 4*.

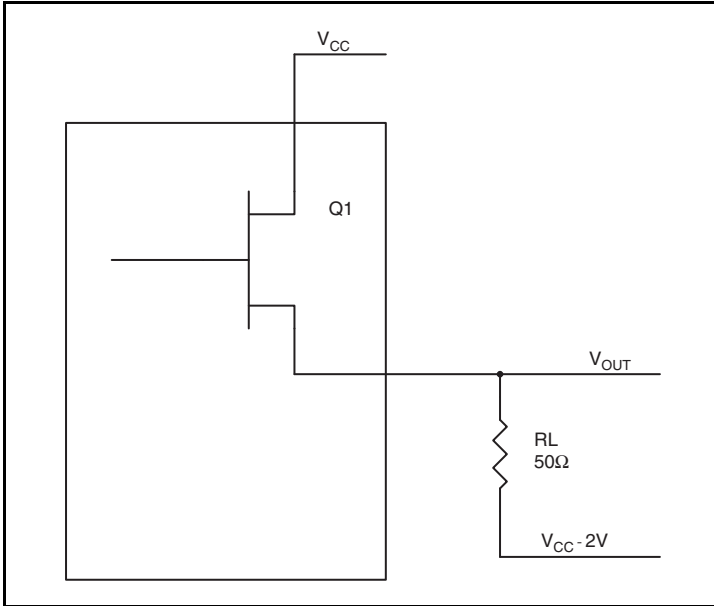

**Figure 4. LVPECL Driver Circuit and Termination**

To calculate worst case power dissipation into the load, use the following equations which assume a 50Ω load, and a termination voltage of V<sub>CC</sub> - 2V.

- For logic high, V<sub>OUT</sub> = V<sub>OH\_MAX</sub> = V<sub>CC\_MAX</sub> - 0.9V  
(V<sub>CC\_MAX</sub> - V<sub>OH\_MAX</sub>) = **0.9V**
- For logic low, V<sub>OUT</sub> = V<sub>OL\_MAX</sub> = V<sub>CC\_MAX</sub> - 1.7V  
(V<sub>CC\_MAX</sub> - V<sub>OL\_MAX</sub>) = **1.7V**

Pd<sub>H</sub> is power dissipation when the output drives high.

Pd<sub>L</sub> is the power dissipation when the output drives low.

$$Pd_H = [(V_{OH\_MAX} - (V_{CC\_MAX} - 2V))/R_L] * (V_{CC\_MAX} - V_{OH\_MAX}) = [(2V - (V_{CC\_MAX} - V_{OH\_MAX}))/R_L] * (V_{CC\_MAX} - V_{OH\_MAX}) = [(2V - 0.9V)/50\Omega] * 0.9V = \mathbf{19.8mW}$$

$$Pd_L = [(V_{OL\_MAX} - (V_{CC\_MAX} - 2V))/R_L] * (V_{CC\_MAX} - V_{OL\_MAX}) = [(2V - (V_{CC\_MAX} - V_{OL\_MAX}))/R_L] * (V_{CC\_MAX} - V_{OL\_MAX}) = [(2V - 1.7V)/50\Omega] * 1.7V = \mathbf{10.2mW}$$

Total Power Dissipation per output pair = Pd<sub>H</sub> + Pd<sub>L</sub> = **30mW**

## Reliability Information

**Table 7A.  $\theta_{JA}$  vs. Air Flow Table for a 16 Lead TSSOP**

$\theta_{JA}$ vs. Air Flow			
Meters per Second	0	1	2.5
Multi-Layer PCB, JEDEC Standard Test Boards	81.2°C/W	73.9°C/W	70.2°C/W

**Table 7B.  $\theta_{JA}$  vs. Air Flow Table for a 8 Lead SOIC**

$\theta_{JA}$ vs. Air Flow			
Linear Feet per Second	0	200	500
Multi-Layer PCB, JEDEC Standard Test Boards	96°C/W	87°C/W	82°C/W

## Transistor Count

The transistor count for 843441 is: 6303

## Package Outline and Package Dimensions

Package Outline - G Suffix for 16-Lead TSSOP

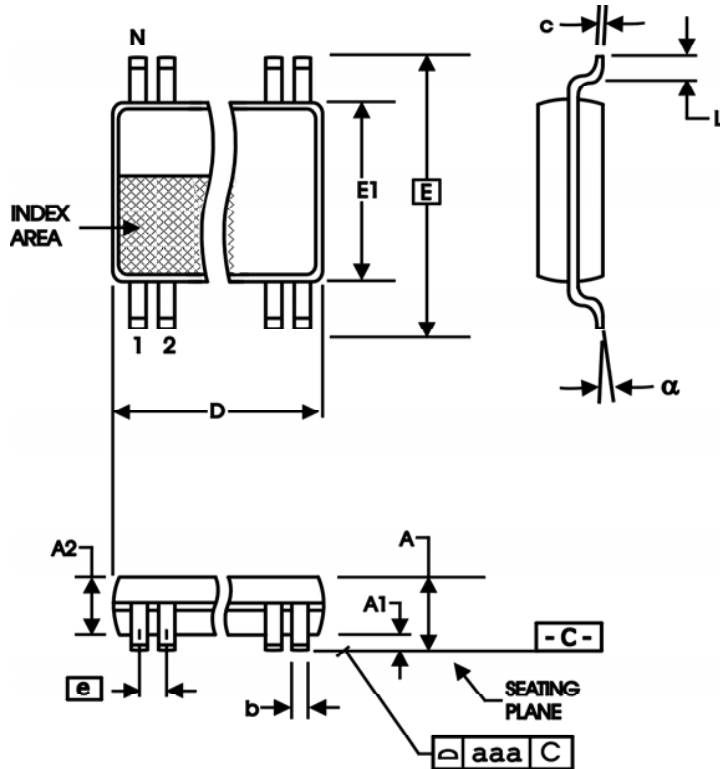

Package Outline - M Suffix for 8 Lead SOIC

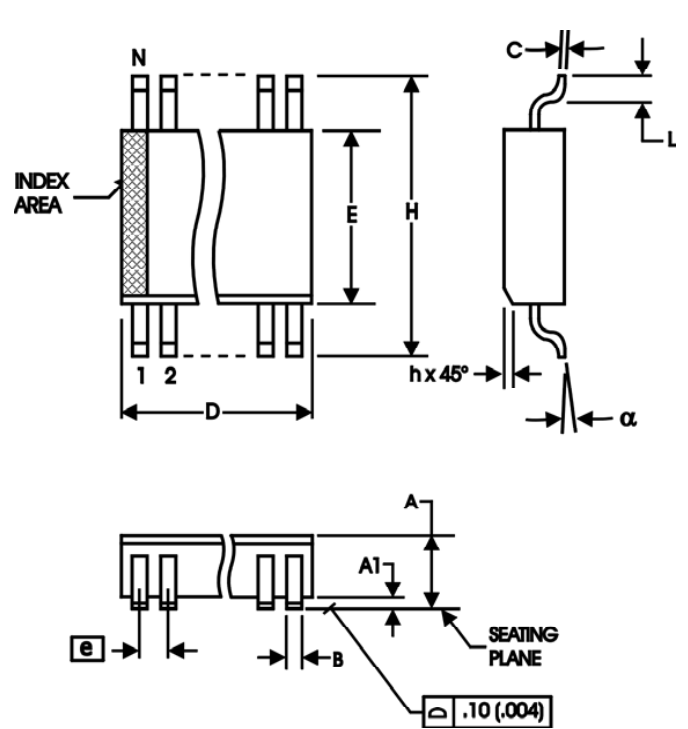

Table 8A. Package Dimensions for 16 Lead TSSOP

All Dimensions in Millimeters		
Symbol	Minimum	Maximum
N	16	
A		1.20
A1	0.05	0.15
A2	0.80	1.05
b	0.19	0.30
c	0.09	0.20
D	4.90	5.10
E	6.40 Basic	
E1	4.30	4.50
e	0.65 Basic	
L	0.45	0.75
α	0°	8°
aaa		0.10

Reference Document: JEDEC Publication 95, MO-153

Table 8B. Package Dimensions for 8 Lead SOIC

All Dimensions in Millimeters		
Symbol	Minimum	Maximum
N	8	
A	1.35	1.75
A1	0.10	0.25
B	0.33	0.51
C	0.19	0.25
D	4.80	5.00
E	3.80	4.00
e	1.27 Basic	
H	5.80	6.20
h	0.25	0.50
L	0.40	1.27
α	0°	8°

Reference Document: JEDEC Publication 95, MS-012

## Ordering Information

Table 9. Ordering Information

Part/Order Number	Marking	Package	Shipping Packaging	Temperature
843441AGLF	843441AL	16 Lead "Lead-Free" TSSOP	Tube	0°C to 70°C
843441AGLFT	843441AL	16 Lead "Lead-Free" TSSOP	Tape & Reel	0°C to 70°C
843441AM-75LF	3441A75L	8 Lead "Lead-Free" SOIC	Tube	0°C to 70°C
843441AM-75LFT	3441A75L	8 Lead "Lead-Free" SOIC	Tape & Reel	0°C to 70°C
843441AM-100LF	441A100L	8 Lead "Lead-Free" SOIC	Tube	0°C to 70°C
843441AM-100LFT	441A100L	8 Lead "Lead-Free" SOIC	Tape & Reel	0°C to 70°C
843441AM-150LF	441A150L	8 Lead "Lead-Free" SOIC	Tube	0°C to 70°C
843441AM-150LFT	441A150L	8 Lead "Lead-Free" SOIC	Tape & Reel	0°C to 70°C
843441AM-300LF	441A300L	8 Lead "Lead-Free" SOIC	Tube	0°C to 70°C
843441AM-300LFT	441A300L	8 Lead "Lead-Free" SOIC	Tape & Reel	0°C to 70°C

## Revision History Sheet

Rev	Table	Page	Description of Change	Date
A	T3A	3	SSC_SEL Function Table - updated Mode column.	5/18/11
A	T9	16	Ordering Information - Removed quantity in tape and reel. Deleted LF note below table. Removed ICS from part number where needed. Product Discontinuation Notice - Last time buy expires May 6, 2017. PDN CQ-16-01 Updated header and footer	6/30/16



Corporate Headquarters  
6024 Silver Creek Valley Road  
San Jose, CA 95138 USA  
[www.IDT.com](http://www.IDT.com)

Sales  
1-800-345-7015 or 408-284-8200  
Fax: 408-284-2775  
[www.IDT.com/go/sales](http://www.IDT.com/go/sales)

Tech Support  
[www.idt.com/go/support](http://www.idt.com/go/support)

DISCLAIMER Integrated Device Technology, Inc. (IDT) reserves the right to modify the products and/or specifications described herein at any time, without notice, at IDT's sole discretion. Performance specifications and operating parameters of the described products are determined in an independent state and are not guaranteed to perform the same way when installed in customer products. The information contained herein is provided without representation or warranty of any kind, whether express or implied, including, but not limited to, the suitability of IDT's products for any particular purpose, an implied warranty of merchantability, or non-infringement of the intellectual property rights of others. This document is presented only as a guide and does not convey any license under intellectual property rights of IDT or any third parties.

IDT's products are not intended for use in applications involving extreme environmental conditions or in life support systems or similar devices where the failure or malfunction of an IDT product can be reasonably expected to significantly affect the health or safety of users. Anyone using an IDT product in such a manner does so at their own risk, absent an express, written agreement by IDT.

Integrated Device Technology, IDT and the IDT logo are trademarks or registered trademarks of IDT and its subsidiaries in the United States and other countries. Other trademarks used herein are the property of IDT or their respective third party owners. For datasheet type definitions and a glossary of common terms, visit [www.idt.com/go/glossary](http://www.idt.com/go/glossary). Integrated Device Technology, Inc. All rights reserved.

## IMPORTANT NOTICE AND DISCLAIMER

RENESAS ELECTRONICS CORPORATION AND ITS SUBSIDIARIES (“RENESAS”) PROVIDES TECHNICAL SPECIFICATIONS AND RELIABILITY DATA (INCLUDING DATASHEETS), DESIGN RESOURCES (INCLUDING REFERENCE DESIGNS), APPLICATION OR OTHER DESIGN ADVICE, WEB TOOLS, SAFETY INFORMATION, AND OTHER RESOURCES “AS IS” AND WITH ALL FAULTS, AND DISCLAIMS ALL WARRANTIES, EXPRESS OR IMPLIED, INCLUDING, WITHOUT LIMITATION, ANY IMPLIED WARRANTIES OF MERCHANTABILITY, FITNESS FOR A PARTICULAR PURPOSE, OR NON-INFRINGEMENT OF THIRD-PARTY INTELLECTUAL PROPERTY RIGHTS.

These resources are intended for developers who are designing with Renesas products. You are solely responsible for (1) selecting the appropriate products for your application, (2) designing, validating, and testing your application, and (3) ensuring your application meets applicable standards, and any other safety, security, or other requirements. These resources are subject to change without notice. Renesas grants you permission to use these resources only to develop an application that uses Renesas products. Other reproduction or use of these resources is strictly prohibited. No license is granted to any other Renesas intellectual property or to any third-party intellectual property. Renesas disclaims responsibility for, and you will fully indemnify Renesas and its representatives against, any claims, damages, costs, losses, or liabilities arising from your use of these resources. Renesas' products are provided only subject to Renesas' Terms and Conditions of Sale or other applicable terms agreed to in writing. No use of any Renesas resources expands or otherwise alters any applicable warranties or warranty disclaimers for these products.

(Disclaimer Rev.1.01)

### Corporate Headquarters

TOYOSU FORESIA, 3-2-24 Toyosu,  
Koto-ku, Tokyo 135-0061, Japan  
[www.renesas.com](http://www.renesas.com)

### Trademarks

Renesas and the Renesas logo are trademarks of Renesas Electronics Corporation. All trademarks and registered trademarks are the property of their respective owners.

### Contact Information

For further information on a product, technology, the most up-to-date version of a document, or your nearest sales office, please visit [www.renesas.com/contact-us/](http://www.renesas.com/contact-us/).