

General Description

The 843S104I-133 is a PLL-based clock synthesizer specifically designed for low phase noise applications. This device generates a 133.33MHz differential LVPECL clock from an input reference of 25MHz. The input reference may be derived from an external source or by the addition of a 25MHz crystal to the on-chip crystal oscillator. An external reference is applied to the PCLK, nPCLK pins. The device offers spread spectrum clock output for reduced EMI applications. An I²C bus interface is used to enable or disable spread spectrum operation as well as to select either a down spread value of -0.35% or -0.5%. The 843S104I-133 is available in a lead-free 32-Lead VFQFN package.

Features

- Four LVPECL output pairs
- Crystal oscillator interface: 25MHz
- Differential PCLK, nPCLK input pair
- PCLK, nPCLK supports the following input types: LVPECL, CML, SSTL
- Output frequency: 133.33MHz
- PCI Express (2.5 Gb/s) and Gen 2 (5 Gb/S) jitter compliant
- RMS phase jitter @ 133.33MHz (12kHz – 20MHz): 1.2ps (typical)
- I²C support with readback capabilities up to 400kHz
- Spread Spectrum for electromagnetic interference (EMI) reduction
- 3.3V operating supply mode
- -40°C to 85°C ambient operating temperature
- Available lead-free (RoHS 6) package

Block Diagram

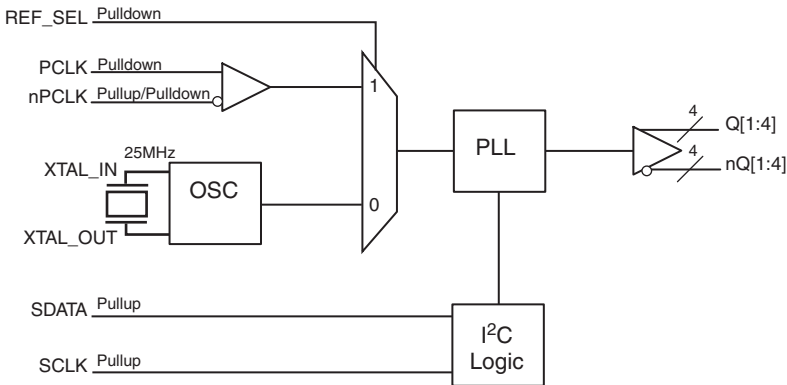

Pin Assignment

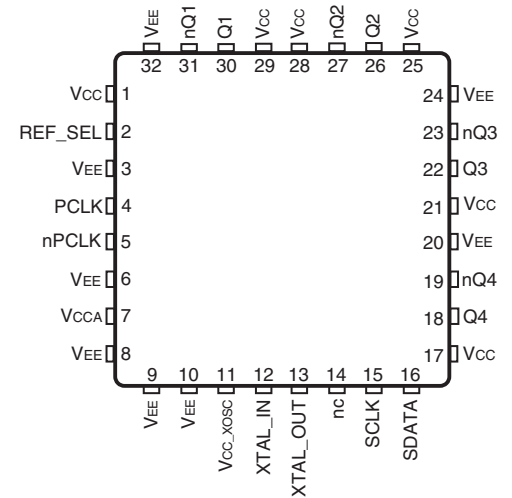

843S104I-133
32-Lead VFQFN
5.0mm x 5.0mm package body

Table 1. Pin Descriptions

Number	Name	Type		Description
1, 17, 21, 25, 28, 29	V _{CC}	Power		Core supply pins.
2	REF_SEL	Input	Pulldown	Select input for XTAL (LOW) or REF_IN (HIGH). LVCMOS/LVTTL interface levels.
3, 6, 8, 9, 10, 20, 24, 32	V _{EE}	Power		Negative power supply pins.
4	PCLK	Input	Pulldown	Non-inverting external 25MHz differential reference input. LVPECL input levels.
5	nPCLK	Input	Pullup/ Pulldown	Inverting external 25MHz differential reference input. LVPECL input levels.
7	V _{CCA}	Power		Analog supply for PLL.
11	V _{CC_XOSC}	Power		Analog supply for crystal oscillator.
12, 13	XTAL_IN, XTAL_OUT	Input		Crystal oscillator interface. XTAL_IN is the input. XTAL_OUT is the output.
14	nc	Unused		No connect.
15	SCLK	Input	Pullup	I ² C compatible SCLK. This pin has an internal pullup resistor. LVCMOS/LVTTL interface levels.
16	SDATA	I/O	Pullup	I ² C compatible SDATA. This pin has an internal pullup resistor. LVCMOS/LVTTL interface levels.
18,19	Q4, nQ4	Output		Differential output pair. LVPECL interface levels.
22, 23	Q3, nQ3	Output		Differential output pair. LVPECL interface levels.
26, 27	Q2, nQ2	Output		Differential output pair. LVPECL interface levels.
30, 31	Q1, nQ1	Output		Differential output pair. LVPECL interface levels.

NOTE: *Pullup and Pulldown* refers to internal input resistors. See Table 2, *Pin Characteristics*, for typical values.

Table 2. Pin Characteristics

Symbol	Parameter	Test Conditions	Minimum	Typical	Maximum	Units
C _{IN}	Input Capacitance			4		pF
R _{PULLUP}	Input Pullup Resistor			51		kΩ
R _{PULLDOWN}	Input Pulldown Resistor			51		kΩ

Serial Data Interface

To enhance the flexibility and function of the clock synthesizer, a two-signal I²C serial interface is provided. Through the Serial Data Interface, various device functions, such as individual clock output buffers, can be individually enabled or disabled. The registers

associated with the serial interface initialize to their default settings upon power-up, and therefore, use of this interface is optional. Clock device register changes are normally made upon system initialization, if any are required.

Data Protocol

The clock driver serial protocol accepts byte write, byte read, block write and block read operations from the controller. For block write/read operations, the bytes must be accessed in sequential order from lowest to highest byte (most significant bit first) with the ability to stop after any complete byte has been transferred. For byte write and byte read operations, the system controller can access individually

indexed bytes. The offset of the indexed byte is encoded in the command code, as described in Table 3A.

The block write and block read protocol is outlined in Table 3B, while Table 3C outlines the corresponding byte write and byte read protocol. The slave receiver address is 11010010 (D2h).

Table 3A. Command Code Definition

Bit	7	6, 5	4:0
Description	0 = Block read or block write operation, 1 = Byte read or byte write operation.	Chip select address, set to "00" to access device.	Byte offset for byte read or byte write operation. For block read or block write operations, these bits must be "0000".

Table 3B. Block Read and Block Write Protocol

Bit	Description = Block Write	Bit	Description = Block Read
1	Start	1	Start
2:8	Slave address - 7 bits	2:8	Slave address - 7 bits
9	Write	9	Write
10	Acknowledge from slave	10	Acknowledge from slave
11:18	Command Code - 8 bits	11:18	Command Code - 8 bits
19	Acknowledge from slave	19	Acknowledge from slave
20:27	Byte Count - 8 bits	20	Repeat start
28	Acknowledge from slave	21:27	Slave address - 7 bits
29:36	Data byte 1 - 8 bits	28	Read = 1
37	Acknowledge from slave	29	Acknowledge from slave
38:45	Data byte 2 - 8 bits	30:37	Byte Count from slave - 8 bits
46	Acknowledge from slave	38	Acknowledge
	Data Byte/Slave Acknowledges	39:46	Data Byte 1 from slave - 8 bits
	Data Byte N - 8 bits	47	Acknowledge
	Acknowledge from slave	48:55	Data Byte 2 from slave - 8 bits
	Stop	56	Acknowledge
			Data Bytes from Slave/Acknowledge
			Data Byte N from slave - 8 bits
			Not Acknowledge
			Stop

Table 3C. Byte Read and Byte Write Protocol

Bit	Description = Byte Write	Bit	Description = Byte Read
1	Start	1	Start
2:8	Slave address - 7 bits	2:8	Slave address - 7 bits
9	Write	9	Write
10	Acknowledge from slave	10	Acknowledge from slave
11:18	Command Code - 8 bits	11:18	Command Code - 8 bits
19	Acknowledge from slave	19	Acknowledge from slave
20:27	Data byte - 8 bits	20	Repeat start
28	Acknowledge from slave	21:27	Slave address - 7 bits
29	Stop	28	Read
		29	Acknowledge from slave
		30:37	Data from slave - 8 bits
		38	Not Acknowledge
		39	Stop

Control Registers

Table 3D. Byte 0: Control Register 0

Bit	@Power-up	Name	Description
7	0	Reserved	Reserved
6	1	Q4EN	Q4, nQ4 Output Enable 0 = Low 1 = Enable
5	1	Q3EN	Q3, nQ3 Output Enable 0 = Low 1 = Enable
4	1	Q2EN	Q2, nQ2 Output Enable 0 = Low 1 = Enable
3	1	Q1EN	Q1, nQ1 Output Enable 0 = Low 1 = Enable
2	1	Reserved	Reserved
1	0	Reserved	Reserved
0	0	Reserved	Reserved

Table 3E. Byte 1: Control Register 1

Bit	@Power-up	Name	Description
7	0	Reserved	Reserved
6	0	Reserved	Reserved
5	0	Reserved	Reserved
4	0	Reserved	Reserved
3	0	Reserved	Reserved
2	0	Reserved	Reserved
1	0	Reserved	Reserved
0	0	Reserved	Reserved

Table 3F. Byte 2: Control Register 2

Bit	@Power-up	Name	Description
7	1	SS_SEL	Spread Spectrum Selection 0 = -0.35%, 1 = -0.5%
6	1	Reserved	Reserved
5	1	Reserved	Reserved
4	0	Reserved	Reserved
3	1	Reserved	Reserved
2	0	SSM	Q Spread Spectrum Enable 0 = Spread Off, 1 = Spread On
1	1	Reserved	Reserved
0	0	Reserved	Reserved

Table 3G. Byte 3: Control Register 3

Bit	@Power-up	Name	Description
7	1	Reserved	Reserved
6	0	Reserved	Reserved
5	1	Reserved	Reserved
4	0	Reserved	Reserved
3	1	Reserved	Reserved
2	1	Reserved	Reserved
1	1	Reserved	Reserved
0	1	Reserved	Reserved

Table 3H. Byte 4: Control Register 4

Bit	@Power-up	Name	Description
7	0	Reserved	Reserved
6	0	Reserved	Reserved
5	0	Reserved	Reserved
4	0	Reserved	Reserved
3	0	Reserved	Reserved
2	0	Reserved	Reserved
1	0	Reserved	Reserved
0	1	Reserved	Reserved

Table 3I. Byte 5: Control Register 5

Bit	@Power-up	Name	Description
7	0	Reserved	Reserved
6	0	Reserved	Reserved
5	0	Reserved	Reserved
4	0	Reserved	Reserved
3	0	Reserved	Reserved
2	0	Reserved	Reserved
1	0	Reserved	Reserved
0	0	Reserved	Reserved

Table 3J. Byte 6: Control Register 6

Bit	@Power-up	Name	Description
7	0	TEST_SEL	REF/N or Hi-Z Select 0 = Hi-Z, 1 = REF/N
6	0	TEST_MODE	TEST Clock Mode Entry Control 0 = Normal Operation, 1 = REF/N or Hi-Z Mode
5	0	Reserved	Reserved
4	1	Reserved	Reserved
3	0	Reserved	Reserved
2	0	Reserved	Reserved
1	1	Reserved	Reserved
0	1	Reserved	Reserved

Table 3K. Byte 7: Control Register 7

Bit	@Power-up	Name	Description
7	0		Revision Code Bit 3
6	0		Revision Code Bit 2
5	0		Revision Code Bit 1
4	0		Revision Code Bit 0
3	0		Vendor ID Bit 3
2	0		Vendor ID Bit 2
1	0		Vendor ID Bit 1
0	1		Vendor ID Bit 0

Absolute Maximum Ratings

NOTE: Stresses beyond those listed under *Absolute Maximum Ratings* may cause permanent damage to the device. These ratings are stress specifications only. Functional operation of product at these conditions or any conditions beyond those listed in the *DC Characteristics* or *AC Characteristics* is not implied. Exposure to absolute maximum rating conditions for extended periods may affect product reliability.

Item	Rating
Supply Voltage, V_{CC}	4.6V
Inputs, V_I	-0.5V to $V_{CC} + 0.5V$
Outputs, I_O (LVPECL) Continuous Current Surge Current	50mA 100mA
Package Thermal Impedance, θ_{JA}	39.5°C/W (0 mps)
Storage Temperature, T_{STG}	-65°C to 150°C

DC Electrical Characteristics

Table 4A. Power Supply DC Characteristics, $V_{CC} = 3.3V \pm 5\%$, $T_A = -40^\circ C$ to $85^\circ C$

Symbol	Parameter	Test Conditions	Minimum	Typical	Maximum	Units
V_{CC}	Core Supply Voltage		3.135	3.3	3.465	V
V_{CCA}	Analog Supply Voltage		$V_{CC} - 0.22$	3.3	V_{CC}	V
V_{CC_XOSC}	Analog Supply Voltage		$V_{CC} - 0.05$	3.3	V_{CC}	V
I_{EE}	Power Supply Current				130	mA
I_{CCA}	Analog Supply Current				22	mA
I_{CC_XOSC}	Crystal Oscillator Supply Current				5	mA

Table 4B. LVCMOS/LVTTL DC Characteristics, $V_{CC} = 3.3V \pm 5\%$, $T_A = -40^{\circ}C$ to $85^{\circ}C$

Symbol	Parameter		Test Conditions	Minimum	Typical	Maximum	Units
V_{IH}	Input High Voltage	SDATA, SCLK		2.0		$V_{CC} + 0.3$	V
V_{IL}	Input Low Voltage	SDATA, SCLK		1.7		$V_{CC} + 0.3$	V
I_{IH}	Input High Current	SDATA, SCLK	$V_{CC} = V_{IN} = 3.465V$			10	μA
		REF_SEL	$V_{CC} = V_{IN} = 3.465V$			150	μA
I_{IL}	Input Low Current	SDATA, SCLK	$V_{CC} = 3.465V, V_{IN} = 0V$	-150			μA
		REF_SEL	$V_{CC} = 3.465V, V_{IN} = 0V$	-10			μA

Table 4C. LVPECL DC Characteristics, $V_{CC} = 3.3V \pm 5\%$, $V_{EE} = 0V$, $T_A = -40^{\circ}C$ to $85^{\circ}C$

Symbol	Parameter		Test Conditions	Minimum	Typical	Maximum	Units
I_{IH}	Input High Current	PCLK, nPCLK	$V_{CC} = V_{IN} = 3.465V$			150	μA
I_{IL}	Input Low Current	PCLK	$V_{CC} = 3.465V, V_{IN} = 0V$	-10			μA
		nPCLK	$V_{CC} = 3.465V, V_{IN} = 0V$	-150			μA
V_{PP}	Peak-to-Peak Voltage; NOTE 1			0.3		1.0	V
V_{CMR}	Common Mode Input Voltage; NOTE 1, 2			$V_{EE} + 1.5$		V_{CC}	V
V_{OH}	Output High Voltage; NOTE 3			$V_{CC} - 1.3$		$V_{CC} - 0.8$	V
V_{OL}	Output Low Voltage; NOTE 3			$V_{CC} - 2.0$		$V_{CC} - 1.6$	V
V_{SWING}	Peak-to-Peak Output Voltage Swing			0.6		1.0	V

NOTE 1: V_{IL} should not be less than -0.3V.

NOTE 2: Common mode input voltage is defined as V_{IH} .

NOTE 3: Outputs terminated with 50Ω to $V_{CC} - 2V$.

Table 5. Crystal Characteristics

Parameter	Test Conditions	Minimum	Typical	Maximum	Units
Mode of Oscillation		Fundamental			
Frequency			25		MHz
Equivalent Series Resistance (ESR)				50	Ω
Shunt Capacitance				7	pF

NOTE: Characterized using an 18pF parallel resonant crystal.

AC Electrical Characteristics

Table 6. AC Characteristics, $V_{CC} = 3.3V \pm 5\%$, $T_A = -40^{\circ}C$ to $85^{\circ}C$

Symbol	Parameter	Test Conditions	Minimum	Typical	Maximum	Units
f_{MAX}	Output Frequency			133.33		MHz
f_{REF}	Reference Frequency			25		MHz
$\sigma_{jit}(\emptyset)$	RMS Phase Jitter, (Random); NOTE 1	SSC Off, Integration Range: 12kHz – 20MHz		1.2		ps
t_j	Phase Jitter Peak-to-Peak; NOTE 2	Evaluation Band: 0Hz - Nyquist (clock frequency/2)		11		ps
$t_{REFCLK_HF_RMS}$	Phase Jitter rms; NOTE 3	133.33MHz 25MHz crystal input High Band: 1.5MHz - Nyquist (clock frequency/2)		1.3		ps
$t_{REFCLK_LF_RMS}$	Phase Jitter rms; NOTE 3	133.33MHz 25MHz crystal input Low Band: 10kHz - 1.5MHz		0.21		ps
odc	Output Duty Cycle		49		51	%
t_R / t_F	Output Rise/Fall Time		100		250	ps

NOTE: Electrical parameters are guaranteed over the specified ambient operating temperature range, which is established when the device is mounted in a test socket with maintained transverse airflow greater than 500 lfm. The device will meet specifications after thermal equilibrium has been reached under these conditions.

NOTE 1: Please refer to Phase Noise Plot.

NOTE 2: Peak-to-Peak jitter after applying system transfer function for the Common Clock Architecture. Maximum limit for PCI Express Gen 1 is 86ps peak-to-peak for a sample size of 10^6 clock periods. See IDT Application Note *PCI Express Reference Clock Requirements* and also the PCI Express Application section of this datasheet which show each individual transfer function and the overall composite transfer function.

NOTE 3: RMS jitter after applying the two evaluation bands to the two transfer functions defined in the Common Clock Architecture and reporting the worst case results for each evaluation band. Maximum limit for PCI Express Generation 2 is 3.1ps rms for $t_{REFCLK_HF_RMS}$ (High Band) and 3.0 ps RMS for $t_{REFCLK_LF_RMS}$ (Low Band). See IDT Application Note *PCI Express Reference Clock Requirements* and also the PCI Express Application section of this datasheet which show each individual transfer function and the overall composite transfer function.

Typical Phase Noise at 133.33MHz

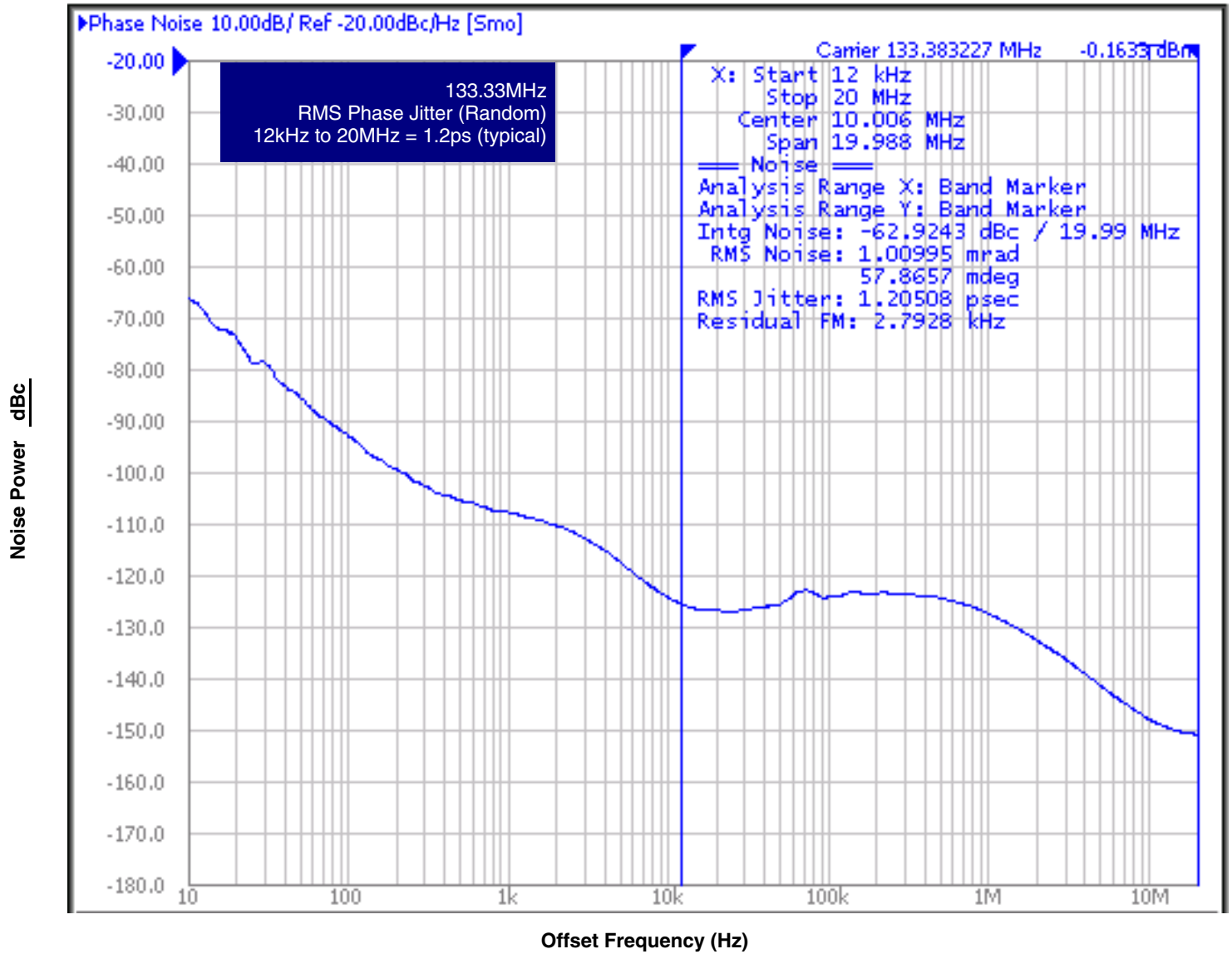

Parameter Measurement Information

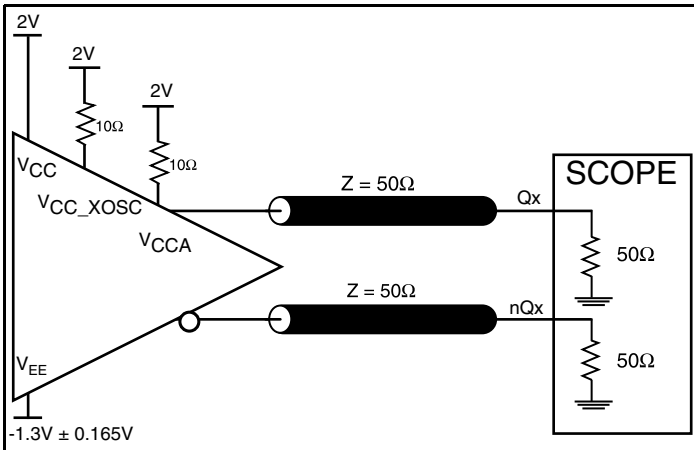

3.3V LVPECL Output Load AC Test Circuit

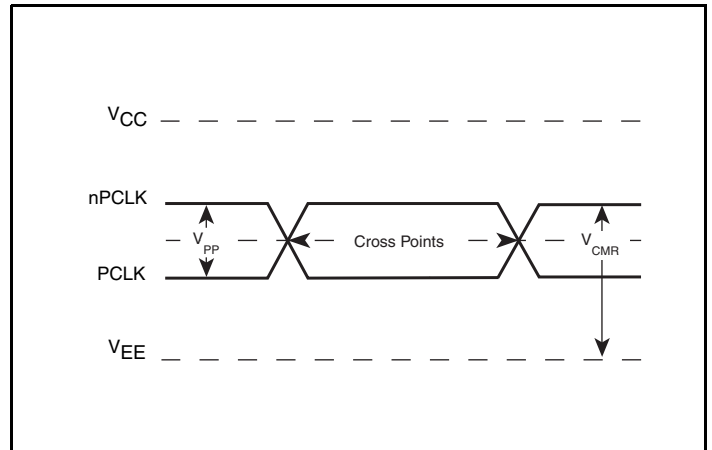

Differential Input Level

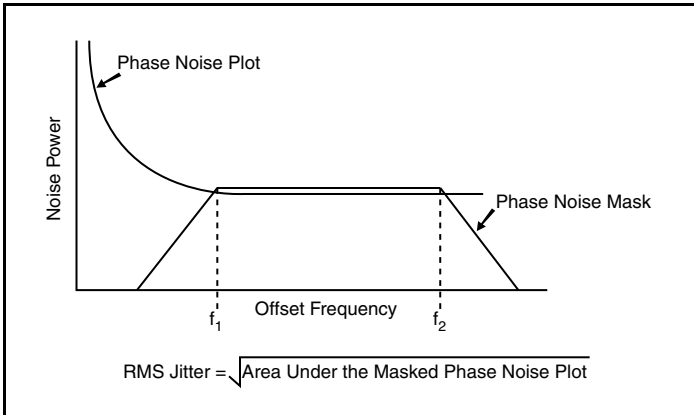

RMS Phase Jitter

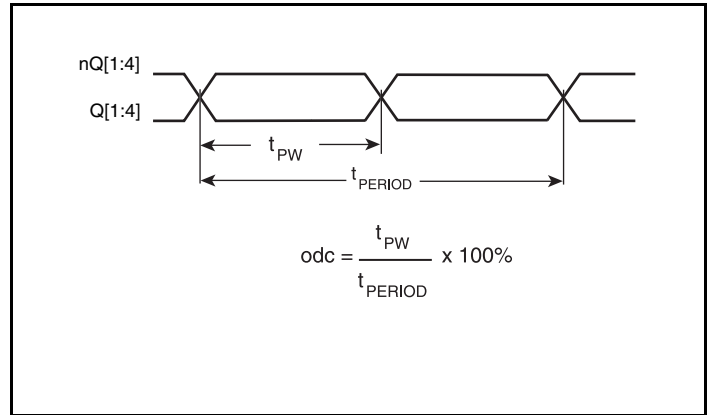

Output Duty Cycle/Pulse Width/Period

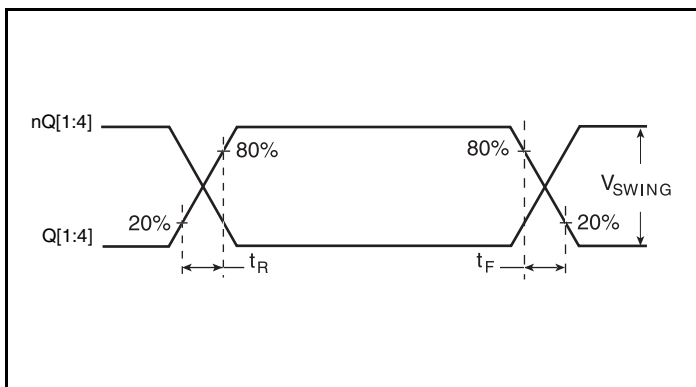

Rise/Fall Time

Applications Information

Power Supply Filtering Technique

As in any high speed analog circuitry, the power supply pins are vulnerable to random noise. To achieve optimum jitter performance, power supply isolation is required. The 843S104I-133 provides separate power supplies to isolate any high switching noise from the outputs to the internal PLL. V_{CC} , V_{CC_XOSC} and V_{CCA} should be individually connected to the power supply plane through vias, and $0.01\mu\text{F}$ bypass capacitors should be used for each pin. *Figure 1* illustrates this for a generic V_{CC} pin and also shows that V_{CCA} requires that an additional 10Ω resistor along with a $10\mu\text{F}$ bypass capacitor be connected to the V_{CCA} pin.

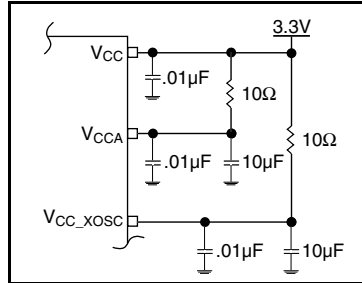

Figure 1. Power Supply Filtering

Recommendations for Unused Input and Output Pins

Inputs:

LVCMOS Control Pins

All control pins have internal pullup and pulldowns; additional resistance is not required but can be added for additional protection. A $1\text{k}\Omega$ resistor can be used.

Crystal Inputs

For applications not requiring the use of the crystal oscillator input, both XTAL_IN and XTAL_OUT can be left floating. Though not required, but for additional protection, a $1\text{k}\Omega$ resistor can be tied from XTAL_IN to ground.

PCLK/nPCLK Inputs

For applications not requiring the use of a differential input, both the PCLK and nPCLK pins can be left floating. Though not required, but for additional protection, a $1\text{k}\Omega$ resistor can be tied from PCLK to ground.

Crystal Input Interface

The 843S104I-133 has been characterized with 18pF parallel resonant crystals. The capacitor values, C1 and C2, shown in *Figure 2* below were determined using a 25MHz , 18pF parallel resonant crystal and were chosen to minimize the ppm error. The optimum C1 and C2 values can be slightly adjusted for different board layouts.

Outputs:

LVPECL Outputs

All unused LVPECL outputs can be left floating. We recommend that there is no trace attached. Both sides of the differential output pair should either be left floating or terminated.

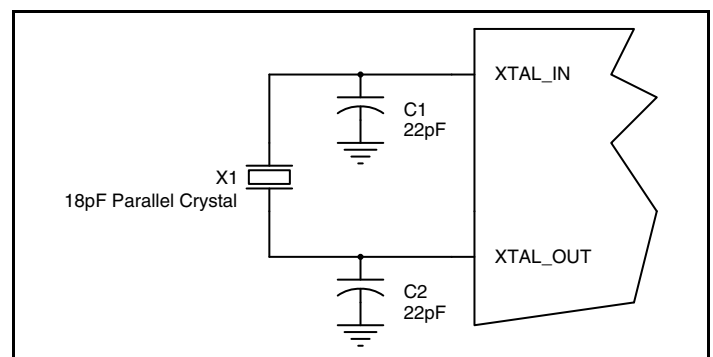

Figure 2. Crystal Input Interface

Overdriving the XTAL Interface

The XTAL_IN input can be overdriven by an LVCMOS driver or by one side of a differential driver through an AC coupling capacitor. The XTAL_OUT pin can be left floating. The amplitude of the input signal should be between 500mV and 1.8V and the slew rate should not be less than 0.2V/ns. For 3.3V LVCMOS inputs, the amplitude must be reduced from full swing to at least half the swing in order to prevent signal interference with the power rail and to reduce internal noise. *Figure 3A* shows an example of the interface diagram for a high speed 3.3V LVCMOS driver. This configuration requires that the sum of the output impedance of the driver (R_o) and the series resistance (R_s) equals the transmission line impedance. In addition, matched termination at the crystal input will attenuate the signal in half. This

can be done in one of two ways. First, R_1 and R_2 in parallel should equal the transmission line impedance. For most 50Ω applications, R_1 and R_2 can be 100Ω. This can also be accomplished by removing R_1 and changing R_2 to 50Ω. The values of the resistors can be increased to reduce the loading for a slower and weaker LVCMOS driver. *Figure 3B* shows an example of the interface diagram for an LVPECL driver. This is a standard LVPECL termination with one side of the driver feeding the XTAL_IN input. It is recommended that all components in the schematics be placed in the layout. Though some components might not be used, they can be utilized for debugging purposes. The datasheet specifications are characterized and guaranteed by using a quartz crystal as the input.

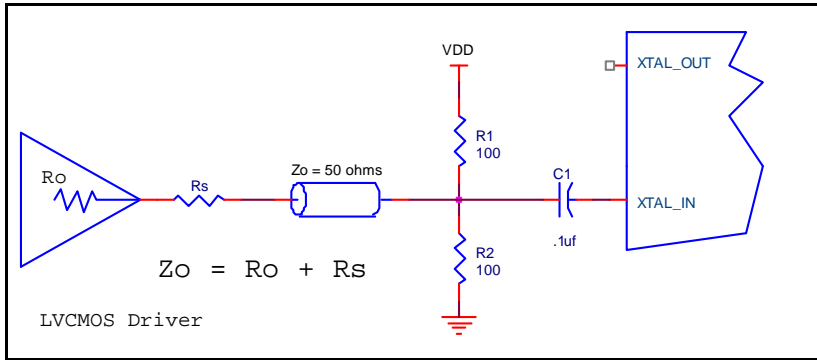

Figure 3A. General Diagram for LVCMOS Driver to XTAL Input Interface

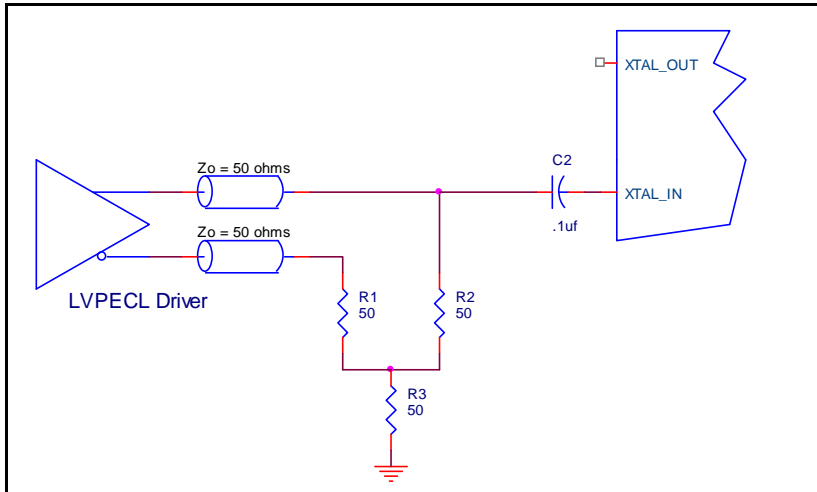

Figure 3B. General Diagram for LVPECL Driver to XTAL Input Interface

LVPECL Clock Input Interface

The PCLK /nPCLK accepts LVPECL, CML, SSTL and other differential signals. Both V_{SWING} and V_{OH} must meet the V_{PP} and V_{CMR} input requirements. Figures 4A to 4F show interface examples for PCLK/nPCLK input driven by the most common driver types. The

input interfaces suggested here are examples only. If the driver is from another vendor, use their termination recommendation. Please consult with the vendor of the driver component to confirm the driver termination requirements.

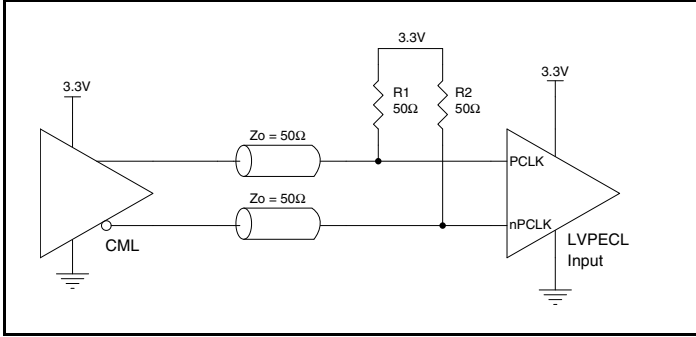

Figure 4A. PCLK/nPCLK Input Driven by a CML Driver

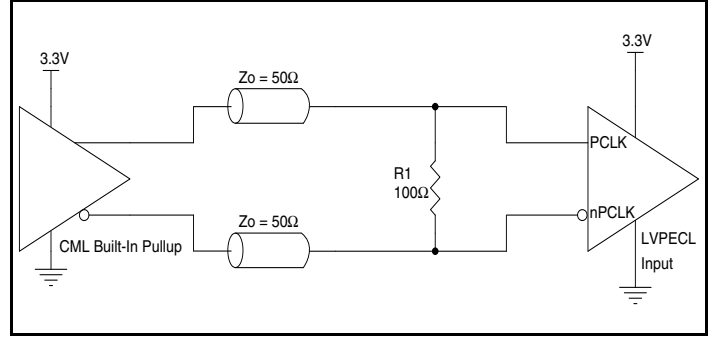

Figure 4B. PCLK/nPCLK Input Driven by a Built-In Pullup CML Driver

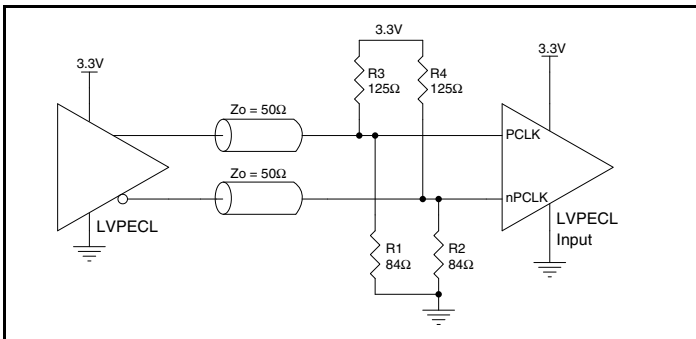

Figure 4C. PCLK/nPCLK Input Driven by a 3.3V LVPECL Driver

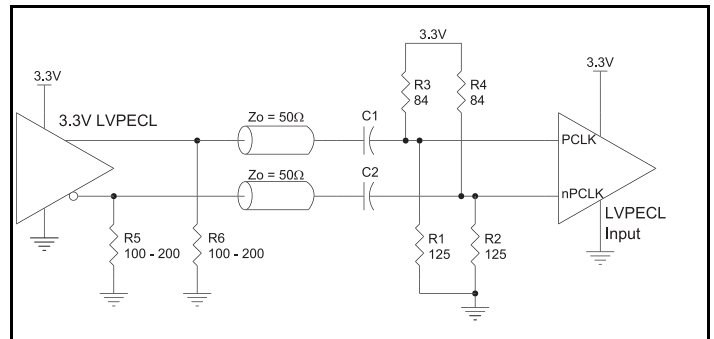

Figure 4D. PCLK/nPCLK Input Driven by a 3.3V LVPECL Driver with AC Couple

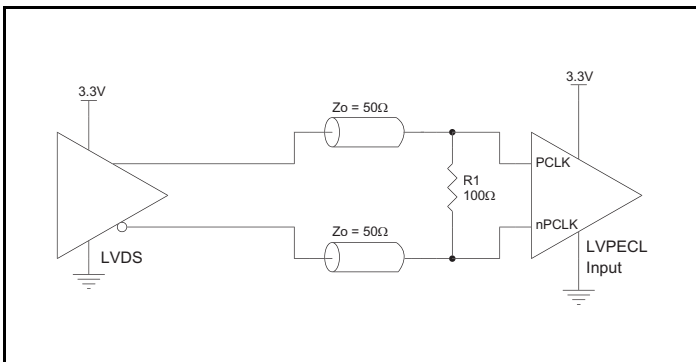

Figure 4E. PCLK/nPCLK Input Driven by a 3.3V LVDS Driver

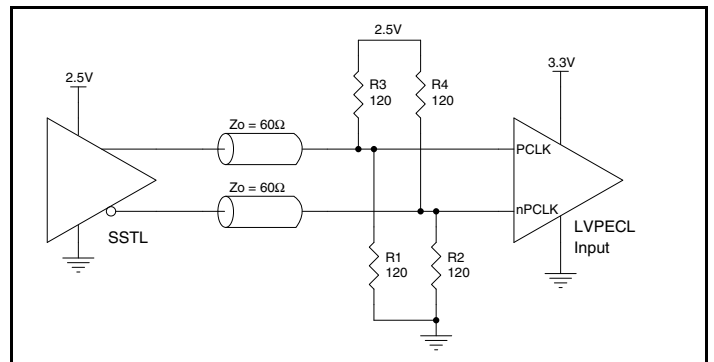

Figure 4F. PCLK/nPCLK Input Driven by an SSTL Driver

Termination for 3.3V LVPECL Outputs

The clock layout topology shown below is a typical termination for LVPECL outputs. The two different layouts mentioned are recommended only as guidelines.

The differential outputs are low impedance follower outputs that generate ECL/LVPECL compatible outputs. Therefore, terminating resistors (DC current path to ground) or current sources must be used for functionality. These outputs are designed to drive 50Ω

transmission lines. Matched impedance techniques should be used to maximize operating frequency and minimize signal distortion. *Figures 5A and 5B* show two different layouts which are recommended only as guidelines. Other suitable clock layouts may exist and it would be recommended that the board designers simulate to guarantee compatibility across all printed circuit and clock component process variations.

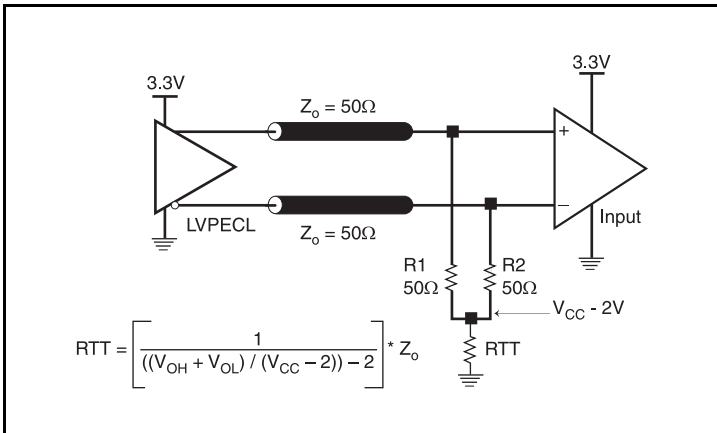

Figure 5A. 3.3V LVPECL Output Termination

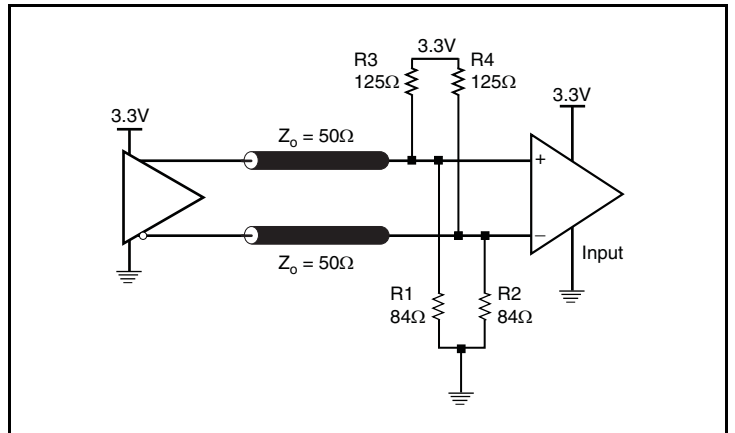

Figure 5B. 3.3V LVPECL Output Termination

VFQFN EPAD Thermal Release Path

In order to maximize both the removal of heat from the package and the electrical performance, a land pattern must be incorporated on the Printed Circuit Board (PCB) within the footprint of the package corresponding to the exposed metal pad or exposed heat slug on the package, as shown in *Figure 6*. The solderable area on the PCB, as defined by the solder mask, should be at least the same size/shape as the exposed pad/slug area on the package to maximize the thermal/electrical performance. Sufficient clearance should be designed on the PCB between the outer edges of the land pattern and the inner edges of pad pattern for the leads to avoid any shorts.

While the land pattern on the PCB provides a means of heat transfer and electrical grounding from the package to the board through a solder joint, thermal vias are necessary to effectively conduct from the surface of the PCB to the ground plane(s). The land pattern must be connected to ground through these vias. The vias act as "heat pipes". The number of vias (i.e. "heat pipes") are application specific

and dependent upon the package power dissipation as well as electrical conductivity requirements. Thus, thermal and electrical analysis and/or testing are recommended to determine the minimum number needed. Maximum thermal and electrical performance is achieved when an array of vias is incorporated in the land pattern. It is recommended to use as many vias connected to ground as possible. It is also recommended that the via diameter should be 12 to 13mils (0.30 to 0.33mm) with 1 oz copper via barrel plating. This is desirable to avoid any solder wicking inside the via during the soldering process which may result in voids in solder between the exposed pad/slug and the thermal land. Precautions should be taken to eliminate any solder voids between the exposed heat slug and the land pattern. Note: These recommendations are to be used as a guideline only. For further information, please refer to the Application Note on the Surface Mount Assembly of Amkor's Thermally/Electrically Enhance Leadframe Base Package, Amkor Technology.

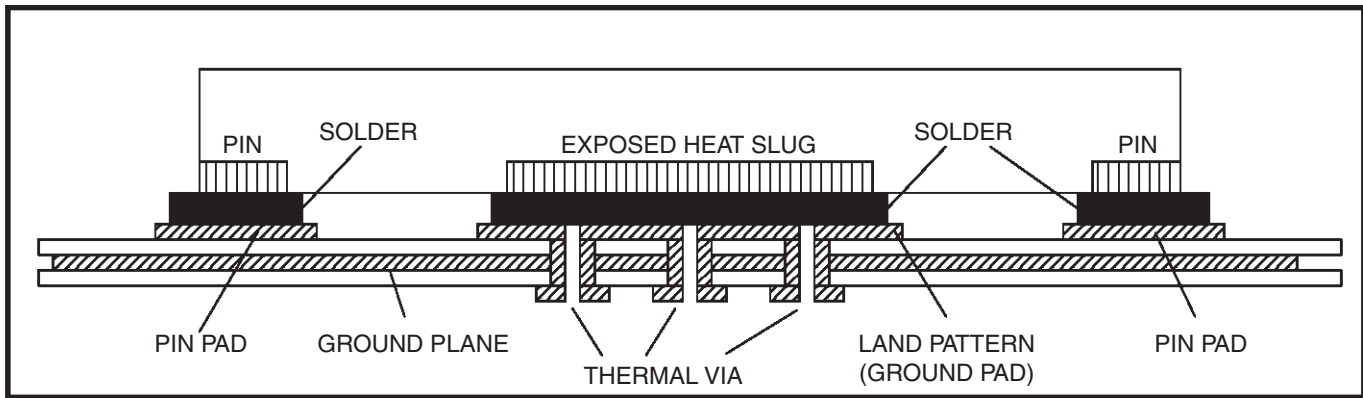

Figure 6. P.C. Assembly for Exposed Pad Thermal Release Path – Side View (drawing not to scale)

Schematic Example

Figure 7 shows an example of 843S104I-133 application schematic. In this example, the device is operated at $V_{CC} = 3.3V$. The 18pF parallel resonant 25MHz crystal is used. The C1 and C2 = 22pF are recommended for frequency accuracy. For different board layouts, the C1 and C2 may be slightly adjusted for optimizing

frequency accuracy. for the LVPECL output drivers, only two termination examples are shown in this schematic. Additional termination approaches are shown in the LVPECL Termination Application Note.

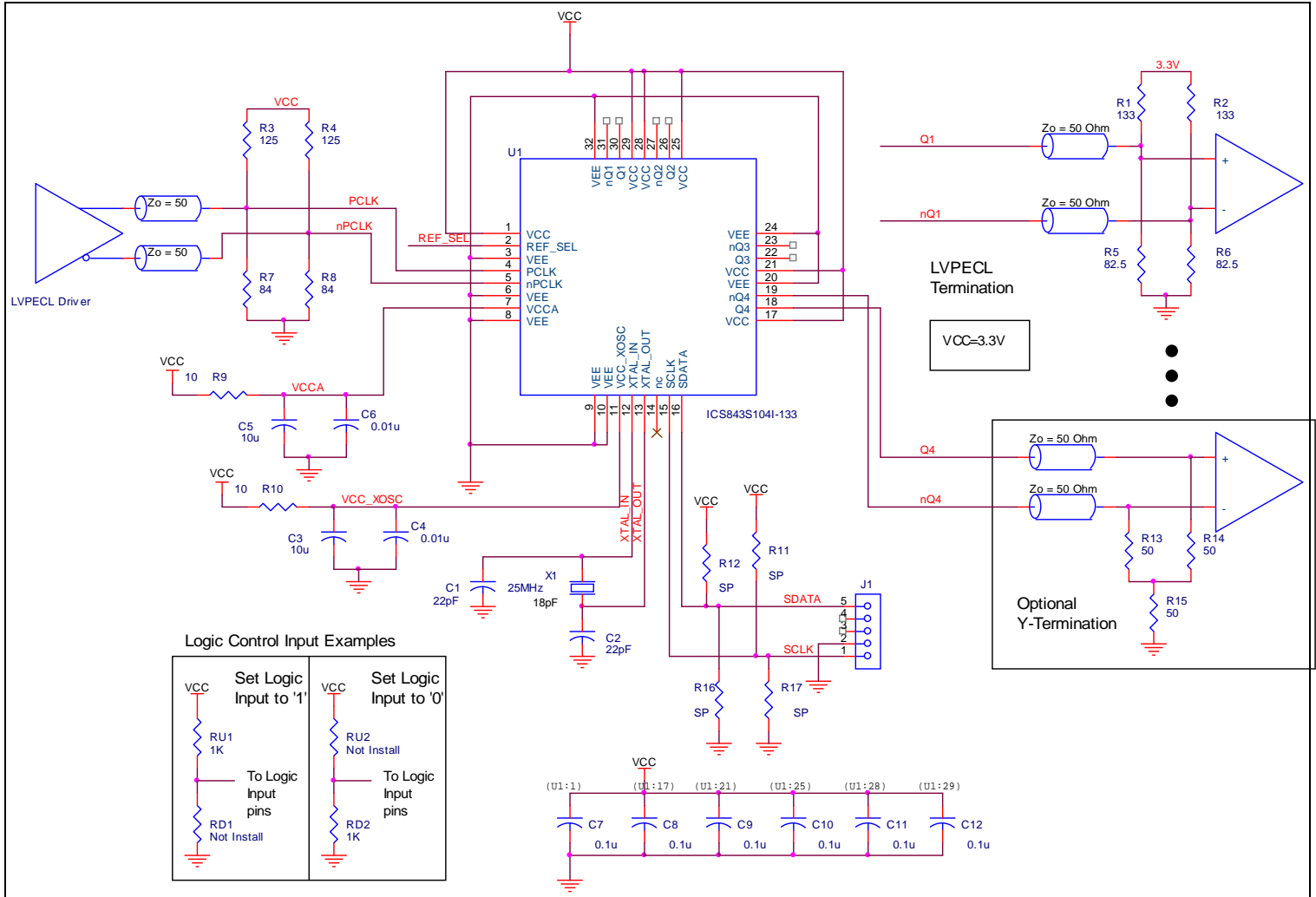

Figure 7. 843S104I-133 Schematic Layout

PCI Express Application Note

PCI Express jitter analysis methodology models the system response to reference clock jitter. The block diagram below shows the most frequently used *Common Clock Architecture* in which a copy of the reference clock is provided to both ends of the PCI Express Link.

In the jitter analysis, the transmit (Tx) and receive (Rx) serdes PLLs are modeled as well as the phase interpolator in the receiver. These transfer functions are called H1, H2, and H3 respectively. The overall system transfer function at the receiver is:

$$H_t(s) = H_3(s) \times [H_1(s) - H_2(s)]$$

The jitter spectrum seen by the receiver is the result of applying this system transfer function to the clock spectrum X(s) and is:

$$Y(s) = X(s) \times H_3(s) \times [H_1(s) - H_2(s)]$$

In order to generate time domain jitter numbers, an inverse Fourier Transform is performed on $X(s) \times H_3(s) \times [H_1(s) - H_2(s)]$.

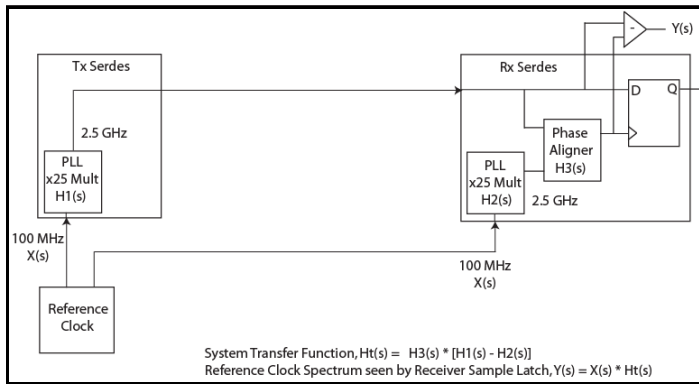

PCI Express Common Clock Architecture

For **PCI Express Gen 1**, one transfer function is defined and the evaluation is performed over the entire spectrum: DC to Nyquist (e.g for a 100MHz reference clock: 0Hz – 50MHz) and the jitter result is reported in peak-peak.

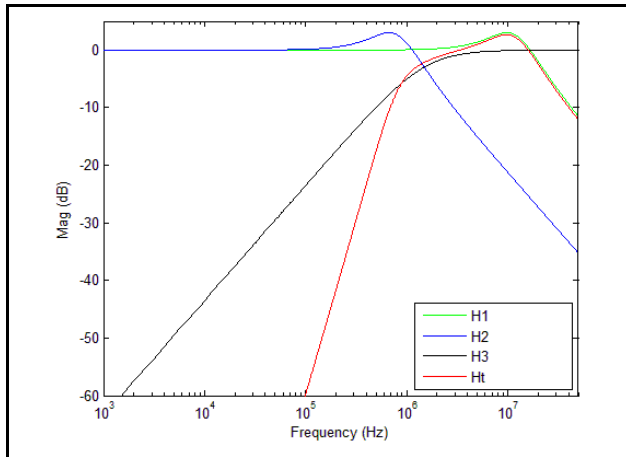

PCI Express Gen 1 Magnitude of Transfer Function

For **PCI Express Gen 2**, two transfer functions are defined with 2 evaluation ranges and the final jitter number is reported in rms. The two evaluation ranges for PCI Express Gen 2 are 10kHz – 1.5MHz (Low Band) and 1.5MHz – Nyquist (High Band). The plots show the individual transfer functions as well as the overall transfer function Ht.

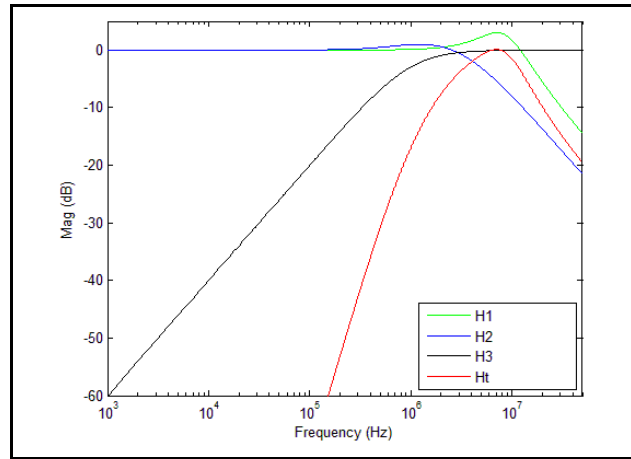

PCI Express Gen 2A Magnitude of Transfer Function

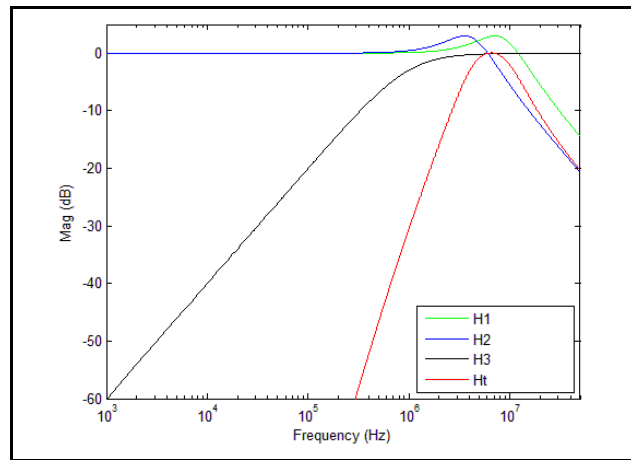

PCI Express Gen 2B Magnitude of Transfer Function

For **PCI Express Gen 3**, one transfer function is defined and the evaluation is performed over the entire spectrum. The transfer function parameters are different from Gen 1 and the jitter result is reported in RMS.

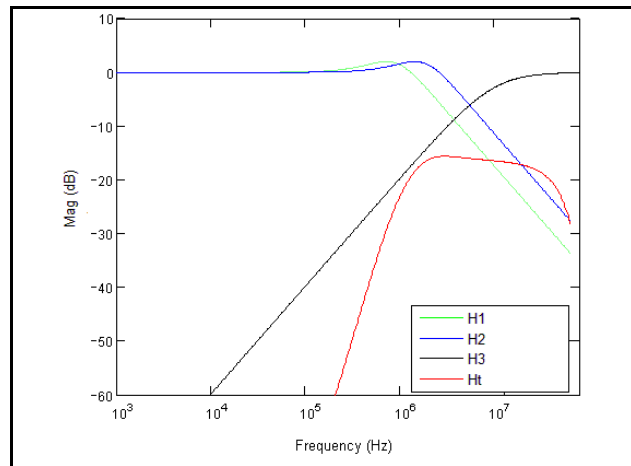

PCI Express Gen 3 Magnitude of Transfer Function

For a more thorough overview of PCI Express jitter analysis methodology, please refer to IDT Application Note *PCI Express Reference Clock Requirements*.

Power Considerations

This section provides information on power dissipation and junction temperature for the 843S104I-133. Equations and example calculations are also provided.

1. Power Dissipation.

The total power dissipation for the 843S104I-133 is the sum of the core power plus the power dissipated in the load(s). The following is the power dissipation for $V_{CC} = 3.3V + 5\% = 3.465V$, which gives worst case results.

NOTE: Please refer to Section 3 for details on calculating power dissipated in the load.

- Power (core)_{MAX} = $V_{CC_MAX} * I_{EE_MAX} = 3.465V * 130mA = 450.45mW$
- Power (outputs)_{MAX} = **32mW/Loaded Output pair**
If all outputs are loaded, the total power is $4 * 32mW = 128mW$

Total Power_{MAX} (3.3V, with all outputs switching) = $450.45mW + 128mW = 578.45mW$

2. Junction Temperature.

Junction temperature, T_j , is the temperature at the junction of the bond wire and bond pad directly affects the reliability of the device. The maximum recommended junction temperature is 125°C. Limiting the internal transistor junction temperature, T_j , to 125°C ensures that the bond wire and bond pad temperature remains below 125°C.

The equation for T_j is as follows: $T_j = \theta_{JA} * Pd_total + T_A$

T_j = Junction Temperature

θ_{JA} = Junction-to-Ambient Thermal Resistance

Pd_total = Total Device Power Dissipation (example calculation is in section 1 above)

T_A = Ambient Temperature

In order to calculate junction temperature, the appropriate junction-to-ambient thermal resistance θ_{JA} must be used. Assuming no air flow and a multi-layer board, the appropriate value is 39.5°C/W per Table 7 below.

Therefore, T_j for an ambient temperature of 85°C with all outputs switching is:

$$85^\circ C + 0.578W * 39.5^\circ C/W = 107.8^\circ C. \text{ This is below the limit of } 125^\circ C.$$

This calculation is only an example. T_j will obviously vary depending on the number of loaded outputs, supply voltage, air flow and the type of board (multi-layer).

Table 7. Thermal Resistance θ_{JA} for 32 Lead VFQFN, Forced Convection

θ_{JA} vs. Air Flow			
Meters per Second	0	1	2.5
Multi-Layer PCB, JEDEC Standard Test Boards	39.5°C/W	34.5°C/W	31.0°C/W

3. Calculations and Equations.

The purpose of this section is to derive the power dissipated into the load.

LVPECL output driver circuit and termination are shown in *Figure 8*.

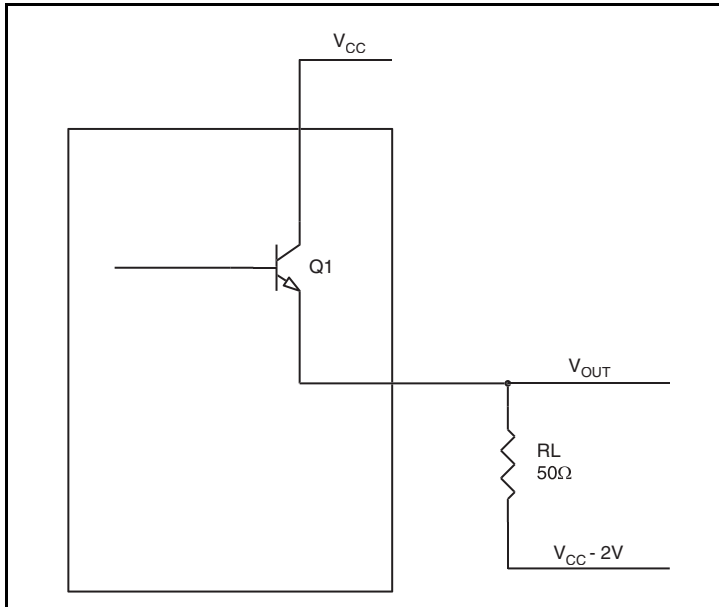

Figure 8. LVPECL Driver Circuit and Termination

To calculate worst case power dissipation into the load, use the following equations which assume a 50Ω load, and a termination voltage of $V_{CC} - 2V$.

- For logic high, $V_{OUT} = V_{OH_MAX} = V_{CC_MAX} - 0.8V$
 $(V_{CC_MAX} - V_{OH_MAX}) = 0.8V$
- For logic low, $V_{OUT} = V_{OL_MAX} = V_{CC_MAX} - 1.6V$
 $(V_{CC_MAX} - V_{OL_MAX}) = 1.6V$

Pd_H is power dissipation when the output drives high.

Pd_L is the power dissipation when the output drives low.

$$Pd_H = [(V_{OH_MAX} - (V_{CC_MAX} - 2V))/R_L] * (V_{CC_MAX} - V_{OH_MAX}) = [(2V - (V_{CC_MAX} - V_{OH_MAX}))/R_L] * (V_{CC_MAX} - V_{OH_MAX}) = [(2V - 0.8V)/50\Omega] * 0.8V = \mathbf{19.2mW}$$

$$Pd_L = [(V_{OL_MAX} - (V_{CC_MAX} - 2V))/R_L] * (V_{CC_MAX} - V_{OL_MAX}) = [(2V - (V_{CC_MAX} - V_{OL_MAX}))/R_L] * (V_{CC_MAX} - V_{OL_MAX}) = [(2V - 1.6V)/50\Omega] * 1.6V = \mathbf{12.8mW}$$

Total Power Dissipation per output pair = $Pd_H + Pd_L = \mathbf{32mW}$

Reliability Information

Table 8. θ_{JA} vs. Air Flow Table for a 32 Lead VFQFN

θ_{JA} vs. Air Flow			
Meters per Second	0	1	2.5
Multi-Layer PCB, JEDEC Standard Test Boards	39.5°C/W	34.5°C/W	31.0°C/W

Transistor Count

The transistor count for 843S104I-133 is: 11,927

Package Outline and Package Dimensions

Package Outline - K Suffix for 32 Lead VFQFN

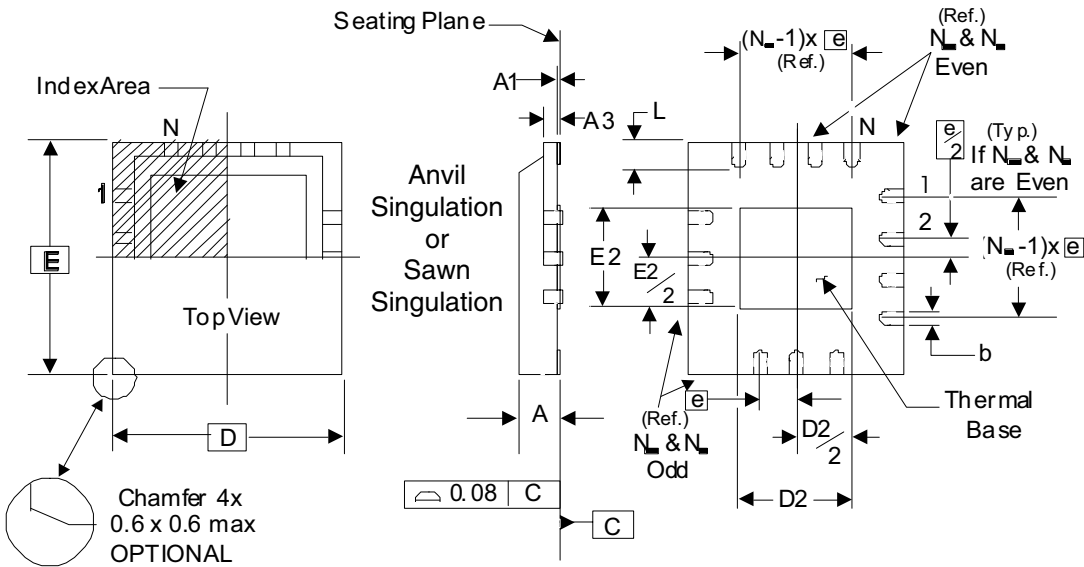

NOTE: The following package mechanical drawing is a generic drawing that applies to any pin count VFQFN package. This drawing is not intended to convey the actual pin count or pin layout of this device. The pin count and pinout are shown on the front page. The package dimensions are in Table 9 below.

Table 9. Package Dimensions

JEDEC Variation: VHHD-2/-4			
All Dimensions in Millimeters			
Symbol	Minimum	Nominal	Maximum
N	32		
A	0.80		1.00
A1	0		0.05
A3	0.25 Ref.		
b	0.18	0.25	0.30
N _D & N _E	8		
D & E	5.00 Basic		
D2 & E2	3.0		3.3
e	0.50 Basic		
L	0.30	0.40	0.50

Reference Document: JEDEC Publication 95, MO-220

Ordering Information

Table 10. Ordering Information

Part/Order Number	Marking	Package	Shipping Packaging	Temperature
843S104BKI-133LF	ICS04BI133L	"Lead-Free" 32 Lead VFQFN	Tray	-40°C to 85°C
843S104BKI-133LFT	ICS04BI133L	"Lead-Free" 32 Lead VFQFN	Tape & Reel	-40°C to 85°C

Revision History Sheet

Rev	Table	Page	Description of Change	Date
B	T10		Updated header/footer throughout the datasheet.	10/20/15
		11	Deleted <i>IDT</i> prefix from part number.	
		12	Application Information, updated:	
		14	Updated <i>Overdriving the XTAL Interface</i> ,	
		17	<i>Termination for 3.3V LVPECL Outputs</i>	
	22	<i>PCI Express Application Note</i>		
			Ordering Information Table - deleted Tape & Reel Count, and table note.	
B			Updated data sheet headers and footers.	4/28/16

IMPORTANT NOTICE AND DISCLAIMER

RENESAS ELECTRONICS CORPORATION AND ITS SUBSIDIARIES (“RENESAS”) PROVIDES TECHNICAL SPECIFICATIONS AND RELIABILITY DATA (INCLUDING DATASHEETS), DESIGN RESOURCES (INCLUDING REFERENCE DESIGNS), APPLICATION OR OTHER DESIGN ADVICE, WEB TOOLS, SAFETY INFORMATION, AND OTHER RESOURCES “AS IS” AND WITH ALL FAULTS, AND DISCLAIMS ALL WARRANTIES, EXPRESS OR IMPLIED, INCLUDING, WITHOUT LIMITATION, ANY IMPLIED WARRANTIES OF MERCHANTABILITY, FITNESS FOR A PARTICULAR PURPOSE, OR NON-INFRINGEMENT OF THIRD-PARTY INTELLECTUAL PROPERTY RIGHTS.

These resources are intended for developers who are designing with Renesas products. You are solely responsible for (1) selecting the appropriate products for your application, (2) designing, validating, and testing your application, and (3) ensuring your application meets applicable standards, and any other safety, security, or other requirements. These resources are subject to change without notice. Renesas grants you permission to use these resources only to develop an application that uses Renesas products. Other reproduction or use of these resources is strictly prohibited. No license is granted to any other Renesas intellectual property or to any third-party intellectual property. Renesas disclaims responsibility for, and you will fully indemnify Renesas and its representatives against, any claims, damages, costs, losses, or liabilities arising from your use of these resources. Renesas' products are provided only subject to Renesas' Terms and Conditions of Sale or other applicable terms agreed to in writing. No use of any Renesas resources expands or otherwise alters any applicable warranties or warranty disclaimers for these products.

(Disclaimer Rev.1.01)

Corporate Headquarters

TOYOSU FORESIA, 3-2-24 Toyosu,
Koto-ku, Tokyo 135-0061, Japan
www.renesas.com

Trademarks

Renesas and the Renesas logo are trademarks of Renesas Electronics Corporation. All trademarks and registered trademarks are the property of their respective owners.

Contact Information

For further information on a product, technology, the most up-to-date version of a document, or your nearest sales office, please visit www.renesas.com/contact-us/.