

### General Description

The ICS844S0258-07 is an eight output synthesizer optimized to generate Gigabit and 10 Gigabit Ethernet clocks. Using a 25MHz, 18pF parallel resonant crystal, the device will generate 125MHz clocks with mixed LVDS and LVCMOS/ LVTTTL output levels.

ICS844S0258-07 uses IDT's 3<sup>rd</sup> generation low phase noise VCO technology and can achieve <1ps typical RMS phase jitter, easily meeting Ethernet jitter requirements. ICS844S0258-07 is packaged in a small, 32-pin VFQFN package that is optimum for applications with space limitations.

### Features

- Seven LVDS differential output at 125MHz  
One LVCMOS/LVTTTL single-ended outputs at 125MHz
- Selectable crystal oscillator interface or LVCMOS/LVTTTL single-ended input and PLL bypass from a single select pin
- Output enable signal for three LVDS outputs
- RMS phase jitter @ 125MHz, using a 25MHz crystal (1.857MHz - 20MHz): 0.278ps (typical)
- PCI Express (2.5Gb/s) and Gen 2 (5 Gb/s) jitter compliant
- Full 3.3V supply mode
- 0°C to 70°C ambient operating temperature
- Lead-free (RoHS 6) packaging

### Pin Assignment

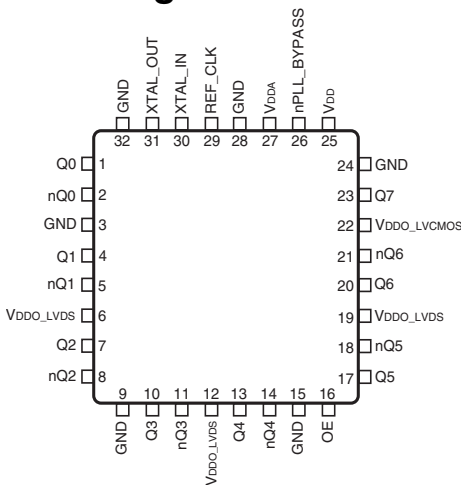

ICS844S0258-07

32-Lead VFQFN

5mm x 5mm x 0.925mm

package body

K Package

Top View

### Block Diagram

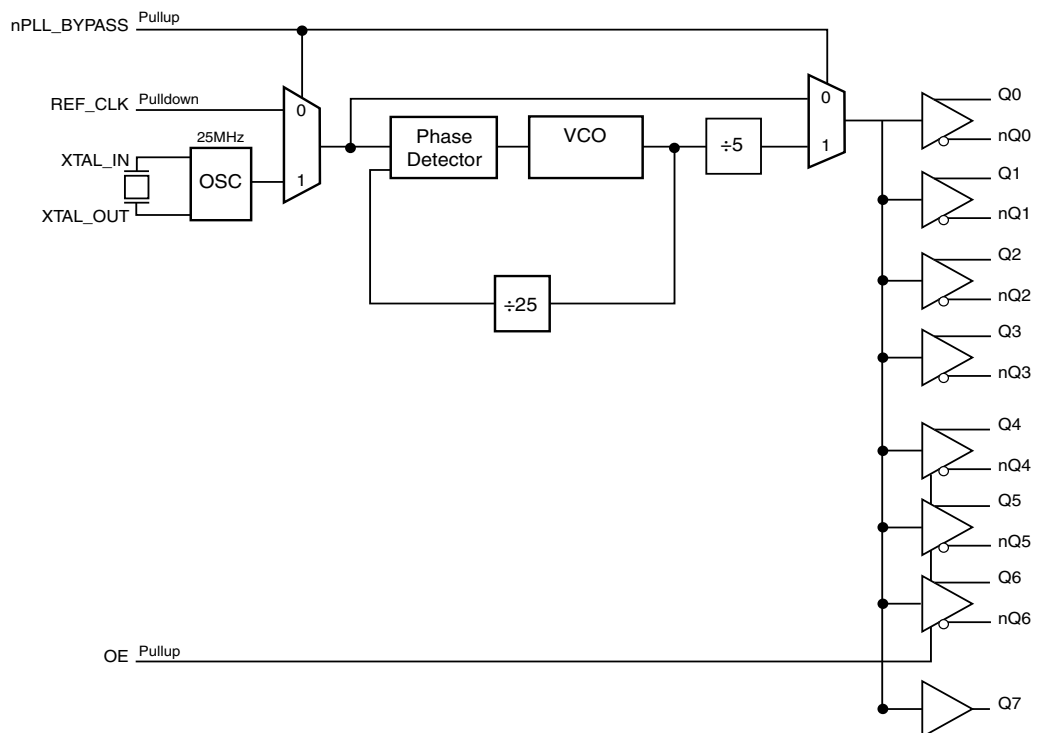

## Pin Descriptions and Characteristics

**Table 1. Pin Descriptions**

Number	Name	Type		Description
1, 2	Q0, nQ0	Output		Differential clock outputs. LVDS interface levels.
3, 9, 15, 24, 28, 32	GND	Power		Power supply ground.
4, 5	Q1, nQ1	Output		Differential clock outputs. LVDS interface levels.
6, 12, 19	V <sub>DDO_LVDS</sub>	Power		Output supply pins for differential LVDS outputs.
7, 8	Q2, nQ2	Output		Differential clock outputs. LVDS interface levels.
10, 11	Q3, nQ3	Output		Differential clock outputs. LVDS interface levels.
13, 14	Q4, nQ4	Output		Differential clock outputs. LVDS interface levels.
16	OE	Input	Pullup	Output enable pin for Q[4:6]/nQ[4:6] outputs. If connected to HIGH or left open, enables the outputs. When connected to LOW or GND, disables the outputs to high-impedance state. LVCMOS/LVTTL interface levels.
17, 18	Q5, nQ5	Output		Differential clock outputs. LVDS interface levels.
20, 21	Q6, nQ6	Output		Differential clock outputs. LVDS interface levels.
22	V <sub>DDO_LVCMOS</sub>	Power		Output supply pin for single-ended output.
23	Q7	Output		Single-ended clock output. LVCMOS/LVTTL levels.
25	V <sub>DD</sub>	Power		Core supply pin.
26	nPLL_BYPASS	Input	Pullup	Input select and PLL bypass control pin. See Table 3. LVCMOS/LVTTL interface levels.
27	V <sub>DDA</sub>	Power		Analog supply pin.
29	REF_CLK	Input	Pulldown	Single-ended reference clock input. Only selected in nPLL_BYPASS mode. LVCMOS/LVTTL interface levels.
30,31	XTAL_IN, XTAL_OUT	Input		Crystal oscillator interface. XTAL_OUT is the output, XTAL_IN is the input.

NOTE: *Pullup* and *Pulldown* refer to internal input resistors. See Table 2, *Pin Characteristics*, for typical values.

**Table 2. Pin Characteristics**

Symbol	Parameter	Test Conditions	Minimum	Typical	Maximum	Units
C <sub>IN</sub>	Input Capacitance			2		pF
C <sub>PD</sub>	Power Dissipation Capacitance	Q7 V <sub>DD</sub> , V <sub>DDO_LVCMOS</sub> = 3.465V		12		pF
R <sub>PULLUP</sub>	Input Pullup Resistor			51		kΩ
R <sub>PULLDOWN</sub>	Input Pulldown Resistor			51		kΩ
R <sub>OUT</sub>	Output Impedance	Q7		20		Ω

## Function Table

**Table 3. PLL Bypass and Input Select Function Table**

Inputs		
nPLL_BYPASS	PLL Bypass	Input Selected
0	PLL Bypassed	REF_CLK
1	PLL Enabled	XTAL_IN/XTAL_OUT

## Absolute Maximum Ratings

NOTE: Stresses beyond those listed under *Absolute Maximum Ratings* may cause permanent damage to the device. These ratings are stress specifications only. Functional operation of the product at these conditions or any conditions beyond those listed in the *DC Characteristics* or *AC Characteristics* is not implied. Exposure to absolute maximum rating conditions for extended periods may affect product reliability.

Item	Rating
Supply Voltage, $V_{DD}$	4.6V
Inputs, $V_I$ XTAL_IN Other Inputs	0V to $V_{DD}$ -0.5V to $V_{DD} + 0.5V$
Outputs, $I_O$ (LVCMOS)	-0.5V to $V_{DDO\_LVCMOS} + 0.5V$
Outputs, $I_O$ (LVDS) Continuous Current Surge Current	10mA 15mA
Operating Temperature Range, $T_A$	0°C to +70°C
Package Thermal Impedance, $\theta_{JA}$	39.5°C/W (0 mps)
Storage Temperature, $T_{STG}$	-65°C to 150°C

## DC Electrical Characteristics

**Table 4A. Power Supply DC Characteristics,  $V_{DD} = V_{DDO\_LVCMOS} = V_{DDO\_LVDS} = 3.3V \pm 5\%$ ,  $T_A = 0^\circ\text{C}$  to  $70^\circ\text{C}$**

Symbol	Parameter	Test Conditions	Minimum	Typical	Maximum	Units
$V_{DD}$	Core Supply Voltage		3.135	3.3	3.465	V
$V_{DDA}$	Analog Supply Voltage		$V_{DD} - 0.20$	3.3	$V_{DD}$	V
$V_{DDO\_LVCMOS}$ $V_{DDO\_LVDS}$	Output Supply Voltage		3.135	3.3	3.465	V
$I_{DD}$	Power Supply Current				80	mA
$I_{DDA}$	Analog Supply Current				20	mA
$I_{DDO\_LVCMOS}$ , $I_{DDO\_LVDS}$	Power Supply Current				120	mA

NOTE: The device has a power sequence requirement, refer to the Applications Section.

**Table 4B. LVCMOS/LVTTL DC Characteristics,  $V_{DD} = V_{DDO\_LVCMOS} = 3.3V \pm 5\%$ ,  $T_A = 0^\circ\text{C}$  to  $70^\circ\text{C}$**

Symbol	Parameter	Test Conditions	Minimum	Typical	Maximum	Units
$V_{IH}$	Input High Voltage		2.2		$V_{DD} + 0.3$	V
$V_{IL}$	Input Low Voltage		-0.3		0.8	V
$I_{IH}$	Input High Current	REF_CLK	$V_{DD} = V_{IN} = 3.465V$		150	$\mu\text{A}$
		OE, nPLL_BYPASS	$V_{DD} = V_{IN} = 3.465V$		10	$\mu\text{A}$
$I_{IL}$	Input Low Current	REF_CLK	$V_{DD} = 3.465V$ , $V_{IN} = 0V$	-10		$\mu\text{A}$
		OE, nPLL_BYPASS	$V_{DD} = 3.465V$ , $V_{IN} = 0V$	-150		$\mu\text{A}$
$V_{OH}$	Output High Voltage	Q7	$V_{DDO\_LVCMOS} = 3.3V \pm 5\%$	2.6		V
$V_{OL}$	Output Low Voltage	Q7	$V_{DDO\_LVCMOS} = 3.3V \pm 5\%$		0.5	V

**Table 4C. LVDS DC Characteristics,  $V_{DD} = V_{DDO\_LVDS} = 3.3V \pm 5\%$ ,  $T_A = 0^\circ C$  to  $70^\circ C$** 

Symbol	Parameter	Test Conditions	Minimum	Typical	Maximum	Units
$V_{OD}$	Differential Output Voltage		300	400	525	mV
$\Delta V_{OD}$	$V_{OD}$ Magnitude Change				50	mV
$V_{OS}$	Offset Voltage		1.15	1.30	1.45	V
$\Delta V_{OS}$	$V_{OS}$ Magnitude Change				50	mV

**Table 5. Crystal Characteristics**

Parameter	Test Conditions	Minimum	Typical	Maximum	Units
Mode of Oscillation			Fundamental		
Frequency			25		MHz
Equivalent Series Resistance				50	$\Omega$
Shunt Capacitance				7	pF

**Table 6. AC Characteristics,  $V_{DD} = V_{DDO\_LVCMOS} = V_{DDO\_LVDS} = 3.3V \pm 5\%$ ,  $T_A = 0^\circ C$  to  $70^\circ C$** 

Symbol	Parameter	Test Conditions	Minimum	Typical	Maximum	Units
$f_{out}$	Output Frequency			125		MHz
$f_{jit}(\emptyset)$	RMS Phase Noise Jitter; NOTE 1	LVDS	125MHz, Integration Range: 1.857MHz - 20MHz	0.278		ps
		LVCMOS	125MHz, Integration Range: 1.857MHz - 20MHz	0.284		ps
$t_j$	Phase Jitter Peak-to-Peak; NOTE 2	125MHz, (1.2MHz – 21.9MHz), Evaluation Band: 0Hz - Nyquist (clock frequency/2)		8.57		ps
$t_{REFCLK\_HF\_RMS}$	Phase Jitter RMS; NOTE 3	125MHz, 25MHz crystal input High Band: 1.5MHz - Nyquist (clock frequency/2)		0.86		ps
$t_{REFCLK\_LF\_RMS}$	Phase Jitter RMS; NOTE 3	125MHz, 25MHz crystal input Low Band: 10kHz - 1.5MHz		0.12		ps
$t_R / t_F$	Output Rise/Fall Time	Q[0:6]: nQ[0:6]	30% to 70%, 15pF Load	70	650	ps
		Q7	20% to 80%	400	900	ps
odc	Output Duty Cycle		48		52	%
odc	Output Duty Cycle, Bypass Mode		45		55	%

NOTE: Electrical parameters are guaranteed over the specified ambient operating temperature range, which is established when the device is mounted in a test socket with maintained transverse airflow greater than 500 lpm. The device will meet specifications after thermal equilibrium has been reached under these conditions.

NOTE 1: Refer to Phase Noise Plots.

NOTE 2: Peak-to-Peak jitter after applying system transfer function for the Common Clock Architecture. Maximum limit for PCI Express Gen 1 is 86ps peak-to-peak for a sample size of  $10^6$  clock periods. See IDT Application Note *PCI Express Reference Clock Requirements* and also the PCI Express Application section of this datasheet which show each individual transfer function and the overall composite transfer function.

NOTE 3: RMS jitter after applying the two evaluation bands to the two transfer functions defined in the Common Clock Architecture and reporting the worst case results for each evaluation band. Maximum limit for PCI Express Generation 2 is 3.1ps rms for  $t_{REFCLK\_HF\_RMS}$  (High Band) and 3.0ps RMS for  $t_{REFCLK\_LF\_RMS}$  (Low Band). See IDT Application Note *PCI Express Reference Clock Requirements* and also the PCI Express Application section of this datasheet which show each individual transfer function and the overall composite transfer function.

## Typical Phase Noise at 125MHz (LVDS)

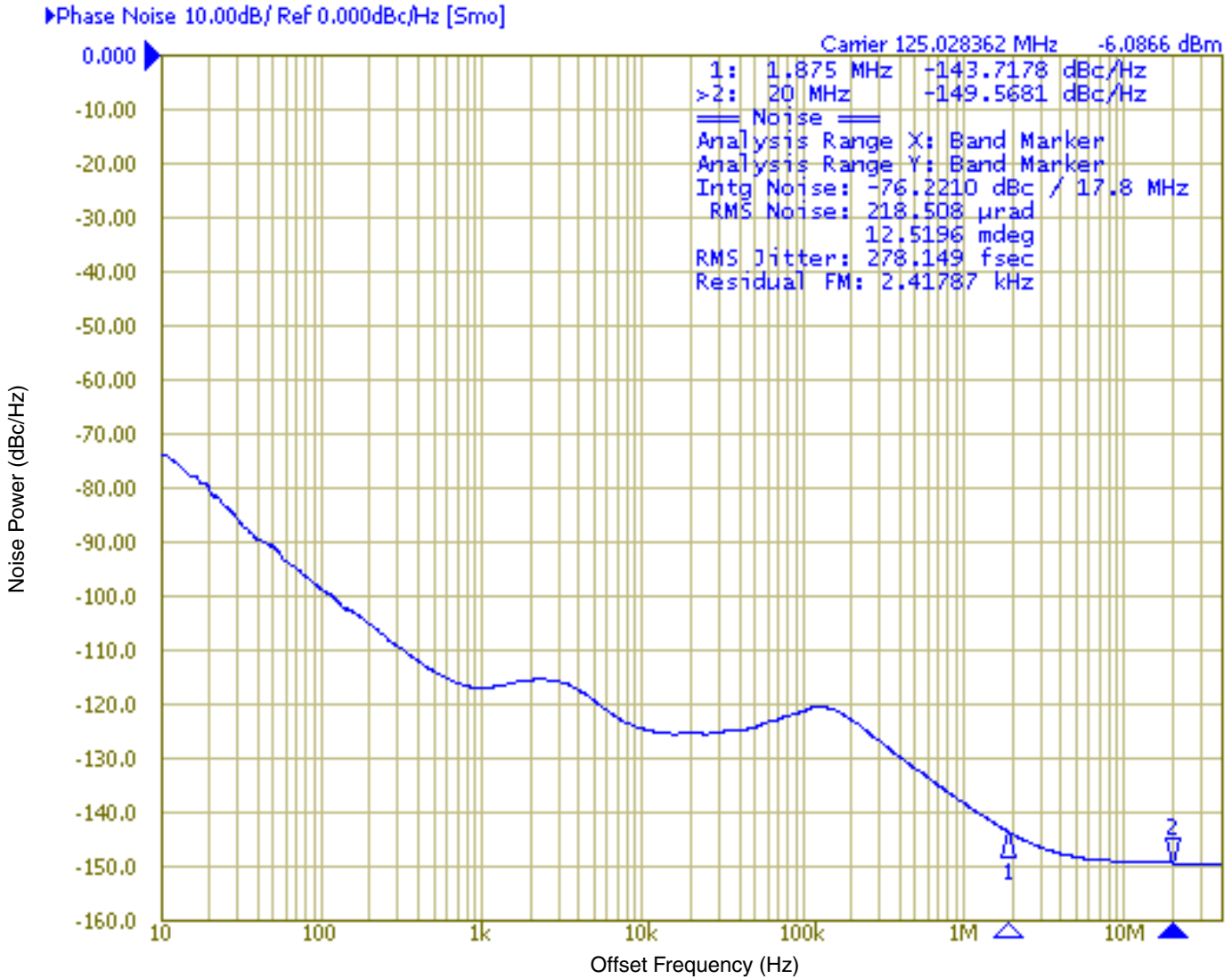

## Typical Phase Noise at 125MHz (LVCMOS)

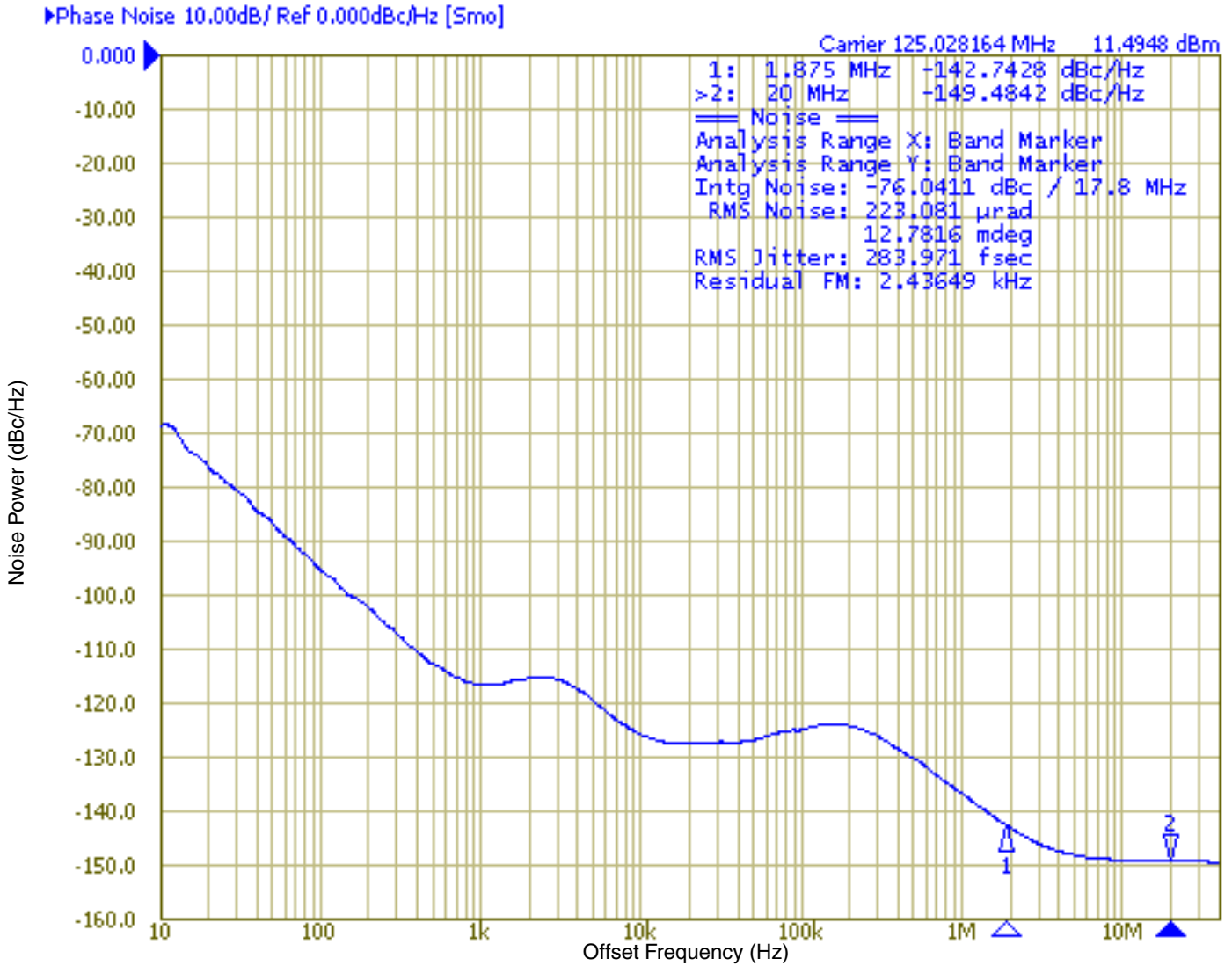

## Parameter Measurement Information

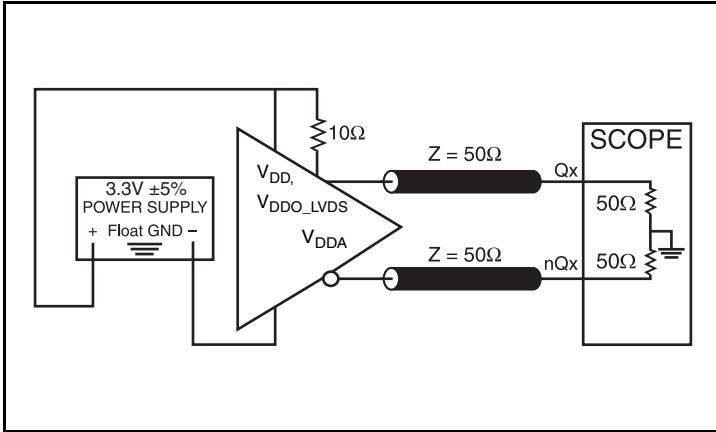

3.3V LVDS Output Load AC Test Circuit

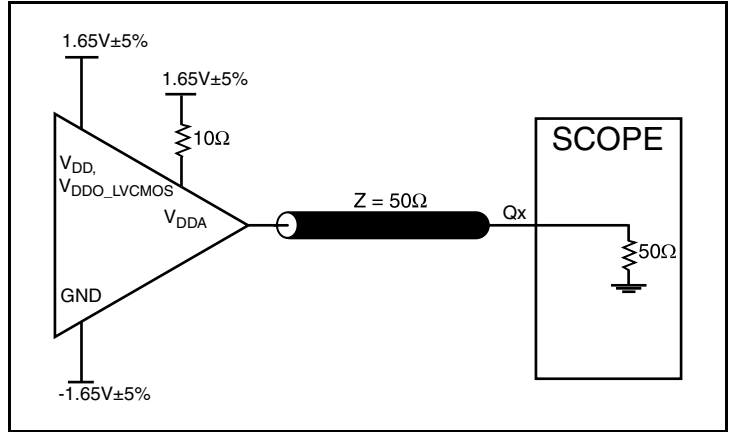

3.3V LVCMOS Output Load AC Test Circuit

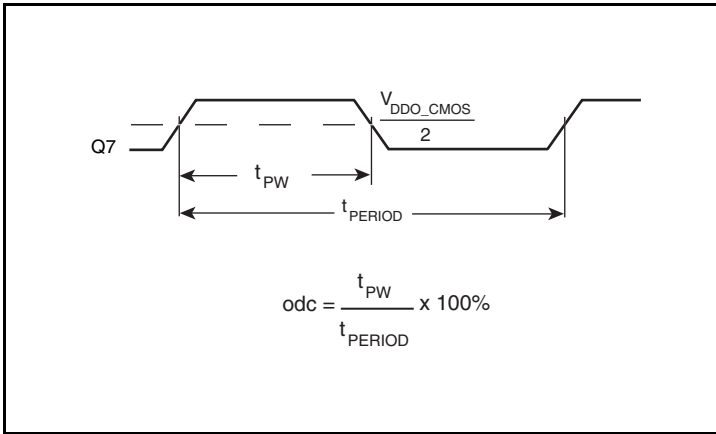

Single-Ended Output Duty Cycle/Pulse Width/Period

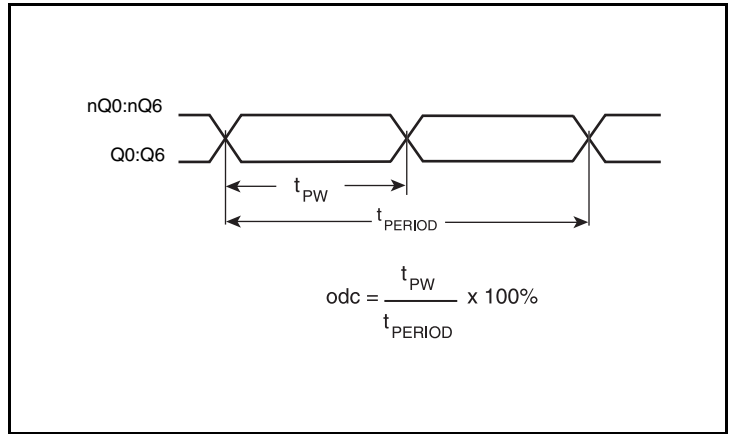

Differential Output Duty Cycle/Pulse Width/Period

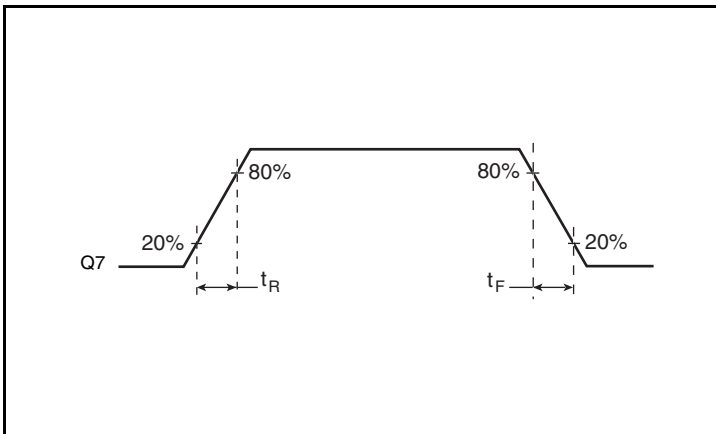

LVCMOS Output Rise/Fall Time

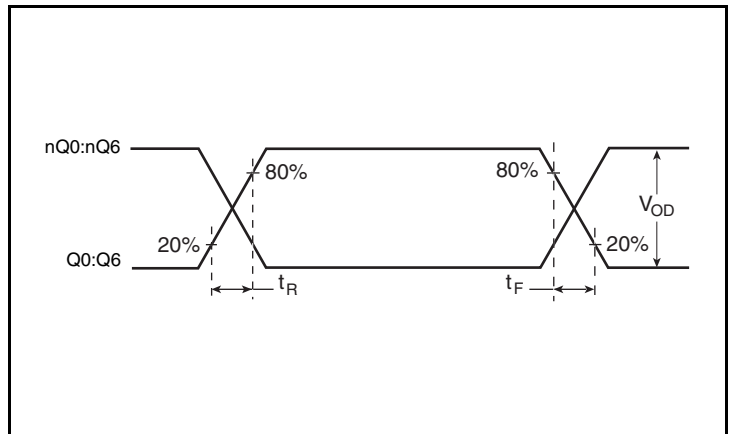

LVDS Output Rise/Fall Time

## Parameter Measurement Information, continued

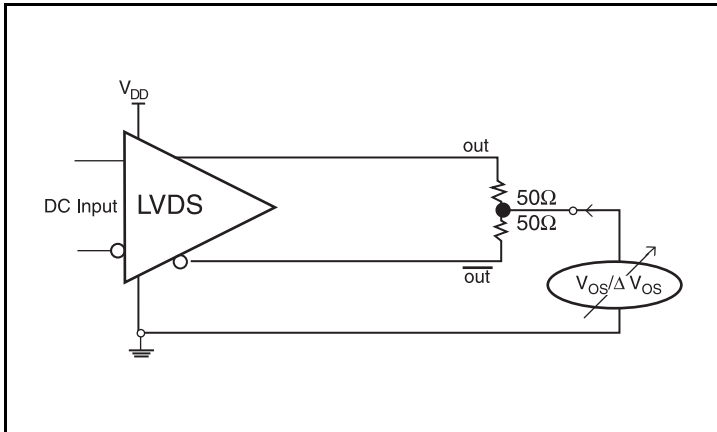

Offset Voltage Setup

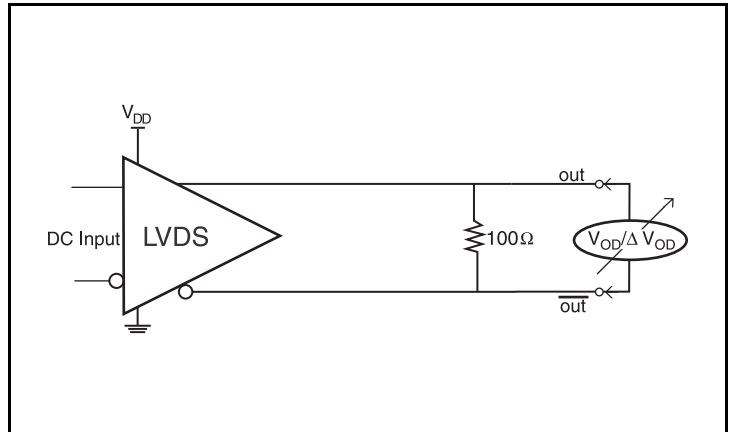

Differential Output Duty Cycle/Pulse Width/Period

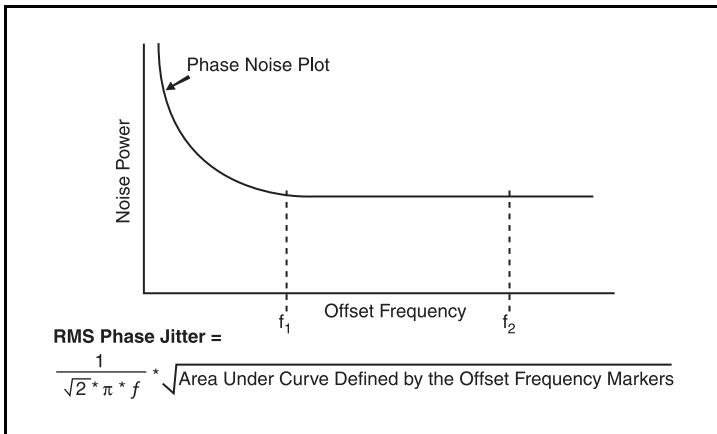

RMS Phase Jitter

## Applications Information

### Power Supply Filtering Technique

As in any high speed analog circuitry, the power supply pins are vulnerable to random noise. To achieve optimum jitter performance, power supply isolation is required. The ICS844S0258-07 provides separate power supplies to isolate any high switching noise from the outputs to the internal PLL.  $V_{DD}$ ,  $V_{DDA}$ ,  $V_{DDO\_LVDS}$  and  $V_{DDO\_LVCMOS}$  should be individually connected to the power supply plane through vias, and  $0.01\mu\text{F}$  bypass capacitors should be used for each pin. *Figure 1* illustrates this for a generic  $V_{DD}$  pin and also shows that  $V_{DDA}$  requires that an additional  $10\Omega$  resistor along with a  $10\mu\text{F}$  bypass capacitor be connected to the  $V_{DDA}$  pin.

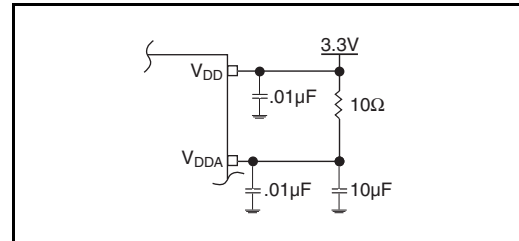

Figure 1. Power Supply Filtering

### Power Supply Sequence Requirement

The ICS844S0258-07 has a power supply sequence requirement. This device requires that  $V_{DD}$  and  $V_{DDA}$  are powered simultaneously. This device has been characterized using the recommended power supply filtering techniques in *Figure 1*.

#### Power Sequence:

1.  $V_{DD}$  and  $V_{DDA}$
2.  $V_{DDO\_LVCMOS}$  and  $V_{DDO\_LVDS}$

## Recommendations for Unused Input and Output Pins

### Inputs:

#### Crystal Inputs

For applications not requiring the use of the crystal oscillator input, both XTAL\_IN and XTAL\_OUT can be left floating. Though not required, but for additional protection, a  $1\text{k}\Omega$  resistor can be tied from XTAL\_IN to ground.

#### REF\_CLK Input

For applications not requiring the use of a reference clock input, it can be left floating. Though not required, but for additional protection, a  $1\text{k}\Omega$  resistor can be tied from the REF\_CLK input to ground.

#### LVCMOS Control Pins

All control pins have internal pullups or pulldowns; additional resistance is not required but can be added for additional protection. A  $1\text{k}\Omega$  resistor can be used.

### Outputs:

#### LVDS Outputs

All unused LVDS output pairs can be either left floating or terminated with  $100\Omega$  across. If they are left floating, there should be no trace attached.

#### LVCMOS Output

All unused LVCMOS output can be left floating. There should be no trace attached.

## Overdriving the XTAL Interface

The XTAL\_IN input can be overdriven by an LVCMOS driver or by one side of a differential driver through an AC coupling capacitor. The XTAL\_OUT pin can be left floating. The amplitude of the input signal should be between 500mV and 1.8V and the slew rate should not be less than 0.2V/nS. For 3.3V LVCMOS inputs, the amplitude must be reduced from full swing to at least half the swing in order to prevent signal interference with the power rail and to reduce internal noise. *Figure 2A* shows an example of the interface diagram for a high speed 3.3V LVCMOS driver. This configuration requires that the sum of the output impedance of the driver ( $R_o$ ) and the series resistance ( $R_s$ ) equals the transmission line impedance. In addition, matched termination at the crystal input will attenuate the signal in half. This

can be done in one of two ways. First,  $R_1$  and  $R_2$  in parallel should equal the transmission line impedance. For most 50Ω applications,  $R_1$  and  $R_2$  can be 100Ω. This can also be accomplished by removing  $R_1$  and changing  $R_2$  to 50Ω. The values of the resistors can be increased to reduce the loading for a slower and weaker LVCMOS driver. *Figure 2B* shows an example of the interface diagram for an LVPECL driver. This is a standard LVPECL termination with one side of the driver feeding the XTAL\_IN input. It is recommended that all components in the schematics be placed in the layout. Though some components might not be used, they can be utilized for debugging purposes. The datasheet specifications are characterized and guaranteed by using a quartz crystal as the input.

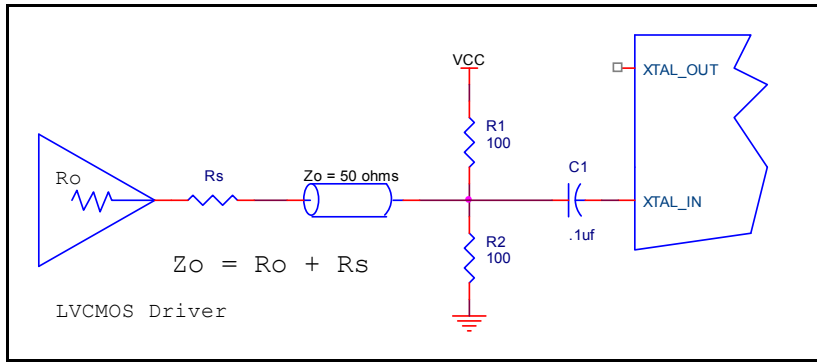

Figure 2A. General Diagram for LVCMOS Driver to XTAL Input Interface

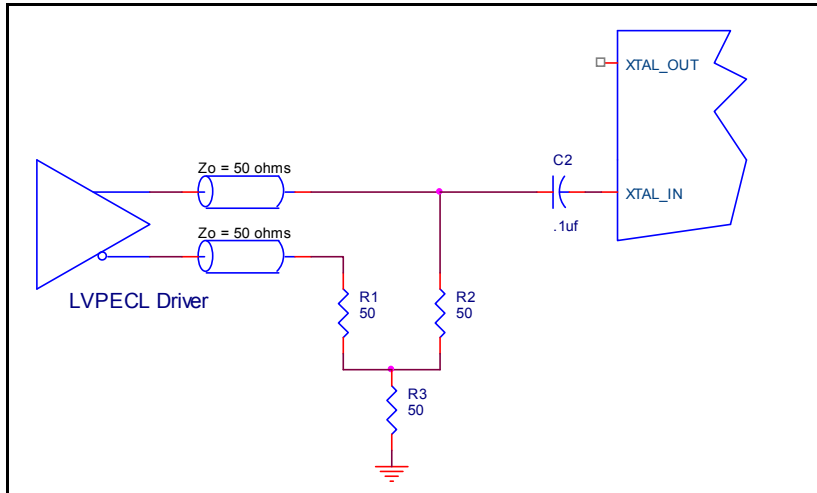
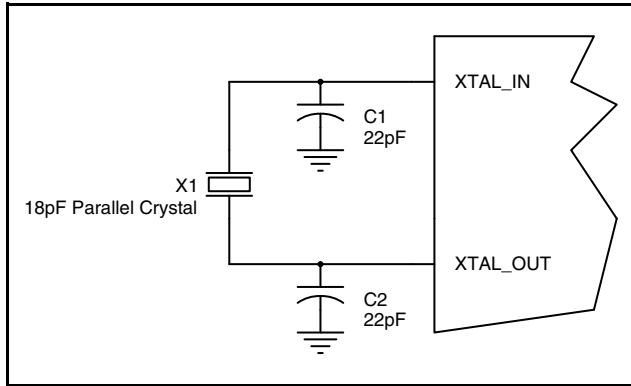

Figure 2B. General Diagram for LVPECL Driver to XTAL Input Interface

## Crystal Input Interface

The ICS844S0258-07 has been characterized with 18pF parallel resonant crystals. The capacitor values shown in *Figure 2* below

were determined using a 25MHz, 18pF parallel resonant crystal and were chosen to minimize the ppm error.

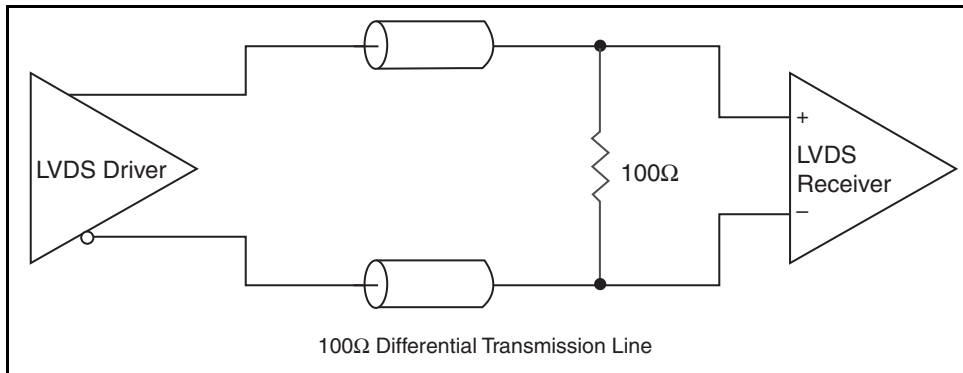

**Figure 2. Crystal Input Interface**

## LVDS Driver Termination

A general LVDS interface is shown in *Figure 4*. Standard termination for LVDS type output structure requires both a 100Ω parallel resistor at the receiver and a 100Ω differential transmission line environment. In order to avoid any transmission line reflection issues, the 100Ω resistor must be placed as close to the receiver as possible. IDT offers a full line of LVDS compliant devices with two types of output structures: current source and voltage source. The standard

termination schematic as shown in *Figure 4* can be used with either type of output structure. If using a non-standard termination, it is recommended to contact IDT and confirm if the output is a current source or a voltage source type structure. In addition, since these outputs are LVDS compatible, the input receivers amplitude and common mode input range should be verified for compatibility with the output.



**Figure 4. Typical LVDS Driver Termination**

## VFQFN EPAD Thermal Release Path

In order to maximize both the removal of heat from the package and the electrical performance, a land pattern must be incorporated on the Printed Circuit Board (PCB) within the footprint of the package corresponding to the exposed metal pad or exposed heat slug on the package, as shown in *Figure 5*. The solderable area on the PCB, as defined by the solder mask, should be at least the same size/shape as the exposed pad/slug area on the package to maximize the thermal/electrical performance. Sufficient clearance should be designed on the PCB between the outer edges of the land pattern and the inner edges of pad pattern for the leads to avoid any shorts.

While the land pattern on the PCB provides a means of heat transfer and electrical grounding from the package to the board through a solder joint, thermal vias are necessary to effectively conduct from the surface of the PCB to the ground plane(s). The land pattern must be connected to ground through these vias. The vias act as “heat pipes”. The number of vias (i.e. “heat pipes”) are application specific

and dependent upon the package power dissipation as well as electrical conductivity requirements. Thus, thermal and electrical analysis and/or testing are recommended to determine the minimum number needed. Maximum thermal and electrical performance is achieved when an array of vias is incorporated in the land pattern. It is recommended to use as many vias connected to ground as possible. It is also recommended that the via diameter should be 12 to 13mils (0.30 to 0.33mm) with 1oz copper via barrel plating. This is desirable to avoid any solder wicking inside the via during the soldering process which may result in voids in solder between the exposed pad/slug and the thermal land. Precautions should be taken to eliminate any solder voids between the exposed heat slug and the land pattern. Note: These recommendations are to be used as a guideline only. For further information, please refer to the Application Note on the Surface Mount Assembly of Amkor’s Thermally/Electrically Enhance Leadframe Base Package, Amkor Technology.

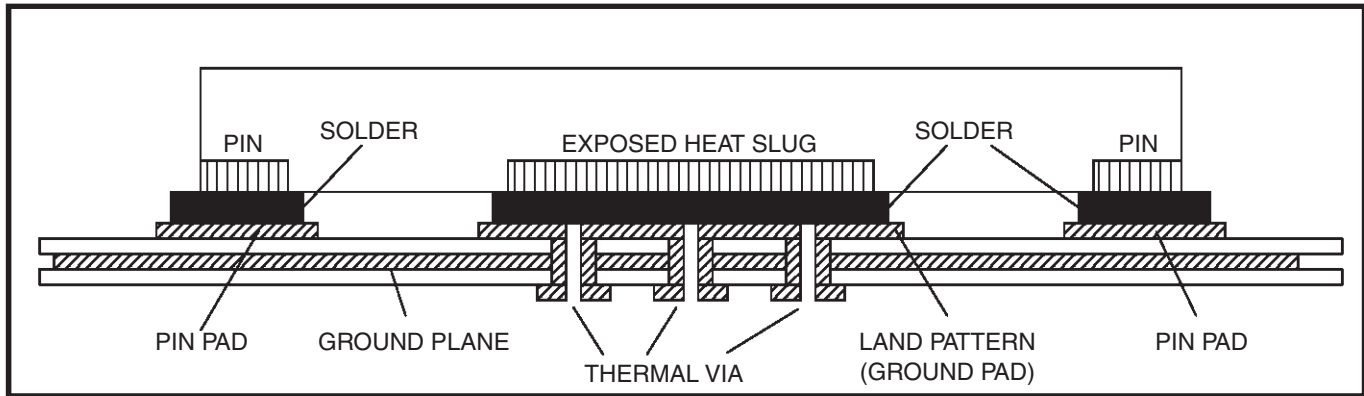

**Figure 5. P.C. Assembly for Exposed Pad Thermal Release Path – Side View (drawing not to scale)**

### Schematic Example

Figure 6 shows an example of ICS844S0258-07 application schematic. In this example, the device is operated at  $V_{DD} = V_{DDO\_LVDS} = V_{DDO\_LVCMOS} = 3.3V$ . The 18pF parallel resonant 25MHz crystal is used. The  $C1 = 22pF$  and  $C2 = 22pF$  are recommended for frequency accuracy. For different board layouts,

the  $C1$  and  $C2$  may be slightly adjusted for optimizing frequency accuracy. Two examples of LVDS for receiver without built-in termination and one example of LVCMOS are shown in this schematic.

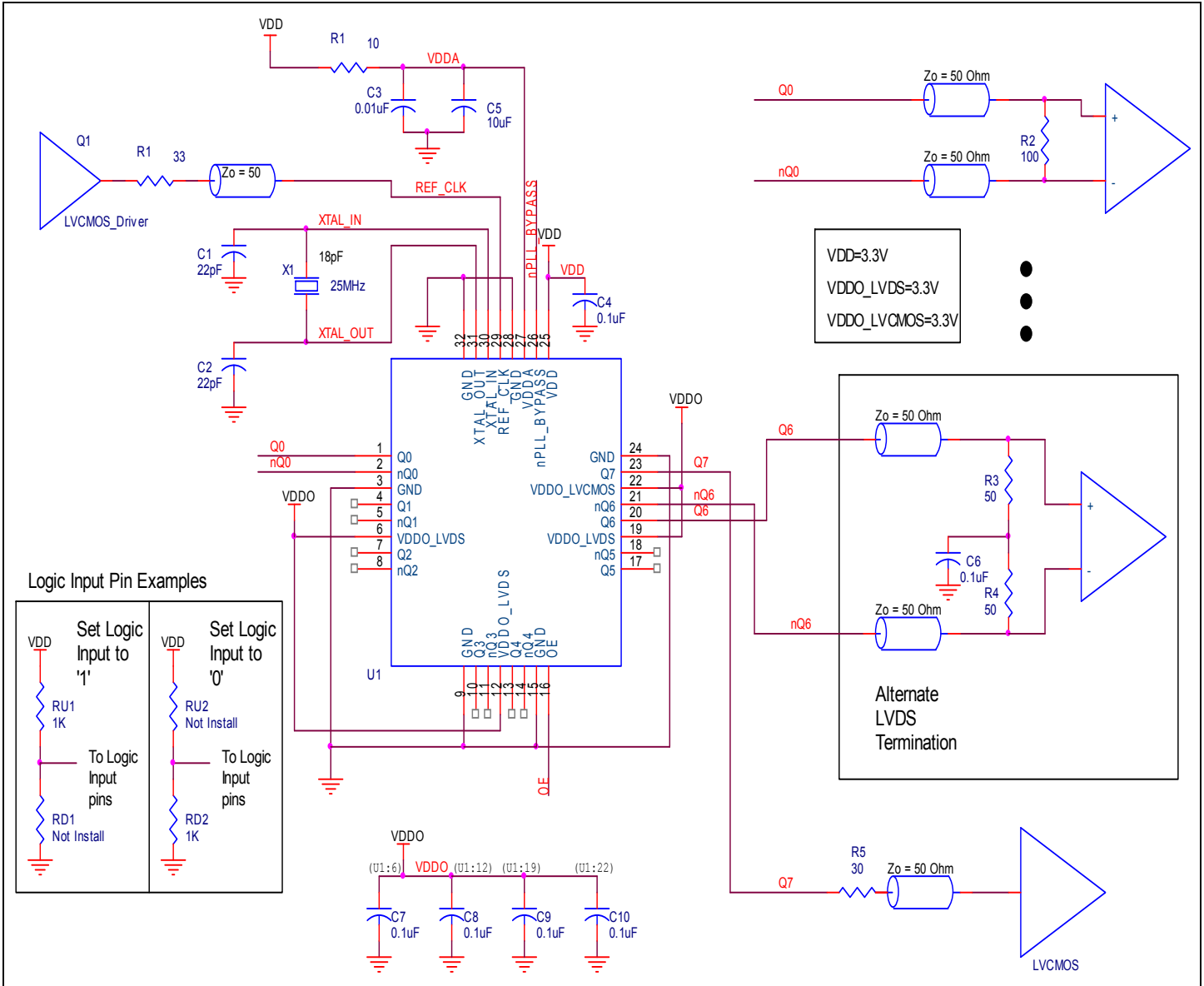
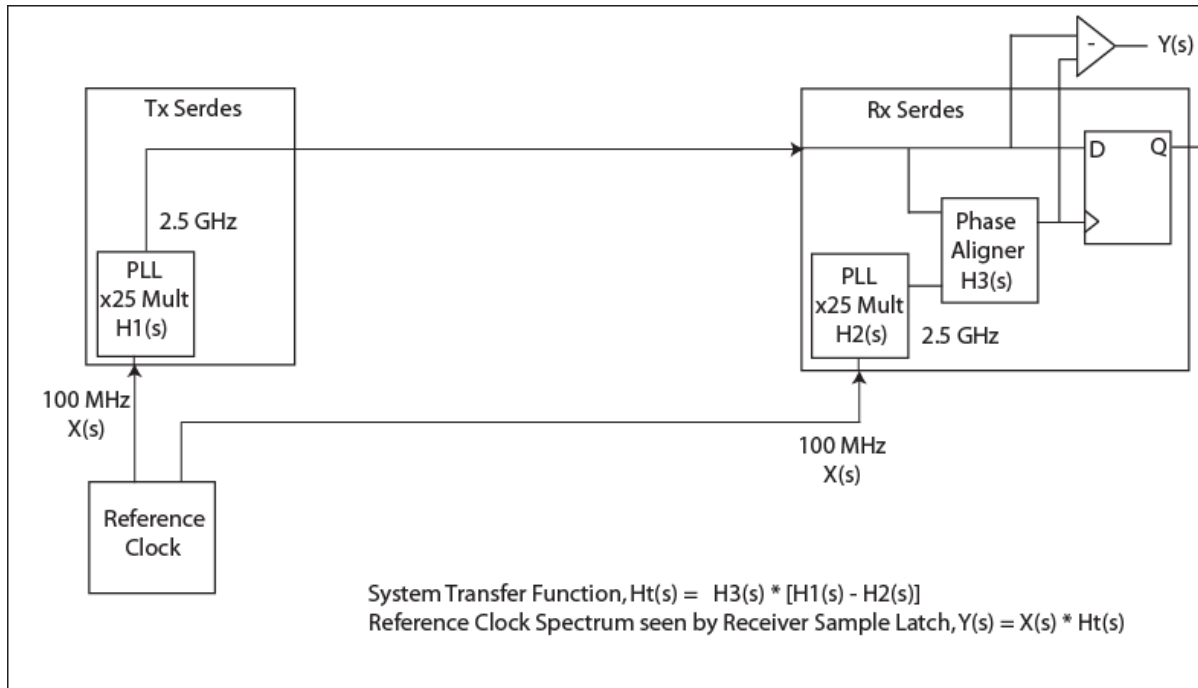

Figure 6. ICS844S0258-07 Schematic Example

## PCI Express Application Note

PCI Express jitter analysis methodology models the system response to reference clock jitter. The below block diagram shows the

most frequently used *Common Clock Architecture* in which a copy of the reference clock is provided to both ends of the PCI Express Link.



In the jitter analysis, the Tx and Rx serdes PLLs are modeled as well as the phase interpolator in the receiver. These transfer functions are called H1, H2, and H3 respectively. The overall system transfer function at the receiver is:

$$H_t(s) = H_3(s) \times [H_1(s) - H_2(s)]$$

The jitter spectrum seen by the receiver is the result of applying this system transfer function to the clock spectrum X(s) and is:

$$Y(s) = X(s) \times H_3(s) \times [H_1(s) - H_2(s)]$$

In order to generate time domain jitter numbers, an inverse Fourier Transform is performed on  $X(s) * H_3(s) * [H_1(s) - H_2(s)]$ .

For PCI Express Gen 1, one transfer function is defined and the evaluation is performed over the entire spectrum: DC to Nyquist (e.g for a 100MHz reference clock: 0Hz to 50MHz) and the jitter result is reported in peak-peak. For PCI Express Gen 2, two transfer functions are defined with 2 evaluation ranges and the final jitter number is reported in rms. The two evaluation ranges for PCI Express Gen 2 are 10kHz - 1.5MHz (Low Band) and 1.5MHz - Nyquist (High Band). The below plots show the individual transfer functions as well as the overall transfer function Ht. The respective -3 dB pole frequencies for each transfer function are labeled as F1 for transfer function H1, F2 for H2, and F3 for H3. For a more thorough overview of PCI Express jitter analysis methodology, please refer to IDT Application Note *PCI Express Reference Clock Requirements*.

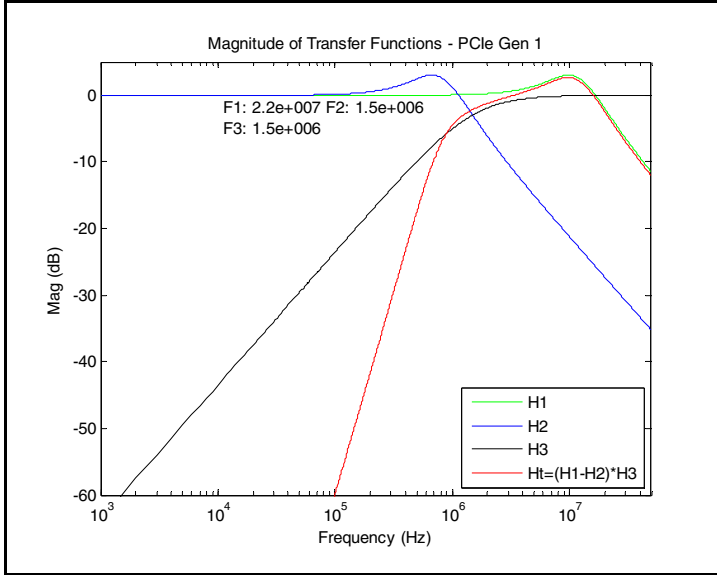

PCIe Gen 1 Magnitude of Transfer Function

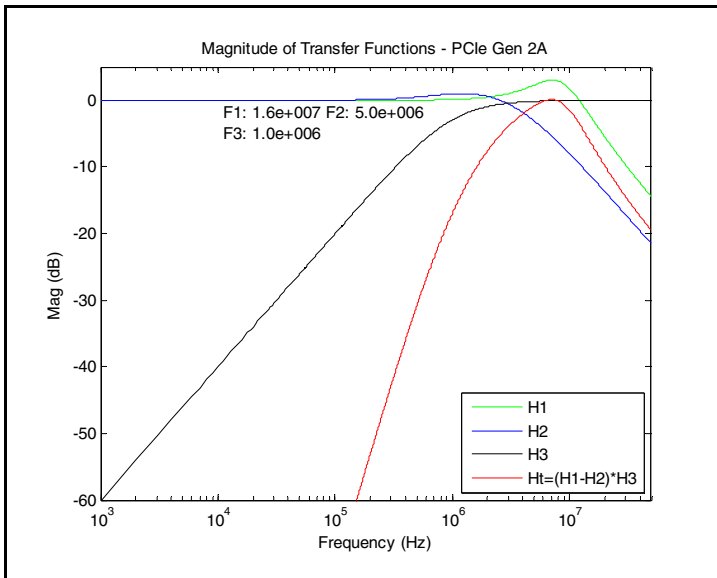

PCIe Gen 2A Magnitude of Transfer Function

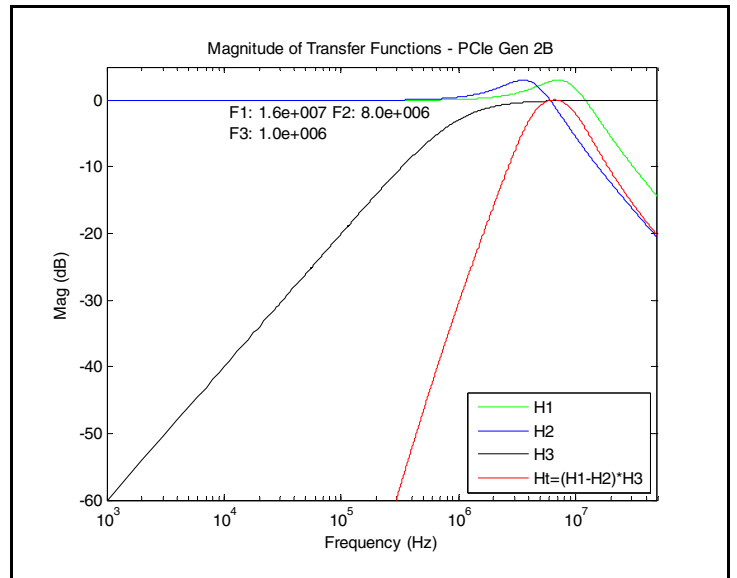

PCIe Gen 2B Magnitude of Transfer Function

## Power Considerations

This section provides information on power dissipation and junction temperature for the ICS844S0258-07. Equations and example calculations are also provided.

### 1. Power Dissipation.

The total power dissipation for the ICS44S0258-07 is the sum of the core power plus the analog plus the power dissipated in the load(s). The following is the power dissipation for  $V_{DD} = 3.3V + 5\% = 3.465V$ , which gives worst case results.

#### Core and LVDS Output Power Dissipation

- Power (core, LVDS) =  $V_{DD\_MAX} * (I_{DD} + I_{DDO\_LVDS} + I_{DDA}) = 3.465V * (80mA + 120mA + 20mA) = \mathbf{762.3mW}$

#### LVC MOS Output Power Dissipation

- Output Impedance  $R_{OUT}$  Power Dissipation due to Loading  $50\Omega$  to  $V_{DDO}/2$   
Output Current  $I_{OUT} = V_{DDO\_MAX} / [2 * (50\Omega + R_{OUT})] = 3.465V / [2 * (50\Omega + 20\Omega)] = \mathbf{24.75mA}$
- Power Dissipation on the  $R_{OUT}$  per LVC MOS output  
Power ( $R_{OUT}$ ) =  $R_{OUT} * (I_{OUT})^2 = 20\Omega * (24.75mA)^2 = \mathbf{12.25mW}$  per output
- Dynamic Power Dissipation at 125MHz  
Power (125MHz) =  $C_{PD} * Frequency * (V_{DDO})^2 = 12pF * 125MHz * (3.465V)^2 = \mathbf{18.01mW}$  per output

#### Total Power Dissipation

- Total Power**  
= Power (core, LVDS) + Power ( $R_{OUT}$ ) + Power (125MHz)  
=  $762.3mW + 12.25mW + 18.01mW$   
= **792.56mW**

### 2. Junction Temperature.

Junction temperature,  $T_j$ , is the temperature at the junction of the bond wire and bond pad directly affects the reliability of the device. The maximum recommended junction temperature is  $125^\circ C$ . Limiting the internal transistor junction temperature,  $T_j$ , to  $125^\circ C$  ensures that the bond wire and bond pad temperature remains below  $125^\circ C$ .

The equation for  $T_j$  is as follows:  $T_j = \theta_{JA} * Pd\_total + T_A$

$T_j$  = Junction Temperature

$\theta_{JA}$  = Junction-to-Ambient Thermal Resistance

$Pd\_total$  = Total Device Power Dissipation (example calculation is in section 1 above)

$T_A$  = Ambient Temperature

In order to calculate junction temperature, the appropriate junction-to-ambient thermal resistance  $\theta_{JA}$  must be used. Assuming no air flow and a multi-layer board, the appropriate value is  $39.5^\circ C/W$  per Table 7 below.

Therefore,  $T_j$  for an ambient temperature of  $70^\circ C$  with all outputs switching is:

$$70^\circ C + 0.793W * 39.5^\circ C/W = 101.3^\circ C. \text{ This is well below the limit of } 125^\circ C.$$

This calculation is only an example.  $T_j$  will obviously vary depending on the number of loaded outputs, supply voltage, air flow and the type of board (multi-layer).

**Table 7. Thermal Resistance  $\theta_{JA}$  for 32 Lead VFQFN, Forced Convection**

$\theta_{JA}$ Vs. Air Flow			
Meters per Second	0	1	2.5
Multi-Layer PCB, JEDEC Standard Test Boards	$39.5^\circ C/W$	$34.5^\circ C/W$	$31.0^\circ C/W$

## Reliability Information

**Table 8.  $\theta_{JA}$  vs. Air Flow Table for a 32 Lead VFQFN**

$\theta_{JA}$ vs. Air Flow			
Meters per Second	<b>0</b>	<b>1</b>	<b>2.5</b>
Multi-Layer PCB, JEDEC Standard Test Boards	39.5°C/W	34.5°C/W	31.0°C/W

## Transistor Count

The transistor count for ICS844S0258-07 is: 8989

# Package Outline and Package Dimensions

## Package Outline - K Suffix for 32 Lead VFQFN

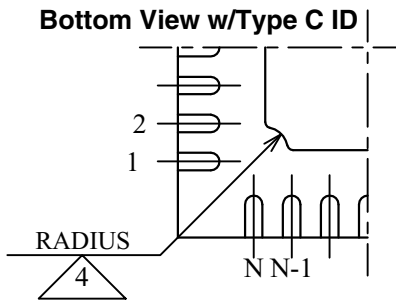
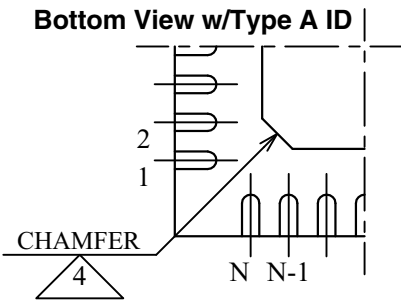
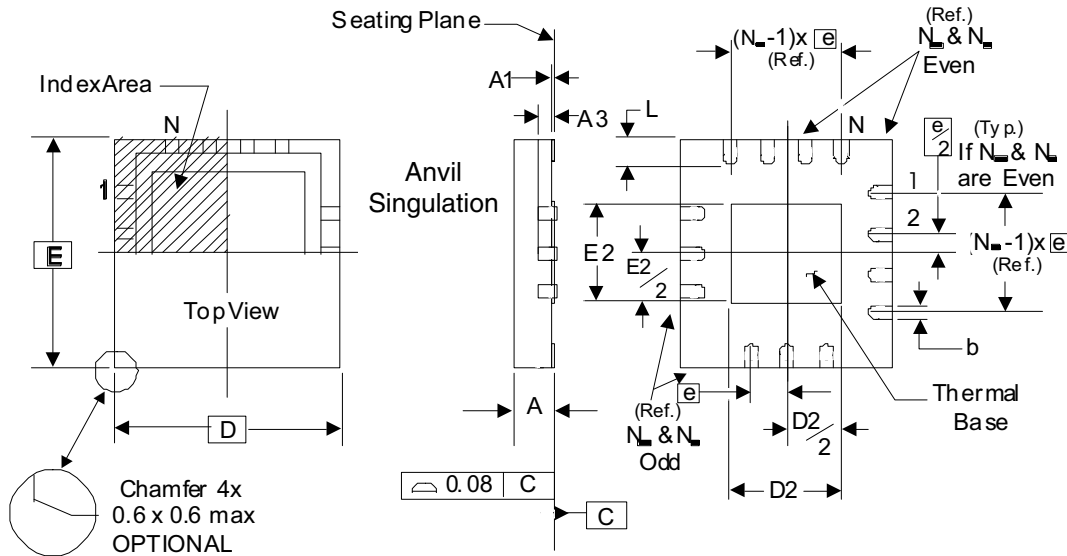

There are 2 methods of indicating pin 1 corner at the back of the VFQFN package:

1. Type A: Chamfer on the paddle (near pin 1)
2. Type C: Mouse bite on the paddle (near pin 1)

**Table 9. Package Dimensions**

JEDEC Variation: VHHD-2/-4 All Dimensions in Millimeters			
Symbol	Minimum	Nominal	Maximum
N		32	
A	0.80		1.00
A1	0		0.05
A3		0.25 Ref.	
b	0.18	0.25	0.30
N <sub>D</sub> & N <sub>E</sub>			8
D & E		5.00 Basic	
D2 & E2	3.0		3.3
e		0.50 Basic	
L	0.30	0.40	0.50

The following package mechanical drawing is a generic drawing that applies to any pin count VFQFN package. This drawing is not intended to convey the actual pin count or pin layout of this device. The pin count and pinout are shown on the front page. The package dimensions are in Table 9.

Reference Document: JEDEC Publication 95, MO-220

## Ordering Information

Table 10. Ordering Information

Part/Order Number	Marking	Package	Shipping Packaging	Temperature
844S0258CK-07LF	ICS0258C07L	"Lead-Free" 32 Lead VFQFN	Tray	0°C to 70°C
844S0258CK-07LFT	ICS0258C07L	"Lead-Free" 32 Lead VFQFN	Tape & Reel	0°C to 70°C

## Revision History Sheet

Rev	Table	Page	Description of Change	Date
A	T10 T10	1 19 19	Deleted HyperClock logo. Deleted quantity from ordering information. Deleted leaded parts note.	12/2/2013



## IMPORTANT NOTICE AND DISCLAIMER

RENESAS ELECTRONICS CORPORATION AND ITS SUBSIDIARIES (“RENESAS”) PROVIDES TECHNICAL SPECIFICATIONS AND RELIABILITY DATA (INCLUDING DATASHEETS), DESIGN RESOURCES (INCLUDING REFERENCE DESIGNS), APPLICATION OR OTHER DESIGN ADVICE, WEB TOOLS, SAFETY INFORMATION, AND OTHER RESOURCES “AS IS” AND WITH ALL FAULTS, AND DISCLAIMS ALL WARRANTIES, EXPRESS OR IMPLIED, INCLUDING, WITHOUT LIMITATION, ANY IMPLIED WARRANTIES OF MERCHANTABILITY, FITNESS FOR A PARTICULAR PURPOSE, OR NON-INFRINGEMENT OF THIRD-PARTY INTELLECTUAL PROPERTY RIGHTS.

These resources are intended for developers who are designing with Renesas products. You are solely responsible for (1) selecting the appropriate products for your application, (2) designing, validating, and testing your application, and (3) ensuring your application meets applicable standards, and any other safety, security, or other requirements. These resources are subject to change without notice. Renesas grants you permission to use these resources only to develop an application that uses Renesas products. Other reproduction or use of these resources is strictly prohibited. No license is granted to any other Renesas intellectual property or to any third-party intellectual property. Renesas disclaims responsibility for, and you will fully indemnify Renesas and its representatives against, any claims, damages, costs, losses, or liabilities arising from your use of these resources. Renesas' products are provided only subject to Renesas' Terms and Conditions of Sale or other applicable terms agreed to in writing. No use of any Renesas resources expands or otherwise alters any applicable warranties or warranty disclaimers for these products.

(Disclaimer Rev.1.01)

### Corporate Headquarters

TOYOSU FORESIA, 3-2-24 Toyosu,  
Koto-ku, Tokyo 135-0061, Japan  
[www.renesas.com](http://www.renesas.com)

### Trademarks

Renesas and the Renesas logo are trademarks of Renesas Electronics Corporation. All trademarks and registered trademarks are the property of their respective owners.

### Contact Information

For further information on a product, technology, the most up-to-date version of a document, or your nearest sales office, please visit [www.renesas.com/contact-us/](http://www.renesas.com/contact-us/).