

### General Description

The 851021 is a 1-to-21 Differential HCSL Fanout Buffer. The 851021 is designed to translate any differential signal levels to differential HCSL output levels. An external reference resistor is used to set the value of the current supplied to an external load/termination resistor. The load resistor value is chosen to equal the value of the characteristic line impedance of 50Ω. The 851021 is characterized at an operating supply voltage of 3.3V.

The differential HCSL outputs, accurate crossover voltage and duty cycle make the 851021 ideal for interfacing to PCI Express and FBDIMM applications.

### Features

- Twenty-one differential HCSL outputs
- Translates any differential input signal (LVPECL, LVHSTL, LVDS, HCSL) to HCSL levels without external bias networks
- Maximum output frequency: 250MHz
- Output skew: 395ps (maximum)
- Part-to-part skew: 335ps (maximum)
- Output drift: 140ps (maximum)
- V<sub>OH</sub>: 850mV (maximum)
- Full 3.3V supply voltage
- Available in lead-free (RoHS 6) package
- 0°C to 70°C ambient operating temperature

### Block Diagram

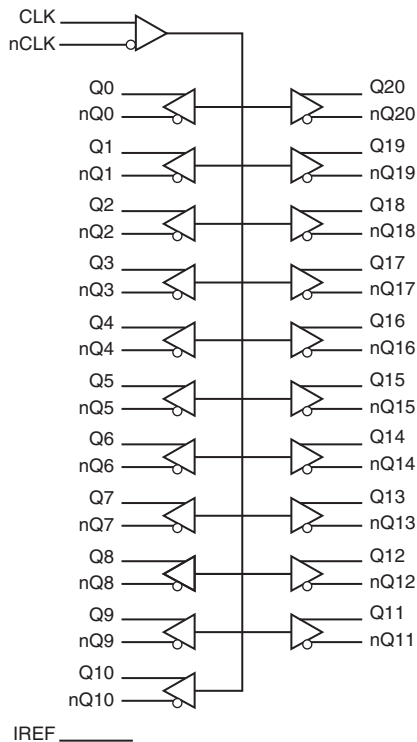

### Pin Assignment

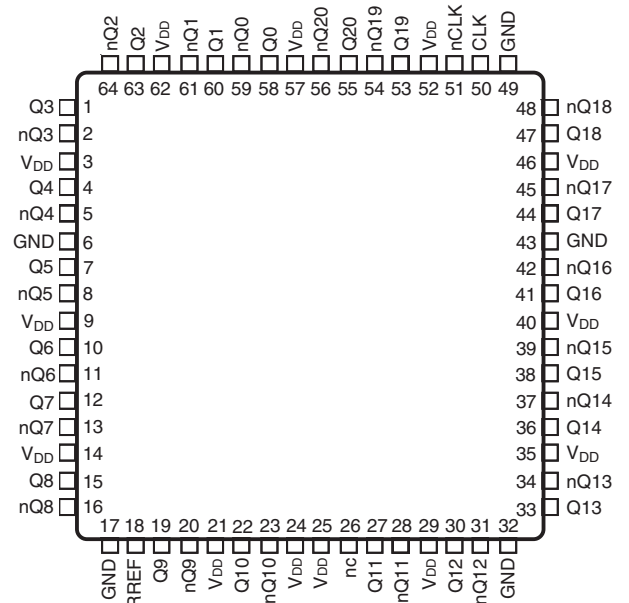

**ICS851021**  
**64-Lead TQFP, E-Pad**  
**10mm x 10mm x 1.0mm package body**  
**Y Package**  
**Top View**

## Pin Description Table

Table 1. Pin Descriptions

Number	Name	Type	Description
1, 2	Q3, nQ3	Output	Differential output pair. Differential HCSL interface levels.
3, 9, 14, 21, 24, 25, 29, 35, 40, 46, 52, 57, 62	V <sub>DD</sub>	Power	Positive supply pins.
4, 5	Q4, nQ4	Output	Differential output pair. Differential HCSL interface levels.
6, 17, 32, 43, 49	GND	Power	Power supply ground.
7, 8	Q5, nQ5	Output	Differential output pair. Differential HCSL interface levels.
10, 11	Q6, nQ6	Output	Differential output pair. Differential HCSL interface levels.
12, 13	Q7, nQ7	Output	Differential output pair. Differential HCSL interface levels.
15, 16	Q8, nQ8	Output	Differential output pair. Differential HCSL interface levels.
18	RREF	Input	External fixed precision resistor (950Ω) from this pin to ground provides a reference current used for differential current-mode Qx, nQx clock outputs.
19, 20	Q9, nQ9	Output	Differential output pair. Differential HCSL interface levels.
22, 23	Q10, nQ10	Output	Differential output pair. Differential HCSL interface levels.
26	nc	unused	No connect.
27, 28	Q11, nQ11	Output	Differential output pair. Differential HCSL interface levels.
30, 31	Q12, nQ12	Output	Differential output pair. Differential HCSL interface levels.
33, 34	Q13, nQ13	Output	Differential output pair. Differential HCSL interface levels.
36, 37	Q14, nQ14	Output	Differential output pair. Differential HCSL interface levels.
38, 39	Q15, nQ15	Output	Differential output pair. Differential HCSL interface levels.
41, 42	Q16, nQ16	Output	Differential output pair. Differential HCSL interface levels.
44, 45	Q17, nQ17	Output	Differential output pair. Differential HCSL interface levels.
47, 48	Q18, nQ18	Output	Differential output pair. Differential HCSL interface levels.
50	CLK	Input	Non-inverting differential input.
51	nCLK	Input	Inverting differential clock input.
53, 54	Q19, nQ19	Output	Differential output pair. Differential HCSL interface levels.
55, 56	Q20, nQ20	Output	Differential output pair. Differential HCSL interface levels.
58, 59	Q0, nQ0	Output	Differential output pair. Differential HCSL interface levels.
60, 61	Q1, nQ1	Output	Differential output pair. Differential HCSL interface levels.
63, 64	Q2, nQ2	Output	Differential output pair. Differential HCSL interface levels.

## Output Driver Current

The 851021 outputs are HCSL differential current drive with the current being set with a resistor from I<sub>REF</sub> to ground. For a *single load* and a 50Ω P.C. board trace, the drive current would typically be set with a R<sub>REF</sub> of 950Ω which produces an I<sub>REF</sub> of 1.16mA. The I<sub>REF</sub> is multiplied by a current mirror to an output drive of 12\*1.16mA or 13.90mA. See *Figure 1* for current mirror and output drive details.

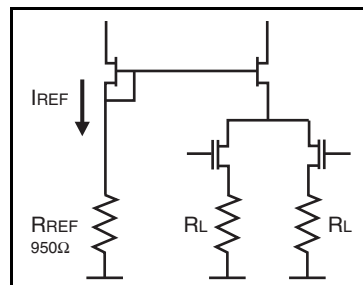

Figure 1. HCSL Current Mirror and Output Drive

## Absolute Maximum Ratings

NOTE: Stresses beyond those listed under *Absolute Maximum Ratings* may cause permanent damage to the device. These ratings are stress specifications only. Functional operation of product at these conditions or any conditions beyond those listed in the *DC Characteristics* or *AC Characteristics* is not implied. Exposure to absolute maximum rating conditions for extended periods may affect product reliability.

Item	Rating
Supply Voltage, $V_{DD}$	4.6V
Inputs, $V_I$	-0.5V to $V_{DD} + 0.5V$
Outputs, $I_O$	-0.5V to $V_{DD} + 0.5V$
Package Thermal Impedance, $\theta_{JA}$	31.8°C/W (0 mps)
Storage Temperature, $T_{STG}$	-65°C to 150°C

## DC Electrical Characteristics

**Table 2A. Power Supply DC Characteristics,  $V_{DD} = 3.3V \pm 5\%$ ,  $T_A = 0^\circ C$  to  $70^\circ C$**

Symbol	Parameter	Test Conditions	Minimum	Typical	Maximum	Units
$V_{DD}$	Core Supply Voltage		3.135	3.3	3.465	V
$I_{DD}$	Power Supply Current; NOTE 1				105	mA

**Table 2B. Differential DC Characteristics,  $V_{DD} = 3.3V \pm 5\%$ ,  $T_A = 0^\circ C$  to  $70^\circ C$**

Symbol	Parameter		Test Conditions	Minimum	Typical	Maximum	Units
$I_{IH}$	Input High Current	CLK, nCLK	$V_{DD} = V_{IN} = 3.465V$			5	$\mu A$
$I_{IL}$	Input Low Current	CLK, nCLK	$V_{DD} = 3.465V, V_{IN} = 0V$			5	$\mu A$
$V_{PP}$	Peak-to-Peak Voltage; NOTE 1			0.15		1.3	V
$V_{CMR}$	Common Mode Input Voltage; NOTE 1, 2			GND + 0.5		$V_{DD} - 0.85$	V

NOTE 1:  $V_{IL}$  should not be less than -0.3V.

NOTE 2: Common mode input voltage is defined as  $V_{IH}$ .

## AC Electrical Characteristics

**Table 3. HCSL AC Characteristics,  $V_{DD} = 3.3V \pm 5\%$ ,  $T_A = 0^\circ C$  to  $70^\circ C$**

Symbol	Parameter	Test Conditions	Minimum	Typical	Maximum	Units
$f_{MAX}$	Output Frequency				250	MHz
$t_{PD}$	Propagation Delay; NOTE 1	Measured on at $V_{OX}$	1.5		2.75	ns
$t_{sk(o)}$	Output Skew; NOTE 2, 3	Measured on at $V_{OX}$			395	ps
$t_{sk(pp)}$	Part-to-Part Skew; NOTE 3, 4				335	ps
$f_{jit}$	Buffer Additive Phase Jitter, RMS; refer to Additive Phase Jitter Section	CLK = 200MHz, Integration Range: 12kHz – 30MHz		0.20		ps
$t_{sk(drift)}$	Output Drift; NOTE 5				140	ps
$V_{MAX}$	Absolute Max Output Voltage; NOTE 6	$f \leq 150MHz$	500		850	mV
$V_{MIN}$	Absolute Min Output Voltage; NOTE 6	$f \leq 150MHz$	-150		150	mV
$V_{CROSS}$	Absolute Crossing Voltage; NOTE 7, 8, 9		250		550	mV
$\Delta V_{CROSS}$	Total Variation of $V_{CROSS}$ over all edges; NOTE 7, 8, 10				140	mV
	Rise/Fall Edge Rate; NOTE 11, 12		0.6		4.0	V/ns
	Rise/Fall Time Matching; NOTE 13				20	%
odc	Output Duty Cycle; NOTE 14		47		53	%

**NOTE:** Electrical parameters are guaranteed over the specified ambient operating temperature range, which is established when the device is mounted in a test socket with maintained transverse airflow greater than 500 lpm. The device will meet specifications after thermal equilibrium has been reached under these conditions.

**NOTE:** Current adjust set for  $V_{OH} = 0.7V$ . Measurements refer to PCIEX outputs only.

**NOTE:** Characterized using an  $R_{REF}$  value of  $950\Omega$  resistor.

**NOTE 1:** Measured from the differential input cross point to the differential output crossing point.

**NOTE 2:** Defined as skew between outputs at the same supply voltage and with equal load conditions. Measured at the differential output cross point.

**NOTE 3:** This parameter is defined in accordance with JEDEC Standard 65.

**NOTE 4:** Defined as skew between outputs on different devices operating at the same supply voltage, same frequency, same temperature and with equal load conditions. Using the same type of inputs on each device, the outputs are measured at the differential cross point.

**NOTE 5:** Output Drift is measured as the change in the time placement of the differential cross point for each output on a given device due to a change in temperature and supply voltage. Measured at the differential cross point.

**NOTE 6:** Measurement using  $R_{REF} = 950\Omega$ ,  $R_{LOAD} = 50\Omega$ .

**NOTE 7:** Measurement taken from single-ended waveform.

**NOTE 8:** Measured at crossing point where the instantaneous voltage value of the rising edge of Qx equals the falling edge of nQx. See Parameter Measurement Information Section.

**NOTE 9:** Refers to the total variation from the lowest crossing point to the highest, regardless of which edge is crossing. Refers to all crossing points for this measurement. See Parameter Measurement Information Section.

**NOTE 10:** Defined as the total variation of all crossing voltage of rising Qx and falling nQx. This is the maximum allowed variance in the  $V_{CROSS}$  for any particular system. See Parameter Measurement Information Section.

**NOTE 11:** Measurement taken from differential waveform.

**NOTE 12:** Measurement from -150mV to +150mV on the differential waveform (derived from Qx minus nQx). The signal must be monotonic through the measurement region for rise and fall time. The 300mV measurement window is centered on the differential zero crossing.

**NOTE 13:** Matching applies to rising edge rate for Qx and falling edge rate for nQx. It is measured using a  $\pm 75mV$  window centered on the median cross point where Qx rising meets nQx falling.

**NOTE 14:** Assuming 50% input duty cycle. Data taken at  $f \leq 200MHz$ , unless otherwise specified.

## Additive Phase Jitter

The spectral purity in a band at a specific offset from the fundamental compared to the power of the fundamental is called the ***dBc Phase Noise***. This value is normally expressed using a Phase noise plot and is most often the specified plot in many applications. Phase noise is defined as the ratio of the noise power present in a 1Hz band at a specified offset from the fundamental frequency to the power value of the fundamental. This ratio is expressed in decibels (dBm) or a ratio

of the power in the 1Hz band to the power in the fundamental. When the required offset is specified, the phase noise is called a ***dBc*** value, which simply means dBm at a specified offset from the fundamental. By investigating jitter in the frequency domain, we get a better understanding of its effects on the desired application over the entire time record of the signal. It is mathematically possible to calculate an expected bit error rate given a phase noise plot.

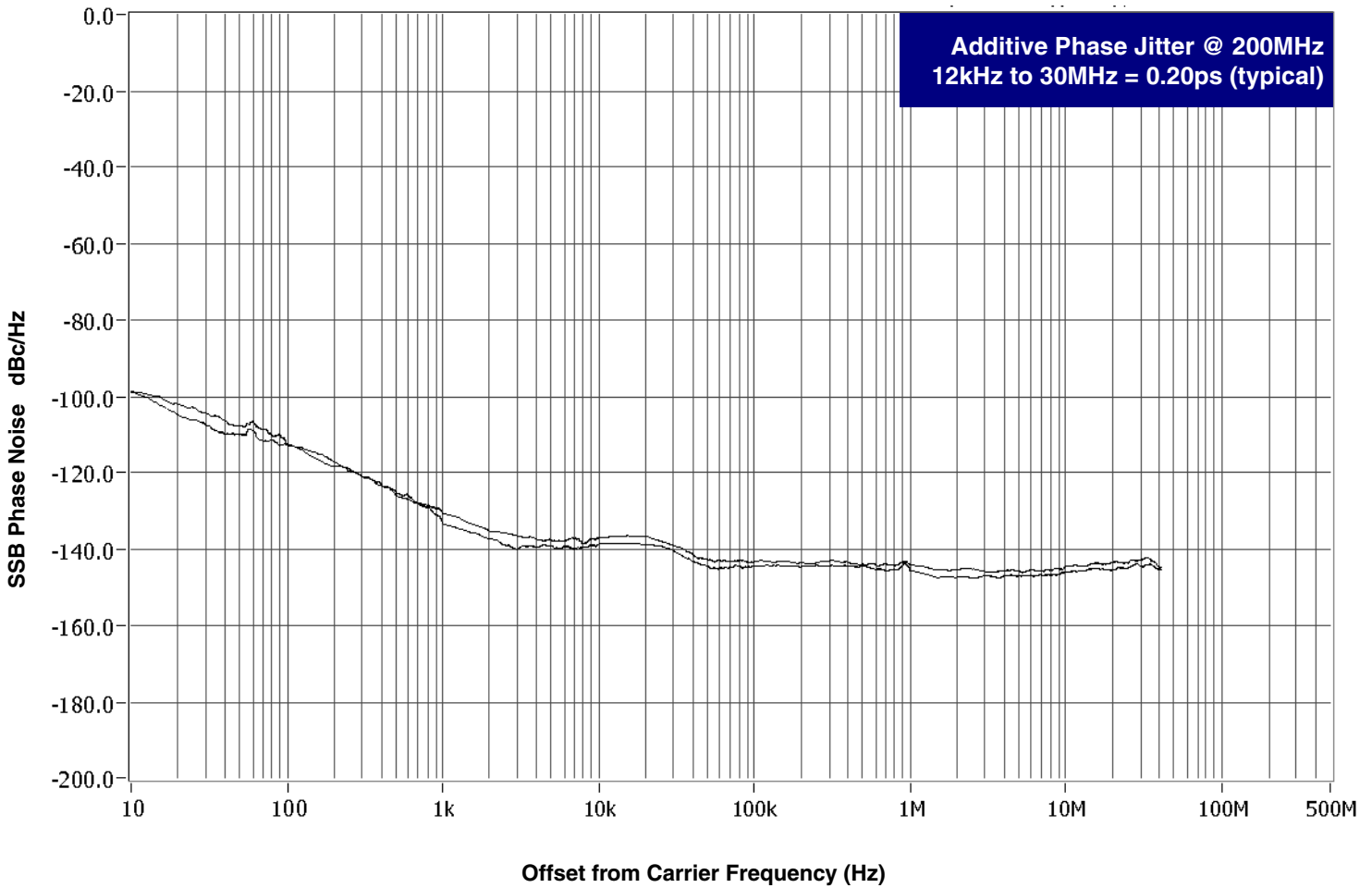

As with most timing specifications, phase noise measurements has issues relating to the limitations of the equipment. Often the noise floor of the equipment is higher than the noise floor of the device. This

is illustrated above. The device meets the noise floor of what is shown, but can actually be lower. The phase noise is dependent on the input source and measurement equipment.

## Parameter Measurement Information

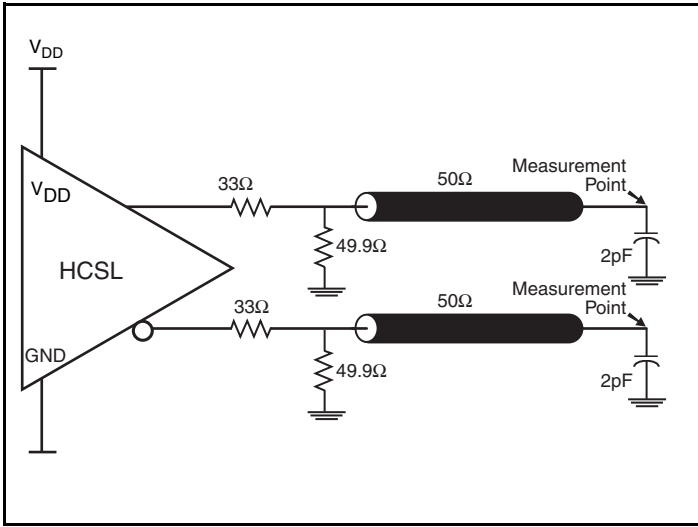

HCSL Output Load AC Test Circuit

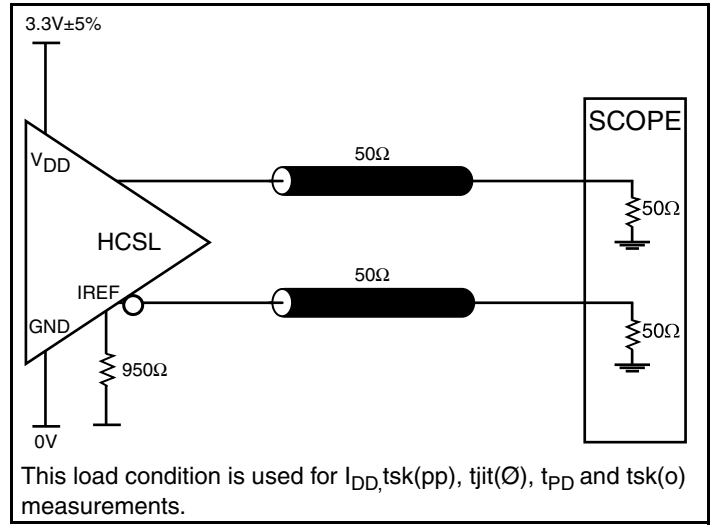

HCSL Output Load AC Test Circuit

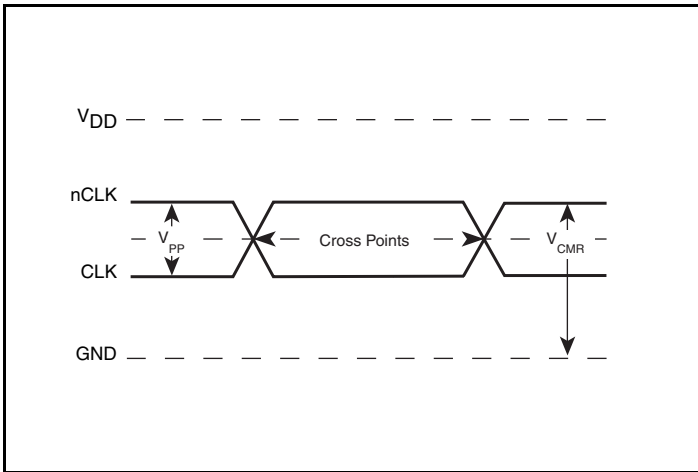

Differential Input Levels

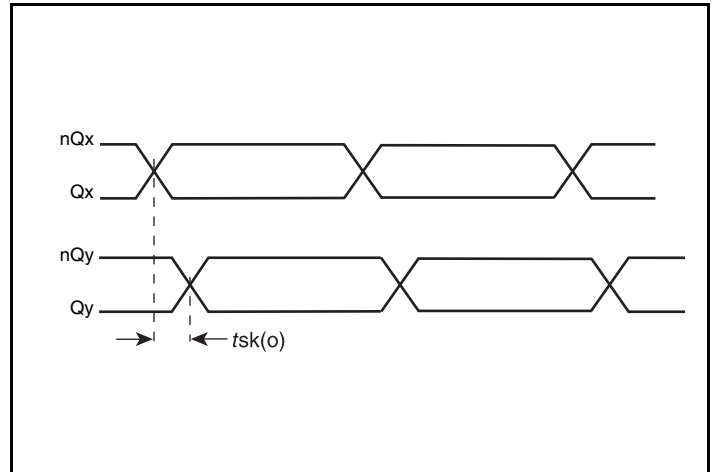

Output Skew

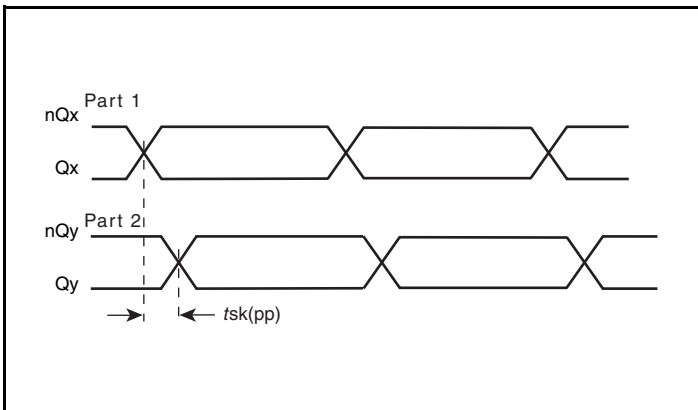

Part-to-Part Skew

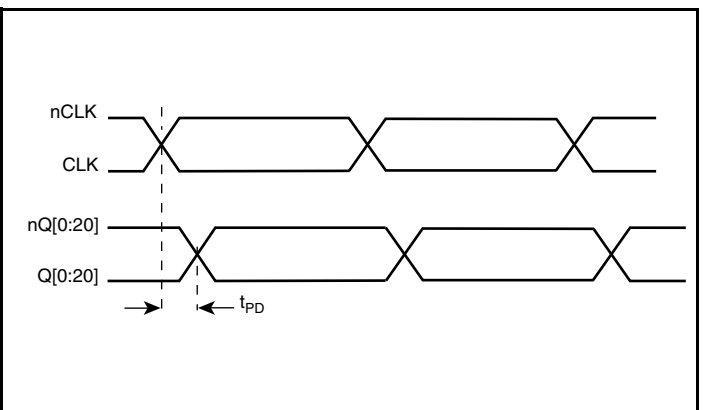

Propagation Delay

## Parameter Measurement Information, continued

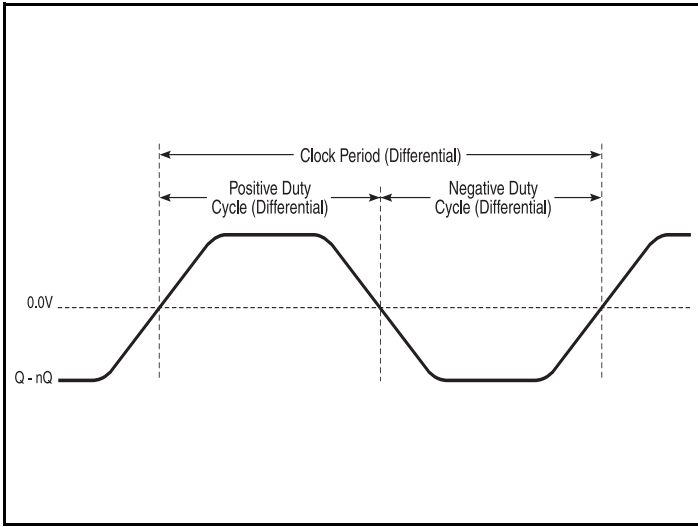

Differential Measurement Points for Duty Cycle/Period

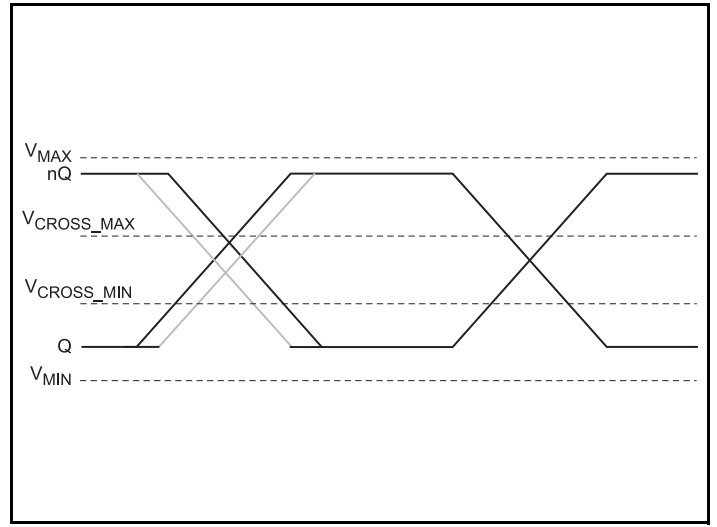

Single-ended Measurement Points for Absolute Cross Point and Swing

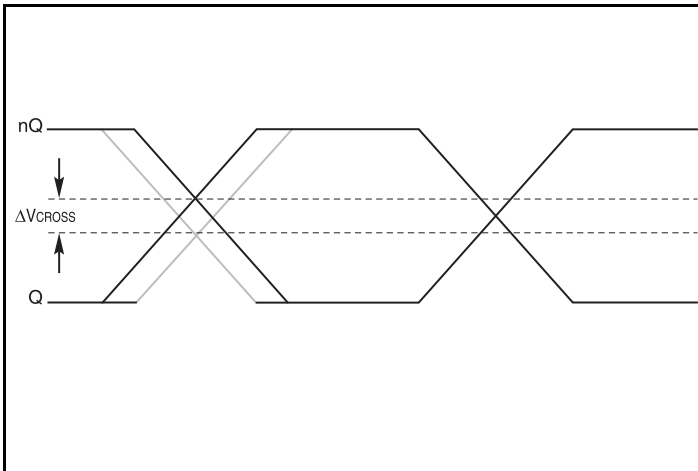

Single-ended Measurement Points for Delta Cross Point

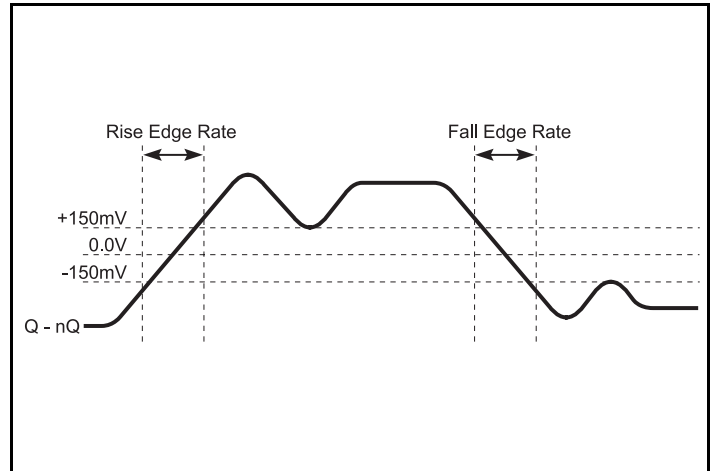

Differential Measurement Points for Rise/Fall Edge Rate

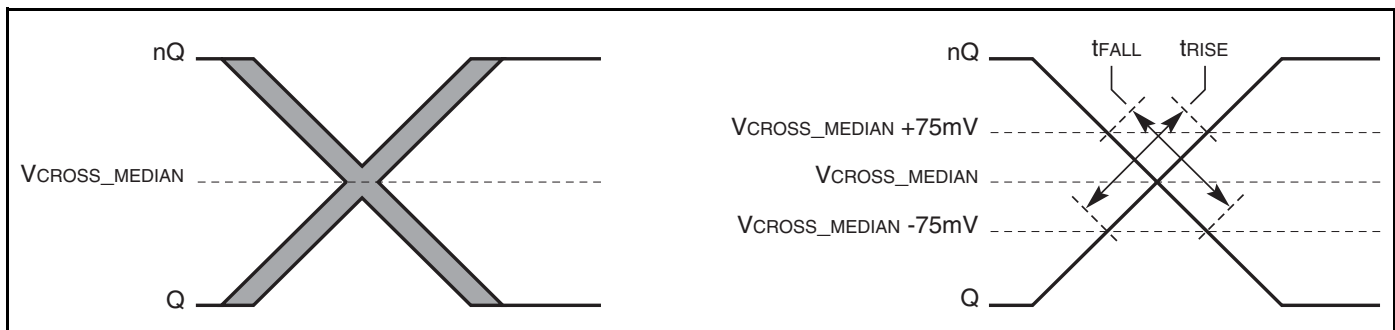

Single-ended Measurement Points for Rise/Fall Matching

## Applications Information

### Recommendations for Unused Output Pins

#### Outputs:

##### Differential Outputs

All unused differential outputs can be left floating. We recommend that there is no trace attached. Both sides of the differential output pair should either be left floating or terminated.

### Wiring the Differential Input to Accept Single-Ended Levels

Figure 2 shows how a differential input can be wired to accept single ended levels. The reference voltage  $V_1 = V_{DD}/2$  is generated by the bias resistors R1 and R2. The bypass capacitor (C1) is used to help filter noise on the DC bias. This bias circuit should be located as close to the input pin as possible. The ratio of R1 and R2 might need to be adjusted to position the  $V_1$  in the center of the input voltage swing. For example, if the input clock is driven from a single-ended 2.5V LVCMOS driver and the DC offset (or swing center) of this signal is 1.25V, the R1 and R2 values should be adjusted to set the  $V_1$  at 1.25V. The values below are for when both the single ended swing and  $V_{DD}$  are at the same voltage. This configuration requires that the sum of the output impedance of the driver ( $R_o$ ) and the series resistance ( $R_s$ ) equals the transmission line impedance. In addition, matched termination at the input will attenuate the signal in half. This can be done in one of two ways. First, R3 and R4 in parallel should

equal the transmission line impedance. For most 50Ω applications, R3 and R4 can be 100Ω. The values of the resistors can be increased to reduce the loading for slower and weaker LVCMOS driver. When using single-ended signaling, the noise rejection benefits of differential signaling are reduced. Even though the differential input can handle full rail LVCMOS signaling, it is recommended that the amplitude be reduced while maintaining an edge rate faster than 1V/ns. The datasheet specifies a lower differential amplitude, however this only applies to differential signals. For single-ended applications, the swing can be larger, however  $V_{IL}$  cannot be less than -0.3V and  $V_{IH}$  cannot be more than  $V_{DD} + 0.3V$ . Though some of the recommended components might not be used, the pads should be placed in the layout. They can be utilized for debugging purposes. The datasheet specifications are characterized and guaranteed by using a differential signal.

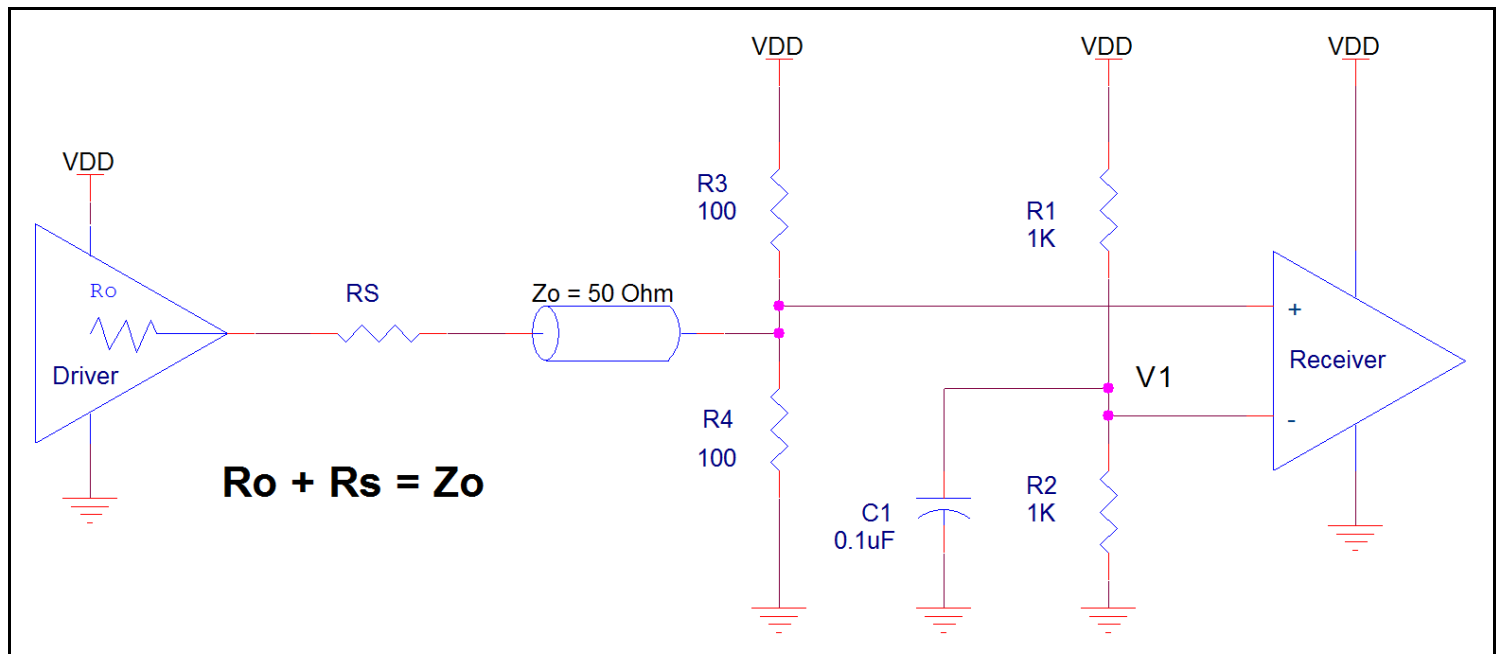

Figure 2. Recommended Schematic for Wiring a Differential Input to Accept Single-ended Levels



## Differential Clock Input Interface

The CLK/nCLK accepts HCSL, LVDS, LVPECL and LVHSTL and other differential signals. Both differential signals must meet the  $V_{PP}$  and  $V_{CMR}$  input requirements. *Figures 3A to 3E* show interface examples for the CLK/nCLK input driven by the most common driver types. The input interfaces suggested here are examples only.

Please consult with the vendor of the driver component to confirm the driver termination requirements. For example in Figure 3A, the input termination applies for IDT open emitter LVHSTL drivers. If you are using an LVHSTL driver from another vendor, use their termination recommendation.

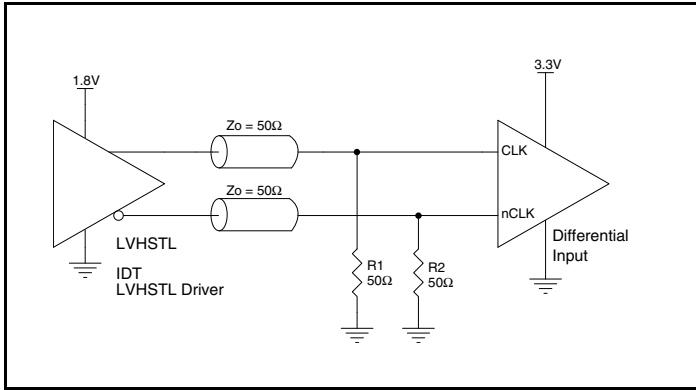

**Figure 3A. CLK/nCLK Input Driven by an IDT Open Emitter LVHSTL Driver**

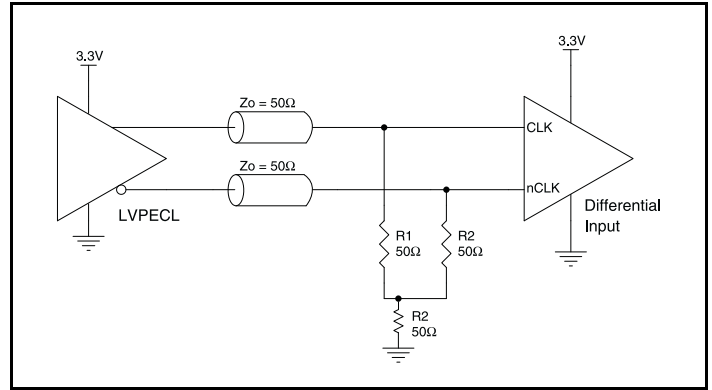

**Figure 3B. CLK/nCLK Input Driven by a 3.3V LVPECL Driver**

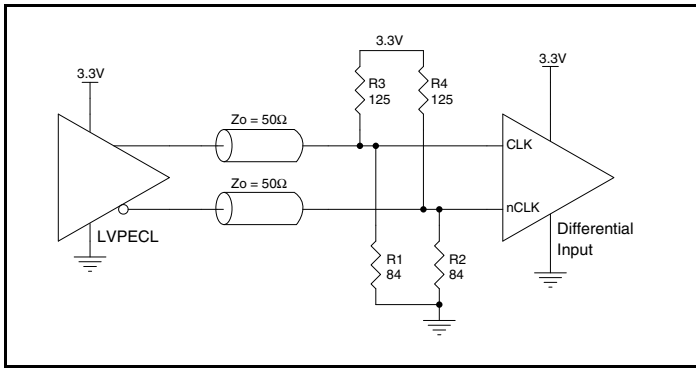

**Figure 3C. CLK/nCLK Input Driven by a 3.3V LVPECL Driver**

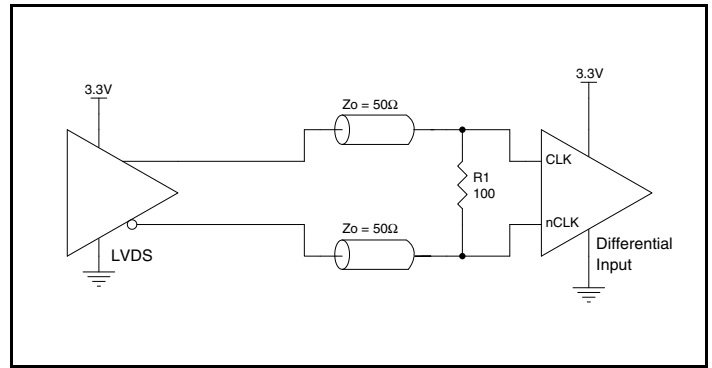

**Figure 3D. CLK/nCLK Input Driven by a 3.3V LVDS Driver**

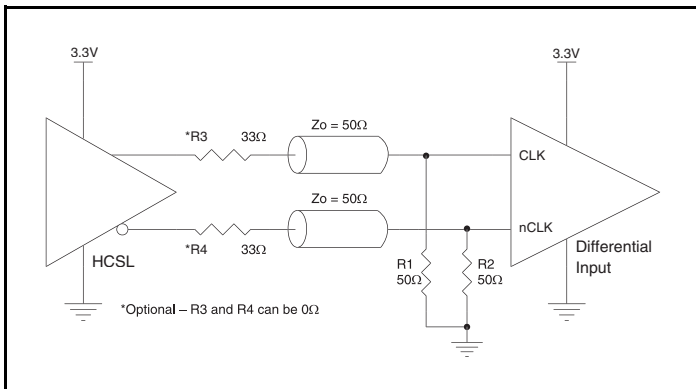
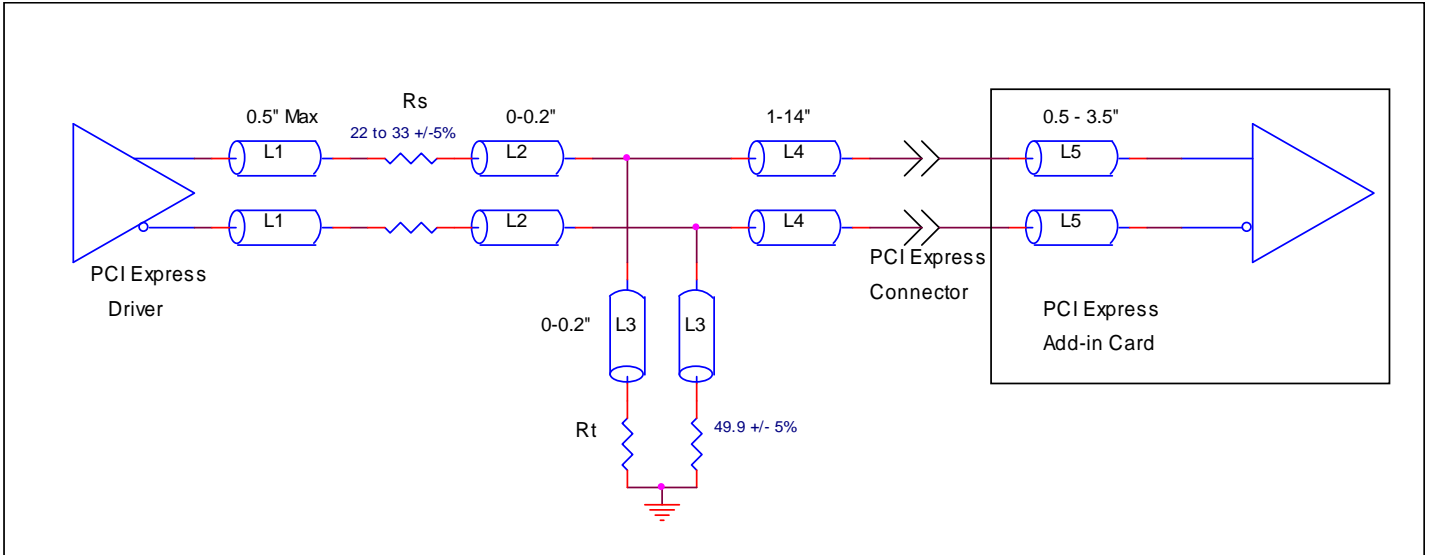

**Figure 3E. CLK/nCLK Input Driven by a 3.3V HCSL Driver**

## Recommended Termination

Figure 4A is the recommended source termination for applications where the driver and receiver will be on a separate PCBs. This termination is the standard for PCI Express™ and HCSL output types.

All traces should be 50Ω impedance single-ended or 100Ω differential.



**Figure 4A. Recommended Source Termination (where the driver and receiver will be on separate PCBs)**

Figure 4B is the recommended termination for applications where a point-to-point connection can be used. A point-to-point connection contains both the driver and the receiver on the same PCB. With a matched termination at the receiver, transmission-line reflections will

be minimized. In addition, a series resistor ( $R_s$ ) at the driver offers flexibility and can help dampen unwanted reflections. The optional resistor can range from 0Ω to 33Ω. All traces should be 50Ω impedance single-ended or 100Ω differential.

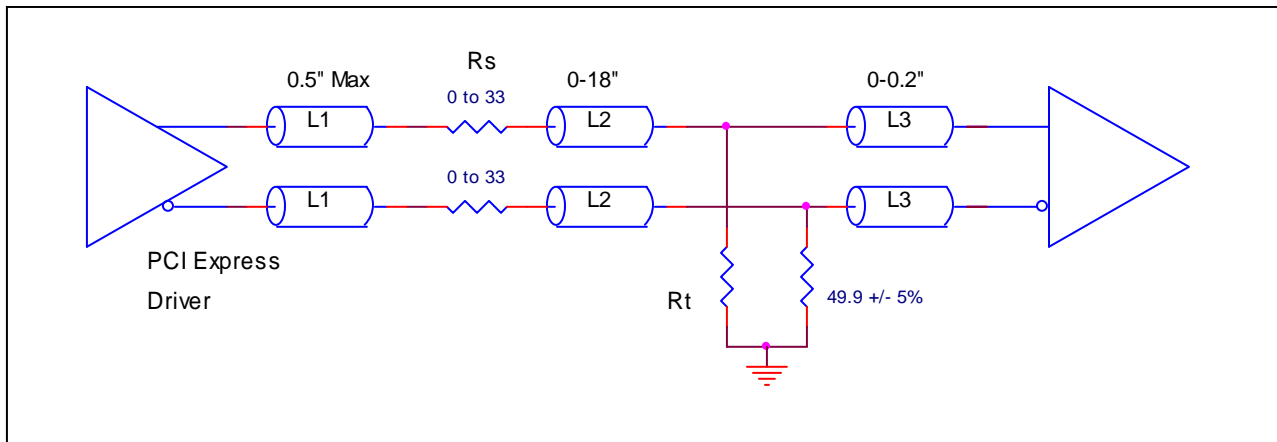

**Figure 4B. Recommended Termination (where a point-to-point connection can be used)**

## EPAD Thermal Release Path

In order to maximize both the removal of heat from the package and the electrical performance, a land pattern must be incorporated on the Printed Circuit Board (PCB) within the footprint of the package corresponding to the exposed metal pad or exposed heat slug on the package, as shown in *Figure 5*. The solderable area on the PCB, as defined by the solder mask, should be at least the same size/shape as the exposed pad/slug area on the package to maximize the thermal/electrical performance. Sufficient clearance should be designed on the PCB between the outer edges of the land pattern and the inner edges of pad pattern for the leads to avoid any shorts.

While the land pattern on the PCB provides a means of heat transfer and electrical grounding from the package to the board through a solder joint, thermal vias are necessary to effectively conduct from the surface of the PCB to the ground plane(s). The land pattern must be connected to ground through these vias. The vias act as “heat pipes”. The number of vias (i.e. “heat pipes”) are application specific

and dependent upon the package power dissipation as well as electrical conductivity requirements. Thus, thermal and electrical analysis and/or testing are recommended to determine the minimum number needed. Maximum thermal and electrical performance is achieved when an array of vias is incorporated in the land pattern. It is recommended to use as many vias connected to ground as possible. It is also recommended that the via diameter should be 12 to 13mils (0.30 to 0.33mm) with 1oz copper via barrel plating. This is desirable to avoid any solder wicking inside the via during the soldering process which may result in voids in solder between the exposed pad/slug and the thermal land. Precautions should be taken to eliminate any solder voids between the exposed heat slug and the land pattern. Note: These recommendations are to be used as a guideline only. For further information, refer to the Application Note on the *Surface Mount Assembly* of Amkor’s Thermally/Electrically Enhance Leadframe Base Package, Amkor Technology.

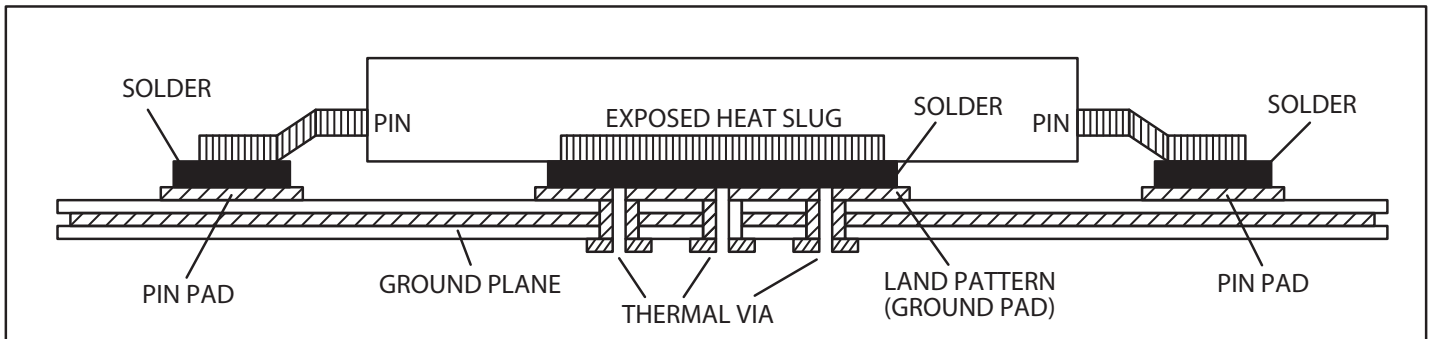

**Figure 5. Assembly for Exposed Pad Thermal Release Path - Side View (drawing not to scale)**

## Power Considerations

This section provides information on power dissipation and junction temperature for the 851021. Equations and example calculations are also provided.

### 1. Power Dissipation.

The total power dissipation for the 851021 is the sum of the core power plus the power dissipated in the load(s). The following is the power dissipation for  $V_{DD} = 3.3V + 5\% = 3.465V$ , which gives worst case results.

- Power (core)<sub>MAX</sub> =  $V_{DD\_MAX} * I_{DD\_MAX} = 3.465V * 105mA = \mathbf{363.825mW}$
- Power (outputs)<sub>MAX</sub> = **44.5mW/Loaded Output Pair**  
If all outputs are loaded, the total power is  $21 * 44.5mW = \mathbf{934.5mW}$

**Total Power<sub>MAX</sub>** (3.465V, with all outputs switching) =  $363.825mW + 934.5mW = \mathbf{1298.325mW}$

### 2. Junction Temperature.

Junction temperature,  $T_j$ , is the temperature at the junction of the bond wire and bond pad directly affects the reliability of the device. The maximum recommended junction temperature is 125°C. Limiting the internal transistor junction temperature,  $T_j$ , to 125°C ensures that the bond wire and bond pad temperature remains below 125°C.

The equation for  $T_j$  is as follows:  $T_j = \theta_{JA} * Pd_{total} + T_A$

$T_j$  = Junction Temperature

$\theta_{JA}$  = Junction-to-Ambient Thermal Resistance

$Pd_{total}$  = Total Device Power Dissipation (example calculation is in section 1 above)

$T_A$  = Ambient Temperature

In order to calculate junction temperature, the appropriate junction-to-ambient thermal resistance  $\theta_{JA}$  must be used. Assuming no air flow and a multi-layer board, the appropriate value is 31.8°C/W per Table 4 below.

Therefore,  $T_j$  for an ambient temperature of 70°C with all outputs switching is:

$$70^\circ\text{C} + 1.298\text{W} * 31.8^\circ\text{C/W} = 111.3^\circ\text{C}. \text{ This is below the limit of } 125^\circ\text{C}.$$

This calculation is only an example.  $T_j$  will obviously vary depending on the number of loaded outputs, supply voltage, air flow and the type of board (multi-layer).

**Table 4. Thermal Resistance  $\theta_{JA}$  for 64 Lead TQFP, E-Pad Forced Convection**

$\theta_{JA}$ by Velocity			
Meters per Second	0	1	2.5
Multi-Layer PCB, JEDEC Standard Test Boards	31.8°C/W	25.8°C/W	24.2°C/W

The purpose of this section is to calculate power dissipation on the IC per HCSL output pair.

HCSL output driver circuit and termination are shown in *Figure 6*.

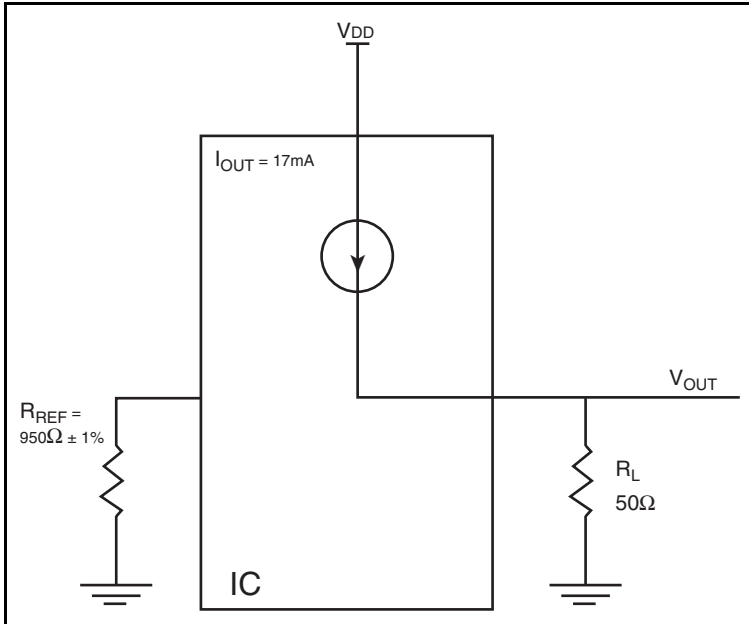

**Figure 6. HCSL Driver Circuit and Termination**

HCSL is a current steering output which sources a maximum of 17mA of current per output. To calculate worst case on-chip power dissipation, use the following equations which assume a 50Ω load to ground.

The highest power dissipation occurs when  $V_{DD\_MAX}$ .

$$\text{Power} = (V_{DD\_MAX} - V_{OUT}) * I_{OUT}$$

$$\text{since } V_{OUT} = I_{OUT} * R_L$$

$$= (V_{DD\_MAX} - I_{OUT} * R_L) * I_{OUT}$$

$$= (3.465V - 17mA * 50\Omega) * 17mA$$

Total Power Dissipation per output pair = **44.5mW**

## Reliability Information

**Table 5.  $\theta_{JA}$  vs. Air Flow Table for a 64 Lead TQFP, E-Pad**

$\theta_{JA}$ vs. Air Flow			
Meters per Second	0	1	2.5
Multi-Layer PCB, JEDEC Standard Test Boards	31.8°C/W	25.8°C/W	24.2°C/W

## Transistor Count

The transistor count for 851021 is: 843

# Package Outline and Package Dimensions

## Package Outline - Y Suffix for 64 Lead TQFP, E-Pad

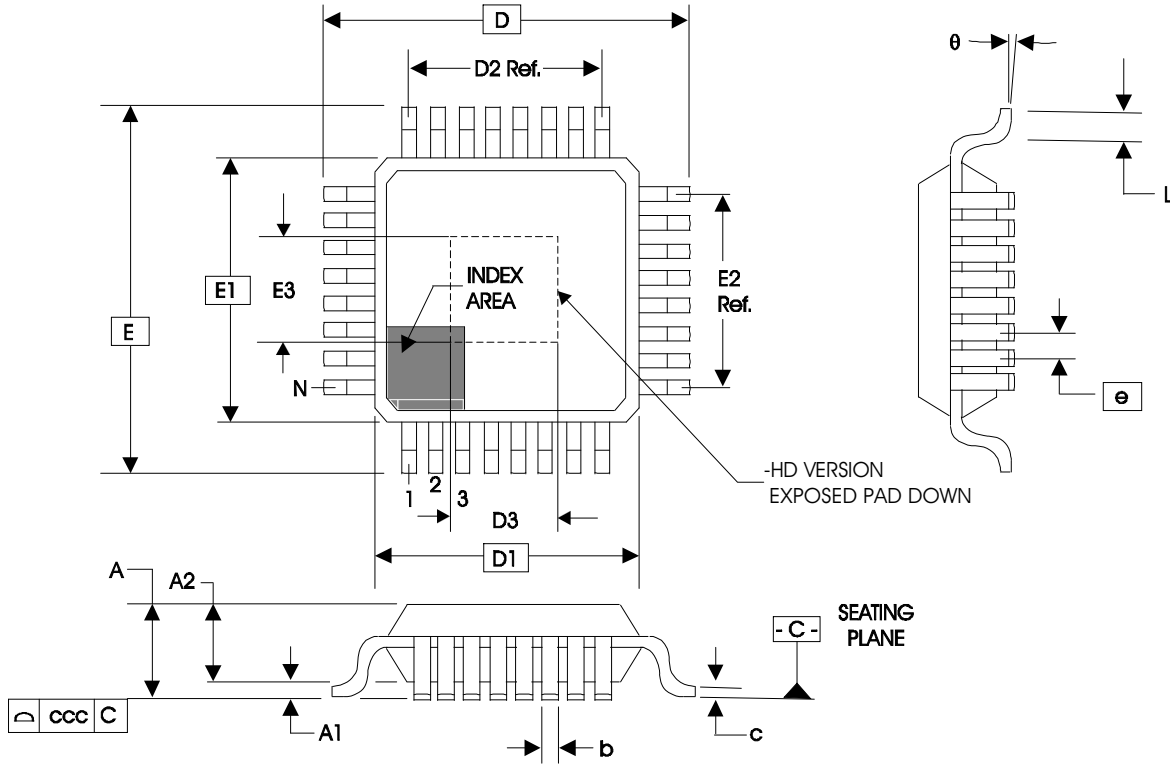

Table 6. Package Dimensions for 64 Lead TQFP, E-Pad

JEDEC Variation: ACD			
All Dimensions in Millimeters			
Symbol	Minimum	Nominal	Maximum
N	64		
A			1.20
A1	0.05	0.10	0.15
A2	0.95	1.00	1.05
b	0.17	0.22	0.27
c	0.09		0.20
D & E	12.00 Basic		
D1 & E1	10.00 Basic		
D2 & E2	7.50 Ref.		
D3 & E3	4.5		5.5
e	0.50 Basic		
L	0.45	0.60	0.75
theta	0°		7°
ccc			0.08

Reference Document: JEDEC Publication 95, MS-026

## Ordering Information

Table 7. Ordering Information

Part/Order Number	Marking	Package	Shipping Packaging	Temperature
851021AYLF	ICS851021AYL	64 Lead TQFP, E-Pad, Lead-Free	Tray	0°C to 70°C
851021AYLFT	ICS851021AYL	64 Lead TQFP, E-Pad, Lead-Free	Tape & Reel	0°C to 70°C



## Revision History Sheet

Rev	Table	Page	Description of Change	Date
B	T1	1 2 12	Pin Assignment, corrected pin 25 from $V_{DDA}$ to $V_{DD}$ . Pin Description Table - deleted $V_{DDA}$ (pin #25) row, and added pin #25 to $V_{DD}$ row. Power Considerations - corrected total power calculation and $T_j$ calculation.	5/25/08
B	T3  T6	4 8 9 15	AC Characteristics Table - added Thermal note. Updated Wiring the Differential Input to Accept Single Ended Levels. Updated Differential Clock Input Interface. Package Dimensions - corrected D3 & E3 dimensions. Updated datasheet's Head/Footer.	3/3/10
B	T1  T2B T3	2 2 3 4 6 8 12 -13 15	Pin Description Table, IREF description corrected 475ohm resistor to 950ohm. Corrected <i>Output Driver Current and diagram</i> . Differential DC Characteristics Table - updated notes. Added note, "Characterized using....". Added <i>Propagation Delay</i> diagram and corrected <i>HCSL Output Load AC Test Circuit</i> diagram in Parameter Measurement Information section. Updated <i>Wiring the Differential Input to Accept Single-ended Levels</i> . Corrected power dissipation calculation and total power dissipation section. Corrected <i>HCSL Driver Circuit Termination</i> diagram. Updated <i>Package Outline</i> . Converted datasheet format.	8/24/10
C	   T7	 8 8 10 16	Updated header/footer throughout the datasheet. Deleted <i>IDT</i> prefix from part number. Application Information: updated <i>Wiring the Differential Input to Accept Single-ended Levels</i> , updated <i>Recommend Termination</i> Ordering Information Table - deleted: leaded part rows and table note.	11/03/15



## IMPORTANT NOTICE AND DISCLAIMER

RENESAS ELECTRONICS CORPORATION AND ITS SUBSIDIARIES (“RENESAS”) PROVIDES TECHNICAL SPECIFICATIONS AND RELIABILITY DATA (INCLUDING DATASHEETS), DESIGN RESOURCES (INCLUDING REFERENCE DESIGNS), APPLICATION OR OTHER DESIGN ADVICE, WEB TOOLS, SAFETY INFORMATION, AND OTHER RESOURCES “AS IS” AND WITH ALL FAULTS, AND DISCLAIMS ALL WARRANTIES, EXPRESS OR IMPLIED, INCLUDING, WITHOUT LIMITATION, ANY IMPLIED WARRANTIES OF MERCHANTABILITY, FITNESS FOR A PARTICULAR PURPOSE, OR NON-INFRINGEMENT OF THIRD-PARTY INTELLECTUAL PROPERTY RIGHTS.

These resources are intended for developers who are designing with Renesas products. You are solely responsible for (1) selecting the appropriate products for your application, (2) designing, validating, and testing your application, and (3) ensuring your application meets applicable standards, and any other safety, security, or other requirements. These resources are subject to change without notice. Renesas grants you permission to use these resources only to develop an application that uses Renesas products. Other reproduction or use of these resources is strictly prohibited. No license is granted to any other Renesas intellectual property or to any third-party intellectual property. Renesas disclaims responsibility for, and you will fully indemnify Renesas and its representatives against, any claims, damages, costs, losses, or liabilities arising from your use of these resources. Renesas' products are provided only subject to Renesas' Terms and Conditions of Sale or other applicable terms agreed to in writing. No use of any Renesas resources expands or otherwise alters any applicable warranties or warranty disclaimers for these products.

(Disclaimer Rev.1.01)

### Corporate Headquarters

TOYOSU FORESIA, 3-2-24 Toyosu,  
Koto-ku, Tokyo 135-0061, Japan  
[www.renesas.com](http://www.renesas.com)

### Trademarks

Renesas and the Renesas logo are trademarks of Renesas Electronics Corporation. All trademarks and registered trademarks are the property of their respective owners.

### Contact Information

For further information on a product, technology, the most up-to-date version of a document, or your nearest sales office, please visit [www.renesas.com/contact-us/](http://www.renesas.com/contact-us/).