

## Programmable Timing Control Hub™ for P4™

### Recommended Application:

VIA P4X/P4M/KT/KN266/333 style chipsets.

### Output Features:

- 1 - Pair of differential CPU clocks @ 3.3V (CK408)/  
1 - Pair of differential open drain CPU clocks (K7)
- 1 - Pair of differential push pull CPU\_CS clocks @ 2.5V
- 3 - AGP @ 3.3V
- 7 - PCI @ 3.3V
- 1 - 48MHz @ 3.3V fixed
- 1 - 24\_48MHz @ 3.3V
- 2 - REF @ 3.3V, 14.318MHz

### Key Specifications:

- CPU\_CS - CPUC/C: <math>\lt; \pm 250\text{ps}</math>
- CPU\_CS - AGP: <math>\lt; \pm 250\text{ps}</math>
- CPU - DDR: <math>\lt; \pm 250\text{ps}</math>
- PCI - PCI: <math>\lt; 500\text{ps}</math>
- CPU - PCI: Min = 1.0ns, Typ = 2.0ns, Max = 4.0ns

### Features/Benefits:

- Programmable output frequency.
- Programmable output divider ratios.
- Programmable output rise/fall time.
- Programmable output skew.
- Programmable spread percentage for EMI control.
- DDR output buffer supports up to 200MHz.
- Watchdog timer technology to reset system if system malfunctions.
- Programmable watch dog safe frequency.
- Support I<sup>2</sup>C Index read/write and block read/write operations.
- Uses external 14.318MHz crystal.

### Frequency Table

| Bit2 | Bit7 | Bit6 | Bit5 | Bit4 | CPU    | AGP   | PCI   | Spread %             |
|------|------|------|------|------|--------|-------|-------|----------------------|
|      | FS3  | FS2  | FS1  | FS0  | MHz    | MHz   | MHz   |                      |
| 1    | 0    | 0    | 0    | 0    | 105.00 | 70.00 | 35.00 | 0.3 % Center Spread  |
| 1    | 0    | 0    | 0    | 1    | 140.00 | 70.00 | 35.00 | 0.3 % Center Spread  |
| 1    | 0    | 0    | 1    | 0    | 210.00 | 70.00 | 35.00 | 0.3 % Center Spread  |
| 1    | 0    | 0    | 1    | 1    | 174.99 | 70.00 | 35.00 | 0.3 % Center Spread  |
| 1    | 0    | 1    | 0    | 0    | 80.00  | 53.34 | 26.66 | 0.3 % Center Spread  |
| 1    | 0    | 1    | 0    | 1    | 106.66 | 53.34 | 26.66 | 0.3 % Center Spread  |
| 1    | 0    | 1    | 1    | 0    | 160.00 | 53.34 | 26.66 | 0.3 % Center Spread  |
| 1    | 0    | 1    | 1    | 1    | 133.33 | 53.34 | 26.66 | 0.3 % Center Spread  |
| 1    | 1    | 1    | 0    | 0    | 100.00 | 66.67 | 33.33 | 0.3 % Center Spread  |
| 1    | 1    | 1    | 0    | 1    | 133.33 | 66.67 | 33.33 | 0.3 % Center Spread  |
| 1    | 1    | 1    | 1    | 0    | 200.00 | 66.67 | 33.33 | 0.3 % Center Spread  |
| 1    | 1    | 1    | 1    | 1    | 166.66 | 66.67 | 33.33 | 0.3 % Center Spread  |
| 1    | 1    | 0    | 0    | 0    | 100.00 | 66.67 | 33.33 | 0 - 0.6% Down Spread |
| 1    | 1    | 0    | 0    | 1    | 133.33 | 66.67 | 33.33 | 0 - 0.6% Down Spread |
| 1    | 1    | 0    | 1    | 0    | 200.00 | 66.67 | 33.33 | 0 - 0.6% Down Spread |
| 1    | 1    | 0    | 1    | 1    | 166.66 | 66.67 | 33.33 | 0 - 0.6% Down Spread |

| MULTISEL0 | Board Target Trace/Term Z | Reference R, Iref = $V_{DD}/(3 \cdot R_r)$ | Output Current  | Voh @ Z   |
|-----------|---------------------------|--------------------------------------------|-----------------|-----------|
| 0         | 50 ohms                   | Rr = 221 1%, Iref = 5.00mA                 | Ioh = 4 * I REF | 1.0V @ 50 |
| 1         | 50 ohms                   | Rr = 475 1%, Iref = 2.32mA                 | Ioh = 6 * I REF | 0.7V @ 50 |

### Pin Configuration

|                     |    |    |                  |
|---------------------|----|----|------------------|
| *FS0/REF0           | 1  | 56 | Vtt_PWRGD#/REF1  |
| GND                 | 2  | 55 | VDDREF           |
| X1                  | 3  | 54 | GND              |
| X2                  | 4  | 53 | CPUCLK/CPUCLKODT |
| VDDAGP              | 5  | 52 | CPUCLK/CPUCLKODC |
| *MODE/AGPCLK0       | 6  | 51 | VDDCPU3.3        |
| *SEL_408/K7/AGPCLK1 | 7  | 50 | VDDCPU2.5        |
| *(PCI_STOP#)AGPCLK2 | 8  | 49 | CPUC_CS          |
| GNDAGP              | 9  | 48 | CPUT_CS          |
| **FS1/PCICLK_F      | 10 | 47 | GND              |
| ***PCICLK1          | 11 | 46 | FBOUT            |
| *MULTSEL/PCICLK2    | 12 | 45 | BUF_IN           |
| GNDPCI              | 13 | 44 | DDRT0            |
| PCICLK3             | 14 | 43 | DDRC0            |
| PCICLK4             | 15 | 42 | DDRT1            |
| VDDPCI              | 16 | 41 | DDRC1            |
| PCICLK5             | 17 | 40 | VDD2.5           |
| *(CLK_STOP#)PCICLK6 | 18 | 39 | GND              |
| GND48               | 19 | 38 | DDRT2            |
| *FS3/48MHz          | 20 | 37 | DDRC2            |
| *FS2/24_48MHz       | 21 | 36 | DDRT3            |
| AVDD48              | 22 | 35 | DDRC3            |
| VDD                 | 23 | 34 | VDD2.5           |
| GND                 | 24 | 33 | GND              |
| IREF                | 25 | 32 | DDRT4            |
| *(PD#)RESET#        | 26 | 31 | DDRC4            |
| SCLK                | 27 | 30 | DDRT5            |
| SDATA               | 28 | 29 | DDRC5            |

### 56-SSOP

\* Internal Pull-Up Resistor

\*\* Internal Pull-Down Resistor

\*\*\* A 120k pull-down resistor to GND is needed on this pin.

## Pin Description

| PIN # | PIN NAME            | PIN TYPE | DESCRIPTION                                                                                                                                                                                                                                                     |
|-------|---------------------|----------|-----------------------------------------------------------------------------------------------------------------------------------------------------------------------------------------------------------------------------------------------------------------|
| 1     | *FS0/REF0           | I/O      | Frequency select latch input pin / 14.318 MHz reference clock.                                                                                                                                                                                                  |
| 2     | GND                 | PWR      | Ground pin.                                                                                                                                                                                                                                                     |
| 3     | X1                  | IN       | Crystal input, Nominally 14.318MHz.                                                                                                                                                                                                                             |
| 4     | X2                  | OUT      | Crystal output, Nominally 14.318MHz                                                                                                                                                                                                                             |
| 5     | VDDAGP              | PWR      | Power supply for AGP clocks, nominal 3.3V                                                                                                                                                                                                                       |
| 6     | *MODE/AGPCLK0       | I/O      | Function select latch input pin, 1=Desktop Mode, 0=Mobile Mode / AGP clock output.                                                                                                                                                                              |
| 7     | *SEL_408/K7/AGPCLK1 | I/O      | CPU output type select latch input pin 0= K7, 1= CK408 / AGP clock output.                                                                                                                                                                                      |
| 8     | *(PCI_STOP#)AGPCLK2 | I/O      | Stops all PCICLKs besides the PCICLK_F clocks at logic 0 level, when input low. This input is activated by the MODE selection pin / AGP clock output.                                                                                                           |
| 9     | GNDAGP              | PWR      | Ground pin for the AGP outputs                                                                                                                                                                                                                                  |
| 10    | **FS1/PCICLK_F      | I/O      | Frequency select latch input pin / 3.3V PCI free running clock output.                                                                                                                                                                                          |
| 11    | ***PCICLK1          | I/O      | Memory type select latch input pin 0= DDR, 1= PC133 SDRAM / 3.3V PCI clock output.                                                                                                                                                                              |
| 12    | *MULTSEL/PCICLK2    | I/O      | 3.3V LVTTTL input for selection the current multiplier for CPU outputs / 3.3V PCI clock output.                                                                                                                                                                 |
| 13    | GNDPCI              | PWR      | Ground pin for the PCI outputs                                                                                                                                                                                                                                  |
| 14    | PCICLK3             | OUT      | PCI clock output.                                                                                                                                                                                                                                               |
| 15    | PCICLK4             | OUT      | PCI clock output.                                                                                                                                                                                                                                               |
| 16    | VDDPCI              | PWR      | Power supply for PCI clocks, nominal 3.3V                                                                                                                                                                                                                       |
| 17    | PCICLK5             | OUT      | PCI clock output.                                                                                                                                                                                                                                               |
| 18    | *(CLK_STOP#)PCICLK6 | I/O      | Stops all CPU, DDR/SDRAM and FB_OUT clocks at logic 0 level, when input low. This input is activated by the MODE selection pin / PCI clock output.                                                                                                              |
| 19    | GND48               | PWR      | Ground pin for the 48MHz outputs                                                                                                                                                                                                                                |
| 20    | *FS3/48MHz          | I/O      | Frequency select latch input pin / Fixed 48MHz clock output. 3.3V                                                                                                                                                                                               |
| 21    | *FS2/24_48MHz       | I/O      | Frequency select latch input pin / Fixed 24 or 48MHz clock output. 3.3V.                                                                                                                                                                                        |
| 22    | AVDD48              | PWR      | Power for 24/48MHz outputs and fixed PLL core, nominal 3.3V                                                                                                                                                                                                     |
| 23    | VDD                 | PWR      | Power supply, nominal 3.3V                                                                                                                                                                                                                                      |
| 24    | GND                 | PWR      | Ground pin.                                                                                                                                                                                                                                                     |
| 25    | IREF                | OUT      | This pin establishes the reference current for the CPUCLK pairs. This pin requires a fixed precision resistor tied to ground in order to establish the appropriate current.                                                                                     |
| 26    | *(PD#)RESET#        | I/O      | Asynchronous active low input pin used to power down the device into a low power state. This input is activated by the MODE selection pin / Real time system reset signal for frequency gear ratio change or watchdog timer timeout. This signal is active low. |
| 27    | SCLK                | IN       | Clock pin of I2C circuitry 5V tolerant                                                                                                                                                                                                                          |
| 28    | SDATA               | I/O      | Data pin for I2C circuitry 5V tolerant                                                                                                                                                                                                                          |

\* Internal Pull-Up Resistor

\*\* Internal Pull-Down Resistor

\*\*\* A 120k pull-down resistor to GND is needed on this pin.

Pin Description (Continued)

| PIN # | PIN NAME          | PIN TYPE | DESCRIPTION                                                                                                                                                                                                                                                                          |
|-------|-------------------|----------|--------------------------------------------------------------------------------------------------------------------------------------------------------------------------------------------------------------------------------------------------------------------------------------|
| 29    | DDRC5             | OUT      | "Complimentary" Clock of differential pair output.                                                                                                                                                                                                                                   |
| 30    | DDRT5             | OUT      | "True" Clock of differential pair output.                                                                                                                                                                                                                                            |
| 31    | DDRC4             | OUT      | "Complimentary" Clock of differential pair output.                                                                                                                                                                                                                                   |
| 32    | DDRT4             | OUT      | "True" Clock of differential pair output.                                                                                                                                                                                                                                            |
| 33    | GND               | PWR      | Ground pin.                                                                                                                                                                                                                                                                          |
| 34    | VDD2.5            | PWR      | Power supply, nominal 2.5V                                                                                                                                                                                                                                                           |
| 35    | DDRC3             | OUT      | "Complimentary" Clock of differential pair output.                                                                                                                                                                                                                                   |
| 36    | DDRT3             | OUT      | "True" Clock of differential pair output.                                                                                                                                                                                                                                            |
| 37    | DDRC2             | OUT      | "Complimentary" Clock of differential pair output.                                                                                                                                                                                                                                   |
| 38    | DDRT2             | OUT      | "True" Clock of differential pair output.                                                                                                                                                                                                                                            |
| 39    | GND               | PWR      | Ground pin.                                                                                                                                                                                                                                                                          |
| 40    | VDD2.5            | PWR      | Power supply, nominal 2.5V                                                                                                                                                                                                                                                           |
| 41    | DDRC1             | OUT      | "Complimentary" Clock of differential pair output.                                                                                                                                                                                                                                   |
| 42    | DDRT1             | OUT      | "True" Clock of differential pair output.                                                                                                                                                                                                                                            |
| 43    | DDRC0             | OUT      | "Complimentary" Clock of differential pair output.                                                                                                                                                                                                                                   |
| 44    | DDRT0             | OUT      | "True" Clock of differential pair output.                                                                                                                                                                                                                                            |
| 45    | BUF_IN            | IN       | Input Buffers for memory outputs.                                                                                                                                                                                                                                                    |
| 46    | FBOUT             | OUT      | Memory feed back output.                                                                                                                                                                                                                                                             |
| 47    | GND               | PWR      | Ground pin.                                                                                                                                                                                                                                                                          |
| 48    | CPUT_CS           | OUT      | True clock of differential pair 2.5V push-pull CPU outputs.                                                                                                                                                                                                                          |
| 49    | CPUC_CS           | OUT      | Complimentary" clocks of differential pair 2.5V push-pull CPU outputs.                                                                                                                                                                                                               |
| 50    | VDDCPU2.5         | PWR      | Power pin for the CPUCLKs. 2.5V                                                                                                                                                                                                                                                      |
| 51    | VDDCPU3.3         | PWR      | Power pin for the CPUCLKs. 3.3V                                                                                                                                                                                                                                                      |
| 52    | CPUCLKC/CPUCLKODC | OUT      | "Complementary" clocks of differential pair CPU outputs. These are current mode outputs. External resistors are required for voltage bias / "Complementary" clocks of differential pair CPU outputs. These open drain outputs need an external 1.5V pull-up / 2.5V CPU clock output. |
| 53    | CPUCLKT/CPUCLKODT | OUT      | "True" clocks of differential pair CPU outputs. These are current mode outputs. External resistors are required for voltage bias / "True" clocks of differential pair CPU outputs. These open drain outputs need an external 1.5V pull-up / 2.5V CPU clock output.                   |
| 54    | GND               | PWR      | Ground pin.                                                                                                                                                                                                                                                                          |
| 55    | VDDREF            | PWR      | Ref, XTAL power supply, nominal 3.3V                                                                                                                                                                                                                                                 |
| 56    | Vtt_PWRGD#**/REF1 | IN       | This 3.3V LVTTTL input is a level sensitive strobe used to determine when latch inputs are valid and are ready to be sampled. This is an active low input. / 14.318 MHz reference clock.                                                                                             |

## General Description

The **ICS950910** is a single chip clock solution for desktop designs using the VIA P4X/P4M/KT/KN266/333 style chipsets with PC133 or DDR memory.

The **ICS950910** is part of a whole new line of ICS clock generators and buffers called TCH™ (Timing Control Hub). This part incorporates ICS's newest clock technology which offers more robust features and functionality. Employing the use of a serially programmable I<sup>2</sup>C interface, this device can adjust the output clocks by configuring the frequency setting, the output divider ratios, selecting the ideal spread percentage, the output skew, the output strength, and enabling/disabling each individual output clock. M/N control can configure output frequency with resolution up to 0.1MHz increment.

## Block Diagram

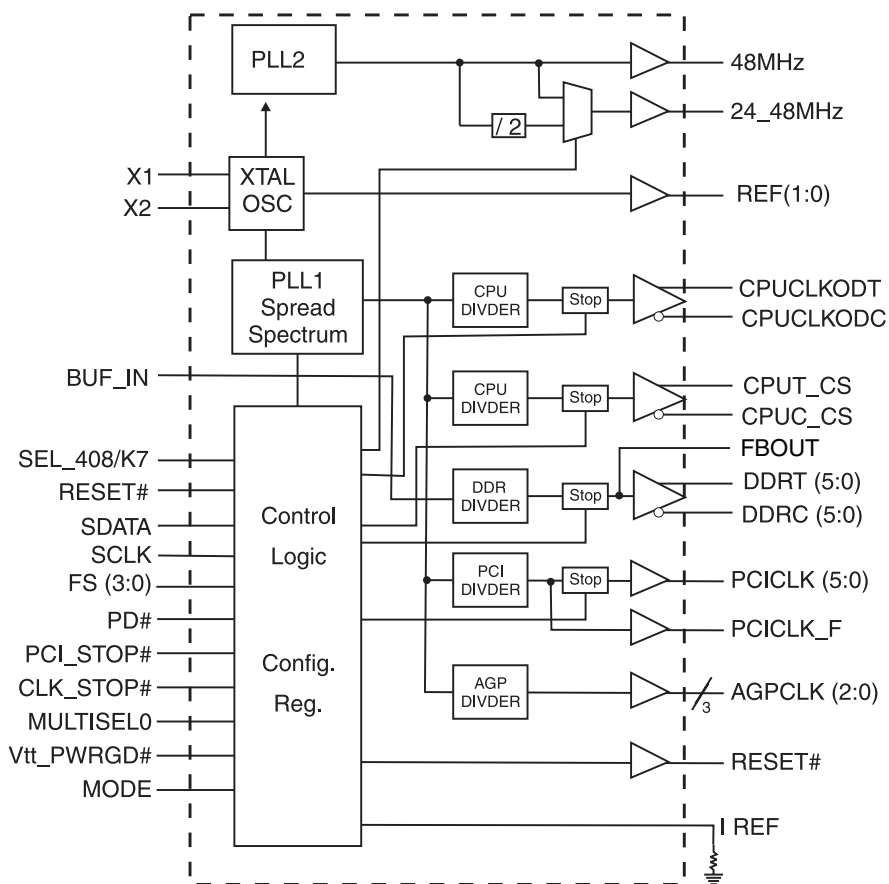

## Power Groups

| Pin Number |        | Description                     |
|------------|--------|---------------------------------|
| VDD        | GND    |                                 |
| 55         | 2      | Xtal, Ref                       |
| 5          | 9      | AGP [0:2], CPU digital, CPU PLL |
| 16         | 13     | PCI [0:5], PCI_F outputs        |
| 22         | 19     | 48MHz, Fix Digital, Fix Analog  |
| 23         | 24     | Master clock, CPU Analog        |
| 34, 40     | 33, 39 | DDR/SDR outputs                 |
| 50         | 47     | 2.5V CPUT/C_CS output           |
| 51         | 54     | 3.3V CPUT/C & CPUOD_T/C         |

## General I<sup>2</sup>C serial interface information

### How to Write:

- Controller (host) sends a start bit.
- Controller (host) sends the write address D2<sub>(H)</sub>
- ICS clock will **acknowledge**
- Controller (host) sends the beginning byte location = N
- ICS clock will **acknowledge**
- Controller (host) sends the data byte count = X
- ICS clock will **acknowledge**
- Controller (host) starts sending **Byte N through Byte N + X - 1**  
(see Note 2)
- ICS clock will **acknowledge** each byte **one at a time**
- Controller (host) sends a Stop bit

| Index Block Write Operation     |           |                      |
|---------------------------------|-----------|----------------------|
| Controller (Host)               |           | ICS (Slave/Receiver) |
| T                               | starT bit |                      |
| Slave Address D2 <sub>(H)</sub> |           |                      |
| WR                              | WRite     |                      |
|                                 |           | ACK                  |
| Beginning Byte = N              |           |                      |
|                                 |           | ACK                  |
| Data Byte Count = X             |           |                      |
|                                 |           | ACK                  |
| Beginning Byte N                |           | X Byte               |
| ○                               |           |                      |
| ○                               |           |                      |
| ○                               |           |                      |
| Byte N + X - 1                  |           |                      |
|                                 |           | ACK                  |
| P                               | stoP bit  |                      |

### How to Read:

- Controller (host) will send start bit.
- Controller (host) sends the write address D2<sub>(H)</sub>
- ICS clock will **acknowledge**
- Controller (host) sends the beginning byte location = N
- ICS clock will **acknowledge**
- Controller (host) will send a separate start bit.
- Controller (host) sends the read address D3<sub>(H)</sub>
- ICS clock will **acknowledge**
- ICS clock will send the data byte count = X
- ICS clock sends **Byte N + X - 1**
- ICS clock sends **Byte 0 through byte X (if X<sub>(H)</sub> was written to byte 8)**.
- Controller (host) will need to acknowledge each byte
- Controller (host) will send a not acknowledge bit
- Controller (host) will send a stop bit

| Index Block Read Operation      |                 |                      |
|---------------------------------|-----------------|----------------------|
| Controller (Host)               |                 | ICS (Slave/Receiver) |
| T                               | starT bit       |                      |
| Slave Address D2 <sub>(H)</sub> |                 |                      |
| WR                              | WRite           |                      |
|                                 |                 | ACK                  |
| Beginning Byte = N              |                 |                      |
|                                 |                 | ACK                  |
| RT                              | Repeat starT    |                      |
| Slave Address D3 <sub>(H)</sub> |                 |                      |
| RD                              | ReaD            |                      |
|                                 |                 | ACK                  |
|                                 |                 | Data Byte Count = X  |
| ACK                             |                 |                      |
| ACK                             |                 | X Byte               |
|                                 |                 |                      |
| ○                               |                 |                      |
| ○                               |                 |                      |
| ○                               |                 |                      |
|                                 |                 | Byte N + X - 1       |
| N                               | Not acknowledge |                      |
| P                               | stoP bit        |                      |

\*See notes on the following page.

0735B—09/21/07

**Byte 0: Functionality and frequency select register (Default=0)**

| Bit            | Description                                                                                            |      |      |      |        |               |               |                      |                         | PWD    |
|----------------|--------------------------------------------------------------------------------------------------------|------|------|------|--------|---------------|---------------|----------------------|-------------------------|--------|
| Bit            | Bit2                                                                                                   | Bit7 | Bit6 | Bit5 | Bit4   | CPUCLK<br>MHz | AGPCLK<br>MHz | PCICLK<br>MHz        | Spread %                |        |
|                | FS3                                                                                                    | FS2  | FS1  | FS0  |        |               |               |                      |                         |        |
| Bit<br>(2,7:4) | 0                                                                                                      | 0    | 0    | 0    | 0      | 102.00        | 68.00         | 34.00                | +/- 0.30% Center Spread | Note 1 |
|                | 0                                                                                                      | 0    | 0    | 0    | 1      | 105.00        | 70.00         | 35.00                | +/- 0.30% Center Spread |        |
|                | 0                                                                                                      | 0    | 0    | 1    | 0      | 108.00        | 72.00         | 36.00                | +/- 0.30% Center Spread |        |
|                | 0                                                                                                      | 0    | 0    | 1    | 1      | 111.00        | 74.00         | 27.00                | +/- 0.30% Center Spread |        |
|                | 0                                                                                                      | 0    | 1    | 0    | 0      | 114.00        | 76.00         | 38.00                | +/- 0.30% Center Spread |        |
|                | 0                                                                                                      | 0    | 1    | 0    | 1      | 117.00        | 78.00         | 39.00                | +/- 0.30% Center Spread |        |
|                | 0                                                                                                      | 0    | 1    | 1    | 0      | 120.00        | 80.00         | 40.00                | +/- 0.30% Center Spread |        |
|                | 0                                                                                                      | 0    | 1    | 1    | 1      | 123.00        | 82.00         | 41.00                | +/- 0.30% Center Spread |        |
|                | 0                                                                                                      | 1    | 0    | 0    | 0      | 126.00        | 72.00         | 36.00                | +/- 0.30% Center Spread |        |
|                | 0                                                                                                      | 1    | 0    | 0    | 1      | 130.00        | 74.30         | 37.10                | +/- 0.30% Center Spread |        |
|                | 0                                                                                                      | 1    | 0    | 1    | 0      | 133.90        | 66.95         | 33.48                | +/- 0.30% Center Spread |        |
|                | 0                                                                                                      | 1    | 0    | 1    | 1      | 140.00        | 70.00         | 35.00                | +/- 0.30% Center Spread |        |
|                | 0                                                                                                      | 1    | 1    | 0    | 0      | 144.00        | 72.00         | 36.00                | +/- 0.30% Center Spread |        |
|                | 0                                                                                                      | 1    | 1    | 0    | 1      | 148.00        | 74.00         | 37.00                | +/- 0.30% Center Spread |        |
|                | 0                                                                                                      | 1    | 1    | 1    | 0      | 152.00        | 76.00         | 38.00                | +/- 0.30% Center Spread |        |
|                | 0                                                                                                      | 1    | 1    | 1    | 1      | 156.00        | 78.00         | 39.00                | +/- 0.30% Center Spread |        |
|                | 1                                                                                                      | 0    | 0    | 0    | 0      | 105.00        | 70.00         | 35.00                | 0.3 % Center Spread     |        |
|                | 1                                                                                                      | 0    | 0    | 0    | 1      | 140.00        | 70.00         | 35.00                | 0.3 % Center Spread     |        |
|                | 1                                                                                                      | 0    | 0    | 1    | 0      | 210.00        | 70.00         | 35.00                | 0.3 % Center Spread     |        |
|                | 1                                                                                                      | 0    | 0    | 1    | 1      | 174.99        | 70.00         | 35.00                | 0.3 % Center Spread     |        |
|                | 1                                                                                                      | 0    | 1    | 0    | 0      | 80.00         | 53.34         | 26.66                | 0.3 % Center Spread     |        |
|                | 1                                                                                                      | 0    | 1    | 0    | 1      | 106.66        | 53.34         | 26.66                | 0.3 % Center Spread     |        |
|                | 1                                                                                                      | 0    | 1    | 1    | 0      | 160.00        | 53.34         | 26.66                | 0.3 % Center Spread     |        |
|                | 1                                                                                                      | 0    | 1    | 1    | 1      | 133.33        | 53.34         | 26.66                | 0.3 % Center Spread     |        |
| 1              | 1                                                                                                      | 1    | 0    | 0    | 100.00 | 66.67         | 33.33         | 0.3 % Center Spread  |                         |        |
| 1              | 1                                                                                                      | 1    | 0    | 1    | 133.33 | 66.67         | 33.33         | 0.3 % Center Spread  |                         |        |
| 1              | 1                                                                                                      | 1    | 1    | 0    | 200.00 | 66.67         | 33.33         | 0.3 % Center Spread  |                         |        |
| 1              | 1                                                                                                      | 1    | 1    | 1    | 166.66 | 66.67         | 33.33         | 0.3 % Center Spread  |                         |        |
| 1              | 1                                                                                                      | 0    | 0    | 0    | 100.00 | 66.67         | 33.33         | 0 - 0.6% Down Spread |                         |        |
| 1              | 1                                                                                                      | 0    | 0    | 1    | 133.33 | 66.67         | 33.33         | 0 - 0.6% Down Spread |                         |        |
| 1              | 1                                                                                                      | 0    | 1    | 0    | 200.00 | 66.67         | 33.33         | 0 - 0.6% Down Spread |                         |        |
| 1              | 1                                                                                                      | 0    | 1    | 1    | 166.66 | 66.67         | 33.33         | 0 - 0.6% Down Spread |                         |        |
| Bit 3          | 0 - Frequency is selected by hardware select, latched inputs<br>1 - Frequency is selected by Bit 2,7:4 |      |      |      |        |               |               |                      |                         | 0      |
| Bit 1          | 0 - Normal<br>1 - Spread spectrum enable                                                               |      |      |      |        |               |               |                      |                         | 1      |
| Bit 0          | 0 - Running<br>1 - Tristate all outputs                                                                |      |      |      |        |               |               |                      |                         | 0      |

**Notes:**

1. Default at power-up will be for latched logic inputs to define frequency, as displayed by Bit 3.

**Mode Pin - Power Management Input Control**

| MODE, Pin 6<br>(Latched Input) | Pin 26             | Pin 18               | Pin 8                |
|--------------------------------|--------------------|----------------------|----------------------|
| 0                              | PD#<br>(Input)     | CPU_STOP#<br>(Input) | PCI_STOP#<br>(Input) |
| 1                              | RESET#<br>(Output) | PCICLK5<br>(Output)  | AGP2<br>(Output)     |

**Byte 1: CPU Active/Inactive Register**  
(1 = enable, 0 = disable)

| Bit  | Pin#   | PWD | Description                    |
|------|--------|-----|--------------------------------|
| Bit7 | 29     | 1   | DDRC5 (Active/Inactive)        |
| Bit6 | 10     | 1   | PCICLK_F (Active/Inactive)     |
| Bit5 | 30     | 1   | DDRT5 (Active/Inactive)        |
| Bit4 | 31     | 1   | DDRC4 (Active/Inactive)        |
| Bit3 | -      | 1   | (Reserved)                     |
| Bit2 | 32     | 1   | DDRT4 (Active/Inactive)        |
| Bit1 | 53, 52 | 1   | CPUCLKT/C_CS (Active/Inactive) |
| Bit0 | 48, 49 | 1   | CPUCLKT/C_CS (Active/Inactive) |

**Byte 2: PCI Active/Inactive Register**  
(1 = enable, 0 = disable)

| Bit  | Pin#   | PWD | Description                                                            |
|------|--------|-----|------------------------------------------------------------------------|
| Bit7 | 46     | 1   | FB_OUT Free running control; 1 = free running; 0 = not free running    |
| Bit6 | 18     | 1   | PCICLK6 (Active/Inactive)                                              |
| Bit5 | 17     | 1   | PCICLK5 (Active/Inactive)                                              |
| Bit4 | 15     | 1   | PCICLK4 (Active/Inactive)                                              |
| Bit3 | 14     | 1   | PCICLK3 (Active/Inactive)                                              |
| Bit2 | 12     | 1   | PCICLK2 (Active/Inactive)                                              |
| Bit1 | 11     | 1   | PCICLK1 (Active/Inactive)                                              |
| Bit0 | 53, 52 | 1   | CPUCLKT/C Free running control; 1 = free running; 0 = not free running |

**Byte 3: Active/Inactive Register**  
(1 = enable, 0 = disable)

| Bit  | Pin#   | PWD | Description                                                          |
|------|--------|-----|----------------------------------------------------------------------|
| Bit7 | 46     | 1   | FB_OUT (Active/Inactive)                                             |
| Bit6 | -      | 1   | SEL 24_48, 0=24Mhz 1=48MHz                                           |
| Bit5 | -      | 1   | DDR free running control; 1 = free running; 0 not free running       |
| Bit4 | 56     | 1   | REF1 (Active/Inactive)                                               |
| Bit3 | 48, 49 | 1   | CPUC/T_CS free running control; 1 = free running; 0 not free running |
| Bit2 | 8      | 1   | AGPCLK 2 (Active/Inactive)                                           |
| Bit1 | 7      | 1   | AGPCLK 1 (Active/Inactive)                                           |
| Bit0 | 6      | 1   | AGPCLK 0 (Active/Inactive)                                           |

**Byte 4: Frequency Select Active/Inactive Register**  
(1 = enable, 0 = disable)

| Bit   | Pin# | PWD | Description                |
|-------|------|-----|----------------------------|
| Bit 7 | -    | X   | Latched FS3                |
| Bit 6 | -    | X   | Latched FS2                |
| Bit 5 | -    | X   | Latched FS1                |
| Bit 4 | -    | X   | Latched FS0                |
| Bit 3 | 20   | 1   | 48MHz (Active/Inactive)    |
| Bit 2 | 21   | 1   | 24_48MHz (Active/Inactive) |
| Bit 1 | -    | -   | (Reserved)                 |
| Bit 0 | 1    | 1   | REF0 (Active/Inactive)     |

**Byte 5: Peripheral Active/Inactive Register**  
(1 = enable, 0 = disable)

| Bit   | Pin# | PWD | Description             |
|-------|------|-----|-------------------------|
| Bit 7 | 35   | 1   | DDRC3 (Active/Inactive) |
| Bit 6 | 36   | 1   | DDRT3 (Active/Inactive) |
| Bit 5 | 37   | 1   | DDRC2 (Active/Inactive) |
| Bit 4 | 38   | 1   | DDRT2 (Active/Inactive) |
| Bit 3 | 41   | 1   | DDRC1 (Active/Inactive) |
| Bit 2 | 42   | 1   | DDRT1 (Active/Inactive) |
| Bit 1 | 43   | 1   | DDRC0 (Active/Inactive) |
| Bit 0 | 44   | 1   | DDRT0 (Active/Inactive) |

**Byte 6: Vendor ID Register**  
(1 = enable, 0 = disable)

| Bit   | Name             | PWD | Description                                                      |
|-------|------------------|-----|------------------------------------------------------------------|
| Bit 7 | Revision ID Bit3 | X   | Revision ID values will be based on individual device's revision |
| Bit 6 | Revision ID Bit2 | X   |                                                                  |
| Bit 5 | Revision ID Bit1 | X   |                                                                  |
| Bit 4 | Revision ID Bit0 | X   |                                                                  |
| Bit 3 | Vendor ID Bit3   | 0   | (Reserved)                                                       |
| Bit 2 | Vendor ID Bit2   | 0   | (Reserved)                                                       |
| Bit 1 | Vendor ID Bit1   | 0   | (Reserved)                                                       |
| Bit 0 | Vendor ID Bit0   | 1   | (Reserved)                                                       |

**Byte 7: Revision ID and Device ID Register**

| Bit   | Name       | PWD | Description                                                             |
|-------|------------|-----|-------------------------------------------------------------------------|
| Bit 7 | Device ID7 | 0   | Device ID values will be based on individual device "01h" in this case. |
| Bit 6 | Device ID6 | 0   |                                                                         |
| Bit 5 | Device ID5 | 0   |                                                                         |
| Bit 4 | Device ID4 | 1   |                                                                         |
| Bit 3 | Device ID3 | 0   |                                                                         |
| Bit 2 | Device ID2 | 1   |                                                                         |
| Bit 1 | Device ID1 | 1   |                                                                         |
| Bit 0 | Device ID0 | 1   |                                                                         |

**Byte 8: Byte Count Read Back Register**

| Bit   | Name  | PWD | Description                                                                                                                           |
|-------|-------|-----|---------------------------------------------------------------------------------------------------------------------------------------|
| Bit 7 | Byte7 | 0   | Note: Writing to this register will configure byte count and how many bytes will be read back, default is 0F <sub>H</sub> = 15 bytes. |
| Bit 6 | Byte6 | 0   |                                                                                                                                       |
| Bit 5 | Byte5 | 0   |                                                                                                                                       |
| Bit 4 | Byte4 | 0   |                                                                                                                                       |
| Bit 3 | Byte3 | 1   |                                                                                                                                       |
| Bit 2 | Byte2 | 1   |                                                                                                                                       |
| Bit 1 | Byte1 | 1   |                                                                                                                                       |
| Bit 0 | Byte0 | 1   |                                                                                                                                       |

**Byte 9: Watchdog Timer Count Register**

| Bit   | Name | PWD | Description                                                                                                                                                                                                                |
|-------|------|-----|----------------------------------------------------------------------------------------------------------------------------------------------------------------------------------------------------------------------------|
| Bit 7 | WD7  | 0   | The decimal representation of these 8 bits correspond to X • 290ms the watchdog timer will wait before it goes to alarm mode and reset the frequency to the safe setting. Default at power up is 16 • 290ms = 4.6 seconds. |
| Bit 6 | WD6  | 0   |                                                                                                                                                                                                                            |
| Bit 5 | WD5  | 0   |                                                                                                                                                                                                                            |
| Bit 4 | WD4  | 1   |                                                                                                                                                                                                                            |
| Bit 3 | WD3  | 0   |                                                                                                                                                                                                                            |
| Bit 2 | WD2  | 0   |                                                                                                                                                                                                                            |
| Bit 1 | WD1  | 0   |                                                                                                                                                                                                                            |
| Bit 0 | WD0  | 0   |                                                                                                                                                                                                                            |

**Byte 10: Programming Enable bit 8 Watchdog Control Register**

| Bit   | Name           | PWD | Description                                                                                                                    |
|-------|----------------|-----|--------------------------------------------------------------------------------------------------------------------------------|
| Bit 7 | Program Enable | 0   | Programming Enable bit<br>0 = no programming. Frequencies are selected by HW latches or Byte0 1 = enable all PC programming.   |
| Bit 6 | WD Enable      | 0   | Software Watchdog Enable bit.<br>This bit will over write WDEN latched value. 0 = disable, 1 = Enable.                         |
| Bit 5 | WD Alarm       | 0   | Watchdog Alarm Status 0 = normal 1= alarm status                                                                               |
| Bit 4 | SF4            | 0   | Watchdog safe frequency bits. Writing to these bits will configure the safe frequency corresponding to Byte 0 Bit 2, 7:4 table |
| Bit 3 | SF3            | 0   |                                                                                                                                |
| Bit 2 | SF2            | 0   |                                                                                                                                |
| Bit 1 | SF1            | 0   |                                                                                                                                |
| Bit 0 | SF0            | 0   |                                                                                                                                |

**Byte 11: VCO Frequency M Divider (Reference divider) Control Register**

| Bit   | Name   | PWD | Description                                                                                                                                       |
|-------|--------|-----|---------------------------------------------------------------------------------------------------------------------------------------------------|
| Bit 7 | Ndiv 8 | X   | N divider bit 8                                                                                                                                   |
| Bit 6 | Mdiv 6 | X   | The decimal representation of Mdiv (6:0) correspond to the reference divider value. Default at power up is equal to the latched inputs selection. |
| Bit 5 | Mdiv 5 | X   |                                                                                                                                                   |
| Bit 4 | Mdiv 4 | X   |                                                                                                                                                   |
| Bit 3 | Mdiv 3 | X   |                                                                                                                                                   |
| Bit 2 | Mdiv 2 | X   |                                                                                                                                                   |
| Bit 1 | Mdiv 1 | X   |                                                                                                                                                   |
| Bit 0 | Mdiv 0 | X   |                                                                                                                                                   |

**Byte 12: VCO Frequency N Divider (VCO divider) Control Register**

| Bit   | Name   | PWD | Description                                                                                                                                                                      |
|-------|--------|-----|----------------------------------------------------------------------------------------------------------------------------------------------------------------------------------|
| Bit 7 | Ndiv 7 | X   | The decimal representation of Ndiv (8:0) correspond to the VCO divider value. Default at power up is equal to the latched inputs selection. Notice Ndiv 8 is located in Byte 11. |
| Bit 6 | Ndiv 6 | X   |                                                                                                                                                                                  |
| Bit 5 | Ndiv 5 | X   |                                                                                                                                                                                  |
| Bit 4 | Ndiv 4 | X   |                                                                                                                                                                                  |
| Bit 3 | Ndiv 3 | X   |                                                                                                                                                                                  |
| Bit 2 | Ndiv 2 | X   |                                                                                                                                                                                  |
| Bit 1 | Ndiv 1 | X   |                                                                                                                                                                                  |
| Bit 0 | Ndiv 0 | X   |                                                                                                                                                                                  |

**Byte 13: Spread Spectrum Control Register**

| Bit   | Name | PWD | Description                                                                                                                                                                                                                                                                                          |
|-------|------|-----|------------------------------------------------------------------------------------------------------------------------------------------------------------------------------------------------------------------------------------------------------------------------------------------------------|
| Bit 7 | SS 7 | X   | The Spread Spectrum (12:0) bit will program the spread percentage. Spread percent needs to be calculated based on the VCO frequency, spreading profile, spreading amount and spread frequency. It is recommended to use ICS software for spread programming. Default power on is latched FS divider. |
| Bit 6 | SS 6 | X   |                                                                                                                                                                                                                                                                                                      |
| Bit 5 | SS 5 | X   |                                                                                                                                                                                                                                                                                                      |
| Bit 4 | SS 4 | X   |                                                                                                                                                                                                                                                                                                      |
| Bit 3 | SS 3 | X   |                                                                                                                                                                                                                                                                                                      |
| Bit 2 | SS 2 | X   |                                                                                                                                                                                                                                                                                                      |
| Bit 1 | SS 1 | X   |                                                                                                                                                                                                                                                                                                      |
| Bit 0 | SS 0 | X   |                                                                                                                                                                                                                                                                                                      |

**Byte 14: Spread Spectrum Control Register**

| Bit   | Name     | PWD | Description            |
|-------|----------|-----|------------------------|
| Bit 7 | Reserved | X   | Reserved               |
| Bit 6 | Reserved | X   | Reserved               |
| Bit 5 | Reserved | X   | Reserved               |
| Bit 4 | SS 12    | X   | Spread Spectrum Bit 12 |
| Bit 3 | SS 11    | X   | Spread Spectrum Bit 11 |
| Bit 2 | SS 10    | X   | Spread Spectrum Bit 10 |
| Bit 1 | SS 9     | X   | Spread Spectrum Bit 9  |
| Bit 0 | SS 8     | X   | Spread Spectrum Bit 8  |

**Byte 15: Output Divider Control Register**

| Bit   | Name      | PWD | Description                                                                                                                                                                |
|-------|-----------|-----|----------------------------------------------------------------------------------------------------------------------------------------------------------------------------|
| Bit 7 | CPU Div 3 | 0   | CPUCLKC/T clock divider ratio can be configured via these 4 bits individually. For divider selection table refer to Table 1. Default at power up is latched FS divider.    |
| Bit 6 | CPU Div 2 | 1   |                                                                                                                                                                            |
| Bit 5 | CPU Div 1 | 0   |                                                                                                                                                                            |
| Bit 4 | CPU Div 0 | 1   |                                                                                                                                                                            |
| Bit 3 | CPU Div 3 | 0   | CPUCLKT/C_CS clock divider ratio can be configured via these 4 bits individually. For divider selection table refer to Table 1. Default at power up is latched FS divider. |
| Bit 2 | CPU Div 2 | 1   |                                                                                                                                                                            |
| Bit 1 | CPU Div 1 | 0   |                                                                                                                                                                            |
| Bit 0 | CPU Div 0 | 1   |                                                                                                                                                                            |

**Byte 16: Output Divider Control Register**

| Bit   | Name      | PWD | Description                                                                                                                                                       |
|-------|-----------|-----|-------------------------------------------------------------------------------------------------------------------------------------------------------------------|
| Bit 7 | AGP Div 3 | 0   | AGP clock divider ratio can be configured via these 4 bits individually. For divider selection table refer to Table 1. Default at power up is latched FS divider. |
| Bit 6 | AGP Div 2 | 1   |                                                                                                                                                                   |
| Bit 5 | AGP Div 1 | 0   |                                                                                                                                                                   |
| Bit 4 | AGP Div 0 | 1   |                                                                                                                                                                   |
| Bit 3 | Reserved  | -   | Reserved                                                                                                                                                          |
| Bit 2 | Reserved  | -   |                                                                                                                                                                   |
| Bit 1 | Reserved  | -   |                                                                                                                                                                   |
| Bit 0 | Reserved  | -   |                                                                                                                                                                   |

**Byte 17: Output Divider Control Register**

| Bit   | Name      | PWD | Description                                                                                                                                                       |
|-------|-----------|-----|-------------------------------------------------------------------------------------------------------------------------------------------------------------------|
| Bit 7 | AGP_INV   | 0   | AGP Phase Inversion bit                                                                                                                                           |
| Bit 6 | Reserved  | 0   | Reserved                                                                                                                                                          |
| Bit 5 | CPU_INV   | 0   | CPU T/C Phase Inversion bit                                                                                                                                       |
| Bit 4 | CPU_INV   | 0   | CPUT/C_CS Phase Inversion bit                                                                                                                                     |
| Bit 3 | PCI Div 3 | 1   | PCI clock divider ratio can be configured via these 4 bits individually. For divider selection table refer to Table 2. Default at power up is latched FS divider. |
| Bit 2 | PCI Div 2 | 0   |                                                                                                                                                                   |
| Bit 1 | PCI Div 1 | 0   |                                                                                                                                                                   |
| Bit 0 | PCI Div 0 | 1   |                                                                                                                                                                   |

**Table 1**

| Div (3:2) | 00 | 01  | 10  | 11  |
|-----------|----|-----|-----|-----|
| Div (1:0) |    |     |     |     |
| 00        | /2 | /4  | /8  | /16 |
| 01        | /3 | /6  | /12 | /24 |
| 10        | /5 | /10 | /20 | /40 |
| 11        | /7 | /14 | /28 | /56 |

**Table 2**

| Div (3:2) | 00 | 01  | 10  | 11  |
|-----------|----|-----|-----|-----|
| Div (1:0) |    |     |     |     |
| 00        | /4 | /8  | /16 | /32 |
| 01        | /3 | /6  | /12 | /24 |
| 10        | /5 | /10 | /20 | /40 |
| 11        | /9 | /18 | /36 | /72 |

**Byte 18: Group Skew Control Register**

| Bit   | Name                                  | PWD | Description                                                                                                      |
|-------|---------------------------------------|-----|------------------------------------------------------------------------------------------------------------------|
| Bit 7 | CPUCLKT/C_CS<br>Group Skew<br>Control | 1   | These 2 bits delay the CPUCLKT/C_CS with respect to CPUCLKT/C<br>00 = 0ps 01 = 250ps 10 = 500ps 11 = 750ps       |
| Bit 6 |                                       | 0   |                                                                                                                  |
| Bit 5 | CPUCLKT/C<br>Group Skew<br>Control    | 1   | These 2 bits delay the CPUCLKT/C clock with respect to CPUCLKT/C_CS<br>00 = 0ps 01 = 250ps 10 = 500ps 11 = 750ps |
| Bit 4 |                                       | 0   |                                                                                                                  |
| Bit 3 | AGPCLK<br>Group Skew<br>Control       | 1   | These 2 bits delay the AGPCLK clocks with respect to CPUCLK<br>00 = 0ps 01 = 250ps 10 = 500ps 11 = 750ps         |
| Bit 2 |                                       | 0   |                                                                                                                  |
| Bit 1 | Reserved                              | X   | Reserved                                                                                                         |
| Bit 0 | Reserved                              | X   | Reserved                                                                                                         |

**Byte 19: Group Skew Control Register**

| Bit   | Name                                 | PWD | Description                                                                                                                                                                                                            |
|-------|--------------------------------------|-----|------------------------------------------------------------------------------------------------------------------------------------------------------------------------------------------------------------------------|
| Bit 7 | Reserved                             | 1   | Reserved                                                                                                                                                                                                               |
| Bit 6 |                                      | 0   |                                                                                                                                                                                                                        |
| Bit 5 |                                      | 0   |                                                                                                                                                                                                                        |
| Bit 4 |                                      | 0   |                                                                                                                                                                                                                        |
| Bit 3 | PCICLK(5:0)<br>Group Skew<br>Control | 1   | These 4 bits can change the CPU to PCI (5:0) skew from 1.4ns - 2.9ns. Default at power up is - 2.5ns. Each binary increment or decrement of Bits (3:0) will increase or decrease the delay of the PCI clocks by 100ps. |
| Bit 2 |                                      | 0   |                                                                                                                                                                                                                        |
| Bit 1 |                                      | 0   |                                                                                                                                                                                                                        |
| Bit 0 |                                      | 0   |                                                                                                                                                                                                                        |

**Byte 20: Group Skew Control Register**

| Bit   | Name                              | PWD | Description                                                                                                                                                                                                      |
|-------|-----------------------------------|-----|------------------------------------------------------------------------------------------------------------------------------------------------------------------------------------------------------------------|
| Bit 7 | PCICLK_F<br>Group Skew<br>Control | 1   | These 4 bits can change the CPU to PCIF skew from 1.4ns - 2.9ns. Default at power up is - 2.5ns. Each binary increment or decrement of Bit (3:0) will increase or decrease the delay of the PCI clocks by 100ps. |
| Bit 6 |                                   | 0   |                                                                                                                                                                                                                  |
| Bit 5 |                                   | 0   |                                                                                                                                                                                                                  |
| Bit 4 |                                   | 0   |                                                                                                                                                                                                                  |
| Bit 3 | Reserved                          | 1   | Reserved                                                                                                                                                                                                         |
| Bit 2 |                                   | 0   |                                                                                                                                                                                                                  |
| Bit 1 |                                   | 0   |                                                                                                                                                                                                                  |
| Bit 0 |                                   | 0   |                                                                                                                                                                                                                  |

**Byte 21: Slew Rate Control Register**

| Bit   | Name              | PWD | Description                                |
|-------|-------------------|-----|--------------------------------------------|
| Bit 7 | CPUCLKT/C_CS      | 0   | CPUCLKT/C_CS clock slew rate control bits. |
| Bit 6 | Slew Rate Control | 1   | 01 = strong; 10 = normal; 00 = weak        |
| Bit 5 | CPUCLKT1/C1       | 0   | CPUCLKT1/C1 clock slew rate control bits.  |
| Bit 4 | Slew Rate Control | 1   | 01 = strong; 10 = normal; 00 = weak        |
| Bit 3 | CPUCLKT2/C2       | 0   | CPUCLKT2/C2 clock slew rate control bits.  |
| Bit 2 | Slew Rate Control | 1   | 01 = strong; 10 = normal; 00 = weak        |
| Bit 1 | AGP_0             | 0   | AGP_0 clock slew rate control bits.        |
| Bit 0 | Slew Rate Control | 1   | 01 = strong; 10 = normal; 00 = weak        |

**Byte 22: Slew Rate Control Register**

| Bit   | Name              | PWD | Description                               |
|-------|-------------------|-----|-------------------------------------------|
| Bit 7 | AGP(2:1)          | 0   | AGP(2:1) clock slew rate control bits.    |
| Bit 6 | Slew Rate Control | 1   | 01 = strong; 10 = normal; 00 = weak       |
| Bit 5 | PCICLK_F          | 0   | PCICLK_F clock slew rate control bits.    |
| Bit 4 | Slew Rate Control | 1   | 01 = strong; 10 = normal; 00 = weak       |
| Bit 3 | PCICLK(7:4)       | 0   | PCICLK(7:4) clock slew rate control bits. |
| Bit 2 | Slew Rate Control | 1   | 01 = strong; 10 = normal; 00 = weak       |
| Bit 1 | PCICLK(3:0)       | 0   | PCICLK(3:0) clock slew rate control bits. |
| Bit 0 | Slew Rate Control | 1   | 01 = strong; 10 = normal; 00 = weak       |

**Byte 23: Slew Rate Control Register**

| Bit   | Name              | PWD | Description                               |
|-------|-------------------|-----|-------------------------------------------|
| Bit 7 | REF               | 0   | REF clock slew rate control bits.         |
| Bit 6 | Slew Rate Control | 1   | 01 = strong; 10 = normal; 00 = weak       |
| Bit 5 | IOAPIC(1:0)       | 0   | IOAPIC(1:0) clock slew rate control bits. |
| Bit 4 | Slew Rate Control | 1   | 01 = strong; 10 = normal; 00 = weak       |
| Bit 3 | 48MHz             | 0   | 48MHz clock slew rate control bits.       |
| Bit 2 | Slew Rate Control | 1   | 01 = strong; 10 = normal; 00 = weak       |
| Bit 1 | 24_48MHz          | 0   | 24_48MHz clock slew rate control bits.    |
| Bit 0 | Slew Rate Control | 1   | 01 = strong; 10 = normal; 00 = weak       |

## Absolute Maximum Ratings

|                               |                                |
|-------------------------------|--------------------------------|
| Supply Voltage                | 5.5 V                          |
| Logic Inputs                  | GND -0.5 V to $V_{DD} + 0.5$ V |
| Ambient Operating Temperature | 0°C to +70°C                   |
| Case Temperature              | 115°C                          |
| Storage Temperature           | -65°C to +150°C                |

Stresses above those listed under *Absolute Maximum Ratings* may cause permanent damage to the device. These ratings are stress specifications only and functional operation of the device at these or any other conditions above those listed in the operational sections of the specifications is not implied. Exposure to absolute maximum rating conditions for extended periods may affect product reliability.

## Electrical Characteristics - Input/Supply/Common Output Parameters

$T_A = 0 - 70^\circ\text{C}$ ; Supply Voltage  $V_{DD} = 3.3$  V +/-5%

| PARAMETER                        | SYMBOL             | CONDITIONS                                             | MIN            | TYP    | MAX            | UNITS         |
|----------------------------------|--------------------|--------------------------------------------------------|----------------|--------|----------------|---------------|
| Input High Voltage               | $V_{IH}$           |                                                        | 2              |        | $V_{DD} + 0.3$ | V             |
| Input Low Voltage                | $V_{IL}$           |                                                        | $V_{SS} - 0.3$ |        | 0.8            | V             |
| Input High Current               | $I_{IH}$           | $V_{IN} = V_{DD}$ ; Inputs with no pull-down resistors |                |        | 5.75           | mA            |
|                                  | $I_{IH}$           | $V_{IN} = V_{DD}$ ; Inputs with pull-down resistors    |                |        | 200            | $\mu\text{A}$ |
| Input Low Current                | $I_{IL1}$          | $V_{IN} = 0$ V; Inputs with no pull-up resistors       | -5.75          |        |                | mA            |
|                                  | $I_{IL2}$          | $V_{IN} = 0$ V; Inputs with pull-up resistors          | -200           |        |                | $\mu\text{A}$ |
| Operating Supply Current         | $I_{DD3.3OP}$      | $C_L = \text{Full load}$ ; Select @ 100 MHz            | 228            | 156    | 360            | mA            |
|                                  | $I_{DD3.3OP}$      | $C_L = \text{Full load}$ ; Select @ 133 MHz            | 220            | 159    | 360            | mA            |
| Powerdown Current                | $I_{DD3.3PD}$      | $I_{REF} = 2.32$ mA                                    |                | 12     | 45             | mA            |
| Input Frequency                  | $F_i$              | $V_{DD} = 3.3$ V                                       |                | 14.318 |                | MHz           |
| Pin Inductance                   | $L_{pin}$          |                                                        |                |        | 7              | nH            |
| Input Capacitance <sup>1</sup>   | $C_{IN}$           | Logic Inputs                                           |                |        | 5              | pF            |
|                                  | $C_{OUT}$          | Output pin capacitance                                 |                |        | 6              | pF            |
|                                  | $C_{INX}$          | X1 & X2 pins                                           | 27             |        | 45             | pF            |
| Clk Stabilization <sup>1,2</sup> | $T_{STAB}$         | From PowerUp or deassertion of PowerDown to 1st clock. |                |        | 2.1            | ms            |
| Delay <sup>1</sup>               | $t_{PZH}, t_{PZL}$ | Output enable delay (all outputs)                      | 1              |        | 12             | ns            |
|                                  | $t_{PHZ}, t_{PLZ}$ | Output disable delay (all outputs)                     | 1              |        | 12             | ns            |

<sup>1</sup>Guaranteed by design, not 100% tested in production.

<sup>2</sup>See timing diagrams for buffered and un-buffered timing requirements.

**Electrical Characteristics - CPUCLKC/T (Current Mode)**
 $T_A = 0 - 70^\circ\text{C}$ ;  $V_{DD} = 3.3\text{V} \pm 5\%$ ;  $C_L = 10\text{-}20\text{ pF}$  (unless otherwise specified)

| PARAMETER                       | SYMBOL                  | CONDITIONS                                                        | MIN  | TYP | MAX  | UNITS    |
|---------------------------------|-------------------------|-------------------------------------------------------------------|------|-----|------|----------|
| Current Source Output Impedance | $Z_o^1$                 | $V_O = V_x$                                                       | 3000 |     |      | $\Omega$ |
| Voltage High                    | VHigh                   | Statistical measurement on single ended signal using oscilloscope | 660  | 810 | 850  | mV       |
| Voltage Low                     | VLow                    |                                                                   | -150 | 20  | 150  |          |
| Max Voltage                     | Vovs                    | Measurement on single ended signal using absolute value.          |      | 850 | 1150 | mV       |
| Min Voltage                     | Vuds                    |                                                                   | -450 | -15 |      |          |
| Crossing Voltage (abs)          | Vcross(abs)             |                                                                   | 250  | 380 | 550  | mV       |
| Crossing Voltage (var)          | d-Vcross                | Variation of crossing over all edges                              |      | 22  | 140  | mV       |
| Rise Time                       | $t_r$                   | $V_{OL} = 0.175\text{V}$ , $V_{OH} = 0.525\text{V}$               | 175  | 290 | 700  | ps       |
| Fall Time                       | $t_f$                   | $V_{OH} = 0.525\text{V}$ , $V_{OL} = 0.175\text{V}$               | 175  | 310 | 700  | ps       |
| Rise Time Variation             | d- $t_r$                |                                                                   |      | 10  | 125  | ps       |
| Fall Time Variation             | d- $t_f$                |                                                                   |      | 10  | 125  | ps       |
| Duty Cycle                      | $d_{t3}$                | Measurement from differential waveform                            | 45   | 51  | 55   | %        |
| Skew                            | $t_{sk3}$               | $V_T = 50\%$                                                      |      | 16  | 100  | ps       |
| Jitter, Cycle to cycle          | $t_{j\text{cyc-cyc}}^1$ | $V_T = 50\%$                                                      |      | 48  | 150  | ps       |

<sup>1</sup>Guaranteed by design, not 100% tested in production.

<sup>2</sup> $I_{OVT}$  can be varied and is selectable thru the MULTSEL pin.

**Electrical Characteristics - CPUCLKODC/T**
 $T_A = 0 - 70^\circ\text{C}$ ;  $V_{DD} = 1.7\text{V} \pm 5\%$ ;  $C_L = 5\text{ pF}$  (unless otherwise stated)

| PARAMETER                                   | SYMBOL                  | CONDITIONS                          | MIN  | TYP  | MAX  | UNITS |
|---------------------------------------------|-------------------------|-------------------------------------|------|------|------|-------|
| Output High Voltage                         | $V_{OH2B}$              | Termination to Vpull-up(external)   | 1    |      | 1.2  | V     |
| Output Low Voltage                          | $V_{OL2B}$              | Termination to Vpull-up(external)   |      |      | 0.4  | V     |
| Output Low Current                          | $I_{OL2B}$              | $V_{OL} = 0.3\text{V}$              | 18   |      |      | mA    |
| Rise Time <sup>1</sup>                      | $t_{r2B}$               | $V_{OL} = 20\%$ , $V_{OH} = 80\%$   |      | 0.38 | 0.9  | ns    |
| Fall Time <sup>1</sup>                      | $t_{f2B}$               | $V_{OH} = 80\%$ , $V_{OL} = 20\%$ , |      | 0.44 | 0.9  | ns    |
| Differential voltage-AC <sup>1</sup>        | $V_{DIF}$               |                                     | 0.4  |      |      | V     |
| Differential voltage-DC <sup>1</sup>        | $V_{DIF}$               |                                     | 0.2  |      |      | V     |
| Differential Crossover Voltage <sup>1</sup> | $V_x$                   |                                     | 550  | 1200 | 1250 | mV    |
| Duty Cycle <sup>1</sup>                     | $d_{t2B}$               | $V_T = 50\%$                        | 45   | 51.5 | 55   | %     |
| Skew <sup>1</sup>                           | $t_{sk2B}$              | $V_T = 50\%$                        |      | 140  | 200  | ps    |
| Jitter Diff, Cycle-to-cycle <sup>1</sup>    | $t_{j\text{cyc-cyc}2B}$ | $V_T = V_X$                         |      | 60   | 250  | ps    |
| Jitter SE, Cycle-to-cycle <sup>1</sup>      | $t_{j\text{cyc-cyc}2B}$ | $V_T = 1.0\text{V}$                 |      | 100  | 250  | ps    |
| Jitter, Absolute <sup>1</sup>               | $t_{j\text{abs}2B}$     | $V_T = 50\%$                        | -250 |      | 250  | ps    |

Notes:

<sup>1</sup> - Guaranteed by design, not 100% tested in production.

### Electrical Characteristics - CPUT/C\_CS

$T_A = 0 - 70^\circ\text{C}$ ;  $V_{DD} = 3.3\text{V} \pm 5\%$ ;  $C_L = 2 \text{ pF}$  (unless otherwise stated)

| PARAMETER                      | SYMBOL                  | CONDITIONS                                       | MIN | TYP  | MAX | UNITS |
|--------------------------------|-------------------------|--------------------------------------------------|-----|------|-----|-------|
| Output High Voltage            | $V_{OH2B}$              | $I_{OH} = -12 \text{ mA}$                        | 2   |      |     | V     |
| Output Low Voltage             | $V_{OL2B}$              | $I_{OL} = 12 \text{ mA}$                         |     |      | 0.4 | V     |
| Output High Current            | $I_{OH2B}$              | $V_{OH} = 1.7 \text{ V}$                         |     |      | -19 | mA    |
| Output Low Current             | $I_{OL2B}$              | $V_{OL} = 0.7 \text{ V}$                         | 19  |      |     | mA    |
| Rise Time                      | $t_{r2B}$               | $V_{OL} = 0.4 \text{ V}, V_{OH} = 2.0 \text{ V}$ |     | 0.91 | 1.6 | ns    |
| Differential Crossover Voltage | $V_x$                   | Note3                                            | 45  |      | 55  | %     |
| Duty Cycle                     | d-t2B                   | $V_T = 1.5 \text{ V}$                            | 45  | 48.7 | 55  | %     |
| Jitter, Cycle to cycle         | $t_{j\text{cyc-cyc}2B}$ | $V_T = 1.5 \text{ V}$                            |     | 62   | 100 | ps    |

<sup>2</sup>  $I_{OVT}$  can be varied and is selectable thru the MULTSEL pin.

### Electrical Characteristics- DDRT/C

$T_A = 0 - 70^\circ\text{C}$ ;  $V_{DD} = 3.3\text{V} \pm 5\%$ ;  $C_L = 30 \text{ pF}$  (unless otherwise specified)

| PARAMETER           | SYMBOL                  | CONDITIONS                | MIN | TYP  | MAX | UNITS |
|---------------------|-------------------------|---------------------------|-----|------|-----|-------|
| Output High Voltage | $V_{OH3}$               | $I_{OH} = -11 \text{ mA}$ | 2.4 |      |     | V     |
| Output Low Voltage  | $V_{OL}^3$              | $I_{OL} = 11 \text{ mA}$  |     |      | 0.4 | V     |
| Output High Current | $I_{OH}^3$              | $V_{OH} = 2.0 \text{ V}$  |     |      | -12 | mA    |
| Output Low Current  | $I_{OL}^3$              | $V_{OL} = 0.8 \text{ V}$  | 12  |      |     |       |
| Rise Time           | $t_{r3}^1$              | 20% to 80%                | 650 | 660  | 950 | ns    |
| Fall Time           | $t_{f3}^1$              | 20% to 80%                | 650 | 660  | 950 | ns    |
| Duty Cycle          | $d_{r3}^1$              | $V_T = 1.5 \text{ V}$     | 45  | 50.3 | 53  | %     |
| Skew                | $t_{sk1}^1$             | $V_T = 1.5 \text{ V}$     |     | 102  | 250 | ps    |
| Jitter              | $t_{j\text{cyc-cyc}}^1$ | $V_T = 1.5 \text{ V}$     |     | 78   | 250 | ps    |

<sup>1</sup> Guaranteed by design, not 100% tested in production.

**Electrical Characteristics- PCICLK**
 $T_A = 0 - 70^\circ\text{C}$ ;  $V_{DD} = 3.3\text{V} \pm 5\%$ ;  $C_L = 30\text{ pF}$  (unless otherwise specified)

| PARAMETER           | SYMBOL          | CONDITIONS                                     | MIN | TYP   | MAX  | UNITS    |
|---------------------|-----------------|------------------------------------------------|-----|-------|------|----------|
| Output Frequency    | $F_O^1$         |                                                |     | 33.33 |      | MHz      |
| Output Impedance    | $R_{DSP1}^1$    | $V_O = V_{DD} \cdot (0.5)$                     | 12  |       | 55   | $\Omega$ |
| Output High Voltage | $V_{OH}^1$      | $I_{OH} = -1\text{ mA}$                        | 2.4 |       |      | V        |
| Output Low Voltage  | $V_{OL}^1$      | $I_{OL} = 1\text{ mA}$                         |     |       | 0.55 | V        |
| Output High Current | $I_{OH}^1$      | $V_{OH@MIN} = 1.0\text{ V}$                    | -33 |       |      | mA       |
|                     |                 | $V_{OH@MAX} = 3.135\text{ V}$                  |     |       | -33  |          |
| Output Low Current  | $I_{OL}^1$      | $V_{OL@MIN} = 1.95\text{ V}$                   | 30  |       |      | mA       |
|                     |                 | $V_{OL@MAX} = 0.4\text{ V}$                    |     |       | 38   |          |
| Rise Time           | $t_{r1}^1$      | $V_{OL} = 0.4\text{ V}, V_{OH} = 2.4\text{ V}$ | 0.5 | 1.8   | 2    | ns       |
| Fall Time           | $t_{f1}^1$      | $V_{OH} = 2.4\text{ V}, V_{OL} = 0.4\text{ V}$ | 0.5 | 1.6   | 2    | ns       |
| Duty Cycle          | $d_{t1}^1$      | $V_T = 1.5\text{ V}$                           | 45  | 52.4  | 55   | %        |
| Skew                | $t_{sk1}^1$     | $V_T = 1.5\text{ V}$                           |     | 239   | 500  | ps       |
| Jitter              | $t_{jvc-cvc}^1$ | $V_T = 1.5\text{ V}$                           |     | 205   | 250  | ps       |

<sup>1</sup>Guaranteed by design, not 100% tested in production.

**Electrical Characteristics- AGP**
 $T_A = 0 - 70^\circ\text{C}$ ;  $V_{DD} = 3.3\text{V} \pm 5\%$ ;  $C_L = 30\text{ pF}$  (unless otherwise specified)

| PARAMETER           | SYMBOL          | CONDITIONS                                     | MIN | TYP   | MAX  | UNITS    |
|---------------------|-----------------|------------------------------------------------|-----|-------|------|----------|
| Output Frequency    | $F_O^1$         |                                                |     | 66.66 |      | MHz      |
| Output Impedance    | $R_{DSP1}^1$    | $V_O = V_{DD} \cdot (0.5)$                     | 12  |       | 55   | $\Omega$ |
| Output High Voltage | $V_{OH}^1$      | $I_{OH} = -1\text{ mA}$                        | 2.4 |       |      | V        |
| Output Low Voltage  | $V_{OL}^1$      | $I_{OL} = 1\text{ mA}$                         |     |       | 0.55 | V        |
| Output High Current | $I_{OH}^1$      | $V_{OH} = 1.0\text{ V}$                        | -33 |       |      | mA       |
|                     |                 | $V_{OH} = 3.135\text{ V}$                      |     |       | -33  |          |
| Output Low Current  | $I_{OL}^1$      | $V_{OL} = 1.95\text{ V}$                       | 30  |       |      | mA       |
|                     |                 | $V_{OL} = 0.4\text{ V}$                        |     |       | 38   |          |
| Rise Time           | $t_{r1}^1$      | $V_{OL} = 0.4\text{ V}, V_{OH} = 2.4\text{ V}$ | 0.5 | 1.5   | 2    | ns       |
| Fall Time           | $t_{f1}^1$      | $V_{OH} = 2.4\text{ V}, V_{OL} = 0.4\text{ V}$ | 0.5 | 1.28  | 2    | ns       |
| Duty Cycle          | $d_{t1}^1$      | $V_T = 1.5\text{ V}$                           | 45  | 52.9  | 55   | %        |
| Skew                | $t_{sk1}^1$     | $V_T = 1.5\text{ V}$                           |     | 40    | 500  | ps       |
| Jitter              | $t_{jvc-cvc}^1$ | $V_T = 1.5\text{ V}$                           |     | 113   | 250  | ps       |

<sup>1</sup>Guaranteed by design, not 100% tested in production.

**Electrical Characteristics - VCH, 48MHz DOT, 48MHz, USB**
 $T_A = 0 - 70^\circ\text{C}$ ;  $V_{DD} = 3.3\text{V} \pm 5\%$ ;  $C_L = 20\text{ pF}$  (unless otherwise specified)

| PARAMETER           | SYMBOL          | CONDITIONS                                     | MIN | TYP  | MAX  | UNITS    |
|---------------------|-----------------|------------------------------------------------|-----|------|------|----------|
| Output Frequency    | $F_{O1}$        |                                                |     | 48   |      | MHz      |
| Output Impedance    | $R_{DSP1}^1$    | $V_O = V_{DD} * (0.5)$                         | 12  | 48   | 55   | $\Omega$ |
| Output High Voltage | $V_{OH}^1$      | $I_{OH} = -1\text{ mA}$                        | 2.4 |      |      | V        |
| Output Low Voltage  | $V_{OL}^1$      | $I_{OL} = 1\text{ mA}$                         |     |      | 0.55 | V        |
| Output High Current | $I_{OH}^1$      | $V_{OH} = 1.0\text{ V}$                        | -29 |      |      | mA       |
|                     |                 | $V_{OH} = 3.135\text{ V}$                      |     |      | -23  |          |
| Output Low Current  | $I_{OL}^1$      | $V_{OL} = 1.95\text{ V}$                       | 29  |      |      | mA       |
|                     |                 | $V_{OL} = 0.4\text{ V}$                        |     |      | 27   |          |
| 48MHz Rise Time     | $t_{r1}^1$      | $V_{OL} = 0.4\text{ V}, V_{OH} = 2.4\text{ V}$ | 0.5 | 1.25 | 2    | ns       |
| 48MHz Fall Time     | $t_{f1}^1$      | $V_{OH} = 2.4\text{ V}, V_{OL} = 0.4\text{ V}$ | 0.5 | 1.27 | 2    | ns       |
| 24MHz Rise Time     | $t_{r1}^1$      | $V_{OL} = 0.4\text{ V}, V_{OH} = 2.4\text{ V}$ | 1   | 1.26 | 2    | ns       |
| 24MHz Fall Time     | $t_{f1}^1$      | $V_{OH} = 2.4\text{ V}, V_{OL} = 0.4\text{ V}$ | 1   | 1.28 | 2    | ns       |
| 48 MHz Duty Cycle   | $d_{t1}^1$      | $V_T = 1.5\text{ V}$                           | 45  | 52.5 | 55   | %        |
| 48MHz Duty Cycle    | $d_{t1}^1$      | $V_T = 1.5\text{ V}$                           | 45  | 51.4 | 55   | %        |
| 48 MHz Jitter       | $t_{jvc-cvc}^1$ | $V_T = 1.5\text{ V}$                           |     | 124  | 350  | ps       |
| 24MHz Jitter        | $t_{jvc-cvc}^1$ | $V_T = 1.5\text{ V}$                           |     | 111  | 350  | ps       |

<sup>1</sup>Guaranteed by design, not 100% tested in production.

\*\* USB is 180 degrees phase different to DOT

**Electrical Characteristics - REF**
 $T_A = 0 - 70^\circ\text{C}$ ;  $V_{DD} = 3.3\text{V} \pm 5\%$ ;  $C_L = 30\text{ pF}$  (unless otherwise specified)

| PARAMETER           | SYMBOL          | CONDITIONS                                     | MIN | TYP   | MAX | UNITS    |
|---------------------|-----------------|------------------------------------------------|-----|-------|-----|----------|
| Output Frequency    | $F_{O1}$        |                                                |     | 14.32 |     | MHz      |
| Output Impedance    | $R_{DSP1}^1$    | $V_O = V_{DD} * (0.5)$                         | 20  |       | 60  | $\Omega$ |
| Output High Voltage | $V_{OH}^1$      | $I_{OH} = -1\text{ mA}$                        | 2.4 |       |     | V        |
| Output Low Voltage  | $V_{OL}^1$      | $I_{OL} = 1\text{ mA}$                         |     |       | 0.4 | V        |
| Output High Current | $I_{OH}^1$      | $V_{OH} = 1.0\text{ V}$                        | -29 |       |     | mA       |
|                     |                 | $V_{OH} = 3.135\text{ V}$                      |     |       | -23 |          |
| Output Low Current  | $I_{OL}^1$      | $V_{OL} = 1.95\text{ V}$                       | 29  |       |     | mA       |
|                     |                 | $V_{OL} = 0.4\text{ V}$                        |     |       | 27  |          |
| Rise Time           | $t_{r1}^1$      | $V_{OL} = 0.4\text{ V}, V_{OH} = 2.4\text{ V}$ | 1   | 1.92  | 4   | ns       |
| Fall Time           | $t_{f1}^1$      | $V_{OH} = 2.4\text{ V}, V_{OL} = 0.4\text{ V}$ | 1   | 1.92  | 4   | ns       |
| Duty Cycle          | $d_{t1}^1$      | $V_T = 1.5\text{ V}$                           | 45  | 54.1  | 55  | %        |
| Jitter              | $t_{jvc-cvc}^1$ | $V_T = 1.5\text{ V}$                           |     | 245   | 500 | ps       |

<sup>1</sup>Guaranteed by design, not 100% tested in production.

## Shared Pin Operation - Input/Output Pins

The I/O pins designated by (input/output) serve as dual signal functions to the device. During initial power-up, they act as input pins. The logic level (voltage) that is present on these pins at this time is read and stored into a 5-bit internal data latch. At the end of Power-On reset, (see AC characteristics for timing values), the device changes the mode of operations for these pins to an output function. In this mode the pins produce the specified buffered clocks to external loads.

To program (load) the internal configuration register for these pins, a resistor is connected to either the VDD (logic 1) power supply or the GND (logic 0) voltage potential. A 10 Kiloohm (10K) resistor is used to provide both the solid CMOS programming voltage needed during the power-up programming period and to provide an insignificant load on the output clock during the subsequent operating period.

Figure 1 shows a means of implementing this function when a switch or 2 pin header is used. With no jumper is installed the pin will be pulled high. With the jumper in place the pin will be pulled low. If programmability is not necessary, than only a single resistor is necessary. The programming resistors should be located close to the series termination resistor to minimize the current loop area. It is more important to locate the series termination resistor close to the driver than the programming resistor.

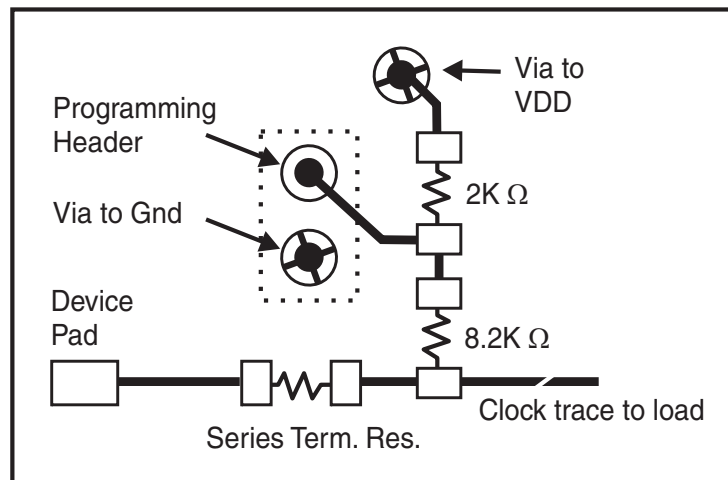

**Fig. 1**

## Power Down Waveforms

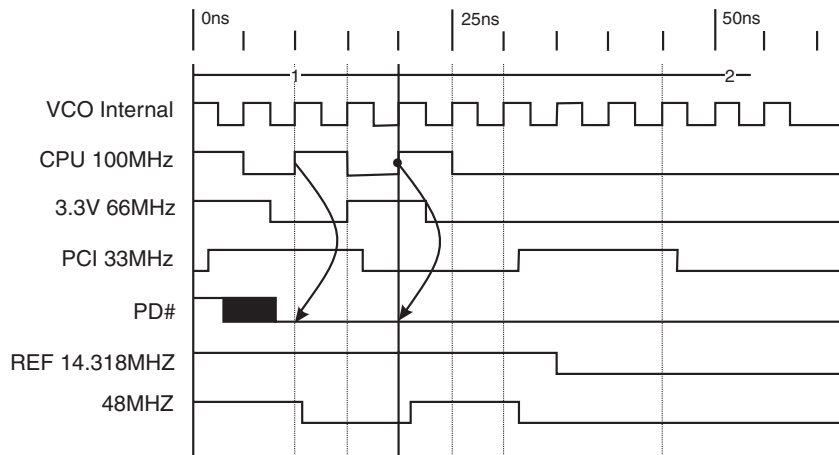

### Note

1. After PD# is sampled active (Low) for 2 consecutive rising edges of CPUCLKs, all the output clocks are driven Low on their next High to Low transition.
2. Power-up latency <3ms.
3. Waveform shown for 100MHz

## Group Offset Waveforms

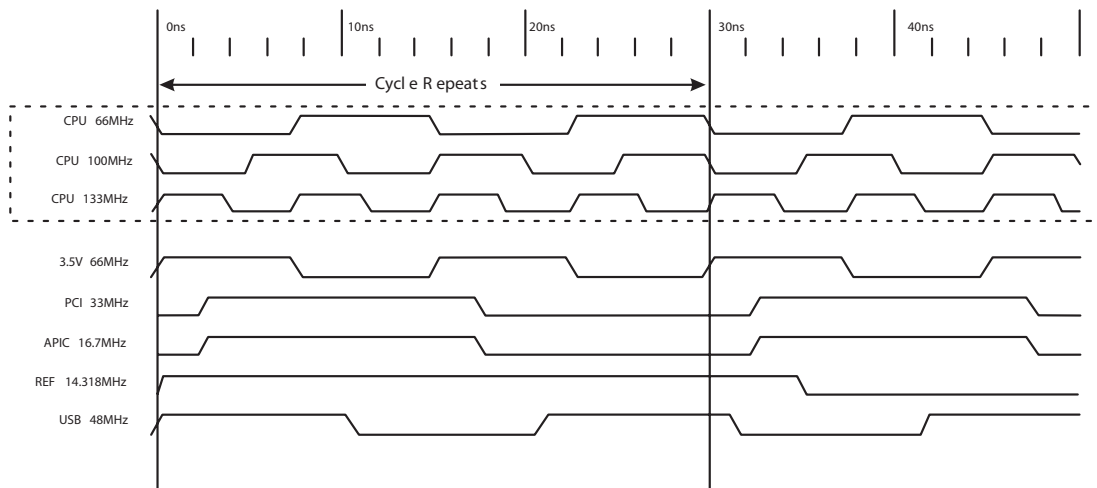

## Group Skews at Common Transition Edges

| GROUP                   | SYMBOL               | CONDITIONS   | MIN | TYP  | MAX | UNITS |
|-------------------------|----------------------|--------------|-----|------|-----|-------|
| CPU408 to CPUCS         | CPU                  | 50% to 1.25V | 0   |      | 250 | ps    |
| CPU Open Drain to CPUCS | CPU                  | 50% to 1.25V | 0   | 75   | 250 |       |
| CPUCS to PCI            | $S_{\text{CPU-PCI}}$ | 1.25 to 1.5V | 0   | 2.8  | 4   | ns    |
| CPU408 to PCI           | $S_{\text{CPU-PCI}}$ | 1.25 to 1.5V | 0   | 3.8  | 4   | ns    |
| AGP to PCI              | $S_{\text{AGP-PCI}}$ | 1.5 to 1.5V  | 1.5 | 2.87 | 3.5 | ns    |

<sup>1</sup>Guaranteed by design, not 100% tested in production.

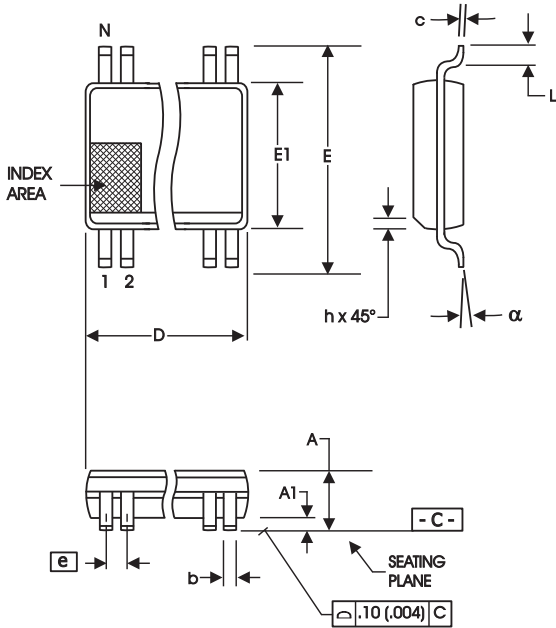

**300 mil SSOP Package**

| SYMBOL | In Millimeters<br>COMMON DIMENSIONS |       | In Inches<br>COMMON DIMENSIONS |       |
|--------|-------------------------------------|-------|--------------------------------|-------|
|        | MIN                                 | MAX   | MIN                            | MAX   |
| A      | 2.41                                | 2.80  | .095                           | .110  |
| A1     | 0.20                                | 0.40  | .008                           | .016  |
| b      | 0.20                                | 0.34  | .008                           | .0135 |
| c      | 0.13                                | 0.25  | .005                           | .010  |
| D      | SEE VARIATIONS                      |       | SEE VARIATIONS                 |       |
| E      | 10.03                               | 10.68 | .395                           | .420  |
| E1     | 7.40                                | 7.60  | .291                           | .299  |
| e      | 0.635 BASIC                         |       | 0.025 BASIC                    |       |
| h      | 0.38                                | 0.64  | .015                           | .025  |
| L      | 0.50                                | 1.02  | .020                           | .040  |
| N      | SEE VARIATIONS                      |       | SEE VARIATIONS                 |       |
| alpha  | 0°                                  | 8°    | 0°                             | 8°    |

**VARIATIONS**

| N  | D mm. |       | D (inch) |      |
|----|-------|-------|----------|------|
|    | MIN   | MAX   | MIN      | MAX  |
| 56 | 18.31 | 18.55 | .720     | .730 |

Reference Doc.: JEDEC Publication 95, MO-118

10-0034

**Ordering Information**

**ICS950910yFLF-T**

Example:

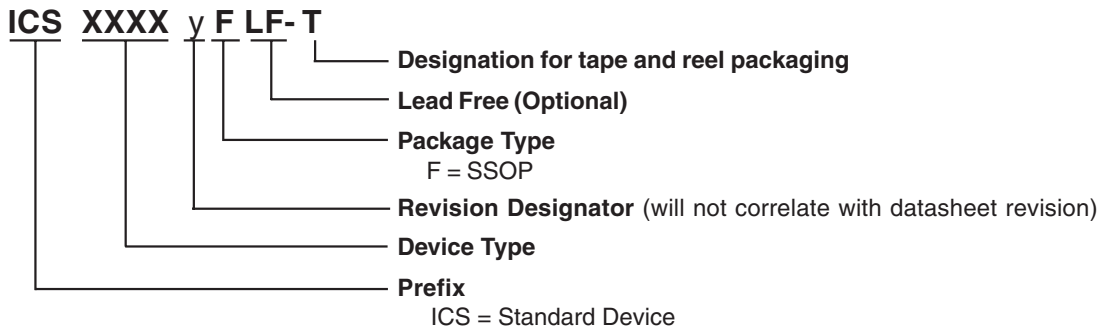



---

---

### Revision History

| Rev. | Issue Date | Description          | Page # |
|------|------------|----------------------|--------|
| B    | 09/21/07   | Updated Pin 18 Typo. | 2      |
|      |            |                      |        |
|      |            |                      |        |
|      |            |                      |        |

## IMPORTANT NOTICE AND DISCLAIMER

RENESAS ELECTRONICS CORPORATION AND ITS SUBSIDIARIES (“RENESAS”) PROVIDES TECHNICAL SPECIFICATIONS AND RELIABILITY DATA (INCLUDING DATASHEETS), DESIGN RESOURCES (INCLUDING REFERENCE DESIGNS), APPLICATION OR OTHER DESIGN ADVICE, WEB TOOLS, SAFETY INFORMATION, AND OTHER RESOURCES “AS IS” AND WITH ALL FAULTS, AND DISCLAIMS ALL WARRANTIES, EXPRESS OR IMPLIED, INCLUDING, WITHOUT LIMITATION, ANY IMPLIED WARRANTIES OF MERCHANTABILITY, FITNESS FOR A PARTICULAR PURPOSE, OR NON-INFRINGEMENT OF THIRD-PARTY INTELLECTUAL PROPERTY RIGHTS.

These resources are intended for developers who are designing with Renesas products. You are solely responsible for (1) selecting the appropriate products for your application, (2) designing, validating, and testing your application, and (3) ensuring your application meets applicable standards, and any other safety, security, or other requirements. These resources are subject to change without notice. Renesas grants you permission to use these resources only to develop an application that uses Renesas products. Other reproduction or use of these resources is strictly prohibited. No license is granted to any other Renesas intellectual property or to any third-party intellectual property. Renesas disclaims responsibility for, and you will fully indemnify Renesas and its representatives against, any claims, damages, costs, losses, or liabilities arising from your use of these resources. Renesas' products are provided only subject to Renesas' Terms and Conditions of Sale or other applicable terms agreed to in writing. No use of any Renesas resources expands or otherwise alters any applicable warranties or warranty disclaimers for these products.

(Disclaimer Rev.1.01)

### Corporate Headquarters

TOYOSU FORESIA, 3-2-24 Toyosu,  
Koto-ku, Tokyo 135-0061, Japan  
[www.renesas.com](http://www.renesas.com)

### Trademarks

Renesas and the Renesas logo are trademarks of Renesas Electronics Corporation. All trademarks and registered trademarks are the property of their respective owners.

### Contact Information

For further information on a product, technology, the most up-to-date version of a document, or your nearest sales office, please visit [www.renesas.com/contact-us/](http://www.renesas.com/contact-us/).