

DA16600MOD

Ultra-Low-Power Wi-Fi + Bluetooth® LE Combo Module

General Description

The DA16600 is a highly integrated ultra-low-power Wi-Fi® + Bluetooth® Low Energy combo module solution. This module includes the DA16200 that has an 802.11b/g/n radio (PHY), a baseband processor, a media access controller (MAC), on-chip memory, and a host networking application processor. The DA16600 also has a DA14531 that has a 2.4 GHz transceiver and an Arm® Cortex-M0+® microcontroller with a RAM of 48 kB and a One-Time Programmable (OTP) memory of 32 kB. The radio transceiver, the baseband processor, and the qualified Bluetooth low energy stack are fully compliant with the Bluetooth Low Energy 5.1 standard.

The DA16600 is a synthesis of breakthrough ultra-low-power technologies, which enables an extremely low power operation in the module. The DA16200 and DA14531 shut down every micro element of the chip that is not in use, which creates a power consumption that is near zero when not actively transmitting or receiving data. Such low power operation can extend the battery life up to a year or more depending on the application. The DA16600 also enables ultra-low-power transmission and reception modes when the SoC needs to be awake to exchange information with other devices. Advanced algorithms enable Sleep mode until the exact moment when wake-up is required to transmit or receive data.

Module Features

- Module variants
 - DA16600MOD-AAC4WA32 (Chip Antenna)
 - DA16600MOD-AAE4WA32 (u.FL Connector)
- Dimensions
 - 14.3 mm × 24.3 mm × 3.0 mm, 51-pins
- Operating temperature range
 - -40 °C to 85 °C
- Regulatory certifications:
 - FCC
 - IC
 - CE
 - TELEC
 - KCC
 - IMDA
 - NCC
 - SRRC
 - WPC

Wi-Fi Features

- Highly integrated ultra-low-power Wi-Fi® system on a chip
- RF performance
 - TX Power: +18 dBm, 1 Mbps DSSS
 - RX Sensitivity: -97.5 dBm, 1 Mbps DSSS
- Full offload: SoC runs full networking OS and TCP/IP stack
- Hardware accelerators
 - General hardware CRC engine
 - Hardware zeroing function for fast booting
 - Pseudo random number generator (PRNG)
- SPI Flash memory
 - 32-Mbit/4 MB
- Complete software stack
 - Comprehensive networking software stack
- Wi-Fi processor
 - IEEE 802.11b/g/n, 1x1, 20 MHz channel bandwidth, 2.4 GHz
 - Wi-Fi security: WPA/WPA2-Enterprise/Personal, WPA2 SI, WPA3 SAE, and OWE
 - Vendor EAP types: EAP-TTLS/MSCHAPv2, PEAPv0/EAP-MSCHAPv2, PEAPv1, EAP-FAST, and EAP-TLS
 - Operating modes: Station and Soft AP
 - WPS-PIN/PBC for easy Wi-Fi provisioning
 - Fast Wi-Fi connections
- Support various interfaces
 - Two UARTs
 - SPI Master/Slave interfaces
 - I2C Master/Slave interfaces
 - I2S for digital audio streaming

- Provide TCP/IP stack in the form of network socket APIs
- CPU core subsystem
 - Arm® Cortex®-M4F core with clock frequency of 30~160 MHz
 - ROM: 256 kB, SRAM: 512 kB, OTP: 8 kB, Retention Memory: 48 kB
- Advanced security
 - Secure booting
 - Secure debugging using JTAG/SWD and UART ports
 - Secure asset storage
- Built-in hardware crypto engines for advanced security
 - TLS/DTLS security protocol functions
 - Crypto engine for key deliberate generic security functions: AES (128,192,256), DES/3DES, SHA1/224/256, RSA, DH, ECC, CHACHA, and TRNG
- 4-channel PWM
- Individually programmable, multiplexed GPIO pins
- JTAG and SWD
- Built-in 2-channel auxiliary ADC for sensor interfaces
 - 12-bit SAR ADC: single-ended two channels
- Supply
 - Operating voltage: 2.1 V to 3.6 V (typical: 3.3 V)
 - 2 Digital I/O supply voltage: 1.8 V/3.3 V
 - Blackout and brownout detector
- Power management unit
 - On-chip RTC
 - Wake-up control of fast booting or full booting with minimal initialization time
 - Support three ultra-low-power Sleep modes.

Bluetooth Features

- Bluetooth
 - Compatible with Bluetooth v5.1, ETSI EN 300 328 and EN 300 440 Class 2 (Europe), FCC CFR47 Part 15 (US) and ARIB STD-T66 (Japan) core
 - Support up to 3 connections
- Processing and memories
 - 16 MHz 32-bit Arm Cortex-M0+ with SWD interface
 - 48 kB RAM
 - 144 kB ROM
 - 32 kB OTP
- Current consumption
 - 2 mA RX at VBAT = 3 V
 - 4 mA TX at VBAT = 3 V and 0 dBm
 - 1.8 μ A at sleep with all RAM retained
- Radio
 - Programmable RF transmit power
 - -93 dBm receiver sensitivity
- Interfaces
 - 2 channel 11-bit ENOB ADC
 - 2 general purpose timers with PWM
 - 5 GPIOs
 - SPI
 - 2x UART, 1-wire UART support
 - I2C
- Power management
 - Operating range (1.8 V - 3.3 V)
 - Inrush current control
- Others
 - Real Time Clock
 - Trimmed 32 MHz crystal.

Contents

General Description.....	1
Module Features	1
Wi-Fi Features	1
Bluetooth Features	2
Contents	3
Figures	4
Tables.....	4
1. Terms and Definitions	5
2. References.....	5
3. Block Diagram.....	6
4. Pinout.....	7
5. Electrical Specifications	11
5.1 Absolute Maximum Ratings.....	11
5.2 Recommended Operating Conditions	11
5.3 Electrical Characteristics	11
5.3.1 DC Parameters, 1.8 V I/O	11
5.3.2 DC Parameters, 3.3 V I/O	12
5.3.3 DC Parameters for RTC Block.....	12
5.4 Radio Characteristics.....	12
5.4.1 Wi-Fi Characteristics	12
5.4.2 Bluetooth® LE Characteristics	13
5.5 Current Consumption.....	13
5.5.1 Wi-Fi Characteristics	13
5.5.2 Bluetooth LE Characteristics.....	14
5.6 Radiation Performance	15
5.7 ESD Ratings	15
5.8 Clock Electrical Characteristics	16
5.8.1 RTC Clock Source	16
5.8.2 Main Clock Source	16
6. Power-On Sequence.....	17
7. Application Schematic	18
8. Mechanical Specifications	19
8.1 Dimension: DA16600MOD-AAC.....	19
8.2 Dimension: DA16600MOD-AAE.....	19
8.3 Marking	20
9. Design Guidelines	21
9.1 PCB Land Pattern.....	21
9.2 4-Layer PCB Example	22
10. Soldering	23
11. Package Information	24
11.1 Tape and Reel	24

11.2 Labeling	26
12. Ordering Information.....	27
Appendix A Regulatory Approval	28
13. Revision History	29

Figures

Figure 1. DA16600MOD block diagram.....	6
Figure 2. DA16600MOD 51 pinout diagram (top view)	7
Figure 3. Measurement plane definition	15
Figure 4. TIS 3D	15
Figure 5. TRP 3D	15
Figure 6. Power-on sequence.....	17
Figure 7. Application schematic.....	18
Figure 8. AAC module dimension	19
Figure 9. AAE module dimension	19
Figure 10. Module shield marking	20
Figure 11. PCB land pattern (top view)	21
Figure 12. PCB land pattern (bottom view)	21
Figure 13. 4-layer PCB example	22
Figure 14. Reflow condition	23
Figure 15. Tape and reel	24
Figure 16. Tape and reel (continued)	25
Figure 17. Component direction	25
Figure 18. Reel labeling.....	26

Tables

Table 1. Pin description	8
Table 2. Absolute maximum ratings	11
Table 3. Recommended operating conditions	11
Table 4. DC parameters, 1.8 V I/O	11
Table 5. DC parameters, 3.3 V I/O	12
Table 6. DC parameters for RTC block, 3.3 V VBAT	12
Table 7. DC parameters for RTC block, 2.1 V VBAT	12
Table 8. Wi-Fi receiver characteristics	12
Table 9. Wi-Fi transmitter characteristics	13
Table 10. Radio 1 MB/s – AC characteristics	13
Table 11. Current consumption in ACTIVE state.....	13
Table 12. Current consumption in low power operation	14
Table 13. DC characteristics.....	14
Table 14. ESD performance	15
Table 15. Power-on sequence timing requirements	17
Table 16. Coexistence connection	18
Table 17. Component value.....	18
Table 18. Typical reflow profile (lead free): J-STD-020C	23
Table 19. Reel specification.....	25
Table 20. Ordering information (production).....	27

1. Terms and Definitions

API	Application Programming Interface
CRC	Cyclic Redundancy Check
DMA	Direct Memory Access
GPIO	General Purpose Input/Output
I2C	Inter-Integrated Circuit
I2S	Inter-IC Sound
IoT	Internet of Things
JTAG	Joint Test Action Group
LDO	Low-dropout Regulator
PLL	Phase-locked Loop
PRNG	Pseudo Random Number Generator
PWM	Pulse Width Modulation
QSPI	Quad-lane SPI
RTC	Real-time Clock
SAR ADC	Successive Approximation Analog-to-Digital Converter
SPI	Serial Peripheral Interface
SWD	Serial Wire Debug
UART	Universal Asynchronous Receivers and Transmitter

2. References

- [1] DA16200 Datasheet, Renesas Electronics.
- [2] DA16200MOD Datasheet, Renesas Electronics.
- [3] DA14531 Datasheet, Renesas Electronics.
- [4] DA14531MOD Datasheet, Renesas Electronics.

Note 1 References are for the latest published version, unless otherwise indicated.

3. Block Diagram

The DA16600 provides a high level of integration for a battery used wireless system, with integrated IEEE 802.11 b/g/n and Bluetooth V5.1. The DA16600 is designed to address the needs of battery used devices that require minimal power consumption and reliable operation.

Figure 1 shows the interconnection of all the physical blocks in the DA16600MOD.

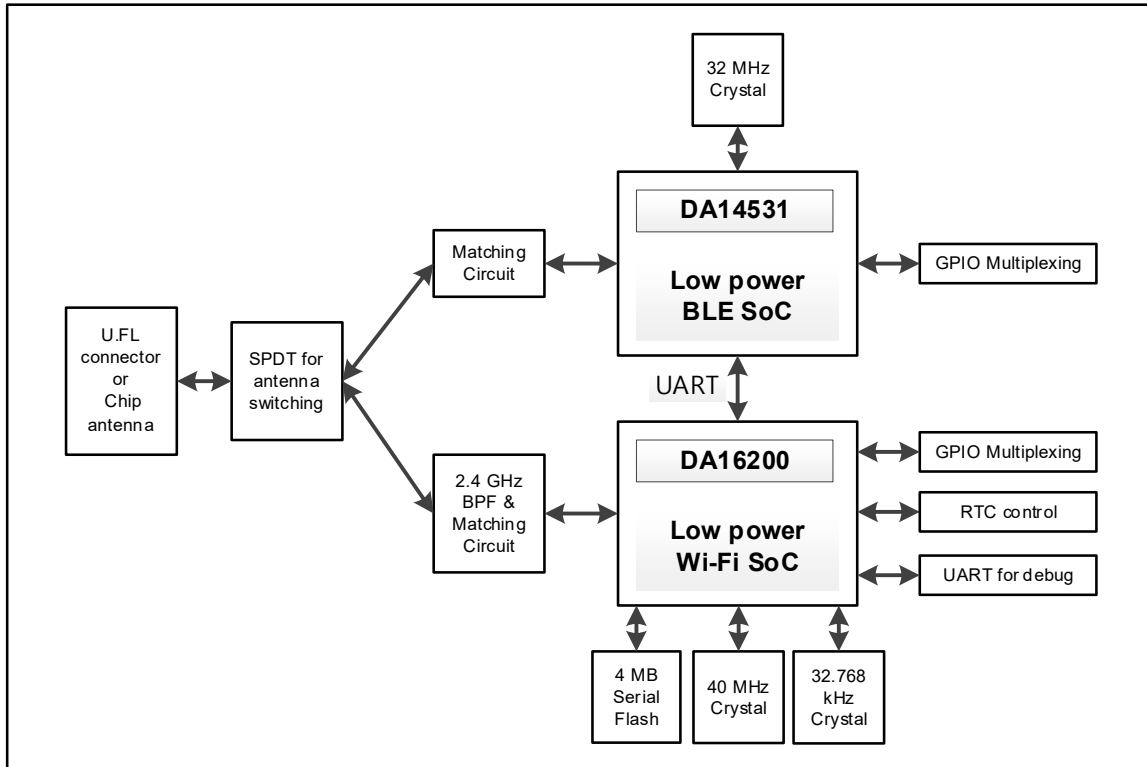

Figure 1. DA16600MOD block diagram

4. Pinout

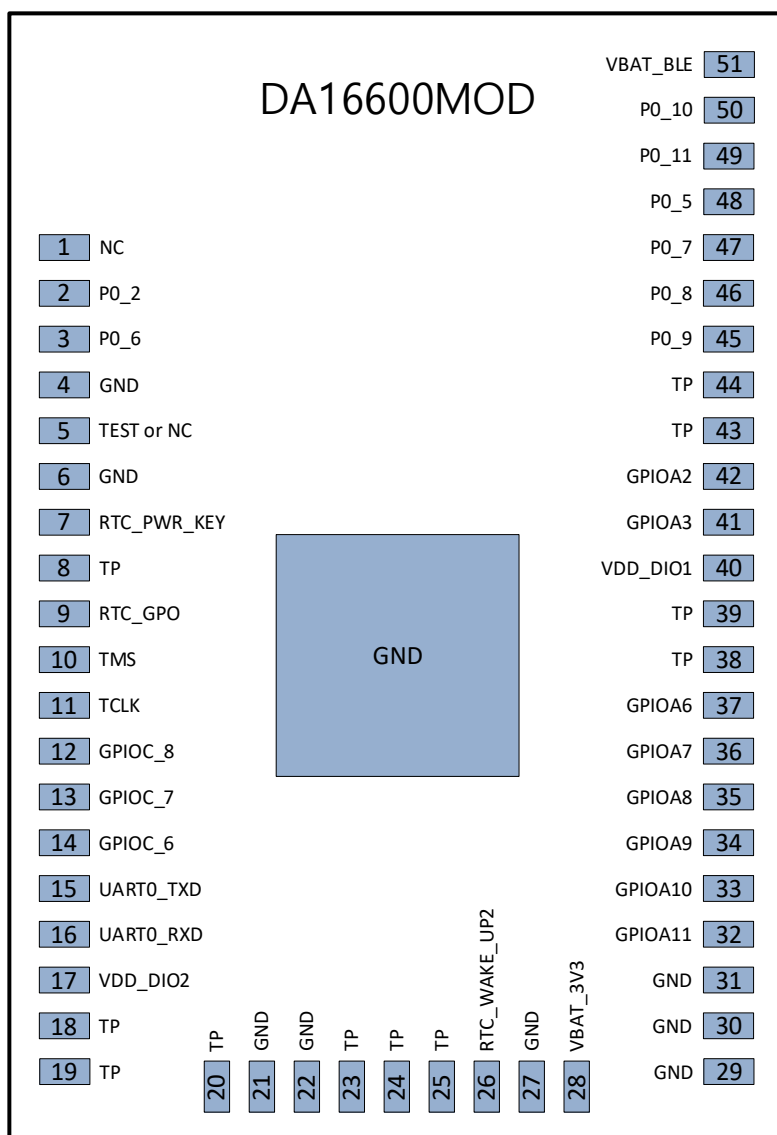

Figure 2. DA16600MOD 51 pinout diagram (top view)

Table 1. Pin description

#Pin	Pin name	Type	Drive (mA)	Reset state	Related device	Description
1	NC	AI			DA14531	Not connected
2	P0_2	DIO			DA14531	General Purpose I/O, JTAG I/F, SWCLK
3	P0_6	DIO			DA14531	Internally connected to RF switch (Note 1).
4	GND	GND			Common	Ground
5	TEST or NC	AI			Common	Chip antenna type: RF_Test u.FL connector type: NC
6	GND	GND			Common	Ground
7	RTC_PWR_KEY	DI			DA16200	RTC block enable signal.
8	TP	DNC			DA16200	RTC block wake-up signal is internally connected (Note 1).
9	RTC_GPO	DO			DA16200	Sensor control signal
10	TMS	DIO	2/4/8/12	I-PU	DA16200	JTAG I/F, SWDIO
11	TCLK	DIO	2/4/8/12	I-PD	DA16200	JTAG I/F, SWCLK, General Purpose I/O
12	GPIOC_8	DIO	2/4/8/12	I-PD	DA16200	General Purpose I/O
13	GPIOC_7	DIO	2/4/8/12	I-PD	DA16200	General Purpose I/O
14	GPIOC_6	DIO	2/4/8/12	I-PD	DA16200	General Purpose I/O
15	UART0_TXD	DO	2/4/8/12	O	DA16200	UART transmit data
16	UART0_RXD	DI	2/4/8/12	I	DA16200	UART receive data
17	VDD_DIO2	VDD			DA16200	Supply power for digital I/O GPIOC6~GPIOC8, TMS/TCLK, TXD/RXD
18	TP	DNC			DA16200	F_IO0 is internally connected to Flash memory.
19	TP	DNC			DA16200	F_CLK is internally connected to Flash memory.
20	TP	DNC			DA16200	F_IO3 is internally connected to Flash memory.
21	GND	GND			Common	Ground
22	GND	GND			Common	Ground
23	TP	DNC			DA16200	F_IO1 is internally connected to Flash memory.
24	TP	DNC			DA16200	F_CSN is internally connected to Flash memory.
25	TP	DNC			DA16200	F_IO2 is internally connected to Flash memory.
26	RTC_WAKE_UP2	DI			DA16200	RTC block wake-up signal
27	GND	GND			Common	Ground

Ultra-Low-Power Wi-Fi + Bluetooth LE Combo Module

#Pin	Pin name	Type	Drive (mA)	Reset state	Related device	Description
28	VBAT_3V3	VDD			DA16200	Supply power for internal DC-DC, DIO_LDO, and Analog IP of DA16200
29	GND	GND			Common	Ground
30	GND	GND			Common	Ground
31	GND	GND			Common	Ground
32	GPIOA11	DIO	2/4/8/12	I-PD	DA16200	General Purpose I/O
33	GPIOA10	DIO	2/4/8/12	I-PD	DA16200	General Purpose I/O
34	GPIOA9	DIO	2/4/8/12	I-PD	DA16200	General Purpose I/O
35	GPIOA8	DIO	2/4/8/12	I-PD	DA16200	General Purpose I/O
36	GPIOA7	DIO	2/4/8/12	I-PD	DA16200	General Purpose I/O
37	GPIOA6	DIO	2/4/8/12	I-PD	DA16200	General Purpose I/O
38	TP	DNC	2/4/8/12	I-PD	Common	GPIOA5 of DA16200 is internally connected to P0_3 of DA14531 (Note 1)
39	TP	DNC	2/4/8/12	I-PD	Common	GPIOA4 of DA16200 is internally connected to P0_4 of DA14531 (Note 1)
40	VDD_DIO1	VDD			DA16200	Supply power for digital I/O GPIOA0~GPIOA11
41	GPIOA3	AI/DIO	2/4/8/12	I-PD	DA16200	Aux ADC input/General Purpose I/O
42	GPIOA2	AI/DIO	2/4/8/12	I-PD	DA16200	Aux ADC input/General Purpose I/O
43	TP	DNC	2/4/8/12	I-PD	Common	GPIOA1 of DA16200 is internally connected to P0_0 of DA14531 (Note 1 and Note 2)
44	TP	DNC	2/4/8/12	I-PD	Common	GPIOA0 of DA16200 is internally connected to P0_1 of DA14531 (Note 1)
45	P0_9	DIO	3.5 / 0.3	I-PD	DA14531	General Purpose I/O, UART Debug TXD
46	P0_8	DIO	3.5 / 0.3	I-PD	DA14531	General Purpose I/O, UART Debug RXD
47	P0_7	DIO	3.5 / 0.3	I-PD	DA14531	General Purpose I/O
48	P0_5	DIO	3.5 / 0.3	I-PD	DA14531	General Purpose I/O
49	P0_11	DIO	3.5 / 0.3	I-PD	DA14531	General Purpose I/O
50	P0_10	DIO	3.5 / 0.3	I-PD	DA14531	General Purpose I/O
51	VBAT_BLE	VDD			DA14531	Supply power for DA14531

Note 1 Pin3, Pin8, Pin 38, Pin 39, Pin 43, and Pin 44 are connected internally so these pins cannot be used as GPIO or wake-up input in application system.

Note 2 P0_0 has a reset function, but it is shared with GTL. Renesas recommends connecting the remaining GPIO as an additional reset function when P0_0 is not available for reset in abnormal situations.

NOTE

See DA16200 datasheet, Ref. [\[1\]](#) and DA14531 datasheet, Ref. [\[3\]](#) for GPIOs functionality.

Ultra-Low-Power Wi-Fi + Bluetooth LE Combo Module

Within the DA16600 module, 4 pins of the DA16200 and the DA14531 are internally connected and therefore cannot be used as GPIOs and are marked as TP (test points) on the DA16600MOD package. The following GPIOs are not available:

- DA16200: GPIOA0, GPIOA1, GPIOA4, GPIOA5
- DA14531: P0_0, P0_1, P0_3, P0_4, P0_6

Because of these internal connections, the SDIO, SDeMMC, and UART1 interfaces of the DA16200 are not available.

To support Bluetooth Coexistence, P06 of the DA14531 (which is internally connected to the RF switch) must be connected to a DA16200 GPIO pin as follows:

- For 1 pin Bluetooth Coexistence, connect P0_6 to GPIOA10
- For 3 pin Bluetooth Coexistence, connect P0_6 to GPIOA9

If GPIOA9 or GPIOA10 is used for Bluetooth Coexistence, it cannot be used as a GPIO.

5. Electrical Specifications

5.1 Absolute Maximum Ratings

Stresses beyond those listed under Absolute Maximum Ratings may cause permanent damage to the device. These are stress ratings only, so functional operation of the device at these or any other conditions beyond those indicated in the operational sections of the specification are not implied. Exposure to Absolute Maximum Rating conditions for extended periods may affect device reliability.

Table 2. Absolute maximum ratings

Parameter	#Pins	Min	Max	Unit
VBAT_3V3	28	-0.2	3.7	V
VDD_DIO1	40	-0.2	3.7	V
VDD_DIO2	17	-0.2	3.7	V
VBAT_BLE	51	-0.1	3.6	V
Storage temperature range		-40	+125	°C

5.2 Recommended Operating Conditions

Table 3. Recommended operating conditions

Parameter	Conditions	Min	Typ	Max	Unit
VBAT_3V3	28	2.1		3.6	V
VDD_DIO1	40	1.62		3.6	V
VDD_DIO2	17	1.62		3.6	V
VBAT_BLE	51	1.8		3.6	V
Operating temperature range (T _A)		-40		+85	°C

5.3 Electrical Characteristics

5.3.1 DC Parameters, 1.8 V I/O

Table 4. DC parameters, 1.8 V I/O

Parameter	Symbol	Conditions	Min	Typ	Max	Unit
Input Low Voltage	V _{IL}	Guaranteed logic low level (Note 1)	VSS		0.3 × DVDD	V
Input High Voltage	V _{IH}	Guaranteed logic high level	0.7 × DVDD		DVDD	V
Output Low Voltage	V _{OL}	DVDD = Min.	VSS		0.2 × DVDD	V
Output High Voltage	V _{OH}	DVDD = Min.	0.8 × DVDD		DVDD	V
Pull-up Resistor	R _{PU}	V _{PAD} = V _{IH} , DIO = Min.			32.4	kΩ
Pull-down Resistor	R _{PD}	V _{PAD} = V _{IL} , DIO = Min.			32.4	

Note 1 DVDD = 1.8 V, VDD_DIO1, VDD_DIO2 logic level.

5.3.2 DC Parameters, 3.3 V I/O

Table 5. DC parameters, 3.3 V I/O

Parameter	Symbol	Conditions	Min	Typ	Max	Unit
Input Low Voltage	V _{IL}	Guaranteed logic low level (Note 1)	VSS		0.8	V
Input High Voltage	V _{IH}	Guaranteed logic high level	2.0		DVDD	V
Output Low Voltage	V _{OL}	DVDD = Min.	VSS		0.4	V
Output High Voltage	V _{OH}	DVDD = Min.	2.4		DVDD	V
Pull-up Resistor	R _{PU}	V _{PAD} = V _{IH} , DIO = Min.			19.4	kΩ
Pull-down Resistor	R _{PD}	V _{PAD} = V _{IL} , DIO = Min.			16.0	

Note 1 DVDD= 3.3 V, VDD_DIO1, VDD_DIO2 logic level.

5.3.3 DC Parameters for RTC Block

There are several control pins in RTC block.

Table 6. DC parameters for RTC block, 3.3 V VBAT

Parameter	Symbol	Conditions	Min	Typ	Max	Unit
Input Low Voltage	V _{IL}	Guaranteed logic low level	VSS		0.6	V
Input High Voltage	V _{IH}	Guaranteed logic high level	2.2		VBAT	V

(RTC block: RTC_PWR_KEY, RTC_WAKE_UP2)

Table 7. DC parameters for RTC block, 2.1 V VBAT

Parameter	Symbol	Conditions	Min	Typ	Max	Unit
Input Low Voltage	V _{IL}	Guaranteed logic low level	VSS		0.3	V
Input High Voltage	V _{IH}	Guaranteed logic high level	1.6		VBAT	V

(RTC block: RTC_PWR_KEY, RTC_WAKE_UP2)

5.4 Radio Characteristics

5.4.1 Wi-Fi Characteristics

Typical values are at T_A = +25 °C, VBAT = 3.3 V, and CH1 (2412 MHz), unless otherwise specified.

Table 8. Wi-Fi receiver characteristics

Parameter	Conditions	Min	Typ	Max	Unit
Sensitivity (8% PER for 11b rates, 10% PER for 11g/11n rates)	1 Mbps DSSS	-98.5	-97.5	-95.5	dBm
	2 Mbps DSSS	-94	-93	-91	
	11 Mbps CCK	-89	-88	-86	
	6 Mbps OFDM	-90	-89	-87	
	9 Mbps OFDM	-90	-89	-87	
	18 Mbps OFDM	-88	-87	-85	
	36 Mbps OFDM	-81	-80	-78	
	54 Mbps OFDM	-75	-74	-72	
	MCS0 (GF)	-90	-89	-87	
	MCS7 (GF)	-72	-71	-69	

Parameter	Conditions	Min	Typ	Max	Unit
Maximum input level (8% PER for 11b rates, 10% PER for 11g/11n rates)	802.11b	-4	0	0	
	802.11g	-10	-4	-3	

Table 9. Wi-Fi transmitter characteristics

Parameter	Conditions	Min	Typ	Max	Unit
Maximum output power measured from IEEE spectral mask and EVM	1 Mbps DSSS	15	18	19	dBm
	2 Mbps DSSS	15	18	19	
	5.5 Mbps CCK	15	18	19	
	11 Mbps CCK	15	18	19	
	6 Mbps OFDM	14	17	18	
	9 Mbps OFDM	14	17	18	
	12 Mbps OFDM	14	17	18	
	18 Mbps OFDM	14	17	18	
	24 Mbps OFDM	13	16	17	
	36 Mbps OFDM	13	16	17	
	48 Mbps OFDM	11.5	14.5	15.5	
	54 Mbps OFDM	10.5	13.5	14.5	
	MCS0 OFDM	14	17	18	
MCS7 OFDM	10.5	13.5	14.5		
Transmit center frequency accuracy		-25	-	+25	ppm

5.4.2 Bluetooth® LE Characteristics

Table 10. Radio 1 MB/s – AC characteristics

Parameter	Description	Conditions	Min	Typ	Max	Unit
P _{SENS_CLEAN}	Sensitivity level	Dirty Transmitter disabled; DC-DC converter disabled; PER = 30.8% (Note 1)		-93		dBm
P _{SENS_EPKT}	Sensitivity level	Extended packet size (255 octets) (Note 1)		-90		dBm

Note 1 Measured according to the Bluetooth® Low Energy Test Specification RF-PHY.TS/5.1.0.

5.5 Current Consumption

5.5.1 Wi-Fi Characteristics

Typical values are at T_A = +25 °C and V_{BAT} = 3.3 V, unless otherwise specified, with CPU clock is 80 MHz.

Table 11. Current consumption in ACTIVE state

Parameter	Conditions		Min	Typ	Max	Unit
ACTIVE	TX	1 Mbps DSSS @ 18.0 dBm	260	280	320	mA
		6 Mbps OFDM @ 17.0 dBm	240	260	300	
		54 Mbps OFDM @ 13.5 dBm	180	200	240	
		MCS7 @ 13.5 dBm	180	200	240	
	RX	No signal (Note 1)	25	29	51	
		1 Mbps DSSS (Note 1)	26.5	30.5	53	

Parameter	Conditions	Min	Typ	Max	Unit
	1 Mbps DSSS	27	37.5	54	
	54 Mbps OFDM	29	38.5	54	
	MCS7	29	38.5	54	

Note 1 Low Power Mode and CPU clock are 30 MHz.

Table 12. Current consumption in low power operation

Parameter	Conditions	Min	Typ	Max	Unit
Low Power Operation	Sleep mode 1		5.2 (Note 1)		μA
	Sleep mode 2		6.8 (Note 1)		
	Sleep mode 3		8.5 (Note 1)		

Note 1 RF switch current consumption is included. VDD of RF switch is connected to VBAT_3V3 for the DA16200 and typical current consumption of RF switch is 5 μA.

5.5.2 Bluetooth LE Characteristics

Table 13. DC characteristics

Parameter	Description	Conditions	Min	Typ	Max	Unit
I _{BAT_ACTIVE}	Battery supply current			0.4		mA
I _{BAT_BLE_ADV_100ms}	Average battery supply current with system in Advertising state (3 channels) every 100 ms and extended sleep with all RAM retained.			80		μA
I _{BAT_BLE_CONN_30ms}	Average battery supply current with system in a connection state with 30 ms connection interval and extended sleep with all RAM retained.			92		μA
I _{BAT_HIBERN}	Battery supply current with system shut down			0.6		μA
I _{BAT_RF_RX}	Battery supply current	Continuous RX		2.3		mA
I _{BAT_RF_TX_+2}	Battery supply current	Continuous TX; Output power at 2 dBm (Note 1)		4.3		mA
I _{BAT_RF_TX_-1}	Battery supply current	Continuous TX; Output power at -1 dBm (Note 2)		3.6		mA
I _{BAT_RF_TX_-4}	Battery supply current	Continuous TX; Output power at -4 dBm		2.8		mA

Note 1 All Bluetooth applications run on the DA16200. Therefore, the DA16200 should be active to handle Bluetooth data (for example, Bluetooth Connection Request coming from a Bluetooth peer), in which case, RX active current of the DA16200 is added to the total current consumption.

Note 2 The actual TX output power is slightly different than the one indicated in the parameter name.

5.6 Radiation Performance

The antenna radiation pattern measurements are carried out in an anechoic chamber. Radiation patterns are presented for three measurement planes: XY-, XZ-, and YZ- planes with horizontal and vertical polarization of the receiving antenna.

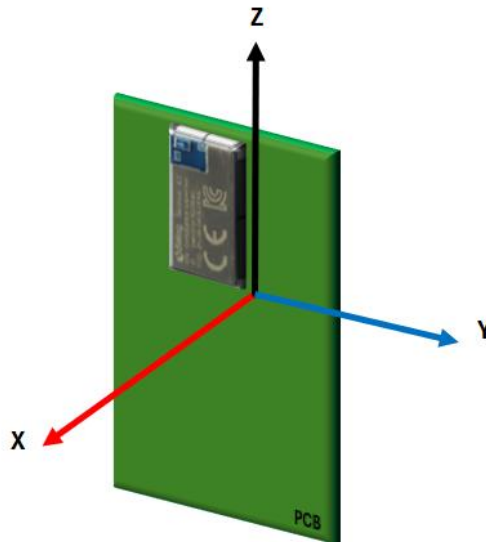

Figure 3. Measurement plane definition

Measurements are carried out for the module installed in the upper left corner on the reference evaluation board.

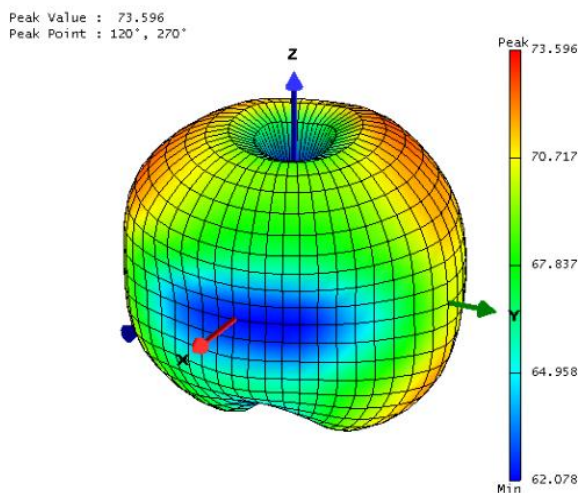

Figure 4. TIS 3D

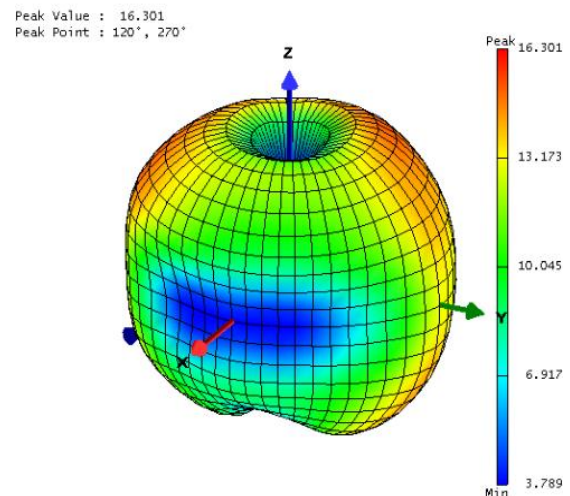

Figure 5. TRP 3D

5.7 ESD Ratings

Table 14. ESD performance

Reliability test	Standards	Test conditions	Result
Human Body Model (HBM)	ANSI/ESDA/JEDEC JS-001-2017	± 2,000 V	Pass
Charge Device Model (CDM)	ANSI/ESDA/JEDEC JS-002-2018	± 500 V	Pass

5.8 Clock Electrical Characteristics

The DA16200MOD has two clock sources, one is the 32.768 kHz clock used by the RTC block and the other is the 40 MHz clock for the internal processor and Wi-Fi system. More specifically, the 40 MHz clock is used as a source clock for the internal PLL while the PLL output is used for the internal processor and Wi-Fi system block.

5.8.1 RTC Clock Source

The 32.768 kHz RTC clock source is needed for the free-running counter in the RTC block. The RTC block of the SoC contains an internal 32.768 kHz RC oscillator as well, which is used as a clock for chip initialization before the external 32.768 kHz crystal reaches the stable time in the initial stage. It is needed to convert it into an external clock for accurate clock counting after the initialization stage. This process is executed through the register setting.

5.8.2 Main Clock Source

The DA16200MOD contains a crystal oscillator for the main clock source which supports the external crystal clock. Basically, the external clock is 40 MHz.

6. Power-On Sequence

The sequence after the initial switching from power-off to power-on of the DA16200 is shown in [Figure 6](#).

The RTC_PWR_KEY is a pin that enables the RTC block of the DA16200. When the RTC_PWR_KEY is enabled after VBAT power is supplied, all the internal regulators are switched on automatically in the sequence pre-defined by the RTC block.

When the RTC_PWR_KEY is switched on, LDOs for both XTAL and digital I/O are switched on shortly and then the DC-DC regulator is switched on according to the pre-defined interval. The enabling intervals can also be modified in the register settings after initial power-up.

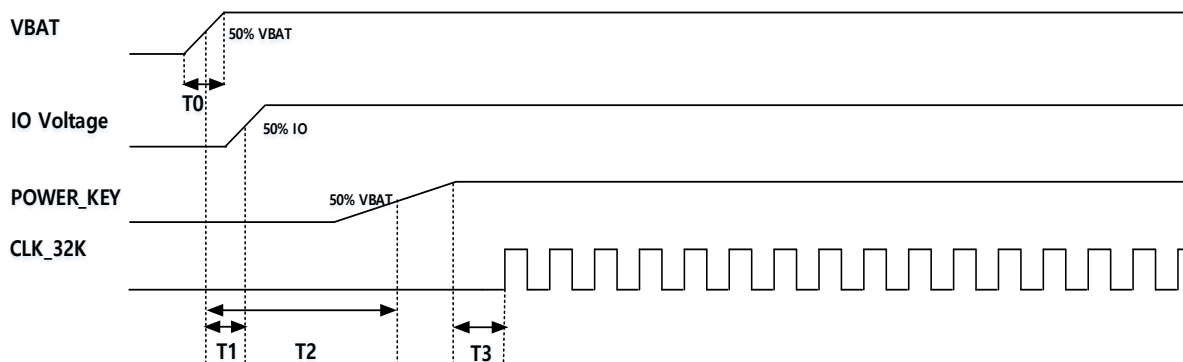

Figure 6. Power-on sequence

Table 15. Power-on sequence timing requirements

Name	Description	Min	Typ	Max	Unit
T0	VBAT power-on time from 10% to 90% of VBAT	-	-	-	ms
T1	I/O voltage and VCC supply	-	0	-	ms
T2	RTC_PWR_KEY turn-on time from 50% VBAT to 50% POWER_KEY * (Note 1)	-	5*T0	-	ms
T3	Internal RC oscillator wake-up time	-	217	-	μs

Note 1 If the T0 = 10 ms to switch on VBAT, the recommended T2 is 50 ms for the safe booting operation. It can be externally controlled by MCU, or it can be implemented using RC filter at the input of the RTC_PWR_KEY. The recommended C is 470 nF or 1 μF (not to exceed 1 μF) and R value is chosen to have T2 delay. For example, R and C values are 82 kΩ and 1μF when T0 = 10 ms.

7. Application Schematic

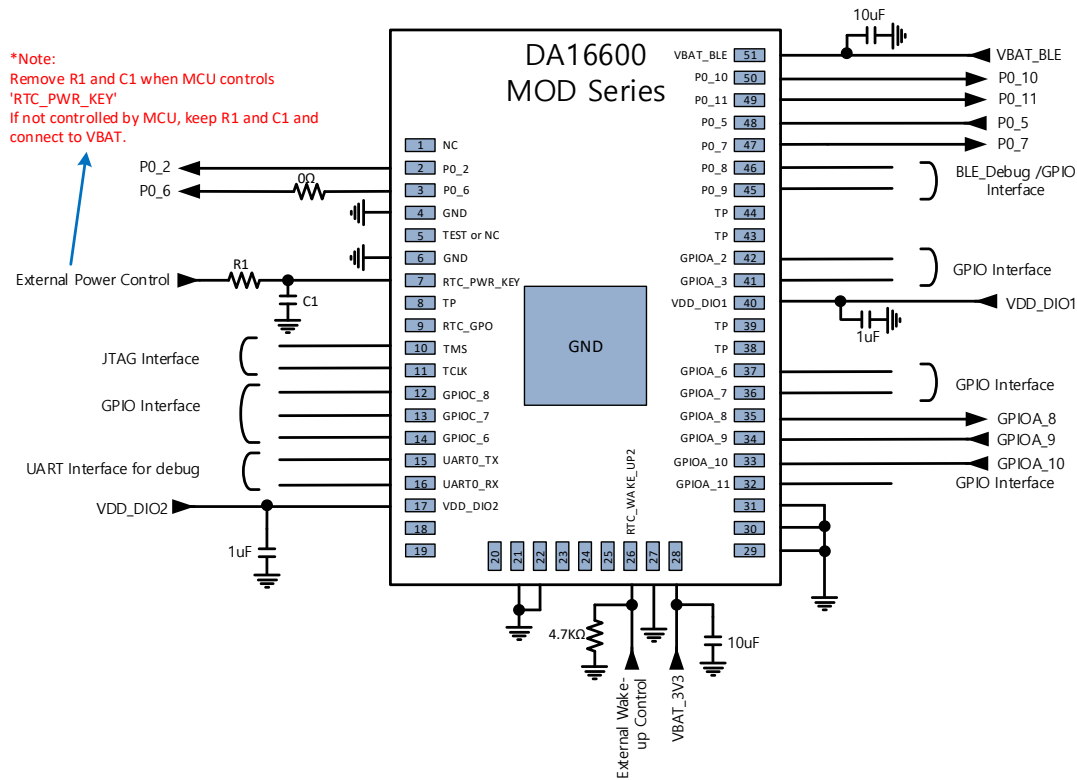

Figure 7. Application schematic

Table 16. Coexistence connection

DA14531 part	DA16200 part	Function
P0_5	GPIOA_8	Wi-Fi_ACT
P0_6	GPIOA_9	BT_ACT
P0_7	GPIOA_10	BT_PRIO

Table 17. Component value

Part reference	Value	Description
R1	470 kΩ	Remove R1 when MCU controls the RTC_PWR_KEY. This value should be chosen by customer application to achieve enough delay time depending on the power-on time of VBAT.
C1	1 μF	Remove C1 when MCU controls the RTC_PWR_KEY. This value should be chosen by customer application to achieve the enough delay time depending on the power-on time of VBAT. Not to exceed 1 μF.

8. Mechanical Specifications

8.1 Dimension: DA16600MOD-AAC

Unit: millimeter (mm)

Tolerance: 14.3 (±0.2) x 24.3 (±0.2) x 3.0 (±0.1)

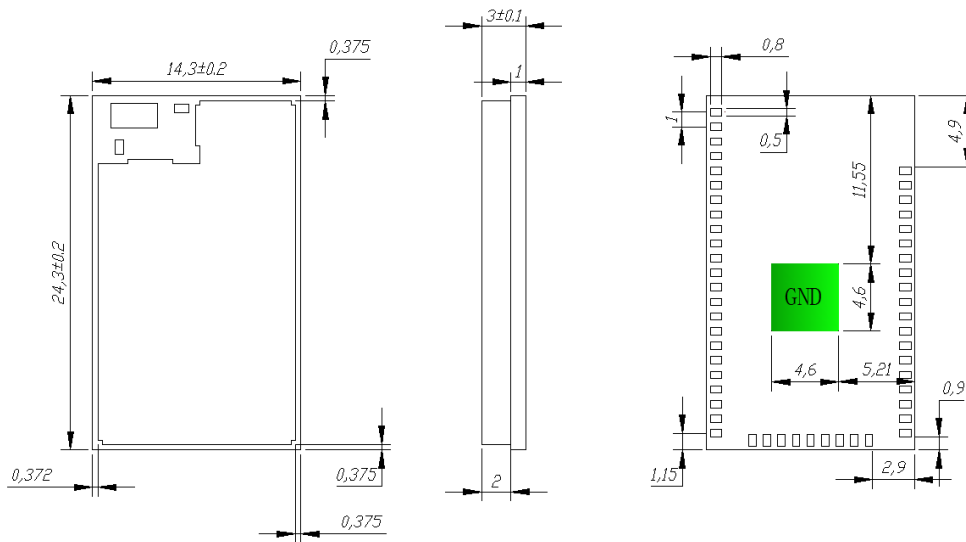

Figure 8. AAC module dimension

8.2 Dimension: DA16600MOD-AAE

Unit: millimeter (mm)

Tolerance: 14.3 (±0.2) x 24.3 (±0.2) x 3.0 (±0.1)

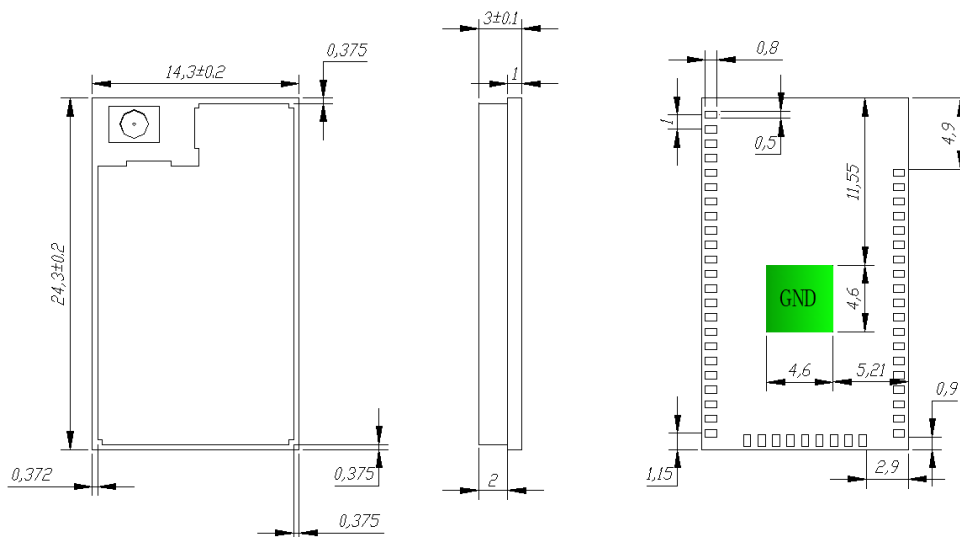

Figure 9. AAE module dimension

8.3 Marking

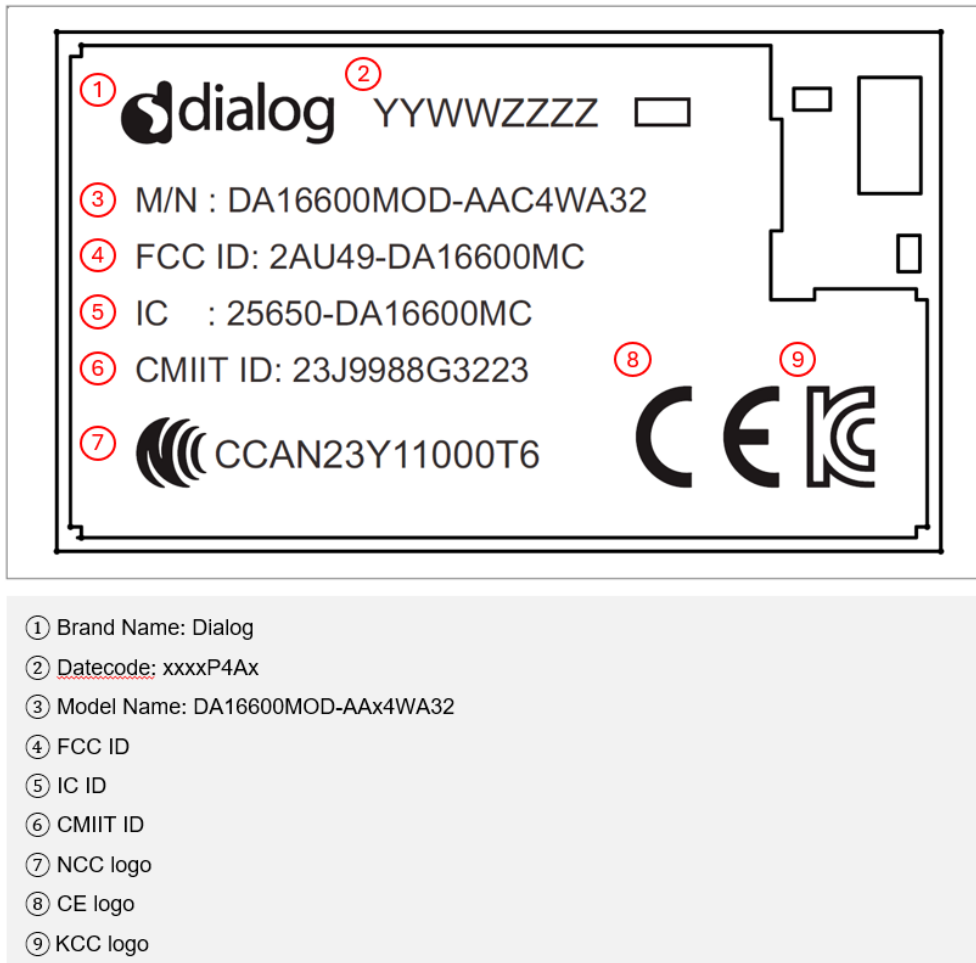

Figure 10. Module shield marking

NOTE

The DA16600MOD-AAC4WA32 only has the NCC logo.

9. Design Guidelines

9.1 PCB Land Pattern

Unit: millimeter (mm)

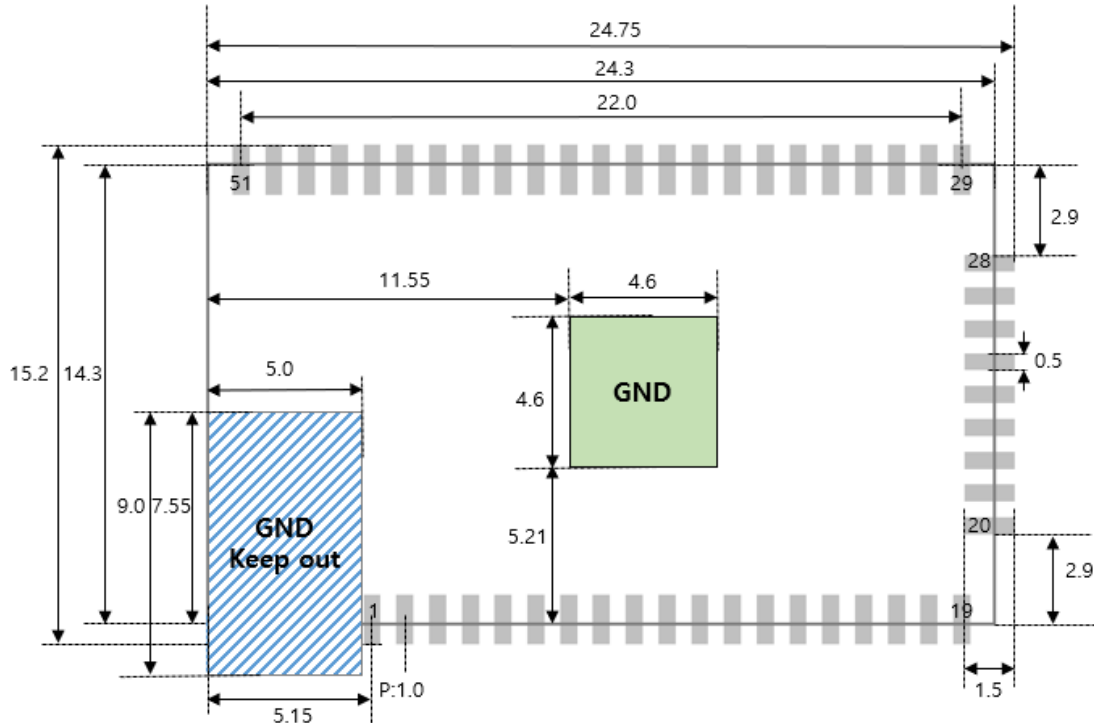

Figure 11. PCB land pattern (top view)

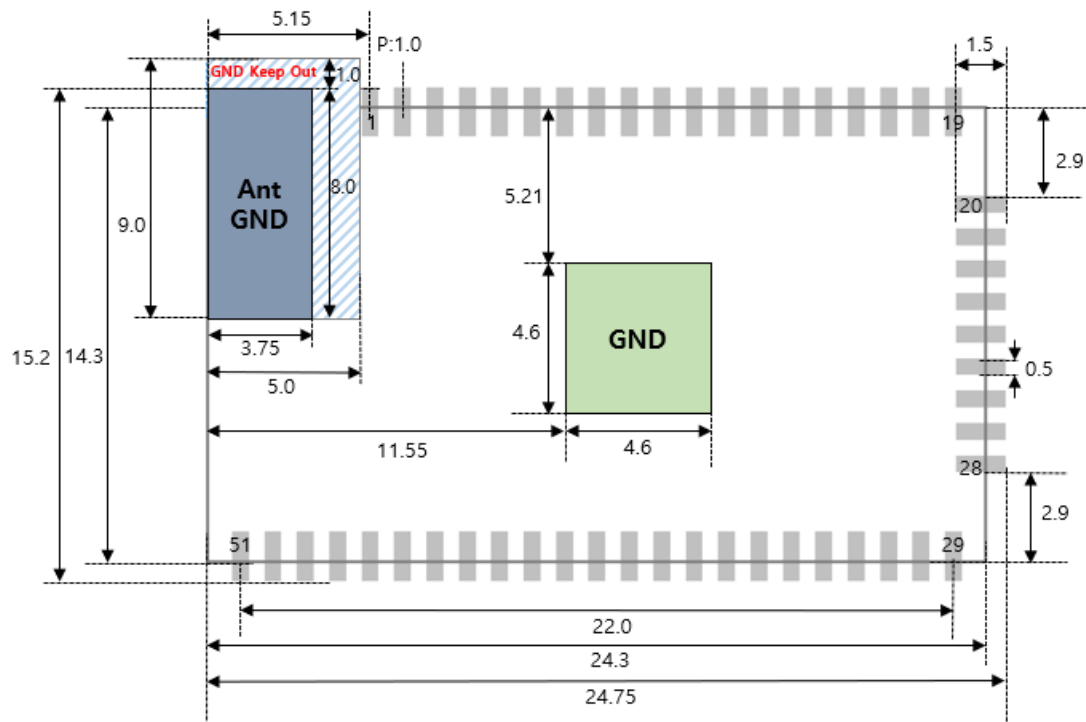

Figure 12. PCB land pattern (bottom view)

9.2 4-Layer PCB Example

The antenna GND is only needed on the bottom of the PCB. The GND must be removed for all layers including the inner layer except the bottom.

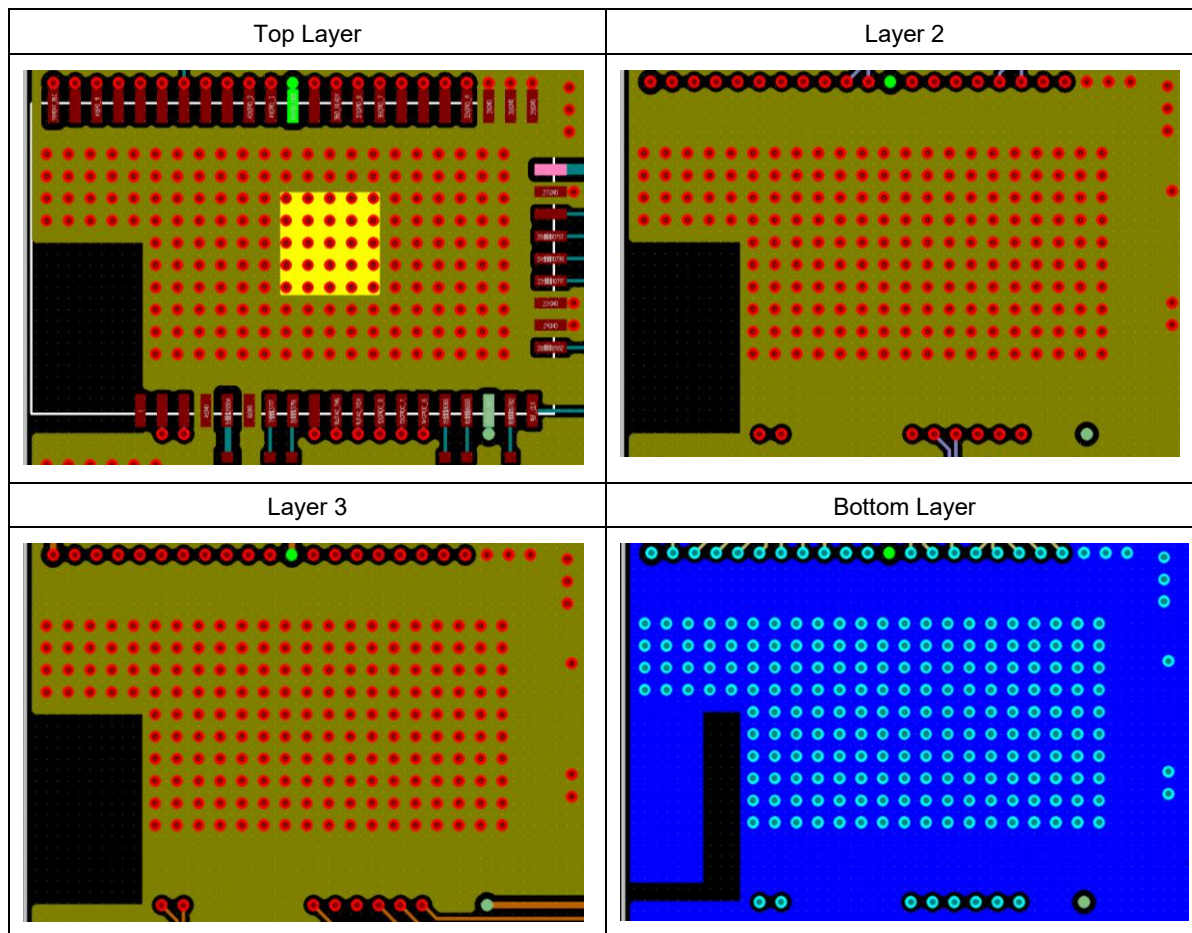

Figure 13. 4-layer PCB example

10. Soldering

The reflow profile depends on the solder paste being used and the recommendations from the paste manufacturer should be followed to determine the proper reflow profile.

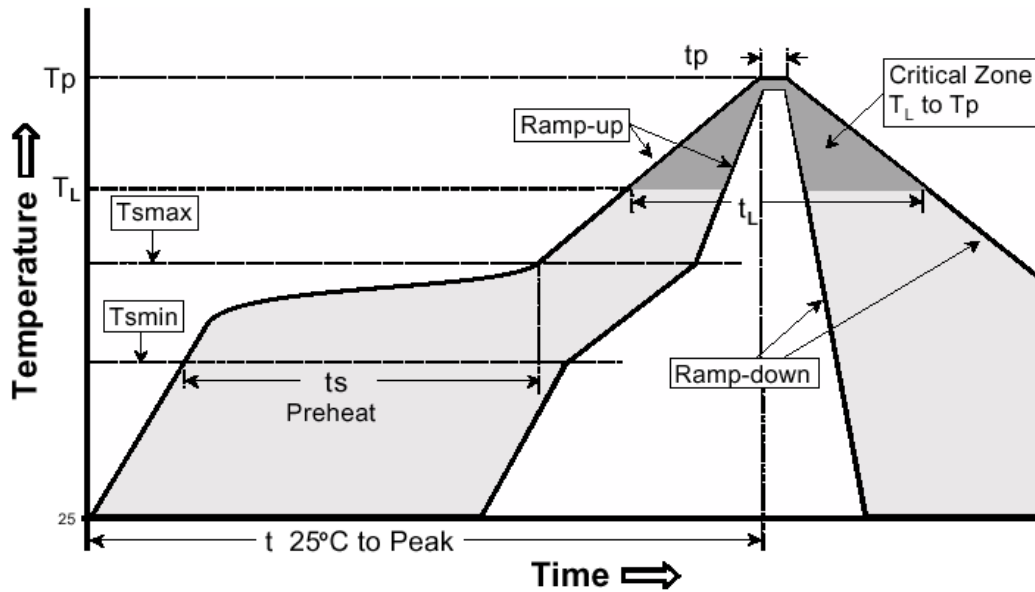

Figure 14. Reflow condition

Table 18. Typical reflow profile (lead free): J-STD-020C

Profile feature	Lead free SMD
Average ramp up rate (T_{smax} to T_p)	3 °C/s Max
Preheat	
<ul style="list-style-type: none"> ▪ Temperature Min (T_{smin}) ▪ Temperature Max (T_{smax}) ▪ Time (T_{smax} to T_{smin}) 	<ul style="list-style-type: none"> ▪ 150 °C ▪ 200 °C ▪ 60 to 180 seconds
Time maintained above	
<ul style="list-style-type: none"> ▪ Temperature (T_L) ▪ Time (t_L) 	<ul style="list-style-type: none"> ▪ 217 °C ▪ 60 to 150 seconds
Peak/Classification temperature (T_p)	260 °C
Time within 5 °C of peak temperature (t_p)	20 to 40 seconds
Ramp down rate	6 °C/s Max
Time from 25 °C to peak temperature	8 minutes Max

11. Package Information

11.1 Tape and Reel

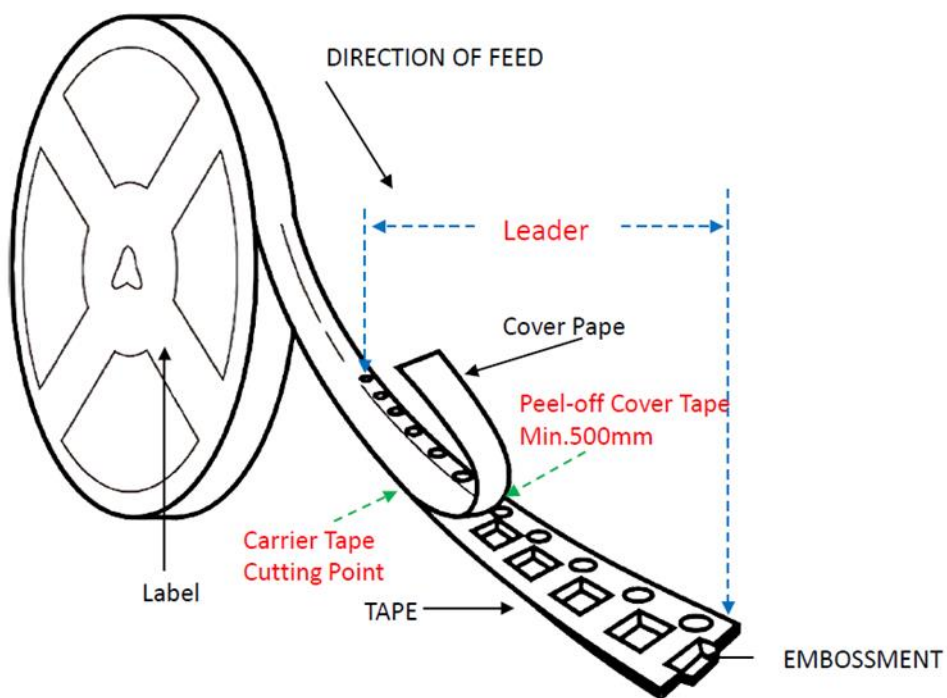

Figure 15. Tape and reel

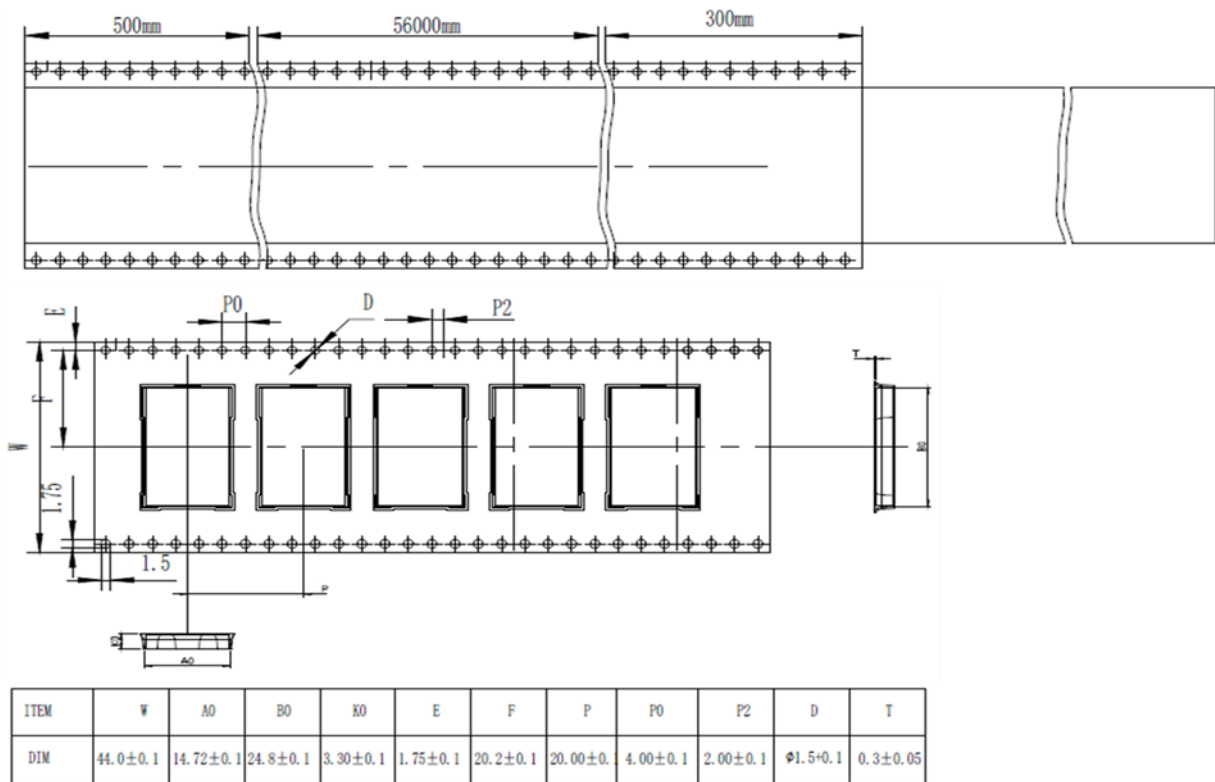

Figure 16. Tape and reel (continued)

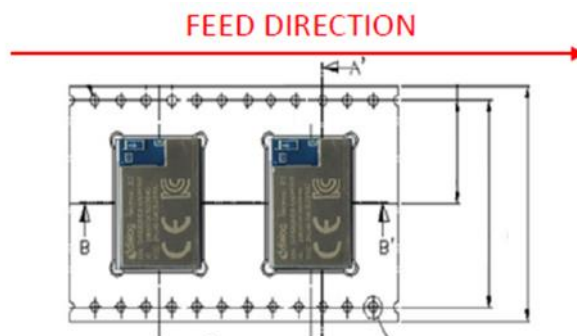

Figure 17. Component direction

The actual reel specifications are presented in [Table 19](#).

Table 19. Reel specification

Item	Description
Diameter	13 inches
Reel tape width	44 mm
Tape material	Antistatic
Qty/Reel	500
Leader	Min. 500 mm
Trailer	Min. 500 mm

11.2 Labeling

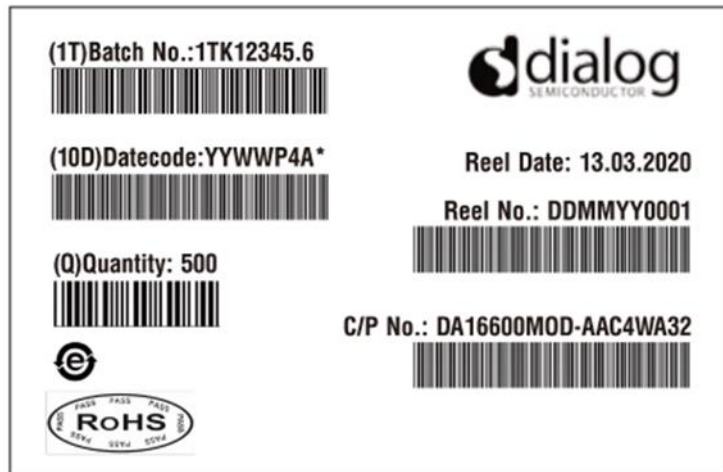

Figure 18. Reel labeling

12. Ordering Information

The order number consists of the part number followed by a suffix that indicates the packing method. For details and availability, visit the Renesas website (<https://www.renesas.com/kr/en/products/wireless-connectivity/wi-fi/low-power-wi-fi>) or contact your local sales representative.

Table 20. Ordering information (production)

Part number	Pins	Size (mm)	Shipment form	Pack quantity
DA16600MOD-AAC4WA32	51	14.3 x 24.3 x 3.0	Reel	500
DA16600MOD-AAE4WA32	51	14.3 x 24.3 x 3.0	Reel	500

Part Number Legend:

DA16600MOD-AAC4WA32

- AA: Module revision number
- C: Select module type
 - [C] Chip antenna, [E] u.FL connector
- 4: Flash memory
 - [4] 4 MB, [2] 2 MB
- W: Voltage range
 - [W] 3.3 V, [L] 1.8 V
- A3: Package No.
- 2: T&R packing

Appendix A Regulatory Approval

The DA16600MOD-AAC and DA16600MOD-AAE modules have received regulatory approval for the following countries:

- **FCC/United States**
 - DA16600MOD-AAC4WA32 FCC ID: 2AU49-DA16600MC
 - DA16600MOD-AAE4WA32 FCC ID: 2AU49-DA16600ME
- **IC/Canada**
 - DA16600MOD-AAC4WA32 IC ID: 25650-DA16600MC
 - DA16600MOD-AAE4WA32 IC ID: 25650-DA16600ME
- **KCC/Korea**
 - DA16600MOD-AAC4WA32 KCC ID: R-C-fci-DA16600AAC
 - DA16600MOD-AAE4WA32 KCC ID: R-C-fci-DA16600AAE
- **TELEC/Japan**
 - DA16600MOD-AAC4WA32 TELEC ID:
 R 210-155426
 - DA16600MOD-AAE4WA32 TELEC ID:
 R 210-216668
- **CE/Europe**
 - DA16600MOD-AAC4WA32 CE ID: LCS200907037AE
 - DA16600MOD-AAE4WA32 CE ID: LCS200907033AE
- **SRRC/China**
 - DA16600MOD-AAC4WA32 CMIIT ID: 23J9988G3223
 - DA16600MOD-AAE4WA32 CMIIT ID: 23J9988GT642(M)
- **IMDA/Singapore**
 - DA16600MOD-AAC4WA32 IMDA ID: N4512-23
- **WPC/India**
 - DA16600MOD-AAC4WA32 WPC ID: ETA-SD-20240909185
 - DA16600MOD-AAE4WA32 WPC ID: ETA-SD-20240909181
- **NCC/Taiwan**
 - DA16600MOD-AAC4WA32

「取得審驗證明之低功率射頻器材，非經核准，公司、商號或使用者均不得擅自變更頻率、加大功率或變更原設計之特性及功能。低功率射頻器材之使用不得影響飛航安全及干擾合法通信；經發現有干擾現象時，應立即停用，並改善至無干擾時方得繼續使用。前述合法通信，指依電信管理法規定作業之無線電通信。低功率射頻器材須忍受合法通信或工業、科學及醫療用電波輻射性電機設備之干擾。」

- 此模組於取得認證後將依規定於模組本體標示審驗合格標籤，並要求平台廠商於平台上標示本產品內含發射器模組

 CCAN23Y11000T6

NOTE

The NCC ID must be clearly displayed on the exterior of the finished product or mounted board.

13. Revision History

Revision	Date	Description
3.7	Oct 31, 2025	<ul style="list-style-type: none"> ▪ Updated Table 3 ▪ Updated Figure 3
3.6	Feb 17, 2025	<ul style="list-style-type: none"> ▪ Changed unit mA to μA in Table 12
3.5	Oct 31, 2024	<ul style="list-style-type: none"> ▪ Updated Appendix A ▪ Added note to pin description table ▪ Added measurement plane definition ▪ Updated Section 11.1
3.4	Apr 12, 2024	<ul style="list-style-type: none"> ▪ Added regulatory certifications in Appendix A: NCC and SRRC ▪ Updated Section 8.3
3.3	Oct 05, 2023	<ul style="list-style-type: none"> ▪ Removed redundant sections ▪ Added Appendix A ▪ Added Tape and Reel Information
3.2	Jan 04, 2023	<ul style="list-style-type: none"> ▪ Section 3.1 updated coexistence description ▪ Updated Table 3 to add storage temperature range and adjusted min max voltages
3.1	June 14, 2022	<ul style="list-style-type: none"> ▪ Updated logo, disclaimer, and copyright ▪ Section 3.1 updated Pin Multiplexing Table 2 ▪ Section 6 updated application Schematic Figure 6 ▪ Updated Pin description Table 1
3.0	Feb 23, 2021	Official release
1.4	Oct 26, 2020	Modified application schematic
1.3	July 15, 2020	Modified application schematic
1.2	May 22, 2020	Added ESD performance, Table 14
1.1	Apr 29, 2020	Preliminary datasheet

RoHS Compliance

Renesas Electronics' suppliers certify that its products are in compliance with the requirements of Directive 2011/65/EU of the European Parliament on the restriction of the use of certain hazardous substances in electrical and electronic equipment. RoHS certificates from our suppliers are available on request.

IMPORTANT NOTICE AND DISCLAIMER

RENESAS ELECTRONICS CORPORATION AND ITS SUBSIDIARIES (“RENESAS”) PROVIDES TECHNICAL SPECIFICATIONS AND RELIABILITY DATA (INCLUDING DATASHEETS), DESIGN RESOURCES (INCLUDING REFERENCE DESIGNS), APPLICATION OR OTHER DESIGN ADVICE, WEB TOOLS, SAFETY INFORMATION, AND OTHER RESOURCES “AS IS” AND WITH ALL FAULTS, AND DISCLAIMS ALL WARRANTIES, EXPRESS OR IMPLIED, INCLUDING, WITHOUT LIMITATION, ANY IMPLIED WARRANTIES OF MERCHANTABILITY, FITNESS FOR A PARTICULAR PURPOSE, OR NON-INFRINGEMENT OF THIRD-PARTY INTELLECTUAL PROPERTY RIGHTS.

These resources are intended for developers who are designing with Renesas products. You are solely responsible for (1) selecting the appropriate products for your application, (2) designing, validating, and testing your application, and (3) ensuring your application meets applicable standards, and any other safety, security, or other requirements. These resources are subject to change without notice. Renesas grants you permission to use these resources only to develop an application that uses Renesas products. Other reproduction or use of these resources is strictly prohibited. No license is granted to any other Renesas intellectual property or to any third-party intellectual property. Renesas disclaims responsibility for, and you will fully indemnify Renesas and its representatives against, any claims, damages, costs, losses, or liabilities arising from your use of these resources. Renesas' products are provided only subject to Renesas' Terms and Conditions of Sale or other applicable terms agreed to in writing. No use of any Renesas resources expands or otherwise alters any applicable warranties or warranty disclaimers for these products.

(Disclaimer Rev.1.01 Jan 2024)

Corporate Headquarters

TOYOSU FORESIA, 3-2-24 Toyosu
Koto-ku, Tokyo 135-0061, Japan

www.renesas.com

Trademarks

Renesas and the Renesas logo are trademarks of Renesas Electronics Corporation. All trademarks and registered trademarks are the property of their respective owners.

Contact Information

For further information on a product, technology, the most up-to-date version of a document, or your nearest sales office, please visit www.renesas.com/contact-us

© 2025 Renesas Electronics Corporation. All rights reserved.