

V850E2/FJ4

32

32-bit Single-Chip Microcontroller

μPD70F3551

μPD70F3552

μPD70F3553

μPD70F3554

μPD70F4003

μPD70F4004

μPD70F4005

μPD70F4006

Notice

1. All information included in this document is current as of the date this document is issued. Such information, however, is subject to change without any prior notice. Before purchasing or using any Renesas Electronics products listed herein, please confirm the latest product information with a Renesas Electronics sales office. Also, please pay regular and careful attention to additional and different information to be disclosed by Renesas Electronics such as that disclosed through our website.
2. Renesas Electronics does not assume any liability for infringement of patents, copyrights, or other intellectual property rights of third parties by or arising from the use of Renesas Electronics products or technical information described in this document. No license, express, implied or otherwise, is granted hereby under any patents, copyrights or other intellectual property rights of Renesas Electronics or others.
3. You should not alter, modify, copy, or otherwise misappropriate any Renesas Electronics product, whether in whole or in part.
4. Descriptions of circuits, software and other related information in this document are provided only to illustrate the operation of semiconductor products and application examples. You are fully responsible for the incorporation of these circuits, software, and information in the design of your equipment. Renesas Electronics assumes no responsibility for any losses incurred by you or third parties arising from the use of these circuits, software, or information.
5. When exporting the products or technology described in this document, you should comply with the applicable export control laws and regulations and follow the procedures required by such laws and regulations. You should not use Renesas Electronics products or the technology described in this document for any purpose relating to military applications or use by the military, including but not limited to the development of weapons of mass destruction. Renesas Electronics products and technology may not be used for or incorporated into any products or systems whose manufacture, use, or sale is prohibited under any applicable domestic or foreign laws or regulations.
6. Renesas Electronics has used reasonable care in preparing the information included in this document, but Renesas Electronics does not warrant that such information is error free. Renesas Electronics assumes no liability whatsoever for any damages incurred by you resulting from errors in or omissions from the information included herein.
7. Renesas Electronics products are classified according to the following three quality grades: "Standard", "High Quality", and "Specific". The recommended applications for each Renesas Electronics product depends on the product's quality grade, as indicated below. You must check the quality grade of each Renesas Electronics product before using it in a particular application. You may not use any Renesas Electronics product for any application categorized as "Specific" without the prior written consent of Renesas Electronics. Further, you may not use any Renesas Electronics product for any application for which it is not intended without the prior written consent of Renesas Electronics. Renesas Electronics shall not be in any way liable for any damages or losses incurred by you or third parties arising from the use of any Renesas Electronics product for an application categorized as "Specific" or for which the product is not intended where you have failed to obtain the prior written consent of Renesas Electronics.

The quality grade of each Renesas Electronics product is “Standard” unless otherwise expressly specified in a Renesas Electronics data sheets or data books, etc.

- “Standard”:
- Computers; office equipment; communications equipment; test and measurement equipment; audio and visual equipment; home electronic appliances; machine tools; personal electronic equipment; and industrial robots.
- “High Quality”:
- Transportation equipment (automobiles, trains, ships, etc.); traffic control systems; anti-disaster systems; anti-crime systems; safety equipment; and medical equipment not specifically designed for life support.
- “Specific”:
- Aircraft; aerospace equipment; submersible repeaters; nuclear reactor control systems; medical equipment or systems for life support (e.g. artificial life support devices or systems), surgical implantations, or healthcare intervention (e.g. excision, etc.), and any other applications or purposes that pose a direct threat to human life.

8. You should use the Renesas Electronics products described in this document within the range specified by Renesas Electronics, especially with respect to the maximum rating, operating supply voltage range, movement power voltage range, heat radiation characteristics, installation and other product characteristics. Renesas Electronics shall have no liability for malfunctions or damages arising out of the use of Renesas Electronics products beyond such specified ranges.
9. Although Renesas Electronics endeavors to improve the quality and reliability of its products, semiconductor products have specific characteristics such as the occurrence of failure at a certain rate and malfunctions under certain use conditions. Further, Renesas Electronics products are not subject to radiation resistance design. Please be sure to implement safety measures to guard them against the possibility of physical injury, and injury or damage caused by fire in the event of the failure of a Renesas Electronics product, such as safety design for hardware and software including but not limited to redundancy, fire control and malfunction prevention, appropriate treatment for aging degradation or any other appropriate measures. Because the evaluation of microcomputer software alone is very difficult, please evaluate the safety of the final products or system manufactured by you.
10. Please contact a Renesas Electronics sales office for details as to environmental matters such as the environmental compatibility of each Renesas Electronics product. Please use Renesas Electronics products in compliance with all applicable laws and regulations that regulate the inclusion or use of controlled substances, including without limitation, the EU RoHS Directive. Renesas Electronics assumes no liability for damages or losses occurring as a result of your noncompliance with applicable laws and regulations.

-
11. This document may not be reproduced or duplicated, in any form, in whole or in part, without prior written consent of Renesas Electronics.
 12. Please contact a Renesas Electronics sales office if you have any questions regarding the information contained in this document or Renesas Electronics products, or if you have any other inquiries.

- Notes**
1. "Renesas Electronics" as used in this document means Renesas Electronics Corporation and also includes its majority-owned subsidiaries.
 2. "Renesas Electronics product(s)" means any product developed or manufactured by or for Renesas Electronics.

Regional Information

Some information contained in this document may vary from country to country. Before using any Renesas Electronics product in your application, please contact the Renesas Electronics office in your country to obtain a list of authorized representatives and distributors. They will verify:

- Device availability
- Ordering information
- Product release schedule
- Availability of related technical literature
- Development environment specifications (for example, specifications for third-party tools and components, host computers, power plugs, AC supply voltages, and so forth)
- Network requirements

In addition, trademarks, registered trademarks, export restrictions, and other legal issues may also vary from country to country.

Visit

<http://www.renesas.com>

to get in contact with your regional representatives and distributors.

Notes for CMOS Devices

(1) Precaution against ESD for semiconductors

Strong electric field, when exposed to a MOS device, can cause destruction of the gate oxide and ultimately degrade the device operation. Steps must be taken to stop generation of static electricity as much as possible, and quickly dissipate it once, when it has occurred. Environmental control must be adequate. When it is dry, humidifier should be used. It is recommended to avoid using insulators that easily build static electricity. Semiconductor devices must be stored and transported in an anti-static container, static shielding bag or conductive material. All test and measurement tools including work bench and floor should be grounded. The operator should be grounded using wrist strap. Semiconductor devices must not be touched with bare hands. Similar precautions need to be taken for PW boards with semiconductor devices on it.

(2) Handling of unused input pins for CMOS

No connection for CMOS device inputs can be cause of malfunction. If no connection is provided to the input pins, it is possible that an internal input level may be generated due to noise, etc., hence causing malfunction. CMOS devices behave differently than Bipolar or NMOS devices. Input levels of CMOS devices must be fixed high or low by using a pull-up or pull-down circuitry. Each unused pin should be connected to VDD or GND with a resistor, if it is considered to have a possibility of being an output pin. All handling related to the unused pins must be judged device by device and related specifications governing the devices.

(3) Status before initialization of MOS devices

Power-on does not necessarily define initial status of MOS device. Production process of MOS does not define the initial operation status of the device. Immediately after the power source is turned ON, the devices with reset function have not yet been initialized. Hence, power-on does not guarantee out-pin levels, I/O settings or contents of registers. Device is not initialized until the reset signal is received. Reset operation must be executed immediately after power-on for devices having reset function.

Table of contents

Chapter 1	Overview	9
1.1	Naming	9
1.1.1	Alternative function pins	9
1.1.2	Power supply pins	9
1.2	Pin Groups	10
1.3	General measurement conditions	10
1.3.1	AC characteristic measurement condition	10
Chapter 2	Absolute maximum ratings	11
2.1	Supply voltages	11
2.2	Port voltages	12
2.3	Port current	13
2.4	Capacitance	13
2.5	Thermal characteristics	14
Chapter 3	Power supply specification	15
3.1	Requirements for external power supply connections	15
3.2	Power area definitions	15
3.3	Power supply groups	16
3.4	Supply voltages	17
3.4.1	AWO Regulator characteristics	18
3.4.2	ISO0/ISO1 Regulator characteristics (M1 products)	19
3.4.3	Amplifier characteristics (M2 products)	19
3.4.4	POC characteristics	21
3.4.5	Voltage Comparator characteristics	21
3.5	Power-up/down sequence of external supply voltages	22
3.5.1	External FLMDn Resistors	22
3.5.2	Condition 1	22
3.5.3	Condition 2	23
3.5.4	Condition 5	24
3.5.5	Condition 6	25
Chapter 4	Clock generators	26
4.1	CPU clock	26
4.2	Peripheral clock	26
4.3	Oscillator characteristics	26
4.3.1	Main oscillator	26
4.3.2	Sub-oscillator	27
4.3.3	Internal oscillator	28
4.4	PLL Characteristics	29
Chapter 5	I/O specification	30
5.1	Port Characteristics	30
5.1.1	Condition settings	30
5.1.2	PgE0	31
5.1.3	PgE1	32

5.1.4	PgB0	33
5.1.5	PgA0	34
Chapter 6 Supply current specification		35
6.1	Supply current of μ PDF70F4003 / μ PDF70F4004 / μ PDF70F4005 / μ PDF70F4006	35
6.2	Supply current of μ PDF70F3551 / μ PDF70F3552 / μ PDF70F3553 / μ PDF70F3554	36
6.3	Voltage Comparator characteristics	36
Chapter 7 Peripherals specification		37
7.1	Reset timing	37
7.2	NMI timing	37
7.3	INTP timing	38
7.4	FLMD0 timing	38
7.5	_DCUTRST timing	38
7.6	Timer timing	39
7.7	CSI timing	41
	7.7.1 Master modes	41
	7.7.2 Slave mode	47
7.8	UART timing	50
7.9	FCN timing	51
7.10	FlexRay timing	52
7.11	IIC timing	54
7.12	Frequency Output Function (FOUT)	56
7.13	VLVI characteristics	56
7.14	Voltage comparator characteristics	57
7.15	LVI characteristics	58
7.16	A/D Converter characteristics	59
	7.16.1 12bit A/D (for ADC channels without S/H functionality)	59
	7.16.2 12bit A/D (For channel ADCA0I0-5 when the S/H function is not used) . . .	60
	7.16.3 12bit A/D (When channel S/H function is used)	61
	7.16.4 10bit A/D (for ADC channels without S/H functionality)	62
	7.16.5 10bit A/D (For channel ADCA0I0-5 when the S/H function is not used) . . .	63
	7.16.6 10bit A/D (When channel S/H function is used)	64
	7.16.7 Equivalent circuit	65
	7.16.8 ADTRG timing	65
7.17	Key Return	66
Chapter 8 Memory specification		67
8.1	Code flash specification	67
8.2	Data flash specification	67
8.3	Serial write operation specification	67
Chapter 9 Pinning and package specification		68
9.1	Pinning specification	68
9.2	Package specification	70
Chapter 10 Definition of terms		71
10.1	How to Read A/D Converter Characteristics Table	71

Chapter 1 Overview

1.1 Naming

1.1.1 Alternative function pins

Peripheral	Prefix	Function name	Suffix
Short-cut of macro name	Consecutive number for same peripheral module ^a	Peripheral Macro pin naming	Consecutive number for same pin names ^a

a) This is an option that can be omitted if meaning is obvious

Example:

- TAUB0I0, TAUB1I5
- URTE0TX, URTE0RX, URTE1TX, URTE1RX
- CSIG0SO, CSIG0SI, CSIG0SC, CSIG0RY

1.1.2 Power supply pins

Function	Prefix	Kind of supply	Suffix
Symbol	Consecutive number for different functions ^a	VDD or VSS	Consecutive number for different pins with same meaning ^a

a) This is an option that can be omitted if meaning is obvious

Example:

- E0VDDn, REG0VSS

Table 1-1 Selection for Functions

Function	Explanation
C	Core supply
REG	Internal regulator supply
OSC	Oscillator supply
F	Flash module supply
E	Standard buffer supply (mainly 5V or up to 40Mhz)
B	Standard buffer supply (mainly 3.3V or beyond 40Mhz)
A	Analog module supply (e.g. ADC)

If not mentioned otherwise this document neglects suffixes for power supply pins with same functions that can be treated as equal.

1.2 Pin Groups

Symbol	Pin group supplied by	Related pins / ports
PgE0	E0VDD	JP0, P0, _RESET, FLMD0, WAKE, VCPC0IN, VCPC1IN
PgE1	E1VDD / E1VSS	P1, P2, P3, P4
PgB0	B0VDD / B0VSS	P21, P25, P27
PgOSC	OSCVDD / OSCVSS	X1, X2, XT1, XT2
PgA0	A0VDD / A0VSS	P10, P11, ADCA0Im

1.3 General measurement conditions

1.3.1 AC characteristic measurement condition

AC test input waveform

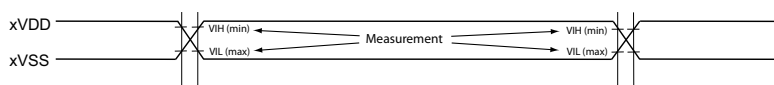

AC test output waveform

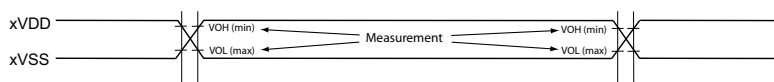

Standard AC test condition is 70%/30% of the applied IO supply voltage ($XmVDD$) if not otherwise stated in the according AC timing specification of an interface.

AC Test Condition: Ext. Capacitive Load

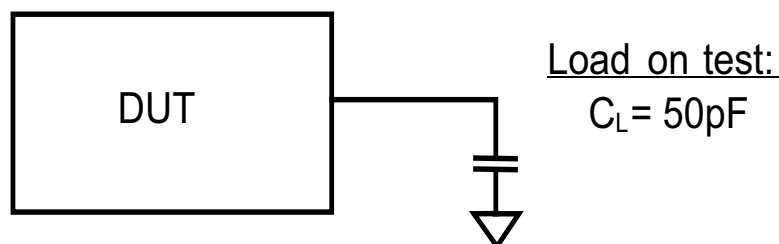

Chapter 2 Absolute maximum ratings

2.1 Supply voltages

Table 2-1 VDD Data

Parameter	Symbol	Condition	Ratings	Unit
System	CVDD	M2 products only	-0.5 ~ 1.6	V
System	FVDD		-0.5 ~ 6.0	V
	OSCVDD		-0.5 ~ 6.0	V
	REG0VDD		-0.5 ~ 6.0	V
	REG1VDD		-0.5 ~ 6.0	V
	REG2VDD		-0.5 ~ 6.0	V
	REG3VDD		-	V
Ports	E0VDD		-0.5 ~ 6.0	V
	E1VDD		-0.5 ~ 6.0	V
Port	B0VDD		-0.5 ~ 6.0	V
ADCA0	A0VREFP		-0.3 ~ A0VDD+0.3 -0.3~6.0	V
ADCA0	A0VDD		-0.5 ~ 6.0	V
ADCA1	A1VDD		n.a.	V
	A1VREFP		n.a.	V

Table 2-2 VSS Data

Parameter	Symbol	Condition	Ratings	Unit
System	CVSS	M2 products only	-0.5 ~0.5	V
System	FVSS		-0.5 ~0.5	V
	OSCVSS		-0.5 ~0.5	V
	REG0VSS		-0.5 ~0.5	V
	REG1VSS		-0.5 ~0.5	V
	REG2VSS		-0.5 ~0.5	V
	REG3VSS		-	V
Ports	E1VSS		-0.5 ~0.5	V
	B0VSS		-0.5 ~0.5	V
ADC0	A0VSS		-0.5 ~0.5	V
	A0VREFM		-0.3 ~ A0VDD+0.3 -0.3~6.0	V

2.2 Port voltages

Table 2-3 Port Input voltage

Parameter	Pin Group	Symbol ^a	Condition	Ratings	Unit
Input voltage ^b	PgE0	V_{10}	$E0VDD \leq 5.5$	$-0.5 \sim E0VDD + 0.5$	V
	PgE1	V_{11}	$E1VDD \leq 5.5$	$-0.5 \sim E1VDD + 0.5$	V
	PgB0	V_{12}	$B0VDD \leq 5.5$	$-0.5 \sim B0VDD + 0.5$	V
	PgOSC	V_{15}	$OSCVDD \leq 5.5$	$-0.5 \sim OSCVDD + 0.5$	V
	PgA0	V_{13}		$A0VDD + 0.3$	V
	PgA1	V_{14}		n.a.	V

- a) The symbols reflect all supplies within the device series. Therefore not every symbol is available for each product.
- b) The characteristics of the alternative-function pins are the same as those of the port pins unless otherwise specified.

2.3 Port current

Table 2-4 High level port output current

Parameter	Pin Group ^a	Symbol	Condition	Max. spec	Unit
High level output current	PgE0	IOH	1 pin of PgE0	-10	mA
			Power supply of PgE0	-50	
	PgE1		1 pin of PgE1	-10	
			Power supply of PgE1	-100	
	PgA0		1 pin of PgA0	-10	
			Power supply of PgA0	-25	
High level output current	PgA1	1 pin of PgA1	n.a.	mA	
		Power supply of PgA1	n.a.		
High level output current	Pgb0	1 pin of Pgb0	-10	mA	
		Power supply of Pgb0	-100		

a) The column reflects all supplies within the device series. Therefore not each pin group is available for each product.

Table 2-5 Low level port output current

Parameter	Pin Group ^a	Symbol	Condition	Max. spec	Unit
Low level output current	PgE0	IOL	1 pin of PgE0	10	mA
			Power supply of PgE0	50	
	PgE1		1 pin of PgE1	10	
			Power supply of PgE1	100	
	PgA0		1 pin of PgA0	10	
			Power supply of PgA0	25	
Low level output current	PgA1	1 pin of PgA1	n.a.	mA	
		Power supply of PgA1	n.a.		
Low level output current	Pgb0	1 pin of Pgb0	10	mA	
		Power supply of Pgb0	100		

a) The column reflects all supplies within the device series. Therefore not each pin group is available for each product.

2.4 Capacitance

Parameter	Symbol	Condition	Max. spec	Unit
Input capacitance	C_I	f = 1 MHz 0V for non measurement pins	15	pF
Input/Output capacitance	C_{IO}		15	pF
Output capacitance	C_O		15	pF

2.5 Thermal characteristics

Table 2-6 Thermal characteristics

Parameter	Symbol	Condition	Ratings	Unit
Storage temperature	T_{STG}		-65 ~150	°C
Operating ambient temperature	T_a	(A) grade products	-40 ~85	
		(A1) grade products	-40 ~110	
		(A2) grade products	-40 ~125	
Junction temperature	T_j		-40 ~150	

This section specifies the absolute maximum limitation of operating and storage temperature.

The device's functions are not guaranteed outside of the specified maximum temperature ratings.

Chapter 3 Power supply specification

3.1 Requirements for external power supply connections

The user has to ensure a low resistive connection of all VSS pins on the PCB. This specification denotes ground supply pins as:

- VSS = OSCVSS = REGnVSS = EnVSS = BnVSS = AnVSS = AnVREM = CVSS = 0V

in the further text.

With

- EnVSS = E1VSS
- BnVSS = B0VSS
- REGnVSS = REG0VSS = REG1VSS = REG2VSS
- AnVSS = A0VSS AnVREFM = A0VREFM

The user has to ensure a low resistive connection of all VDD pins to the related power supply. This specification denotes power supply pins as:

- EnVDD, BnVDD, FVDD, REGnVDD, OSCVDDCVDD, AnVDD and AnVREFP.

in the further text.

With

- EnVDD = E0VDD = E1VDD
- BnVDD = B0VDD
- REGnVDD = REG0VDD = REG1VDD = REG2VDD.
- AnVDD = A0VDD
- AnVREFP = A0VREFP
- I/OVDD = AnVDD, EnVDD, B0VDD, FVDD, OSCVDD

3.2 Power area definitions

The device consists of the following power areas:

- AWO (Always On area)
- ISO0 (Isolated area 0)
- ISO1 (Isolated area 1)

The table below lists the related core and port voltage supply of each power area:

Table 3-1 Power areas supply voltages

Power Area	Supply voltage	Related pins
AWO	Core supply	REG0VDD, REG0VSS, REG0C
	Port Supply	E0VDD
	Other	OSCVDD, OSCVSS FVDD0
ISO0	Core supply	REG1VDD, REG1VSS, REG1C REG2VDD, REG2VSS, REG2C
	Port Supply	E1VDD, E1VSS
	Other	A0VREFP, A0VREFM A0VDD, A0VSS
ISO1	Core supply	REG1VDD, REG1VSS, REG1C REG2VDD, REG2VSS, REG2C CVDD, CVSS
	Port Supply	B0VDD, B0VSS
	Other	n.a.

3.3 Power supply groups

For each of the following power supply groups the same voltage must be supplied:

Table 3-2 Power supply groups

Power supply group	Related pins
#1	REG0VDD, REG1VDD, FVDD, OSCVDD, E0VDD, E1VDD
#2	B0VDD
#3	M1 products: REG2VDD M2 products: n.a.
#4	M1 products: n.a. M2 products: CVDD
#5	A0VDD, A0VREFP
#6	A1VDD, A1VREFP
#7	All VSS

3.4 Supply voltages

Table 3-3 VDD Data

Parameter	Symbol	Condition	Ratings			Unit
			Min	Typ	Max	
System supply voltage	FVDD		VPOC	-	5.5	V
System supply voltage	OSCVDD		VPOC	-	5.5	V
System supply voltage	REG0VDD	REG0VDD = REG1VDD = REG2VDD	VPOC	-	5.5	V
System supply voltage	REG1VDD		VPOC	-	5.5	V
System supply voltage	REG2VDD		VPOC	-	5.5	V
System supply voltage	REG3VDD		-	-	-	V
System supply voltage	CVDD	M2 products only	1.1	-	1.3	V
System supply voltage slopes	AIVS	M2 products; REG1VDD = 3.0V to 5.5V	-	-	5.6	V/ms
Port supply voltages	E0VDD		VPOC	-	5.5	V
Port supply voltages	E1VDD		VPOC	-	5.5	V
Port supply voltages	B0VDD	B0VDD ≤ power supply group #1 voltages	VPOC	-	5.5	V
ADC supply voltages	A0VDD	12bit resolution	4.5	-	5.5	V
ADC supply voltages	A0VDD	10bit resolution	VPOC	-	5.5	V
ADC supply voltages	A0VREFP		A0VDD	-	A0VDD	V

3.4.1 AWO Regulator characteristics

Table 3-4 AWO Regulator characteristics

Parameter	Symbol	Condition	Ratings			Unit
			Min	Typ	Max	
Regulator Output voltage	VRO		1.1	1.2	1.3	V
System supply voltage slope	RAVS	0V to 3.0V	-	-	1800	V/ms
Capacitance on REG0C	REG0C		3.29	4.7	6.11	μF
Output voltage stabilization time	TRAA	After REG0VDD reaches 3.0V	-	-	1	ms
		After DeepStop mode	-	-	0.5	ms

During power-up sequence

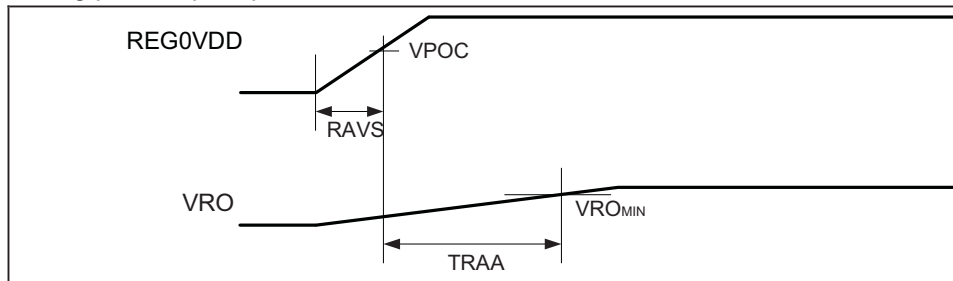

After DeepStop mode

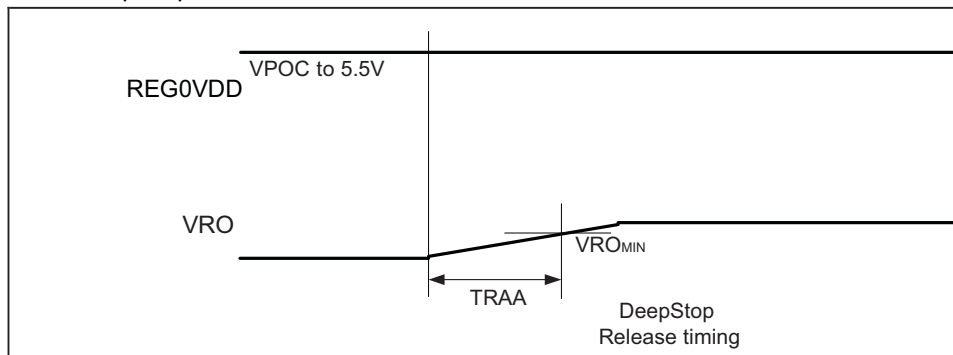

3.4.2 ISO0/ISO1 Regulator characteristics (M1 products)

Table 3-5 ISO0/ISO1 regulator characteristics

Parameter	Symbol	Condition	Ratings			Unit
			Min	Typ	Max	
Output voltage	VROI		1.1	1.2	1.3	V
Capacitance on REGnC	REGnC		3.29	4.7	6.11	μF
Voltage slope	RIVS	0V to 5.5V	-	-	5600	V/s
Output voltage stabilization time	TRAJ	After REGnVDD reaches 3.0V	-	-	1	ms
		After DeepStop mode	-	-	0.5	ms

Note n=1-2

During power-up sequence

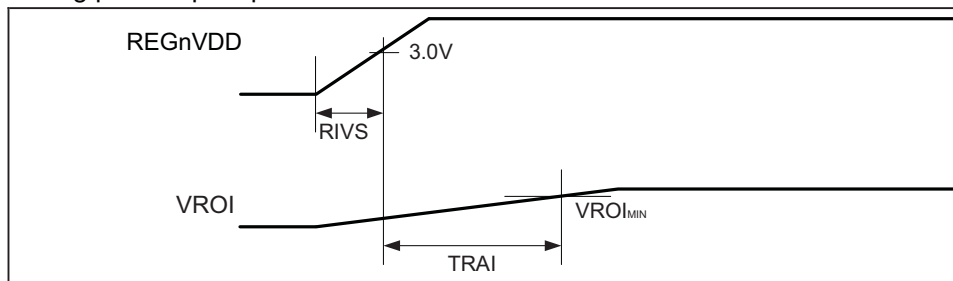

After DeepStop mode

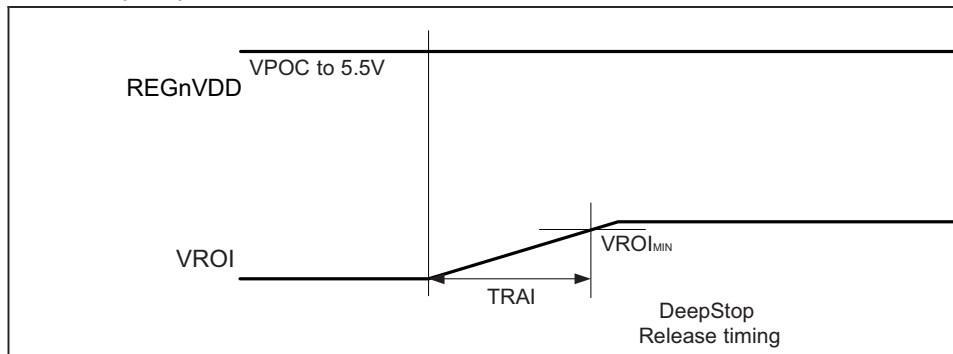

3.4.3 Amplifier characteristics (M2 products)

Parameter	Symbol	Condition	Ratings			Unit
			Min	Typ	Max	
System supply voltage	REG1VDD		VPOC		5.5	V
Capacitance on CVDD	CVDDC	For each CVDD ^a	3.29	4.7	6.11	μF
Voltage slope	AIVS	3.0V to 5.5V	-	-	5.6	V/ms
PTCTL1 stabilization time	TRAJ	After REG1VDD reaches 3.0V	-	-	1	ms
		After DeepStop mode	-	-	0.5	ms
PTCTL1 output current	IPTCTL		-	-	1.55	mA

a) Required when using an external power transistor such as 2SD1584 (base connected to PTCTL1)

During power-up sequence

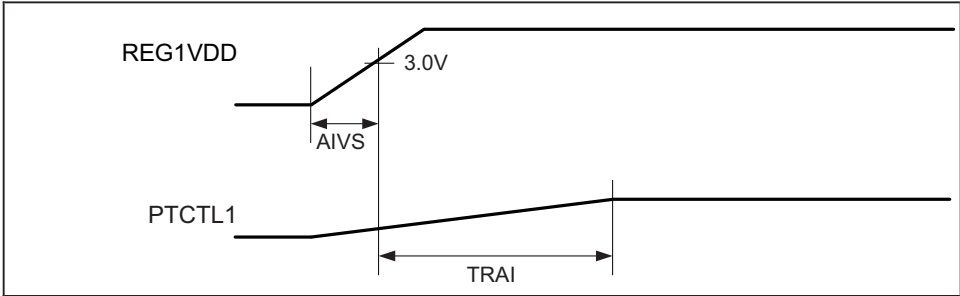

After DeepStop mode

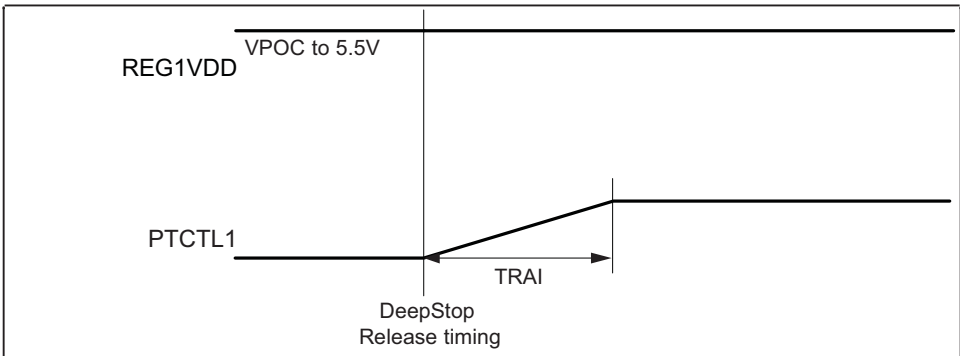

3.4.4 POC characteristics

Table 3-6 POC characteristics

Parameter	Symbol	Condition	Ratings			Unit
			Min	Typ	Max	
Detection voltage	VPOC		2.8	2.9	3.0	V
Voltage slope 1	PVS1		0.18	-	1800	V/ms
Voltage slope 2	PVS2		0.0018	-	1800	V/ms
Response time 1	tPTH	From detect voltage to release of reset signal. Voltage slope = PVS1, PVS2	-	-	2	ms
Response time 2	tPD	From detect voltage to occurrence of reset signal Voltage slope = PVS2	-	-	2	ms
VDD minimum width	tPW		0.2	-	-	ms

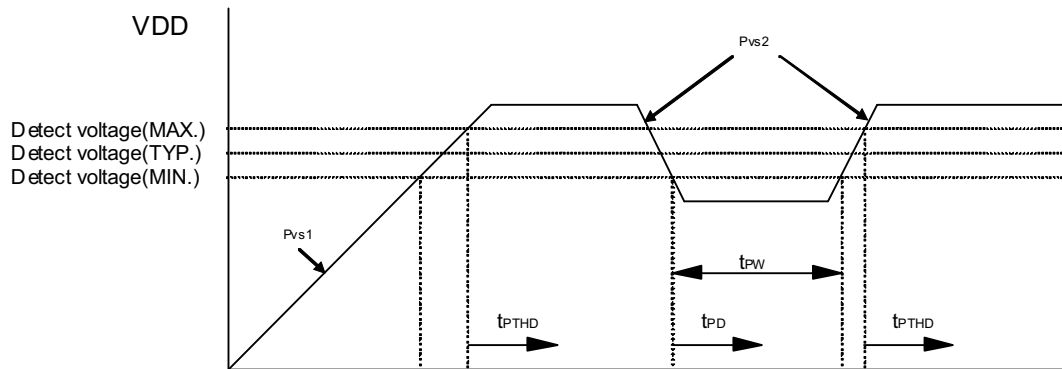

3.4.5 Voltage Comparator characteristics

Table 3-7 VCMP characteristics

Parameter	Symbol	Condition	Ratings			Unit
			Min	Typ	Max	
Input voltage range of VCPCnIN	VICMP		REG0VSS	-	REG0VDD	V

Note VDD: REG0VDD

3.5 Power-up/-down sequence of external supply voltages

3.5.1 External FLMDn Resistors

Valid for all conditions described in the following

Parameter	Symbol	Condition	Ratings			Unit
			Min	Typ	Max	
FLMD0 external pull-down resistor	R1		82	-	-	k Ω
FLMD1 external pull-down resistor	R2		-	10	-	k Ω

3.5.2 Condition 1

M1 products: RESET is not used

M2 products: RESET, WAKE and PTCTL1 are not used

Normal operating mode

Parameter	Symbol	Condition	Ratings			Unit
			Min	Typ	Max	
REG0VDD, REG1VDD, IOVDD (rise) to CVDD (rise)	tROCON		1	-	10	ms
REG0VDD, IOVDD (rise) to FLMD0,1 (\leq VIL) hold time	tROMDH		2	-	-	ms
FLMD0,1 (\leq VIL) to REG0VDD, IOVDD (fall)	tMDR0OF		0	-	-	ms
CVDD (0V) to REG0VDD, IOVDD (fall)	tCR0OF		0	-	-	ms

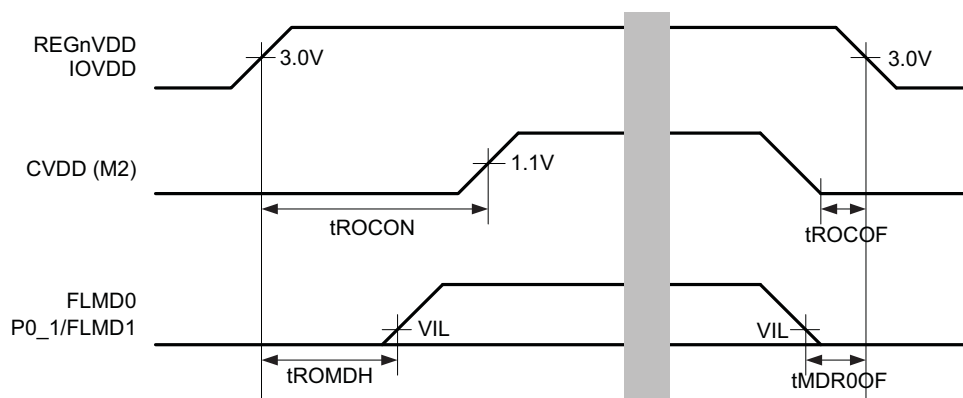

Note IOVDD: AnVDD, B0VDD, EnVDD, FVDD, OSCVDD

3.5.3 Condition 2

M1 products: RESET is used

M2 products: RESET is used; WAKE and PTCTL1 are not used

Normal operating mode / Serial programming mode

Parameter	Symbol	Condition	Ratings			Unit
			Min	Typ	Max	
REGnVDD, IOVDD (rise) to CVDD (0V) hold time	tR0CH		1	-	-	ms
REG0VDD, REG1VDD, IOVDD (rise) to FLMD0,1(\leq VIL) hold time	tROMDH		1	-	-	ms
CVDD (rise) to _RESET (rise)	tCRR		0	-	-	ms
FLMD0,1 (\geq VIH or VIL1) ^a to _RESET(\leq VIL) (rise)	tMDRR		1	-	-	ms
_RESET (rise) to FLMD0,1(\geq VIH or \leq VIL) hold time	tRMDH		1	-	-	ms
FLMD0,1,MODE0,1(\leq VIL) to _RESET (\geq VIH) (fall) setup time	tMDRF		0	-	-	ms
_RESET (fall) to CVDD (fall)	tRCF		0	-	-	ms
CVDD (0V) to REGnVDD, IOVDD (fall)	tCROOF		0	-	-	ms
_RESET (\leq VIL) (fall) to REGnVDD, IOVDD (fall) hold time	tRR0OF		0	-	-	ms

a) In case of BSCAN mode set also the MODE0,1 pins.

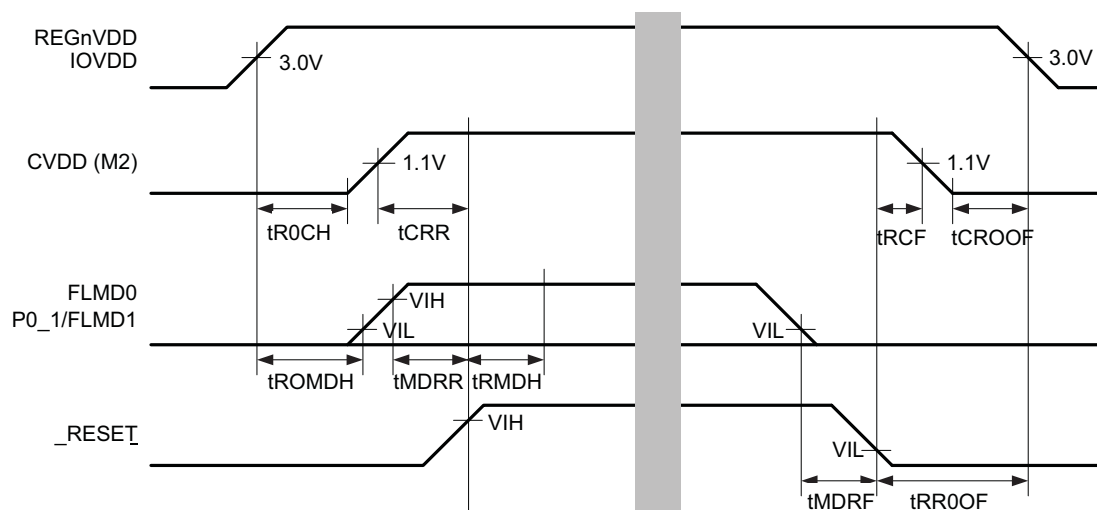

Note There is no specification for _RESET rise and fall times.

3.5.4 Condition 5

M2 products only. RESET is not used; PTCTL1 is used

Normal operating mode

Parameter	Symbol	Condition	Ratings			Unit
			Min	Typ	Max	
REG0VDD, REG1VDD, IOVDD (rise) to PTCTL1 (rise) setup time	tR1PTON		-	-	1	ms
REG0VDD, REG1VDD, IOVDD (rise) to CVDD (rise) byPTCTL1 (rise)	tR0CON		1	-	10	ms
REG0VDD, REG1VDD, IOVDD (rise) to FLMD0,1(≤VIL) hold time	tR0MDH		2	-	-	ms
FLMD0,1 (≤VIL) to REG0VDD, REG1VDD, IOVDD (fall)	tMDR0OF		0	-	-	ms
REG0VDD, REG1VDD, IOVDD (fall) to PTCTL1 (fall)	tR1PTOF		-	-	1	ms
PTCTL1 (fall) to CVDD (fall)	tPTCOF		0	-	8	ms

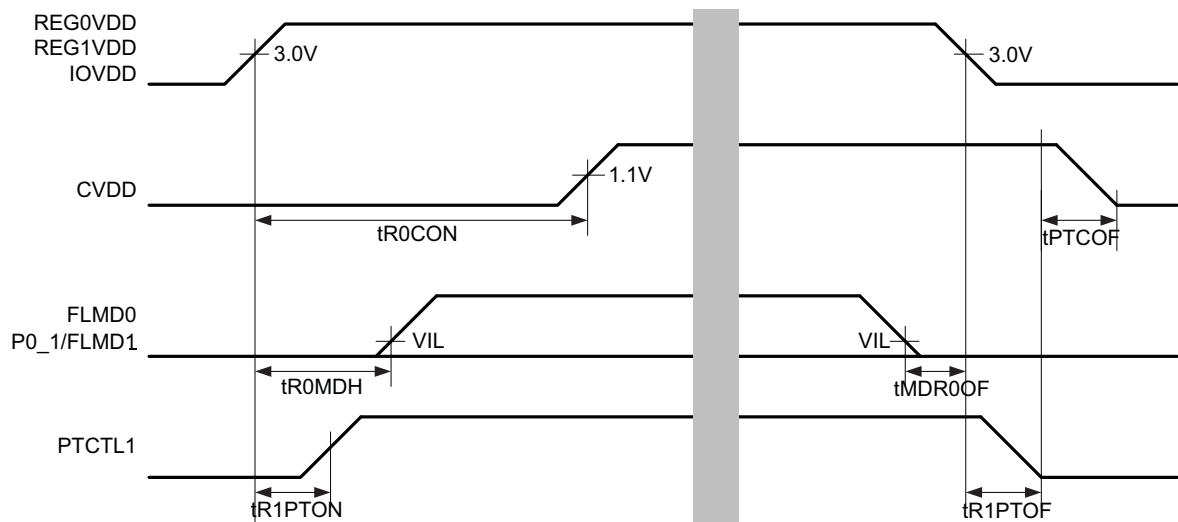

3.5.5 Condition 6

M2 products only. RESET is used; PTCTL1 is used

Normal operating mode / Serial programming mode / BSCAN mode

Parameter	Symbol	Condition	Ratings			Unit
			Min	Typ	Max	
REG0VDD, REG1VDD, IOVDD (rise) to CVDD (0V) hold time	tR0CH		-	-	1	ms
REG1VDD (rise) to PTCTL1 (rise) setup time	tR1PTON		-	-	1	ms
REG0VDD, IOVDD (rise) to FLMD0,1 (\leq VIL) hold time	tR0MDH		1	-	-	ms
CVDD (rise) to _RESET (rise)	tCRR		0	-	-	ms
FLMD0,1 (VIH or VIL) ^a to _RESET (rise)	tMDRR		1	-	-	ms
_RESET (rise) to FLMD0,1 (VIH or VIL) hold time	tRMDH		1	-	-	ms
FLMD0,1,MODE0,1 (\leq VIL) ^a to _RESET (fall)	tMDRF		0	-	-	ms
_RESET (fall) to REG0VDD, IOVDD (fall)	tRR0OF		0	-	-	ms
REG1VDD (fall) to PTCTL1 (fall)	tR1PTOF		-	-	1	ms
PTCTL1 (fall) to CVDD (fall)	tPTCOF		0	-	8	ms

a) In case of BSCAN mode set also the MODE0,1 pins.

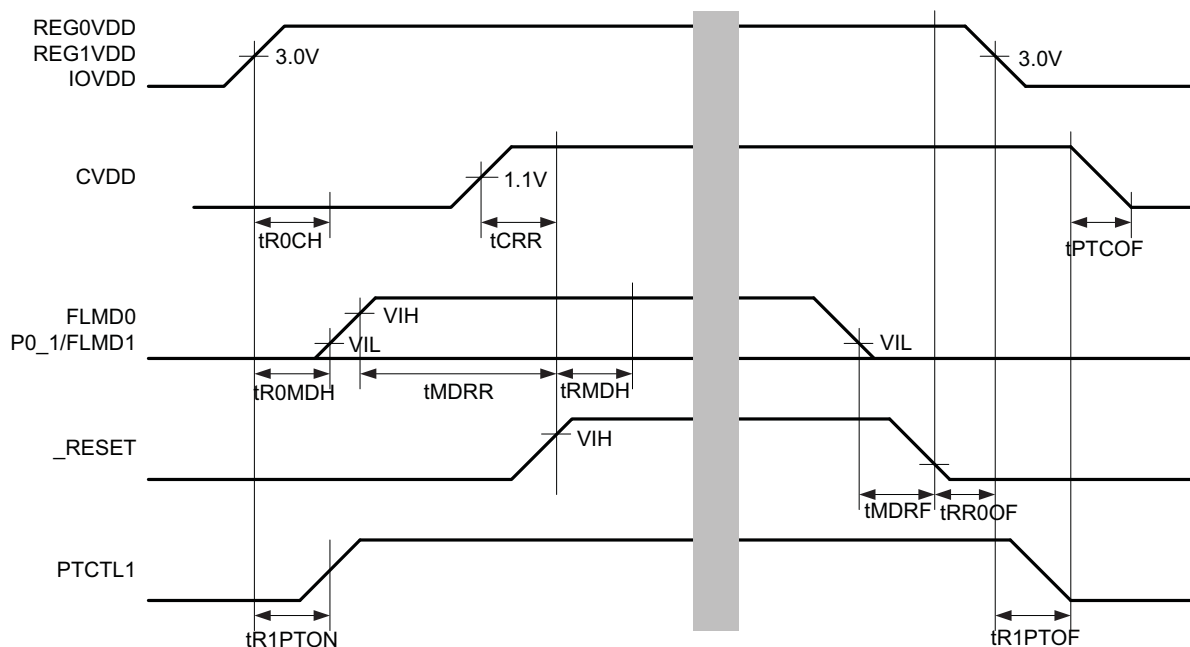

Note There is no specification for _RESET rise and fall times.

Chapter 4 Clock generators

4.1 CPU clock

Table 4-1 CPU clock frequency

Parameter	Symbol	Condition	Ratings			Unit
			Min	Typ	Max	
CPU clock frequency	fCPU	PLL based	-	-	80	MHz
		SSCG based	-	-	88.32	MHz

4.2 Peripheral clock

Table 4-2 Peripheral clock frequency

Parameter	Symbol	Condition	Ratings			Unit
			Min	Typ	Max	
Peripheral clock frequency	fPERI		-	-	48 ^a	MHz

a) Some peripherals can be operated at 80MHz. Refer to the chapter 'Clock Selection' in the UM for details.

4.3 Oscillator characteristics

4.3.1 Main oscillator

A ceramic or crystal resonator can be connected to the main clock input pins as shown in figure 4-1 "Recommended Main Oscillator Circuit"

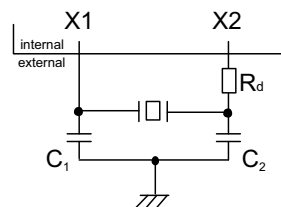

Figure 4-1 Recommended Main Oscillator Circuit

Caution Values of C_1 , C_2 and R_d and the best setting for MOSCC.AMPSEL[1:0] register depend on the used ceramic or crystal resonator and must be specified in cooperation with ceramic or crystal resonator manufacturer.

The main oscillator amplifier gain for the external resonator can be selected by MOSCC.MOSCCAMPSEL[1:0]. Thereby it can be adjusted to support a wide range of frequencies to cope with different external resonators and their external circuitry.

As an example a typical setting for quartz crystals is shown in Table 4-3 “Typical setting of MOSCC.AMPSEL[1:0] for different quartz crystals frequencies”.

Note For details to the setting of MOSCC.MOSCCAMPSEL[1:0] please refer to the user manual.

Table 4-3 Typical setting of MOSCC.AMPSEL[1:0] for different quartz crystals frequencies

MOSCC.AMPSEL[1:0]	Amplification gain	Typical condition for quartz crystals
00	high	$16 < f_{\text{MOSC}} \leq 20$ MHz
01	medium	$8 < f_{\text{MOSC}} \leq 16$ MHz
10	low	$4 < f_{\text{MOSC}} \leq 8$ MHz
11	very low	4 MHz

(1) Main oscillator characteristics

Table 4-4 Main oscillator characteristics

Parameter	Symbol	Condition	Ratings			Unit
			Min	Typ	Max	
MainOSC frequency	f_{MOSC}		4	-	20	MHz

- Cautions**
1. External clock input is prohibited.
 2. General guidance for PCB layout:
 - Keep the wiring length as short as possible.
 - Do not cross the wiring with other signal lines.
 - Do not route this circuit close to a signal line with high fluctuating current flow.
 - Always make the ground point of the oscillator capacitor the same potential as REG0VSS and OSCVSS.
 - Do not ground the capacitor to a ground pattern with high current flow.
 - Do not tap signals from the oscillator.

4.3.2 Sub-oscillator

A crystal resonator can be connected to the sub clock input pins as shown in figure 4-2 “Recommended Sub Oscillator Circuit”

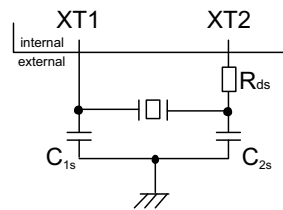

Figure 4-2 Recommended Sub Oscillator Circuit

Caution Values of C_{1s} , C_{2s} and R_{ds} depend on the used crystal and must be specified in cooperation with crystal manufacturer.

(1) Sub-oscillator characteristics

Table 4-5 Sub-oscillator characteristics

Parameter	Symbol	Condition	Ratings			Unit
			Min	Typ	Max	
MainOSC frequency	fSOSC		-	32.768	-	kHz

4.3.3 Internal oscillator

Table 4-6 Internal oscillator characteristics

Parameter	Symbol	Condition	Ratings			Unit
			Min	Typ	Max	
Lowspeed OSC frequency	fRL	<ul style="list-style-type: none"> Other than DeepStop mode DeepStop mode with PSC0.REGSTP = 0 	220.8	240	259.2	kHz
	fRLLP	<ul style="list-style-type: none"> DeepStop mode with PSC0.REGSTP = 1 	216	240	264	kHz
Highspeed OSC frequency	fRH	<ul style="list-style-type: none"> Other than DeepStop mode DeepStop mode with PSC0.REGSTP = 0 	7.2	8.0	8.8	MHz
	fRHLP	<ul style="list-style-type: none"> DeepStop mode with PSC0.REGSTP = 1 	6.64	8.0	8.8	MHz
Highspeed OSC stabilization time	TRHSTB		-	-	19	μ s

4.4 PLL Characteristics

Table 4-7 PLL characteristics

Parameter	Symbol	Condition	Ratings			Unit
			Min	Typ	Max	
Input frequency	fxn	PLL mode and SSCG mode	4	-	20	MHz
Output frequency	fxxn	PLL mode	25	-	80	MHz
		SSCG mode	22.40	-	88.32	MHz
Lock time	TLCKPn	PLL mode	-	-	650	μs
	TLCKSn	SSCG mode	-	-	1300	μs
Period jitter ^a	tPJn	Peak to peak, fixed frequency mode, Pr=2	-150	-	150	ps
Long term jitter ^a	tLTJn	PLL mode, Peak to peak, term=1μs fVCOOUT=160MHz (Pr=2)	-1.275	-	1.275	ns

^{a)} Not tested in production. Specified by design.

Chapter 5 I/O specification

5.1 Port Characteristics

5.1.1 Condition settings

Some of the conditions mentioned in this chapter can be selected by software. The related register settings are described below:

(1) Input characteristic

The input characteristics can be selected by the registers PIS and PISE with the following coding:

Table 5-1 Input characteristic selection

PISE	PIS	Reference in UserManual	Electrical characteristic
0	0	Type 1	CMOS ^a
0	1	Type 2	Schmitt2
1	0	Type 3	Schmitt1
1	1	Type 4	Schmitt4

^{a)} Default setting after reset

5.1.2 PgE0

Table 5-2 PgE0 characteristics

Parameter	Symbol	Condition	Ratings			Unit
			Min	Typ	Max	
High level input voltage	VIH	CMOS	$0.7 \cdot E0VDD$	-	$E0VDD+0.3$	V
		Schmitt1	$0.7 \cdot E0VDD$	-	$E0VDD+0.3$	
		Schmitt2	$0.8 \cdot E0VDD$	-	$E0VDD+0.3$	
		Schmitt4 ($E0VDD=VPOC \sim 3.0$)	$0.84 \cdot E0VDD$	-	$E0VDD+0.3$	
		Schmitt4 ($E0VDD=3.0 \sim 5.5$)	$0.8 \cdot E0VDD$	-	$E0VDD+0.3$	
Low level input voltage	VIL	CMOS	-0.5	-	$0.3 \cdot E0VDD$	V
		Schmitt1	-0.5	-	$0.3 \cdot E0VDD$	
		Schmitt2	-0.5	-	$0.2 \cdot E0VDD$	
		Schmitt4 ($E0VDD=VPOC \sim 3.0$)	-0.5	-	$0.4 \cdot E0VDD$	
		Schmitt4 ($E0VDD=3.0 \sim 5.5$)	-0.5	-	$0.5 \cdot E0VDD$	
High level output voltage	VOH	IOH = -5mA	$E0VDD-1.0$	-		V
		IOH = -100 μ A	$E0VDD-0.5$	-		
Low level output voltage	VOL	IOL = 5mA	-	-	0.4	V
		IOL = 100 μ A	-	-	0.4	
Input hysteresis of Schmit	VH	Schmitt1	0.3	-		V
		Schmitt2	0.3	-		
		Schmitt4	0.1	-		
Internal pull-up resistor	RU		20	40	100	k Ω
Internal pull-down resistor	RD		20	40	100	k Ω
High level port output current	IOH	Power supply of PgE0	-	-	-20	mA
Low level port output current	IOL	Power supply of PgE0	-	-	20	mA
High level input leakage current	ILIH	VI = E0VDD	-	-	0.5	μ A
Low level input leakage current	ILIL	VI = 0V	-	-	-0.5	μ A
High level output leakage current	ILOH	VO = E0VDD	-	-	0.5	μ A
Low level output leakage current	ILOL	VO = 0V	-	-	-0.5	μ A
Output frequency	fO	Slow mode	-	-	25	MHz
		Fast mode	-	-	40	
Rise time (output)	tKRP	Slow mode	-	-	15	ns
		Fast mode	-	-	8	
Fall time (output)	tKFP	Slow mode	-	-	15	ns
		Fast mode	-	-	8	

5.1.3 PgE1

Table 5-3 PgE1 characteristics

Parameter	Symbol	Condition	Ratings			Unit
			Min	Typ	Max	
High level input voltage	VIH	CMOS	0.7·E1VDD	-	E1VDD+0.3	V
		Schmitt1	0.7·E1VDD	-	E1VDD+0.3	
		Schmitt2	0.8·E1VDD	-	E1VDD+0.3	
		Schmitt4 (E1VDD=VPOC~3.0)	0.84·E1VDD	-	E1VDD+0.3	
		Schmitt4 (E1VDD=3.0~5.5)	0.8·E1VDD	-	E1VDD+0.3	
Low level input voltage	VIL	CMOS	-0.5	-	0.3·E1VDD	V
		Schmitt1	-0.5	-	0.3·E1VDD	
		Schmitt2	-0.5	-	0.2·E1VDD	
		Schmitt4 (E1VDD=VPOC~3.0)	-0.5	-	0.4·E1VDD	
		Schmitt4 (E1VDD=3.0~5.5)	-0.5	-	0.5·E1VDD	
High level output voltage	VOH	IOH = -5mA ^a	E1VDD-1.0	-		V
		IOH = -100μA	E1VDD-0.5	-		
Low level output voltage	VOL	IOL = 5mA ^a	-	-	0.4	V
		IOL = 100μA	-	-	0.4	
Input hysteresis of Schmit	VH	Schmitt1	0.3	-		V
		Schmitt2	0.3	-		
		Schmitt4	0.1	-		
Internal pull-up resistor	RU		20	40	100	kΩ
Internal pull-down resistor	RD		20	40	100	kΩ
High level port output current	IOH	Power supply of PgE1	-	-	-150	mA
Low level port output current	IOL	Power supply of PgE1	-	-	150	mA
High level input leakage current	ILIH	VI = E1VDD	-	-	0.5	μA
Low level input leakage current	ILIL	VI = 0V	-	-	-0.5	μA
High level output leakage current	ILOH	VO = E1VDD	-	-	0.5	μA
Low level output leakage current	ILOL	VO = 0V	-	-	-0.5	μA
Output frequency	fO	Slow mode	-	-	25	MHz
		Fast mode	-	-	40	
Rise time (output)	tKRP	Slow mode	-	-	15	ns
		Fast mode	-	-	8	ns
Fall time (output)	tKFP	Slow mode	-	-	15	ns
		Fast mode	-	-	8	ns

a) The maximum number of PgE1 pins with 'ON' signal at the same time is 5 in 'Slow mode'.
The maximum number of PgE1 pins with 'ON' signal at the same time is 8 in 'Fast mode'.
See the UM for the related description of the Port drive strength control.

5.1.4 PgB0

Table 5-4 PgB0 characteristics

Parameter	Symbol	Condition	Ratings			Unit
			Min	Typ	Max	
High level input voltage	VIH	CMOS	0.7·B0VDD	-	B0VDD+0.3	V
		Schmitt1	0.7·B0VDD	-	B0VDD+0.3	
		Schmitt2	0.8·B0VDD	-	B0VDD+0.3	
		Schmitt4 (B0VDD=VPOC~3.0)	0.84·B0VDD	-	B0VDD+0.3	
		Schmitt4 (B0VDD=3.0~5.5)	0.8·B0VDD	-	B0VDD+0.3	
Low level input voltage	VIL	CMOS	-0.5	-	0.3·B0VDD	V
		Schmitt1	-0.5	-	0.3·B0VDD	
		Schmitt2	-0.5	-	0.2·B0VDD	
		Schmitt4 (B0VDD=VPOC~3.0)	-0.5	-	0.4·B0VDD	
		Schmitt4 (B0VDD=3.0~5.5)	-0.5	-	0.5·B0VDD	
High level output voltage	VOH	IOH = -5mA ^a	B0VDD-1.0	-	-	V
		IOH = -100μA	B0VDD-0.5	-	-	
Low level output voltage	VOL	IOL = 5mA ^a	-	-	0.4	V
		IOL = 100μA	-	-	0.4	
Input hysteresis of Schmit	VH	Schmitt1	0.3	-	-	V
		Schmitt2	0.3	-	-	
		Schmitt4	0.1	-	-	
Internal pull-up resistor	RU		20	40	100	kΩ
Internal pull-down resistor	RD		20	40	100	kΩ
High level port output current	IOH	Power supply of PgB0	-	-	-100	mA
Low level port output current	IOL	Power supply of PgB0	-	-	100	mA
High level input leakage current	ILIH	VI = B0VDD	-	-	0.5	μA
Low level input leakage current	ILIL	VI = 0V	-	-	-0.5	μA
High level output leakage current	ILOH	VO = B0VDD	-	-	0.5	μA
Low level output leakage current	ILOL	VO = 0V	-	-	-0.5	μA
Output frequency	fO	Slow mode	-	-	25	MHz
		Fast mode	-	-	40	
Rise time (output)	tKRP	Slow mode	-	-	15	ns
		Fast mode	-	-	8	
Fall time (output)	tKFP	Slow mode	-	-	15	ns
		Fast mode	-	-	8	

a) The maximum number of PgB0 pins with 'ON' signal at the same time is 5 in 'Slow mode' (Except the pins related to the external memory interface (MEMC)).
The maximum number of PgB0 pins with 'ON' signal at the same time is 8 in 'Fast mode'.
See the UM for the related description of the Port drive strength control.

5.1.5 PgA0

Table 5-5 PgA0 characteristics

Parameter	Symbol	Condition	Ratings			Unit
			Min	Typ	Max	
High level input voltage	VIH	CMOS	$0.7 \cdot \text{AnVDD}$	-	$\text{AnVDD} + 0.3$	V
Low level input voltage	VIL	CMOS	-0.5	-	$0.3 \cdot \text{AnVDD}$	V
High level output voltage	VOH	IOH = -1mA	$\text{AnVDD} - 1.0$	-	-	V
		IOH = -100 μ A	$\text{AnVDD} - 0.5$	-	-	
Low level output voltage	VOL	IOL = 1mA	-	-	0.4	V
		IOL = 100 μ A	-	-	0.4	
High level port output current	IOH	Power supply of PgA0	-	-	-20	mA
Low level port output current	IOL	Power supply of PgA0	-	-	20	mA
High level input leakage current	ILIH	VI = AnVDD	-	-	0.2	μ A
Low level input leakage current	ILIL	VI = 0V	-	-	-0.2	μ A
High level output leakage current	ILOH	VO = AnVDD	-	-	0.2	μ A
Low level output leakage current	ILOL	VO = 0V	-	-	-0.2	μ A
Output frequency	fO		-	-	25	MHz
Rise time (output)	tKRP		-	-	15	ns
Fall time (output)	tKFP		-	-	15	ns

Chapter 6 Supply current specification

6.1 Supply current of μ PDF70F4003 / μ PDF70F4004 / μ PDF70F4005 / μ PDF70F4006

Item	Power ^a		Condition ^b						Specification					Unit
	ISO0	ISO1	8MHz intOSC	Main OSC	Sub OSC	PLL	CPU Freq	Peripherals	Min.	Typ.	(A)	(A1)	(A2)	
RUN mode	ON	ON	ON	ON	ON	ON	80	WORKING	-	108	142	143	144	mA
	ON	ON	ON	ON	ON	ON	80	STOPPED	-	63	-	-	-	mA
	ON	ON	ON	OFF	ON	OFF	8	WORKING	-	22	40	41	41	mA
	ON	ON	ON	OFF	ON	OFF	8	STOPPED	-	17	-	-	-	mA
	ON	OFF	ON	ON	ON	ON	80	WORKING	-	87	117	118	119	mA
	ON	OFF	ON	ON	ON	ON	80	STOPPED	-	62	-	-	-	mA
	ON	OFF	ON	OFF	ON	OFF	8	WORKING	-	19	37	38	38	mA
	ON	OFF	ON	OFF	ON	OFF	8	STOPPED	-	17	-	-	-	mA
HALT mode	ON	ON	ON	ON	ON	ON	80	WORKING	-	102	136	137	138	mA
	ON	ON	ON	ON	ON	ON	80	STOPPED	-	61	-	-	-	mA
	ON	ON	ON	OFF	ON	OFF	8	WORKING	-	21	40	40	40	mA
	ON	ON	ON	OFF	ON	OFF	8	STOPPED	-	17	-	-	-	mA
STOP mode	ON	ON	OFF	OFF	OFF	OFF	-	STOPPED	-	0.7	19	20	22	mA
	ON	OFF	OFF	OFF	OFF	OFF	-	STOPPED	-	0.6	19	19	21	mA
DEEPSTOP mode	OFF	OFF	OFF	OFF	OFF	OFF	-	STOPPED	-	0.06	0.86	0.88	1.1	mA
	OFF	OFF	ON	OFF	OFF	OFF	-	STOPPED	-	0.60	2.1	2.3	2.5	mA
	OFF	OFF	ON	OFF	ON	OFF	-	STOPPED	-	0.60	2.1	2.3	2.5	mA

a) The AWO is always ON.

b) The 240kHz IntOSC is always ON.

- Notes**
- The above currents do not include port buffer currents or ADC currents.
 - The currents in run mode include currents for self-programming and EEPROM emulation.
 - The current of FlexRay is not included in case of CPU frequency = 8MHz.
 - The 'typical' specification is for reference only and not a guaranteed value. The 'typical' specification is applicable under the following conditions:
 - Ta = 25°C
 - REGnVDD=FVDD=OSCVDD=EmVDD=B0VDD=AmVDD=AmVREFP=5.0V (n=0-3, m=0-1).
 - M2 products: CVDD = 1.2V
 - REGnVSS=OSCVSS=EmVSS=B0VSS=AmVSS=AmVREFM=0V (n=0-3, m=0-1)

6.2 Supply current of μ PDF70F3551 / μ PDF70F3552 / μ PDF70F3553 / μ PDF70F3554

Item	Power ^a		Condition ^b						Specification					Unit
	ISO0	ISO1	8MHz intOSC	Main OSC	Sub OSC	PLL	CPU Freq	Peripherals	Min.	Typ.	(A)	(A1)	(A2)	
RUN mode	ON	ON	ON	ON	ON	ON	80	WORKING	-	92	123	124	125	mA
	ON	ON	ON	ON	ON	ON	80	STOPPED	-	60	-	-	-	mA
	ON	ON	ON	OFF	ON	OFF	8	WORKING	-	22	40	41	41	mA
	ON	ON	ON	OFF	ON	OFF	8	STOPPED	-	17	-	-	-	mA
	ON	OFF	ON	ON	ON	ON	80	WORKING	-	77	106	106	107	mA
	ON	OFF	ON	ON	ON	ON	80	STOPPED	-	59	-	-	-	mA
	ON	OFF	ON	OFF	ON	OFF	8	WORKING	-	19	37	38	38	mA
	ON	OFF	ON	OFF	ON	OFF	8	STOPPED	-	17	-	-	-	mA
HALT mode	ON	ON	ON	ON	ON	ON	80	WORKING	-	86	117	118	119	mA
	ON	ON	ON	ON	ON	ON	80	STOPPED	-	58	-	-	-	mA
	ON	ON	ON	OFF	ON	OFF	8	WORKING	-	21	40	40	40	mA
	ON	ON	ON	OFF	ON	OFF	8	STOPPED	-	17	-	-	-	mA
STOP mode	ON	ON	OFF	OFF	OFF	OFF	-	STOPPED	-	0.7	19	20	22	mA
	ON	OFF	OFF	OFF	OFF	OFF	-	STOPPED	-	0.6	19	19	21	mA
DEEPSTOP mode	OFF	OFF	OFF	OFF	OFF	OFF	-	STOPPED	-	0.06	0.86	0.88	1.1	mA
	OFF	OFF	ON	OFF	OFF	OFF	-	STOPPED	-	0.60	2.1	2.3	2.5	mA
	OFF	OFF	ON	OFF	ON	OFF	-	STOPPED	-	0.60	2.1	2.3	2.5	mA

a) The AWO is always ON.

b) The 240kHz IntOSC is always ON.

- Notes**
1. The above currents do not include port buffer currents or ADC currents.
 2. The currents in run mode include currents for self-programming and EEPROM emulation.
 3. The 'typical' specification is for reference only and not a guaranteed value. The 'typical' specification is applicable under the following conditions:
 - Ta = 25°C
 - REGnVDD=FVDD=OSCVDD=EmVDD=B0VDD=AmVDD=AmVREFP=5.0V (n=0-3, m=0-1).
 - M2 products: CVDD = 1.2V

REGnVSS=OSCVSS=EmVSS=B0VSS=AmVSS=AmVREFM=0V
(n=0-3, m=0-1)

6.3 Voltage Comparator characteristics

Table 6-1 VCMP characteristics

Parameter	Symbol	Condition	Ratings			Unit
			Min	Typ	Max	
VCMP current	IVCMP		-	200	300	μ A

Chapter 7 Peripherals specification

7.1 Reset timing

Parameter	Symbol	Condition	Ratings			Unit
			Min	Typ	Max	
RESET input High level width	tWRSH	Highspeed OSC is operating	450	-	-	ns
		Highspeed OSC is stopped	4.7	-	-	μs
RESET input Low level width	tWRSL	Highspeed OSC is operating	450	-	-	ns
		Highspeed OSC is stopped	4.7	-	-	μs

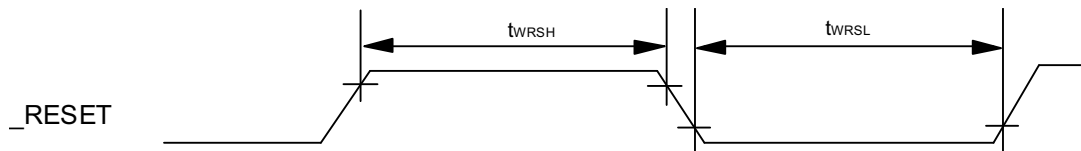

7.2 NMI timing

Parameter	Symbol	Condition	Ratings			Unit
			Min	Typ	Max	
NMI input High level width	tWNIH		300	-	-	ns
NMI input Low level width	tWNIL		300	-	-	ns

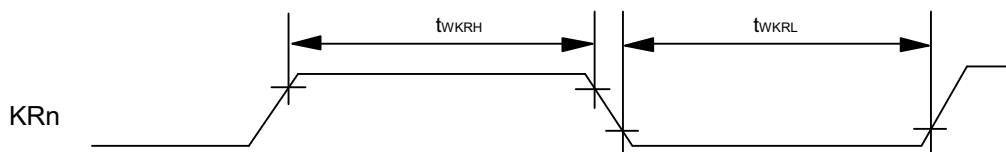

7.3 INTP timing

Parameter	Symbol	Condition	Ratings			Unit
			Min	Typ	Max	
INTPn input High level width	t _{WITH}		300	-	-	ns
INTPn input Low level width	t _{WITL}		300	-	-	ns

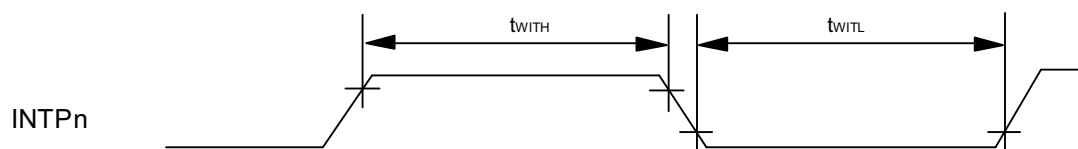

7.4 FLMD0 timing

Parameter	Symbol	Condition	Ratings			Unit
			Min	Typ	Max	
FLMD0 input High level width	t _{WMDH}		300	-	-	ns
FLMD0 input Low level width	t _{WMDL}		300	-	-	ns
FLMD0 external pull down resistor	R _{FLMD0}		82	-	-	kΩ



7.5 _DCUTRST timing

Parameter	Symbol	Condition	Ratings			Unit
			Min	Typ	Max	
_DCUTRST input High level width	t _{WRH}		450	-	-	ns
_DCUTRST input Low level width	t _{WTRL}		450	-	-	ns

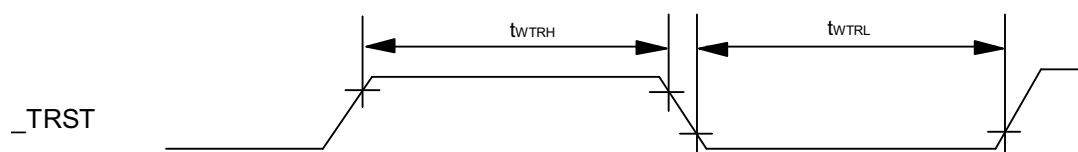

7.6 Timer timing

Table 7-1 Timer timing

Parameter	Symbol	Condition	Ratings			Unit
			Min	Typ	Max	
TAUAnI input High level width	tTAIH	n=0	a,b	-	-	ns
TAUAnI input Low level width	tTAIL	n=0	a,b	-	-	ns
TAUBnI input High level width	tTBIH	n=1	a,b	-	-	ns
TAUBnI input Low level width	tTBIL	n=0	a,b	-	-	ns
TAUJnI input High level width	tTJIH	n=0,1	300	-	-	ns
TAUJnI input High level width	tTJIH		4.7	-	-	μs
TAUJnI input High level width	tTJIH		b	-	-	ns
TAUJnI input Low level width	tTJIL	n=0,1	300	-	-	ns
TAUJnI input Low level width	tTJIL		4.7	-	-	μs
TAUJnI input Low level width	tTJIL		b	-	-	ns
TAUAnO output cycle	tTACYK	n=0	-	-	20	MHz
TAUBnO output cycle	tTBCYK	n=1	-	-	20	MHz
TAUCnO output cycle	tTCCYK	n=2-7	-	-	20	MHz
TAUJnO output cycle	tTJCYK	n=0,1	-	-	20	MHz
TAPAnESO input High level width	tWESH	n=0	300	-	-	ns
TAPAnESO input Low level width	tWESL	n=0	300	-	-	ns
ENCAnTmIN high level width	tWENmH	n=0, m=A,B,Z	a,b	-	-	ns
ENCAnTmIN low level width	tWENmL	n=0, m=A,B,Z	a,b	-	-	ns
ENCAnTINm high level width	tWENmH	n=0, m=0-1	a,b	-	-	ns
ENCAnTINm low level width	tWENmL	n=0, m=0-1	a,b	-	-	ns

- a) With digital noise filter enabled: $2, 3, 4$ or $5 \times T_{\text{samp}} + 20$ (T_{samp} shows sampling period specified in Noise filter macro. More than 1 PCLK width of Timer macro must be kept regarding DNF pass through pulse width.)
- b) With digital noise filter disabled: $1 \times t_{\text{SYNC}} + 20$ (t_{SYNC} : 1 PCLK of Timer macro)

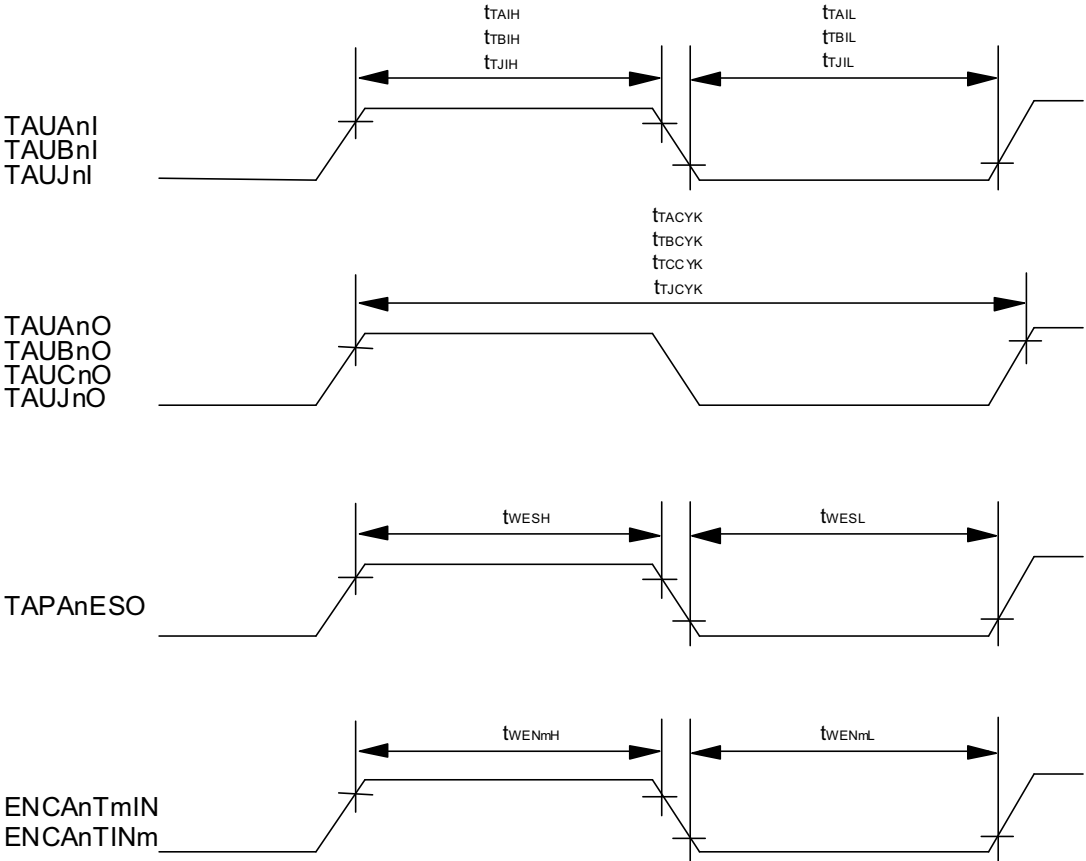

7.7 CSI timing

7.7.1 Master modes

(1) CSIG timing

Table 7-2 CSIG timing (Master mode)

Parameter	Symbol	Condition	Ratings			Unit
			Min	Typ	Max	
Macro Operation clock cycle time	tKCYGn		20.8	-	-	ns
CSIGnSC cycle time	tKCYMGn		100	-	-	ns
CSIGnSC high level width	tKWHMGn		$0.5 \cdot tKCYMGn - 10$	-	-	ns
CSIGnSC low level width	tKWLMGn		$0.5 \cdot tKCYMGn - 10$	-	-	ns
CSIGnSI setup time (vs. CSIGnSC)	tSSIMGn	CSIGnSC@PDSC=1	30	-	-	ns
CSIGnSI setup time (vs. CSIGnSC)	tSSIMGn	CSIGnSC@PDSC=0	38	-	-	ns
CSIGnSI hold time (vs. CSIGnSC)	tHSIMGn		0	-	-	ns
CSIGnSO output delay (vs. CSIGnSC)	tDSOMGn		-	-	7	ns
CSIGnRYI setup time (vs. CSIGnSC)	tSRYIGn	CSIGnCTL1.CSIGnSIT=x CSIGnCTL1.CSIGnHSE=1	$2 \cdot tKCYGn + 25$	-	-	ns
CSIGnRYI High level width	tWRYIGn	CSIGnCTL1.CSIGnHSE=1	$tKCYGn - 5.0$	-	-	ns

Note n: Number of macro instances. Refer to the User Manual for the detailed specification.

(2) CSIH timing master mode

Table 7-3 CSIH timing (Master mode)

Parameter	Symbol	Condition	Ratings			Unit
			Min	Typ	Max	
Macro Operation clock cycle time	tKCYHn		20.8	-	-	ns
CSIHnSC cycle time	tKCYMHn		100	-	-	ns
CSIHnSC high level width	tKWHMHn		$0.5 \cdot tKCYMHn - 10$	-	-	ns
CSIHnSC low level width	tKWLMHn		$0.5 \cdot tKCYMHn - 10$	-	-	ns
CSIHnSI setup time (vs. CSIHnSC)	tSSIMHn	CSIHnSC@PDSC=1	30	-	-	ns
		CSIHnSC@PDSC=0	38	-	-	ns
CSIHnSI hold time (vs. CSIHnSC)	tHSIMHn		0	-	-	ns
CSIHnSO output delay (vs. CSIHnSC)	tDSOMHn		-	-	7	ns
CSIHnRYI setup time (vs. CSIHnSC)	tSRYIHn	CSIHnCTL1.CSIHnSIT=x CSIHnCTL1.CSIHnHSE=1	$2 \cdot tKCYHn + 25$	-	-	ns
CSIHnRYI High level width	tWRYIHn	CSIHnCTL1.CSIHnHSE=1	$tKCYHn - 5.0$	-	-	ns
CSIHnCSS0-7 inactive width	tWSCSBHn		$CSIDLE \times tKCYMHn - 5.0$	-	-	ns
CSIHnCSS0-7 setup time (vs. CSIHnSC)	tSSCSBHn0	CSIHnCTL1.CSIHnDAP=0	$CSSETUP \times tKCYMHn - 5.0$	-	-	ns
	tSSCSBHn1	CSIHnCTL1.CSIHnDAP=1	$(CSSETUP + 0.5) \times tKCYMHn - 5.0$	-	-	ns
CSIHnCSS0-7 hold time (vs. CSIHnSC)	tHSCSBHn0	CSIHnCTL1.CSIHnSIT=0	$CSHOLD \times tKCYMHn - 10.0$	-	-	ns
	tHSCSBHn1	CSIHnCTL1.CSIHnSIT=1	$(CSSHOLD + 0.5) \times tKCYMHn - 5.0$	-	-	ns

- Notes**
1. n: Number of macro instances. Refer to the User Manual for the detailed specification.
 2. CSSETUP: Value of CSIHnCFG0-7.CSIHnSP0-7[3:0]
 3. CSHOLD: Value of CSIHnCFG0-7.CSIHnHD0-7[3:0]
 4. CSIDLE: Value of CSIHnCFG0-7.CSIHnID0-7[2:0]

(3) Timing diagrams

SCKO / SI / SO

CSIG (CSIGnCTL1 : CSIGnCKR/ CSIGnCFG0 :CHIGnDAP0 = 0 / 0 or 1 / 1)
 CSIH (CSIHnCFGm:CSIHnCKPm/ CSIHnCFGm: CHIHnDAPm= 0 / 0 or 1 / 1)

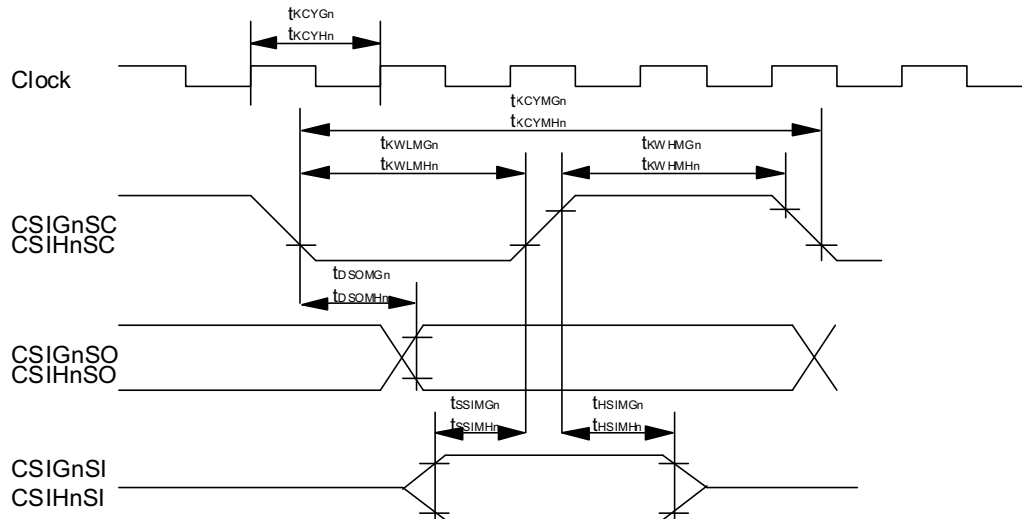

CSIG(CSIGnCTL1 : CSIGnCKR/ CSIGnCFG0 :CHIGnDAP0 = 1 / 0 or 0 / 1)
 CSIH (CSIHnCFGm:CSIHnCKPm/ CSIHnCFGm: CHIHnDAPm= 1 / 0 or 0 / 1)

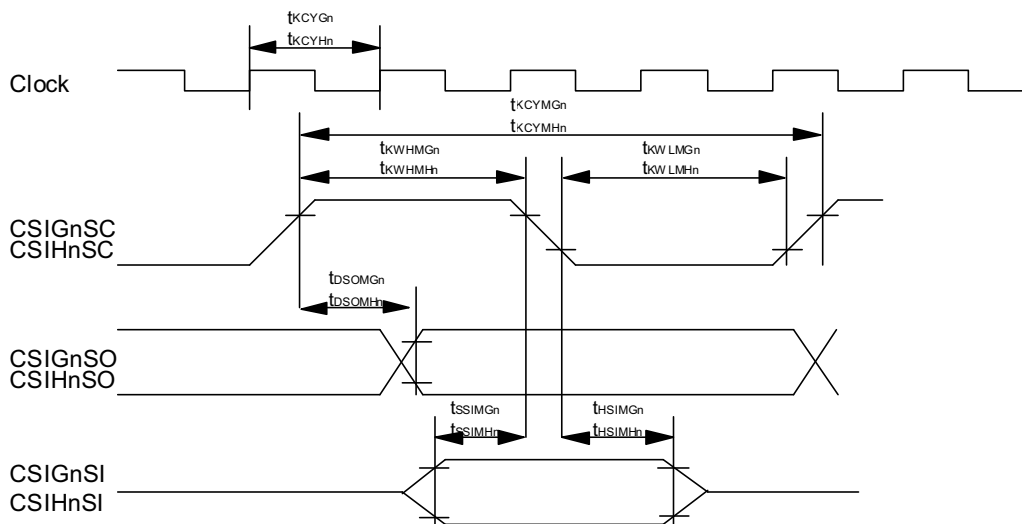

RYI

CSIGnCTL1 : CSIGnHSE=1, CSIGnCTL1 : CSIGnSIT = 0)
 CSIHnCTL1 : CSIHnHSE=1, CSIHnCTL1 : CSIHnSIT = 0)

CSIG (CSIGnCTL1 :CSIGnCKR= 0)
 CSIH (CSIHnCFGm:CSIHnCKPm= 0)

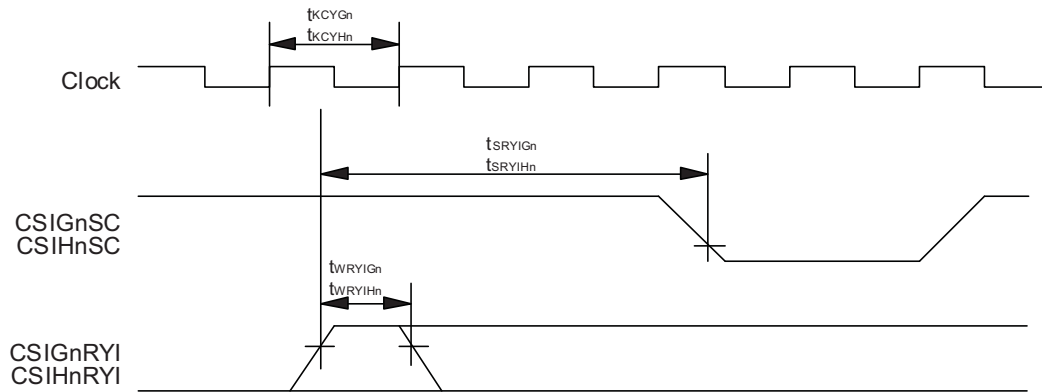

CSIG (CSIGnCTL1 :CSIGnCKR= 1)
 CSIH (CSIHnCFGm:CSIHnCKPm= 1)

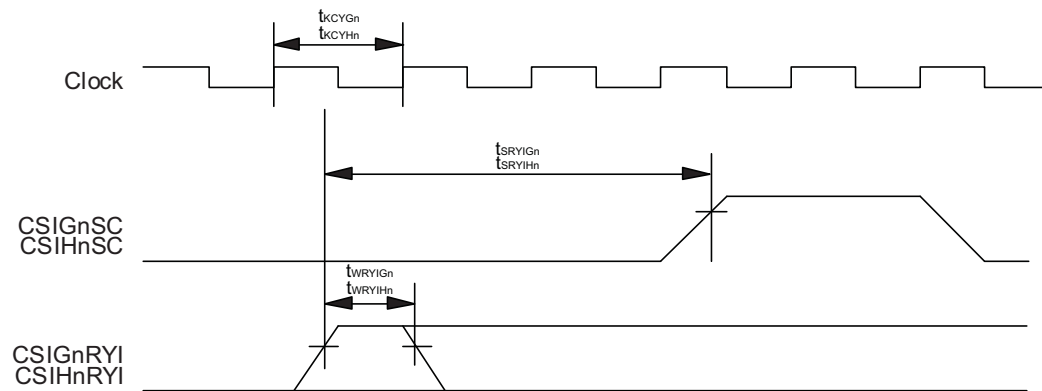

CSSn

CSIHnCFGm:CSIHnCKPm= 0,CSIHnCFGm:CHIHnDAPm= 0

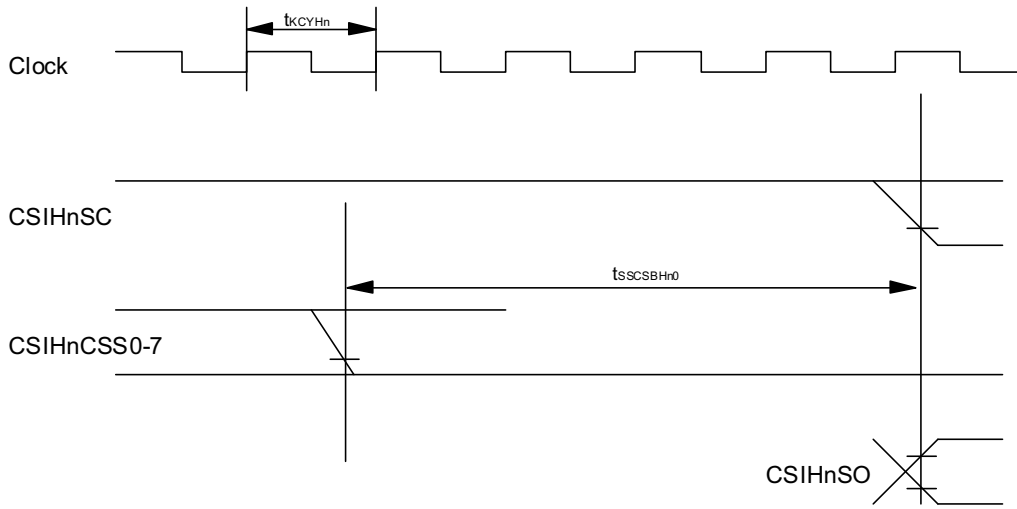

CSIHnCFGm:CSIHnCKPm= 0,CSIHnCFGm:CHIHnDAPm= 1

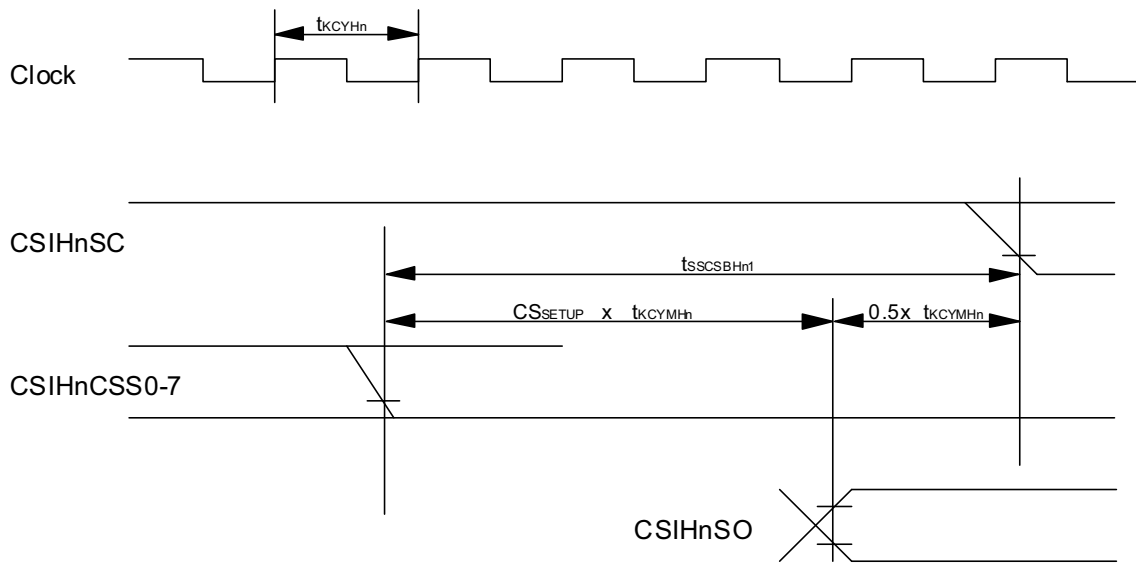

CSIHnCTL1 : CSIHnSIT=0, CSIHnCFGm: CSIHnCKPm= 0,CSIHnCFGm: CHIHnDAPm= 0

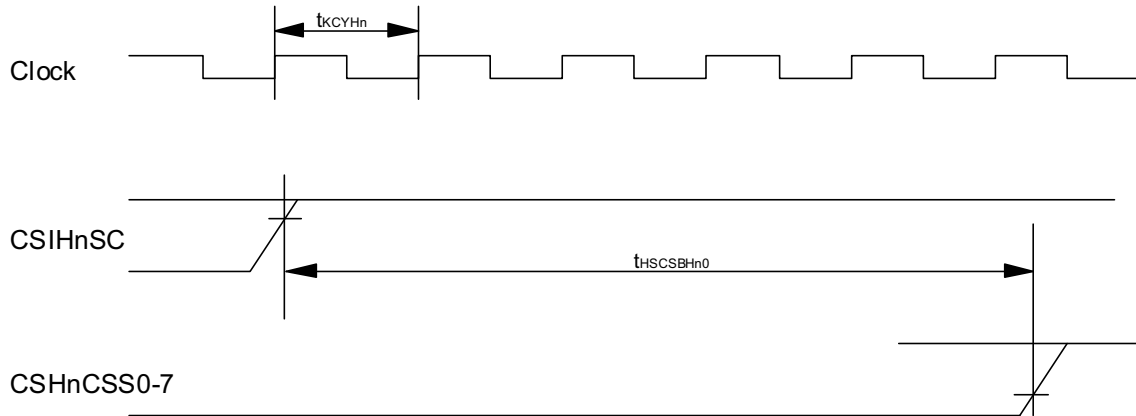

CSIHnCTL1 : CSIHnSIT=1, CSIHnCFGm: CSIHnCKPm= 0,CSIHnCFGm: CHIHnDAPm= 0

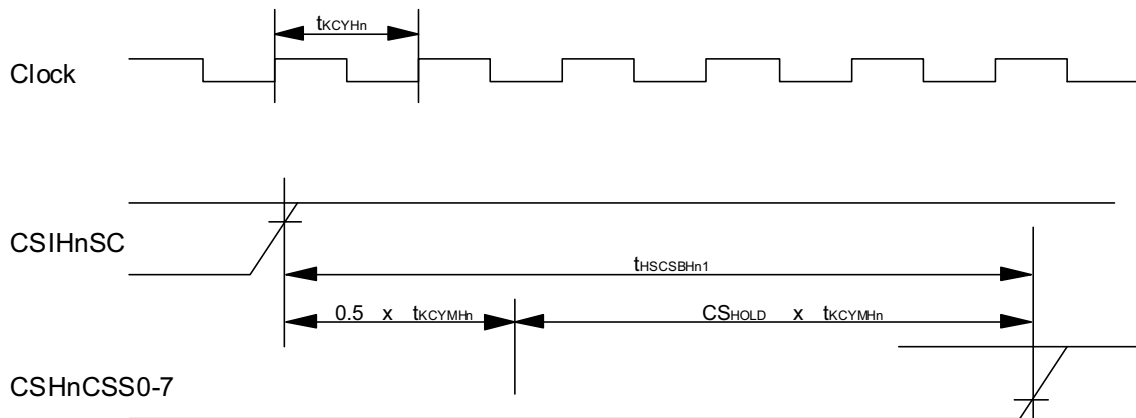

7.7.2 Slave mode

(1) CSIG timing slave mode

Table 7-4 CSIG timing (Slave mode)

Parameter	Symbol	Condition	Ratings			Unit
			Min	Typ	Max	
Macro Operation clock cycle time	tKCYGn		20.8	-	-	ns
CSIGnSC cycle time	tKCYSGn		200	-	-	ns
CSIGnSC high level width	tKWHSn		$0.5 \cdot tKCYSGn-10$	-	-	ns
CSIGnSC low level width	tKWLSn		$0.5 \cdot tKCYSGn-10$	-	-	ns
CSIGnSI setup time (vs. CSIGnSC)	tSSISn		20	-	-	ns
CSIGnSI hold time (vs. CSIGnSC)	tHSISn		$tKCYGn+5.0$	-	-	ns
SO output delay (vs SCKI)	tDSOSn		-	-	35	ns
CSIGnRYO output delay	tSRYOGn		-	-	35	ns
_CSIGnSSI setup time (vs CSIGnSC)	tSSSISn		$0.5 \cdot tKCYSn-5.0$	-	-	ns
_CSIGnSSI hold time (vs CSIGnSC)	tHSSISn		$tKCY+5.0$	-	-	ns

Note n: Number of macro instances. Refer to the User Manual for the detailed specification.

(2) CSIH timing slave mode

Table 7-5 CSIH timing (Slave mode)

Parameter	Symbol	Condition	Ratings			Unit
			Min	Typ	Max	
Macro Operation clock cycle time	tKCYHn		20.8	-	-	ns
CSIHnSC cycle time	tKCYSHn		200	-	-	ns
CSIHnSC high level width	tKWHSn		$0.5 \cdot tKCYSHn-10$	-	-	ns
CSIHnSC low level width	tKWLSn		$0.5 \cdot tKCYSHn-10$	-	-	ns
CSIHnSI setup time (vs. CSIHnSC)	tSSISHn		20	-	-	ns
CSIHnSI hold time (vs. CSIHnSC)	tHSISHn		$tKCYHn+5.0$	-	-	ns
SO output delay (vs SCKI)	tDSOSHn		-	-	35	ns
CSIHnRYO output delay	tSRYOHn		-	-	35	ns
CSIHnSSI setup time (vs. CSIHnSC)	tSSSISHn		$0.5 \cdot tKCYSn-5.0$	-	-	ns
CSIHnSSI hold time (vs. CSIHnSC)	tHSSISHn		$tKCYn* 5.0$	-	-	ns

Note n: Number of macro instances. Refer to the User Manual for the detailed specification.

(3) Timing diagrams

SCKO / SI / SO

CSIG (CSIGnCTL1 : CSIGnCKR/ CSIGnCFG0 :CHIGnDAP0 = 0/0 or 1/1)
 CSIH (CSIHnCFGm:CSIHnCKPm/ CSIHnCFGm: CHIHnDAPm= 0/0 or 1/1)

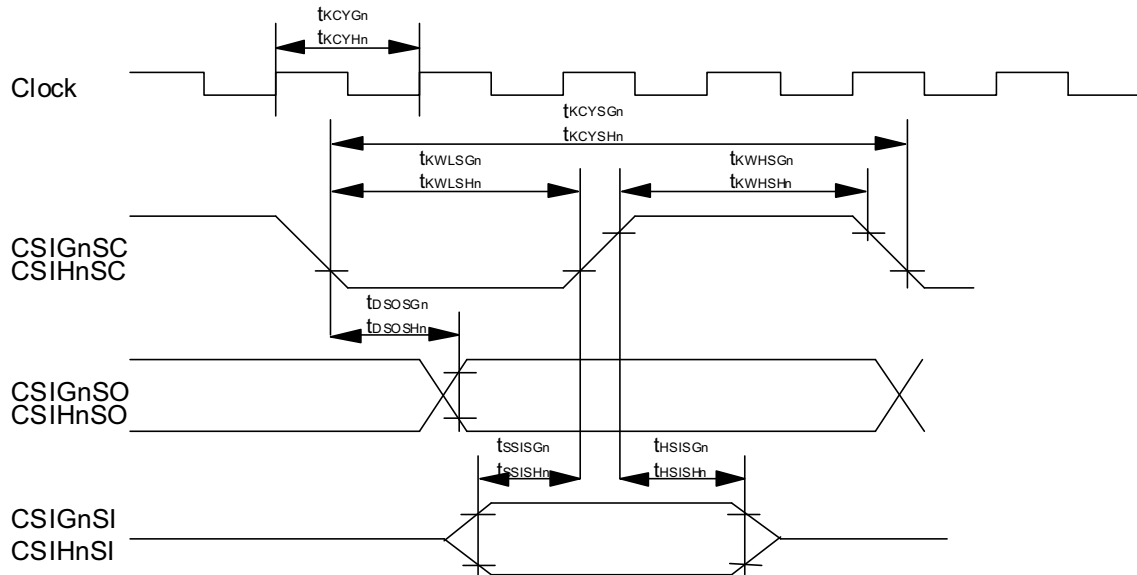

CSIG (CSIGnCTL1 : CSIGnCKR/ CSIGnCFG0 :CHIGnDAP0 = 1/0 or 0/1)
 CSIH (CSIHnCFGm:CSIHnCKPm/ CSIHnCFGm: CHIHnDAPm= 1/0 or 0/1)

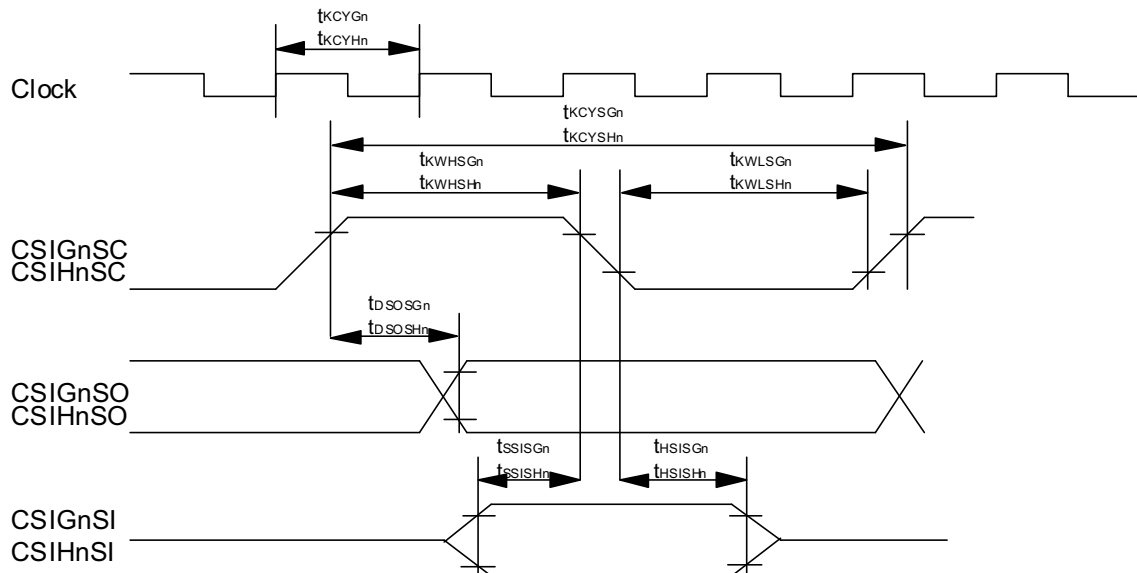

RYO

CSIG (CSIGnCTL1 : CSIGnCKR/ CSIGnCFG0 :CHIGnDAP0 = 0/0)
 CSIH (CSIHnCFGm:CSIHnCKPm/ CSIHnCFGm: CHIHnDAPm= 0/0)

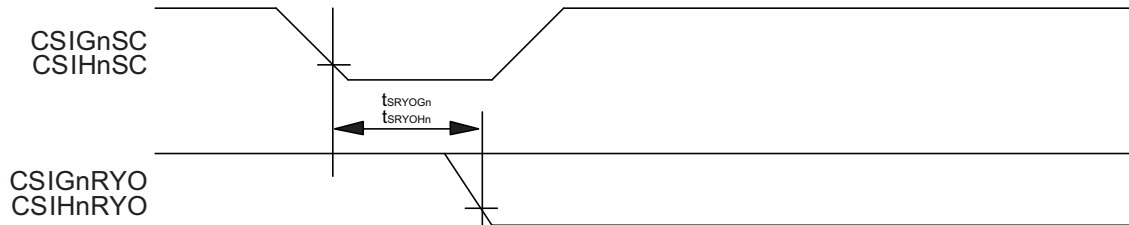

CSIG (CSIGnCTL1 : CSIGnCKR/ CSIGnCFG0 :CHIGnDAP0 = 0/1)
 CSIH (CSIHnCFGm:CSIHnCKPm/ CSIHnCFGm: CHIHnDAPm= 0/1)

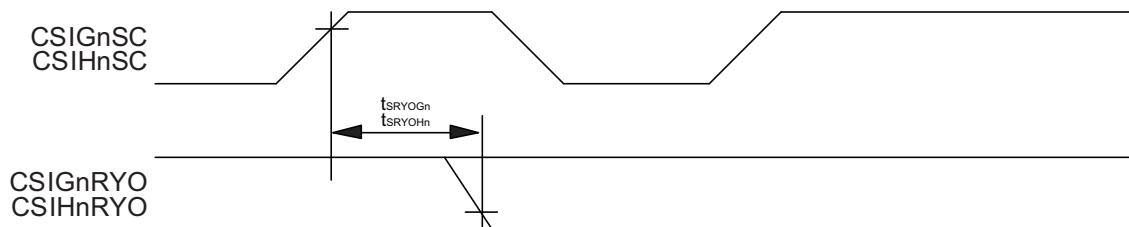

CSIG (CSIGnCTL1 : CSIGnCKR/ CSIGnCFG0 :CHIGnDAP0 = 1/0)
 CSIH (CSIHnCFGm:CSIHnCKPm/ CSIHnCFGm: CHIHnDAPm= 1/0)

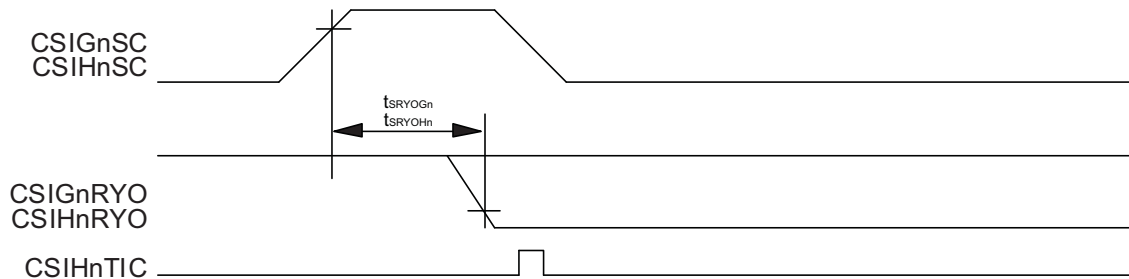

CSIG (CSIGnCTL1 : CSIGnCKR/ CSIGnCFG0 :CHIGnDAP0 = 1/1)
 CSIH (CSIHnCFGm:CSIHnCKPm/ CSIHnCFGm: CHIHnDAPm= 1/1)

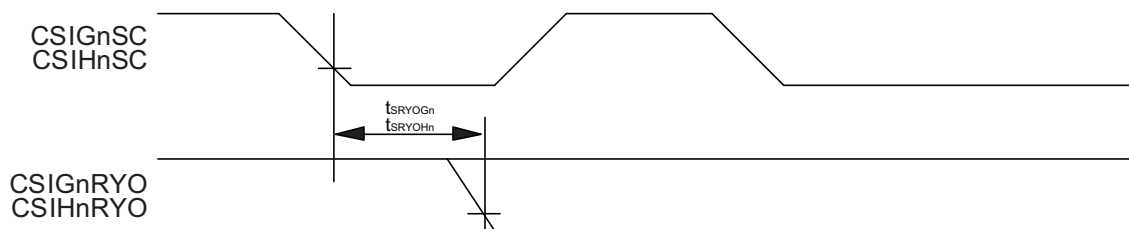

SSI:

CSIG (CSIGnCTL1 :CSIGnSSE=1, CSIGnCTL1 : CSIGnCKR,/ CSIGnCFG0 : CHIGnDAP0 = 0/0 or 1/1)

CSIH (CSIHnCTL1 : CSIHnSSE=1, CSIHnCFGm : CSIHnCKPm / CSIHnCFGm : CHIHnDAPm = 0/0 or 1/1)

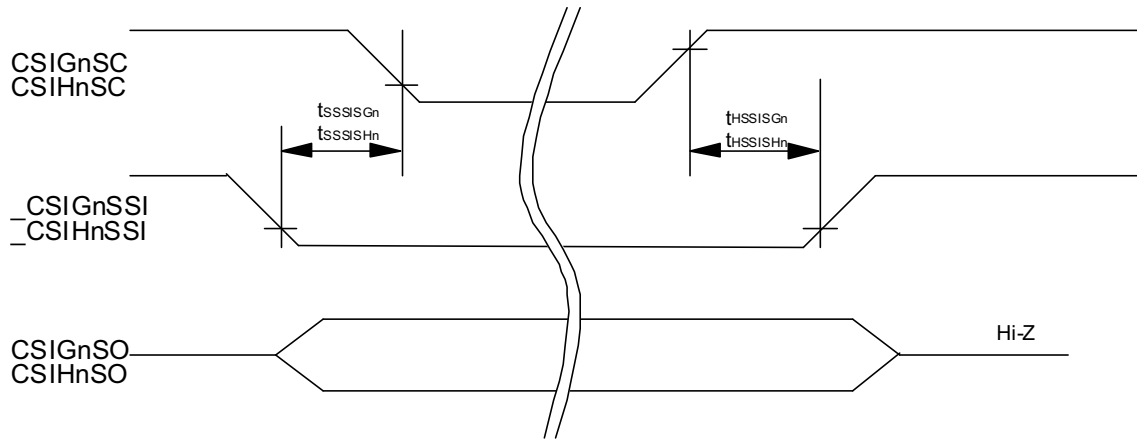

CSIG (CSIGnCTL1 :CSIGnSSE=1, CSIGnCTL1 : CSIGnCKR,/ CSIGnCFG0 : CHIGnDAP0 = 1/0 or 0/1) n=0, 4

CSIH (CSIHnCTL1 : CSIHnSSE=1, CSIHnCFGm : CSIHnCKPm / CSIHnCFGm : CHIHnDAPm = 1/0 or 0/1)

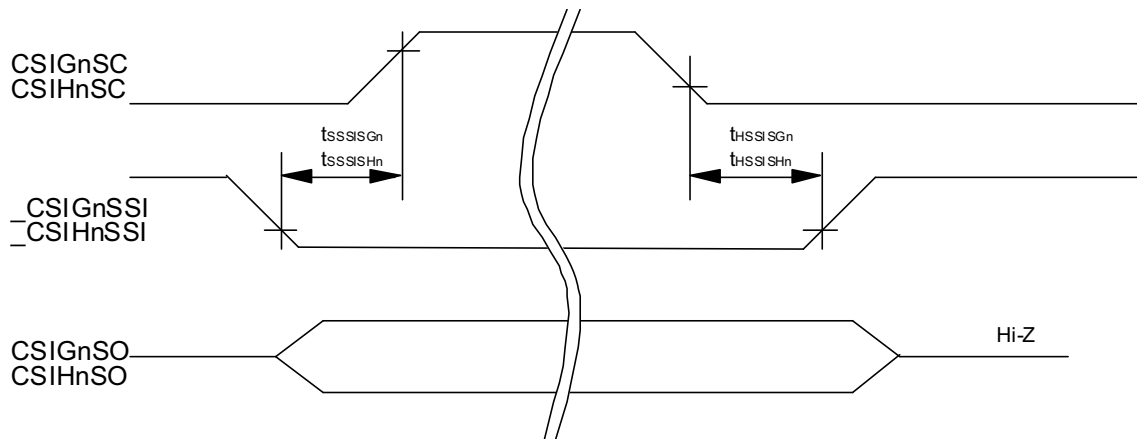

7.8 UART timing

Parameter	Symbol	Condition	Ratings			Unit
			Min	Typ	Max	
Transfer rate			-	-	1.5	Mbps

7.9 FCN timing

Parameter	Symbol	Condition	Ratings			Unit
			Min	Typ	Max	
Transfer rate			-	-	1	Mbps
Internal delay time	t _{INTDEL}		-	-	37.5	ns
CAN Node delay time	t _{NODE}	t _{CYCLE} = 62.5ns	-	-	100	ns

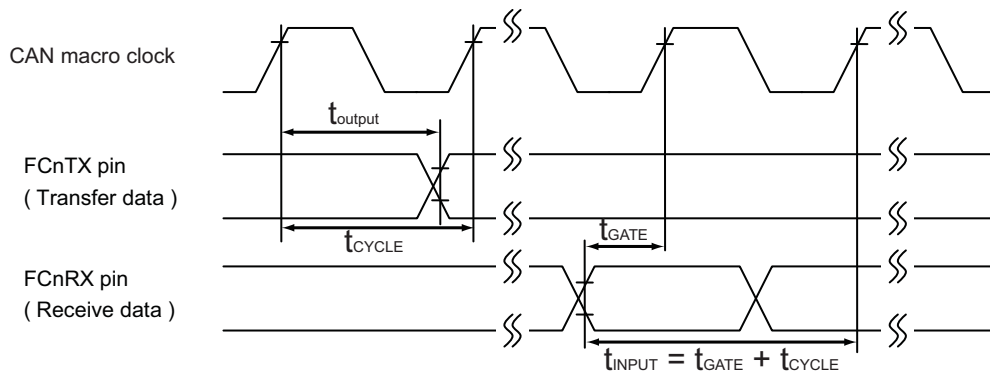

CAN node delay time (t_{NODE}) = INPUT delay time (t_{input}) + Output delay time (t_{output})
 Internal delay time (t_{INTDEL}) = Internal gate delay time (t_{GATE}) + Output delay time (t_{output})

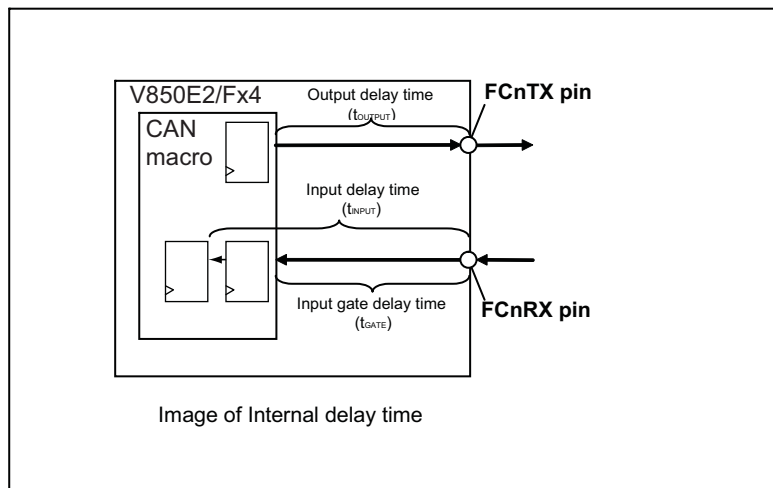

7.10 FlexRay timing

Parameter	Symbol	Condition	Ratings			Unit
			Min	Typ	Max	
Transfer rate			-	-	10	Mbps
Node Output Delay	t _{OUTPUT}	FLX0TXDA, FLX0TXDB,	-	-	25	ns
		FLX0TXENA, FLX0TXENB	-	-		
Node Input Delay	t _{INPUT}	FLX0RXDA, FLX0RXDB	-	-	10	ns

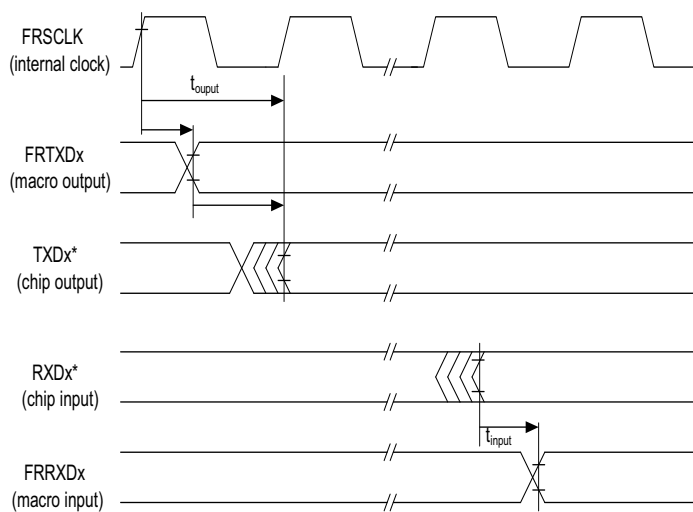
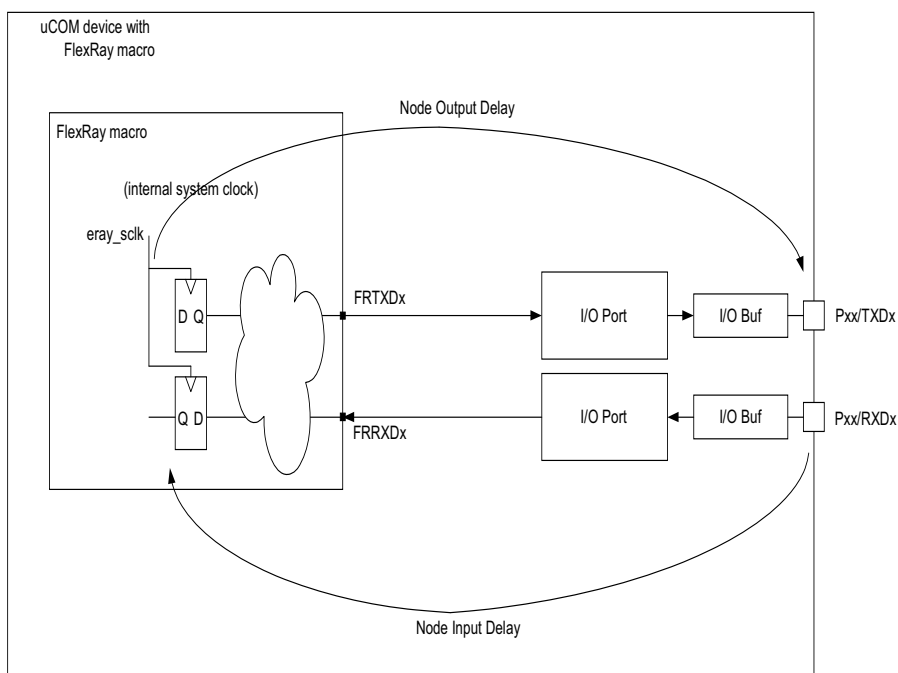

Port	Name	Condition	Ratings			Unit
			Min	Typ	Max	
FLX0TXENA FLX0TXENB	dTxEN _{RISE-FALL}	Clod=25pF, measured at 20-80% E1VDD	-	-	9	ns
	dCCTxEN01		-	-	25	ns
	dCCTxEN10		-	-	25	ns
FLX0TXDA FLX0TXDB	dCCTxAsym	measured at 50% E1VDD	-	-	2.45	ns
	dCCTxDRISE25 + dCCTxDFALL25	Clod=25pF, measured at 20-80% E1VDD	-	-	9	ns
		Clod=10pF, measured at 20-80% E1VDD at the end of a 50ohm, 1ns microstripline	-	-	9	ns
	dCCTxD01	-	-	-	25	ns
dCCTxD10	-	-	-	25	ns	
FLX0RXDA FLX0RXDB	dCCRxAsmAccept	measured at 50% of E1VDD Input signal: Clod=25pF, 6.5ns (20-80% E1VDD)	-	-	5.5	ns
	C_CCRxD	-	-	-	10	pf
	uLogic_1	-	35	-	70	%
	uLogic_0	-	30	-	65	%
	dCCRxD01	-	-	-	10	ns
	dCCRxD10	-	-	-	10	ns

7.11 IIC timing

Table 7-6 Normal mode

Parameter	Symbol	Condition	Ratings			Unit
			Min	Typ	Max	
SCL clock period	fCLK		0		100	kHz
Bus free time (between stop condition and start condition)	tBUF		4.7	-	-	μs
Start/Restart Hold time (New clock pulse is generated after this hold time as a master.)	tHD:STA		4	-	-	μs
SCL clock low state hold time	tLOW		4.7	-	-	μs
SCL clock high state hold time	tHIGH		4	-	-	μs
Setup time for start/restart condition	tSU:STA		4.7	-	-	μs
Data hold time	tHD:DAT	CBUS compatible	5	-	-	μs
		IIC bus	0	-	-	μs
Data setup time	tSU:DAT		250	-	-	ns
Rising transition time of SDA or SCL	tR		-	-	1000	ns
Falling transition time of SDA or SCL	tF		-	-	300	ns
Setup time of stop condition	tSU:STO		4	-	-	μs
Bus capacitance	Cb		-	-	400	pF

Table 7-7 Fast mode

Parameter	Symbol	Condition	Ratings			Unit
			Min	Typ	Max	
SCL clock period	fCLK		0	-	400	kHz
Bus free time (between stop condition and start condition)	t _{BUF}		1.3	-	-	μs
Start/Restart Hold time (New clock pulse is generated after this hold time as a master.)	t _{HD:STA}		0.6	-	-	μs
SCL clock low state hold time	t _{LOW}		1.3	-	-	μs
SCL clock high state hold time	t _{HIGH}		0.6	-	-	μs
Setup time for start/restart condition	t _{SU:STA}		0.6	-	-	μs
Data hold time	t _{HD:DAT}	IIC bus	0	-	0.9	μs
Data setup time	t _{SU:DAT}		100	-	-	ns
Rising transition time of SDA or SCL	t _R		20+0.1Cb	-	300	ns
Falling transition time of SDA or SCL	t _F		20+0.1Cb	-	300	ns
Setup time of stop condition	t _{SU:STO}		0.6	-	-	μs
Noise elimination width	t _{SP}		0	-	50	ns
Bus capacitance	Cb		-	-	400	pF

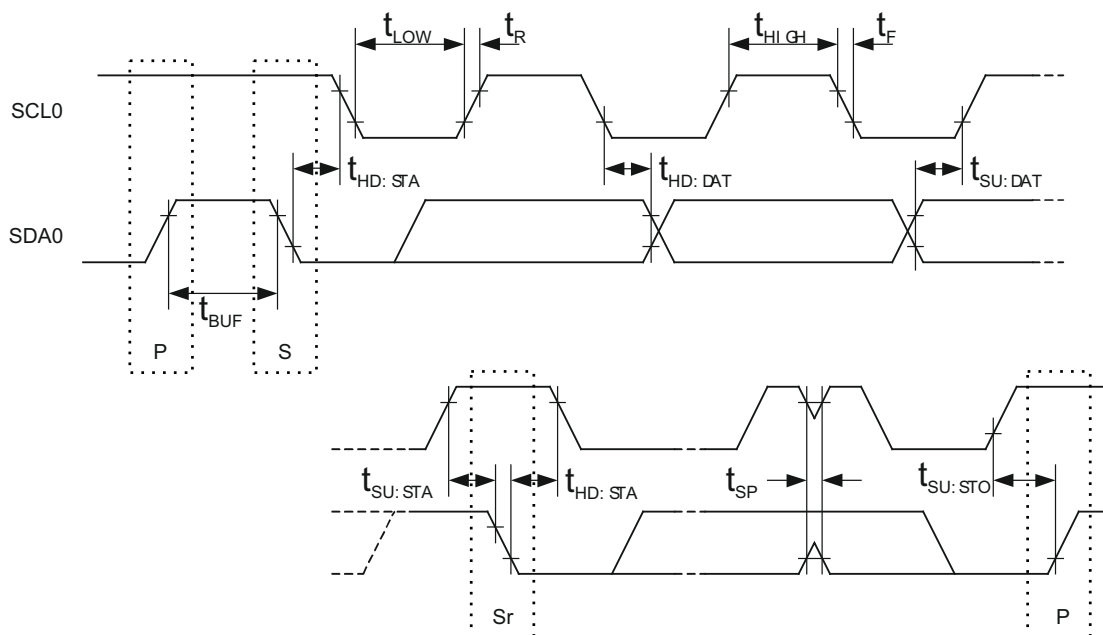

Notes 1. P: Stop condition

Notes 1. S: Start condition

Notes 1. Sr: Restart condition

7.12 Frequency Output Function (FOUT)

Table 7-8 Frequency Output Function (FOUT)

Parameter	Symbol	Condition	Ratings			Unit
			Min	Typ	Max	
CSCXFOUTP output cycle	tFO		50	-	-	ns
CSCXFOUTP high level width	tWKHFO		tFO / 2 - 10	-	-	ns
CSCXFOUTP low level width	tWKLFO		tFO / 2 - 10	-	-	ns
CSCXFOUTP rise time	tKRFO		-	-	10	ns
CSCXFOUTP fall time	tKFFO		-	-	10	ns

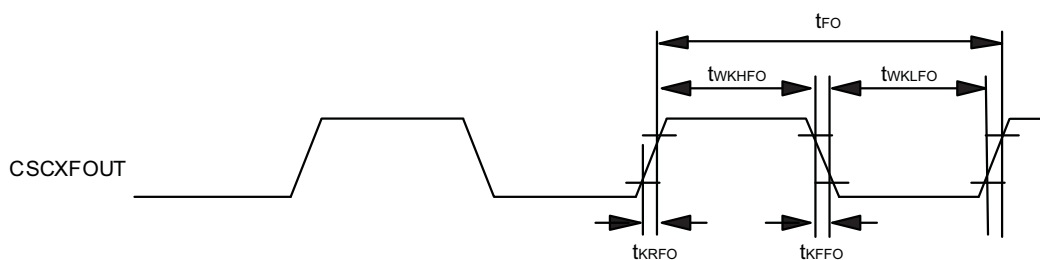

7.13 VLVI characteristics

Table 7-9 VLVI characteristics

Parameter	Symbol	Condition	Ratings			Unit
			Min	Typ	Max	
Detection voltage	VRAMHF		1.8	1.9	2.0	V
Voltage slope1	Rvs1		0.18	-	1800	V/ms
Voltage slope2	Rvs2		0.0018	-	1800	V/ms
Response time ^a	tRAMHD		-	-	2	ms

^a) From detection voltage to setting of VLVI bit (VLVI.bit0)

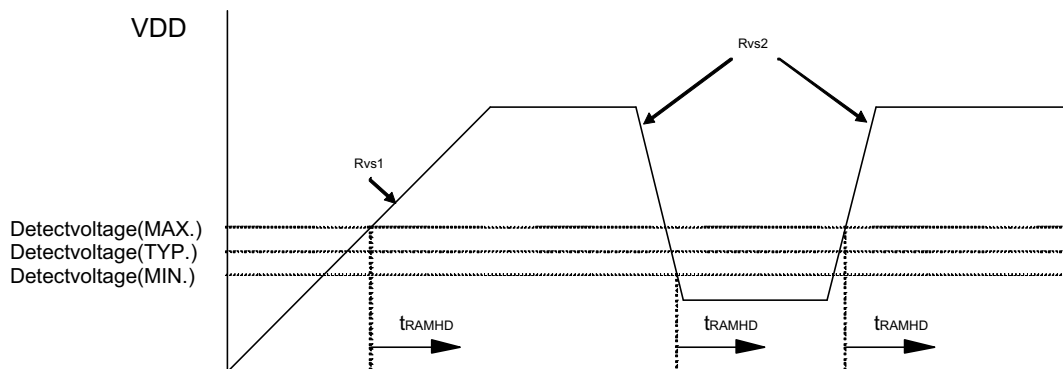

Note VDD: REG0VDD

7.14 Voltage comparator characteristics

Parameter	Symbol	Condition	Ratings			Unit
			Min	Typ	Max	
VCMP current	IVCMP		-	200	300	μA
Threshold voltage (rise)	VCMPR		1.745	1.780	1.815	V
Threshold voltage (fall)	VCMPF		1.645	1.680	1.715	V
Voltage slope	VCVS		-	-	50	$\text{mV}/\mu\text{s}$
Detection time	tVCMPD		-	-	2	μs
Stabilization time	tVCMPST	VCMP operation readiness after VCPC0OEn is set to 1	-	-	2	ms

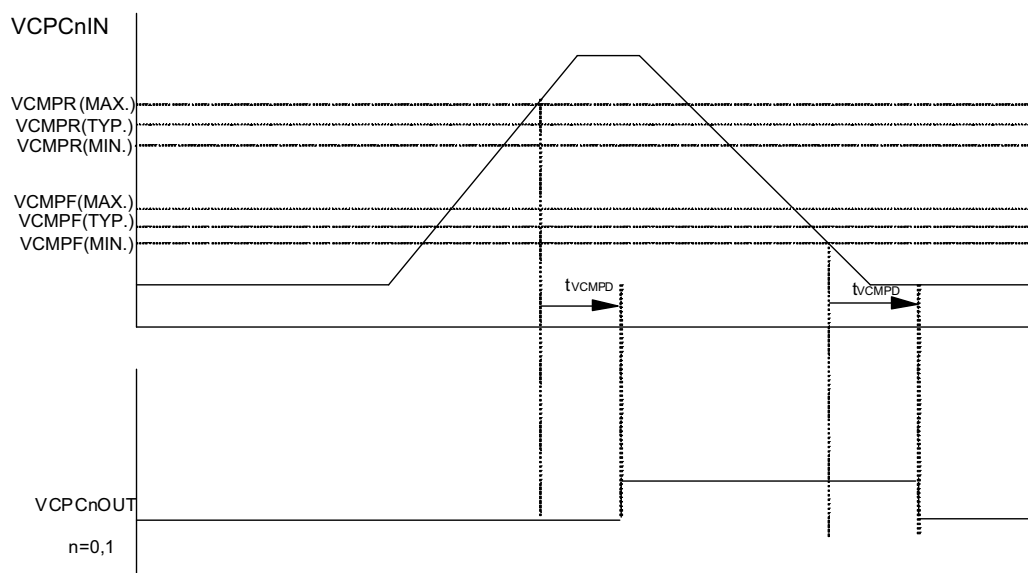

7.15 LVI characteristics

Table 7-10 LVI characteristics

Parameter	Symbol	Condition	Ratings			Unit
			Min	Typ	Max	
Detection voltage	VLVI0	LVICNT.LVICNT[2:0]=001 _B	3.9	4.0	4.1	V
	VLVI1	LVICNT.LVICNT[2:0]=010 _B	3.6	3.7	3.8	V
	VLVI2	LVICNT.LVICNT[2:0]=011 _B	3.4	3.5	3.6	V
Voltage slope1	LVS1		0.18	-	1800	V/ms
Voltage slope2	LVS2		0.0018	-	1800	V/ms
Response time	t _{LD}		-	-	2.0	ms
VDD minimum width	t _{LW}		2	-	-	ms
Stabilization time	t _{LVIST}	LVICNT0,1 is set to 1, then LVI is ready to operate	-	-	350	μs

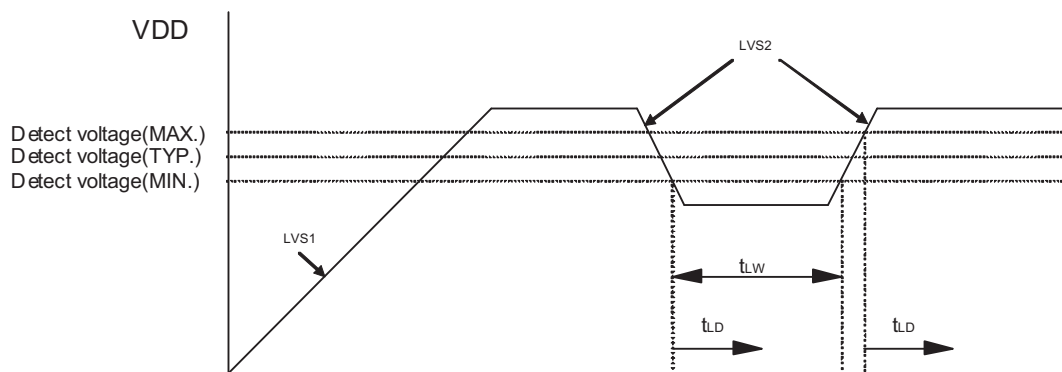

7.16 A/D Converter characteristics

7.16.1 12bit A/D (for ADC channels without S/H functionality)

Table 7-11 12bit A/D

Parameter	Symbol	Condition	Ratings			Unit
			Min	Typ	Max	
Resolution	RESn		12	12	12	bit
Total conversion time	TCONn		1.5	-	10	μs
Overall error ^a	TOEn		-	-	±6.0	LSB
Non-linearity error ^a	ILEn		-	-	±2.5	LSB
Differential linearity error ^a	DLEn		-	-	±1.5	LSB
Zero scale error ^a	ZSEn		-	-	±5.0	LSB
Full scale error ^a	FSEn		-	-	±5.0	LSB
Analog input voltage ^a	VAIN		AnVREFM		AnVREFP	V
Power on stabilization time ^b			-	-	1	μs
AnVDD current	AIDDn	ADAnBPC=0, with Diagnosis function	-	4.0	6.3	mA
		ADAnBPC=0, w/o Diagnosis function	-	5.2	8.1	mA
		ADAnBPC=1, with Diagnosis function	-	4.6	7.4	mA
		ADAnBPC=1, w/o Diagnosis function	-	6.2	9.2	mA
	AIDDnPD	Power down	-	1	-	μA
AnVREFP current	AIREFn		-	650	-	μA
Conversion result by Diagnosis function ^c	TESHn	AnVDD was converted	4015	-	4095	LSB
	TESHLn3	2/3 AnVDD was converted	2691	2731	2771	LSB
	TESHLn2	1/2 AnVDD was converted	2018	2048	2078	LSB
	TESHLn1	1/3 AnVDD was converted	1325	1365	1405	LSB
	TESLn	AGND was converted	0	-	80	LSB

a) The specification does not include the quantization error.

b) 'Power on' refers to
- setting ADCAnGPS = 1

c) The values given do not include influence of injected current

- Notes**
1. n: Number of macro instances. Refer to the User Manual for the detailed specification.
 2. m: Number of channels. Refer to the User Manual for the detailed specification.

7.16.2 12bit A/D (For channel ADCA0I0-5 when the S/H function is not used)

Table 7-12 12bit A/D (When channel Sample & Hold function is not used)

Parameter	Symbol	Condition	Ratings			Unit
			Min	Typ	Max	
Resolution	RES0SN		12	12	12	bit
Total conversion time	TCON0SN		1.5	-	10	μs
Overall error ^a	TOE0SN		-	-	±6.0	LSB
Non-linearity error ^a	ILE0SN		-	-	±2.5	LSB
Differential linearity error ^a	DLE0SN		-	-	±1.5	LSB
Zero scale error ^a	ZSE0SN		-	-	±5.0	LSB
Full scale error ^a	FSE0SN		-	-	±5.0	LSB
Analog input voltage ^a	VAIN0SN		A0VREFM	-	A0VREFP	V
Power on stabilization time ^b			-	-	1	μs
A0VDD current	AIDD0SN	ADA0BPC=0, with Diagnosis function	-	4.0	6.3	mA
		ADA0BPC=0, w/o Diagnosis function	-	5.2	8.1	mA
		ADA0BPC=1, with Diagnosis function	-	4.6	7.4	mA
		ADA0BPC=1, w/o Diagnosis function	-	6.2	9.2	mA
	AIDD0SNPD	Power down	-	1	-	μA
A0VREFP current	AIREF0SN		-	650	-	μA
Conversion result by Diagnosis function ^c	TESH0SN	A0VDD was converted	4015	-	4095	LSB
	TESHL0SN3	2/3 A0VDD was converted	2691	2731	2771	LSB
	TESHL0SN2	1/2 A0VDD was converted	2018	2048	2078	LSB
	TESHL0SN1	1/3 A0VDD was converted	1325	1365	1405	LSB
	TESL0SN	AGND was converted	0	-	80	LSB

a) The specification does not include the quantization error.

b) 'Power on' refers to
- setting ADCAnGPS = 1

c) The values given do not include influence of injected current

- Notes**
1. n: Number of macro instances. Refer to the User Manual for the detailed specification.
 2. m: Number of channels. Refer to the User Manual for the detailed specification.

7.16.3 12bit A/D (When channel S/H function is used)

Table 7-13 12bit A/D (When channel Sample & Hold function is used [ADCA010 to ADCA015])

Parameter	Symbol	Condition	Ratings			Unit
			Min	Typ	Max	
Resolution	RES0S		12	12	12	bit
Total conversion time	TCON0SN		1.8	-	12	μs
Sample & Hold time			50	-	-	μs
Overall error ^a	TOE0S		-	-	±8.0	LSB
Non-linearity error ^a	ILE0S		-	-	±4.0	LSB
Differential linearity error ^a	DLE0S		-	-	±2.5	LSB
Zero scale error ^a	ZSE0S		-	-	±6.0	LSB
Full scale error ^a	FSE0S		-	-	±6.0	LSB
Analog input voltage	VAIN0S		0.2	-	A0VREFP-0.2	V
Power on stabilization time ^b			-	-	1	μs
A0VDD current	AIDD0S	withDiagnosis function	-	Note3	22.1	mA
		w/o Diagnosis function	-	Note3	24.0	mA
	AIDD0SPD	Power down	-	1	-	μA
A0VREFP current	AIREF0S		-	650	-	μA
Conversion result by Diagnosis function ^c	TESHLS3	2/3 A0VDD was converted	2689	2731	2773	LSB
	TESHLS2	1/2 A0VDD was converted	2016	2048	2080	LSB
	TESHLS1	1/3 A0VDD was converted	1323	1365	1407	LSB

- a) The specification does not include the quantization error.
b) 'Power on' refers to
- setting ADCAnGPS = 1
c) The values given do not include influence of injected current

- Notes**
1. n: Number of macro instances. Refer to the User Manual for the detailed specification.
 2. m: Number of channels. Refer to the User Manual for the detailed specification.
 3. $AIDD_n + 1.72\text{mA} \times (\text{number of channels used with S/H})$

7.16.4 10bit A/D (for ADC channels without S/H functionality)

Table 7-14 10 bit A/D

Parameter	Symbol	Condition	Ratings			Unit
			Min	Typ	Max	
Resolution	RESn		10	10	10	bit
Total conversion time	TCONn		1.5		10	μs
Overall error ^a	TOEn	Excluding quantization error	-	-	±2.0	LSB
Non-linearity error ^a	ILEn		-	-	±1.5	LSB
Differential linearity error ^a	DLEn		-	-	±1.0	LSB
Zero scale error ^a	ZSEn		-	-	±1.5	LSB
Full scale error ^a	FSEn		-	-	±1.5	LSB
Analog input voltage ^a	VAIN		AnVREFM		AnVREFP	V
Power on stabilization time ^b			-		1	μs
AnVDD current	AIDDn	ADAnBPC=0, with Diagnosis function	-	4.0	6.3	mA
		ADAnBPC=0, w/o Diagnosis function	-	5.2	8.1	mA
		ADAnBPC=1, with Diagnosis function	-	4.6	7.4	mA
		ADAnBPC=1, w/o Diagnosis function	-	6.2	9.2	mA
	AIDDnPD	Power down	-	1	-	μA
AnVREFP current	AIREFn		-	500	-	μA
Conversion result by Diagnosis function ^c	TESHn	AnVDD was converted	1003		1023	LSB
	TESHLn3	2/3 AnVDD was converted	673	683	693	LSB
	TESHLn2	1/2 AnVDD was converted	504	512	520	LSB
	TESHLn1	1/3 AnVDD was converted	331	341	351	LSB
	TESLn	AGND was converted	0		20	LSB

a) The specification does not include the quantization error.

b) 'Power on' refers to
- setting ADCAnGPS = 1

c) The values given do not include influence of injected current

- Notes**
1. n: Number of macro instances. Refer to the User Manual for the detailed specification.
 2. m: Number of channels. Refer to the User Manual for the detailed specification.

7.16.5 10bit A/D (For channel ADCA010-5 when the S/H function is not used)

Table 7-15 10 bit A/D

Parameter	Symbol	Condition	Ratings			Unit
			Min	Typ	Max	
Resolution	RES0SN		10	10	10	bit
Total conversion time	TCON0SN		1.5		10	μs
Overall error ^a	TOE0SN		-	-	±2.0	LSB
Non-linearity error ^a	ILE0SN		-	-	±1.5	LSB
Differential linearity error ^a	DLE0SN		-	-	±1.0	LSB
Zero scale error ^a	ZSE0SN		-	-	±1.5	LSB
Full scale error ^a	FSE0SN		-	-	±1.5	LSB
Analog input voltage ^a	VAIN0SN		AnVREFM		AnVREFP	V
Power on stabilization time ^b			-	-	1	μs
AnVDD current	AIDD0SN	ADAnBPC=0, with Diagnosis function	-	4.0	6.3	mA
		ADAnBPC=0, w/o Diagnosis function	-	5.2	8.1	mA
		ADAnBPC=1, with Diagnosis function	-	4.6	7.4	mA
		ADAnBPC=1, w/o Diagnosis function	-	6.2	9.2	mA
	AIDD0SNPD	Power down	-	1	-	μA
AnVREFP current	AIREF0SN		-	500	-	μA
Conversion result by Diagnosis function ^c	TESH0SN	AnVDD was converted	1003	-	1023	LSB
	TESHL0SN3	2/3 AnVDD was converted	673	683	693	LSB
	TESHL0SN2	1/2 AnVDD was converted	504	512	520	LSB
	TESHL0SN1	1/3 AnVDD was converted	331	341	351	LSB
	TESL0SN	AGND was converted	0	-	20	LSB

a) The specification does not include the quantization error.

b) 'Power on' refers to
- setting ADCAnGPS = 1

c) The values given do not include influence of injected current

- Notes**
1. n: Number of macro instances. Refer to the User Manual for the detailed specification.
 2. m: Number of channels. Refer to the User Manual for the detailed specification.
 3. $AIDDn + 1.72mA \times (\text{number of channels used with S/H})$

7.16.6 10bit A/D (When channel S/H function is used)

Table 7-16 10 bit A/D

Parameter	Symbol	Condition	Ratings			Unit
			Min	Typ	Max	
Resolution	RES0S		10	10	10	bit
Total conversion time	TCON0S		1.84	-	12.2	μs
Sample & Hold time			50	-	-	μs
Overall error ^a	TOE0S		-	-	±2.5	LSB
Non-linearity error ^a	ILE0S		-	-	±2.0	LSB
Differential linearity error ^a	DLE0S		-	-	±1.5	LSB
Zero scale error ^a	ZSE0S		-	-	±2.0	LSB
Full scale error ^a	FSE0S		-	-	±2.0	LSB
Analog input voltage ^a	VAIN0S		0.2	-	A0VREFP-0.2	V
Power on stabilization time ^b			-	-	1	μs
AnVDD current	AIDD0S	ADAnBPC=1, with Diagnosis function	-	^c	22.1	mA
		ADAnBPC=1, w/o Diagnosis function	-	^c	24.0	mA
	AIDD0SPD	Power down	-	1	-	μA
AnVREFP current	AIREF0S		-	500	-	μA
Conversion result by Diagnosis function ^d	TESHL0S3	2/3 AnVDD was converted	672	683	694	LSB
	TESHL0S2	1/2 AnVDD was converted	503	512	521	LSB
	TESHL0S1	1/3 AnVDD was converted	330	341	352	LSB

- a) The specification does not include the quantization error.
b) 'Power on' refers to
- setting ADCAnGPS = 1
c) AIDDn x 1.72 x the number of used channels with Sample & Hold
d) The values given do not include influence of injected current

- Notes**
1. n: Number of macro instances. Refer to the User Manual for the detailed specification.
 2. m: Number of channels. Refer to the User Manual for the detailed specification.

7.16.7 Equivalent circuit

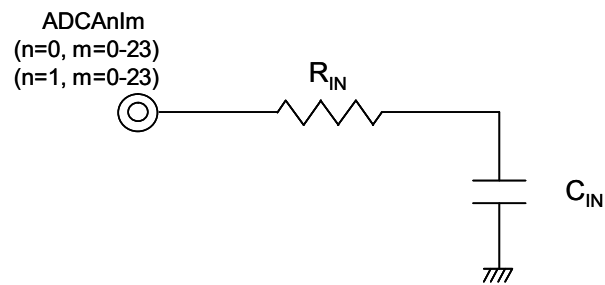

Terminals	Condition	R_{IN} [k Ω]	C_{IN} [pF]	
ADCA010-ADCA015	When S&H is used	0.7	3.6	
	When S&H is not used	ADA0BPC=0	1.6	12.6
		ADA0BPC=1	1.5	7.1
ADCA016-ADCA0123	ADA0BPC=0	1.2	11.9	
	ADA0BPC=1	1.1	7.1	
ADCA110-ADCA1123	ADA0BPC=0	1.2	11.9	
	ADA0BPC=1	1.1	7.1	

Caution These specifications are not tested in outgoing inspection. Therefore R_{IN} and C_{IN} values are not guaranteed and are reference values only. Additionally these values are specified as maximum values.

7.16.8 ADTRG timing

Parameter	Symbol	Condition	Ratings			Unit
			Min	Typ	Max	
ADCAnTRGm input High level width	tWADH	with digital noise filter	a	-	-	ns
		without digital noise filter	b	-	-	ns
ADCAnTRGm input Low level width	tWADL	with digital noise filter	a	-	-	ns
		without digital noise filter	b	-	-	ns

- a) 2, 3, 4 or 5 x T_{samp} + 20 (T_{samp} shows sampling period specified in noise filter).
More than 1 PCLK width of ADC macro must be kept regarding DNF pass through pulse width.
- b) $1 \times t_{SYNC} + 20$ (t_{SYNC} : 1 PCLK of ADC macro)

- Notes**
1. n: Number of macro instances. Refer to the User Manual for the detailed specification.
 2. m: Number of channels. Refer to the User Manual for the detailed specification.

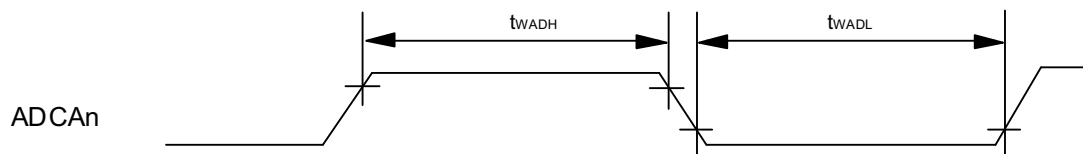

7.17 Key Return

Table 7-17

Parameter	Symbol	Condition	Ratings			Unit
			Min	Typ	Max	
KRn input High level width	t_{WKRH}		300	-	-	ns
KRn input Low level width	t_{WKRL}		300	-	-	ns

Note n: Number of instances. Refer to the User Manual for the detailed specification.

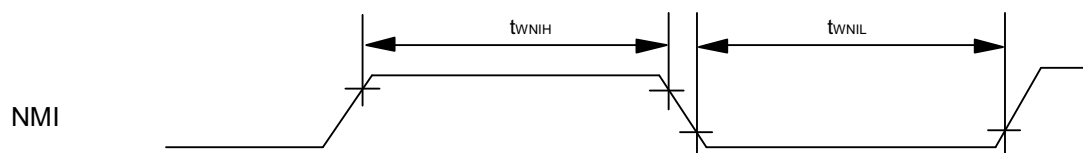

Chapter 8 Memory specification

8.1 Code flash specification

Table 8-1 Code flash

Parameter	Symbol	Condition	Ratings			Unit
			Min	Typ	Max	
Number of Re-Writes ^a	CWRT	Data retention 20 years	-	-	100	times
Programming Temperature	tPRG	(A) grade products	-40	-	85	°C
		(A1) grade products	-40	-	110	°C
		(A2) grade products	-40	-	125	°C

^{a)} Please contact RENESAS sales office regarding specification other than the above.

8.2 Data flash specification

Table 8-2 Data flash

Parameter	Symbol	Condition	Ratings			Unit
			Min	Typ	Max	
Number of Re-Writes ^a	DWRT1	Data retention 20 years	-	-	1000	times
	DWRT2	Data retention 15 years	-	-	5000	times
	DWRT3	Data retention 5 years	-	-	15000	times
Programming Temperature	tPRG	(A) grade products	-40	-	85	°C
		(A1) grade products	-40	-	110	°C
		(A2) grade products	-40	-	125	°C

^{a)} Please contact RENESAS sales office regarding specification other than the above.

8.3 Serial write operation specification

Serial write operation

Parameter	Symbol	Condition	Ratings			Unit
			Min	Typ	Max	
FLMD0 setup time	tDR		1	-	-	ms
RESET release	tPR		2	-	-	ms
FLMD0 pulse input start	tRP		-	100	-	ms
FLMD0 low/high level width	tPW		10	-	100	µs
FLMD0 raise time	tR		-	-	20	ns
FLMD0 fall time	tF		-	-	20	ns
Programming time		per 128 bit	-	-	50	µs
Erase time		per 4KB	-	-	54	ms

Chapter 9 Pinning and package specification

9.1 Pinning specification

(1) M1 Product

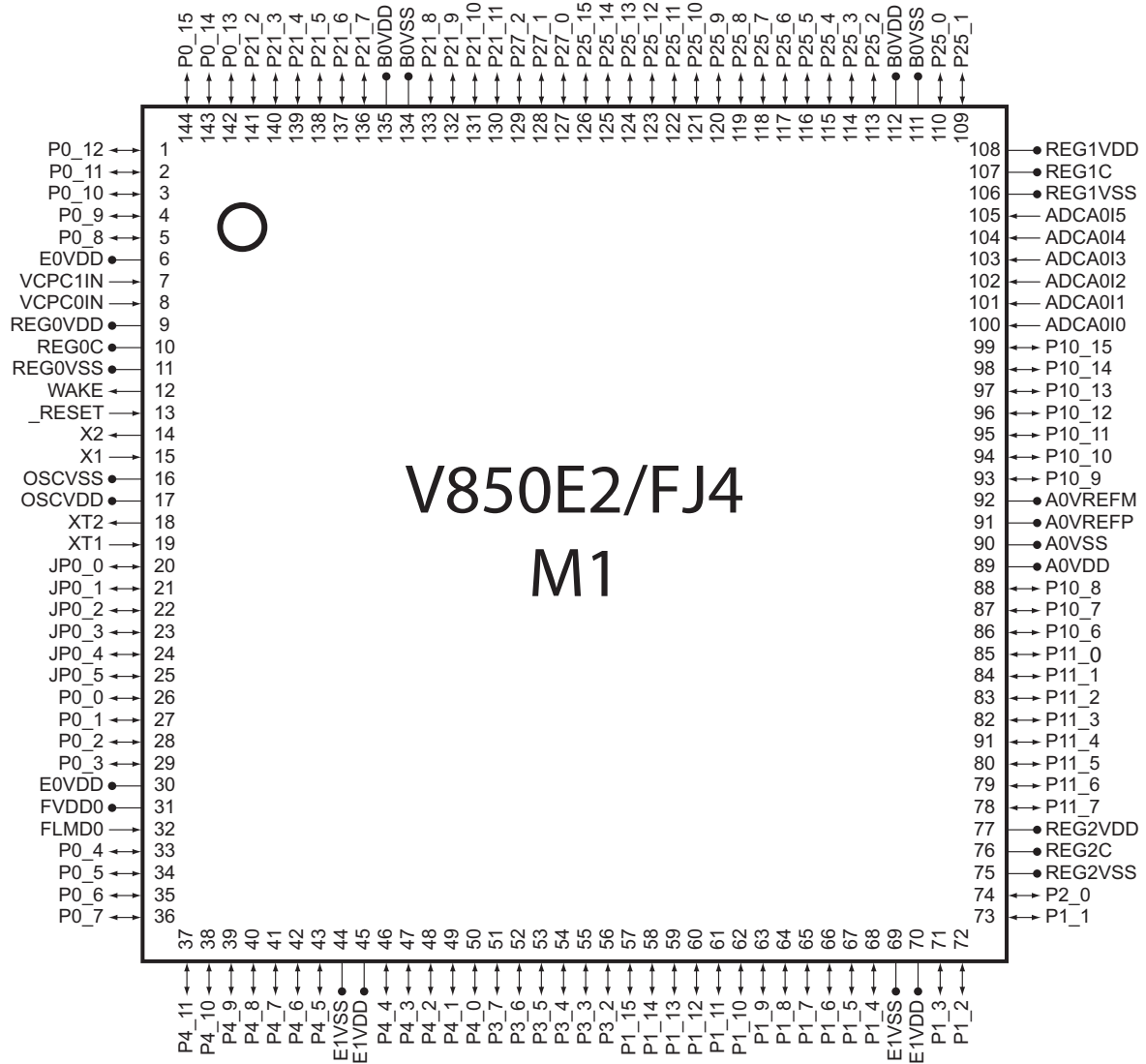

(2) M2 Product

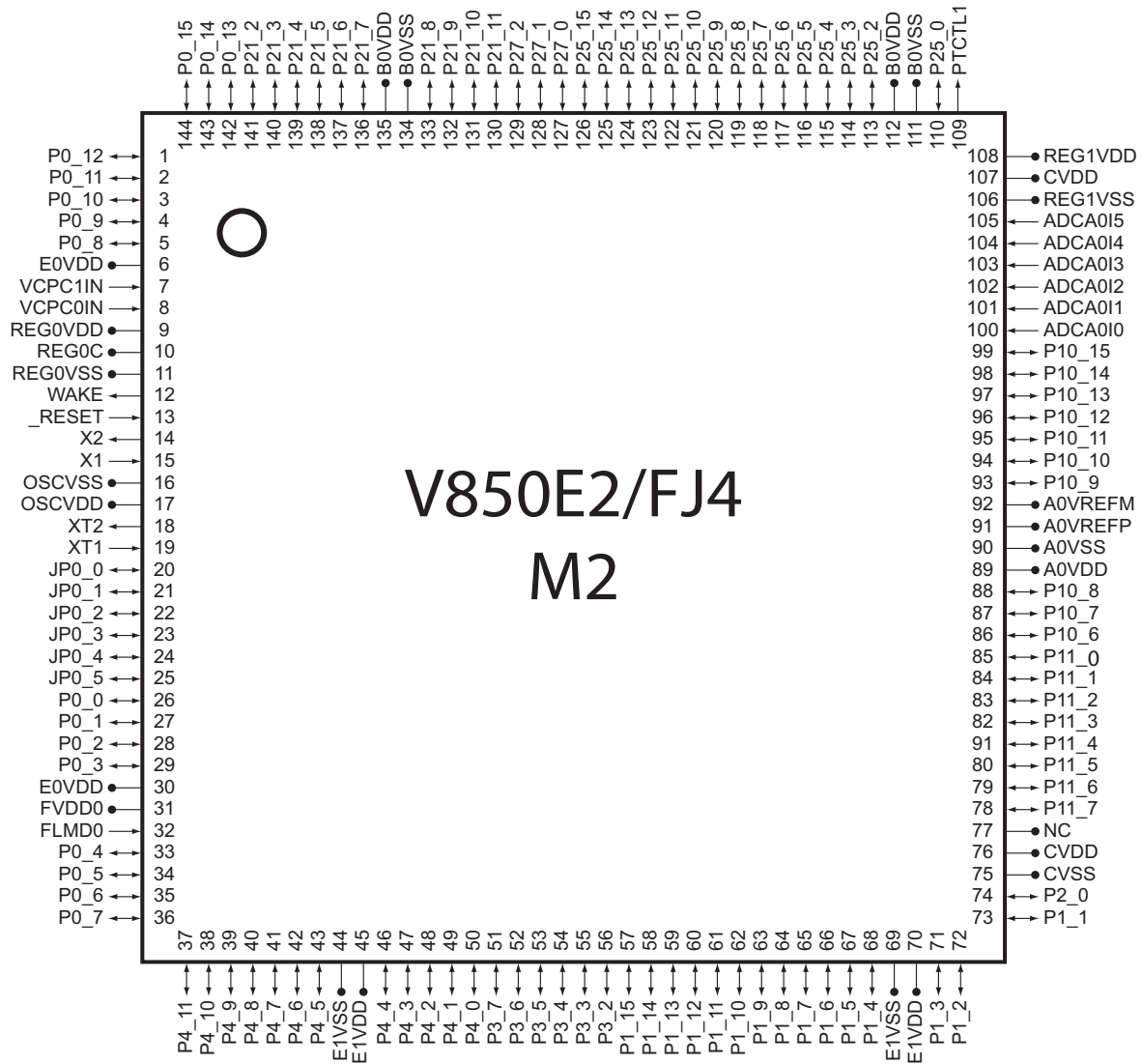

9.2 Package specification

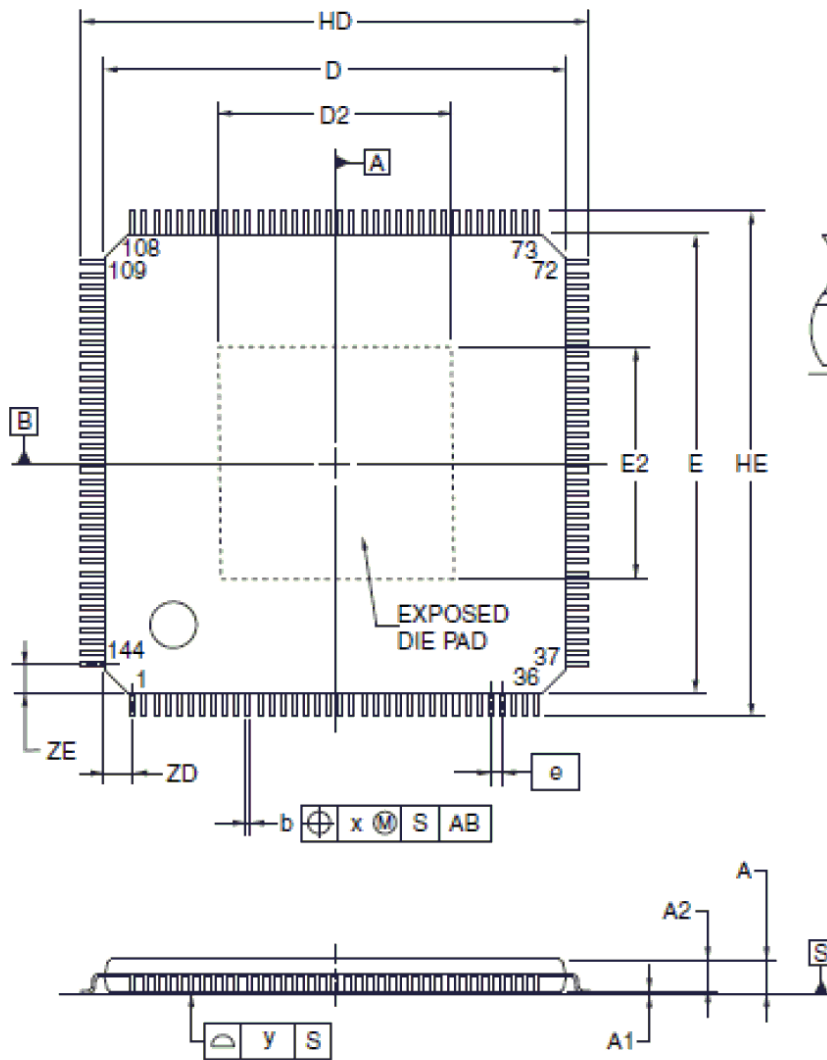

detail of lead end

(UNIT:mm)

ITEM	DIMENSIONS
D	20.00±0.20
E	20.00±0.20
HD	22.00±0.20
HE	22.00±0.20
D2	10.00
E2	10.00
A	1.60 MAX.
A1	0.10±0.05
A2	1.40±0.05
A3	0.25
b	0.20 ^{+0.07} _{-0.03}
c	0.125 ^{+0.075} _{-0.025}
L	0.50
Lp	0.60±0.15
L1	1.00±0.20
θ	3° ⁺ _{-3°}
B	0.50
x	0.08
y	0.08
ZD	1.25
ZE	1.25

T144GJ-50A-GBG

Chapter 10 Definition of terms

The following sections describe the meaning of several terms used in this document.

10.1 How to Read A/D Converter Characteristics Table

This section describes the meanings of the terms peculiar to the A/D converter.

(1) Resolution

The minimum analog input voltage that can be identified, i.e. the ratio of the analog input voltage to 1 digital output is called 1 LSB (Least Significant Bit). The ratio of 1 LSB to the full scale is expressed as %FSR (Full Scale Range). %FSR is the ratio, in percentage, of the range in which an analog input voltage can be converted, and is expressed as follows regardless of the resolution.

$$\begin{aligned} 1\%FSR &= (\text{Maximum value of analog input voltage that can be converted} - \\ &\quad \text{Minimum value of analog input voltage that can be converted})/100 \\ &= (AV_{REFP} - AV_{REFM})/100 \end{aligned}$$

1 LSB is as follows at a resolution of 10 bits:

$$\begin{aligned} 1 \text{ LSB} &= 1/2^{10} \\ &= 1/1,024 \\ &= 0.098\%FSR \end{aligned}$$

1 LSB is as follows at a resolution of 12 bits:

$$\begin{aligned} 1 \text{ LSB} &= 1/2^{12} \\ &= 1/4,096 \\ &= 0.024\%FSR \end{aligned}$$

The accuracy is determined by the total error, regardless of the resolution.

(2) Total error

This is the maximum value of the difference between the actually measured value and the theoretical value.

It is the total of the zero-scale error, full-scale error, linearity error, and a combination of these errors.

The total error shown in the characteristics table does not include the quantization error.

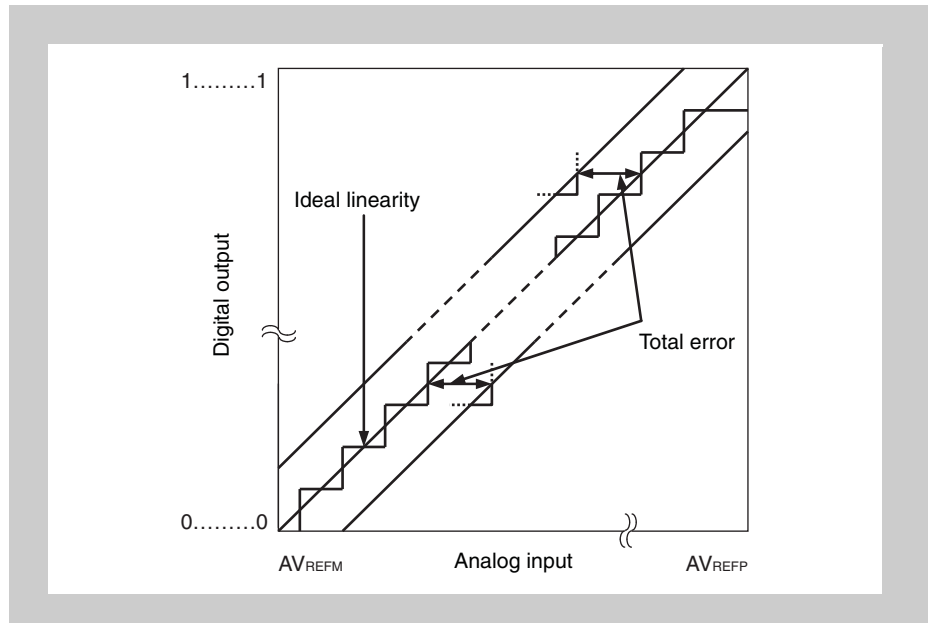

Figure 10-1 Total error

(3) Quantization error

This is the error of $\pm 1/2$ LSB that always occurs when an analog value is converted into a digital value. Because the A/D converter converts an analog input voltage in a range of $\pm 1/2$ LSB into the same digital code, the quantization error is unavoidable.

Note that this error is not included in the total error, zero-scale error, full-scale error, integral linearity error, and differential linearity error in the characteristics table.

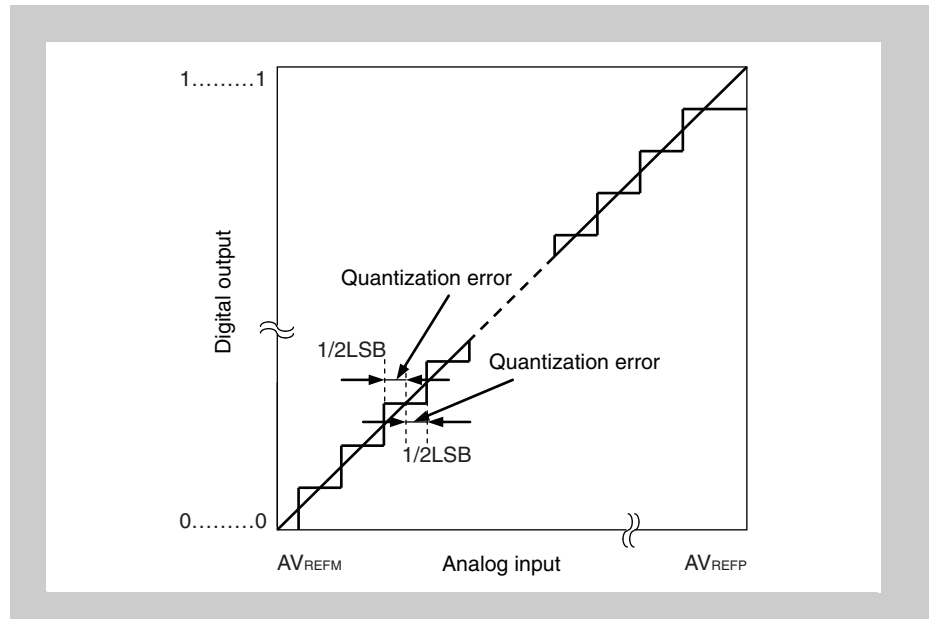

Figure 10-2 Quantization error

(4) Zero-scale error

This is the difference between the actually measured value of the analog input voltage and the theoretical value (1/2 LSB) when the digital output changes from 0...000 to 0...001.

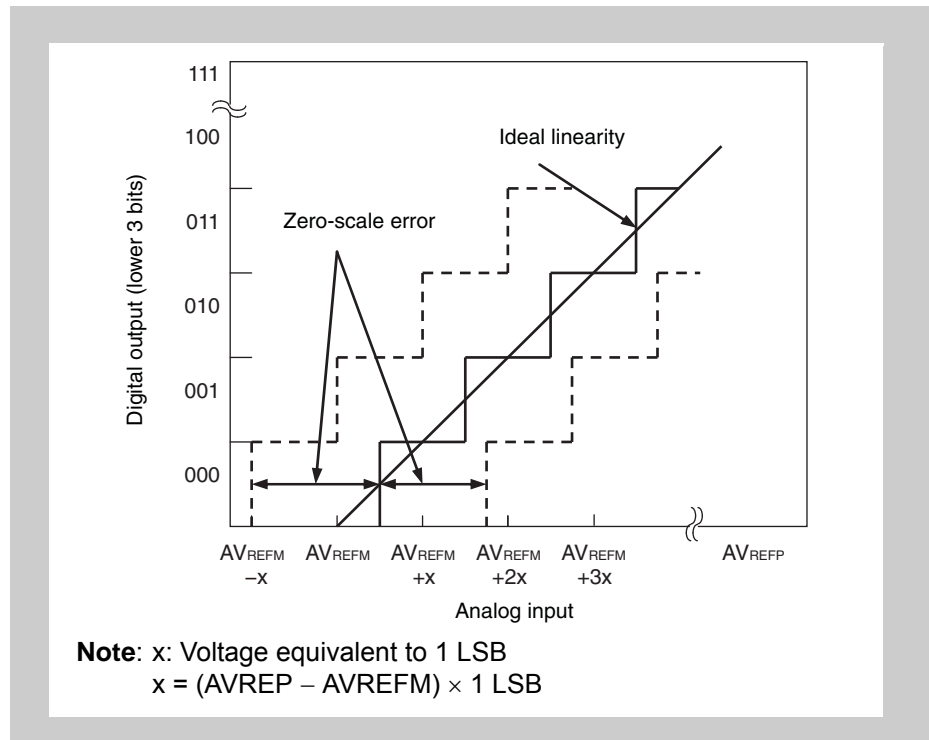

Figure 10-3 Zero-scale error

(5) Full-scale error

This is the difference between the actually measured value of the analog input voltage and the theoretical value (full scale - 3/2 LSB) when the digital output changes from 1...110 to 1...111.

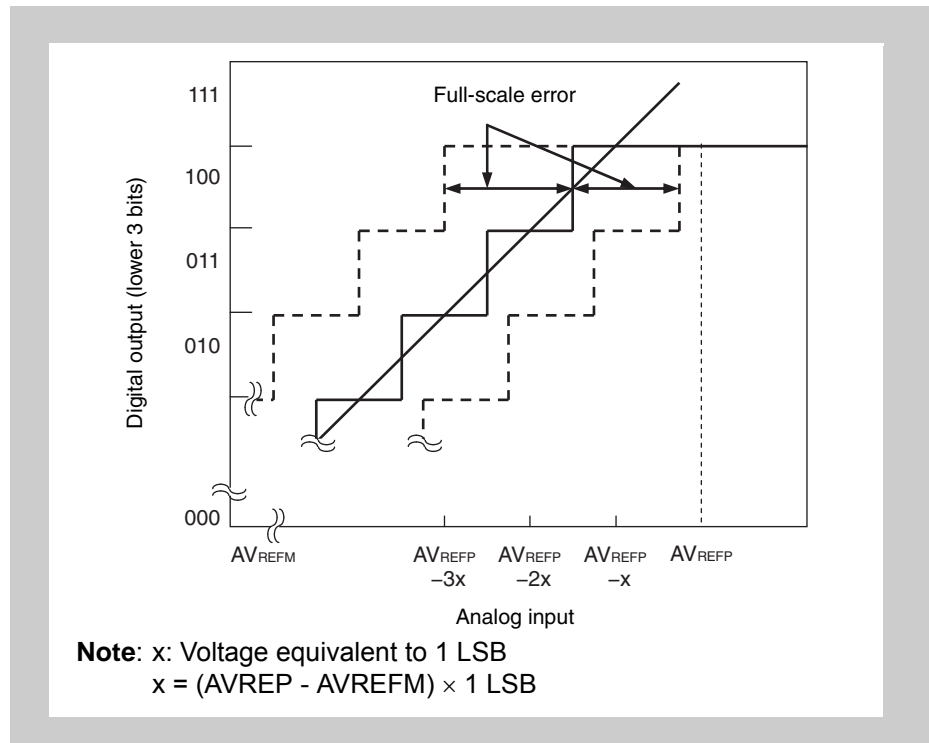

Figure 10-4 Full-scale error

(6) Differential linearity error

Ideally, the width at which a specific code is output is 1 LSB. The differential linearity error is the difference between the actually measured value of the width at which a specific code is output and the ideal value.

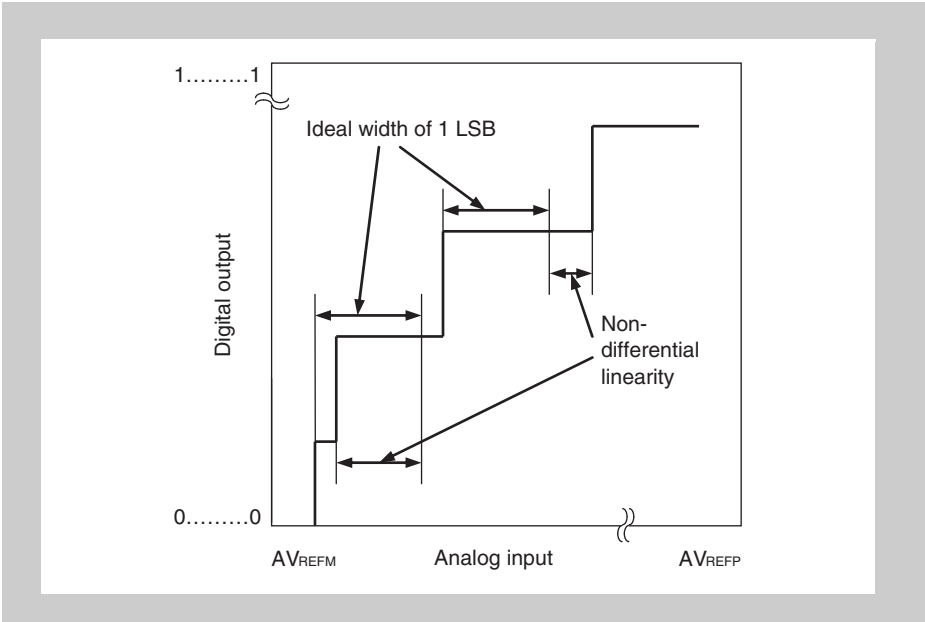

Figure 10-5 Differential linearity error

(7) Integral linearity error

This indicates the degree to which the conversion characteristic shifts from the ideal linearity, and indicates the maximum value of the difference between the actually measured value and the ideal linearity where the zero-scale error and full-scale error are 0.

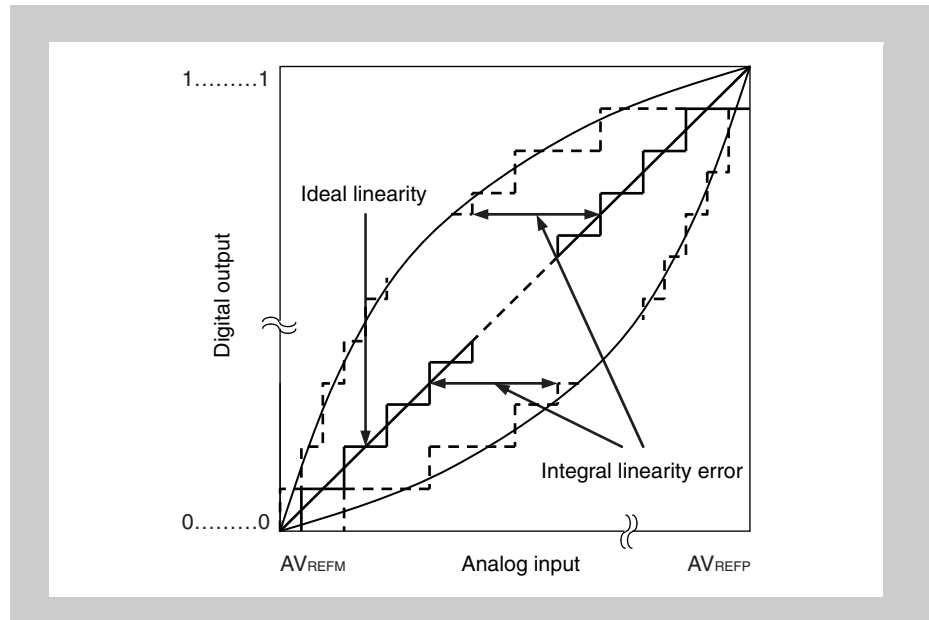

Figure 10-6 Integral linearity error

(8) Conversion time

This is the time from when an analog voltage is input until digital output is produced.

The conversion time in the characteristics table includes sampling time.

(9) Sampling time

This is the time during which the analog switch is on to input the analog voltage to the sample & hold circuit.

(10) A/D start time

This is the time from the A/D conversion trigger to the start of A/D conversion.

Revision History

Version	Date	Document number	Description
1.0	2013-05-24	R01DS0140ED0100	Initial version Document was EASE-DS-0031-1.3 Changes: - RIVS ISO0/ISO1 regulator value was 1.8V/ μ s is 5600V/s - Added FLMD0 / FLMD1 resistor values - Package drawing updated