

ISL70100SEH, ISL73100SEH

Radiation Hardened 40V Current-Sense Amplifiers

Description

The [ISL70100SEH](#) and [ISL73100SEH](#) are radiation hardened 40V current sense amplifiers built on the Renesas proprietary PR40 SOI process. These devices have a wide power supply range of 2.7V to 40V. The input common-mode voltage is independent of the supply voltage and extends from -0.3V to 40.0V, making them ideal to use in both high-side and low-side applications.

The ISL70100SEH and ISL73100SEH are trans-conductance amplifiers that monitor current using an external sense resistor and output a current proportional to the sensed voltage. The overall voltage gain is adjustable with a single resistor from the output to ground.

These amplifiers have an extremely low offset voltage and input bias currents, making them ideal for precision sensing applications. They have a minimum bandwidth of 500kHz with a slew rate of 500μA/μs that make them useful for current feedback in telemetry applications. When the parts are powered down (V+ = V- = 0V), the sense pins (RS+, RS-) are high impedance to avoid loading the monitored circuit.

The parts are available in a hermetically sealed 10 Ld ceramic flat-pack package or die form and operate across the full-range military temperature of -55°C to +125°C.

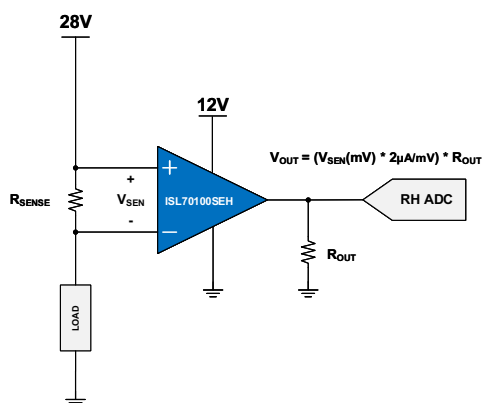

Figure 1. Typical Application: High-Side Current Sense for 28V Supply Rail

Features

- Electrically Screened to SMD [5962-20212](#)
- Power supply range: 2.7V to 40V
- Input common-mode range: -0.3V to 40V
- Transconductance: 2μA/mV (typical)
 - ±1% accuracy (T_A = 25°C)
 - ±1.5% accuracy (T_A = -55°C, 125°C)
- Voltage offset: 10μV (typical), V+ = 12V
- Adjustable gain with a single resistor
- Radiation acceptance testing - ISL70100SEH
 - HDR (50-300rad(Si)/s): 100krad(Si)
 - LDR (<10mrads(Si)/s): 75krad(Si)
- Radiation acceptance testing - ISL73100SEH
 - LDR (<10mrads(Si)/s): 75krad(Si)
- SEE hardness (see SEE report for details)
 - No SEB (V+ = 35V): 86.4MeV•cm²/mg
 - No SEB (V+ = 42V): 43.0MeV•cm²/mg

Applications

- High-side or low-side current sensing
- Battery monitoring
- Power management
- Motor control
- Command, telemetry, and control systems

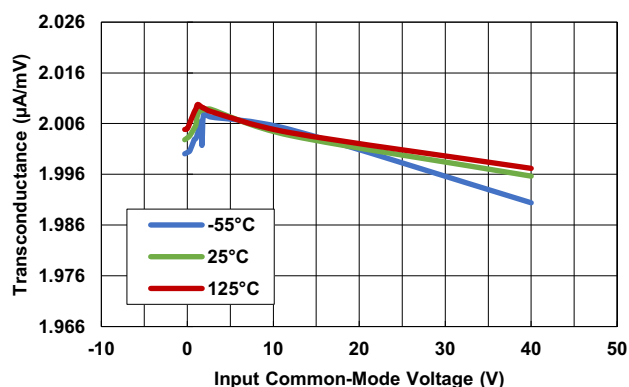

Figure 2. Transconductance, V+ = 12V

Contents

1. Overview	3
1.1 Block Diagram	3
2. Pin Information	4
2.1 Pin Assignments	4
2.2 Pin Descriptions	4
3. Specifications	5
3.1 Absolute Maximum Ratings	5
3.2 Thermal Information	5
3.3 Recommended Operating Conditions	5
3.4 Electrical Specifications	6
3.4.1 $V_+ = 12V$	6
3.4.2 $V_+ = 2.7V$	7
3.4.3 $V_+ = 40V$	9
4. Typical Performance Curves	11
5. Functional Description	18
5.1 Output Signal Range	18
5.2 Input Common-Mode Range	18
5.3 Crossover Region	18
5.4 Sources of Error	19
5.4.1 Input Impedance of Downstream Devices	19
5.4.2 Input Offset Voltage	19
5.4.3 Input Bias and Offset Current	19
5.4.4 Sensed Current Error	19
6. Applications Information	20
6.1 Selection of the External Current-Sense Resistor	20
6.2 Gain Setting	20
6.3 Selection of Output Resistor	20
6.4 Output Filtering	20
6.5 Response Time	21
7. Die Characteristics	21
7.1 Metallization Mask Layout	22
8. Package Outline Drawing	23
9. Ordering Information	23
10. Revision History	24
A. ECAD Design Information	25

1. Overview

1.1 Block Diagram

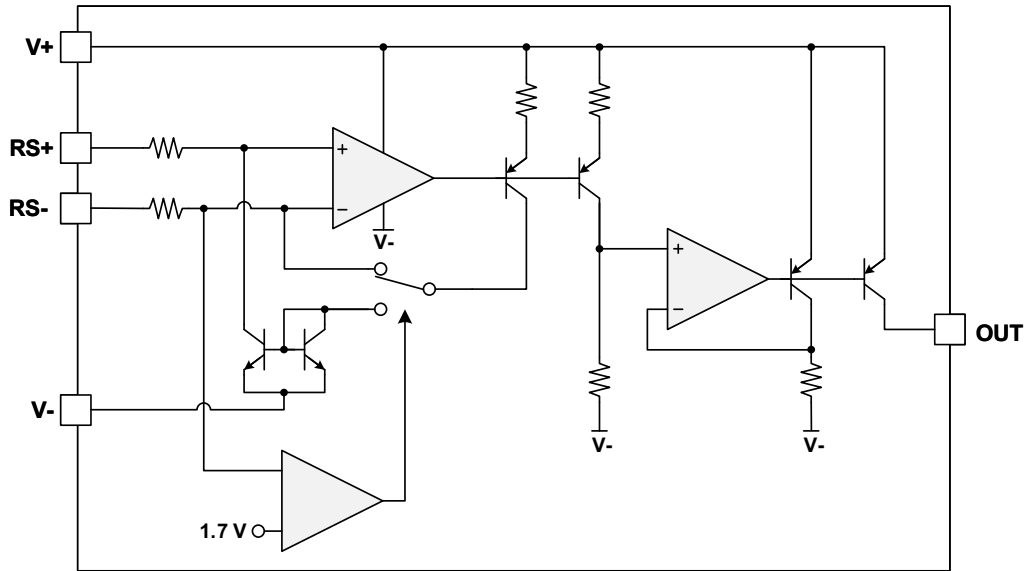

Figure 3. ISL70100SEH Block Diagram

2. Pin Information

2.1 Pin Assignments

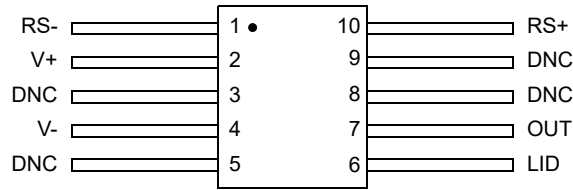
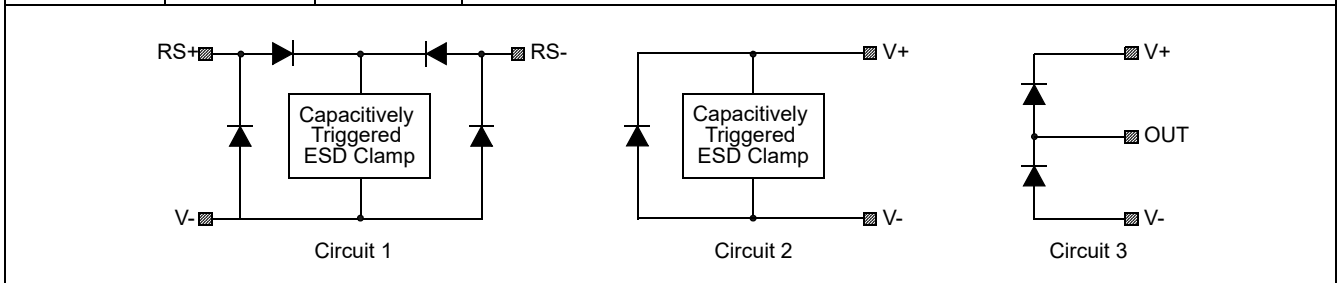

Figure 4. Pin Assignments - Top View

2.2 Pin Descriptions

Pin Number	Pin Name	ESD Circuit	Description
1	RS-	1	Negative sense input of current sense amplifier
2	V+	2	Positive power supply
3	DNC	-	Do not connect, leave floating. This pin leaks to V-.
4	V-	-	Negative power supply
5	DNC	-	Do not connect, leave floating. This pin leaks to V-.
6	LID	-	This pin is electrically connected to the lid, connect this pin to V- to avoid floating metal. This pin does not connect to the die.
7	OUT	3	Output of the transconductance amplifier
8	DNC	-	Do not connect, leave floating. This pin leaks to V-.
9	DNC	-	Do not connect, leave floating. This pin leaks to V-.
10	RS+	1	Positive sense input of current sense amplifier



3. Specifications

3.1 Absolute Maximum Ratings

Caution: Do not operate at or near the maximum ratings listed for extended periods of time. Exposure to such conditions can adversely impact product reliability and result in failures not covered by warranty.

Parameter	Minimum	Maximum	Unit
V+ to V-	-	42	V
Input Common Mode Voltage Range (VRS+, VRS-)	-0.3	42	V
Maximum Input Voltage Differential (RS+ to RS-)	-42	42	V
V+ to V- ^[1]	-	35	V
Input Voltage Range (VRS+, VRS-) ^[1]	-0.3	35	V
Maximum Input Voltage Differential (RS+ to RS-) ^[1]	-35	35	V
V+ to V- ^[2]	-	42	V
Input Voltage Range (VRS+, VRS-) ^[2]	-0.3	42	V
Maximum Input Voltage Differential (RS+ to RS-) ^[2]	-42	42	V
Maximum Differential Input Current	-	4	mA
Maximum Power Supply Ramp Rate	-	10	V/ μ s
Human Body Model (Tested per MIL-STD-883 TM3015)	-	4	kV
Charged Device Model (Tested per JS-002-2014)	-	2	kV

1. Tested in a heavy ion environment at LET = 86.4MeV \cdot cm²/mg at +125°C (T_C).
2. Tested in a heavy ion environment at LET = 43MeV \cdot cm²/mg at +125°C (T_C).

3.2 Thermal Information

Parameter	Package	Symbol	Conditions	Typical Value	Unit
Thermal Resistance	10 Ld CDFP Package	θ_{JA} ^[1]	Junction to ambient	39	°C/W
		θ_{JC} ^[2]	Junction to case	7	°C/W

1. θ_{JA} is measured in free air with the component mounted to a high-effective thermal conductivity test board with direct attach features. See [IB379](#).
2. For θ_{JC} , the case temperature location is taken at the center of the package underside.

Parameter	Minimum	Maximum	Unit
Maximum Junction Temperature	-	+150	°C
Maximum Storage Temperature Range	-65	+150	°C

3.3 Recommended Operating Conditions

Parameter	Minimum	Maximum	Unit
V+ to V-	2.7	40	V
Input Common-Mode Voltage Range (from V-)	-0.3	40	V
Input Voltage Differential (RS+ to RS-)	0	150	mV
Temperature	-55	+125	°C

3.4 Electrical Specifications

3.4.1 V+ = 12V

Recommended operating conditions, $V_+ = V_{RS+} = 12V$, $V_- = 0V$, $V_{SEN} = (V_{RS+} - V_{RS-})$, $R_{OUT} = 25k\Omega$ and $T_A = +25^\circ C$, unless otherwise specified. **Boldface limits apply across the operating temperature range from $-55^\circ C$ to $+125^\circ C$; over a Total Ionizing Dose (TID) of 100krad(Si) with an exposure rate of 50-300rad(Si)/s at $25^\circ C$ (ISL70100SEH only); or over a TID of 75krad(Si) with an exposure rate of $<10\text{mrad(Si)/s}$ at $25^\circ C$.**

Parameter	Symbol	Test Conditions	Min ^[1]	Typ ^[2]	Max ^[1]	Unit
Input Specifications						
Input Common-Mode Voltage Range	V_{CM}	Assured by CMRR Test	-0.3	-	40	V
Transconductance	g_m	$V_{SEN} = 25\text{mV}$ to 150mV , $V_{RS+} = V_+$, $T_A = +25^\circ C$	1.976	1.997	2.016	$\mu A/mV$
		$V_{SEN} = 25\text{mV}$ to 150mV , $V_{RS+} = V_+$, $T_A = -55^\circ C, +125^\circ C$	1.966	-	2.026	$\mu A/mV$
		$V_{SEN} = 25\text{mV}$ to 150mV , $V_{RS+} = V_+$, $T_A = +25^\circ C$, Post Radiation	1.976	1.997	2.016	$\mu A/mV$
		$V_{SEN} = 25\text{mV}$ to 150mV , $V_{RS+} = 0V$, $T_A = +25^\circ C$	1.940	2.009	2.060	$\mu A/mV$
		$V_{SEN} = 25\text{mV}$ to 150mV , $V_{RS+} = 0V$, $T_A = -55^\circ C, +125^\circ C$	1.930	-	2.070	$\mu A/mV$
		$V_{SEN} = 25\text{mV}$ to 150mV , $V_{RS+} = 0V$, $T_A = +25^\circ C$, Post Radiation	1.940	2.009	2.060	$\mu A/mV$
Input Offset Voltage	V_{OS}	$V_{SEN} = 5\text{mV}$, $T_A = +25^\circ C$	-400	10	400	μV
		$V_{SEN} = 5\text{mV}$, $T_A = -55^\circ C, +125^\circ C$	-700	-	700	μV
		$V_{SEN} = 5\text{mV}$, $T_A = +25^\circ C$, Post Radiation	-400	-20	400	μV
		$V_{SEN} = 5\text{mV}$, $V_{RS+} = 0V$, $T_A = +25^\circ C$	-400	10	400	μV
		$V_{SEN} = 5\text{mV}$, $V_{RS+} = 0V$, $T_A = -55^\circ C, +125^\circ C$	-800	-	700	μV
		$V_{SEN} = 5\text{mV}$, $V_{RS+} = 0V$, $T_A = +25^\circ C$, Post Radiation	-400	-50	400	μV
Input Bias Current	I_{BIAS}	$V_{SEN} = 0\text{mV}$	-	12	25	μA
		$V_{SEN} = 0\text{mV}$, $V_{RS+} = 0V$	-25	-8		μA
Input Offset Current	I_{OS}	$V_{SEN} = 0\text{mV}$	-1	-	1	μA
		$V_{SEN} = 0\text{mV}$, $V_{RS+} = 0V$	-1	-	1	μA
Input Bias Current (Powered Off)	I_{OFF}	$V_+ = V_{SEN} = 0\text{mV}$, $V_{RS+} = 12V$	-0.8	-	0.8	μA
Common-Mode Rejection Ratio	CMRR	$V_{SEN} = 5\text{mV}$, $V_{RS+} = 2.7V$, $40V$	90	103	-	dB
		$V_{SEN} = 5\text{mV}$, $V_{RS+} = 2.7V$, $40V$, $T_A = -55^\circ C, +125^\circ C$	85	-	-	dB
		$V_{SEN} = 5\text{mV}$, $V_{RS+} = 2.7V$, $40V$, Post Radiation	90	103	-	dB
		$V_{SEN} = 5\text{mV}$, $V_{RS+} = -0.3V$, $40V$	90	106	-	dB
		$V_{SEN} = 5\text{mV}$, $V_{RS+} = -0.3V$, $40V$, $T_A = -55^\circ C, +125^\circ C$	85	-	-	dB
		$V_{SEN} = 5\text{mV}$, $V_{RS+} = -0.3V$, $40V$, Post Radiation	90	106	-	dB
Output Specifications						
Minimum Output Voltage	V_{OL}	$V_{SEN} = 0\text{mV}$	-	-	20	mV

ISL70100SEH, ISL73100SEH Datasheet

Recommended operating conditions, $V_+ = V_{RS+} = 12V$, $V_- = 0V$, $V_{SEN} = (V_{RS+} - V_{RS-})$, $R_{OUT} = 25k\Omega$ and $T_A = +25^\circ C$, unless otherwise specified. **Boldface limits apply across the operating temperature range from $-55^\circ C$ to $+125^\circ C$; over a Total Ionizing Dose (TID) of $100krad(Si)$ with an exposure rate of $50-300rad(Si)/s$ at $25^\circ C$ (ISL70100SEH only); or over a TID of $75krad(Si)$ with an exposure rate of $<10mrad(Si)/s$ at $25^\circ C$. (Cont.)**

Parameter	Symbol	Test Conditions	Min ^[1]	Typ ^[2]	Max ^[1]	Unit
Maximum Output Voltage	V_{OH}	$A_V = 100$, $V_{SEN} = 120mV$	10.0	10.7	11.4	V
Minimum Guaranteed Linear Output Voltage	OVR	$V_{SEN} = 150mV$, $R_L = OPEN$	10	-	-	V
Maximum Linear Output Current Range	I_{OUT}	$R_{OUT} = 0\Omega$, $T_A = -55^\circ C, +25^\circ C, +125^\circ C$	1200	1550	1800	μA
		$R_{OUT} = 0\Omega$, Post Radiation	1000	1250	1800	μA
Short-Circuit Current	-	$V_{RS+} = 40V$, $V_{RS-} = 0V$, $R_{OUT} = 0\Omega$, $T_A = -55^\circ C, +25^\circ C, +125^\circ C$	1200	1550	1800	μA
		$V_{RS+} = 40V$, $V_{RS-} = 0V$, $R_{OUT} = 0\Omega$, Post Radiation	1000	1250	1800	μA
Power Supply Specifications						
Power Supply Range	V_+	Assured by PSRR Test	2.7	-	40	V
Supply Current	I_+	$V_{SEN} = 0mV$, $V_{RS+} = 0V$, V_+	-	250	400	μA
Power Supply Rejection Ratio	PSRR	$V_{SEN} = 5mV$, $V_{RS+} = 0V, 40V$, $V_+ = 2.7V, 40V$	90	96	-	dB
		$V_{SEN} = 5mV$, $V_{RS+} = 0V, 40V$, $V_+ = 2.7V, 40V$, $T_A = -55^\circ C, +125^\circ C$	85	-	-	dB
		$V_{SEN} = 5mV$, $V_{RS+} = 0V, 40V$, $V_+ = 2.7V, 40V$, Post Radiation	90	95	-	dB
AC Specifications						
500kHz Attenuation	Att_{500kHz}	$V_{SEN} = 50mV$, $C_L = 10pF$, $A_V = 10$, $f_{TEST} = 1kHz, 500kHz$	-3	-0.17	-	dB
Settling Time	t_S	$V_{SEN} = 5mV$ to $150mV$ (to 1% of final value)	-	0.8	-	μs
Input Step Response Time	t_{RES}	$V_{SEN} = 5mV$ to $150mV$ 50% of input to 50% of output	-	0.32	1	μs
Slew Rate	SR	$V_{SEN} = 5mV$ to $150mV$ ($T_A = +25^\circ C$)	0.50	1.25	2.50	$mA/\mu s$
		$V_{SEN} = 5mV$ to $150mV$ ($T_A = +125^\circ C$)	0.50	1.90	2.50	$mA/\mu s$
		$V_{SEN} = 5mV$ to $150mV$ ($T_A = -55^\circ C$)	0.45	0.80	2.50	$mA/\mu s$
		$V_{SEN} = 5mV$ to $150mV$ ($T_A = +25^\circ C$, Post Rad)	0.50	1.25	2.50	$mA/\mu s$

- Parameters with MIN and/or MAX limits are 100% tested at $-55^\circ C$, $+25^\circ C$ and $+125^\circ C$, unless otherwise specified.
- Typical values shown are not guaranteed.

3.4.2 $V_+ = 2.7V$

Recommended operating conditions, $V_+ = V_{RS+} = 2.7V$, $V_- = 0V$, $V_{SEN} = (V_{RS+} - V_{RS-})$, $R_{OUT} = 3.33k\Omega$ and $T_A = +25^\circ C$ unless otherwise specified. **Boldface limits apply across the operating temperature range from $-55^\circ C$ to $+125^\circ C$; over a Total Ionizing Dose (TID) of $100krad(Si)$ with an exposure rate of $50-300rad(Si)/s$ at $25^\circ C$ (ISL70100SEH only); or over a TID of $75krad(Si)$ with an exposure rate of $<10mrad(Si)/s$ at $25^\circ C$.**

Parameter	Symbol	Test Conditions	Min ^[1]	Typ ^[2]	Max ^[1]	Unit
Input Specifications						
Input Common-Mode Voltage Range	V_{CM}	Assured by CMRR Test	-0.3		40	V

ISL70100SEH, ISL73100SEH Datasheet

Recommended operating conditions, $V_+ = V_{RS+} = 2.7V$, $V_- = 0V$, $V_{SEN} = (V_{RS+} - V_{RS-})$, $R_{OUT} = 3.33k\Omega$ and $T_A = +25^\circ C$ unless otherwise specified. **Boldface limits apply across the operating temperature range from $-55^\circ C$ to $+125^\circ C$; over a Total Ionizing Dose (TID) of 100krad(Si) with an exposure rate of 50-300rad(Si)/s at $25^\circ C$ (ISL70100SEH only); or over a TID of 75krad(Si) with an exposure rate of $<10\text{mrad(Si)/s}$ at $25^\circ C$.** (Cont.)

Parameter	Symbol	Test Conditions	Min ^[1]	Typ ^[2]	Max ^[1]	Unit
Transconductance	g_m	$V_{SEN} = 25\text{mV to } 150\text{mV}$, $V_{RS+} = V_+$ $T_A = +25^\circ C$	1.986	2.007	2.026	$\mu A/mV$
		$V_{SEN} = 25\text{mV to } 150\text{mV}$, $V_{RS+} = V_+$, $T_A = -55^\circ C, +125^\circ C$	1.976	-	2.036	$\mu A/mV$
		$V_{SEN} = 25\text{mV to } 150\text{mV}$, $V_{RS+} = V_+$, $T_A = +25^\circ C$, Post Radiation	1.986	2.007	2.026	$\mu A/mV$
		$V_{SEN} = 25\text{mV to } 150\text{mV}$, $V_{RS+} = 0V$ $T_A = +25^\circ C$	1.940	2.013	2.060	$\mu A/mV$
		$V_{SEN} = 25\text{mV to } 150\text{mV}$, $V_{RS+} = 0V$, $T_A = -55^\circ C, +125^\circ C$	1.930	-	2.070	$\mu A/mV$
		$V_{SEN} = 25\text{mV to } 150\text{mV}$, $V_{RS+} = 0V$, $T_A = +25^\circ C$, Post Radiation	1.940	2.013	2.060	$\mu A/mV$
Input Offset Voltage	V_{OS}	$V_{SEN} = 5\text{mV}$ $T_A = +25^\circ C$	-300	400	1000	μV
		$V_{SEN} = 5\text{mV}$ $T_A = -55^\circ C, +125^\circ C$	-600	-	1300	μV
		$V_{SEN} = 5\text{mV}$ $T_A = +25^\circ C$, Post Radiation	-300	320	1000	μV
		$V_{SEN} = 5\text{mV}$, $V_{RS+} = 0V$ $T_A = +25^\circ C$	-300	250	900	μV
		$V_{SEN} = 5\text{mV}$, $V_{RS+} = 0V$ $T_A = -55^\circ C, +125^\circ C$	-700	-	1300	μV
		$V_{SEN} = 5\text{mV}$, $V_{RS+} = 0V$ $T_A = +25^\circ C$, Post Radiation	-300	100	900	μV
Input Bias Current	I_{BIAS}	$V_{SEN} = 0\text{mV}$	-	11	25	μA
		$V_{SEN} = 0\text{mV}$, $V_{RS+} = 0V$	-25	-8		μA
Input Offset Current	I_{OS}	$V_{SEN} = 0\text{mV}$, $V_{RS+} = 0V$, V_+	-1	-	1	μA
Input Bias Current (Powered Off)	I_{OFF}	$V_+ = V_{SEN} = 0\text{mV}$, $V_{RS+} = 2.7V$	-1	-	1	μA
Common-Mode Rejection Ratio	CMRR	$V_{SEN} = 5\text{mV}$, $V_{RS+} = 2.7V$, 40V	90	103	-	dB
		$V_{SEN} = 5\text{mV}$, $V_{RS+} = 2.7V$, 40V, $T_A = -55^\circ C, +125^\circ C$	85	-	-	dB
		$V_{SEN} = 5\text{mV}$, $V_{RS+} = 2.7V$, 40V, Post Radiation	90	103	-	dB
		$V_{SEN} = 5\text{mV}$, $V_{RS+} = -0.3V$, 40V	90	106	-	dB
		$V_{SEN} = 5\text{mV}$, $V_{RS+} = -0.3V$, 40V, $T_A = -55^\circ C, +125^\circ C$	85	-	-	dB
		$V_{SEN} = 5\text{mV}$, $V_{RS+} = -0.3V$, 40V, Post Radiation	90	106	-	dB
Output Specifications						
Minimum Output Voltage	V_{OL}	$V_{SEN} = 0\text{mV}$	-	-	14	mV
Maximum Output Voltage	V_{OH}	Referred to V_+ , $A_V = 100$, $V_{SEN} = 27\text{mV}$	0.7	1.4	2.1	V
Minimum Guaranteed Linear Output Voltage	OVR	$V_{SEN} = 150\text{mV}$, $R_L = \text{Open}$	0.7	-	-	V
Maximum Linear Output Current Range	I_{OUT}	$R_{OUT} = 0\Omega$	300	600	1100	μA
Short-Circuit Current	-	$V_{RS+} = 40V$, $V_{RS-} = 0V$, $R_{OUT} = 0\Omega$	300	600	1100	μA

ISL70100SEH, ISL73100SEH Datasheet

Recommended operating conditions, $V_+ = V_{RS+} = 2.7V$, $V_- = 0V$, $V_{SEN} = (V_{RS+} - V_{RS-})$, $R_{OUT} = 3.33k\Omega$ and $T_A = +25^\circ C$ unless otherwise specified. **Boldface limits apply across the operating temperature range from $-55^\circ C$ to $+125^\circ C$; over a Total Ionizing Dose (TID) of 100krad(Si) with an exposure rate of 50-300rad(Si)/s at $25^\circ C$ (ISL70100SEH only); or over a TID of 75krad(Si) with an exposure rate of $<10\text{mrad(Si)/s}$ at $25^\circ C$.** (Cont.)

Parameter	Symbol	Test Conditions	Min ^[1]	Typ ^[2]	Max ^[1]	Unit
Power Supply Specifications						
Supply Current	I+	$V_{SEN} = 0mV$, $V_{RS+} = 0V$, V_+	-	240	400	μA
AC Specifications						
500kHz Attenuation	Att _{500kHz}	$V_{SEN} = 50mV$, $C_L = 10pF$, $A_V = 10$, $f_{TEST} = 1kHz$, 500kHz	-3	-0.20	-	dB
Settling Time	t _S	$V_{SEN} = 5mV$ to 150mV (to 1% of final value)	-	0.8	-	μs
Input Step Response Time	t _{RES}	$V_{SEN} = 5mV$ to 150mV 50% of input to 50% of output	-	0.4	1	μs
Slew Rate	SR	$V_{SEN} = 5mV$ to 150mV ($T_A = +25^\circ C$)	0.50	1.2	2.50	$\text{mA}/\mu s$
		$V_{SEN} = 5mV$ to 150mV ($T_A = +125^\circ C$)	0.50	1.8	2.50	$\text{mA}/\mu s$
		$V_{SEN} = 5mV$ to 150mV ($T_A = -55^\circ C$)	0.45	0.75	2.50	$\text{mA}/\mu s$
		$V_{SEN} = 5mV$ to 150mV ($T_A = +25^\circ C$, Post Rad)	0.50	1.1	2.50	$\text{mA}/\mu s$

- Parameters with MIN and/or MAX limits are 100% tested at $-55^\circ C$, $+25^\circ C$ and $+125^\circ C$, unless otherwise specified.
- Typical values shown are not guaranteed.

3.4.3 $V_+ = 40V$

Recommended operating conditions, $V_+ = V_{RS+} = 40V$, $V_- = 0V$, $V_{SEN} = (V_{RS+} - V_{RS-})$, $R_{OUT} = 25k\Omega$ and $T_A = +25^\circ C$ unless otherwise specified. **Boldface limits apply across the operating temperature range from $-55^\circ C$ to $+125^\circ C$; over a Total Ionizing Dose (TID) of 100krad(Si) with an exposure rate of 50-300rad(Si)/s at $25^\circ C$ (ISL70100SEH only); or over a TID of 75krad(Si) with an exposure rate of $<10\text{mrad(Si)/s}$ at $25^\circ C$.**

Parameter	Symbol	Test Conditions	Min ^[1]	Typ ^[2]	Max ^[1]	Unit
Input Specifications						
Input Common-Mode Voltage Range	V_{CM}	Assured by CMRR Test	-0.3	-	40	V
Transconductance	g_m	$V_{SEN} = 25mV$ to 150mV, $V_{RS+} = V_+$ $T_A = +25^\circ C$	1.970	1.988	2.010	$\mu A/mV$
		$V_{SEN} = 25mV$ to 150mV, $V_{RS+} = V_+$, $T_A = -55^\circ C$, $+125^\circ C$	1.960	-	2.020	$\mu A/mV$
		$V_{SEN} = 25mV$ to 150mV, $V_{RS+} = V_+$, $T_A = +25^\circ C$, Post Radiation	1.970	1.988	2.010	$\mu A/mV$
		$V_{SEN} = 25mV$ to 150mV, $V_{RS+} = 0V$ $T_A = +25^\circ C$	1.940	2.011	2.060	$\mu A/mV$
		$V_{SEN} = 25mV$ to 150mV, $V_{RS+} = 0V$, $T_A = -55^\circ C$, $+125^\circ C$	1.930	-	2.070	$\mu A/mV$
		$V_{SEN} = 25mV$ to 150mV, $V_{RS+} = 0V$, $T_A = +25^\circ C$, Post Radiation	1.940	2.011	2.060	$\mu A/mV$

ISL70100SEH, ISL73100SEH Datasheet

Recommended operating conditions, $V_+ = V_{RS+} = 40V$, $V_- = 0V$, $V_{SEN} = (V_{RS+} - V_{RS-})$, $R_{OUT} = 25k\Omega$ and $T_A = +25^\circ C$ unless otherwise specified. **Boldface limits apply across the operating temperature range from $-55^\circ C$ to $+125^\circ C$; over a Total Ionizing Dose (TID) of 100krad(Si) with an exposure rate of 50-300rad(Si)/s at $25^\circ C$ (ISL70100SEH only); or over a TID of 75krad(Si) with an exposure rate of $<10\text{mrad(Si)/s}$ at $25^\circ C$. (Cont.)**

Parameter	Symbol	Test Conditions	Min ^[1]	Typ ^[2]	Max ^[1]	Unit
Input Offset Voltage	V_{OS}	$V_{SEN} = 5mV$ $T_A = +25^\circ C$	-1200	-515	300	μV
		$V_{SEN} = 5mV$ $T_A = -55^\circ C, +125^\circ C$	-1500	-	600	μV
		$V_{SEN} = 5mV$ $T_A = +25^\circ C$, Post Radiation	-1200	-650	300	μV
		$V_{SEN} = 5mV$, $V_{RS+} = 0V$ $T_A = +25^\circ C$	-1100	-365	300	μV
		$V_{SEN} = 5mV$, $V_{RS+} = 0V$ $T_A = -55^\circ C, +125^\circ C$	-1600	-	600	μV
		$V_{SEN} = 5mV$, $V_{RS+} = 0V$ $T_A = +25^\circ C$, Post Radiation	-1100	-635	300	μV
Input Bias Current	I_{BIAS}	$V_{SEN} = 0mV$	-	15	25	μA
		$V_{SEN} = 0mV$, $V_{RS+} = 0V$	-25	-9		μA
Input Offset Current	I_{OS}	$V_{SEN} = 0mV$, $V_{RS+} = 0V$, V_+	-1	-	1	μA
Input Bias Current (Powered Off)	I_{OFF}	$V_+ = V_{SEN} = 0mV$, $V_{RS+} = 40V$	-0.8	-	0.8	μA
Common-Mode Rejection Ratio	CMRR	$V_{SEN} = 5mV$, $V_{RS+} = 2.7V$, $40V$	90	103	-	dB
		$V_{SEN} = 5mV$, $V_{RS+} = 2.7V$, $40V$, $T_A = -55^\circ C, +125^\circ C$	85	-	-	dB
		$V_{SEN} = 5mV$, $V_{RS+} = 2.7V$, $40V$, Post Radiation	90	103	-	dB
		$V_{SEN} = 5mV$, $V_{RS+} = -0.3V$, $40V$	90	106	-	dB
		$V_{SEN} = 5mV$, $V_{RS+} = -0.3V$, $40V$, $T_A = -55^\circ C, +125^\circ C$	85	-	-	dB
		$V_{SEN} = 5mV$, $V_{RS+} = -0.3V$, $40V$, Post Radiation	90	106	-	dB
Output Specifications						
Minimum Output Voltage	V_{OL}	$V_{SEN} = 0mV$	-	-	4	mV
Maximum Output Voltage	V_{OH}	Referred to V_+ , $A_V = 400$, $V_{SEN} = 100mV$	38	38.7	39.4	V
Minimum Guaranteed Linear Output Voltage	OVR	$V_{SEN} = 150mV$, $R_L = OPEN$	38	-	-	V
Maximum Linear Output Current Range	I_{OUT}	$R_{OUT} = 0\Omega$, $T_A = -55^\circ C, +25^\circ C, +125^\circ C$	1200	1600	1800	μA
		$R_{OUT} = 0\Omega$, Post Radiation	1100	1300	1800	μA
Short-Circuit Current	I_{SC}	$V_{RS+} = 40V$, $V_{RS-} = 0V$, $R_{OUT} = 0\Omega$, $T_A = -55^\circ C, +25^\circ C, +125^\circ C$	1200	1600	1800	μA
		$V_{RS+} = 40V$, $V_{RS-} = 0V$, $R_{OUT} = 0\Omega$, Post Radiation	1100	1300	1800	μA
Power Supply Specifications						
Supply Current	I_+	$V_{SEN} = 0mV$, $V_{RS+} = 0V$, V_+	-	280	420	μA
AC Specifications						
500kHz Attenuation	Att_{500kHz}	$V_{SEN} = 50mV$, $C_L = 10pF$, $A_V = 10$, $f_{TEST} = 1kHz$, $500kHz$	-3	-0.21	-	dB
Settling Time	t_S	$V_{SEN} = 5mV$ to $150mV$ (to 1% of final value)	-	0.8	-	μs
Input Step Response Time	t_{RES}	$V_{SEN} = 5mV$ to $150mV$ 50% of input to 50% of output	-	-	1	μs

Recommended operating conditions, $V_+ = V_{RS+} = 40V$, $V_- = 0V$, $V_{SEN} = (V_{RS+} - V_{RS-})$, $R_{OUT} = 25k\Omega$ and $T_A = +25^\circ C$ unless otherwise specified. **Boldface limits apply across the operating temperature range from $-55^\circ C$ to $+125^\circ C$; over a Total Ionizing Dose (TID) of 100krad(Si) with an exposure rate of 50-300rad(Si)/s at $25^\circ C$ (ISL70100SEH only); or over a TID of 75krad(Si) with an exposure rate of $<10\text{mrad(Si)/s}$ at $25^\circ C$.** (Cont.)

Parameter	Symbol	Test Conditions	Min ^[1]	Typ ^[2]	Max ^[1]	Unit
Slew Rate	SR	$V_{SEN} = 5\text{mV to } 150\text{mV}$ ($T_A = +25^\circ C$)	0.50	1.3	2.50	$\text{mA}/\mu\text{s}$
		$V_{SEN} = 5\text{mV to } 150\text{mV}$ ($T_A = +125^\circ C$)	0.50	1.9	2.50	$\text{mA}/\mu\text{s}$
		$V_{SEN} = 5\text{mV to } 150\text{mV}$ ($T_A = -55^\circ C$)	0.45	0.8	2.50	$\text{mA}/\mu\text{s}$
		$V_{SEN} = 5\text{mV to } 150\text{mV}$ ($T_A = +25^\circ C$, Post Rad)	0.50	1.3	2.50	$\text{mA}/\mu\text{s}$

- Parameters with MIN and/or MAX limits are 100% tested at $-55^\circ C$, $+25^\circ C$ and $+125^\circ C$, unless otherwise specified.
- Typical values shown are not guaranteed.

4. Typical Performance Curves

Recommended operating conditions, $V_+ = V_{RS+} = 12V$, $V_- = 0V$, $V_{SEN} = (V_{RS+} - V_{RS-})$, $R_{OUT} = 25k\Omega$ and $T_A = +25^\circ C$, unless otherwise specified.

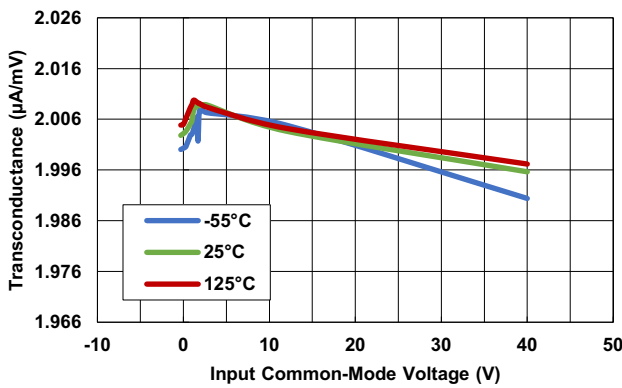

Figure 5. Transconductance, $V_+ = 12V$

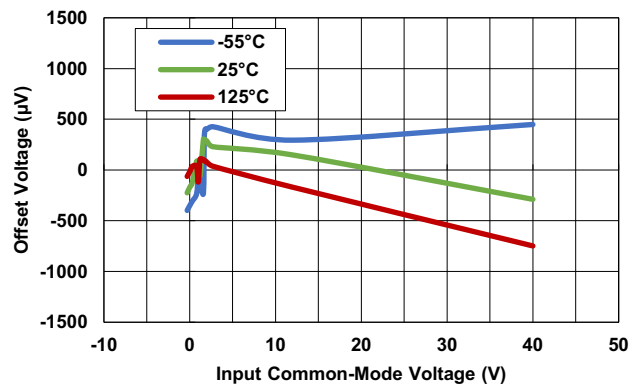

Figure 6. Common-Mode Voltage vs V_{OS} , $V_+ = 12V$

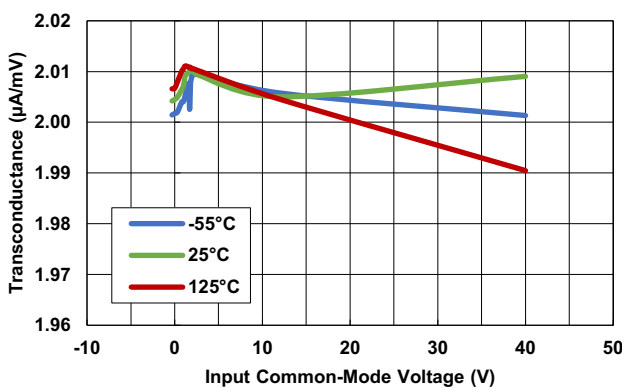

Figure 7. Transconductance, $V_+ = 40V$

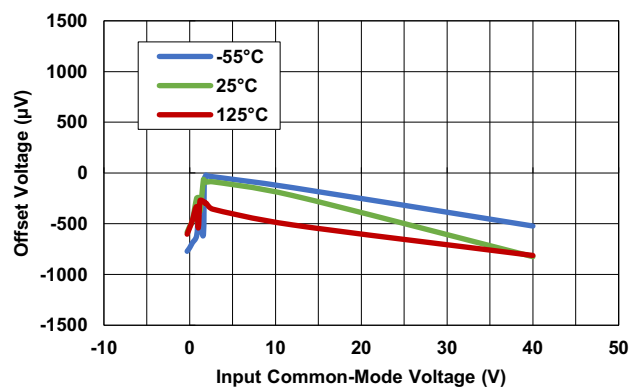

Figure 8. Common-Mode Voltage vs V_{OS} , $V_+ = 40V$

Recommended operating conditions, $V_+ = V_{RS+} = 12V$, $V_- = 0V$, $V_{SEN} = (V_{RS+} - V_{RS-})$, $R_{OUT} = 25k\Omega$ and $T_A = +25^\circ C$, unless otherwise specified. (Cont.)

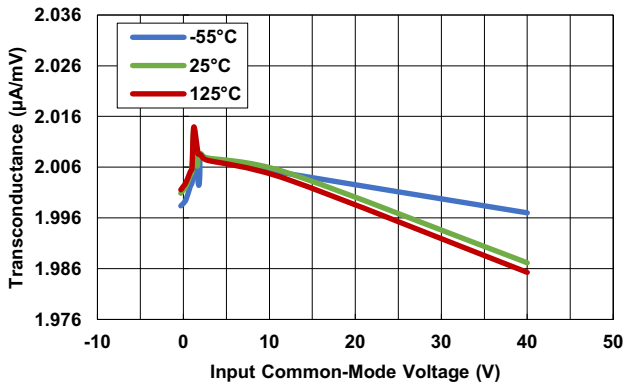

Figure 9. Transconductance, $V_+ = 2.7V$

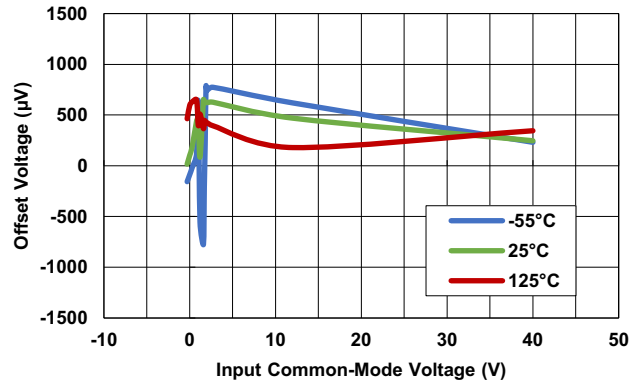

Figure 10. Common-Mode Voltage vs V_{OS} , $V_+ = 2.7V$

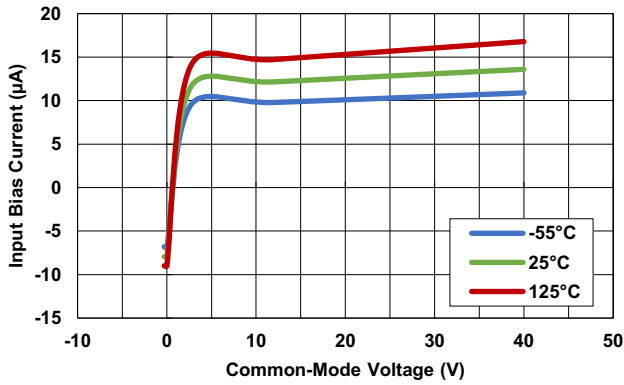

Figure 11. Input Bias Current vs VCM, $V_+ = 12V$

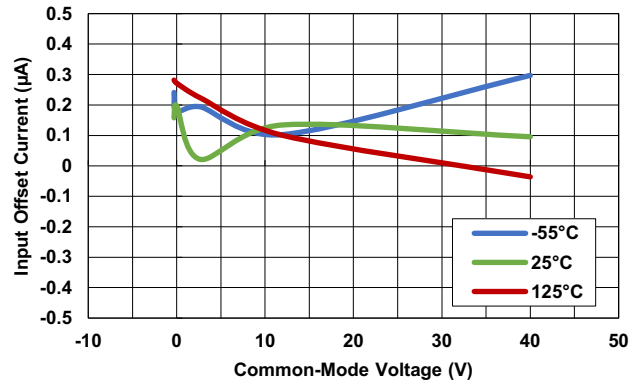

Figure 12. Input Offset Current vs VCM, $V_+ = 12V$

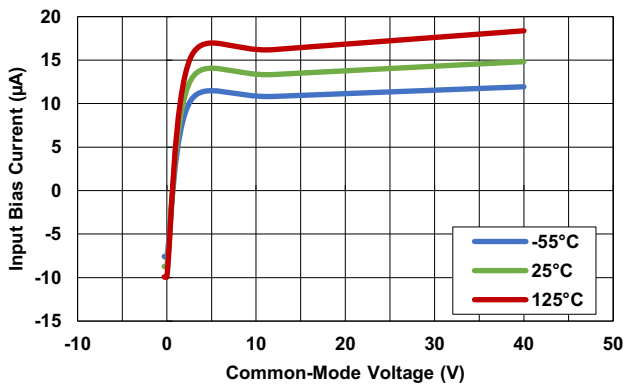

Figure 13. Input Bias Current vs VCM, $V_+ = 40V$

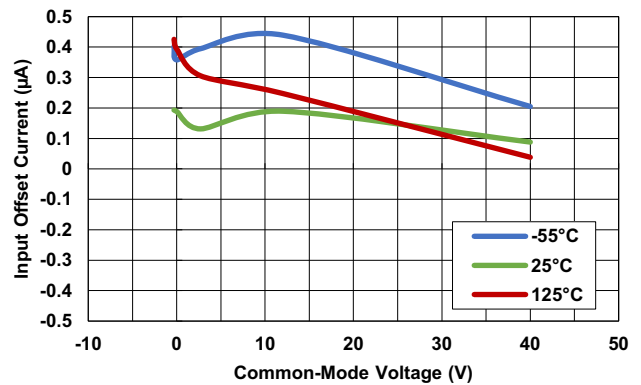

Figure 14. Input Offset Current vs VCM, $V_+ = 40V$

Recommended operating conditions, $V_+ = V_{RS+} = 12V$, $V_- = 0V$, $V_{SEN} = (V_{RS+} - V_{RS-})$, $R_{OUT} = 25k\Omega$ and $T_A = +25^\circ C$, unless otherwise specified. (Cont.)

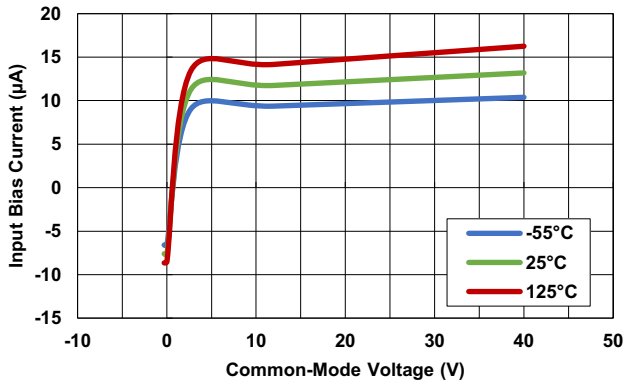

Figure 15. Input Bias Current vs VCM, $V_+ = 2.7V$

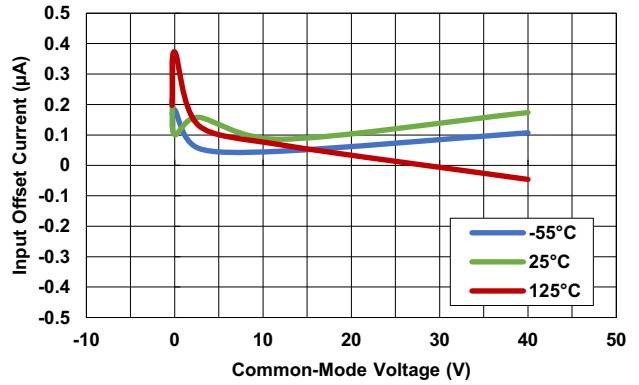

Figure 16. Input Offset Current vs VCM, $V_+ = 2.7V$

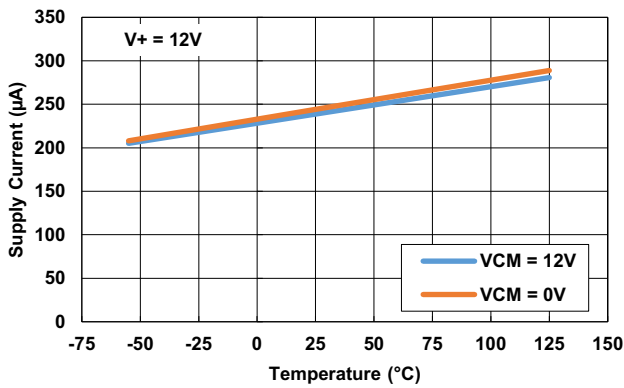

Figure 17. Supply Current, $V_+ = 12V$

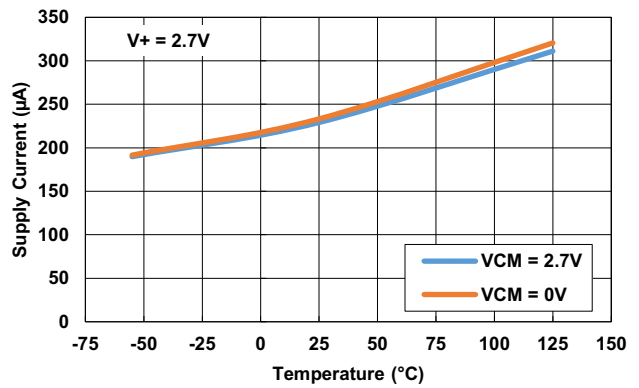

Figure 18. Supply Current, $V_+ = 2.7V$

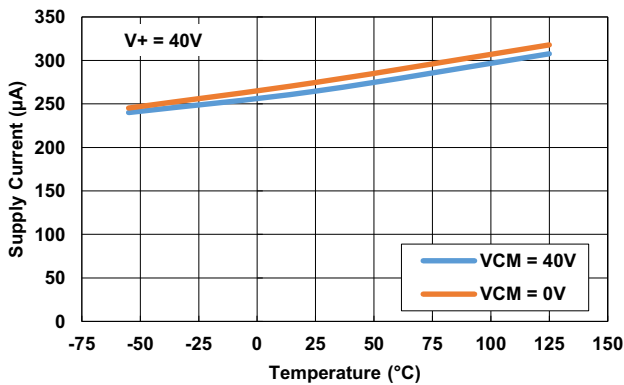

Figure 19. Supply Current, $V_+ = 40V$

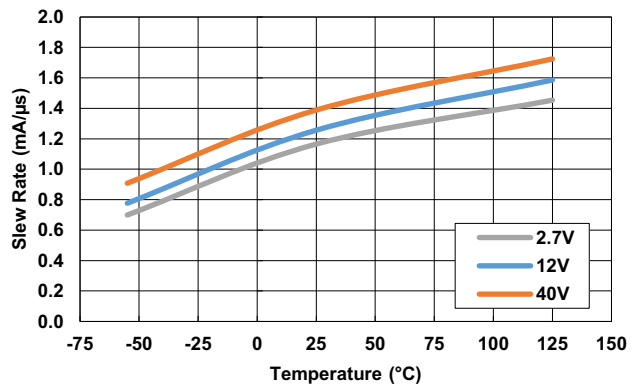

Figure 20. Slew Rate

Recommended operating conditions, $V_+ = V_{RS+} = 12V$, $V_- = 0V$, $V_{SEN} = (V_{RS+} - V_{RS-})$, $R_{OUT} = 25k\Omega$ and $T_A = +25^\circ C$, unless otherwise specified. (Cont.)

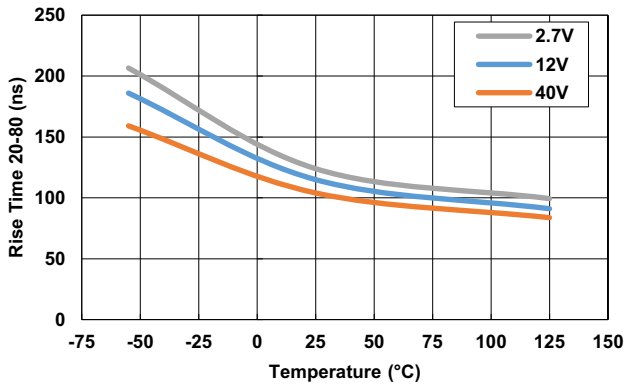

Figure 21. Rise Time

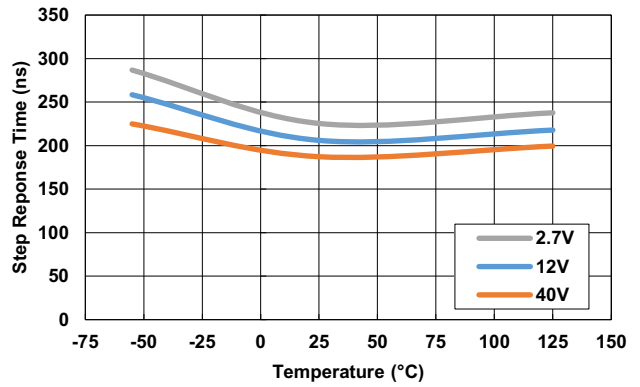

Figure 22. Step Response Time

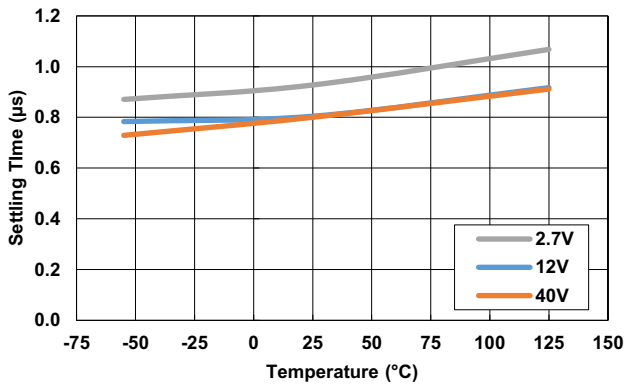

Figure 23. Settling Time

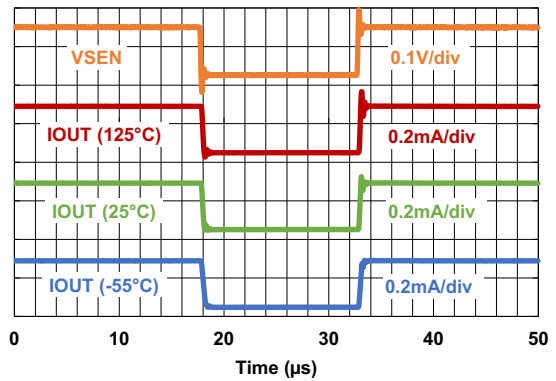

Figure 24. Input Step Response

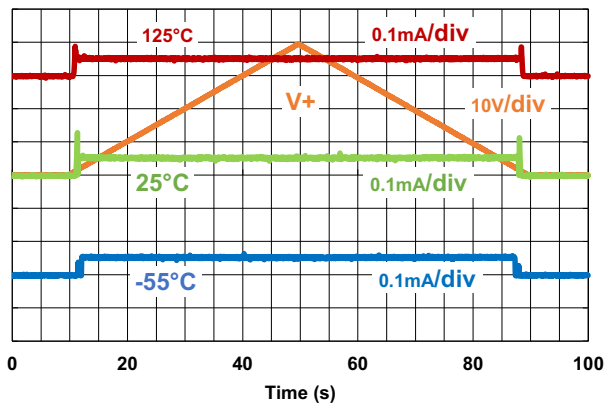

Figure 25. Power Supply Ramp at 1V/s

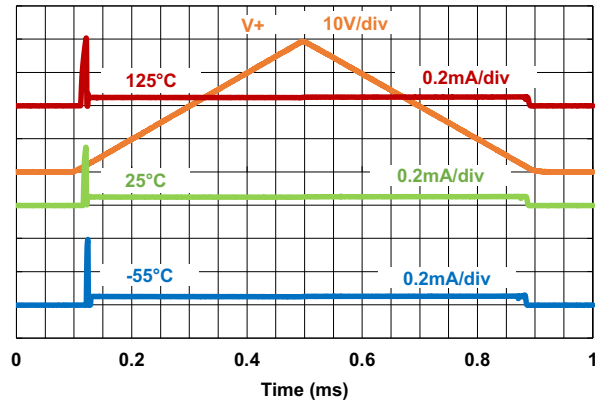

Figure 26. Power Supply Ramp at 1V/10µs

Recommended operating conditions, $V_+ = V_{RS+} = 12V$, $V_- = 0V$, $V_{SEN} = (V_{RS+} - V_{RS-})$, $R_{OUT} = 25k\Omega$ and $T_A = +25^\circ C$, unless otherwise specified. (Cont.)

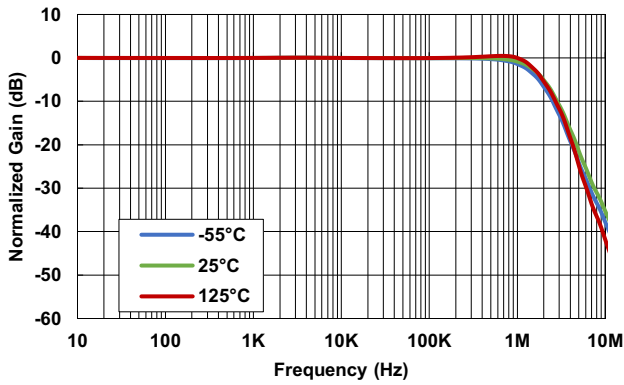

Figure 27. Normalized Gain, $V_+ = 12V$

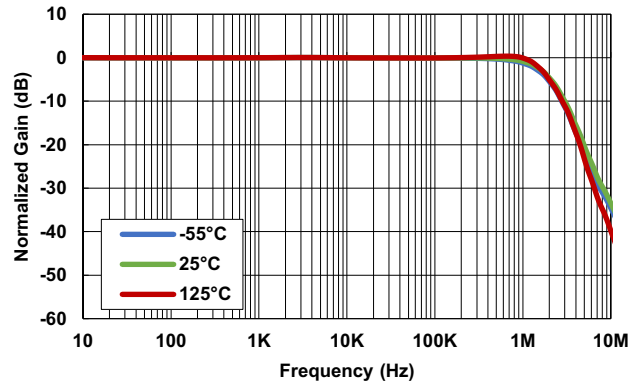

Figure 28. Normalized Gain, $V_+ = 40V$

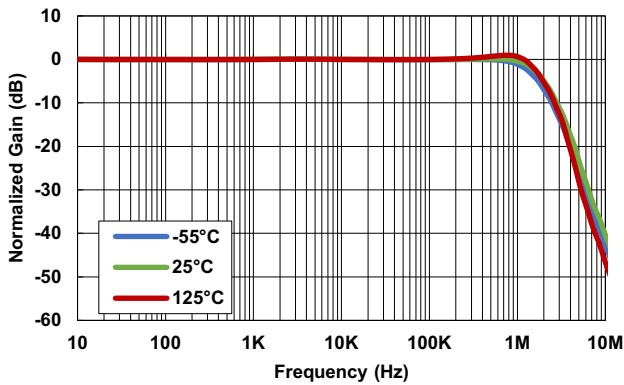

Figure 29. Normalized Gain, $V_+ = 2.7V$

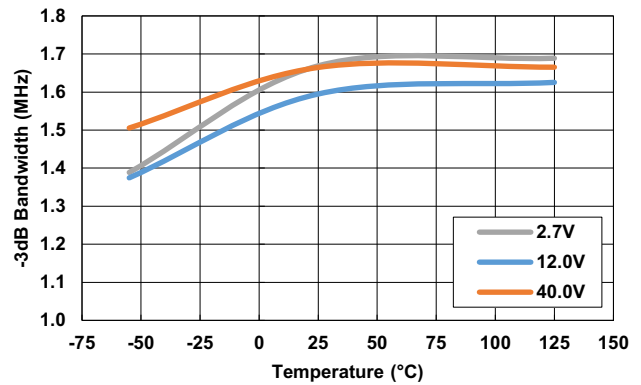

Figure 30. Bandwidth vs Temperature

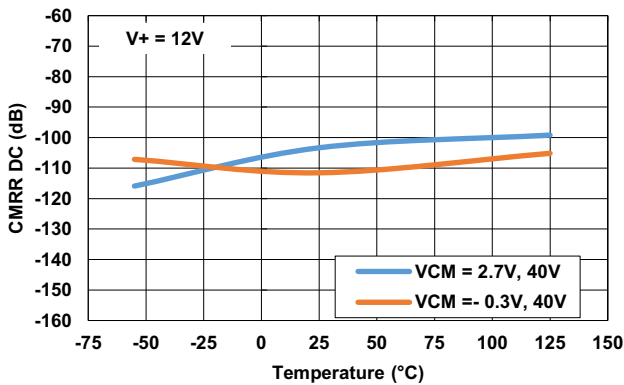

Figure 31. CMRR DC, $V_+ = 12V$

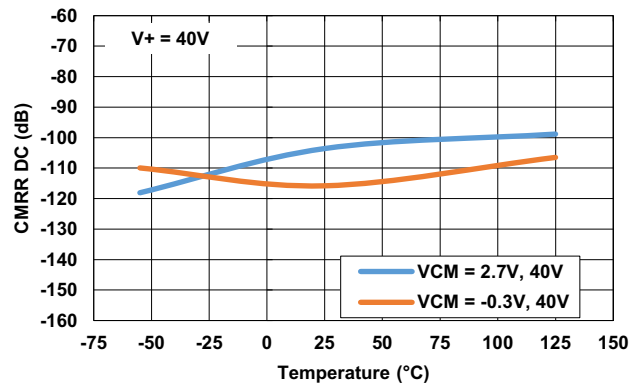

Figure 32. CMRR DC, $V_+ = 40V$

Recommended operating conditions, $V_+ = V_{RS+} = 12V$, $V_- = 0V$, $V_{SEN} = (V_{RS+} - V_{RS-})$, $R_{OUT} = 25k\Omega$ and $T_A = +25^\circ C$, unless otherwise specified. (Cont.)

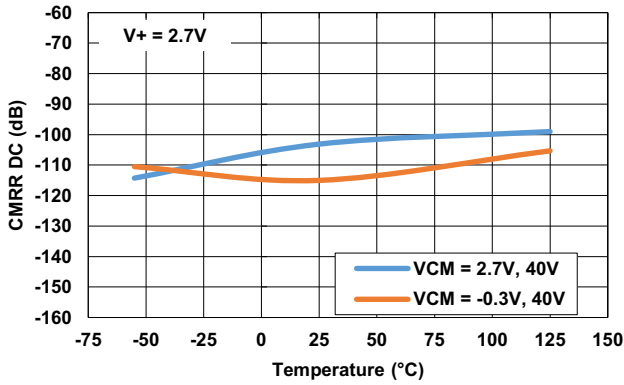

Figure 33. CMRR DC, $V_+ = 2.7V$

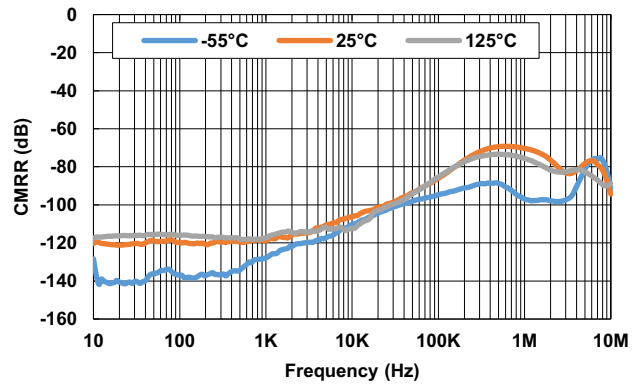

Figure 34. CMRR vs Frequency, $V_+ = 12V$, $V_{CM} = 2.7V$

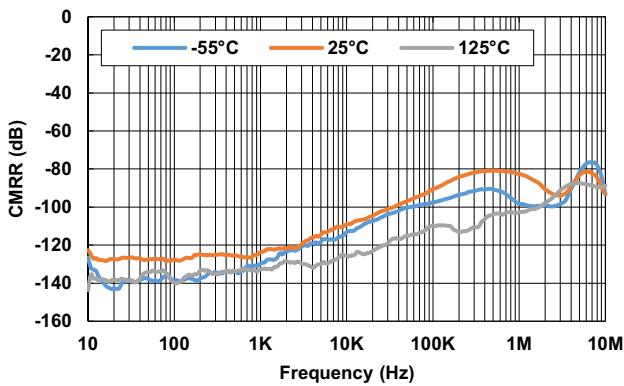

Figure 35. CMRR vs Frequency, $V_+ = 12V$, $V_{CM} = 12V$

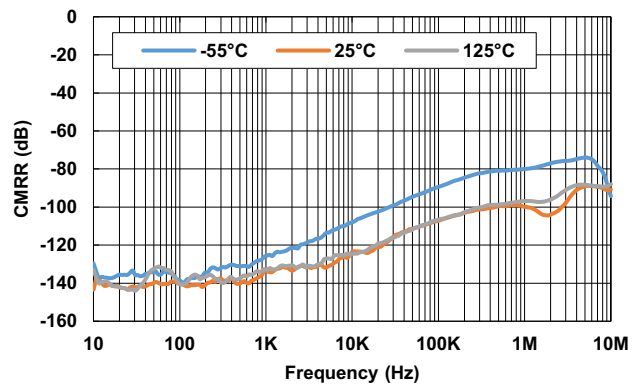

Figure 36. CMRR vs Frequency, $V_+ = 12V$, $V_{CM} = 40V$

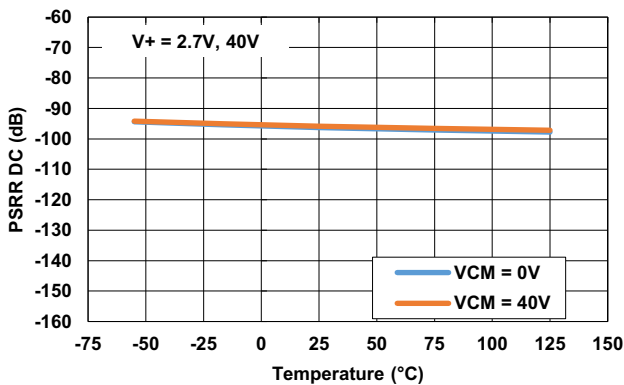

Figure 37. PSRR DC

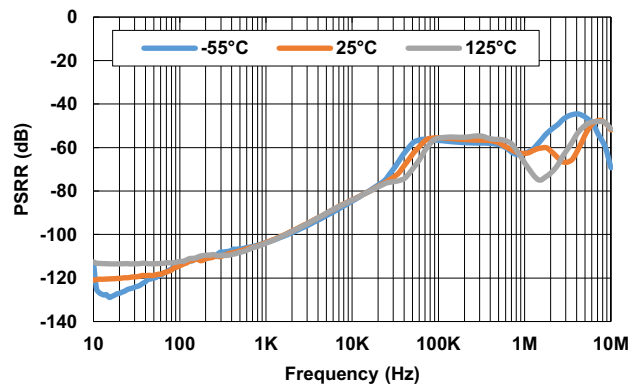

Figure 38. PSRR vs Frequency, $V_+ = 2.7V$, $V_{CM} = 12V$

Recommended operating conditions, $V_+ = V_{RS+} = 12V$, $V_- = 0V$, $V_{SEN} = (V_{RS+} - V_{RS-})$, $R_{OUT} = 25k\Omega$ and $T_A = +25^\circ C$, unless otherwise specified. (Cont.)

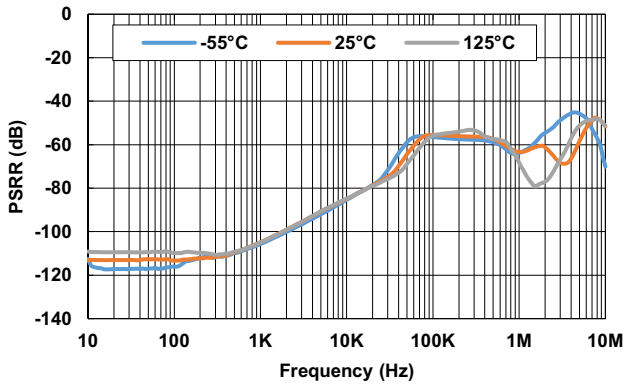

Figure 39. PSRR vs Frequency, $V_+ = 12V$, $V_{CM} = 12V$

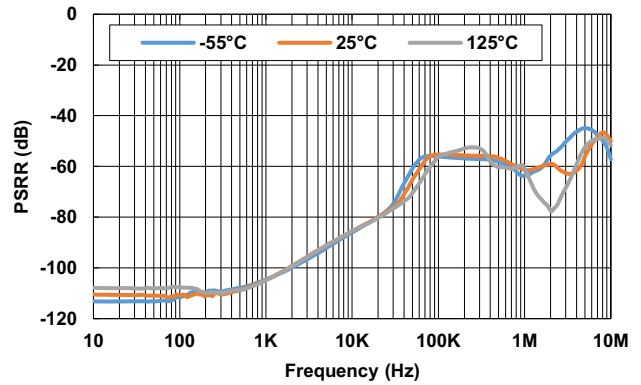

Figure 40. PSRR vs Frequency, $V_+ = 40V$, $V_{CM} = 12V$

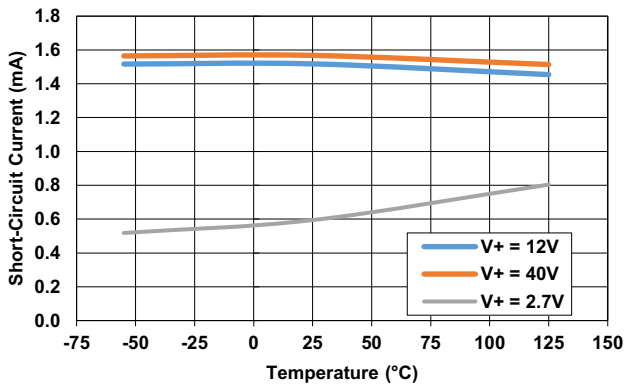

Figure 41. Short-Circuit Current

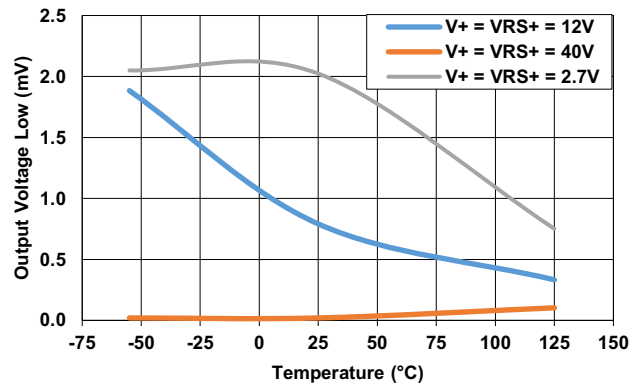

Figure 42. Output Voltage Low

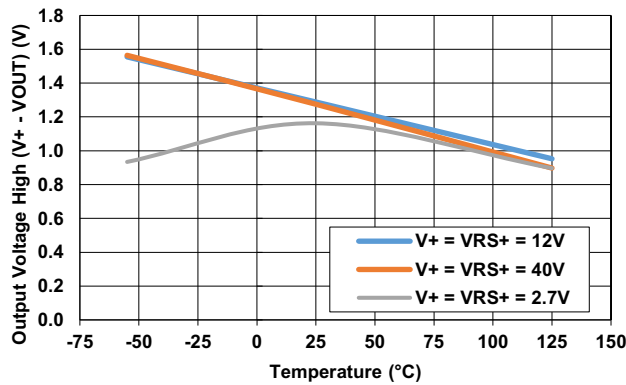

Figure 43. Output Voltage High (Referred to V_+)

5. Functional Description

The ISL70100SEH is a transconductance current sense amplifier with a power supply range of 2.7V to 40V. Its input common-mode range extends from -0.3V to 40V, which makes it ideal for use in both low-side and high-side applications. The input common-mode voltage is independent of the power supply such that the ISL70100SEH can be powered of a 5V rail but sense a 40V common mode. The ISL70100SEH level shifts in the sensed voltage from the sensed power supply to a ground-referenced output. The output gain of the ISL70100SEH can be easily configured with a single resistor on the output. It outputs a current proportional to the input voltage differential and the output resistor sets the voltage gain seen by downstream devices.

The ISL7x100SEH can be driven with bi-polar supplies with the positive voltage on V+ and the negative voltage on V-. The same voltage differentials should still be between 2.7V and 40V from V+ to V-. The output of the amplifier is referenced to V- so any downstream device will need to be able to handle a bipolar input.

5.1 Output Signal Range

The output range of these amplifiers is limited on the low end by the input offset voltage and the saturation voltage of the output transistors on the top end. The maximum voltage is always about 2V below the voltage on V+. If the application calls for a large gain, the supply voltage may need to be increased to accommodate the full output voltage range. For example, if the supply voltage is 2.7V, the output can only get up to 0.7V before the output is saturated; this sets the maximum gain with 2.7V supply to 4.67 with a maximum sensing voltage of 150mV. If the sensing voltage range is reduced, higher gains can be used.

$$(EQ. 1) \quad A_{CSA(MAX)} = \frac{V_{OH}}{V_{SEN(MAX)}}$$

where:

- $A_{CSA(MAX)}$ is the maximum output gain given the maximum input differential
- V_{OH} is the maximum output high voltage from the electrical specifications table in volts
- $V_{SEN(MAX)}$ is the maximum input differential that the application calls for in volts

Typically, the output of the ISL7x100SEH is connected to the input of an Analog-to-Digital Converter (ADC), which has limited input voltage ranges. Ensure that the output voltage ($I_{OUT(MAX)} \cdot R_{OUT}$) does not exceed the input voltage range of the downstream ADC.

5.2 Input Common-Mode Range

The input common-mode range of the ISL70100SEH and ISL73100SEH ranges from -0.3V to 40V regardless of the voltage on V+. The electrical specifications table shows that the offset voltage of these amplifiers changes very slightly over the full common-mode range. The inputs are also capable of either RS+ or RS- dropping to 0V without damaging the amplifier, this is particularly useful in monitoring protection fuse circuits where the output goes to the positive rail if the fuse is blown. If the inputs differential is reversed (RS- goes above RS+), the output does not phase invert, it will simply remain at the output low voltage specified in the electrical specifications table.

5.3 Crossover Region

The ISL7x100SEH accomplishes the wide input common-mode range using multiple input paths that are selected based on the common-mode voltage. The transition point between the high-side and low-side is typically 1.7V but can range from 1.5V to 2.0V across temperature. When the common-mode voltage has reached the transition point, there is a soft switchover from the low-side to the high-side.

5.4 Sources of Error

5.4.1 Input Impedance of Downstream Devices

The value of the output resistance is not critical if the circuit that is being driven has a high input impedance. If the driven circuit has a low input impedance, the accuracy of V_{OUT} is reduced. Using an example where the input impedance is 100 times larger than the output resistance. It can be seen that the accuracy drops by 1%.

$$(EQ. 2) \quad V_{OUT} = I_{OUT} \times \frac{R_{OUT} \times R_{IN}}{R_{OUT} + R_{IN}} = I_{OUT} \times \frac{100}{101} = I_{OUT} \times R_{OUT} \times 0.99$$

where:

- V_{OUT} is the output voltage in volts
- I_{OUT} is the output current in amps
- R_{OUT} is output resistance loading the output of the ISL7x100SEH in ohms
- R_{IN} is the input impedance of the downstream device in ohms

5.4.2 Input Offset Voltage

The dynamic range of the ISL7x100SEH is inversely proportional to the input offset voltage. The dynamic range can be thought of as the maximum sense voltage divided by V_{OS} . These amplifiers have an offset voltage of 10 μ V typically. The electrical specification table shows how the offset voltage can vary across various operating points.

5.4.3 Input Bias and Offset Current

A typical current sense amplifier has the ability to change its transconductance by changing the input resistors. In this case, the input bias currents and offset currents can induce more error on top of the offset voltage. The ISL7x100SEH gets around this by internalizing these input resistors and trimming out the error associated with them during production.

5.4.4 Sensed Current Error

The effective current error can be determined with [Equation 3](#). It shows the amount of current that the current-sense amplifier is blind to.

$$(EQ. 3) \quad I_{ERROR} = \frac{V_{OS}}{R_{SENSE}}$$

where:

- V_{OS} is the offset voltage in μ V.
- R_{SENSE} is the sense resistor in m Ω .
- I_{ERROR} is the current error in mA.

The R_{SENSE} can be increased to lower the current error, but this reduces the maximum current that can be sensed and increases power dissipation. Careful consideration must be made to balance power dissipation and accuracy.

6. Applications Information

6.1 Selection of the External Current-Sense Resistor

To pick the current-sense resistor value, a decision has to be made between power dissipation and measurement accuracy. As a general rule for all applications, the sense resistor should be as small as possible while still providing adequate input dynamic range across the operating range. The minimum accurately sensed input voltage is primarily limited by the offset voltage of the ISL70100SEH.

The sense resistor value can be calculated once the maximum sensed load current is determined. The maximum recommended sense voltage for the ISL70100SEH is 150mV, so dividing that by the maximum load current provides the sense resistor value.

$$(EQ. 4) \quad R_{SENSE} = \frac{150\text{mV}}{I_{OUT(MAX)}}$$

where:

- R_{SENSE} is the sense resistor in m Ω .
- $I_{OUT(MAX)}$ is the maximum expected load current to be sensed in amps.

6.2 Gain Setting

The gain on the ISL70100SEH can be adjusted using a single resistor on the output. The ISL70100SEH outputs 2 μ A for every 1mV of differential across the inputs. Equation 5 can be used to calculate the output load resistance to get a specific gain:

$$(EQ. 5) \quad R_{OUT} = \frac{A_{CSA}}{g_m}$$

where:

- R_{OUT} is the output load resistance in k Ω .
- A_{CSA} is desired voltage gain.
- g_m is the transconductance of the ISL70100SEH which is 2 μ A/mV (typical).

6.3 Selection of Output Resistor

The output signal is a current conducted through the output resistor to generate a voltage. With a maximum input range of 150mV, the output current is 300 μ A. The voltage gain should be determined based on the input voltage range of the downstream device. For example, if there is a 5V ADC on the output of the ISL7x100SEH, the output resistance should be 16.6k Ω to ensure that V_{OUT} stays under 5V. This also means that the minimum power supply voltage has to be 7V to achieve 5V on the output. Renesas recommends using resistors that have a low temperature coefficient on the output as it adds error to the measurement.

6.4 Output Filtering

Because the output of these amplifiers is a current source, filtering is straight forward. A capacitor can be placed in parallel to the output resistance to create a pole based on Equation 6:

$$(EQ. 6) \quad f_{-3dB} = \frac{1}{2 \times \pi \times R_{OUT} \times C_{OUT}}$$

where:

- f_{-3dB} is frequency location of the pole in hertz
- R_{OUT} is the output resistance in ohms
- C_{OUT} is the output capacitance in parallel with R_{OUT} in farads

6.5 Response Time

The ISL7x100SEH is designed to provide fast response time for circuit protection or signal transmission. The delay and speed of the response depend on the starting point of the step. If the sensed current is very low (near zero) before the transient, there may be an increased delay time to see the output react. If fast reaction times are required, increase the sense resistance such that there are a few millivolts (1-5mV) of differential across the inputs under the lowest current condition. The higher the differential is for the lowest current condition, the faster the response time is, but that results in increased DC power losses.

Figures 44 and 45 show the step response difference from starting with a 0mV differential versus starting with a 25mV differential. For most applications the 40-50ns faster reaction time may not warrant the resulting power loss.

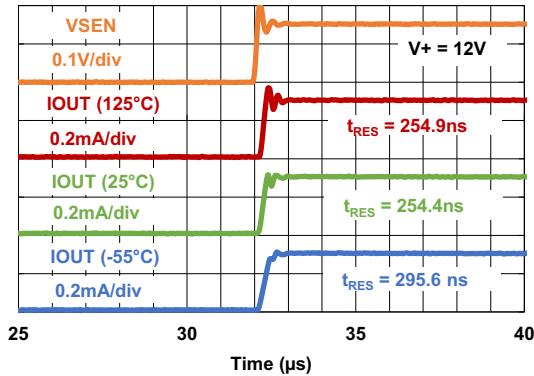

Figure 44. 0mV to 150mV Step Response

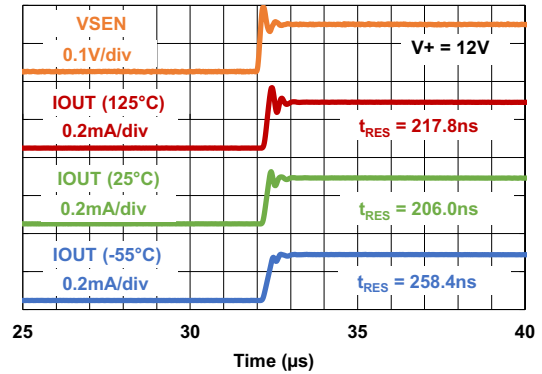

Figure 45. 25mV to 150mV Step Response

7. Die Characteristics

Table 1. Die and Assembly Related Information

Die Information	
Dimensions	2413μm x 3302μm (95 mils x 130 mils) Thickness: 483μm ± 25μm (19 mils ± 1 mil)
Interface Materials	
Glassivation	Type: 15kÅ Nitrox
Top Metallization	Type: 30kÅ AlCu (99.5%/0.5%)
Backside Finish	Silicon
Process	PR40
Assembly Information	
Substrate Potential	Floating
Additional Information	
Worst Case Current Density	<2 x 10 ⁵ A/cm ²
Transistor Count	560
Weight of Packaged Device	0.3916 grams
Lid Characteristics	Finish: Gold Potential: Tied to package Pin 6 (Lid)

7.1 Metallization Mask Layout

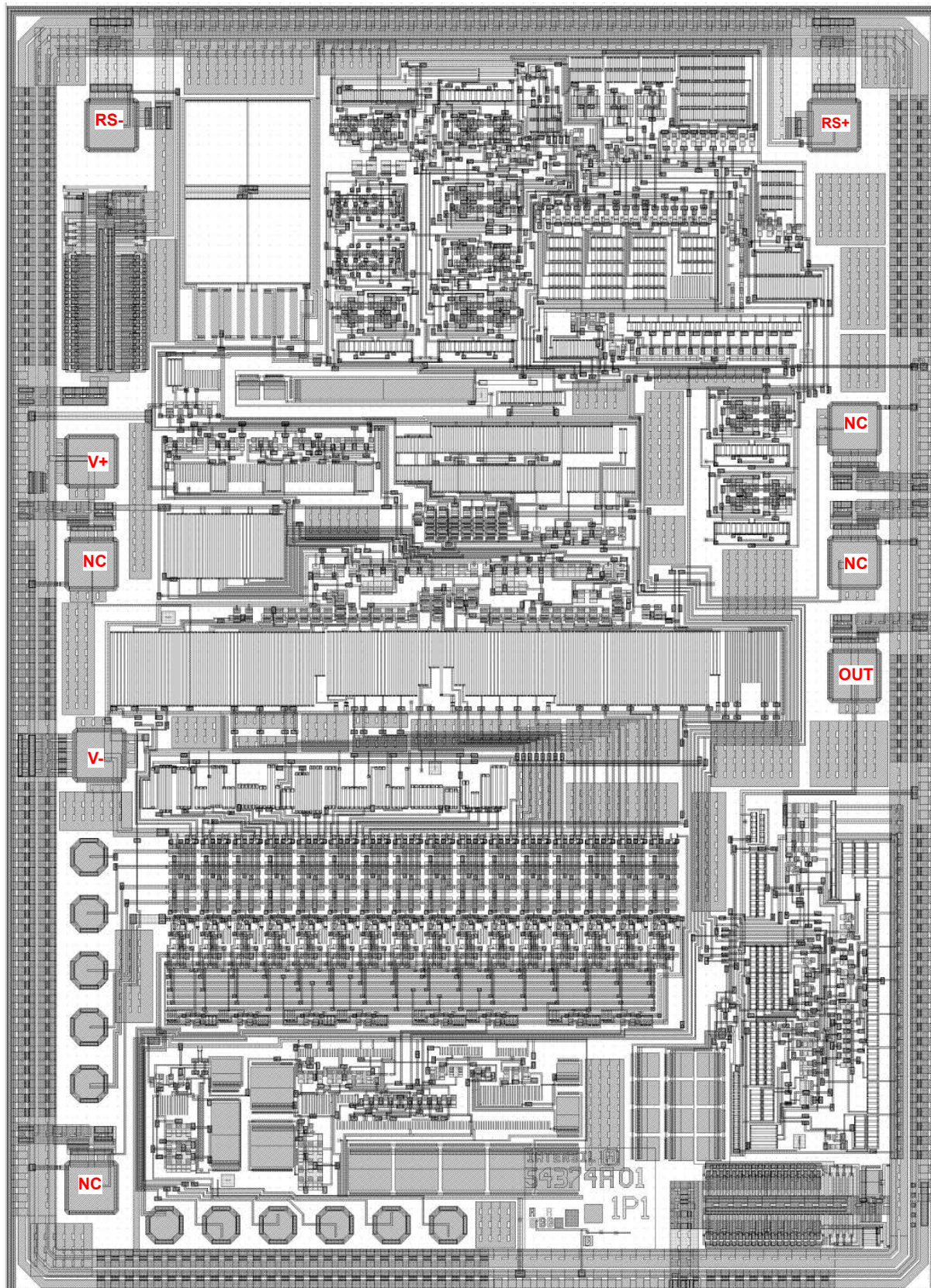

Table 2. Die Layout X-Y Coordinates^[1]

Pad Name	ΔX (μm)	ΔY (μm)	X (μm)	Y (μm)
RS-	110	110	-891.0	1302.5
V+	110	110	-941.0	472.5
NC	110	110	-941.0	219.5
V-	110	110	-921.5	-252.5
NC	110	110	-941.0	-1320.5
OUT	110	110	941.0	-57.0
NC	110	110	941.0	223.0
NC	110	110	941.0	553.0
RS+	110	110	891.0	1302.5

1. Origin of coordinates is the center of the die.

8. Package Outline Drawing

The package outline drawing is located at the end of this document and is accessible from the Renesas website. The package information is the most current data available and is subject to change without revision of this document.

9. Ordering Information

Ordering SMD Number ^[1]	Part Number ^[2]	Radiation Hardness (Total Ionizing Dose)	Temp Range ($^{\circ}\text{C}$)	Package (RoHS Compliant)	Package Drawing
5962R2021201VXC	ISL70100SEHVF	HDR to 100krad(Si), LDR to 75krad(Si)	-55 to +125	10 Ld FP	K10.A
5962R2021201V9A	ISL70100SEHVX ^[3]		-55 to +125	Die	N/A
5962L2021202VXC	ISL73100SEHVF	LDR to 75krad(Si)	-55 to +125	10 Ld FP	K10.A
5962L2021202V9A	ISL73100SEHVX ^[3]		-55 to +125	Die	N/A
N/A	ISL70100SEHF/PROTO ^[4]	N/A	-55 to +125	10 Ld FP	K10.A
N/A	ISL70100SEHX/SAMPLE ^{[3][4]}	N/A	-55 to +125	Die	N/A
N/A	ISL73100SEHF/PROTO ^[4]	N/A	-55 to +125	10 Ld FP	K10.A
N/A	ISL73100SEHX/SAMPLE ^{[3][4]}	N/A	-55 to +125	Die	N/A
N/A	ISL73100SEHEV1Z ^[5]	Evaluation Board with ISL73100SEHF/PROTO			

- Specifications for Rad Hard QML devices are controlled by the Defense Logistics Agency Land and Maritime (DLA). The SMD numbers listed must be used when ordering.
- These Pb-free Hermetic packaged products employ 100% Au plate - e4 termination finish, which is RoHS compliant and compatible with both SnPb and Pb-free soldering operations.
- Die product tested at $T_A = +25^{\circ}\text{C}$. The wafer probe test includes functional and parametric testing sufficient to make the die capable of meeting the electrical performance outlined in [Electrical Specifications](#).
- The /PROTO and /SAMPLE are not rated or certified for Total Ionizing Dose (TID) or Single Event Effect (SEE) immunity. These parts are intended for engineering evaluation purposes only. The /PROTO parts meet the electrical limits and conditions across temperature specified in the DLA SMD and are in the same form and fit as the qualified device. The /SAMPLE parts are capable of meeting the electrical limits and conditions specified in the DLA SMD. The /SAMPLE parts do not receive 100% screening across temperature to the DLA SMD electrical limits. These part types do not come with a Certificate of Conformance because they are not DLA qualified devices.
- The evaluation board uses the /PROTO parts. The /PROTO parts are not rated or certified for Total Ionizing Dose (TID) or Single Event Effect (SEE) immunity.

10. Revision History

Rev.	Date	Description
1.02	May 8, 2026	<ul style="list-style-type: none">▪ Applied the latest template.▪ Updated Equation 1 and the information below it.▪ Added ECAD section.
1.01	Jul 10, 2020	Updated the Maximum Input Voltage Differential minimum specifications in the Absolute Maximum Ratings section to align with SMD.
1.00	Jun 3, 2020	Initial release

A. ECAD Design Information

This information supports the development of the PCB ECAD model for this device. It is intended to be used by PCB designers.

A.1 Part Number Indexing

Orderable Part Number	Number of Pins	Package Type	Package Code/POD Number
ISL70100SEHVF	10	Flatpack	K10.A
ISL73100SEHVF	10	Flatpack	K10.A

A.2 Symbol Pin Information

A.2.1 10-Flatpack

Pin Number	Primary Pin Name	Primary Electrical Type	Alternate Pin Name(s)
1	RS-	Input	-
2	V+	Power	-
3	DNC	Passive	-
4	V-	Power	-
5	DNC	Passive	-
6	LID	Power	-
7	OUT	Output	-
8	DNC	Passive	-
9	DNC	Passive	-
10	RS+	Input	-

A.3 Symbol Parameters

Orderable Part Number	Qualification	Radiation Qualification	LDR	Mounting Type	RoHS	Min Operating Temperature	Max Operating Temperature	Min Input Voltage	Max Input Voltage	Min Common Mode Input Voltage	Max Common Mode Input Voltage	Min Input Differential Voltage	Max Input Differential Voltage	Transconductance Accuracy 25°C	Transconductance Accuracy -55°C, 125°C
ISL70100SEHVF	Space	QML Class P	75 krad(Si)	SMD	Compliant	-55 °C	125 °C	2.7 V	40 V	-0.3 V	40 V	0 mV	150 mV	1 %	1.5 %
ISL73100SEHVF	Space	QML Class P	75 krad(Si)	SMD	Compliant	-55 °C	125 °C	2.7 V	40 V	-0.3 V	40 V	0 mV	150 mV	1 %	1.5 %

A.4 Footprint Design Information

Follow the POD drawing for footprint generation of the 10 Ld Flatpack (K10.A).

Ceramic Metal Seal Flatpack Packages (Flatpack)

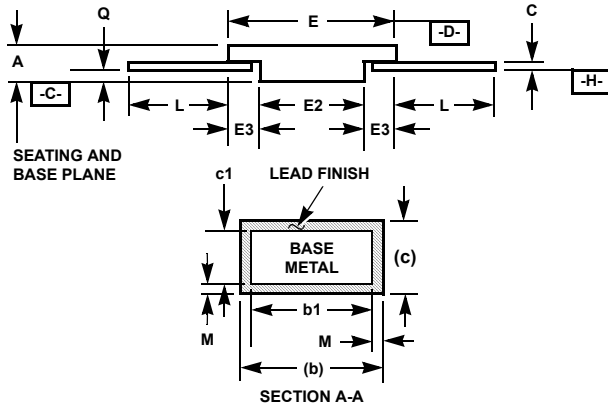
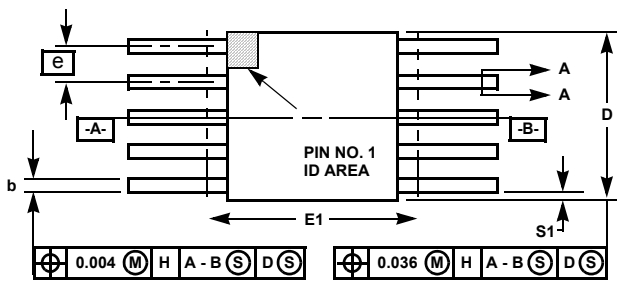

**K10.A MIL-STD-1835 CDFP3-F10 (F-4A, CONFIGURATION B)
10 LEAD CERAMIC METAL SEAL FLATPACK PACKAGE**

SYMBOL	INCHES		MILLIMETERS		NOTES
	MIN	MAX	MIN	MAX	
A	0.045	0.115	1.14	2.92	-
b	0.015	0.022	0.38	0.56	-
b1	0.015	0.019	0.38	0.48	-
c	0.004	0.009	0.10	0.23	-
c1	0.004	0.006	0.10	0.15	-
D	-	0.290	-	7.37	3
E	0.240	0.260	6.10	6.60	-
E1	-	0.280	-	7.11	3
E2	0.125	-	3.18	-	-
E3	0.030	-	0.76	-	7
e	0.050 BSC		1.27 BSC		-
k	0.008	0.015	0.20	0.38	2
L	0.250	0.370	6.35	9.40	-
Q	0.026	0.045	0.66	1.14	8
S1	0.005	-	0.13	-	6
M	-	0.0015	-	0.04	-
N	10		10		-

Rev. 0 3/07

NOTES:

1. Index area: A notch or a pin one identification mark shall be located adjacent to pin one and shall be located within the shaded area shown. The manufacturer's identification shall not be used as a pin one identification mark. Alternately, a tab (dimension k) may be used to identify pin one.
2. If a pin one identification mark is used in addition to a tab, the limits of dimension k do not apply.
3. This dimension allows for off-center lid, meniscus, and glass overrun.
4. Dimensions b1 and c1 apply to lead base metal only. Dimension M applies to lead plating and finish thickness. The maximum limits of lead dimensions b and c or M shall be measured at the centroid of the finished lead surfaces, when solder dip or tin plate lead finish is applied.
5. N is the maximum number of terminal positions.
6. Measure dimension S1 at all four corners.
7. For bottom-brazed lead packages, no organic or polymeric materials shall be molded to the bottom of the package to cover the leads.
8. Dimension Q shall be measured at the point of exit (beyond the meniscus) of the lead from the body. Dimension Q minimum shall be reduced by 0.0015 inch (0.038mm) maximum when solder dip lead finish is applied.
9. Dimensioning and tolerancing per ANSI Y14.5M - 1982.
10. Controlling dimension: INCH.

IMPORTANT NOTICE AND DISCLAIMER

RENESAS ELECTRONICS CORPORATION AND ITS SUBSIDIARIES (“RENESAS”) PROVIDES TECHNICAL SPECIFICATIONS AND RELIABILITY DATA (INCLUDING DATASHEETS), DESIGN RESOURCES (INCLUDING REFERENCE DESIGNS), APPLICATION OR OTHER DESIGN ADVICE, WEB TOOLS, SAFETY INFORMATION, AND OTHER RESOURCES “AS IS” AND WITH ALL FAULTS, AND DISCLAIMS ALL WARRANTIES, EXPRESS OR IMPLIED, INCLUDING, WITHOUT LIMITATION, ANY IMPLIED WARRANTIES OF MERCHANTABILITY, FITNESS FOR A PARTICULAR PURPOSE, OR NON-INFRINGEMENT OF THIRD-PARTY INTELLECTUAL PROPERTY RIGHTS.

These resources are intended for developers who are designing with Renesas products. You are solely responsible for (1) selecting the appropriate products for your application, (2) designing, validating, and testing your application, and (3) ensuring your application meets applicable standards, and any other safety, security, or other requirements. These resources are subject to change without notice. Renesas grants you permission to use these resources only to develop an application that uses Renesas products. Other reproduction or use of these resources is strictly prohibited. No license is granted to any other Renesas intellectual property or to any third-party intellectual property. Renesas disclaims responsibility for, and you will fully indemnify Renesas and its representatives against, any claims, damages, costs, losses, or liabilities arising from your use of these resources. Renesas' products are provided only subject to Renesas' Terms and Conditions of Sale or other applicable terms agreed to in writing. No use of any Renesas resources expands or otherwise alters any applicable warranties or warranty disclaimers for these products.

(Disclaimer Rev.1.01)

Corporate Headquarters

TOYOSU FORESIA, 3-2-24 Toyosu,
Koto-ku, Tokyo 135-0061, Japan
www.renesas.com

Trademarks

Renesas and the Renesas logo are trademarks of Renesas Electronics Corporation. All trademarks and registered trademarks are the property of their respective owners.

Contact Information

For further information on a product, technology, the most up-to-date version of a document, or your nearest sales office, please visit www.renesas.com/contact-us/.