

GENERAL DESCRIPTION



The M690SDM is a single frequency/single output SAW-based VCSO for low-jitter clock generation. The M690SDM incorporates an analog X2 frequency multiplier to provide an output

frequency that is twice that of the fundamental VCSO frequency.

FEATURES

- ◆ Integrated SAW device
- ◆ Low phase jitter: 250fs rms typical for the M690SDM (20kHz to 20MHz)
- ◆ Output frequency: 1747 MHz Typ. (Specify center frequency at time of order)
- ◆ Single-ended RF Output
- ◆ Single +5V power supply
- ◆ 13 x 20mm SMT (surface mount) package
- ◆ Pb-free / Compliant to EC RoHS Directive (RoHS 5/6)

PIN ASSIGNMENT (13 x 20mm SMT)

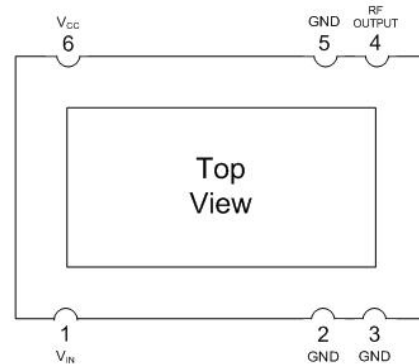

Figure 1: Pin Assignment

Sample of Available Output Frequencies

VCSO Center Frequencies ¹ (MHz)	Output Frequency Code
1747.623000	R01
1747.030837	R02
1748.366885	R03
1748.793733	R04

Table 1: Sample of Available Output Frequencies

Note 1: Specify VCSO center frequency at time of order. Other frequencies available upon request.

BLOCK DIAGRAM

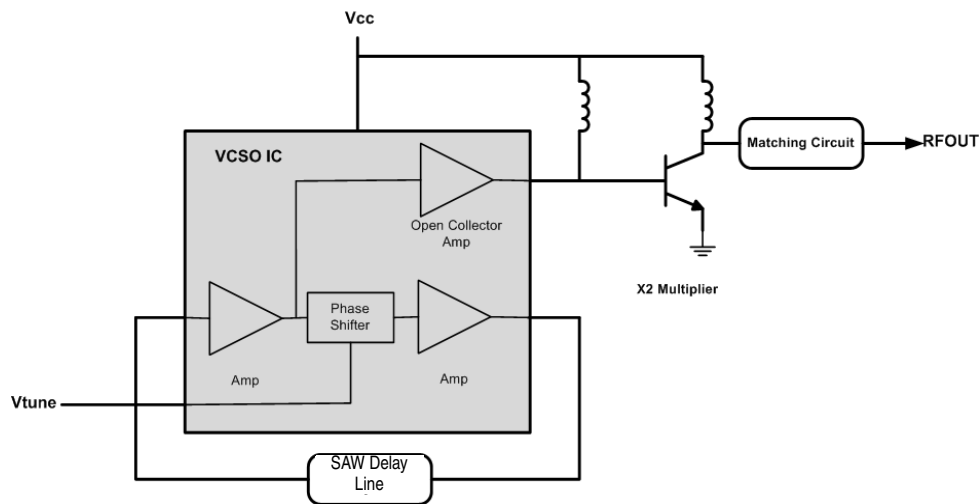

Figure 2: Block Diagram

PIN DESCRIPTIONS

Number	Name	I/O	Configuration	Description
1	VIN	Input		Frequency control input.
2, 3, 5	GND	Ground		Power supply ground connection.
4	RF OUTPUT	Output	No internal terminator	Clock output. Single-ended.
6	VCC	Power		Power supply connection, connect to +5.0 V.

Table 2: Pin Descriptions

ABSOLUTE MAXIMUM RATINGS¹

Symbol	Parameter	Rating	Unit
V_I	Inputs	-0.5 to $V_{CC} + 0.5$	V
V_O	Outputs	-0.5 to $V_{CC} + 0.5$	V
V_{CC}	Power Supply Voltage	6.0	V
T_S	Storage Temperature	-55 to +125	°C

Table 3: Absolute Maximum Ratings

Note 1: Stresses beyond those listed under Absolute Maximum Ratings may cause permanent damage to the device. These ratings are stress specifications only. Functional operation of product at these conditions or any conditions beyond those listed in Recommended Conditions of Operation, DC Characteristics, or AC Characteristics is not implied. Exposure to absolute maximum rating conditions for extended periods may affect product reliability.

RECOMMENDED CONDITIONS OF OPERATION

Symbol	Parameter	Min	Typ	Max	Unit
V_{CC}	Positive Supply Voltage	4.875	5.0	5.125	V
T_{CASE}	Operating Temperature	+10		+85	°C

Table 4: Recommended Conditions of Operation

ELECTRICAL SPECIFICATIONS

DC Characteristics for M690SDM

Unless stated otherwise, $V_{CC} = 5.0 \text{ Volts} \pm 2.5\%$, $T_{CASE} = 10 \text{ to } 85^\circ\text{C}$, VCSO Frequency = 1747.623000, Output terminated with 50Ω

	Symbol	Parameter	Pin	Min	Typ	Max	Unit
Power Supply	V_{CC}	Positive Supply Voltage	VCC	4.875	5.0	5.125	V
	I_{CC}	Power Supply Current			145	165	mA
Control Voltage	V_{IN}	Input Control Voltage Range	VIN	0		3.3	V
		V_{IN} Input Impedence		20			kΩ

Table 5: DC Characteristics for M690SDM

AC Characteristics for M690SDM

Unless stated otherwise, $V_{CC} = 5.0 \text{ Volts} \pm 2.5\%$, $T_{CASE} = 10 \text{ to } 85^\circ\text{C}$, VCSO Frequency = 1747.623000, Outputs terminated with 50Ω

	Symbol	Parameter	Pin	Min	Typ	Max	Unit	Notes
Control Voltage	V_{IN}	Modulation Bandwidth	VIN		500		kHz	
Output	RF OUTPUT	Output Center Frequency Range		1500		2100	MHz	
	P_{OUTPUT}	Output Power		7.5	10.0	12.0	dBm	50Ω load; AC Coupled
	T_{RANGE}	Tuning Range			1000		ppm	
	APR	Absolute (Guaranteed) Pull-Range ¹		±100			ppm	
	f_{STAB}	Frequency Stability			300		ppm p-p	10°C to 85°C
		Power Supply Pushing		-32		32	ppm	$V_{CC} = 5.0V \pm 2.5V$
	L_{IN}	Tuning Linearity		-8		8	%	Deviation from best Linear fit
	K_{VCO}	VCO Gain	@ 1747.623000MHz		340		ppm/V	
		Harmonic Spurious				-30	dBc	
		Sub-harmonic Spurious				-30	dBc	
		Non-harmonic Spurious				-60	dBc	
	VSWR	Load VSWR, all phases				3.5:1		
	Φ_n	SSB (single sideband) Phase Noise, offset from carrier @ 1747.623000MHz	10kHz Offset		-95		dBc/Hz	
		100kHz Offset		-116		dBc/Hz		
		1MHz Offset		-134		dBc/Hz		
		10MHz Offset		-140		dBc/Hz		
		20MHz Offset		-143		dBc/Hz		

Table 6: AC Characteristics for M690SDM

Note 1: Also fully meets ±50 ppm minimum pull-range.

DEVICE PACKAGE - 13 x 20mm SMT (Surface Mount) Package

Mechanical Dimensions:

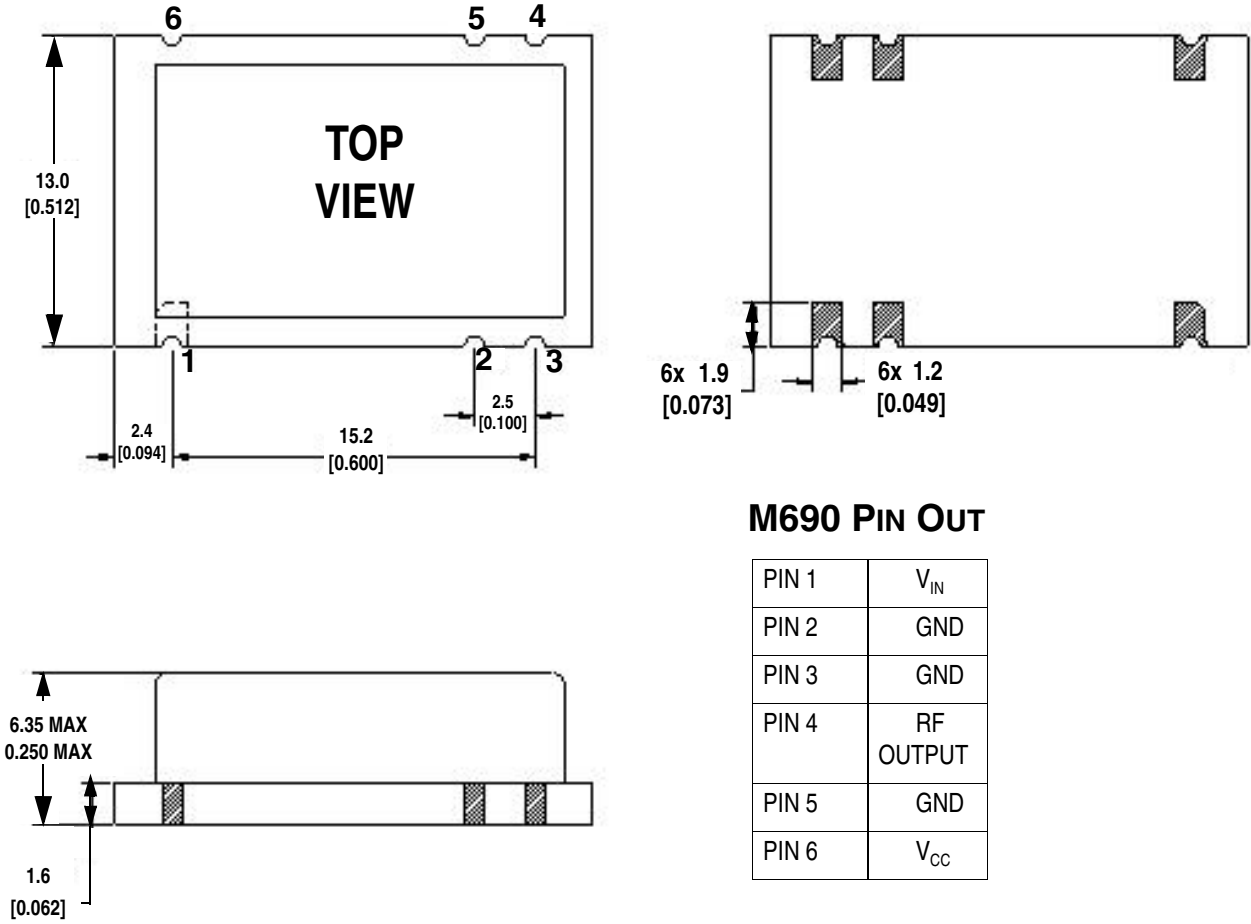

M690 PIN OUT

PIN 1	V_{IN}
PIN 2	GND
PIN 3	GND
PIN 4	RF OUTPUT
PIN 5	GND
PIN 6	V_{CC}

Pad Finish: Gold over Nickel
MSL 1

Figure 3: Device Package - 13 x 20mm SMT (Surface Mount Package)

ORDERING INFORMATION

Part Numbering Scheme

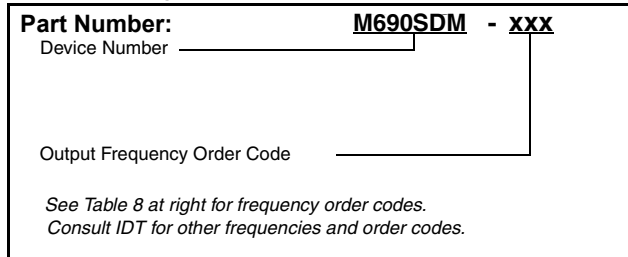

Figure 4: Part Numbering Scheme

Example Order Numbers

For Output Frequencies (MHz) Frequency	Order Part Number M690SDM-xxx
1747.623000	M690SDM-R01
1747.030837	M690SDM-R02

Table 7: Example Order Numbers

M690SDM Standard Output Frequencies & Order Codes

Output Frequency Code	Output Frequency MHz
R01	1747.623000
R02	1747.030837
R03	1748.366885
R04	1748.793733

Table 8: M690SDM Standard Output Frequencies & Order

Consult IDT for the availability of other frequencies

IMPORTANT NOTICE AND DISCLAIMER

RENESAS ELECTRONICS CORPORATION AND ITS SUBSIDIARIES (“RENESAS”) PROVIDES TECHNICAL SPECIFICATIONS AND RELIABILITY DATA (INCLUDING DATASHEETS), DESIGN RESOURCES (INCLUDING REFERENCE DESIGNS), APPLICATION OR OTHER DESIGN ADVICE, WEB TOOLS, SAFETY INFORMATION, AND OTHER RESOURCES “AS IS” AND WITH ALL FAULTS, AND DISCLAIMS ALL WARRANTIES, EXPRESS OR IMPLIED, INCLUDING, WITHOUT LIMITATION, ANY IMPLIED WARRANTIES OF MERCHANTABILITY, FITNESS FOR A PARTICULAR PURPOSE, OR NON-INFRINGEMENT OF THIRD-PARTY INTELLECTUAL PROPERTY RIGHTS.

These resources are intended for developers who are designing with Renesas products. You are solely responsible for (1) selecting the appropriate products for your application, (2) designing, validating, and testing your application, and (3) ensuring your application meets applicable standards, and any other safety, security, or other requirements. These resources are subject to change without notice. Renesas grants you permission to use these resources only to develop an application that uses Renesas products. Other reproduction or use of these resources is strictly prohibited. No license is granted to any other Renesas intellectual property or to any third-party intellectual property. Renesas disclaims responsibility for, and you will fully indemnify Renesas and its representatives against, any claims, damages, costs, losses, or liabilities arising from your use of these resources. Renesas' products are provided only subject to Renesas' Terms and Conditions of Sale or other applicable terms agreed to in writing. No use of any Renesas resources expands or otherwise alters any applicable warranties or warranty disclaimers for these products.

(Disclaimer Rev.1.01)

Corporate Headquarters

TOYOSU FORESIA, 3-2-24 Toyosu,
Koto-ku, Tokyo 135-0061, Japan
www.renesas.com

Trademarks

Renesas and the Renesas logo are trademarks of Renesas Electronics Corporation. All trademarks and registered trademarks are the property of their respective owners.

Contact Information

For further information on a product, technology, the most up-to-date version of a document, or your nearest sales office, please visit www.renesas.com/contact-us/.