

## Description

The MK1491-06 is a low-cost, low-jitter, high-performance clock synthesizer for AMD's Geode-based computer and portable appliance applications. Using patented analog Phased-Locked Loop (PLL) techniques, the device accepts a 14.318 MHz crystal input to produce multiple output clocks. It provides selectable PCI local bus and AC97 audio clocks, 24 MHz and 48 MHz clocks for Super I/O and USB, as well as multiple Reference outputs.

The device has multiple power-down modes to reduce power consumption.

## Features

- Packaged in 28-pin SOIC or in 28-pin SSOP
- Pb (lead) free, RoHS compliant
- Provides all critical timing for the AMD Geode companion chip
- Four PCI clocks
- Selectable PCIF on up to 2 outputs
- Early PCI clock selectability
- Up to 4 Reference clocks
- 48 MHz USB and 24MHz SIO support
- AC97 audio clock
- Multiple power down modes
- Low EMI Enable pin reduces EMI radiation on PCI clocks (patented)
- Operating voltage of 3.3 V  $\pm$ 5%
- Available in commercial (0 to +70°C) and industrial (-40°C to +85°C) temperature ranges

## Block Diagram

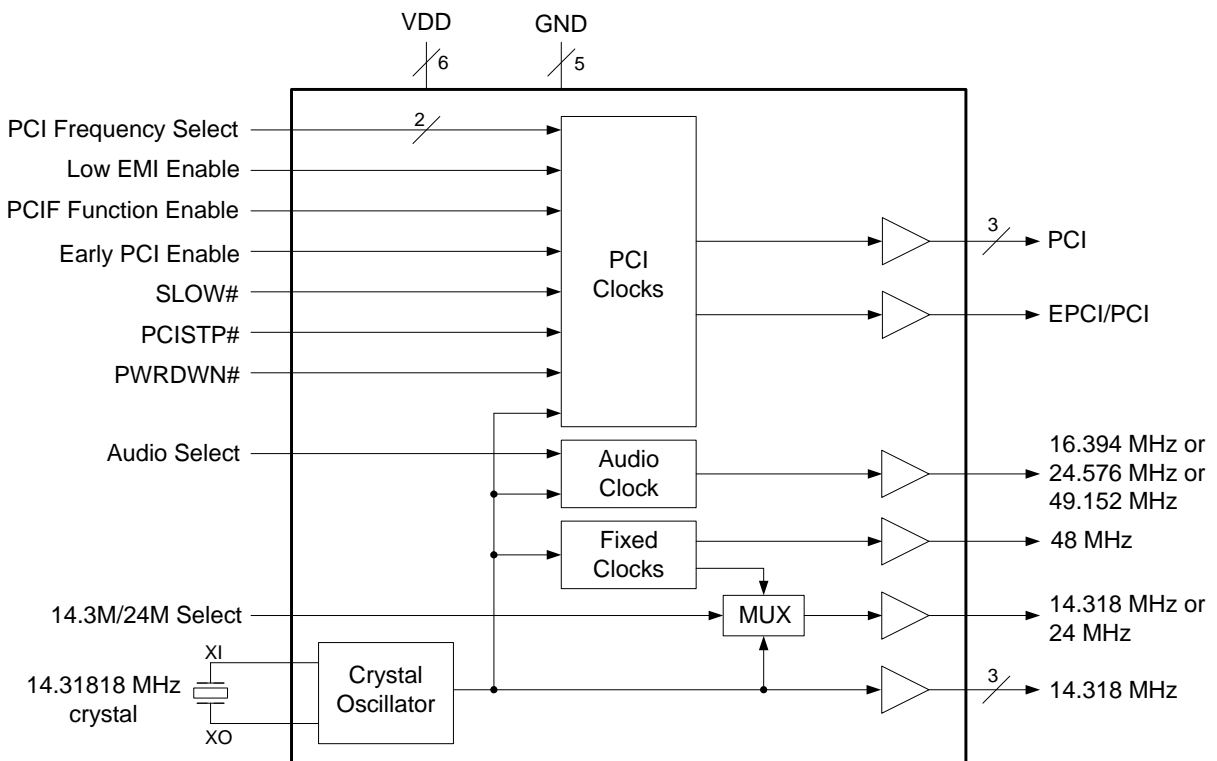

## Pin Assignment

VDD	<input type="checkbox"/>	1	28	<input type="checkbox"/>	AC97 AUDIO (PEN)
XI	<input type="checkbox"/>	2	27	<input type="checkbox"/>	PCI
XO	<input type="checkbox"/>	3	26	<input type="checkbox"/>	VDD
GND	<input type="checkbox"/>	4	25	<input type="checkbox"/>	PCI
14.3M (TS)	<input type="checkbox"/>	5	24	<input type="checkbox"/>	PCI
14.3M	<input type="checkbox"/>	6	23	<input type="checkbox"/>	GND
GND	<input type="checkbox"/>	7	22	<input type="checkbox"/>	PCI (EPCI#)
14.3M (SEL AUDIO)	<input type="checkbox"/>	8	21	<input type="checkbox"/>	48M (LE#)
VDD	<input type="checkbox"/>	9	20	<input type="checkbox"/>	VDD
SLOW#	<input type="checkbox"/>	10	19	<input type="checkbox"/>	24M/14.3M
GND	<input type="checkbox"/>	11	18	<input type="checkbox"/>	VDD
FS	<input type="checkbox"/>	12	17	<input type="checkbox"/>	GND
SEL24	<input type="checkbox"/>	13	16	<input type="checkbox"/>	PCISTP#
VDD	<input type="checkbox"/>	14	15	<input type="checkbox"/>	PWRDWN#

## Early PCI Control Table

EPCI#	PCI (Pin 22)
0	1 ns early
1	Normal

## EMI Control

LE#	PCI Low EMI
0	ON
1	OFF

Spread direction is DOWN.

## Pin Descriptions

Pin Number	Pin Name	Pin Type	Pin Description
1, 9, 14	VDD	P	Connect to +3.3 V. Must be same voltage on all pins.
2	XI	I	Crystal connection. Connect to a 14.31818 MHz crystal or input clock.
3	XO	O	Crystal connection. Connect to a 14.31818 MHz crystal, or leave unconnected for clock.
4, 7, 11, 17, 23	GND	P	Connect to Ground.
5	14.3M (TS)	TI/O	14.318 MHz output. Input control for all clocks per table above.
6	14.3M	O	14.318 MHz buffered reference clock output.

## PCI Frequency Select Table

TS	FS	PCI
0	0	Tristate all clocks
0	1	Reserved
M	0	30 MHz
M	1	33.3 MHz
1	0	25 MHz
1	1	37.5 MHz

## 24M/14.3M Frequency Select Table

SEL24	24M/14.3M
0	14.31818 MHz
1	24.0 MHz

## PCIF Enable Control

PEN	Pin 25	Pin 24
0	PCI	PCI
M	PCI	PCIF
1	PCIF	PCIF

PCIF continues to run in PCI STOP mode. See table on page 4.

## AC97 Audio Frequency Select

SEL AUDIO	AC97 AUDIO
0	16.9344 MHz
M	24.576 MHz
1	49.152 MHz

Pin Number	Pin Name	Pin Type	Pin Description
8	14.3M (SEL AUDIO)	TI/O	14.318 MHz output and audio frequency select input per table above.
10	SLOW#	I	PCI normal or slow mode select input per table on page 4.
12	FS	I	Frequency Select for PCI clocks per table above.
13	SEL24	I	Fixed frequency select input per table above. Selects frequency on pin 19.
15	PWRDWN#	I	Power down control; defined in table on page 4.
16	PCISTP#	I	PCI Stop power down control; defined in table on page 4.
18, 20, 26	VDD	P	Connect to +3.3 V. Must be same voltage on all pins.
19	24M/14.3M	O	Fixed frequency clock output per table above.
21	48 (LE#)	I/O	Fixed frequency clock output and low EMI (spread spectrum) enable input per table above.
22	PCI (EPCI#)	I/O	PCI Output clock that can be early. Input control for Early PCI per table above.
24	PCI	O	PCI Output clock. PCI/PCIF control set by PEN per table above.
25	PCI	O	PCI Output clock. PCI/PCIF control set by PEN per table above.
27	PCI	O	PCI Output clock.
28	AC97 AUDIO (PEN)	TI/O	Audio clock output and PCIF Function Enable per table above.

**KEY:**

I = Input

TI = Tri-level

O = Output

P = Power supply connection

(T)I/O = Input on power up, becomes an Output after 10 ms

Weak internal pull-up resistors are present on SEL24, EPCI#, FS, LE#, PCISTP#, and SLOW#. These pins should be tied to VDD or GND, and not be left floating. Internal resistors on PEN, SEL AUDIO, and TS pull to mid-level (M).

## Power Down Control Table

PCISTP#	PWRDWN#	SLOW#	MODE	PCI	PCIF	24/14.3	14.3	Description
X	0	X	Power down	LOW	LOW	LOW	LOW	All outputs low. PLL's and oscillators off.
0	1	X	PCI STOP	LOW	ON	ON	ON	PCI clocks synchronously enter and leave low state.
1	1	X	ON	ON	ON	ON	ON	All clocks on.

Key: 1 = connected to VDD, 0 = connected to ground, X = any valid logic level, combination inputs/outputs should be connected to VDD or ground through a 10 k $\Omega$  resistor as shown below.

## Power-on Default Conditions

Pin #	Function	Default	Condition
5	TS	M	All outputs enabled.
8	SEL AUDIO	M	Audio clock (pin 28) set to 24.576 MHz
10	SLOW#	1	PCI clocks set to 33.3 MHz. Refer to Power Down Control Table above.
12	FS	1	PCI frequency = 33.3 MHz.
13	SEL 24	1	24M/14.3M (pin 19) set to 24 MHz.
15	PWRDWN#	1	All clocks running.
16	PCISTP#	1	PCI clocks running.
21	LE#	1	Low EMI function OFF
22	EPCI#	1	Pin 22 set to normal PCI signal (not early).
28	PEN	M	PCI (pin 25) set to PCI clock (33.33 MHz). PCI (pin 24) set to PCIF clock (33.33 MHz).

## External Components

The MK1491-06 requires some inexpensive external components for proper operation. Decoupling capacitors of 0.1 $\mu$ F should be connected on each VDD pin to ground, as close to the MK1491-06 as possible. A series termination resistor of 33 $\Omega$  may be used for each clock output. See the discussion below for other external resistors required for proper I/O operation. The 14.3 MHz oscillator has internal caps that provide the proper load for a parallel resonant crystal with  $C_L=18$  pF. For tuning with other values of  $C_L$ , the formula  $2*(C_L-18)$  gives the value of each capacitor that should be connected between X1 and ground and X2 and ground.

## I/O Structure

The MK1491-06 provides more functionality in a 28-pin package by using a unique I/O technique. The device checks the status of all I/O pins during power-up and at exit from the Power Down state. This status (pulled high, low, or mid-level) then determines the frequency selections and power down modes (see the tables on pages 2 and 4). Within 10ms after power up, the inputs change to outputs and the clocks start up. In the diagrams to the right, the 33 $\Omega$  resistors are the normal output termination resistors. The 10k $\Omega$  resistor pulls low to generate a logic zero. Weak internal pull-up resistors are present on SEL24, EPCI#, FS, LE#, PCISTP#, and SLOW#. These pins should be connected directly to VDD or GND if not under active control. Internal resistors on PEN, SEL AUDIO, and TS pull to a mid-level (M).

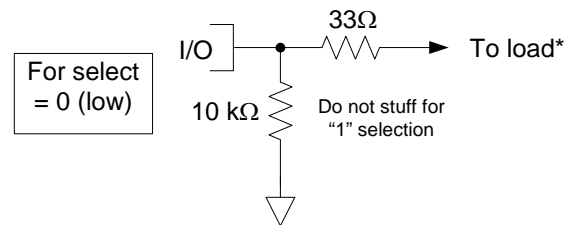

\*Note: Do not use a TTL load. This will overcome the 10 k $\Omega$  pull-down and force the input to a logic 1.

## Absolute Maximum Ratings

Stresses above the ratings listed below can cause permanent damage to the MK1491-06. These ratings, which are standard values for IDT commercially rated parts, are stress ratings only. Functional operation of the device at these or any other conditions above those indicated in the operational sections of the specifications is not implied. Exposure to absolute maximum rating conditions for extended periods can affect product reliability. Electrical parameters are guaranteed only over the recommended operating temperature range.

Item	Rating
Supply Voltage, VDD	7 V
All Inputs and Outputs	-0.5 V to VDD+0.5 V
Storage Temperature	-65 to +150°C
Junction Temperature	125°C
Soldering Temperature	260°C

## Recommended Operation Conditions

Parameter	Min.	Typ.	Max.	Units
Ambient Operating Temperature (commercial)	0		+70	°C
Ambient Operating Temperature (industrial)	-40		+85	°C
Power Supply Voltage (measured in respect to GND)	+3.15	+3.3	+3.45	V

## DC Electrical Characteristics

Unless stated otherwise, VDD = 3.3 V ±5%, Ambient Temperature 0 to +70°C or -40 to +85°C

Parameter	Symbol	Conditions	Min.	Typ.	Max.	Units
Operating Voltage	VDD		3.15	3.3	3.45	V
Input High Voltage	V <sub>IH</sub>		2			V
Input Mid-level Voltage	V <sub>IM</sub>		1.2	1.4	1.6	V
Input Low Voltage	V <sub>IL</sub>				0.8	V
Output High Voltage	V <sub>OH</sub>	I <sub>OH</sub> = -8 mA	2.4			V
Output Low Voltage	V <sub>OL</sub>	I <sub>OL</sub> = 8 mA			0.4	V
Output High Voltage	V <sub>OH</sub>	I <sub>OH</sub> = -8 mA	VDD-0.4			V
Operating Supply Current	IDD	33 MHz, no load		30		mA
Power Down Mode Supply Current				15		μA
Short Circuit Current, Single Output Driver		VDD = 3.3 V		±60		mA
Input Capacitance	C <sub>IN</sub>			7		pF

## AC Electrical Characteristics

Unless stated otherwise, VDD = 3.3 V ±5%, Ambient Temperature 0 to +70°C or -40 to +85° C

Parameter	Symbol	Conditions	Min.	Typ.	Max.	Units
Input Frequency	$F_{IN}$			14.31818		MHz
Output Clock Rise Time	$t_{OR}$	20% to 80%			1.5	ns
Output Clock Fall Time	$t_{OF}$	80% to 20%			1.5	ns
Output Clock Duty Cycle, all MHz Clocks	$t_{OD}$	At 1.5 V	45	49 to 51	55	%
PCI Output to Output Skew		Rising edges at 1.5 V			500	ps
Skew of EPCI with respect to PCI				1		ns
Cycle-to-Cycle Jitter, PCI clocks				250		ps
EMI Reduction, peaks of 5th - 19th odd harmonics		33.3 MHz PCI Clock		6	11	dB
Power-up Time, PWRDWN# High to all Clocks Stable				8	20	ms
Power-on Time, applied VDD to all Clocks Stable				12	25	ms

## Thermal Characteristics

Parameter	Symbol	Conditions	Min.	Typ.	Max.	Units
Thermal Resistance Junction to Ambient	$\theta_{JA}$	Still air		100		°C/W
	$\theta_{JA}$	1 m/s air flow		80		°C/W
	$\theta_{JA}$	3 m/s air flow		67		°C/W
Thermal Resistance Junction to Case	$\theta_{JC}$			60		°C/W

## Marking Diagrams



MK1491-06RLF



MK1491-06RILF

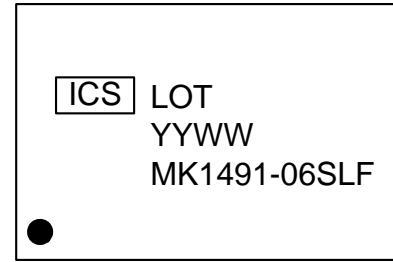

MK1491-06SLF

### Notes:

1. LOT is the lot code.
2. YYWW is the last two digits of the year, and the week number that the part was assembled.
3. Bottom marking: country of origin.

### Package Outline and Package Dimensions (28-pin SOIC, 150 mil Body)

Package dimensions are kept current with JEDEC Publication No. 95, MO-153

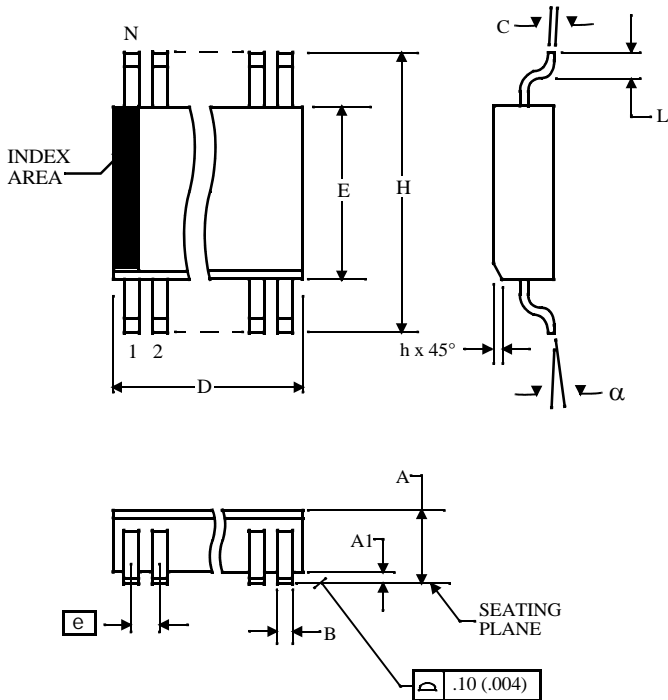

Symbol	Millimeters		Inches	
	Min	Max	Min	Max
A		2.65		0.104
A1	0.10		.0040	
B	0.33	0.51	.013	.020
C	0.18	0.32	.007	.013
D	17.70	18.40	.697	.724
E	7.40	7.60	.291	.299
e	1.27 Basic		0.050 Basic	
H	10.00	10.65	.394	.419
h	0.25	0.75	.010	.029
L	0.40	1.27	.016	.050
alpha	0°	8°	0°	8°

## Package Outline and Package Dimensions (28-pin SSOP, 150 mil Body, 0.025 mm Pitch)

Package dimensions are kept current with JEDEC Publication No. 95, MO-153

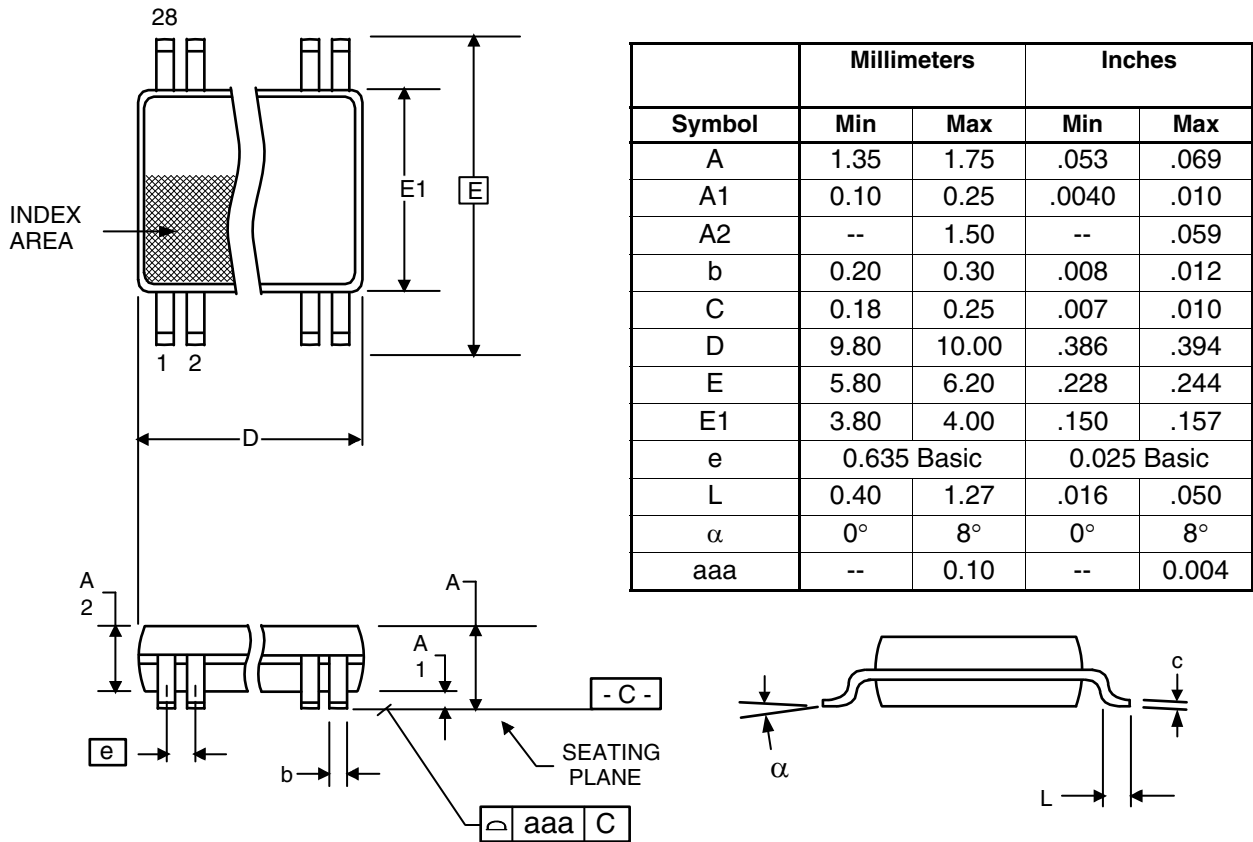

## Ordering Information

Part / Order Number	Marking	Shipping Packaging	Package	Temperature
MK1491-06RLF	see page 8	Tubes	28-pin SSOP	0 to +70°C
MK1491-06RLFTR		Tape and Reel	28-pin SSOP	0 to +70°C
MK1491-06RILF		Tubes	28-pin SSOP	-40 to +85°C
MK1491-06RILFTR		Tape and Reel	28-pin SSOP	-40 to +85°C
MK1491-06SLF		Tubes	28-pin SOIC	0 to +70°C
MK1491-06SLFTR		Tape and Reel	28-pin SOIC	0 to +70°C

“LF” denotes Pb (lead) free package, RoHS compliant.

While the information presented herein has been checked for both accuracy and reliability, Integrated Device Technology (IDT) assumes no responsibility for either its use or for the infringement of any patents or other rights of third parties, which would result from its use. No other circuits, patents, or licenses are implied. This product is intended for use in normal commercial applications. Any other applications such as those requiring extended temperature range, high reliability, or other extraordinary environmental requirements are not recommended without additional processing by IDT. IDT reserves the right to change any circuitry or specifications without notice. IDT does not authorize or warrant any IDT product for use in life support devices or critical medical instruments.

## Revision History

Rev.	Date	Originator	Description of Change
M	06/09/14	RDW	Added I-temp throughout datasheet.



## IMPORTANT NOTICE AND DISCLAIMER

RENESAS ELECTRONICS CORPORATION AND ITS SUBSIDIARIES (“RENESAS”) PROVIDES TECHNICAL SPECIFICATIONS AND RELIABILITY DATA (INCLUDING DATASHEETS), DESIGN RESOURCES (INCLUDING REFERENCE DESIGNS), APPLICATION OR OTHER DESIGN ADVICE, WEB TOOLS, SAFETY INFORMATION, AND OTHER RESOURCES “AS IS” AND WITH ALL FAULTS, AND DISCLAIMS ALL WARRANTIES, EXPRESS OR IMPLIED, INCLUDING, WITHOUT LIMITATION, ANY IMPLIED WARRANTIES OF MERCHANTABILITY, FITNESS FOR A PARTICULAR PURPOSE, OR NON-INFRINGEMENT OF THIRD-PARTY INTELLECTUAL PROPERTY RIGHTS.

These resources are intended for developers who are designing with Renesas products. You are solely responsible for (1) selecting the appropriate products for your application, (2) designing, validating, and testing your application, and (3) ensuring your application meets applicable standards, and any other safety, security, or other requirements. These resources are subject to change without notice. Renesas grants you permission to use these resources only to develop an application that uses Renesas products. Other reproduction or use of these resources is strictly prohibited. No license is granted to any other Renesas intellectual property or to any third-party intellectual property. Renesas disclaims responsibility for, and you will fully indemnify Renesas and its representatives against, any claims, damages, costs, losses, or liabilities arising from your use of these resources. Renesas' products are provided only subject to Renesas' Terms and Conditions of Sale or other applicable terms agreed to in writing. No use of any Renesas resources expands or otherwise alters any applicable warranties or warranty disclaimers for these products.

(Disclaimer Rev.1.01)

### Corporate Headquarters

TOYOSU FORESIA, 3-2-24 Toyosu,  
Koto-ku, Tokyo 135-0061, Japan  
[www.renesas.com](http://www.renesas.com)

### Trademarks

Renesas and the Renesas logo are trademarks of Renesas Electronics Corporation. All trademarks and registered trademarks are the property of their respective owners.

### Contact Information

For further information on a product, technology, the most up-to-date version of a document, or your nearest sales office, please visit [www.renesas.com/contact-us/](http://www.renesas.com/contact-us/).