

R1Q4A7236ABB

R1Q4A7218ABB

72-Mbit DDRII SRAM

R10DS0166EJ0203

2-word Burst

Rev. 2.03

Feb 01, 2019

Description

The R1Q4A7236 is a 2,097,152-word by 36-bit and the R1Q4A7218 is a 4,194,304-word by 18-bit synchronous double data rate static RAM fabricated with advanced CMOS technology using full CMOS six-transistor memory cell. It integrates unique synchronous peripheral circuitry and a burst counter. All input registers are controlled by an input clock pair (K and /K) and are latched on the positive edge of K and /K. These products are suitable for applications which require synchronous operation, high speed, low voltage, high density and wide bit configuration. These products are packaged in 165-pin plastic FBGA package.

Features

Power Supply

- 1.8 V for core (V_{DD}), 1.4 V to V_{DD} for I/O (V_{DDQ})

Clock

- Fast clock cycle time for high bandwidth
- Two input clocks (K and /K) for precise DDR timing at clock rising edges only
- Two input clocks for output data (C and /C) to minimize clock skew and flight time mismatches
- Two output echo clocks (CQ and /CQ) simplify data capture in high-speed systems
- Clock-stop capability with μs restart

I/O

- Common data input/output bus
- Pipelined double data rate operation
- HSTL I/O
- User programmable output impedance
- DLL/PLL circuitry for wide output data valid window and future frequency scaling

Function

- Two-tick burst for low DDR transaction size
- Internally self-timed write control
- Simple control logic for easy depth expansion
- JTAG 1149.1 compatible test access port

Package

- 165 FBGA package (13 x 15 x 1.4 mm)
- RoHS Compliance Level = 6/6

Part Number Definition

Column No.	0	1	2	3	4	5	6	7	8	9	10	11	-	12	13	14	15	16
Example	R	1	Q	4	A	7	2	1	8	A	B	B	-	3	3	I	B	1
The above part number is just example for 72M DDRII B2 x18 300MHz, 13x15mm PKG, Pb-free part.																		

No.	-	Comments	No.	-	Comments
0-1	R1	Renesas Memory Prefix	9	A	2nd Generation
2-3	Q2	QDR II B2 ^[*1] (L15) ^[*2]	10-11	BB	PKG = BGA 13x15 mm
	Q3	QDR II B4 (L15)	12-13	40	Frequency = 250MHz
	Q4	DDR II B2 (L15)		33	Frequency = 300MHz
	QA	QDR II+ B4 L25		25	Frequency = 400MHz
	QB	DDR II+ B2 L25	14	20	Frequency = 500MHz
	QD	QDR II+ B4 L25 w/ ODT ^[*3]		19	Frequency = 533MHz
	QE	DDR II+ B2 L25 w/ ODT	15	I	Industrial temp. T _a range = -40°C to 85°C
	QG	QDR II+ B2 L20		16	B
QH	DDR II+ B2 L20				
4	A	V _{DD} = 1.8 V	16	0 to 9, A to Z or None	Renesas internal use
5-6	72	Density = 72Mb			
7-8	09	Data width = 9bit			
	18	Data width = 18bit			
	36	Data width = 36bit			

- Notes[*]**
1. B=Burst length (B2: Burst length=2, B4: Burst length=4)
 2. L=Read Latency (L15: Read Latency = 1.5 cycle, L20: 2.0 cycle, L25: 2.5 cycle)
 3. ODT=On Die Termination

72M QDR/DDR SRAM (R1Q*A72 Series) Lineup

Renesas supports the parts listed below.

No	Product Type	Burst Length	Latency (Cycle)	ODT	Organi- zation	Frequency (max) (MHz)	533	500	400	300	250						
						Cycle Time (min) (ns)	1.875	2.00	2.50	3.30	4.00						
1	QDRII	B2	1.5	No	x 9	R1Q2A7209ABB-yy											
2					x18	R1Q2A7218ABB-yy											
3					x36	R1Q2A7236ABB-yy											
4		B4			x18	R1Q3A7218ABB-yy											
5					x36	R1Q3A7236ABB-yy											
6	DDRII	B2			x18	R1Q4A7218ABB-yy											
7					x36	R1Q4A7236ABB-yy											
8	QDRII+	B4	2.5	No	x18	R1QAA7218ABB-yy	-19	-20									
9					x36	R1QAA7236ABB-yy											
10	DDRII+	B2			x18	R1QBA7218ABB-yy											
11					x36	R1QBA7236ABB-yy											
12	QDRII+	B4			Yes	x18						R1QDA7218ABB-yy	-19	-20			
13						x36						R1QDA7236ABB-yy					
14	DDRII+	B2		x18		R1QEA7218ABB-yy											
15				x36		R1QEA7236ABB-yy											
16	QDRII+	B4		2.0	No	x18	R1QGA7218ABB-yy			-25							
17						x36	R1QGA7236ABB-yy										
18	DDRII+	B2				x18	R1QHA7218ABB-yy										
			x36			R1QHA7236ABB-yy											

Notes 1. "yy" represents the speed bin. "R1QDA7236ABB-20" can operate at 500 MHz(max) of frequency, for example.

2. The part which is not listed above is not supported, as of the day when this datasheet was issued, in spite of the existence of the part number or datasheet.

Pin Arrangement

R1Q4A7236 series (Top View)

	1	2	3	4	5	6	7	8	9	10	11
A	/CQ	NC	SA	R-/W	/BW2	/K	/BW1	/LD	SA	SA	CQ
B	NC	DQ27	DQ18	SA	/BW3	K	/BW0	SA	NC	NC	DQ8
C	NC	NC	DQ28	V _{SS}	SA	SA0	SA	V _{SS}	NC	DQ17	DQ7
D	NC	DQ29	DQ19	V _{SS}	V _{SS}	V _{SS}	V _{SS}	V _{SS}	NC	NC	DQ16
E	NC	NC	DQ20	V _{DDQ}	V _{SS}	V _{SS}	V _{SS}	V _{DDQ}	NC	DQ15	DQ6
F	NC	DQ30	DQ21	V _{DDQ}	V _{DD}	V _{SS}	V _{DD}	V _{DDQ}	NC	NC	DQ5
G	NC	DQ31	DQ22	V _{DDQ}	V _{DD}	V _{SS}	V _{DD}	V _{DDQ}	NC	NC	DQ14
H	/DOFF	V _{REF}	V _{DDQ}	V _{DDQ}	V _{DD}	V _{SS}	V _{DD}	V _{DDQ}	V _{DDQ}	V _{REF}	ZQ
J	NC	NC	DQ32	V _{DDQ}	V _{DD}	V _{SS}	V _{DD}	V _{DDQ}	NC	DQ13	DQ4
K	NC	NC	DQ23	V _{DDQ}	V _{DD}	V _{SS}	V _{DD}	V _{DDQ}	NC	DQ12	DQ3
L	NC	DQ33	DQ24	V _{DDQ}	V _{SS}	V _{SS}	V _{SS}	V _{DDQ}	NC	NC	DQ2
M	NC	NC	DQ34	V _{SS}	V _{SS}	V _{SS}	V _{SS}	V _{SS}	NC	DQ11	DQ1
N	NC	DQ35	DQ25	V _{SS}	SA	SA	SA	V _{SS}	NC	NC	DQ10
P	NC	NC	DQ26	SA	SA	C	SA	SA	NC	DQ9	DQ0
R	TDO	TCK	SA	SA	SA	/C	SA	SA	SA	TMS	TDI

- Notes**
1. Address expansion order for future higher density SRAMs: 10A → 2A → 7A → 5B.
 2. NC pins can be left floating or connected to 0V ~ V_{DDQ}.

R1Q4A7218 series
(Top View)

	1	2	3	4	5	6	7	8	9	10	11
A	/CQ	SA	SA	R-/W	/BW1	/K	NC	/LD	SA	SA	CQ
B	NC	DQ9	NC	SA	NC	K	/BW0	SA	NC	NC	DQ8
C	NC	NC	NC	V _{SS}	SA	SA0	SA	V _{SS}	NC	DQ7	NC
D	NC	NC	DQ10	V _{SS}	V _{SS}	V _{SS}	V _{SS}	V _{SS}	NC	NC	NC
E	NC	NC	DQ11	V _{DDQ}	V _{SS}	V _{SS}	V _{SS}	V _{DDQ}	NC	NC	DQ6
F	NC	DQ12	NC	V _{DDQ}	V _{DD}	V _{SS}	V _{DD}	V _{DDQ}	NC	NC	DQ5
G	NC	NC	DQ13	V _{DDQ}	V _{DD}	V _{SS}	V _{DD}	V _{DDQ}	NC	NC	NC
H	/DOFF	V _{REF}	V _{DDQ}	V _{DDQ}	V _{DD}	V _{SS}	V _{DD}	V _{DDQ}	V _{DDQ}	V _{REF}	ZQ
J	NC	NC	NC	V _{DDQ}	V _{DD}	V _{SS}	V _{DD}	V _{DDQ}	NC	DQ4	NC
K	NC	NC	DQ14	V _{DDQ}	V _{DD}	V _{SS}	V _{DD}	V _{DDQ}	NC	NC	DQ3
L	NC	DQ15	NC	V _{DDQ}	V _{SS}	V _{SS}	V _{SS}	V _{DDQ}	NC	NC	DQ2
M	NC	NC	NC	V _{SS}	V _{SS}	V _{SS}	V _{SS}	V _{SS}	NC	DQ1	NC
N	NC	NC	DQ16	V _{SS}	SA	SA	SA	V _{SS}	NC	NC	NC
P	NC	NC	DQ17	SA	SA	C	SA	SA	NC	NC	DQ0
R	TDO	TCK	SA	SA	SA	/C	SA	SA	SA	TMS	TDI

Notes 1. Address expansion order for future higher density SRAMs: 10A → 2A → 7A → 5B.

2. NC pins can be left floating or connected to 0V ~ V_{DDQ}.

Pin Description

Name	I/O type	Descriptions	Notes
SA _x	Input	Synchronous address inputs: These inputs are registered and must meet the setup and hold times around the rising edge of K. All transactions operate on a burst-of-four words (two clock periods of bus activity). SA0 and SA1 are used as the lowest two address bits for burst READ and burst WRITE operations permitting a random burst start address on $\times 18$ and $\times 36$ of DDR II (not II+) devices. These inputs are ignored when device is deselected or once burst operation is in progress.	
/LD	Input	Synchronous load: This input is brought low when a bus cycle sequence is to be defined. This definition includes address and READ / WRITE direction. All transactions operate on a burst-of-four data (two clock periods of bus activity).	
R-/W	Input	Synchronous read / write Input: When /LD is low, this input designates the access type (READ when R-/W is high, WRITE when R-/W is low) for the loaded address. R-/W must meet the setup and hold times around the rising edge of K.	
/BW _x	Input	Synchronous byte writes: When low, these inputs cause their respective byte to be registered and written during WRITE cycles. These signals are sampled on the same edge as the corresponding data and must meet setup and hold times around the rising edges of K and /K for each of the two rising edges comprising the WRITE cycle. See Byte Write Truth Table for signal to data relationship.	
K, /K	Input	Input clock: This input clock pair registers address and control inputs on the rising edge of K, and registers data on the rising edge of K and the rising edge of /K. /K is ideally 180 degrees out of phase with K. All synchronous inputs must meet setup and hold times around the clock rising edges. These balls cannot remain V _{REF} level.	
C, /C	Input	Output clock: This clock pair provides a user-controlled means of tuning device output data. The rising edge of /C is used as the output timing reference for the first and third output data. The rising edge of C is used as the output timing reference for second and fourth output data. Ideally, /C is 180 degrees out of phase with C. C and /C may be tied high to force the use of K and /K as the output reference clocks instead of having to provide C and /C clocks. If tied high, C and /C must remain high and not to be toggled during device operation. These balls cannot remain V _{REF} level.	1
/DOFF	Input	DLL/PLL disable: When low, this input causes the DLL/PLL to be bypassed for stable, low frequency operation.	
TMS TDI	Input	IEEE1149.1 test inputs: 1.8 V I/O levels. These balls may be left not connected if the JTAG function is not used in the circuit.	
TCK	Input	IEEE1149.1 clock input: 1.8 V I/O levels. This ball must be tied to V _{SS} if the JTAG function is not used in the circuit.	
ZQ	Input	Output impedance matching input: This input is used to tune the device outputs to the system data bus impedance. DQ and CQ output impedance are set to $0.2 \times RQ$, where RQ is a resistor from this ball to ground. This ball can be connected directly to V _{DDQ} , which enables the minimum impedance mode. This ball cannot be connected directly to V _{SS} or left unconnected.	

Name	I/O type	Descriptions	Notes
DQ0 to DQn	Input /Output	Synchronous data I/Os: Input data must meet setup and hold times around the rising edges of K and /K. Output data is synchronized to the respective C and /C, or to the respective K and /K if C and /C are tied high. The ×18 device uses DQ0~DQ17. DQ18~DQ35 should be treated as NC pin. The ×36 device uses DQ0~DQ35.	
CQ, /CQ	Output	Synchronous echo clock outputs: The edges of these outputs are tightly matched to the synchronous data outputs and can be used as a data valid indication. These signals run freely and do not stop when DQ tri-states.	
TDO	Output	IEEE 1149.1 test output: 1.8 V I/O level.	
V _{DD}	Supply	Power supply: 1.8 V nominal. See DC Characteristics and Operating Conditions for range.	2
V _{DDQ}	Supply	Power supply: Isolated output buffer supply. Nominally 1.5 V. See DC Characteristics and Operating Conditions for range.	2
V _{SS}	Supply	Power supply: Ground.	2
V _{REF}	-	HSTL input reference voltage: Nominally V _{DDQ} /2, but may be adjusted to improve system noise margin. Provides a reference voltage for the HSTL input buffers.	
NC	-	No connect: These pins can be left floating or connected to 0V ~ V _{DDQ} .	

- Notes**
1. R1Q2, R1Q3, R1Q4 series have C and /C pins. R1QA, R1QB, R1QD, R1QE, R1QG, R1QH series do not have C, /C pins. In the series, K and /K are used as the output reference clocks instead of C and /C. Therefore, hereafter, C and /C represent K and /K in this document.
 2. All power supply and ground balls must be connected for proper operation of the device.

Block Diagram

R1Q4A7236 / R1Q4A7218 series

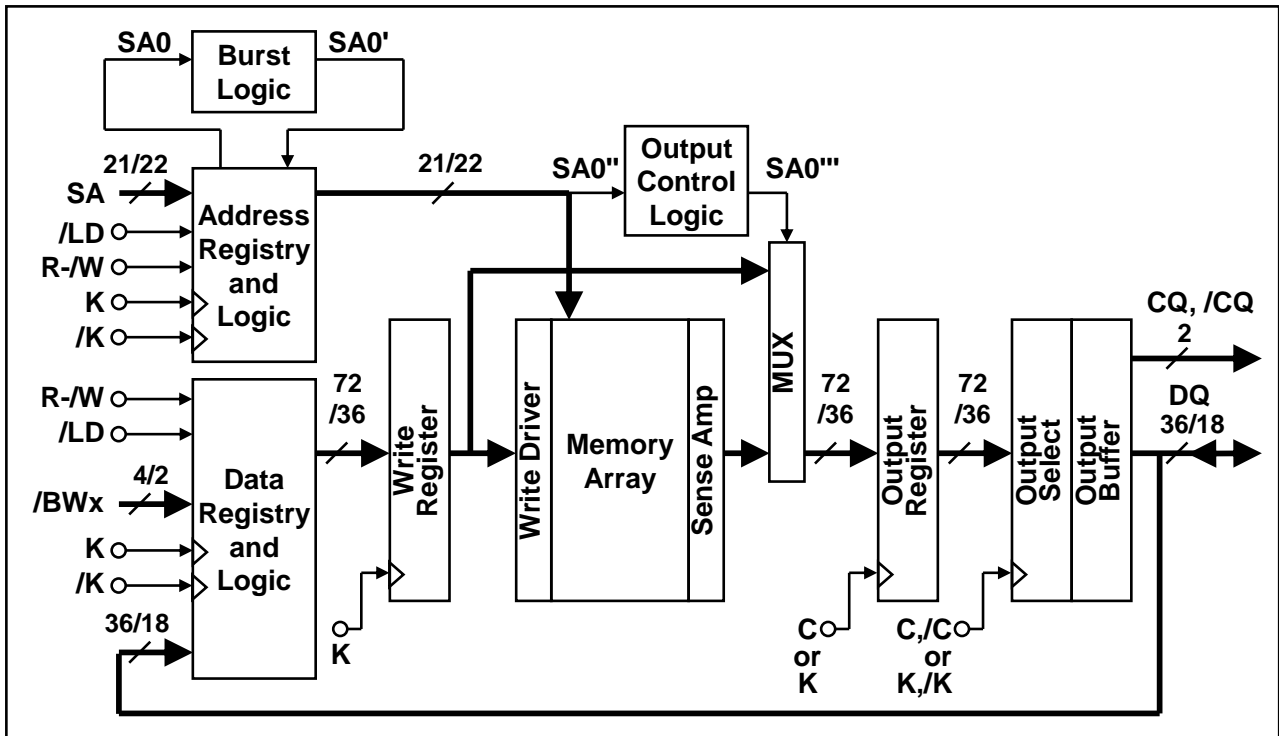

General Description

Power-up and Initialization Sequence

- V_{DD} must be stable before K, /K clocks are applied.
- Recommended voltage application sequence : $V_{SS} \rightarrow V_{DD} \rightarrow V_{DDQ} \& V_{REF} \rightarrow V_{IN}$ (0 V to V_{DD} , $V_{DDQ} < 200$ ms)
- Apply V_{REF} after V_{DDQ} or at the same time as V_{DDQ} .
- Then execute either one of the following three sequences.

1. Single Clock Mode (C and /C tied high)

- Drive /DOFF high (/DOFF can be tied high from the start).
- Then provide stable clocks (K, /K) for at least 1024 cycles (II series) or 20 us (II+ series).

These meet the QDR common specification of 20 us.

When the operating frequency is less than 180 MHz, 2048 cycles are required (II series).

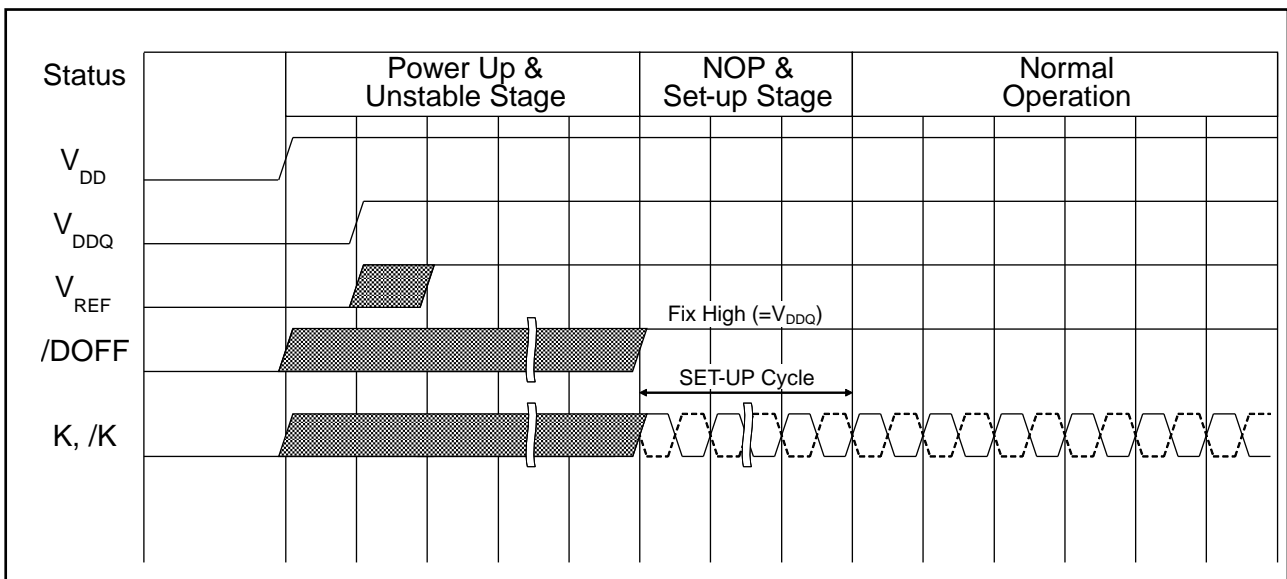

2. Double Clock Mode (C and /C control outputs) (II series only)

- Drive /DOFF high (/DOFF can be tied high from the start)
- Then provide stable clocks (K, /K, C, /C) for at least 1024 cycles.

This meets the QDR common specification of 20 us.

When the operating frequency is less than 180 MHz, 2048 cycles are required.

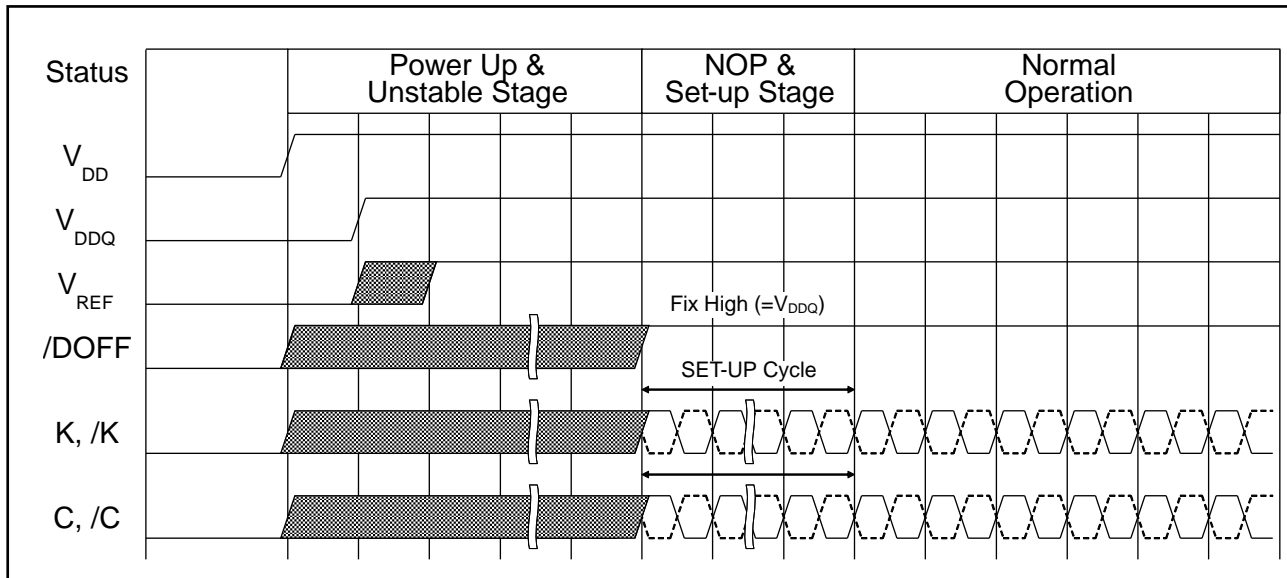

3. DLL/PLL Off Mode (/DOFF tied low)

- In the "NOP and setup stage", provide stable clocks (K, /K) for at least 1024 cycles (II series) or 20 us (II+ series). These meet the QDR common specification of 20 us.

DLL/PLL Constraints

1. DLL/PLL uses K clock as its synchronizing input. The input should have low phase jitter which is specified as $t_{KC \text{ var}}$.
2. The lower end of the frequency at which the DLL/PLL can operate is 120 MHz.
(Please refer to AC Characteristics table for detail.)
3. When the operating frequency is changed or /DOFF level is changed, setup cycles are required again.

Programmable Output Impedance

1. Output buffer impedance can be programmed by terminating the ZQ ball to V_{SS} through a precision resistor (R_Q). The value of R_Q is five times the output impedance desired. The allowable range of R_Q to guarantee impedance matching with a tolerance of 15% is 250 Ω typical. The total external capacitance of ZQ ball must be less than 7.5 pF.

K Truth Table

Operation	K	/LD	R-/W	DQ			
Write Cycle : Load address, input write data on consecutive K and /K rising edges	↑	L	L	Data in			
				Input data	D(A1)	D(A2)	
				Input clock	K(t+1) ↑	/K(t+1) ↑	
Read Cycle : Load address, output read data on consecutive C and /C rising edges	↑	L	H	Data out			
				Output data	Q(A1)	Q(A2)	
				Input clock for Q	RL ₈ = 1.5	/C(t+1) ↑	C(t+2) ↑
					RL = 2.0	C(t+2) ↑	/C(t+2) ↑
RL = 2.5	/C(t+2) ↑	C(t+3) ↑					
NOP (No operation)	↑	H	×	High-Z			
Standby (Clock stopped)	Stopped	×	×	Previous state			

Notes 1. H: high level, L: low level, ×: don't care, ↑: rising edge.

2. Data inputs are registered at K and /K rising edges. Data outputs are delivered at C and /C rising edges, except if C and /C are high, then data outputs are delivered at K and /K rising edges.
3. /LD and R-/W must meet setup/hold times around the rising edges (low to high) of K and are registered at the rising edge of K.
4. This device contains circuitry that will ensure the outputs will be in High-Z during power-up.
5. Refer to state diagram and timing diagrams for clarification.
6. When clocks are stopped, the following cases are recommended; the case of K = low, /K = high, C = low and /C = high, or the case of K = high, /K = low, C = high and /C = low. This condition is not essential, but permits most rapid restart by overcoming transmission line charging symmetrically.
7. A1 refers to the address input during a WRITE or READ cycle. A2 refers to the next internal burst address in accordance with the linear burst sequence.
8. RL = Read Latency (unit = cycle).

Burst Sequence

Linear Burst Sequence Table (R1Q4A7236ABB / R1Q4A7218ABB series)

	SA0	SA1	Notes
External Address	0	1	
1st internal burst address	1	0	

Byte Write Truth Table (x36)

Operation	K	/K	/BW0	/BW1	/BW2	/BW3
Write D0 to D35	↑	-	L	L	L	L
	-	↑	L	L	L	L
Write D0 to D8	↑	-	L	H	H	H
	-	↑	L	H	H	H
Write D9 to D17	↑	-	H	L	H	H
	-	↑	H	L	H	H
Write D18 to D26	↑	-	H	H	L	H
	-	↑	H	H	L	H
Write D27 to D35	↑	-	H	H	H	L
	-	↑	H	H	H	L
Write nothing	↑	-	H	H	H	H
	-	↑	H	H	H	H

Notes 1. H: high level, L: low level, ↑: rising edge.

2. Assumes a WRITE cycle was initiated. /BWx can be altered for any portion of the BURST WRITE operation provided that the setup and hold requirements are satisfied.

Byte Write Truth Table (x18)

Operation	K	/K	/BW0	/BW1
Write D0 to D17	↑	-	L	L
	-	↑	L	L
Write D0 to D8	↑	-	L	H
	-	↑	L	H
Write D9 to D17	↑	-	H	L
	-	↑	H	L
Write nothing	↑	-	H	H
	-	↑	H	H

Notes 1. H: high level, L: low level, ↑: rising edge.

2. Assumes a WRITE cycle was initiated. /BWx can be altered for any portion of the BURST WRITE operation provided that the setup and hold requirements are satisfied.

Bus Cycle State Diagram

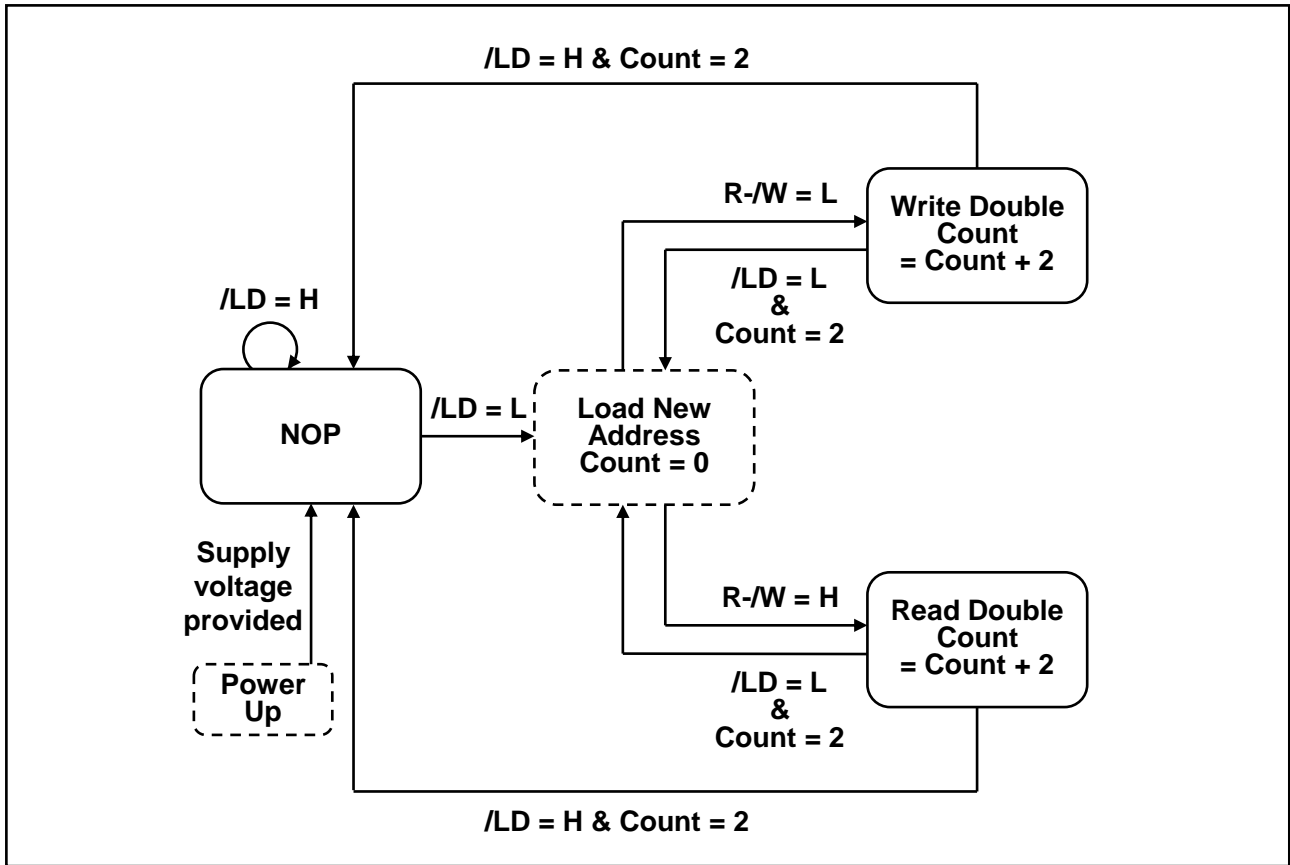

- Notes**
1. SA0 is internally advanced in accordance with the burst order table. Bus cycle is terminated at the end of this sequence (burst count = 2).
 2. State machine control timing sequence is controlled by K.

Absolute Maximum Ratings

Parameter	Symbol	Rating	Unit	Notes
Input voltage on any ball	V_{IN}	-0.5 to $V_{DD} + 0.5$ (2.5 V max.)	V	1, 4
Input/output voltage	V_{IO}	-0.5 to $V_{DDQ} + 0.5$ (2.5 V max.)	V	1, 4
Core supply voltage	V_{DD}	-0.5 to 2.5	V	1, 4
Output supply voltage	V_{DDQ}	-0.5 to V_{DD}	V	1, 4
Junction temperature	T_j	+125 (max)	°C	5
Storage temperature	T_{STG}	-55 to +125	°C	

Notes 1. All voltage is referenced to V_{SS} .

- Permanent device damage may occur if Absolute Maximum Ratings are exceeded. Functional operation should be restricted the Operation Conditions. Exposure to higher than recommended voltages for extended periods of time could affect device reliability.
- These CMOS memory circuits have been designed to meet the DC and AC specifications shown in the tables after thermal equilibrium has been established.
- The following supply voltage application sequence is recommended: V_{SS} , V_{DD} , V_{DDQ} , V_{REF} then V_{IN} . Remember, according to the Absolute Maximum Ratings table, V_{DDQ} is not to exceed 2.5 V, whatever the instantaneous value of V_{DDQ} .
- Some method of cooling or airflow should be considered in the system. (Especially for high frequency or ODT parts)

Recommended DC Operating Conditions

Parameter	Symbol	Min	Typ	Max	Unit	Notes
Power supply voltage – core	V_{DD}	1.7	1.8	1.9	V	1
Power supply voltage – I/O	V_{DDQ}	1.4	1.5	V_{DD}	V	1, 2
Input reference voltage – I/O	V_{REF}	0.68	0.75	0.95	V	3
Input high voltage	$V_{IH(DC)}$	$V_{REF} + 0.1$	-	$V_{DDQ} + 0.3$	V	1, 4, 5
Input low voltage	$V_{IL(DC)}$	-0.3	-	$V_{REF} - 0.1$	V	1, 4, 5

Notes 1. At power-up, V_{DD} and V_{DDQ} are assumed to be a linear ramp from 0V to $V_{DD}(\text{min.})$ or $V_{DDQ}(\text{min.})$ within 200ms. During this time $V_{DDQ} < V_{DD}$ and $V_{IH} < V_{DDQ}$. During normal operation, V_{DDQ} must not exceed V_{DD} .

- Please pay attention to T_j not to exceed the temperature shown in the absolute maximum ratings table due to current from V_{DDQ} .
- Peak to peak AC component superimposed on V_{REF} may not exceed 5% of V_{REF} .
- These are DC test criteria. The AC V_{IH} / V_{IL} levels are defined separately to measure timing parameters.
- Overshoot: $V_{IH(AC)} \leq V_{DDQ} + 0.5 \text{ V}$ for $t \leq t_{KHKH}/2$
Undershoot: $V_{IL(AC)} \geq -0.5 \text{ V}$ for $t \leq t_{KHKH}/2$

During normal operation, $V_{IH(DC)}$ must not exceed V_{DDQ} and $V_{IL(DC)}$ must not be lower than V_{SS} .

DC Characteristics $T_a = -40 \sim +85^\circ\text{C}$ $V_{DD} = 1.8V \pm 0.1V, V_{DDQ} = 1.5V, V_{REF} = 0.75V$ **Operating Supply Current (Write / Read)**Symbol = I_{DD} . Unit = mA.

No	Product Type	Burst Length	Latency (Cycle)	ODT	Organization	Frequency (max) (MHz)	533	500	400	300	250	200	
						Cycle Time (min) (ns)	1.875	2.00	2.50	3.30	4.00	5.00	
						Speed bin	-19	-20	-25	-33	-40		
1	QDR II	B2	1.5	No	x 9	R1Q2A7209ABB-yy					760	670	
2					x18	R1Q2A7218ABB-yy					890	780	
3					x36	R1Q2A7236ABB-yy					950	830	
4	B4	x18			R1Q3A7218ABB-yy			820	730				
5		x36			R1Q3A7236ABB-yy			850	750				
6	DDR II	B2			x18	R1Q4A7218ABB-yy			700	630			
7			x36	R1Q4A7236ABB-yy			760	680					
8	QDR II+	B4	2.0	No	x18	R1QAA7218ABB-yy	1220	1160	1070				
9					x36	R1QAA7236ABB-yy	1280	1220	1130				
10	DDR II+	B2			x18	R1QBA7218ABB-yy	1030	990	920				
11					x36	R1QBA7236ABB-yy	1110	1060	990				
12	QDR II+	B4			Yes	x18	R1QDA7218ABB-yy	1220	1160	1070			
13						x36	R1QDA7236ABB-yy	1280	1220	1130			
14	DDR II+	B2	x18	R1QEA7218ABB-yy		1030	990	920					
15			x36	R1QEA7236ABB-yy		1110	1060	990					
16	QDR II+	B4	2.5	No		x18	R1QGA7218ABB-yy			980			
17						x36	R1QGA7236ABB-yy			1060			
18	DDR II+	B2			x18	R1QHA7218ABB-yy			850				
19					x36	R1QHA7236ABB-yy			910				

Notes 1. "yy" represents the speed bin. "R1QDA7236ABB-20" can operate at 500 MHz(max) of frequency, for example.

2. All inputs (except ZQ, V_{REF}) are held at either V_{IH} or V_{IL} .

3. $I_{OUT} = 0$ mA. $V_{DD} = V_{DD} \text{ max}$, $t_{KHKH} = t_{KHKH} \text{ min}$.

4. Operating supply currents (I_{DD}) are measured at 100% bus utilization. I_{DD} of QDR family is current of device with 100% write and 100% read cycle. I_{DD} of DDR family is current of device with 100% write cycle (if $I_{DD}(\text{Write}) > I_{DD}(\text{Read})$) or 100% read cycle (if $I_{DD}(\text{Write}) < I_{DD}(\text{Read})$).

Standby Supply Current (NOP)Symbol = I_{SB1} . Unit = mA.

No	Product Type	Burst Length	Latency (Cycle)	ODT	Organi- zation	Frequency (max) (MHz)	533	500	400	300	250	200		
						Cycle Time (min) (ns)	1.875	2.00	2.50	3.30	4.00	5.00		
						Speed bin	-19	-20	-25	-33	-40			
1	QDR II	B2	1.5	No	x 9	R1Q2A7209ABB-yy					570	510		
2					x18	R1Q2A7218ABB-yy					670	600		
3					x36	R1Q2A7236ABB-yy					710	630		
4		B4			x18	R1Q3A7218ABB-yy			590	520				
5					x36	R1Q3A7236ABB-yy			610	540				
6	DDR II	B2	2.0	No	x18	R1Q4A7218ABB-yy			610	560				
7					x36	R1Q4A7236ABB-yy			670	610				
8	QDR II+	B4			2.0	No	x18	R1QAA7218ABB-yy	870	830	780			
9							x36	R1QAA7236ABB-yy	910	870	810			
10	DDR II+	B2					No	x18	R1QBA7218ABB-yy	870	840	780		
11			x36	R1QBA7236ABB-yy				960	920	860				
12	QDR II+	B4	2.0	Yes	x18	R1QDA7218ABB-yy	870	830	780					
13					x36	R1QDA7236ABB-yy	910	870	810					
14	DDR II+	B2			Yes	x18	R1QEA7218ABB-yy	870	840	780				
15						x36	R1QEA7236ABB-yy	960	920	860				
16	QDR II+	B4	2.5	No	x18	R1QGA7218ABB-yy			720					
17					x36	R1QGA7236ABB-yy			770					
18	DDR II+	B2			No	x18	R1QHA7218ABB-yy			720				
19						x36	R1QHA7236ABB-yy			790				

Notes 1. "yy" represents the speed bin. "R1QDA7236ABB-20" can operate at 500 MHz(max) of frequency, for example.

2. $I_{OUT} = 0$ mA. $V_{DD} = V_{DD\ max}$, $t_{KHKH} = t_{KHKH\ min}$.

3. All address / data inputs are static at either $V_{IN} > V_{IH}$ or $V_{IN} < V_{IL}$.

4. Reference value. (Condition = NOP currents are valid when entering NOP after all pending READ and WRITE cycles are completed.)

Leakage Currents & Output Voltage

Parameter	Symbol	Min	Max	Unit	Test condition	Notes
Input leakage current	I_{LI}	-2	2	μA		10
Output leakage current	I_{LO}	-5	5	μA		11
Output high voltage	V_{OH} (Low)	$V_{DDQ} - 0.2$	V_{DDQ}	V	$ I_{OH} \leq 0.1 \text{ mA}$	8, 9
	V_{OH}	$V_{DDQ}/2 - 0.12$	$V_{DDQ}/2 + 0.12$	V		6, 8, 9
Output low voltage	V_{OL} (Low)	V_{SS}	0.2	V	$I_{OL} \leq 0.1 \text{ mA}$	8, 9
	V_{OL}	$V_{DDQ}/2 - 0.12$	$V_{DDQ}/2 + 0.12$	V		7, 8, 9

Notes 1. All inputs (except ZQ, V_{REF}) are held at either V_{IH} or V_{IL} .

2. $I_{OUT} = 0 \text{ mA}$. $V_{DD} = V_{DD \text{ max}}$, $t_{KHKH} = t_{KHKH \text{ min}}$.

3. Operating supply currents (I_{DD}) are measured at 100% bus utilization. I_{DD} of QDR family is current of device with 100% write and 100% read cycle. I_{DD} of DDR family is current of device with 100% write cycle (if $I_{DD}(\text{Write}) > I_{DD}(\text{Read})$) or 100% read cycle (if $I_{DD}(\text{Write}) < I_{DD}(\text{Read})$).

4. All address / data inputs are static at either $V_{IN} > V_{IH}$ or $V_{IN} < V_{IL}$.

5. Reference value. (Condition = NOP currents are valid when entering NOP after all pending READ and WRITE cycles are completed.)

6. Outputs are impedance-controlled. $|I_{OH}| = (V_{DDQ}/2)/(RQ/5)$ for values of $175 \Omega \leq RQ \leq 350 \Omega$.

7. Outputs are impedance-controlled. $I_{OL} = (V_{DDQ}/2)/(RQ/5)$ for values of $175 \Omega \leq RQ \leq 350 \Omega$.

8. AC load current is higher than the shown DC values. AC I/O curves are available upon request.

9. HSTL outputs meet JEDEC HSTL Class I and Class II standards.

10. $0 \leq V_{IN} \leq V_{DDQ}$ for all input balls (except V_{REF} , ZQ, TCK, TMS, TDI ball).

11. $0 \leq V_{OUT} \leq V_{DDQ}$ (except TDO ball), output disabled.

Thermal Resistance

Parameter	Symbol	Airflow	Typ	Unit	Test condition	Notes
Junction to Ambient	θ_{JA}	1 m/s	11.0	$^{\circ}\text{C}/\text{W}$	EIA/JEDEC JESD51	1
Junction to Case	θ_{JC}	-	4.4			

Notes 1. These parameters are calculated under the condition. These are reference values.

$$2. T_j = T_a + \theta_{JA} \times P_d$$

$$T_j = T_c + \theta_{JC} \times P_d$$

where

T_j : Junction temperature when the device has achieved a steady-state after application of P_d ($^{\circ}\text{C}$)

T_a : Ambient temperature ($^{\circ}\text{C}$)

T_c : Temperature of external surface of the package or case ($^{\circ}\text{C}$)

θ_{JA} : Thermal resistance from junction-to-ambient ($^{\circ}\text{C}/\text{W}$)

θ_{JC} : Thermal resistance from junction-to-case (package) ($^{\circ}\text{C}/\text{W}$)

P_d : Power dissipation that produced change in junction temperature (W) (cf. JESD51-2A)

Capacitance

$T_a = +25^\circ\text{C}$, Frequency = 1.0MHz, $V_{DD} = 1.8\text{V}$, $V_{DDQ} = 1.5\text{V}$

Parameter	Symbol	Min	Typ	Max	Unit	Test condition	Notes
Input capacitance (SA, /R, /W, /BW, D _(separate))	C_{IN}	-	4	5	pF	$V_{IN} = 0\text{V}$	1, 2
Clock input capacitance (K, /K, C, /C)	C_{CLK}	-	4	5	pF	$V_{CLK} = 0\text{V}$	1, 2
Output capacitance (Q _(separate) , DQ _(common) , CQ, /CQ)	$C_{I/O}$	-	5	6	pF	$V_{I/O} = 0\text{V}$	1, 2

Notes 1. These parameters are sampled and not 100% tested.

2. Except JTAG (TCK, TMS, TDI, TDO) pins.

AC Test Conditions

Input waveform

Rise/fall time $\leq 0.3\text{ ns}$

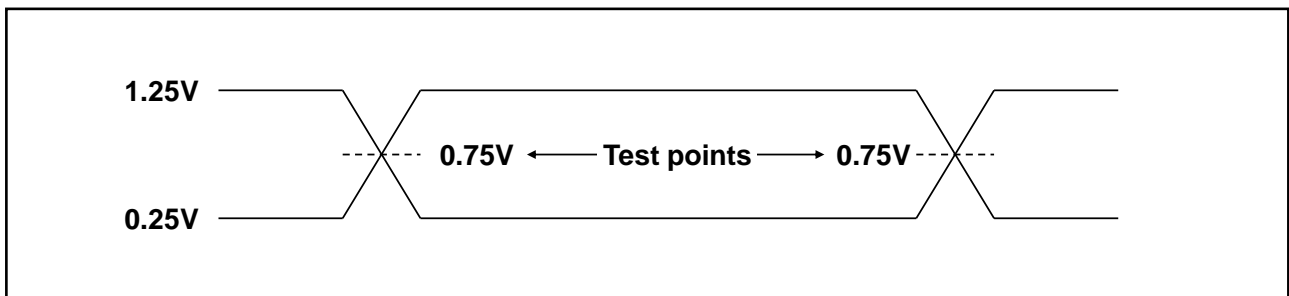

Output waveform

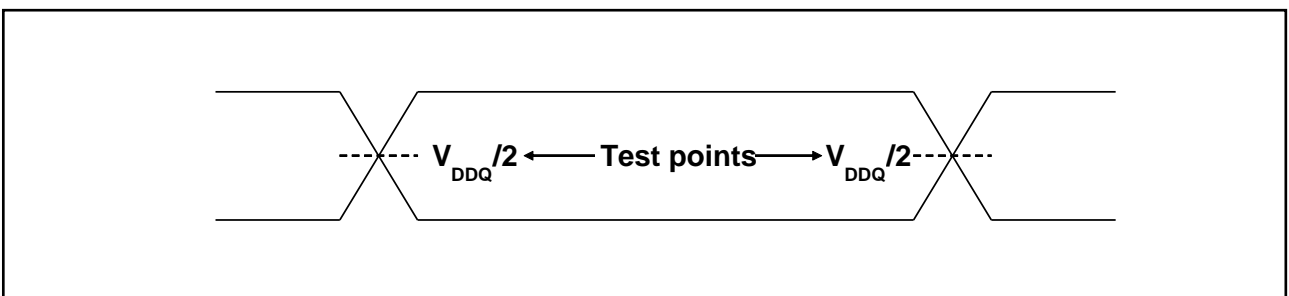

Output load conditions

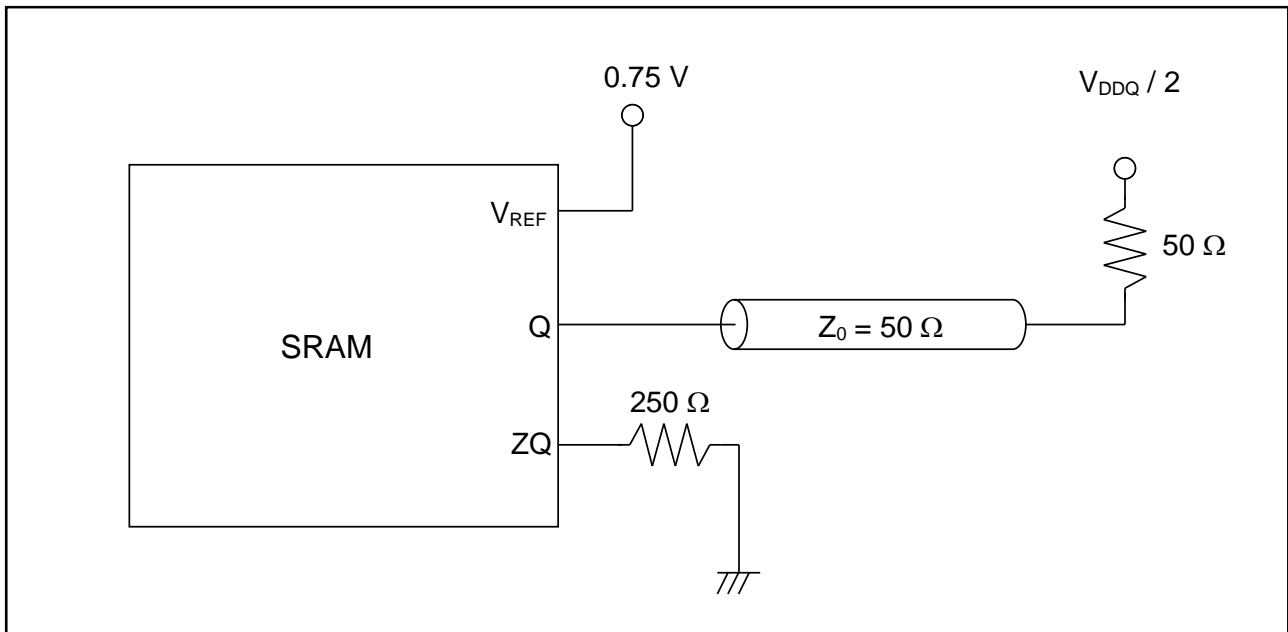

AC Operating Conditions

Parameter	Symbol	Min	Typ	Max	Unit	Notes
Input high voltage	$V_{IH(AC)}$	$V_{REF} + 0.2$	-	-	V	1, 2, 3, 4
Input low voltage	$V_{IL(AC)}$	-	-	$V_{REF} - 0.2$	V	1, 2, 3, 4

Notes 1. All voltages referenced to V_{SS} (GND).

During normal operation, V_{DDQ} must not exceed V_{DD} .

2. These conditions are for AC functions only, not for AC parameter test.

3. Overshoot: $V_{IH(AC)} \leq V_{DDQ} + 0.5 \text{ V}$ for $t \leq t_{KHKH}/2$

Undershoot: $V_{IL(AC)} \geq -0.5 \text{ V}$ for $t \leq t_{KHKL}/2$

Control input signals may not have pulse widths less than $t_{KHKL}(\text{min})$ or operate at cycle rates less than $t_{KHKH}(\text{min})$.

4. To maintain a valid level, the transitioning edge of the input must:

a. Sustain a constant slew rate from the current AC level through the target AC level, $V_{IL(AC)}$ or $V_{IH(AC)}$.

b. Reach at least the target AC level.

c. After the AC target level is reached, continue to maintain at least the target DC level, $V_{IL(DC)}$ or $V_{IH(DC)}$.

AC Characteristics (QDR-II, DDR-II series)

Ta = -40 ~ +85°C

V_{DD} = 1.8V ±0.1V, V_{DDQ} = 1.5V, V_{REF} = 0.75V

Parameter	Symbol	-33		-40				Unit	Notes
		300 MHz		250 MHz		200 MHz			
		Min	Max	Min	Max	Min	Max		
Clock									
Average clock cycle time (K, /K, C, /C)	t _{KHKH}	3.30	8.40	4.00	8.40	5.00	8.40	ns	8
Clock high time (K, /K, C, /C)	t _{KHKL}	1.32	-	1.60	-	2.00	-	ns	
Clock low time (K, /K, C, /C)	t _{KLKH}	1.32	-	1.60	-	2.00	-	ns	
Clock to /clock (K to /K, C to /C)	t _{KH/KH}	1.49	-	1.80	-	2.20	-	ns	
/Clock to clock (/K to K, /C to C)	t _{/KHKH}	1.49	-	1.80	-	2.20	-	ns	
Clock to data clock (K to C, /K to /C)	t _{KHCH}	0	1.49	0	1.80	0	2.20	ns	
DLL / PLL timing									
Clock phase jitter (K, /K, C, /C)	t _{KC var}	-	0.20	-	0.20	-	0.20	ns	3
Lock time (K, C)	t _{KC lock}	1024	-	1024	-	1024	-	Cycle	2
K static to DLL/PLL reset	t _{KC reset}	30	-	30	-	30	-	ns	7
Output times									
C, /C high to output valid	t _{CHQV}	-	0.45	-	0.45	-	0.45	ns	9
C, /C high to output hold	t _{CHQX}	-0.45	-	-0.45	-	-0.45	-	ns	9
C, /C high to echo clock valid	t _{CHCQV}	-	0.45	-	0.45	-	0.45	ns	9
C, /C high to echo clock hold	t _{CHCQX}	-0.45	-	-0.45	-	-0.45	-	ns	9
CQ, /CQ high to output valid	t _{CQHQV}	-	0.27	-	0.30	-	0.35	ns	4, 7
CQ, /CQ high to output hold	t _{CQHQX}	-0.27	-	-0.30	-	-0.35	-	ns	4, 7
C, /C high to output high-Z	t _{CHQZ}	-	0.45	-	0.45	-	0.45	ns	5, 6, 9
C, /C high to output low-Z	t _{CHQX1}	-0.45	-	-0.45	-	-0.45	-	ns	5, 9

Parameter	Symbol	-33		-40				Unit	Notes
		300 MHz		250 MHz		200 MHz			
		Min	Max	Min	Max	Min	Max		
Setup times									
Address valid to K rising edge	t_{AVKH} for R1Q2	-	-	0.35	-	0.40	-	ns	1
	t_{AVKH} for R1Q3/4	0.40	-	0.50	-	0.60	-		
Control inputs valid to K rising edge	t_{IVKH} for R1Q2	-	-	0.35	-	0.40	-	ns	1
	t_{IVKH} for R1Q3/4	0.40	-	0.50	-	0.60	-		
Data-in valid to K, /K rising edge	t_{DVKH}	0.30	-	0.35	-	0.40	-	ns	1
Hold times									
K rising edge to address hold	t_{KHAX} for R1Q2	-	-	0.35	-	0.40	-	ns	1
	t_{KHAX} for R1Q3/4	0.40	-	0.50	-	0.60	-		
K rising edge to control inputs hold	t_{KHIX} for R1Q2	-	-	0.35	-	0.40	-	ns	1
	t_{KHIX} for R1Q3/4	0.40	-	0.50	-	0.60	-		
K, /K rising edge to data-in hold	t_{KHDX}	0.30	-	0.35	-	0.40	-	ns	1

- Notes 1.** This is a synchronous device. All addresses, data and control lines must meet the specified setup and hold times for all latching clock edges.
- 2.** V_{DD} and V_{DDQ} slew rate must be less than 0.1 V DC per 50 ns for DLL/PLL lock retention. DLL/PLL lock time begins once V_{DD} , V_{DDQ} and input clock are stable. It is recommended that the device is kept inactive during these cycles. This specification meets the QDR common spec. of 20 us.
- 3.** Clock phase jitter is the variance from clock rising edge to the next expected clock rising edge.
- 4.** Echo clock is very tightly controlled to data valid / data hold. By design, there is a ± 0.1 ns variation from echo clock to data. The datasheet parameters reflect tester guardbands and test setup variations.
- 5.** Transitions are measured ± 100 mV from steady-state voltage.
- 6.** At any given voltage and temperature t_{CHQZ} is less than t_{CHQX1} and t_{CHQV} .
- 7.** These parameters are sampled.
- 8.** When x18 and x36 configuration except QDR II-B2 are operated at less than 180MHz, DLL/PLL should be disabled (/DOFF=L). Please contact Renesas if these devices are always used at less than 180MHz with DLL/PLL operation.
- 9.** t_{CHQV} , t_{CHQX} , t_{CHCQV} , t_{CHCQX} , t_{CHQZ} and t_{CHQX1} spec of R1Q3A and R1Q4A series are determined by the actual frequency regardless of Part Number (Marking Name). The following is the spec for the actual frequency.

$$t_{CHQV}, t_{CHCQV}, t_{CHQZ} = 0.45 \text{ ns for } \geq 200 \text{ MHz and } 0.50 \text{ ns for } < 200 \text{ MHz}$$

$$t_{CHQX}, t_{CHCQX}, t_{CHQX1} = -0.45 \text{ ns for } \geq 200 \text{ MHz and } -0.50 \text{ ns for } < 200 \text{ MHz}$$

- Remarks 1.** Test conditions as specified with the output loading as shown in AC Test Conditions unless otherwise noted.
2. Control input signals may not be operated with pulse widths less than t_{KHKL} (min).
 3. If C and /C are tied high, K and /K become the references for C and /C timing parameters.
 4. V_{DDQ} is +1.5 V DC. V_{REF} is +0.75 V DC.
 5. Control signals are /R, /W (QDR series), /LD, R-/W (DDR series), /BW, /BW0, /BW1, /BW2 and /BW3. Setup and hold times of /BWx signals must be the same as those of Data-in signals.

Timing Waveforms

Read and Write Timing (DDRII, B2, Read Latency = 1.5 cycle)

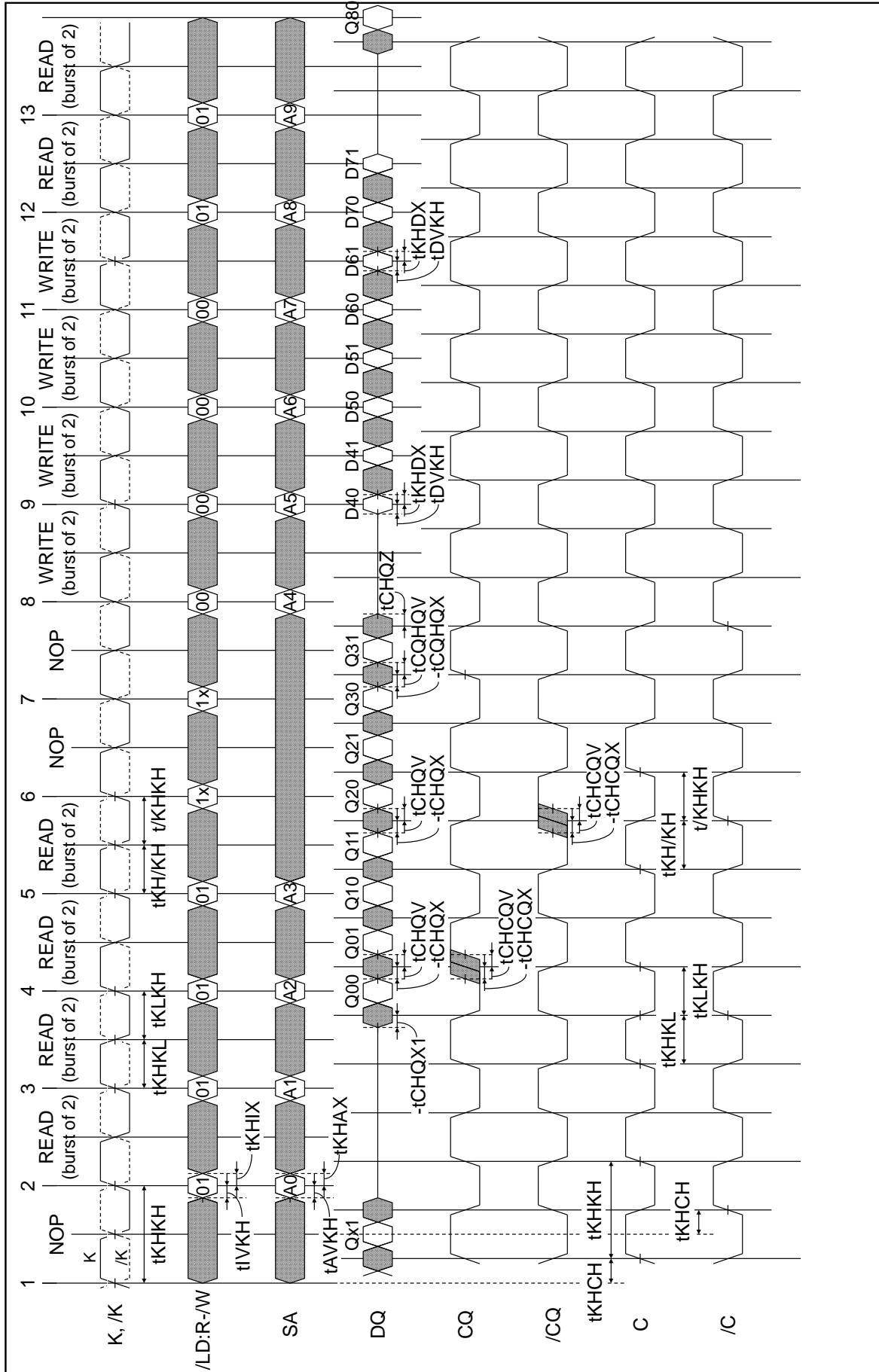

- Notes**
1. Q00 refers to output from address A0. Q01 refers to output from the next internal burst address following A0, etc.
 2. Outputs are disabled (High-Z) N clock cycle after the last read cycle. Here, $N = \text{Read Latency} + \text{Burst Length} \times 0.5$.
 3. In this example, if address A8 = A7, then data Q80 = D70, Q81 = D71, etc. Write data is forwarded immediately as read results.
 4. To control read and write operations, $\overline{\text{BW}}$ signals must operate at the same timing as Data-in signals.
 5. The second NOP cycle is not necessary for correct device operation; however, at high clock frequencies it may be required to prevent bus contention.

JTAG Specification

These products support a limited set of JTAG functions as in IEEE standard 1149.1.

Disabling the Test Access Port

It is possible to use this device without utilizing the TAP. To disable the TAP controller without interfering with normal operation of the device, TCK must be tied to V_{SS} to preclude mid level inputs.

TDI and TMS are internally pulled up and may be unconnected, or may be connected to V_{DD} through a pull up resistor.

TDO should be left unconnected.

Test Access Port (TAP) Pins

Symbol I/O	Pin assignments	Description	Notes
TCK	2R	Test clock input. All inputs are captured on the rising edge of TCK and all outputs propagate from the falling edge of TCK.	
TMS	10R	Test mode select. This is the command input for the TAP controller state machine.	
TDI	11R	Test data input. This is the input side of the serial registers placed between TDI and TDO. The register placed between TDI and TDO is determined by the state of the TAP controller state machine and the instruction that is currently loaded in the TAP instruction.	
TDO	1R	Test data output. Output changes in response to the falling edge of TCK. This is the output side of the serial registers placed between TDI and TDO.	

- Note 1.** The device does not have TRST (TAP reset). The Test-Logic Reset state is entered while TMS is held high for five rising edges of TCK. The TAP controller state is also reset on SRAM POWER-UP.

TAP DC Operating Characteristics $T_a = -40 \sim +85^\circ\text{C}$ $V_{DD} = 1.8\text{V} \pm 0.1\text{V}$

Parameter	Symbol	Min	Typ	Max	Unit	Notes
Input high voltage	V_{IH}	+1.3	-	$V_{DD} + 0.3$	V	
Input low voltage	V_{IL}	-0.3	-	+0.5	V	
Input leakage current	I_{LI}	-5.0	-	+5.0	μA	$0\text{V} \leq V_{IN} \leq V_{DD}$
Output leakage current	I_{LO}	-5.0	-	+5.0	μA	$0\text{V} \leq V_{IN} \leq V_{DD}$, output disabled
Output low voltage	V_{OL1}	-	-	0.2	V	$I_{OLC} = 100\ \mu\text{A}$
	V_{OL2}	-	-	0.4	V	$I_{OLT} = 2\ \text{mA}$
Output high voltage	V_{OH1}	1.6	-	-	V	$ I_{OHC} = 100\ \mu\text{A}$
	V_{OH2}	1.4	-	-	V	$ I_{OHT} = 2\ \text{mA}$

Notes 1. All voltages referenced to V_{SS} (GND).

- 2.** At power-up, V_{DD} and V_{DDQ} are assumed to be a linear ramp from 0V to $V_{DD}(\text{min.})$ or $V_{DDQ}(\text{min.})$ within 200ms. During this time $V_{DDQ} < V_{DD}$ and $V_{IH} < V_{DDQ}$. During normal operation, V_{DDQ} must not exceed V_{DD} .

TAP AC Test Conditions

Parameter	Symbol	Conditions	Unit	Notes
Input timing measurement reference levels	V_{REF}	0.9	V	
Input pulse levels	V_{IL}, V_{IH}	0 to 1.8	V	
Input rise/fall time	t_r, t_f	≤ 1.0	ns	
Output timing measurement reference levels		0.9	V	
Test load termination supply voltage (V_{TT})		0.9	V	
Output load		See figures		

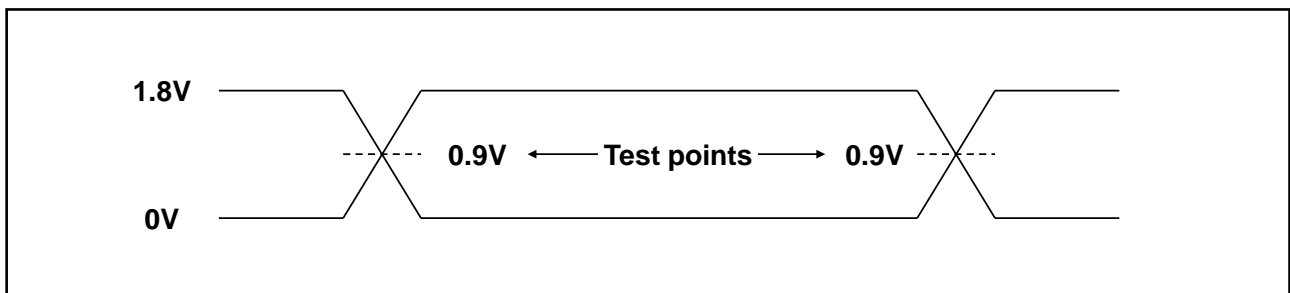
Input waveform

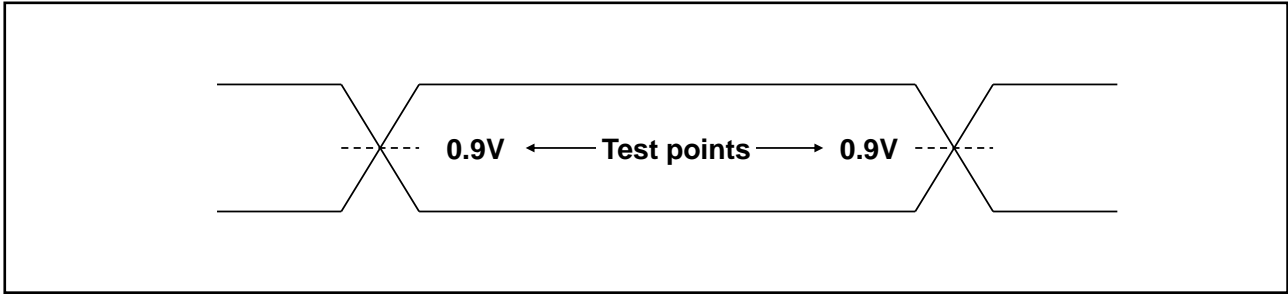
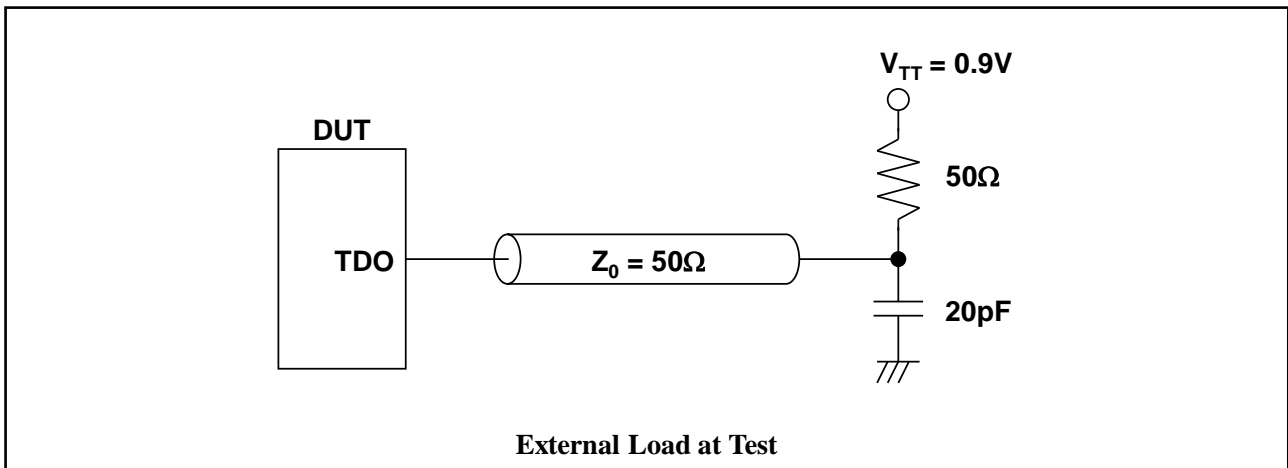
Output waveform**Output load condition****TAP AC Operating Characteristics**

$T_a = -40 \sim +85^\circ\text{C}$

$V_{DD} = 1.8V \pm 0.1V$

Parameter	Symbol	Min	Typ	Max	Unit	Notes
Test clock (TCK) cycle time	t_{THTH}	50	-	-	ns	
TCK high pulse width	t_{HTHL}	20	-	-	ns	
TCK low pulse width	t_{LTH}	20	-	-	ns	
Test mode select (TMS) setup	t_{MVTH}	5	-	-	ns	
TMS hold	t_{THMX}	5	-	-	ns	
Capture setup	t_{CS}	5	-	-	ns	1
Capture hold	t_{CH}	5	-	-	ns	1
TDI valid to TCK high	t_{DVTH}	5	-	-	ns	
TCK high to TDI invalid	t_{THDX}	5	-	-	ns	
TCK low to TDO unknown	t_{TLQX}	0	-	-	ns	
TCK low to TDO valid	t_{TLQV}	-	-	10	ns	

Note 1. $t_{CS} + t_{CH}$ defines the minimum pause in RAM I/O pad transitions to assure pad data capture.

TAP Controller Timing Diagram

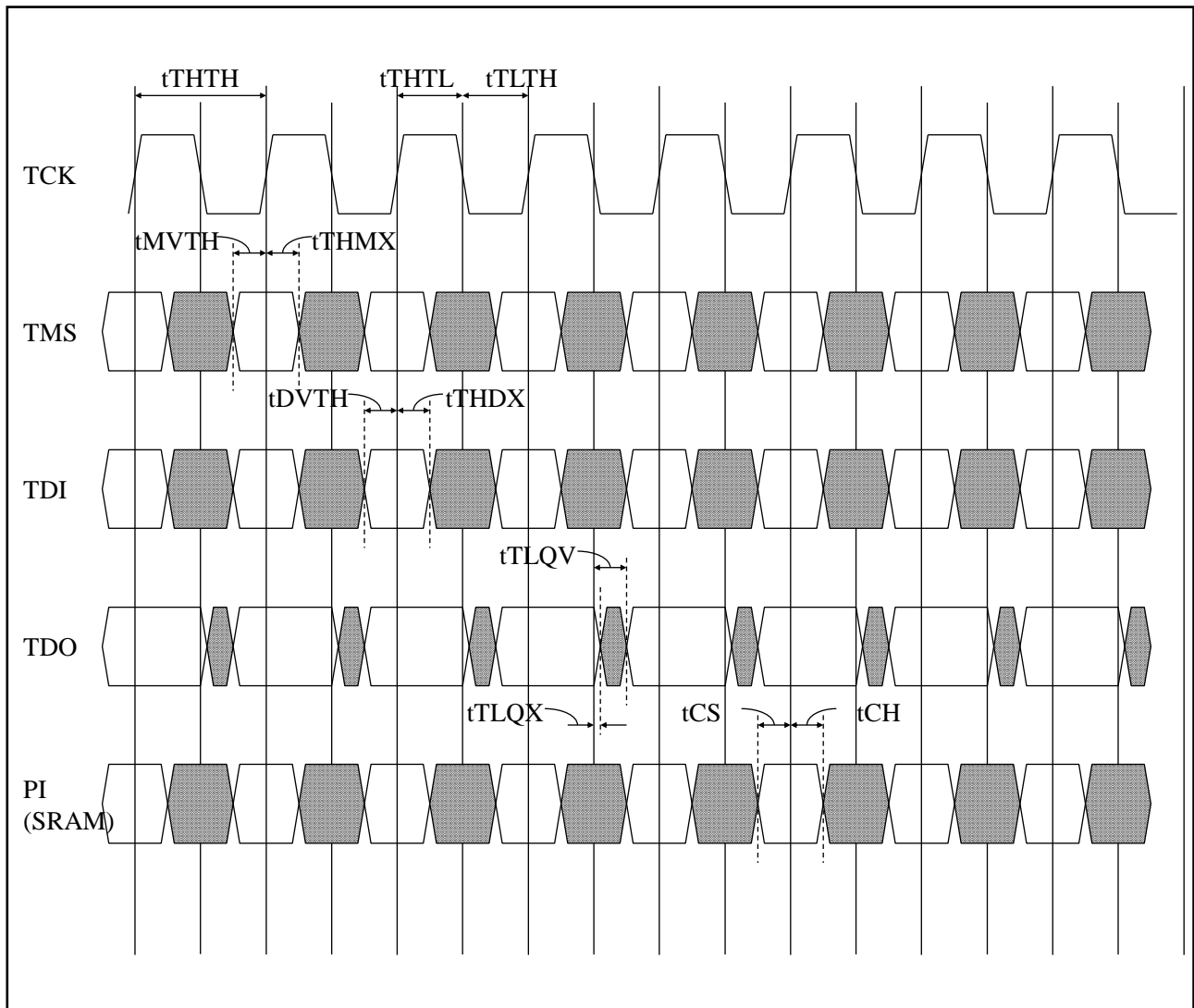

Test Access Port Registers

Register name	Length	Symbol	Notes
Instruction register	3 bits	IR [2:0]	
Bypass register	1 bit	BP	
ID register	32 bits	ID [31:0]	
Boundary scan register	109 bits	BS [109:1]	

TAP Controller Instruction Set

IR2	IR1	IR0	Instruction	Description	Notes
0	0	0	EXTEST	The EXTEST instruction allows circuitry external to the component package to be tested. Boundary scan register cells at output balls are used to apply test vectors, while those at input balls capture test results. Typically, the first test vector to be applied using the EXTEST instruction will be shifted into the boundary scan register using the PRELOAD instruction. Thus, during the Update-IR state of EXTEST, the output driver is turned on and the PRELOAD data is driven onto the output balls.	1, 2, 3, 5
0	0	1	IDCODE	The IDCODE instruction causes the ID ROM to be loaded into the ID register when the controller is in capture-DR mode and places the ID register between the TDI and TDO balls in shift-DR mode. The IDCODE instruction is the default instruction loaded in at power up and any time the controller is placed in the Test-Logic-Reset state.	
0	1	0	SAMPLE-Z	If the SAMPLE-Z instruction is loaded in the instruction register, all RAM outputs are forced to an inactive drive state (High-Z), moving the TAP controller into the capture-DR state loads the data in the RAMs input into the boundary scan register, and the boundary scan register is connected between TDI and TDO when the TAP controller is moved to the shift-DR state.	3, 4, 5
0	1	1	RESERVED	The RESERVED instructions are not implemented but are reserved for future use. Do not use these instructions.	
1	0	0	SAMPLE (/PRELOAD)	When the SAMPLE instruction is loaded in the instruction register, moving the TAP controller into the capture-DR state loads the data in the RAMs input and I/O buffers into the boundary scan register. Because the RAM clock(s) are independent from the TAP clock (TCK) it is possible for the TAP to attempt to capture the I/O ring contents while the input buffers are in transition (i.e., in a metastable state). Although allowing the TAP to SAMPLE metastable input will not harm the device, repeatable results cannot be expected. Moving the controller to shift-DR state then places the boundary scan register between the TDI and TDO balls.	3, 5
1	0	1	RESERVED	-	
1	1	0	RESERVED	-	
1	1	1	BYPASS	The BYPASS instruction is loaded in the instruction register when the bypass register is placed between TDI and TDO. This occurs when the TAP controller is moved to the shift-DR state. This allows the board level scan path to be shortened to facilitate testing of other devices in the scan path.	

Notes 1. Data in output register is not guaranteed if EXTEST instruction is loaded.

2. After performing EXTEST, power-up conditions are required in order to return part to normal operation.
3. RAM input signals must be stabilized for long enough to meet the TAPs input data capture setup plus hold time (t_{CS} plus t_{CH}). The RAMs clock inputs need not be paused for any other TAP operation except capturing the I/O ring contents into the boundary scan register.
4. Clock recovery initialization cycles are required after boundary scan.
5. For R1QD and R1QE series, ODT is disabled in EXTEST, SAMPLE-Z or SAMPLE mode.

Boundary Scan Order

Bit #	Ball ID	Signal names		Bit #	Ball ID	Signal names	
		x18	x36			x18	x36
1	6R	/C	/C	36	10E	NC	DQ15
2	6P	C	C	37	10D	NC	NC
3	6N	SA	SA	38	9E	NC	NC
4	7P	SA	SA	39	10C	DQ7	DQ17
5	7N	SA	SA	40	11D	NC	DQ16
6	7R	SA	SA	41	9C	NC	NC
7	8R	SA	SA	42	9D	NC	NC
8	8P	SA	SA	43	11B	DQ8	DQ8
9	9R	SA	SA	44	11C	NC	DQ7
10	11P	DQ0	DQ0	45	9B	NC	NC
11	10P	NC	DQ9	46	10B	NC	NC
12	10N	NC	NC	47	11A	CQ	CQ
13	9P	NC	NC	48	10A	SA	SA
14	10M	DQ1	DQ11	49	9A	SA	SA
15	11N	NC	DQ10	50	8B	SA	SA
16	9M	NC	NC	51	7C	SA	SA
17	9N	NC	NC	52	6C	SA0	SA0
18	11L	DQ2	DQ2	53	8A	/LD	/LD
19	11M	NC	DQ1	54	7A	NC	/BW1
20	9L	NC	NC	55	7B	/BW0	/BW0
21	10L	NC	NC	56	6B	K	K
22	11K	DQ3	DQ3	57	6A	/K	/K
23	10K	NC	DQ12	58	5B	NC	/BW3
24	9J	NC	NC	59	5A	/BW1	/BW2
25	9K	NC	NC	60	4A	R-/W	R-/W
26	10J	DQ4	DQ13	61	5C	SA	SA
27	11J	NC	DQ4	62	4B	SA	SA
28	11H	ZQ	ZQ	63	3A	SA	SA
29	10G	NC	NC	64	2A	SA	NC
30	9G	NC	NC	65	1A	/CQ	/CQ
31	11F	DQ5	DQ5	66	2B	DQ9	DQ27
32	11G	NC	DQ14	67	3B	NC	DQ18
33	9F	NC	NC	68	1C	NC	NC
34	10F	NC	NC	69	1B	NC	NC
35	11E	DQ6	DQ6	70	3D	DQ10	DQ19

Bit #	Ball ID	Signal names		Bit #	Ball ID	Signal names	
		x18	x36			x18	x36
71	3C	NC	DQ28	91	2L	DQ15	DQ33
72	1D	NC	NC	92	3L	NC	DQ24
73	2C	NC	NC	93	1M	NC	NC
74	3E	DQ11	DQ20	94	1L	NC	NC
75	2D	NC	DQ29	95	3N	DQ16	DQ25
76	2E	NC	NC	96	3M	NC	DQ34
77	1E	NC	NC	97	1N	NC	NC
78	2F	DQ12	DQ30	98	2M	NC	NC
79	3F	NC	DQ21	99	3P	DQ17	DQ26
80	1G	NC	NC	100	2N	NC	DQ35
81	1F	NC	NC	101	2P	NC	NC
82	3G	DQ13	DQ22	102	1P	NC	NC
83	2G	NC	DQ31	103	3R	SA	SA
84	1H	/DOFF	/DOFF	104	4R	SA	SA
85	1J	NC	NC	105	4P	SA	SA
86	2J	NC	NC	106	5P	SA	SA
87	3K	DQ14	DQ23	107	5N	SA	SA
88	3J	NC	DQ32	108	5R	SA	SA
89	2K	NC	NC	109	-	Internal	Internal
90	1K	NC	NC				

Notes In boundary scan mode,

1. Clock balls (K, /K, C, /C) are referenced to each other and must be at opposite logic levels for reliable operation.
2. CQ and /CQ data are synchronized to the respective C and /C (except EXTEST, SAMPLE-Z).
3. If C and /C tied high, CQ is generated with respect to K and /CQ is generated with respect to /K (except EXTEST, SAMPLE-Z).

Package Dimensions and Marking Information

JEITA Package Code	Renesas Code	Previous Code	Mass (typ.)
P-LBGA165-13x15-1.00	PLBG0165FE-A	165FHG	0.5g

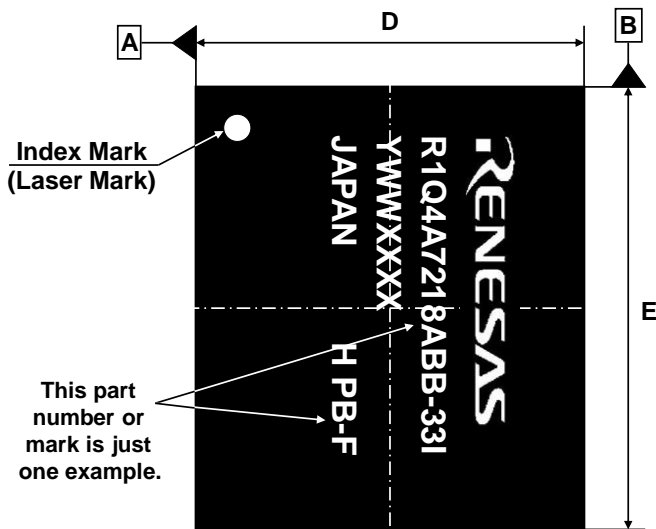

Top View

Marking Information

- 1st row : Vender name (RENESAS)
- 2nd row: Part number
- 3rd row : Y : Year code
WW : Week code
XXXX : Renesas
 internal use
- 4th row : Country name (JAPAN)
+ "H" --- Non-Halogenated
+ "PB-F" --- Pb-free parts

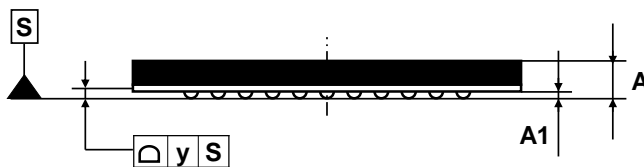

Side View

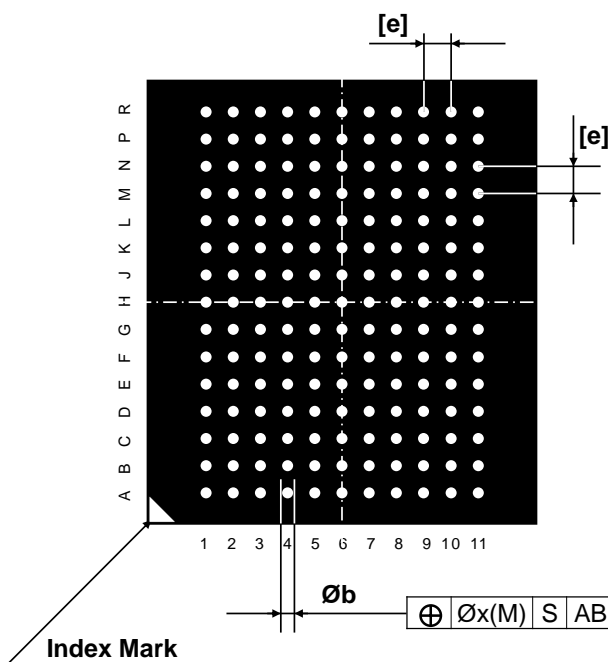

Bottom View

Reference Symbol	Dimension in mm		
	Min	Nom	Max
D	12.9	13.0	13.1
E	14.9	15.0	15.1
A	-	-	1.4
A1	0.31	0.36	0.41
[e]	-	1.0	-
b	0.45	0.5	0.6
x	-	-	0.2
y	-	-	0.15

Revision History**R1Q4A7236ABB, R1Q4A7218ABB**

Rev.	Date	Description	
		Page	Summary
1.00	-	-	Applied new document format.
2.00	'17.05.15	-	Reflected the information related change to non-halogenated package and merger some speed bin.
2.01	'17.06.09	P.6-7 P.11 P.17 -	Fixed Pin Description. Added Burst Sequence. Added description of Pd. Fixed some typo.
2.02	'18.12.01	P.11 P.29	Fixed K Truth Table Fixed Boundary Scan Order Table
2.03	'19.02.01	-	Deleted description other than current Renesas 72M QDR Lineup. Fixed some typo and orthographical variants.

Notice

1. Descriptions of circuits, software and other related information in this document are provided only to illustrate the operation of semiconductor products and application examples. You are fully responsible for the incorporation or any other use of the circuits, software, and information in the design of your product or system. Renesas Electronics disclaims any and all liability for any losses and damages incurred by you or third parties arising from the use of these circuits, software, or information.
2. Renesas Electronics hereby expressly disclaims any warranties against and liability for infringement or any other claims involving patents, copyrights, or other intellectual property rights of third parties, by or arising from the use of Renesas Electronics products or technical information described in this document, including but not limited to, the product data, drawings, charts, programs, algorithms, and application examples.
3. No license, express, implied or otherwise, is granted hereby under any patents, copyrights or other intellectual property rights of Renesas Electronics or others.
4. You shall not alter, modify, copy, or reverse engineer any Renesas Electronics product, whether in whole or in part. Renesas Electronics disclaims any and all liability for any losses or damages incurred by you or third parties arising from such alteration, modification, copying or reverse engineering.
5. Renesas Electronics products are classified according to the following two quality grades: "Standard" and "High Quality". The intended applications for each Renesas Electronics product depends on the product's quality grade, as indicated below.
"Standard": Computers; office equipment; communications equipment; test and measurement equipment; audio and visual equipment; home electronic appliances; machine tools; personal electronic equipment; industrial robots; etc.
"High Quality": Transportation equipment (automobiles, trains, ships, etc.); traffic control (traffic lights); large-scale communication equipment; key financial terminal systems; safety control equipment; etc.
Unless expressly designated as a high reliability product or a product for harsh environments in a Renesas Electronics data sheet or other Renesas Electronics document, Renesas Electronics products are not intended or authorized for use in products or systems that may pose a direct threat to human life or bodily injury (artificial life support devices or systems; surgical implantations; etc.), or may cause serious property damage (space system; undersea repeaters; nuclear power control systems; aircraft control systems; key plant systems; military equipment; etc.). Renesas Electronics disclaims any and all liability for any damages or losses incurred by you or any third parties arising from the use of any Renesas Electronics product that is inconsistent with any Renesas Electronics data sheet, user's manual or other Renesas Electronics document.
6. When using Renesas Electronics products, refer to the latest product information (data sheets, user's manuals, application notes, "General Notes for Handling and Using Semiconductor Devices" in the reliability handbook, etc.), and ensure that usage conditions are within the ranges specified by Renesas Electronics with respect to maximum ratings, operating power supply voltage range, heat dissipation characteristics, installation, etc. Renesas Electronics disclaims any and all liability for any malfunctions, failure or accident arising out of the use of Renesas Electronics products outside of such specified ranges.
7. Although Renesas Electronics endeavors to improve the quality and reliability of Renesas Electronics products, semiconductor products have specific characteristics, such as the occurrence of failure at a certain rate and malfunctions under certain use conditions. Unless designated as a high reliability product or a product for harsh environments in a Renesas Electronics data sheet or other Renesas Electronics document, Renesas Electronics products are not subject to radiation resistance design. You are responsible for implementing safety measures to guard against the possibility of bodily injury, injury or damage caused by fire, and/or danger to the public in the event of a failure or malfunction of Renesas Electronics products, such as safety design for hardware and software, including but not limited to redundancy, fire control and malfunction prevention, appropriate treatment for aging degradation or any other appropriate measures. Because the evaluation of microcomputer software alone is very difficult and impractical, you are responsible for evaluating the safety of the final products or systems manufactured by you.
8. Please contact a Renesas Electronics sales office for details as to environmental matters such as the environmental compatibility of each Renesas Electronics product. You are responsible for carefully and sufficiently investigating applicable laws and regulations that regulate the inclusion or use of controlled substances, including without limitation, the EU RoHS Directive, and using Renesas Electronics products in compliance with all these applicable laws and regulations. Renesas Electronics disclaims any and all liability for damages or losses occurring as a result of your noncompliance with applicable laws and regulations.
9. Renesas Electronics products and technologies shall not be used for or incorporated into any products or systems whose manufacture, use, or sale is prohibited under any applicable domestic or foreign laws or regulations. You shall comply with any applicable export control laws and regulations promulgated and administered by the governments of any countries asserting jurisdiction over the parties or transactions.
10. It is the responsibility of the buyer or distributor of Renesas Electronics products, or any other party who distributes, disposes of, or otherwise sells or transfers the product to a third party, to notify such third party in advance of the contents and conditions set forth in this document.
11. This document shall not be reprinted, reproduced or duplicated in any form, in whole or in part, without prior written consent of Renesas Electronics.
12. Please contact a Renesas Electronics sales office if you have any questions regarding the information contained in this document or Renesas Electronics products.
(Note 1) "Renesas Electronics" as used in this document means Renesas Electronics Corporation and also includes its directly or indirectly controlled subsidiaries.
(Note 2) "Renesas Electronics product(s)" means any product developed or manufactured by or for Renesas Electronics.

(Rev.4.0-1 November 2017)



SALES OFFICES

Renesas Electronics Corporation

<http://www.renesas.com>

Refer to "<http://www.renesas.com/>" for the latest and detailed information.

Renesas Electronics Corporation
TOYOSU FORESIA, 3-2-24 Toyosu, Koto-ku, Tokyo 135-0061, Japan

Renesas Electronics America Inc.
1001 Murphy Ranch Road, Milpitas, CA 95035, U.S.A.
Tel: +1-408-432-8888, Fax: +1-408-434-5351

Renesas Electronics Canada Limited
9251 Yonge Street, Suite 8309 Richmond Hill, Ontario Canada L4C 9T3
Tel: +1-905-237-2004

Renesas Electronics Europe Limited
Dukes Meadow, Millboard Road, Bourne End, Buckinghamshire, SL8 5FH, U.K
Tel: +44-1628-651-700

Renesas Electronics Europe GmbH
Arcadiastrasse 10, 40472 Düsseldorf, Germany
Tel: +49-211-6503-0, Fax: +49-211-6503-1327

Renesas Electronics (China) Co., Ltd.
Room 1709 Quantum Plaza, No.27 ZhichunLu, Haidian District, Beijing, 100191 P. R. China
Tel: +86-10-8235-1155, Fax: +86-10-8235-7679

Renesas Electronics (Shanghai) Co., Ltd.
Unit 301, Tower A, Central Towers, 555 Langao Road, Putuo District, Shanghai, 200333 P. R. China
Tel: +86-21-2226-0888, Fax: +86-21-2226-0999

Renesas Electronics Hong Kong Limited
Unit 1601-1611, 16/F., Tower 2, Grand Century Place, 193 Prince Edward Road West, Mongkok, Kowloon, Hong Kong
Tel: +852-2265-6688, Fax: +852 2886-9022

Renesas Electronics Taiwan Co., Ltd.
13F, No. 363, Fu Shing North Road, Taipei 10543, Taiwan
Tel: +886-2-8175-9600, Fax: +886 2-8175-9670

Renesas Electronics Singapore Pte. Ltd.
80 Bendemeer Road, Unit #06-02 Hyflux Innovation Centre, Singapore 339949
Tel: +65-6213-0200, Fax: +65-6213-0300

Renesas Electronics Malaysia Sdn.Bhd.
Unit 1207, Block B, Menara Amcorp, Amcorp Trade Centre, No. 18, Jln Persiaran Barat, 46050 Petaling Jaya, Selangor Darul Ehsan, Malaysia
Tel: +60-3-7955-9390, Fax: +60-3-7955-9510

Renesas Electronics India Pvt. Ltd.
No.777C, 100 Feet Road, HAL 2nd Stage, Indiranagar, Bangalore 560 038, India
Tel: +91-80-67208700, Fax: +91-80-67208777

Renesas Electronics Korea Co., Ltd.
17F, KAMCO Yangjae Tower, 262, Gangnam-daero, Gangnam-gu, Seoul, 06265 Korea
Tel: +82-2-558-3737, Fax: +82-2-558-5338