

SLG46540

GreenPAK Programmable Mixed-Signal Matrix with 4-bit I²C IO Expander

Description

The SLG46540 is a small, low power 4-bit IO expander for I²C bus integrated with commonly used Mixed-Signal functions. The user creates their circuit design by programming the one-time Non-Volatile Memory (NVM) to configure the interconnect logic, the IO Pins, and the macrocells of the SLG46540. This highly versatile device allows a wide variety of Mixed-Signal functions to be designed within a very small, low power single integrated circuit.

Features

- Three Analog Comparators (ACMP)
- Nineteen Combination Function Macrocells
 - Three Selectable DFF/LATCH or 2-bit LUTs
 - One Selectable Continuous DFF/LATCH or 3-bit LUT
 - Four Selectable DFF/LATCH or 3-bit LUTs
 - One Selectable Pipe Delay or 3-bit LUT
 - One Selectable Programmable Function Generator or 2-bit LUT
 - Five 8-bit Delays/Counters or 3-bit LUTs
 - Two 16-bit Delays/Counters or 4-bit LUTs
 - Two Deglitch Filters with Edge Detectors
- Serial Communications
 - I²C Protocol Compliant
- Pipe Delay – 16 Stage/3 Output (Part of Combination Function Macrocell)
- Programmable Delay
- Two Oscillators (OSC)
 - Configurable 25 kHz or 2 MHz
 - 25 MHz Oscillator
- Power-On Reset
- Five Byte RAM + OTP User Memory
 - RAM Memory Space that is Readable and Writable via I²C
 - User Defined Initial Values Transferred from OTP
- Logic and Mixed-Signal Circuits
- Highly Versatile Macrocells
- Read Back Protection (Read Lock)
- Power Supply
 - 1.8 V (±5 %) to 5.0 V (±10 %) V_{DD}
- Ambient Operating Temperature Range: -40 °C to +85 °C
- RoHS Compliant/Halogen-Free
- Available Package
 - 14-pin STQFN: 2.0 mm x 2.2 mm x 0.55 mm, 0.4 mm pitch

Applications

- Outdoors Electronics
- Factory Automation
- Servers and Networking Equipment
- Chargers

Contents

1. Overview	9
1.1 Block Diagram	9
1.2 User Programmability	10
2. Pin Information	11
2.1 Pin Assignments	11
2.2 Pin Descriptions.....	11
3. Specifications	15
3.1 Absolute Maximum Ratings	15
3.2 ESD Ratings	15
3.3 Recommended Operating Conditions.....	15
3.4 Electrical Specifications	16
3.4.1 Logic IO Specifications	16
3.4.2 I ² C Pins Electrical Specifications	19
3.4.3 Macrocells Current Consumption.....	20
3.4.4 Estimated Typical Delay of Each Macrocell	21
3.4.5 Programmable Delay Typical Delays and Widths	22
3.4.6 Typical Filter Rejection Pulse Width	22
3.4.7 Counter/Delay Specifications.....	23
3.4.8 25 kHz OSC0 Frequency Limits.....	23
3.4.9 25 kHz OSC0 Frequency Error	23
3.4.10 2 MHz OSC0 Frequency Limits	24
3.4.11 2 MHz OSC0 Frequency Error.....	24
3.4.12 25 MHz OSC1 Frequency Limits	25
3.4.13 25 MHz OSC1 Frequency Error	25
3.4.14 OSCs Power-On Delay (Normal Mode)	26
3.4.15 OSCs Power-On Delay (Fast Start-Up Time Mode)	26
3.4.16 ACMP Specifications	26
4. Input/Output Pins	34
4.1 Input Modes	34
4.2 Output Modes	34
4.3 Pull-Up/Down Resistors.....	34
4.4 GPI Structure	34
4.4.1 GPI Structure (for Pin 2)	34
4.5 Matrix OE IO Structure	35
4.5.1 Matrix OE IO Structure (for Pin 5).....	35
4.5.2 Matrix OE IO Structure (for Pin 11).....	36
4.5.3 Matrix OE IO Structure (for Pin 12).....	37
4.5.4 Matrix OE IO Structure (for Pin 14).....	38
4.5.5 Matrix OE 4x Drive Structure (for Pin 8).....	39
4.5.6 Matrix OE 4x Drive Structure (for Pin 10).....	40
4.6 IO Structure	41
4.6.1 IO Structure (for Pins 3, 4, 13)	41
4.6.2 IO Structure (for Pins 6 and 7).....	42
5. Connection Matrix	43
5.1 Matrix Input Table	44
5.2 Matrix Output Table	46
5.3 Connection Matrix Virtual Outputs	49

6.	Combination Function Macrocells	50
6.1	2-Bit LUT or D Flip-Flop Macrocells	50
6.1.1	2-Bit LUT or D Flip-Flop Macrocells Used as 2-Bit LUTs	51
6.1.2	Initial Polarity Operations	53
6.2	3-Bit LUT or D Flip-Flop with Set/Reset Macrocells	53
6.2.1	3-Bit LUT or D Flip-Flop Macrocells Used as 3-Bit LUTs	56
6.2.2	Initial Polarity Operations	58
6.3	3-Bit LUT or Pipe Delay Macrocell	59
6.3.1	3-Bit LUT or Pipe Delay Macrocell Used as 3-Bit LUT	60
6.4	3-Bit LUT or 8-Bit Counter/Delay Macrocells	61
6.4.1	3-Bit LUT or 8-Bit CNT/DLY Block Diagrams	61
6.4.2	3-Bit LUT or Counter/Delay Macrocells Used as 3-Bit LUTs	63
6.5	4-Bit LUT or 16-Bit Counter/Delay Macrocells	65
6.5.1	4-Bit LUT or 16-Bit CNT/DLY Block Diagram	66
6.5.2	4-Bit LUT or 16-Bit Counter/Delay Macrocells Used as 4-Bit LUTs	67
6.6	CNT/DLY/FSM Timing Diagrams	69
6.6.1	Delay Mode (Edge Select: Both, Counter Data: 3) CNT/DLY2 to CNT/DLY6	69
6.6.2	Count Mode (Count Data: 3), Counter Reset (Rising Edge Detect) CNT/DLY2 to CNT/DLY6	69
6.6.3	One-Shot Mode CNT/DLY0 to CNT/DLY6	70
6.6.4	Frequency Detection Mode CNT/DLY0 to CNT/DLY6	70
6.6.5	Edge Detection Mode CNT/DLY2 to CNT/DLY6	71
6.6.6	Delay Mode CNT/DLY0 to CNT/DLY6	71
6.6.7	CNT/FSM Mode CNT/DLY0, CNT/DLY1	72
6.6.8	Difference in Counter Value for Counter, Delay, One-Shot, and Frequency Detect Modes	73
6.7	2-bit LUT or Programmable Pattern Generator	73
6.8	Wake and Sleep Controller	74
7.	Analog Comparators	77
7.1	ACMP0 Block Diagram	78
7.2	ACMP1 Block Diagram	78
7.3	ACMP2 Block Diagram	79
7.4	ACMP Typical Performance	79
8.	Programmable Delay/Edge Detector	83
8.1	Programmable Delay Timing Diagram - Edge Detector Output	83
9.	Additional Logic Function. Deglitch Filter	84
9.1	Deglitch Filter/Edge Detector	84
10.	Voltage Reference	85
10.1	Voltage Reference Overview	85
10.2	V _{REF} Block Diagram	86
10.3	V _{REF} Load Regulation	86
11.	Clocking	88
11.1	OSC General Description	88
11.2	25 kHz/2 MHz and 25 MHz Oscillators	88
11.3	External Clocking	89
11.3.1	Pin 14 Source for 25 kHz/2 MHz Clock	89
11.3.2	Pin 13 Source for 25 MHz Clock	89
11.4	Oscillators Power-On Delay	90
11.5	Oscillators Accuracy	92
11.6	Oscillators Settling Time	94
11.7	Oscillators Current Consumption	95

12. Power-On Reset	100
12.1 General Operation	100
12.2 POR Sequence	101
12.3 Macrocells Output States During POR Sequence	101
12.3.1 Initialization	102
12.3.2 Power-Down	103
13. I²C Serial Communications Macrocell	104
13.1 I ² C Serial Communications Macrocell Overview	104
13.2 I ² C Serial Communications Device Addressing	104
13.3 I ² C Serial General Timing	105
13.4 I ² C IO Expander Output Timing	105
13.5 I ² C Serial Communications Commands	105
13.5.1 Byte Write Command	105
13.5.2 Sequential Write Command	106
13.5.3 Current Address Read Command	106
13.5.4 Random Read Command	106
13.5.5 Sequential Read Command	107
13.5.6 I ² C Serial Command Address Space	107
13.5.7 I ² C Serial Command Register Map	107
13.6 I ² C Serial Command Register Protection	108
13.6.1 Register Read/Write Protection	109
13.6.2 I ² C Serial Reset Command	111
13.7 I ² C Additional Options	112
13.7.1 Reading Counter Data via I ² C	112
13.7.2 User RAM and OTP Memory Array	112
14. Register Definitions	113
14.1 Register Map	113
15. Package Information	144
15.1 Package Outline Drawings	144
15.1.1 Package Outline for STQFN 14L 2.0 mm x 2.2 mm 0.4P COL Package	144
15.2 Package Top Marking	145
15.2.1 STQFN 14L 2.0 mm x 2.2 mm 0.4P COL Package	145
15.3 STQFN Handling	145
15.4 Soldering Information	145
16. Layout Guidelines	146
16.1 STQFN-14L 2.0 mm x 2.2 mm 0.4P Package	146
17. Ordering Information	147
17.1 Tape and Reel Specifications	147
17.2 Carrier Tape Drawing and Dimensions	147
Glossary	148
Revision History	150
A. ECAD Design Information	151
A.1 Part Number Indexing	151
A.2 Symbol Pin Information	151
A.2.1 14-STQFN	151
A.3 Symbol Parameters	152
A.4 Footprint Design Information	153

Figures

Figure 1. Block Diagram	9
Figure 2. Steps to Create a Custom GreenPAK Device	10
Figure 3. Pin Assignments – STQFN-14 (Top View)	11
Figure 4. GPI Structure Diagram (Pin 2).....	34
Figure 5. Matrix OE IO Structure Diagram (Pin 5).....	35
Figure 6. Matrix OE IO Structure Diagram (Pin 11).....	36
Figure 7. Matrix OE IO Structure Diagram (Pin 12).....	37
Figure 8. Matrix OE IO Structure Diagram (Pin 14).....	38
Figure 9. Matrix OE IO 4x Drive Structure Diagram (Pin 8).....	39
Figure 10. Matrix OE IO 4x Drive Structure Diagram (Pin 10).....	40
Figure 11. IO Structure Diagram (Pin 3, 4, 13).....	41
Figure 12. IO Structure Diagram (Pin 6, 7).....	42
Figure 13. Connection Matrix.....	43
Figure 14. Connection Matrix Example.....	43
Figure 15. 2-bit LUT0 or DFF0.....	50
Figure 16. 2-bit LUT1 or DFF1.....	51
Figure 17. 2-bit LUT2 or DFF2.....	51
Figure 18. DFF Polarity Operations	53
Figure 19. 3-bit LUT0 or DFF3 with RST/SET	53
Figure 20. 3-bit LUT1 or DFF4 with RST/SET	54
Figure 21. 3-bit LUT2 or DFF5 with RST/SET	54
Figure 22. 3-bit LUT3 or DFF6 with RST/SET	55
Figure 23. 3-bit LUT4 or DFF7 with RST/SET	55
Figure 24. DFF Polarity Operations with nReset	58
Figure 25. DFF Polarity Operations with nSet	59
Figure 26. 3-bit LUT10 or Pipe Delay	60
Figure 27. 3-bit LUT5 or CNT/DLY2	61
Figure 28. 3-bit LUT6 or CNT/DLY3	61
Figure 29. 3-bit LUT7 or CNT/DLY4	62
Figure 30. 3-bit LUT8 or CNT/DLY5	62
Figure 31. 3-bit LUT9 or CNT/DLY6	63
Figure 32. 4-bit LUT0 or CNT/DLY0	66
Figure 33. 4-bit LUT1 or CNT/DLY1	66
Figure 34. Delay Mode Timing Diagram	69
Figure 35. Counter Mode Timing Diagram	69
Figure 36. One-Shot Function Timing Diagram	70
Figure 37. Frequency Detection Mode Timing Diagram	70
Figure 38. Edge Detection Mode Timing Diagram.....	71
Figure 39. Delay Mode Timing Diagram	71
Figure 40. CNT/FSM Timing Diagram (Reset Rising Edge Mode, Oscillator is Forced On, UP = 0) for Counter Data = 3.....	72
Figure 41. CNT/FSM Timing Diagram (Set Rising Edge Mode, Oscillator is Forced On, UP = 0) for Counter Data = 3.....	72
Figure 42. CNT/FSM Timing Diagram (Reset Rising Edge Mode, Oscillator is Forced On, UP = 1) for Counter Data = 3.....	72
Figure 43. CNT/FSM Timing Diagram (Set Rising Edge Mode, Oscillator is Forced On, UP = 1) for Counter Data = 3.....	73
Figure 44. Counter Value, Counter Data = 3	73
Figure 45. 2-bit LUT3 or PGen	74
Figure 46. PGen Timing Diagram	74
Figure 47. Wake/Sleep Controller.....	75
Figure 48. ACMP0 Block Diagram.....	78

Figure 49. ACMP1 Block Diagram	78
Figure 50. ACMP2 Block Diagram	79
Figure 51. ACMPx Power-On Delay vs. V_{DD} , BG Delay – Any	79
Figure 52. ACMPx Input Offset Voltage vs. V_{REF} at $V_{DD} = 1.71\text{ V to }5.5\text{ V}$, $T_A = -40\text{ }^\circ\text{C to }+85\text{ }^\circ\text{C}$	80
Figure 53. ACMPx Buffer Input Offset Voltage vs. V_{REF} at $V_{DD} = 1.71\text{ V to }5.5\text{ V}$, $T_A = -40\text{ }^\circ\text{C to }+85\text{ }^\circ\text{C}$	80
Figure 54. ACMPx Typical Propagation Delay at $T_A = +25\text{ }^\circ\text{C}$, Gain = 1, Hysteresis = 0, $V_{DD} = 1.71\text{ V to }5.5\text{ V}$, LPF-Enable	81
Figure 55. ACMPx Typical Propagation Delay at $T_A = +25\text{ }^\circ\text{C}$, Gain = 1, Hysteresis = 0, $V_{DD} = 1.71\text{ V to }5.5\text{ V}$, LPF-Disable	81
Figure 56. ACMPx Current Consumption vs. V_{DD} at V_{IN+} Connected to V_{DD} , Internal $V_{REF} = 50\text{ mV}$	82
Figure 57. Buffered ACMPx Current Consumption vs. V_{DD} at V_{IN+} Connected to V_{DD} , Internal $V_{REF} = 50\text{ mV}$	82
Figure 58. Programmable Delay	83
Figure 59. Edge Detector Output	83
Figure 60. Deglitch Filter/Edge Detector	84
Figure 61. Voltage Reference Block Diagram	86
Figure 62. Typical Load Regulation, $V_{REF} = 600\text{ mV}$, $T_A = -40\text{ }^\circ\text{C to }+85\text{ }^\circ\text{C}$, Buffer – Enable	86
Figure 63. Typical Load Regulation, $V_{REF} = 1000\text{ mV}$, $T_A = -40\text{ }^\circ\text{C to }+85\text{ }^\circ\text{C}$, Buffer - Enable	87
Figure 64. Typical Load Regulation, $V_{REF} = 1200\text{ mV}$, $T_A = -40\text{ }^\circ\text{C to }+85\text{ }^\circ\text{C}$, Buffer – Enable	87
Figure 65. 25 kHz/2 MHz OSC0 Block Diagram	89
Figure 66. 25 MHz OSC1 Block Diagram	89
Figure 67. Oscillator Startup Diagram	90
Figure 68. Oscillator Maximum Power-On Delay vs. V_{DD} at $T_A = +25\text{ }^\circ\text{C}$, OSC0 = 25 kHz	90
Figure 69. Oscillator Maximum Power-On Delay vs. V_{DD} at $T_A = +25\text{ }^\circ\text{C}$, OSC0 = 2 MHz	91
Figure 70. Oscillator Maximum Power-On Delay vs. V_{DD} at $T_A = +25\text{ }^\circ\text{C}$, OSC1 = 25 MHz	91
Figure 71. Oscillator Frequency vs. Ambient Temperature, OSC0 = 25 kHz	92
Figure 72. Oscillator Frequency vs. Ambient Temperature, OSC0 = 2 MHz	92
Figure 73. Oscillator Frequency vs. Ambient Temperature, OSC1 = 25 MHz	93
Figure 74. Oscillators Total Error vs. Ambient Temperature	93
Figure 75. Oscillator0 Settling Time, $V_{DD} = 3.3\text{ V}$, $T_A = +25\text{ }^\circ\text{C}$, OSC0 = 25 kHz	94
Figure 76. Oscillator0 Settling Time, $V_{DD} = 3.3\text{ V}$, $T_A = +25\text{ }^\circ\text{C}$, OSC0 = 2 MHz	94
Figure 77. Oscillator0 Settling Time, $V_{DD} = 3.3\text{ V}$, $T_A = +25\text{ }^\circ\text{C}$, OSC1 = 25 MHz	95
Figure 78. OSC0 (25 kHz) Current Consumption vs. V_{DD} , All Pre-Dividers	95
Figure 79. OSC0 (2 MHz) Current Consumption vs. V_{DD} , Pre-Divider = 1	96
Figure 80. OSC0 (2 MHz) Current Consumption vs. V_{DD} , Pre-Divider = 2	96
Figure 81. OSC0 (2 MHz) Current Consumption vs. V_{DD} , Pre-Divider = 4	97
Figure 82. OSC0 (2 MHz) Current Consumption vs. V_{DD} , Pre-Divider = 8	97
Figure 83. OSC1 (25 MHz) Current Consumption vs. V_{DD} , Pre-Divider = 1	98
Figure 84. OSC1 (25 MHz) Current Consumption vs. V_{DD} , Pre-Divider = 2	98
Figure 85. OSC1 (25 MHz) Current Consumption vs. V_{DD} , Pre-Divider = 4	99
Figure 86. OSC1 (25 MHz) Current Consumption vs. V_{DD} , Pre-Divider = 8	99
Figure 87. POR Sequence	101
Figure 88. Internal Macrocell States during POR Sequence	102
Figure 89. Power-Down	103
Figure 90. Basic Command Structure	105
Figure 91. I ² C General Timing Characteristics	105
Figure 92. I ² C IO Expander Output Timing	105
Figure 93. Byte Write Command, R/W = 0	106
Figure 94. Sequential Write Command, R/W = 0	106
Figure 95. Current Address Read Command, R/W = 1	106
Figure 96. Random Read Command	107

Figure 97. Sequential Read Command	107
Figure 98. Register Bank Map	108
Figure 99. Serial Reset Command Timing.....	111
Figure 100. STQFN-14 Package Outline Drawing.....	144
Figure 101. STQFN-14 Package Top Marking	145
Figure 102. STQFN-14 Layout Example Schematic.....	146

Tables

Table 1. Pin Descriptions	11
Table 2. Pin Type Definitions	12
Table 3. Functional Pin Description	12
Table 4. Matrix Input Table	44
Table 5. Matrix Output Table	46
Table 6. 2-bit LUT0 Truth Table	51
Table 7. 2-bit LUT1 Truth Table	52
Table 8. 2-bit LUT2 Truth Table	52
Table 9. 2-bit LUT Standard Digital Functions	52
Table 10. 3-bit LUT0 Truth Table	56
Table 11. 3-bit LUT1 Truth Table	56
Table 12. 3-bit LUT2 Truth Table	56
Table 13. 3-bit LUT3 Truth Table	57
Table 14. 3-bit LUT4 Truth Table	57
Table 15. 3-bit LUT Standard Digital Functions	57
Table 16. 3-bit LUT10 Truth Table	60
Table 17. 3-bit LUT5 Truth Table	63
Table 18. 3-bit LUT6 Truth Table	63
Table 19. 3-bit LUT7 Truth Table	64
Table 20. 3-bit LUT8 Truth Table	64
Table 21. 3-bit LUT9 Truth Table	64
Table 22. 3-bit LUT Standard Digital Functions	65
Table 23. 4-bit LUT0 Truth Table	67
Table 24. 4-bit LUT1 Truth Table	68
Table 25. 4-bit LUT Standard Digital Functions	68
Table 26. V _{REF} Selection Table	85
Table 27. Practical V _{REF} Range of Voltage Reference Macrocell	86
Table 28. IO Expander Registers	108
Table 29. Read/Write Protection Options	109
Table 30. RAM Array Table	112
Table 31. Register Map	113

1. Overview

1.1 Block Diagram

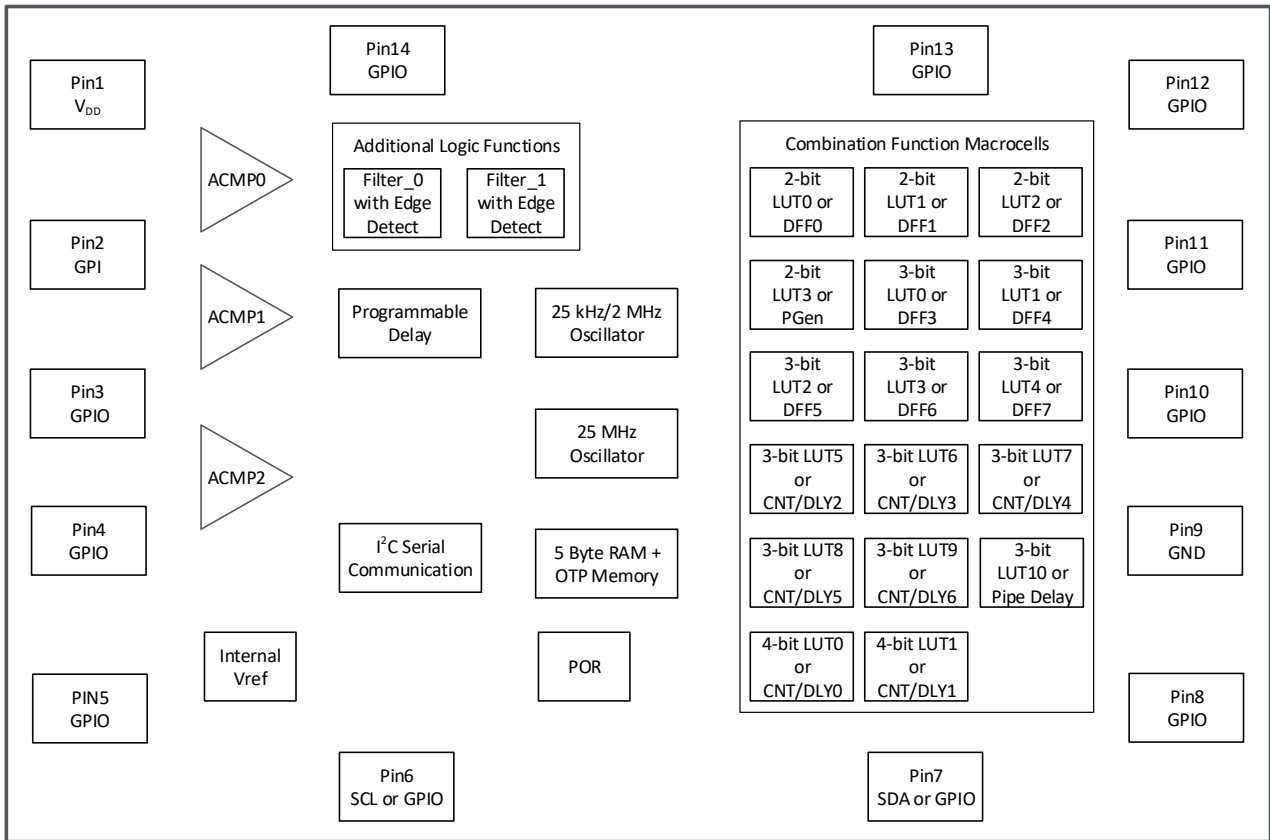

Figure 1. Block Diagram

1.2 User Programmability

Non-volatile memory (NVM) is used to configure the SLG46540's connection matrix routing and macrocells. The NVM is One-Time Programmable (OTP). However, Renesas's GreenPAK development tools can be used to configure the connection matrix and macrocells, without programming the NVM, to allow on-chip emulation. This configuration will remain active on the device as long as it remains powered and can be re-written as needed to facilitate rapid design changes.

When a design is ready for in-circuit testing, the same GreenPAK development tools can be used to program the NVM and create samples for small quantity builds. Once the NVM is programmed, the device will retain this configuration for the duration of its lifetime.

Once the design is finalized, the design file can be forwarded to Renesas to integrate into the production process.

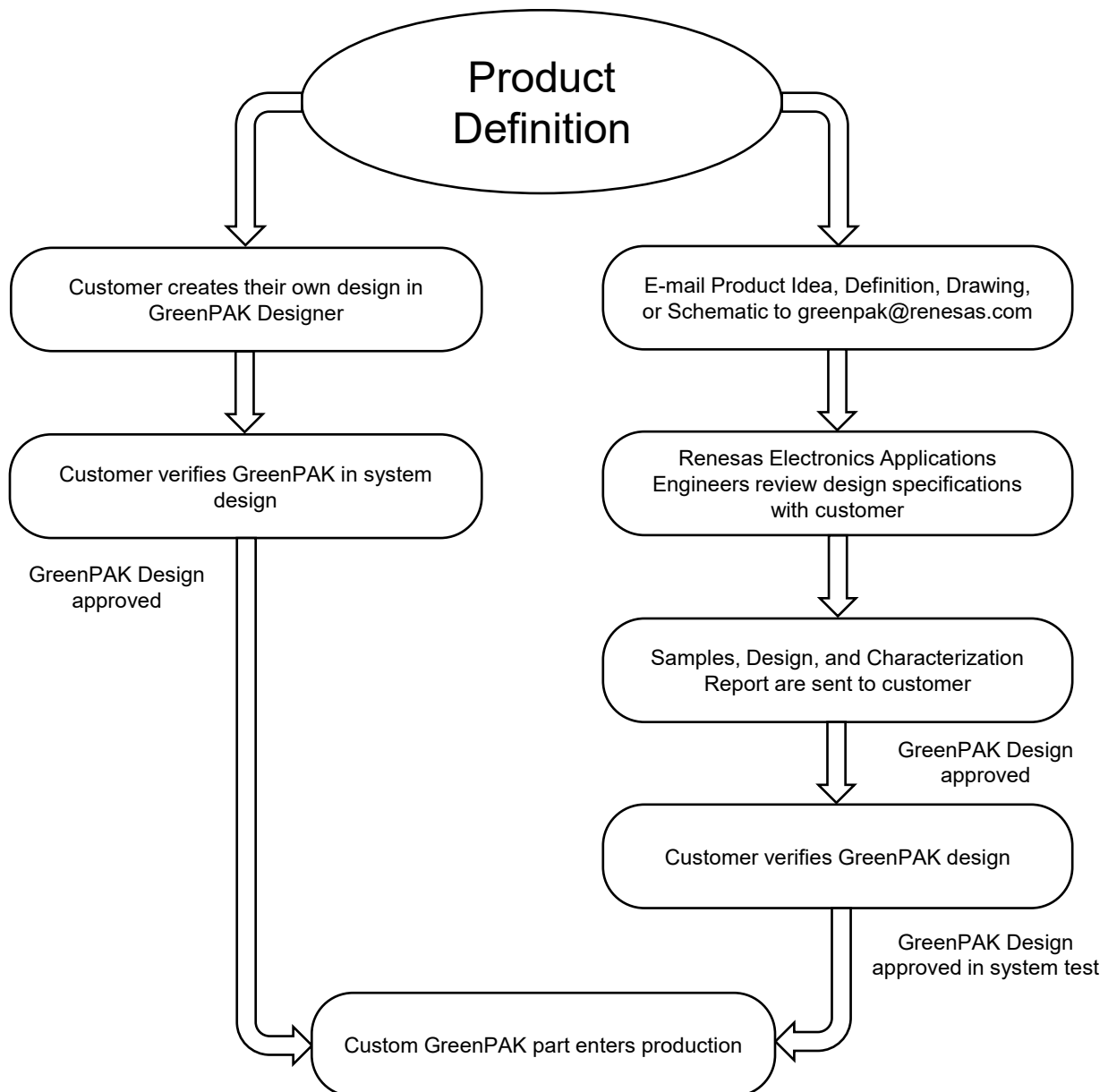

Figure 2. Steps to Create a Custom GreenPAK Device

2. Pin Information

2.1 Pin Assignments

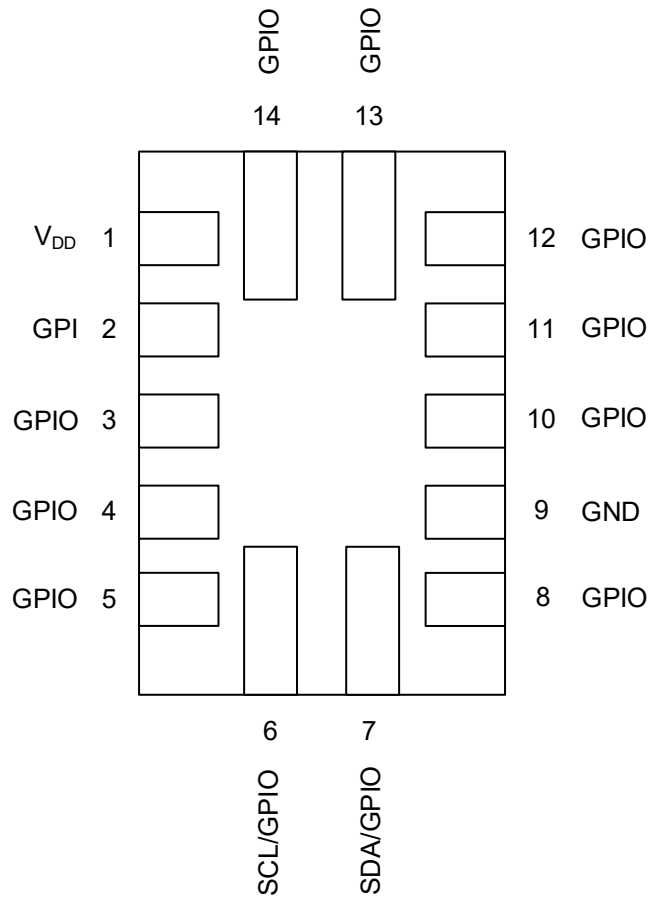

Figure 3. Pin Assignments – STQFN-14 (Top View)

2.2 Pin Descriptions

Table 1. Pin Descriptions

Pin Number	Pin Name	Description
1	V _{DD}	Power Supply
2	GPI	General Purpose Input
3	GPIO	General Purpose IO
4	GPIO	General Purpose IO or ACMP0 (+)
5	GPIO	General Purpose IO with OE or External V _{REF} (ACMP0 IN-)
6	SCL/GPIO	General Purpose IO SCL or GPIOD (NMOS open drain only)
7	SDA/GPIO	General Purpose IO SDA or GPIOD (NMOS open drain only)
8	GPIO	General Purpose invertible IO with OE
9	GND	Ground

Pin Number	Pin Name	Description
10	GPIO	General Purpose invertible IO
11	GPIO	General Purpose invertible IO with OE
12	GPIO	General Purpose invertible IO with OE
13	GPIO	General Purpose IO
14	GPIO	General Purpose IO with OE or External Clock Input

Table 2. Pin Type Definitions

Pin Type	Definition
VDD	Power Supply
IO	Input/Output
GND	General Ground

Table 3. Functional Pin Description

STQFN 14L Pin #	Pin Name	Signal Name	Function	Input Options	Output Options
1	V _{DD}	V _{DD}	Power Supply	-	-
2	GPI	GPI	General Purpose Input	Digital Input without Schmitt Trigger	-
				Digital Input with Schmitt Trigger	-
				Low Voltage Digital Input	-
3	GPIO	GPIO	General Purpose IO	Digital Input without Schmitt Trigger	Push-Pull (1x) (2x)
				Digital Input with Schmitt Trigger	Open-Drain NMOS (1x) (2x)
				Low Voltage Digital Input	Open-Drain PMOS (1x) (2x)
4	GPIO	GPIO	General Purpose IO	Digital Input without Schmitt Trigger	Push-Pull (1x) (2x)
				Digital Input with Schmitt Trigger	Open-Drain NMOS (1x) (2x)
				Low Voltage Digital Input	Open-Drain PMOS (1x) (2x)
	ACMP0+	Analog Comparator 0 Positive Input	Analog	-	

STQFN 14L Pin #	Pin Name	Signal Name	Function	Input Options	Output Options
5	GPIO	GPIO	General Purpose IO with OE ^[1]	Digital Input without Schmitt Trigger	Push-Pull (1x) (2x)
				Digital Input with Schmitt Trigger	Open-Drain NMOS (1x) (2x)
				Low Voltage Digital Input	-
		EXT_V _{REF}	Analog Comparator 0 Negative Input	Analog	-
6	SCL/GPIO	SCL	I ² C Serial Clock	Digital Input without Schmitt Trigger	-
				Digital Input with Schmitt Trigger	-
				Low Voltage Digital Input	-
		GPIO	General Purpose IO	Digital Input without Schmitt Trigger	Open-Drain NMOS (1x) (2x)
				Digital Input with Schmitt Trigger	-
				Low Voltage Digital Input	-
7	SDA/GPIO	SDA	I ² C Serial Data	Digital Input without Schmitt Trigger	-
				Digital Input with Schmitt Trigger	-
				Low Voltage Digital Input	-
		GPIO	General Purpose IO	Digital Input without Schmitt Trigger	Open-Drain NMOS (1x) (2x)
				Digital Input with Schmitt Trigger	-
				Low Voltage Digital Input	-
8	GPIO	GPIO	General Purpose IO with OE ^[1]	Digital Input with Schmitt Trigger	Push-Pull (1x) (2x) Open-Drain NMOS (1x) (2x) -
9	GND	GND	Ground	-	-
10	GPIO	GPIO	General Purpose IO with OE	Digital Input with Schmitt Trigger	Push-Pull (1x) (2x) Open-Drain NMOS (1x) (2x)
11	GPIO	GPIO	General Purpose IO with OE ^[1]	Digital Input with Schmitt Trigger	Push-Pull (1x) (2x) Open-Drain NMOS (1x) (2x)

STQFN 14L Pin #	Pin Name	Signal Name	Function	Input Options	Output Options
12	GPIO	GPIO	General Purpose IO with OE ^[1]	Digital Input with Schmitt Trigger	Push-Pull (1x) (2x)
					Open-Drain NMOS (1x) (2x)
13	GPIO	GPIO	General Purpose IO	Digital Input without Schmitt Trigger	Push-Pull (1x) (2x)
				Digital Input with Schmitt Trigger	Open-Drain NMOS (1x) (2x)
				Low Voltage Digital Input	Open-Drain PMOS (1x) (2x)
14	GPIO	GPIO	General Purpose IO with OE	Digital Input without Schmitt Trigger	Push-Pull (1x) (2x)
				Digital Input with Schmitt Trigger	Open-Drain NMOS (1x) (2x)
				Low Voltage Digital Input	-

- General Purpose IO's with OE can be used to implement bidirectional signals under user control via Connection Matrix to OE signal in IO structure.

3. Specifications

3.1 Absolute Maximum Ratings

Stresses beyond those listed under Absolute Maximum Ratings may cause permanent damage to the device. These are stress ratings only, so functional operation of the device at these or any other conditions beyond those indicated in the operational sections of the specification are not implied. Exposure to Absolute Maximum Rating conditions for extended periods may affect device reliability.

Parameter		Min	Max	Unit
Supply voltage on V_{DD} relative to GND		-0.5	7.0	V
Pin Voltage to GND		GND - 0.5	5.5	V
DC Input Voltage	Pins 2, 6, 7	GND - 0.5	up to 7.0	V
	Pins 3, 4, 5, 8, 10, 11, 12, 13, 14		$V_{DD} + 0.5$, up to 7.0	
V_{DD} DC Current	$T_J = +85\text{ }^\circ\text{C}$	-	45	mA
	$T_J = +105\text{ }^\circ\text{C}$	-	22	mA
GND DC Current	$T_J = +85\text{ }^\circ\text{C}$	-	86	mA
	$T_J = +105\text{ }^\circ\text{C}$	-	41	mA
GPIO DC Current (Through pin)	Push-Pull 1x	-	11	mA
	Push-Pull 2x	-	16	
	OD 1x	-	11	
	OD 2x	-	21	
	OD 4x	-	43	
Current at Input Pin		-1.0	1.0	mA
Storage Temperature Range		-65	+150	$^\circ\text{C}$
Junction Temperature		-	+150	$^\circ\text{C}$
Moisture Sensitivity Level		1		

3.2 ESD Ratings

Parameter	Value	Unit
ESD Protection (Human Body Model)	2000	V
ESD Protection (Charged Device Model)	1300	V

3.3 Recommended Operating Conditions

Parameter	Conditions	Min	Max	Unit
Supply Voltage) (V_{DD})	-	1.71	5.5	V
Operating Temperature	-	-40	+85	$^\circ\text{C}$
Maximal Voltage Applied to any PIN in High Impedance State	-	-	V_{DD}	V
Capacitor Value at V_{DD}	-	0.1	-	μF

Parameter	Conditions	Min	Max	Unit
Analog Input Common Mode Range	Allowable Input Voltage at Analog Pins	-1.2	V_{DD}	V

3.4 Electrical Specifications

3.4.1 Logic IO Specifications

$T_A = -40\text{ }^\circ\text{C}$ to $+85\text{ }^\circ\text{C}$, $V_{DD} = 1.71\text{ V}$ to 5.5 V , unless otherwise noted.

Parameter	Symbol	Conditions	Min	Typ	Max	Unit
ACMP Input Voltage Range	V_{ACMP}	Positive Input	0	-	V_{DD}	V
		Negative Input	0	-	1.2	V
HIGH-Level Input Voltage	V_{IH}	Logic Input ^[1]	$0.7 \times V_{DD}$	-	$V_{DD} + 0.3$	V
		Logic Input with Schmitt Trigger	$0.8 \times V_{DD}$	-	$V_{DD} + 0.3$	V
		Low-Level Logic Input ^[1]	1.25	-	$V_{DD} + 0.3$	V
LOW-Level Input Voltage	V_{IL}	Logic Input ^[1]	$GND - 0.3$	-	$0.3 \times V_{DD}$	V
		Logic Input with Schmitt Trigger	$GND - 0.3$	-	$0.2 \times V_{DD}$	V
		Low-Level Logic Input ^[1]	$GND - 0.3$	-	0.5	V
Schmitt Trigger Hysteresis Voltage	V_{HYS}	Logic Input with Schmitt Trigger, $V_{DD} = 1.8\text{ V} \pm 5\%$	$0.19 \times V_{DD}$	$0.25 \times V_{DD}$	$0.32 \times V_{DD}$	V
		Logic Input with Schmitt Trigger, $V_{DD} = 3.3\text{ V} \pm 10\%$	$0.16 \times V_{DD}$	$0.20 \times V_{DD}$	$0.26 \times V_{DD}$	V
		Logic Input with Schmitt Trigger, $V_{DD} = 5.0\text{ V} \pm 10\%$	$0.15 \times V_{DD}$	$0.18 \times V_{DD}$	$0.23 \times V_{DD}$	V
Input leakage (Absolute Value)	I_{LKG}	-	-	-	1000	nA
HIGH-Level Output Voltage	V_{OH}	Push-Pull, $I_{OH} = 100\text{ }\mu\text{A}$, 1x Drive, $V_{DD} = 1.8\text{ V} \pm 5\%$	$0.94 \times V_{DD}$	$0.99 \times V_{DD}$	-	V
		Push-Pull, $I_{OH} = 3\text{ mA}$, 1x Drive, $V_{DD} = 3.3\text{ V} \pm 10\%$	$0.81 \times V_{DD}$	$0.93 \times V_{DD}$	-	V
		Push-Pull, $I_{OH} = 5\text{ mA}$, 1x Drive, $V_{DD} = 5.0\text{ V} \pm 10\%$	$0.83 \times V_{DD}$	$0.95 \times V_{DD}$	-	V
		PMOS OD, $I_{OH} = 100\text{ }\mu\text{A}$, 1x Drive, $V_{DD} = 1.8\text{ V} \pm 5\%$	$0.94 \times V_{DD}$	$0.99 \times V_{DD}$	-	V
		PMOS OD, $I_{OH} = 3\text{ mA}$, 1x Drive, $V_{DD} = 3.3\text{ V} \pm 10\%$	$0.81 \times V_{DD}$	$0.93 \times V_{DD}$	-	V
		PMOS OD, $I_{OH} = 5\text{ mA}$, 1x Drive, $V_{DD} = 5.0\text{ V} \pm 10\%$	$0.83 \times V_{DD}$	$0.95 \times V_{DD}$	-	V
		Push-Pull, $I_{OH} = 100\text{ }\mu\text{A}$, 2x Drive, $V_{DD} = 1.8\text{ V} \pm 5\%$	$0.95 \times V_{DD}$	$1 \times V_{DD}$	-	V
		Push-Pull, $I_{OH} = 3\text{ mA}$, 2x Drive, $V_{DD} = 3.3\text{ V} \pm 10\%$	$0.86 \times V_{DD}$	$0.97 \times V_{DD}$	-	V
		Push-Pull, $I_{OH} = 5\text{ mA}$, 2x Drive, $V_{DD} = 5.0\text{ V} \pm 10\%$	$0.86 \times V_{DD}$	$0.97 \times V_{DD}$	-	V

Parameter	Symbol	Conditions	Min	Typ	Max	Unit
HIGH-Level Output Voltage	V _{OH}	PMOS OD, I _{OH} = 100 μA, 2x Drive, V _{DD} = 1.8 V ± 5 %	0.95 x V _{DD}	1 x V _{DD}	-	V
		PMOS OD, I _{OH} = 3 mA, 2x Drive, V _{DD} = 3.3 V ± 10 %	0.86 x V _{DD}	0.97 x V _{DD}	-	V
		PMOS OD, I _{OH} = 5 mA, 2x Drive, V _{DD} = 5.0 V ± 10 %	0.86 x V _{DD}	0.97 x V _{DD}	-	V
LOW-Level Output Voltage	V _{OL}	Push-Pull, I _{OL} = 100 μA, 1x Drive, V _{DD} = 1.8 V ± 5 %	-	0.004 x V _{DD}	0.006 x V _{DD}	V
		Push-Pull, I _{OL} = 3 mA, 1x Drive, V _{DD} = 3.3 V ± 10 %	-	0.041 x V _{DD}	0.063 x V _{DD}	V
		Push-Pull, I _{OL} = 5 mA, 1x Drive, V _{DD} = 5.0 V ± 10 %	-	0.035 x V _{DD}	0.053 x V _{DD}	V
		Push-Pull, I _{OL} = 100 μA, 2x Drive, V _{DD} = 1.8 V ± 5 %	-	0.002 x V _{DD}	0.003 x V _{DD}	V
		Push-Pull, I _{OL} = 3 mA, 2x Drive, V _{DD} = 3.3 V ± 10 %	-	0.02 x V _{DD}	0.035 x V _{DD}	V
		Push-Pull, I _{OL} = 5 mA, 2x Drive, V _{DD} = 5.0 V ± 10 %	-	0.018 x V _{DD}	0.03 x V _{DD}	V
		NMOS Open-Drain, I _{OL} = 100 μA, 1x Drive, V _{DD} = 1.8 V ± 5 %	-	0.003 x V _{DD}	0.004 x V _{DD}	V
		NMOS Open-Drain, I _{OL} = 3 mA, 1x Drive, V _{DD} = 3.3 V ± 10 %	-	0.026 x V _{DD}	0.041 x V _{DD}	V
		NMOS Open-Drain, I _{OL} = 5 mA, 1x Drive, V _{DD} = 5.0 V ± 10 %	-	0.023 x V _{DD}	0.035 x V _{DD}	V
		NMOS Open-Drain, I _{OL} = 100 μA, 2x Drive, V _{DD} = 1.8 V ± 5 %	-	0.002 x V _{DD}	0.002 x V _{DD}	V
		NMOS Open-Drain, I _{OL} = 3 mA, 2x Drive, V _{DD} = 3.3 V ± 10 %	-	0.014 x V _{DD}	0.021 x V _{DD}	V
		NMOS Open-Drain, I _{OL} = 5 mA, 2x Drive, V _{DD} = 5.0 V ± 10 %	-	0.012 x V _{DD}	0.018 x V _{DD}	V
		Open-Drain NMOS 4x, PINs 8, 10, I _{OL} = 100 μA, V _{DD} = 1.8 V ± 5 %	-	0.001 x V _{DD}	0.001 x V _{DD}	V
		Open-Drain NMOS 4x, PINs 8, 10, I _{OL} = 3 mA, V _{DD} = 3.3 V ± 10 %	-	0.007 x V _{DD}	0.011 x V _{DD}	V
		Open-Drain NMOS 4x, PINs 8, 10, I _{OL} = 5 mA, V _{DD} = 5.0 V ± 10 %	-	0.006 x V _{DD}	0.009 x V _{DD}	V
HIGH-Level Output Pulse Current ^[2]	I _{OH}	Push-Pull, V _{OH} = V _{DD} - 0.2, 1x Drive, V _{DD} = 1.8 V ± 5 %	0.94	1.47	-	mA
		Push-Pull, V _{OH} = 2.4 V, 1x Drive, V _{DD} = 3.3 V ± 10 %	5.24	13.11	-	mA
		Push-Pull, V _{OH} = 2.4 V, 1x Drive, V _{DD} = 5.0 V ± 10 %	19.43	34.30	-	mA

Parameter	Symbol	Conditions	Min	Typ	Max	Unit
HIGH-Level Output Pulse Current [2]	I _{OH}	PMOS OD, V _{OH} = V _{DD} - 0.2, 1x Drive, V _{DD} = 1.8 V ± 5 %	0.96	1.47	-	mA
		PMOS OD, V _{OH} = 2.4 V, 1x Drive, V _{DD} = 3.3 V ± 10 %	5.35	13.13	-	mA
		PMOS OD, V _{OH} = 2.4 V, 1x Drive, V _{DD} = 5.0 V ± 10 %	19.71	34.35	-	mA
		Push-Pull, V _{OH} = V _{DD} - 0.2, 2x Drive, V _{DD} = 1.8 V ± 5 %	1.86	2.91	-	mA
		Push-Pull, V _{OH} = 2.4 V, 2x Drive, V _{DD} = 3.3 V ± 10 %	10.42	25.89	-	mA
		Push-Pull, V _{OH} = 2.4 V, 2X Drive, V _{DD} = 5.0 V ± 10 %	38.38	67.39	-	mA
		PMOS OD, V _{OH} = V _{DD} - 0.2, 2x Drive, V _{DD} = 1.8 V ± 5 %	1.89	2.91	-	mA
		PMOS OD, V _{OH} = 2.4 V, 2x Drive, V _{DD} = 3.3 V ± 10 %	10.56	25.93	-	mA
		PMOS OD, V _{OH} = 2.4 V, 2x Drive, V _{DD} = 5.0 V ± 10 %	38.70	67.49	-	mA
LOW-Level Output Pulse Current [2]	I _{OL}	Push-Pull, V _{OL} = 0.15 V, 1x Drive, V _{DD} = 1.8 V ± 5 %	0.92	1.67	-	mA
		Push-Pull, V _{OL} = 0.4 V, 1x Drive, V _{DD} = 3.3 V ± 10 %	4.76	8.47	-	mA
		Push-Pull, V _{OL} = 0.4 V, 1x Drive, V _{DD} = 5.0 V ± 10 %	6.28	11.20	-	mA
		Push-Pull, V _{OL} = 0.15 V, 2x Drive, V _{DD} = 1.8 V ± 5 %	1.83	3.33	-	mA
		Push-Pull, V _{OL} = 0.4 V, 2x Drive, V _{DD} = 3.3 V ± 10 %	9.52	16.77	-	mA
		Push-Pull, V _{OL} = 0.4 V, 2x Drive, V _{DD} = 5.0 V ± 10 %	12.50	22.04	-	mA
		NMOS Open-Drain, V _{OL} = 0.15 V, 1x Drive, V _{DD} = 1.8 V ± 5 %	1.38	2.53	-	mA
		NMOS Open-Drain, V _{OL} = 0.4 V, 1x Drive, V _{DD} = 3.3 V ± 10 %	7.31	12.82	-	mA
		NMOS Open-Drain, V _{OL} = 0.4 V, 1x Drive, V _{DD} = 5.0 V ± 10 %	9.72	16.92	-	mA
		NMOS Open-Drain, V _{OL} = 0.15 V, 2x Drive, V _{DD} = 1.8 V ± 5 %	2.75	4.96	-	mA
		NMOS Open-Drain, V _{OL} = 0.4 V, 2x Drive, V _{DD} = 3.3 V ± 10 %	14.37	24.83	-	mA
NMOS Open-Drain, V _{OL} = 0.4 V, 2x Drive, V _{DD} = 5.0 V ± 10 %	17.34	32.50	-	mA		

Parameter	Symbol	Conditions	Min	Typ	Max	Unit
LOW-Level Output Pulse Current ^[2]	I _{OL}	Open-Drain NMOS 4x, PINs 8, 10, V _{OL} = 0.15 V, V _{DD} = 1.8 V ± 5 %	6.88	9.84	-	mA
		Open-Drain NMOS 4x, PINs 8, 10, V _{OL} = 0.4 V, V _{DD} = 3.3 V ± 10 %	28.45	48.87	-	mA
		Open-Drain NMOS 4x, PINs 8, 10, V _{OL} = 0.4 V, V _{DD} = 5.0 V ± 10 %	36.83	63.54	-	mA
Startup Time	T _{SU}	From V _{DD} rising past PON _{THR}	0.86	1.30	1.91	ms
Power-On Threshold	PON _{THR}	V _{DD} Level Required to Start Up the Chip	1.36	1.55	1.68	V
Power-Off Threshold	POFF _{THR}	V _{DD} Level Required to Switch Off the Chip	0.89	1.18	1.42	V
Pull-up or Pull-down Resistance	R _{PULL}	1 MΩ Pull-up: V _{IN} = GND, 1 MΩ Pull-down: V _{IN} = V _{DD}	-	1145	-	kΩ
		100 kΩ Pull-up: V _{IN} = GND, 100 kΩ Pull-down: V _{IN} = V _{DD}	-	114	-	kΩ
		10 kΩ Pull-up: V _{IN} = GND, 10 kΩ Pull-down: V _{IN} = V _{DD}	-	12	-	kΩ
Input Capacitance	C _{IN}	-	-	1.86	-	pF

1. No hysteresis.
2. DC or average current through any pin should not exceed value given in Absolute Maximum Conditions.

3.4.2 I²C Pins Electrical Specifications

T_A = -40 °C to +85 °C, V_{DD} = 1.71 V to 5.5 V, unless otherwise noted.

Parameter	Symbol	Conditions	Fast Mode		Unit
			Min	Max	
IO Stage					
LOW-level Input Voltage	V _{IL}		-0.5	0.3 x V _{DD}	V
HIGH-level Input Voltage	V _{IH}		0.7 x V _{DD}	V _{DD} + 0.5	V
Hysteresis of Schmitt Trigger Inputs	V _{HYS}		0.05 x V _{DD}	-	V
LOW-Level Output Voltage 1	V _{OL1}	(Open-Drain) at 3 mA sink current, V _{DD} > 2 V	0	0.4	V
LOW-Level Output Voltage 2	V _{OL2}	(Open-Drain) at 2 mA sink current, V _{DD} ≤ 2 V	0	0.2 x V _{DD}	V
LOW-Level Output Current	I _{OL}	V _{OL} = 0.4 V	3	-	mA
		V _{OL} = 0.6 V	6	-	mA
Output Fall Time from V _{IHmin} to V _{ILmax} ^[1]	t _{of}		20 x (V _{DD} /5.5)	250	ns
Pulse Width of Spikes that must be suppressed by the Input Filter	t _{SP}	SDA line	0	50	ns
		SCL line	0	11 ^[1]	ns
Input Current Each IO Pin	I _i	0.1 x V _{DD} < V _I < 0.9 x V _{DDmax}	-10	+10	μA

Parameter	Symbol	Conditions	Fast Mode		Unit
			Min	Max	
Capacitance for Each IO Pin	C_i		-	10	pF
Timing (see Figure 91 for Diagram)					
Clock Frequency, SCL	F_{SCL}		-	400	kHz
Clock Pulse Width Low	t_{LOW}		1300	-	ns
Clock Pulse Width High	t_{HIGH}		600	-	ns
Data Valid Acknowledge Time	t_{VD_ACK}		-	900	ns
Data Valid Time	t_{VD_DAT}		-	900	ns
Bus Free Time between Stop and Start	t_{BUF}		1300	-	ns
Start Hold Time	t_{HD_STA}		600	-	ns
Start Set-up Time	t_{SU_STA}		600	-	ns
Data Hold Time	t_{HD_DAT}		0	-	ns
Data Set-up Time	t_{SU_DAT}		100	-	ns
Inputs Rise Time	t_R		-	300	ns
Inputs Fall Time	t_F		-	300	ns
Stop Set-up Time	t_{SU_STO}		600	-	ns
Data Out Hold Time	t_{DH}		50	-	ns
Output Data Valid (IO Expander)	t_{pv}	0.7 x V_{DD} of SCL to 50 % P[0...4] Output Rise	-	275	ns

1. Does not meet standard I²C specifications: $t_{of} = 20x (V_{DD}/5.5 V)$ (min), $t_{SP} = 50 ns$ (max).

3.4.3 Macrocells Current Consumption

Typical values are at $T_A = +25\text{ }^\circ\text{C}$, unless otherwise specified.

Parameter	Symbol	Note	$V_{DD} = 1.8 V$	$V_{DD} = 3.3 V$	$V_{DD} = 5.0 V$	Unit
Current	I_{DD}	Chip Quiescent, I_{DD}	0.27	0.52	0.80	μA
		OSC 2 MHz, pre-divide = 1	32.79	51.01	77.30	
		OSC 2 MHz, pre-divide = 8	19.27	24.77	34.57	
		OSC 25 kHz, pre-divide = 1	5.39	6.09	7.33	
		OSC 25 kHz, pre-divide = 8	5.22	5.76	6.80	
		OSC 25 MHz, pre-divide = 1	78.86	208.03	379.46	
		OSC 25 MHz, pre-divide = 8	69.90	184.78	345.11	
		ACMP (each)	47.61	44.22	52.50	
		ACMP with buffer (each)	63.84	60.91	69.80	

3.4.4 Estimated Typical Delay of Each Macrocell

Typical values are at $T_A = +25\text{ }^\circ\text{C}$, unless otherwise specified.

Parameter	Symbol	Note	$V_{DD} = 1.8\text{ V}$		$V_{DD} = 3.3\text{ V}$		$V_{DD} = 5.0\text{ V}$		Unit
			Rising	Falling	Rising	Falling	Rising	Falling	
GPI and GPIO Macrocell									
Propagation Delay	t_{PD}	Digital Input to PP 1x	44	47	20	21	15	15	ns
		Digital Input with Schmitt Trigger to PP 1x	45	47	20	20	14	15	
		Low Voltage Digital input to PP 1x	50	482	23	191	18	123	
		Digital input to PMOS output	43	-	19	-	14	-	
		Digital input to NMOS output	-	82	-	30	-	20	
		Output enable from pin, OE Hi-Z to 1	47	-	20	-	15	-	
		Output enable from pin, OE Hi-Z to 0	44	-	19	-	14	-	
Pulse Width	t_w	IO with 1x Push-Pull (min transmitted)	20	20	20	20	20	20	ns
Combination Function Macrocell									
Propagation Delay	t_{PD}	2-bit LUT (LATCH)	35	34	14	14	10	10	ns
		LATCH (2-bit LUT)	30	33	12	13	9	9	
		3-bit LUT(LATCH)	31	34	13	13	10	9	
		LATCH+nRESET(3-bit LUT)	37	36	16	15	11	11	
		4-bit LUT	30	35	13	14	9	9	
		2-bit LUT	30	33	13	13	9	9	
		3-bit LUT	31	34	13	13	10	9	
		CNT/DLY Logic	61	61	25	25	18	17	
Programmable Delay									
Propagation Delay	t_{PD}	P_DLY1C	377	370	168	164	124	121	ns
		P_DLY2C	690	682	309	306	229	226	
		P_DLY3C	1002	995	450	447	334	332	
		P_DLY4C	1312	1304	590	587	438	436	
Pipe Delay									
Propagation Delay	t_{PD}	Pipe Delay OUT0	48	43	20	18	15	13	ns
		Pipe Delay OUT1	45	39	19	17	14	12	

Parameter	Symbol	Note	V _{DD} = 1.8 V		V _{DD} = 3.3 V		V _{DD} = 5.0 V		Unit
			Rising	Falling	Rising	Falling	Rising	Falling	
Filter/Edge Detector									
Propagation Delay	t _{PD}	Filter 0	225	205	86	80	56	53	ns
		Filter 1	175	156	66	61	43	40	
		Mode: Edge Detect 0, Any Edge Detect	60	64	23	24	16	17	
		Mode: Edge Detect 1, Any Edge Detect	59	62	23	24	16	16	
		Mode: Edge Detect 0, Both Edge Detect	378	366	167	163	123	120	
		Mode: Edge Detect 1, Both Edge Detect	378	364	166	162	123	119	
ACMP									
Propagation Delay	t _{PD}	ACMP (10 mV overdrive, Low Bandwidth – Disable, IN- = 600 mV)	1461	1486	1346	1408	1326	1400	ns

3.4.5 Programmable Delay Typical Delays and Widths

Typical values are at T_A = +25 °C, unless otherwise specified.

Parameter	Symbol	Note	Configuration	V _{DD} = 1.8 V	V _{DD} = 3.3 V	V _{DD} = 5.0 V	Unit
Pulse Width	t _w	Mode: (any) Edge Detect, Edge Detect Output	1-Cell	310	140	104	ns
			2-Cell	622	281	209	
			3-Cell	935	422	314	
			4-Cell	1244	562	419	
Delay Time	t _{DLY1}	Mode: (any) Edge Detect, Edge Detect Output	1-Cell	55	22	16	ns
			2-Cell	55	22	16	
			3-Cell	55	22	16	
			4-Cell	55	22	16	
	t _{DLY2}	Mode: Both Edge Delay, Edge Detect Output	1-Cell	373	165	122	ns
			2-Cell	685	307	227	
			3-Cell	998	448	332	
			4-Cell	1307	588	437	

3.4.6 Typical Filter Rejection Pulse Width

Typical values are at T_A = +25 °C, unless otherwise specified.

Parameter	V _{DD} = 1.8 V	V _{DD} = 3.3 V	V _{DD} = 5.0 V	Unit
Filtered Pulse Width for Filter 0	< 143	< 57	< 36	ns
Filtered Pulse Width for Filter 1	< 97	< 39	< 25	ns

3.4.7 Counter/Delay Specifications

Typical values are at $T_A = +25\text{ }^\circ\text{C}$, unless otherwise specified.

Parameter	OSC Freq	OSC Power	$V_{DD} = 1.8\text{ V}$	$V_{DD} = 3.3\text{ V}$	$V_{DD} = 5.0\text{ V}$	Unit
Power-On Delay Time	25 kHz	Auto	1.6	1.6	1.6	μs
Power-On Delay Time (Fast Start)	25 kHz	Auto	2.1	2.1	2.1	μs
Power-On Delay	2 MHz	Auto	0.4	0.2	0.2	μs
Power-On Delay Time (Fast Start)	2 MHz	Auto	0.7	0.5	0.4	μs
Power-On Delay Time	25 MHz	Auto	0.01	0.05	0.04	μs
Frequency settling time	25 kHz	Auto	19	14	12	μs
	2 MHz	Auto	14	14	14	μs
Variable (CLK Period)	25 kHz	Forced	0-40	0-40	0-40	μs
	2 MHz	Forced	0-0.5	0-0.5	0-0.5	μs
	25 MHz	Forced	0-0.04	0-0.04	0-0.04	μs
Propagation Delay (Non-Delayed Edge)	25 kHz/ 2 MHz	Either	35	14	10	ns

3.4.8 25 kHz OSC0 Frequency Limits

Power Supply Range (V_{DD}), V	Temperature Range			
	+25 $^\circ\text{C}$		-40 $^\circ\text{C}$ to +85 $^\circ\text{C}$	
	Minimum Value, kHz	Maximum Value, kHz	Minimum Value, kHz	Maximum Value, kHz
1.8 V $\pm 5\%$	23.97	26.29	23.18	29.17
3.3 V $\pm 10\%$	24.49	25.63	23.89	27.00
5.0 V $\pm 10\%$	24.34	25.94	23.66	27.18
2.5 V to 4.5 V	24.48	25.65	23.87	27.04
1.71 V to 5.5 V	23.92	26.67	23.14	29.55

3.4.9 25 kHz OSC0 Frequency Error

Power Supply Range (V_{DD}), V	Temperature Range			
	+25 $^\circ\text{C}$		-40 $^\circ\text{C}$ to +85 $^\circ\text{C}$	
	Error (% at Minimum)	Error (% at Maximum)	Error (% at Minimum)	Error (% at Maximum)
1.8 V $\pm 5\%$	-4.12	5.15	-7.27	16.69
3.3 V $\pm 10\%$	-2.04	2.54	-4.44	8.01
5.0 V $\pm 10\%$	-2.64	3.76	-5.36	8.72
2.5 V to 4.5 V	-2.08	2.61	-4.50	8.15
1.71 V to 5.5 V	-4.32	6.68	-7.45	18.18

3.4.10 2 MHz OSC0 Frequency Limits

Power Supply Range (V _{DD}), V	Temperature Range			
	+25 °C		-40 °C to +85 °C	
	Minimum Value, MHz	Maximum Value, MHz	Minimum Value, MHz	Maximum Value, MHz
1.8 V ±5 %	1.94	2.04	1.87	2.06
3.3 V ±10 %	1.94	2.05	1.89	2.06
5.0 V ±10 %	1.92	2.21	1.86	2.24
2.5 V to 4.5 V	1.89	2.1	1.85	2.11
1.71 V to 5.5 V	1.78	2.22	1.54	2.25

3.4.11 2 MHz OSC0 Frequency Error

Power Supply Range (V _{DD}), V	Temperature Range			
	+25 °C		-40 °C to +85 °C	
	Error (% at Minimum)	Error (% at Maximum)	Error (% at Minimum)	Error (% at Maximum)
1.8 V ±5 %	-3.20	1.95	-6.35	3.15
3.3 V ±10 %	-2.90	2.40	-5.65	2.95
5.0 V ±10 %	-3.95	10.70	-7.15	12.05
2.5 V to 4.5 V	-5.75	4.75	-7.60	5.30
1.71 V to 5.5 V	-10.85	10.75	-23.05	12.30

3.4.12 25 MHz OSC1 Frequency Limits

Power Supply Range (V_{DD}), V	Temperature Range			
	+25 °C		-40 °C to +85 °C	
	Minimum Value, MHz	Maximum Value, MHz	Minimum Value, MHz	Maximum Value, MHz
2.5 V \pm 10 %	22.59	26.6	21.94	27.39
3.3 V \pm 10 %	23.94	25.87	22.99	26.47
5.0 V \pm 10 %	23.86	26.16	23.11	26.95
2.5 V to 4.5 V	21.84	25.87	21.23	26.47
1.71 V to 5.5 V	13.30	25.87	12.20	26.47

3.4.13 25 MHz OSC1 Frequency Error

Power Supply Range (V_{DD}), V	Temperature Range			
	+25 °C		-40 °C to +85 °C	
	Error (% at Minimum)	Error (% at Maximum)	Error (% at Minimum)	Error (% at Maximum)
2.5 V \pm 10 %	-9.66	6.32	-12.26	9.56
3.3 V \pm 10 %	-4.25	3.47	-8.04	5.90
5.0 V \pm 10 %	-4.56	4.62	-7.54	7.82
2.5 V to 4.5 V	-12.66	3.47	-15.08	5.90
1.71 V to 5.5 V	-46.79	3.47	-51.20	5.90

Note: 25 MHz OSC1 performance is not guaranteed at $V_{DD} < 2.5$ V.

3.4.14 OSCs Power-On Delay (Normal Mode)

Note: DLY/CNT Counter Data = 100, OSC Power Setting: "Auto Power-On", OSC Clock to Matrix Input: "Enable".

Typical values are at $T_A = +25\text{ }^\circ\text{C}$, unless otherwise specified.

Power Supply Range (V_{DD}) V	OSC0 2 MHz		OSC0 25 kHz		OSC1 25MHz
	Typical Value, ns	Maximum Value, ns	Typical Value, μs	Maximum Value, μs	Typical Value, ns
1.80	594	673	1.29	17.07	71
3.30	484	537	4.63	10.90	56
5.00	445	488	1.76	2.12	44

3.4.15 OSCs Power-On Delay (Fast Start-Up Time Mode)

Typical values are at $T_A = +25\text{ }^\circ\text{C}$, unless otherwise specified.

Power Supply Range (V_{DD}) V	OSC0 2 MHz		OSC0 25 kHz	
	Typical Value, ns	Maximum Value, ns	Typical Value, μs	Maximum Value, μs
1.80	556	1642	10.43	21.13
3.30	654	953	20.31	21.50
5.00	667	1097	20.37	21.43

3.4.16 ACMP Specifications

$T_A = -40\text{ }^\circ\text{C}$ to $+85\text{ }^\circ\text{C}$, $V_{DD} = 2.3\text{ V}$ to 5.5 V , unless otherwise noted.

Parameter	Symbol	Note	Conditions	Min	Typ	Max	Unit
ACMP Input Voltage Range	V_{ACMP}	Positive Input	$V_{DD} = 1.8\text{ V} \pm 5\%$	0	-	V_{DD}	V
		Negative Input		0	-	1.2	V
		Positive Input	$V_{DD} = 3.3\text{ V} \pm 10\%$	0	-	V_{DD}	V
		Negative Input		0	-	1.2	V
		Positive Input	$V_{DD} = 5.0\text{ V} \pm 10\%$	0	-	V_{DD}	V
		Negative Input		0	-	1.2	V
ACMP Input Offset Voltage	V_{offset}	Low Bandwidth - Enable, $V_{hys} = 0\text{ mV}$, Gain = 1, $V_{REF} = 50\text{ mV}$ to 1200 mV , $V_{DD} = 1.71\text{ V}$ to 5.5 V	$T_A = +25\text{ }^\circ\text{C}$	-10.7	-	8.4	mV
			$T_A = -40\text{ }^\circ\text{C}$ to $+85\text{ }^\circ\text{C}$	-10.9	-	7.0	mV
		Low Bandwidth - Disable, $V_{hys} = 0\text{ mV}$, Gain = 1, $V_{REF} = 50\text{ mV}$ to 1200 mV , $V_{DD} = 1.71\text{ V}$ to 5.5 V	$T_A = +25\text{ }^\circ\text{C}$	-10.2	-	9.1	mV
			$T_A = -40\text{ }^\circ\text{C}$ to $+85\text{ }^\circ\text{C}$	-10.8	-	10.0	mV

Parameter	Symbol	Note	Conditions	Min	Typ	Max	Unit
ACMP Start Time	t _{start}	ACMP Power-On delay, Minimal required wake time for the "Wake and Sleep function", Regulator and Charge Pump set to automatic ON/OFF	BG = 550 μs, T _A = +25 °C V _{DD} = 1.71 V to 5.5 V	-	673	1069	μs
			BG = 550 μs, T _A = -40 °C to +85 °C V _{DD} = 1.71 V to 5.5 V	-	677	1212	μs
			BG = 100 μs, T _A = +25 °C V _{DD} = 1.71 V to 5.5 V	-	135	208	μs
			BG = 100 μs, T _A = -40 °C to +85 °C V _{DD} = 1.71 V to 5.5 V	-	137	241	μs
ACMP Start Time	t _{start}	ACMP Power-On delay, Minimal required wake time for the "Wake and Sleep function", Regulator and Charge Pump always OFF	BG = 550 μs, T _A = +25 °C V _{DD} = 2.7 V to 5.5 V	-	673	1069	μs
			BG = 550 μs, T _A = -40 °C to +85 °C V _{DD} = 2.7 V to 5.5 V	-	677	1212	μs
			BG = 100 μs, T _A = +25 °C V _{DD} = 2.7 V to 5.5 V	-	133	207	μs
			BG = 100 μs, T _A = -40 °C to +85 °C V _{DD} = 2.7 V to 5.5 V	-	135	229	μs
Built-in Hysteresis	V _{HYS}	V _{HYS} = 25 mV V _{IL} = V _{in} - V _{HYS} /2 V _{IH} = V _{in} + V _{HYS} /2	LB - Enabled, T _A = +25 °C	7.32	-	39.18	mV
			LB - Disabled, T _A = +25 °C	10.0	-	37.74	mV
		V _{HYS} = 50 mV V _{IL} = V _{in} - V _{HYS} V _{IH} = V _{HYS}	LB - Enabled, T _A = +25 °C	38.76	-	54.41	mV
			LB - Disabled, T _A = +25 °C	41.20	-	52.91	mV
		V _{HYS} = 200 mV V _{IL} = V _{in} - V _{HYS} V _{IH} = V _{HYS}	LB - Enabled, T _A = +25 °C	187.52	-	205.29	mV
			LB - Disabled, T _A = +25 °C	190.37	-	203.29	mV
		V _{HYS} = 25 mV V _{IL} = V _{in} - V _{HYS} /2 V _{IH} = V _{in} + V _{HYS} /2	LB - Enabled T _A = -40 °C to +85 °C	0	-	48.66	mV
			LB - Disabled T _A = -40 °C to +85 °C	0	-	47.37	mV
		V _{HYS} = 50 mV V _{IL} = V _{in} - V _{HYS} V _{IH} = V _{HYS}	LB - Enabled T _A = -40 °C to +85 °C	22.50	-	55.87	mV
			LB - Disabled T _A = -40 °C to +85 °C	29.20	-	54.62	mV

Parameter	Symbol	Note	Conditions	Min	Typ	Max	Unit
Built-in Hysteresis	V _{HYS}	V _{HYS} = 200 mV V _{IL} = Vin - V _{HYS} V _{IH} = V _{HYS}	LB - Enabled T _A = -40 °C to +85 °C	157.10	-	206.21	mV
			LB - Disabled T _A = -40 °C to +85 °C	160.20	-	203.91	mV
Series Input Resistance	R _{sin}	Gain = 1x	-	-	100.0	-	MΩ
		Gain = 0.5x	-	-	1.0	-	MΩ
		Gain = 0.33x	-	-	0.7	-	MΩ
		Gain = 0.25x	-	-	1.0	-	MΩ
Propagation Delay, Response Time	PROP	Low Bandwidth - Enable, Gain = 1, V _{DD} = 1.71 V to 3.3 V, Overdrive = 10 mV, V _{REF} = 50 mV	Low to High, T _A = -40 °C to +85 °C	-	30	239	μs
			High to Low, T _A = -40 °C to +85 °C	-	31	245	μs
		Low Bandwidth - Enable, Gain = 1, V _{DD} = 1.71 V to 3.3 V, Overdrive = 100 mV, V _{REF} = 50 mV	Low to High, T _A = -40 °C to +85 °C	-	11	92	μs
			High to Low, T _A = -40 °C to +85 °C	-	13	106	μs
		Low Bandwidth - Disable, Gain = 1, V _{DD} = 1.71 V to 3.3 V, Overdrive = 10 mV, V _{REF} = 50 mV	Low to High, T _A = -40 °C to +85 °C	-	1.1	22	μs
			High to Low, T _A = -40 °C to +85 °C	-	1.1	8.4	μs
		Low Bandwidth - Disable, Gain = 1, V _{DD} = 1.71 V to 3.3 V, Overdrive = 100 mV, V _{REF} = 50 mV	Low to High, T _A = -40 °C to +85 °C	-	0.5	3.2	μs
			High to Low, T _A = -40 °C to +85 °C	-	0.6	4.5	μs
		Low Bandwidth - Enable, Gain = 1, V _{DD} = 3.3 V to 5.5 V, Overdrive = 10 mV, V _{REF} = 50 mV	Low to High, T _A = -40 °C to +85 °C	-	19	91	μs
			High to Low, T _A = -40 °C to +85 °C	-	20	97	μs
		Low Bandwidth - Enable, Gain = 1, V _{DD} = 3.3 V to 5.5 V, Overdrive = 100 mV, V _{REF} = 50 mV	Low to High, T _A = -40 °C to +85 °C	-	7.0	34	μs
			High to Low, T _A = -40 °C to +85 °C	-	8.3	43	μs
		Low Bandwidth - Disable, Gain = 1, V _{DD} = 3.3 V to 5.5 V, Overdrive = 10 mV, V _{REF} = 50 mV	Low to High, T _A = -40 °C to +85 °C	-	0.9	2.0	μs
			High to Low, T _A = -40 °C to +85 °C	-	1.0	1.6	μs
		Low Bandwidth - Disable, Gain = 1, V _{DD} = 3.3 V to 5.5 V, Overdrive = 100 mV, V _{REF} = 50 mV	Low to High, T _A = -40 °C to +85 °C	-	0.4	1.2	μs
			High to Low, T _A = -40 °C to +85 °C	-	0.5	0.8	μs

Parameter	Symbol	Note	Conditions	Min	Typ	Max	Unit
Propagation Delay, Response Time	PROP	Low Bandwidth - Enable, Gain = 1, $V_{DD} = 1.71\text{ V to }3.3\text{ V}$, Overdrive = 10 mV, $V_{REF} = 250\text{ mV}$	Low to High, $T_A = -40\text{ }^\circ\text{C to }+85\text{ }^\circ\text{C}$	-	30	242	μs
			High to Low, $T_A = -40\text{ }^\circ\text{C to }+85\text{ }^\circ\text{C}$	-	32	249	μs
		Low Bandwidth - Enable, Gain = 1, $V_{DD} = 1.71\text{ V to }3.3\text{ V}$, Overdrive = 100 mV, $V_{REF} = 250\text{ mV}$	Low to High, $T_A = -40\text{ }^\circ\text{C to }+85\text{ }^\circ\text{C}$	-	11	94	μs
			High to Low, $T_A = -40\text{ }^\circ\text{C to }+85\text{ }^\circ\text{C}$	-	10	83	μs
		Low Bandwidth - Disable, Gain = 1, $V_{DD} = 1.71\text{ V to }3.3\text{ V}$, Overdrive = 10 mV, $V_{REF} = 250\text{ mV}$	Low to High, $T_A = -40\text{ }^\circ\text{C to }+85\text{ }^\circ\text{C}$	-	1.2	2.0	μs
			High to Low, $T_A = -40\text{ }^\circ\text{C to }+85\text{ }^\circ\text{C}$	-	1.2	2.2	μs
		Low Bandwidth - Disable, Gain = 1, $V_{DD} = 1.71\text{ V to }3.3\text{ V}$, Overdrive = 100 mV, $V_{REF} = 250\text{ mV}$	Low to High, $T_A = -40\text{ }^\circ\text{C to }+85\text{ }^\circ\text{C}$	-	0.4	0.7	μs
			High to Low, $T_A = -40\text{ }^\circ\text{C to }+85\text{ }^\circ\text{C}$	-	0.4	0.7	μs
		Low Bandwidth - Enable, Gain = 1, $V_{DD} = 3.3\text{ V to }5.5\text{ V}$, Overdrive = 10 mV, $V_{REF} = 250\text{ mV}$	Low to High, $T_A = -40\text{ }^\circ\text{C to }+85\text{ }^\circ\text{C}$	-	19	92	μs
			High to Low, $T_A = -40\text{ }^\circ\text{C to }+85\text{ }^\circ\text{C}$	-	21	99	μs
		Low Bandwidth - Enable, Gain = 1, $V_{DD} = 3.3\text{ V to }5.5\text{ V}$, Overdrive = 100 mV, $V_{REF} = 250\text{ mV}$	Low to High, $T_A = -40\text{ }^\circ\text{C to }+85\text{ }^\circ\text{C}$	-	7	35	μs
			High to Low, $T_A = -40\text{ }^\circ\text{C to }+85\text{ }^\circ\text{C}$	-	6.5	33	μs
		Low Bandwidth - Disable, Gain = 1, $V_{DD} = 3.3\text{ V to }5.5\text{ V}$, Overdrive = 10 mV, $V_{REF} = 250\text{ mV}$	Low to High, $T_A = -40\text{ }^\circ\text{C to }+85\text{ }^\circ\text{C}$	-	1.1	1.9	μs
			High to Low, $T_A = -40\text{ }^\circ\text{C to }+85\text{ }^\circ\text{C}$	-	1.2	2.1	μs
		Low Bandwidth - Disable, Gain = 1, $V_{DD} = 3.3\text{ V to }5.5\text{ V}$, Overdrive = 100 mV, $V_{REF} = 250\text{ mV}$	Low to High, $T_A = -40\text{ }^\circ\text{C to }+85\text{ }^\circ\text{C}$	-	0.4	0.6	μs
			High to Low, $T_A = -40\text{ }^\circ\text{C to }+85\text{ }^\circ\text{C}$	-	0.3	0.6	μs
		Low Bandwidth - Enable, Gain = 1, $V_{DD} = 1.71\text{ V to }3.3\text{ V}$, Overdrive = 10 mV, $V_{REF} = 600\text{ mV}$	Low to High, $T_A = -40\text{ }^\circ\text{C to }+85\text{ }^\circ\text{C}$	-	31	246	μs
			High to Low, $T_A = -40\text{ }^\circ\text{C to }+85\text{ }^\circ\text{C}$	-	33	258	μs
		Low Bandwidth - Enable, Gain = 1, $V_{DD} = 1.71\text{ V to }3.3\text{ V}$, Overdrive = 100 mV, $V_{REF} = 600\text{ mV}$	Low to High, $T_A = -40\text{ }^\circ\text{C to }+85\text{ }^\circ\text{C}$	-	11	96	μs
			High to Low, $T_A = -40\text{ }^\circ\text{C to }+85\text{ }^\circ\text{C}$	-	10	84	μs

Parameter	Symbol	Note	Conditions	Min	Typ	Max	Unit
Propagation Delay, Response Time	PROP	Low Bandwidth - Disable, Gain = 1, V _{DD} = 1.71 V to 3.3 V, Overdrive = 10 mV, V _{REF} = 600 mV	Low to High, T _A = -40 °C to +85 °C	-	1.4	2.9	µs
			High to Low, T _A = -40 °C to +85 °C	-	1.4	2.8	µs
		Low Bandwidth - Disable, Gain = 1, V _{DD} = 1.71 V to 3.3 V, Overdrive = 100 mV, V _{REF} = 600 mV	Low to High, T _A = -40 °C to +85 °C	-	0.4	0.7	µs
			High to Low, T _A = -40 °C to +85 °C	-	0.4	0.6	µs
		Low Bandwidth - Enable, Gain = 1, V _{DD} = 3.3 V to 5.5 V, Overdrive = 10 mV, V _{REF} = 600 mV	Low to High, T _A = -40 °C to +85 °C	-	20	93	µs
			High to Low, T _A = -40 °C to +85 °C	-	21	101	µs
		Low Bandwidth - Enable, Gain = 1, V _{DD} = 3.3 V to 5.5 V, Overdrive = 100 mV, V _{REF} = 600 mV	Low to High, T _A = -40 °C to +85 °C	-	7.2	35	µs
			High to Low, T _A = -40 °C to +85 °C	-	6.6	33	µs
		Low Bandwidth - Disable, Gain = 1, V _{DD} = 3.3 V to 5.5 V, Overdrive = 10 mV, V _{REF} = 600 mV	Low to High, T _A = -40 °C to +85 °C	-	1.3	2.8	µs
			High to Low, T _A = -40 °C to +85 °C	-	1.4	2.8	µs
		Low Bandwidth - Disable, Gain = 1, V _{DD} = 3.3 V to 5.5 V, Overdrive = 100 mV, V _{REF} = 600 mV	Low to High, T _A = -40 °C to +85 °C	-	0.4	0.6	µs
			High to Low, T _A = -40 °C to +85 °C	-	0.3	0.5	µs
		Low Bandwidth - Enable, Gain = 1, V _{DD} = 1.71 V to 3.3 V, Overdrive = 10 mV, V _{REF} = 850 mV	Low to High, T _A = -40 °C to +85 °C	-	32	252	µs
			High to Low, T _A = -40 °C to +85 °C	-	34	261	µs
		Low Bandwidth - Enable, Gain = 1, V _{DD} = 1.71 V to 3.3 V, Overdrive = 100 mV, V _{REF} = 850 mV	Low to High, T _A = -40 °C to +85 °C	-	12	97	µs
			High to Low, T _A = -40 °C to +85 °C	-	11	86	µs
		Low Bandwidth - Disable, Gain = 1, V _{DD} = 1.71 V to 3.3 V, Overdrive = 10 mV, V _{REF} = 850 mV	Low to High, T _A = -40 °C to +85 °C	-	1.5	3.4	µs
			High to Low, T _A = -40 °C to +85 °C	-	1.5	3.3	µs
		Low Bandwidth - Disable, Gain = 1, V _{DD} = 1.71 V to 3.3 V, Overdrive = 100 mV, V _{REF} = 850 mV	Low to High, T _A = -40 °C to +85 °C	-	0.4	0.7	µs
			High to Low, T _A = -40 °C to +85 °C	-	0.4	0.6	µs

Parameter	Symbol	Note	Conditions	Min	Typ	Max	Unit
Propagation Delay, Response Time	PROP	Low Bandwidth - Enable, Gain = 1, V _{DD} = 3.3 V to 5.5 V, Overdrive = 10 mV, V _{REF} = 850 mV	Low to High, T _A = -40 °C to +85 °C	-	20	95	μs
			High to Low, T _A = -40 °C to +85 °C	-	22	103	μs
		Low Bandwidth - Enable, Gain = 1, V _{DD} = 3.3 V to 5.5 V, Overdrive = 100 mV, V _{REF} = 850 mV	Low to High, T _A = -40 °C to +85 °C	-	7.3	36	μs
			High to Low, T _A = -40 °C to +85 °C	-	6.7	34	μs
		Low Bandwidth - Disable, Gain = 1, V _{DD} = 3.3 V to 5.5 V, Overdrive = 10 mV, V _{REF} = 850 mV	Low to High, T _A = -40 °C to +85 °C	-	1.4	3.4	μs
			High to Low, T _A = -40 °C to +85 °C	-	1.4	3.3	μs
		Low Bandwidth - Disable, Gain = 1, V _{DD} = 3.3 V to 5.5 V, Overdrive = 100 mV, V _{REF} = 850 mV	Low to High, T _A = -40 °C to +85 °C	-	0.4	0.5	μs
			High to Low, T _A = -40 °C to +85 °C	-	0.3	0.5	μs
		Low Bandwidth - Enable, Gain = 1, V _{DD} = 1.71 V to 3.3 V, Overdrive = 10 mV, V _{REF} = 1200 mV	Low to High, T _A = -40 °C to +85 °C	-	85	1210	μs
			High to Low, T _A = -40 °C to +85 °C	-	74	982	μs
		Low Bandwidth - Enable, Gain = 1, V _{DD} = 1.71 V to 3.3 V, Overdrive = 100 mV, V _{REF} = 1200 mV	Low to High, T _A = -40 °C to +85 °C	-	43	690	μs
			High to Low, T _A = -40 °C to +85 °C	-	12	113	μs
		Low Bandwidth - Disable, Gain = 1, V _{DD} = 1.71 V to 3.3 V, Overdrive = 10 mV, V _{REF} = 1200 mV	Low to High, T _A = -40 °C to +85 °C	-	57	1083	μs
			High to Low, T _A = -40 °C to +85 °C	-	25	779	μs
		Low Bandwidth - Disable, Gain = 1, V _{DD} = 1.71 V to 3.3 V, Overdrive = 100 mV, V _{REF} = 1200 mV	Low to High, T _A = -40 °C to +85 °C	-	33	651	μs
			High to Low, T _A = -40 °C to +85 °C	-	1.3	29	μs
		Low Bandwidth - Enable, Gain = 1, V _{DD} = 3.3 V to 5.5 V, Overdrive = 10 mV, V _{REF} = 1200 mV	Low to High, T _A = -40 °C to +85 °C	-	22	107	μs
			High to Low, T _A = -40 °C to +85 °C	-	23	114	μs
		Low Bandwidth - Enable, Gain = 1, V _{DD} = 3.3 V to 5.5 V, Overdrive = 100 mV, V _{REF} = 1200 mV	Low to High, T _A = -40 °C to +85 °C	-	8.0	40	μs
			High to Low, T _A = -40 °C to +85 °C	-	6.9	35	μs

Parameter	Symbol	Note	Conditions	Min	Typ	Max	Unit		
Propagation Delay, Response Time	PROP	Low Bandwidth - Disable, Gain = 1, V _{DD} = 3.3 V to 5.5 V, Overdrive = 10 mV, V _{REF} = 1200 mV	Low to High, T _A = -40 °C to +85 °C	-	2.6	12	μs		
			High to Low, T _A = -40 °C to +85 °C	-	2.2	11	μs		
		Low Bandwidth - Disable, Gain = 1, V _{DD} = 3.3 V to 5.5 V, Overdrive = 100 mV, V _{REF} = 1200 mV	Low to High, T _A = -40 °C to +85 °C	-	1.1	6.8	μs		
			High to Low, T _A = -40 °C to +85 °C	-	0.4	0.9	μs		
Gain error (including threshold and internal V _{REF} error), T _A = -40 °C to +85 °C	G	G = 1, V _{DD} = 1.71 V	V _{REF} = 50 mV to 1200 mV	-	1	-	-		
		G = 1, V _{DD} = 3.3 V		-	1	-	-		
		G = 1, V _{DD} = 5.5 V		-	1	-	-		
		G = 0.5, V _{DD} = 1.71 V		-7.15	-	9.90	%		
		G = 0.5, V _{DD} = 3.3 V		-6.80	-	7.75			
		G = 0.5, V _{DD} = 5.5 V		-6.37	-	7.72			
		G = 0.33, V _{DD} = 1.71 V		-5.60	-	11.33			
		G = 0.33, V _{DD} = 3.3 V		-3.68	-	6.27			
		G = 0.33, V _{DD} = 5.5 V		-5.20	-	7.37			
		G = 0.25, V _{DD} = 1.71 V		-5.94	-	7.71			
		G = 0.25, V _{DD} = 3.3 V		-5.91	-	7.35			
		G = 0.25, V _{DD} = 5.5 V		-5.79	-	5.48			
Internal V _{REF} error, V _{REF} = 1200 mV	V _{REF}	V _{DD} = 1.8 V ± 5 %	T _A = +25 °C	-0.58	-	0.67		%	
			T _A = -40 °C to +85 °C	-1.01	-	0.83			
		V _{DD} = 3.3 V ± 10 %	T _A = +25 °C	-0.59	-	0.58			
			T _A = -40 °C to +85 °C	-1.17	-	0.72			
		V _{DD} = 5.0 V ± 10 %	T _A = +25 °C	-0.67	-	0.60			
			T _A = -40 °C to +85 °C	-1.25	-	0.74			
		Internal V _{REF} error, V _{REF} = 1000 mV	V _{REF}	V _{DD} = 1.8 V ± 5 %	T _A = +25 °C	-0.57	-		0.80
					T _A = -40 °C to +85 °C	-1.14	-		1.00
V _{DD} = 3.3 V ± 10 %	T _A = +25 °C			-0.59	-	0.70			
	T _A = -40 °C to +85 °C			-1.04	-	0.90			
V _{DD} = 5.0 V ± 10 %	T _A = +25 °C			-0.67	-	0.60			
	T _A = -40 °C to +85 °C			-1.15	-	0.80			

Parameter	Symbol	Note	Conditions	Min	Typ	Max	Unit
Internal V_{REF} error, $V_{REF} = 500 \text{ mV}$	V_{REF}	$V_{DD} = 1.8 \text{ V} \pm 5 \%$	$T_A = +25 \text{ }^\circ\text{C}$	-0.64	-	0.80	%
			$T_A = -40 \text{ }^\circ\text{C to } +85 \text{ }^\circ\text{C}$	-1.20	-	0.80	
		$V_{DD} = 3.3 \text{ V} \pm 10 \%$	$T_A = +25 \text{ }^\circ\text{C}$	-0.63	-	0.63	
			$T_A = -40 \text{ }^\circ\text{C to } +85 \text{ }^\circ\text{C}$	-1.40	-	0.80	
		$V_{DD} = 5.0 \text{ V} \pm 10 \%$	$T_A = +25 \text{ }^\circ\text{C}$	-0.80	-	0.70	
			$T_A = -40 \text{ }^\circ\text{C to } +85 \text{ }^\circ\text{C}$	-1.40	-	0.80	

4. Input/Output Pins

The SLG46540 has eleven GPIO pins which can function as either a user defined Input or Output, as well as serving as a special function and one GPI Pin.

4.1 Input Modes

Each IO pin can be configured as a digital input pin with/without buffered Schmitt Trigger, or can also be configured as a low voltage digital input. Pins 4 and 5 can also be configured to serve as analog inputs to the on-chip comparators.

4.2 Output Modes

Pins 3, 4, 5, 6, 7, 8, 10, 11, 12, 13 and 14 can all be configured as digital output pins.

4.3 Pull-Up/Down Resistors

All IO pins have the option for user selectable resistors connected to the input structure. The selectable values on these resistors are 10 kΩ, 100 kΩ, and 1 MΩ. In the case of Pin 2, the resistors are fixed to a pull-down configuration. In the case of all other IO pins, the internal resistors can be configured as either pull-up or pull-downs.

4.4 GPI Structure

4.4.1 GPI Structure (for Pin 2)

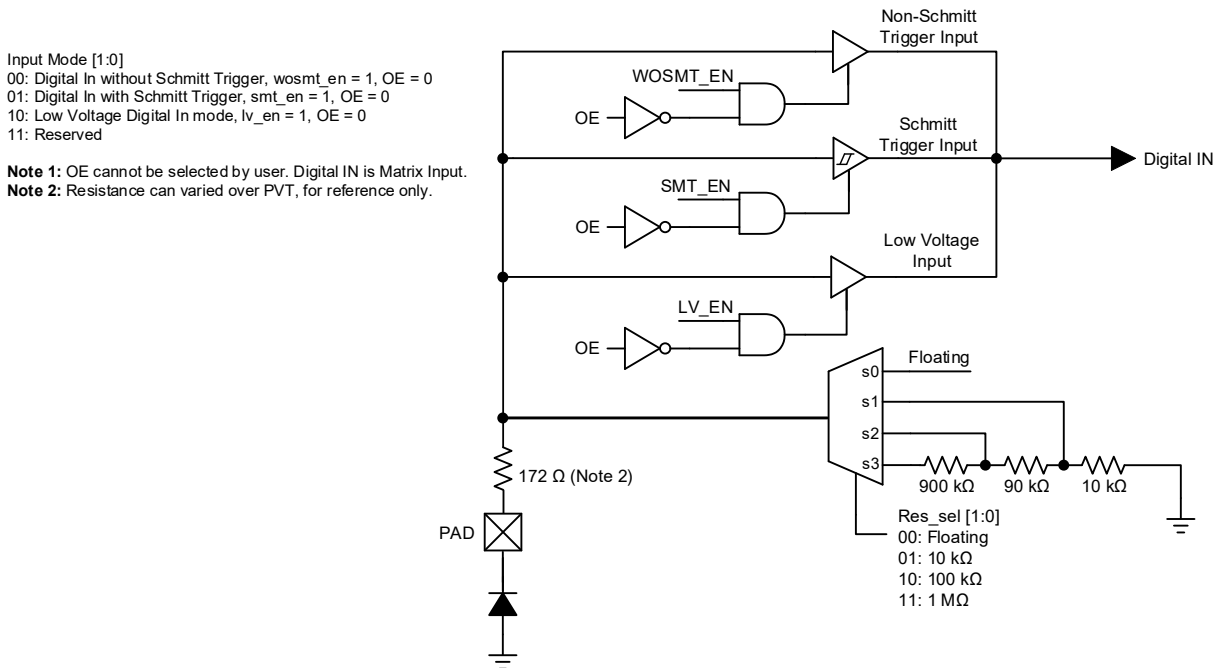

Figure 4. GPI Structure Diagram (Pin 2)

4.5 Matrix OE IO Structure

4.5.1 Matrix OE IO Structure (for Pin 5)

Input Mode [1:0]
 00: Digital In without Schmitt Trigger, wosmt_en = 1
 01: Digital In with Schmitt Trigger, smt_en = 1
 10: Low Voltage Digital In mode, lv_en = 1
 11: Analog IO mode

Output Mode [1:0]
 00: Push-Pull 1x mode, pp1x_en = 1
 01: Push-Pull 2x mode, pp2x_en = 1, pp1x_en = 1
 10: NMOS 1x Open-Drain mode, od1x_en = 1
 11: NMOS 2x Open-Drain mode, od2x_en = 1, od1x_en = 1

Note 1: Digital Out and OE are Matrix output, Digital In is Matrix input.
Note 2: Can be varied over PVT, for reference only.

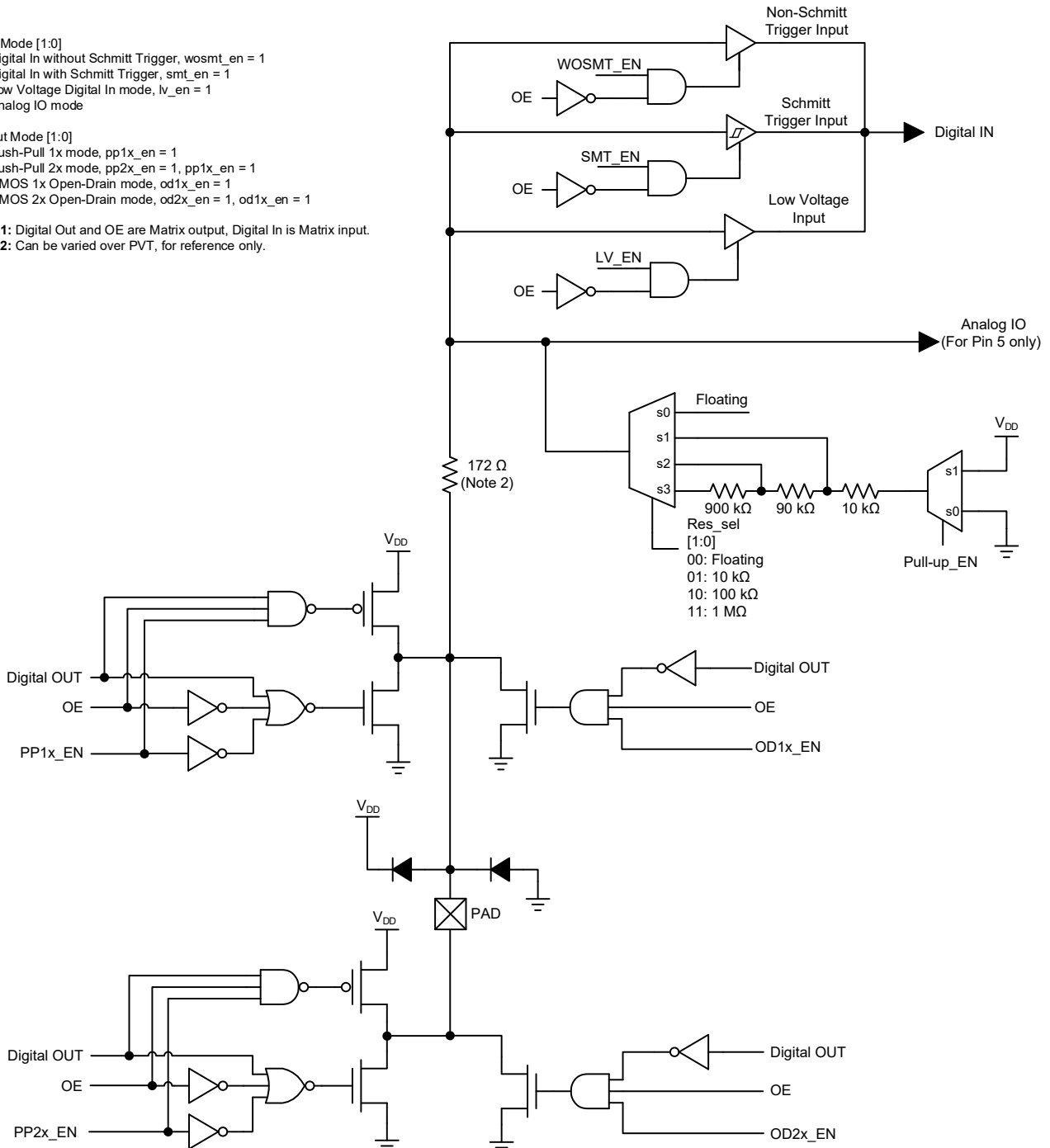

Figure 5. Matrix OE IO Structure Diagram (Pin 5)

4.5.2 Matrix OE IO Structure (for Pin 11)

Input Mode [1:0]
 00: Digital In without Schmitt Trigger, wosmt_en = 1
 01: Digital In with Schmitt Trigger, smt_en = 1
 10: Low Voltage Digital In mode, lv_en = 1
 11: Analog IO mode (except Pin 12)

Output Mode [1:0]
 00: Push-Pull 1x mode, pp1x_en = 1
 01: Push-Pull 2x mode, pp2x_en = 1, pp1x_en = 1
 10: NMOS 1x Open-Drain mode, od1x_en = 1
 11: NMOS 2x Open-Drain mode, od2x_en = 1, od1x_en = 1

Note 1: Digital OUT and OEB are controlled by register or Matrix Output. Digital IN is Matrix Input.

Note 2: Resistance can be varied over PVT, for reference only.

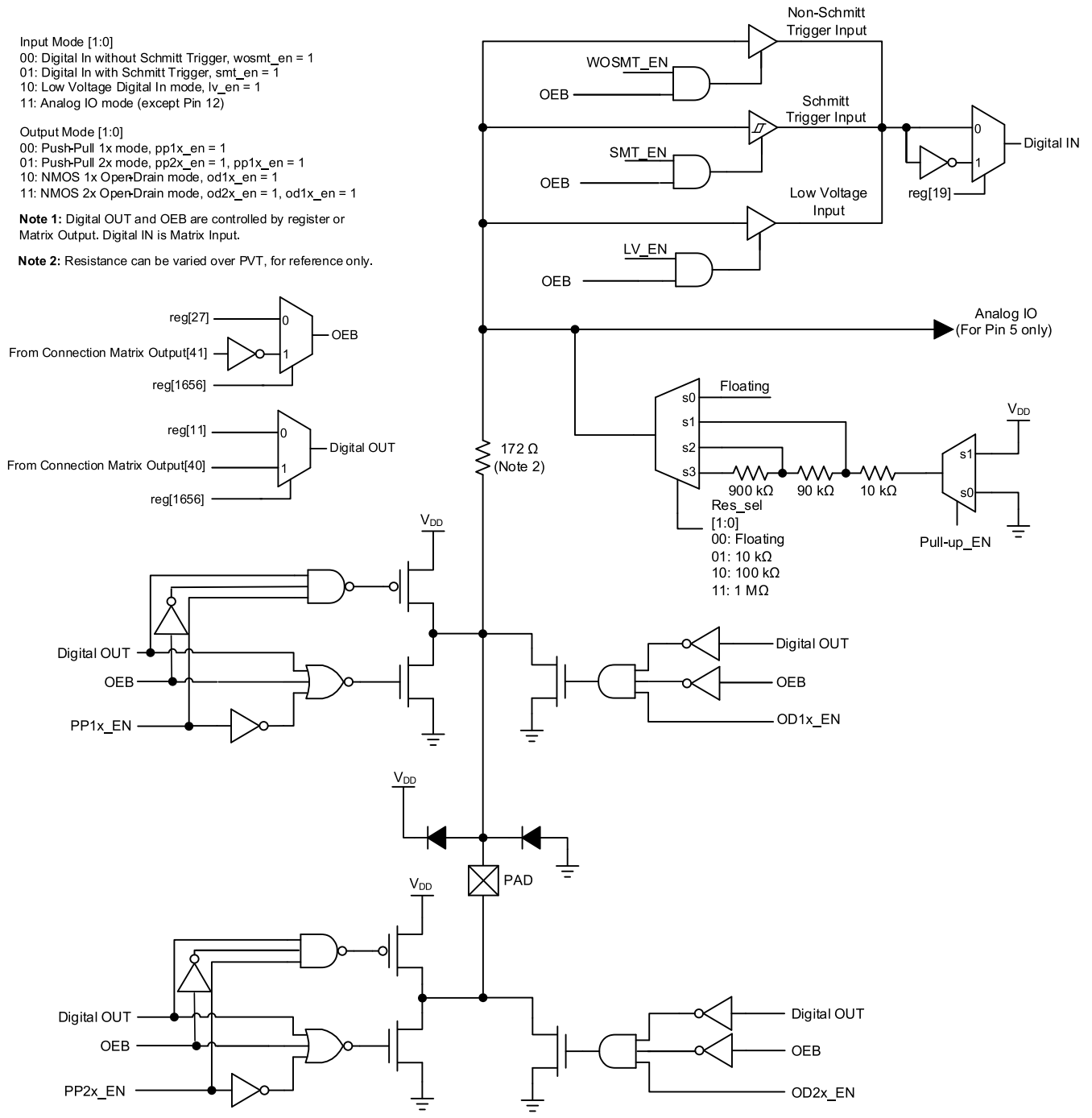

Figure 6. Matrix OE IO Structure Diagram (Pin 11)

4.5.3 Matrix OE IO Structure (for Pin 12)

Input Mode [1:0]
 00: Digital In without Schmitt Trigger, wosmt_en = 1
 01: Digital In with Schmitt Trigger, smt_en = 1
 10: Low Voltage Digital In mode, lv_en = 1
 11: Analog IO mode (except Pin 12)

Output Mode [1:0]
 00: Push-Pull 1x mode, pp1x_en = 1
 01: Push-Pull 2x mode, pp2x_en = 1, pp1x_en = 1
 10: NMOS 1x Open-Drain mode, od1x_en = 1
 11: NMOS 2x Open-Drain mode, od2x_en = 1, od1x_en = 1

Note 1: Digital OUT and OEB are controlled by register or Matrix Output. Digital IN is Matrix Input.

Note 2: Resistance can be varied over PVT, for reference only.

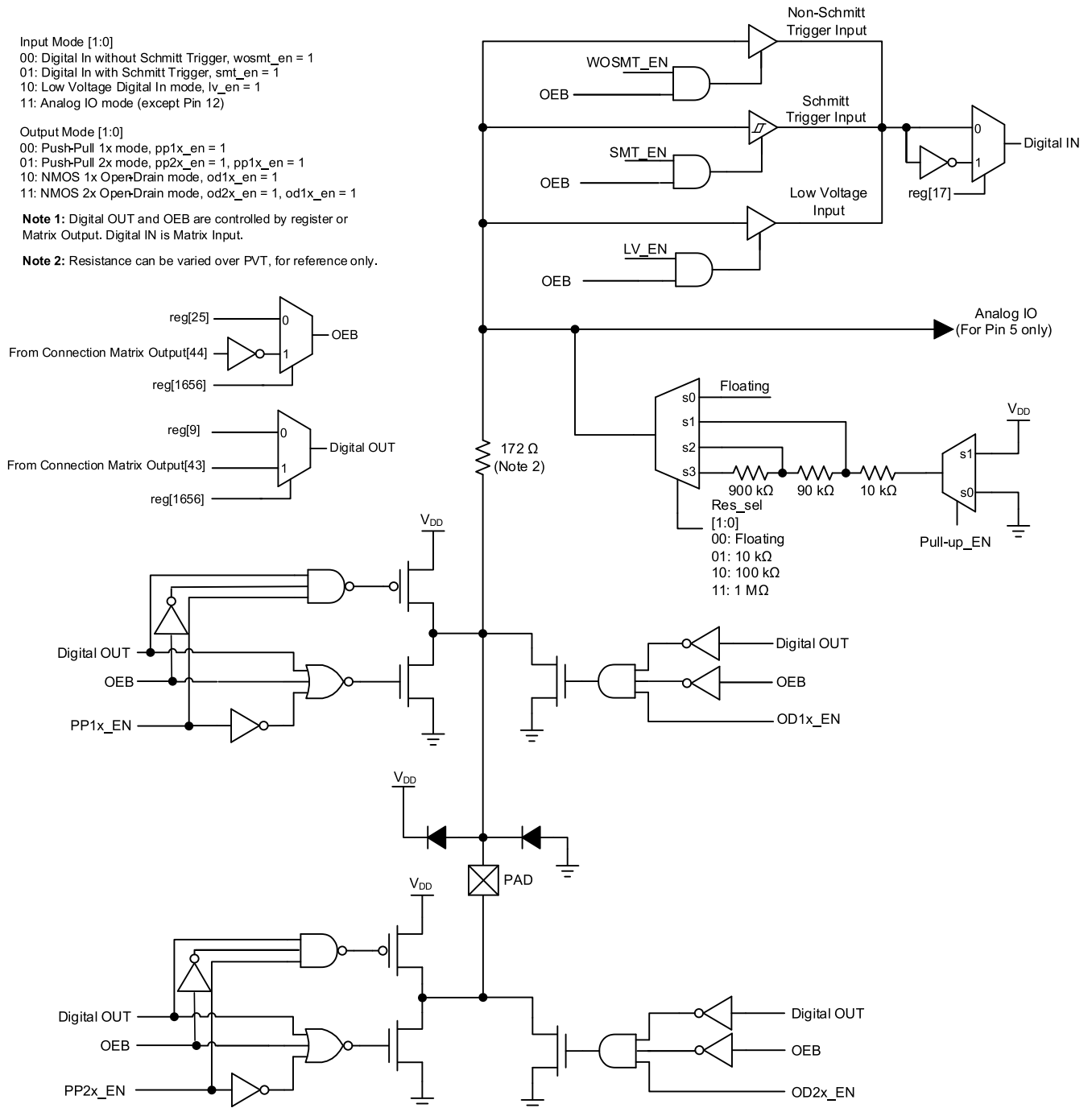

Figure 7. Matrix OE IO Structure Diagram (Pin 12)

4.5.4 Matrix OE IO Structure (for Pin 14)

Mode[2]
 0 : Push-pull mode, PP_EN=1, OEB=0
 1 : NMOS open drain mode, ODn_EN=1, OEB=0

Mode[1:0]
 00 : Digital In without Schmitt Trigger, WOSMT_EN=1, OEB=1
 01 : Digital In with Schmitt Trigger, SMT_EN=1, OEB=1
 10 : Low voltage Digital In mode, LV_EN=1, OEB=1
 11 : Reserved

Note 1: Digital OUT and OEB are controlled by register or Matrix Output. Digital IN is Matrix Input.
Note 2: Resistance can varied over PVT, for reference only.

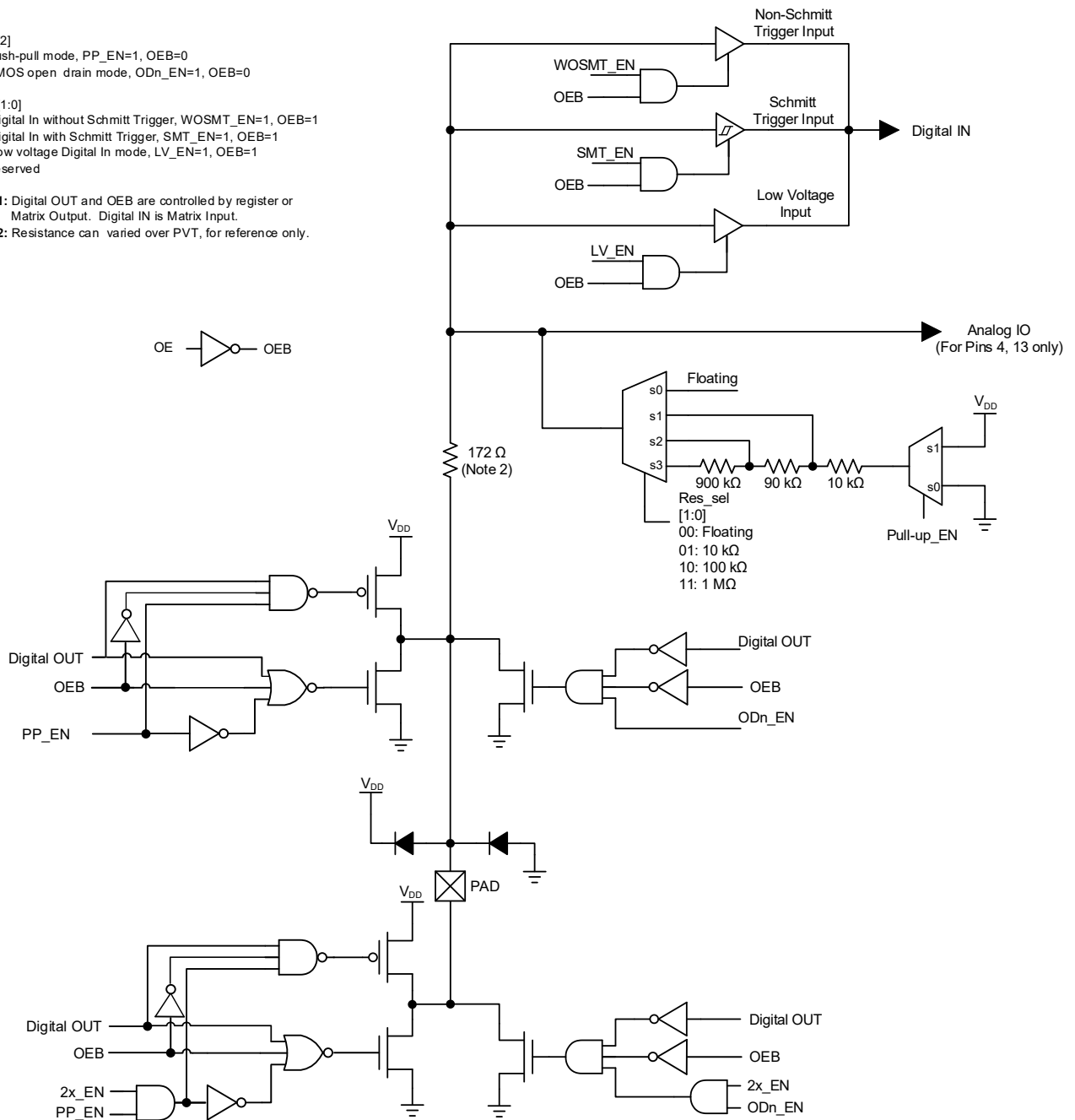

Figure 8. Matrix OE IO Structure Diagram (Pin 14)

4.5.5 Matrix OE 4x Drive Structure (for Pin 8)

Input Mode [1:0]
 XX: Digital In with Schmitt Trigger
 Output Mode [1:0]
 00: Push-Pull 1x mode, pp1x_en = 1
 01: Push-Pull 2x mode, pp2x_en = 1, pp1x_en = 1
 10: NMOS OpenDrain 1x mode, od1x_en = 1, odn_en = 1
 11: NMOS OpenDrain 2x mode, od2x_en = 1, od1x_en = 1, odn_en = 1

Note 1: Digital Out and OEB are controlled by register or Matrix Output Digital IN is Matrix Input
Note 2: Resistance can be varied over PVT, for reference only.

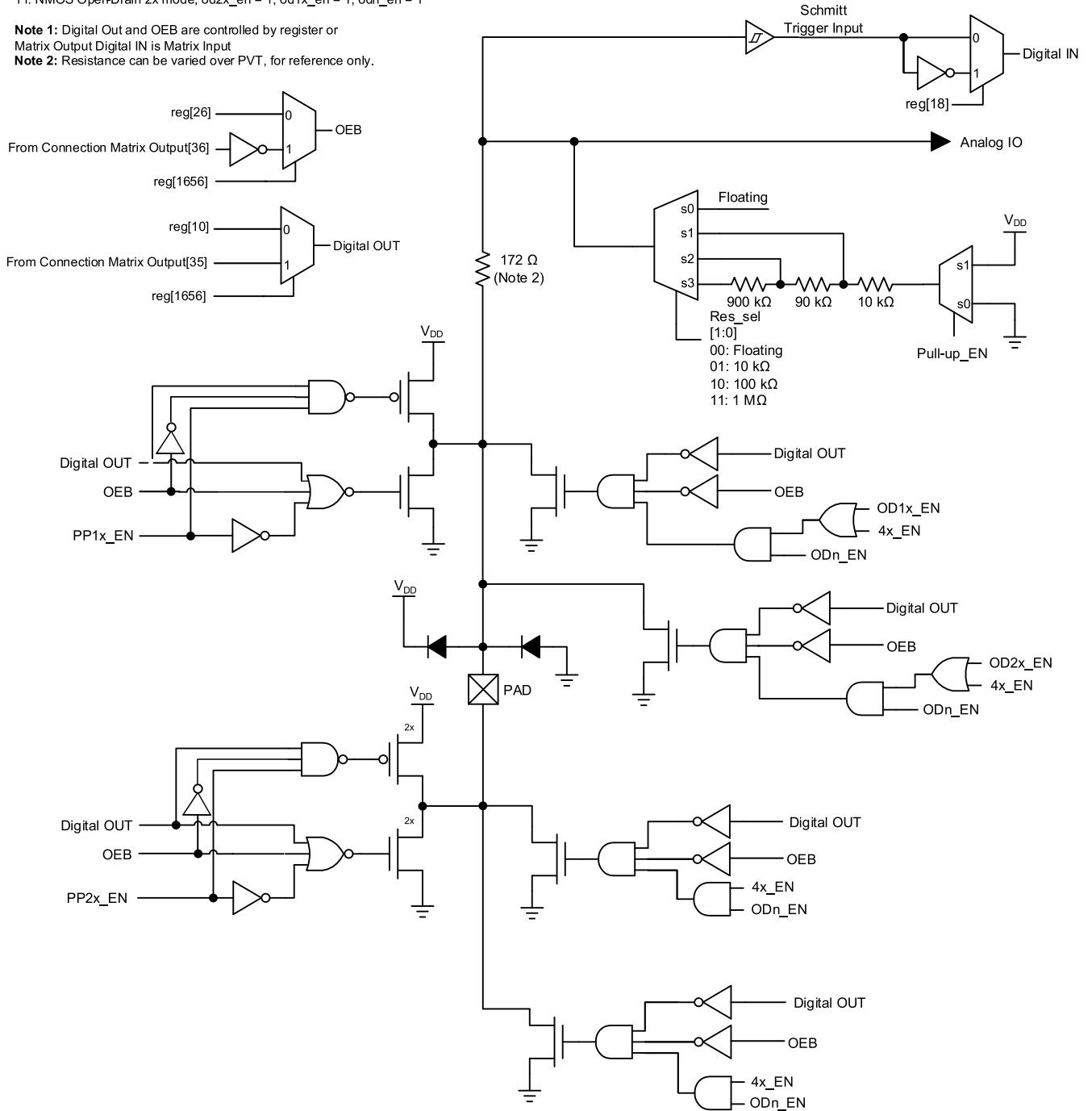

Figure 9. Matrix OE IO 4x Drive Structure Diagram (Pin 8)

4.5.6 Matrix OE 4x Drive Structure (for Pin 10)

Mode[2]

0 : Push-pull mode, PP_EN=1, OEB=0

1 : NMOS open drain mode, ODn_EN=1, OEB=0

Mode[1:0]

XX : Digital In with Schmitt Trigger

Note 1: Digital OUT and OEB are controlled by register or Matrix Output. Digital IN is Matrix Input.

Note 2: Resistance can be varied over PVT, for reference only.

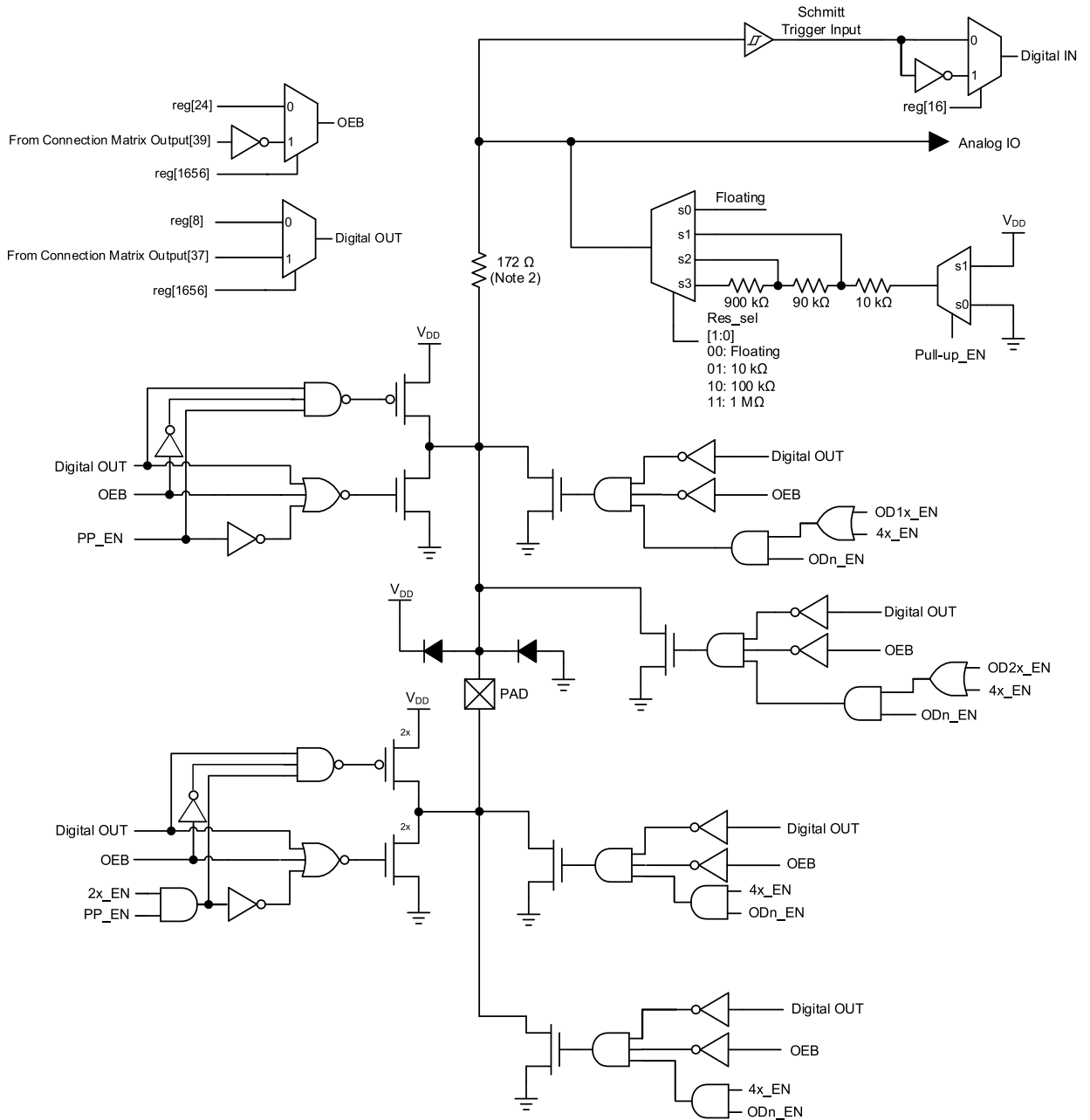

Figure 10. Matrix OE IO 4x Drive Structure Diagram (Pin 10)

4.6 IO Structure

4.6.1 IO Structure (for Pins 3, 4, 13)

Mode [2:0]
 000: Digital In without Schmitt Trigger, wosmt_en = 1, OE = 0
 001: Digital In with Schmitt Trigger, smt_en = 1, OE = 0
 010: Low Voltage Digital In mode, lv_en = 1, OE = 0
 011: Analog IO mode
 100: Push-Pull mode, pp_en = 1, OE = 1
 101: NMOS Open-Drain mode, odn_en = 1, OE = 1
 110: PMOS Open-Drain mode, odp_en = 1, OE = 1
 111: Analog IO and NMOS Open-Drain mode, odn_en = 1 and AIO_en = 1

Note 1: OE cannot be selected by user and is controlled by register.
 Note 2: Can be varied over PVT, for reference only.

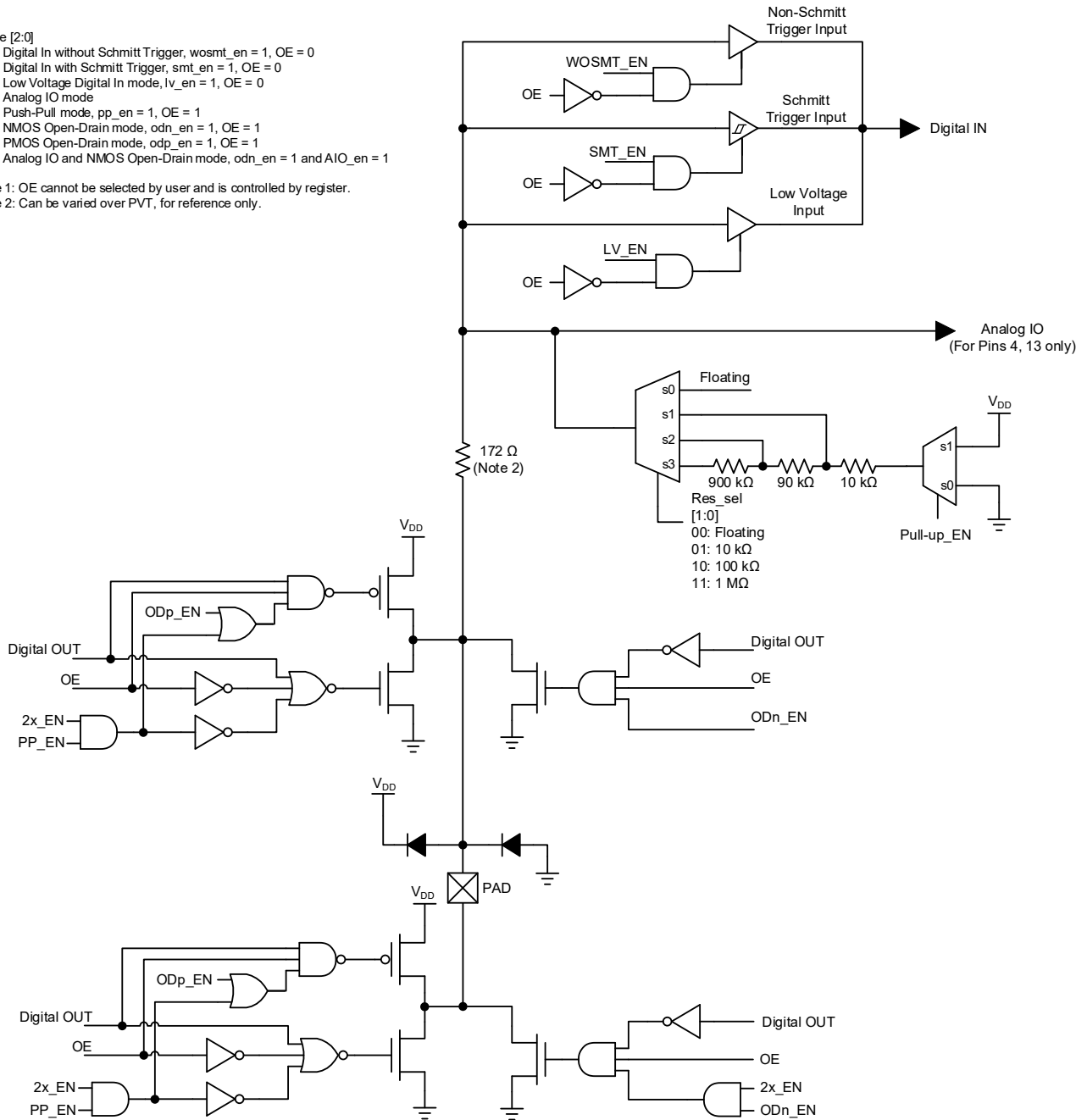

Figure 11. IO Structure Diagram (Pin 3, 4, 13)

4.6.2 IO Structure (for Pins 6 and 7)

Pin 6 and Pin 7 Mode [2:0]
 000: Digital Input without Schmitt Trigger
 001: Digital Input with Schmitt Trigger
 010: Low Voltage Digital Input
 011: Reserved
 100: Reserved
 101: Open-Drain NMOS
 110: Reserved
 111: Reserved

Note 1: OE is controlled by register.
Note 2: Resistance can be varied over PVT, for reference only.

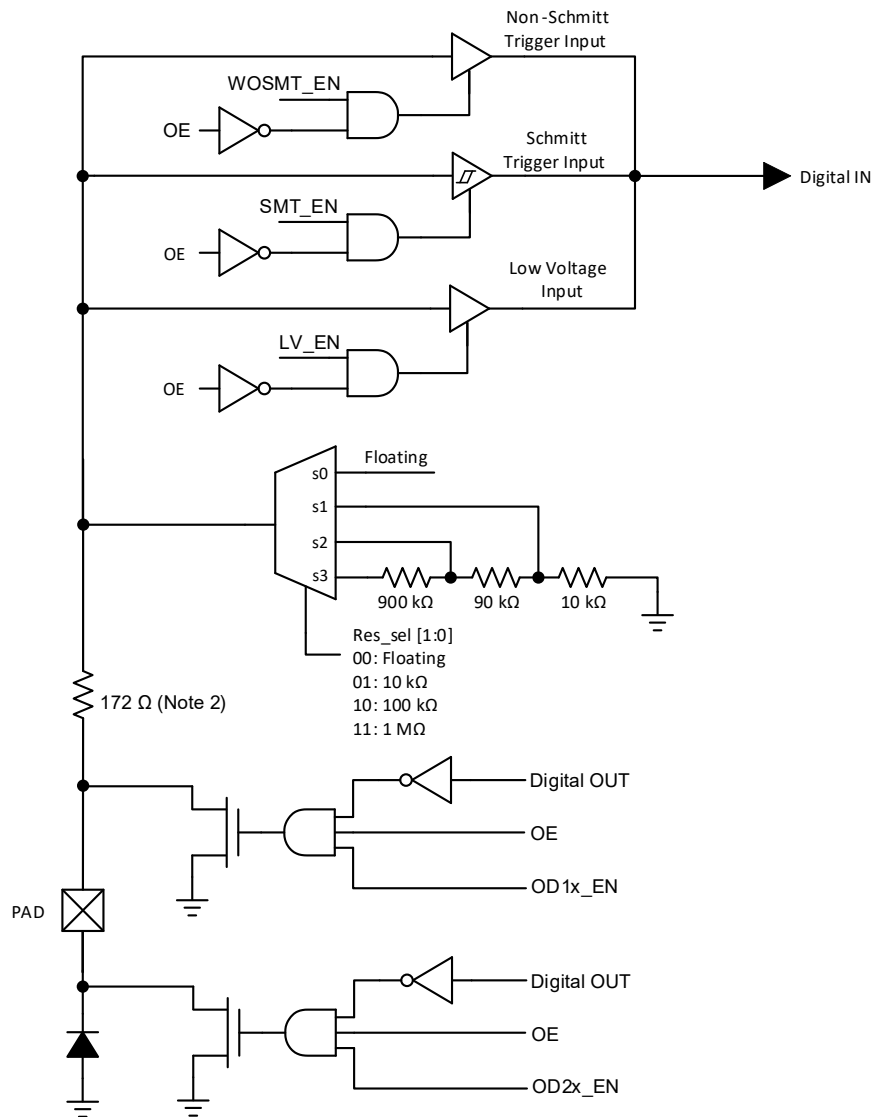

Figure 12. IO Structure Diagram (Pin 6, 7)

5. Connection Matrix

The Connection Matrix in the SLG46540 is used to create the internal routing for internal functional macrocells of the device once it is programmed. The registers are programmed from the one-time NVM cell during Test Mode Operation. The output of each functional macrocell within the SLG46540 has a specific digital bit code assigned to it that is either set to active “High” or inactive “Low” based on the design that is created. Once the 2048 register bits within the SLG46540 are programmed a fully custom circuit will be created.

The Connection Matrix has 64 inputs and 110 outputs. Each of the 64 inputs to the Connection Matrix is hard-wired to the digital output of a particular source macrocell, including IO pins, LUTs, analog comparators, other digital resources, such as VDD and GND. The input to a digital macrocell uses a 6-bit register to select one of these 64 input lines.

For a complete list of the SLG46540’s register table, see section [14 Register Definitions](#).

Matrix Input Signal	N				
GND	0				
PIN 2 Digital In	1				
PIN 3 Digital In	2				
PIN 4 Digital In	2				
⋮	⋮				
nReset_core	62				
V _{DD}	63				
Matrix Inputs Matrix Outputs	N	0	1	2	109
	Register	[5:0]	[13:8]	[21:16]	[877:872]
	Function	Matrix OUT: Reserved	Matrix OUT: Reserved	Matrix OUT: Reserved	Matrix OUT: Reserved

Figure 13. Connection Matrix

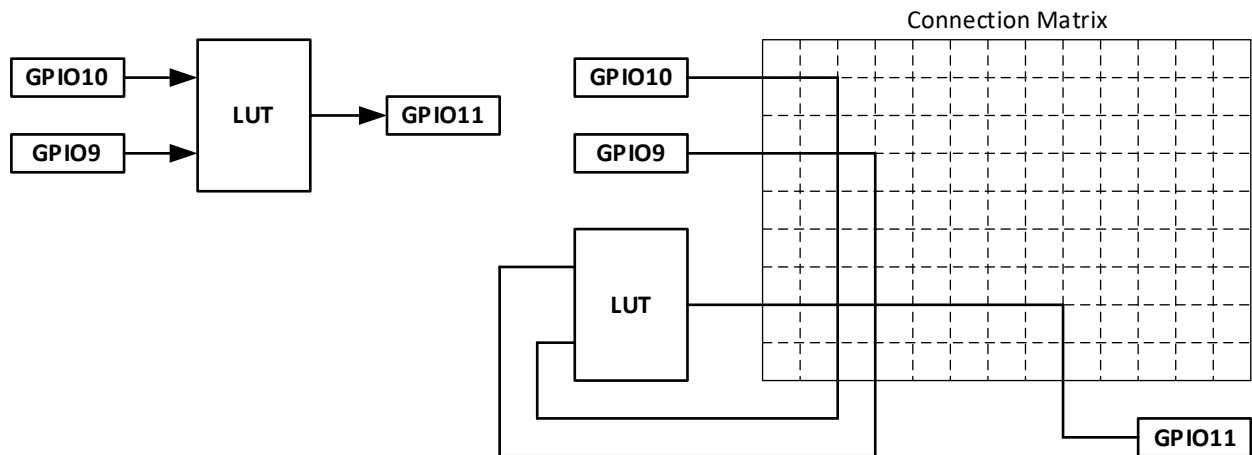

Figure 14. Connection Matrix Example

5.1 Matrix Input Table

Table 4. Matrix Input Table

Matrix Input Number	Matrix Input Signal Function	Matrix Decode					
		5	4	3	2	1	0
0	GND	0	0	0	0	0	0
1	Pin 2 Digital Input	0	0	0	0	0	1
2	Reserved	0	0	0	0	1	0
3	Pin 3 Digital Input	0	0	0	0	1	1
4	Reserved	0	0	0	1	0	0
5	Pin 4 Digital Input	0	0	0	1	0	1
6	Pin 5 Digital Input	0	0	0	1	1	0
7	Pin 8 Digital Input	0	0	0	1	1	1
8	2-bit LUT0/DFF0 Output	0	0	1	0	0	0
9	2-bit LUT1/DFF1 Output	0	0	1	0	0	1
10	2-bit LUT2/DFF2 Output	0	0	1	0	1	0
11	2-bit LUT3/PGen Output	0	0	1	0	1	1
12	3-bit LUT0/DFF3 Output	0	0	1	1	0	0
13	3-bit LUT1/DFF4 Output	0	0	1	1	0	1
14	3-bit LUT2/DFF5 Output	0	0	1	1	1	0
15	3-bit LUT3/DFF6 Output	0	0	1	1	1	1
16	3-bit LUT4/DFF7 Output	0	1	0	0	0	0
17	3-bit LUT5/CNT_DLY2 (8-bit) Output	0	1	0	0	0	1
18	3-bit LUT6/CNT_DLY3 (8-bit) Output	0	1	0	0	1	0
19	3-bit LUT7/CNT_DLY4 (8-bit) Output	0	1	0	0	1	1
20	3-bit LUT8/CNT_DLY5 (8-bit) Output	0	1	0	1	0	0
21	3-bit LUT9/CNT_DLY6 (8-bit) Output	0	1	0	1	0	1
22	4-bit LUT0/CNT_DLY0 (16-bit) Output	0	1	0	1	1	0
23	4-bit LUT1/CNT_DLY1 (16-bit) Output	0	1	0	1	1	1
24	3-bit LUT10/Pipe Delay (1st stage) Output	0	1	1	0	0	0
25	Pipe Delay Output0	0	1	1	0	0	1
26	Pipe Delay Output1	0	1	1	0	1	0
27	Internal OSC Pre-Divided by 1/2/4/8 Output and Post-Divided by 1/2/3/4/8/12/24/64 Output (25 kHz/2 MHz)	0	1	1	0	1	1
28	Internal OSC Pre-Divided by 1/2/4/8 Output and Post-Divided by 1/2/3/4/8/12/24/64 Output (25 kHz/2 MHz)	0	1	1	1	0	0
29	Internal OSC Pre-Divided by 1/2/4/8 Output (25 MHz)	0	1	1	1	0	1
30	Filter0/Edge Detect0 Output	0	1	1	1	1	0
31	Filter1/Edge Detect1 Output	0	1	1	1	1	1

Matrix Input Number	Matrix Input Signal Function	Matrix Decode					
		5	4	3	2	1	0
32	Reserved	1	0	0	0	0	0
33	Reserved	1	0	0	0	0	1
34	Reserved	1	0	0	0	1	0
35	Reserved	1	0	0	0	1	1
36	Reserved	1	0	0	1	0	0
37	Reserved	1	0	0	1	0	1
38	Reserved	1	0	0	1	1	0
39	Reserved	1	0	0	1	1	1
40	Reserved	1	0	1	0	0	0
41	Reserved	1	0	1	0	0	1
42	Reserved	1	0	1	0	1	0
43	Reserved	1	0	1	0	1	1
44	Reserved	1	0	1	1	0	0
45	Reserved	1	0	1	1	0	1
46	Reserved	1	0	1	1	1	0
47	Reserved	1	0	1	1	1	1
48	Pin 10 Digital Input	1	1	0	0	0	0
49	Reserved	1	1	0	0	0	1
50	Pin 11 Digital Input	1	1	0	0	1	0
51	Reserved	1	1	0	0	1	1
52	Pin 12 Digital Input	1	1	0	1	0	0
53	Pin 13 Digital Input	1	1	0	1	0	1
54	Reserved	1	1	0	1	1	0
55	Reserved	1	1	0	1	1	1
56	Pin 14 Digital Input	1	1	1	0	0	0
57	ACMP_0 Output	1	1	1	0	0	1
58	ACMP_1 Output	1	1	1	0	1	0
59	ACMP_2 Output	1	1	1	0	1	1
60	Reserved	1	1	1	1	0	0
61	Programmable Delay with Edge Detector Output	1	1	1	1	0	1
62	nRST_core (POR) as matrix input	1	1	1	1	1	0
63	VDD	1	1	1	1	1	1

5.2 Matrix Output Table

Table 5. Matrix Output Table

Register Bit Address	Matrix Output Signal Function	Matrix Output Number
[7:0]	Matrix OUT: Input Port Register	0
[15:8]	Matrix OUT: Output Port Register	1
[23:16]	Matrix OUT: Polarity Inversion Register	2
[31:24]	Matrix OUT: Configuration Register	3
[39:32]	Reserved	4
[47:40]	Reserved	5
[55:48]	Reserved	6
[63:56]	Reserved	7
[71:64]	Reserved	8
[79:72]	Reserved	9
[87:80]	Reserved	10
[95:88]	Reserved	11
[103:96]	Reserved	12
[111:104]	Reserved	13
[119:112]	Reserved	14
[127:120]	Reserved	15
[135:128]	Reserved	16
[143:136]	Reserved	17
[151:144]	Reserved	18
[159:152]	Reserved	19
[167:160]	Reserved	20
[175:168]	Reserved	21
[183:176]	Reserved	22
[191:184]	Reserved	23
[199:192]	Reserved	24
[207:200]	Reserved	25
[215:208]	Reserved	26
[223:216]	Matrix OUT: Pin 3 Digital Output Source	27
[231:224]	Reserved	28
[239:232]	Reserved	29
[247:240]	Matrix OUT: Pin 4 Digital Output Source	30
[255:248]	Matrix OUT: Pin 5 Digital Output Source	31
[263:256]	Matrix OUT: Pin 5 Output Enable	32
[271:264]	Matrix OUT: Pin 6 Digital Output Source (SCL with VI/Input and NMOS Open-Drain)	33

Register Bit Address	Matrix Output Signal Function	Matrix Output Number
[279:272]	Matrix OUT: Pin 7 Digital Output Source (SDA with VI/Input and NMOS Open-Drain)	34
[287:280]	reg [1656] = 0, Reserved reg [1656] = 1, PIN8 Digital Output Source	35
[295:288]	reg [1656] = 0, Reserved reg [1656] = 1, PIN8 Output Enable	36
[303:296]	reg [1656] = 0, Reserved reg [1656] = 1, PIN10 Digital Output Source	37
[311:304]	Reserved	38
[319:312]	reg [1656] = 0, Reserved reg [1656] = 1, PIN10 Output Enable	39
[327:320]	reg [1656] = 0, Reserved reg [1656] = 1, PIN11 Digital Output Source	40
[335:328]	reg [1656] = 0, Reserved reg [1656] = 1, PIN11 Output Enable	41
[343:336]	Reserved	42
[351:344]	reg [1656] = 0, Reserved reg [1656] = 1, PIN12 Digital Output Source	43
[359:352]	reg [1656] = 0, Reserved reg [1656] = 1, PIN12 Output Enable	44
[367:360]	Matrix OUT: Pin 13 Digital Output Source	45
[375:368]	Reserved	46
[383:376]	Reserved	47
[391:384]	Reserved	48
[399:392]	PIN14 Output Enable	49
[407:400]	PIN14 Digital Output Source	50
[415:408]	Matrix OUT: ACMP0 nPD (Power-Down)	51
[423:416]	Matrix OUT: ACMP1 nPD (Power-Down)	52
[431:424]	Matrix OUT: ACMP2 nPD (Power-Down)	53
[439:432]	Reserved	54
[447:440]	Matrix OUT: Input of Filter_0 with fixed time edge detector	55
[455:448]	Matrix OUT: Input of Filter_1 with fixed time edge detector	56
[463:456]	Matrix OUT: Input of Programmable Delay and Edge Detector	57
[471:464]	Matrix OUT: OSC 25 kHz/2 MHz PD (Power-Down)	58
[479:472]	Matrix OUT: OSC 25 MHz PD (Power-Down)	59
[487:480]	Matrix OUT: IN0 of 2-bit LUT0 or Clock Input of DFF0	60
[495:488]	Matrix OUT: IN1 of 2-bit LUT0 or Data Input of DFF0	61
[503:496]	Matrix OUT: IN0 of 2-bit LUT1 or Clock Input of DFF1	62
[511:504]	Matrix OUT: IN1 of 2-bit LUT1 or Data Input of DFF1	63

Register Bit Address	Matrix Output Signal Function	Matrix Output Number
[519:512]	Matrix OUT: IN0 of 2-bit LUT2 or Clock Input of DFF2	64
[527:520]	Matrix OUT: IN1 of 2-bit LUT2 or Data Input of DFF2	65
[535:528]	Matrix OUT: IN0 of 2-bit LUT3 or Clock Input of PGen	66
[543:536]	Matrix OUT: IN1 of 2-bit LUT3 or nRST of PGen	67
[551:544]	Matrix OUT: IN0 of 3-bit LUT0 or Clock Input of DFF3	68
[559:552]	Matrix OUT: IN1 of 3-bit LUT0 or Data Input of DFF3	69
[567:560]	Matrix OUT: IN2 of 3-bit LUT0 or nRST (nSET) of DFF3	70
[575:568]	Matrix OUT: IN0 of 3-bit LUT1 or Clock Input of DFF4	71
[583:576]	Matrix OUT: IN1 of 3-bit LUT1 or Data Input of DFF4	72
[591:584]	Matrix OUT: IN2 of 3-bit LUT1 or nRST (nSET) of DFF4	73
[599:592]	Matrix OUT: IN0 of 3-bit LUT2 or Clock Input of DFF5	74
[607:600]	Matrix OUT: IN1 of 3-bit LUT2 or Data Input of DFF5	75
[615:608]	Matrix OUT: IN2 of 3-bit LUT2 or nRST (nSET) of DFF5	76
[623:616]	Matrix OUT: IN0 of 3-bit LUT3 or Clock Input of DFF6	77
[631:624]	Matrix OUT: IN1 of 3-bit LUT3 or Data Input of DFF6	78
[639:632]	Matrix OUT: IN2 of 3-bit LUT3 or nRST (nSET) of DFF6	79
[647:640]	Matrix OUT: IN0 of 3-bit LUT4 or Clock Input of DFF7	80
[655:648]	Matrix OUT: IN1 of 3-bit LUT4 or Data Input of DFF7	81
[663:656]	Matrix OUT: IN2 of 3-bit LUT4 or nRST (nSET) of DFF7	82
[671:664]	Matrix OUT: IN0 of 3-bit LUT5 or Delay2 Input (or Counter2 RST Input)	83
[679:672]	Matrix OUT: IN1 of 3-bit LUT5 or External Clock Input of Delay2 (or Counter2)	84
[687:680]	Matrix OUT: IN2 of 3-bit LUT5	85
[695:688]	Matrix OUT: IN0 of 3-bit LUT6 or Delay3 Input (or Counter3 RST Input)	86
[703:696]	Matrix OUT: IN1 of 3-bit LUT6 or External Clock Input of Delay3 (or Counter3)	87
[711:704]	Matrix OUT: IN2 of 3-bit LUT6	88
[719:712]	Matrix OUT: IN0 of 3-bit LUT7 or Delay4 Input (or Counter4 RST Input)	89
[727:720]	Matrix OUT: IN1 of 3-bit LUT7 or External Clock Input of Delay4 (or Counter4)	90
[735:728]	Matrix OUT: IN2 of 3-bit LUT7	91
[743:736]	Matrix OUT: IN0 of 3-bit LUT8 or Delay5 Input (or Counter5 RST Input)	92
[751:744]	Matrix OUT: IN1 of 3-bit LUT8 or External Clock Input of Delay5 (or Counter5)	93
[759:752]	Matrix OUT: IN2 of 3-bit LUT8	94
[767:760]	Matrix OUT: IN0 of 3-bit LUT9 or Delay6 Input (or Counter6 RST Input)	95
[775:768]	Matrix OUT: IN1 of 3-bit LUT9 or External Clock Input of Delay6 (or Counter6)	96
[783:776]	Matrix OUT: IN2 of 3-bit LUT9	97
[791:784]	Matrix OUT: IN0 of 3-bit LUT10 or Input of Pipe Delay	98
[799:792]	Matrix OUT: IN1 of 3-bit LUT10 or nRST of Pipe Delay	99

Register Bit Address	Matrix Output Signal Function	Matrix Output Number
[807:800]	Matrix OUT: IN2 of 3-bit LUT10 or Clock of Pipe Delay	100
[815:808]	Matrix OUT: IN0 of 4-bit LUT0 or Delay0 Input (or Counter0 RST/SET Input)	101
[823:816]	Matrix OUT: IN1 of 4-bit LUT0 or External Clock Input of Delay0 (or Counter0)	102
[831:824]	Matrix OUT: IN2 of 4-bit LUT0 or UP Input of FSM0	103
[839:832]	Matrix OUT: IN3 of 4-bit LUT0 or KEEP Input of FSM0	104
[847:840]	Matrix OUT: IN0 of 4-bit LUT1 or Delay1 Input (or Counter1 RST/SET Input)	105
[855:848]	Matrix OUT: IN1 of 4-bit LUT1 or External Clock Input of Delay1 (or Counter1)	106
[863:856]	Matrix OUT: IN2 of 4-bit LUT1 or UP Input of FSM1	107
[871:864]	Matrix OUT: IN3 of 4-bit LUT1 or KEEP Input of FSM1	108
[879:872]	Reserved	109

1. For each address, the two most significant bits are unused.

5.3 Connection Matrix Virtual Outputs

The digital outputs of the various macrocells are routed to the Connection Matrix to enable interconnections to the inputs of other macrocells in the device. At the same time, it is possible to read the state of each of the macrocell outputs as a register value via I²C. This option, called Connection Matrix Virtual Outputs, allows the user to remotely read the values of each macrocell output. The I²C addresses for reading these register values are at byte 0000 and bytes 0240 to 0247. Write commands to these same register values will be ignored.

6. Combination Function Macrocells

The SLG46540 has seventeen combination function macrocells that can serve more than one logic or timing function. In each case, they can serve as a Look Up Table (LUT), or as another logic or timing function. See the list below for the functions that can be implemented in these macrocells.

- Three macrocells that can serve as either 2-bit LUTs or as D Flip-Flops.
- Five macrocells that can serve as either 3-bit LUTs or as D Flip-Flops with Set/Reset Input.
- One macrocell that can serve as either 3-bit LUT or as Pipe Delay.
- One macrocell that can serve as either 2-bit LUT or as Programmable Pattern Generator (PGen).
- Five macrocells that can serve as either 3-bit LUTs or as 8-Bit Counter/Delays.
- Two macrocells that can serve as either 4-bit LUTs or as 16-Bit Counter/Delays.

Inputs/Outputs for the 17 combination function macrocells are configured from the connection matrix with specific logic functions being defined by the state of NVM bits.

When used as a LUT to implement combinatorial logic functions, the outputs of the LUTs can be configured to any user defined function, including the following standard digital logic devices (AND, NAND, OR, NOR, XOR, XNOR).

6.1 2-Bit LUT or D Flip-Flop Macrocells

There are three macrocells that can serve as either 2-bit LUTs or as D Flip-Flops. When used to implement LUT functions, the 2-bit LUTs each take in two input signals from the connection matrix and produce a single output, which goes back into the connection matrix. When used to implement D Flip-Flop function, the two input signals from the connection matrix go to the data (D) and clock (CLK) inputs for the Flip-Flop, with the output going back to the connection matrix.

The operation of the D Flip-Flop and LATCH will follow the functional descriptions below:

- DFF: CLK is rising edge triggered, then Q = D; otherwise Q will not change.
- LATCH: when CLK is Low, then Q = D; otherwise Q remains its previous value (input D has no effect on the output, when CLK is High).

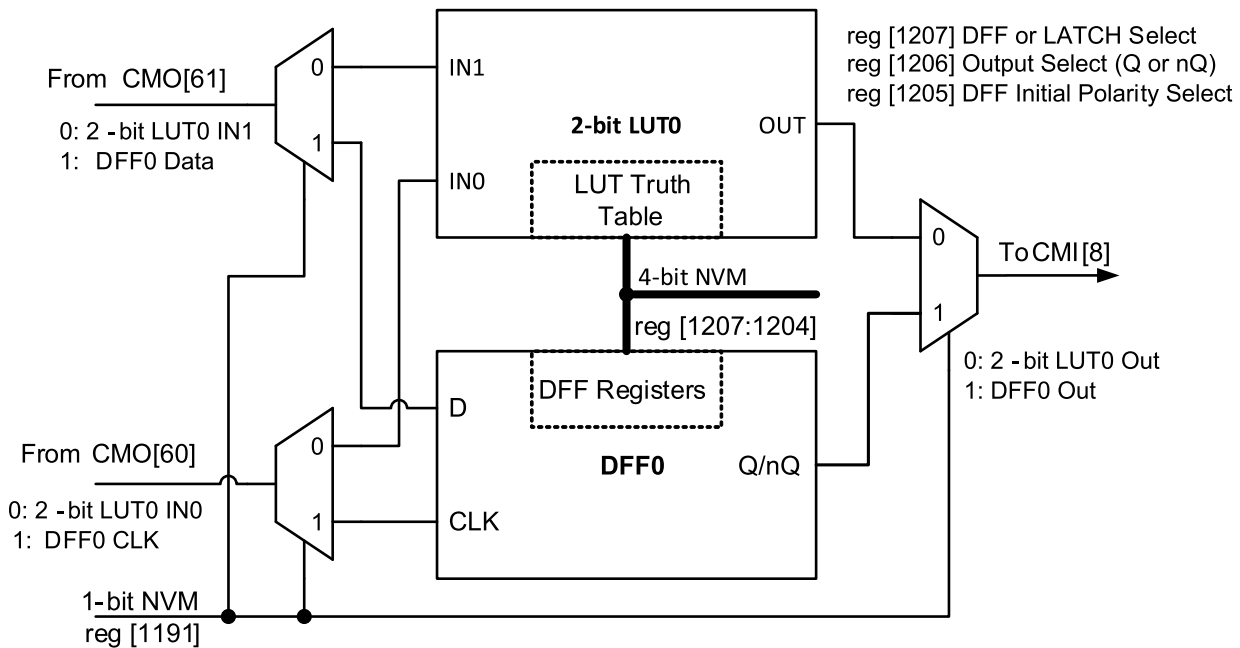

Figure 15. 2-bit LUT0 or DFF0

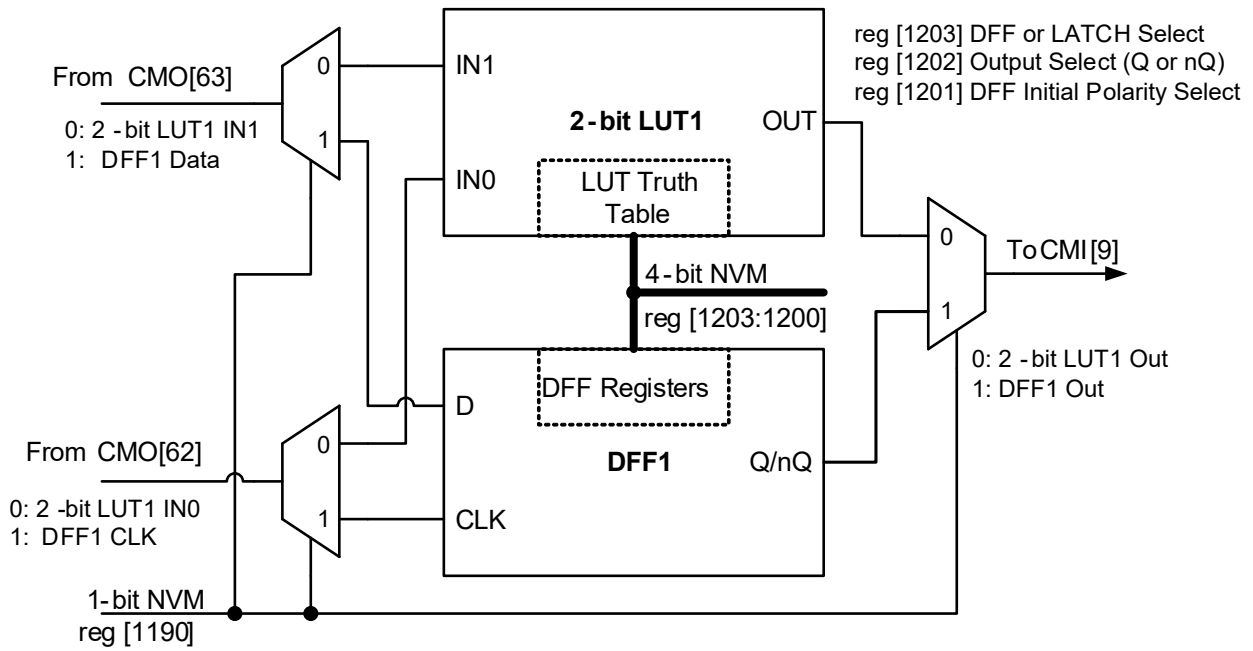

Figure 16. 2-bit LUT1 or DFF1

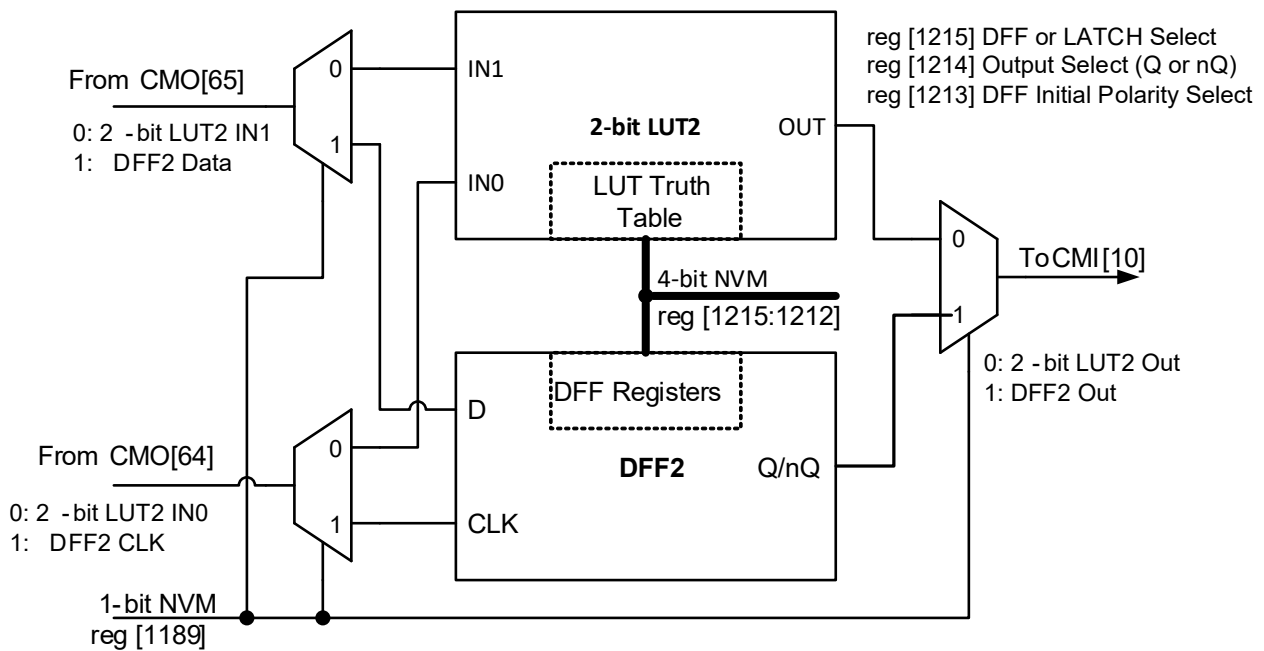

Figure 17. 2-bit LUT2 or DFF2

6.1.1 2-Bit LUT or D Flip-Flop Macrocells Used as 2-Bit LUTs

Table 6. 2-bit LUT0 Truth Table

IN1	IN0	OUT	
0	0	reg [1204]	LSB
0	1	reg [1205]	
1	0	reg [1206]	
1	1	reg [1207]	MSB

Table 7. 2-bit LUT1 Truth Table

IN1	IN0	OUT	
0	0	reg [1200]	LSB
0	1	reg [1201]	
1	0	reg [1202]	
1	1	reg [1203]	MSB

Table 8. 2-bit LUT2 Truth Table

IN1	IN0	OUT	
0	0	reg [1212]	LSB
0	1	reg [1213]	
1	0	reg [1214]	
1	1	reg [1215]	MSB

Each macrocell, when programmed for a LUT function, uses a 4-bit register to define their output function:

- 2-bit LUT0 is defined by reg [1207:1204]
- 2-bit LUT1 is defined by reg [1203:1200]
- 2-bit LUT2 is defined by reg [1215:1212].

Table 9 shows the register bits for the standard digital logic devices (AND, NAND, OR, NOR, XOR, XNOR) that can be created within each of the 2-bit LUT logic cells.

Table 9. 2-bit LUT Standard Digital Functions

Function	MSB			LSB
AND-2	1	0	0	0
NAND-2	0	1	1	1
OR-2	1	1	1	0
NOR-2	0	0	0	1
XOR-2	0	1	1	0
XNOR-2	1	0	0	1

6.1.2 Initial Polarity Operations

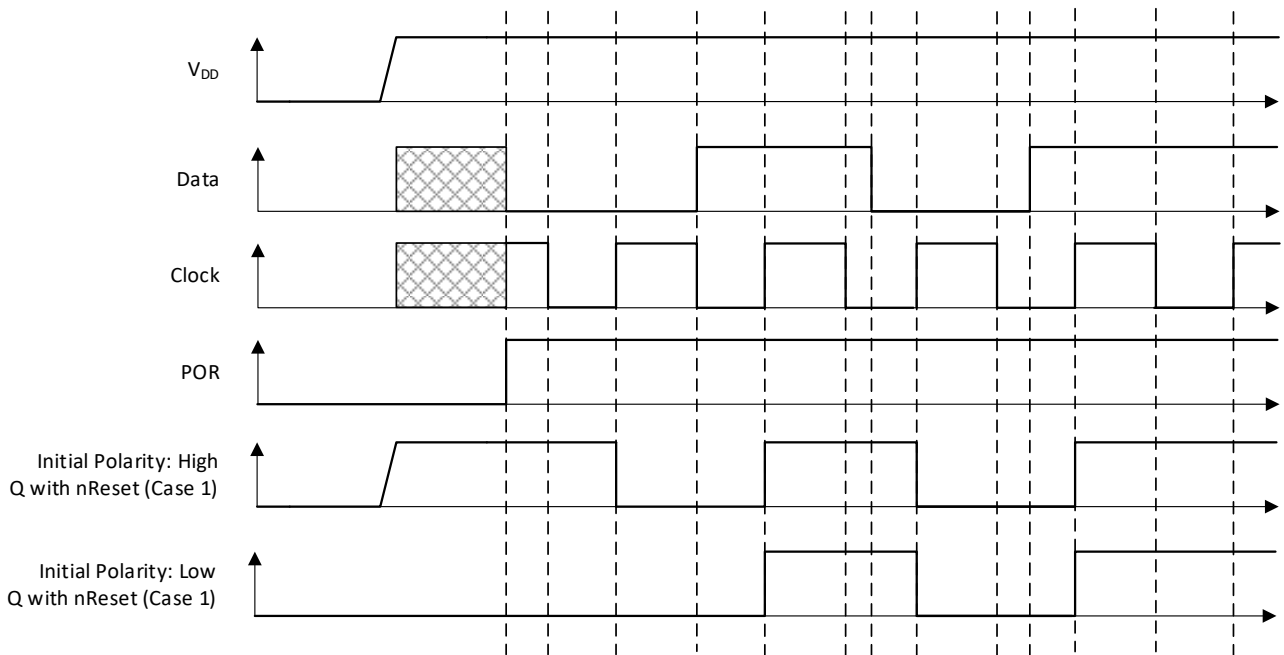

Figure 18. DFF Polarity Operations

6.2 3-Bit LUT or D Flip-Flop with Set/Reset Macrocells

There are five macrocells that can serve as either 3-bit LUTs or as D Flip-Flops with Set/Reset inputs. When used to implement LUT functions, the 3-bit LUTs each take in three input signals from the connection matrix and produce a single output, which goes back into the connection matrix. When used to implement D Flip-Flop function, the three input signals from the connection matrix go to the data (D) and clock (CLK), and Reset/Set (nRST/nSET) inputs for the Flip-Flop, with the output going back to the connection matrix.

DFF3 has a user selectable option to allow the macrocell output to either come from the Q/nQ output of one D Flip-Flop, or two D Flip-Flops in series, with the first D Flip-Flop triggering on the rising clock edge, and the second D Flip-Flop triggering on the falling clock edge.

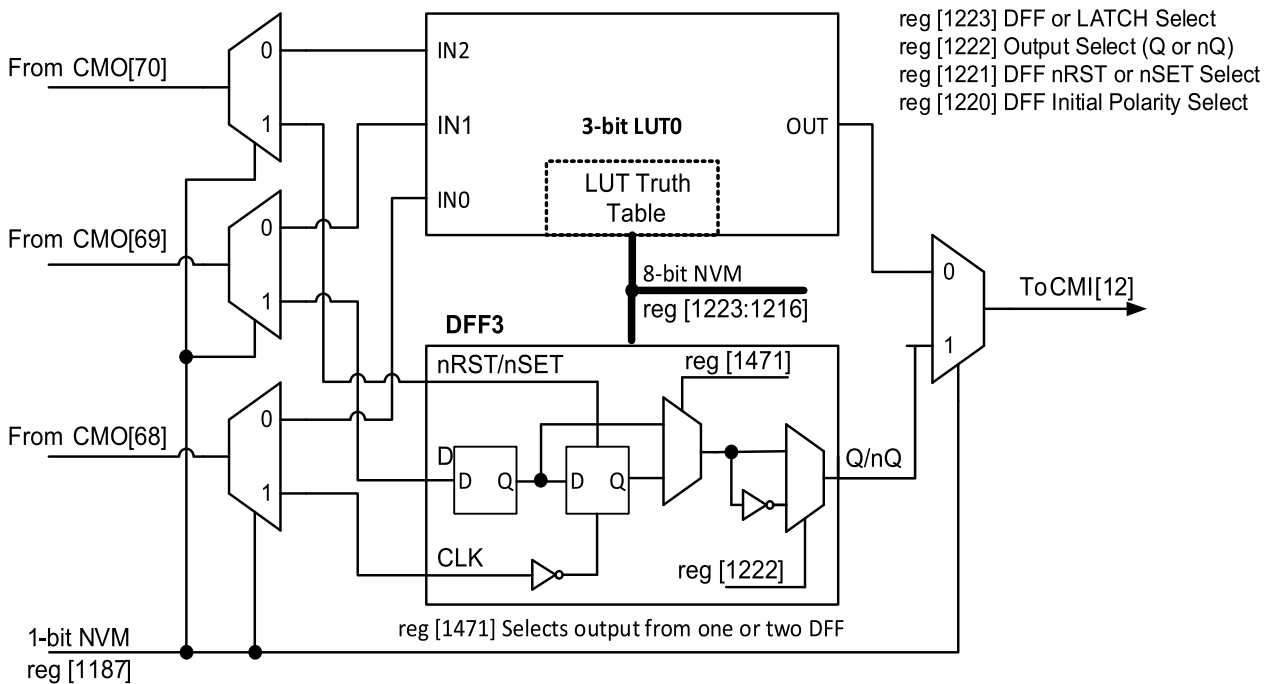

Figure 19. 3-bit LUT0 or DFF3 with RST/SET

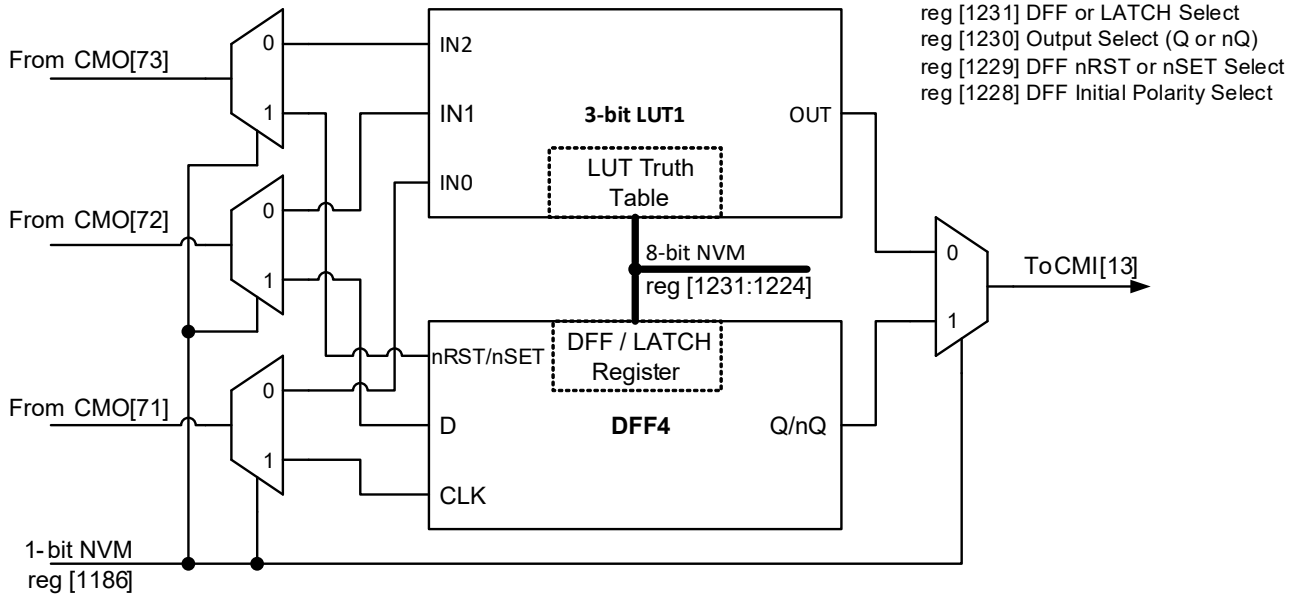

Figure 20. 3-bit LUT1 or DFF4 with RST/SET

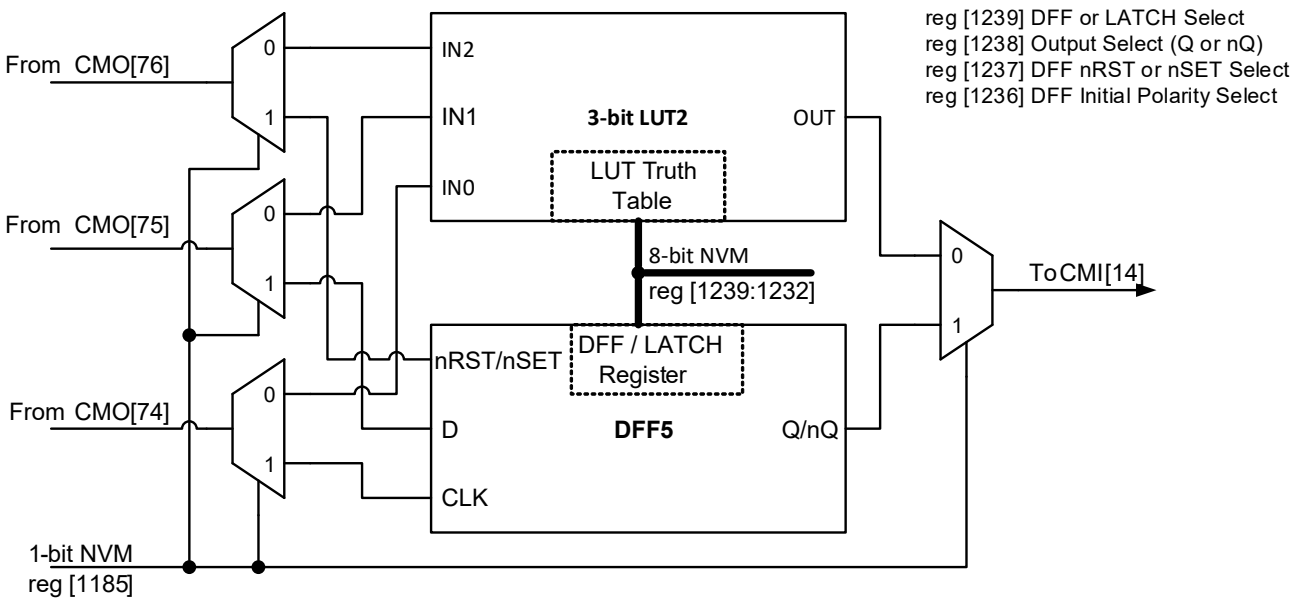

Figure 21. 3-bit LUT2 or DFF5 with RST/SET

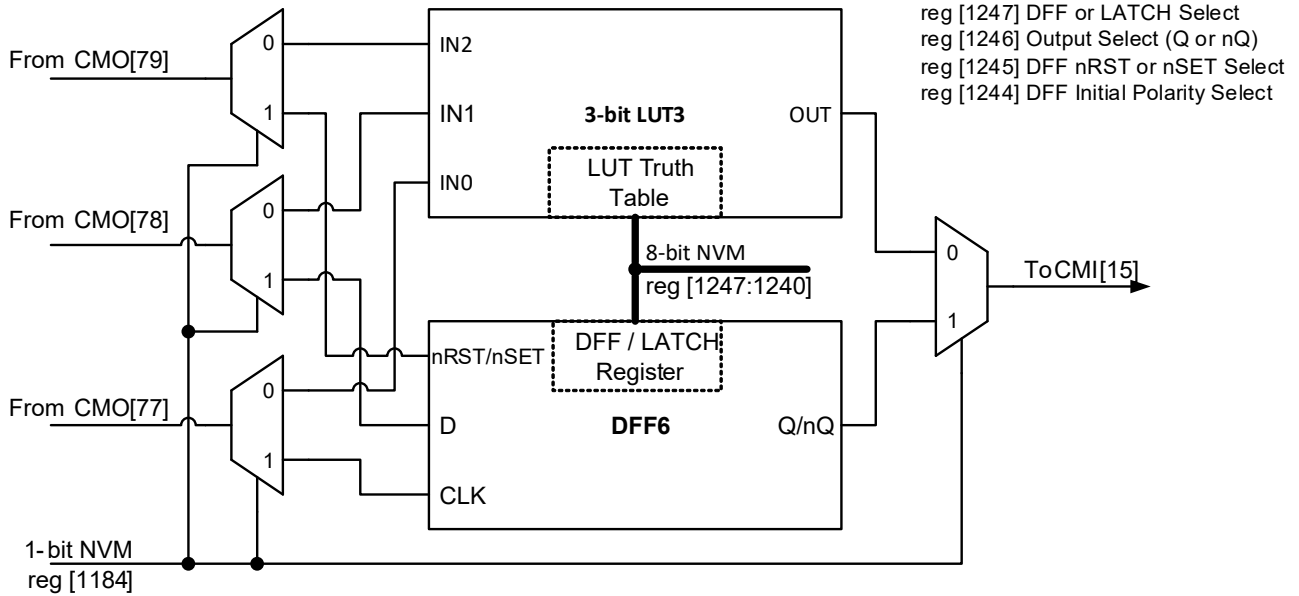

Figure 22. 3-bit LUT3 or DFF6 with RST/SET

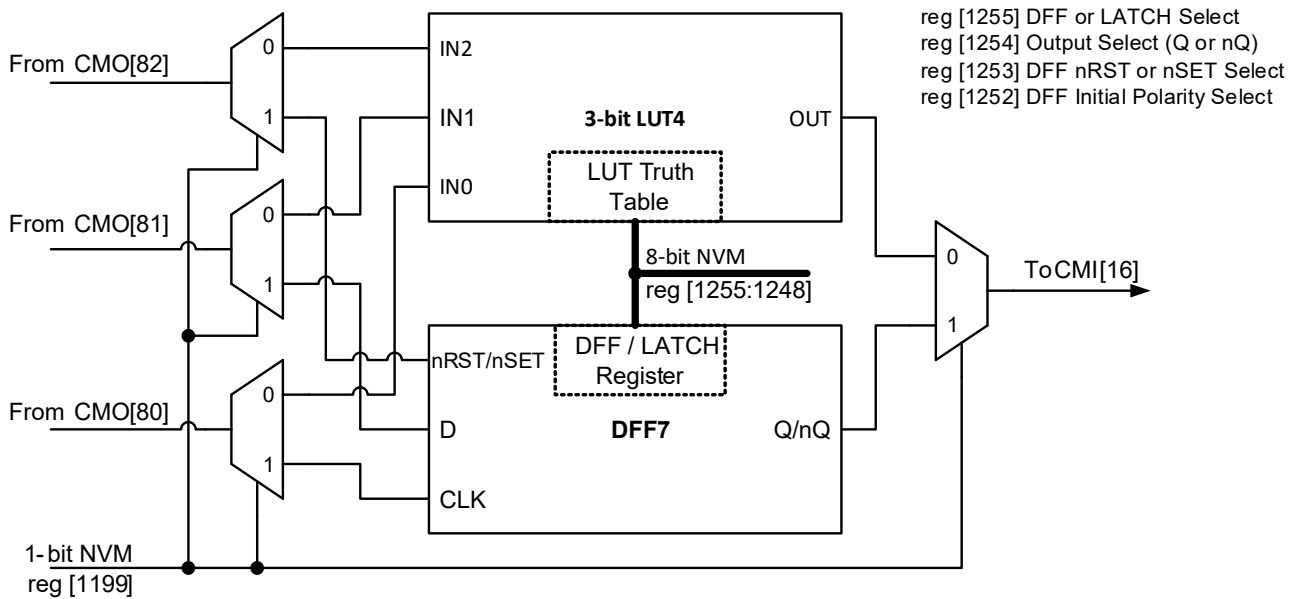

Figure 23. 3-bit LUT4 or DFF7 with RST/SET

6.2.1 3-Bit LUT or D Flip-Flop Macrocells Used as 3-Bit LUTs

Table 10. 3-bit LUT0 Truth Table

IN2	IN1	IN0	OUT	
0	0	0	reg [1216]	LSB
0	0	1	reg [1217]	
0	1	0	reg [1218]	
0	1	1	reg [1219]	
1	0	0	reg [1220]	
1	0	1	reg [1221]	
1	1	0	reg [1222]	
1	1	1	reg [1223]	MSB

Table 11. 3-bit LUT1 Truth Table

IN2	IN1	IN0	OUT	
0	0	0	reg [1224]	LSB
0	0	1	reg [1225]	
0	1	0	reg [1226]	
0	1	1	reg [1227]	
1	0	0	reg [1228]	
1	0	1	reg [1229]	
1	1	0	reg [1230]	
1	1	1	reg [1231]	MSB

Table 12. 3-bit LUT2 Truth Table

IN2	IN1	IN0	OUT	
0	0	0	reg [1232]	LSB
0	0	1	reg [1233]	
0	1	0	reg [1234]	
0	1	1	reg [1235]	
1	0	0	reg [1236]	
1	0	1	reg [1237]	
1	1	0	reg [1238]	
1	1	1	reg [1239]	MSB

Table 13. 3-bit LUT3 Truth Table

IN2	IN1	IN0	OUT	
0	0	0	reg [1240]	LSB
0	0	1	reg [1241]	
0	1	0	reg [1242]	
0	1	1	reg [1243]	
1	0	0	reg [1244]	
1	0	1	reg [1245]	
1	1	0	reg [1246]	
1	1	1	reg [1247]	MSB

Table 14. 3-bit LUT4 Truth Table

IN2	IN1	IN0	OUT	
0	0	0	reg [1248]	LSB
0	0	1	reg [1249]	
0	1	0	reg [1250]	
0	1	1	reg [1251]	
1	0	0	reg [1252]	
1	0	1	reg [1253]	
1	1	0	reg [1254]	
1	1	1	reg [1255]	MSB

Each macrocell, when programmed for a LUT function, uses an 8-bit register to define their output function:

- 3-bit LUT0 is defined by reg [1223:1216]
- 3-bit LUT1 is defined by reg [1231:1224]
- 3-bit LUT2 is defined by reg [1239:1232]
- 3-bit LUT3 is defined by reg [1247:1240]
- 3-bit LUT4 is defined by reg [1255:1248].

Table 15 shows the register bits for the standard digital logic devices (AND, NAND, OR, NOR, XOR, XNOR) that can be created within each of the six 3-bit LUT logic cells.

Table 15. 3-bit LUT Standard Digital Functions

Function	MSB							LSB
AND-3	1	0	0	0	0	0	0	0
NAND-3	0	1	1	1	1	1	1	1
OR-3	1	1	1	1	1	1	1	0
NOR-3	0	0	0	0	0	0	0	1
XOR-3	1	0	0	1	0	1	1	0
XNOR-3	0	1	1	0	1	0	0	1

6.2.2 Initial Polarity Operations

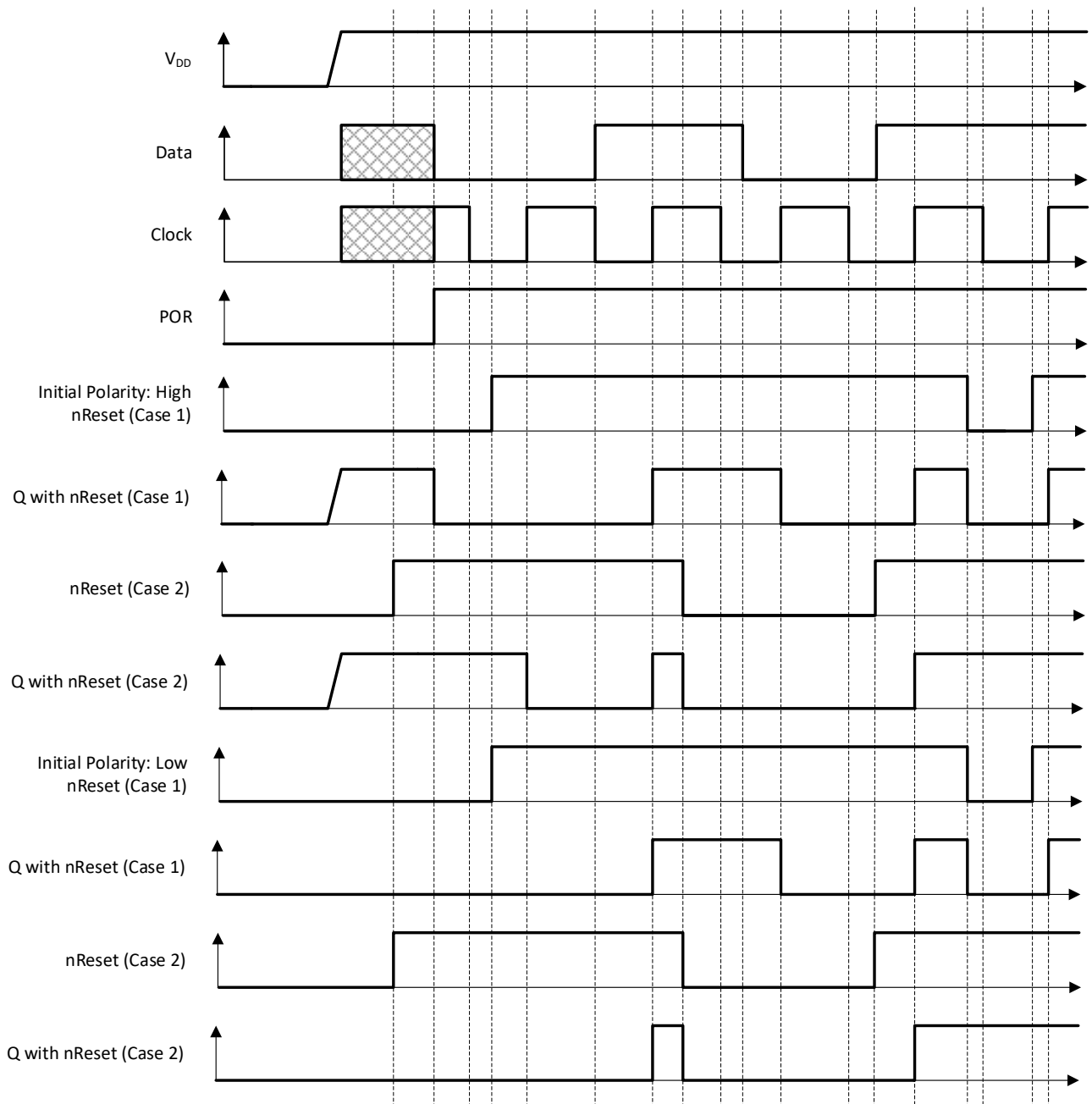

Figure 24. DFF Polarity Operations with nReset

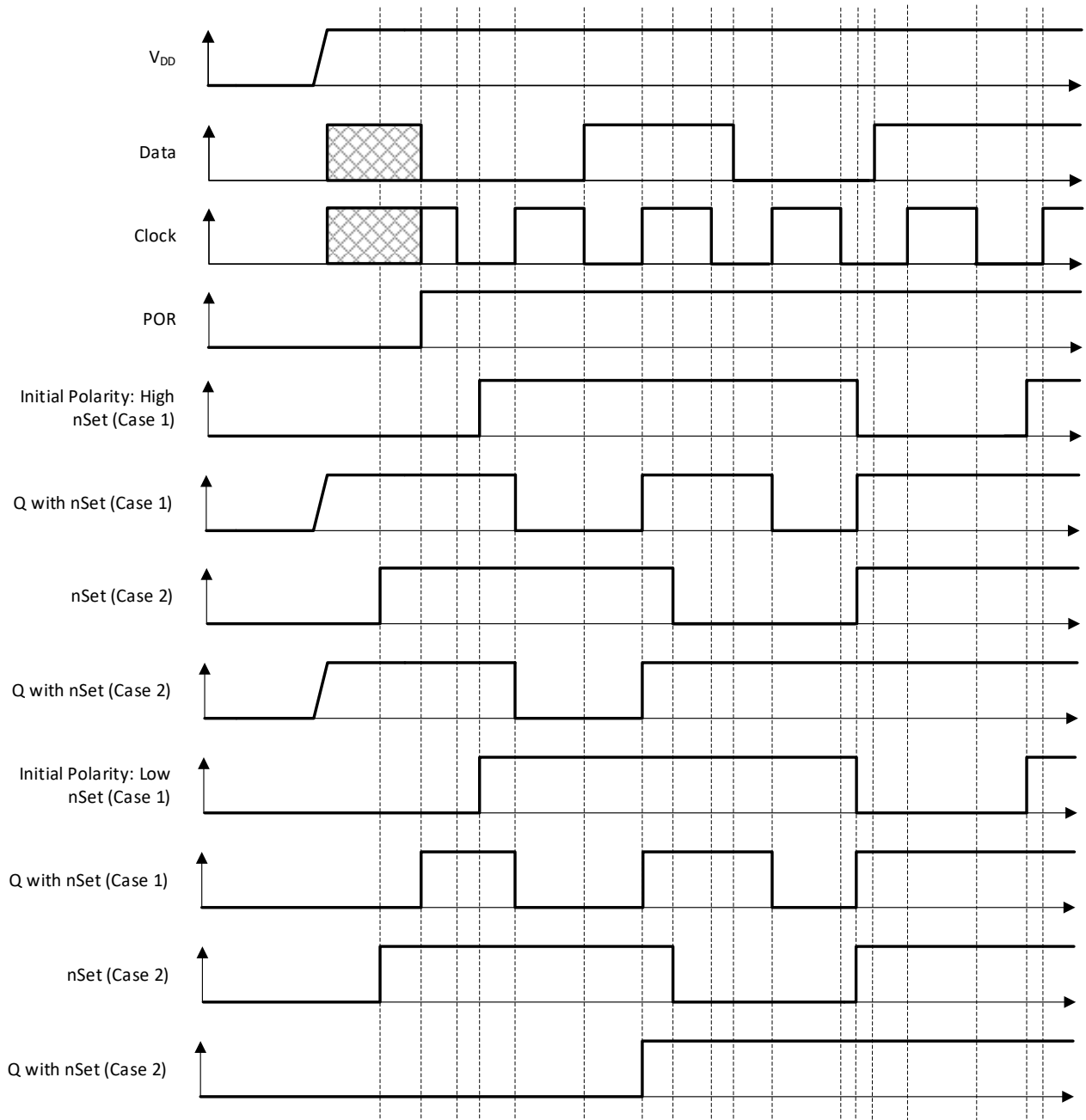

Figure 25. DFF Polarity Operations with nSet

6.3 3-Bit LUT or Pipe Delay Macrocell

There is one macrocell that can serve as either a 3-bit LUT or as a Pipe Delay.

When used to implement LUT functions, the 3-bit LUT takes in three input signals from the connection matrix and produces a single output, which goes back into the connection matrix.

When used as a Pipe Delay, there are three inputs signals from the matrix: Input (IN), Clock (CLK), and Reset (nRST). The Pipe Delay cell is built from 16 D Flip-Flop logic cells that provide the three delay options, two of which are user selectable. The DFF cells are tied in series where the output (Q) of each delay cell goes to the next DFF cell. The first delay option (OUT2) is fixed at the output of the first Flip-Flop stage. The other two outputs (OUT0 and OUT1) provide user selectable options for 1 to 16 stages of delay. There are delay output points for each set of the OUT0 and OUT1 outputs to a 16-input mux that is controlled by reg [1259:1256] for OUT0 and reg [1263:1260] for OUT1. The 16-input mux is used to select the amount of delay.

The overall time of the delay is based on the clock used in the SLG46540 design. Each DFF cell has a time delay of the inverse of the clock time (either external clock or the Oscillator within the SLG46540). The sum of the number of DFF cells used will be the total time delay of the Pipe Delay logic cell.

Note: CLK is rising edge triggered.

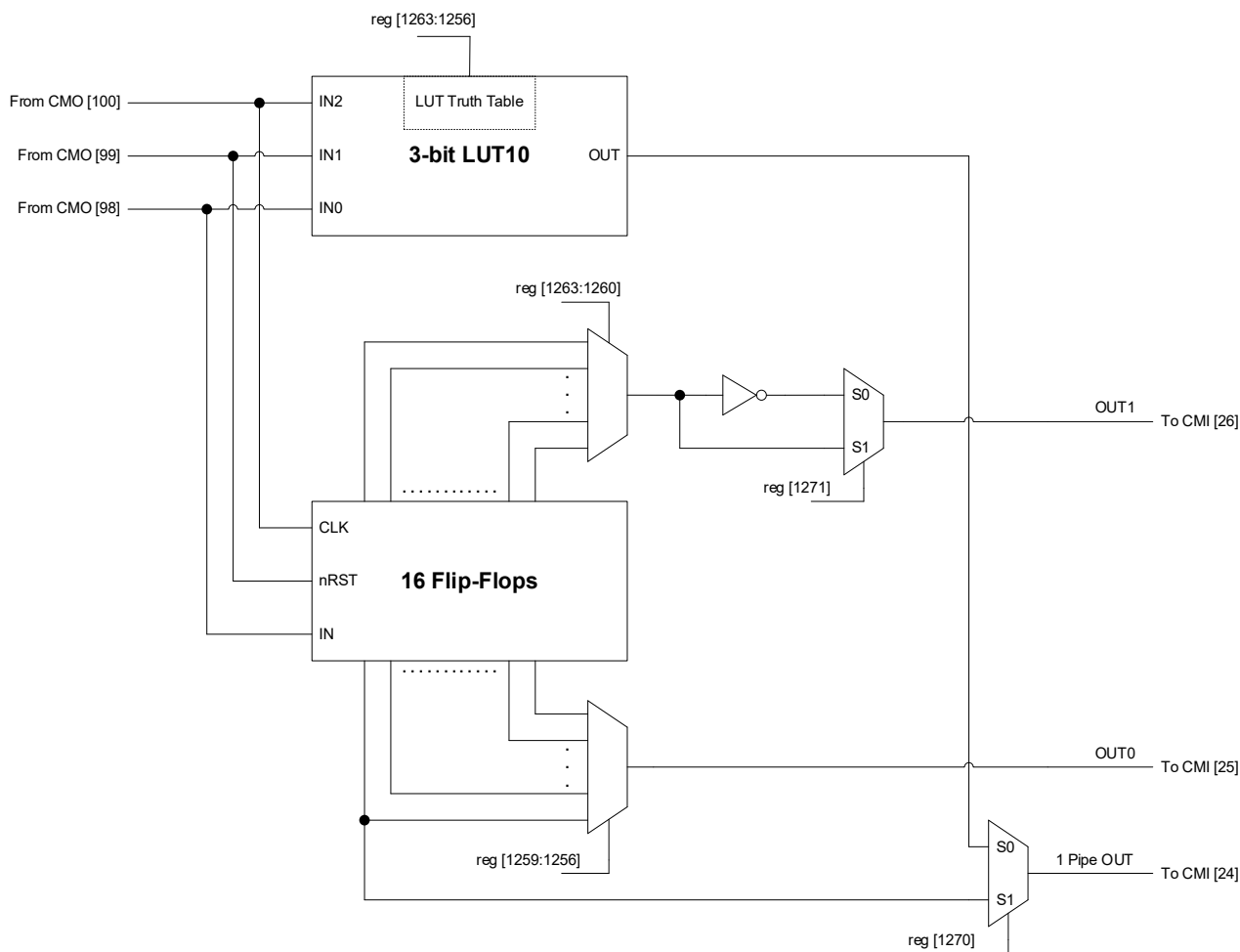

Figure 26. 3-bit LUT10 or Pipe Delay

6.3.1 3-Bit LUT or Pipe Delay Macrocell Used as 3-Bit LUT

Table 16. 3-bit LUT10 Truth Table

IN2	IN1	IN0	OUT	
0	0	0	reg [1256]	LSB
0	0	1	reg [1257]	
0	1	0	reg [1258]	
0	1	1	reg [1259]	
1	0	0	reg [1260]	
1	0	1	reg [1261]	
1	1	0	reg [1262]	
1	1	1	reg [1263]	MSB

Each macrocell, when programmed for a LUT function, uses an 8-bit register to define their output function:

- 3-Bit LUT10 is defined by reg [1263:1256].

6.4 3-Bit LUT or 8-Bit Counter/Delay Macrocells

There are five macrocells that can serve as either 3-bit LUTs or as Counter/Delays. When used to implement LUT function, the 3-bit LUT takes in three input signals from the connection matrix and produces a single output, which goes back into the connection matrix. When used to implement 8-Bit Counter/Delay function, two of the three input signals from the connection matrix go to the external clock (EXT_CLK) and reset (DLY_IN/CNT Reset) for the Counter/Delay, with the output going back to the connection matrix.

These macrocells can also operate in a one-shot mode, which will generate an output pulse of user-defined width.

These macrocells can also operate in a frequency detection or edge detection mode.

For timing diagrams refer to section 6.6 CNT/DLY/FSM Timing Diagrams.

Note: Counters initialize with counter data after POR.

Two of the five macrocells can have their active count value read via I²C (CNT4 and CNT6). See section 13.7.1 Reading Counter Data via I2C for further details.

6.4.1 3-Bit LUT or 8-Bit CNT/DLY Block Diagrams

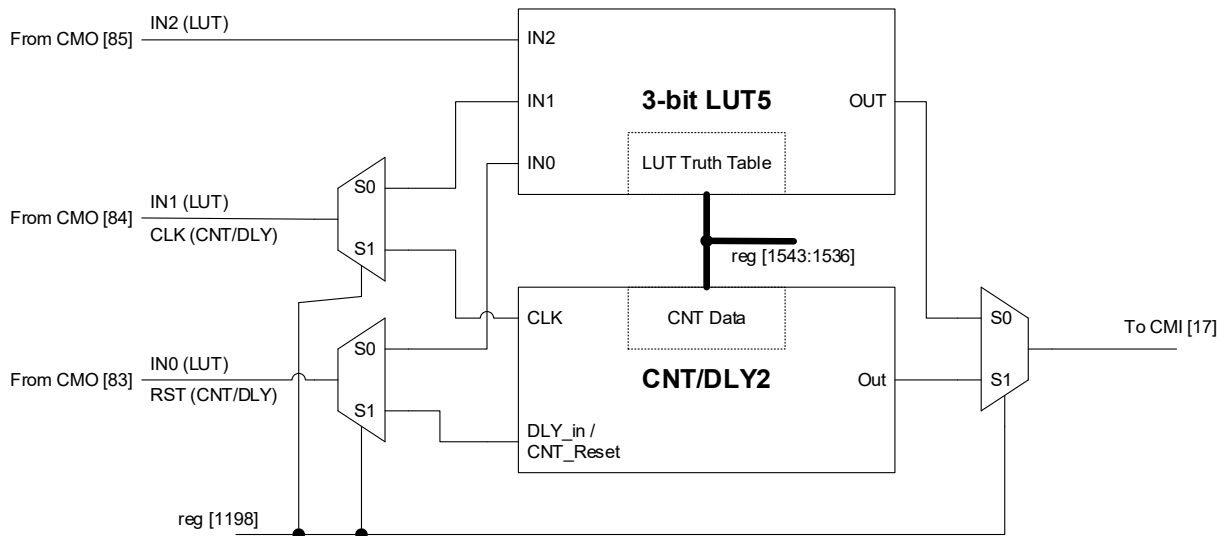

Figure 27. 3-bit LUT5 or CNT/DLY2

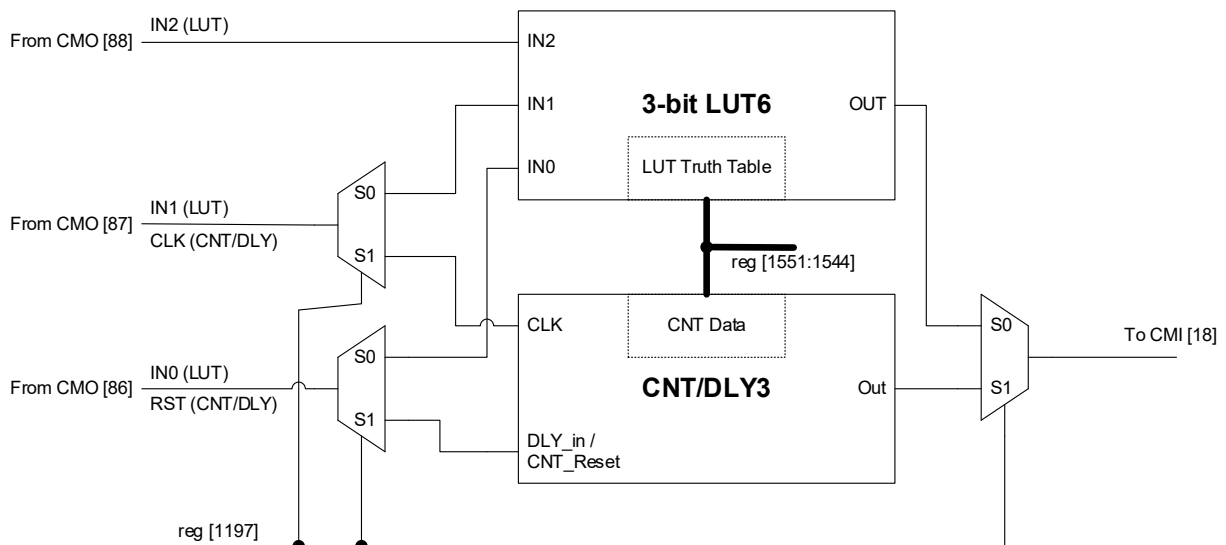

Figure 28. 3-bit LUT6 or CNT/DLY3

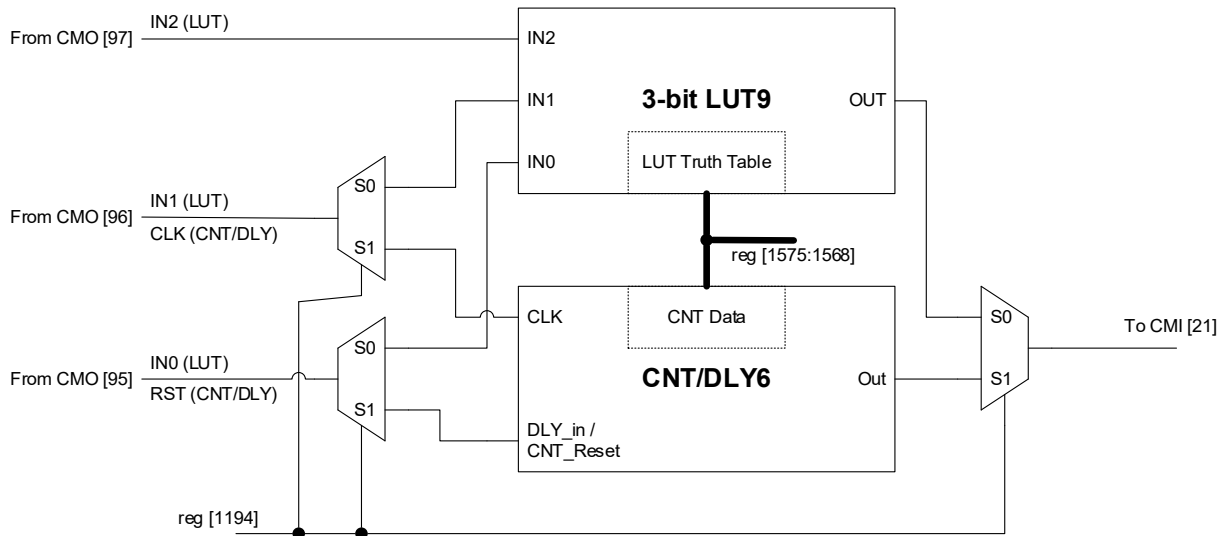

Figure 31. 3-bit LUT9 or CNT/DLY6

6.4.2 3-Bit LUT or Counter/Delay Macrocells Used as 3-Bit LUTs

Table 17. 3-bit LUT5 Truth Table

IN2	IN1	IN0	OUT	
0	0	0	reg [1536]	LSB
0	0	1	reg [1537]	
0	1	0	reg [1538]	
0	1	1	reg [1539]	
1	0	0	reg [1540]	
1	0	1	reg [1541]	
1	1	0	reg [1542]	
1	1	1	reg [1543]	MSB

Table 18. 3-bit LUT6 Truth Table

IN2	IN1	IN0	OUT	
0	0	0	reg [1544]	LSB
0	0	1	reg [1545]	
0	1	0	reg [1546]	
0	1	1	reg [1547]	
1	0	0	reg [1548]	
1	0	1	reg [1549]	
1	1	0	reg [1550]	
1	1	1	reg [1551]	MSB

Table 19. 3-bit LUT7 Truth Table

IN2	IN1	IN0	OUT	
0	0	0	reg [1552]	LSB
0	0	1	reg [1553]	
0	1	0	reg [1554]	
0	1	1	reg [1555]	
1	0	0	reg [1556]	
1	0	1	reg [1557]	
1	1	0	reg [1558]	
1	1	1	reg [1559]	MSB

Table 20. 3-bit LUT8 Truth Table

IN2	IN1	IN0	OUT	
0	0	0	reg [1560]	LSB
0	0	1	reg [1561]	
0	1	0	reg [1562]	
0	1	1	reg [1563]	
1	0	0	reg [1564]	
1	0	1	reg [1565]	
1	1	0	reg [1566]	
1	1	1	reg [1567]	MSB

Table 21. 3-bit LUT9 Truth Table

IN2	IN1	IN0	OUT	
0	0	0	reg [1568]	LSB
0	0	1	reg [1569]	
0	1	0	reg [1570]	
0	1	1	reg [1571]	
1	0	0	reg [1572]	
1	0	1	reg [1573]	
1	1	0	reg [1574]	
1	1	1	reg [1575]	MSB

Each macrocell, when programmed for a LUT function, uses an 8-bit register to define their output function:

- 3-bit LUT5 is defined by reg [1543:1536]
- 3-bit LUT6 is defined by reg [1551:1544]
- 3-bit LUT7 is defined by reg [1559:1552]
- 3-bit LUT8 is defined by reg [1567:1560]
- 3-bit LUT9 is defined by reg [1575:1568].

Table 22 shows the register bits for the standard digital logic.

Table 22. 3-bit LUT Standard Digital Functions

Function	MSB							LSB
AND-3	1	0	0	0	0	0	0	0
NAND-3	0	1	1	1	1	1	1	1
OR-3	1	1	1	1	1	1	1	0
NOR-3	0	0	0	0	0	0	0	1
XOR-3	1	0	0	1	0	1	1	0
XNOR-3	0	1	1	0	1	0	0	1

6.5 4-Bit LUT or 16-Bit Counter/Delay Macrocells

There are two macrocells that can serve as either 4-bit LUTs or as 16-bit Counter/Delays. When used to implement LUT function, the 4-bit LUT takes in four input signals from the Connection Matrix and produces a single output, which goes back into the Connection Matrix. When used to implement 16-Bit Counter/Delay function, four input signals from the connection matrix go to the external clock (EXT_CLK) and reset (DLY_IN/CNT_Reset), Keep and Up for the Counter/Delay, with the output going back to the connection matrix.

These two macrocells have an optional Finite State Machine (FSM) function. There are two matrix inputs for Up and Keep to support FSM functionality. Any counter within GreenPAK is counting down by default. In FSM mode (CNT/DLY0 and CNT/DLY1) it is possible to reverse counting by applying High level to Up input. Also, there is a possibility to pause counting by applying High level to Keep input, after the level goes Low, the counter will proceed counting. These macrocells can also operate in a one-shot mode, which will generate an output pulse of user-defined width.

These macrocells can also operate in a frequency detection.

Delay time and Output Period can be calculated using the following formulas:

- Delay time: $[(\text{Counter data} + 2)/\text{CLK input frequency} - \text{Offset (Note 1)}]$
- Output Period: $[(\text{Counter data} + 1)/\text{CLK input frequency} - \text{Offset (Note 1)}]$.

One Shot pulse width can be calculated using formula:

- Pulse width = $[(\text{Counter Data} + 2)/\text{CLK input frequency} - \text{Offset (Note 1)}]$.

Note 1: Offset is the asynchronous time offset between the input signal and the first clock pulse.

Note 2: Counters initialize with counter data after POR.

For timing diagrams refer to section [6.6 CNT/DLY/FSM Timing Diagrams](#).

Both of these macrocells can have their active count value read via I²C. See section [13.7.1 Reading Counter Data via I2C](#) for further details.

6.5.1 4-Bit LUT or 16-Bit CNT/DLY Block Diagram

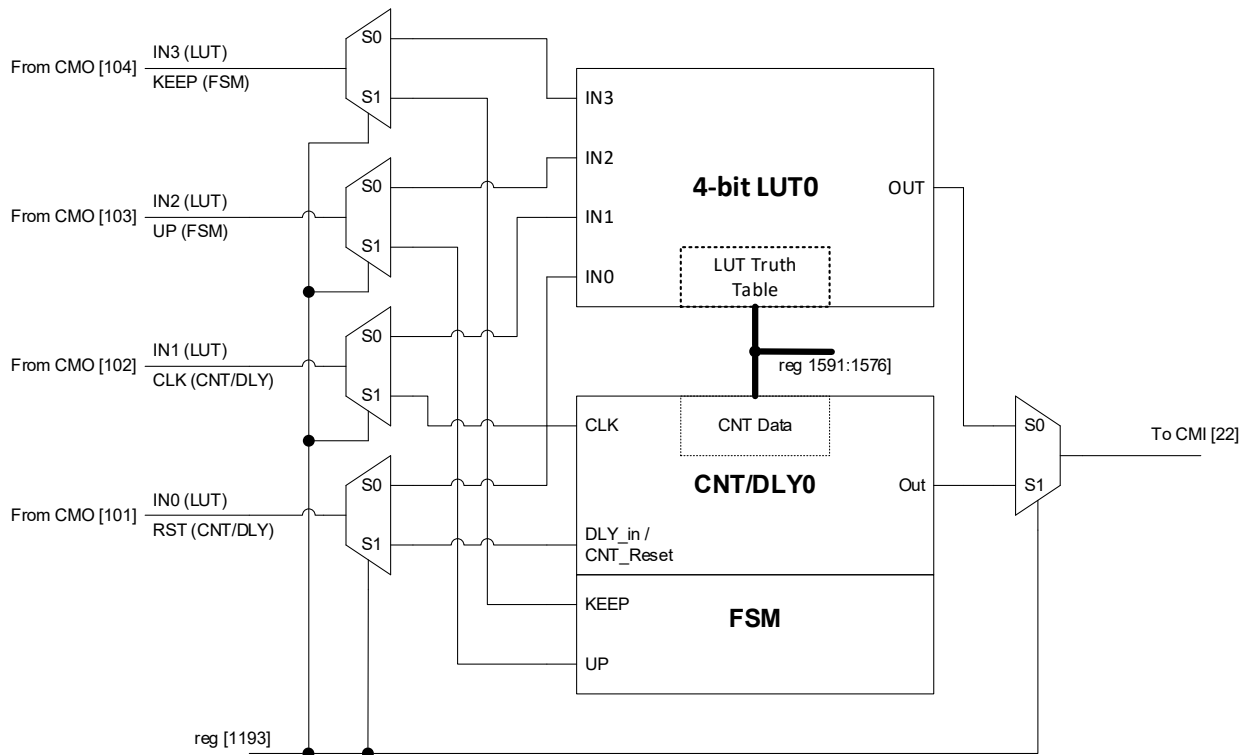

Figure 32. 4-bit LUT0 or CNT/DLY0

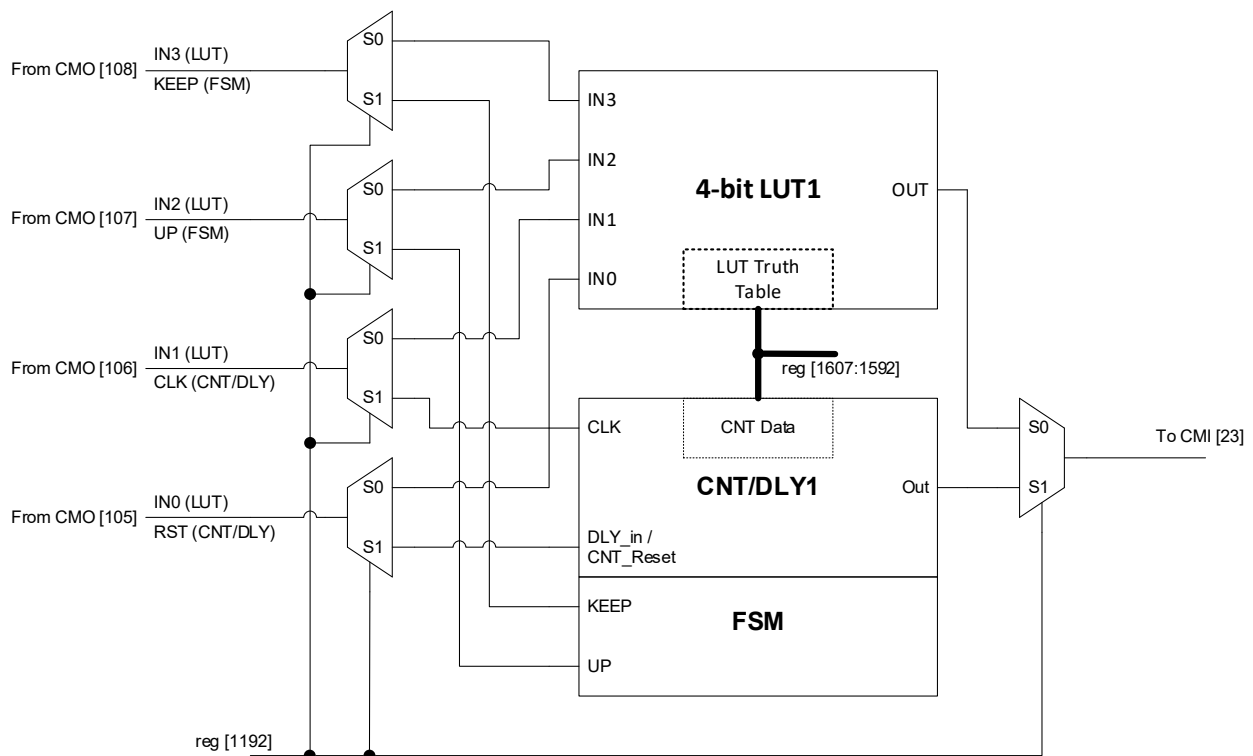

Figure 33. 4-bit LUT1 or CNT/DLY1

6.5.2 4-Bit LUT or 16-Bit Counter/Delay Macrocells Used as 4-Bit LUTs

Table 23. 4-bit LUT0 Truth Table

IN3	IN2	IN1	IN0	OUT	
0	0	0	0	reg [1576]	LSB
0	0	0	1	reg [1577]	
0	0	1	0	reg [1578]	
0	0	1	1	reg [1579]	
0	1	0	0	reg [1580]	
0	1	0	1	reg [1581]	
0	1	1	0	reg [1582]	
0	1	1	1	reg [1583]	
1	0	0	0	reg [1584]	
1	0	0	1	reg [1585]	
1	0	1	0	reg [1586]	
1	0	1	1	reg [1587]	
1	1	0	0	reg [1588]	
1	1	0	1	reg [1589]	
1	1	1	0	reg [1590]	
1	1	1	1	reg [1591]	MSB

Table 24. 4-bit LUT1 Truth Table

IN3	IN2	IN1	IN0	OUT	
0	0	0	0	reg [1592]	LSB
0	0	0	1	reg [1593]	
0	0	1	0	reg [1594]	
0	0	1	1	reg [1595]	
0	1	0	0	reg [1596]	
0	1	0	1	reg [1597]	
0	1	1	0	reg [1598]	
0	1	1	1	reg [1599]	
1	0	0	0	reg [1600]	
1	0	0	1	reg [1601]	
1	0	1	0	reg [1602]	
1	0	1	1	reg [1603]	
1	1	0	0	reg [1604]	
1	1	0	1	reg [1605]	
1	1	1	0	reg [1606]	
1	1	1	1	reg [1607]	MSB

Each macrocell, when programmed for a LUT function, uses a 16-bit register to define their output function:

- 4-bit LUT0 is defined by reg [1591:1576]
- 4-bit LUT1 is defined by reg [1607:1592].

Table 25. 4-bit LUT Standard Digital Functions

Function	MSB															LSB
AND-4	1	0	0	0	0	0	0	0	0	0	0	0	0	0	0	0
NAND-4	0	1	1	1	1	1	1	1	1	1	1	1	1	1	1	1
OR-4	1	1	1	1	1	1	1	1	1	1	1	1	1	1	1	0
NOR-4	0	0	0	0	0	0	0	0	0	0	0	0	0	0	0	1
XOR-4	0	1	1	0	1	0	0	1	1	0	0	1	0	0	1	0
XNOR-4	1	0	0	1	0	1	1	0	0	1	1	0	1	0	0	1

6.6 CNT/DLY/FSM Timing Diagrams

6.6.1 Delay Mode (Edge Select: Both, Counter Data: 3) CNT/DLY2 to CNT/DLY6

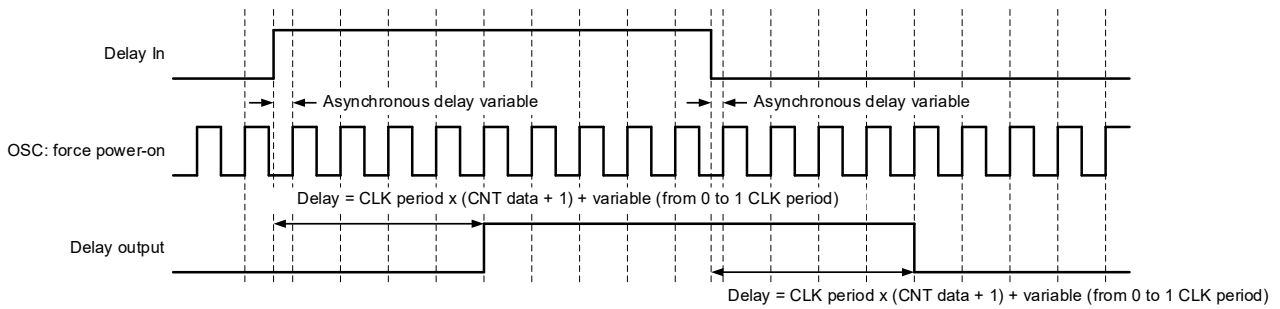

(Case 1) OSC: Forced Power-on (always running)

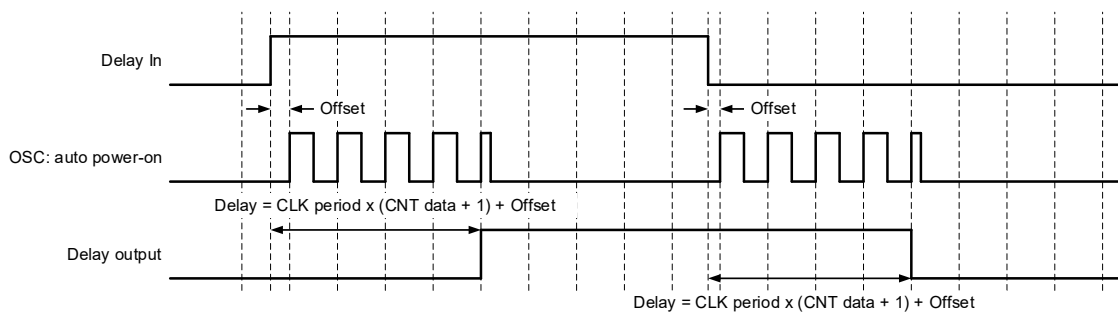

(Case 2) OSC: Auto Power-on (powers up from Delay In signal)

Figure 34. Delay Mode Timing Diagram

6.6.2 Count Mode (Count Data: 3), Counter Reset (Rising Edge Detect) CNT/DLY2 to CNT/DLY6

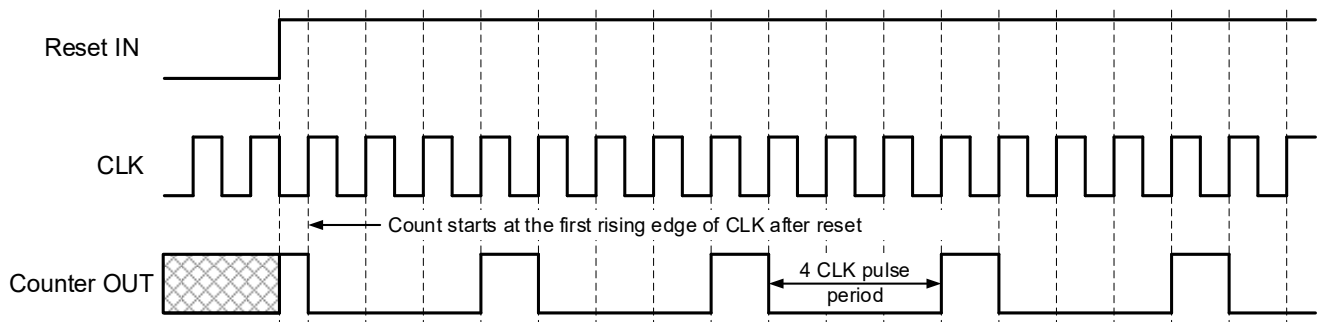

Figure 35. Counter Mode Timing Diagram

6.6.3 One-Shot Mode CNT/DLY0 to CNT/DLY6

This macrocell will generate a pulse whenever a selected edge is detected on its input. Register bits set the edge selection. The pulse width determines by counter data and clock selection properties. The output pulse polarity (non-inverted or inverted) is selected by register bit. Any incoming edges will be ignored during the pulse width generation. The following diagram shows one-shot function for non-inverted output.

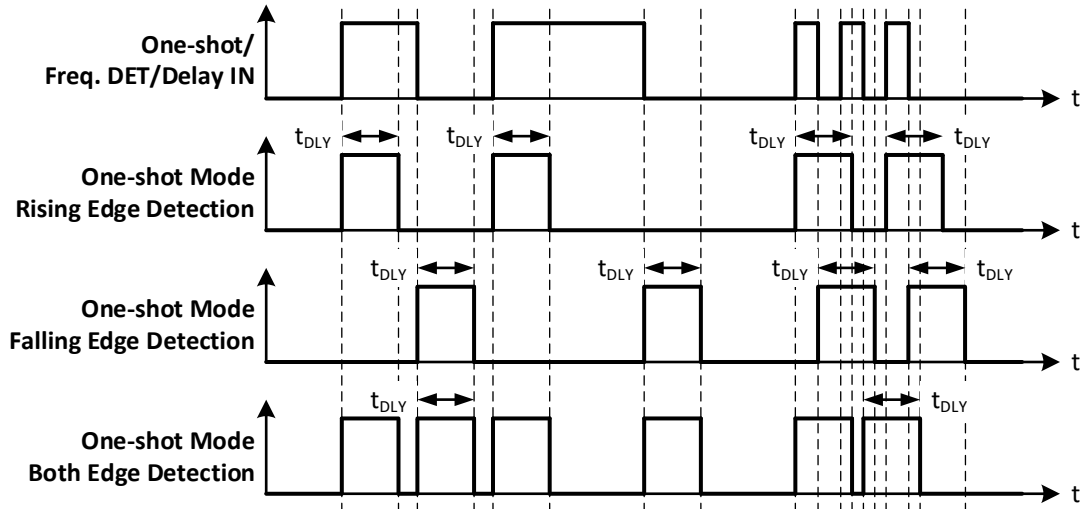

Figure 36. One-Shot Function Timing Diagram

This macrocell generates a high level pulse with a set width (defined by counter data) when detecting the respective edge. It does not restart while pulse is high.

6.6.4 Frequency Detection Mode CNT/DLY0 to CNT/DLY6

Rising Edge: The output goes high if the time between two successive edges is less than the delay. The output goes low if the second rising edge has not come after the last rising edge in specified time.

Falling Edge: The output goes high if the time between two falling edges is less than the set time. The output goes low if the second falling edge has not come after the last falling edge in specified time.

Both Edge: The output goes high if the time between the rising and falling edges is less than the set time, which is equivalent to the length of the pulse. The output goes low if after the last rising/falling edge and specified time, the second edge has not come.

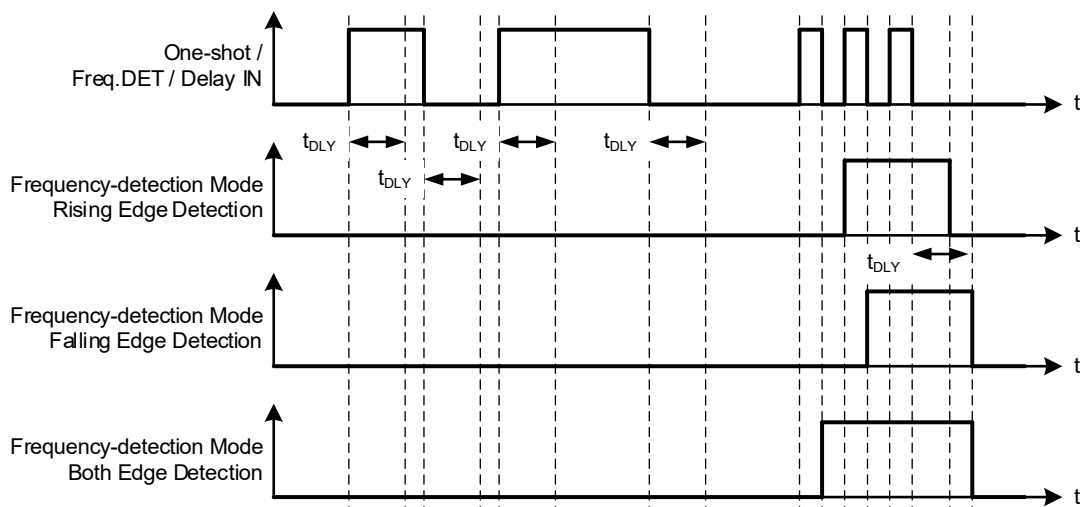

Figure 37. Frequency Detection Mode Timing Diagram

6.6.5 Edge Detection Mode CNT/DLY2 to CNT/DLY6

The macrocell generates high level short pulse when detecting the respective edge. See section 3.4.6 Programmable Delay Typical Delays and Widths.

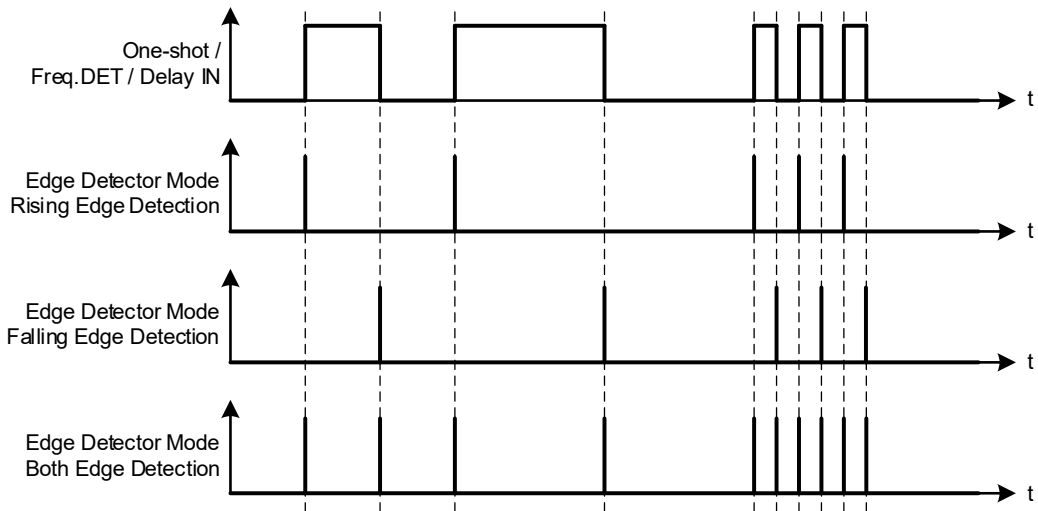

Figure 38. Edge Detection Mode Timing Diagram

6.6.6 Delay Mode CNT/DLY0 to CNT/DLY6

The macrocell shifts the respective edge to a set time and restarts by appropriate edge. It works as a filter if the input signal is shorter than the delay time.

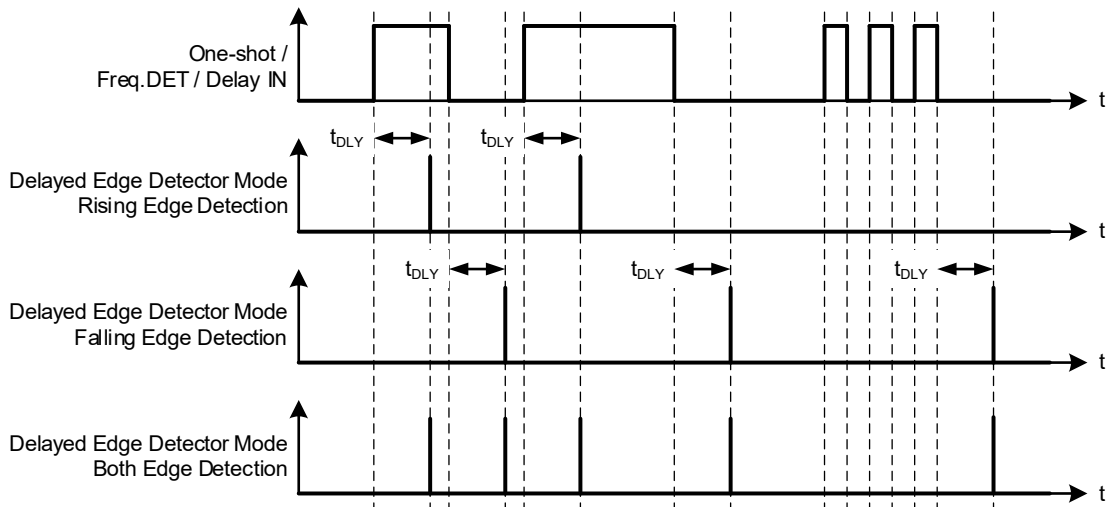

Figure 39. Delay Mode Timing Diagram

6.6.7 CNT/FSM Mode CNT/DLY0, CNT/DLY1

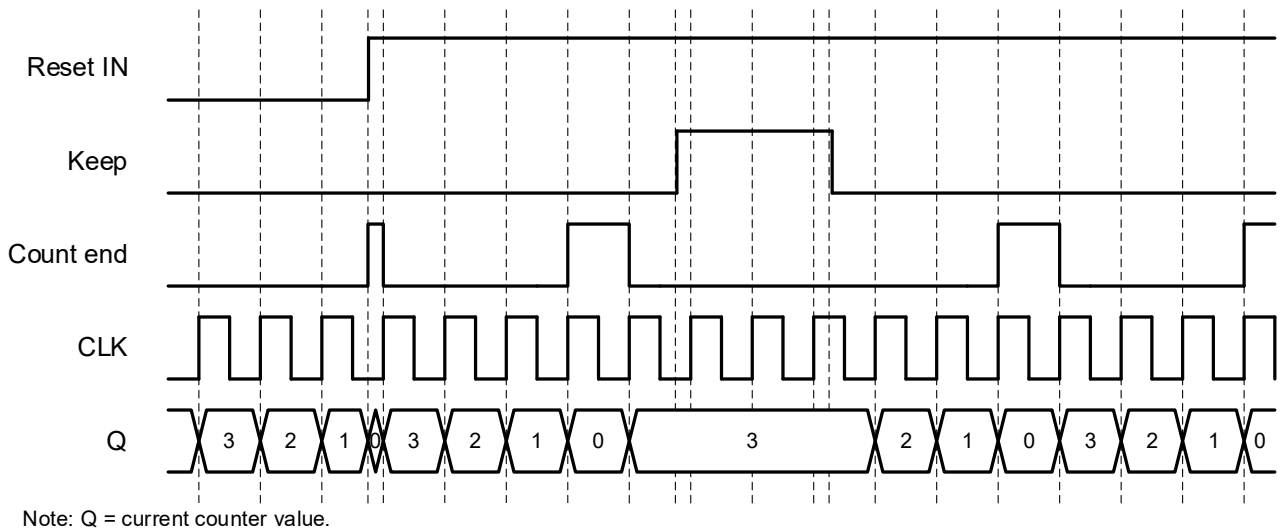

Figure 40. CNT/FSM Timing Diagram (Reset Rising Edge Mode, Oscillator is Forced On, UP = 0) for Counter Data = 3

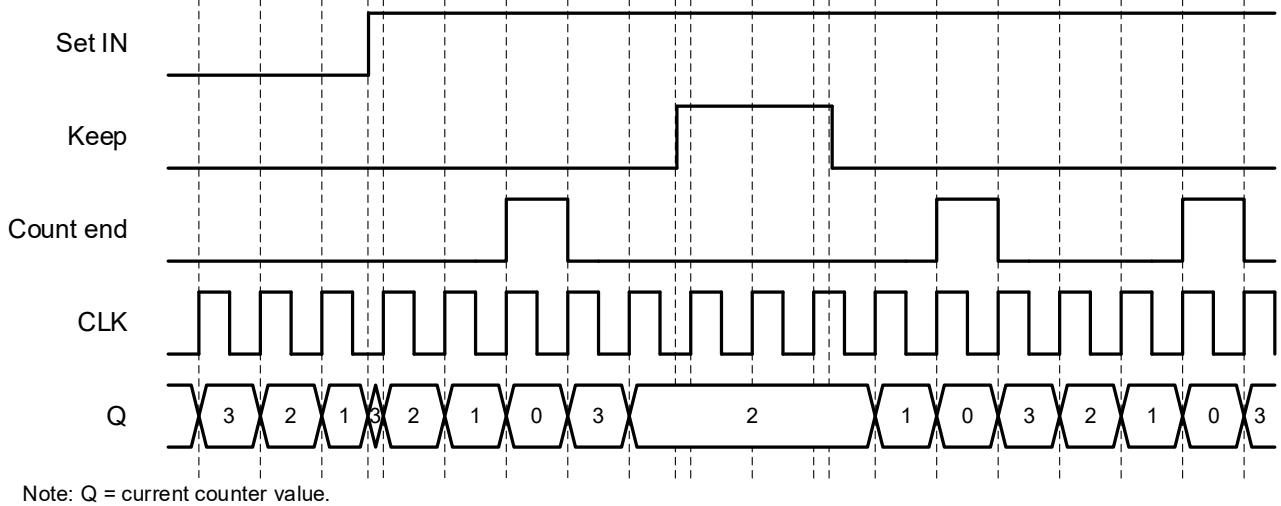

Figure 41. CNT/FSM Timing Diagram (Set Rising Edge Mode, Oscillator is Forced On, UP = 0) for Counter Data = 3

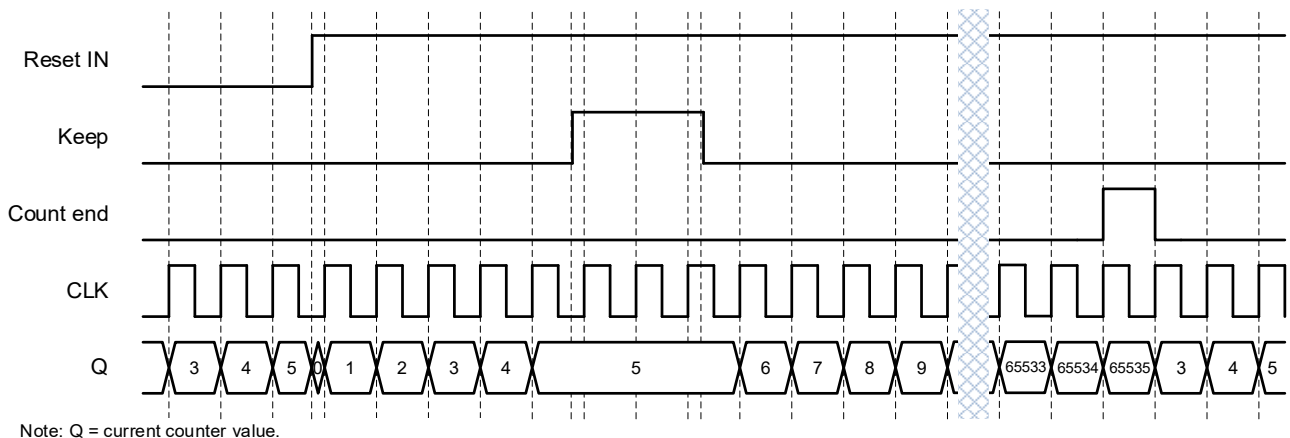

Figure 42. CNT/FSM Timing Diagram (Reset Rising Edge Mode, Oscillator is Forced On, UP = 1) for Counter Data = 3

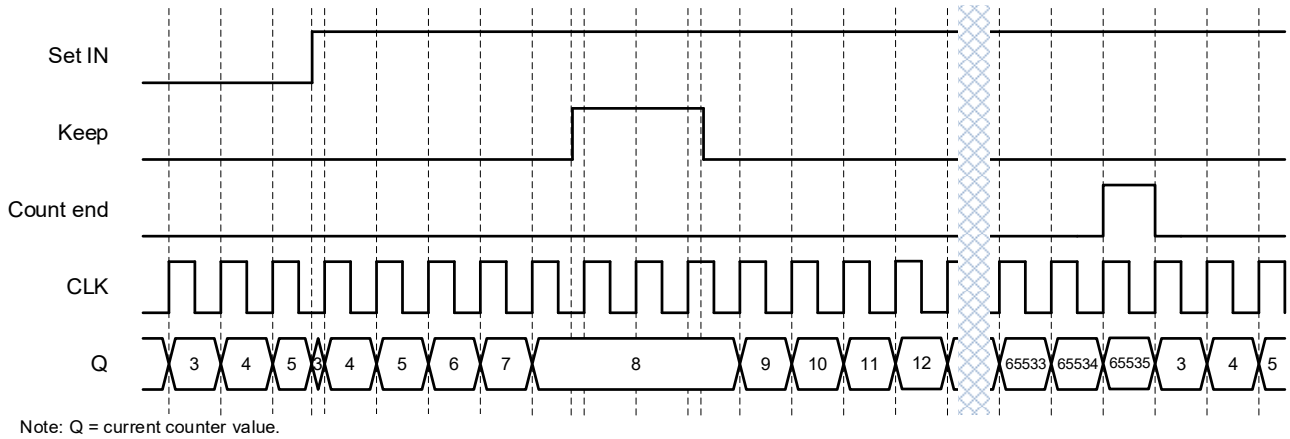

Figure 43. CNT/FSM Timing Diagram (Set Rising Edge Mode, Oscillator is Forced On, UP = 1) for Counter Data = 3

6.6.8 Difference in Counter Value for Counter, Delay, One-Shot, and Frequency Detect Modes

There is a difference in counter value for Counter and Delay/One-Shot/Frequency Detect modes. The counter value is shifted for two rising edges of the clock signal in Delay/One-Shot/Frequency Detect modes compared to Counter mode. See Figure 44.

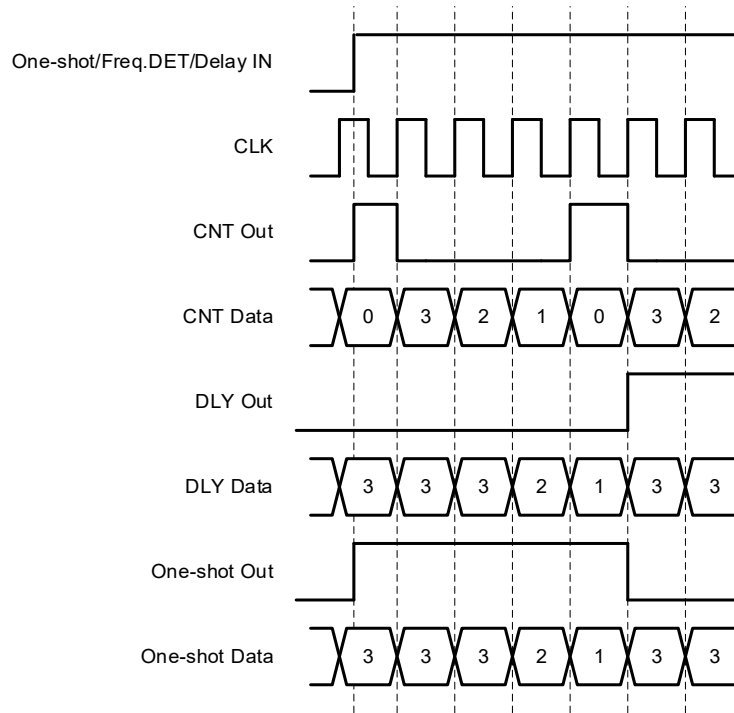

Figure 44. Counter Value, Counter Data = 3

6.7 2-bit LUT or Programmable Pattern Generator

The SLG46540 has one combination function macrocell that can serve as a logic or timing function. This macrocell can serve as a Look Up Table (LUT), or Programmable Pattern Generator (PGen).

When used to implement LUT functions, the 2-bit LUT takes in four input signals from the connection matrix and produces a single output, which goes back into the connection matrix. When used as a LUT to implement combinatorial logic functions, the outputs of the LUTs can be configured to any user defined function, including the following standard digital logic devices (AND, NAND, OR, NOR, XOR, XNOR). The user can also define the combinatorial relationship between inputs and outputs to be any selectable function.

When operating as a Programmable Pattern Generator, the output of the macrocell with clock out a sequence of two to sixteen bits that are user selectable in their bit values, and user selectable in the number of bits (up to sixteen) that are output before the pattern repeats. See Figure 46.

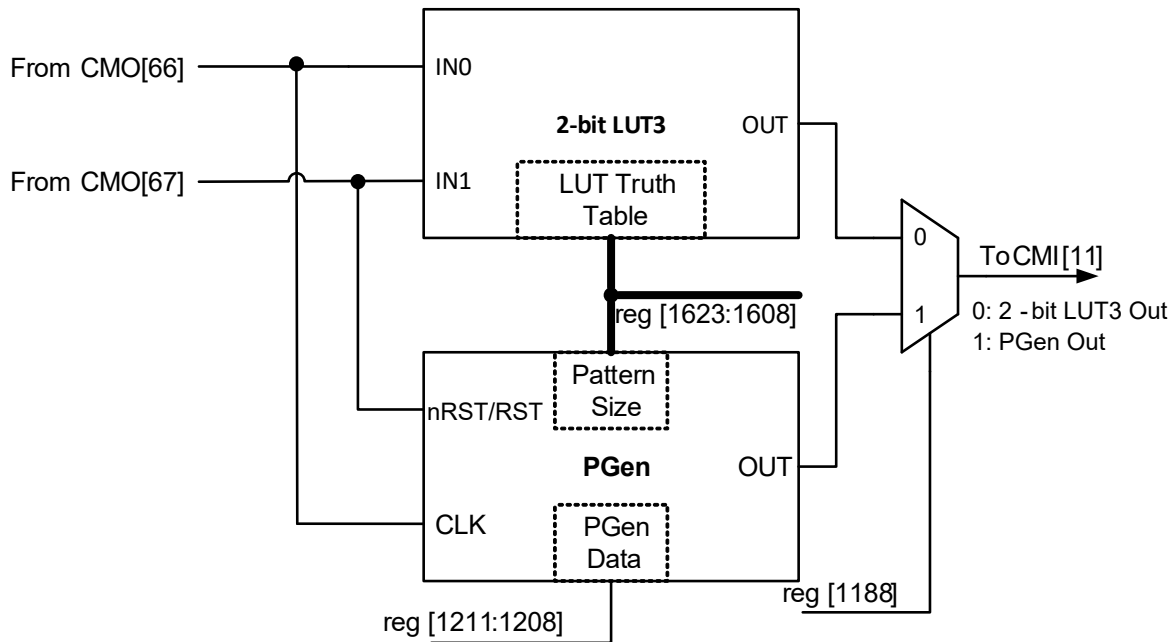

Figure 45. 2-bit LUT3 or PGen

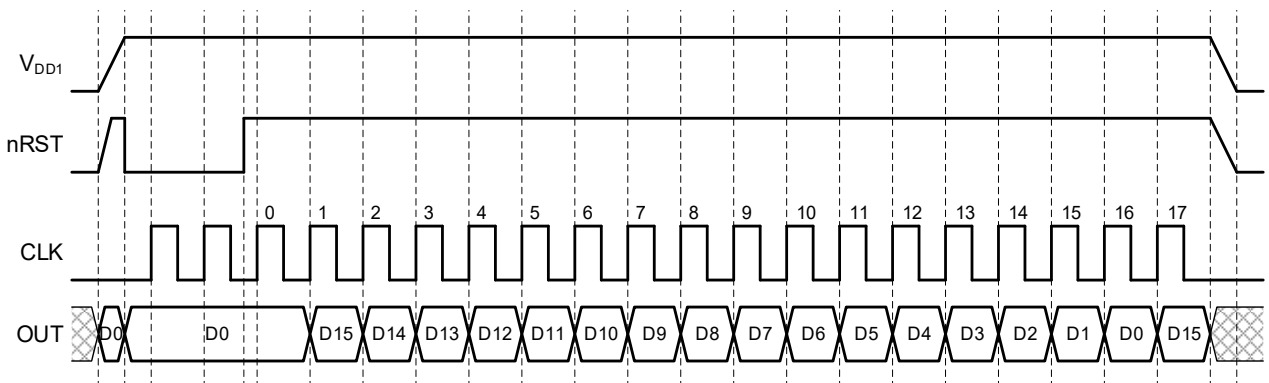

Figure 46. PGen Timing Diagram

6.8 Wake and Sleep Controller

The SLG46540 has a Wake and Sleep (WS) function for all ACMPs. The macrocell CNT/DLY0 can be reconfigured for this purpose $\text{reg [1319:1318]} = 11$ and $\text{reg [1495]} = 1$. The WS serves for power saving, it allows to switch on and off selected ACMPs on selected bit of 16-bit counter.

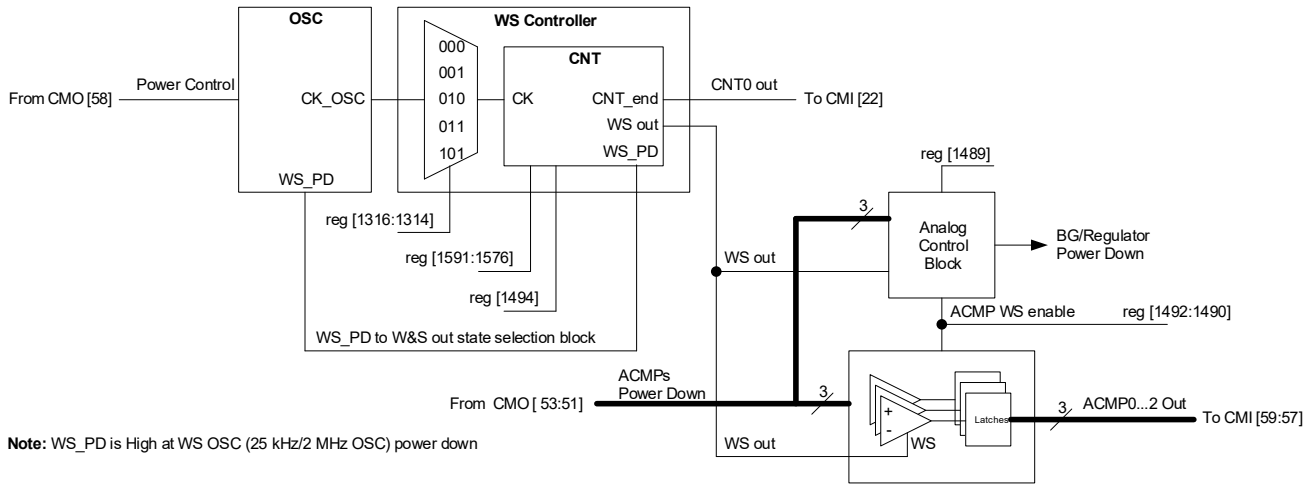

Figure 47. Wake/Sleep Controller

To use any ACMP under WS controller the following settings must be done:

- ACMP Power Up Input from matrix = 1 (for each ACMP separately)
- CNT/DLY0 must be set to Wake and Sleep Controller function (for all ACMPs)
- Register WS => enable (for each ACMP separately)
- CNT/DLY0 set/reset input = 0 (for all ACMPs)
- In case of using OSC1 (25 MHz), OSC0 must be set to Force Power-On.

As the OSC any oscillator with any pre-divider can be used. The user can select a period of time while the ACMPs are sleeping in a range of 1 - 65535 clock cycles. Before they are sent to sleep their outputs are latched, so the ACMPs remain their state (High or Low) while sleeping.

WS controller has the following settings:

- Wake and Sleep Output State (High/Low)
 - If OSC is powered off (Power-Down option is selected; power-down input = 1) and Wake and Sleep Output State = High, the ACMP is continuously on.
 - If OSC is powered off (Power-Down option is selected; power-down input = 1) and Wake and Sleep Output State = Low, the ACMP is continuously off.
 - Both cases WS function is turned off.
- Counter Data (Range: 1 - 65535)
 - User can select wake and sleep ratio of the ACMP; counter data = sleep time, one clock = wake time.
- Q mode - defines the state of WS counter data when Set/Reset signal appears
 - Reset - when active signal appears, the WS counter will reset to zero and High level signal on its output will turn the ACMPs on. When Reset signal goes out, the WS counter will go Low and turn the ACMPs off until the counter counts up to the end.
 - Set - when active signal appears, the WS counter will stop and Low level signal on its output will turn the ACMPs off. When Set signal goes out, the WS counter will go on counting and High level signal will turn the ACMPs on while counter is counting up to the end.
- Edge Select defines the edge for Q mode
 - High level Set/Reset - switches mode Set/Reset when level is High.
 - Note:** Q mode operates only in case of "High Level Set/Reset".
- Wake time selection - time required for wake signal to turn the ACMPs on
 - Normal Wake Time - when WS signal is High, it takes a BG time (100/550 μ s) to turn the ACMPs on. They will stay on until WS signal is Low again. Wake time is one clock period. It should be longer than BG turn on time and minimal required comparing time of the ACMP.
- Keep - pauses counting while Keep = 1

- Up - reverses counting
 - If Up = 1, CNT is counting up from user selected value to 65535.
 - If Up = 0, CNT is counting down from user selected value to 1.

7. Analog Comparators

There are three Analog Comparator (ACMP) macrocells in the SLG46540. In order for the ACMP cells to be used in a GreenPAK design, the power up signals (ACMPx_nPD) need to be active. By connecting to signals coming from the Connection Matrix, it is possible to have each ACMP be always on, always off, or power cycled based on a digital signal coming from the Connection Matrix. Also, all ACMPs have Wake and Sleep function (WS), see section [6.8 Wake and Sleep Controller](#). When ACMP is powered down, output is low.

PWR UP = 1 – ACMP is powered up.

PWR UP = 0 – ACMP is powered down.

During ACMP power up, its output will remain low, and then becomes valid 1 ms (max) after ACMP power up signal goes high, see [Figure 51](#). The ACMP cells have an input "Low bandwidth" signal selection, which can be used to save power and reduce noise impact when lower bandwidth signals are being compared. To ensure proper chip startup operation, it is recommended to enable the ACMPs with the POR signal, and not the VDD signal.

Note 1: Regulator and Charge Pump set to automatic ON/OFF.

Each of the ACMP cells has a positive input signal that can be provided by a variety of external sources. There is also a selectable gain stage (1x, 0.5x, 0.33x, 0.25x) before connection to the analog comparator. The Gain divider is unbuffered and consists of 250 k Ω (typ.) resistors. IN- voltage range: 0 V to 1.2 V. Can use V_{REF} selection $V_{DD}/4$ and $V_{DD}/3$ to maintain this input range.

Input bias current < 1 nA (typ.).

Each cell also has a hysteresis selection, to offer hysteresis of (0, 25, 50, 200) mV. The 50 mV and 200 mV hysteresis options can be used with internal voltage reference only, while 25 mV hysteresis option can be used with both internal and external voltage reference. The 50 mV and 200 mV hysteresis options are one way hysteresis. It means that the actual thresholds will be V_{REF} (high threshold) and $V_{REF} - \text{hysteresis}$ (low threshold). The ACMP output will retain its previous value, if the input voltage is within threshold window (between V_{REF} and $V_{REF} - \text{hysteresis}$). Please note: for the 25 mV hysteresis option threshold levels will be $V_{REF} + \text{hysteresis}/2$ (high threshold) and $V_{REF} - \text{hysteresis}/2$ (low threshold).

Note 2: Any ACMP powered on enables the Bandgap internal circuit as well. An analog voltage will appear on V_{REF} even when the Force Bandgap option is set as Disabled.

For high input impedance when using the gain divider (x0.25, x0.33, x0.5), it is possible to use the input buffer. However, this will add some offset, see [Figure 52](#) and [Figure 53](#). It is not recommended to use ACMP buffer when $V_{DD} < 2.5$ V.

7.1 ACMP0 Block Diagram

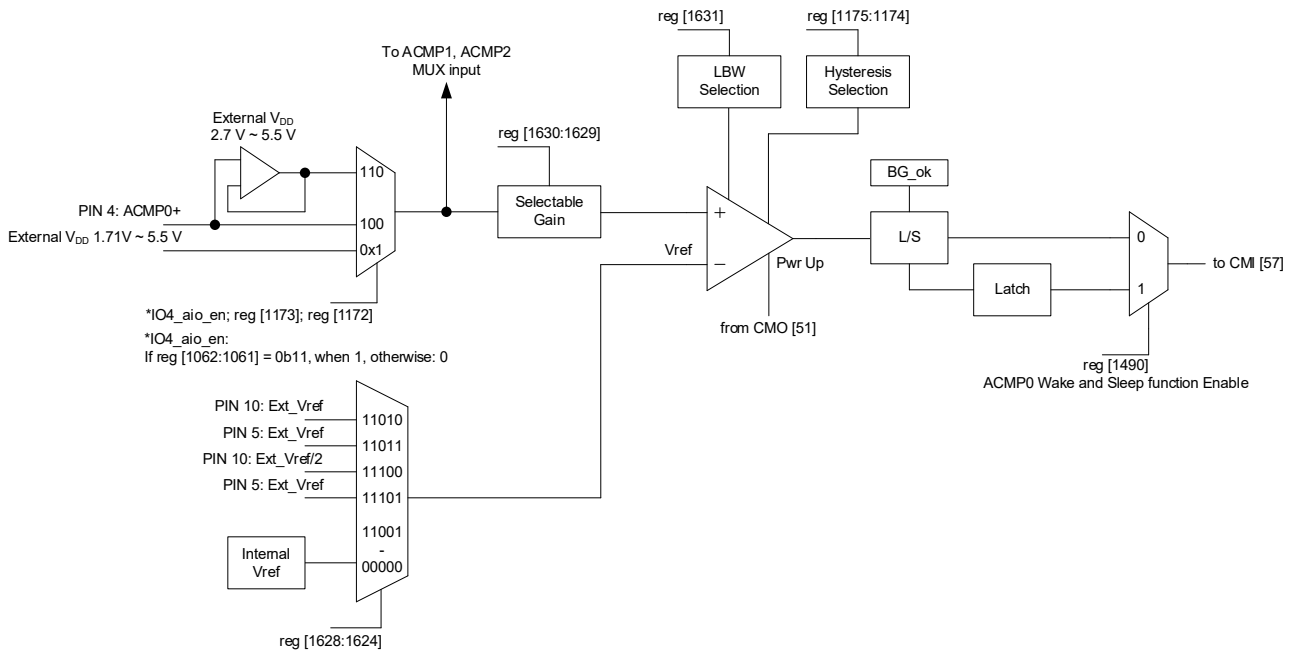
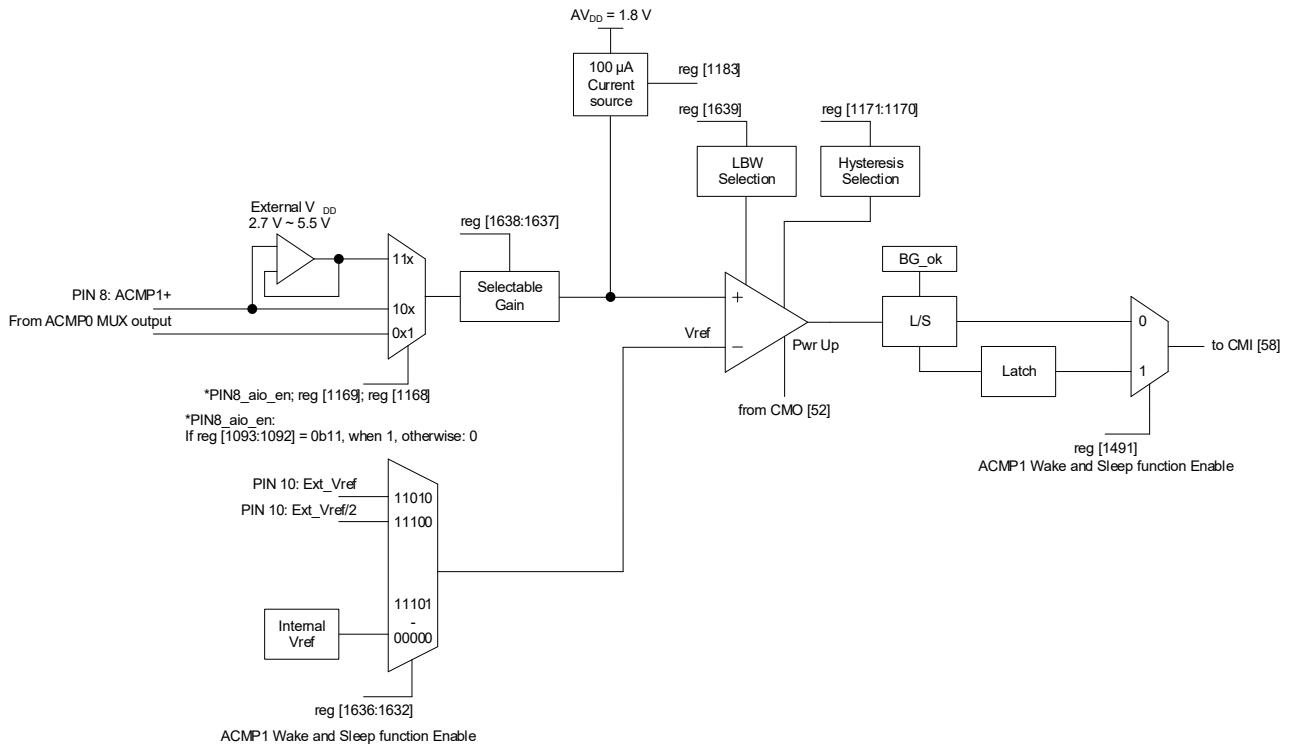

Figure 48. ACMP0 Block Diagram

7.2 ACMP1 Block Diagram



Note: when 100 μA Current Source is enabled input voltage on Pin 8 should not exceed 1.8 V.

Figure 49. ACMP1 Block Diagram

7.3 ACMP2 Block Diagram

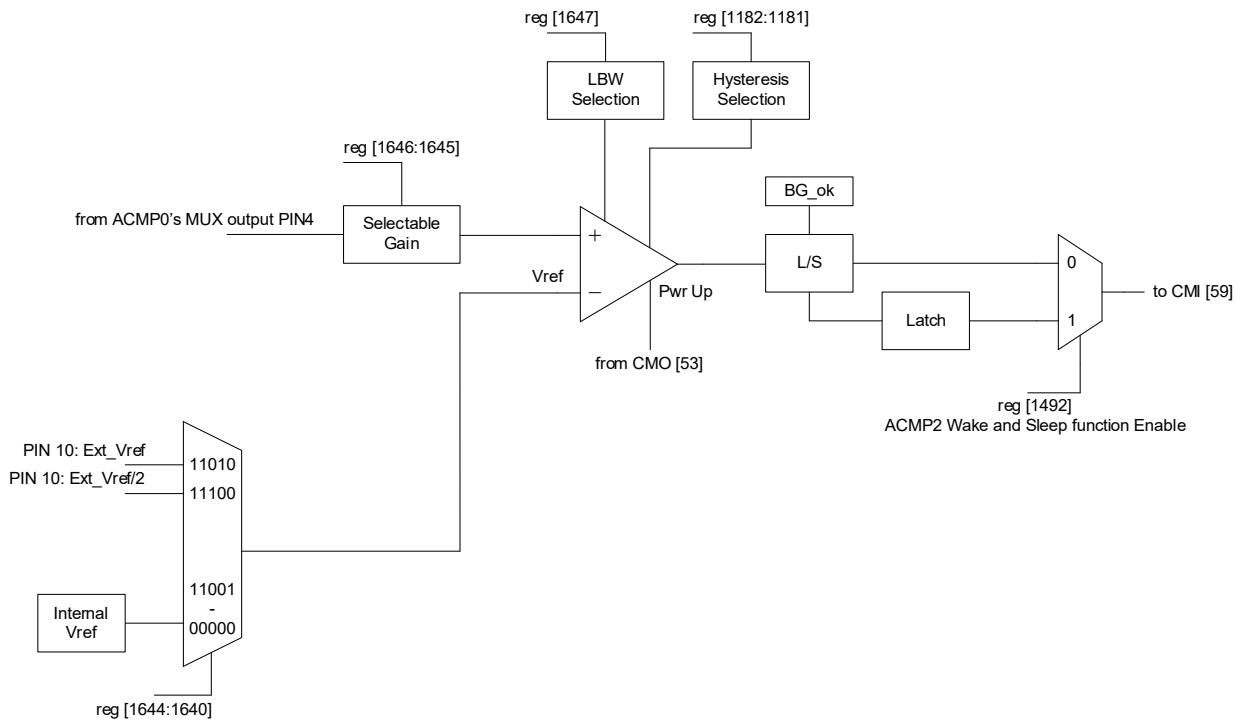

Figure 50. ACMP2 Block Diagram

7.4 ACMP Typical Performance

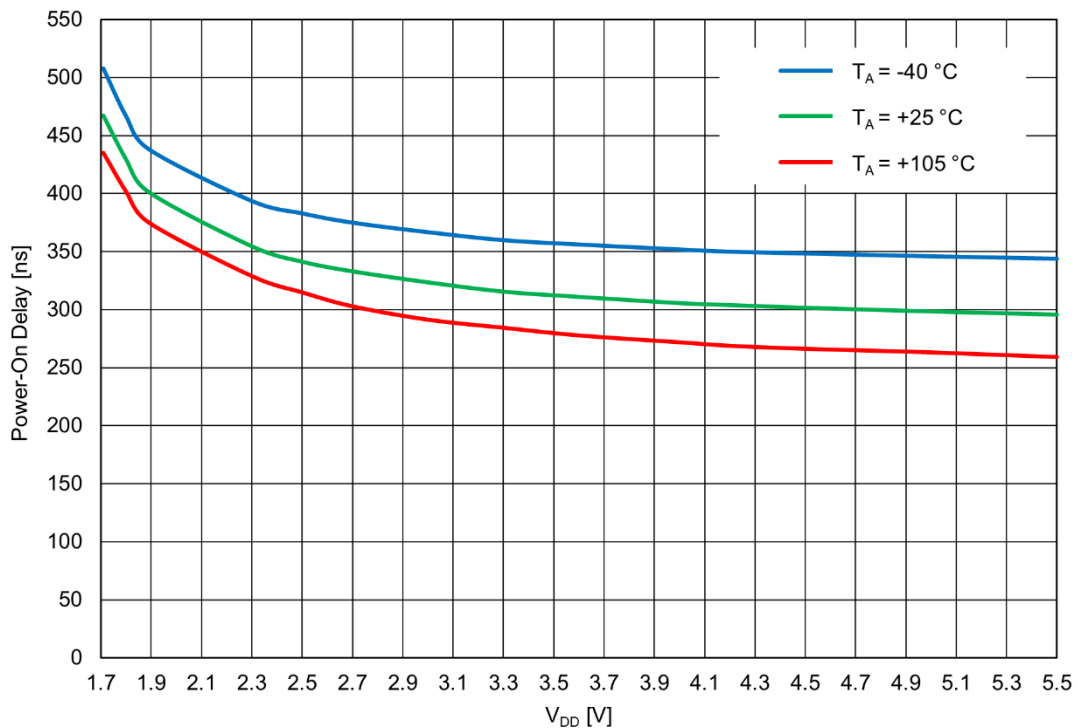

Figure 51. ACMPx Power-On Delay vs. V_{DD}, BG Delay – Any

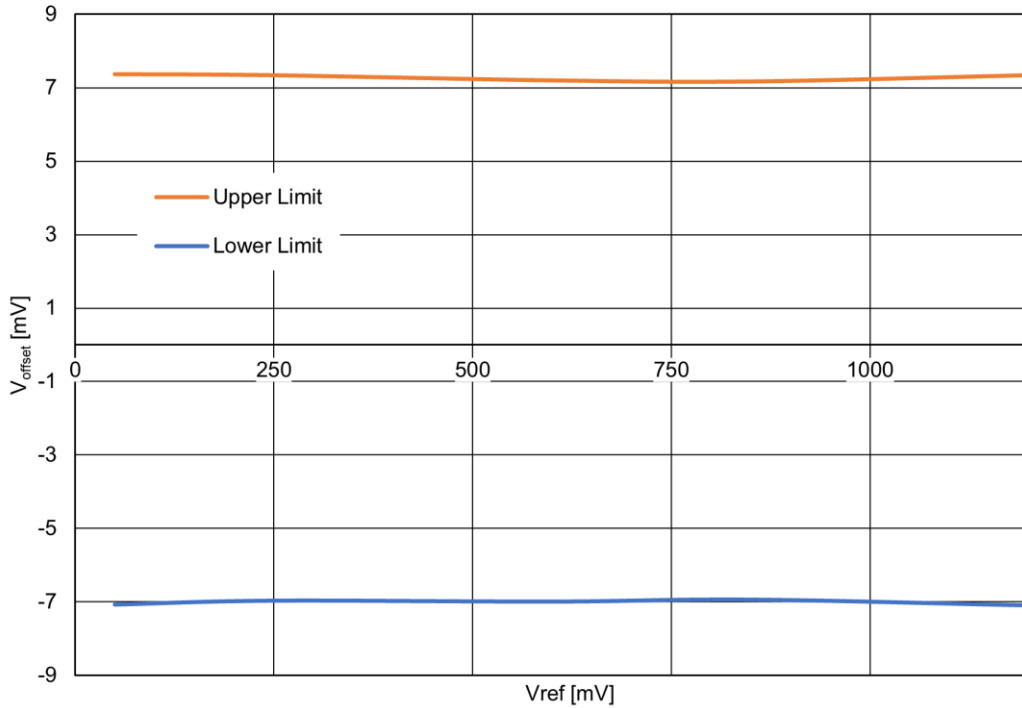

Figure 52. ACMPx Input Offset Voltage vs. V_{REF} at V_{DD} = 1.71 V to 5.5 V, T_A = -40 °C to +85 °C

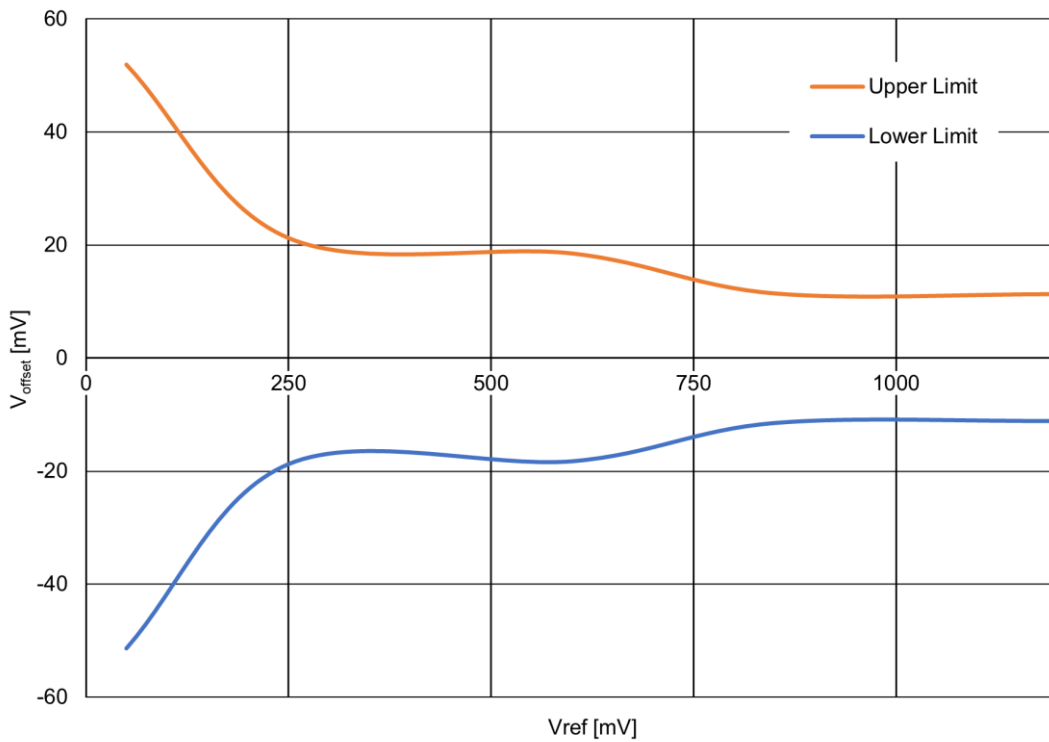

Figure 53. ACMPx Buffer Input Offset Voltage vs. V_{REF} at V_{DD} = 1.71 V to 5.5 V, T_A = -40 °C to +85 °C

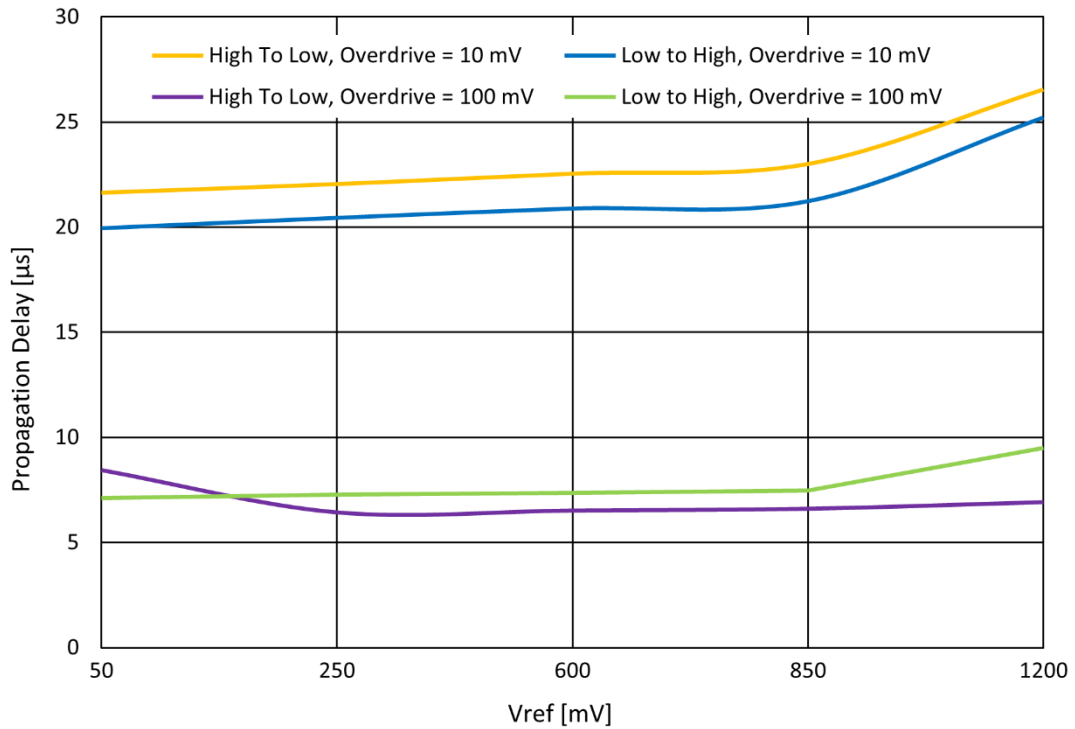

Figure 54. ACMPx Typical Propagation Delay at $T_A = +25\text{ }^\circ\text{C}$, Gain = 1, Hysteresis = 0, $V_{DD} = 1.71\text{ V}$ to 5.5 V , LPF-Enable

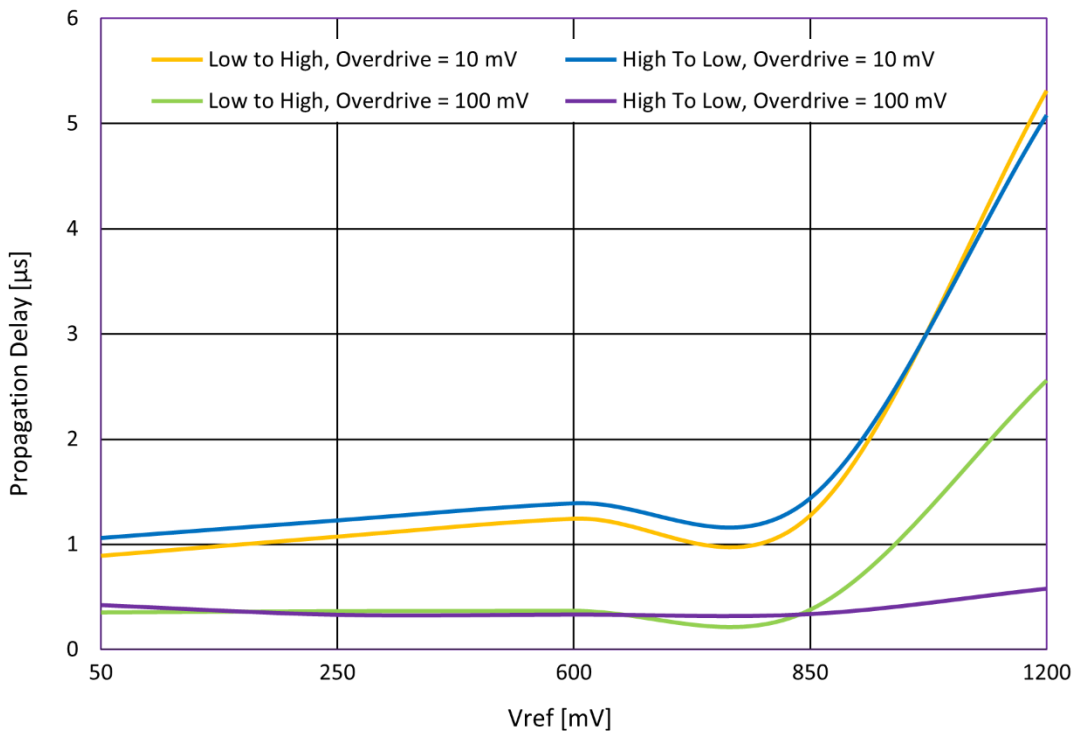

Figure 55. ACMPx Typical Propagation Delay at $T_A = +25\text{ }^\circ\text{C}$, Gain = 1, Hysteresis = 0, $V_{DD} = 1.71\text{ V}$ to 5.5 V , LPF-Disable

Note: When $V_{DD} < 1.8\text{ V}$ voltage reference should not exceed 1100 mV.

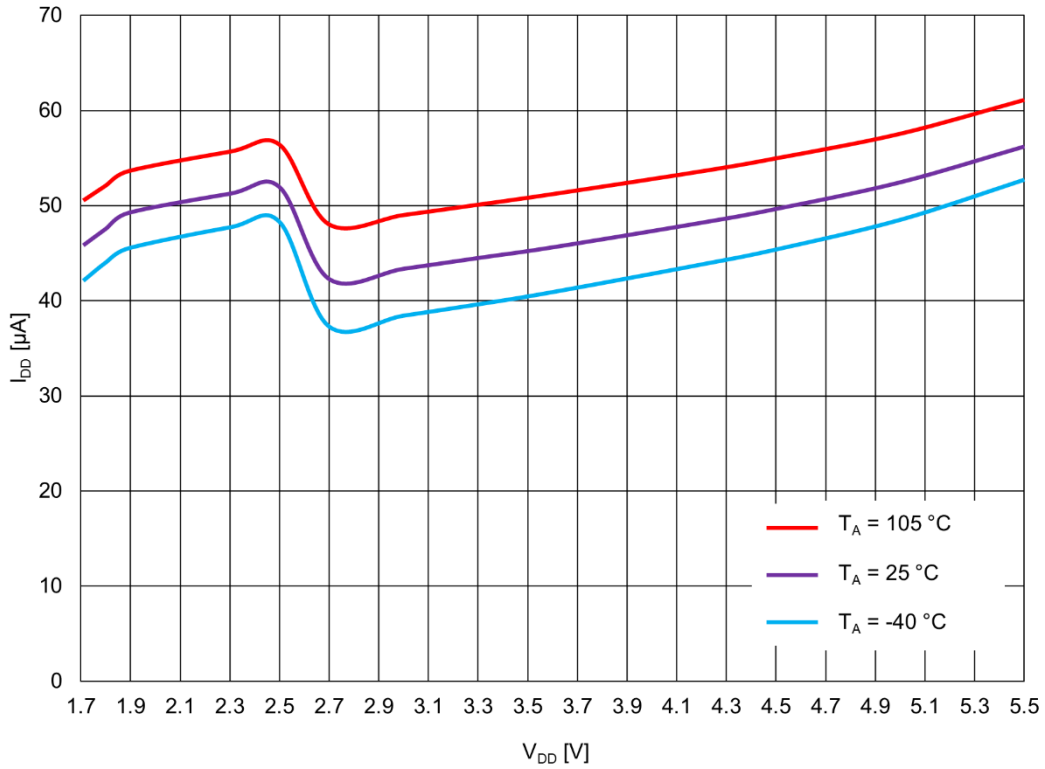

Figure 56. ACMPx Current Consumption vs. V_{DD} at V_{IN+} Connected to V_{DD}, Internal V_{REF} = 50 mV

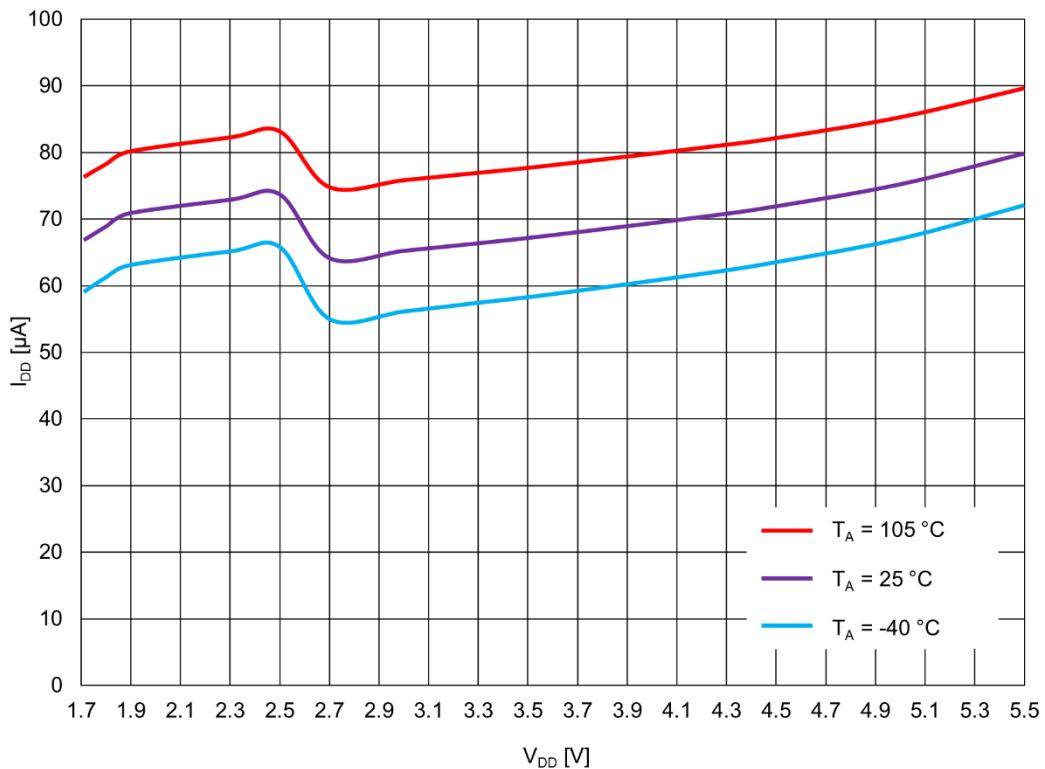

Figure 57. Buffered ACMPx Current Consumption vs. V_{DD} at V_{IN+} Connected to V_{DD}, Internal V_{REF} = 50 mV

8. Programmable Delay/Edge Detector

The SLG46540 has a programmable time delay logic cell available, that can generate a delay, that is selectable from one of four timings configured in the GreenPAK Designer. The programmable time delay cell can generate one of four different delay patterns, rising edge detection, falling edge detection, both edge detection, and both edge delay. See [Figure 58](#) and [Figure 59](#) for further information.

Note: The input signal must be longer than the delay, otherwise it will be filtered out.

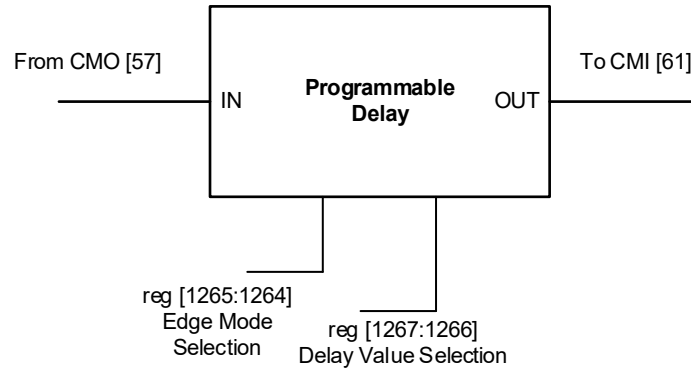
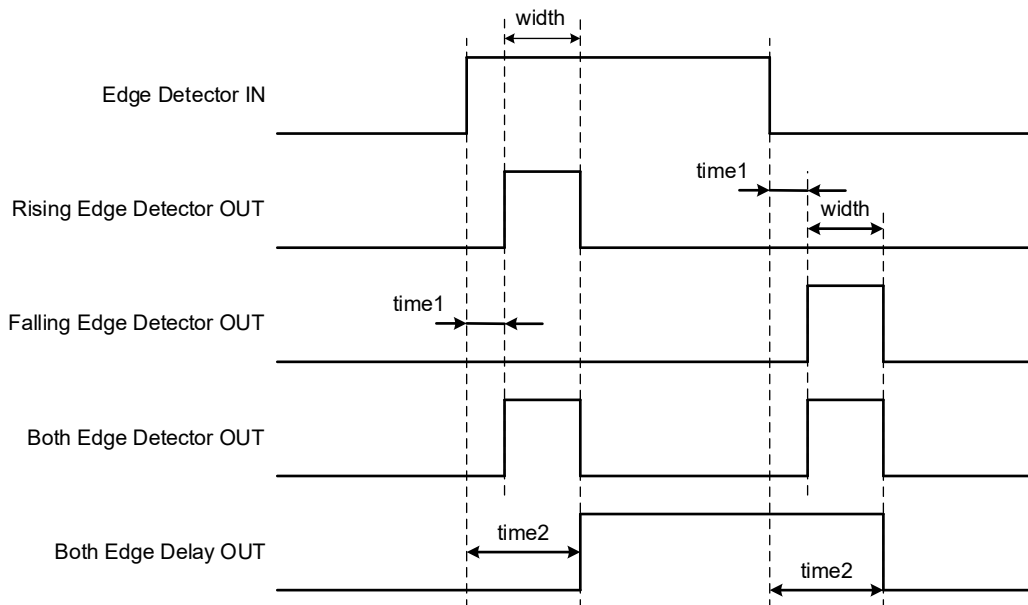

Figure 58. Programmable Delay

8.1 Programmable Delay Timing Diagram - Edge Detector Output



Note: time1 is a fixed value, time2 delay value is selected via register.

Figure 59. Edge Detector Output

Please refer to [3.4.5 Programmable Delay Typical Delays and Widths](#).

9. Additional Logic Function. Deglitch Filter

The SLG46540 has three additional logic functions that are connected directly to the Connection Matrix inputs and outputs. There are two deglitch filters, each with edge detector functions. See section 3.4.6 [Typical Filter Rejection Pulse Width](#).

9.1 Deglitch Filter/Edge Detector

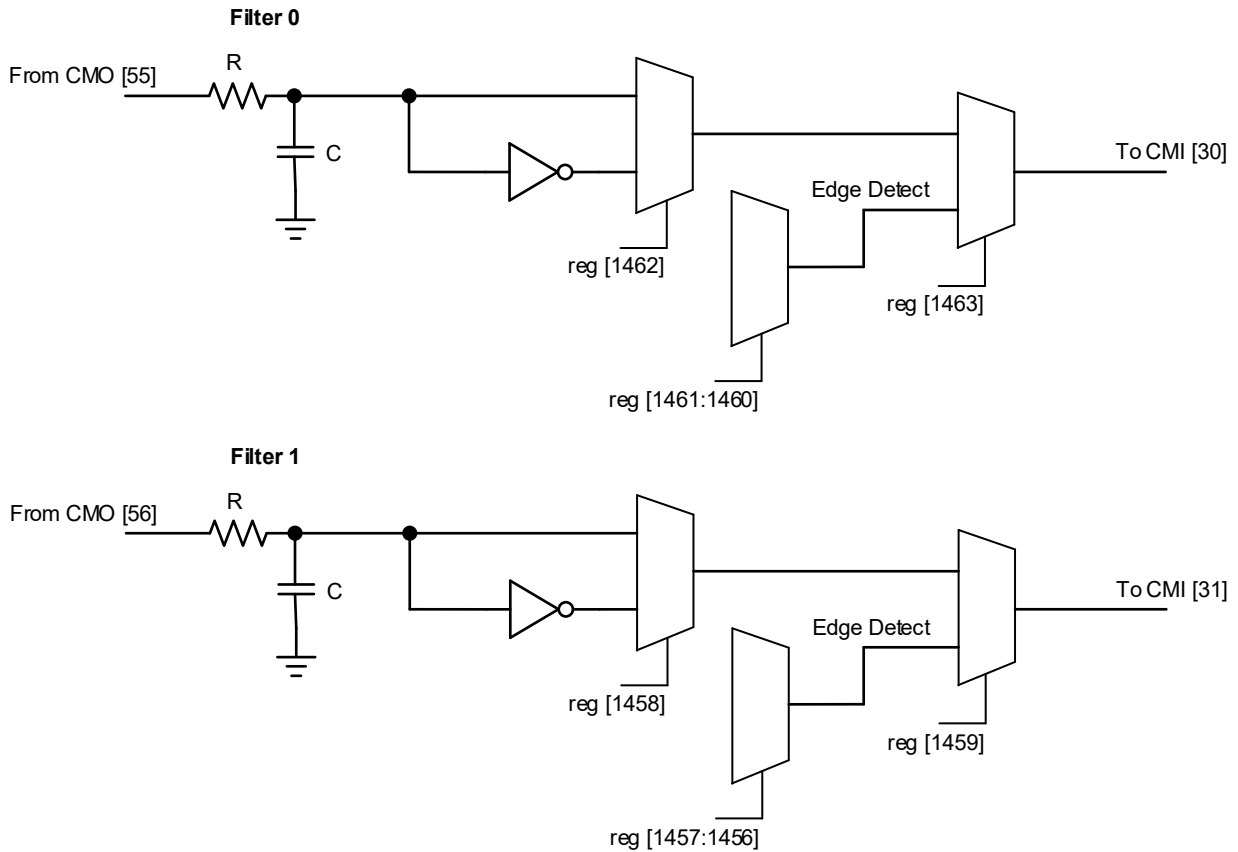

Figure 60. Deglitch Filter/Edge Detector

10. Voltage Reference

10.1 Voltage Reference Overview

The SLG46540 has a Voltage Reference (V_{REF}) Macrocell to provide references to the three analog comparators. This macrocell can supply a user selection of fixed voltage references, $/3$ and $/4$ reference off of the VDD power supply to the device, and externally supplied voltage references from Pins 5 and 10. See [Table 26](#) for the available selections for each analog comparator. Also, see [Figure 61](#), which shows the reference output structure.

Table 26. V_{REF} Selection Table

SEL[4:0]	ACMP0_ V_{REF}	ACMP1_ V_{REF}	ACMP2_ V_{REF}
11101	PIN 5: EXT_ V_{REF} /2	Reserved	Reserved
11100	Reserved	Reserved	Reserved
11011	PIN 5: EXT_ V_{REF}	Reserved	Reserved
11010	Reserved	Reserved	Reserved
11001	V_{DD} /4	V_{DD} /4	V_{DD} /4
11000	V_{DD} /3	V_{DD} /3	V_{DD} /3
10111	1.20	1.20	1.20
10110	1.15	1.15	1.15
10101	1.10	1.10	1.10
10100	1.05	1.05	1.05
10011	1.00	1.00	1.00
10010	0.95	0.95	0.95
10001	0.90	0.90	0.90
10000	0.85	0.85	0.85
01111	0.80	0.80	0.80
01110	0.75	0.75	0.75
01101	0.70	0.70	0.70
01100	0.65	0.65	0.65
01011	0.60	0.60	0.60
01010	0.55	0.55	0.55
01001	0.50	0.50	0.50
01000	0.45	0.45	0.45
00111	0.40	0.40	0.40
00110	0.35	0.35	0.35
00101	0.30	0.30	0.30
00100	0.25	0.25	0.25
00011	0.20	0.20	0.20
00010	0.15	0.15	0.15
00001	0.10	0.10	0.10

SEL[4:0]	ACMP0_VREF	ACMP1_VREF	ACMP2_VREF
00000	0.05	0.05	0.05

Table 27. Practical VREF Range of Voltage Reference Macrocell

V _{DD} Range	Practical V _{REF} Range	Note
2.0 V - 5.5 V	50 mV ~ 1.2 V	
1.7 V - 2.0 V	50 mV ~ 1.0 V	Do not operate above 1.0 V

10.2 VREF Block Diagram

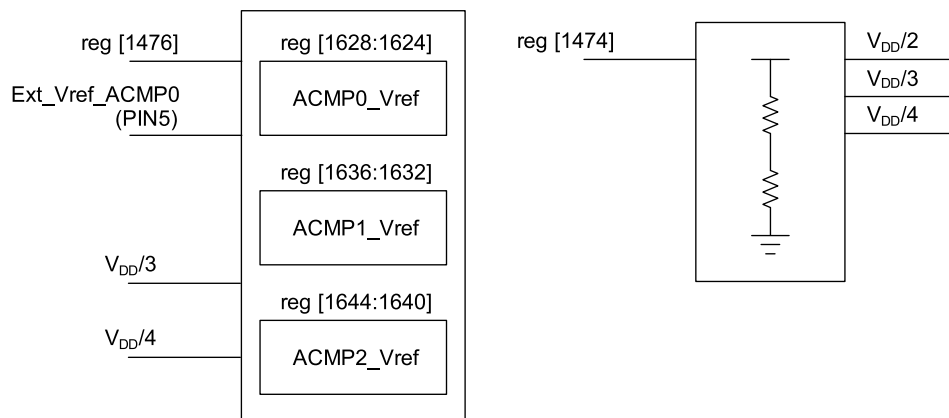

Figure 61. Voltage Reference Block Diagram

10.3 VREF Load Regulation

Note 1: VREF buffer performance is not guaranteed at V_{DD} < 2.7 V.

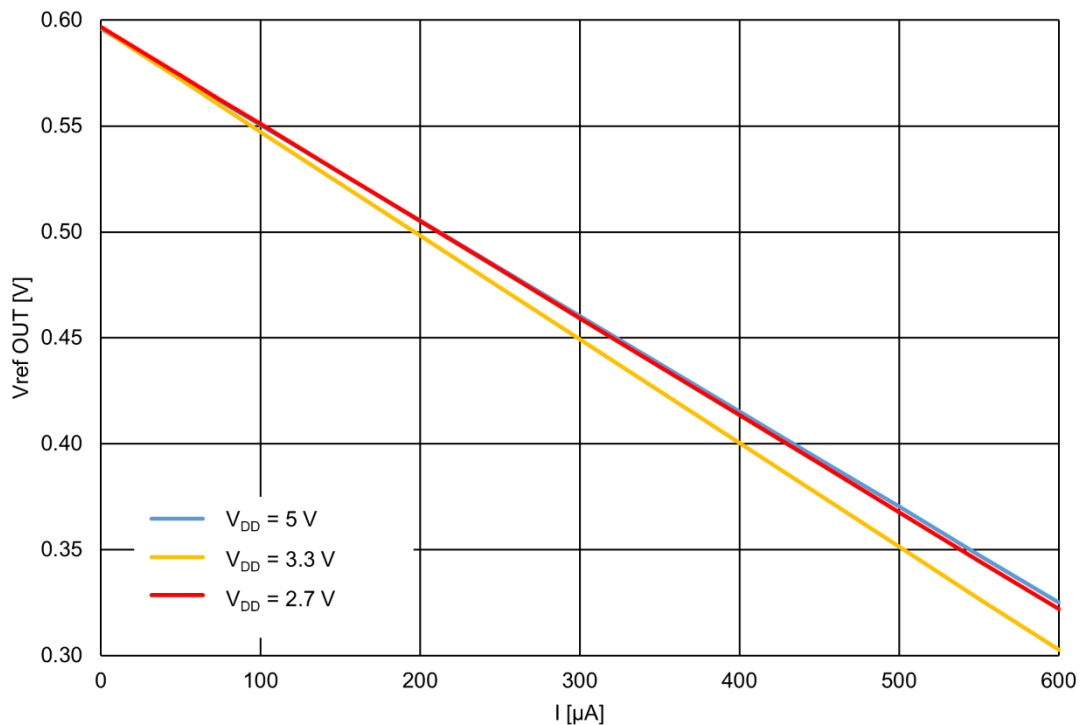

Figure 62. Typical Load Regulation, V_{REF} = 600 mV, T_A = -40 °C to +85 °C, Buffer – Enable

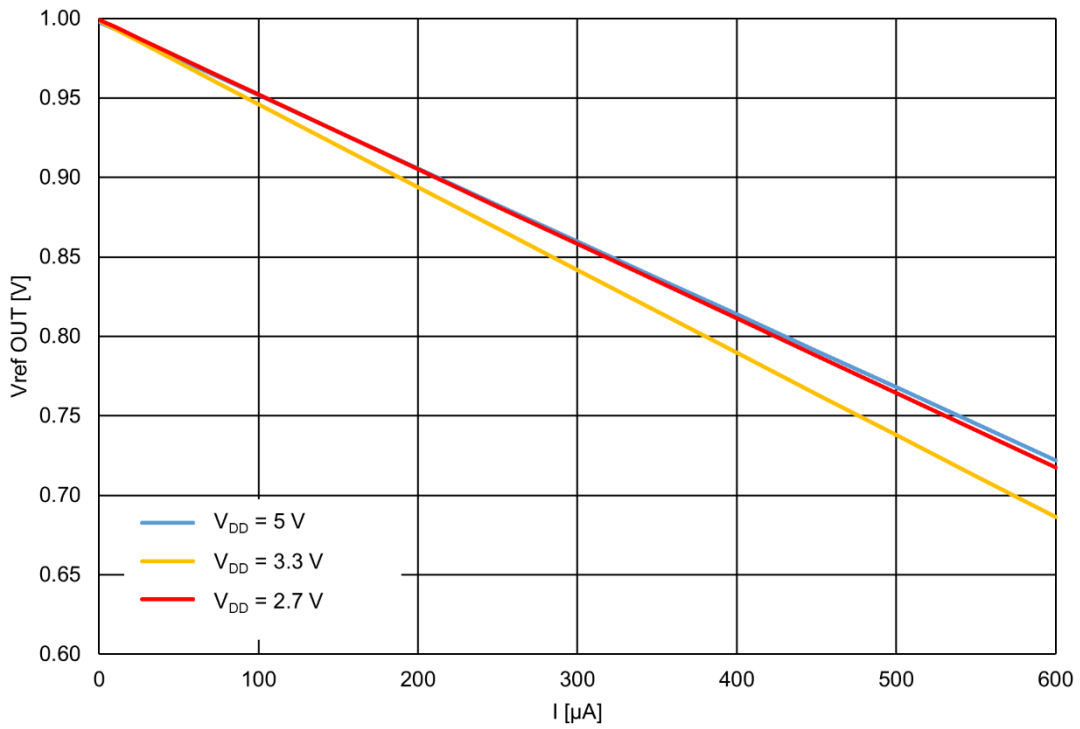

Figure 63. Typical Load Regulation, V_{REF} = 1000 mV, T_A = -40 °C to +85 °C, Buffer - Enable

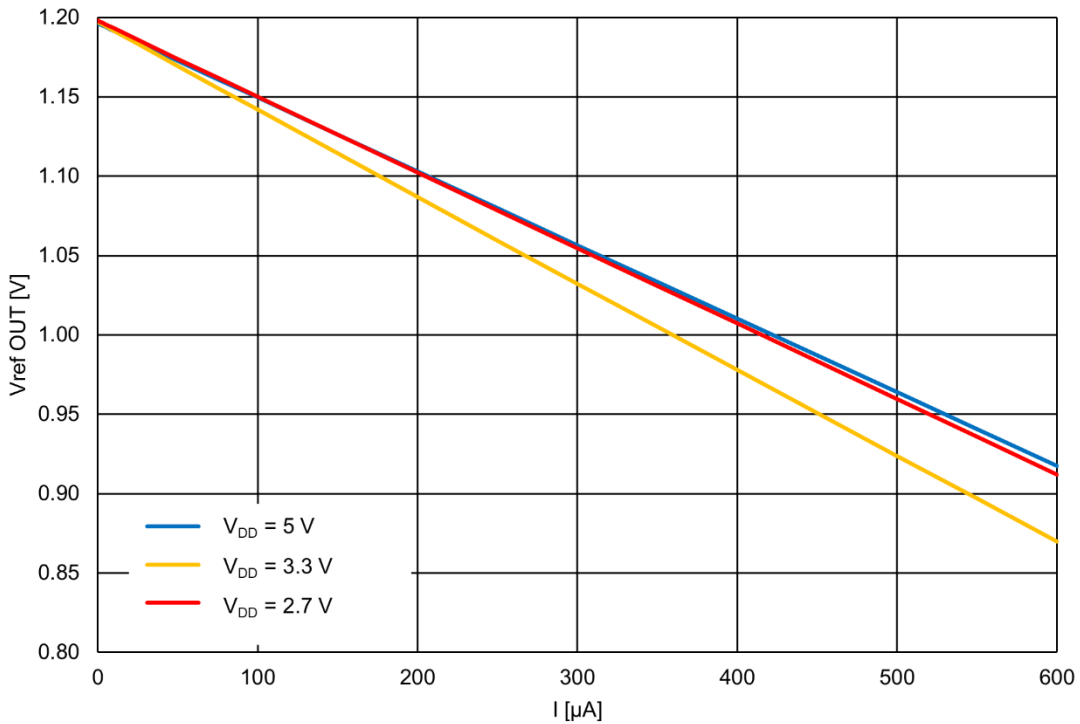

Figure 64. Typical Load Regulation, V_{REF} = 1200 mV, T_A = -40 °C to +85 °C, Buffer - Enable

11. Clocking

11.1 OSC General Description

The SLG46540 has two internal oscillators. Oscillator OSC0 that runs at 25 kHz / 2 MHz and Oscillator OSC1 that runs at 25 MHz. It is possible to use OSC0 and OSC1 simultaneously. The fundamental frequency can also come from clock input (Pin 14 for 25 kHz/2 MHz and Pin 13 for 25 MHz), see section [11.3 External Clocking](#).

11.2 25 kHz/2 MHz and 25 MHz Oscillators

There are two divider stages that allow the user flexibility for introducing clock signals on various Connection Matrix Input lines. The pre-divider allows the selection of /1, /2, /4, or /8 divide down frequency from the fundamental. The second stage divider (only for 25 kHz / 2 MHz Oscillator) has an input of frequency from the pre-divider, and outputs one of seven different frequencies on Connection Matrix Input lines [27] (OUT0) and [28] (OUT1). See [Figure 65](#) and [Figure 66](#) for details.

There are two modes of the POWER CONTROL pin, (register [1658] for 25 kHz/2 MHz OSC and register [1657] for 25 MHz OSC):

- **POWER-DOWN [0]**. If PWR CONTROL input of oscillator is LOW, the oscillator will be turned on. If PWR CONTROL input of oscillator is HIGH the oscillator will be turned off and OSC divider will reset.
- **FORCE ON [1]**. If PWR CONTROL input of oscillator is HIGH, the oscillator will be turned on. If PWR CONTROL input of oscillator is LOW the oscillator will be turned off.

The PWR CONTROL signal has the highest priority.

The SLG46540 has a 25 kHz/2 MHz OSC FAST START-UP function register [1338] (1 – on, 0 – off). It allows the OSC to run immediately after power-up this decreases the settling time. Note that when OSC FAST START-UP is on, the current consumption will rise.

The user can select two OSC POWER MODES (register [1343] for 25 kHz/2 MHz OSC and register [1341] for 25 MHz OSC):

- If **AUTO POWER-ON [0]** is selected, the OSC will run when any macrocell that uses OSC is powered on.
- If **FORCE POWER-ON [1]** is selected, the OSC will run when the SLG46540 is powered on.

OSC can be turned on by:

- Register control (force Power-On)
- Delay mode, when delay requires OSC
- CNT/FSM.

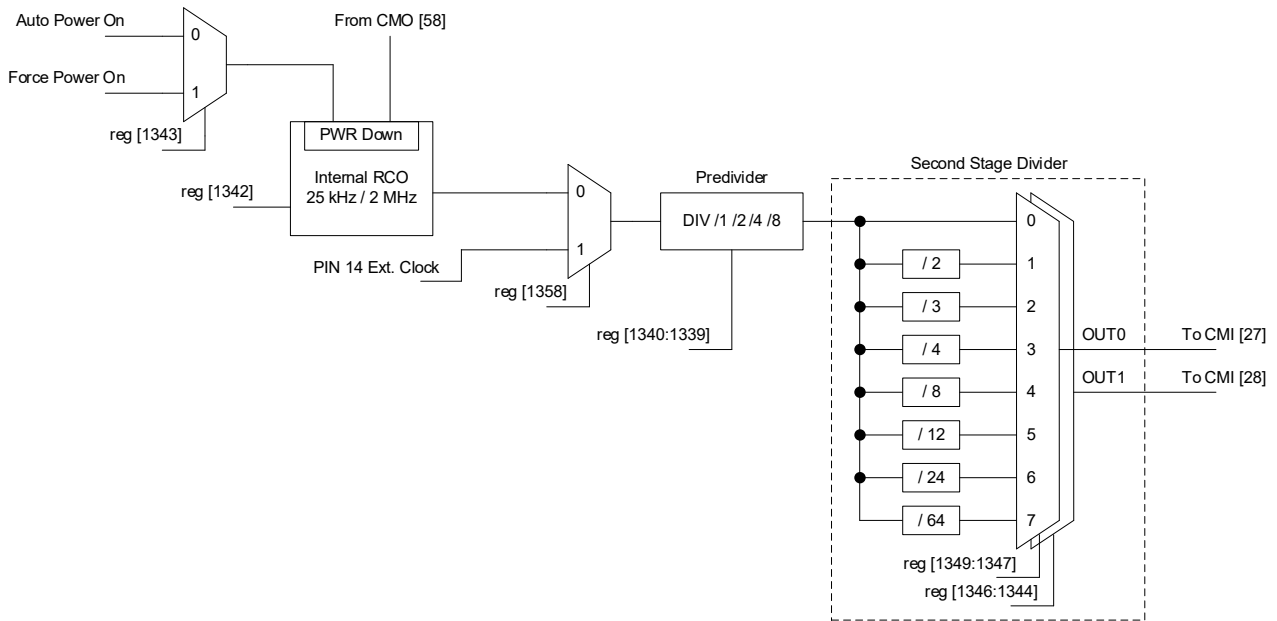

Figure 65. 25 kHz/2 MHz OSC0 Block Diagram

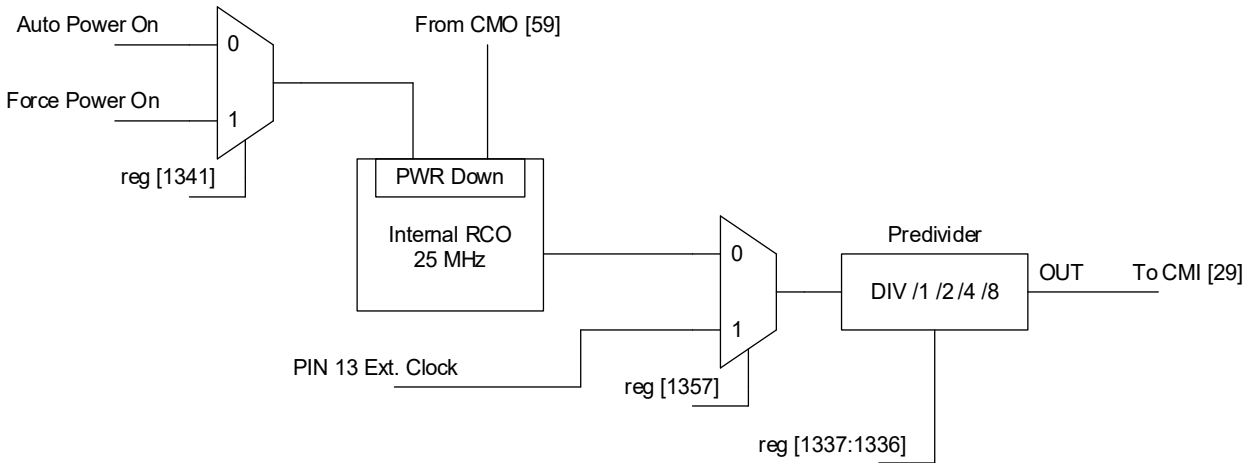

Figure 66. 25 MHz OSC1 Block Diagram

11.3 External Clocking

The SLG46540 supports several ways to use an external, higher accuracy clock as a reference source for internal operations.

11.3.1 Pin 14 Source for 25 kHz/2 MHz Clock

When register [1358] is set to 1, an external clocking signal on Pins 15 or 17 will be routed in place of the internal oscillator derived 25 kHz/2 MHz clock source. See [Figure 65](#).

The high and low limits for external frequency that can be selected are 0 MHz and 77 MHz.

11.3.2 Pin 13 Source for 25 MHz Clock

When register [1357] is set to 1, an external clocking signal on Pin 13 will be routed in place of the internal oscillator derived 25 MHz clock source. See [Figure 66](#). The high and low limits for external frequency that can be selected are 0 MHz and 84 MHz.

11.4 Oscillators Power-On Delay

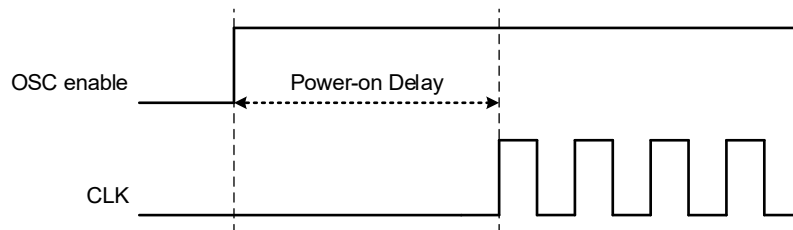

Figure 67. Oscillator Startup Diagram

Note 1: OSC power mode: “Auto Power-On”.

Note 2: “OSC enable” signal appears when any macrocell that uses OSC is powered on.

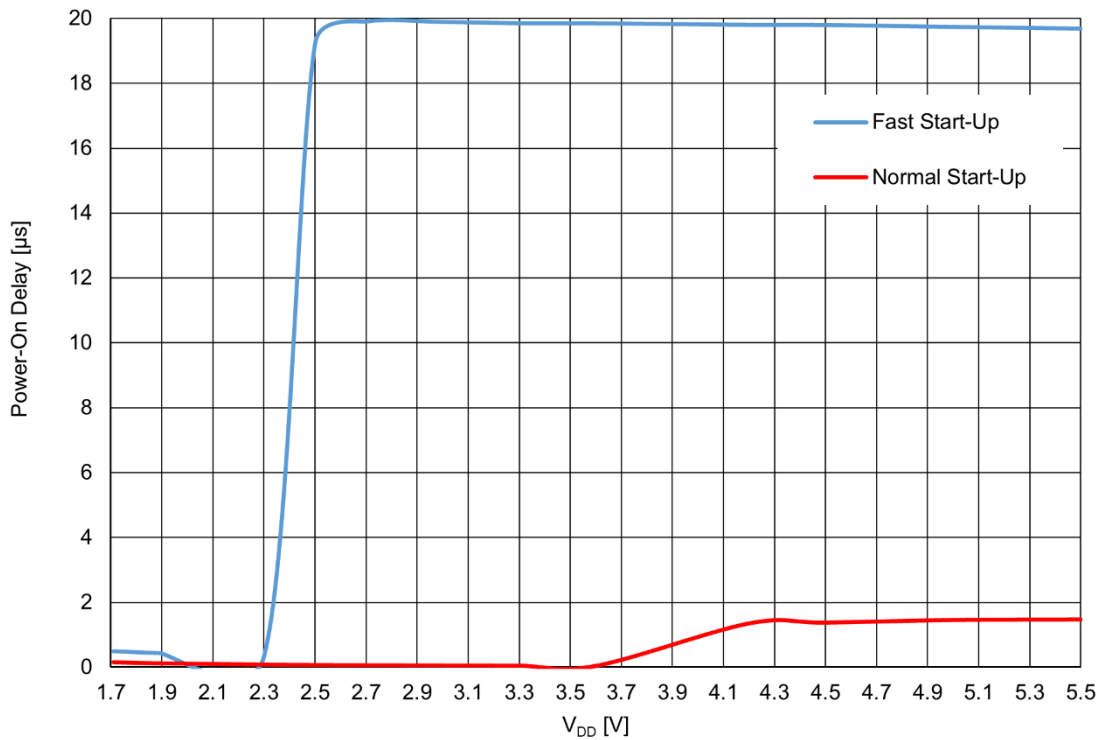

Figure 68. Oscillator Maximum Power-On Delay vs. V_{DD} at T_A = +25 °C, OSC0 = 25 kHz

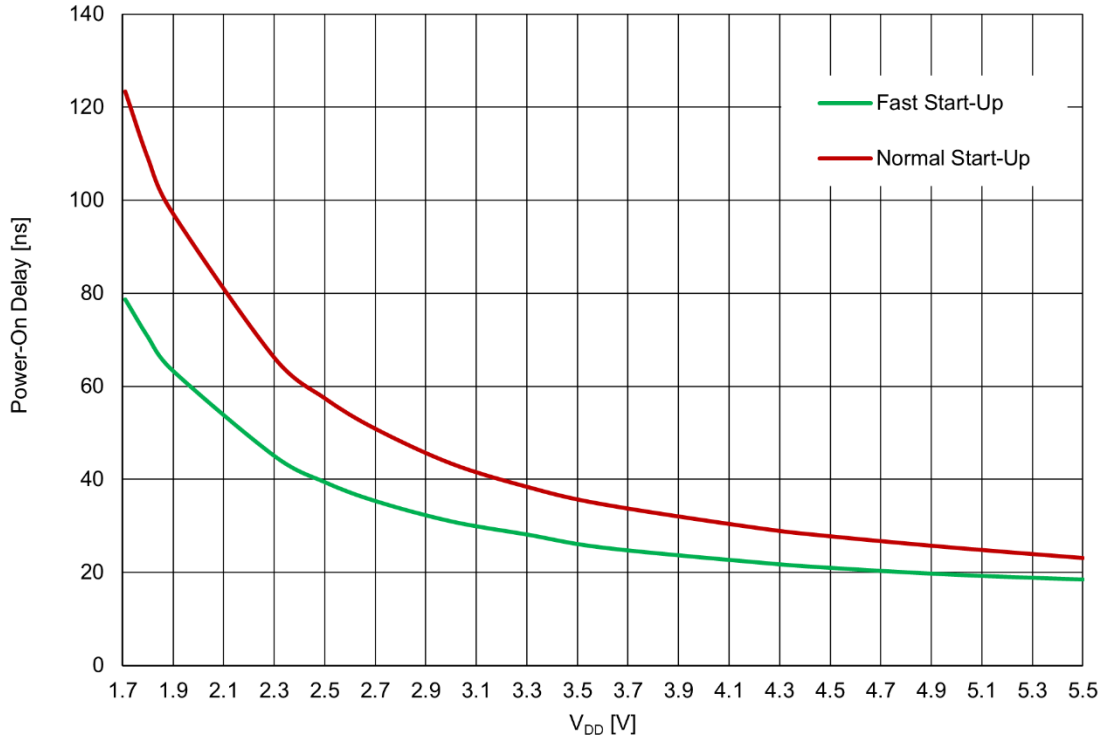

Figure 69. Oscillator Maximum Power-On Delay vs. V_{DD} at T_A = +25 °C, OSC0 = 2 MHz

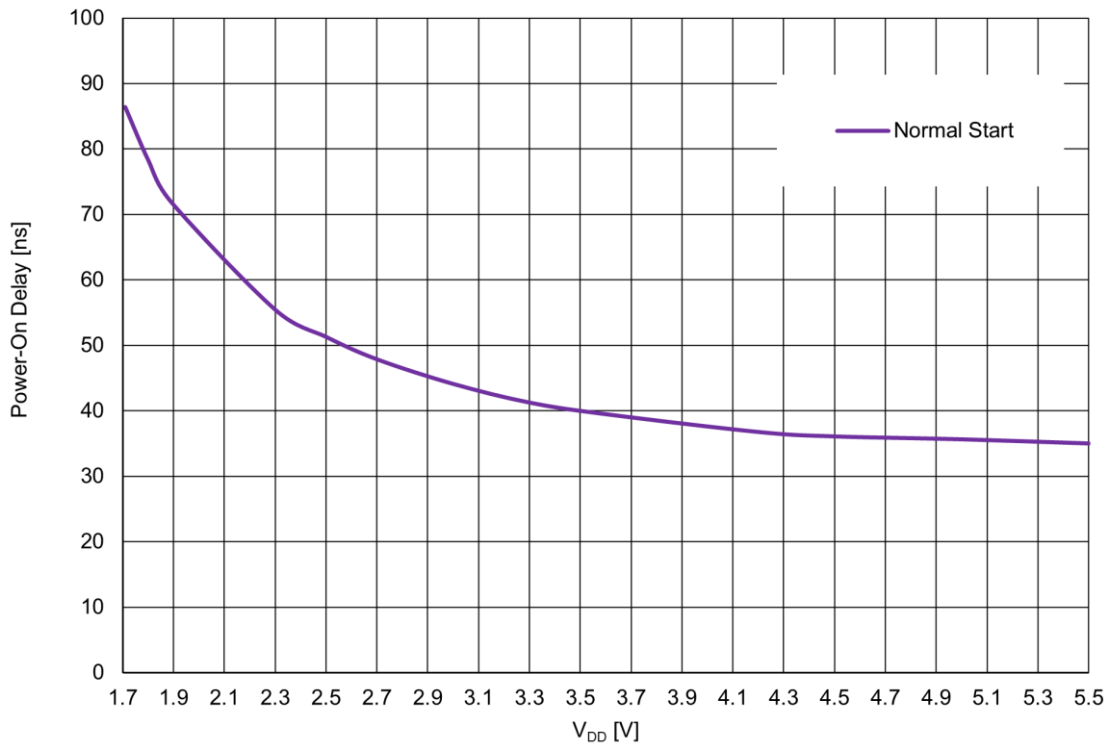

Figure 70. Oscillator Maximum Power-On Delay vs. V_{DD} at T_A = +25 °C, OSC1 = 25 MHz

11.5 Oscillators Accuracy

Note 1: OSC power setting: Force Power-On; Clock to matrix input - enable; Bandgap: turn on by register - enable.

Note 2: For more information see sections [3.4.8 25 kHz OSC0 Frequency Limits](#), [3.4.10 2 MHz OSC0 Frequency Limits](#), [3.4.12 25 MHz OSC1 Frequency Limits](#).

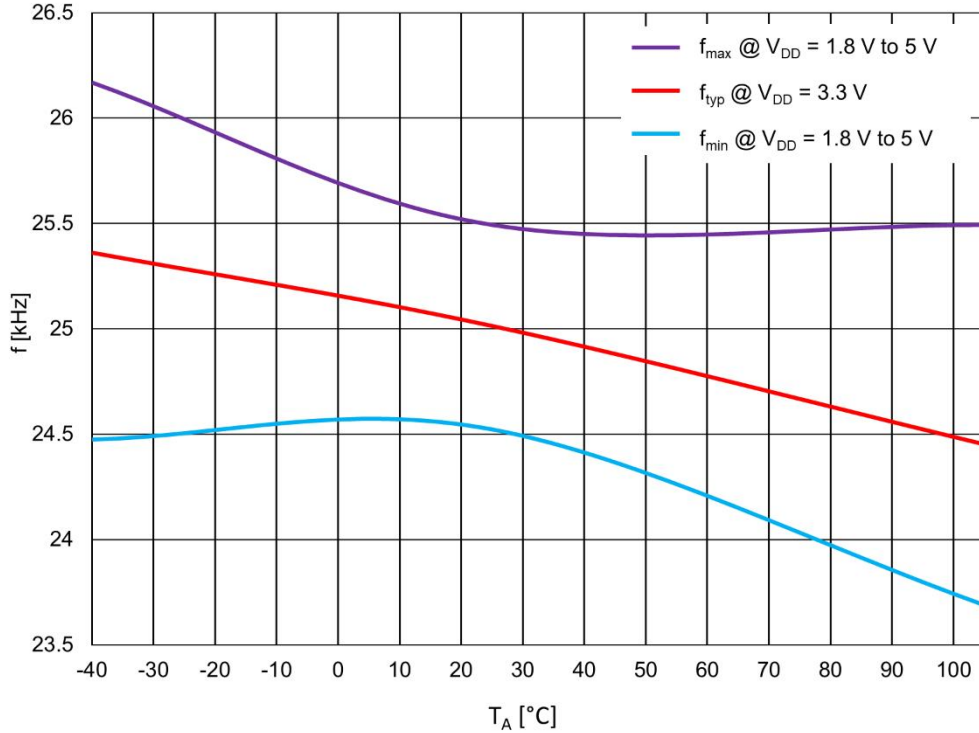

Figure 71. Oscillator Frequency vs. Ambient Temperature, OSC0 = 25 kHz

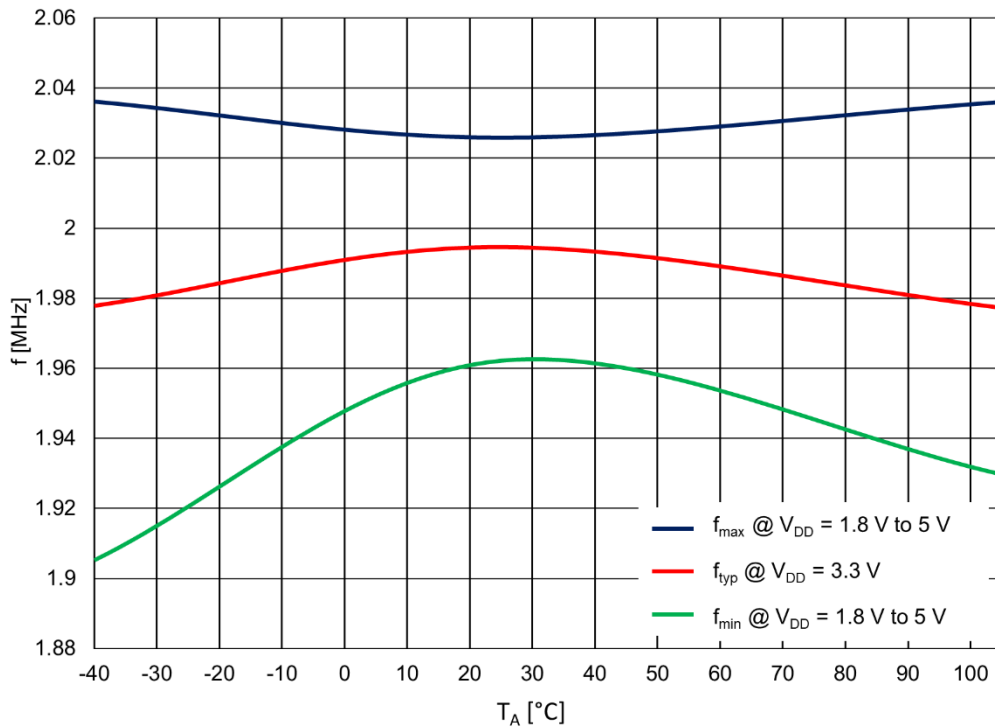

Figure 72. Oscillator Frequency vs. Ambient Temperature, OSC0 = 2 MHz

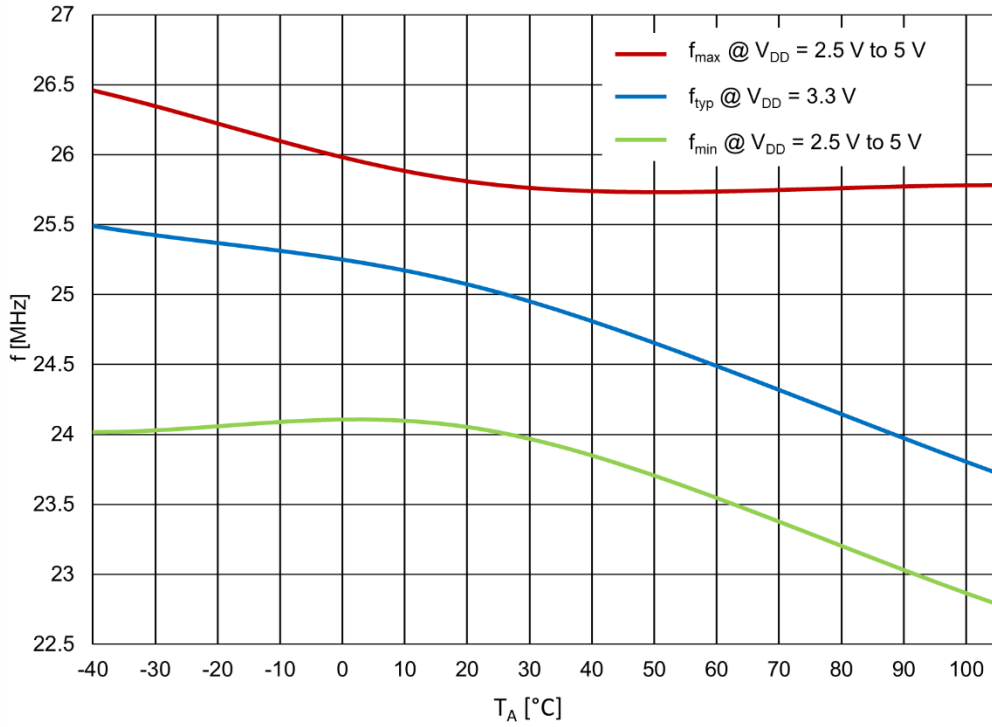

Figure 73. Oscillator Frequency vs. Ambient Temperature, OSC1 = 25 MHz

Note: 25 MHz OSC1 performance is not guaranteed at V_{DD} < 2.5 V.

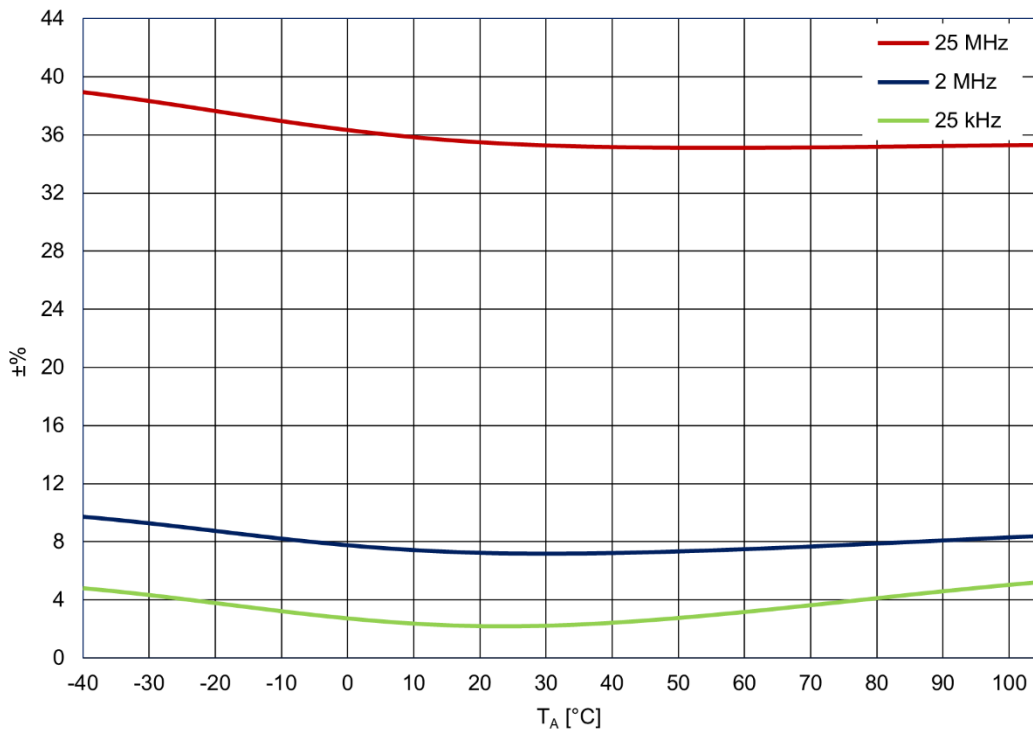

Figure 74. Oscillators Total Error vs. Ambient Temperature

11.6 Oscillators Settling Time

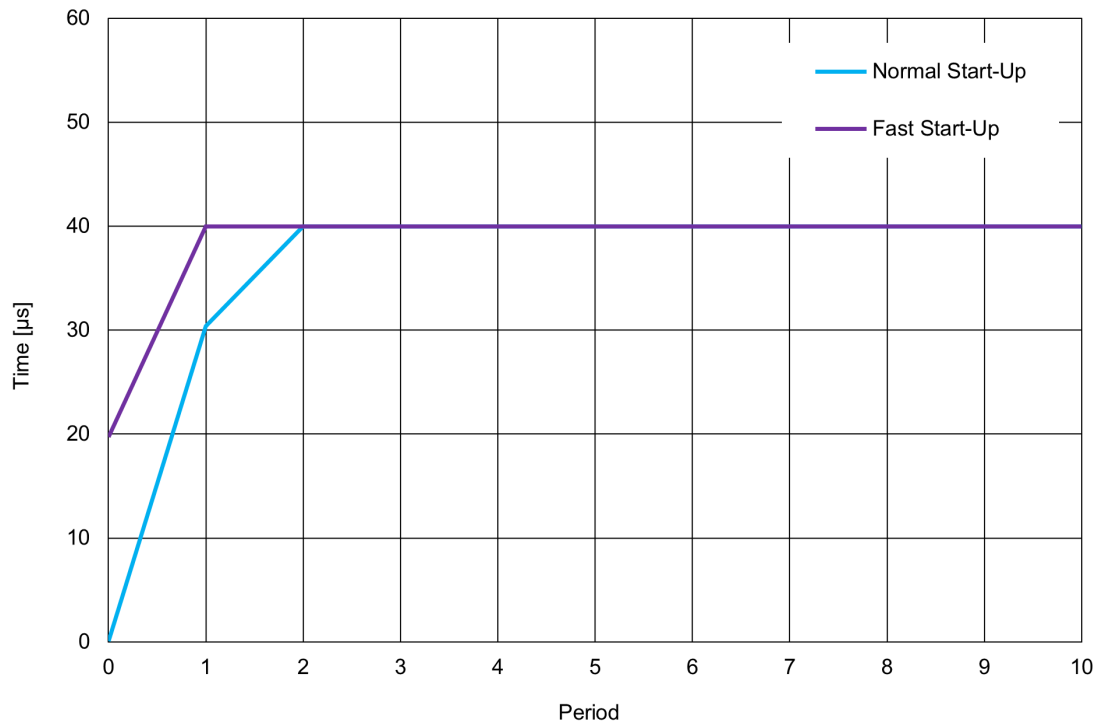

Figure 75. Oscillator0 Settling Time, $V_{DD} = 3.3\text{ V}$, $T_A = +25\text{ }^\circ\text{C}$, $OSC0 = 25\text{ kHz}$

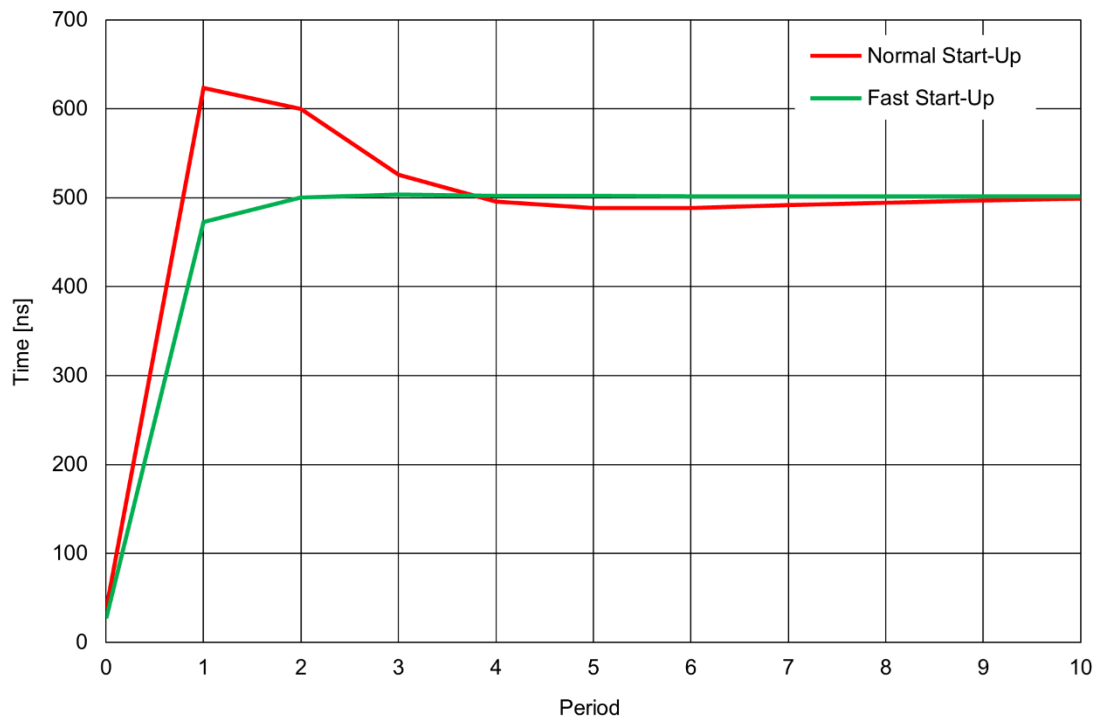

Figure 76. Oscillator0 Settling Time, $V_{DD} = 3.3\text{ V}$, $T_A = +25\text{ }^\circ\text{C}$, $OSC0 = 2\text{ MHz}$

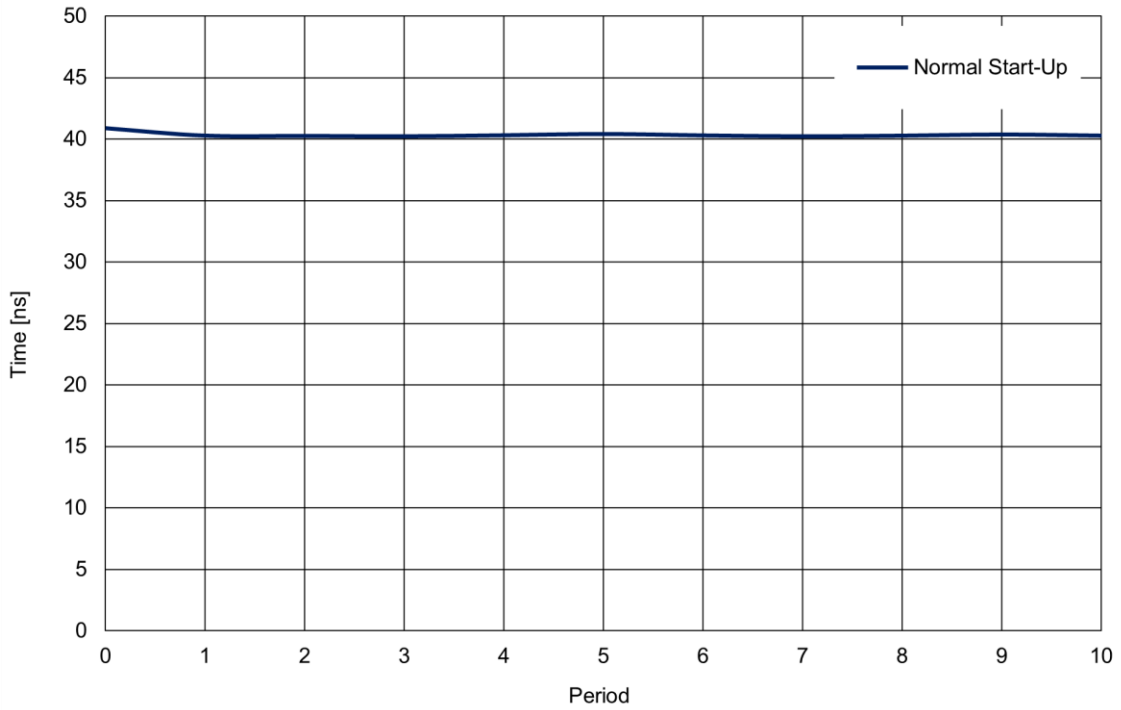

Figure 77. Oscillator0 Settling Time, $V_{DD} = 3.3\text{ V}$, $T_A = +25\text{ }^\circ\text{C}$, $OSC1 = 25\text{ MHz}$

11.7 Oscillators Current Consumption

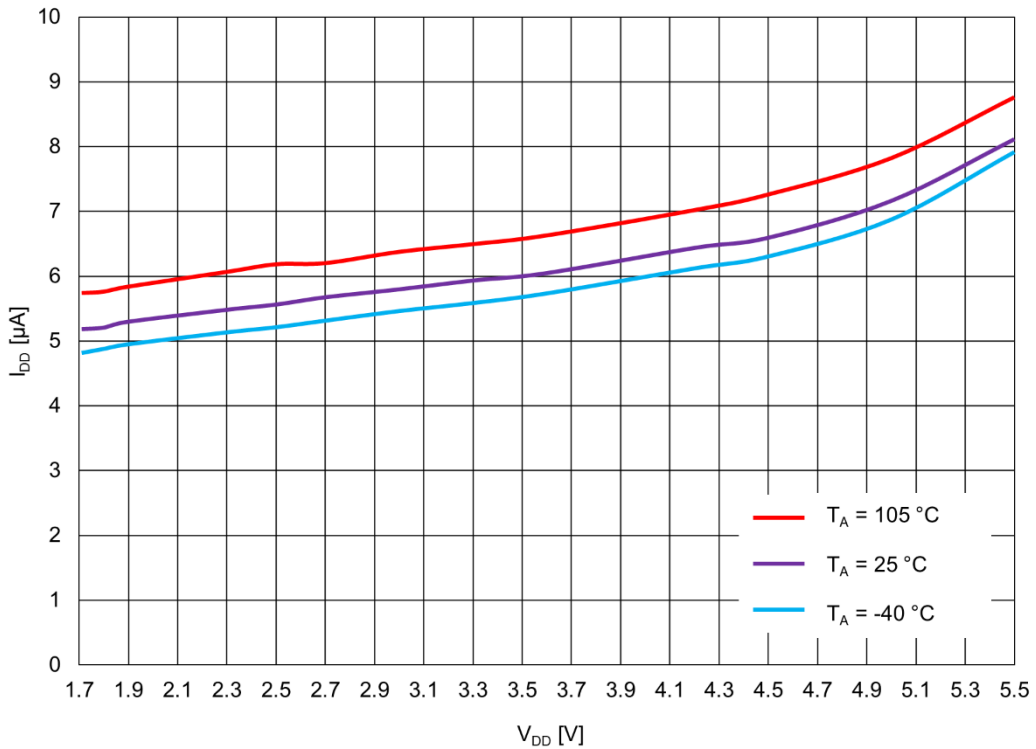

Figure 78. OSC0 (25 kHz) Current Consumption vs. V_{DD} , All Pre-Dividers

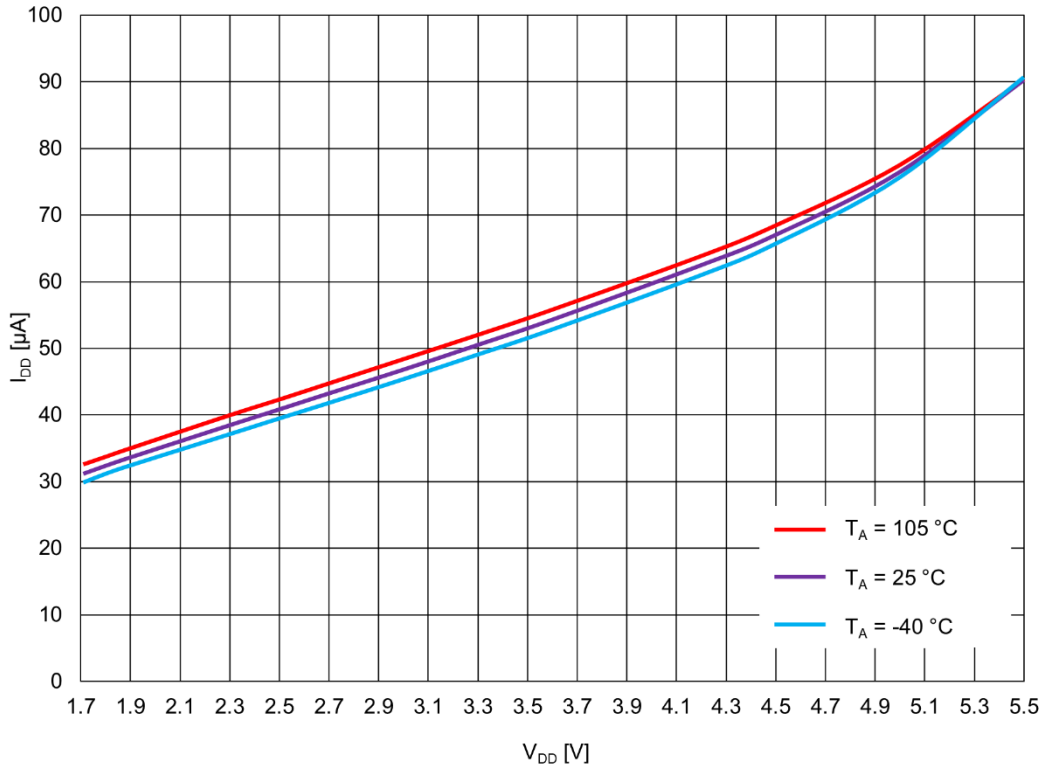

Figure 79. OSC0 (2 MHz) Current Consumption vs. V_{DD}, Pre-Divider = 1

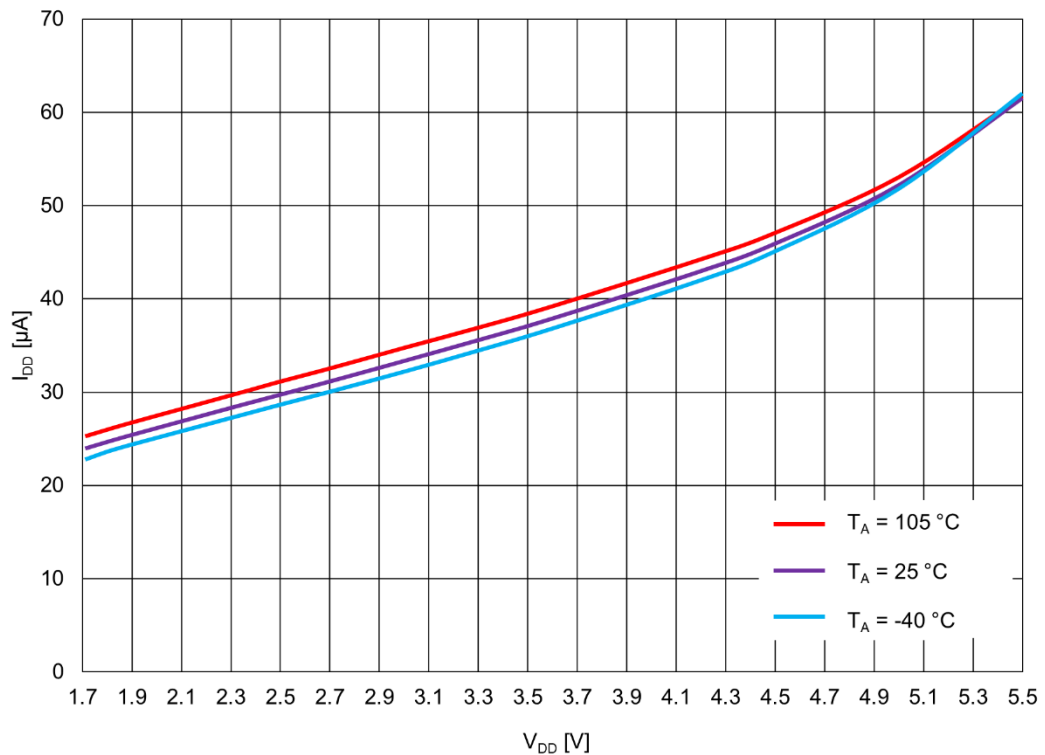

Figure 80. OSC0 (2 MHz) Current Consumption vs. V_{DD}, Pre-Divider = 2

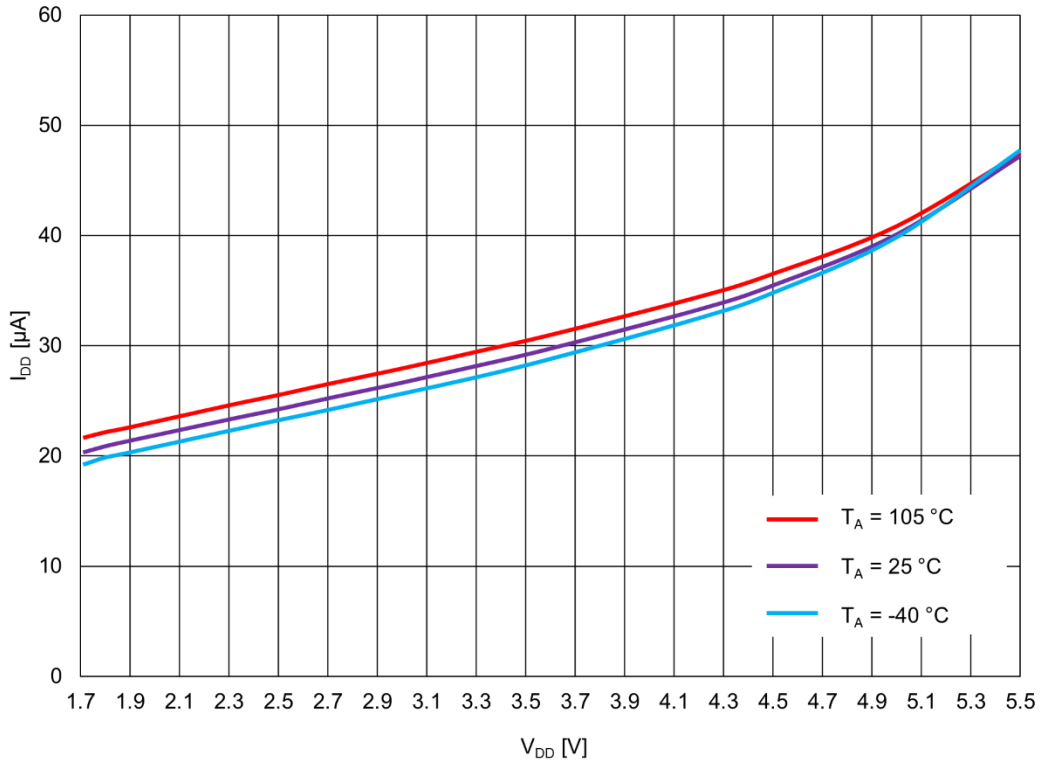

Figure 81. OSC0 (2 MHz) Current Consumption vs. V_{DD}, Pre-Divider = 4

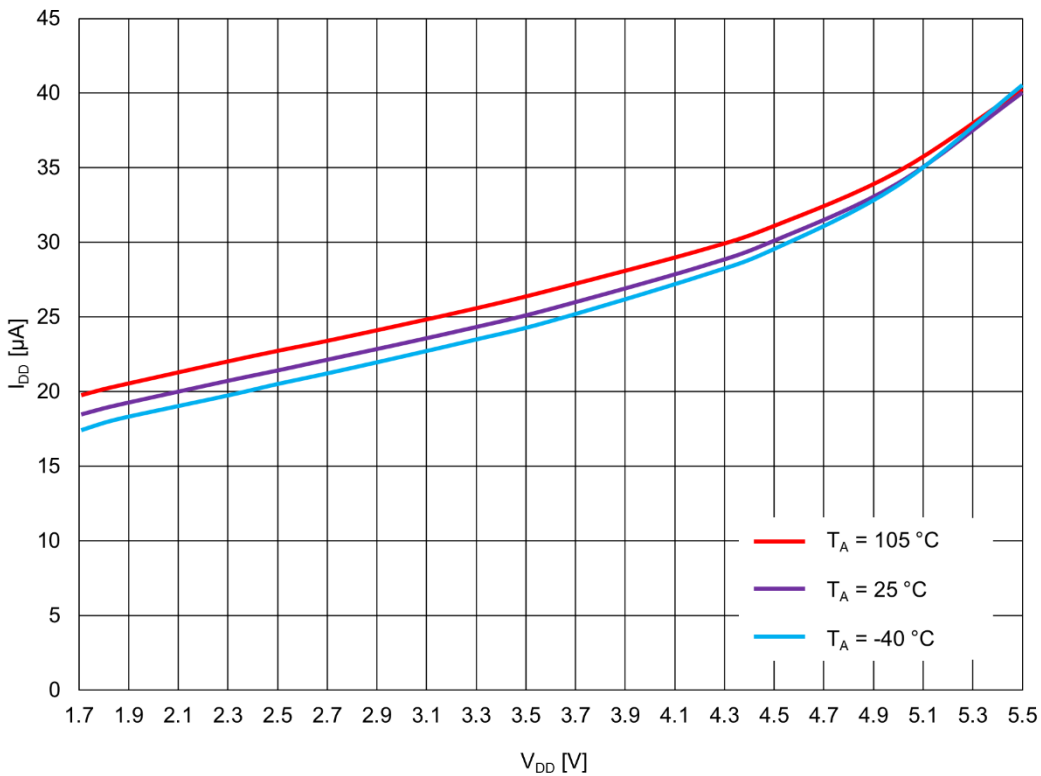

Figure 82. OSC0 (2 MHz) Current Consumption vs. V_{DD}, Pre-Divider = 8

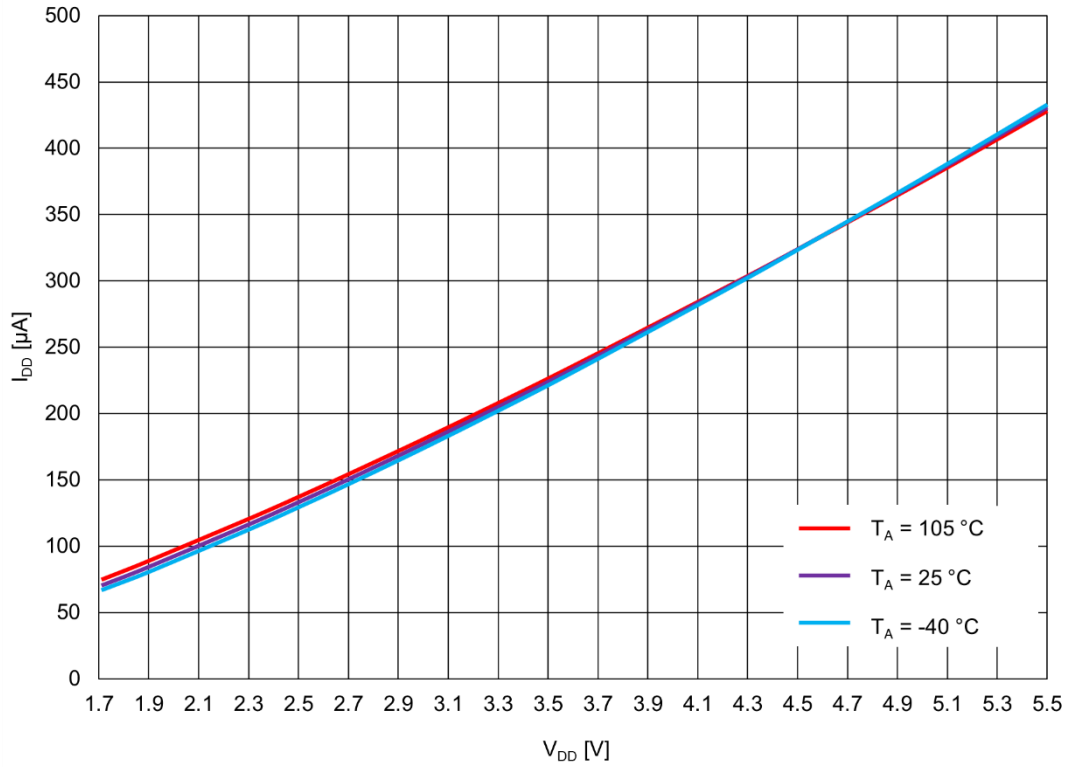

Figure 83. OSC1 (25 MHz) Current Consumption vs. V_{DD}, Pre-Divider = 1

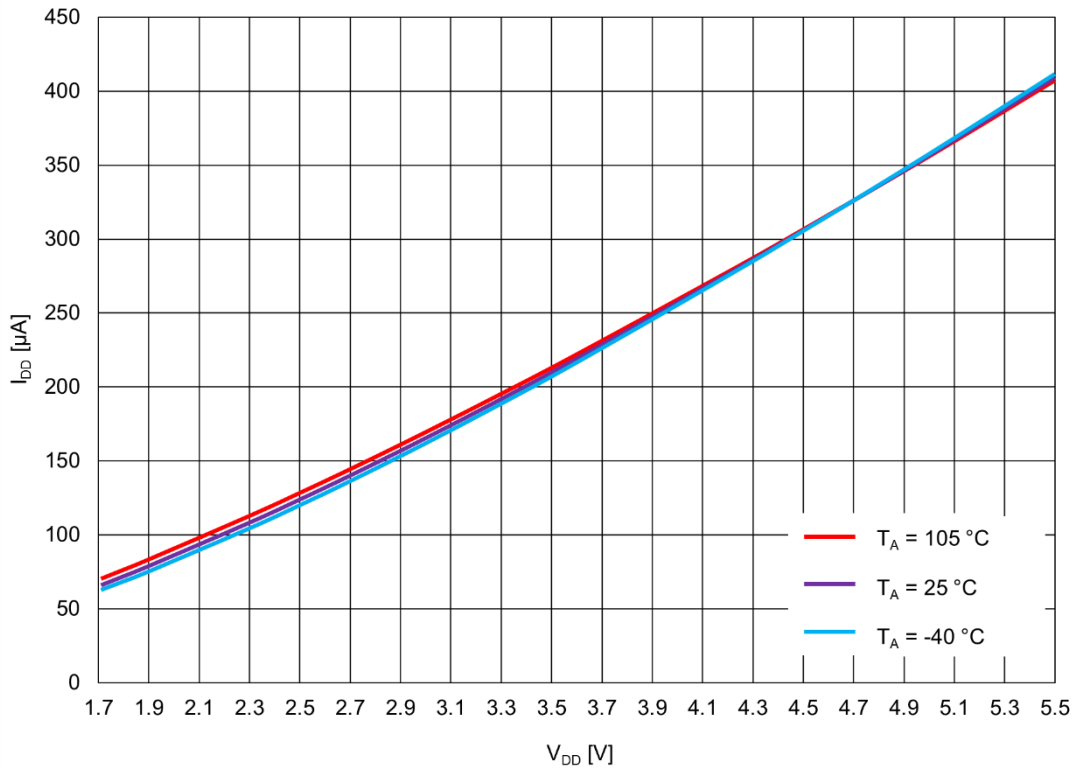

Figure 84. OSC1 (25 MHz) Current Consumption vs. V_{DD}, Pre-Divider = 2

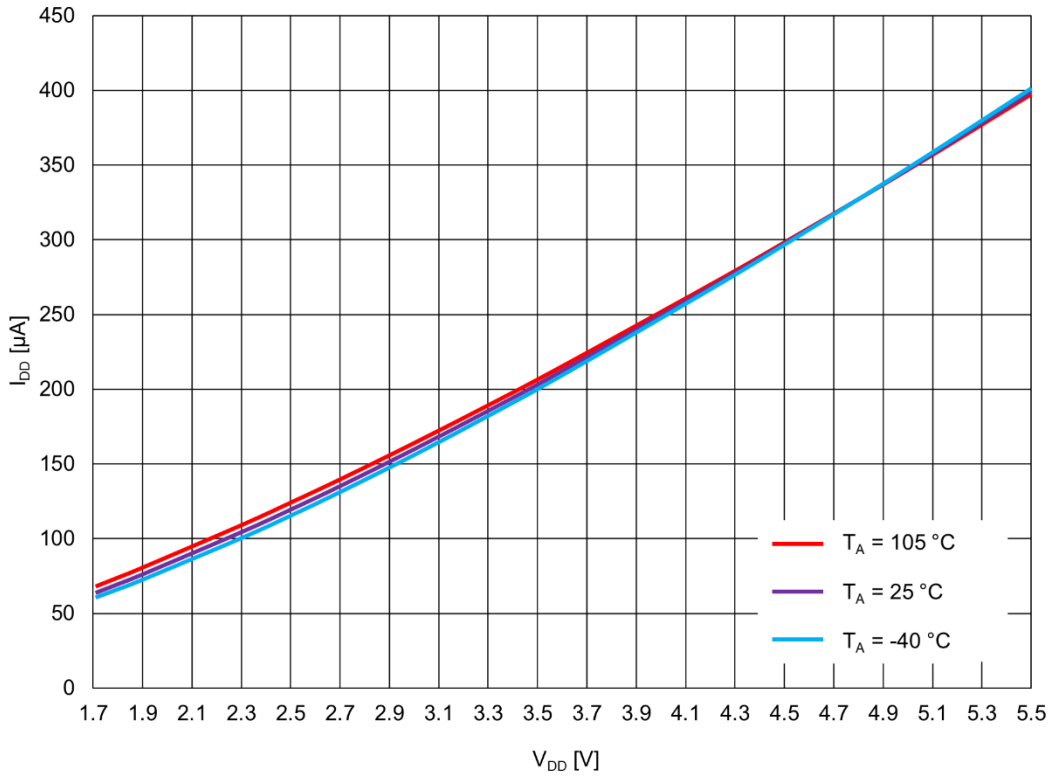

Figure 85. OSC1 (25 MHz) Current Consumption vs. V_{DD}, Pre-Divider = 4

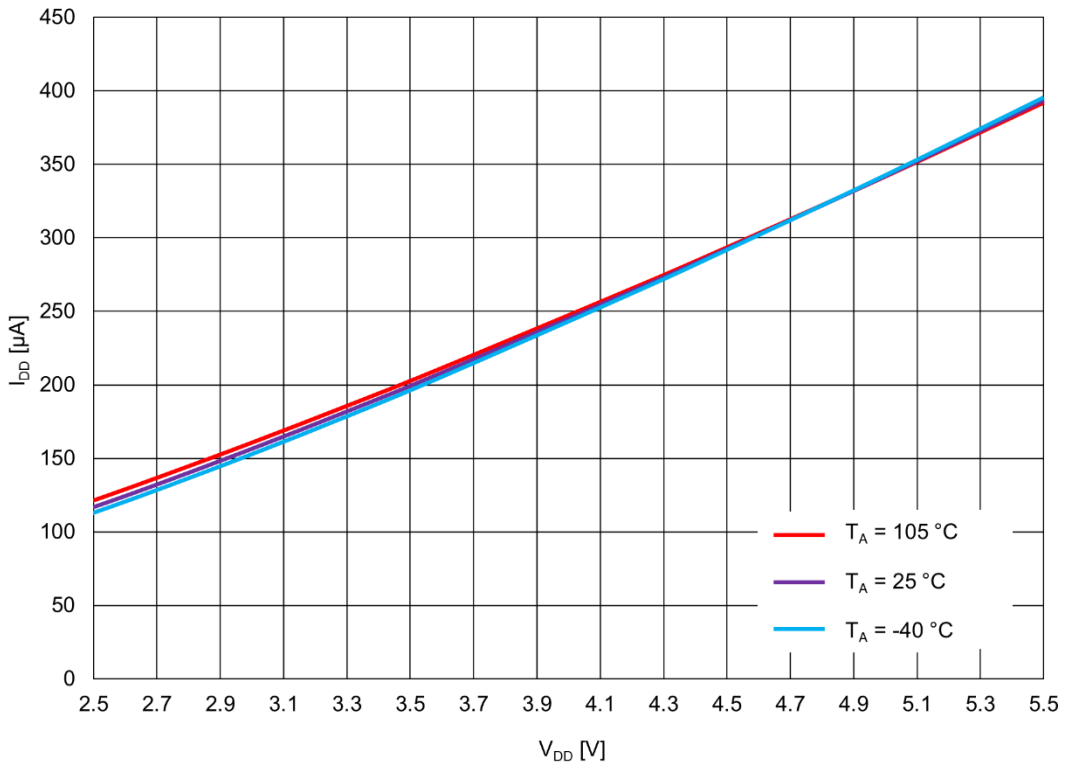

Figure 86. OSC1 (25 MHz) Current Consumption vs. V_{DD}, Pre-Divider = 8

12. Power-On Reset

The SLG46540 has a Power-On Reset (POR) macrocell to ensure correct device initialization and operation of all macrocells in the device. The purpose of the POR circuit is to have consistent behavior and predictable results when the V_{DD} power is first ramping to the device, and also while the V_{DD} is falling during power-down. To accomplish this goal, the POR drives a defined sequence of internal events that trigger changes to the states of different macrocells inside the device, and finally to the state of the IO pins.

12.1 General Operation

To start the POR sequence in the SLG46540, the voltage applied on the V_{DD} should be higher than the Power-On threshold ([Note 1](#)). The full operational V_{DD} range for the SLG46540 is 1.71 V to 5.5 V (1.8 V \pm 5 % to 5.0 V \pm 10 %). This means that the V_{DD} voltage must ramp up to the operational voltage value, but the POR sequence will start earlier, as soon as the V_{DD} voltage rises to the Power-On threshold. After the POR sequence has started, the SLG46540 will have a typical period of time to go through all the steps in the sequence (noted in the datasheet for that device), and will be ready and completely operational after the POR sequence is complete.

The SLG46540 is guaranteed to be powered down and nonoperational when the V_{DD} voltage (voltage on V_{DD}) is less than Power-Off Threshold ($POFF_{THR}$, see [3.4.1 Logic IO Specifications](#)), but not less than -0.6 V. Another essential condition for the chip to be powered down is that no voltage higher than the V_{DD} voltage is applied to any other Pin ([Note 2](#)). For example, if V_{DD} voltage is 0.3 V, applying a voltage higher than 0.3 V to any other Pin is incorrect, and can lead to incorrect or unexpected device behavior.

Note 1: The Power-On threshold is defined in Electrical Characteristics table.

Note 2: There is a 0.6 V margin due to forward drop voltage of the ESD protection diodes.

To power down the chip the V_{DD} voltage should be lower than the operational and to guarantee that chip is powered down it should be less than Power-Off Threshold.

All Pins are in high impedance state when the chip is powered down and while the POR sequence is taking place. The last step in the POR sequence releases the IO structures from the high impedance state, at which time the device is operational. The pin configuration at this point in time is defined by the design programmed into the chip. Also, as it was mentioned before the voltage on Pins can't be higher than the V_{DD} , this rule also applies to the case when the chip is powered on.

12.2 POR Sequence

The POR system generates a sequence of signals that enable certain macrocells. The sequence is shown in Figure 87.

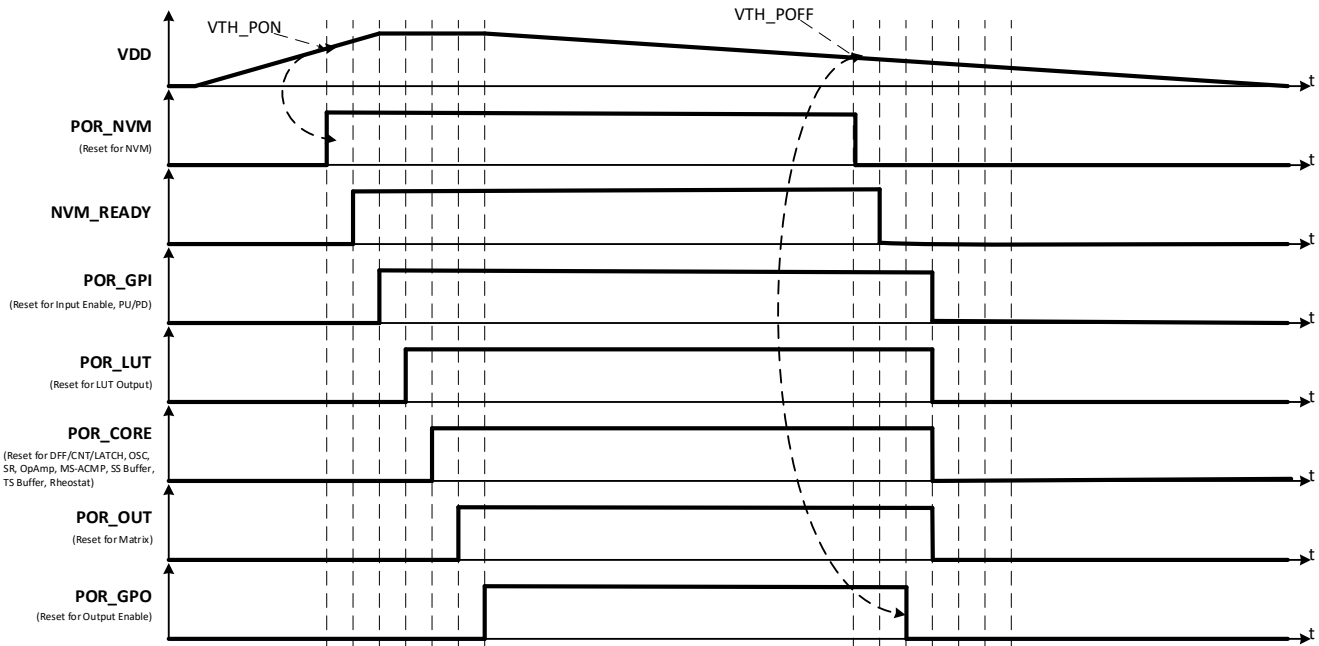

Figure 87. POR Sequence

As can be seen from Figure 87 after the V_{DD} has start ramping up and crosses the Power-On threshold, first, the on-chip NVM memory is reset. Next, the chip reads the data from NVM, and transfers this information to SRAM registers that serve to configure each macrocell, and the Connection Matrix which routes signals between macrocells. The third stage causes the reset of the input pins, and then to enable them. After that, the LUTs are reset and become active. After LUTs, the Delay cells, OSC, DFFs, LATCHES, and Pipe Delay are initialized. Only after all macrocells are initialized internal POR signal (POR macrocell output) goes from LOW to HIGH. The last portion of the device to be initialized are the output Pins, which transition from high impedance to active at this point.

The typical time that takes to complete the POR sequence varies by device type in the GreenPAK family. It also depends on many environmental factors, such as: slew rate, V_{DD} , temperature, and even will vary from chip to chip (process influence).

12.3 Macrocells Output States During POR Sequence

To have a full picture of SLG46540 operation during powering and POR sequence, review the overview the macrocell output states during the POR sequence (Figure 88 describes the output signals states).

First, before the NVM has been reset, all macrocells have their output set to logic LOW (except the output Pins which are in high impedance state). Before the NVM is ready, all macrocell outputs are unpredictable (except the output Pins). On the next step, some of the macrocells start initialization: input pins output state becomes LOW; LUTs also output LOW. Only P DLY macrocell configured as edge detector becomes active at this time. After that input Pins are enabled. Next, only LUTs are configured. Next, all other macrocells are initialized. After macrocells are initialized, internal POR matrix signal switches from LOW to HIGH. The last are output Pins that become active and determined by the input signals.

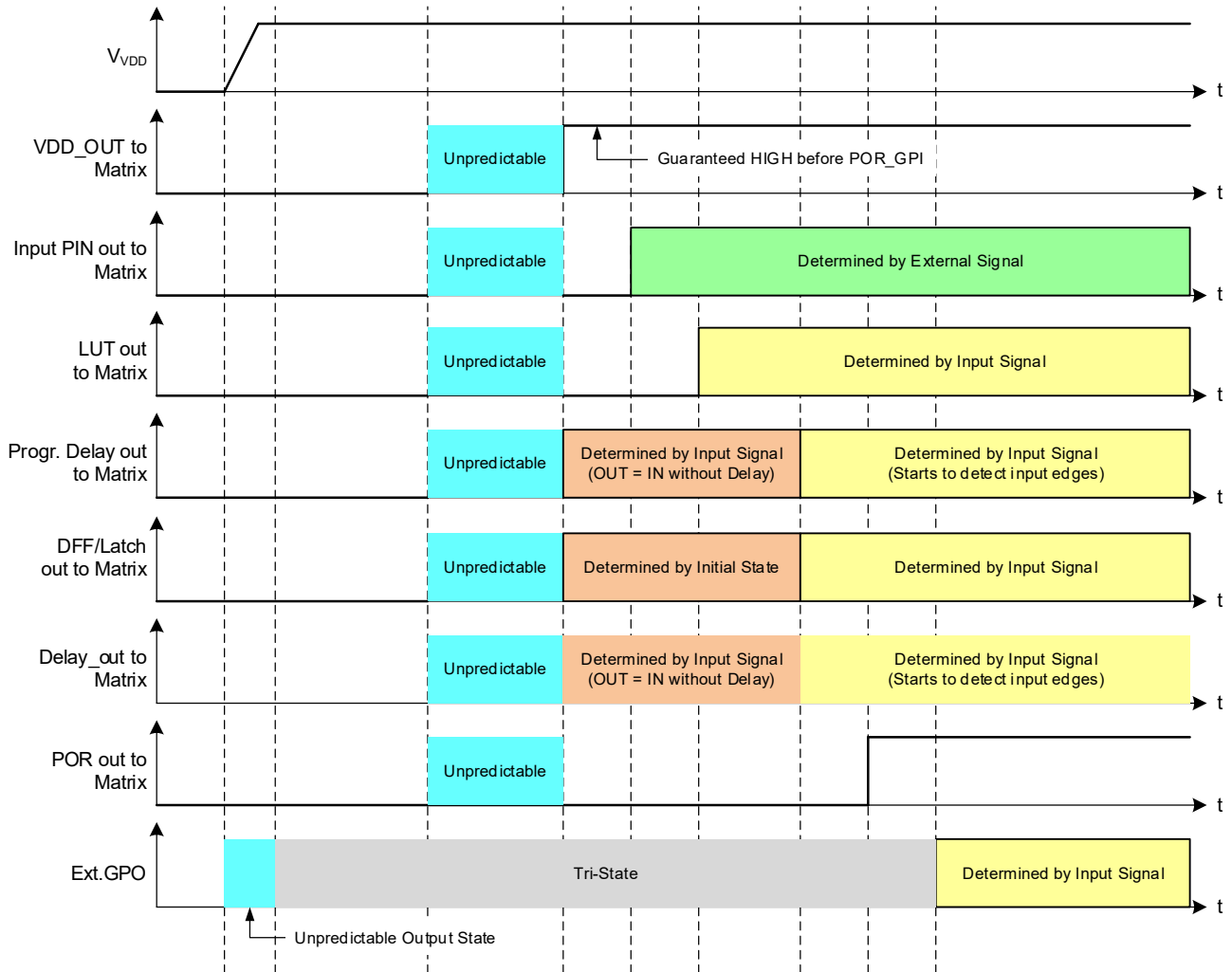

Figure 88. Internal Macrocell States during POR Sequence

12.3.1 Initialization

All internal macrocells by default have initial LOW level. Starting from indicated power-up time of 1.15 V to 1.6 V, macrocells in GPAK are powered on while forced to the reset state. All outputs are in Hi-Z and chip starts loading data from NVM. Then the reset signal is released for internal macrocells and they start to initialize according to the following sequence:

1. I²C.
2. Input Pins, ACMP, Pull-up/down.
3. LUTs.
4. DFFs, Delays/Counters, Pipe Delay.
5. POR output to matrix.
6. Output Pin corresponds to the internal logic.

The POR signal going high indicates the mentioned power-up sequence is complete.

Note: The maximum voltage applied to any Pin should not be higher than the V_{DD} level. There are ESD Diodes between Pin → V_{DD} and Pin → GND on each Pin. So, if the input signal applied to PIN is higher than V_{DD}, then current will sink through the diode to V_{DD}. Exceeding V_{DD} results in leakage current on the input PIN, and V_{DD} will be pulled up, following the voltage on the input Pin. There is no effect from input pin when input voltage is applied at the same time as V_{DD}.

12.3.2 Power-Down

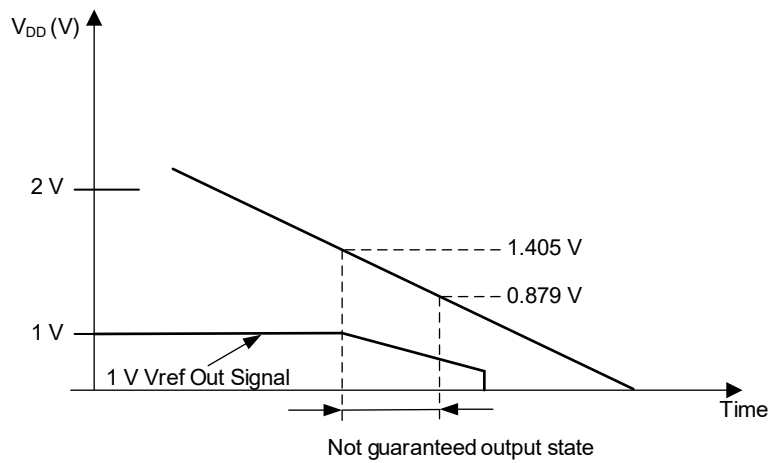

Figure 89. Power-Down

During power-down, macrocells in SLG46540 are powered off after V_{DD} falling down below Power-Off Threshold. Please note that during a slow ramp down, outputs can possibly switch state during this time.

13. I²C Serial Communications Macrocell

13.1 I²C Serial Communications Macrocell Overview

In the standard use case for the GreenPAK devices, the configuration choices made by the user are stored as bit settings in the Non-Volatile Memory (NVM), and this information is transferred at startup time to volatile RAM registers that enable the configuration of the macrocells. Other RAM registers in the device are responsible for setting the connections in the Connection Matrix to route signals in the manner most appropriate for the user's application.

The I²C Serial Communications Macrocell in this device allows an I²C bus Controller to read and write this information via a serial channel directly to the RAM registers, allowing the remote re-configuration of macrocells, and remote changes to signal chains within the device.

An I²C bus Controller is also able read and write other register bits that are not associated with NVM memory. As an example, the input lines to the Connection Matrix can be read as digital register bits. These are the signal outputs of each of the macrocells in the device, giving an I²C bus Controller the capability to remotely read the current value of any macrocell.

The user has the flexibility to control read access and write access via registers bits register [1832], register [1870], and register [1871]. See section [13.6 I²C Serial Command Register Protection](#) for more details on I²C read/write memory protection.

Note: GreenPAK I²C is fully compatible with standard I²C protocol.

13.2 I²C Serial Communications Device Addressing

Each command to the I²C Serial Communications macrocell begins with a valid START condition, defined as a HIGH to LOW transition (falling edge) on the SDA line while the SCL line is held HIGH. After a valid START condition, the Controller can send data to a Target such as the SLG46540. The first byte transmitted consists of a 7-bit Target Address and one bit for read/write. The address can be set by the user in reg [1734:1728]. This gives the user flexibility on the chip level addressing of this device and other devices on the same I²C bus. The last bit in the first byte transmitted is the R/W bit, which selects whether a read command or write command is requested, with a "1" selecting for a Read command, and a "0" selecting for a Write command. This first byte will be followed by an Acknowledge bit (ACK), which is sent by this device to the Controller to indicate successful communication.

In the I²C-bus specification and user manual, there are two groups of eight addresses (0000 xxx and 1111 xxx) that are reserved for the special functions, such as a system General Call address. If the user of this device chooses to set the first four bits of a device address to either "1111" or "0000" in a system with one or more additional Targets, please consult the I²C-bus specification and user manual to understand the addressing and implementation of these special functions, to ensure reliable operation.

In the read and write command address structure, there are a total of 8 bits of addressing, each pointing to a unique byte of information, resulting in a total address space of 2K bytes. Of this 2K byte address space, the valid addresses accessible to the I²C Macrocell on the SLG46540 are in the range from 0 (0x00) to 255 (0xFF).

With the exception of the Current Address Read command, all commands will begin with the Target Address and R/W bit followed by a second byte, the Word Address. [Figure 90](#) shows this basic command structure.

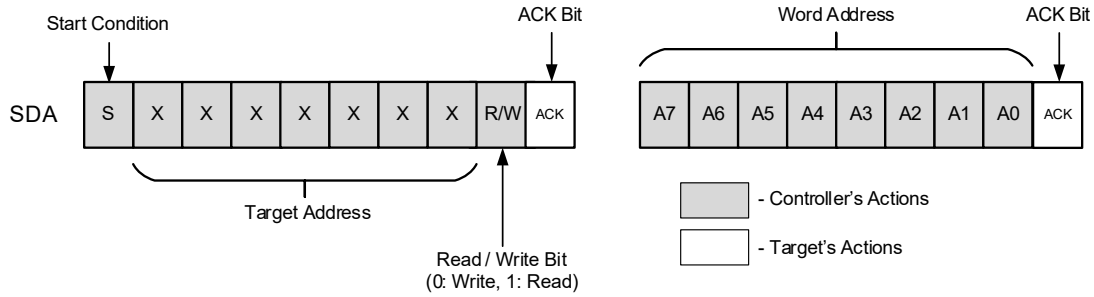

Figure 90. Basic Command Structure

13.3 I²C Serial General Timing

General timing characteristics for the I²C Serial Communications macrocell are shown in Figure 91. Timing specifications can be found in section 3.4.2 I²C Pins Electrical Specifications.

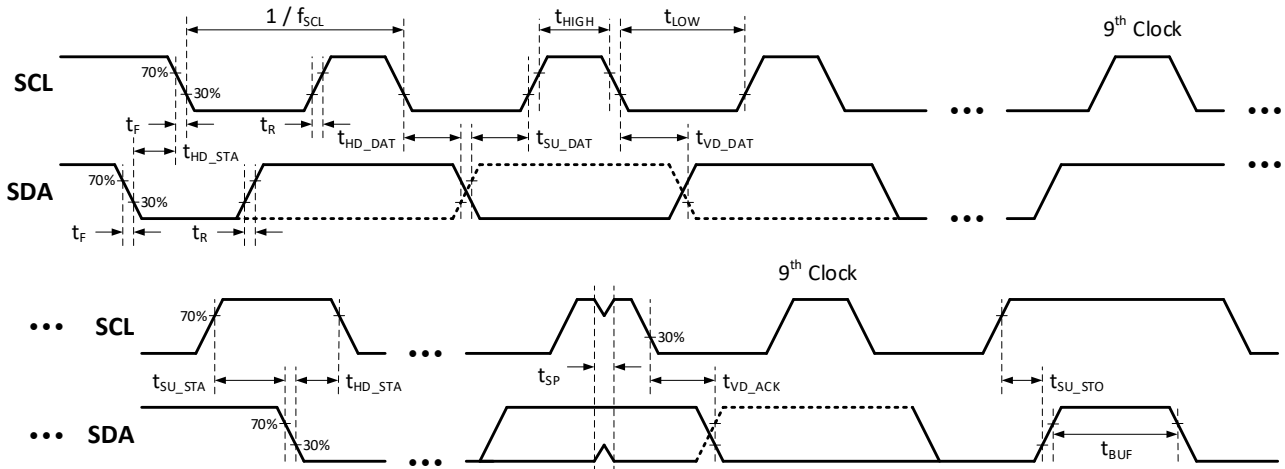

Figure 91. I²C General Timing Characteristics

13.4 I²C IO Expander Output Timing

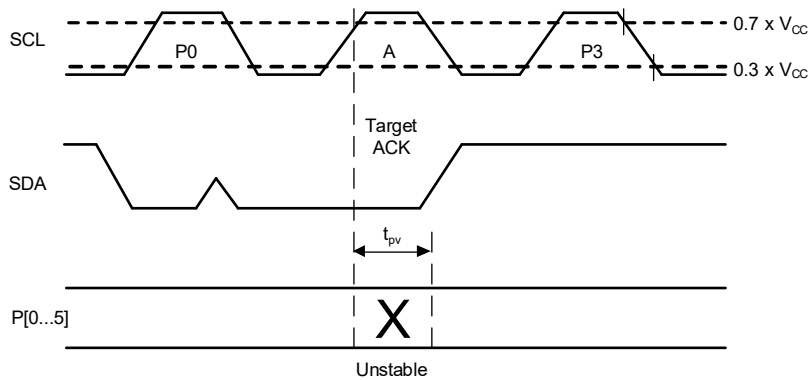

Figure 92. I²C IO Expander Output Timing

13.5 I²C Serial Communications Commands

13.5.1 Byte Write Command

Following a valid START condition from the Controller, the 7-bit Target Address and the R/W bit (set to “0”), are placed onto the I²C bus by the Controller. After the SLG46540 sends an Acknowledge bit (ACK), the next byte transmitted by the Controller is the Word Address. The Word Address (A7 through A0 set the internal address pointer in the SLG46540, where the data byte is to be written. After the SLG46540 sends another Acknowledge bit, the Controller will transmit the data byte to be written into the addressed memory location. The SLG46540

again provides an Acknowledge bit and then the Controller generates a STOP condition. A valid STOP condition is defined as a LOW to HIGH transition (rising edge) on the SDA line while the SCL is held HIGH. The internal write cycle for the data will take place at the time that the SLG46540 generates the Acknowledge bit.

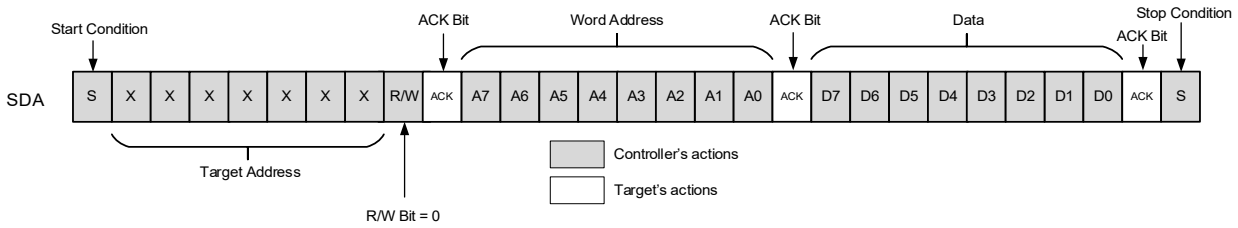

Figure 93. Byte Write Command, R/W = 0

13.5.2 Sequential Write Command

For this type of command the Target Address Word Address, and the first data byte are transmitted to the SLG46540 in the same way as in a Byte Write command. However, instead of generating a STOP condition, the Controller continues to transmit data bytes to the SLG46540. Each subsequent data byte will increment the internal address counter, and will be written into the next higher byte in the command addressing. As in the case of the Byte Write command, the internal write cycle will take place while the SLG46540 generates the Acknowledge bit.

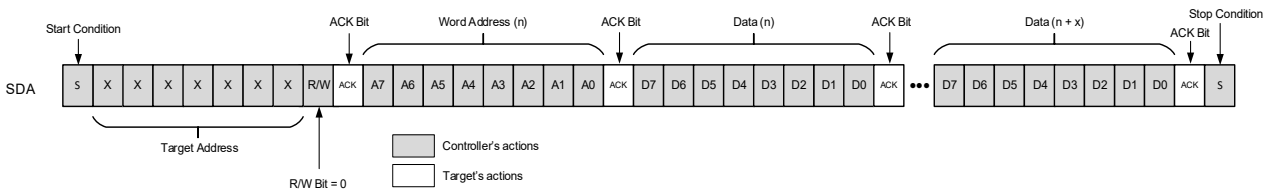

Figure 94. Sequential Write Command, R/W = 0

13.5.3 Current Address Read Command

The Current Address Read Command reads from the current pointer address location. The address pointer is incremented at the first STOP condition following any byte write command. For example, if a Sequential Read command (which contains a byte write command) reads data up to address n, the address pointer would get incremented to n + 1 upon the STOP of that command. Subsequently, a Current Address Read that follows would start reading data at n + 1. The Current Address Read Command contains the Target Address sent by the Controller with the R/W bit = "1". The SLG46540 will issue an Acknowledge bit, and then transmit eight data bits for the requested byte. The Controller will not issue an Acknowledge bit, and follow immediately with a Stop condition.

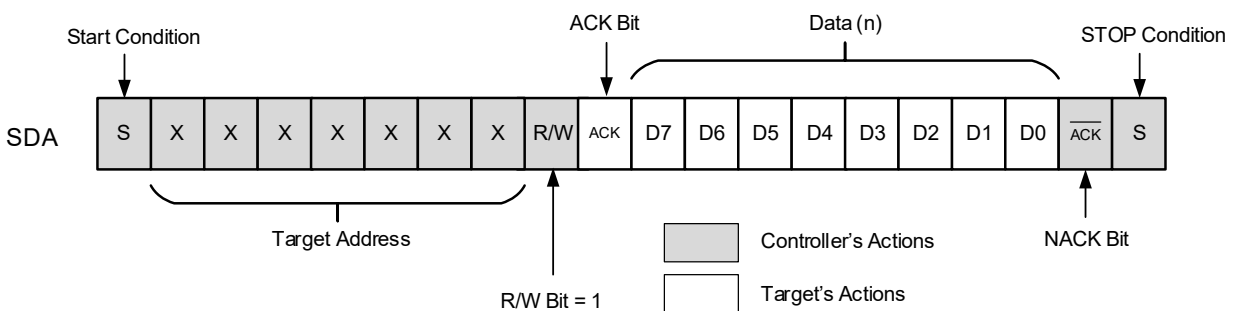

Figure 95. Current Address Read Command, R/W = 1

13.5.4 Random Read Command

The Random Read command starts with a Target Address and R/W bit set to "0", indicating a write command and a Word Address to set the internal byte address, followed by a repeated START condition and then the Target Address for the read (exactly the same as the Byte Write command). The presence of a START condition in the middle of the command will halt the decoding of a Write command and will set the internal address counter

in preparation for the second half of the command. After the repeated START condition, the Bus Controller issues a second Target Address with the R/W bit set to “1”, after which the SLG46540 issues an Acknowledge bit, followed by the requested eight data bits.

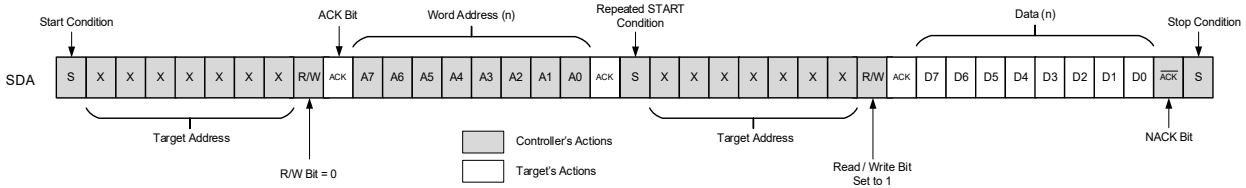

Figure 96. Random Read Command

13.5.5 Sequential Read Command

The Sequential Read command is initiated with a START condition from the Controller, then the Target Address and the R/W bit set to ‘1’. The SLG46540 then responds with the byte of data from the current pointer address. If the Controller responds with an ACK bit, then the Target sends another byte of data at the pointer address n + 1. This process continues until the Controller does not send an ACK bit and instead generates a STOP condition.

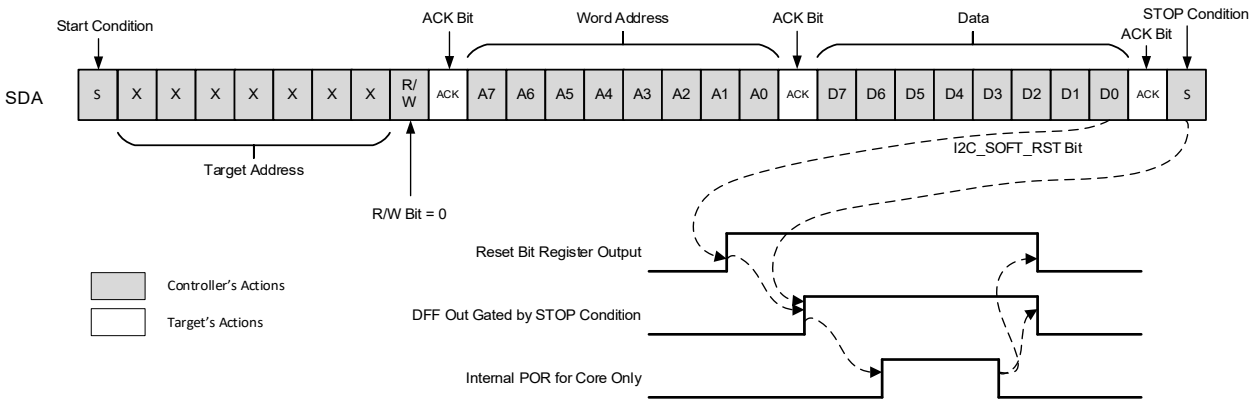

Figure 97. Sequential Read Command

13.5.6 I²C Serial Command Address Space

In the read and write command address structure, there are a total of 11 bits of addressing, each pointing to a unique byte of information, resulting in a total address space of 2K bytes. Of this 2K byte address space, the valid addresses accessible to the I²C Macrocell on the SLG46540 are in the range from 0 (0x00) to 255 (0xFF). The MSB address bits (A10, A9, and A8) will be “0” for all commands to the SLG46540.

13.5.7 I²C Serial Command Register Map

These register addresses are broken down into four Banks to give the user greater control on access to reading and writing information in each bank. Each of the four banks is 512 bits (64 bytes) in length. Writing information to register bits in these Banks will change the configuration of the device, resulting in either a change in the interconnection options provided by the Connection Matrix, or by changing the configuration of individual macrocells. During device use, all register bits can be read or written via I²C, unless protection bits are set to prevent this. Refer to Table 28. IO Expander Registers for Word Address to select the desired IO Expander Registers. See section See section 14 Register Definitions for detailed information on all register bits.

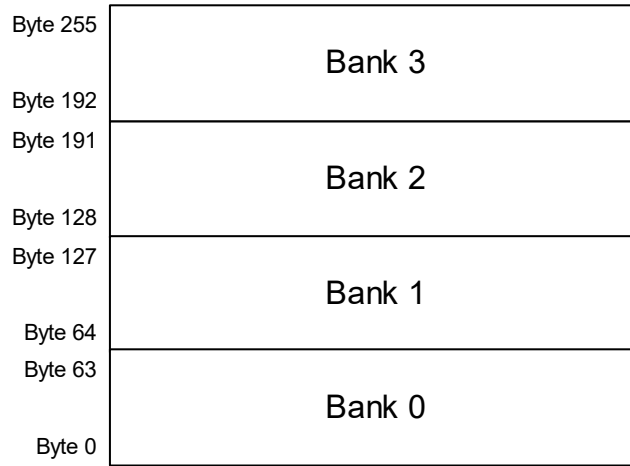

Figure 98. Register Bank Map

Table 28. IO Expander Registers

Word Address (Hex)	Register Bit Definition [7:0]	I ² C Interface	
		Read	Write
0x00	Input Port Register P3-P0 default value: 1111_XXXX Readback of input logic level of ports P3 to P0	Valid	Invalid
0x01	Output Port Register P3-P0 default value: 1111_1111 Writes to set output logic levels of ports P3 to P0	Valid	Valid
0x02	Polarity Inversion Register 0: original polarity, 1: inverted polarity P3-P0 default value: 0000_0000 Writes to enable or disable polarity inversion of ports P3 to P0	Valid	Valid
0x03	Configuration Register 0: output mode, 1: input mode P3-P0 default value: 1111_1111 Writes to configure the direction of the ports P3 to P0	Valid	Valid

13.6 I²C Serial Command Register Protection

The memory space is divided into four banks, each of which has 512bits (64bytes). There are three bits that allow the user to define rules for reading and writing bits in each of these banks via I²C:

- Reg [1832] I²C lock for read bits [1535:32] (Bank 0/1/2). If the system provides any read commands to the addresses in these three banks, the device will respond with 'FFH' in data field.
- Reg [1871] I²C lock for write bits [1535:32] (Bank 0/1/2). If the system provides any write commands to the addresses in these three banks, the device will acknowledge these commands, but will not do internal writes to the register space.
- Reg [1870] I²C lock for write all bits except bits [31:8] (Bank 0/1/2/3). If the system provides any write commands to the addresses in these four banks, the device will acknowledge these commands but will not do internal writes to the register space.

Note 1: register [1870] is higher priority than register [1871], and if register [1870] is set, than register [1871] does not have any effect.

Note 2: If the user sets Pins 8 and 9 function to a selection other than SDA and SCL, all access via I²C will be disabled.

If register [1870] is not set, register bits in Bank 3 are open to read and write commands via I²C with the following exceptions:

- Reg [1871] Bank 0/1/2 I²C write protection bit is always protected from I²C write.
- Reg [1734:1728] I²C Control Code Bit[6:0] is always protected from I²C write.

Note 3: Any write commands that come to the device via I²C that are not blocked, based on the protection bits, will change the contents of the RAM register bits that mirror the NVM bits. These write commands will not change the NVM bits themselves, and a POR event will restore the register bits to original programmed contents of the NVM.

See section [14 Register Definitions](#) for detailed information on all registers.

13.6.1 Register Read/Write Protection

There are six read/write protect modes for the design sequence from being corrupted or copied. See [Table 29](#) for details.

Table 29. Read/Write Protection Options

Bank	Byte	Bits	Description	Lock Status					
				Unlocked	Locked for Read Bits [1535:32]	Locked for Write Bits [1535:32]	Locked for Write Bits [2047:32]	Locked for Read and Write Bits [1535:32]	Locked for Read Bits [1535:32] and Write Bits [2047:32]
				Register [1832] = 0, [1871] = 0, [1870] = 0	Register [1832] = 1, [1871] = 0, [1870] = 0	Register [1832] = 0, [1871] = 1, [1870] = 0	Register [1832] = 0, [1871] = x, [1870] = 1	Register [1832] = 1, [1871] = 1, [1870] = 0	Register [1832] = 1, [1871] = x, [1870] = 1
0	0	7-0	IO Expander Configuration	R	R	R	R	R	R
0	1	11-8		R/W	R/W	R/W	R/W	R/W	R/W
0	1	15-9		R	R	R	R	R	R
0	2	19-16		R/W	R/W	R/W	R/W	R/W	R/W
0	2	23-20		R	R	R	R	R	R
0	3	27-24		R/W	R/W	R/W	R/W	R/W	R/W
0	3	31-28		R	R	R	R	R	R
0	4-63	511-32	Connection Matrix Outputs Configuration	R/W	W	R	R	-	-
1	64-109	879-512		R/W	W	R	R	-	-
	110-127	880-1023	Reserved	-	-	-	-	-	-
2	128-186	1495-1024	Function Configuration for Pins, LUTs/DFFs, OSC, and configuration for DLYs, ACMP	R/W	W	R	R	-	-
	187-191	1535-1496	Reserved	-	-	-	-	-	-

Bank	Byte	Bits	Description	Lock Status					
				Unlocked	Locked for Read Bits [1535:32]	Locked for Write Bits [1535:32]	Locked for Write Bits [2047:32]	Locked for Read and Write Bits [1535:32]	Locked for Read Bits [1535:32] and Write Bits [2047:32]
				Register [1832] = 0, [1871] = 0, [1870] = 0	Register [1832] = 1, [1871] = 0, [1870] = 0	Register [1832] = 0, [1871] = 1, [1870] = 0	Register [1832] = 0, [1871] = x, [1870] = 1	Register [1832] = 1, [1871] = 1, [1870] = 0	Register [1832] = 1, [1871] = x, [1870] = 1
3	192-206	1655-1536	CNT/DLY counter data and some LUTs truth table, ACMP V _{REF}	R/W	R/W	R/W	R	R/W	R
	207	1663	IO Latching Enable During I ² C Write Interface	R	R	R	R	R	R
		1662	I ² C reset bit with reloading NVM into Data register	R/W	R/W	R/W	R	R/W	R
		1661-1659, 1663	Reserved	R	R	R	R	R	R
		1658-1656	OSC Power Control	R/W	R/W	R/W	R	R/W	R
	208-215	1727-1664	Reserved	R/W	R/W	R/W	R	R/W	R
	216	1735-1728	I ² C Control code	R	R	R	R	R	R
	217-218	1751-1736	Reserved	-	-	-	-	-	-
	219-223	1791-1752	User configurable RAM	R/W	R/W	R/W	R	R/W	R
	224-227	1823-1792	Reserved	-	-	-	-	-	-
	228	1831-1824	Reserved	R/W	R/W	R/W	R	R/W	R
	229	1839-1836	Product Family ID	R	R	R	R	R	R
		1835-1834	Reserved	-	-	-	-	-	-
		1833	Reserved	R	R	R	R	R	R
		1832	I ² C Lock for read bits [1535:32]	R	R	R	R	R	R
	230	1847-1840	Pattern ID	R/W	R/W	R/W	R	R/W	R
	231	1855-1848	Reserved	R	R	R	R	R	R
	232	1863-1856	Reserved	R	R	R	R	R	R
	233	1871	I ² C Lock for write bits [1535:32]	R	R	R	R	R	R
		1870	I ² C Lock for write all bits [2047:32]	R	R	R	R	R	R
		1869-1868	Reserved	-	-	-	-	-	-
		1867-1864	I ² C Control Code	R	R	R	R	R	R
	234-239	1919-1872	Counter Current Value	R	R	R	R	R	R
	240-243	1951-1920	Macrocells Output Values (Connection Matrix Inputs)	R	R	R	R	R	R
	244	1959-1952	Reserved	-	-	-	-	-	-
	245	1967-1960	Macrocells Output Values (Connection Matrix Inputs)	R	R	R	R	R	R
	246	1975-1968	Reserved	-	-	-	-	-	-
	247	1983-1976	Macrocells Output Values (Connection Matrix Inputs)	R	R	R	R	R	R
	248-250	2007-1984	Reserved	R	R	R	R	R	R

Bank	Byte	Bits	Description	Lock Status					
				Unlocked	Locked for Read Bits [1535:32]	Locked for Write Bits [1535:32]	Locked for Write Bits [2047:32]	Locked for Read and Write Bits [1535:32]	Locked for Read Bits [1535:32] and Write Bits [2047:32]
				Register [1832] = 0, [1871] = 0, [1870] = 0	Register [1832] = 1, [1871] = 0, [1870] = 0	Register [1832] = 0, [1871] = 1, [1870] = 0	Register [1832] = 0, [1871] = x, [1870] = 1	Register [1832] = 1, [1871] = 1, [1870] = 0	Register [1832] = 1, [1871] = x, [1870] = 1
3	251	2015-2008	Reserved	R/W	R/W	R/W	R	R/W	R
	252-253	2031-2016	Reserved	R	R	R	R	R	R
	254	2039-2032	Reserved	R/W	R/W	R/W	R	R/W	R
	255	2047-2040	Reserved	R/W	R/W	R/W	R	R/W	R

R/W	Allow Read and Write Data
W	Allow Write Data Only
R	Allow Read Data Only
-	The Data is protected for Read and Write

13.6.2 I²C Serial Reset Command

Once I²C serial communication is established with the device, it is possible to reset the device to initial power up conditions, including configuration of all macrocells, and all connections provided by the Connection Matrix. This is implemented by setting register [1662] I²C reset bit to “1”, which causes the device to re-enable the Power-On Reset (POR) sequence, including the reload of all register data from NVM. During the POR sequence, the outputs of the device will be in tri-state. After the reset has completed, the contents of register [1662] will be set to “0” automatically. Figure 99 illustrates the sequence of events for this reset function.

Note: I²C Serial Reset Command is not available during emulation.

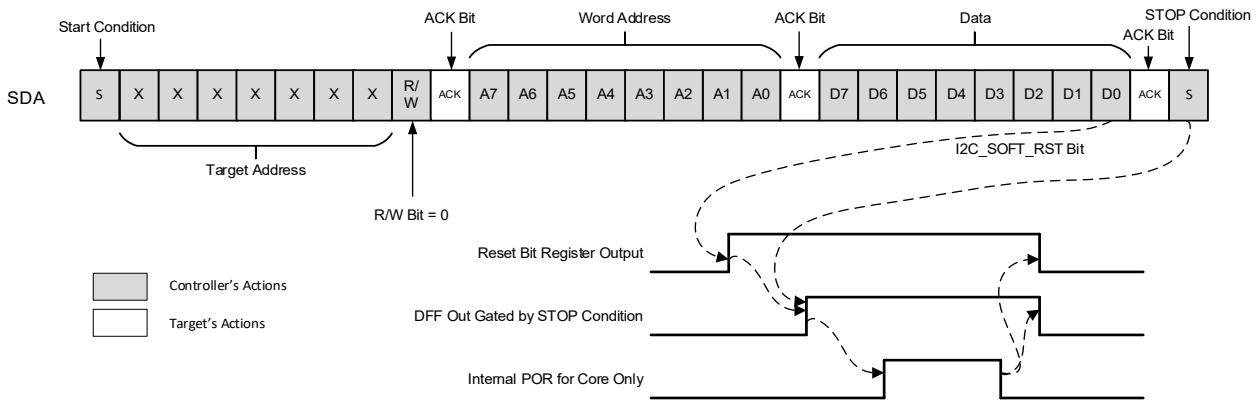

Figure 99. Serial Reset Command Timing

13.7 I²C Additional Options

13.7.1 Reading Counter Data via I²C

The current count value in four counters in the device can be read via I²C. The counters that have this additional functionality are 16-bit CNT0 and CNT1, and 8-bit counters CNT4 and CNT6.

13.7.2 User RAM and OTP Memory Array

There are eight bytes of RAM memory that can be read and written remotely by I²C commands. The initial contents of this memory space can be selected by the user, and this information will be transferred from OTP memory to the RAM memory space during the power-up sequence. The lowest order byte in this array (User Configurable RAM/OTP Byte 3) is located at I²C address 0xDB, and the highest order byte in this array is located at I²C address 0xDF.

Table 30. RAM Array Table

2C Address (hex)	Highest Bit Address	Lowest Bit Address	Memory Byte
D9	1743	1736	Reserved
DA	1751	1744	Reserved
DB	1759	1752	User Configurable RAM/OTP Byte 3
DC	1767	1760	User Configurable RAM/OTP Byte 4
DD	1775	1768	User Configurable RAM/OTP Byte 5
DE	1783	1776	User Configurable RAM/OTP Byte 6
DF	1791	1784	User Configurable RAM/OTP Byte 7

14. Register Definitions

14.1 Register Map

Table 31. Register Map

Address		Signal Function	Register Bit Definition	I ² C Interface	
Byte	Register Bit			Read	Write
Note: For register [0] to register [1495], I ² C Read is valid (assuming register [1832] = 0), I ² C Write is valid (assuming register [1871] = 0).					
Matrix 64-to-1 MUX's 6 Selection Bits					
00	7:0	Matrix OUT	Input Port Register P3-P0 default value: 1111_XXXX	Valid	Invalid
01	15:8	Matrix OUT	Output Port Register P3-P0 default value: 1111_1111	Valid	Valid
02	23:16	Matrix OUT	Polarity Inversion Register 0: original polarity, 1: inverted polarity P3-P0 default value: 0000_0000	Valid	Valid
03	31:24	Matrix OUT	Configuration Register 0: output mode, 1: input mode P3-P0 default value: 1111_1111	Valid	Valid
04	39:32	Reserved		Valid	Valid
05	47:40	Reserved		Valid	Valid
06	55:48	Reserved		Valid	Valid
07	63:56	Reserved		Valid	Valid
08	71:64	Reserved		Valid	Valid
09	79:72	Reserved		Valid	Valid
0A	87:80	Reserved		Valid	Valid
0B	95:88	Reserved		Valid	Valid
0C	103:96	Reserved		Valid	Valid
0D	111:104	Reserved		Valid	Valid
0E	119:112	Reserved		Valid	Valid
0F	127:120	Reserved		Valid	Valid
10	135:128	Reserved		Valid	Valid
11	143:136	Reserved		Valid	Valid
12	151:144	Reserved		Valid	Valid
13	159:152	Reserved		Valid	Valid
14	167:160	Reserved		Valid	Valid
15	175:168	Reserved		Valid	Valid
16	183:176	Reserved		Valid	Valid
17	191:184	Reserved		Valid	Valid
18	199:192	Reserved		Valid	Valid

Address		Signal Function	Register Bit Definition	I ² C Interface	
Byte	Register Bit			Read	Write
19	205:200	Reserved		Valid	Valid
	207:206	Reserved		Valid	Valid
1A	213:208	Reserved		Valid	Valid
	215:214	Reserved		Valid	Valid
1B	221:216	Matrix OUT	Pin 3 Digital Output Source	Valid	Valid
	223:222	Reserved		Valid	Valid
1C	229:224	Reserved		Valid	Valid
	231:230	Reserved		Valid	Valid
1D	237:232	Reserved		Valid	Valid
	239:238	Reserved		Valid	Valid
1E	245:240	Matrix OUT	Pin 4 Digital Output Source	Valid	Valid
	247:246	Reserved		Valid	Valid
1F	253:248	Matrix OUT	Pin 5 Digital Output Source	Valid	Valid
	255:254	Reserved		Valid	Valid
20	261:256	Matrix OUT	Pin 5 Output Enable	Valid	Valid
	263:262	Reserved		Valid	Valid
21	269:264	Matrix OUT	Pin 6 Digital Output Source (SCL with VI/Input and NMOS Open-Drain)	Valid	Valid
	271:270	Reserved		Valid	Valid
22	277:272	Matrix OUT	Pin 7 Digital Output Source (SDA with VI/Input and NMOS Open-Drain)	Valid	Valid
	279:278	Reserved		Valid	Valid
23	285:280	Matrix OUT	Pin 8 Digital Output Source	Valid	Valid
	287:286	Reserved		Valid	Valid
24	293:288	Matrix OUT	Pin 8 Output Enable	Valid	Valid
	295:294	Reserved		Valid	Valid
25	301:296	Matrix OUT	Pin 10 Digital Output Source	Valid	Valid
	303:302	Reserved		Valid	Valid
26	309:304	Reserved		Valid	Valid
	311:310	Reserved		Valid	Valid
27	317:312	Matrix OUT	Pin 10 Output Enable	Valid	Valid
	319:318	Reserved		Valid	Valid
28	325:320	Matrix OUT	Pin 11 Digital Output Source	Valid	Valid
	327:326	Reserved		Valid	Valid
29	333:328	Reserved	Pin 11 Output Enable	Valid	Valid
	335:334	Reserved		Valid	Valid

Address		Signal Function	Register Bit Definition	I ² C Interface	
Byte	Register Bit			Read	Write
2A	341:336	Reserved		Valid	Valid
	343:342	Reserved		Valid	Valid
2B	349:344	Matrix OUT	Pin 12 Digital Output Source	Valid	Valid
	351:350	Reserved		Valid	Valid
2C	357:352	Matrix OUT	Pin 12 Output Enable	Valid	Valid
	359:358	Reserved		Valid	Valid
2D	365:360	Matrix OUT	Pin 13 Digital Output Source	Valid	Valid
	367:366	Reserved		Valid	Valid
2E	373:368	Reserved		Valid	Valid
	375:374	Reserved		Valid	Valid
2F	381:376	Reserved		Valid	Valid
	383:382	Reserved		Valid	Valid
30	389:384	Reserved		Valid	Valid
	391:390	Reserved		Valid	Valid
31	397:392	Matrix OUT	Pin 14 Output Enable	Valid	Valid
	399:398	Reserved		Valid	Valid
32	405:400	Matrix OUT	Pin 14 Digital Output Source	Valid	Valid
	407:406	Reserved		Valid	Valid
33	413:408	Matrix OUT	ACMP0 nPD (Power-Down)	Valid	Valid
	415:414	Reserved		Valid	Valid
34	421:416	Matrix OUT	ACMP1 nPD (Power-Down)	Valid	Valid
	423:422	Reserved		Valid	Valid
35	429:424	Matrix OUT	ACMP2 nPD (Power-Down)	Valid	Valid
	431:430	Reserved		Valid	Valid
36	437:432	Reserved		Valid	Valid
	439:438	Reserved		Valid	Valid
37	445:440	Matrix OUT	Input of Filter_0 with fixed time edge detector	Valid	Valid
	447:446	Reserved		Valid	Valid
38	453:448	Matrix OUT	Input of Filter_1 with fixed time edge detector	Valid	Valid
	455:454	Reserved		Valid	Valid
39	461:456	Matrix OUT	Input of Programmable Delay and Edge Detector	Valid	Valid
	463:462	Reserved		Valid	Valid

Address		Signal Function	Register Bit Definition	I ² C Interface	
Byte	Register Bit			Read	Write
3A	469:464	Matrix OUT	OSC 25 kHz/2 MHz nPD (Power-Down)	Valid	Valid
	471:470	Reserved		Valid	Valid
3B	477:472	Matrix OUT	OSC 25 MHz nPD (Power-Down)	Valid	Valid
	479:478	Reserved		Valid	Valid
3C	485:480	Matrix OUT	IN0 of 2-bit LUT0 or Clock Input of DFF0	Valid	Valid
	487:486	Reserved		Valid	Valid
3D	493:488	Matrix OUT	IN1 of 2-bit LUT0 or Data Input of DFF0	Valid	Valid
	495:494	Reserved		Valid	Valid
3E	501:496	Matrix OUT	IN0 of 2-bit LUT1 or Clock Input of DFF1	Valid	Valid
	503:502	Reserved		Valid	Valid
3F	509:504	Matrix OUT	IN1 of 2-bit LUT1 or Data Input of DFF1	Valid	Valid
	511:510	Reserved		Valid	Valid
40	517:512	Matrix OUT	IN0 of 2-bit LUT2 or Clock Input of DFF2	Valid	Valid
	519:518	Reserved		Valid	Valid
41	525:520	Matrix OUT	IN1 of 2-bit LUT2 or Data Input of DFF2	Valid	Valid
	527:526	Reserved		Valid	Valid
42	533:528	Matrix OUT	IN0 of 2-bit LUT3 or Clock Input of PGen	Valid	Valid
	535:534	Reserved		Valid	Valid
43	541:536	Matrix OUT	IN1 of 2-bit LUT3 or nRST of PGen	Valid	Valid
	543:542	Reserved		Valid	Valid
44	549:544	Matrix OUT	IN0 of 3-bit LUT0 or Clock Input of DFF3	Valid	Valid
	551:550	Reserved		Valid	Valid
45	557:552	Matrix OUT	IN1 of 3-bit LUT0 or Data Input of DFF3	Valid	Valid
	559:558	Reserved		Valid	Valid
46	565:560	Matrix OUT	IN2 of 3-bit LUT0 or nRST (nSET) of DFF3	Valid	Valid
	567:566	Reserved		Valid	Valid
47	573:568	Matrix OUT	IN0 of 3-bit LUT1 or Clock Input of DFF4	Valid	Valid
	575:574	Reserved		Valid	Valid
48	581:576	Matrix OUT	IN1 of 3-bit LUT1 or Data Input of DFF4	Valid	Valid
	583:582	Reserved		Valid	Valid
49	589:584	Matrix OUT	IN2 of 3-bit LUT1 or nRST (nSET) of DFF4	Valid	Valid
	591:590	Reserved		Valid	Valid
4A	597:592	Matrix OUT	IN0 of 3-bit LUT2 or Clock Input of DFF5	Valid	Valid
	599:598	Reserved		Valid	Valid

Address		Signal Function	Register Bit Definition	I ² C Interface	
Byte	Register Bit			Read	Write
4B	605:600	Matrix OUT	IN1 of 3-bit LUT2 or Data Input of DFF5	Valid	Valid
	607:606	Reserved		Valid	Valid
4C	613:608	Matrix OUT	IN2 of 3-bit LUT2 or nRST (nSET) of DFF5	Valid	Valid
	615:614	Reserved		Valid	Valid
4D	621:616	Matrix OUT	IN0 of 3-bit LUT3 or Clock Input of DFF6	Valid	Valid
	623:622	Reserved		Valid	Valid
4E	629:624	Matrix OUT	IN1 of 3-bit LUT3 or Data Input of DFF6	Valid	Valid
	631:630	Reserved		Valid	Valid
4F	637:632	Matrix OUT	IN2 of 3-bit LUT3 or nRST (nSET) of DFF6	Valid	Valid
	639:638	Reserved		Valid	Valid
50	645:640	Matrix OUT	IN0 of 3-bit LUT4 or Clock Input of DFF7	Valid	Valid
	647:646	Reserved		Valid	Valid
51	653:648	Matrix OUT	IN1 of 3-bit LUT4 or Data Input of DFF7	Valid	Valid
	655:654	Reserved		Valid	Valid
52	661:656	Matrix OUT	IN2 of 3-bit LUT4 or nRST (nSET) of DFF7	Valid	Valid
	663:662	Reserved		Valid	Valid
53	669:664	Matrix OUT	IN0 of 3-bit LUT5 or Delay2 Input (or Counter2 RST Input)	Valid	Valid
	671:670	Reserved		Valid	Valid
54	677:672	Matrix OUT	IN1 of 3-bit LUT5 or External Clock Input of Delay2 (or Counter2)	Valid	Valid
	679:678	Reserved		Valid	Valid
55	685:680	Matrix OUT	IN2 of 3-bit LUT5	Valid	Valid
	687:686	Reserved		Valid	Valid
56	693:688	Matrix OUT	IN0 of 3-bit LUT6 or Delay3 Input (or Counter3 RST Input)	Valid	Valid
	695:694	Reserved		Valid	Valid
57	701:696	Matrix OUT	IN1 of 3-bit LUT6 or External Clock Input of Delay3 (or Counter3)	Valid	Valid
	703:702	Reserved		Valid	Valid
58	709:704	Matrix OUT	IN2 of 3-bit LUT6	Valid	Valid
	711:710	Reserved		Valid	Valid
59	717:712	Matrix OUT	IN0 of 3-bit LUT7 or Delay4 Input (or Counter4 RST Input)	Valid	Valid
	719:718	Reserved		Valid	Valid
5A	725:720	Matrix OUT	IN1 of 3-bit LUT7 or External Clock Input of Delay4 (or Counter4)	Valid	Valid
	727:726	Reserved		Valid	Valid

Address		Signal Function	Register Bit Definition	I ² C Interface	
Byte	Register Bit			Read	Write
5B	733:728	Matrix OUT	IN2 of 3-bit LUT7	Valid	Valid
	735:734	Reserved		Valid	Valid
5C	741:736	Matrix OUT	IN0 of 3-bit LUT8 or Delay5 Input (or Counter5 RST Input)	Valid	Valid
	743:742	Reserved		Valid	Valid
5D	749:744	Matrix OUT	IN1 of 3-bit LUT8 or External Clock Input of Delay5 (or Counter5)	Valid	Valid
	751:750	Reserved		Valid	Valid
5E	757:752	Matrix OUT	IN2 of 3-bit LUT8	Valid	Valid
	759:758	Reserved		Valid	Valid
5F	765:760	Matrix OUT	IN0 of 3-bit LUT9 or Delay6 Input (or Counter6 RST Input)	Valid	Valid
	767:766	Reserved		Valid	Valid
60	773:768	Matrix OUT	IN1 of 3-bit LUT9 or External Clock Input of Delay6 (or Counter6)	Valid	Valid
	775:774	Reserved		Valid	Valid
61	781:776	Matrix OUT	IN2 of 3-bit LUT9	Valid	Valid
	783:782	Reserved		Valid	Valid
62	789:784	Matrix OUT	IN0 of 3-bit LUT10 or Input of Pipe Delay	Valid	Valid
	791:790	Reserved		Valid	Valid
63	797:792	Matrix OUT	IN1 of 3-bit LUT10 or nRST of Pipe Delay	Valid	Valid
	799:798	Reserved		Valid	Valid
64	805:800	Matrix OUT	IN2 of 3-bit LUT10 or Clock of Pipe Delay	Valid	Valid
	807:806	Reserved		Valid	Valid
65	813:808	Matrix OUT	IN0 of 4-bit LUT0 or Delay0 Input (or Counter0 RST/SET Input)	Valid	Valid
	815:814	Reserved		Valid	Valid
66	821:816	Matrix OUT	IN1 of 4-bit LUT0 or External Clock Input of Delay0 (or Counter0)	Valid	Valid
	823:822	Reserved		Valid	Valid
67	829:824	Matrix OUT	IN2 of 4-bit LUT0 or UP Input of FSM0	Valid	Valid
	831:830	Reserved		Valid	Valid
68	837:832	Matrix OUT	IN3 of 4-bit LUT0 or KEEP Input of FSM0	Valid	Valid
	839:838	Reserved		Valid	Valid
69	845:840	Matrix OUT	IN0 of 4-bit LUT1 or Delay1 Input (or Counter1 RST/SET Input)	Valid	Valid
	847:846	Reserved		Valid	Valid

Address		Signal Function	Register Bit Definition	I ² C Interface	
Byte	Register Bit			Read	Write
6A	853:848	Matrix OUT	IN1 of 4-bit LUT1 or External Clock Input of Delay1 (or Counter1)	Valid	Valid
	855:854	Reserved		Valid	Valid
6B	861:856	Matrix OUT	IN2 of 4-bit LUT1 or UP Input of FSM1	Valid	Valid
	863:862	Reserved		Valid	Valid
6C	869:864	Matrix OUT	IN3 of 4-bit LUT1 or KEEP Input of FSM1	Valid	Valid
	871:870	Reserved		Valid	Valid
6D	877:872	Reserved		Valid	Valid
	879:878	Reserved		Valid	Valid
6E	887:880	Reserved		Invalid	Invalid
6F	895:888	Reserved		Invalid	Invalid
70	903:896	Reserved		Invalid	Invalid
71	911:904	Reserved		Invalid	Invalid
72	919:912	Reserved		Invalid	Invalid
73	927:920	Reserved		Invalid	Invalid
74	935:928	Reserved		Invalid	Invalid
75	943:936	Reserved		Invalid	Invalid
76	951:944	Reserved		Invalid	Invalid
77	959:952	Reserved		Invalid	Invalid
78	967:960	Reserved		Invalid	Invalid
79	975:968	Reserved		Invalid	Invalid
7A	983:976	Reserved		Invalid	Invalid
7B	991:984	Reserved		Invalid	Invalid
7C	999:992	Reserved		Invalid	Invalid
7D	1007:1000	Reserved		Invalid	Invalid
7E	1015:1008	Reserved		Invalid	Invalid
7F	1023:1016	Reserved		Invalid	Invalid

Address		Signal Function	Register Bit Definition	I ² C Interface	
Byte	Register Bit			Read	Write
Pin 2					
80	1024	Reserved		Valid	Valid
	1025	Reserved		Valid	Valid
	1027:1026	Reserved		Valid	Valid
	1029:1028	Pin 2 Pull Down Resistor Value Selection	00: Floating 01: 10 k 10: 100 k 11: 1 M	Valid	Valid
	1031:1030	Pin 2 Mode Control	00: Digital Input without Schmitt Trigger 01: Digital Input with Schmitt Trigger 10: Low Voltage Digital Input 11: Reserved	Valid	Valid
	1032	Reserved		Valid	Valid
81	1039:1033	Reserved		Valid	Valid
Pin 3					
82	1040	Reserved		Valid	Valid
	1041	Pin 3 Driver Strength Selection	0: 1x 1: 2x	Valid	Valid
	1042	Pin 3 Pull-up/down Resistor Selection	0: Pull-down Resistor 1: Pull-up Resistor	Valid	Valid
	1044:1043	Pin 3 Pull-up/down Resistor Value Selection	00: Floating 01: 10 k 10: 100 k 11: 1 M	Valid	Valid
	1047:1045	Pin 3 Mode Control	000: Digital Input without Schmitt Trigger 001: Digital Input with Schmitt Trigger 010: Low Voltage Digital Input 011: Reserved 100: Push-Pull 101: Open-Drain NMOS 110: Open-Drain PMOS 111: Reserved	Valid	Valid
83	1055:1048			Valid	Valid

Address		Signal Function	Register Bit Definition	I ² C Interface	
Byte	Register Bit			Read	Write
Pin 4					
84	1056	Reserved		Valid	Valid
	1057	Pin 4 Driver Strength Selection	0: 1x 1: 2x	Valid	Valid
	1058	Pin 4 Pull-up/down Resistor Selection	0: Pull-down Resistor 1: Pull-up Resistor	Valid	Valid
	1060:1059	Pin 4 Pull-up/down Resistor Value Selection	00: Floating 01: 10 k 10: 100 k 11: 1 M	Valid	Valid
	1063:1061	Pin 4 Mode Control	000: Digital Input without Schmitt Trigger 001: Digital Input with Schmitt Trigger 010: Low Voltage Digital Input 011: Analog Input/Output 100: Push-Pull 101: Open-Drain NMOS 110: Open-Drain PMOS 111: Analog Input and Open-Drain	Valid	Valid
Pin 5					
85	1064	Reserved		Valid	Valid
	1065	Pin 5 Pull-up/down Resistor Selection	0: Pull-down Resistor 1: Pull-up Resistor	Valid	Valid
	1067:1066	Pin 5 Pull-up/down Resistor Value Selection	00: Floating 01: 10 k 10: 100 k 11: 1 M	Valid	Valid
	1069:1068	Pin 5 Mode Control (sig_io5_oe = 0)	00: Digital Input without Schmitt Trigger 01: Digital Input with Schmitt Trigger 10: Low Voltage Digital Input 11: Analog Input/Output	Valid	Valid
	1071:1070	Pin 5 Mode Control (sig_io5_oe = 1)	00: Push-Pull 1x 01: Push-Pull 2x 10: Open-Drain NMOS 1x 11: Open-Drain NMOS 2x	Valid	Valid

Address		Signal Function	Register Bit Definition	I ² C Interface	
Byte	Register Bit			Read	Write
Pin 6					
86	1072	Reserved		Valid	Valid
	1073	Pin 6 Driver Strength Selection	0: 1x 1: 2x	Valid	Valid
	1074	Select SCL and Virtual Input 0 or Pin 6	0: SCL and Virtual Input 0 1: Pin 6	Valid	Valid
	1076:1075	Pin 6 Pull-down Resistor Value Selection	00: Floating 01: 10 k 10: 100 k 11: 1 M	Valid	Valid
	1079:1077	Pin 6 (or SCL) Mode Control (input mode is selected by register at SCL)	000: Digital Input without Schmitt Trigger 001: Digital Input with Schmitt Trigger 010: Low Voltage Digital Input 011: Reserved 100: Reserved 101: Open-Drain NMOS 110: Reserved 111: Reserved	Valid	Valid
Pin 7					
87	1080	Reserved		Valid	Valid
	1081	Pin 7 (or SDA) Driver Strength Selection	0: 1x 1: 2x	Valid	Valid
	1082	Select SDA and Virtual Input 1 or Pin 7	0: SDA and Virtual Input 1 1: Pin 7	Valid	Valid
	1084:1083	Pin 7 Pull-down Resistor Value Selection	00: Floating 01: 10 k 10: 100 k 11: 1 M	Valid	Valid
	1087:1085	Pin 7 (or SDA) Mode Control (input mode is selected by register at SDA, output mode is fixed as OD at SDA)	000: Digital Input without Schmitt Trigger 001: Digital Input with Schmitt Trigger 010: Low Voltage Digital Input 011: Reserved 100: Reserved 101: Open-Drain NMOS 110: Reserved 111: Reserved	Valid	Valid

Address		Signal Function	Register Bit Definition	I ² C Interface	
Byte	Register Bit			Read	Write
Pin 8					
88	1088	Pin 8 Super Drive (4x, NMOS Open-Drain) Selection	0: Super Drive OFF 1: Super Drive ON (if sig_io8_oeb = '0' and Pin 8 Mode Control = '1x')	Valid	Valid
	1089	Pin 8 Pull-up/down Resistor Selection	0: Pull-down Resistor 1: Pull-up Resistor	Valid	Valid
	1091:1090	Pin 8 Pull-up/down Resistor Value Selection	00: Floating 01: 10 k 10: 100 k 11: 1 M	Valid	Valid
	1093:1092	Pin 8 Mode Control (sig_io8_oeb = 1)	XX: Digital Input with Schmitt Trigger	Valid	Valid
	1095:1094	Pin 8 Mode Control (sig_io8_oeb = 0)	00: Push-Pull 1x 01: Push-Pull 2x 10: Open-Drain NMOS 1x 11: Open-Drain NMOS 2x	Valid	Valid
Pin 10					
89	1096	Pin 10 Super Drive (4x, NMOS Open-Drain) Selection	0: Super Drive OFF 1: Super Drive ON (if sig_io10_oeb=0 and Pin 10 Output Mode Control=1)	Valid	Valid
	1097	Pin 10 Driver Strength Selection	0: 1x 1: 2x	Valid	Valid
	1098	Pin 10 Pull-up/down Resistor Selection	0: Pull-down Resistor 1: Pull-up Resistor	Valid	Valid
	1100:1099	Pin 10 Pull-up/down Resistor Value Selection	00: Floating 01: 10 k 10: 100 k 11: 1 M	Valid	Valid
	1103	Pin 10 Output Mode Control(sig_io10_oeb=0)	0: Push-pull 1: Open Drain NMOS	Valid	Valid
	1102:1101	Pin 10 Input Mode Control(sig_io10_oeb=1)	XX : Digital Input with Schmitt Trigger	Valid	Valid
8A	1111:1104	Reserved		Valid	Valid

Address		Signal Function	Register Bit Definition	I ² C Interface	
Byte	Register Bit			Read	Write
Pin 11					
8B	1112	Reserved		Valid	Valid
	1113	Pin 11 Pull-up/down Resistor Selection	0: Pull-down Resistor 1: Pull-up Resistor	Valid	Valid
	1115:1114	Pin 11 Pull-up/down Resistor Value Selection	00: Floating 01: 10 k 10: 100 k 11: 1 M	Valid	Valid
	1117:1116	Pin 11 Mode Control (sig_io11_oeb = 1)	XX: Digital Input with Schmitt Trigger	Valid	Valid
	1119:1118	Pin 11 Mode Control (sig_io11_oeb = 0)	00: Push-Pull 1x 01: Push-Pull 2x 10: Reserved 11: Reserved	Valid	Valid
8C	1127:1120	Reserved		Valid	Valid
Pin 12					
8D	1128	Reserved		Valid	Valid
	1129	Pin 12 Pull-up/down Resistor Selection	0: Pull-down Resistor 1: Pull-up Resistor	Valid	Valid
	1131:1130	Pin 12 Pull-up/down Resistor Value Selection	00: Floating 01: 10 k 10: 100 k 11: 1 M	Valid	Valid
	1133:1132	Pin 12 Mode Control (sig_io12_oeb = 1)	XX: Digital Input with Schmitt Trigger	Valid	Valid
	1135:1134	Pin 12 Mode Control (sig_io12_oeb = 0)	00: Push-Pull 1x 01: Push-Pull 2x 10: Open-Drain NMOS 1x 11: Open-Drain NMOS 2x	Valid	Valid
Pin 13					
8E	1136	Reserved		Valid	Valid
	1137	Pin 13 Driver Strength Selection	0: 1x 1: 2x	Valid	Valid
	1138	Pin 13 Pull-up/down Resistor Selection	0: Pull-down Resistor 1: Pull-up Resistor	Valid	Valid

Address		Signal Function	Register Bit Definition	I ² C Interface	
Byte	Register Bit			Read	Write
8E	1140:1139	Pin 13 Pull-up/down Resistor Value Selection	00: Floating 01: 10 k 10: 100 k 11: 1 M	Valid	Valid
	1143:1141	Pin 13 Mode Control	000: Digital Input without Schmitt Trigger 001: Digital Input with Schmitt Trigger 010: Low Voltage Digital Input 011: Reserved 100: Push-Pull 101: Open-Drain NMOS 110: Open-Drain PMOS 111: Reserved	Valid	Valid
8F	1151:1144	Reserved		Valid	Valid
90	1159:1152	Reserved		Valid	Valid
Pin 14					
91	1160	Reserved		Valid	Valid
	1161	Pin 14 Driver Strength Selection	0: 1x 1: 2x	Valid	Valid
	1162	Pin 14 Pull-up/down Resistor Selection	0: Pull-down Resistor 1: Pull-up Resistor	Valid	Valid
	1164:1163	Pin 14 Pull-up/down Resistor Value Selection	00: Floating 01: 10 k 10: 100 k 11: 1 M	Valid	Valid
	1167	Pin 14 Output Mode Control(sig_io14_oe=1)	0: Push-pull 1: Open Drain NMOS	Valid	Valid
	1166:1165	Pin 14 Input Mode Control(sig_io14_oe=0)	00: Digital Input without Schmitt Trigger 01 : Digital Input with Schmitt Trigger 10: Low Voltage Digital Input 11 : Analog Input/Output	Valid	Valid
ACMP1					
92	1168	ACMP1 Positive Input Source Select	0: Reserved 1: ACMP0 IN+ source	Valid	Valid
	1169	Reserved		Valid	Valid
	1171:1170	ACMP1 Hysteresis Enable	00: 0 mV 01: 25 mV 10: 50 mV 11: 200 mV	Valid	Valid

Address		Signal Function	Register Bit Definition	I ² C Interface	
Byte	Register Bit			Read	Write
ACMP0					
92	1172	ACMP0 Positive Input Source Select	0: Pin 4 1: V _{DD}	Valid	Valid
	1173	ACMP0 Analog Buffer Enable (Max BW 1 MHz)	0: Disable analog buffer 1: Enable analog buffer	Valid	Valid
	1175:1174	ACMP0 Hysteresis Enable	00: 0 mV 01: 25 mV 10: 50 mV 11: 200 mV	Valid	Valid
93	1179:1176	Reserved		Valid	Valid
ACMP2					
93	1180	Reserved		Valid	Valid
	1182:1181	ACMP2 Hysteresis Enable	00: 0 mV 01: 25 mV 10: 50 mV 11: 200 mV	Valid	Valid
ACMP1 100 μA Current Source Enable					
93	1183	ACMP1 100 μA Current Source Enable	0: Disable 1: Enable	Valid	Valid
3-bit LUTx Function Select					
94	1184	3-bit LUT3 or DFF6 with nRST/nSET Select	0: 3-bit LUT3 1: DFF6 with nRST/nSET	Valid	Valid
	1185	3-bit LUT2 or DFF5 with nRST/nSET Select	0: 3-bit LUT2 1: DFF5 with nRST/nSET	Valid	Valid
	1186	3-bit LUT1 or DFF4 with nRST/nSET Select	0: 3-bit LUT1 1: DFF4 with nRST/nSET	Valid	Valid
	1187	3-bit LUT0 or DFF3 with nRST/nSET Select	0: 3-bit LUT0 1: DFF3 with nRST/nSET	Valid	Valid
2-bit LUTx Function Select					
94	1188	2-bit LUT3 or PGen Select	0: 2-bit LUT3 1: PGen	Valid	Valid
	1189	2-bit LUT2 or DFF2 Select	0: 2-bit LUT2 1: DFF2	Valid	Valid
	1190	2-bit LUT1 or DFF1 Select	0: 2-bit LUT1 1: DFF1	Valid	Valid
	1191	2-bit LUT0 or DFF0 Select	0: 2-bit LUT0 1: DFF0	Valid	Valid

Address		Signal Function	Register Bit Definition	I ² C Interface	
Byte	Register Bit			Read	Write
4-bit LUTx Function Select					
95	1192	4-bit LUT1 or DLY/CNT1(16bits) Select	0: 4-bit LUT1 1: DLY/CNT1(16bits)	Valid	Valid
	1193	4-bit LUT0 or DLY/CNT0(16bits) Select	0: 4-bit LUT0 1: DLY/CNT0(16bits)	Valid	Valid
3-bit LUTx Function Select					
95	1194	3-bit LUT9 or DLY/CNT6(8bits) Select	0: 3-bit LUT9 1: DLY/CNT6(8bits)	Valid	Valid
	1195	3-bit LUT8 or DLY/CNT5(8bits) Select	0: 3-bit LUT8 1: DLY/CNT5(8bits)	Valid	Valid
	1196	3-bit LUT7 or DLY/CNT4(8bits) Select	0: 3-bit LUT7 1: DLY/CNT4(8bits)	Valid	Valid
	1197	3-bit LUT6 or DLY/CNT3(8bits) Select	0: 3-bit LUT6 1: DLY/CNT3(8bits)	Valid	Valid
	1198	3-bit LUT5 or DLY/CNT2(8bits) Select	0: 3-bit LUT5 1: DLY/CNT2(8bits)	Valid	Valid
	1199	3-bit LUT4 or DFF7 with nRST/nSET Select	0: 3-bit LUT4 1: DFF7 with nRST/nSET	Valid	Valid
2-bit LUT1/DFF1					
96	1200	2-bit LUT1 [0]		Valid	Valid
	1201	2-bit LUT1 [1]/DFF1 Initial Polarity Select	0: Low 1: High	Valid	Valid
	1202	2-bit LUT1 [2]/DFF1 Output Select	0: Q output 1: nQ output	Valid	Valid
	1203	2-bit LUT1 [3]/DFF1 or LATCH Select	0: DFF function 1: LATCH function	Valid	Valid
2-bit LUT0/DFF0					
96	1204	2-bit LUT0 [0]		Valid	Valid
	1205	2-bit LUT0 [1]/DFF0 Initial Polarity Select	0: Low 1: High	Valid	Valid
	1206	2-bit LUT0 [2]/DFF0 Output Select	0: Q output 1: nQ output	Valid	Valid
	1207	2-bit LUT0 [3]/DFF0 or LATCH Select	0: DFF function 1: LATCH function	Valid	Valid
2-bit LUT3/PGen					
97	1211:1208	2-bit LUT3 [3:0] or PGen 4bit counter data [3:0]		Valid	Valid

Address		Signal Function	Register Bit Definition	I ² C Interface	
Byte	Register Bit			Read	Write
2-bit LUT2/DFF2					
97	1212	2-bit LUT2 [0]		Valid	Valid
	1213	2-bit LUT2 [1]/DFF2 Initial Polarity Select	0: Low 1: High	Valid	Valid
	1214	2-bit LUT2 [2]/DFF2 Output Select	0: Q output 1: nQ output	Valid	Valid
	1215	2-bit LUT2 [3]/DFF2 or LATCH Select	0: DFF function 1: LATCH function	Valid	Valid
3-bit LUT0/DFF3					
98	1219:1216	3-bit LUT0 [3:0]		Valid	Valid
	1220	3-bit LUT0 [4]/DFF3 Initial Polarity Select	0: Low 1: High	Valid	Valid
	1221	3-bit LUT0 [5]/DFF3 nRST or nSET Select	0: nRST from Matrix Output 1: nSET from Matrix Output	Valid	Valid
	1222	3-bit LUT0 [6]/DFF3 Output Select	0: Q output 1: nQ output	Valid	Valid
	1223	3-bit LUT0 [7]/DFF3 or LATCH Select	0: DFF function 1: LATCH function	Valid	Valid
3-bit LUT1/DFF4					
99	1227:1224	3-bit LUT1 [3:0]		Valid	Valid
	1228	3-bit LUT1 [4]/DFF4 Initial Polarity Select	0: Low 1: High	Valid	Valid
	1229	3-bit LUT1 [5]/DFF4 nRST or nSET Select	0: nRST from Matrix Output 1: nSET from Matrix Output	Valid	Valid
	1230	3-bit LUT1 [6]/DFF4 Output Select	0: Q output 1: nQ output	Valid	Valid
	1231	3-bit LUT1 [7]/DFF4 or LATCH Select	0: DFF function 1: LATCH function	Valid	Valid
3-bit LUT2/DFF5					
9A	1235:1232	3-bit LUT2 [3:0]		Valid	Valid
	1236	3-bit LUT2 [4]/DFF5 Initial Polarity Select	0: Low 1: High	Valid	Valid
	1237	3-bit LUT2 [5]/DFF5 nRST or nSET Select	0: nRST from Matrix Output 1: nSET from Matrix Output	Valid	Valid
	1238	3-bit LUT2 [6]/DFF5 Output Select	0: Q output 1: nQ output	Valid	Valid
	1239	3-bit LUT2 [7]/DFF5 or LATCH Select	0: DFF function 1: LATCH function	Valid	Valid

Address		Signal Function	Register Bit Definition	I ² C Interface	
Byte	Register Bit			Read	Write
3-bit LUT3/DFF6					
9B	1243:1240	3-bit LUT3 [3:0]		Valid	Valid
	1244	3-bit LUT3 [4]/DFF6 Initial Polarity Select	0: Low 1: High	Valid	Valid
	1245	3-bit LUT3 [5]/DFF6 nRST or nSET Select	0: nRST from Matrix Output 1: nSET from Matrix Output	Valid	Valid
	1246	3-bit LUT3 [6]/DFF6 Output Select	0: Q output 1: nQ output	Valid	Valid
	1247	3-bit LUT3 [7]/DFF6 or LATCH Select	0: DFF function 1: LATCH function	Valid	Valid
3-bit LUT4/DFF7					
9C	1251:1248	3-bit LUT4 [3:0]		Valid	Valid
	1252	3-bit LUT4 [4]/DFF7 Initial Polarity Select	0: Low 1: High	Valid	Valid
	1253	3-bit LUT4 [5]/DFF7 nRST or nSET Select	0: nRST from Matrix Output 1: nSET from Matrix Output	Valid	Valid
	1254	3-bit LUT4 [6]/DFF7 Output Select	0: Q output 1: nQ output	Valid	Valid
	1255	3-bit LUT4 [7]/DFF7 or LATCH Select	0: DFF function 1: LATCH function	Valid	Valid
3-bit LUT10/Pipe Delay					
9D	1259:1256	3-bit LUT10 [3:0]/Pipe Delay OUT0 Select		Valid	Valid
	1263:1260	3-bit LUT10 [7:4]/Pipe Delay OUT1 Select		Valid	Valid
9E	1265:1264	Select the Edge Mode of Programmable Delay and Edge Detector	00: Rising Edge Detector 01: Falling Edge Detector 10: Both Edge Detector 11: Both Edge Delay	Valid	Valid
	1267:1266	Delay Value Select for Programmable Delay and Edge Detector ($V_{DD} = 3.3V$, typical)	00: 125 ns 01: 250 ns 10: 375 ns 11: 500 ns	Valid	Valid
	1269:1268	Reserved		Valid	Valid
	1270	3-bit LUT10 or Pipe Delay Select	0: 3-bit LUT10 1: Pipe Delay	Valid	Valid
	1271	Pipe Delay OUT1 Polarity Select	0: Non-inverted 1: Inverted	Valid	Valid

Address		Signal Function	Register Bit Definition	I ² C Interface	
Byte	Register Bit			Read	Write
DLY/CNT2					
9F	1273:1272	DLY2 Mode Select or Asynchronous CNT2 Reset	00: On both Falling and Rising Edges (for Delay and Counter Reset) 01: on Falling Edge only (for Delay and Counter Reset) 10: on Rising Edge only (for Delay and Counter Reset) 11: No Delay on either Falling or Rising Edges/High Level Reset	Valid	Valid
	1276:1274	DLY/CNT2 Clock Source Select	000: Internal OSC clock 001: OSC/4 010: OSC/12 011: OSC/24 100: OSC/64 101: 25 MHz OSC clock 110: External Clock 111: Counter1 Overflow	Valid	Valid
	1277	DLY/CNT2 Output Selection if DLY/CNT2 Mode Selection is "11"	0: Default Output 1: Edge Detector Output	Valid	Valid
	1279:1278	DLY/CNT2 Mode Selection	00: Delay mode 01: One Shot 10: Freq. Detect 11: Counter mode	Valid	Valid
DLY/CNT3					
A0	1281:1280	DLY3 Mode Select or Asynchronous CNT3 Reset	00: On both Falling and Rising Edges (for Delay and Counter Reset) 01: on Falling Edge only (for Delay and Counter Reset) 10: on Rising Edge only (for Delay and Counter Reset) 11: No Delay on either Falling or Rising Edges/High Level Reset	Valid	Valid
	1284:1282	DLY/CNT3 Clock Source Select	000: Internal OSC clock 001: OSC/4 010: OSC/12 011: OSC/24 100: OSC/64 101: 25 MHz OSC clock 110: External Clock 111: Counter2 Overflow	Valid	Valid
	1285	DLY/CNT3 Output Selection if DLY/CNT3 Mode Selection is "11"	0: Default Output 1: Edge Detector Output	Valid	Valid
	1287:1286	DLY/CNT3 Mode Selection	00: Delay mode 01: One Shot 10: Freq. Detect 11: Counter mode	Valid	Valid

Address		Signal Function	Register Bit Definition	I ² C Interface	
Byte	Register Bit			Read	Write
DLY/CNT4					
A1	1289:1288	DLY4 Mode Select or Asynchronous CNT4 Reset	00: On both Falling and Rising Edges (for Delay and Counter Reset) 01: on Falling Edge only (for Delay and Counter Reset) 10: on Rising Edge only (for Delay and Counter Reset) 11: No Delay on either Falling or Rising Edges/High Level Reset	Valid	Valid
	1292:1290	DLY/CNT4 Clock Source Select	000: Internal OSC clock 001: OSC/4 010: OSC/12 011: OSC/24 100: OSC/64 101: 25 MHz OSC clock 110: External Clock 111: Counter3 Overflow	Valid	Valid
	1293	DLY/CNT4 Output Selection if DLY/CNT4 Mode Selection is "11"	0: Default Output 1: Edge Detector Output	Valid	Valid
	1295:1294	DLY/CNT4 Mode Selection	00: Delay mode 01: One Shot 10: Freq. Detect 11: Counter mode	Valid	Valid
DLY/CNT5					
A2	1297:1296	DLY5 Mode Select or Asynchronous CNT5 Reset	00: On both Falling and Rising Edges (for Delay and Counter Reset) 01: on Falling Edge only (for Delay and Counter Reset) 10: on Rising Edge only (for Delay and Counter Reset) 11: No Delay on either Falling or Rising Edges/High Level Reset	Valid	Valid
	1300:1298	DLY/CNT5 Clock Source Select	000: Internal OSC clock 001: OSC/4 010: OSC/12 011: OSC/24 100: OSC/64 101: 25 MHz OSC clock 110: External Clock 111: Counter4 Overflow	Valid	Valid
	1301	DLY/CNT5 Output Selection if DLY/CNT5 Mode Selection is "11"	0: Default Output 1: Edge Detector Output	Valid	Valid
	1303:1302	DLY/CNT5 Mode Selection	00: Delay mode 01: One Shot 10: Freq. Detect 11: Counter mode	Valid	Valid

Address		Signal Function	Register Bit Definition	I ² C Interface	
Byte	Register Bit			Read	Write
DLY/CNT6					
A3	1305:1304	DLY6 Mode Select or Asynchronous CNT6 Reset	00: On both Falling and Rising Edges (for Delay and Counter Reset) 01: on Falling Edge only (for Delay and Counter Reset) 10: on Rising Edge only (for Delay and Counter Reset) 11: No Delay on either Falling or Rising Edges/High Level Reset	Valid	Valid
	1308:1306	DLY/CNT6 Clock Source Select	000: Internal OSC clock 001: OSC/4 010: OSC/12, 011: OSC/24 100: OSC/64 101: 25 MHz OSC clock 110: External Clock 111: Counter5 Overflow	Valid	Valid
	1309	DLY/CNT6 Output Selection if DLY/CNT6 Mode Selection is "11"	0: Default Output 1: Edge Detector Output	Valid	Valid
	1311:1310	DLY/CNT6 Mode Selection	00: Delay mode 01: One Shot 10: Freq. Detect 11: Counter mode	Valid	Valid
DLY/CNT0					
A4	1313:1312	DLY0 Mode Select or Asynchronous CNT0 Reset (16bits)	00: On both Falling and Rising Edges (for Delay and Counter Reset) 01: on Falling Edge only (for Delay and Counter Reset) 10: on Rising Edge only (for Delay and Counter Reset) 11: No Delay on either Falling or Rising Edges/High Level Reset	Valid	Valid
	1316:1314	DLY/CNT0 Clock Source Select (16bits)	000: Internal OSC clock 001: OSC/4 010: OSC/12 011: OSC/24 100: OSC/64 101: 25 MHz OSC clock 110: External Clock 111: Counter6 Overflow	Valid	Valid
	1317	CNT0/FSM0's Q are Set to data or Reset to 0s Selection (16bits)	0: Reset to 0s 1: Set to data (Registers [1583:1576, 1591:1584])	Valid	Valid
	1319:1318	DLY/CNT0 Mode Selection (16bits)	00: Delay mode 01: One Shot 10: Freq. Detect 11: Counter mode	Valid	Valid

Address		Signal Function	Register Bit Definition	I ² C Interface	
Byte	Register Bit			Read	Write
DLY/CNT1					
A5	1321:1320	DLY1 Mode Select or Asynchronous CNT1 Reset (16bits)	00: On both Falling and Rising Edges (for Delay and Counter Reset) 01: on Falling Edge only (for Delay and Counter Reset) 10: on Rising Edge only (for Delay and Counter Reset) 11: No Delay on either Falling or Rising Edges/High Level Reset	Valid	Valid
	1324:1322	DLY/CNT1 Clock Source Select (16bits)	000: Internal OSC clock 001: OSC/4 010: OSC/12 011: OSC/24 100: OSC/64 101: 25 MHz OSC clock 110: External Clock 111: Counter0 Overflow	Valid	Valid
	1325	CNT1/FSM1's Q are Set to data or Reset to 0s Selection (16bits)	0: Reset to 0s 1: Set to data (Registers [1599:1592, 1607:1600])	Valid	Valid
	1327:1326	DLY/CNT1 Mode Selection (16bits)	00: Delay mode 01: One Shot 10: Freq. Detect 11: Counter mode	Valid	Valid
DLY/CNTx One-Shot/Freq. Detect Output Polarity					
A6	1328	DLY/CNT0 stop and restarting enable in CNT mode when new data is loaded	0: Disable 1: Enable	Valid	Valid
	1329	Select the Polarity of DLY/CNT6's One Shot/Freq. Detect Output	0: Default Output 1: Inverted Output	Valid	Valid
	1330	Select the Polarity of DLY/CNT5's One Shot/Freq. Detect Output	0: Default Output 1: Inverted Output	Valid	Valid
	1331	Select the Polarity of DLY/CNT4's One Shot/Freq. Detect Output	0: Default Output 1: Inverted Output	Valid	Valid
	1332	Select the Polarity of DLY/CNT3's One Shot/Freq. Detect Output	0: Default Output 1: Inverted Output	Valid	Valid
	1333	Select the Polarity of DLY/CNT2's One Shot/Freq. Detect Output	0: Default Output 1: Inverted Output	Valid	Valid
	1334	Select the Polarity of DLY/CNT1's One Shot/Freq. Detect Output	0: Default Output 1: Inverted Output	Valid	Valid
	1335	Select the Polarity of DLY/CNT0's One Shot/Freq. Detect Output	0: Default Output 1: Inverted Output	Valid	Valid

Address		Signal Function	Register Bit Definition	I ² C Interface	
Byte	Register Bit			Read	Write
Oscillators					
A7	1337:1336	OSC Clock Pre-divider for 25 MHz	00: Div1 01: Div2 10: Div4 11: Div8	Valid	Valid
	1338	OSC Fast Start-Up Enable for 25 kHz/2 MHz	0: Disable 1: Enable	Valid	Valid
	1340:1339	OSC Clock Pre-divider for 25 kHz/2 MHz	00: Div1 01: Div2 10: Div4 11: Div8	Valid	Valid
	1341	Force 25 MHz Oscillator ON	0: Auto Power-On (If any CNT/DLY use 25 MHz source) 1: Force Power-On	Valid	Valid
	1342	Oscillator (25 kHz: OSC, 2 MHz: OSC) Select	0: 25 kHz OSC 1: 2 MHz OSC	Valid	Valid
	1343	Force 25 kHz/2 MHz Oscillator ON	0: Auto Power-On (if any CNT/DLY use 25k/2 MHz source) 1: Force Power-On	Valid	Valid
A8	1346:1344	Internal OSC 25 kHz/2 MHz Frequency Divider Control for matrix input [28]	000: OSC/1 001: OSC/2 010: OSC/3 011: OSC/4 100: OSC/8 101: OSC/12 110: OSC/24 111: OSC/64	Valid	Valid
	1349:1347	Internal OSC 25 kHz/2 MHz Frequency Divider Control for matrix input [27]	000: OSC/1 001: OSC/2 010: OSC/3 011: OSC/4 100: OSC/8 101: OSC/12 110: OSC/24 111: OSC/64	Valid	Valid
	1350	OSC Clock 25 kHz/2 MHz to matrix input [28] enable	0: Disable 1: Enable	Valid	Valid
	1351	OSC Clock 25 kHz/2 MHz to matrix input [27] enable	0: Disable 1: Enable	Valid	Valid

Address		Signal Function	Register Bit Definition	I ² C Interface	
Byte	Register Bit			Read	Write
A9	1354:1352	SM_reg_init [2:0] for SM state default setup bits		Valid	Valid
	1355	Reserved		Valid	Valid
	1356	OSC Clock 25 MHz to matrix input [29] enable	0: Disable 1: Enable	Valid	Valid
	1357	External Clock Source Select instead of 25 MHz	0: Internal Oscillator 1: External Clock from Pin 13	Valid	Valid
	1358	External Clock Source Select instead of 25 kHz/2 MHz	0: Internal Oscillator 1: External Clock from Pin 14	Valid	Valid
	1359	DLY/CNT1 stop and restarting enable in CNT mode when new data is loaded	0: Disable 1: Enable	Valid	Valid
AA	1367:1362	Reserved		Valid	Valid
AB	1375:1368	Reserved		Valid	Valid
AC	1383:1376	Reserved		Valid	Valid
AD	1391:1384	Reserved		Valid	Valid
AE	1399:1392	Reserved		Valid	Valid
AF	1407:1400	Reserved		Valid	Valid
B0	1415:1408	Reserved		Valid	Valid
B1	1423:1416	Reserved		Valid	Valid
B2	1431:1424	Reserved		Valid	Valid
B3	1439:1432	Reserved		Valid	Valid
B4	1447:1440	Reserved		Valid	Valid
B5	1455:1448	Reserved		Valid	Valid
Filter/Edge Detector					
B6	1457:1456	Select the edge mode of Edge Detector_1	00: Rising Edge 01: Falling Edge 10: Both Edge 11: Delay	Valid	Valid
	1458	Filter_1/Edge Detector_1 output Polarity Select	0: Filter_1 output 1: Filter_1 output inverted	Valid	Valid
	1459	Filter_1 or Edge Detector_1 Select (Typ 30 ns at V _{DD} = 3.3 V)	0: Filter_1 1: Edge Detector_1	Valid	Valid
	1461:1460	Select the edge mode of Edge Detector_0	00: Rising Edge 01: Falling Edge 10: Both Edge 11: Delay	Valid	Valid
	1462	Filter_0/Edge Detector_0 output Polarity Select	0: Filter_0 output 1: Filter_0 output inverted	Valid	Valid
	1463	Filter_0 or Edge Detector_0 Select (Typ 47 ns at V _{DD} = 3.3 V)	0: Filter_0 1: Edge Detector_0	Valid	Valid

Address		Signal Function	Register Bit Definition	I ² C Interface	
Byte	Register Bit			Read	Write
V_{REF}/Bandgap					
B7	1464	Reserved		Valid	Valid
	1466:1465	Bandgap OK for ACMP Output Delay Time Select, the start Time is "nReset_core go to High"	00 or 10 with reg [1474:1472] = 100 (Wide V _{DD} range, 1.7 V~ 5.5 V): Auto-delay mode, 550 μs for V _{DD} < 2.7 V and 100 μs for 2.7 V < V _{DD} 00 or 10 with reg [1474:1472] = X10: Always 100 μs delay for 2.7 V < V _{DD} 00 or 10 with reg [1474:1472] = XX1: Always 550 μs delay for V _{DD} < 2.7 V, 01: Always 550 μs delay regardless of reg [1474:1472] and V _{DD} , 11: Always 100 μs delay with 2.7 V < V _{DD} regardless of reg [1474:1472]	Valid	Valid
	1467	Reserved		Valid	Valid
	1468	Reserved		Valid	Valid
	1469	Reserved		Valid	Valid
	1470	Reserved		Valid	Valid
	1471	Two consecutive DFFs enable for SM	0: Disable 1: Enable	Valid	Valid
B8	1474:1472	Power divider (V _{DD} /3, V _{DD} /4) ON/OFF	0XX: Power divider off (if there is no use of V _{DD} /3, V _{DD} /4 at ACMP negative in) 100: Reserved X10: Reserved XX1: Reserved	Valid	Valid
	1475	V _{DD} Bypass Enable when device power is 1.8 V	0: Regulator Auto ON 1: Regulator OFF (V _{DD} Bypass)	Valid	Valid
	1476	Force Bandgap ON	0: Auto-Mode 1: Enable (if chip is Power-down, the Bandgap will Power-down even if it is Set to 1)	Valid	Valid
	1477	NVM Power-down	0: None (Or Programming Enable) 1: Power-down (Or Programming Disable)	Valid	Valid
	1478	Reserved		Valid	Valid
	1479	GPIO Quick Charge Enable	0: Disable 1: Enable	Valid	Valid
B9	1487:1480	Reserved		Valid	Valid

Address		Signal Function	Register Bit Definition	I ² C Interface	
Byte	Register Bit			Read	Write
BA	1488	Reserved		Valid	Valid
	1489	Reserved	1: Normal wake time (Default)	Valid	Valid
	1490	ACMP0 Wake and Sleep function Enable	0: Disable 1: Enable	Valid	Valid
	1491	ACMP1 Wake and Sleep function Enable	0: Disable 1: Enable	Valid	Valid
	1492	ACMP2 Wake and Sleep function Enable	0: Disable 1: Enable	Valid	Valid
	1493	Reserved		Valid	Valid
	1494	Wake Sleep Output State When WS Oscillator is Power-down if DLY/CNT0 Mode Selection is "11"	0: Low 1: High	Valid	Valid
	1495	Wake Sleep Ratio Control Mode Selection if DLY/CNT0 Mode Selection is "11"	0: Default Mode 1: Wake Sleep Ratio Control Mode	Valid	Valid
BB	1503:1496	Reserved		Invalid	Invalid
BC	1511:1504	Reserved		Invalid	Invalid
BD	1519:1512	Reserved		Invalid	Invalid
BE	1527:1520	Reserved		Invalid	Invalid
BF	1535:1528	Reserved		Invalid	Invalid
LUT/DLY/CNT Control Data					
C0	1543:1536	3-bit LUT5 [7:0] or DLY/CNT2 Control Data	1 - 255 (Delay Time = [Counter Control Data + 1]/Freq)	Valid	Valid
C1	1551:1544	3-bit LUT6 [7:0] or DLY/CNT3 Control Data	1 - 255 (Delay Time = [Counter Control Data + 1]/Freq)	Valid	Valid
C2	1559:1552	3-bit LUT7 [7:0] or DLY/CNT4 Control Data	1 - 255 (Delay Time = [Counter Control Data + 1]/Freq)	Valid	Valid
C3	1567:1560	3-bit LUT8 [7:0] or DLY/CNT5 Control Data	1 - 255 (Delay Time = [Counter Control Data + 1]/Freq)	Valid	Valid
C4	1575:1568	3-bit LUT9 [7:0] or DLY/CNT6 Control Data	1 - 255 (Delay Time = [Counter Control Data + 1]/Freq)	Valid	Valid
C5	1583:1576	4-bit LUT0 [15:0] or DLY/CNT0 (16bits, [15:0] = [1591:1576]) Control Data	1 - 65535 (Delay Time = [Counter Control Data + 2]/Freq)	Valid	Valid
C6	1591:1584			Valid	Valid
C7	1599:1592	4-bit LUT1 [15:0] or DLY/CNT1 (16bits, [15:0] = [1607:1592]) Control Data	1 - 65535 (Delay Time = [Counter Control Data + 2]/Freq)	Valid	Valid
C8	1607:1600			Valid	Valid
C9	1615:1608	PGen pattern data [15:0] = [1623:1608]		Valid	Valid
CA	1623:1616			Valid	Valid

Address		Signal Function	Register Bit Definition	I ² C Interface	
Byte	Register Bit			Read	Write
ACMP0					
CB	1628:1624	ACMP0-IN Voltage Select	00000: 50 mV 00001: 100 mV 00010: 150 mV 00011: 200 mV 00100: 250 mV 00101: 300 mV 00110: 350 mV 00111: 400 mV 01000: 450 mV 01001: 500 mV 01010: 550 mV 01011: 600 mV 01100: 650 mV 01101: 700 mV 01110: 750 mV 01111: 800 mV 10000: 850 mV 10001: 900 mV 10010: 950 mV 10011: 1 V 10100: 1.05 V 10101: 1.1 V 10110: 1.15 V 10111: 1.2 V 11000: V _{DD} /3 11001: V _{DD} /4 11010: Reserved 11011: Pin 5: EXT_V _{REF} 11100: Reserved 11101: Pin 5: EXT_V _{REF} /2 11110: Reserved 11111: Reserved	Valid	Valid
	1630:1629	ACMP0 Positive Input Divider	00: 1.0x 01: 0.5x 10: 0.33x 11: 0.25x	Valid	Valid
	1631	ACMP0 Low Bandwidth (MAX: 1 MHz) Enable	0: OFF 1: ON	Valid	Valid
ACMP1					
CC	1636:1632	ACMP1-IN Voltage Select	00000: 50 mV 00001: 100 mV 00010: 150 mV 00011: 200 mV 00100: 250 mV 00101: 300 mV 00110: 350 mV 00111: 400 mV 01000: 450 mV 01001: 500 mV 01010: 550 mV 01011: 600 mV 01100: 650 mV 01101: 700 mV 01110: 750 mV 01111: 800 mV 10000: 850 mV 10001: 900 mV 10010: 950 mV 10011: 1 V 10100: 1.05 V 10101: 1.1 V 10110: 1.15 V 10111: 1.2 V 11000: V _{DD} /3 11001: V _{DD} /4 11010: Reserved 11011: Reserved 11100: Reserved 11101: Reserved 11110: Reserved 11111: Reserved	Valid	Valid

Address		Signal Function	Register Bit Definition	I ² C Interface	
Byte	Register Bit			Read	Write
CC	1638:1637	ACMP1 Positive Input Divider	00: 1.0x 01: 0.5x 10: 0.33x 11: 0.25x	Valid	Valid
	1639	ACMP1 Low Bandwidth (MAX: 1 MHz) Enable	0: OFF 1: ON	Valid	Valid
ACMP2					
CD	1644:1640	ACMP2-IN Voltage Select	00000: 50 mV 00001: 100 mV 00010: 150 mV 00011: 200 mV 00100: 250 mV 00101: 300 mV 00110: 350 mV 00111: 400 mV 01000: 450 mV 01001: 500 mV 01010: 550 mV 01011: 600 mV 01100: 650 mV 01101: 700 mV 01110: 750 mV 01111: 800 mV 10000: 850 mV 10001: 900 mV 10010: 950 mV 10011: 1 V 10100: 1.05 V 10101: 1.1 V 10110: 1.15 V 10111: 1.2 V 11000: V _{DD} /3 11001: V _{DD} /4 11010: Reserved 11011: Reserved 11100: Reserved 11101: Reserved 11110: Reserved 11111: Reserved	Valid	Valid
	1646:1645	ACMP2 Positive Input Divider	00: 1.0x 01: 0.5x 10: 0.33x 11: 0.25x	Valid	Valid
	1647	ACMP2 Low Bandwidth (MAX: 1 MHz) Enable	0: OFF 1: ON	Valid	Valid
CE	1655:1648	Reserved		Valid	Valid
Miscellaneous					
CF	1656	Enable Normal GPIO for P0-P3	0: IO Expander 1: Normal GPIO	Valid	Valid
	1657	Switch from "Matrix OUT: OSC 25 MHz PD" to "Matrix OUT: OSC 25 MHz Force On"	0: OSC PD 1: OSC Force On (Matrix Output [59])	Valid	Valid
	1658	Switch from "Matrix OUT: OSC 25 kHz/2 MHz PD" to "Matrix OUT: OSC 25 kHz/2 MHz Force On"	0: OSC PD 1: OSC Force On (Matrix Output [58])	Valid	Valid

Address		Signal Function	Register Bit Definition	I ² C Interface	
Byte	Register Bit			Read	Write
CF	1659	Reserved		Valid	Valid
	1660	Reserved		Valid	Valid
	1661	Reserved		Valid	Valid
	1662	I ² C reset bit with reloading NVM into Data register	0: Keep existing condition 1: Reset execution	Valid	Valid
	1663	Reserved		Valid	Valid
D0	1671:1664	Reserved		Valid	Valid
D1	1679:1672	Reserved		Valid	Valid
D2	1687:1680	Reserved		Valid	Valid
D3	1695:1688	Reserved		Valid	Valid
D4	1703:1696	Reserved		Valid	Valid
D5	1711:1704	Reserved		Valid	Valid
D6	1719:1712	Reserved		Valid	Valid
D7	1727:1720	Reserved		Valid	Valid
D8	1735:1728	I ² C Control Code[6:0]		Valid	invalid
D9	1743:1736	Reserved		Invalid	Invalid
DA	1751:1744	Reserved		Invalid	Invalid
DB	1759:1752	User configurable RAM/OTP Byte 3		Valid	Valid
DC	1767:1760	User configurable RAM/OTP Byte 4		Valid	Valid
DD	1775:1768	User configurable RAM/OTP Byte 5		Invalid	Invalid
DE	1783:1776	User configurable RAM/OTP Byte 6		Invalid	Invalid
DF	1791:1784	User configurable RAM/OTP Byte 7		Invalid	Invalid
E0	1799:1792	Reserved		Invalid	Invalid
E1	1807:1800	Reserved		Invalid	Invalid
E2	1815:1808	Reserved		Invalid	Invalid
E3	1823:1816	Reserved		Invalid	Invalid
E4	1831:1824	Reserved		Valid	Valid
E5	1832	I ² C lock for read bits [1535:32] (Bank 0/1/2)	0: Disable (Programmed data can be read) 1: Enable (Programmed data can't be read)	Valid	Invalid
	1833	Reserved		Valid	Invalid
	1835:1834	Reserved		Valid	Invalid
	1839:1836	Reserved		Valid	Invalid
E6	1847:1840	16-bit Pattern ID Byte 0 (From NVM): ID[23:16]		Valid	Valid
E7	1855:1848	Reserved		Valid	Invalid
E8	1863:1856	Reserved		Valid	Invalid

Address		Signal Function	Register Bit Definition	I ² C Interface	
Byte	Register Bit			Read	Write
E9	1867:1864	Reserved		Valid	Invalid
	1868	Reserved		Valid	Invalid
	1869	Reserved		Valid	Invalid
	1870	BANK0/1/2/3 I ² C-write protection bit	0: Writable 1: Non-writable	Valid	Invalid
	1871	I ² C lock for write bits [1535:32] (Bank 0/1/2)	0: Writable 1: Non-writable	Valid	Invalid
EA	1879:1872	CNT4 Counted Value		Valid	Invalid
EB	1887:1880	CNT0 (16bits) = [1895:1880] Counted Value		Valid	Invalid
EC	1895:1888			Valid	Invalid
ED	1903:1896	CNT6 Counted Value		Valid	Invalid
EE	1911:1904	CNT1 (16bits) = [1919:1904] Counted Value		Valid	Invalid
EF	1919:1912			Valid	Invalid
Matrix Input					
F0	1920	Matrix Input 0	Ground	Valid	Invalid
	1921	Matrix Input 1	Pin 2 Digital Input	Valid	Invalid
	1922	Reserved		Valid	Invalid
	1923	Matrix Input 3	Pin 3 Digital Input	Valid	Invalid
	1924	Reserved		Valid	Invalid
	1925	Matrix Input 5	Pin 4 Digital Input	Valid	Invalid
	1926	Matrix Input 6	Pin 5 Digital Input	Valid	Invalid
	1927	Matrix Input 7	Pin 14 Digital Input	Valid	Invalid
F1	1928	Matrix Input 8	2-bit LUT0/DFF0 Output	Valid	Invalid
	1929	Matrix Input 9	2-bit LUT1/DFF1 Output	Valid	Invalid
	1930	Matrix Input 10	2-bit LUT2/DFF2 Output	Valid	Invalid
	1931	Matrix Input 11	2-bit LUT3/PGen Output	Valid	Invalid
	1932	Matrix Input 12	3-bit LUT0/DFF3 Output	Valid	Invalid
	1933	Matrix Input 13	3-bit LUT1/DFF4 Output	Valid	Invalid
	1934	Matrix Input 14	3-bit LUT2/DFF5 Output	Valid	Invalid
	1935	Matrix Input 15	3-bit LUT3/DFF6 Output	Valid	Invalid

Address		Signal Function	Register Bit Definition	I ² C Interface	
Byte	Register Bit			Read	Write
F2	1936	Matrix Input 16	3-bit LUT4/DFF7 Output	Valid	Invalid
	1937	Matrix Input 17	3-bit LUT5/CNT_DLY2(8bit) Output	Valid	Invalid
	1938	Matrix Input 18	3-bit LUT6/CNT_DLY3(8bit) Output	Valid	Invalid
	1939	Matrix Input 19	3-bit LUT7/CNT_DLY4(8bit) Output	Valid	Invalid
	1940	Matrix Input 20	3-bit LUT8/CNT_DLY5(8bit) Output	Valid	Invalid
	1941	Matrix Input 21	3-bit LUT9/CNT_DLY6(8bit) Output	Valid	Invalid
	1942	Matrix Input 22	4-bit LUT0/CNT_DLY0(16bit) Output	Valid	Invalid
	1943	Matrix Input 23	4-bit LUT1/CNT_DLY1(16bit) Output	Valid	Invalid
F3	1944	Matrix Input 24	3-bit LUT10/Pipe Delay (1st stage) Output	Valid	Invalid
	1945	Matrix Input 25	Pipe Delay Output0	Valid	Invalid
	1946	Matrix Input 26	Pipe Delay Output1	Valid	Invalid
	1947	Matrix Input 27	Fixed "L" output because it is OSC clock	Valid	Invalid
	1948	Matrix Input 28	Fixed "L" output because it is OSC clock	Valid	Invalid
	1949	Matrix Input 29	Fixed "L" output because it is OSC clock	Valid	Invalid
	1950	Matrix Input 30	Filter0/Edge Detect0 Output	Valid	Invalid
	1951	Matrix Input 31	Filter1/Edge Detect1 Output	Valid	Invalid
F4	1952	Matrix Input 32	Fixed "L" output because no registers	Valid	Valid
	1953	Matrix Input 33	Fixed "L" output because no registers	Valid	Valid
	1954	Matrix Input 34	Fixed "L" output because no registers	Valid	Valid
	1955	Matrix Input 35	Fixed "L" output because no registers	Valid	Valid
	1956	Matrix Input 36	Fixed "L" output because no registers	Valid	Valid
	1957	Matrix Input 37	Fixed "L" output because no registers	Valid	Valid
	1958	Matrix Input 38	Fixed "L" output because no registers	Valid	Valid
	1959	Matrix Input 39	Fixed "L" output because no registers	Valid	Valid
F5	1960	Matrix Input 40	Reserved	Valid	Invalid
	1961	Matrix Input 41	Reserved	Valid	Invalid
	1962	Matrix Input 42	Reserved	Valid	Invalid
	1963	Matrix Input 43	Reserved	Valid	Invalid
	1964	Matrix Input 44	Reserved	Valid	Invalid
	1965	Matrix Input 45	Reserved	Valid	Invalid
	1966	Matrix Input 46	Reserved	Valid	Invalid
	1967	Matrix Input 47	Reserved	Valid	Invalid

Address		Signal Function	Register Bit Definition	I ² C Interface	
Byte	Register Bit			Read	Write
F6	1968	Matrix Input 48	Fixed "L" output because no registers	Valid	Invalid
	1969	Reserved		Valid	Invalid
	1970	Matrix Input 50	Fixed "L" output because no registers	Valid	Invalid
	1971	Reserved		Valid	Invalid
	1972	Matrix Input 52	Fixed "L" output because no registers	Valid	Invalid
	1973	Matrix Input 53	Fixed "L" output because no registers	Valid	Invalid
	1974	Reserved	Fixed "L" output because no registers	Valid	Invalid
	1975	Reserved	Fixed "L" output because no registers	Valid	Invalid
F7	1976	Matrix Input 56	Pin 13 Digital Input	Valid	Invalid
	1977	Matrix Input 57	ACMP_0 Output	Valid	Invalid
	1978	Matrix Input 58	ACMP_1 Output	Valid	Invalid
	1979	Matrix Input 59	ACMP_2 Output	Valid	Invalid
	1980	Reserved		Valid	Invalid
	1981	Matrix Input 61	Programmable Delay with Edge Detector Output	Valid	Invalid
	1982	Matrix Input 62	nRST_core	Valid	Invalid
	1983	Matrix Input 63	V _{DD}	Valid	Invalid
Reserved					
F8	1991:1984	Reserved		Valid	Invalid
F9	1999:1992	Reserved		Valid	Invalid
FA	2007:2000	Reserved		Valid	Invalid
FB	2015:2008	Reserved		Valid	Valid
FC	2023:2016	Reserved		Valid	Invalid
FD	2031:2024	Reserved		Valid	Invalid
FE	2039:2032	Reserved		Valid	Valid
FF	2047:2040	Reserved		Valid	Valid

15. Package Information

15.1 Package Outline Drawings

15.1.1 Package Outline for STQFN 14L 2.0 mm x 2.2 mm 0.4P COL Package

JEDEC MO-220, Variation WECE

IC Net Weight: 0.0068 g

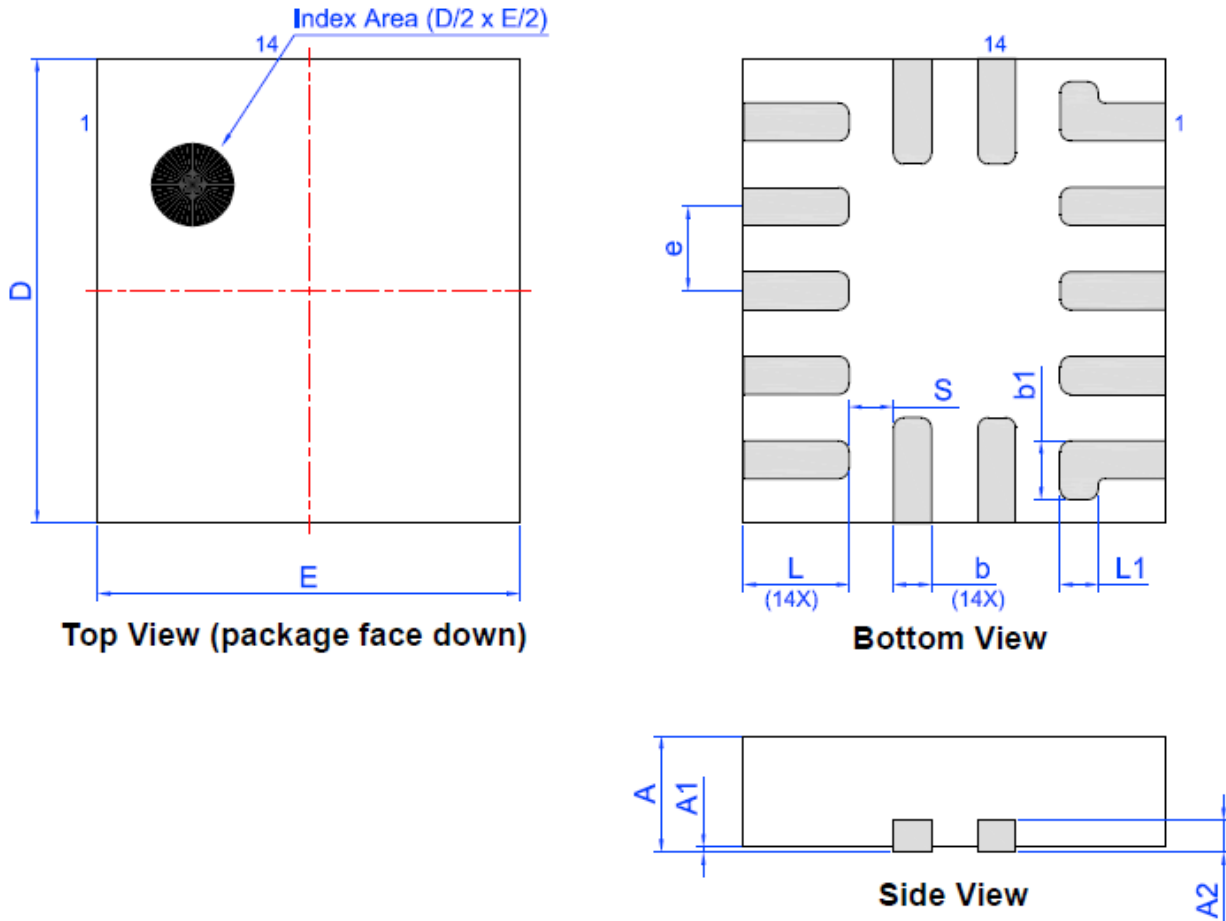

Unit: mm

Symbol	Min	Nom.	Max	Symbol	Min	Nom.	Max
A	0.50	0.55	0.60	D	2.15	2.20	2.25
A1	0.005	-	0.050	E	1.95	2.00	2.05
A2	0.10	0.15	0.20	L	0.45	0.50	0.55
b	0.13	0.18	0.23	S	0.21 TYP		
e	0.40 BSC			b1	0.28 TYP		
				L1	0.18 TYP		

Figure 100. STQFN-14 Package Outline Drawing

15.2 Package Top Marking

15.2.1 STQFN 14L 2.0 mm x 2.2 mm 0.4P COL Package

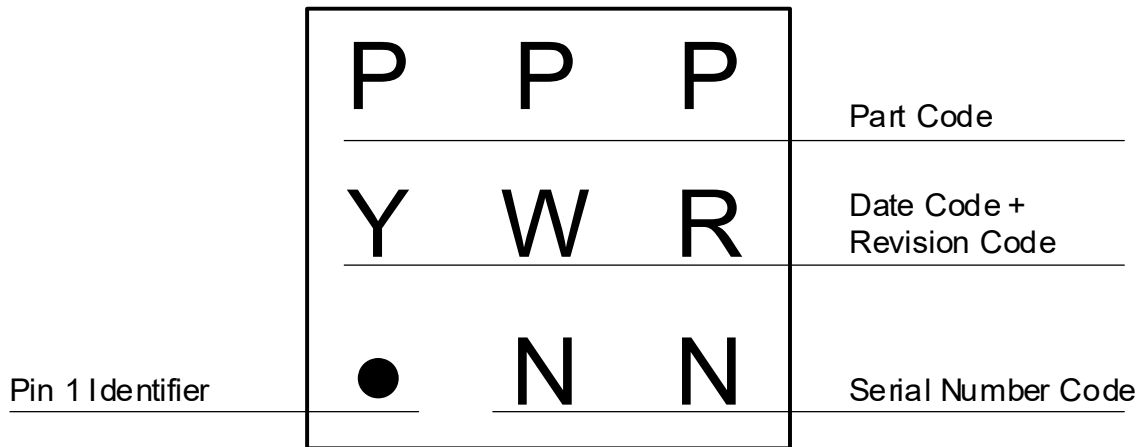

Figure 101. STQFN-14 Package Top Marking

15.3 STQFN Handling

Be sure to handle STQFN package only in a clean, ESD-safe environment. Tweezers or vacuum pick-up tools are suitable for handling. Do not handle STQFN package with fingers as this can contaminate the package pins and interface with solder reflow.

15.4 Soldering Information

Please see IPC/JEDEC J-STD-020: latest revision for reflow profile based on package volume of 2.42 mm³ (nominal) for STQFN 14L Package. More information can be found at <http://www.jedec.org>.

16. Layout Guidelines

16.1 STQFN-14L 2.0 mm x 2.2 mm 0.4P Package

 Exposed Pad
(PKG face down)

 Recommended Land Pattern
(PKG face down)

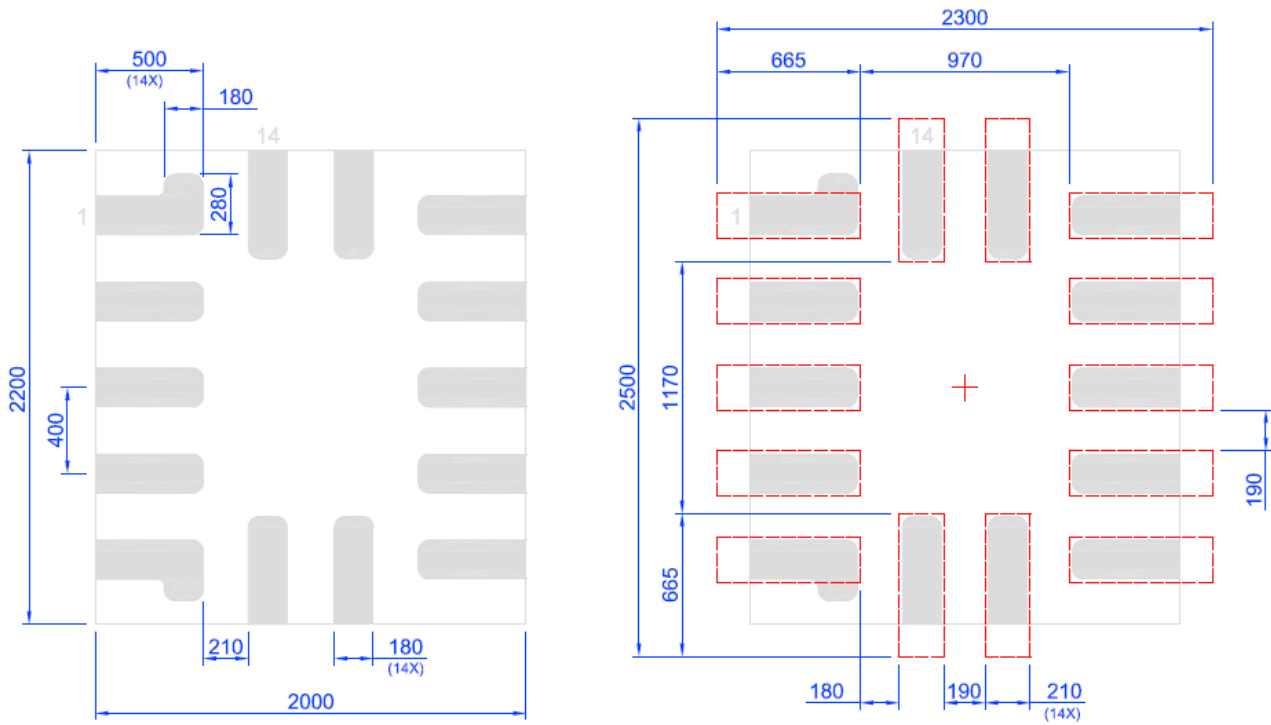

Unit:um

Figure 102. STQFN-14 Layout Example Schematic

17. Ordering Information

Part Number	Package Description	Carrier Type	Temperature Range
SLG46540V	14-pin STQFN	Tape and Reel	-40 °C to +85 °C
SLG46540V	14-pin STQFN	Tray	-40 °C to +85 °C

Note: Use SLG46540V to order. Shipments are automatically in Tape and Reel.

17.1 Tape and Reel Specifications

Package Type	# of Pins	Nominal Package Size [mm]	Max Unit		Reel and Hub [mm]	Leader (min)		Trailer (min)		Tape Width [mm]	Part Pitch [mm]
			Per Reel	Per Box		Pockets	Length [mm]	Pockets	Length [mm]		
STQFN 14L 2.0 mm x 2.2 mm 0.4P COL	14	2.0 x 2.2 x 0.55	3,000	3,000	178 / 60	100	400	100	400	8	4

17.2 Carrier Tape Drawing and Dimensions

Package Type	PocketB™ Length [mm]	PocketB™ Width [mm]	Pocket Depth [mm]	Index Hole Pitch [mm]	Pocket Pitch [mm]	Index Hole Diameter [mm]	Index Hole to Tape Edge [mm]	Index Hole to Pocket Center [mm]	Tape Width [mm]
	A0	B0	K0	P0	P1	D0	E	F	W
STQFN 14L 2.0 mm x 2.2 mm 0.4P COL	2.2	2.35	0.8	4	4	1.5	1.75	3.5	8

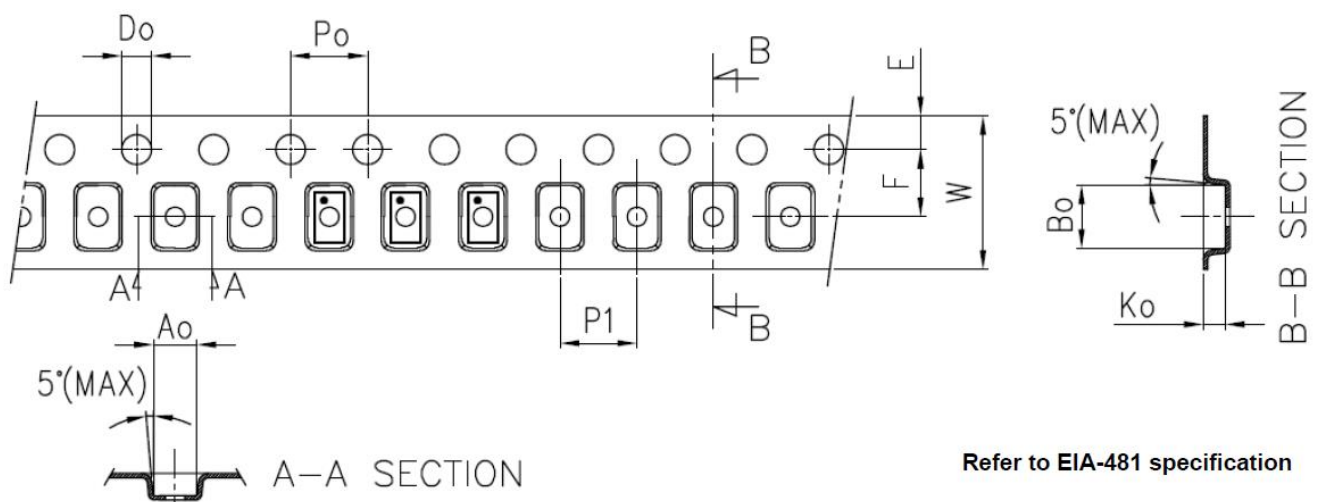

Glossary

A

ACK	Acknowledge bit
ACMP	Analog Comparator

B

BG	Bandgap
----	---------

C

CLK	Clock
CMI	Connection Matrix Input
CMO	Connection Matrix Output
CNT	Counter

D

DFF	D Flip-flop
DLY	Delay

E

ES	Electrical Specifications
ESD	Electro-static Discharge

F

FSM	Finite State Machine
-----	----------------------

G

GPI	General Purpose Input
GPIO	General Purpose Input/Output
GPO	General Purpose Output

I

IN	Input
IO	Input/Output

L

LP_BG	Low-power Bandgap
LSB	Least Significant Bit
LUT	Look-up Table

M

MSB Most Significant Bit
MUX Multiplexer

N

nRST Reset Signal (Active Low)
nSET Set Signal (Active Low)
NVM Non-volatile Memory

O

OD Open-drain
OE Output Enable
OSC Oscillator
OTP One-time Programmable
OUT Output

P

PD Power-down
P_DLY Programmable Delay
PGen Pattern Generator
POR Power-on Reset
PP Push-Pull
PWR Power

R

R/W Read/Write

S

SCL I²C Clock Input
SDA I²C Data Input/Output

V

V_{REF} Voltage Reference

W

WS Wake and Sleep Controller

Revision History

Revision	Date	Description
2.00	Apr 23, 2026	<p>Updated formatting to latest guideline.</p> <p>Changed:</p> <p>5-bit to 4-bit IO expander (Page 1)</p> <p>Figure 6. Matrix OE IO Structure Diagram (Pin 11)</p> <p>Figure 7. Matrix OE IO Structure Diagram (Pin 12)</p> <p>Figure 8. Matrix OE IO Structure Diagram (Pin 14)</p> <p>Figure 9. Matrix OE IO 4x Drive Structure Diagram (Pin 8)</p> <p>Figure 10. Matrix OE IO 4x Drive Structure Diagram (Pin 10)</p> <p>Figure 49. ACMP1 Block Diagram</p> <p>Figure 61. Voltage Reference Block Diagram</p> <p>Table 1. Pin Descriptions: Pin 8, 10, 14</p> <p>Table 3. Functional Pin Description: Pin 8, 10, 11, 12</p> <p>Section 4.1 Input Modes</p> <p>Table 5. Matrix Output Table: Register Bit Address [399:392], [407:400]</p> <p>Section 5.3 Connection Matrix Virtual Outputs</p> <p>Table 26. V_{REF} Selection Table: SEL[4:0] = 11100, 11010</p> <p>Table 29. Read/Write Protection Options</p> <p>Table 31. Register Map: Byte 00, 88, 89, 8B, 8D, 91, 92, CB, CC, CD, F0</p>
1.00	Oct 1, 2025	Initial release.

A. ECAD Design Information

This information supports the development of the PCB ECAD model for this device. It is intended to be used by PCB designers.

A.1 Part Number Indexing

This information supports the development of the PCB ECAD model for this device. It is intended to be used by PCB designers.

Orderable Part Number	Number of Pins	Package Type	Package Code/POD Number
SLG46540V	14	TQFN	

A.2 Symbol Pin Information

A.2.1 14-STQFN

Pin Number	Primary Pin Name	Primary Electrical Type	Alternate Pin Name(s)
1	V _{DD}	Power	-
2	GPI	Input	-
3	GPIO	IO	-
4	GPIO	IO	-
5	GPIO	IO	-
6	GPIO	IO	-
7	GPIO	IO	-
8	GPIO	IO	-
9	GND	Power	-
10	GPIO	IO	-
11	GPIO	IO	-
12	GPIO	IO	-
13	GPIO	IO	-
14	GPIO	IO	-

A.3 Symbol Parameters

Orderable Part Number	Qualification	Memory Type	Min Operating Temperature	Max Operating Temperature	Min Input Voltage	Max Input Voltage	Serial Interface	Number of GPI & GPIO	Number of ACMP	Maximum Number of LUTs	Pipe Delay	Maximum Counter Delay	Programmable Delay	Maximum DFF / Latch
SLG46540V	Industrial	OTP	-40 °C	85 °C	1.71 V	5.5 V	I ² C	12	3	17	16-stage	7	1	8

A.4 Footprint Design Information

IPC Footprint Type	Package Code/ POD Number	Number of Pins
QFN	QU0014AB/PSC-5047-1X-00	14

Description	Dimension	Value (mm)	Diagram
Minimum body span (vertical side)	Dmin	2.15	
Maximum body span (vertical side)	Dmax	2.25	
Minimum body span (horizontal side)	Emin	1.95	
Maximum body span (horizontal side)	Emax	2.05	
Minimum Lead Width	Bmin	0.13	
Maximum Lead Width	Bmax	0.23	
Minimum Lead Length	Lmin	0.45	
Maximum Lead Length	Lmax	0.55	
Number of pins (vertical side)	PinCountD	5	
Number of pins (horizontal side)	PinCountE	2	
Distance between the center of any two adjacent pins (vertical side)	PitchD	0.40	
Distance between the center of any two adjacent pins (horizontal side)	PitchE	0.40	
Location of pin 1; S2 = corner of D side (top left), C1 = center of E side(center).	Pin1	S2	
Maximum Height	Amax	0.60	
Minimum Standoff Height	A1min	0.00	
Minimum Lead Thickness	cmin	0.10	
Maximum Lead Thickness	cmx	0.20	

Recommended Land Pattern			Diagram
Description	Dimension	Value (mm)	
Distance between left pad toe to right pad toe (horizontal side)	ZE	2.30	
Distance between top pad toe to bottom pad toe (vertical side)	ZD	2.50	
Distance between left pad heel to right pad heel (horizontal side)	GE	0.97	
Distance between top pad heel to bottom pad heel (vertical side)	GD	1.17	
Pad Width	X	0.21	
Pad Length	Y	0.66	PCB Top View