

To our customers,

Old Company Name in Catalogs and Other Documents

On April 1st, 2010, NEC Electronics Corporation merged with Renesas Technology Corporation, and Renesas Electronics Corporation took over all the business of both companies. Therefore, although the old company name remains in this document, it is a valid Renesas Electronics document. We appreciate your understanding.

Renesas Electronics website: <http://www.renesas.com>

April 1st, 2010
Renesas Electronics Corporation

Issued by: Renesas Electronics Corporation (<http://www.renesas.com>)

Send any inquiries to <http://www.renesas.com/inquiry>.

Notice

1. All information included in this document is current as of the date this document is issued. Such information, however, is subject to change without any prior notice. Before purchasing or using any Renesas Electronics products listed herein, please confirm the latest product information with a Renesas Electronics sales office. Also, please pay regular and careful attention to additional and different information to be disclosed by Renesas Electronics such as that disclosed through our website.
2. Renesas Electronics does not assume any liability for infringement of patents, copyrights, or other intellectual property rights of third parties by or arising from the use of Renesas Electronics products or technical information described in this document. No license, express, implied or otherwise, is granted hereby under any patents, copyrights or other intellectual property rights of Renesas Electronics or others.
3. You should not alter, modify, copy, or otherwise misappropriate any Renesas Electronics product, whether in whole or in part.
4. Descriptions of circuits, software and other related information in this document are provided only to illustrate the operation of semiconductor products and application examples. You are fully responsible for the incorporation of these circuits, software, and information in the design of your equipment. Renesas Electronics assumes no responsibility for any losses incurred by you or third parties arising from the use of these circuits, software, or information.
5. When exporting the products or technology described in this document, you should comply with the applicable export control laws and regulations and follow the procedures required by such laws and regulations. You should not use Renesas Electronics products or the technology described in this document for any purpose relating to military applications or use by the military, including but not limited to the development of weapons of mass destruction. Renesas Electronics products and technology may not be used for or incorporated into any products or systems whose manufacture, use, or sale is prohibited under any applicable domestic or foreign laws or regulations.
6. Renesas Electronics has used reasonable care in preparing the information included in this document, but Renesas Electronics does not warrant that such information is error free. Renesas Electronics assumes no liability whatsoever for any damages incurred by you resulting from errors in or omissions from the information included herein.
7. Renesas Electronics products are classified according to the following three quality grades: “Standard”, “High Quality”, and “Specific”. The recommended applications for each Renesas Electronics product depends on the product’s quality grade, as indicated below. You must check the quality grade of each Renesas Electronics product before using it in a particular application. You may not use any Renesas Electronics product for any application categorized as “Specific” without the prior written consent of Renesas Electronics. Further, you may not use any Renesas Electronics product for any application for which it is not intended without the prior written consent of Renesas Electronics. Renesas Electronics shall not be in any way liable for any damages or losses incurred by you or third parties arising from the use of any Renesas Electronics product for an application categorized as “Specific” or for which the product is not intended where you have failed to obtain the prior written consent of Renesas Electronics. The quality grade of each Renesas Electronics product is “Standard” unless otherwise expressly specified in a Renesas Electronics data sheets or data books, etc.
 - “Standard”: Computers; office equipment; communications equipment; test and measurement equipment; audio and visual equipment; home electronic appliances; machine tools; personal electronic equipment; and industrial robots.
 - “High Quality”: Transportation equipment (automobiles, trains, ships, etc.); traffic control systems; anti-disaster systems; anti-crime systems; safety equipment; and medical equipment not specifically designed for life support.
 - “Specific”: Aircraft; aerospace equipment; submersible repeaters; nuclear reactor control systems; medical equipment or systems for life support (e.g. artificial life support devices or systems), surgical implantations, or healthcare intervention (e.g. excision, etc.), and any other applications or purposes that pose a direct threat to human life.
8. You should use the Renesas Electronics products described in this document within the range specified by Renesas Electronics, especially with respect to the maximum rating, operating supply voltage range, movement power voltage range, heat radiation characteristics, installation and other product characteristics. Renesas Electronics shall have no liability for malfunctions or damages arising out of the use of Renesas Electronics products beyond such specified ranges.
9. Although Renesas Electronics endeavors to improve the quality and reliability of its products, semiconductor products have specific characteristics such as the occurrence of failure at a certain rate and malfunctions under certain use conditions. Further, Renesas Electronics products are not subject to radiation resistance design. Please be sure to implement safety measures to guard them against the possibility of physical injury, and injury or damage caused by fire in the event of the failure of a Renesas Electronics product, such as safety design for hardware and software including but not limited to redundancy, fire control and malfunction prevention, appropriate treatment for aging degradation or any other appropriate measures. Because the evaluation of microcomputer software alone is very difficult, please evaluate the safety of the final products or system manufactured by you.
10. Please contact a Renesas Electronics sales office for details as to environmental matters such as the environmental compatibility of each Renesas Electronics product. Please use Renesas Electronics products in compliance with all applicable laws and regulations that regulate the inclusion or use of controlled substances, including without limitation, the EU RoHS Directive. Renesas Electronics assumes no liability for damages or losses occurring as a result of your noncompliance with applicable laws and regulations.
11. This document may not be reproduced or duplicated, in any form, in whole or in part, without prior written consent of Renesas Electronics.
12. Please contact a Renesas Electronics sales office if you have any questions regarding the information contained in this document or Renesas Electronics products, or if you have any other inquiries.

(Note 1) “Renesas Electronics” as used in this document means Renesas Electronics Corporation and also includes its majority-owned subsidiaries.

(Note 2) “Renesas Electronics product(s)” means any product developed or manufactured by or for Renesas Electronics.

4-BIT SINGLE-CHIP MICROCONTROLLER WITH DEDICATED HARDWARE FOR DIGITAL TUNING SYSTEM

DESCRIPTION

The μPD17P709A is produced by replacing the on-chip mask ROM of the μPD17704A, 17705A, 17707A, 17708A, and 17709A with a one-time PROM.

The μPD17P709A allows programs to be written once, so the μPD17P709A is suitable for preproduction in μPD17704A, 17705A, 17707A, 17708A, or 17709A system development or low-volume production.

When reading this document, also refer to the publications on the μPD17704A, 17705A, 17707A, 17708A, or 17709A.

The electrical characteristics (including power supply current) and PLL analog characteristics of the μPD17P709A differ from those of the μPD17704A, 17705A, 17707A, 17708A, and 17709A. In high-volume application set production, be sure to carefully check these differences.

FEATURES

- Compatible with the μPD17704A, 17705A, 17707A, 17708A, and 17709A
- On-chip one-time PROM: 32 KB (16384 × 16 bits)
- Supply voltage: $V_{DD} = 5\text{ V} \pm 10\%$

ORDERING INFORMATION

Part Number	Package
μPD17P709AGC-3B9	80-pin plastic QFP (14 × 14)

The information in this document is subject to change without notice. Before using this document, please confirm that this is the latest version.
Not all devices/types available in every country. Please check with local NEC representative for availability and additional information.

FUNCTIONAL OUTLINE

(1/2)

Item		Part Number					
		μPD17704A	μPD17705A	μPD17707A	μPD17708A	μPD17709A	μPD17P709A
Program memory (ROM)		8192 × 16 bits (mask ROM)	12288 × 16 bits (mask ROM)		16384 × 16 bits (mask ROM)		16384 × 16 bits (one-time PROM)
General-purpose data memory (RAM)		672 × 4 bits		1120 × 4 bits		1176 × 4 bits	
Instruction execution time		1.78 μs (with f _x = 4.5 MHz crystal oscillator)					
General-purpose ports		<ul style="list-style-type: none"> I/O ports: 46 Input ports: 12 Output ports: 4 					
Stack levels		<ul style="list-style-type: none"> Address stack: 15 levels Interrupt stack: 4 levels DBF stack: 4 levels (can be manipulated via software) 					
Interrupts		<ul style="list-style-type: none"> External: 6 sources (falling edge of CE pin, INT0 to INT4) Internal: 6 sources (timers 0 to 3, serial interfaces 0 and 1) 					
Timer		5 channels <ul style="list-style-type: none"> Basic timer (clock: 10, 20, 50, 100 Hz): 1 channel 8-bit timer with gate counter (clock: 1 k, 2 k, 10 k, 100 kHz): 1 channel 8-bit timer (clock: 1 kHz, 2 kHz, 10 kHz, 100 kHz): 2 channels 8-bit timer multiplexed with PWM (clock: 440 Hz, 4.4 kHz): 1 channel 					
A/D converter		8 bits × 6 channels (hardware mode and software mode selectable)					
D/A converter (PWM)		3 channels (8-bit or 9-bit resolution selectable by software) Output frequency: 4.4 kHz, 440 Hz (with 8-bit PWM selected) 2.2 kHz, 220 Hz (with 9-bit PWM selected)					
Serial interface		2 units (3 channels) <ul style="list-style-type: none"> 3-wire serial I/O: 2 channels 2-wire serial I/O/I²C bus: 1 channel 					
PLL	Division mode	<ul style="list-style-type: none"> Direct division mode (VCOL pin (MF mode): 0.5 to 3 MHz) Pulse swallow mode (VCOL pin (HF mode): 10 to 40 MHz) (VCOH pin (VHF mode): 60 to 130 MHz) 					
	Reference frequency	13 types selectable (1, 1.25, 2.5, 3, 5, 6.25, 9, 10, 12.5, 18, 20, 25, 50 kHz)					
	Charge pump	Two error-out output pins (EO0, EO1)					
	Phase comparator	Unlock status detectable by program					
Intermediate frequency counter		<ul style="list-style-type: none"> Intermediate frequency (IF) measurement P1C0/FMIFC pin: 10 to 11 MHz in FMIF mode 0.4 to 0.5 MHz in AMIF mode P1C1/AMIFC pin: 0.4 to 0.5 MHz in AMIF mode External gate width measurement P2A1/FCG1, P2A0/FCG0 pin 					
BEEP output		2 pins Output frequency: 1 kHz, 3 kHz, 4 kHz, 6.7 kHz (BEEP0 pin) 67 Hz, 200 Hz, 3 kHz, 4 kHz (BEEP1 pin)					

(2/2)

Item \ Part Number	μPD17704A	μPD17705A	μPD17707A	μPD17708A	μPD17709A	μPD17P709A
Reset	<ul style="list-style-type: none"> • Power-on reset (on power application) • Reset by $\overline{\text{RESET}}$ pin • Watchdog timer reset Can be set only once on power application: 65536 instructions, 131072 instructions, or no-use selectable • Stack pointer overflow/underflow reset Can be set only once on power application: interrupt stack or address stack selectable • CE reset (CE pin low → high level) CE reset delay timing can be set. • Power failure detection function 					
Standby	<ul style="list-style-type: none"> • Clock stop mode (STOP) • Halt mode (HALT) 					
Supply voltage	<ul style="list-style-type: none"> • PLL operation: $V_{DD} = 4.5$ to 5.5 V • CPU operation: $V_{DD} = 3.5$ to 5.5 V 					
Package	80-pin plastic QFP (14 × 14)					

PIN CONFIGURATION (TOP VIEW)

80-pin plastic QFP (14 × 14)

μPD17P709AGC-3B9

(1) Normal operation mode

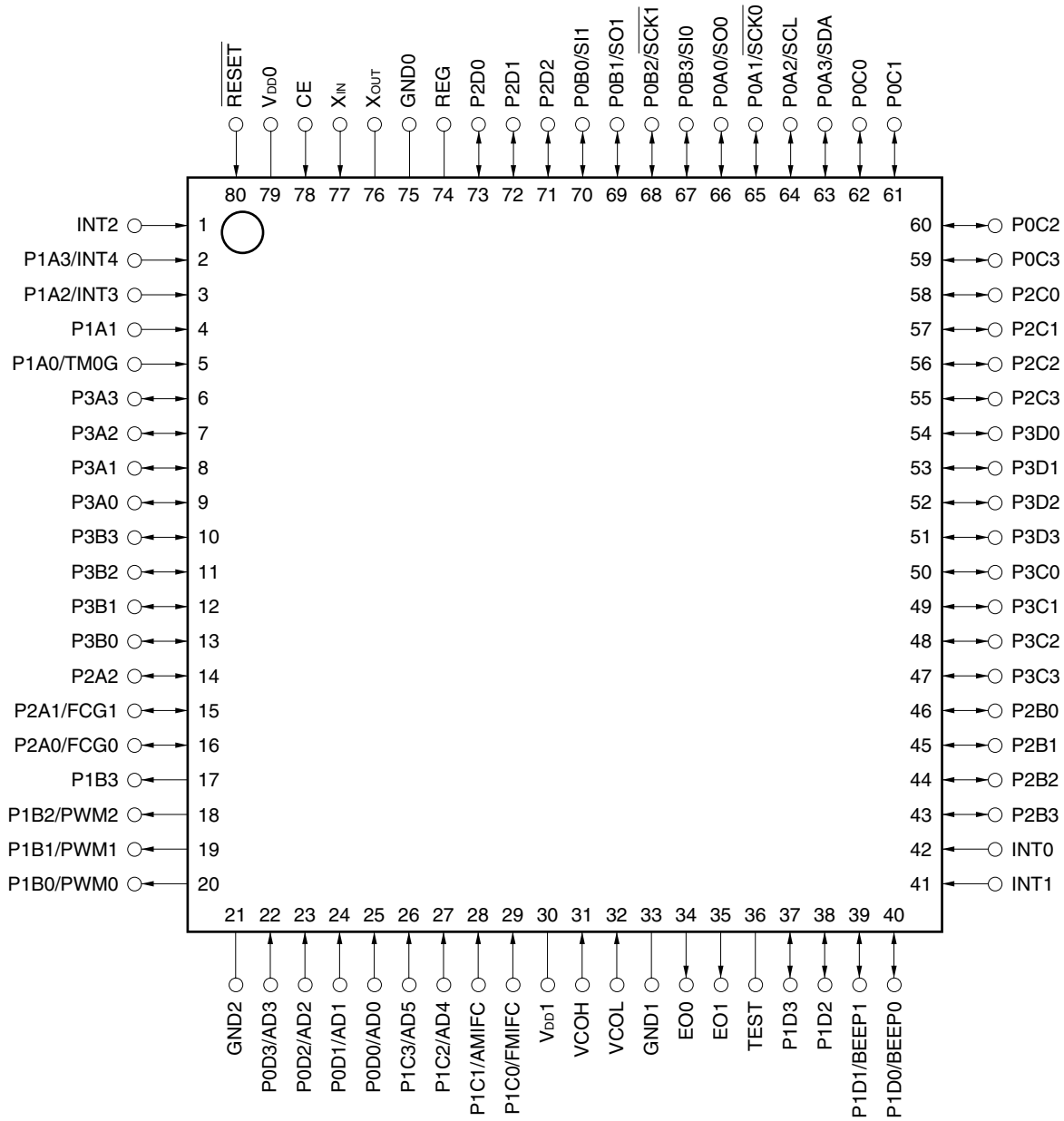

(2) PROM programming mode

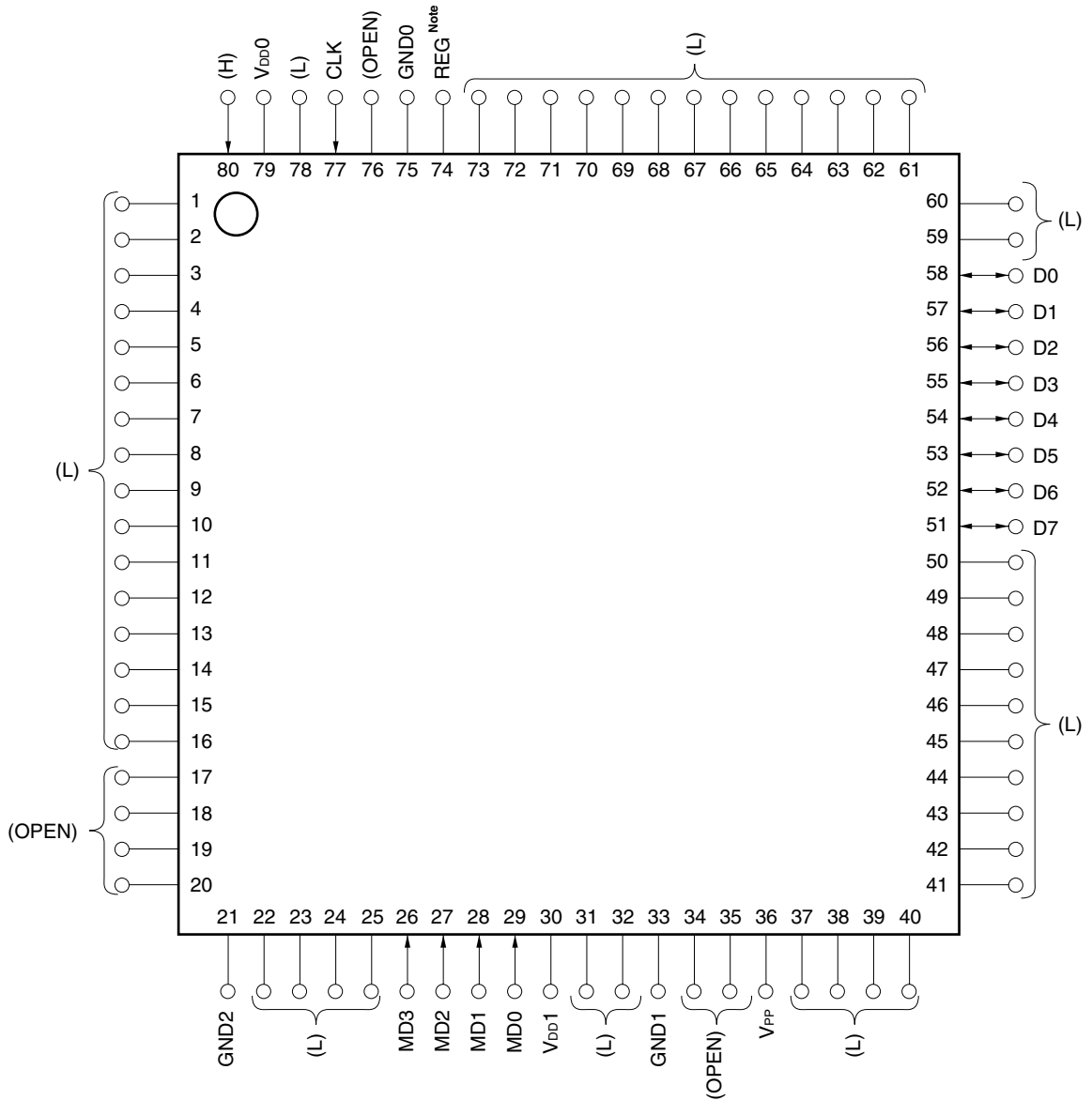

Note Connect to the same potential as V_{DD}.

Caution The items in parentheses indicate the processing of pins not used in the PROM programming mode.

L: Independently connect to GND via a resistor (470 Ω)

H: Independently connect each pin to V_{DD} via a resistor (470 Ω)

OPEN: Leave open.

PIN NAMES

AD0 to AD5:	A/D converter input	P2B0 to P2B3:	Port 2B
AMIFC:	AM frequency counter input	P2C0 to P2C3:	Port 2C
BEEP0, BEEP1:	BEEP output	P2D0 to P2D2:	Port 2D
CE:	Chip enable	P3A0 to P3A3:	Port 3A
CLK:	Address update clock input	P3B0 to P3B3:	Port 3B
D0 to D7:	Data I/O	P3C0 to P3C3:	Port 3C
EO0, EO1:	Error-out output	P3D0 to P3D3:	Port 3D
FCG0, FGC1:	Frequency counter gate input	REG:	CPU regulator
FMIFC:	FM frequency counter input	<u>RESET</u> :	Reset input
GND0 to GND2:	Ground 0 to 2	<u>SCK0</u> , <u>SCK1</u> :	3-wire serial clock I/O
INT0 to INT4:	External interrupt input	SCL:	2-wire serial clock I/O
MD0 to MD3:	Operation mode selection	SDA:	2-wire serial data I/O
PWM0 to PWM2:	D/A converter output	SI0, SI1:	3-wire serial data input
P0A0 to P0A3:	Port 0A	SO0, SO1:	3-wire serial data output
P0B0 to P0B3:	Port 0B	TEST:	Test input
P0C0 to P0C3:	Port 0C	TM0G:	Timer 0 gate input
P0D0 to P0D3:	Port 0D	VCOH:	Local oscillation high input
P1A0 to P1A3:	Port 1A	VCOL:	Local oscillation low input
P1B0 to P1B3:	Port 1B	VDD0, VDD1:	Power supply
P1C0 to P1C3:	Port 1C	VPP:	Program voltage application
P1D0 to P1D3:	Port 1D	XIN, XOUT:	Main clock oscillation
P2A0 to P2A2:	Port 2A		

BLOCK DIAGRAM

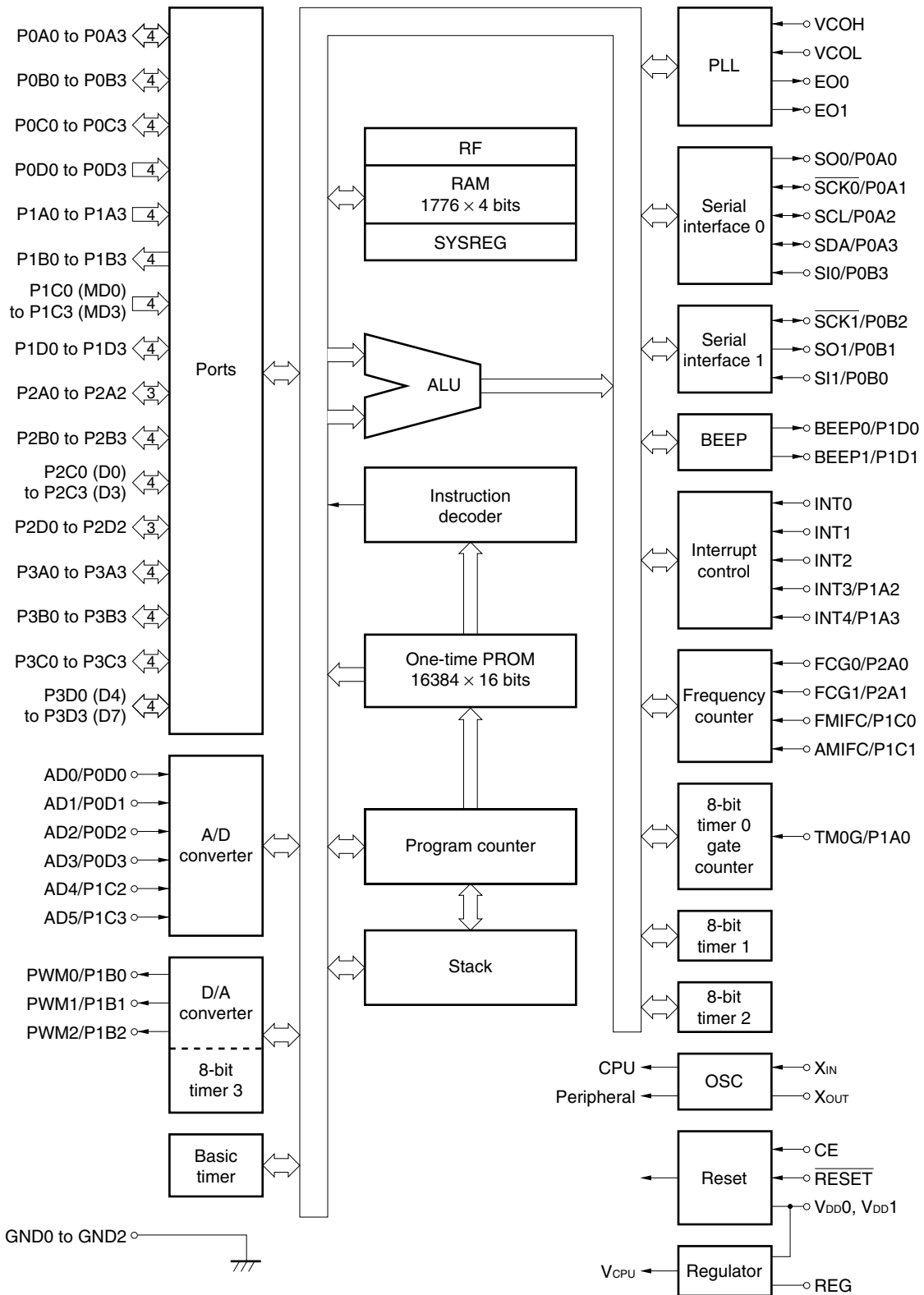

Remark Pins in parentheses are used in PROM programming mode.

CONTENTS

1. PIN FUNCTIONS 9

 1.1 Pin Function List 9

 1.2 PROM Programming Mode 13

 1.3 Equivalent Circuits of Pins 14

 1.4 Connections of Unused Pins 19

 1.5 Cautions on Using CE, INT0 to INT4, and $\overline{\text{RESET}}$ Pins
 (Only in Normal Operation Mode) 21

 1.6 Cautions on Using TEST Pin (Only in Normal Operation Mode) 21

2. ONE-TIME PROM (PROGRAM MEMORY) WRITE, READ, AND VERIFY 22

 2.1 Operation Modes for Program Memory Write, Read and Verify 23

 2.2 Program Memory Write Procedure 24

 2.3 Program Memory Read Procedure 25

3. ELECTRICAL SPECIFICATIONS26

4. PACKAGE DRAWING31

5. RECOMMENDED SOLDERING CONDITIONS32

APPENDIX DEVELOPMENT TOOLS33

1. PIN FUNCTIONS

1.1 Pin Function List

Pin No.	Symbol	Function	Output Form		
1 41 42	INT2 INT1 INT0	Edge-detectable vectored interrupt input pins. Rising or falling edge can be specified.	–		
2 3 4 5	P1A3/INT4 P1A2/INT3 P1A1 P1A0/TM0G	<p>Port 1A multiplexed with external interrupt request signal input and event signal input pins.</p> <ul style="list-style-type: none"> • P1A3 to P1A0 • 4-bit input port • INT4, INT3 • Edge-detectable vectored interrupt • TM0G • Input for gate of 8-bit timer 0 	–		
		After reset	With clock stopped		
		Power-on reset		WDT&SP reset	CE reset
		Input (P1A3 to P1A0)		Input (P1A3 to P1A0)	Retained
6 9	P3A3 P3A0	<p>4-bit I/O port.</p> <p>Input or output can be specified in 4-bit units.</p>	CMOS push-pull		
		After reset	With clock stopped		
		Power-on reset		WDT&SP reset	CE reset
		Input		Input	Retained
10 13	P3B3 P3B0	<p>4-bit I/O port.</p> <p>Input or output can be specified in 4-bit units.</p>	CMOS push-pull		
		After reset	With clock stopped		
		Power-on reset		WDT&SP reset	CE reset
		Input		Input	Retained
14 15 16	P2A2 P2A1/FCG1 P2A0/FCG0	<p>Port 2A multiplexed with external gate counter input pins.</p> <ul style="list-style-type: none"> • P2A2 to P2A0 • 3-bit I/O port • Input or output can be specified in 1-bit units. • FCG1, FCG0 • Input for external gate counter 	CMOS push-pull		
		After reset	With clock stopped		
		Power-on reset		WDT&SP reset	CE reset
		Input (P2A2 to P2A0)		Input (P2A2 to P2A0)	Retained (P2A2 to P2A0)

Pin No.	Symbol	Function	Output Form	
17 18 20	P1B3 P1B2/PWM2 P1B0/PWM0	<p>Port 1B multiplexed with D/A converter output pins.</p> <ul style="list-style-type: none"> • P1B3 to P1B0 • 4-bit output port • PWM2 to P2M0 • 8- or 9-bit D/A converter output 	N-ch open-drain (12 V withstanding voltage)	
After reset				With clock stopped
Power-on reset	WDT&SP reset	CE reset		
Outputs low level (P1B3 to P1B0)	Outputs low level (P1B3 to P1B0)	Retained		Retained (P1B3 to P1B0)
21 33 75	GND2 GND1 GND0	Ground	–	
22 25	P0D3/AD3 P0D0/AD0	<p>Port 0D multiplexed with A/D converter input pins</p> <ul style="list-style-type: none"> • P0D3 to P0D0 • 4-bit input port • Pull-down resistors can be connected in 1-bit units. • AD3 to AD0 • Analog input of A/D converter with 8-bit resolution 	–	
After reset				With clock stopped
Power-on reset	WDT&SP reset	CE reset		
Input with pull-down resistor (P0D3 to P0D0)	Input with pull-down resistor (P0D3 to P0D0)	Retained		Retained
26 27 28 29	P1C3/AD5 P1C2/AD4 P1C1/AMIFC P1C0/FMIFC	<p>Port 1C multiplexed with A/D converter input and IF counter input pins.</p> <ul style="list-style-type: none"> • P1C3 to P1C0 • 4-bit input port • AD5, AD4 • Analog input to A/D converter with 8-bit resolution • FMIFC, AMIFC • Input to frequency counter 	–	
After reset				With clock stopped
Power-on reset	WDT&SP reset	CE reset		
Input (P1C3 to P1C0)	Input (P1C3 to P1C0)	<ul style="list-style-type: none"> • P1C3/AD5, P1C2/AD4 Retained • P1C1/AMIFC, P1C0/FMIFC Input (P1C1, P1C0) 		<ul style="list-style-type: none"> • P1C3/AD5, P1C2/AD4 Retained • P1C1/AMIFC, P1C0/FMIFC Input (P1C1, P1C0)

Pin No.	Symbol	Function	Output Form											
30 79	V _{DD1} V _{DD0}	Power supply. Supply the same voltage to these pins. <ul style="list-style-type: none"> • With CPU and peripheral function operating: 4.5 to 5.5 V • With CPU operating: 3.5 to 5.5 V • With clock stopped: 2.2 to 5.5 V 	–											
31 32	VCOH VCOL	PLL local oscillation (VCO) frequency input. <ul style="list-style-type: none"> • VCOH <ul style="list-style-type: none"> • Active with VHF mode selected by program; otherwise, pulled down. • VCOL <ul style="list-style-type: none"> • Active with HF or MW mode selected by program; otherwise, pulled down. <p>Because the input of these pins goes into an AC amplifier, cut the DC component of the input signal with a capacitor.</p>	–											
34 35	EO0 EO1	Output from charge pump of PLL frequency synthesizer. Outputs the divided frequency of local oscillation and the result of comparison of the phase difference of the reference frequency. <table border="1" style="width: 100%; margin-top: 10px;"> <tr> <td colspan="3" style="text-align: center;">After reset</td> <td rowspan="2" style="text-align: center;">With clock stopped</td> </tr> <tr> <td style="text-align: center;">Power-on reset</td> <td style="text-align: center;">WDT&SP reset</td> <td style="text-align: center;">CE reset</td> </tr> <tr> <td style="text-align: center;">High-impedance output</td> <td style="text-align: center;">High-impedance output</td> <td style="text-align: center;">High-impedance output</td> <td style="text-align: center;">High-impedance output</td> </tr> </table>	After reset			With clock stopped	Power-on reset	WDT&SP reset	CE reset	High-impedance output	High-impedance output	High-impedance output	High-impedance output	CMOS 3-state
After reset			With clock stopped											
Power-on reset	WDT&SP reset	CE reset												
High-impedance output	High-impedance output	High-impedance output	High-impedance output											
36	TEST	Test input pin. Be sure to connect this pin to GND.	–											
37 38 39 40	P1D3 P1D2 P1D1/BEEP1 P1D0/BEEP0	Port 1D and BEEP output. <ul style="list-style-type: none"> • P1D3 to P1D0 <ul style="list-style-type: none"> • 4-bit I/O port • Input or output can be specified in 1-bit units. • BEEP1, BEEP0 <ul style="list-style-type: none"> • BEEP output <table border="1" style="width: 100%; margin-top: 10px;"> <tr> <td colspan="3" style="text-align: center;">After reset</td> <td rowspan="2" style="text-align: center;">With clock stopped</td> </tr> <tr> <td style="text-align: center;">Power-on reset</td> <td style="text-align: center;">WDT&SP reset</td> <td style="text-align: center;">CE reset</td> </tr> <tr> <td style="text-align: center;">Input (P1D3 to P1D0)</td> <td style="text-align: center;">Input (P1D3 to P1D0)</td> <td style="text-align: center;">Retained (P1D3 to P1D0)</td> <td style="text-align: center;">Retained (P1D3 to P1D0)</td> </tr> </table>	After reset			With clock stopped	Power-on reset	WDT&SP reset	CE reset	Input (P1D3 to P1D0)	Input (P1D3 to P1D0)	Retained (P1D3 to P1D0)	Retained (P1D3 to P1D0)	CMOS push-pull
After reset			With clock stopped											
Power-on reset	WDT&SP reset	CE reset												
Input (P1D3 to P1D0)	Input (P1D3 to P1D0)	Retained (P1D3 to P1D0)	Retained (P1D3 to P1D0)											
43 46	P2B3 P2B0	4-bit I/O port. Input or output can be specified in 1-bit units. <table border="1" style="width: 100%; margin-top: 10px;"> <tr> <td colspan="3" style="text-align: center;">After reset</td> <td rowspan="2" style="text-align: center;">With clock stopped</td> </tr> <tr> <td style="text-align: center;">Power-on reset</td> <td style="text-align: center;">WDT&SP reset</td> <td style="text-align: center;">CE reset</td> </tr> <tr> <td style="text-align: center;">Input</td> <td style="text-align: center;">Input</td> <td style="text-align: center;">Retained</td> <td style="text-align: center;">Retained</td> </tr> </table>	After reset			With clock stopped	Power-on reset	WDT&SP reset	CE reset	Input	Input	Retained	Retained	CMOS push-pull
After reset			With clock stopped											
Power-on reset	WDT&SP reset	CE reset												
Input	Input	Retained	Retained											
47 50	P3C3 P3C0	4-bit I/O port. Input or output can be specified in 4-bit units. <table border="1" style="width: 100%; margin-top: 10px;"> <tr> <td colspan="3" style="text-align: center;">After reset</td> <td rowspan="2" style="text-align: center;">With clock stopped</td> </tr> <tr> <td style="text-align: center;">Power-on reset</td> <td style="text-align: center;">WDT&SP reset</td> <td style="text-align: center;">CE reset</td> </tr> <tr> <td style="text-align: center;">Input</td> <td style="text-align: center;">Input</td> <td style="text-align: center;">Retained</td> <td style="text-align: center;">Retained</td> </tr> </table>	After reset			With clock stopped	Power-on reset	WDT&SP reset	CE reset	Input	Input	Retained	Retained	CMOS push-pull
After reset			With clock stopped											
Power-on reset	WDT&SP reset	CE reset												
Input	Input	Retained	Retained											

Pin No.	Symbol	Function	Output Form		
51 54	P3D3 P3D0	4-bit I/O port. Input or output can be specified in 4-bit units.	CMOS push-pull		
		After reset		With clock stopped	
		Power-on reset			WDT&SP reset
		Input		Input	Retained
55 58	P2C3 P2C0	4-bit I/O port. Input or output can be specified in 4-bit units.	CMOS push-pull		
		After reset		With clock stopped	
		Power-on reset			WDT&SP reset
		Input		Input	Retained
59 62	P0C3 P0C0	4-bit I/O port. Input or output can be specified in 4-bit units.	CMOS push-pull		
		After reset		With clock stopped	
		Power-on reset			WDT&SP reset
		Input		Input	Retained
63 64	P0A3/DSA P0A2/SCL	Ports P0A and P0B are multiplexed with I/O of serial interface. <ul style="list-style-type: none"> P0A3 to P0A0 <ul style="list-style-type: none"> 4-bit I/O port Input or output can be specified in 1-bit units. P0B3 to P0B0 <ul style="list-style-type: none"> 4-bit I/O port Input or output can be specified in 1-bit units. SDA, SCL <ul style="list-style-type: none"> Serial data and serial clock I/O of serial interface 0 in 2-wire serial I/O or I²C bus mode SCK0, SO0, SI0 <ul style="list-style-type: none"> Serial clock I/O, serial data output, and serial data input of serial interface 0 in 3-wire serial I/O mode SCK1, SO1, SI1 <ul style="list-style-type: none"> Serial clock I/O, serial data output, serial data input of serial interface 1 in 3-wire serial I/O mode 	N-ch open-drain		
65 66 67 68 69 70	P0A1/ $\overline{\text{SCK0}}$ P0A0/SO0 P0B3/SI0 P0B2/ $\overline{\text{SCK1}}$ P0B1/SO1 P0B0/SI1	<ul style="list-style-type: none"> P0A3 to P0A0 <ul style="list-style-type: none"> 4-bit I/O port Input or output can be specified in 1-bit units. P0B3 to P0B0 <ul style="list-style-type: none"> 4-bit I/O port Input or output can be specified in 1-bit units. SDA, SCL <ul style="list-style-type: none"> Serial data and serial clock I/O of serial interface 0 in 2-wire serial I/O or I²C bus mode SCK0, SO0, SI0 <ul style="list-style-type: none"> Serial clock I/O, serial data output, and serial data input of serial interface 0 in 3-wire serial I/O mode SCK1, SO1, SI1 <ul style="list-style-type: none"> Serial clock I/O, serial data output, serial data input of serial interface 1 in 3-wire serial I/O mode 	CMOS push-pull		
		After reset	With clock stopped		
		Power-on reset	WDT&SP reset	CE reset	
		Input (P0A3 to P0A0, P0B3 to P0B0)	Input (P0A3 to P0A0, P0B3 to P0B0)	Retained (P0A3 to P0A0, P0B3 to P0B0)	Retained (P0A3 to P0A0, P0B3 to P0B0)
71 73	P2D2 P2D0	3-bit I/O port. Input or output can be specified in 1-bit units.	CMOS push-pull		
		After reset		With clock stopped	
		Power-on reset			WDT&SP reset
		Input		Input	Retained

Pin No.	Symbol	Function	Output Form
74	REG	CPU regulator. Connect this pin to GND via 0.1 μF capacitor.	–
76 77	X _{OUT} X _{IN}	Ground pins of crystal resonator.	–
78	CE	Device operation selection, CE reset, and interrupt signal input pin. <ul style="list-style-type: none"> • Device operation selection When CE is high, the PLL frequency synthesizer can operate. When CE is low, the PLL frequency synthesizer is automatically disabled internally. • CE reset When CE goes high, the device is reset at the rising edge of the internal basic timer setting pulse. This pin also has a reset timing delay function. • Interrupt A vectored interrupt occurs at the falling edge of this pin. 	–
80	<u>RESET</u>	Reset input	–

1.2 PROM Programming Mode

Pin No.	Symbol	Function	Output Form
26 29	MD3 MD0	Input for operating mode selection for program memory write, read, or verify.	–
21 33 75	GND2 GND1 GND0	Ground	–
36	V _{PP}	Pin to which program voltage is applied during program memory write, read, or verify. +12.5 V is applied.	–
30 79	V _{DD1} V _{DD0}	Power supply pins. +6 V is applied during program memory write, read, or verify.	–
51 58	D7 D0	8-bit data I/O for program memory write, read, or verify	CMOS push-pull
77	CLK	Clock input for address updating during program memory write, read, or verify	–

Remark The pins other than those listed above are not used in PROM programming mode. For the handling of the unused pins, see **PIN CONFIGURATION (2) PROM programming mode**.

1.3 Equivalent Circuits of Pins

- (1) P0A (P0A1/SCK0, P0A0/SO0)
 - P0B (P0B3/SI0, P0B2/SCK1, P0B1/SO1, P0B0/SI1)
 - P0C (P0C3, P0C2, P0C1, P0C0)
 - P1D (P1D3, P1D2, P1D1/BEEP1, P1D0/BEEP0)
 - P2A (P2A2, P2A1/FCG1, P2A0/FCG0)
 - P2B (P2B3, P2B2, P2B1, P2B0)
 - P2C (P2C3, P2C2, P2C1, P2C0)
 - P2D (P2D2, P2D1, P2D0)
 - P3A (P3A3, P3A2, P3A1, P3A0)
 - P3B (P3B3, P3B2, P3B1, P3B0)
 - P3C (P3C3, P3C2, P3C1, P3C0)
 - P3D (P3D3, P3D2, P3D1, P3D0)
- } (I/O)

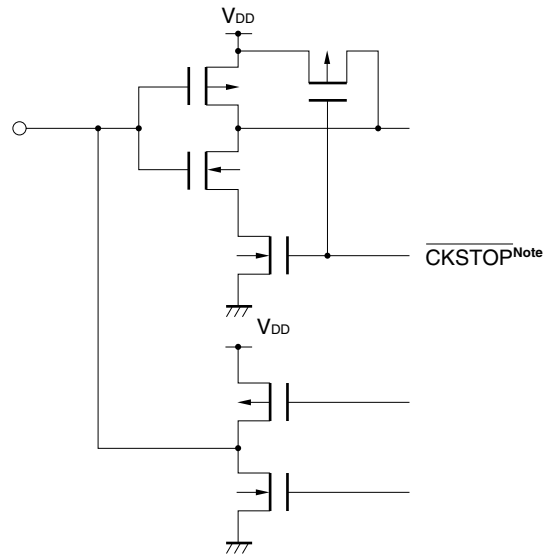

Note This is an internal signal that is output when the clock stop instruction is executed. Its circuit is designed not to increase the current consumption due to noise even if it is floated.

(2) P0A (P0A3/SDA, P0A2/SCL) (I/O)

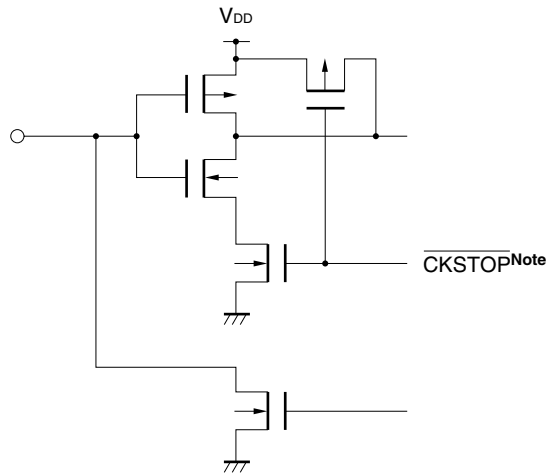

Note This is an internal signal that is output when the clock stop instruction is executed. Its circuit is designed not to increase the current consumption due to noise even if it is floated.

(3) P1B (P1B3, P1B2/PWM2, P1B1/PWM1, P1B0/PWM0) (output)

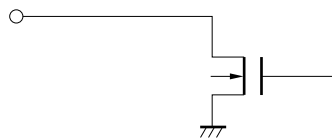

(4) P0D (P0D3/AD3, P0D2/AD2, P0D1/AD1, P0D0/AD0) (input)

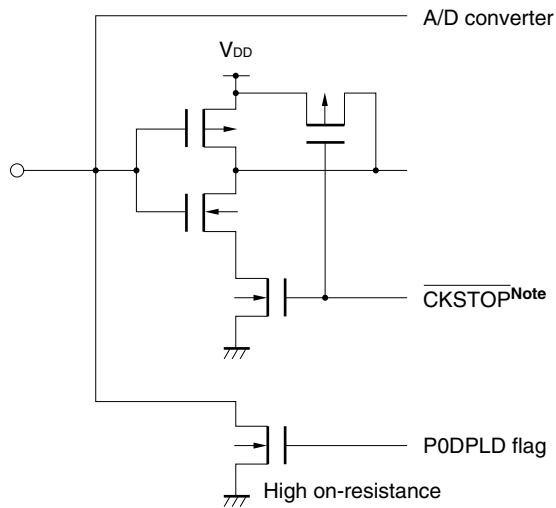

Note This is an internal signal that is output when the clock stop instruction is executed. Its circuit is designed not to increase the current consumption due to noise even if it is floated.

(5) P1A (P1A1) (input)

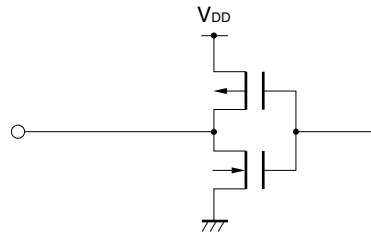

(6) P1C (P1C3/AD5, P1C2/AD4) (input)

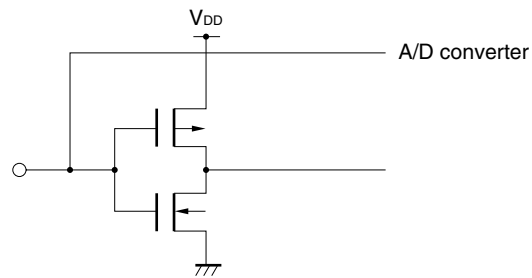

(7) P1C (P1C1/AMIFC, P1C0/FMIFC) (input)

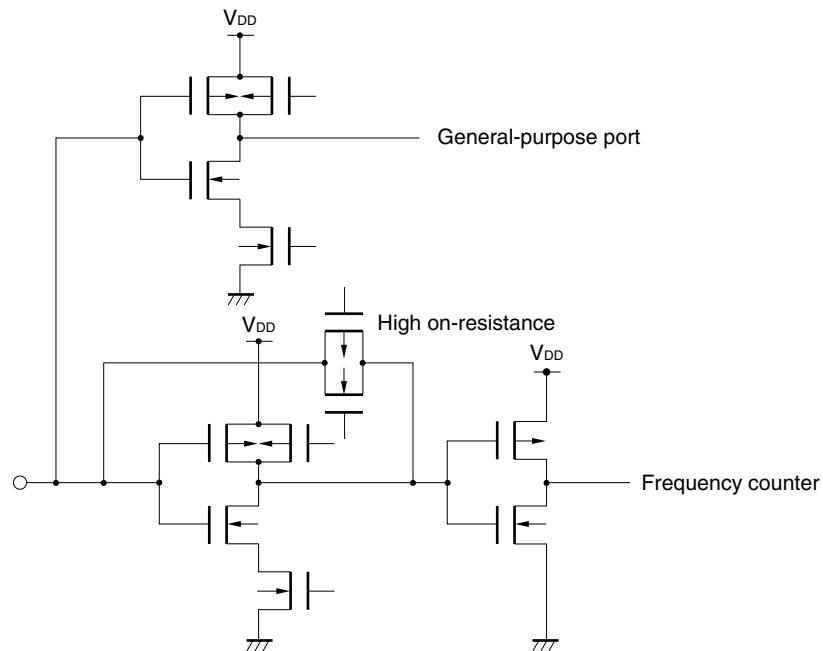

- (8) CE
 - RESET
 - INT0, INT1, INT2
 - P1A (P1A3/INT4, P1A2/INT3, P1A0/TM0G)
- } (Schmitt-triggered input)

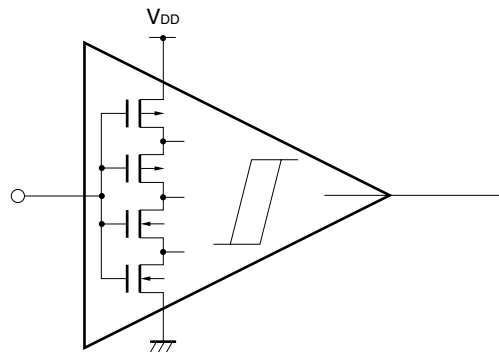

- (9) XOUT (output), XIN (input)

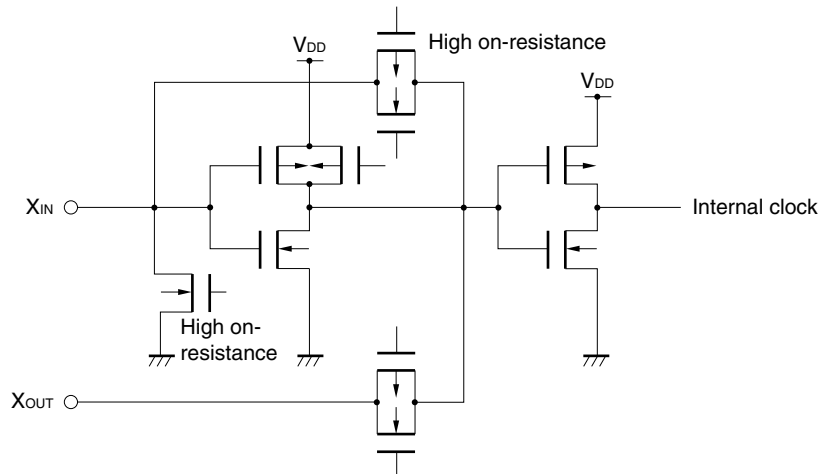

- (10) EO1, EO0 (output)

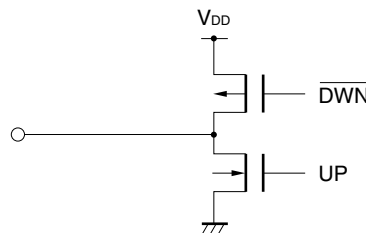

(11) VCOH, VCOL (input)

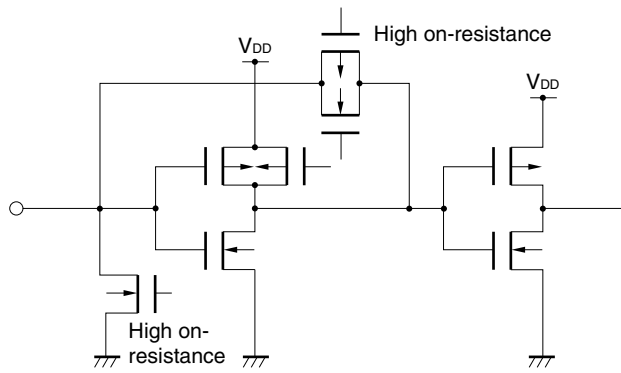

1.4 Connections of Unused Pins

It is recommended to connect unused pins as follows.

Table 1-1. Connections of Unused Pins

(1/2)

Port pin	Pin Name	I/O Mode	Recommended Connection		
	P0D3/AD3 to P0D0/AD0	Input	Independently connect to GND via a resistor ^{Note 1} .		
	P1C3/AD5				
	P1C2/AD4				
	P1C1/AMIFC ^{Note 2}		Set to port mode and individually connect to V _{DD} or GND via a resistor ^{Note 1} .		
	P1C0/FMIFC ^{Note 2}				
	P1A3/INT4		Independently connect to GND via a resistor ^{Note 1} .		
	P1A2/INT3				
	P1A1				
	P1A0/TM0G				
	P1B3		N-ch open-drain output	Set to low-level output by software and leave open.	
	P1B2/PWM2 to P1B0/PWM0				
			P0A3/SDA	I/O ^{Note 3}	Set to general-purpose input port mode by software and independently connect to V _{DD} or GND via a resistor ^{Note 1} .
			P0A2/SCL		
P0A1/ $\overline{\text{SCK0}}$					
P0A0/SO0					
P0B3/SI0					
P0B2/ $\overline{\text{SCK1}}$					
P0B1/SO1					
P0B0/SI1					
P0C3 to P0C0					
P1D3					
P1D2					
P1D1/BEEP1					
P1D0/BEEP0					
P2A2					
P2A1/FCG1					
P2A0/FCG0					
P2B3 to P2B0					
P2C3 to P2C0					
P2D3 to P2D0					
P2D2 to P2D0					

- Notes**
1. If a pin is externally pulled up (connected to V_{DD} via a resistor) or pulled down (connected to GND via a resistor) with a high resistance, the pin almost enters a high-impedance state, increasing the current (through-current) consumption of the port. Generally, the resistance of a pull-up or pull-down resistor is several 10 kΩ, although it depends on the application circuit.
 2. Do not set these pins as AMIFC and FMIFC pins; otherwise, the current consumption will increase.
 3. The I/O ports are set in the general-purpose input port mode at power-on reset, when reset by the $\overline{\text{RESET}}$ pin, or when reset by an overflow or underflow of the watchdog timer or the stack.

Table 1-1. Connections of Unused Pins

(2/2)

Pin Name		I/O Mode	Recommended Connection
Port pin	P3A3 to P3A0	I/O ^{Note 2}	Set in general-purpose input port mode by software and independently connect to V _{DD} or GND via a resistor ^{Note 1} .
	P3B3 to P3B0		
	P3C3 to P3C0		
	P3D3 to P3D0		
Non-port pins	CE	Input	Connect to V _{DD} via a resistor ^{Note 1} .
	EO1	Output	Leave open.
	EO0		
	INT0 to INT2	Input	Independently connect to GND via a resistor ^{Note 1} .
	$\overline{\text{RESET}}$	Input	Connect to V _{DD} via a resistor ^{Note 1} .
	TEST	–	Directly connect to GND.
	VCOH	Input	Disable PLL via software and leave open.
VCOL			

- Notes**
1. If a pin is externally pulled up (connected to V_{DD} via a resistor) or pulled down (connected to GND via a resistor) with a high resistance, the pin almost enters a high-impedance state, increasing the current (through-current) consumption of the port. Generally, the resistance of a pull-up or pull-down resistor is several 10 kΩ, although it depends on the application circuit.
 2. The I/O ports are set in the general-purpose input port mode at power-on reset, when reset by the $\overline{\text{RESET}}$ pin, or when reset by an overflow or underflow of the watchdog timer or the stack.

1.5 Cautions on Using CE, INT0 to INT4, and $\overline{\text{RESET}}$ Pins (Only in Normal Operation Mode)

The CE, INT0 to INT4, and $\overline{\text{RESET}}$ pins have a function to set a test mode in which the internal operations of the μPD17P709A are tested (IC test), in addition to the functions listed in **1.1 Pin Function List**.

When a voltage exceeding V_{DD} is applied to any of these pins, the device is set in the test mode. If a noise exceeding V_{DD} is superimposed during normal operation, therefore, the test mode is set by mistake, affecting the normal operation.

Especially if the wiring length of pins is too long, noise is superimposed on these pins. In consequence, the above problem occurs.

Therefore, keep the wiring length as short as possible to prevent noise from being superimposed. If superimposition of noise is unavoidable, connect an external component as illustrated below to suppress the noise.

- **Connect a diode with a low V_F between the pin and V_{DD} .**

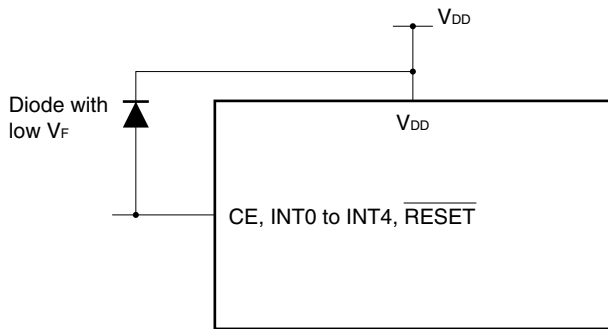

- **Connect a capacitor between the pin and V_{DD} .**

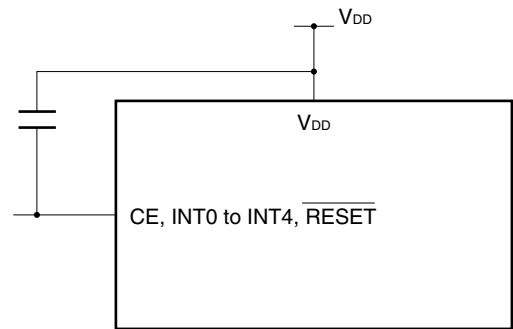

1.6 Cautions on Using TEST Pin (Only in Normal Operation Mode)

When V_{DD} is applied to the TEST pin, the device is set in the test mode or program memory write/verify mode. Therefore, be sure to keep the wiring length of this pin as short as possible, and directly connect it to the GND pin.

If the wiring length between the TEST pin and GND pin is too long, or if external noise is superimposed on the TEST pin, generating a potential difference between the TEST pin and GND pin, your program may not run normally.

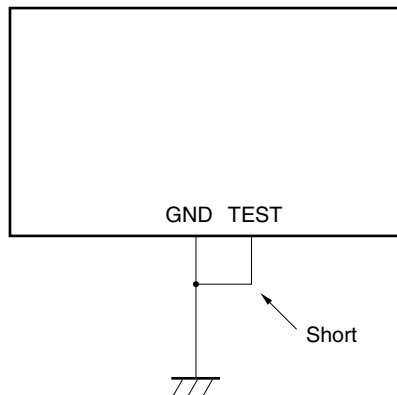

2. ONE-TIME PROM (PROGRAM MEMORY) WRITE, READ, AND VERIFY

The μPD17P709A includes a 16,384 × 16-bit one-time PROM program memory. In normal operation, this PROM is accessed in 16-bit word units. During program memory write, read, and verify, the PROM is accessed in 8-bit word units. The higher 8 bits of a 16-bit word are located at an even-numbered address, and the lower 8 bits are located at an odd-numbered address.

The pins used for the write, read, and verify operations of this one-time PROM are listed in Table 2-1. Clock input from the CLK pin, instead of address input, is used for updating addresses.

Table 2-1. Pins Used for Program Memory Write, Read, and Verify

Pin Name	Function
V _{PP}	Program voltage application (+12.5 V)
CLK	Address update clock input
MD0 to MD3	Operation mode selection
D0 to D7	8-bit data I/O
V _{DD0} , V _{DD1}	Supply voltage application (+6 V)

The specified PROM programmer and a dedicated programmer adapter are used for writing to the on-chip PROM.

The following PROM programmers and programmer adapters are usable.

PROM Programmer	Programmer Adapter
PG-1500 + PA-17KDZ (adapter for PG-1500)	PA17P709GC

Third-party PROM programmers are also available, such as the AF-9703, AF-9704, AF-9705, and AF-9706 (manufactured by Ando Electric Co., Ltd.)

Figure 2-1. PA-17P709GC and PA-17KDZ

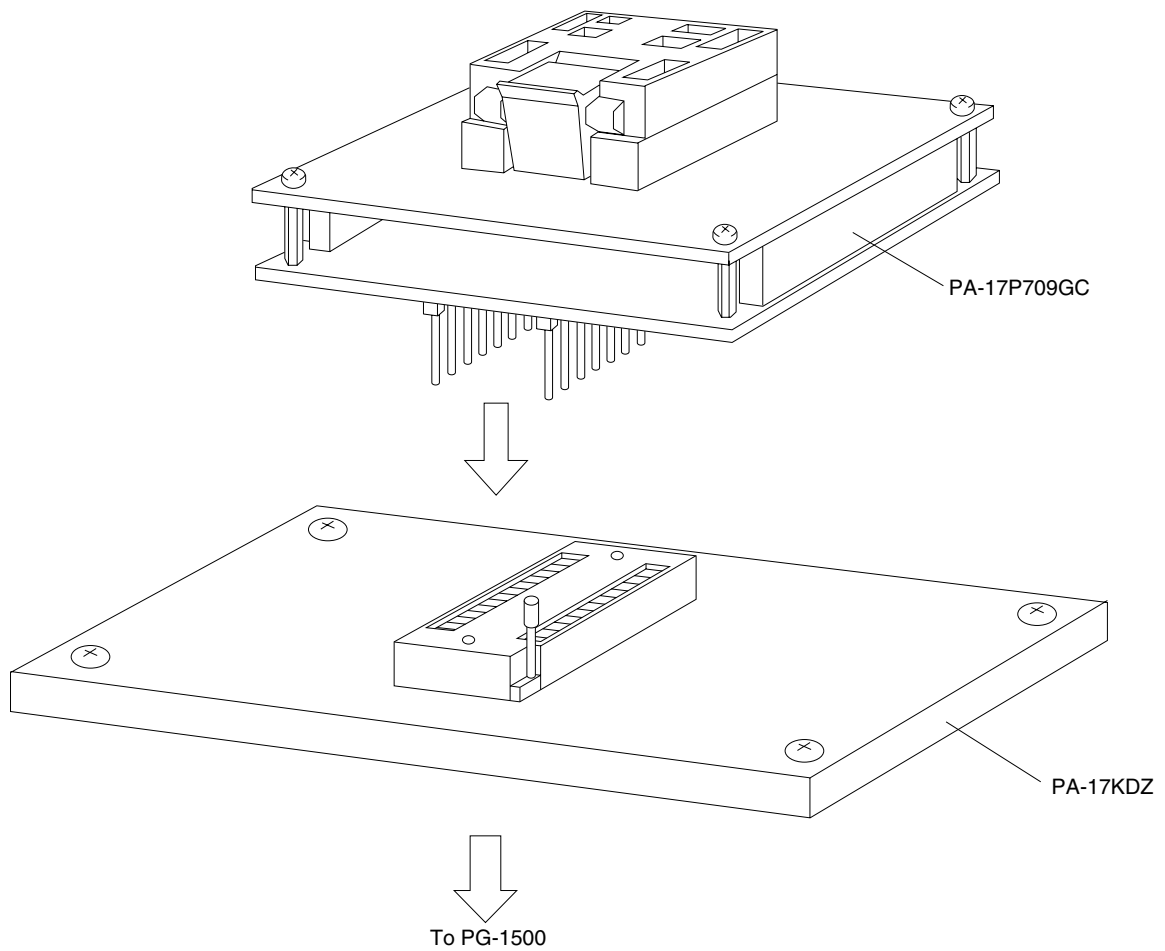

2.1 Operation Modes for Program Memory Write, Read, and Verify

When +6 V is applied to the V_{DD} pin and +12.5 V to the V_{PP} pin, the μPD17P709A enters the program memory write, read, and verify mode.

The following operation modes can be set by setting pins MD0 to MD3 as shown below.

Pins not listed in Table 2-2 should be connected to GND via a pull-down resistor (470 Ω) (refer to **PIN CONFIGURATION (2) PROM programming mode**).

Table 2-2. Operation Mode Setting for Program Memory Write, Read, and Verify

Operation Mode Setting						Operation Mode
V _{PP}	V _{DD}	MD0	MD1	MD2	MD3	
+12.5 V	+6 V	H	L	H	L	Program memory address 0-clear mode
		L	H	H	H	Write mode
		L	L	H	H	Write/verify mode
		H	×	H	H	Program inhibit mode

Remark ×: L or H

2.2 Program Memory Write Procedure

Program memory can be written at high speed using the following procedure.

- (1) Pull down unused pins to GND via a resistor. Set the CLK pin to low.
- (2) Supply 5 V to the V_{DD} pin. Set the V_{PP} pin to low.
- (3) Wait for 10 μs and then supply 5 V to the V_{PP} pin.
- (4) Set the mode setting pin to program memory address 0-clear mode.
- (5) Supply +6 V to the V_{DD} pin and +12.5 V to the V_{PP} pin.
- (6) Set the program inhibit mode.
- (7) Write data in the 1 ms write mode.
- (8) Set the program inhibit mode.
- (9) Set the verify mode. If the data is correct, go to step (10). If not, repeat steps (7) to (9).
- (10) (X: Number of write operations from steps (7) to (9)) × 1 ms additional write.
- (11) Set the program inhibit mode.
- (12) Input four pulses to the CLK pin to increment the program memory address by one.
- (13) Repeat steps (7) to (12) until the end address is reached.
- (14) Set the program memory address 0-clear mode.
- (15) Change the V_{DD} and V_{PP} pins to 5 V.
- (16) Turn off the power.

The following figure shows steps (2) to (12).

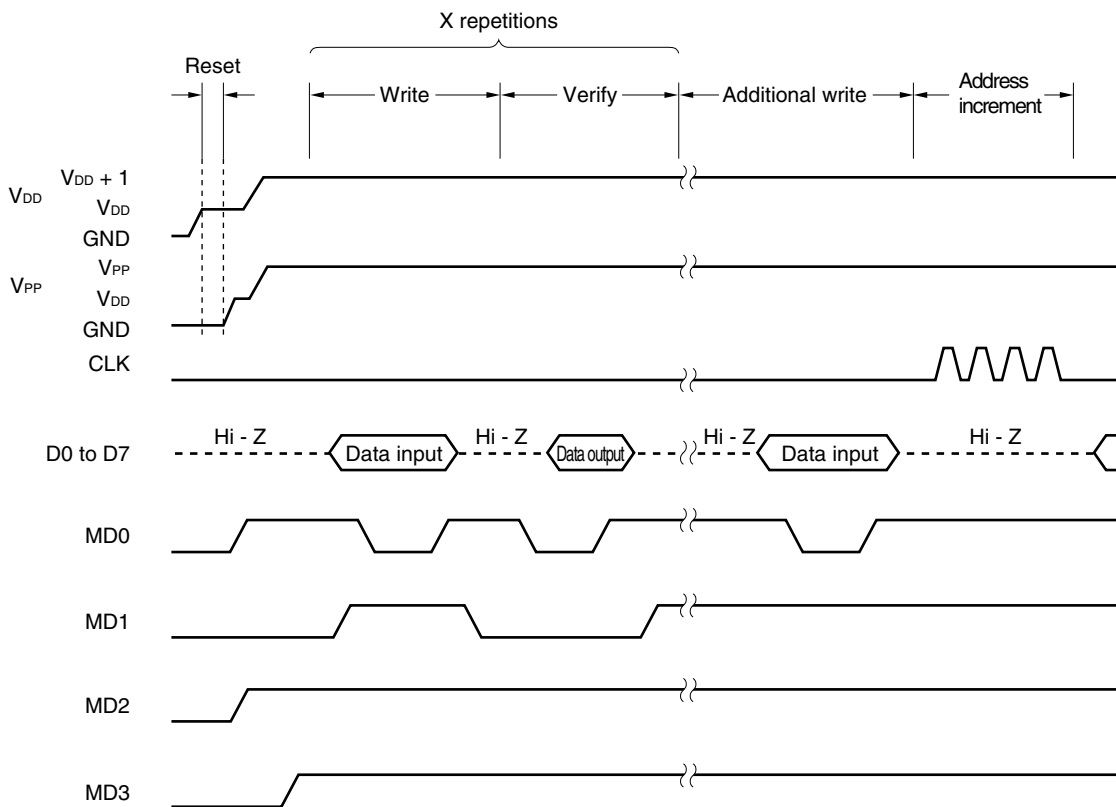

2.3 Program Memory Read Procedure

- (1) Pull down unused pins to GND via a resistor. Set the CLK pin to low.
- (2) Supply 5 V to the V_{DD} pin. Set the V_{PP} pin to low.
- (3) Wait for 10 μs and then supply 5 V to the V_{PP} pin.
- (4) Set the mode setting pin to program memory address 0-clear mode.
- (5) Supply +6 V to the V_{DD} pin and +12.5 V to the V_{PP} pin.
- (6) Set the program inhibit mode.
- (7) Set the verify mode. Addresses are incremented by one for each 4-pulse cycle input to the CLK pin.
- (8) Set the program inhibit mode.
- (9) Set the program memory address 0-clear mode.
- (10) Change the V_{DD} and V_{PP} pins to 5 V.
- (11) Turn off the power.

The following figure shows steps (2) to (9).

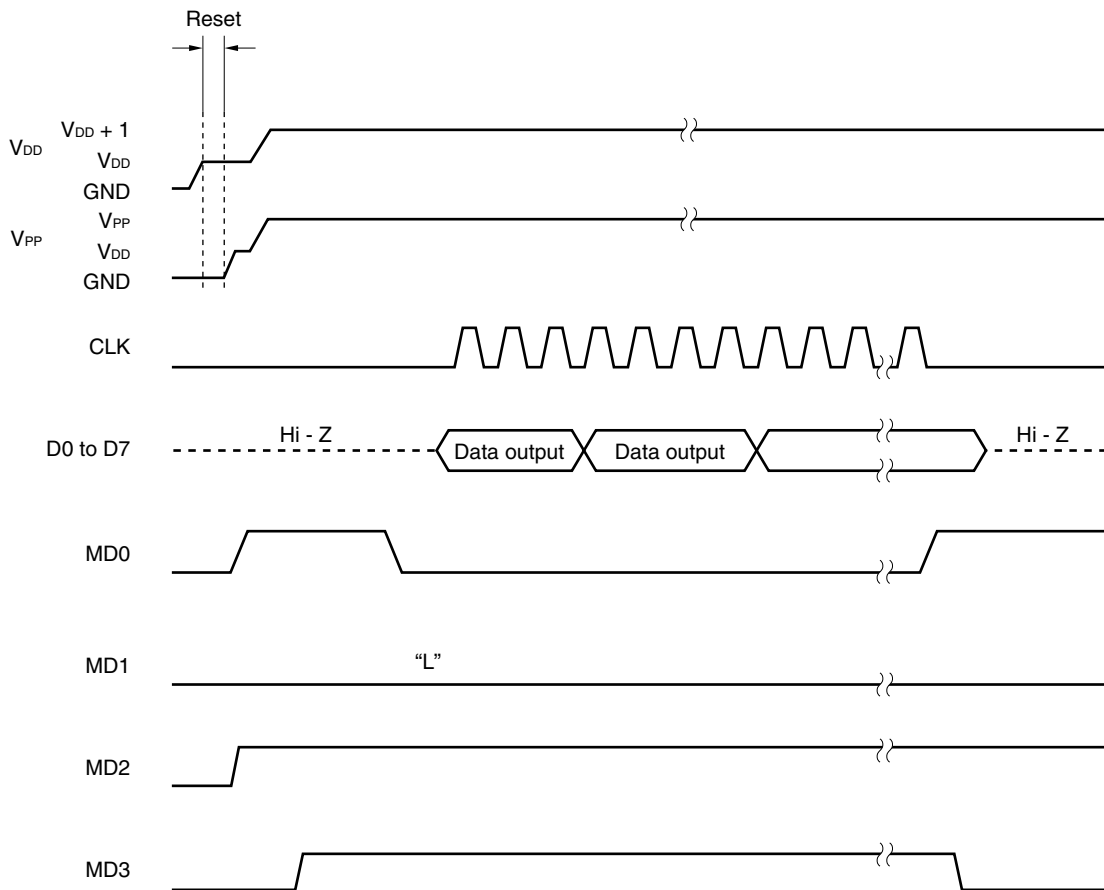

3. ELECTRICAL SPECIFICATIONS

Absolute Maximum Ratings (T_A = 25°C)

Parameter	Symbol	Conditions	Ratings	Unit
Supply voltage	V _{DD}		-0.3 to +6.0	V
PROM program voltage	V _{PP}		-0.3 to +13.5	V
Input voltage	V _I	Other than CE, INT0 to INT4, and $\overline{\text{RESET}}$ pins	-0.3 to V _{DD} + 0.3	V
		CE, INT0 to INT4, and $\overline{\text{RESET}}$ pins	-0.3 to V _{DD} + 0.6	V
Output voltage	V _O	Except P1B0 to P1B3	-0.3 to V _{DD} + 0.3	V
Output current, high	I _{OH}	Per pin	-8.0	mA
		Total of P2A0 to P2A2, P3A0 to P3A3, and P3B0 to P3B3	-15.0	mA
		Total of P0A0 to P0A3, P0B0 to P0B3, P0C0 to P0C3, P1D0 to P1D3, P2B0 to P2B3, P2C0 to P2C3, P2D0 to P2D2, P3C0 to P3C3, and P3D0 to P3D3	-25.0	mA
Output current, low	I _{OL}	Per pin for P1B0 to P1B3	12.0	mA
		Per pin for P1B0 to P1B3	8.0	mA
		Total of P2A0 to P2A2, P3A0 to P3A3, and P3B0 to P3B3	15.0	mA
		Total of P0A0 to P0A3, P0B0 to P0B3, P0C0 to P0C3, P1D0 to P1D3, P2B0 to P2B3, P2C0 to P2C3, P2D0 to P2D2, P3C0 to P3C3, and P3D0 to P3D3	25.0	mA
		Total of P1B0 to P1B3 pins	25.0	mA
Output voltage	V _{BDS}	P1B0 to P1B3	14.0	V
Total power dissipation	P _t		200	mW
Operating ambient temperature	T _A		-40 to +85	°C
Storage temperature	T _{stg}		-55 to +125	°C

Caution Product quality may suffer if the absolute maximum rating is exceeded even momentarily for any parameter. That is, the absolute maximum ratings are rated values at which the product is on the verge of suffering physical damage, and therefore the product must be used under conditions that ensure that the absolute maximum ratings are not exceeded.

Recommended Operating Range (T_A = -40 to +85°C)

Parameter	Symbol	Conditions	MIN.	TYP.	MAX.	Unit
Supply voltage	V _{DD1}	When CPU and PLL are operating	4.5	5.0	5.5	V
	V _{DD2}	When CPU and PLL are stopped	3.5	5.0	5.5	V

Recommended Output Withstanding Voltage (T_A = -40 to +85°C)

Parameter	Symbol	Conditions	MIN.	TYP.	MAX.	Unit
Output withstanding voltage	V _{BDS}	P1B0 to P1B3			12	V

DC Characteristics (T_A = -40 to +85°C, V_{DD} = 3.5 to 5.5 V)

Parameter	Symbol	Conditions	MIN.	TYP.	MAX.	Unit
Supply current	I _{DD1}	When CPU is operating and PLL is stopped with sine wave input to X _{IN} pin. (f _{IN} = 4.5 MHz ±1%, V _{IN} = V _{DD})		1.5	3.0	mA
	I _{DD2}	When CPU and PLL are stopped with sine-wave input to X _{IN} pin. (f _{IN} = 4.5 MHz ±1%, V _{IN} = V _{DD}) With HALT instruction		0.7	1.5	mA
Data retention voltage	V _{DDR1}	Crystal oscillation	3.5		5.5	V
	V _{DDR2}	Crystal oscillation	Power failure detection by timer FF	2.2	5.5	V
	V _{DDR3}	stopped	Data memory retained	2.0	5.5	V
Data retention current	I _{DDR1}	Crystal oscillation	V _{DD} = 5 V, T _A = 25°C	2.0	4.0	μA
	I _{DDR2}	stopped		2.0	30.0	μA
Input voltage, high	V _{IH1}	P0A0, P0B1, P0C0 to P0C3, P1A0, P1A1, P1C0 to P1C3, P1D0 to P1D3, P2A2, P2B0 to P2B3, P2C0 to P2C3, P2D0 to P2D2, P3A0 to P3A3, P3B0 to P3B3, P3C0 to P3C3, P3D0 to P3D3	0.7V _{DD}		V _{DD}	V
	V _{IH2}	P0A1 to P0A3, P0B0, P0B2, P0B3, P2A0, P2A1, CE, INT0 to INT4, RESET _̄	0.8V _{DD}		V _{DD}	V
	V _{IH3}	P0D0 to P0D3	0.55V _{DD}		V _{DD}	V
Input voltage, low	V _{IL1}	P0A0, P0B1, P0C0 to P0C3, P1A0, P1A1, P1C0 to P1C3, P1D0 to P1D3, P2A2, P2B0 to P2B3, P2C0 to P2C3, P2D0 to P2D2, P3A0 to P3A3, P3B0 to P3B3, P3C0 to P3C3, P3D0 to P3D3	0		0.3V _{DD}	V
	V _{IL2}	P0A1 to P0A3, P0B0, P0B2, P0B3, P2A0, P2A1, CE, INT0 to INT4, RESET _̄	0		0.2V _{DD}	V
	V _{IL3}	P0D0 to P0D3	0		0.15V _{DD}	V
Output current, high	I _{OH1}	P0A0 to P0A3, P0B0 to P0B3, P0C0 to P0C3, P1D0 to P1D3, P2A0 to P2A2, P2B0 to P2B3, P2C0 to P2C3, P2D0 to P2D2, P3A0 to P3A3, P3B0 to P3B3, P3C0 to P3C3, P3D0 to P3D3 V _{OH} = V _{DD} - 1 V	-1.0			mA
	I _{OH2}	EO0, EO1	V _{DD} = 4.5 to 5.5 V, V _{OH} = V _{DD} - 1 V	-3.0		mA
Output current, low	I _{OL1}	P0A0 to P0A3, P0B0 to P0B3, P0C0 to P0C3, P1D0 to P1D3, P2A0 to P2A2, P2B0 to P2B3, P2C0 to P2C3, P2D0 to P2D2, P3A0 to P3A3, P3B0 to P3B3, P3C0 to P3C3, P3D0 to P3D3 V _{OL} = 1 V	1.0			mA
	I _{OL2}	EO0, EO1	V _{DD} = 4.5 to 5.5 V, V _{OL} = 1 V	3.0		mA
	I _{OL3}	P1B0 to P1B3	V _{OL} = 1 V	7.0		mA
Input current, high	I _{IH}	P0D0 to P0D3 pulled down	V _{IN} = V _{DD}	5.0	150	μA
Output off leakage current	I _{LO1}	P1B0 to P1B3	V _{IN} = 12 V		1.0	μA
	I _{LO2}	EO0, EO1	V _{IN} = V _{DD} , V _{IN} = 0 V		±1.0	μA
Input leakage current, high	I _{LIH}	Input pin	V _{IN} = V _{DD}		1.0	μA
Input leakage current, low	I _{LIL}	Input pin	V _{IN} = 0 V		-1.0	μA

AC Characteristics (T_A = -40 to +85°C, V_{DD} = 5 V ±10%)

Parameter	Symbol	Conditions	MIN.	TYP.	MAX.	Unit	
Operating frequency	f _{IN1}	VCOL pin, MF mode	Sine-wave input V _{IN} = 0.15V _{p-p}	0.8		3	MHz
			Sine-wave input V _{IN} = 0.1V _{p-p}	0.5		3	MHz
	f _{IN2}	VCOL pin, HF mode, sine-wave input V _{IN} = 0.1V _{p-p} Note	10		40	MHz	
	f _{IN3}	VCOH pin, VHF mode, sine-wave input V _{IN} = 0.1V _{p-p} Note	60		130	MHz	
	f _{IN4}	AMIFC pin, sine-wave input V _{IN} = 0.15V _{p-p}	0.4		0.5	MHz	
	f _{IN5}	FMIFC pin, FMIF count mode, sine-wave input V _{IN} = 0.20V _{p-p}	10		11	MHz	
	f _{IN6}	FMIFC pin, AMIF count mode, sine-wave input V _{IN} = 0.15V _{p-p}	0.4		0.5	MHz	
SIO0 input frequency	f _{IN7}	External clock			1	MHz	
SIO1 input frequency	f _{IN8}	External clock			0.7	MHz	

Note The condition of sine-wave input V_{IN} = 0.1V_{p-p} is the rated value when the μPD17P709A is operating alone. Where influence of noise must be taken into consideration, operation under input amplitude conditions of V_{IN} = 0.15V_{p-p} is recommended.

A/D Converter Characteristics (T_A = -40 to +85°C, V_{DD} = 5 V ±10%)

Parameter	Symbol	Conditions	MIN.	TYP.	MAX.	Unit
A/D conversion total error		8 bits			±3.0	LSB
A/D conversion total error		8 bits T _A = 0 to 85°C			±2.5	LSB

Reference Characteristics (T_A = +25°C, V_{DD} = 5.0 V)

Parameter	Symbol	Conditions	MIN.	TYP.	MAX.	Unit
Supply current	I _{DD3}	When CPU and PLL are operating with sine-wave input to VCOH pin (f _{IN} = 130 MHz, V _{IN} = 0.3V _{p-p})		6.0	12.0	mA

DC Programming Characteristics (T_A = 25°C, V_{DD} = 6.0 ±0.25 V, V_{PP} = 12.5 ±0.5 V)

Parameter	Symbol	Conditions	MIN.	TYP.	MAX.	Unit
Input voltage, high	V _{IH1}	Pins other than CLK	0.7V _{DD}		V _{DD}	V
	V _{IH2}	CLK	V _{DD} - 0.5		V _{DD}	V
Input voltage, low	V _{IL1}	Pins other than CLK	0		0.2V _{DD}	V
	V _{IL2}	CLK	0		0.4	V
Input leakage current	I _{LI}	V _{IN} = V _{IL} or V _{IH}			10	μA
Output voltage, high	V _{OH}	I _{OH} = -1 mA	V _{DD} - 1.0			V
Output voltage, low	V _{OL}	I _{OL} = 1 mA			1.0	V
V _{DD} supply current	I _{DD}				30	mA
V _{PP} supply current	I _{PP}	MD0 = V _{IL} , MD1 = V _{IH}			30	mA

- Cautions 1. Ensure that V_{PP} does not exceed +13.5 V including overshoot.**
- 2. V_{DD} must be applied before V_{PP}, and cut after V_{PP}.**

AC Programming Characteristics ($T_A = 25^\circ\text{C}$, $V_{DD} = 6.0 \pm 0.25\text{ V}$, $V_{PP} = 12.5 \pm 0.5\text{ V}$)

Parameter	Symbol	Conditions	MIN.	TYP.	MAX.	Unit
Address setup time ^{Note} (to MD0↓)	t_{AS}		2			μs
MD1 setup time (to MD0↓)	t_{M1S}		2			μs
Data setup time (to MD0↓)	t_{DS}		2			μs
Address hold time ^{Note} (from MD0↑)	t_{AH}		2			μs
Data hold time (from MD0↑)	t_{DH}		2			μs
Delay time from MD0↑ to data output float	t_{DF}		0		130	ns
V_{PP} setup time (to MD3↑)	t_{VPS}		2			μs
V_{DD} setup time (to MD3↑)	t_{VDS}		2			μs
Initial program pulse width	t_{PW}		0.95	1.0	1.05	ms
Additional program pulse width	t_{OPW}		0.95		21.0	ms
MD0 setup time (to MD1↑)	t_{M0S}		2			μs
Delay time from MD0↓ to data output	t_{DV}	MD0 = MD1 = V_{IL}			1	μs
MD1 hold time (from MD0↑)	t_{M1H}	$t_{M1H} + t_{M1R} \geq 50\ \mu\text{s}$	2			μs
MD1 recovery time (from MD0↓)	t_{M1R}		2			μs
Program counter reset time	t_{PCR}		10			μs
CLK input high-/low-level widths	t_{XH}, t_{XL}		0.125			μs
CLK input frequency	f_X				4.19	MHz
Initial mode setting time	t_i		2			μs
MD3 setup time (to MD1↑)	t_{M3S}		2			μs
MD3 hold time (from MD1↓)	t_{M3H}		2			μs
MD3 setup time (to MD0↓)	t_{M3SR}	Program memory read	2			μs
Delay time from address ^{Note} to data output	t_{DAD}	Program memory read			2	μs
Hold time from address ^{Note} to data output	t_{HAD}	Program memory read	0		130	ns
MD3 hold time (from MD0↑)	t_{M3HR}	Program memory read	2			μs
Delay time from MD3↓ to data output float	t_{DFR}	Program memory read			2	μs
Reset setup time	t_{RES}		10			μs

Note The internal address signal is incremented by 1 on the 3rd fall of a four-clock input (CLK) cycle, and is not connected to a pin.

Program Memory Write Timing

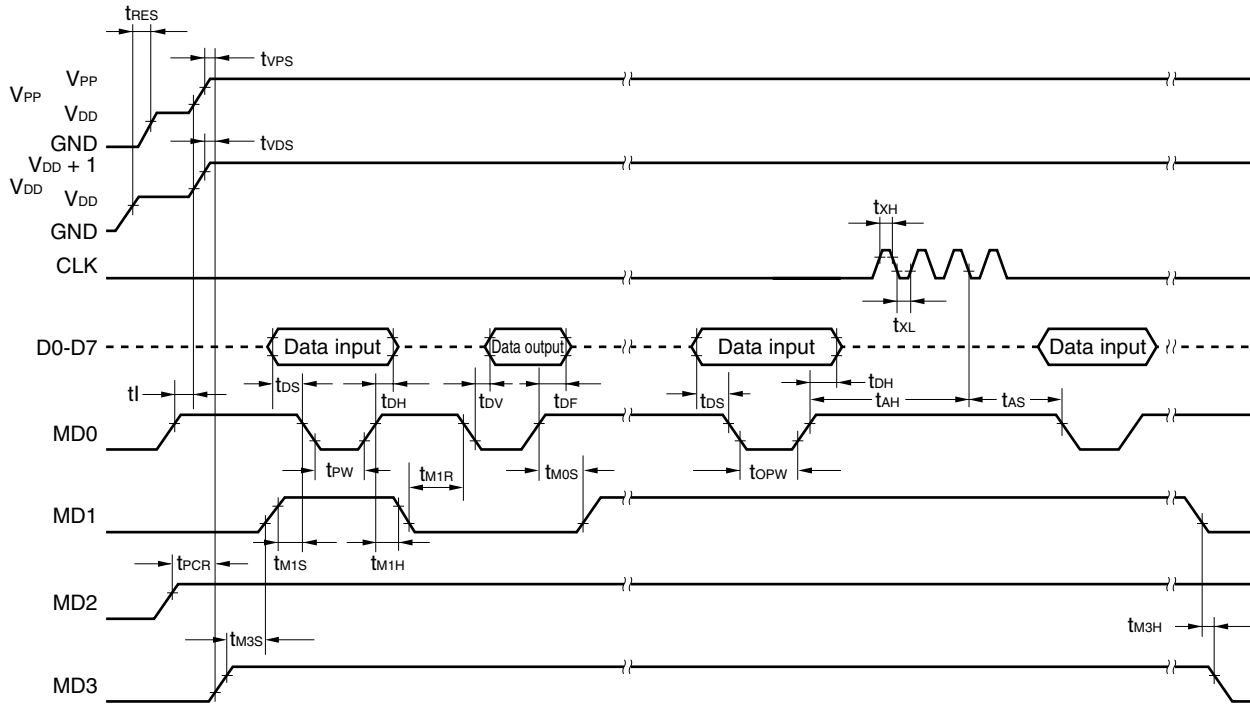

Remark The dashed line indicates high-impedance.

Program Memory Read Timing

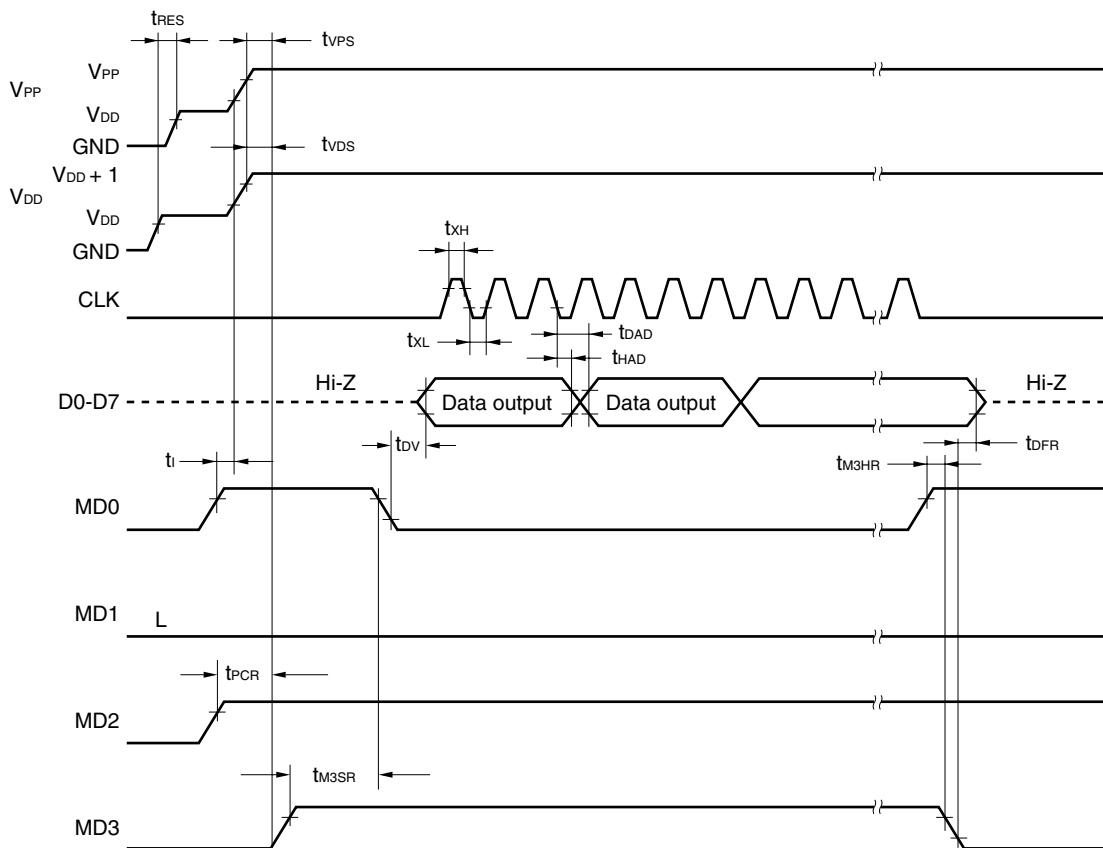

4. PACKAGE DRAWING

80-PIN PLASTIC QFP (14x14)

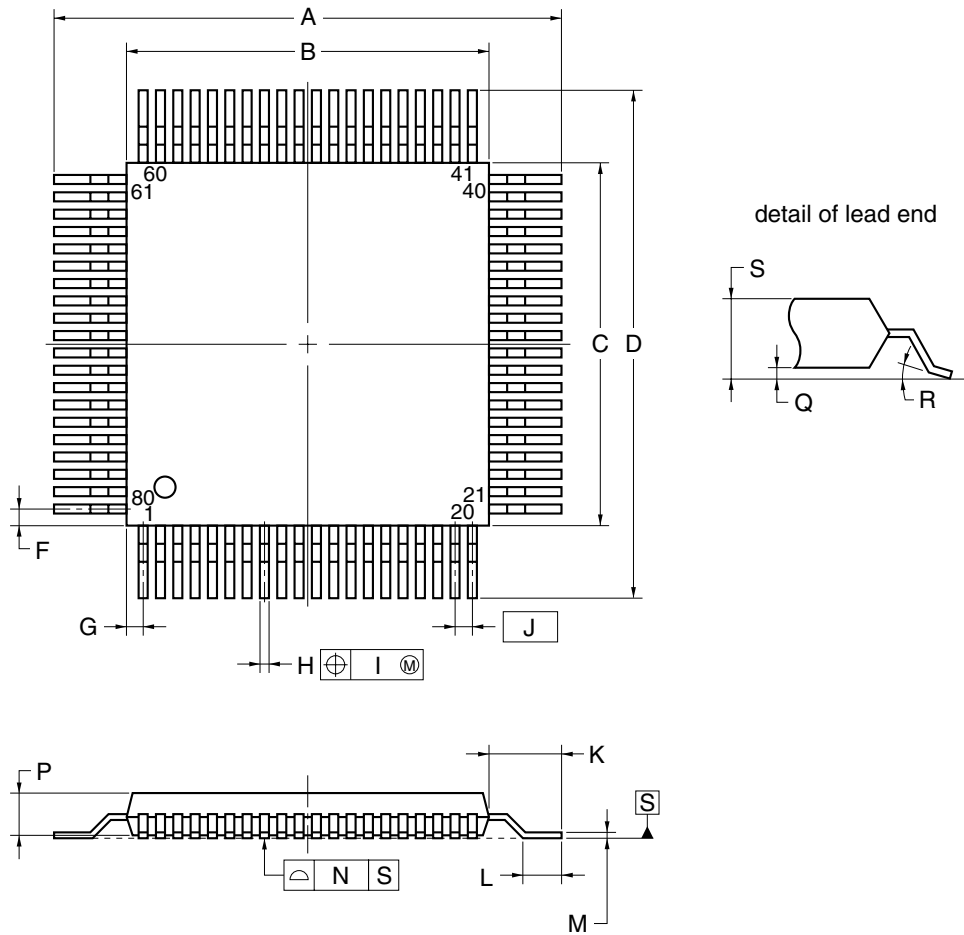

NOTE

Each lead centerline is located within 0.13 mm of its true position (T.P.) at maximum material condition.

ITEM	MILLIMETERS
A	17.2±0.4
B	14.0±0.2
C	14.0±0.2
D	17.2±0.4
F	0.825
G	0.825
H	0.30±0.10
I	0.13
J	0.65 (T.P.)
K	1.6±0.2
L	0.8±0.2
M	0.15 ^{+0.10} _{-0.05}
N	0.10
P	2.7±0.1
Q	0.1±0.1
R	5°±5°
S	3.0 MAX.

S80GC-65-3B9-6

5. RECOMMENDED SOLDERING CONDITIONS

The μPD17P709A should be soldered and mounted under the following recommended conditions.

For details of the recommended soldering conditions, refer to the document **Semiconductor Device Mounting Technology Manual (C10535E)**.

For soldering methods and conditions other than those recommended below, contact an NEC sales representative.

Table 5-1. Surface Mounting Type Soldering Conditions

μPD17P709AGC-3B9: 80-pin plastic QFP (14 × 14)

Soldering Method	Soldering Conditions	Recommended Condition Symbol
Infrared reflow	Package peak temperature: 235°C, Time: 30 seconds MAX. (at 210°C or higher.), Count: Three times or less	IR35-00-3
VPS	Package peak temperature: 215°C, Time: 40 seconds MAX. (at 200°C or higher.), Count: Three times or less	VP15-00-3
Wave soldering	Solder bath temperature: 260°C MAX., Time: 10 seconds MAX., Count: Once, Preheating temperature: 120°C MAX. (package surface temperature)	WS60-00-1
Partial heating	Pin temperature: 300°C MAX., Time: 3 seconds MAX. (per pin row)	—

Caution Do not use different soldering methods together (except for partial heating).

APPENDIX DEVELOPMENT TOOLS

The following development tools are available for development of programs for the μPD17P709A.

Hardware

Name	Outline
In-circuit emulator (IE-17K-ET ^{Note 1})	IE-17K-ET is an in-circuit emulator that can be used with any model in the 17K Series. IE-17K-ET is connected to a host machine, which is PC-9800 series or IBM PC/AT™, with RS-232C. By using these in-circuit emulators with a system evaluation board (SE board) corresponding to each model, these emulators operate as emulators specific to a model. When man-machine interface software <i>SIMPLEHOST</i> ™ is used, a more sophisticated debugging environment can be created.
SE board (SE-17709)	SE-17709 is an SE board for the μPD17709A Subseries. This board can be used alone to evaluate a system, or in combination with an in-circuit emulator for debugging.
Emulation probe (EP-17K80GC)	EP-17K80GC is an emulation probe for the μPD17P709AGC. By using this probe with EV-9200GC-80 ^{Note 2} , the SE board and target system are connected.
Conversion socket (EV-9200GC-80 ^{Note 2})	EV-9200GC-80 is a conversion socket for 80-pin plastic QFP (14 × 14). It is used to connect the EP-17K80GC and target system.
PROM programmer (PG-1500)	PG-1500 is a PROM programmer supporting μPD17P709A. It can program the μPD17P709A when connected with the PG-1500 adapter PA-17KDZ and programmer adapter PA-17P709GC.
Programmer adapter (PA-17P709GC)	PA-17P709GC is an adapter to program the μPD17P709A. It is used with PG-1500.

- Notes**
1. External power supply type
 2. One EV-9200GC-80 is supplied with the EP-17K80GC. Five EV-9200GC-80 are also available as a set.

Remark Third-party PROM programmers AF-9703, AF-9704, AF-9705, and AF-9706 are available from Ando Electric Co., Ltd. Use these programmers with programmer adapter PA-17P709GC. For details, consult Ando Electric Co., Ltd. (TEL: +8-44-549-7300).

Software

Name	Outline	Host Machine	OS	Media	Parts Number
17K Series assembler (RA17K)	RA17K is an assembler that can be commonly used with 17K Series. To develop programs for the μPD17P709A, this RA17K and a device file (AS17704) are used in combination.	PC-9800 series	Japanese Windows™	3.5" 2HD	μSAA13RA17K
		IBM PC/AT compatibles	Japanese Windows	3.5" 2HC	μSAB13RA17K
			English Windows		μSBB13RA17K
Device file (AS17704)	AS17704 is a device file for the μPD17P709A. It is used with the assembler common to the 17K Series (RA17K).	PC-9800 series	Japanese Windows	3.5" 2HD	μSAA13AS17704
		IBM PC/AT compatibles	Japanese Windows	3.5" 2HC	μSAB13AS17704
			English Windows		μSBB13AS17704
Support software (<i>SIMPLEHOST</i>)	<i>SIMPLEHOST</i> is man-machine interface software that runs on Windows when a program is developed by using an in-circuit emulator and personal computer.	PC-9800 series	Japanese Windows	3.5" 2HD	μSAA13ID17K
		IBM PC/AT compatibles	Japanese Windows	3.5" 2HC	μSAB13ID17K
			English Windows		μSBB13ID17K

NOTES FOR CMOS DEVICES**① PRECAUTION AGAINST ESD FOR SEMICONDUCTORS**

Note:

Strong electric field, when exposed to a MOS device, can cause destruction of the gate oxide and ultimately degrade the device operation. Steps must be taken to stop generation of static electricity as much as possible, and quickly dissipate it once, when it has occurred. Environmental control must be adequate. When it is dry, humidifier should be used. It is recommended to avoid using insulators that easily build static electricity. Semiconductor devices must be stored and transported in an anti-static container, static shielding bag or conductive material. All test and measurement tools including work bench and floor should be grounded. The operator should be grounded using wrist strap. Semiconductor devices must not be touched with bare hands. Similar precautions need to be taken for PW boards with semiconductor devices on it.

② HANDLING OF UNUSED INPUT PINS FOR CMOS

Note:

No connection for CMOS device inputs can be cause of malfunction. If no connection is provided to the input pins, it is possible that an internal input level may be generated due to noise, etc., hence causing malfunction. CMOS devices behave differently than Bipolar or NMOS devices. Input levels of CMOS devices must be fixed high or low by using a pull-up or pull-down circuitry. Each unused pin should be connected to V_{DD} or GND with a resistor, if it is considered to have a possibility of being an output pin. All handling related to the unused pins must be judged device by device and related specifications governing the devices.

③ STATUS BEFORE INITIALIZATION OF MOS DEVICES

Note:

Power-on does not necessarily define initial status of MOS device. Production process of MOS does not define the initial operation status of the device. Immediately after the power source is turned ON, the devices with reset function have not yet been initialized. Hence, power-on does not guarantee out-pin levels, I/O settings or contents of registers. Device is not initialized until the reset signal is received. Reset operation must be executed immediately after power-on for devices having reset function.

Regional Information

Some information contained in this document may vary from country to country. Before using any NEC product in your application, please contact the NEC office in your country to obtain a list of authorized representatives and distributors. They will verify:

- Device availability
- Ordering information
- Product release schedule
- Availability of related technical literature
- Development environment specifications (for example, specifications for third-party tools and components, host computers, power plugs, AC supply voltages, and so forth)
- Network requirements

In addition, trademarks, registered trademarks, export restrictions, and other legal issues may also vary from country to country.

NEC Electronics Inc. (U.S.)

Santa Clara, California
Tel: 408-588-6000
800-366-9782
Fax: 408-588-6130
800-729-9288

NEC Electronics (Germany) GmbH

Duesseldorf, Germany
Tel: 0211-65 03 02
Fax: 0211-65 03 490

NEC Electronics (UK) Ltd.

Milton Keynes, UK
Tel: 01908-691-133
Fax: 01908-670-290

NEC Electronics Italiana s.r.l.

Milano, Italy
Tel: 02-66 75 41
Fax: 02-66 75 42 99

NEC Electronics (Germany) GmbH

Benelux Office
Eindhoven, The Netherlands
Tel: 040-2445845
Fax: 040-2444580

NEC Electronics (France) S.A.

Velizy-Villacoublay, France
Tel: 01-3067-5800
Fax: 01-3067-5899

NEC Electronics (France) S.A.

Madrid Office
Madrid, Spain
Tel: 091-504-2787
Fax: 091-504-2860

NEC Electronics (Germany) GmbH

Scandinavia Office
Taeby, Sweden
Tel: 08-63 80 820
Fax: 08-63 80 388

NEC Electronics Hong Kong Ltd.

Hong Kong
Tel: 2886-9318
Fax: 2886-9022/9044

NEC Electronics Hong Kong Ltd.

Seoul Branch
Seoul, Korea
Tel: 02-528-0303
Fax: 02-528-4411

NEC Electronics Singapore Pte. Ltd.

Novena Square, Singapore
Tel: 253-8311
Fax: 250-3583

NEC Electronics Taiwan Ltd.

Taipei, Taiwan
Tel: 02-2719-2377
Fax: 02-2719-5951

NEC do Brasil S.A.

Electron Devices Division
Guarulhos-SP, Brasil
Tel: 11-6462-6810
Fax: 11-6462-6829

Purchase of NEC I²C components conveys a license under the Philips I²C Patent Rights to use these components in an I²C system, provided that the system conforms to the I²C Standard Specification as defined by Philips.

SIMPLEHOST is a trademark of NEC Corporation.

Windows is either a registered trademark or trademark of Microsoft Corporation in the United States and/or other countries.

PC/AT is a trademark of International Business Machines Corporation.

The export of this product from Japan is regulated by the Japanese government. To export this product may be prohibited without governmental license, the need for which must be judged by the customer. The export or re-export of this product from a country other than Japan may also be prohibited without a license from that country. Please call an NEC sales representative.

• The information in this document is current as of September, 2001. The information is subject to change without notice. For actual design-in, refer to the latest publications of NEC's data sheets or data books, etc., for the most up-to-date specifications of NEC semiconductor products. Not all products and/or types are available in every country. Please check with an NEC sales representative for availability and additional information.

- No part of this document may be copied or reproduced in any form or by any means without prior written consent of NEC. NEC assumes no responsibility for any errors that may appear in this document.
- NEC does not assume any liability for infringement of patents, copyrights or other intellectual property rights of third parties by or arising from the use of NEC semiconductor products listed in this document or any other liability arising from the use of such products. No license, express, implied or otherwise, is granted under any patents, copyrights or other intellectual property rights of NEC or others.
- Descriptions of circuits, software and other related information in this document are provided for illustrative purposes in semiconductor product operation and application examples. The incorporation of these circuits, software and information in the design of customer's equipment shall be done under the full responsibility of customer. NEC assumes no responsibility for any losses incurred by customers or third parties arising from the use of these circuits, software and information.
- While NEC endeavours to enhance the quality, reliability and safety of NEC semiconductor products, customers agree and acknowledge that the possibility of defects thereof cannot be eliminated entirely. To minimize risks of damage to property or injury (including death) to persons arising from defects in NEC semiconductor products, customers must incorporate sufficient safety measures in their design, such as redundancy, fire-containment, and anti-failure features.
- NEC semiconductor products are classified into the following three quality grades:
 "Standard", "Special" and "Specific". The "Specific" quality grade applies only to semiconductor products developed based on a customer-designated "quality assurance program" for a specific application. The recommended applications of a semiconductor product depend on its quality grade, as indicated below. Customers must check the quality grade of each semiconductor product before using it in a particular application.

"Standard": Computers, office equipment, communications equipment, test and measurement equipment, audio and visual equipment, home electronic appliances, machine tools, personal electronic equipment and industrial robots

"Special": Transportation equipment (automobiles, trains, ships, etc.), traffic control systems, anti-disaster systems, anti-crime systems, safety equipment and medical equipment (not specifically designed for life support)

"Specific": Aircraft, aerospace equipment, submersible repeaters, nuclear reactor control systems, life support systems and medical equipment for life support, etc.

The quality grade of NEC semiconductor products is "Standard" unless otherwise expressly specified in NEC's data sheets or data books, etc. If customers wish to use NEC semiconductor products in applications not intended by NEC, they must contact an NEC sales representative in advance to determine NEC's willingness to support a given application.

(Note)

(1) "NEC" as used in this statement means NEC Corporation and also includes its majority-owned subsidiaries.

(2) "NEC semiconductor products" means any semiconductor product developed or manufactured by or for NEC (as defined above).