

To our customers,

Old Company Name in Catalogs and Other Documents

On April 1st, 2010, NEC Electronics Corporation merged with Renesas Technology Corporation, and Renesas Electronics Corporation took over all the business of both companies. Therefore, although the old company name remains in this document, it is a valid Renesas Electronics document. We appreciate your understanding.

Renesas Electronics website: <http://www.renesas.com>

April 1st, 2010
Renesas Electronics Corporation

Issued by: Renesas Electronics Corporation (<http://www.renesas.com>)

Send any inquiries to <http://www.renesas.com/inquiry>.

Notice

1. All information included in this document is current as of the date this document is issued. Such information, however, is subject to change without any prior notice. Before purchasing or using any Renesas Electronics products listed herein, please confirm the latest product information with a Renesas Electronics sales office. Also, please pay regular and careful attention to additional and different information to be disclosed by Renesas Electronics such as that disclosed through our website.
2. Renesas Electronics does not assume any liability for infringement of patents, copyrights, or other intellectual property rights of third parties by or arising from the use of Renesas Electronics products or technical information described in this document. No license, express, implied or otherwise, is granted hereby under any patents, copyrights or other intellectual property rights of Renesas Electronics or others.
3. You should not alter, modify, copy, or otherwise misappropriate any Renesas Electronics product, whether in whole or in part.
4. Descriptions of circuits, software and other related information in this document are provided only to illustrate the operation of semiconductor products and application examples. You are fully responsible for the incorporation of these circuits, software, and information in the design of your equipment. Renesas Electronics assumes no responsibility for any losses incurred by you or third parties arising from the use of these circuits, software, or information.
5. When exporting the products or technology described in this document, you should comply with the applicable export control laws and regulations and follow the procedures required by such laws and regulations. You should not use Renesas Electronics products or the technology described in this document for any purpose relating to military applications or use by the military, including but not limited to the development of weapons of mass destruction. Renesas Electronics products and technology may not be used for or incorporated into any products or systems whose manufacture, use, or sale is prohibited under any applicable domestic or foreign laws or regulations.
6. Renesas Electronics has used reasonable care in preparing the information included in this document, but Renesas Electronics does not warrant that such information is error free. Renesas Electronics assumes no liability whatsoever for any damages incurred by you resulting from errors in or omissions from the information included herein.
7. Renesas Electronics products are classified according to the following three quality grades: “Standard”, “High Quality”, and “Specific”. The recommended applications for each Renesas Electronics product depends on the product’s quality grade, as indicated below. You must check the quality grade of each Renesas Electronics product before using it in a particular application. You may not use any Renesas Electronics product for any application categorized as “Specific” without the prior written consent of Renesas Electronics. Further, you may not use any Renesas Electronics product for any application for which it is not intended without the prior written consent of Renesas Electronics. Renesas Electronics shall not be in any way liable for any damages or losses incurred by you or third parties arising from the use of any Renesas Electronics product for an application categorized as “Specific” or for which the product is not intended where you have failed to obtain the prior written consent of Renesas Electronics. The quality grade of each Renesas Electronics product is “Standard” unless otherwise expressly specified in a Renesas Electronics data sheets or data books, etc.
 - “Standard”: Computers; office equipment; communications equipment; test and measurement equipment; audio and visual equipment; home electronic appliances; machine tools; personal electronic equipment; and industrial robots.
 - “High Quality”: Transportation equipment (automobiles, trains, ships, etc.); traffic control systems; anti-disaster systems; anti-crime systems; safety equipment; and medical equipment not specifically designed for life support.
 - “Specific”: Aircraft; aerospace equipment; submersible repeaters; nuclear reactor control systems; medical equipment or systems for life support (e.g. artificial life support devices or systems), surgical implantations, or healthcare intervention (e.g. excision, etc.), and any other applications or purposes that pose a direct threat to human life.
8. You should use the Renesas Electronics products described in this document within the range specified by Renesas Electronics, especially with respect to the maximum rating, operating supply voltage range, movement power voltage range, heat radiation characteristics, installation and other product characteristics. Renesas Electronics shall have no liability for malfunctions or damages arising out of the use of Renesas Electronics products beyond such specified ranges.
9. Although Renesas Electronics endeavors to improve the quality and reliability of its products, semiconductor products have specific characteristics such as the occurrence of failure at a certain rate and malfunctions under certain use conditions. Further, Renesas Electronics products are not subject to radiation resistance design. Please be sure to implement safety measures to guard them against the possibility of physical injury, and injury or damage caused by fire in the event of the failure of a Renesas Electronics product, such as safety design for hardware and software including but not limited to redundancy, fire control and malfunction prevention, appropriate treatment for aging degradation or any other appropriate measures. Because the evaluation of microcomputer software alone is very difficult, please evaluate the safety of the final products or system manufactured by you.
10. Please contact a Renesas Electronics sales office for details as to environmental matters such as the environmental compatibility of each Renesas Electronics product. Please use Renesas Electronics products in compliance with all applicable laws and regulations that regulate the inclusion or use of controlled substances, including without limitation, the EU RoHS Directive. Renesas Electronics assumes no liability for damages or losses occurring as a result of your noncompliance with applicable laws and regulations.
11. This document may not be reproduced or duplicated, in any form, in whole or in part, without prior written consent of Renesas Electronics.
12. Please contact a Renesas Electronics sales office if you have any questions regarding the information contained in this document or Renesas Electronics products, or if you have any other inquiries.

(Note 1) “Renesas Electronics” as used in this document means Renesas Electronics Corporation and also includes its majority-owned subsidiaries.

(Note 2) “Renesas Electronics product(s)” means any product developed or manufactured by or for Renesas Electronics.

8-BIT SINGLE-CHIP MICROCONTROLLER

DESCRIPTION

The μ PD78074B and 78075B, which are members of the μ PD78075B Subseries of the 78K/0 Series, are ideal for AV products.

Compared to the existing μ PD78074 and 78075, EMI (Electro Magnetic Interference) noise generated inside the microcontroller is reduced.

Besides a high-speed, high-performance CPU, these microcontrollers have on-chip ROM, RAM, I/O ports, 8-bit resolution A/D converter, 8-bit resolution D/A converter, timer, serial interface, real-time output port, interrupt control, and various other peripheral hardware.

The μ PD78P078 including a one-time PROM version or an EPROM version can operate in the same power supply voltage range as a mask ROM version, and various development tools are available.

The details of the functions are described in the following user's manuals. Be sure to read the documents before starting design.

μ PD78075B, 78075BY Subseries User's Manual : Planned
78K/0 Series User's Manual – Instructions : IEU-1372

FEATURES

- Internal high-capacity ROM and RAM

Item Part Number	Program Memory (ROM)	Data Memory		Package
		Internal High-Speed RAM	Internal Buffer RAM	
μ PD78074B	32 Kbytes	1024 bytes	32 bytes	100-pin plastic QFP (14 × 20 mm, resin thickness 2.7 mm)
μ PD78075B	40 Kbytes			100-pin plastic QFP (14 × 14 mm, resin thickness 1.45 mm)

- External memory expansion space : 64 Kbytes
- Instruction execution time can be changed from high-speed (0.4 μ s) to ultra-low-speed (122 μ s)
- I/O ports: 88 (N-ch open-drain : 8)
- 8-bit resolution A/D converter : 8 channels
- 8-bit resolution D/A converter : 2 channels
- Serial interface : 3 channels
 - 3-wire serial I/O, SBI or 2-wire serial I/O mode: 1 channel
 - 3-wire serial I/O mode : 1 channel
 - 3-wire serial I/O or UART mode : 1 channel
- Timer : 7 channels
- Supply voltage : $V_{DD} = 1.8$ to 5.5 V

APPLICATIONS

Cellular telephones, cordless telephones, audio equipment, printers, VCRs, etc.

The information in this document is subject to change without notice.

ORDERING INFORMATION

Part Number	Package
μ PD78074BGF-xxx-3BA	100-pin plastic QFP (14 × 20 mm, resin thickness 2.7 mm)
μ PD78074BGC-xxx-7EA	100-pin plastic QFP (fine pitch) (14 × 14 mm, resin thickness 1.45 mm)
μ PD78075BGF-xxx-3BA	100-pin plastic QFP (14 × 20 mm, resin thickness 2.7 mm)
μ PD78075BGC-xxx-7EA	100-pin plastic QFP (fine pitch) (14 × 14 mm, resin thickness 1.45 mm)

Remark xxx indicates ROM code suffix.

78K/0 SERIES DEVELOPMENT

The 78K/0 Series products are developed as shown below. The designations appearing inside the boxes are subseries names.

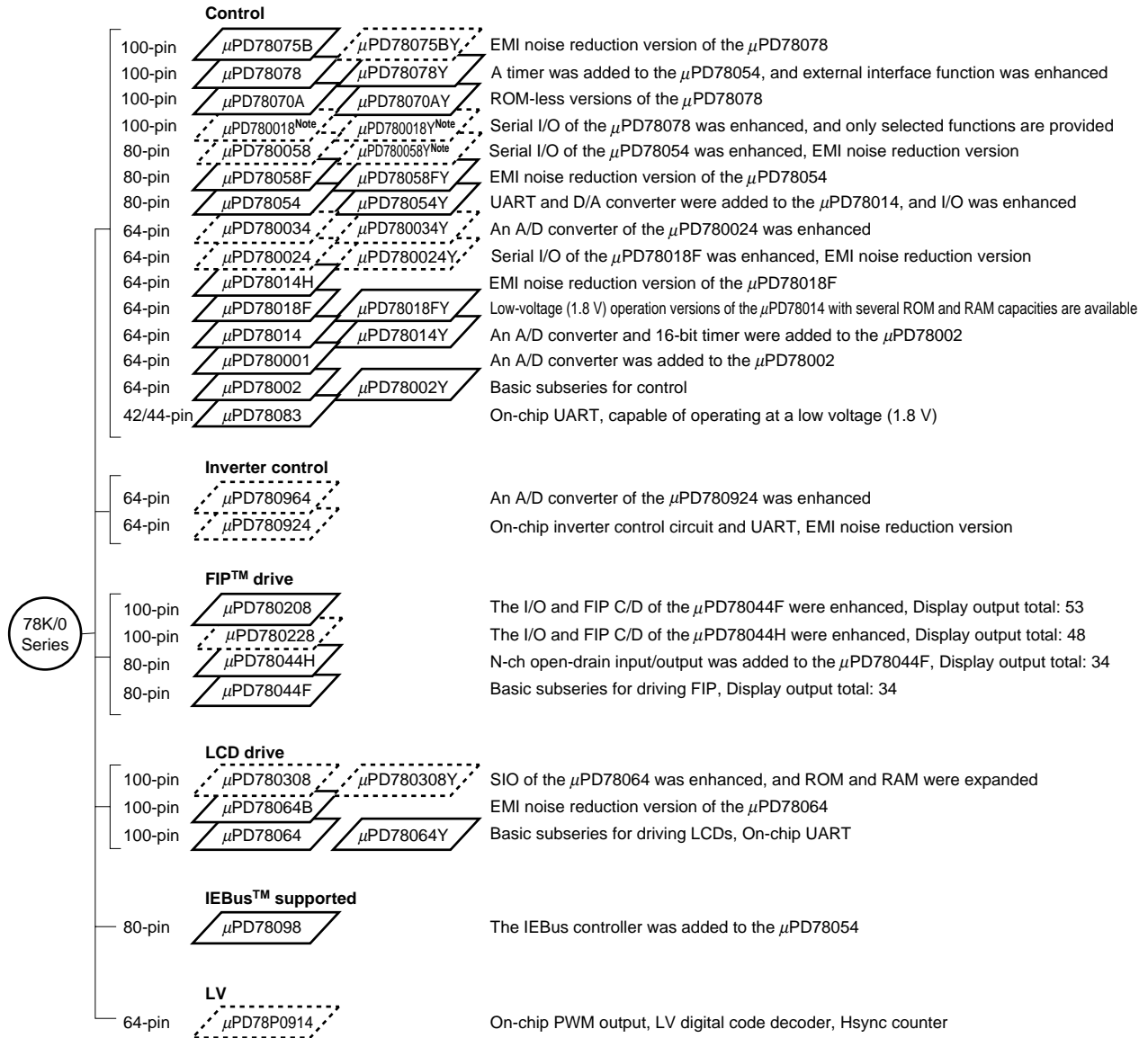
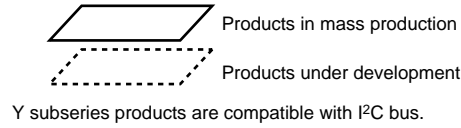

Note Under planning

The major functional differences among the subseries are shown below.

Function Subseries Name		ROM Capacity	Timer				8-bit A/D	10-bit A/D	8-bit D/A	Serial Interface	I/O	V _{DD} MIN. Value	External Expansion																							
			8-bit	16-bit	Watch	WDT																														
Control	μPD78075B	32 K-40 K	4ch	1ch	1ch	1ch	8ch	-	2ch	3ch (UART: 1ch)	88	1.8 V	Available																							
	μPD78078	48 K-60 K								2ch	3ch (time-division 3-wire: 1ch)			68	1.8 V																					
	μPD78070A	-										61				2.7 V																				
	μPD780018	48 K-60 K	88	2.7 V																																
	μPD780058	24 K-60 K			68	1.8 V																														
	μPD78058F	48 K-60 K					69	2.7 V																												
	μPD78054	16 K-60 K							2.0 V																											
	μPD780034	8 K-32 K															51	1.8 V																		
	μPD780024																		53	2.7 V																
	μPD78014H																				39	-														
	μPD78018F	8 K-60 K																					53	Available												
	μPD78014	8 K-32 K																							33	1.8 V										
	μPD780001	8 K																									1ch (UART: 1ch)	-								
	μPD78002	8 K-16 K																											8ch	-						
μPD78083		-											-																							
Inverter control	μPD780964									8 K-32 K	3ch			Note	-																1ch	-	8ch	-	2ch (UART: 2ch)	47
	μPD780924															8ch															-					
FIP drive	μPD780208		32 K-60 K	2ch						1ch	1ch	1ch		8ch	-	-															2ch	74	2.7 V	-		
	μPD780228		48 K-60 K	3ch	-	-									1ch	72															4.5 V					
	μPD78044H		32 K-48 K	2ch	1ch	1ch								68	2.7 V																					
	μPD78044F		16 K-40 K								2ch																									
LCD drive	μPD780308		48 K-60 K	2ch	1ch	1ch	1ch	8ch	-	-	3ch (time-division UART: 1ch)	57		2.0 V	-																					
	μPD78064B		32 K								2ch (UART: 1ch)																									
	μPD78064		16 K-32 K																																	
IEBus supported	μPD78098		32 K-60 K	2ch	1ch	1ch	1ch	8ch	-	2ch	3ch (UART: 1ch)	69		2.7 V	Available																					
LV	μPD78P0914		32 K	6ch	-	-	1ch	8ch	-	-	2ch	54		4.5 V	Available																					

Note 10-bit timer: 1 channel

OVERVIEW OF FUNCTION

Item		Part Number	μPD78074B	μPD78075B
Internal memory	ROM		32 Kbytes	40 Kbytes
	High-speed RAM		1024 bytes	
	Buffer RAM		32 bytes	
	Expansion RAM		None	
Memory space			64 Kbytes	
General registers			8 bits × 32 registers (8 bits × 8 registers × 4 banks)	
Instruction cycle			On-chip instruction execution time selective function	
	When main system clock selected		0.4 μs/0.8 μs/1.6 μs/3.2 μs/6.4 μs/12.8 μs (at 5.0 MHz)	
	When subsystem clock selected		122 μs (at 32.768 kHz)	
Instruction set			<ul style="list-style-type: none"> • 16-bit operation • Multiplication/division (8 bits × 8 bits, 16 bits ÷ 8 bits) • Bit manipulation (set, reset, test, boolean operation) • BCD adjustment, etc. 	
I/O ports			Total : 88 • CMOS input : 2 • CMOS I/O : 78 • N-ch open-drain I/O : 8	
A/D converter			8-bit resolution × 8 channels	
D/A converter			8-bit resolution × 2 channels	
Serial interface			<ul style="list-style-type: none"> • 3-wire serial I/O, SBI, or 2-wire serial I/O mode selectable: 1 channel • 3-wire serial I/O mode (on-chip max. 32-byte automatic transmit/receive function): 1 channel • 3-wire serial I/O or UART mode selectable: 1 channel 	
Timer			<ul style="list-style-type: none"> • 16-bit timer/event counter : 1 channel • 8-bit timer/event counter : 4 channels • Watch timer : 1 channel • Watchdog timer : 1 channel 	
Timer output			5 (14-bit PWM output × 1, 8-bit PWM output × 2)	
Clock output			19.5 kHz, 39.1 kHz, 78.1 kHz, 156 kHz, 313 kHz, 625 kHz, 1.25 MHz, 2.5 MHz, 5.0 MHz (at main system clock of 5.0 MHz) 32.768 kHz (at subsystem clock of 32.768 kHz)	
Buzzer output			1.2 kHz, 2.4 kHz, 4.9 kHz, 9.8 kHz (at main system clock of 5.0 MHz)	
Vectored interrupt source	Maskable		Internal : 15, External : 7	
	Non-maskable		Internal : 1	
	Software		1	
Test input			Internal : 1, External : 1	
Supply voltage			V _{DD} = 1.8 to 5.5 V	
Package			<ul style="list-style-type: none"> • 100-pin plastic QFP (14 × 20 mm, resin thickness 2.7 mm) • 100-pin plastic QFP (fine pitch) (14 × 14 mm, resin thickness 1.45 mm) 	

CONTENTS

1. PIN CONFIGURATION (Top View) 7

2. BLOCK DIAGRAM 10

3. PIN FUNCTIONS 11

 3.1 Port Pins 11

 3.2 Non-port Pins 13

 3.3 Pin I/O Circuits and Recommended Connection of Unused Pins 15

4. MEMORY SPACE 19

5. PERIPHERAL HARDWARE FUNCTIONS 20

 5.1 Ports 20

 5.2 Clock Generator 21

 5.3 Timer/Event Counter 21

 5.4 Clock Output Control Circuit 25

 5.5 Buzzer Output Control Circuit 25

 5.6 A/D Converter 26

 5.7 D/A Converter 26

 5.8 Serial Interfaces 27

 5.9 Real-Time Output Port 29

6. INTERRUPT FUNCTIONS AND TEST FUNCTIONS 30

 6.1 Interrupt Functions 30

 6.2 Test Functions 33

7. EXTERNAL DEVICE EXPANSION FUNCTIONS 34

8. STANDBY FUNCTION 34

9. RESET FUNCTION 35

10. INSTRUCTION SET 36

11. ELECTRICAL SPECIFICATIONS 38

12. CHARACTERISTIC CURVES (FOR REFERENCE ONLY) 65

13. PACKAGE DRAWINGS 67

14. RECOMMENDED SOLDERING CONDITIONS 69

APPENDIX A. DEVELOPMENT TOOLS 70

APPENDIX B. RELATED DOCUMENTS 72

1. PIN CONFIGURATION (Top View)

- 100-pin plastic QFP (14 × 20 mm, resin thickness 2.7 mm)

μPD78074BGF-xxx-3BA, 78075BGF-xxx-3BA

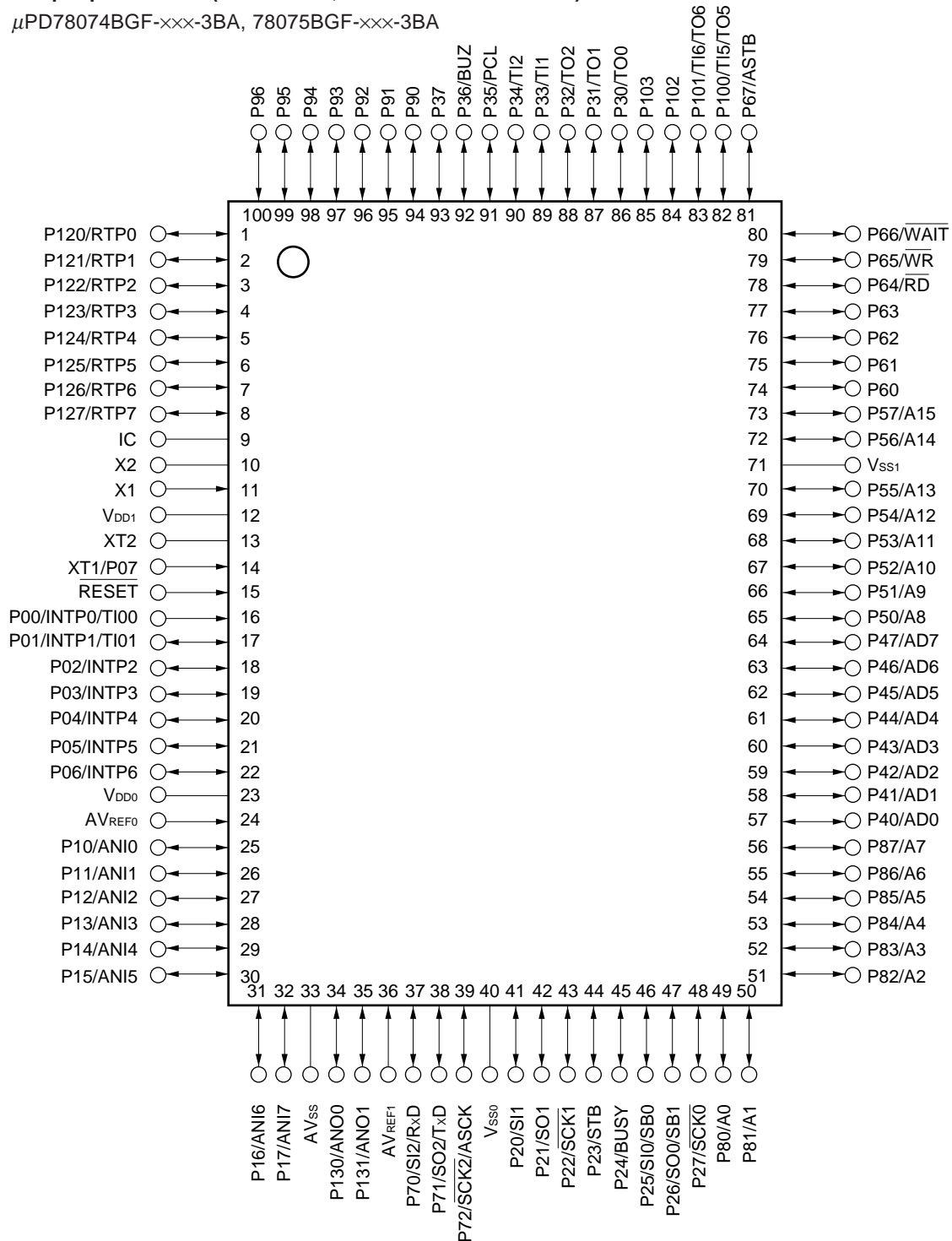

- Cautions**
1. Connect IC (Internally Connected) pin directly to VSS0.
 2. Connect AVSS pin to VSS0.

Remark When the μPD78074B and 78075B are used in applications where the noise generated inside the microcontroller needs to be reduced, the implementation of noise reduction measures, such as supplying voltage to VDD0 and VDD1 individually and connecting VSS0 and VSS1 to different ground lines, is recommended.

- 100-pin plastic QFP (fine pitch) (14 × 14 mm, resin thickness 1.45 mm)

μPD78074BGC-xxx-7EA, 78075BGC-xxx-7EA

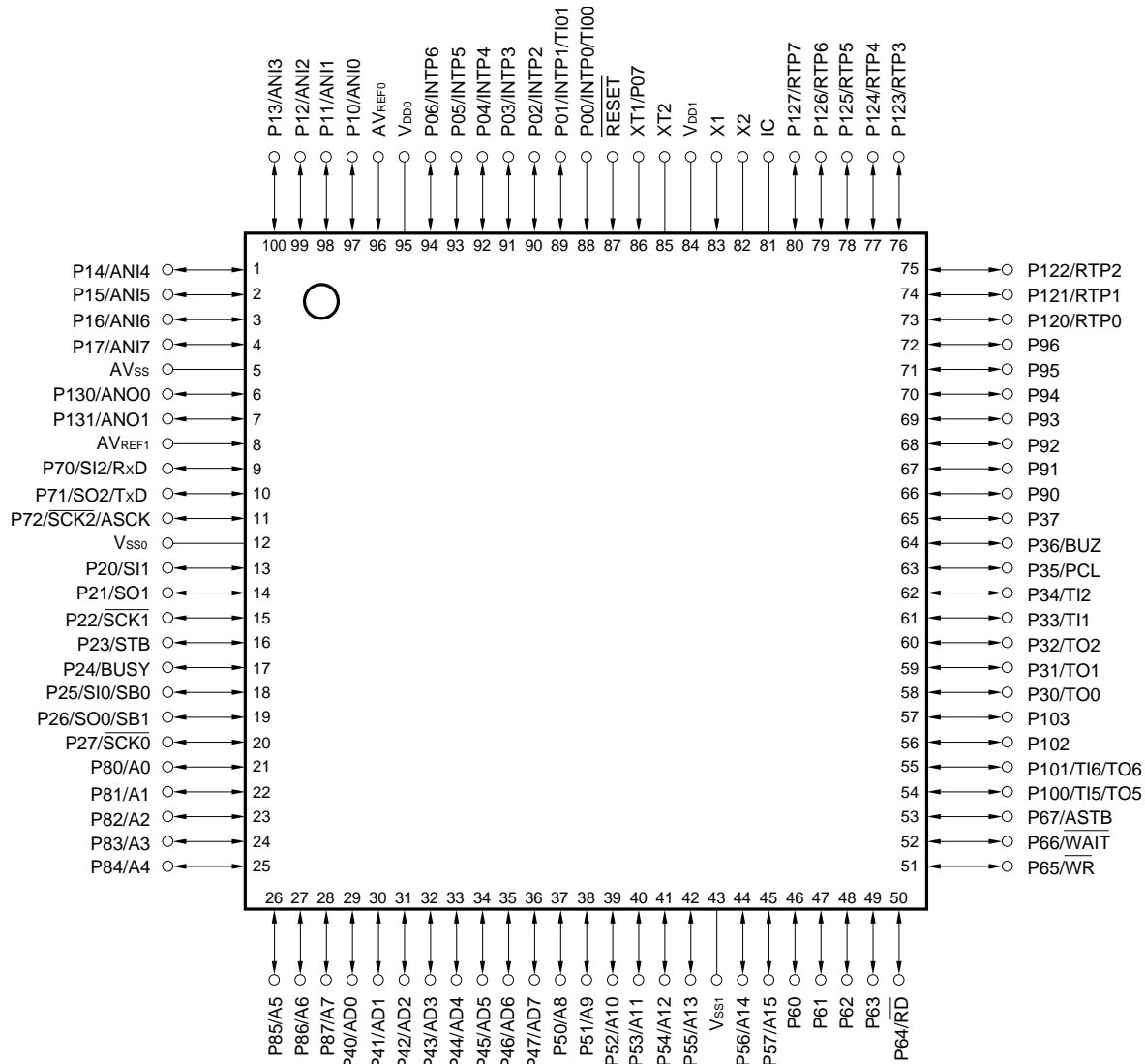

- Cautions**
1. Connect IC (Internally Connected) pin directly to Vss0.
 2. Connect AVss pin to Vss0.

Remark When the μPD78074B and 78075B are used in applications where the noise generated inside the microcontroller needs to be reduced, the implementation of noise reduction measures, such as supplying voltage to VDD0 and VDD1 individually and connecting VSS0 and VSS1 to different ground lines, is recommended.

A0 to A15	: Address Bus	PCL	: Programmable Clock
AD0 to AD7	: Address/Data Bus	RD	: Read Strobe
ANI0 to ANI7	: Analog Input	RESET	: Reset
ANO0, ANO1	: Analog Output	RTP0 to RTP7	: Real-Time Output Port
ASCK	: Asynchronous Serial Clock	RxD	: Receive Data
ASTB	: Address Strobe	SB0, SB1	: Serial Bus
AVREF0, AVREF1	: Analog Reference Voltage	SCK0 to SCK2	: Serial Clock
AVSS	: Analog Ground	SI0 to SI2	: Serial Input
BUSY	: Busy	SO0 to SO2	: Serial Output
BUZ	: Buzzer Clock	STB	: Strobe
IC	: Internally Connected	TI00, TI01, TI1, TI2, TI5, TI6	: Timer Input
INTP0 to INTP6	: Interrupt from Peripherals	TO0 to TO2, TO5, TO6	: Timer Output
P00 to P07	: Port0	TxD	: Transmit Data
P10 to P17	: Port1	VDD0, VDD1	: Power Supply
P20 to P27	: Port2	VSS0, VSS1	: Ground
P30 to P37	: Port3	WAIT	: Wait
P40 to P47	: Port4	WR	: Write Strobe
P50 to P57	: Port5	X1, X2	: Crystal (Main System Clock)
P60 to P67	: Port6	XT1, XT2	: Crystal (Subsystem Clock)
P70 to P72	: Port7		
P80 to P87	: Port8		
P90 to P96	: Port9		
P100 to P103	: Port10		
P120 to P127	: Port12		
P130, P131	: Port13		

2. BLOCK DIAGRAM

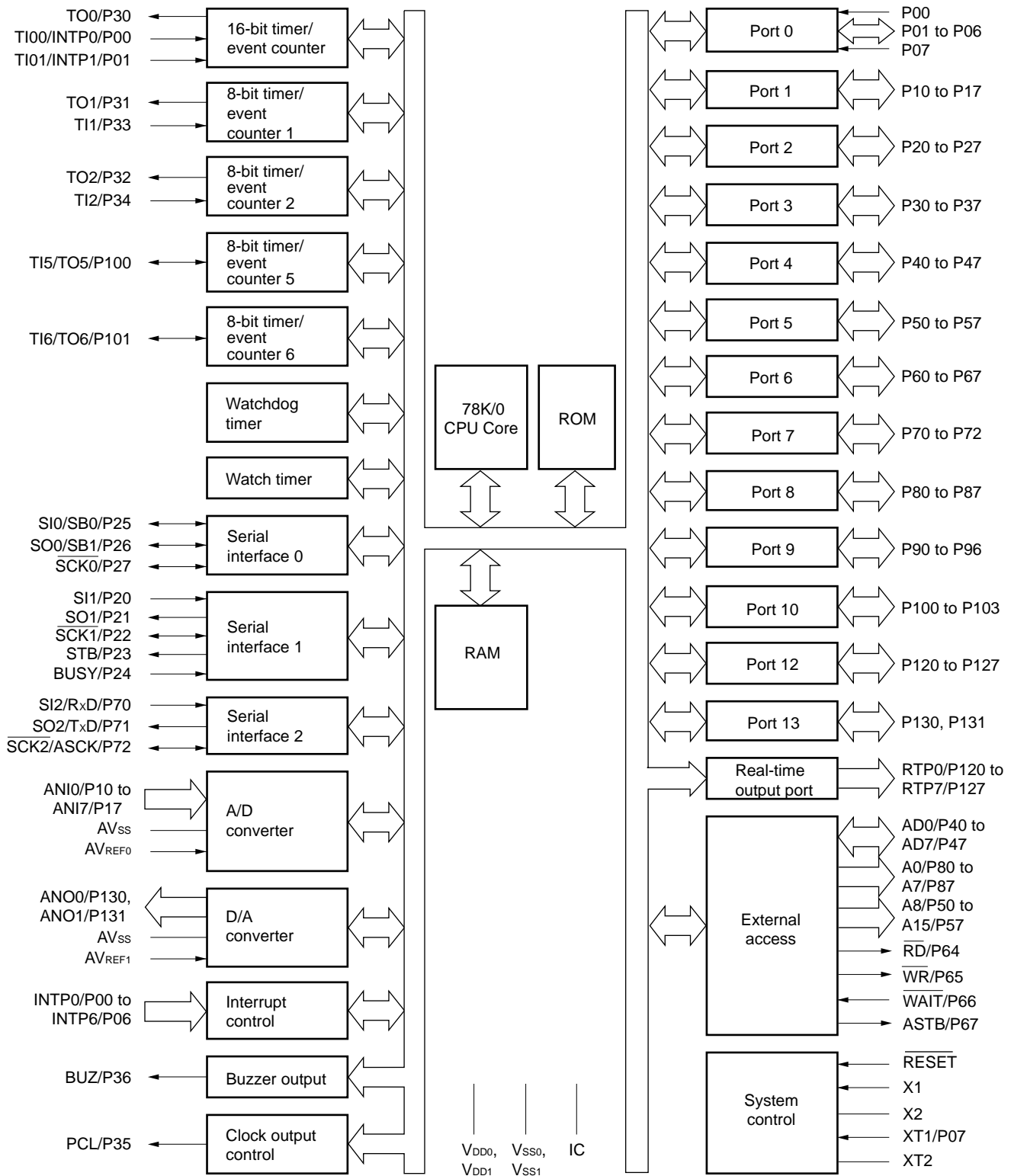

Remark The internal ROM capacity depends on the product.

3. PIN FUNCTIONS

3.1 Port Pins (1/2)

Pin Name	I/O	Function		After Reset	Shared by:
P00	Input	Port 0 8-bit input/output port	Input only	Input	INTP0/TI00
P01	Input/ output		Input/output can be specified bit-wise. When used as an input port, on-chip pull-up resistor can be used by software.	Input	INTP1/TI01
P02					INTP2
P03					INTP3
P04					INTP4
P05					INTP5
P06					INTP6
P07 ^{Note 1}	Input		Input only	Input	XT1
P10 to P17	Input/ output	Port 1 8-bit input/output port Input/output can be specified bit-wise. When used as an input port, on-chip pull-up resistor can be used by software. ^{Note 2}		Input	ANI0 to ANI7
P20	Input/ output	Port 2 8-bit input/output port Input/output can be specified bit-wise. When used as an input port, on-chip pull-up resistor can be used by software.	Input	SI1	
P21				SO1	
P22				SCK1	
P23				STB	
P24				BUSY	
P25				SI0/SB0	
P26				SO0/SB1	
P27				SCK0	
P30	Input/ output	Port 3 8-bit input/output port Input/output can be specified bit-wise. When used as an input port, on-chip pull-up resistor can be used by software.	Input	TO0	
P31				TO1	
P32				TO2	
P33				TI1	
P34				TI2	
P35				PCL	
P36				BUZ	
P37				—	
P40 to P47	Input/ output	Port 4 8-bit input/output port Input/output can be specified in 8-bit units. When used as an input port, on-chip pull-up resistor can be used by software. Test input flag (KRIF) is set to 1 by falling edge detection.		Input	AD0 to AD7

Notes 1. When using the P07/XT1 pin as an input port, set 1 to bit 6 (FRC) of the processor clock control register (PCC). (Do not use the on-chip feedback resistor of the subsystem clock oscillator.)

2. When using the P10/ANI0 to P17/ANI7 pins as the A/D converter analog input, on-chip pull-up resistor is automatically disconnected.

3.1 Port Pins (2/2)

Pin Name	I/O	Function		After Reset	Shared by:
P50 to P57	Input/output	Port 5 8-bit input/output port LED can be driven directly. Input/output can be specified bit-wise. When used as an input port, on-chip pull-up resistor can be used by software.		Input	A8 to A15
P60	Input/output	Port 6 8-bit input/output port Input/output can be specified bit-wise.	N-ch open-drain input/output port. On-chip pull-up resistor can be specified by mask option. LED can be driven directly.	Input	—
P61					
P62					
P63					
P64		When used as an input port, on-chip pull-up resistor can be used by software.	Input	\overline{RD}	
P65				\overline{WR}	
P66				\overline{WAIT}	
P67				ASTB	
P70	Input/output	Port 7 3-bit input/output port Input/output can be specified bit-wise. When used as an input port, on-chip pull-up resistor can be used by software.		Input	S_{I2}/R_{xD}
P71					S_{O2}/T_{xD}
P72					$\overline{SCK2}/\overline{ASCK}$
P80 to P87	Input/output	Port 8 8-bit input/output port Input/output can be specified bit-wise. When used as an input port, on-chip pull-up resistor can be used by software.		Input	A0 to A7
P90	Input/output	Port 9 7-bit input/output port Input/output can be specified bit-wise.	N-ch open-drain input/output port. On-chip pull-up resistor can be specified by mask option. LED can be driven directly.	Input	—
P91					
P92					
P93		When used as an input port, on-chip pull-up resistor can be used by software.			
P94					
P95					
P96					
P100	Input/output	Port 10 4-bit input/output port Input/output can be specified bit-wise. When used as an input port, on-chip pull-up resistor can be used by software.		Input	T_{I5}/T_{O5}
P101					T_{I6}/T_{O6}
P102, P103					—
P120 to P127	Input/output	Port 12 8-bit input/output port Input/output can be specified bit-wise. When used as an input port, on-chip pull-up resistor can be used by software.		Input	RTP0 to RTP7
P130, P131	Input/output	Port 13 2-bit input/output port Input/output can be specified bit-wise. When used as an input port, on-chip pull-up resistor can be used by software.		Input	ANO0, ANO1

3.2 Non-port Pins (1/2)

Pin Name	I/O	Function	After Reset	Shared by:
INTP0	Input	External interrupt request input by which the active edge (rising edge, falling edge, or both rising and falling edges) can be specified	Input	P00/TI00
INTP1				P01/TI01
INTP2				P02
INTP3				P03
INTP4				P04
INTP5				P05
INTP6				P06
SI0	Input	Serial interface serial data input	Input	P25/SB0
SI1				P20
SI2				P70/RxD
SO0	Output	Serial interface serial data output	Input	P26/SB1
SO1				P21
SO2				P71/TxD
SB0	Input/output	Serial interface serial data input/output	Input	P25/SI0
SB1				P26/SO0
$\overline{SCK0}$	Input/output	Serial interface serial clock input/output	Input	P27
SCK1				P22
$\overline{SCK2}$				P72/ASCK
STB	Output	Serial interface automatic transmit/receive strobe output	Input	P23
BUSY	Input	Serial interface automatic transmit/receive busy input	Input	P24
RxD	Input	Asynchronous serial interface serial data input	Input	P70/SI2
TxD	Output	Asynchronous serial interface serial data output	Input	P71/SO2
ASCK	Input	Asynchronous serial interface serial clock input	Input	P72/ $\overline{SCK2}$
TI00	Input	External count clock input to 16-bit timer (TM0)	Input	P00/INTP0
TI01		Capture trigger signal input to capture register (CR00)		P01/INTP1
TI1		External count clock input to 8-bit timer (TM1)		P33
TI2		External count clock input to 8-bit timer (TM2)		P34
TI5		External count clock input to 8-bit timer (TM5)		P100/TO5
TI6		External count clock input to 8-bit timer (TM6)		P101/TO6
TO0	Output	16-bit timer output (also used for 14-bit PWM output)	Input	P30
TO1		8-bit timer output		P31
TO2				P32
TO5		8-bit timer output (also used for 8-bit PWM output)		P100/TI5
TO6				P101/TI6
PCL	Output	Clock output (for main system clock, subsystem clock trimming)	Input	P35
BUZ	Output	Buzzer output	Input	P36

3.2 Non-port Pins (2/2)

Pin Name	I/O	Function	After Reset	Shared by:
RTP0 to RTP7	Output	Real-time output port by which data is output in synchronization with a trigger	Input	P120 to P127
AD0 to AD7	Input/output	Low-order address/data bus at external memory expansion	Input	P40 to P47
A0 to A7	Output	Low-order address bus at external memory expansion	Input	P80 to P87
A8 to A15	Output	High-order address bus at external memory expansion	Input	P50 to P57
\overline{RD}	Output	External memory read operation strobe signal output	Input	P64
\overline{WR}		External memory write operation strobe signal output		P65
\overline{WAIT}	Input	Wait insertion at external memory access	Input	P66
ASTB	Output	Strobe output which externally latches the address information output to ports 4, 5 and 8 to access external memory	Input	P67
ANI0 to ANI7	Input	A/D converter analog input	Input	P10 to P17
ANO0, ANO1	Output	D/A converter analog output	Input	P130, P131
AV _{REF0}	Input	A/D converter reference voltage input (also used for analog power supply)	—	—
AV _{REF1}	Input	D/A converter reference voltage input	—	—
AV _{SS}	—	A/D converter ground potential. The same potential as V _{SS0} .	—	—
\overline{RESET}	Input	System reset input	—	—
X1	Input	Main system clock oscillation crystal connection	—	—
X2	—		—	—
XT1	Input	Subsystem clock oscillation crystal connection	Input	P07
XT2	—		—	—
V _{DD0}	—	Positive power supply of ports	—	—
V _{SS0}	—	Ground potential of ports	—	—
V _{DD1}	—	Positive power supply (except ports and analog)	—	—
V _{SS1}	—	Ground potential (except ports and analog)	—	—
IC	—	Internal connection. Connect directly to V _{SS0} .	—	—

3.3 Pin I/O Circuits and Recommended Connection of Unused Pins

The input/output circuit type of each pin and recommended connection of unused pins are shown in Table 3-1. For the input/output circuit configuration of each type, see Figure 3-1.

Table 3-1. Types of Pin Input/Output Circuits (1/2)

Pin Name	Input/Output Circuit Type	I/O	Recommended Connection for Unused Pins		
P00/INTP0/TI00	2	Input	Connect to V _{SS0} .		
P01/INTP1/TI01	8-C	Input/output	Connect to V _{SS0} via a resistor individually.		
P02/INTP2					
P03/INTP3					
P04/INTP4					
P05/INTP5					
P06/INTP6					
P07/XT1	16	Input	Connect to V _{DD0} .		
P10/ANI0 to P17/ANI7	11-B	Input/output	Connect to V _{DD0} or V _{SS0} via a resistor individually.		
P20/SI1	8-C				
P21/SO1	5-H				
P22/SCK1	8-C				
P23/STB	5-H				
P24/BUSY	8-C				
P25/SI0/SB0	10-B				
P26/SO0/SB1					
P27/SCK0					
P30/TO0	5-H				
P31/TO1					
P32/TO2					
P33/TI1	8-C				
P34/TI2					
P35/PCL	5-H				
P36/BUZ					
P37					
P40/AD0 to P47/AD7				5-N	Input/output
P50/A8 to P57/A15	5-H			Input/output	Connect to V _{DD0} or V _{SS0} via a resistor individually.
P60 to P63	13-J	Input/output	Connect to V _{DD0} via a resistor individually.		
P64/RD	5-H	Input/output	Connect to V _{DD0} or V _{SS0} via a resistor individually.		
P65/WR					
P66/WAIT					
P67/ASTB					

Table 3-1. Types of Pin Input/Output Circuits (2/2)

Pin Name	Input/Output Circuit Type	I/O	Recommended Connection for Unused Pins
P70/SI2/RxD	8-C	Input/output	Connect to V _{DD0} or V _{SS0} via a resistor individually.
P71/SO2/TxD	5-H		
P72/SCK2/ASCK	8-C		
P80/A0 to P87/A7	5-H		
P90 to P93	13-J	Input/output	Connect to V _{DD0} via a resistor individually.
P94 to P96	5-H	Input/output	Connect to V _{DD0} or V _{SS0} via a resistor individually.
P100/TI5/TO5	8-C		
P101/TI6/TO6			
P102, P103	5-H		
P120/RTP0 to P127/RTP7			
P130/ANO0, P131/ANO1	12-C	Input/output	Connect to V _{SS0} via a resistor individually.
RESET	2	Input	—
XT2	16	—	Leave open.
AV _{REF0}	—		Connect to V _{SS0} .
AV _{REF1}			Connect to V _{DD0} .
AV _{SS}			Connect to V _{SS0} .
IC			Connect directly to V _{SS0} .

Figure 3-1. Pin Input/Output Circuits (1/2)

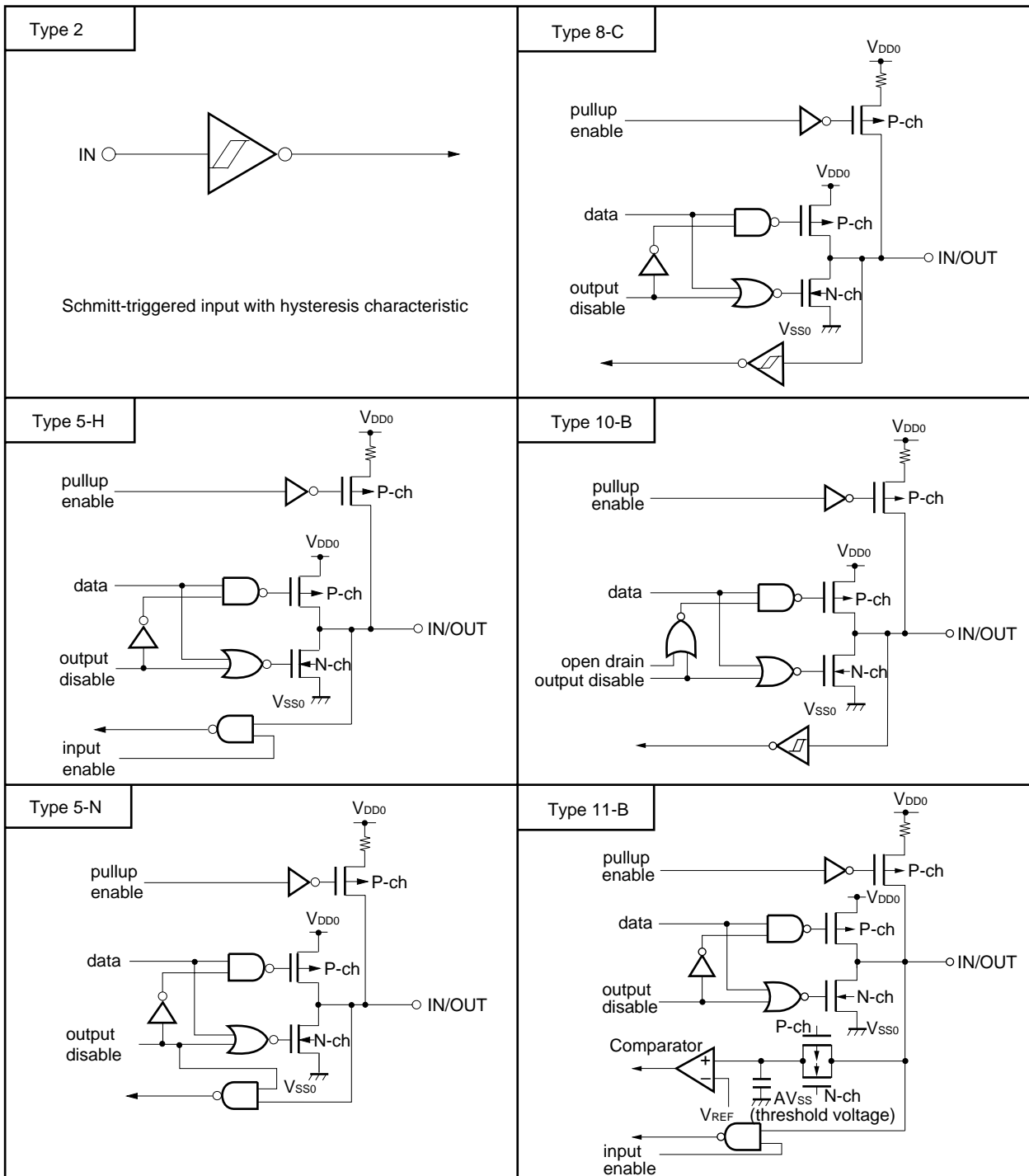
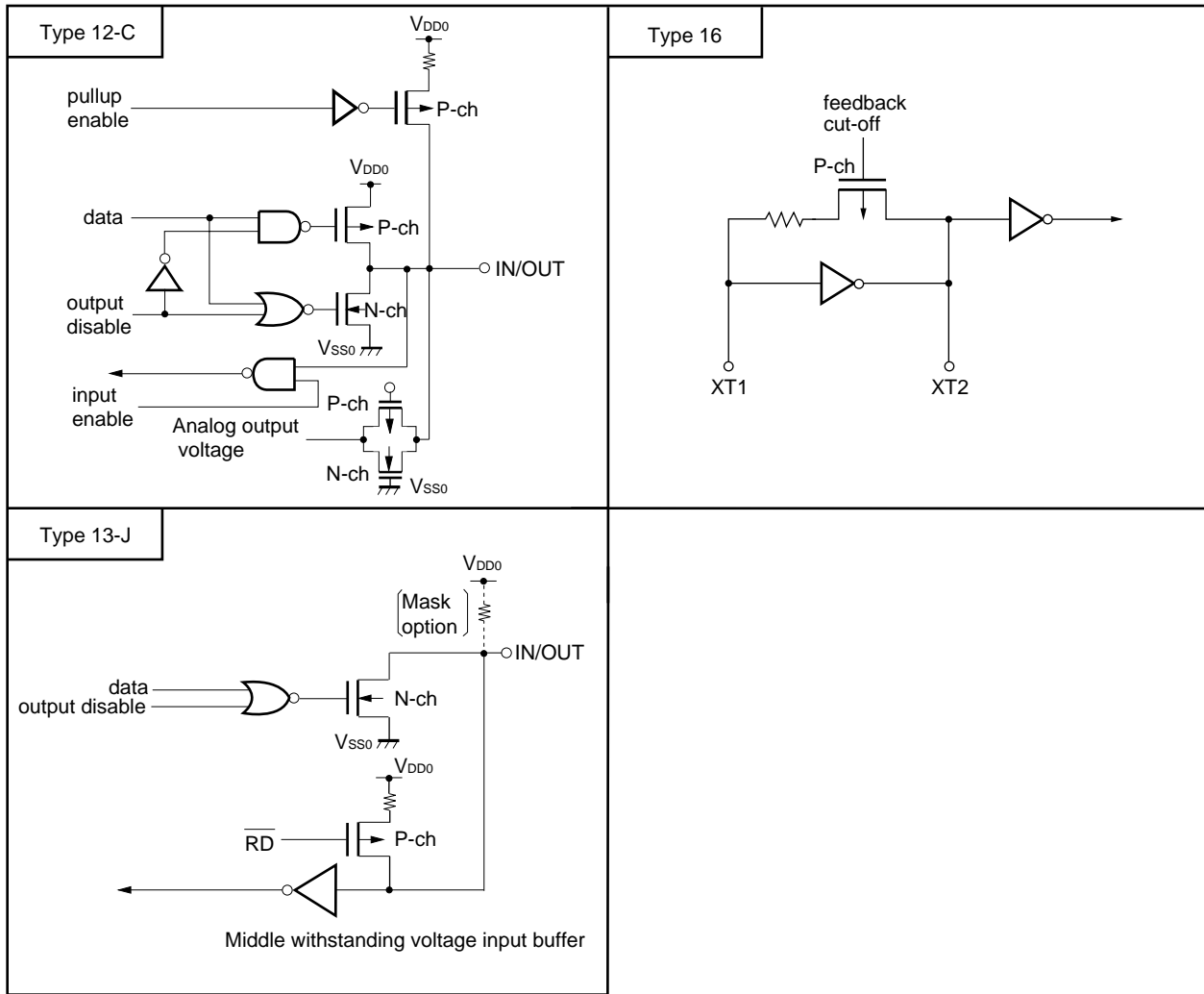

Figure 3-1. Pin Input/Output Circuits (2/2)



4. MEMORY SPACE

The memory map of the μPD78074B and 78075B is shown in Figure 4-1.

Figure 4-1. Memory Map

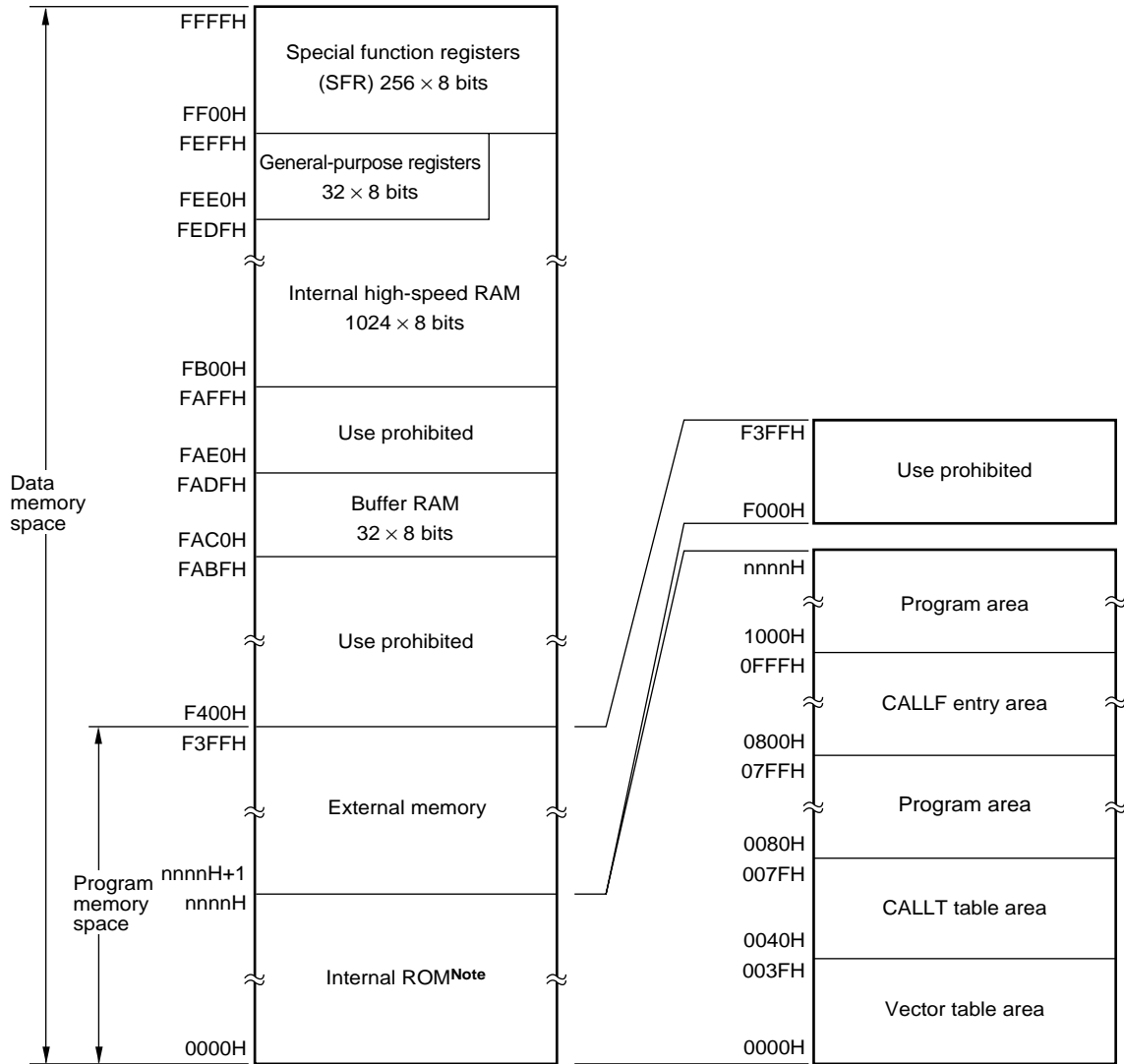

Note The internal ROM capacity depends on the product (see the following table).

Part Number	Internal ROM Last Address nnnnH
μPD78074B	7FFFH
μPD78075B	9FFFH

5. PERIPHERAL HARDWARE FUNCTIONS

5.1 Ports

Input/output ports are classified into three types.

- CMOS input (P00, P07) : 2
 - CMOS input/output (P01 to P06, Ports 1 to 5, P64 to P67, Port 7, Port 8, P94 to P96, Port 10, Port 12, Port 13) : 78
 - N-ch open-drain input/output (P60 to P63, P90 to P93) : 8
-
- Total : 88

Table 5-1. Functions of Ports

Port Name	Pin Name	Function
Port 0	P00, P07	Input only
	P01 to P06	Input/output port. Input/output can be specified bit-wise. When used as an input port, on-chip pull-up resistor can be used by software.
Port 1	P10 to P17	Input/output port. Input/output can be specified bit-wise. When used as an input port, on-chip pull-up resistor can be used by software.
Port 2	P20 to P27	Input/output port. Input/output can be specified bit-wise. When used as an input port, on-chip pull-up resistor can be used by software.
Port 3	P30 to P37	Input/output port. Input/output can be specified bit-wise. When used as an input port, on-chip pull-up resistor can be used by software.
Port 4	P40 to P47	Input/output port. Input/output can be specified in 8-bit units. When used as an input port, on-chip pull-up resistor can be used by software. The test input flag (KRIF) is set to 1 by falling edge detection.
Port 5	P50 to P57	Input/output port. Input/output can be specified bit-wise. When used as an input port, on-chip pull-up resistor can be used by software. LED can be driven directly.
Port 6	P60 to P63	N-ch open-drain input/output port. Input/output can be specified bit-wise. On-chip pull-up resistor can be used by mask option. LED can be driven directly.
	P64 to P67	Input/output port. Input/output can be specified bit-wise. When used as an input port, on-chip pull-up resistor can be used by software.
Port 7	P70 to P72	Input/output port. Input/output can be specified bit-wise. When used as an input port, on-chip pull-up resistor can be used by software.
Port 8	P80 to P87	Input/output port. Input/output can be specified bit-wise. When used as an input port, on-chip pull-up resistor can be used by software.
Port 9	P90 to P93	N-ch open-drain input/output port. Input/output can be specified bit-wise. On-chip pull-up resistor can be used by mask option. LED can be driven directly.
	P94 to P96	Input/output port. Input/output can be specified bit-wise. When used as an input port, on-chip pull-up resistor can be used by software.
Port 10	P100 to P103	Input/output port. Input/output can be specified bit-wise. When used as an input port, on-chip pull-up resistor can be used by software.
Port 12	P120 to P127	Input/output port. Input/output can be specified bit-wise. When used as an input port, on-chip pull-up resistor can be used by software.
Port 13	P130, P131	Input/output port. Input/output can be specified bit-wise. When used as an input port, on-chip pull-up resistor can be used by software.

5.2 Clock Generator

There are two kinds of clock generators: main system and subsystem clock generators.

It is possible to change the instruction execution time.

- 0.4 μs/0.8 μs/1.6 μs/3.2 μs/6.4 μs/12.8 μs (at main system clock frequency of 5.0 MHz)
- 122 μs (at subsystem clock frequency of 32.768 kHz)

Figure 5-1. Clock Generator Block Diagram

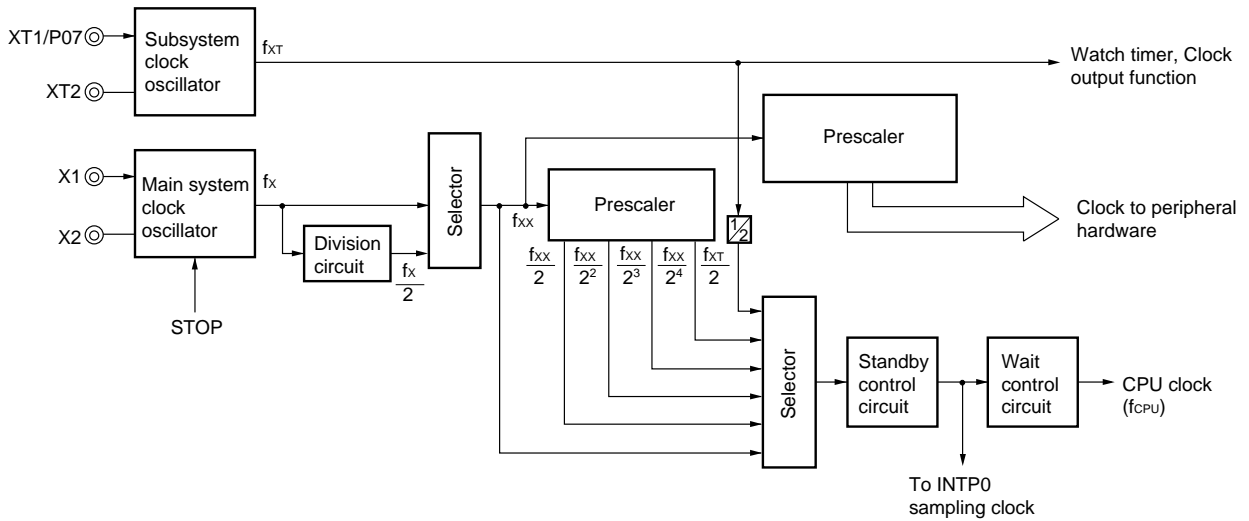

5.3 Timer/Event Counter

There are the following seven timer/event counter channels:

- 16-bit timer/event counter : 1 channel
- 8-bit timer/event counter : 4 channels
- Watch timer : 1 channel
- Watchdog timer : 1 channel

Table 5-2. Types and Functions of Timer/Event Counters

		16-bit Timer/Event Counter	8-bit Timer/Event Counter 1, 2	8-bit Timer/Event Counter 5, 6	Watch Timer	Watchdog Timer
Type	Interval timer	1 channel	2 channels	2 channels	1 channel	1 channel
	External event counter	1 channel	2 channels	2 channels	—	—
Function	Timer output	1 output	2 outputs	2 outputs	—	—
	PWM output	1 output	—	2 outputs	—	—
	Pulse width measurement	2 inputs	—	—	—	—
	Square wave output	1 output	2 outputs	2 outputs	—	—
	One-shot pulse output	1 output	—	—	—	—
	Interrupt request	2	2	2	1	1
	Test input	—	—	—	1 input	—

Figure 5-2. 16-Bit Timer/Event Counter Block Diagram

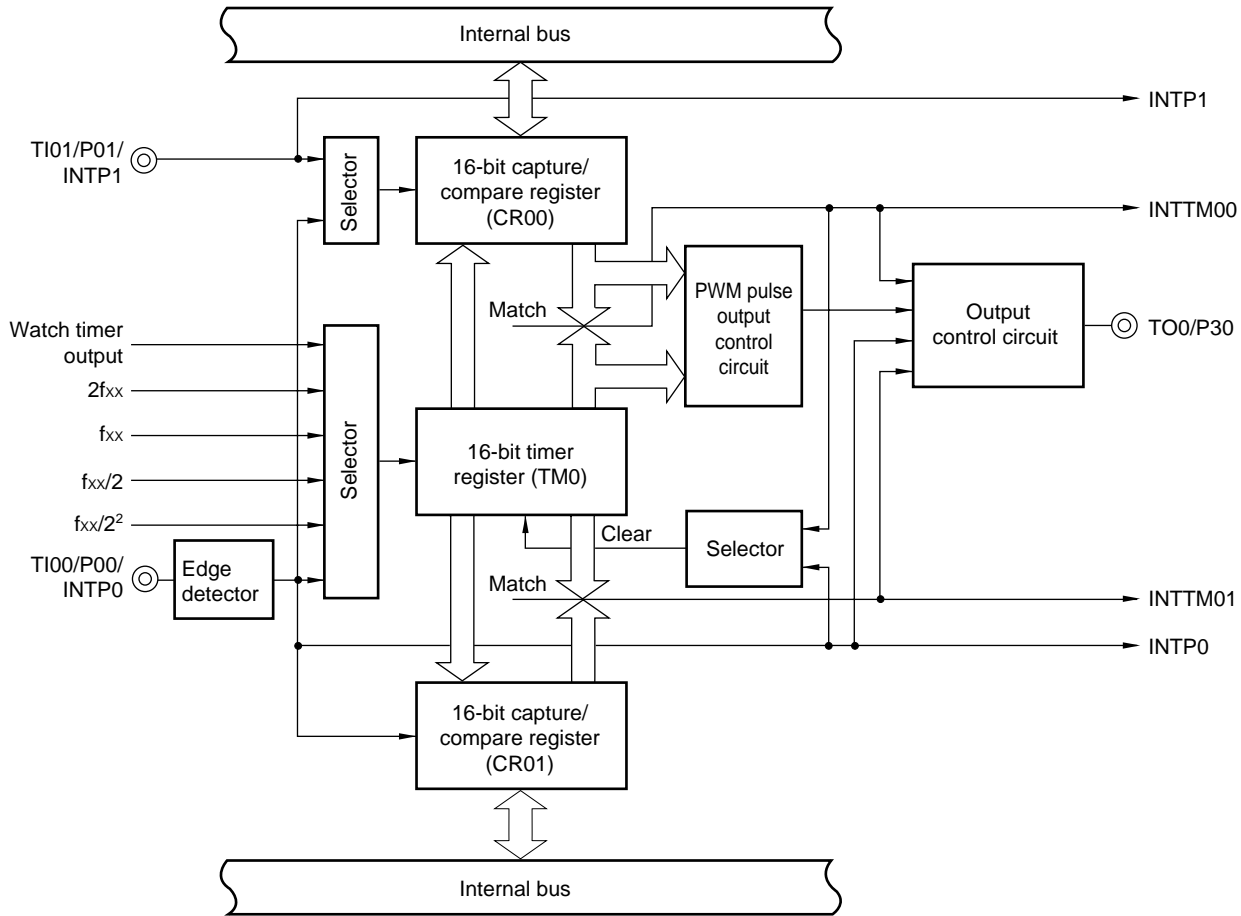

Figure 5-3. 8-Bit Timer/Event Counter 1, 2 Block Diagram

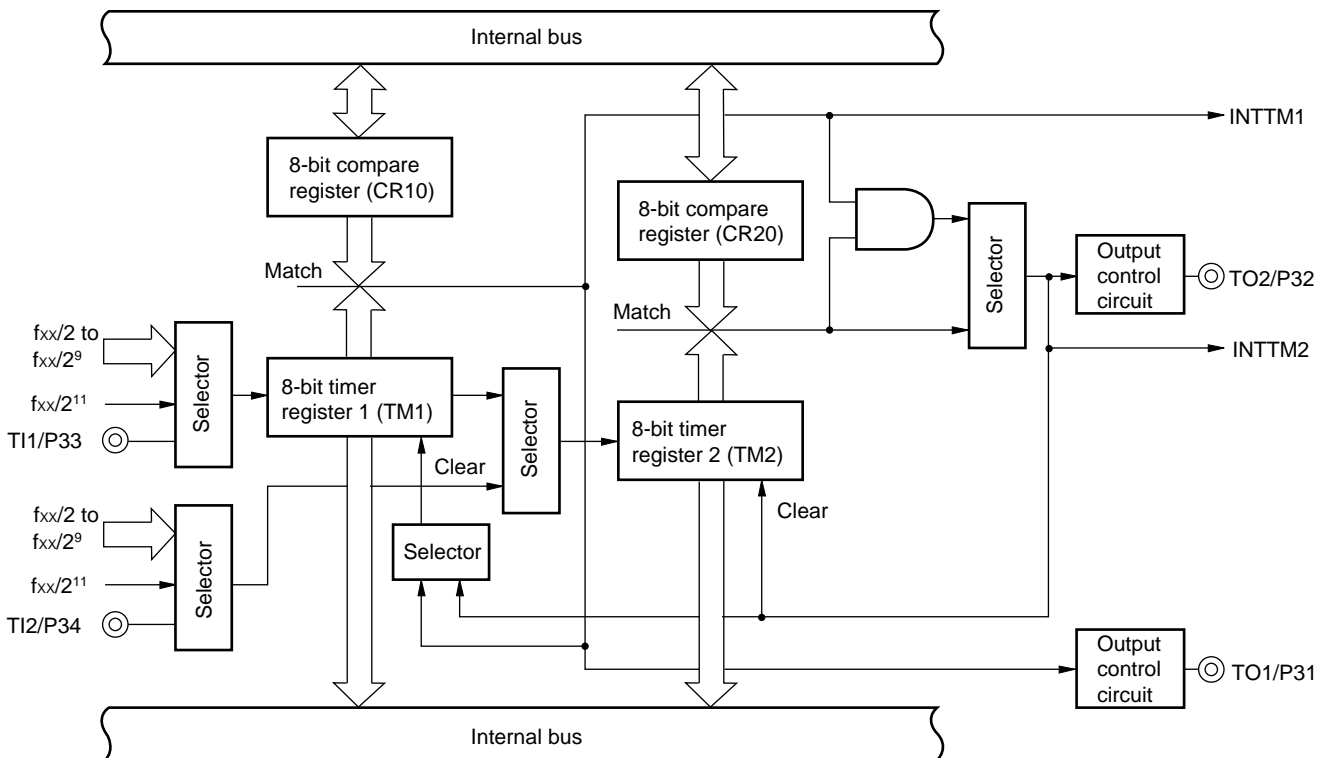
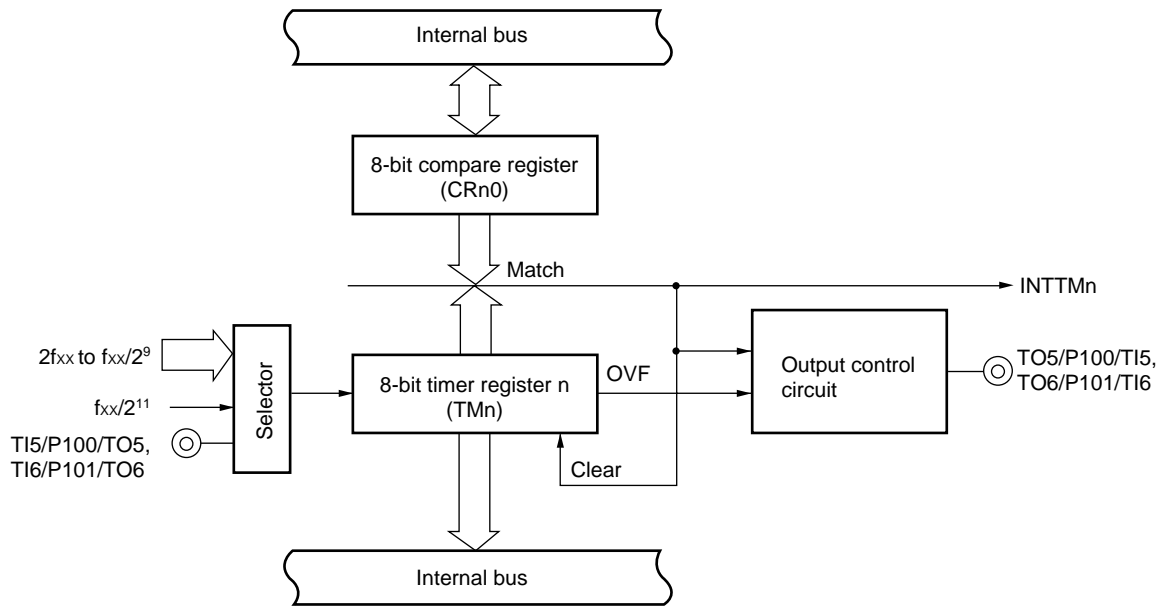

Figure 5-4. 8-Bit Timer/Event Counter 5, 6 Block Diagram



n = 5, 6

Figure 5-5. Watch Timer Block Diagram

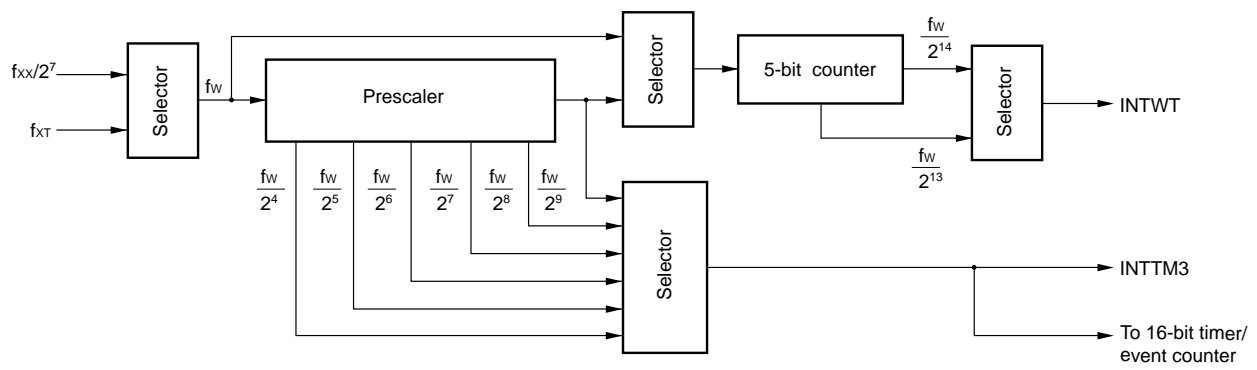
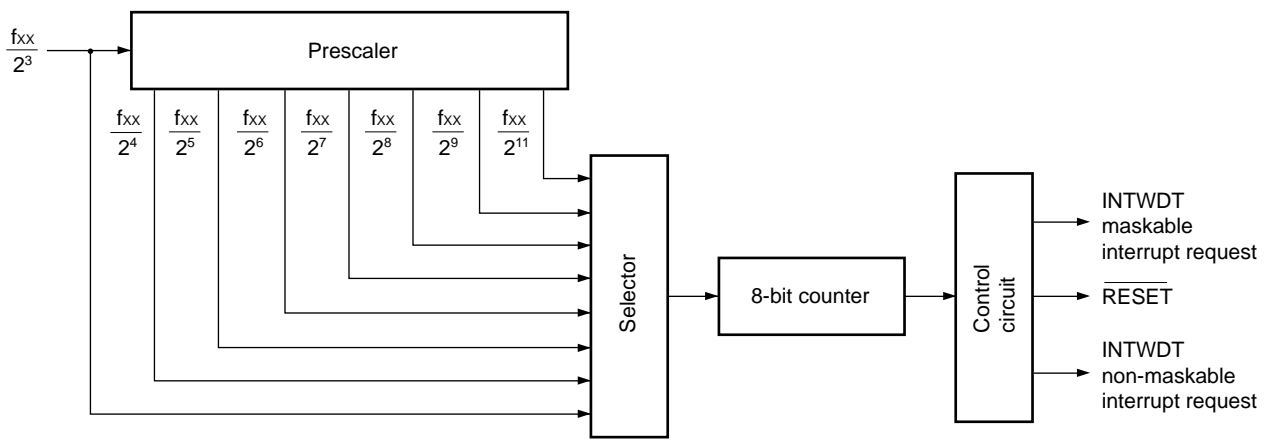

Figure 5-6. Watchdog Timer Block Diagram



5.4 Clock Output Control Circuit

This circuit can output clocks of the following frequencies:

- 19.5 kHz/39.1 kHz/78.1 kHz/156 kHz/313 kHz/625 kHz/1.25 MHz/2.5 MHz/5.0 MHz (at main system clock frequency of 5.0 MHz)
- 32.768 kHz (at subsystem clock frequency of 32.768 kHz)

Figure 5-7. Clock Output Control Circuit Block Diagram

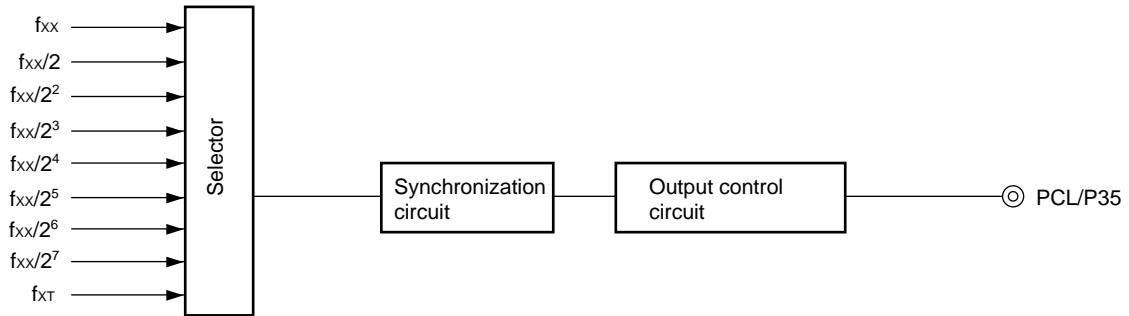

5.5 Buzzer Output Control Circuit

This circuit can output clocks of the following frequencies that can be used for driving buzzers:

- 1.2 kHz/2.4 kHz/4.9 kHz/9.8 kHz (at main system clock frequency of 5.0 MHz)

Figure 5-8. Buzzer Output Control Circuit Block Diagram

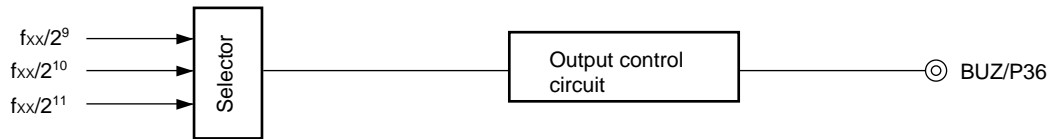

5.6 A/D Converter

The A/D converter consists of eight 8-bit resolution channels.

A/D conversion can be started by the following two methods:

- Hardware starting
- Software starting

Figure 5-9. A/D Converter Block Diagram

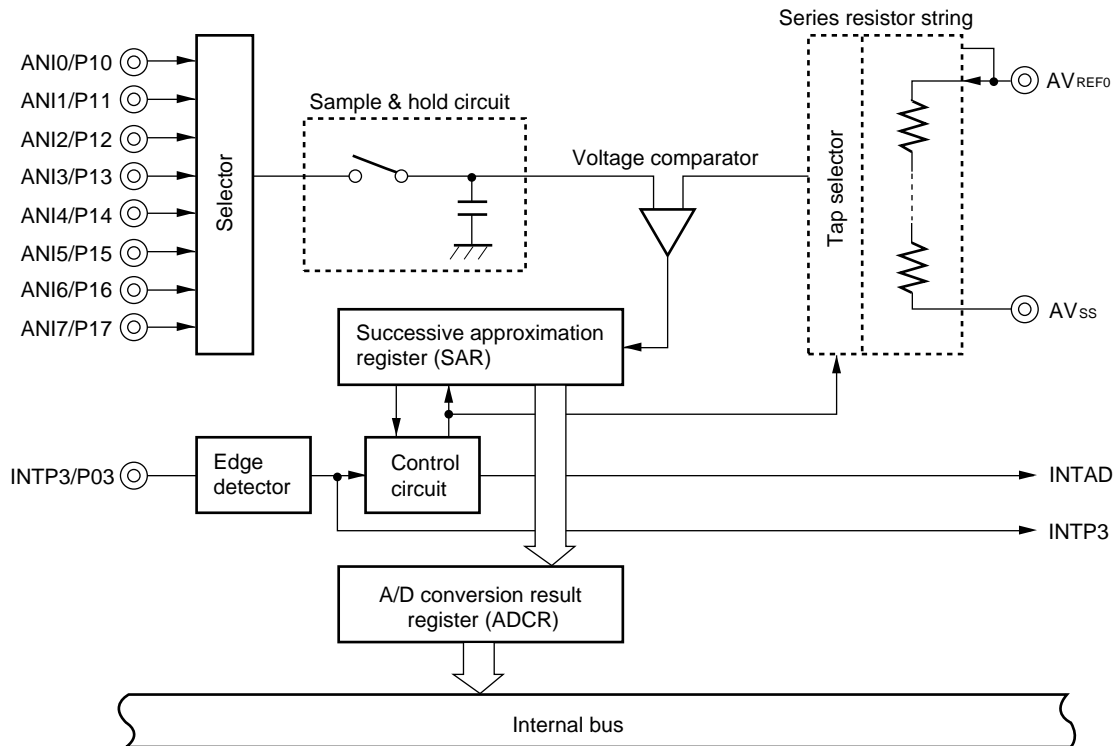

5.7 D/A Converter

The D/A converter consists of two 8-bit resolution channels.

The conversion method is the R-2R resistor ladder method.

Figure 5-10. D/A Converter Block Diagram

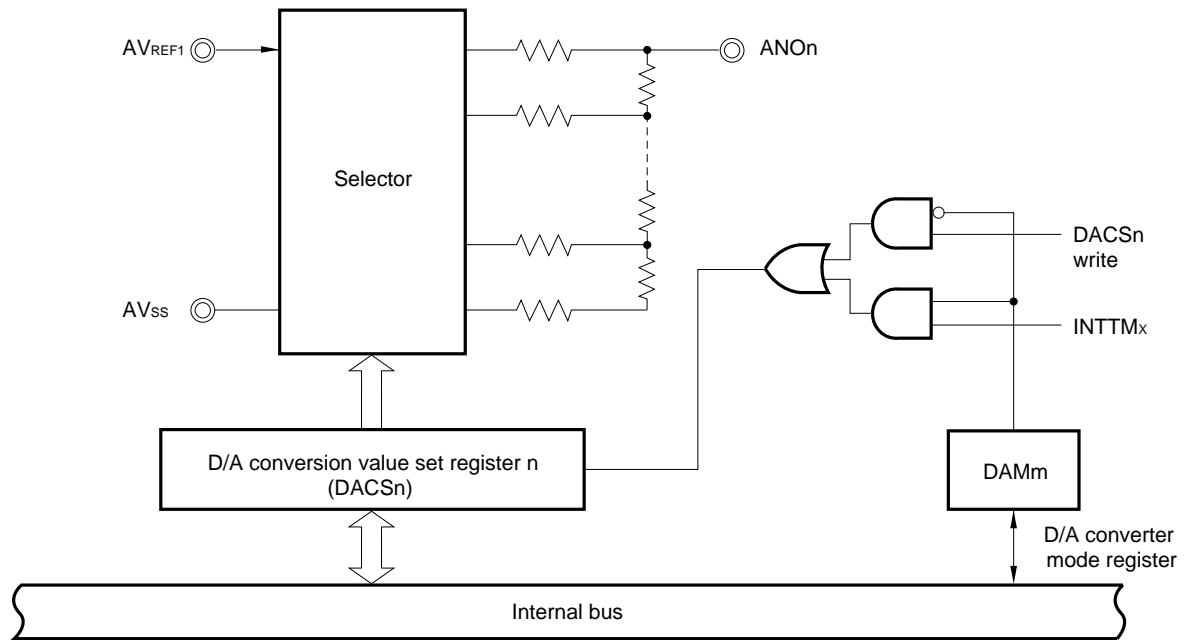

n = 0, 1
 m = 4, 5
 x = 1, 2

5.8 Serial Interfaces

There are the following three on-chip serial interface channels synchronous with the clock:

- Serial interface channel 0
- Serial interface channel 1
- Serial interface channel 2

Table 5-3. Types and Functions of Serial Interfaces

Function	Serial Interface Channel 0	Serial Interface Channel 1	Serial Interface Channel 2
3-wire serial I/O mode	Available (MSB/LSB-first switching possible)	Available (MSB/LSB-first switching possible)	Available (MSB/LSB-first switching possible)
3-wire serial I/O mode with automatic transmit/receive function	—	Available (MSB/LSB-first switching possible)	—
2-wire serial I/O mode	Available (MSB first)	—	—
SBI mode	Available (MSB first)	—	—
Asynchronous serial interface (UART) mode	—	—	Available (On-chip dedicated baud rate generator)

Figure 5-11. Serial Interface Channel 0 Block Diagram

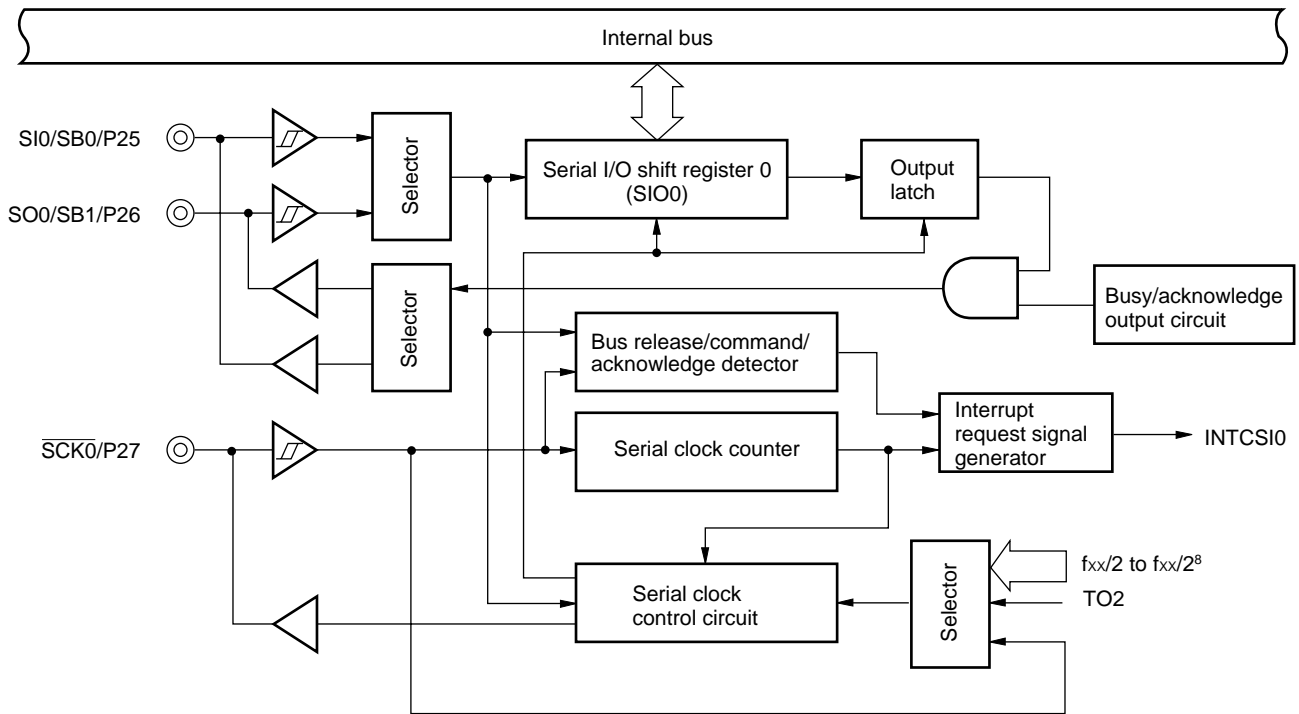

Figure 5-12. Serial Interface Channel 1 Block Diagram

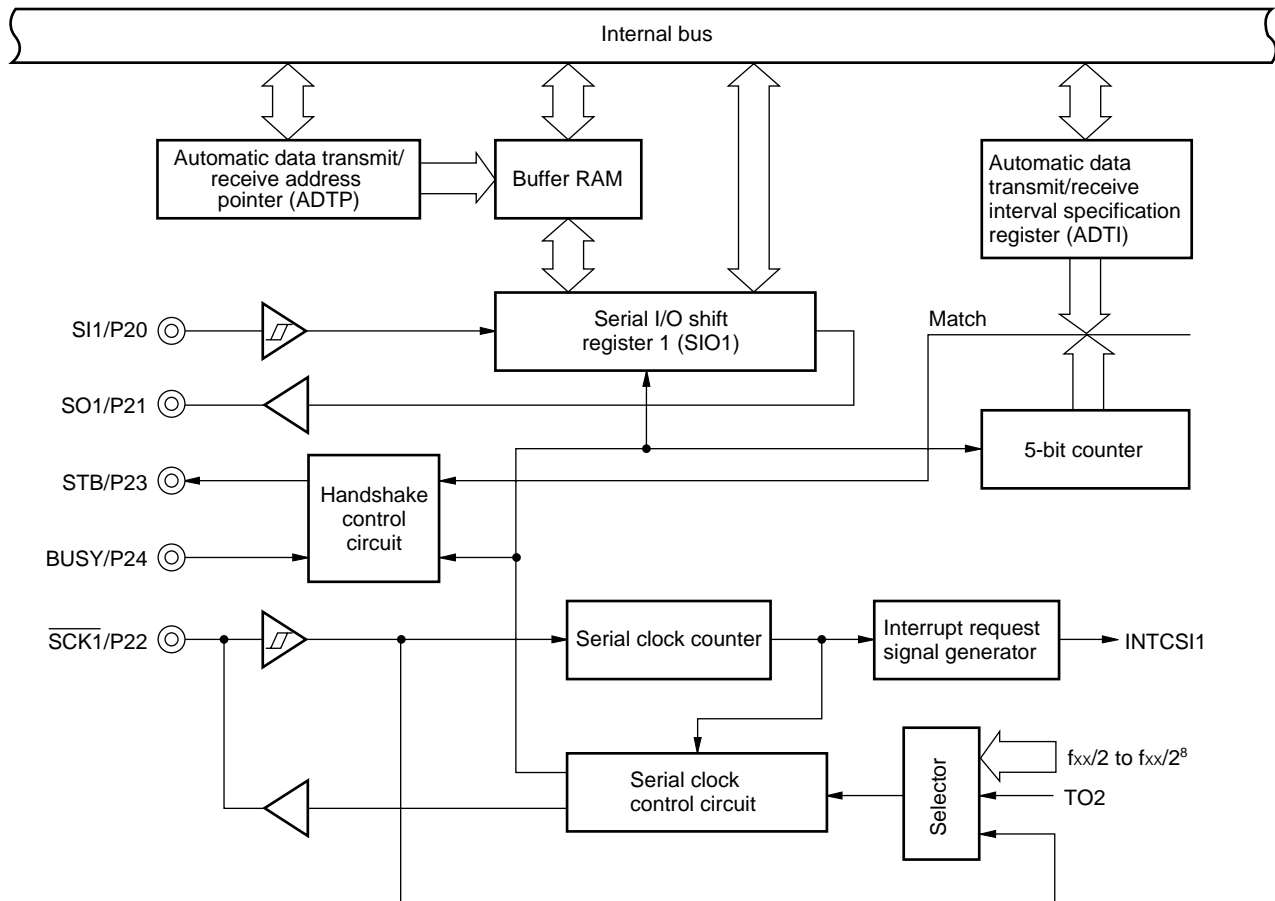
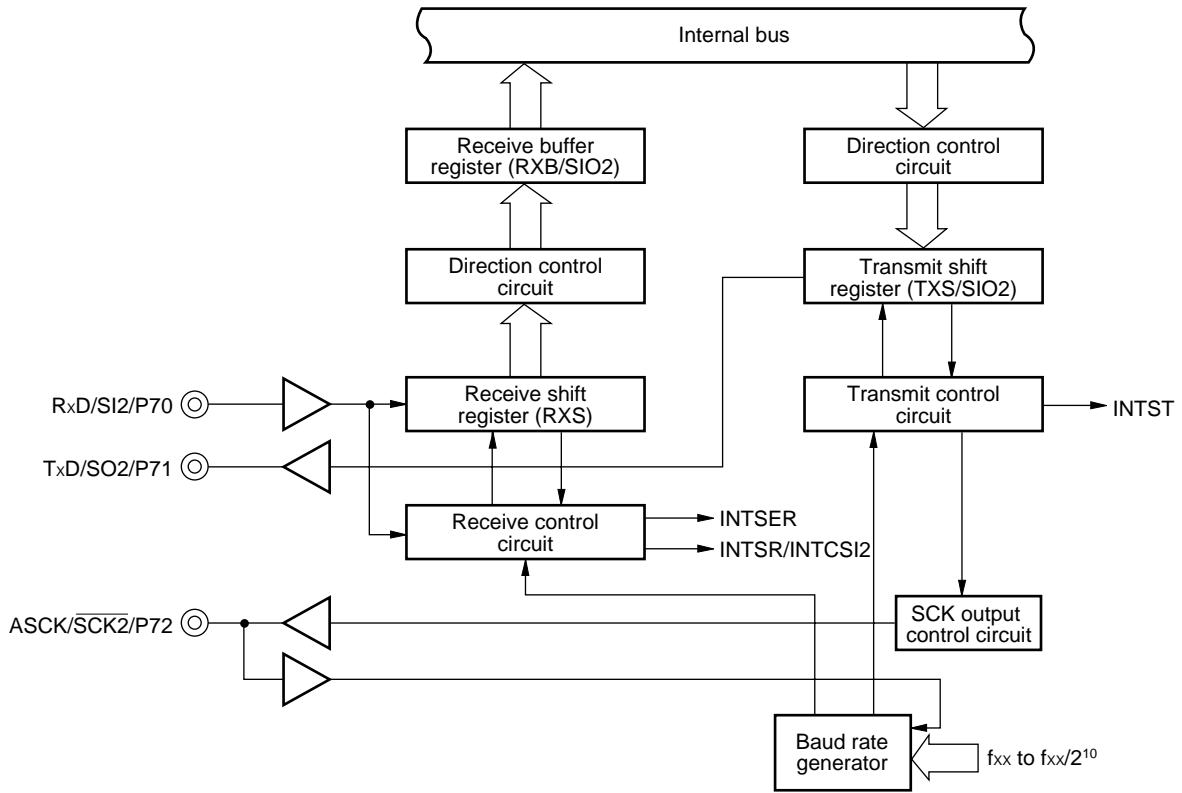

Figure 5-13. Serial Interface Channel 2 Block Diagram



5.9 Real-Time Output Port

Data set previously in the real-time output buffer register is transferred to the output latch by hardware concurrently with timer interrupt request or external interrupt request generation in order to output to off-chip. This is a real-time output function. Pins used to output to off-chip are called real-time output ports.

By using a real-time output port, a signal which has no jitter can be output. This is most applicable to control of stepping motor, etc.

Figure 5-14. Real-Time Output Port Block Diagram

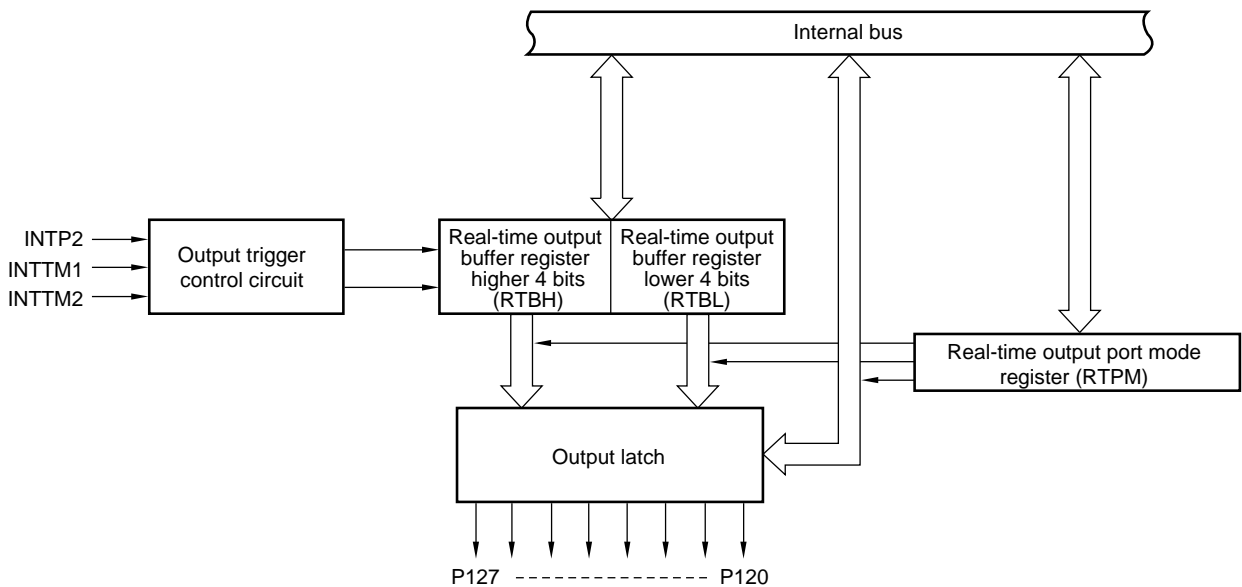

6. INTERRUPT FUNCTIONS AND TEST FUNCTIONS

6.1 Interrupt Functions

A total of 24 interrupt functions are provided, divided into the following three types.

- Non-maskable : 1
- Maskable : 22
- Software : 1

Table 6-1. List of Interrupt Sources

Interrupt Type	Default Priority ^{Note 1}	Interrupt Source		Internal/External	Vector Table Address	Basic Configuration Type ^{Note 2}		
		Name	Trigger					
Non-maskable	—	INTWDT	Overflow of watchdog timer (When the watchdog timer mode 1 is selected)	Internal	0004H	(A)		
Maskable	0	INTWDT	Overflow of watchdog timer (When the interval timer mode is selected)			External	0006H 0008H 000AH 000CH 000EH 0010H 0012H	(B)
	1	INTP0	Pin input edge detection	Internal	0014H 0016H 0018H 001AH 001CH 001EH 0020H 0022H 0024H 0026H 0028H 002AH 002CH			(C)
	2	INTP1						(D)
	3	INTP2						
	4	INTP3						
	5	INTP4						
	6	INTP5						
	7	INTP6						
	8	INTCSI0	Completion of serial interface channel 0 transfer	Internal	0014H 0016H 0018H 001AH 001CH 001EH 0020H 0022H 0024H 0026H 0028H 002AH 002CH	(B)		
	9	INTCSI1	Completion of serial interface channel 1 transfer					
	10	INTSER	Occurrence of serial interface channel 2 UART reception error					
	11	INTSR	Completion of serial interface channel 2 UART reception					
		INTCSI2	Completion of serial interface channel 2 3-wire transfer					
	12	INTST	Completion of serial interface channel 2 UART transmission					
	13	INTTM3	Reference interval signal from watch timer					
	14	INTTM00	Generation of matching signal of 16-bit timer register and capture/compare register (CR00)					
	15	INTTM01	Generation of matching signal of 16-bit timer register and capture/compare register (CR01)					
	16	INTTM1	Generation of matching signal of 8-bit timer/event counter 1					
	17	INTTM2	Generation of matching signal of 8-bit timer/event counter 2					
	18	INTAD	Completion of A/D conversion					
19	INTTM5	Generation of matching signal of 8-bit timer/event counter 5						
20	INTTM6	Generation of matching signal of 8-bit timer/event counter 6						
Software	—	BRK	Execution of BRK instruction	—	003EH	(E)		

Notes 1. Default priority is the priority order when several maskable interrupt requests are generated at the same time. 0 is the highest order and 20 is the lowest order.

2. Basic configuration types (A) to (E) correspond to (A) to (E) in Figure 6-1.

Figure 6-1. Interrupt Function Basic Configuration (1/2)

(A) Internal non-maskable interrupt

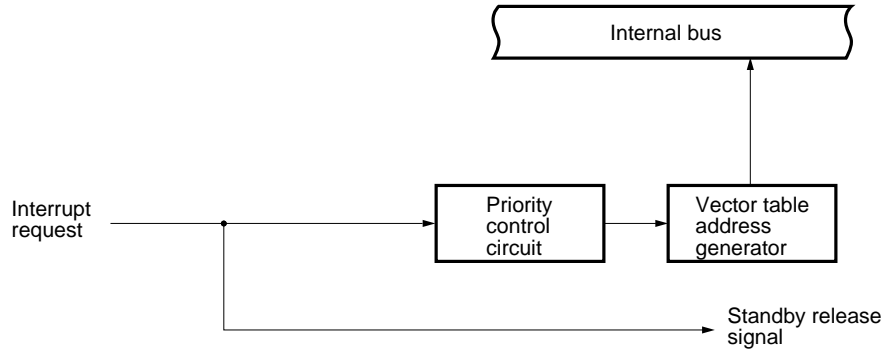

(B) Internal maskable interrupt

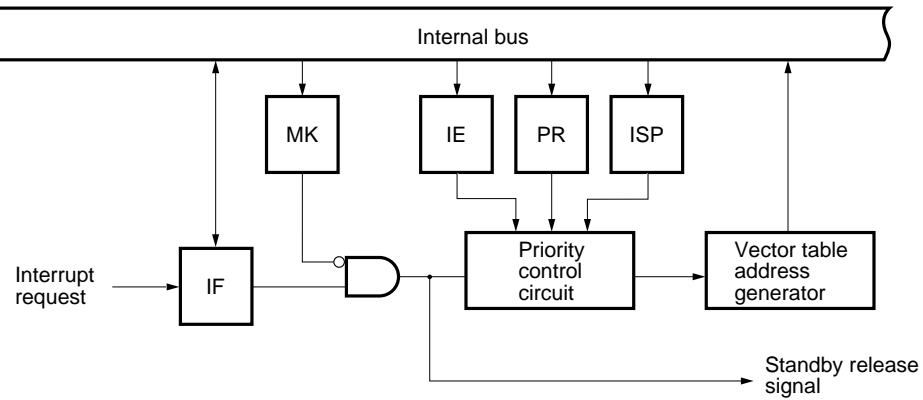

(C) External maskable interrupt (INTP0)

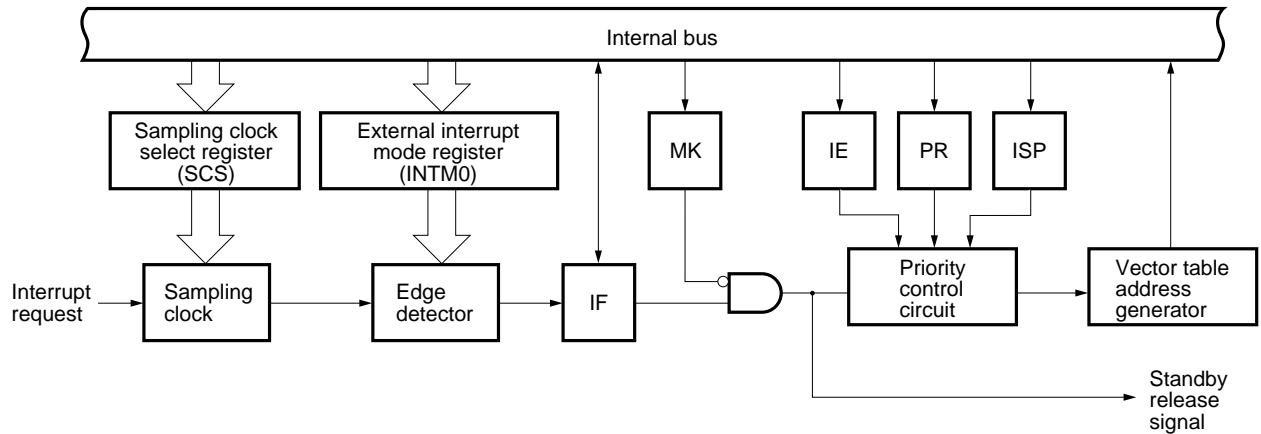
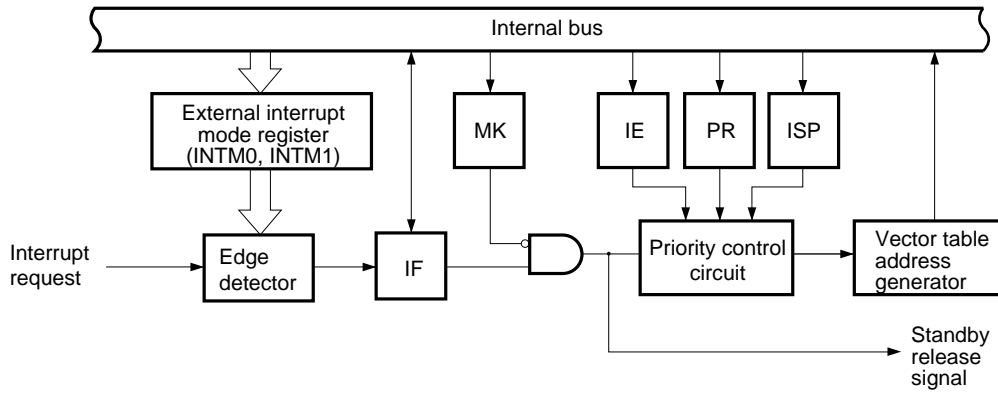
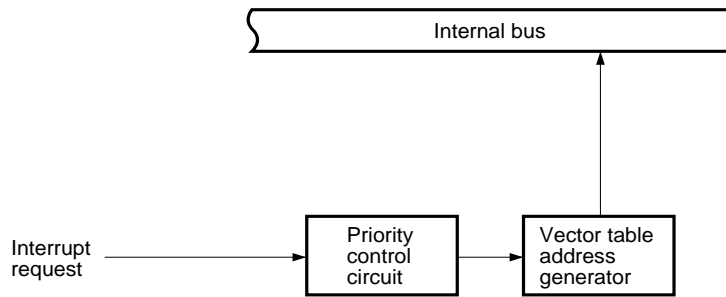

Figure 6-1. Interrupt Function Basic Configuration (2/2)

(D) External maskable interrupt (except INTP0)



(E) Software interrupt



- IF : Interrupt request flag
- IE : Interrupt enable flag
- ISP : In-service priority flag
- MK : Interrupt mask flag
- PR : Priority specification flag

6.2 Test Functions

Table 6-2 shows the two test functions available.

Table 6-2. List of Test Input Sources

Test Input Source		Internal/ External
Name	Trigger	
INTWT	Overflow of watch timer	Internal
INTPT4	Detection of falling edge of port 4	External

Figure 6-2. Basic Configuration of Test Function

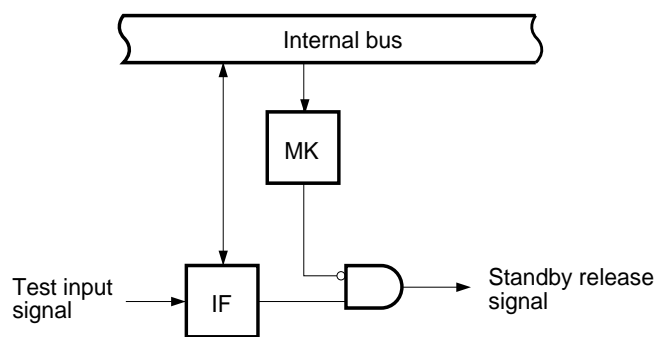

IF : Test input flag
 MK : Test mask flag

7. EXTERNAL DEVICE EXPANSION FUNCTIONS

The external device expansion functions connect external devices to areas other than the internal ROM, RAM and SFR.

External devices connection uses ports 4 to 6 and port 8.

The external device expansion function has the following two modes:

- Separate bus mode : External devices are connected by using an independent address bus and data bus. Because an external latch circuit is not necessary, this mode is effective for reducing the number of components and the mounting area on a printed wiring board.
- Multiplexed bus mode : External devices are connected by using a time-division multiplexed address/data bus. This mode is useful for reducing the number of ports used when external devices are connected.

8. STANDBY FUNCTION

The standby function intends to reduce current consumption. It has the following two modes:

- HALT mode : In this mode, the CPU operation clock is stopped. The average current consumption can be reduced by intermittent operation by combining this mode with the normal operation mode.
- STOP mode : In this mode, oscillation of the main system clock is stopped. All the operations performed on the main system clock are suspended, and only the subsystem clock is used for extremely small power consumption.

Figure 8-1. Standby Function

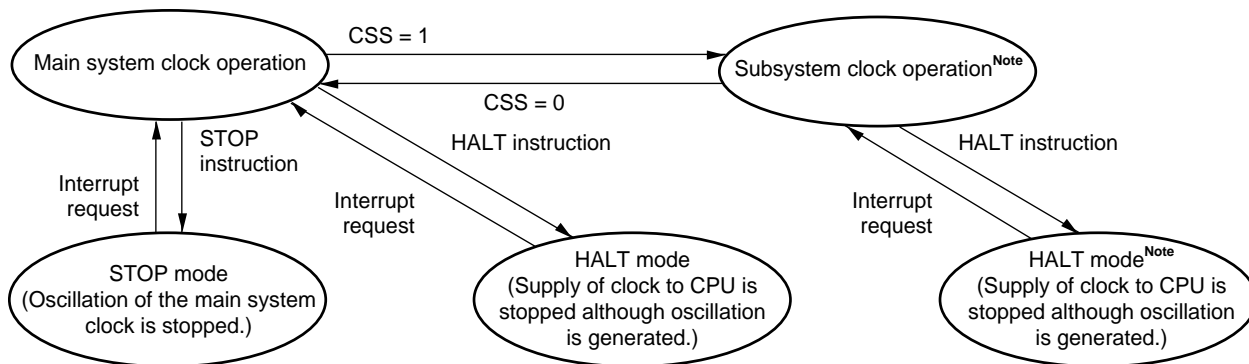

Note Current consumption is reduced by stopping the main system clock.

If the CPU is operating on the subsystem clock, stop the main system clock by setting MCC (bit 7 in the processor clock control register (PCC)). The STOP instruction cannot be used.

Caution When the main system clock is stopped and the system is operated by the subsystem clock, the subsystem clock should be switched again to the main system clock after the oscillation stabilization time is secured by the program.

9. RESET FUNCTION

There are the following two reset methods.

- External reset by $\overline{\text{RESET}}$ pin
- Internal reset by watchdog timer runaway time detection

10. INSTRUCTION SET

(1) 8-bit instructions

MOV, XCH, ADD, ADDC, SUB, SUBC, AND, OR, XOR, CMP, MULU, DIVUW, INC, DEC, ROR, ROL, RORC, ROLC, ROR4, ROL4, PUSH, POP, DBNZ

2nd Operand 1st Operand	#byte	A	r ^{Note}	sfr	saddr	!addr16	PSW	[DE]	[HL]	[HL + byte] [HL + B] [HL + C]	\$addr16	1	None
A	ADD ADDC SUB SUBC AND OR XOR CMP		MOV XCH ADD ADDC SUB SUBC AND OR XOR CMP	MOV XCH	MOV XCH ADD ADDC SUB SUBC AND OR XOR CMP	MOV XCH ADD ADDC SUB SUBC AND OR XOR CMP	MOV	MOV XCH	MOV XCH ADD ADDC SUB SUBC AND OR XOR CMP	MOV XCH ADD ADDC SUB SUBC AND OR XOR CMP		ROR ROL RORC ROLC	
r	MOV	MOV ADD ADDC SUB SUBC AND OR XOR CMP											INC DEC
B, C											DBNZ		
sfr	MOV	MOV											
saddr	MOV ADD ADDC SUB SUBC AND OR XOR CMP	MOV									DBNZ		INC DEC
!addr16		MOV											
PSW	MOV	MOV											PUSH POP
[DE]		MOV											
[HL]		MOV											ROR4 ROL4
[HL + byte] [HL + B] [HL + C]		MOV											
X													MULU
C													DIVUW

Note Except r = A

(2) 16-bit instructions

MOVW, XCHW, ADDW, SUBW, CMPW, PUSH, POP, INCW, DECW

2nd Operand \ 1st Operand	#word	AX	rp ^{Note}	sfrp	saddrp	!addr16	SP	None
AX	ADDW SUBW CMPW		MOVW XCHW	MOVW	MOVW	MOVW	MOVW	
rp	MOVW	MOVW ^{Note}						INCW, DECW PUSH, POP
sfrp	MOVW	MOVW						
saddrp	MOVW	MOVW						
!addr16		MOVW						
SP	MOVW	MOVW						

Note Only when rp = BC, DE, HL

(3) Bit manipulation instructions

MOV1, AND1, OR1, XOR1, SET1, CLR1, NOT1, BT, BF, BTCLR

2nd Operand \ 1st Operand	A.bit	sfr.bit	saddr.bit	PSW.bit	[HL].bit	CY	\$addr16	None
A.bit						MOV1	BT BF BTCLR	SET1 CLR1
sfr.bit						MOV1	BT BF BTCLR	SET1 CLR1
saddr.bit						MOV1	BT BF BTCLR	SET1 CLR1
PSW.bit						MOV1	BT BF BTCLR	SET1 CLR1
[HL].bit						MOV1	BT BF BTCLR	SET1 CLR1
CY	MOV1 AND1 OR1 XOR1	MOV1 AND1 OR1 XOR1	MOV1 AND1 OR1 XOR1	MOV1 AND1 OR1 XOR1	MOV1 AND1 OR1 XOR1			SET1 CLR1 NOT1

(4) Call instructions/Branch instructions

CALL, CALLF, CALLT, BR, BC, BNC, BZ, BNZ, BT, BF, BTCLR, DBNZ

2nd Operand \ 1st Operand	AX	!addr16	!addr11	[addr5]	\$addr16
Basic instruction	BR	CALL BR	CALLF	CALLT	BR, BC BNC BZ, BNZ
Compound instruction					BT, BF BTCLR DBNZ

(5) Other instructions

ADJBA, ADJBS, BRK, RET, RETI, RETB, SEL, NOP, EI, DI, HALT, STOP

11. ELECTRICAL SPECIFICATIONS

ABSOLUTE MAXIMUM RATINGS (T_A = 25°C)

Parameter	Symbol	Conditions		Rating	Unit
Supply voltage	V _{DD}			-0.3 to +7.0	V
	AV _{REF0}			-0.3 to V _{DD} + 0.3	V
	AV _{REF1}			-0.3 to V _{DD} + 0.3	V
	AV _{SS}			-0.3 to +0.3	V
Input voltage	V _{I1}	P00 to P07, P10 to P17, P20 to P27, P30 to P37, P40 to P47, P50 to P57, P64 to P67, P70 to P72, P80 to P87, P94 to P96, P100 to P103, P120 to P127, P130, P131, X1, X2, XT2, RESET		-0.3 to V _{DD} + 0.3	V
	V _{I2}	P60 to P63, P90 to P93	N-ch open-drain	-0.3 to +16	V
Output voltage	V _O			-0.3 to V _{DD} + 0.3	V
Analog input voltage	V _{AN}	P10 to P17	Analog input pin	AV _{SS} - 0.3 to AV _{REF0} + 0.3	V
High-level output current	I _{OH}	1 pin		-10	mA
		P30 to P37, P56, P57, P60 to P67, P90 to P96, P100 to P103, P120 to P127 total		-15	mA
		P01 to P06, P10 to P17, P20 to P27, P40 to P47, P50 to P55, P70 to P72, P80 to P87, P130, P131 total		-15	mA
Low-level output current	I _{OL} ^{Note}	1 pin	Peak value	30	mA
			RMS	15	mA
		P20 to P27, P40 to P47, P50 to P57, P60 to P63, P80 to P87 total	Peak value	100	mA
			RMS	70	mA
		P01 to P06, P10 to P17, P30 to P37, P64 to P67, P70 to P72, P90 to P96, P100 to P103, P120 to P127, P130, P131 total	Peak value	100	mA
			RMS	70	mA
Operating ambient temperature	T _A			-40 to +85	°C
Storage temperature	T _{stg}			-65 to +150	°C

Note RMS should be calculated as follows: [RMS] = [Peak value] × √duty

Caution Product quality may suffer if the absolute maximum ratings are exceeded for even a single parameter or even momentarily. That is, the absolute maximum ratings are rated values at which the product is on the verge of suffering physical damage, and therefore the product must be used under conditions which ensure that the absolute maximum ratings are not exceeded.

Remark The characteristics of the shared pins are the same as those of the port pins unless otherwise specified.

CAPACITANCE (T_A = 25°C, V_{DD} = V_{SS} = 0 V)

Parameter	Symbol	Conditions		MIN.	TYP.	MAX.	Unit
Input capacitance	C _{IN}	f = 1 MHz, Unmeasured pins returned to 0 V	P01 to P07, P10 to P17, P20 to P27, P30 to P37, P40 to P47, P50 to P57, P64 to P67, P70 to P72, P80 to P87, P94 to P96, P100 to P103, P120 to P127, P130, P131			15	pF
			P60 to P63, P90 to P93			20	pF
Output capacitance	C _{OUT}		P01 to P07, P10 to P17, P20 to P27, P30 to P37, P40 to P47, P50 to P57, P64 to P67, P70 to P72, P80 to P87, P94 to P96, P100 to P103, P120 to P127, P130, P131			15	pF
			P60 to P63, P90 to P93			20	pF
Input/output capacitance	C _{IO}		P01 to P07, P10 to P17, P20 to P27, P30 to P37, P40 to P47, P50 to P57, P64 to P67, P70 to P72, P80 to P87, P94 to P96, P100 to P103, P120 to P127, P130, P131			15	pF
			P60 to P63, P90 to P93			20	pF

Remark The characteristics of the shared pins are the same as those of the port pins unless otherwise specified.

MAIN SYSTEM CLOCK OSCILLATION CIRCUIT CHARACTERISTICS (T_A = -40 to +85°C, V_{DD} = 1.8 to 5.5 V)

Resonator	Recommended Circuit	Parameter	Conditions	MIN.	TYP.	MAX.	Unit
Ceramic resonator		Oscillation frequency (f _x) ^{Note 1}	V _{DD} = Oscillation voltage range	1.0		5.0	MHz
		Oscillation stabilization time ^{Note 2}	After V _{DD} reaches oscillation voltage range MIN.			4	ms
Crystal resonator		Oscillation frequency (f _x) ^{Note 1}		1.0		5.0	MHz
		Oscillation stabilization time ^{Note 2}	V _{DD} = 4.5 to 5.5 V			10	ms
						30	
External clock		X1 input frequency (f _x) ^{Note 1}		1.0		5.0	MHz
		X1 input high/low-level width (t _{xH} , t _{xL})		85		500	ns

Notes 1. Indicates only oscillation circuit characteristics. Refer to **AC CHARACTERISTICS** for instruction execution time.

2. Time required to stabilize oscillation after reset or STOP mode release.

Cautions 1. When using the main system clock oscillation circuit, wiring in the area enclosed with the broken line should be carried out as follows to avoid an adverse effect from wiring capacitance.

- Wiring should be as short as possible.
 - Wiring should not cross other signal lines.
 - Wiring should not be placed close to a varying high current.
 - The potential of the oscillation circuit capacitor ground should always be the same as that of V_{SS}.
 - Do not ground wiring to a ground pattern in which a high current flows.
 - Do not fetch a signal from the oscillation circuit.
2. When the main system clock is stopped and the system is operated by the subsystem clock, the subsystem clock should be switched again to the main system clock after the oscillation stabilization time is secured by the program.

SUBSYSTEM CLOCK OSCILLATION CIRCUIT CHARACTERISTICS (T_A = -40 to +85°C, V_{DD} = 1.8 to 5.5 V)

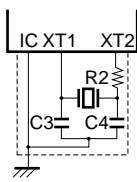
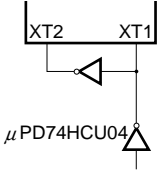
Resonator	Recommended Circuit	Parameter	Conditions	MIN.	TYP.	MAX.	Unit
Crystal resonator		Oscillation frequency (f _{XT}) ^{Note 1}		32	32.768	35	kHz
		Oscillation stabilization time ^{Note 2}	V _{DD} = 4.5 to 5.5 V		1.2	2	s
External clock		XT1 input frequency (f _{XT}) ^{Note 1}		32		100	kHz
		XT1 input high/low-level width (t _{XTH} , t _{XTL})		5		15	μs

Notes 1. Indicates only oscillation circuit characteristics. Refer to **AC CHARACTERISTICS** for instruction execution time.

2. Time required to stabilize oscillation after V_{DD} reaches oscillation voltage range MIN.

Cautions 1. When using the subsystem clock oscillation circuit, wiring in the area enclosed with the broken line should be carried out as follows to avoid an adverse effect from wiring capacitance.

- Wiring should be as short as possible.
- Wiring should not cross other signal lines.
- Wiring should not be placed close to a varying high current.
- The potential of the oscillation circuit capacitor ground should always be the same as that of V_{SS}.
- Do not ground wiring to a ground pattern in which a high current flows.
- Do not fetch a signal from the oscillation circuit.

2. The subsystem clock oscillation circuit is designed to be a circuit with a low amplification level, for low current consumption more prone to misoperation due to noise than that of the main system clock. Therefore, when using the subsystem clock, take special cautions for wiring methods.

DC CHARACTERISTICS (T_A = -40 to +85°C, V_{DD} = 1.8 to 5.5 V)

Parameter	Symbol	Conditions	MIN.	TYP.	MAX.	Unit	
High-level input voltage	V _{IH1}	P10 to P17, P21, P23, P30 to P32, P35 to P37, P40 to P47, P50 to P57, P64 to P67, P71, P80 to P87, P94 to P96, P102, P103, P120 to P127, P130, P131	V _{DD} = 2.7 to 5.5 V	0.7V _{DD}		V _{DD}	V
				0.8V _{DD}		V _{DD}	V
	V _{IH2}	P00 to P06, P20, P22, P24 to P27, P33, P34, P70, P72, P100, P101, RESET	V _{DD} = 2.7 to 5.5 V	0.8V _{DD}		V _{DD}	V
				0.85V _{DD}		V _{DD}	V
	V _{IH3}	P60 to P63, P90 to P93 (N-ch open-drain)	V _{DD} = 2.7 to 5.5 V	0.7V _{DD}		15	V
				0.8V _{DD}		15	V
	V _{IH4}	X1, X2	V _{DD} = 2.7 to 5.5 V	V _{DD} - 0.5		V _{DD}	V
				V _{DD} - 0.2		V _{DD}	V
	V _{IH5}	XT1/P07, XT2	4.5 V ≤ V _{DD} ≤ 5.5 V	0.8V _{DD}		V _{DD}	V
			2.7 V ≤ V _{DD} < 4.5 V	0.9V _{DD}		V _{DD}	V
			Note	0.9V _{DD}		V _{DD}	V
	Low-level input voltage	V _{IL1}	P10 to P17, P21, P23, P30 to P32, P35 to P37, P40 to P47, P50 to P57, P64 to P67, P71, P80 to P87, P94 to P96, P102, P103, P120 to P127, P130, P131	V _{DD} = 2.7 to 5.5 V	0		0.3V _{DD}
				0		0.2V _{DD}	V
V _{IL2}		P00 to P06, P20, P22, P24 to P27, P33, P34, P70, P72, P100, P101, RESET	V _{DD} = 2.7 to 5.5 V	0		0.2V _{DD}	V
				0		0.15V _{DD}	V
V _{IL3}		P60 to P63, P90 to P93 (N-ch open-drain)	4.5 V ≤ V _{DD} ≤ 5.5 V	0		0.3V _{DD}	V
			2.7 V ≤ V _{DD} < 4.5 V	0		0.2V _{DD}	V
				0		0.1V _{DD}	V
V _{IL4}		X1, X2	V _{DD} = 2.7 to 5.5 V	0		0.4	V
				0		0.2	V
V _{IL5}		XT1/P07, XT2	4.5 V ≤ V _{DD} ≤ 5.5 V	0		0.2V _{DD}	V
			2.7 V ≤ V _{DD} < 4.5 V	0		0.1V _{DD}	V
			Note	0		0.1V _{DD}	V
High-level output voltage	V _{OH}	V _{DD} = 4.5 to 5.5 V, I _{OH} = -1 mA	V _{DD} - 1.0			V	
		I _{OH} = -100 μA	V _{DD} - 0.5			V	
Low-level output voltage	V _{OL1}	P50 to P57, P60 to P63, P90 to P93	V _{DD} = 4.5 to 5.5 V, I _{OL} = 1.6 mA		0.4	2.0	V
		P01 to P06, P10 to P17, P20 to P27, P30 to P37, P40 to P47, P64 to P67, P70 to P72, P80 to P87, P94 to P96, P100 to P103, P120 to P127, P130, P131				0.4	V
	V _{OL2}	SB0, SB1, SCK0	V _{DD} = 4.5 to 5.5 V, open-drain, at pulled-up (R = 1 kΩ)			0.2V _{DD}	V
	V _{OL3}	I _{OL} = 400 μA				0.5	V

Note For use as P07, use an inverter to input the inverted phase of P07 to the XT2 pin.

Remark The characteristics of the shared pins are the same as those of the port pins unless otherwise specified.

DC CHARACTERISTICS (T_A = -40 to +85°C, V_{DD} = 1.8 to 5.5 V)

Parameter	Symbol	Conditions		MIN.	TYP.	MAX.	Unit
High-level input leakage current	I _{LIH1}	V _{IN} = V _{DD}	P00 to P06, P10 to P17, P20 to P27, P30 to P37, P40 to P47, P50 to P57, P64 to P67, P70 to P72, P80 to P87, P94 to P96, P100 to P103, P120 to P127, P130, P131, $\overline{\text{RESET}}$			3	μA
	I _{LIH2}		X1, X2, XT1/P07, XT2			20	μA
	I _{LIH3}	V _{IN} = 15 V	P60 to P63, P90 to P93			80	μA
Low-level input leakage current	I _{LIL1}	V _{IN} = 0 V	P00 to P06, P10 to P17, P20 to P27, P30 to P37, P40 to P47, P50 to P57, P64 to P67, P70 to P72, P80 to P87, P94 to P96, P100 to P103, $\overline{\text{RESET}}$ P120 to P127, P130, P131, $\overline{\text{RESET}}$			-3	μA
	I _{LIL2}		X1, X2, XT1/P07, XT2			-20	μA
	I _{LIL3}		P60 to P63, P90 to P93			-3 ^{Note 1}	μA
High-level output leakage current	I _{LOH}	V _{OUT} = V _{DD}				3	μA
Low-level output leakage current	I _{LOL}	V _{OUT} = 0 V				-3	μA
Mask option pull-up resistor	R ₁	V _{IN} = 0 V, P60 to P63, P90 to P93		20	40	90	kΩ
Software pull-up resistor ^{Note 2}	R ₂	V _{IN} = 0 V, P10 to P17, P20 to P27, P30 to P37, P40 to P47, P50 to P57, P64 to P67, P70 to P72, P80 to P87, P94 to P96, P100 to P103, P120 to P127, P130, P131	4.5 V ≤ V _{DD} ≤ 5.5 V	15	33	90	kΩ
			2.7 V ≤ V _{DD} < 4.5 V	20		500	kΩ

Notes 1. When the pull-up resistors are not connected to P60 to P63 and P90 to P93 (specified by mask option), a low-level input leakage current of -200 μA (MAX.) flows only for 1.5 clocks (without wait) after a read instruction has been executed to port 6 (P6), port mode register 6 (PM6), port 9 (P9), or port mode register 9 (PM9).

The current is -3 μA (MAX.) when other than 1.5 clocks after the read instruction has been executed.

2. A software pull-up resistor can be used only in the range of V_{DD} = 2.7 to 5.5 V.

Remark The characteristics of the shared pins are the same as those of the port pins unless otherwise specified.

DC CHARACTERISTICS (T_A = -40 to +85°C, V_{DD} = 1.8 to 5.5 V)

Parameter	Symbol	Conditions	MIN.	TYP.	MAX.	Unit	
Power supply current ^{Note 1}	I _{DD1}	5.0 MHz crystal oscillation operating mode (f _{xx} = 2.5 MHz) ^{Note 2}	V _{DD} = 5.0 V ± 10 % ^{Note 5}		3.4	13.5	mA
			V _{DD} = 3.0 V ± 10 % ^{Note 6}		0.7	2.1	mA
			V _{DD} = 2.0 V ± 10 % ^{Note 6}		0.4	1.2	mA
		5.0 MHz crystal oscillation operating mode (f _{xx} = 5.0 MHz) ^{Note 3}	V _{DD} = 5.0 V ± 10 % ^{Note 5}		5.6	24.0	mA
			V _{DD} = 3.0 V ± 10 % ^{Note 6}		0.9	2.7	mA
			V _{DD} = 2.0 V ± 10 %				
	I _{DD2}	5.0 MHz crystal oscillation HALT mode (f _{xx} = 2.5 MHz) ^{Note 2}	V _{DD} = 5.0 V ± 10 %		1.4	4.2	mA
			V _{DD} = 3.0 V ± 10 %		0.6	1.5	mA
			V _{DD} = 2.0 V ± 10 %		270	840	μA
		5.0 MHz crystal oscillation HALT mode (f _{xx} = 5.0 MHz) ^{Note 3}	V _{DD} = 5.0 V ± 10 %		1.7	4.8	mA
			V _{DD} = 3.0 V ± 10 %		0.68	1.95	mA
			V _{DD} = 2.0 V ± 10 %				
	I _{DD3}	32.768 kHz crystal oscillation operating mode ^{Note 4}	V _{DD} = 5.0 V ± 10 %		46	120	μA
			V _{DD} = 3.0 V ± 10 %		26	64	μA
			V _{DD} = 2.0 V ± 10 %		18	48	μA
I _{DD4}	32.768 kHz crystal oscillation HALT mode ^{Note 4}	V _{DD} = 5.0 V ± 10 %		17	55	μA	
		V _{DD} = 3.0 V ± 10 %		6	15	μA	
		V _{DD} = 2.0 V ± 10 %		2.5	12.5	μA	
I _{DD5}	XT1 = V _{DD} STOP mode When feedback resistor is used	V _{DD} = 5.0 V ± 10 %		1.7	30	μA	
		V _{DD} = 3.0 V ± 10 %		0.7	10	μA	
		V _{DD} = 2.0 V ± 10 %		0.3	10	μA	
I _{DD6}	XT1 = V _{DD} STOP mode When feedback resistor is unused	V _{DD} = 5.0 V ± 10 %		0.01	30	μA	
		V _{DD} = 3.0 V ± 10 %		0.01	10	μA	
		V _{DD} = 2.0 V ± 10 %		0.01	10	μA	

- Notes**
1. The AV_{REF0}, AV_{REF1}, AV_{DD} currents and port current (including a current flowing in the on-chip pull-up resistor) are not included.
 2. Operation with f_{xx} = f_x/2 (when oscillation mode select register (OSMS) is set to 00H)
 3. Operation with f_{xx} = f_x (when oscillation mode select register (OSMS) is set to 01H)
 4. When the main system clock is halted
 5. Operating in high-speed mode (when the processor clock control register (PCC) is set to 00H).
 6. Operating in low-speed mode (when the processor clock control register (PCC) is set to 04H).

- Remarks**
1. The characteristics of the shared pins are the same as those of the port pins unless otherwise specified.
 2. f_{xx}: Main system clock frequency (f_x or f_x/2)
 3. f_x: Main system clock oscillation frequency

AC CHARACTERISTICS

(1) Basic Operation (T_A = -40 to +85°C, V_{DD} = 1.8 to 5.5 V)

Parameter	Symbol	Conditions		MIN.	TYP.	MAX.	Unit	
Cycle time (Min. instruction execution time)	T _{CY}	Operating on main system clock	f _{xx} = f _x /2 ^{Note 1}	V _{DD} = 2.7 to 5.5 V	0.8		64	μs
					2.0		64	μs
			f _{xx} = f _x ^{Note 2}	3.5 V ≤ V _{DD} ≤ 5.5 V	0.4		32	μs
				2.7 V ≤ V _{DD} < 3.5 V	0.8		32	μs
		Operating on subsystem clock	40	122	125	μs		
TI00 input high/ low-level width	t _{TIH00} , t _{TIL00}	3.5 V ≤ V _{DD} ≤ 5.5 V		2/f _{sam} + 0.1 ^{Note 3}			μs	
		2.7 V ≤ V _{DD} < 3.5 V		2/f _{sam} + 0.2 ^{Note 3}			μs	
				2/f _{sam} + 0.5 ^{Note 3}			μs	
TI01 input high/ low-level width	t _{TIH01} , t _{TIL01}	V _{DD} = 2.7 to 5.5 V		10			μs	
				20			μs	
TI1, TI2, TI5, TI6 input frequency	f _{TI1}	V _{DD} = 4.5 to 5.5 V		0		4	MHz	
				0		275	kHz	
TI1, TI2, TI5, TI6 input high/ low-level width	t _{TIH1} , t _{TIL1}	V _{DD} = 4.5 to 5.5 V		100			ns	
				1.8			μs	
Interrupt input high/low-level width	t _{INTH} , t _{INTL}	INTP0	3.5 V ≤ V _{DD} ≤ 5.5 V	2/f _{sam} + 0.1 ^{Note 3}			μs	
			2.7 V ≤ V _{DD} < 3.5 V	2/f _{sam} + 0.2 ^{Note 3}			μs	
				2/f _{sam} + 0.5 ^{Note 3}			μs	
		INTP1 to INTP6, KR0 to KR7	V _{DD} = 2.7 to 5.5 V		10			μs
					20			μs
RESET low- level width	t _{RSL}	V _{DD} = 2.7 to 5.5 V		10			μs	
				20			μs	

- Notes**
1. When oscillation mode select register (OSMS) is set to 00H
 2. When oscillation mode select register (OSMS) is set to 01H
 3. In combination with bits 0 (SCS0) and 1 (SCS1) of sampling clock select register (SCS), selection of f_{sam} is possible between f_{xx}/2^N, f_{xx}/32, f_{xx}/64 and f_{xx}/128 (when N = 0 to 4).

Remark f_{xx} : Main system clock frequency (f_x or f_x/2)
 f_x : Main system clock oscillation frequency

T_{CY} vs V_{DD} (At f_{XX} = f_X/2 main system clock operation)

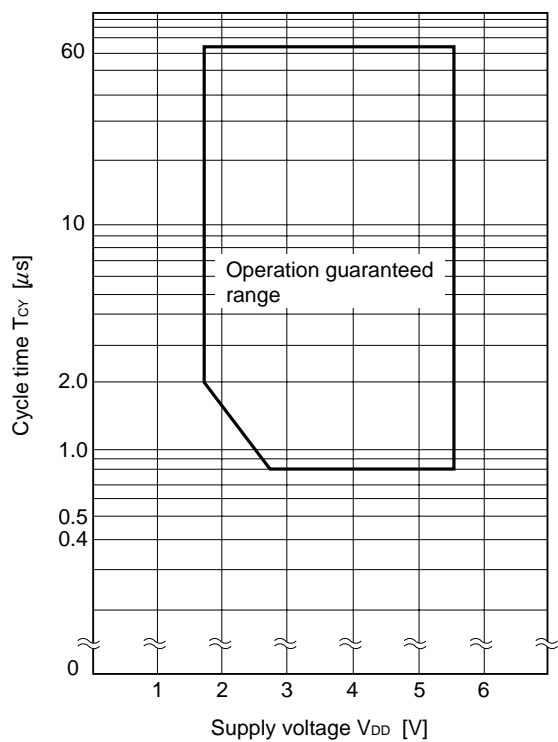

T_{CY} vs V_{DD} (At f_{XX} = f_X main system clock operation)

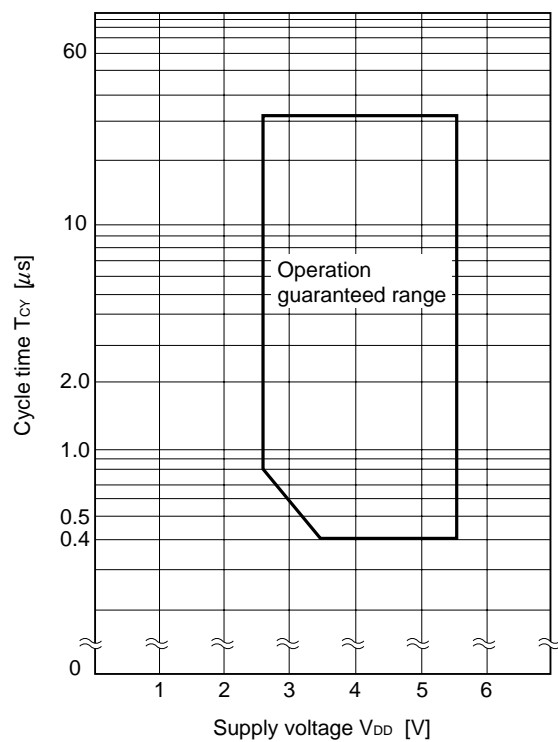

(2) READ/WRITE OPERATION

(a) When MCS = 1, PCC2 to PCC0 = 000B ($T_A = -40$ to $+85^\circ\text{C}$, $V_{DD} = 4.5$ to 5.5 V)

Parameter	Symbol	Conditions	MIN.	MAX.	Unit
ASTB high-level width	t_{ASTH}		$0.85t_{CY} - 50$		ns
Address setup time	t_{ADS}		$0.85t_{CY} - 50$		ns
Address hold time	t_{ADH}		50		ns
Data input time from address	t_{ADD1}			$(2.85 + 2n)t_{CY} - 80$	ns
	t_{ADD2}			$(4 + 2n)t_{CY} - 100$	ns
Data input time from $\overline{RD}\downarrow$	t_{RDD1}			$(2 + 2n)t_{CY} - 100$	ns
	t_{RDD2}			$(2.85 + 2n)t_{CY} - 100$	ns
Read data hold time	t_{RDH}		0		ns
\overline{RD} low-level width	t_{RDL1}		$(2 + 2n)t_{CY} - 60$		ns
	t_{RDL2}		$(2.85 + 2n)t_{CY} - 60$		ns
$\overline{WAIT}\downarrow$ input time from $\overline{RD}\downarrow$	t_{RDWT1}			$0.85t_{CY} - 50$	ns
	t_{RDWT2}			$2t_{CY} - 60$	ns
$\overline{WAIT}\downarrow$ input time from $\overline{WR}\downarrow$	t_{WRWT}			$2t_{CY} - 60$	ns
\overline{WAIT} low-level width	t_{WTL}		$(1.15 + 2n)t_{CY}$	$(2 + 2n)t_{CY}$	ns
Write data setup time	t_{WDS}		$(2.85 + 2n)t_{CY} - 100$		ns
Write data hold time	t_{WDH}	Load resistance ≥ 5 k Ω	20		ns
\overline{WR} low-level width	t_{WRL1}		$(2.85 + 2n)t_{CY} - 60$		ns
$\overline{RD}\downarrow$ delay time from $\overline{ASTB}\downarrow$	t_{ASTRD}		25		ns
$\overline{WR}\downarrow$ delay time from $\overline{ASTB}\downarrow$	t_{ASTWR}		$0.85t_{CY} + 20$		ns
ASTB \uparrow delay time from $\overline{RD}\uparrow$ at external fetch	t_{RDAST}		$0.85t_{CY} - 10$	$1.15t_{CY} + 20$	ns
Address hold time from $\overline{RD}\uparrow$ at external fetch	t_{RDADH}		$0.85t_{CY} - 50$	$1.15t_{CY} + 50$	ns
Write data output time from $\overline{RD}\uparrow$	t_{RDWD}		40		ns
Write data output time from $\overline{WR}\downarrow$	t_{WRWD}		0	50	ns
Address hold time from $\overline{WR}\uparrow$	t_{WRADH}		$0.85t_{CY} - 20$	$1.15t_{CY} + 40$	ns
$\overline{RD}\uparrow$ delay time from $\overline{WAIT}\uparrow$	t_{WTRD}		$1.15t_{CY} + 40$	$3.15t_{CY} + 40$	ns
$\overline{WR}\uparrow$ delay time from $\overline{WAIT}\uparrow$	t_{WTWR}		$1.15t_{CY} + 30$	$3.15t_{CY} + 30$	ns

- Remarks**
1. MCS : Oscillation mode select register (OSMS) bit 0
 2. PCC2 to PCC0 : Processor clock control register (PCC) bit 2 to bit 0
 3. $t_{CY} = T_{CY}/4$
 4. n indicates the number of waits.

(b) When except MCS = 1, PCC2 to PCC0 = 000B (T_A = -40 to +85°C, V_{DD} = 2.7 to 5.5 V)

Parameter	Symbol	Conditions	MIN.	MAX.	Unit
ASTB high-level width	t _{ASTH}		t _{CY} - 80		ns
Address setup time	t _{ADS}		t _{CY} - 80		ns
Address hold time	t _{ADH}		0.4t _{CY} - 10		ns
Data input time from address	t _{ADD1}			(3 + 2n)t _{CY} - 160	ns
	t _{ADD2}			(4 + 2n)t _{CY} - 200	ns
Data input time from $\overline{RD}\downarrow$	t _{RDD1}			(1.4 + 2n)t _{CY} - 70	ns
	t _{RDD2}			(2.4 + 2n)t _{CY} - 70	ns
Read data hold time	t _{RDH}		0		ns
\overline{RD} low-level width	t _{RDL1}		(1.4 + 2n)t _{CY} - 20		ns
	t _{RDL2}		(2.4 + 2n)t _{CY} - 20		ns
$\overline{WAIT}\downarrow$ input time from $\overline{RD}\downarrow$	t _{RDWT1}			t _{CY} - 100	ns
	t _{RDWT2}			2t _{CY} - 100	ns
$\overline{WAIT}\downarrow$ input time from $\overline{WR}\downarrow$	t _{WRWT}			2t _{CY} - 100	ns
\overline{WAIT} low-level width	t _{WTL}		(1 + 2n)t _{CY}	(2 + 2n)t _{CY}	ns
Write data setup time	t _{WDS}		(2.4 + 2n)t _{CY} - 60		ns
Write data hold time	t _{WDH}	Load resistance ≥ 5 kΩ	20		ns
\overline{WR} low-level width	t _{WRL}		(2.4 + 2n)t _{CY} - 20		ns
$\overline{RD}\downarrow$ delay time from $\overline{ASTB}\downarrow$	t _{ASTRD}		0.4t _{CY} - 30		ns
$\overline{WR}\downarrow$ delay time from $\overline{ASTB}\downarrow$	t _{ASTWR}		1.4t _{CY} - 30		ns
ASTB \uparrow delay time from $\overline{RD}\uparrow$ at external fetch	t _{RDAST}		t _{CY} - 10	t _{CY} + 20	ns
Address hold time from $\overline{RD}\uparrow$ at external fetch	t _{RDADH}		t _{CY} - 80	t _{CY} + 50	ns
Write data output time from $\overline{RD}\uparrow$	t _{RDWD}		0.4t _{CY} - 30		ns
Write data output time from $\overline{WR}\downarrow$	t _{WRWD}		0	60	ns
Address hold time from $\overline{WR}\uparrow$	t _{WRADH}		t _{CY} - 60	t _{CY} + 60	ns
$\overline{RD}\uparrow$ delay time from $\overline{WAIT}\uparrow$	t _{WTRD}		0.6t _{CY} + 180	2.6t _{CY} + 180	ns
$\overline{WR}\uparrow$ delay time from $\overline{WAIT}\uparrow$	t _{WTWR}		0.6t _{CY} + 120	2.6t _{CY} + 120	ns

- Remarks**
1. MCS : Oscillation mode select register (OSMS) bit 0
 2. PCC2 to PCC0 : Processor clock control register (PCC) bit 2 to bit 0
 3. t_{CY} = T_{CY}/4
 4. n indicates the number of waits.

(3) SERIAL INTERFACE (T_A = -40 to +85°C, V_{DD} = 1.8 to 5.5 V)

(a) Serial Interface Channel 0

(i) 3-wire serial I/O mode ($\overline{\text{SCK0}}$... Internal clock output)

Parameter	Symbol	Conditions	MIN.	TYP.	MAX.	Unit
$\overline{\text{SCK0}}$ cycle time	t _{KCY1}	4.5 V ≤ V _{DD} ≤ 5.5 V	800			ns
		2.7 V ≤ V _{DD} < 4.5 V	1600			ns
		2.0 V ≤ V _{DD} < 2.7 V	3200			ns
			4800			ns
$\overline{\text{SCK0}}$ high/low-level width	t _{KH1} , t _{KL1}	V _{DD} = 4.5 to 5.5 V	t _{KCY1} /2 - 50			ns
			t _{KCY1} /2 - 100			ns
SI0 setup time (to $\overline{\text{SCK0}}\uparrow$)	t _{SIK1}	4.5 V ≤ V _{DD} ≤ 5.5 V	100			ns
		2.7 V ≤ V _{DD} < 4.5 V	150			ns
		2.0 V ≤ V _{DD} < 2.7 V	300			ns
			400			ns
SI0 hold time (from $\overline{\text{SCK0}}\uparrow$)	t _{KSI1}		400			ns
SO0 output delay time from $\overline{\text{SCK0}}\downarrow$	t _{KSO1}	C = 100 pF ^{Note}			300	ns

Note C is the load capacitance of $\overline{\text{SCK0}}$ and SO0 output lines.

(ii) 3-wire serial I/O mode ($\overline{\text{SCK0}}$... External clock input)

Parameter	Symbol	Conditions	MIN.	TYP.	MAX.	Unit
$\overline{\text{SCK0}}$ cycle time	t _{KCY2}	4.5 V ≤ V _{DD} ≤ 5.5 V	800			ns
		2.7 V ≤ V _{DD} < 4.5 V	1600			ns
		2.0 V ≤ V _{DD} < 2.7 V	3200			ns
			4800			ns
$\overline{\text{SCK0}}$ high/low-level width	t _{KH2} , t _{KL2}	4.5 V ≤ V _{DD} ≤ 5.5 V	400			ns
		2.7 V ≤ V _{DD} < 4.5 V	800			ns
		2.0 V ≤ V _{DD} < 2.7 V	1600			ns
			2400			ns
SI0 setup time (to $\overline{\text{SCK0}}\uparrow$)	t _{SIK2}	V _{DD} = 2.0 to 5.5 V	100			ns
			150			ns
SI0 hold time (from $\overline{\text{SCK0}}\uparrow$)	t _{KSI2}		400			ns
SO0 output delay time from $\overline{\text{SCK0}}\downarrow$	t _{KSO2}	C = 100 pF ^{Note} V _{DD} = 2.0 to 5.5 V			300	ns
					500	ns
$\overline{\text{SCK0}}$ rise/fall time	t _{R2} , t _{F2}	When using external device expansion function			160	ns
		When not using external device expansion function			1000	ns

Note C is the load capacitance of SO0 output line.

(iii) SBI mode ($\overline{\text{SCK0}}$... Internal clock output)

Parameter	Symbol	Conditions	MIN.	TYP.	MAX.	Unit
$\overline{\text{SCK0}}$ cycle time	t_{KCY3}	$4.5 \text{ V} \leq V_{\text{DD}} \leq 5.5 \text{ V}$	800			ns
		$2.0 \text{ V} \leq V_{\text{DD}} < 4.5 \text{ V}$	3200			ns
			4800			ns
$\overline{\text{SCK0}}$ high/low-level width	$t_{\text{KH3}}, t_{\text{KL3}}$	$V_{\text{DD}} = 4.5 \text{ to } 5.5 \text{ V}$	$t_{\text{KCY3}}/2 - 50$			ns
			$t_{\text{KCY3}}/2 - 150$			ns
SB0, SB1 setup time (to $\overline{\text{SCK0}}\uparrow$)	t_{SIK3}	$4.5 \text{ V} \leq V_{\text{DD}} \leq 5.5 \text{ V}$	100			ns
		$2.0 \text{ V} \leq V_{\text{DD}} < 4.5 \text{ V}$	300			ns
			400			ns
SB0, SB1 hold time (from $\overline{\text{SCK0}}\uparrow$)	t_{KSI3}		$t_{\text{KCY3}}/2$			ns
SB0, SB1 output delay time from $\overline{\text{SCK0}}\downarrow$	t_{KSO3}	R = 1 kΩ, C = 100 pF ^{Note}	$V_{\text{DD}} = 4.5 \text{ to } 5.5 \text{ V}$	0	250	ns
				0	1000	ns
SB0, SB1↓ from $\overline{\text{SCK0}}\uparrow$	t_{KSB}		t_{KCY3}			ns
$\overline{\text{SCK0}}\downarrow$ from SB0, SB1↓	t_{SBK}	$2.0 \text{ V} \leq V_{\text{DD}} \leq 5.5 \text{ V}$	t_{KCY3}			ns
SB0, SB1 high-level width	t_{SBH}	$2.0 \text{ V} \leq V_{\text{DD}} \leq 5.5 \text{ V}$	t_{KCY3}			ns
SB0, SB1 low-level width	t_{SBL}	$2.0 \text{ V} \leq V_{\text{DD}} \leq 5.5 \text{ V}$	t_{KCY3}			ns

Note R and C are the load resistance and load capacitance of the $\overline{\text{SCK0}}$ and SB0, SB1 output lines.

(iv) SBI mode ($\overline{\text{SCK0}}$... External clock input)

Parameter	Symbol	Conditions	MIN.	TYP.	MAX.	Unit
$\overline{\text{SCK0}}$ cycle time	t_{KCY4}	$4.5 \text{ V} \leq V_{\text{DD}} \leq 5.5 \text{ V}$	800			ns
		$2.0 \text{ V} \leq V_{\text{DD}} < 4.5 \text{ V}$	3200			ns
			4800			ns
$\overline{\text{SCK0}}$ high/low-level width	$t_{\text{KH4}}, t_{\text{KL4}}$	$4.5 \text{ V} \leq V_{\text{DD}} \leq 5.5 \text{ V}$	400			ns
		$2.0 \text{ V} \leq V_{\text{DD}} < 4.5 \text{ V}$	1600			ns
			2400			ns
SB0, SB1 setup time (to $\overline{\text{SCK0}}\uparrow$)	t_{SIK4}	$4.5 \text{ V} \leq V_{\text{DD}} \leq 5.5 \text{ V}$	100			ns
		$2.0 \text{ V} \leq V_{\text{DD}} < 4.5 \text{ V}$	300			ns
			400			ns
SB0, SB1 hold time (from $\overline{\text{SCK0}}\uparrow$)	t_{KSI4}		$t_{\text{KCY4}}/2$			ns
SB0, SB1 output delay time from $\overline{\text{SCK0}}\downarrow$	t_{KSO4}	R = 1 kΩ, C = 100 pF ^{Note}	$V_{\text{DD}} = 4.5 \text{ to } 5.5 \text{ V}$	0	300	ns
				0	1000	ns
SB0, SB1↓ from $\overline{\text{SCK0}}\uparrow$	t_{KSB}		t_{KCY4}			ns
$\overline{\text{SCK0}}\downarrow$ from SB0, SB1↓	t_{SBK}	$2.0 \text{ V} \leq V_{\text{DD}} \leq 5.5 \text{ V}$	t_{KCY4}			ns
SB0, SB1 high-level width	t_{SBH}	$2.0 \text{ V} \leq V_{\text{DD}} \leq 5.5 \text{ V}$	t_{KCY4}			ns
SB0, SB1 low-level width	t_{SBL}	$2.0 \text{ V} \leq V_{\text{DD}} \leq 5.5 \text{ V}$	t_{KCY4}			ns
$\overline{\text{SCK0}}$ rise/fall time	$t_{\text{R4}}, t_{\text{F4}}$	When using external device expansion function			160	ns
		When not using external device expansion function			1000	ns

Note R and C are the load resistance and load capacitance of the SB0, SB1 output line.

(v) 2-wire serial I/O mode ($\overline{\text{SCK0}}$... Internal clock output)

Parameter	Symbol	Conditions	MIN.	TYP.	MAX.	Unit	
$\overline{\text{SCK0}}$ cycle time	t_{KCY5}	R = 1 kΩ, C = 100 pF ^{Note}	2.7 V ≤ V _{DD} ≤ 5.5 V	1600			ns
			2.0 V ≤ V _{DD} < 2.7 V	3200			ns
				4800			ns
$\overline{\text{SCK0}}$ high-level width	t_{KH5}	V _{DD} = 2.7 to 5.5 V	$t_{\text{KCY5}}/2 - 160$			ns	
			$t_{\text{KCY5}}/2 - 190$			ns	
$\overline{\text{SCK0}}$ low-level width	t_{KL5}	V _{DD} = 4.5 to 5.5 V	$t_{\text{KCY5}}/2 - 50$			ns	
			$t_{\text{KCY5}}/2 - 100$			ns	
SB0, SB1 setup time (to $\overline{\text{SCK0}}\uparrow$)	t_{SIK5}	4.5 V ≤ V _{DD} ≤ 5.5 V	300			ns	
			2.7 V ≤ V _{DD} < 4.5 V	350			ns
			2.0 V ≤ V _{DD} < 2.7 V	400			ns
SB0, SB1 hold time (from $\overline{\text{SCK0}}\uparrow$)	t_{SH5}		500			ns	
			600			ns	
SB0, SB1 output delay time from $\overline{\text{SCK0}}\downarrow$	t_{KSO5}		0		300	ns	

Note R and C are the load resistance and load capacitance of the $\overline{\text{SCK0}}$ and SB0, SB1 output lines.

(vi) 2-wire serial I/O mode ($\overline{\text{SCK0}}$... External clock input)

Parameter	Symbol	Conditions	MIN.	TYP.	MAX.	Unit
$\overline{\text{SCK0}}$ cycle time	t_{KCY6}	2.7 V ≤ V _{DD} ≤ 5.5 V	1600			ns
		2.0 V ≤ V _{DD} < 2.7 V	3200			ns
			4800			ns
$\overline{\text{SCK0}}$ high-level width	t_{KH6}	2.7 V ≤ V _{DD} ≤ 5.5 V	650			ns
		2.0 V ≤ V _{DD} < 2.7 V	1300			ns
			2100			ns
$\overline{\text{SCK0}}$ low-level width	t_{KL6}	2.7 V ≤ V _{DD} ≤ 5.5 V	800			ns
		2.0 V ≤ V _{DD} < 2.7 V	1600			ns
			2400			ns
SB0, SB1 setup time (to $\overline{\text{SCK0}}\uparrow$)	t_{SIK6}	V _{DD} = 2.0 to 5.5 V	100			ns
			150			ns
SB0, SB1 hold time (from $\overline{\text{SCK0}}\uparrow$)	t_{SH6}		$t_{\text{KCY6}}/2$			ns
SB0, SB1 output delay time from $\overline{\text{SCK0}}\downarrow$	t_{KSO6}	R = 1 kΩ, C = 100 pF ^{Note}	4.5 V ≤ V _{DD} ≤ 5.5 V	0	300	ns
			2.0 V ≤ V _{DD} < 4.5 V	0	500	ns
					800	ns
$\overline{\text{SCK0}}$ rise/fall time	$t_{\text{R6}}, t_{\text{F6}}$	When using external device expansion function			160	ns
		When not using external device expansion function			1000	ns

Note R and C are the load resistance and load capacitance of the SB0, SB1 output line.

(b) Serial Interface Channel 1

(i) 3-wire serial I/O mode (SCK1... Internal clock output)

Parameter	Symbol	Conditions	MIN.	TYP.	MAX.	Unit
SCK1 cycle time	t _{KCY7}	4.5 V ≤ V _{DD} ≤ 5.5 V	800			ns
		2.7 V ≤ V _{DD} < 4.5 V	1600			ns
		2.0 V ≤ V _{DD} < 2.7 V	3200			ns
			4800			ns
SCK1 high/low-level width	t _{KH7} , t _{KL7}	V _{DD} = 4.5 to 5.5 V	t _{KCY7} /2 - 50			ns
			t _{KCY7} /2 - 100			ns
SI1 setup time (to SCK1↑)	t _{SIK7}	4.5 V ≤ V _{DD} ≤ 5.5 V	100			ns
		2.7 V ≤ V _{DD} < 4.5 V	150			ns
		2.0 V ≤ V _{DD} < 2.7 V	300			ns
			400			ns
SI1 hold time (from SCK1↑)	t _{KSI7}		400			ns
SO1 output delay time from SCK1↓	t _{KSO7}	C = 100 pF ^{Note}			300	ns

Note C is the load capacitance of SCK1 and SO1 output lines.

(ii) 3-wire serial I/O mode (SCK1... External clock input)

Parameter	Symbol	Conditions	MIN.	TYP.	MAX.	Unit
SCK1 cycle time	t _{KCY8}	4.5 V ≤ V _{DD} ≤ 5.5 V	800			ns
		2.7 V ≤ V _{DD} < 4.5 V	1600			ns
		2.0 V ≤ V _{DD} < 2.7 V	3200			ns
			4800			ns
SCK1 high/low-level width	t _{KH8} , t _{KL8}	4.5 V ≤ V _{DD} ≤ 5.5 V	400			ns
		2.7 V ≤ V _{DD} < 4.5 V	800			ns
		2.0 V ≤ V _{DD} < 2.7 V	1600			ns
			2400			ns
SI1 setup time (to SCK1↑)	t _{SIK8}	V _{DD} = 2.0 to 5.5 V	100			ns
			150			ns
SI1 hold time (from SCK1↑)	t _{KSI8}		400			ns
SO1 output delay time from SCK1↓	t _{KSO8}	C = 100 pF ^{Note} V _{DD} = 2.0 to 5.5 V			300	ns
					500	ns
SCK1 rise/fall time	t _{RS} , t _{FS}	When using external device expansion function			160	ns
		When not using external device expansion function			1000	ns

Note C is the load capacitance of SO1 output line.

(iii) 3-wire serial I/O mode with automatic transmit/receive function ($\overline{\text{SCK1}}$... Internal clock output)

Parameter	Symbol	Conditions	MIN.	TYP.	MAX.	Unit
$\overline{\text{SCK1}}$ cycle time	t_{KCY9}	$4.5 \text{ V} \leq V_{\text{DD}} \leq 5.5 \text{ V}$	800			ns
		$2.7 \text{ V} \leq V_{\text{DD}} < 4.5 \text{ V}$	1600			ns
		$2.0 \text{ V} \leq V_{\text{DD}} < 2.7 \text{ V}$	3200			ns
			4800			ns
$\overline{\text{SCK1}}$ high/low-level width	$t_{\text{KH9}}, t_{\text{KL9}}$	$V_{\text{DD}} = 4.5 \text{ to } 5.5 \text{ V}$	$t_{\text{KCY9}}/2 - 50$			ns
			$t_{\text{KCY9}}/2 - 100$			ns
S11 setup time (to $\overline{\text{SCK1}}\uparrow$)	t_{SIK9}	$4.5 \text{ V} \leq V_{\text{DD}} \leq 5.5 \text{ V}$	100			ns
		$2.7 \text{ V} \leq V_{\text{DD}} < 4.5 \text{ V}$	150			ns
		$2.0 \text{ V} \leq V_{\text{DD}} < 2.7 \text{ V}$	300			ns
			400			ns
S11 hold time (from $\overline{\text{SCK1}}\uparrow$)	t_{KS19}		400			ns
SO1 output delay time from $\overline{\text{SCK1}}\downarrow$	t_{KSO9}	$C = 100 \text{ pF}$ ^{Note}			300	ns
$\text{STB}\uparrow$ from $\overline{\text{SCK1}}\uparrow$	t_{SBD}		$t_{\text{KCY9}}/2 - 100$		$t_{\text{KCY9}}/2 + 100$	ns
Strobe signal high-level width	t_{SBW}	$2.7 \text{ V} \leq V_{\text{DD}} \leq 5.5 \text{ V}$	$t_{\text{KCY9}} - 30$		$t_{\text{KCY9}} + 30$	ns
		$2.0 \text{ V} \leq V_{\text{DD}} < 2.7 \text{ V}$	$t_{\text{KCY9}} - 60$		$t_{\text{KCY9}} + 60$	ns
			$t_{\text{KCY9}} - 90$		$t_{\text{KCY9}} + 90$	ns
Busy signal setup time (to busy signal detection timing)	t_{BYS}		100			ns
Busy signal hold time (from busy signal detection timing)	t_{BYH}	$4.5 \text{ V} \leq V_{\text{DD}} \leq 5.5 \text{ V}$	100			ns
		$2.7 \text{ V} \leq V_{\text{DD}} < 4.5 \text{ V}$	150			ns
		$2.0 \text{ V} \leq V_{\text{DD}} < 2.7 \text{ V}$	200			ns
			300			ns
$\overline{\text{SCK1}}\downarrow$ from busy inactive	t_{SPS}				$2t_{\text{KCY9}}$	ns

Note C is the load capacitance of $\overline{\text{SCK1}}$ and SO1 output lines.

(iv) 3-wire serial I/O mode with automatic transmit/receive function ($\overline{\text{SCK1}}$... External clock input)

Parameter	Symbol	Conditions	MIN.	TYP.	MAX.	Unit
$\overline{\text{SCK1}}$ cycle time	t_{KCY10}	$4.5 \text{ V} \leq V_{\text{DD}} \leq 5.5 \text{ V}$	800			ns
		$2.7 \text{ V} \leq V_{\text{DD}} < 4.5 \text{ V}$	1600			ns
		$2.0 \text{ V} \leq V_{\text{DD}} < 2.7 \text{ V}$	3200			ns
			4800			ns
$\overline{\text{SCK1}}$ high/low-level width	$t_{\text{KH10}}, t_{\text{KL10}}$	$4.5 \text{ V} \leq V_{\text{DD}} \leq 5.5 \text{ V}$	400			ns
		$2.7 \text{ V} \leq V_{\text{DD}} < 4.5 \text{ V}$	800			ns
		$2.0 \text{ V} \leq V_{\text{DD}} < 2.7 \text{ V}$	1600			ns
			2400			ns
SI1 setup time (to $\overline{\text{SCK1}}\uparrow$)	t_{SIK10}	$V_{\text{DD}} = 2.0 \text{ to } 5.5 \text{ V}$	100			ns
			150			ns
SI1 hold time (from $\overline{\text{SCK1}}\uparrow$)	t_{KSI10}		400			ns
SO1 output delay time from $\overline{\text{SCK1}}\downarrow$	t_{KSO10}	C = 100 pF ^{Note} $V_{\text{DD}} = 2.0 \text{ to } 5.5 \text{ V}$			300	ns
					500	ns
$\overline{\text{SCK1}}$ rise/fall time	$t_{\text{R10}}, t_{\text{F10}}$	When using external device expansion function			160	ns
		When not using external device expansion function			1000	ns

Note C is the load capacitance of SO1 output line.

(c) Serial Interface Channel 2

(i) 3-wire serial I/O mode ($\overline{\text{SCK2}}$... Internal clock output)

Parameter	Symbol	Conditions	MIN.	TYP.	MAX.	Unit
$\overline{\text{SCK2}}$ cycle time	t_{KCY11}	$4.5 \text{ V} \leq V_{\text{DD}} \leq 5.5 \text{ V}$	800			ns
		$2.7 \text{ V} \leq V_{\text{DD}} < 4.5 \text{ V}$	1600			ns
		$2.0 \text{ V} \leq V_{\text{DD}} < 2.7 \text{ V}$	3200			ns
			4800			ns
$\overline{\text{SCK2}}$ high/low-level width	$t_{\text{KH11}}, t_{\text{KL11}}$	$V_{\text{DD}} = 4.5 \text{ to } 5.5 \text{ V}$	$t_{\text{KCY11}}/2 - 50$			ns
			$t_{\text{KCY11}}/2 - 100$			ns
SI2 setup time (to $\overline{\text{SCK2}}\uparrow$)	t_{SIK11}	$4.5 \text{ V} \leq V_{\text{DD}} \leq 5.5 \text{ V}$	100			ns
		$2.7 \text{ V} \leq V_{\text{DD}} < 4.5 \text{ V}$	150			ns
		$2.0 \text{ V} \leq V_{\text{DD}} < 2.7 \text{ V}$	300			ns
			400			ns
SI2 hold time (from $\overline{\text{SCK2}}\uparrow$)	t_{SH11}		400			ns
SO2 output delay time from $\overline{\text{SCK2}}\downarrow$	t_{SO11}	$C = 100 \text{ pF}$ Note			300	ns

Note C is the load capacitance of $\overline{\text{SCK2}}$ and SO2 output lines.

(ii) 3-wire serial I/O mode ($\overline{\text{SCK2}}$... External clock input)

Parameter	Symbol	Conditions	MIN.	TYP.	MAX.	Unit
$\overline{\text{SCK2}}$ cycle time	t_{KCY12}	$4.5 \text{ V} \leq V_{\text{DD}} \leq 5.5 \text{ V}$	800			ns
		$2.7 \text{ V} \leq V_{\text{DD}} < 4.5 \text{ V}$	1600			ns
		$2.0 \text{ V} \leq V_{\text{DD}} < 2.7 \text{ V}$	3200			ns
			4800			ns
$\overline{\text{SCK2}}$ high/low-level width	$t_{\text{KH12}}, t_{\text{KL12}}$	$4.5 \text{ V} \leq V_{\text{DD}} \leq 5.5 \text{ V}$	400			ns
		$2.7 \text{ V} \leq V_{\text{DD}} < 4.5 \text{ V}$	800			ns
		$2.0 \text{ V} \leq V_{\text{DD}} < 2.7 \text{ V}$	1600			ns
			2400			ns
SI2 setup time (to $\overline{\text{SCK2}}\uparrow$)	t_{SIK12}	$V_{\text{DD}} = 2.0 \text{ to } 5.5 \text{ V}$	100			ns
			150			ns
SI2 hold time (from $\overline{\text{SCK2}}\uparrow$)	t_{SH12}		400			ns
SO2 output delay time from $\overline{\text{SCK2}}\downarrow$	t_{SO12}	$C = 100 \text{ pF}$ Note	$V_{\text{DD}} = 2.0 \text{ to } 5.5 \text{ V}$		300	ns
					500	ns
$\overline{\text{SCK2}}$ rise/fall time	$t_{\text{R12}}, t_{\text{F12}}$	$V_{\text{DD}} = 4.5 \text{ to } 5.5 \text{ V}$ When not using external device expansion function			1000	ns
					160	ns

Note C is the load capacitance of SO2 output line.

(iii) UART mode (Dedicated baud rate generator output)

Parameter	Symbol	Conditions	MIN.	TYP.	MAX.	Unit
Transfer rate		$4.5\text{ V} \leq V_{DD} \leq 5.5\text{ V}$			78125	bps
		$2.7\text{ V} \leq V_{DD} < 4.5\text{ V}$			39063	bps
		$2.0\text{ V} \leq V_{DD} < 2.7\text{ V}$			19531	bps
					9766	bps

(iv) UART mode (External clock input)

Parameter	Symbol	Conditions	MIN.	TYP.	MAX.	Unit
ASCK cycle time	t _{KCY13}	$4.5\text{ V} \leq V_{DD} \leq 5.5\text{ V}$	800			ns
		$2.7\text{ V} \leq V_{DD} < 4.5\text{ V}$	1600			ns
		$2.0\text{ V} \leq V_{DD} < 2.7\text{ V}$	3200			ns
			4800			ns
ASCK high/low-level width	t _{KH13} , t _{KL13}	$4.5\text{ V} \leq V_{DD} \leq 5.5\text{ V}$	400			ns
		$2.7\text{ V} \leq V_{DD} < 4.5\text{ V}$	800			ns
		$2.0\text{ V} \leq V_{DD} < 2.7\text{ V}$	1600			ns
			2400			ns
Transfer rate		$4.5\text{ V} \leq V_{DD} \leq 5.5\text{ V}$			39063	bps
		$2.7\text{ V} \leq V_{DD} < 4.5\text{ V}$			19531	bps
		$2.0\text{ V} \leq V_{DD} < 2.7\text{ V}$			9766	bps
					6510	bps
ASCK rise/fall time	t _{R13} , t _{F13}	V _{DD} = 4.5 to 5.5 V When not using external device expansion function			1000	ns
					160	ns

AC Timing Test Points (excluding X1, XT1 inputs)

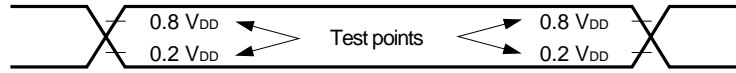

Clock Timing

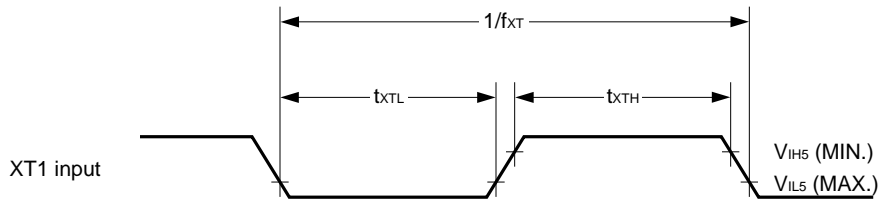
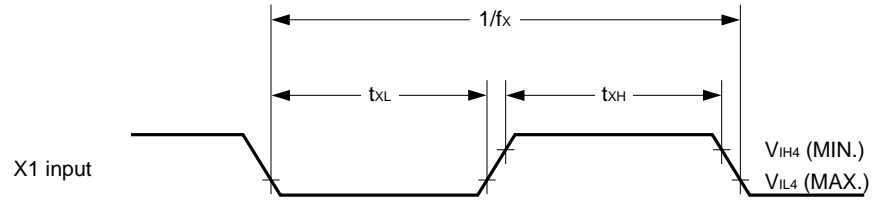

TI Timing

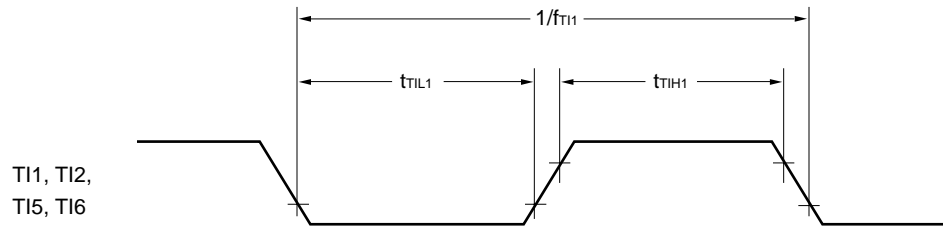
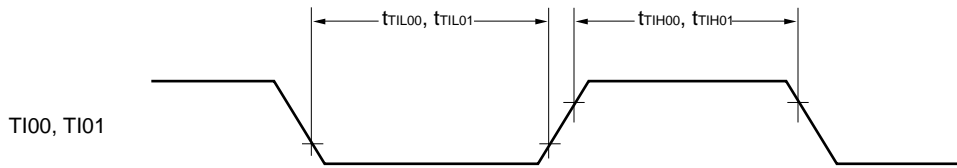

Read/Write Operation

External fetch (no wait) :

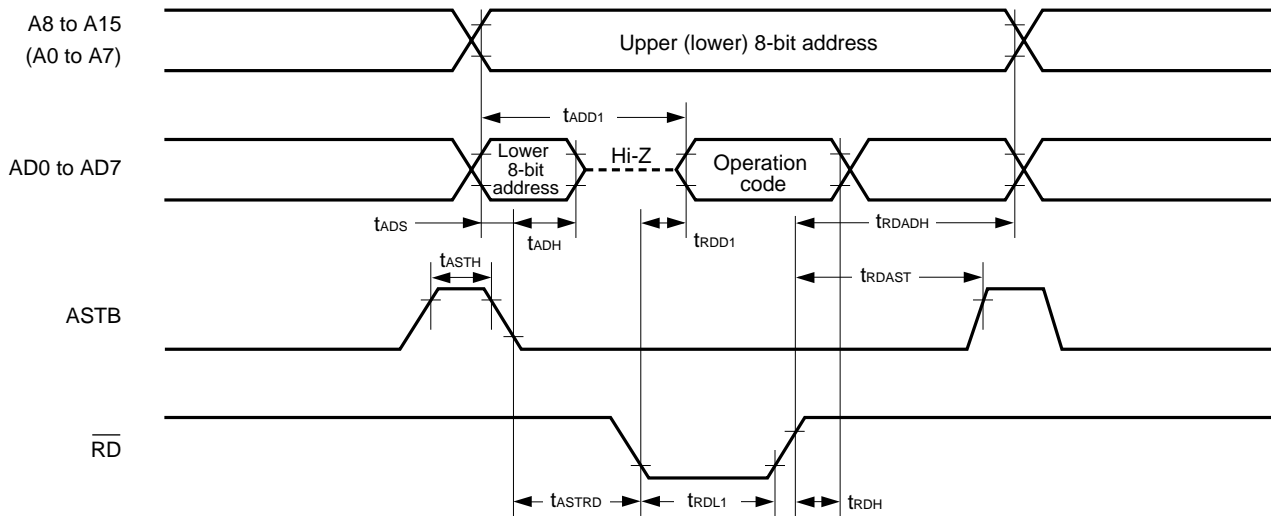

Remark () is valid only in the separate bus mode.

External fetch (wait insertion) :

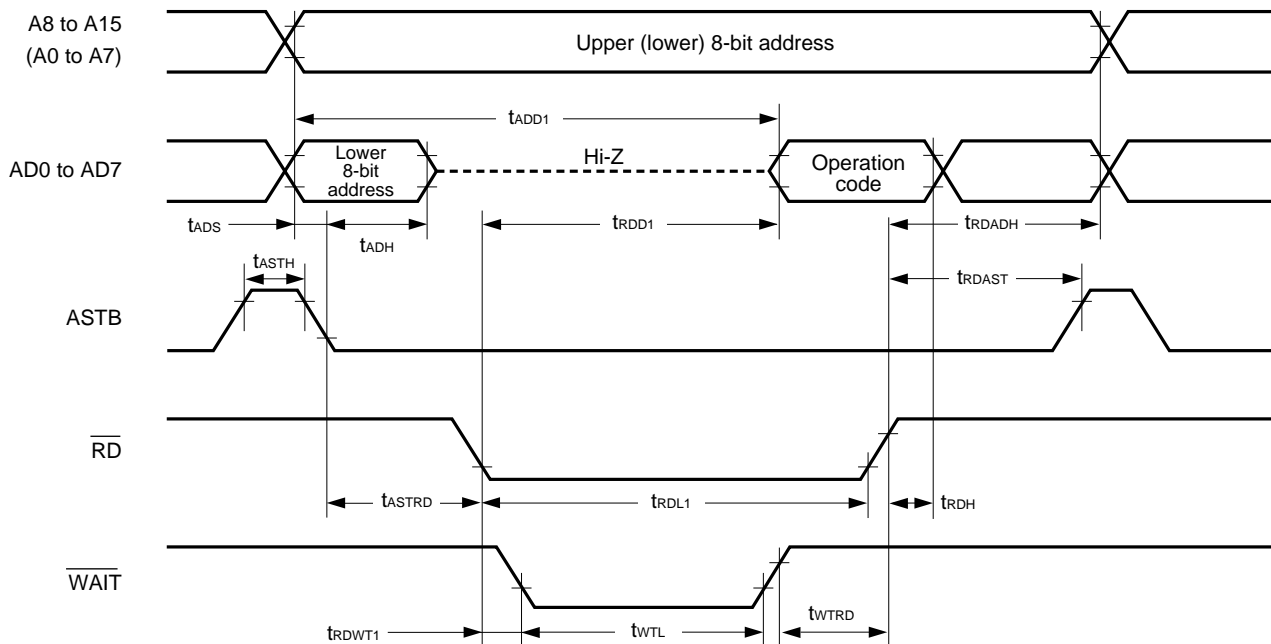

Remark () is valid only in the separate bus mode.

Serial Transfer Timing

3-wire serial I/O mode :

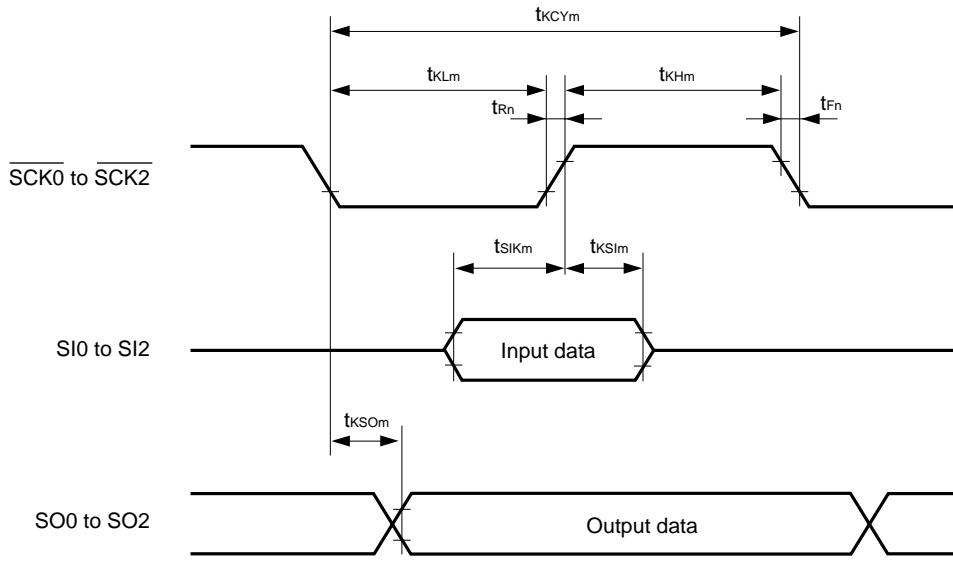

$m = 1, 2, 7, 8, 11, 12$
 $n = 2, 8, 12$

SBI mode (bus release signal transfer) :

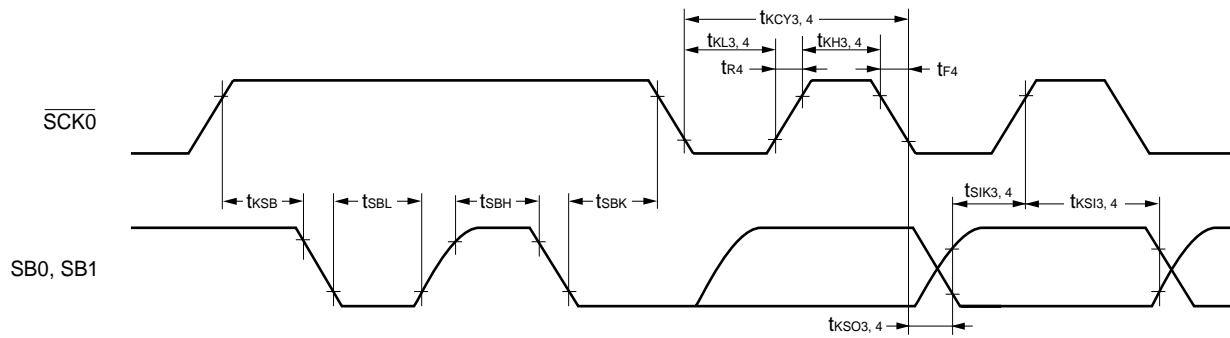

SBI mode (command signal transfer) :

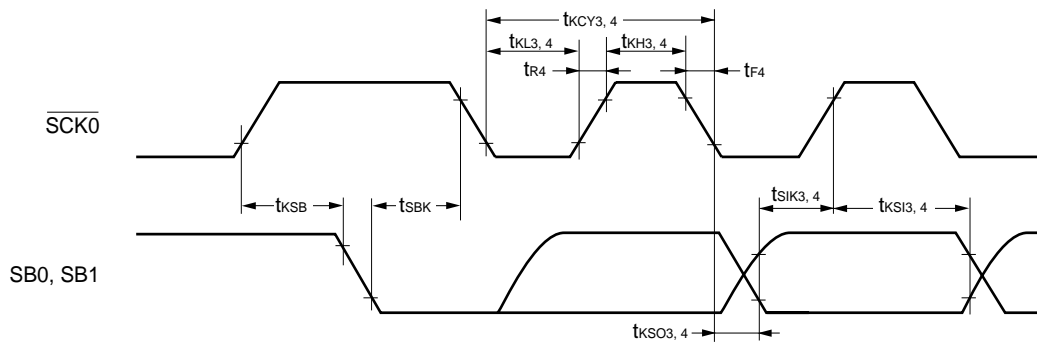

2-wire serial I/O mode :

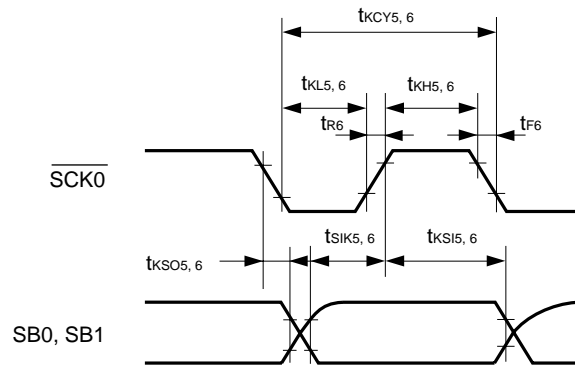

3-wire serial I/O mode with automatic transmit/receive function :

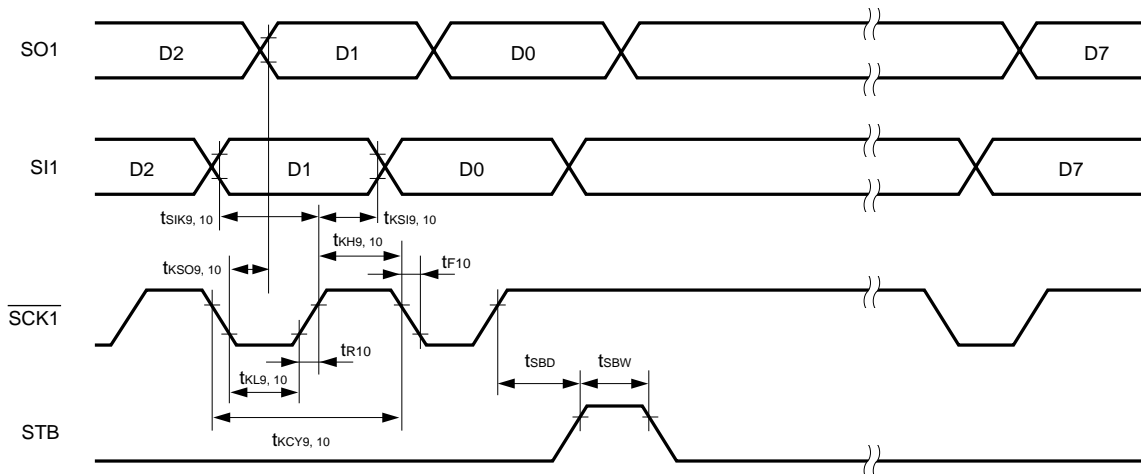

3-wire serial I/O mode with automatic transmit/receive function (busy processing) :

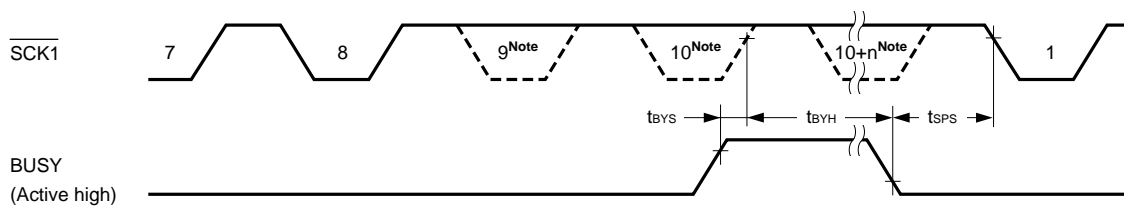

Note The signal is not actually driven low here; it is shown as such to indicate the timing.

UART mode (external clock input) :

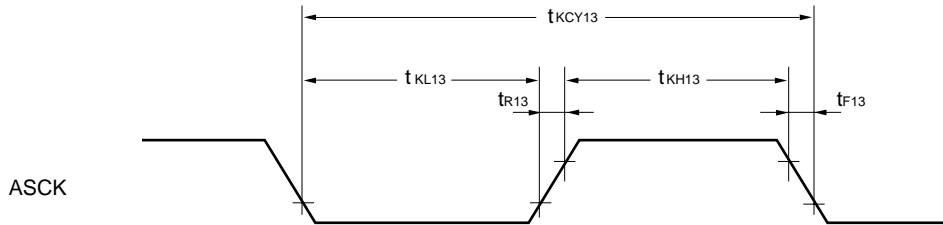

A/D CONVERTER CHARACTERISTICS ($T_A = -40$ to $+85^\circ\text{C}$, $V_{DD} = 1.8$ to 5.5 V, $AV_{SS} = V_{SS} = 0$ V)

Parameter	Symbol	Conditions	MIN.	TYP.	MAX.	Unit
Resolution			8	8	8	bit
Overall error ^{Note}		$2.7\text{ V} \leq AV_{REF0} \leq V_{DD}$			0.6	%
		$1.8\text{ V} \leq AV_{REF0} < 2.7\text{ V}$			1.4	%
Conversion time	t_{CONV}	$2.0\text{ V} \leq AV_{REF0} \leq 5.5\text{ V}$	19.1		200	μs
		$1.8\text{ V} \leq AV_{REF0} < 2.0\text{ V}$	38.2		200	μs
Sampling time	t_{SAMP}		$24/f_{XX}$			μs
Analog input voltage	V_{IAN}		AV_{SS}		AV_{REF0}	V
Reference voltage	AV_{REF0}		1.8		V_{DD}	V
Resistance between AV_{REF0} and AV_{SS}	R_{AIREF0}		4	20		$\text{k}\Omega$

Note Excluding quantization error ($\pm 1/2\text{LSB}$). It is indicated as a ratio to the full-scale value.

Remark f_{XX} : Main system clock frequency (f_x or $f_x/2$)
 f_x : Main system clock oscillation frequency

D/A CONVERTER CHARACTERISTICS ($T_A = -40$ to $+85^\circ\text{C}$, $V_{DD} = 1.8$ to 5.5 V, $AV_{SS} = V_{SS} = 0$ V)

Parameter	Symbol	Conditions	MIN.	TYP.	MAX.	Unit
Resolution					8	bit
Overall error		$R = 2\text{ M}\Omega$ ^{Note 1}			1.2	%
		$R = 4\text{ M}\Omega$ ^{Note 1}			0.8	%
		$R = 10\text{ M}\Omega$ ^{Note 1}			0.6	%
Settling time		^{Note 1} $4.5\text{ V} \leq AV_{REF1} \leq 5.5\text{ V}$			10	μs
		$2.7\text{ V} \leq AV_{REF1} < 4.5\text{ V}$			15	μs
		$1.8\text{ V} \leq AV_{REF1} < 2.7\text{ V}$			20	μs
Output resistance	R_O	Note 2		10		$\text{k}\Omega$
Analog reference voltage	AV_{REF1}		1.8		V_{DD}	V
Resistance between AV_{REF1} and AV_{SS}	R_{AIREF1}	$\text{DACS0, DACS1} = 55\text{H}$ ^{Note 2}	4	8		$\text{k}\Omega$

Notes 1. R and C are D/A converter output pin load resistance and load capacitance, respectively.
 2. Value for 1 D/A converter channel

Remark DACS0, DACS1: D/A conversion value setting register 0, 1

DATA MEMORY STOP MODE LOW SUPPLY VOLTAGE DATA RETENTION CHARACTERISTICS (T_A = -40 to + 85°C)

Parameter	Symbol	Conditions	MIN.	TYP.	MAX.	Unit
Data retention power supply voltage	V _{DDDR}		1.8		5.5	V
Data retention power supply current	I _{DDDR}	V _{DDDR} = 1.8 V Subsystem clock stop and feedback resistor disconnected		0.1	10	μA
Release signal set time	t _{SREL}		0			μs
Oscillation stabilization wait time	t _{WAIT}	Release by $\overline{\text{RESET}}$		2 ¹⁷ /f _x		ms
		Release by interrupt		Note		ms

Note In combination with bit 0 to bit 2 (OSTS0 to OSTS2) of oscillation stabilization time select register (OSTS), selection of 2¹³/f_{xx} and 2¹⁵/f_{xx} to 2¹⁸/f_{xx} is possible.

Remark f_{xx}: Main system clock frequency (f_x or f_x/2)
f_x: Main system clock oscillation frequency

Data Retention Timing (STOP mode release by $\overline{\text{RESET}}$)

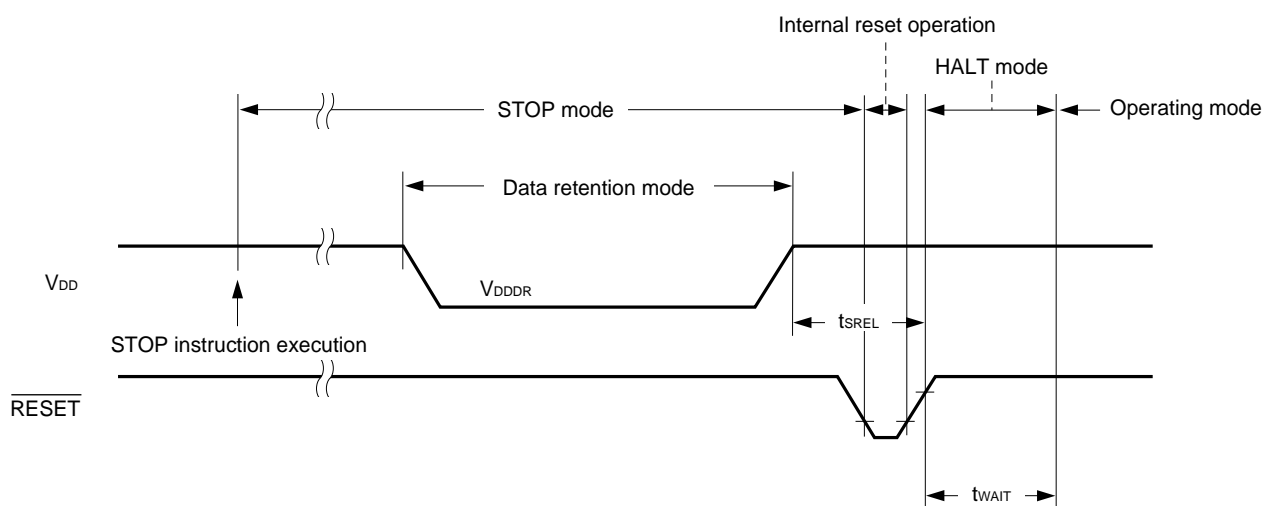

Data Retention Timing (Standby release signal: STOP mode release by interrupt request signal)

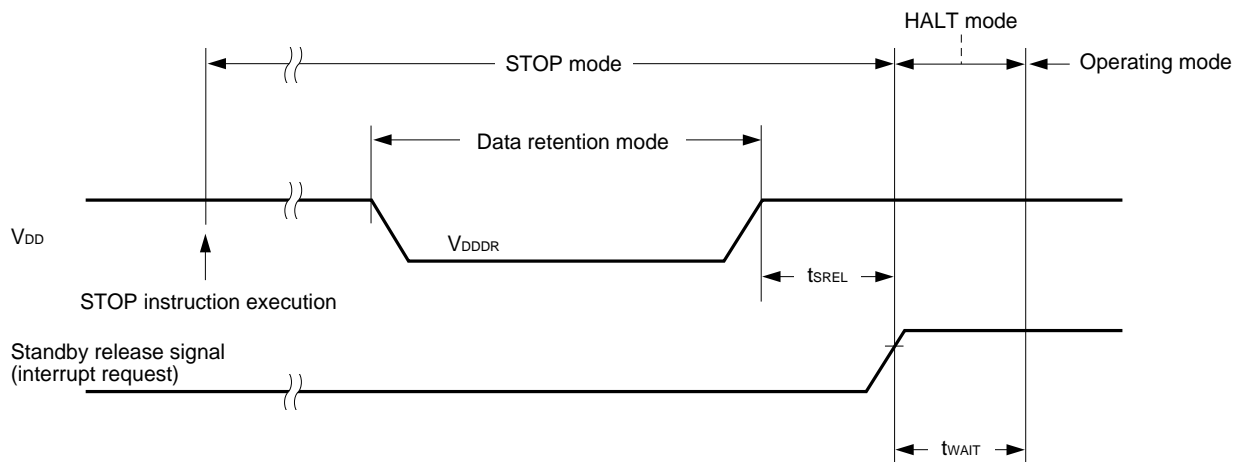

Interrupt Input Timing

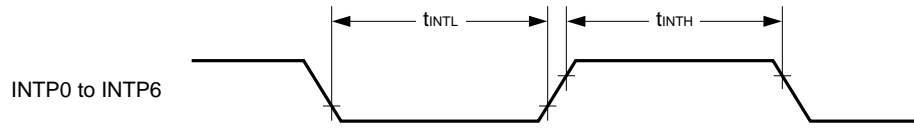

$\overline{\text{RESET}}$ Input Timing

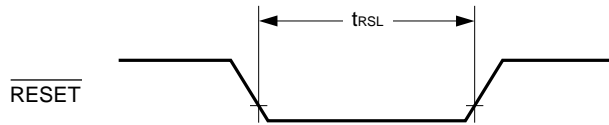

12. CHARACTERISTIC CURVES (FOR REFERENCE ONLY)

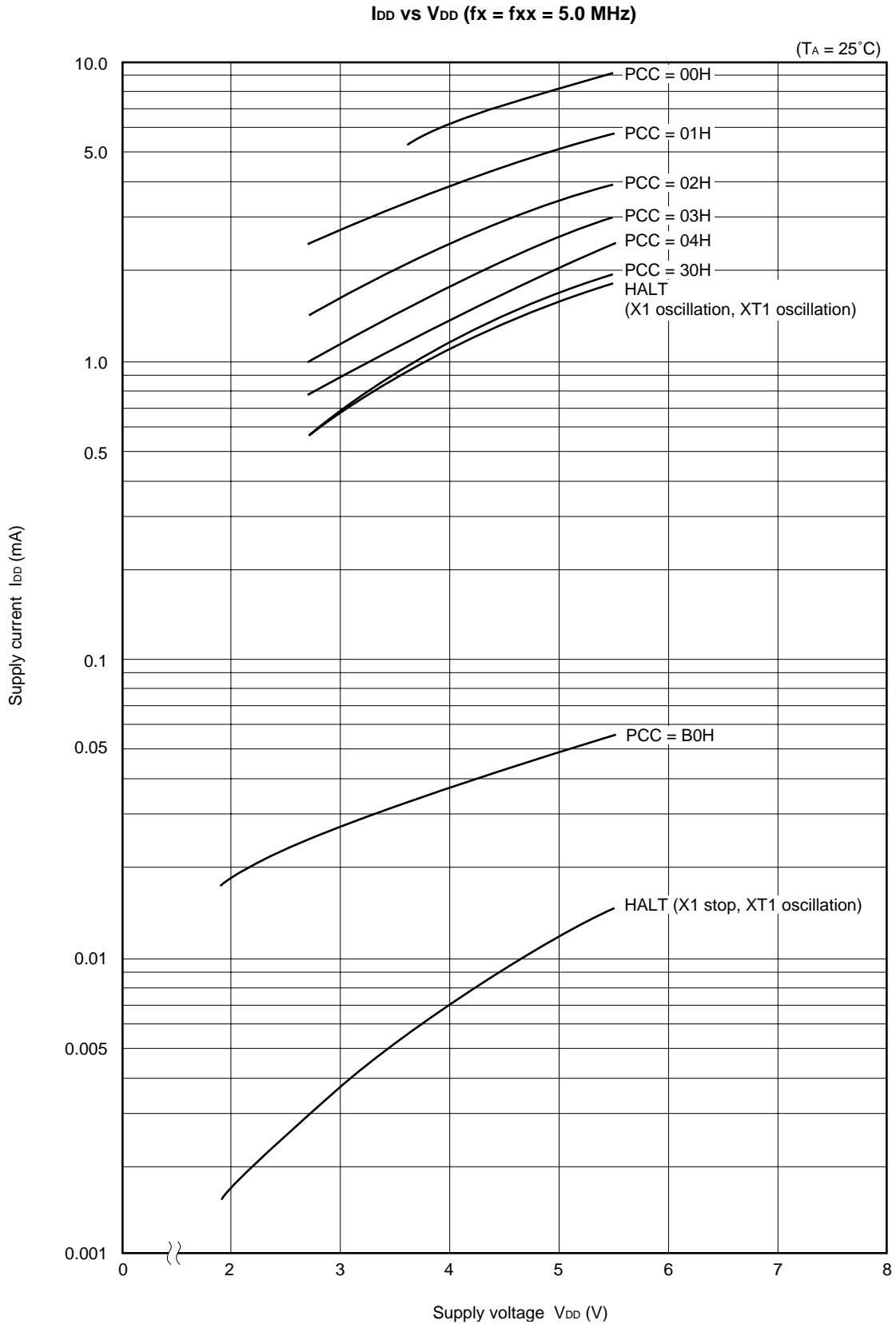

I_{DD} vs V_{DD} (f_x = 5.0 MHz, f_{xx} = 2.5 MHz)

(T_A = 25°C)

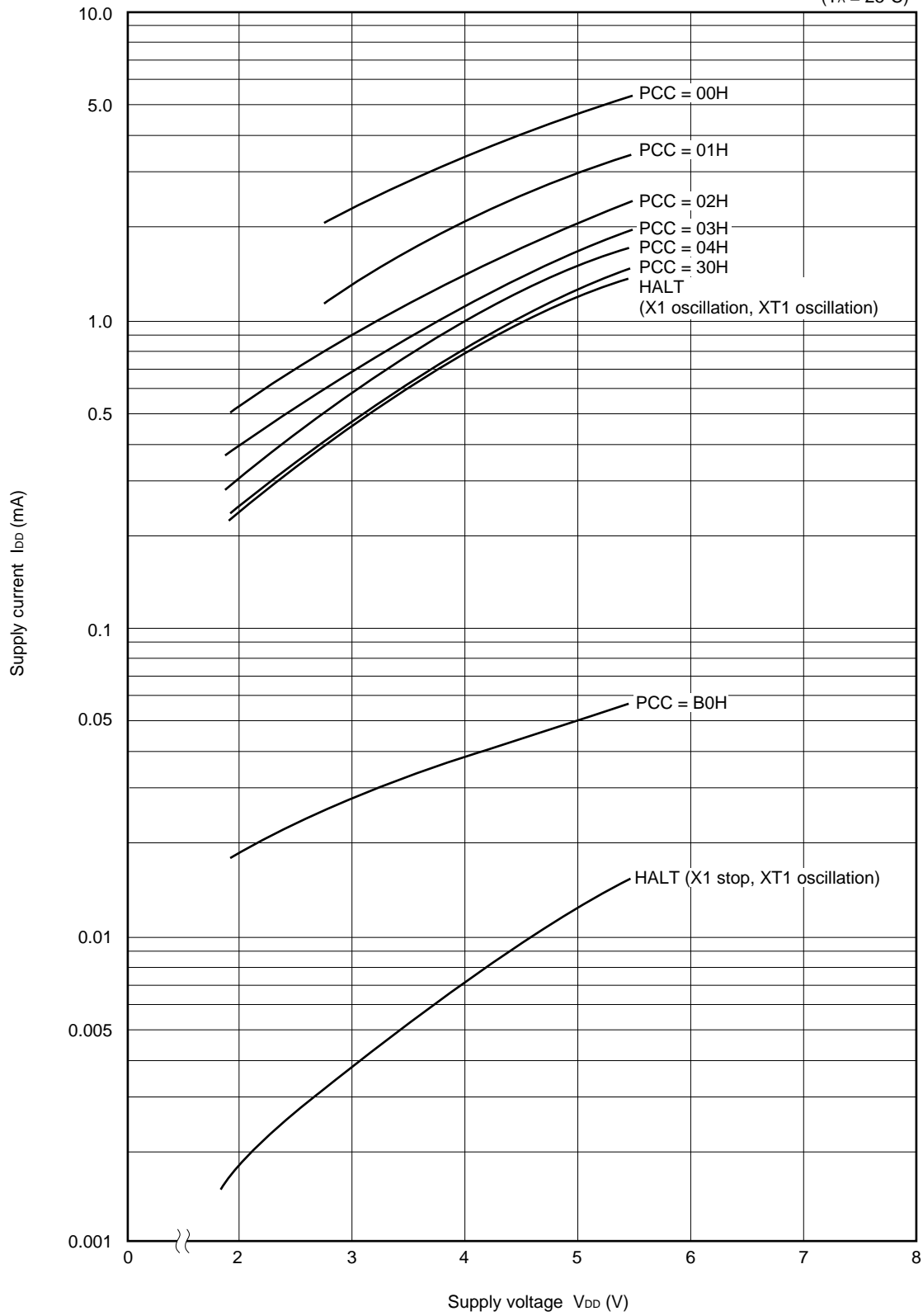

13. PACKAGE DRAWINGS

100 PIN PLASTIC QFP (14 × 20)

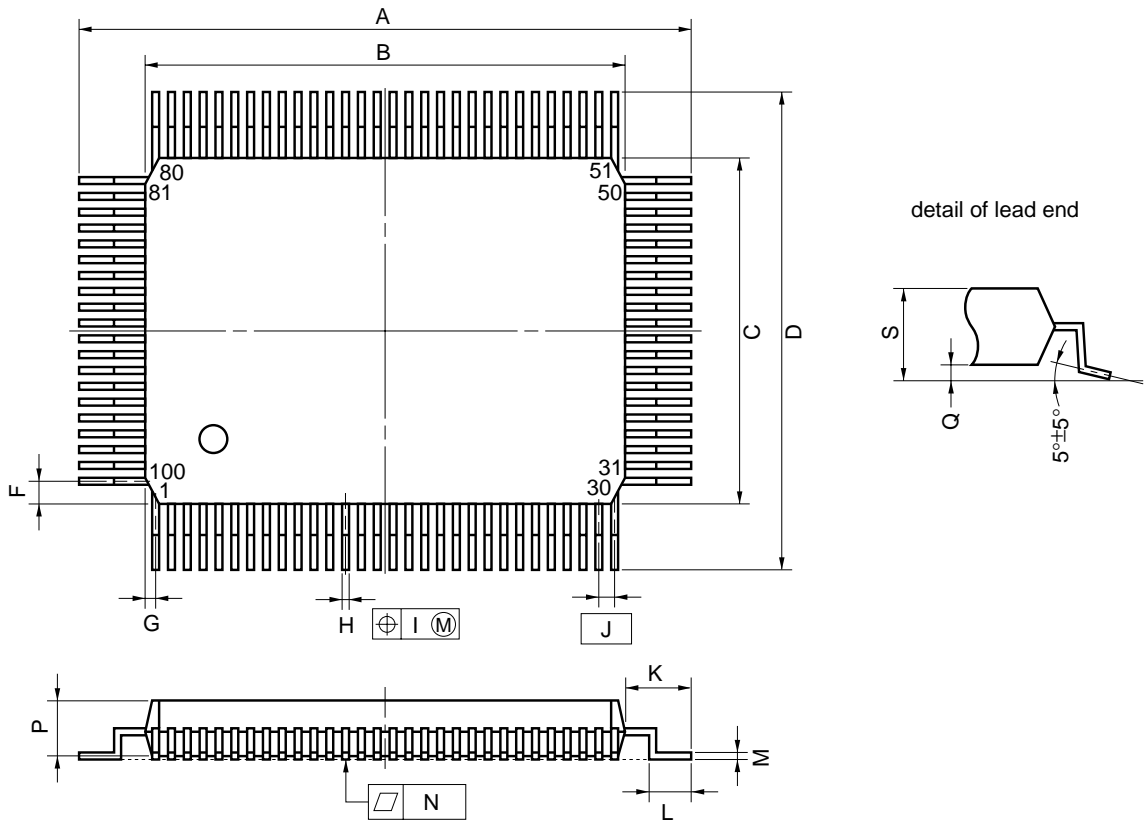

NOTE

Each lead centerline is located within 0.15 mm (0.006 inch) of its true position (T.P.) at maximum material condition.

P100GF-65-3BA1-2

ITEM	MILLIMETERS	INCHES
A	23.6±0.4	0.929±0.016
B	20.0±0.2	0.795 ^{+0.009} _{-0.008}
C	14.0±0.2	0.551 ^{+0.009} _{-0.008}
D	17.6±0.4	0.693±0.016
F	0.8	0.031
G	0.6	0.024
H	0.30±0.10	0.012 ^{+0.004} _{-0.005}
I	0.15	0.006
J	0.65 (T.P.)	0.026 (T.P.)
K	1.8±0.2	0.071 ^{+0.008} _{-0.009}
L	0.8±0.2	0.031 ^{+0.009} _{-0.008}
M	0.15 ^{+0.10} _{-0.05}	0.006 ^{+0.004} _{-0.003}
N	0.10	0.004
P	2.7	0.106
Q	0.1±0.1	0.004±0.004
S	3.0 MAX.	0.119 MAX.

Remark The shape and material of ES versions are the same as those of mass-produced versions.

100 PIN PLASTIC QFP (FINE PITCH) (□14)

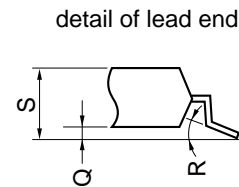
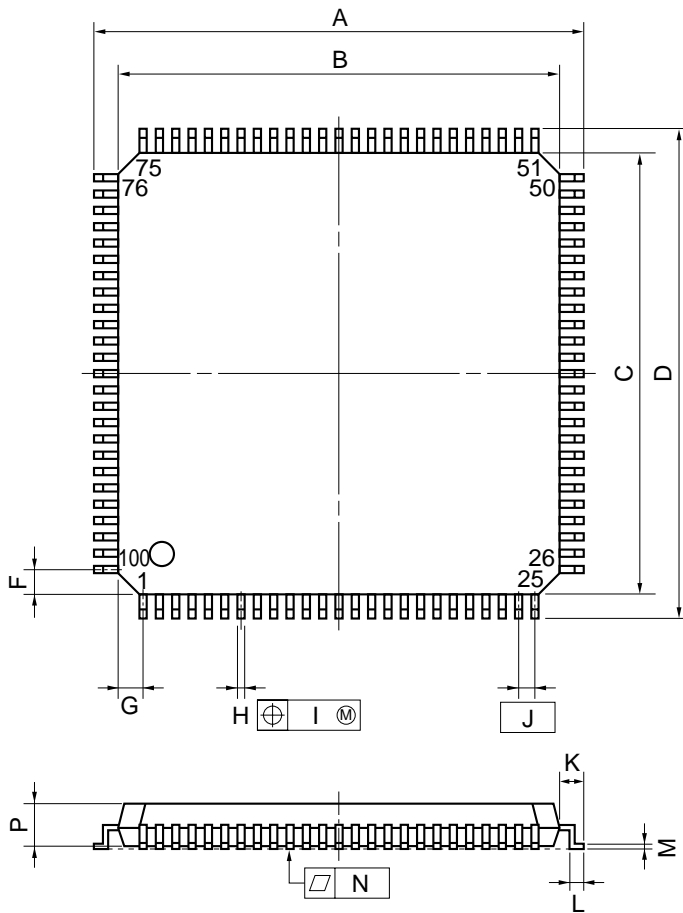

NOTE

Each lead centerline is located within 0.10 mm (0.004 inch) of its true position (T.P.) at maximum material condition.

ITEM	MILLIMETERS	INCHES
A	16.0±0.2	0.630±0.008
B	14.0±0.2	0.551 ^{+0.009} _{-0.008}
C	14.0±0.2	0.551 ^{+0.009} _{-0.008}
D	16.0±0.2	0.630±0.008
F	1.0	0.039
G	1.0	0.039
H	0.22 ^{+0.05} _{-0.04}	0.009±0.002
I	0.10	0.004
J	0.5 (T.P.)	0.020 (T.P.)
K	1.0±0.2	0.039 ^{+0.009} _{-0.008}
L	0.5±0.2	0.020 ^{+0.008} _{-0.009}
M	0.17 ^{+0.03} _{-0.07}	0.007 ^{+0.001} _{-0.003}
N	0.10	0.004
P	1.45	0.057
Q	0.125±0.075	0.005±0.003
R	5°±5°	5°±5°
S	1.7 MAX.	0.067 MAX.

P100GC-50-7EA-2

Remark The shape and material of ES versions are the same as those of mass-produced versions.

14. RECOMMENDED SOLDERING CONDITIONS

The μPD78074B and 78075B should be soldered and mounted under the conditions recommended in the table below.

For detail of recommended soldering conditions, refer to the information document **Semiconductor Device Mounting Technology Manual (C10535E)**.

For soldering methods and conditions other than those recommended below, consult our sales representative.

Table 14-1. Surface Mounting Type Soldering Conditions

- (1) μPD78074BGF-xxx-3BA : 100-pin plastic QFP (14 × 20 mm, resin thickness 2.7 mm)
 μPD78075BGF-xxx-3BA : 100-pin plastic QFP (14 × 20 mm, resin thickness 2.7 mm)

Soldering Method	Soldering Conditions	Symbol
Infrared reflow	Package peak temperature: 235°C, Reflow time: 30 seconds or below (at 210°C or higher), Number of reflow processes: three or less	IR35-00-3
VPS	Package peak temperature: 215°C, Reflow time: 40 seconds or below (at 200°C or higher), Number of reflow processes: three or less	VP15-00-3
Wave soldering	Solder temperature: 260°C or below, Flow time: 10 seconds or below, Number of flow processes: once, Preheating temperature: 120°C or below (package surface temperature)	WS60-00-1
Pin partial heating	Pin temperature: 300°C or below, Time: 3 seconds or below (per device side)	—

- (2) μPD78074BGC-xxx-7EA : 100-pin plastic QFP (fine pitch) (14 × 14 mm, resin thickness 1.45 mm)
 μPD78075BGC-xxx-7EA : 100-pin plastic QFP (fine pitch) (14 × 14 mm, resin thickness 1.45 mm)

Soldering Method	Soldering Conditions	Symbol
Infrared reflow	Package peak temperature: 235°C, Reflow time: 30 seconds or below (at 210°C or higher), Number of reflow processes: two or less Exposure limit: 7 days ^{Note} (after that, prebaking is necessary at 125°C for 10 hours)	IR35-107-2
VPS	Package peak temperature: 215°C, Reflow time: 40 seconds or below (at 200°C or higher), Number of reflow processes: two or less Exposure limit: 7 days ^{Note} (after that, prebaking is necessary at 125°C for 10 hours)	VP15-107-2
Pin partial heating	Pin temperature: 300°C or below, Time: 3 seconds or below (per device side)	—

Note Exposure limit after dry-pack is opened. Storage conditions: temperature of 25°C and relative humidity of 65% or less.

Caution Use of more than one soldering method should be avoided (except for the pin partial heating method).

APPENDIX A. DEVELOPMENT TOOLS

The following tools are available for system development using the μPD78074B and 78075B.

Language Processing Software

RA78K/0 ^{Notes 1, 2, 3, 4}	Assembler package used in common for the 78K/0 Series
CC78K/0 ^{Notes 1, 2, 3, 4}	C compiler package used in common for the 78K/0 Series
DF78078 ^{Notes 1, 2, 3, 4}	Device file used in common for the μPD78078 Subseries
CC78K/0-L ^{Notes 1, 2, 3, 4}	C compiler library source file used in common for the 78K/0 Series

PROM Writing Tools

PG-1500	PROM programmer
PA-78P078GF PA-78P078GC PA-78P078KL-T	Programmer adapter connected to the PG-1500
PG-1500 controller ^{Notes 1, 2}	Control program for the PG-1500

Debugging Tools

IE-78000-R	In-circuit emulator used in common for the 78K/0 Series
IE-78000-R-A	In-circuit emulator used in common for the 78K/0 Series (for integrated debugger)
IE-78000-R-BK	Break board used in common for the 78K/0 Series
IE-78078-R-EM	Emulation board used in common for the μPD78078 Subseries
EP-78064GC-R EP-78064GF-R	Emulation probe used in common for the μPD78064 Subseries
EV-9200GF-100	Socket mounted on the target system board prepared for 100-pin plastic QFP (GF-3BA type)
TGC-100SDW	Adapter mounted on the target system board prepared for 100-pin plastic LQFP (GC-7EA type) TGC-100SDW is made by Tokyo Eletech Corporation (Tokyo 03-5295-1661). Contact an NEC sales representative for details.
EV-9900	Jig used for removing the μPD78P078KL-T from the EV-9200GF-100
SM78K0 ^{Notes 4, 5, 6, 7}	System simulator used in common for the 78K/0 Series
ID78K0 ^{Notes 4, 5, 6, 7}	Integrated debugger for the IE-78000-R-A
SD78K/0 ^{Notes 1, 2}	Screen debugger for the IE-78000-R
DF78078 ^{Notes 1, 2, 4, 5, 6, 7}	Device file used in common for the μPD78078 Subseries

Real-Time OS

RX78K/0 ^{Notes 1, 2, 3, 4}	Real-time OS used for the 78K/0 Series
MX78K0 ^{Notes 1, 2, 3, 4}	OS used for the 78K/0 Series

Fuzzy Inference Development Support System

FE9000 ^{Note 1} /FE9200 ^{Note 5}	Fuzzy knowledge data input tool
FT9080 ^{Note 1} /FT9085 ^{Note 2}	Translator
FI78K0 ^{Notes 1, 2}	Fuzzy inference module
FD78K0 ^{Notes 1, 2}	Fuzzy inference debugger

Notes 1. PC-9800 Series (MS-DOS™) based

2. IBM PC/AT™ and compatibles (PC DOS™/IBM DOS™/MS-DOS) based

3. HP9000 Series 300™ (HP-UX™) based

4. HP9000 Series 700™ (HP-UX), SPARCstation™ (SunOS™), and EWS4800 Series (EWS-UX/V) based

5. PC-9800 Series (MS-DOS+Windows™) based

6. IBM PC/AT and compatibles (PC DOS/IBM DOS/MS-DOS+Windows) based

7. NEWS™ (NEWS-OS™) based

Remarks 1. For development tools supplied by third-party manufacturers, refer to **78K/0 Series Selection Guide (U11126E)**.

2. Use the RA78K/0, CC78K/0, SM78K0, ID78K0, SD78K/0, and RX78K/0 in combination with the DF78078.

APPENDIX B. RELATED DOCUMENTS

Documents Related to Devices

Document Name	Document No.	
	Japanese	English
μPD78075B, 78075BY Subseries User's Manual	In preparation	Planned
μPD78074B, 78075B Data Sheet	U12017J	This document
μPD78P078 Data Sheet	U10168J	U10168E
78K/0 Series User's Manual—Instructions	IEU-849	IEU-1372
78K/0 Series Instruction Table	U10903J	—
78K/0 Series Instruction Set	U10904J	—
μPD78078 Subseries Special Function Register Table	IEM-5607	—
78K/0 Series Application Note—Fundamental (III)	IEA-767	U10182E

Development Tool Documents (User's Manual)

Document Name	Document No.		
	Japanese	English	
RA78K Series Assembler Package	Operation	EEU-809	EEU-1399
	Language	EEU-815	EEU-1404
RA78K Series Structured Assembler Preprocessor	EEU-817	EEU-1402	
RA78K0 Assembler Package	Operation	U11802J	U11802E
	Assembly Language	U11801J	U11801E
	Structured Assembly Language	U11789J	U11789E
CC78K Series C Compiler	Operation	EEU-656	EEU-1280
	Language	EEU-655	EEU-1284
CC78K/0 C Compiler	Operation	U11517J	U11517E
	Language	U11518J	U11518E
CC78K/0 C Compiler Application Note	Programming Know-how	EEA-618	EEA-1208
CC78K Series Library Source File	EEU-777	—	
PG-1500 PROM Programmer	EEU-651	EEU-1335	
PG-1500 Controller PC-9800 Series (MS-DOS) Based	EEU-704	EEU-1291	
PG-1500 Controller IBM PC Series (PC DOS) Based	EEU-5008	U10540E	
IE-78000-R	EEU-810	U11376E	
IE-78000-R-BK	EEU-867	EEU-1427	
IE-78000-R-A	U10057J	U10057E	
IE-78078-R-EM	U10775J	U10775E	
EP-78064	EEU-934	EEU-1522	
SM78K0 System Simulator Windows Based	Reference	U10181J	U10181E
SM78K Series System Simulator	External Part User Open Interface Specifications	U10092J	U10092E
ID78K0 Integrated Debugger EWS Based	Reference	U11151J	—
ID78K0 Integrated Debugger Windows Based	Guide	U11649J	U11649E
ID78K0 Integrated Debugger PC Based	Reference	U11539J	U11539E
SD78K/0 Screen Debugger PC-9800 Series (MS-DOS) Based	Introduction	EEU-852	—
	Reference	U10952J	—
SD78K/0 Screen Debugger IBM PC/AT (PC DOS) Based	Introduction	EEU-5024	EEU-1414
	Reference	U11279J	EEU-1413

Caution The contents of the documents listed above are subject to change without prior notice. Be sure to use the latest edition when starting design.

Embedded Software Documents (User's Manual)

Document Name		Document No.	
		Japanese	English
78K/0 Series Real-time OS	Basic	U11537J	—
	Installation	U11536J	—
78K/0 Series OS MX78K0	Basic	EEU-5010	—
Fuzzy Knowledge Data Input Tools		EEU-829	EEU-1438
78K/0, 78K/II, and 87AD Series Fuzzy Inference Development Support System Translator		EEU-862	EEU-1444
78K/0 Series Fuzzy Inference Development Support System Fuzzy Inference Module		EEU-858	EEU-1441
78K/0 Series Fuzzy Inference Development Support System Fuzzy Inference Knowledge Debugger		EEU-921	EEU-1458

Other Documents

Document Name		Document No.	
		Japanese	English
IC Package Manual		C10943X	
Semiconductor Device Mounting Technology Manual		C10535J	C10535E
Quality Grades on NEC Semiconductor Devices		C11531J	C11531E
NEC Semiconductor Device Reliability/Quality Control System		C10983J	C10983E
Electrostatic Discharge (ESD) Test		MEM-539	—
Guide to Quality Assurance for Semiconductor Devices		C11893J	MEI-1202
Microcomputer Product Series Guide		U11416J	—

Caution The contents of the documents listed above are subject to change without prior notice. Be sure to use the latest edition when starting design.

NOTES FOR CMOS DEVICES

① PRECAUTION AGAINST ESD FOR SEMICONDUCTORS

Note: Strong electric field, when exposed to a MOS device, can cause destruction of the gate oxide and ultimately degrade the device operation. Steps must be taken to stop generation of static electricity as much as possible, and quickly dissipate it once, when it has occurred. Environmental control must be adequate. When it is dry, humidifier should be used. It is recommended to avoid using insulators that easily build static electricity. Semiconductor devices must be stored and transported in an anti-static container, static shielding bag or conductive material. All test and measurement tools including work bench and floor should be grounded. The operator should be grounded using wrist strap. Semiconductor devices must not be touched with bare hands. Similar precautions need to be taken for PW boards with semiconductor devices on it.

② HANDLING OF UNUSED INPUT PINS FOR CMOS

Note: No connection for CMOS device inputs can be cause of malfunction. If no connection is provided to the input pins, it is possible that an internal input level may be generated due to noise, etc., hence causing malfunction. CMOS device behave differently than Bipolar or NMOS devices. Input levels of CMOS devices must be fixed high or low by using a pull-up or pull-down circuitry. Each unused pin should be connected to V_{DD} or GND with a resistor, if it is considered to have a possibility of being an output pin. All handling related to the unused pins must be judged device by device and related specifications governing the devices.

③ STATUS BEFORE INITIALIZATION OF MOS DEVICES

Note: Power-on does not necessarily define initial status of MOS device. Production process of MOS does not define the initial operation status of the device. Immediately after the power source is turned ON, the devices with reset function have not yet been initialized. Hence, power-on does not guarantee out-pin levels, I/O settings or contents of registers. Device is not initialized until the reset signal is received. Reset operation must be executed immediately after power-on for devices having reset function.

Regional Information

Some information contained in this document may vary from country to country. Before using any NEC product in your application, please contact the NEC office in your country to obtain a list of authorized representatives and distributors. They will verify:

- Device availability
- Ordering information
- Product release schedule
- Availability of related technical literature
- Development environment specifications (for example, specifications for third-party tools and components, host computers, power plugs, AC supply voltages, and so forth)
- Network requirements

In addition, trademarks, registered trademarks, export restrictions, and other legal issues may also vary from country to country.

NEC Electronics Inc. (U.S.)

Santa Clara, California
Tel: 800-366-9782
Fax: 800-729-9288

NEC Electronics (Germany) GmbH

Duesseldorf, Germany
Tel: 0211-65 03 02
Fax: 0211-65 03 490

NEC Electronics (UK) Ltd.

Milton Keynes, UK
Tel: 01908-691-133
Fax: 01908-670-290

NEC Electronics Italiana s.r.l.

Milano, Italy
Tel: 02-66 75 41
Fax: 02-66 75 42 99

NEC Electronics (Germany) GmbH

Benelux Office
Eindhoven, The Netherlands
Tel: 040-2445845
Fax: 040-2444580

NEC Electronics (France) S.A.

Velizy-Villacoublay, France
Tel: 01-30-67 58 00
Fax: 01-30-67 58 99

NEC Electronics (France) S.A.

Spain Office
Madrid, Spain
Tel: 01-504-2787
Fax: 01-504-2860

NEC Electronics (Germany) GmbH

Scandinavia Office
Taeby, Sweden
Tel: 08-63 80 820
Fax: 08-63 80 388

NEC Electronics Hong Kong Ltd.

Hong Kong
Tel: 2886-9318
Fax: 2886-9022/9044

NEC Electronics Hong Kong Ltd.

Seoul Branch
Seoul, Korea
Tel: 02-528-0303
Fax: 02-528-4411

NEC Electronics Singapore Pte. Ltd.

United Square, Singapore 1130
Tel: 253-8311
Fax: 250-3583

NEC Electronics Taiwan Ltd.

Taipei, Taiwan
Tel: 02-719-2377
Fax: 02-719-5951

NEC do Brasil S.A.

Sao Paulo-SP, Brasil
Tel: 011-889-1680
Fax: 011-889-1689

FIP and IEBus are trademarks of NEC Corporation.

MS-DOS and Windows are either registered trademarks or trademarks of Microsoft Corporation in the United States and/or other countries.

IBM DOS, PC/AT, and PC DOS are trademarks of International Business Machines Corporation.

HP9000 Series 300, HP9000 Series 700, and HP-UX are trademarks of Hewlett-Packard Company.

SPARCstation is a trademark of SPARC International, Inc.

SunOS is a trademark of Sun Microsystems, Inc.

NEWS and NEWS-OS are trademarks of Sony Corporation.

The related documents indicated in this publication may include preliminary versions. However, preliminary versions are not marked as such.

The export of this product from Japan is regulated by the Japanese government. To export this product may be prohibited without governmental license, the need for which must be judged by the customer. The export or re-export of this product from a country other than Japan may also be prohibited without a license from that country. Please call an NEC sales representative.

No part of this document may be copied or reproduced in any form or by any means without the prior written consent of NEC Corporation. NEC Corporation assumes no responsibility for any errors which may appear in this document.

NEC Corporation does not assume any liability for infringement of patents, copyrights or other intellectual property rights of third parties by or arising from use of a device described herein or any other liability arising from use of such device. No license, either express, implied or otherwise, is granted under any patents, copyrights or other intellectual property rights of NEC Corporation or others.

While NEC Corporation has been making continuous effort to enhance the reliability of its semiconductor devices, the possibility of defects cannot be eliminated entirely. To minimize risks of damage or injury to persons or property arising from a defect in an NEC semiconductor device, customers must incorporate sufficient safety measures in its design, such as redundancy, fire-containment, and anti-failure features.

NEC devices are classified into the following three quality grades:

"Standard", "Special", and "Specific". The Specific quality grade applies only to devices developed based on a customer designated "quality assurance program" for a specific application. The recommended applications of a device depend on its quality grade, as indicated below. Customers must check the quality grade of each device before using it in a particular application.

Standard: Computers, office equipment, communications equipment, test and measurement equipment, audio and visual equipment, home electronic appliances, machine tools, personal electronic equipment and industrial robots

Special: Transportation equipment (automobiles, trains, ships, etc.), traffic control systems, anti-disaster systems, anti-crime systems, safety equipment and medical equipment (not specifically designed for life support)

Specific: Aircrafts, aerospace equipment, submersible repeaters, nuclear reactor control systems, life support systems or medical equipment for life support, etc.

The quality grade of NEC devices is "Standard" unless otherwise specified in NEC's Data Sheets or Data Books. If customers intend to use NEC devices for applications other than those specified for Standard quality grade, they should contact an NEC sales representative in advance.

Anti-radioactive design is not implemented in this product.