

Brief Description

The ZLED7012, one of our ZLED family of LED control ICs, is a low-noise, constant-frequency charge pump DC/DC converter that can drive up to four LED channels, providing a programmable constant current level ranging from 1.8mA to 20mA per LED channel. It can also drive higher current LEDs because its current sinks can operate in parallel. It enables white or other color LED applications that require uniform intensity and/or linear progressions in brightness. Capable of operating efficiently with DC voltage supplies ranging from 2.8V to 5.5V, it is ideal for small, battery-powered applications because very few external components are needed: typically one small-dimension 1μF capacitor across the C+ and C- pins and two small-dimension 2.2μF capacitors to GND from the VCC and Vout pins.

The ZLED7012's Pulse Count Control (PCC) serial digital input is used to enable/disable the LEDs and set the current level (14 settings using a nearly logarithmic scale to provide a linear brightness progression). This simple, high-speed interface allows efficient real-time management of LEDs via microcontrollers or control systems.

The ZLED7012's features include integrated soft-start circuitry to protect against excessive in-rush current during power-on and a low-current shutdown mode that reduces quiescent current consumption to approximately 1μA (typical) by disconnecting the load from the input when the EN/SET pin is low for a specified time.

Features

- Low quiescent current in low-current shutdown mode: 1μA typical; <2μA maximum
- Integrated thermal shutdown protection prevents damage by shutting down the ZLED7012 if the die junction temperature exceeds 160°C (typical)
- Fixed charge pump switching frequency: 1MHz (typ.)
- Soft-start feature protects against excessive inrush current during power-on

Benefits

- Current matching accuracy: ±0.9% (typical)
- One-pin on/off or brightness control for up to four LEDs via a simple PCC serial interface—no pulse-width modulation or additional control circuit needed
- 14 programmable current levels for achieving real-time control of effects such as LED fade-out or sudden changes in brightness
- Low EMI and back-injected noise because the charge pump is not inductor-based
- Very few external components needed for operation
- Flexible design enables diverse LED applications: up to 20mA per channel
- LED driver family concept with low-voltage six-channel LED driver ZLED7022

Available Support

- Evaluation Kit

Physical Characteristics

- Voltage supply: 2.8V to 5.5V DC
- Operating temperature: -40°C to 85°C
- Small footprint 12-pin UTQFN package (2mm×2mm)

ZLED7012 Application Circuit

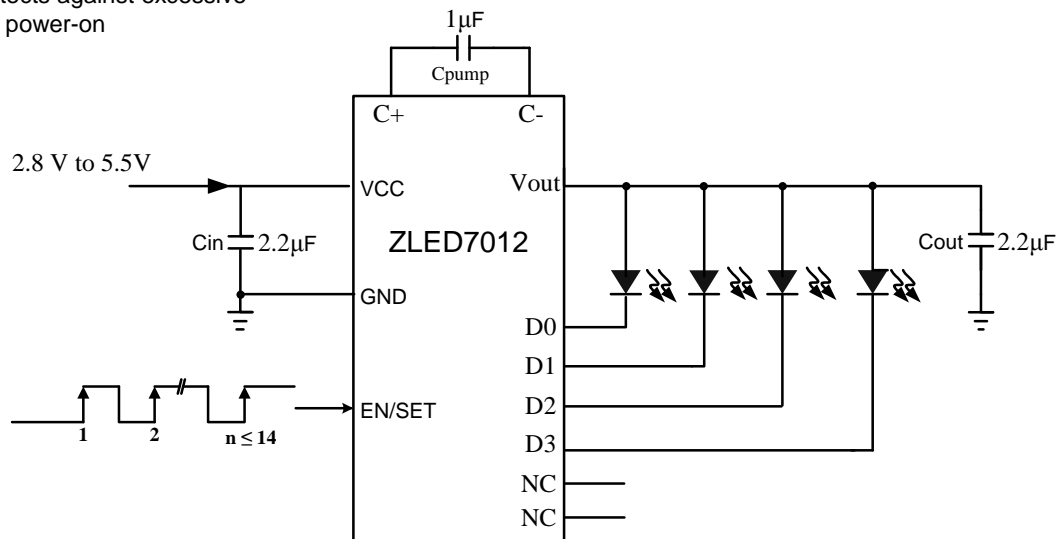

Block Diagram

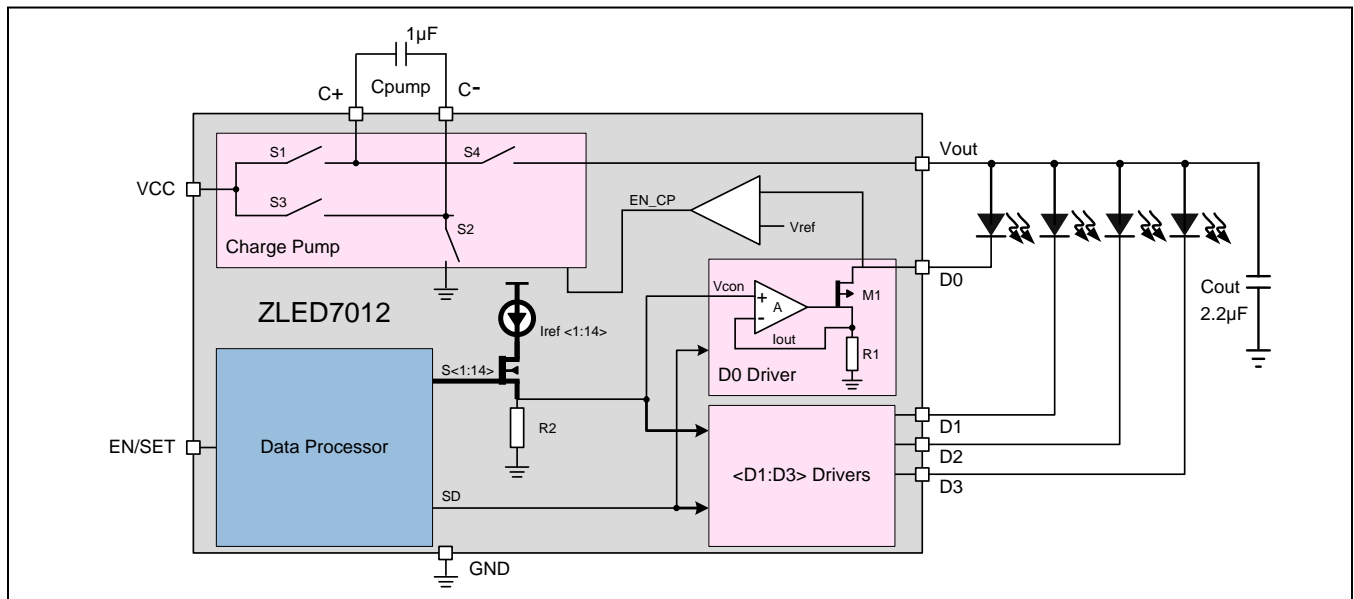

Typical Applications

- ❖ LED backlighting for portable devices
- ❖ LED lighting for cell phones, smartphones, PDAs
- ❖ Illumination of digital photo frames
- ❖ Backlighting for GPS / navigation systems
- ❖ Low voltage LED lighting fixtures
- ❖ General purpose low-voltage industrial and consumer applications

Ordering Information

Product Sales Code	Description	Package
ZLED7012ZI1R	ZLED7012 – Low-Voltage Four-Channel LED Driver	UTQFN12 (2x2)mm Tape & Reel
ZLED7012KIT-E1	ZLED7012 Evaluation Board	Kit

Contents

1	IC Characteristics	5
1.1.	Absolute Maximum Ratings	5
1.2.	Operating Conditions	5
1.3.	Electrical Parameters	5
1.4.	Typical Performance Graphs	6
2	Circuit Description	8
2.1.	Block Diagram	8
2.2.	ZLED7012 Overview	8
2.3.	ZLED7012 Soft-Start Feature	9
2.4.	ZLED7012 Low-Current Shutdown Mode	9
2.5.	LED Current Control	9
2.6.	PCC Serial Digital Interface	10
3	Operating Conditions	10
3.1.	RF Noise Reduction	10
3.2.	ZLED7012 Thermal Protection	10
4	Application Circuit Design	11
4.1.	Applications	11
4.2.	External Components	11
4.2.1.	External Capacitors Cout and Cin	11
4.2.2.	External Pump Capacitor	11
4.2.3.	LEDs	12
4.3.	Unused LED Driver Pins	12
5	ESD Protection	12
6	Pin Configuration and Package	12
7	Ordering Information	14
8	Glossary	14
9	Document Revision History	14

List of Figures

Figure 1.1	Operating Current I_{CC} over Supply Voltage V_{CC} Range (2.8V to 5.5V) at 25°C	6
Figure 1.2	LED Current over Supply Voltage V_{CC} Range (2.8V to 5.5V) for Outputs D0:D3 (LED0:LED3)	7
Figure 1.3	Shutdown Current I_{SD} over Supply Voltage V_{CC} Range (2.8V to 5.5V)	7
Figure 1.4	Current I_{CC} over Temperature Range (-40°C to +85°C)	7
Figure 1.5	Efficiency (%) over the V_{CC} Range (2.8V to 5.5V) at 25°C	8
Figure 2.1	PCC Serial Digital Interface Signal Timing	10
Figure 4.1	Basic Application Circuit using D2:D0	11
Figure 6.1	Pin Configuration ZLED7012 – Top View	12
Figure 6.2	UTQFN-12 Package Drawing	13

List of Tables

Table 2.1	Current Output Settings	9
Table 6.1	Layout Requirements and Pin Descriptions—12-pin UTQFN Package	13
Table 6.2	UTQFN-12 Package Dimensions	13

1 IC Characteristics

1.1. Absolute Maximum Ratings

No.	PARAMETER	SYMBOL	CONDITIONS	MIN	TYP	MAX	UNIT
1.1.1	Input voltage referenced to ground	V_{CC}		-0.3		6.0	V
1.1.2	EN/SET voltage referenced to ground	$V_{EN/SET}$		-0.3		$V_{CC}+0.3$	V
1.1.3	Maximum soldering temperature	T_{LEAD}	At ZLED7012 lead; 10 seconds maximum			300	°C
1.1.4	Maximum Thermal Resistance	θ_{JA}	UTQFN-12 package			60	°C/W
1.1.5	Junction temperature	T_J		-40		150	°C

1.2. Operating Conditions

No.	PARAMETER	SYMBOL	CONDITIONS	MIN	TYP	MAX	UNIT
1.2.1	Operating temperature	T_{amb}		-40		+85	°C
1.2.2	Input voltage	V_{CC}		2.8		5.5	V

1.3. Electrical Parameters

Except as noted, conditions for the following specifications are $T_{amb} = -40^{\circ}\text{C}$ to $+85^{\circ}\text{C}$ (25°C typical); $V_{CC} = 2.8\text{V}$ to 5.5V ; $C_{in} = C_{out} = 2.2\mu\text{F}$; $C_{pump} = 1\mu\text{F}$

Production testing is at 25°C . At other temperatures within the specified operating range, functional operation of the ZLED7012 and specified parameters are guaranteed by characterization, design, and process control.

Parameters marked with an asterisk (*) are guaranteed by design.

No.	PARAMETER	SYMBOL	CONDITIONS	MIN	TYP	MAX	UNIT
Input Power Supply							
1.3.1	Operating current	I_{CC}	$2.8 \leq V_{CC} \leq 5.5$; $I_{SET} = 20\text{mA}$; No Load		0.6	1.0	mA
1.3.2	Current consumption in shutdown mode	I_{SHDN}	$V_{EN/SET} = 0\text{V}$		1.0	2.0	μA
1.3.3	Current matching between channels	$I_{D-Match}$	$I_{SET} = 20\text{mA}$		± 0.9		%
Charge Pump							
1.3.4	Charge pump frequency *	f_{CP}			1.0		MHz
1.3.5	Soft-start time *	T_{SS}			33.0		μs

No.	PARAMETER	SYMBOL	CONDITIONS	MIN	TYP	MAX	UNIT
EN/SET Input (PCC Serial Digital Interface)							
1.3.6	Enable threshold low	V_{EN_L}	$V_{CC} = 2.8V$			0.4	V
1.3.7	Enable threshold high	V_{EN_H}	$V_{CC} = 5.5V$	1.4			V
1.3.8	EN/SET low time	T_{EN/SET_LO}		0.3		75	μs
1.3.9	Minimum EN/SET high time	T_{EN/SET_HI_MIN}		50			ns
1.3.10	Maximum EN/SET high time	T_{EN/SET_HI_MAX}				75	μs
1.3.11	EN/SET off timeout *	T_{OFF}		500			μs
1.3.12	EN/SET latch timeout *	T_{LAT}		500			μs
1.3.13	Internal EN/SET pull-down resistor	R_{EN/SET_DOWN}			500		k Ω

1.4. Typical Performance Graphs

Figure 1.1 Operating Current I_{CC} over Supply Voltage V_{CC} Range (2.8V to 5.5V) at 25°C

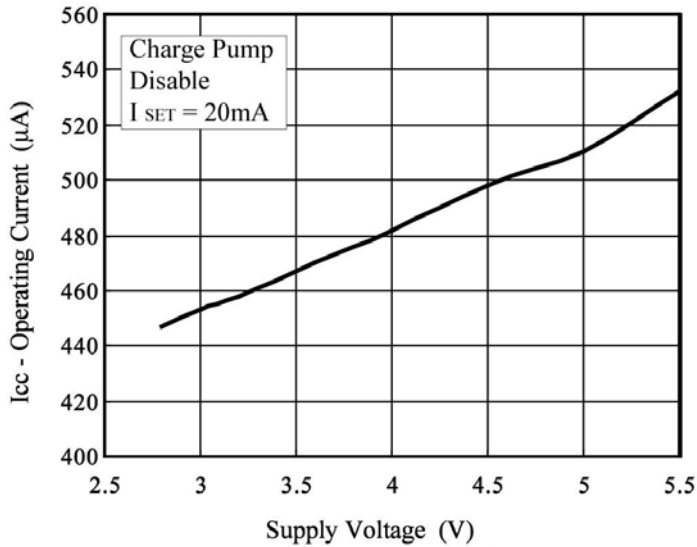

Figure 1.2 LED Current over Supply Voltage V_{CC} Range (2.8V to 5.5V) for Outputs D0:D3 (LED0:LED3)

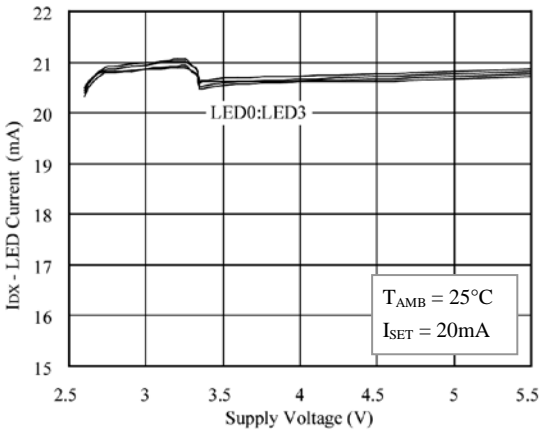

Figure 1.3 Shutdown Current I_{SD} over Supply Voltage V_{CC} Range (2.8V to 5.5V)

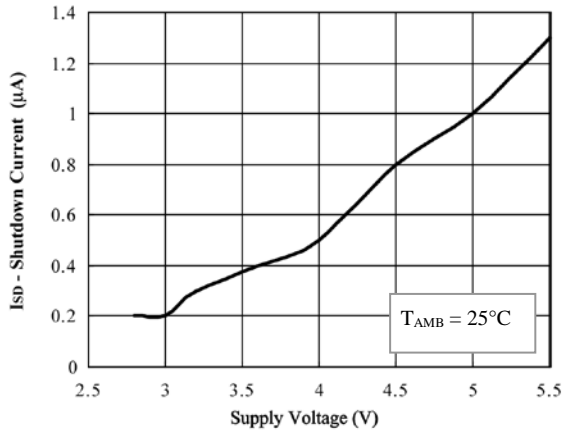

Figure 1.4 Current I_{CC} over Temperature Range ($-40^{\circ}C$ to $+85^{\circ}C$)

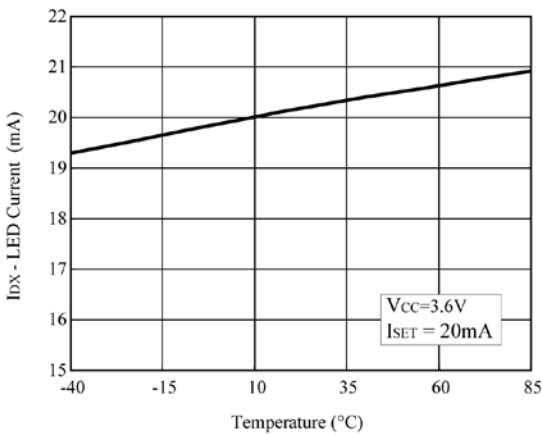
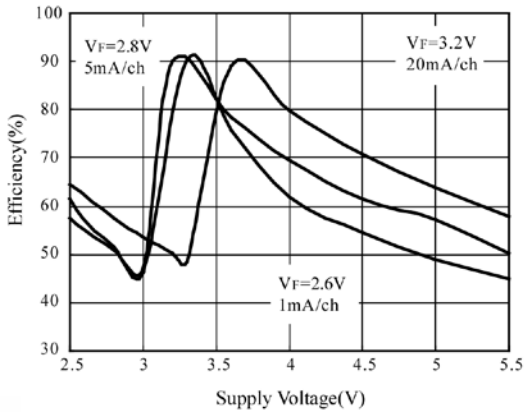
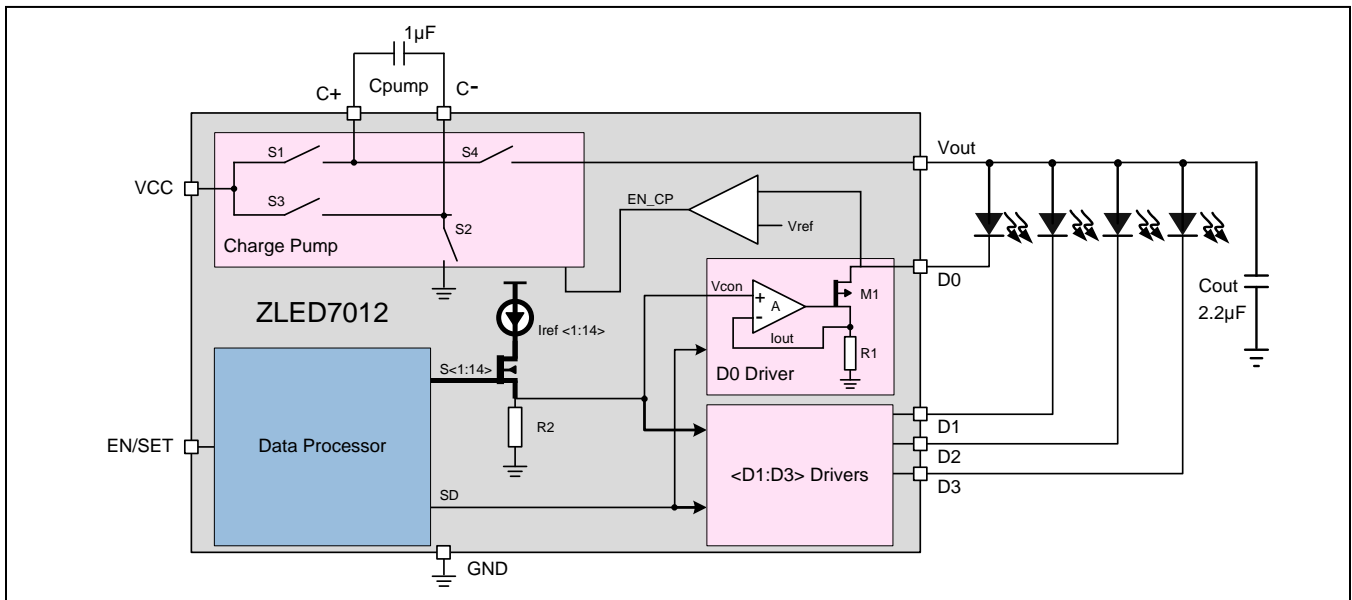

Figure 1.5 Efficiency (%) over the V_{CC} Range (2.8V to 5.5V) at 25°C



2 Circuit Description

2.1. Block Diagram



2.2. ZLED7012 Overview

The ZLED7012 is a low-noise, constant-frequency charge pump DC/DC converter for driving up to four LEDs with constant current at a level controlled via a PCC serial digital interface, providing a uniform and linear brightness progression. Its 20mA (maximum) current output per LED channel is optimal for low-voltage or battery-powered applications, such as portable applications powered by 1-cell lithium batteries. The ZLED7012's current sinks can operate in parallel for driving higher current LEDs. Only a few, small external components are needed for typical applications. The ZLED7012's charge pump operates at a fixed frequency (1MHz typical) with minimal noise and harmonics.

The current sinks [D3:D0] are controlled by the PCC serial data input on the EN/SET pin. Data is written to an internal data register that sets the outputs to one of 14 current levels. The Vout pin provides a shared supply voltage for the LEDs. The capacitor across the C+ and C- pins is the “pump capacitor” used by the charge pump.

2.3. ZLED7012 Soft-Start Feature

The soft-start feature protects against excessive inrush currents during the start-up of the charge pump circuit. This prevents potential transient noise effects that can affect initial performance, especially in battery-operated applications toward the end of the battery life.

2.4. ZLED7012 Low-Current Shutdown Mode

The ZLED7012 enters a low-current shutdown mode whenever its EN/SET input is held low longer than T_{OFF} (500μs minimum). In the low-current shutdown mode, the ZLED7012 draws minimal current (I_{SHDN}=1μA typical, 2μA maximum) and the internal data register that controls output current is reset to 0, which disables the outputs.

2.5. LED Current Control

The ZLED7012's Pulse Count Control (PCC) serial digital interface is used to enable/disable the LED outputs and set the constant current level to one of 14 settings using a nearly logarithmic scale (approximately 1.5dB difference between settings) to provide a linear brightness progression as the current level increases/decreases. See Table 2.1 for the current level settings.

Because [D3:D0] are independent constant current sinks, the voltage at the LED output being driven is determined by the LED's forward voltage (V_F). This enables accurate LED brightness control and matching by the control system.

Table 2.1 Current Output Settings

Data Level	Current Output per Channel (mA)
1	20.0
2	17.0
3	14.0
4	12.0
5	10.0
6	8.6
7	7.0
8	6.0
9	5.0
10	4.2
11	3.6
12	3.0
13	2.4
14	1.8

2.6. PCC Serial Digital Interface

The ZLED7012 detects the rising edges of the control signal input on the EN/SET pin via an internal counter and decodes the signal into one of the 14 current level settings given in Table 2.1. The control signal timing can vary (even during a programming cycle), and its frequency can range from high data rates (e.g., 1MHz) to very low rates (e.g., 15kHz). (Also see section 2.4.) After sending the constant current level code data, the control system holds the EN/SET signal high for time T_{LAT} (500 μ s minimum) so that the ZLED7012 latches the programmed current level code into the data register and the current level becomes active as illustrated in Figure 2.1. The internal counter is then reset to zero to be ready for the next programming cycle. This process is repeated for the next data sent by the control system for subsequent current level programming. See section 2.4 regarding the low-current shutdown mode, which is entered when the EN/SET signal remains low for longer than T_{OFF} (500 μ s minimum).

Figure 2.1 PCC Serial Digital Interface Signal Timing

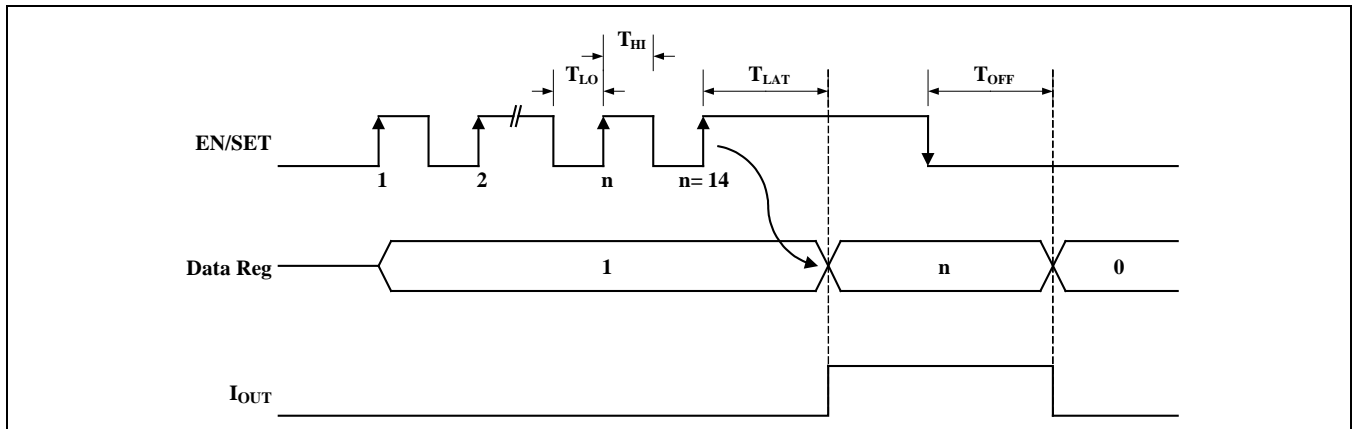

3 Operating Conditions

3.1. RF Noise Reduction

The ZLED7012 charge pump operates at a fixed frequency of 1MHz (typical) to limit noise and harmonics and prevent generation of RF interference by the ZLED7012, which could affect operation of local communication devices, such as cell phones. The soft-start feature also prevents noise transients caused by inrush currents due to charge pump start-up.

The ZLED7012 has significantly lower back-injected noise at the input pin of the charge pump (typically 60mV peak-to-peak), compared to inductor-based DC/DC boost converter solutions for white LED backlight applications (typically 10 times higher).

3.2. ZLED7012 Thermal Protection

The ZLED7012 includes an on-board temperature sensing circuit that shuts down the ZLED7012 and turns off its outputs if the die junction temperature exceeds 160°C (typical).

4 Application Circuit Design

4.1. Applications

The ZLED7012 is designed for white or other color LED applications requiring a controlled LED current that is generated from a varying input voltage. Typical applications include main/sub LCD display backlighting, cell phones (including smartphones), personal digital assistants (PDAs), MP3/MP4 devices, portable media players (PMPs), and general purpose low-voltage industrial applications. See section 4.2.3 for details and requirements for the LEDs.

Figure 4.1 Basic Application Circuit using D2:D0

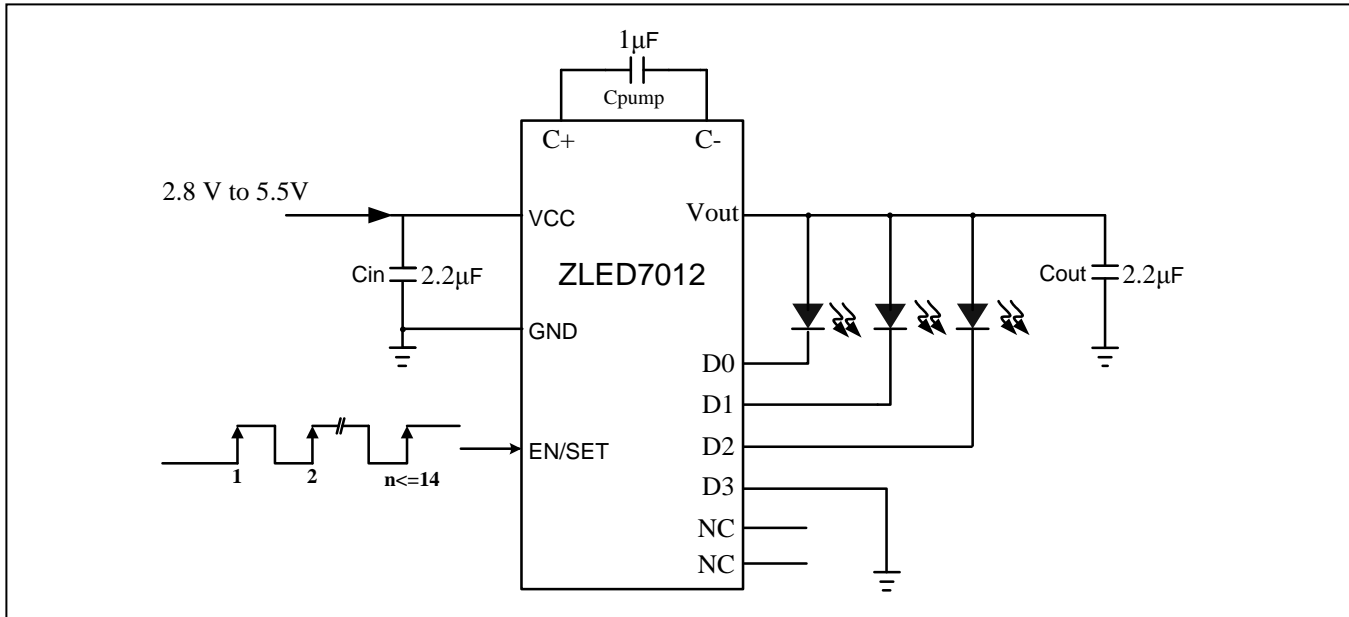

4.2. External Components

4.2.1. External Capacitors Cout and Cin

The values and type of capacitors used for Cin and Cout can affect several circuit parameters including transient performance, turn-on time, and output ripple. Use low equivalent series resistance (ESR) ceramic capacitors (internal resistance < 100mΩ) for best performance, lower costs, and component size reduction. Low ESR capacitors can enable applications at the highest LED forward voltage with the lowest supply voltage. Tantalum and aluminum electrolytic are not generally recommended because the ESR is typically in the range of several ohms.

Note: The recommended starting value when determining the optimal value for Cout is 2.2µF. There is often a design trade-off between low ESR ratings and smaller size because physically larger ceramic capacitors usually have a relatively lower ESR, which can improve the operating range of the circuit.

Cin is a bypass capacitor ($\geq 2.2\mu\text{F}$) essential to proper operation because it must deliver the dynamic current for the charge pump.

4.2.2. External Pump Capacitor

The external pump capacitor Cpump connected between the C+ and C- pins is an essential part of the ZLED7012's internal charge pump circuit. Because the ZLED7012 operates at a constant charge-pump frequency of 1MHz (typical), it is important that the pump capacitance is greater than 0.47µF so it can transfer enough charge each cycle to supply sufficient load current. To reduce voltage fluctuations on the supply line, do not use a value for the pump capacitor that is greater than the bypass capacitor, Cin.

Select a pump capacitor value in the range of 0.47 μ F to 2.2 μ F depending on output current requirements; 1 μ F is recommended for most applications. When designing the circuit to operate at high levels of output current, choose a higher value of capacitance; low output currents do not require a large pump capacitor. As with Cin and Cout, low ESR ceramic capacitors are recommended for the pump capacitor. See section 4.2.1 for a discussion of low ESR capacitors.

4.2.3. LEDs

The ZLED7012's low dropout current sinks are capable of driving most types of LEDs with forward voltages as high as 4.7V at full current with a Vcc input supply of 2.8V to 5.5V. High-current LEDs can be driven by using any of the D3:D0 pins in parallel.

The brightness of the LEDs being driven will match despite any variations in the forward voltage (V_F) of the individual LEDs because the [D3:D0] output current sinks are matched with negligible voltage dependence (see section 1.3 for specifications).

4.3. Unused LED Driver Pins

LED driver pin D0 must always be used. If any of the LED driver pins [D1:D3] are unused, disable the pin(s) by connecting them to ground to avoid noise coupling.

5 ESD Protection

From each I/O or VCC pin to GND, there is an ESD protection of $\geq \pm 3000V$. Between the I/O pins, there is an ESD protection of $\geq \pm 1000V$ according the Human Body Model (HBM). The ESD test follows the Human Body Model with 1.5 k Ω /100 pF based on MIL 883-G, Method 3015.7.

6 Pin Configuration and Package

Figure 6.1 Pin Configuration ZLED7012 – Top View

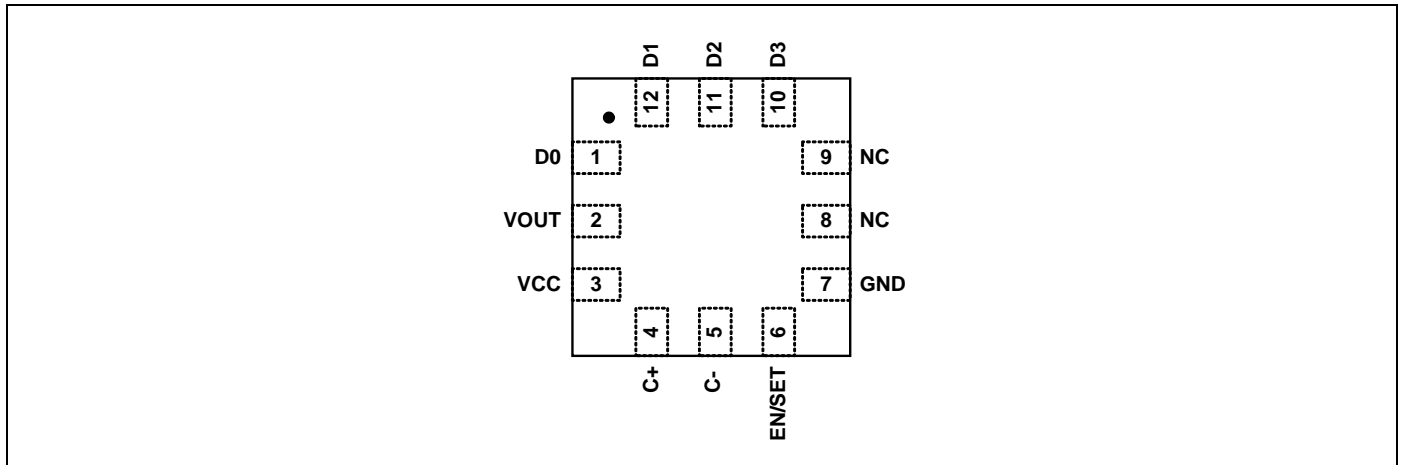

Table 6.1 Layout Requirements and Pin Descriptions—12-pin UTQFN Package

Pin Name	No.	Description
D0	1	LED output channel; pin must be used.
Vout	2	Charge pump output that drives load circuits; a 2.2μF (typical) capacitor must be connected from Vout to GND pin.
Vcc	3	Power supply input; a 2.2μF (minimum) bypass capacitor must be connected from Vcc to GND pin.
C+	4	Positive terminal of external pump capacitor.
C-	5	Negative terminal of external pump capacitor.
EN/SET	6	PCC serial input for enabling/disabling LEDs and setting current levels.
GND	7	Ground.
NC	8	No connection.
NC	9	No connection.
D3	10	LED output; if not used, connect to ground to avoid noise coupling.
D2	11	LED output; if not used, connect to ground to avoid noise coupling.
D1	12	LED output; if not used, connect to ground to avoid noise coupling.

Figure 6.2 UTQFN-12 Package Drawing

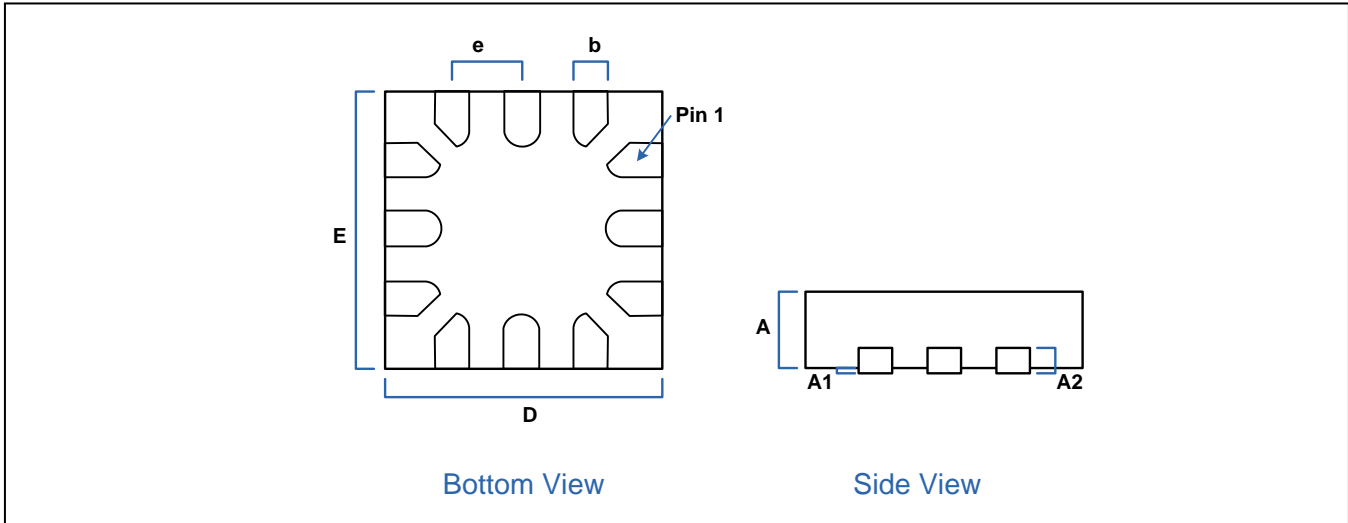

Table 6.2 UTQFN-12 Package Dimensions

Symbol	Dimension (mm)			Symbol	Dimension (mm)		
	Min	Nom	Max		Min	Nom	Max
A	0.50	0.55	0.60	D	1.95	2.00	2.05
A1	0.00	--	0.05	E	1.95	2.00	2.05
A2	0.25			e	0.50		
				b	0.20	0.25	0.30

7 Ordering Information

Product Sales Code	Description	Package
ZLED7012ZI1R	ZLED7012 – Low-Voltage Four-Channel LED Driver	UTQFN12 (2x2)mm, Tape & Reel
ZLED7012KIT-E1	ZLED7012 Evaluation Board	Kit

8 Glossary

Term	Description
EMI	Electromagnetic Interference
ESR	Equivalent Series Resistance: a capacitor parameter affected by characteristics such as component composition, size, leads, internal connections, and temperature
PCC	Pulse Count Control: a serial digital interface

9 Document Revision History

Revision	Date	Description
1.0	November 9, 2010	Official Release
	April 20, 2016	Changed to IDT branding.

IMPORTANT NOTICE AND DISCLAIMER

RENESAS ELECTRONICS CORPORATION AND ITS SUBSIDIARIES (“RENESAS”) PROVIDES TECHNICAL SPECIFICATIONS AND RELIABILITY DATA (INCLUDING DATASHEETS), DESIGN RESOURCES (INCLUDING REFERENCE DESIGNS), APPLICATION OR OTHER DESIGN ADVICE, WEB TOOLS, SAFETY INFORMATION, AND OTHER RESOURCES “AS IS” AND WITH ALL FAULTS, AND DISCLAIMS ALL WARRANTIES, EXPRESS OR IMPLIED, INCLUDING, WITHOUT LIMITATION, ANY IMPLIED WARRANTIES OF MERCHANTABILITY, FITNESS FOR A PARTICULAR PURPOSE, OR NON-INFRINGEMENT OF THIRD-PARTY INTELLECTUAL PROPERTY RIGHTS.

These resources are intended for developers who are designing with Renesas products. You are solely responsible for (1) selecting the appropriate products for your application, (2) designing, validating, and testing your application, and (3) ensuring your application meets applicable standards, and any other safety, security, or other requirements. These resources are subject to change without notice. Renesas grants you permission to use these resources only to develop an application that uses Renesas products. Other reproduction or use of these resources is strictly prohibited. No license is granted to any other Renesas intellectual property or to any third-party intellectual property. Renesas disclaims responsibility for, and you will fully indemnify Renesas and its representatives against, any claims, damages, costs, losses, or liabilities arising from your use of these resources. Renesas' products are provided only subject to Renesas' Terms and Conditions of Sale or other applicable terms agreed to in writing. No use of any Renesas resources expands or otherwise alters any applicable warranties or warranty disclaimers for these products.

(Disclaimer Rev.1.01)

Corporate Headquarters

TOYOSU FORESIA, 3-2-24 Toyosu,
Koto-ku, Tokyo 135-0061, Japan
www.renesas.com

Trademarks

Renesas and the Renesas logo are trademarks of Renesas Electronics Corporation. All trademarks and registered trademarks are the property of their respective owners.

Contact Information

For further information on a product, technology, the most up-to-date version of a document, or your nearest sales office, please visit www.renesas.com/contact-us/.