

RZ/Five Group

User's Manual: Hardware

Renesas Microprocessor
RZ Family / RZ/G Series

All information contained in these materials, including products and product specifications, represents information on the product at the time of publication and is subject to change by Renesas Electronics Corp. without notice. Please review the latest information published by Renesas Electronics Corp. through various means, including the Renesas Electronics Corp. website (<http://www.renesas.com>).

Notice

1. Descriptions of circuits, software and other related information in this document are provided only to illustrate the operation of semiconductor products and application examples. You are fully responsible for the incorporation or any other use of the circuits, software, and information in the design of your product or system. Renesas Electronics disclaims any and all liability for any losses and damages incurred by you or third parties arising from the use of these circuits, software, or information.
2. Renesas Electronics hereby expressly disclaims any warranties against and liability for infringement or any other claims involving patents, copyrights, or other intellectual property rights of third parties, by or arising from the use of Renesas Electronics products or technical information described in this document, including but not limited to, the product data, drawings, charts, programs, algorithms, and application examples.
3. No license, express, implied or otherwise, is granted hereby under any patents, copyrights or other intellectual property rights of Renesas Electronics or others.
4. You shall be responsible for determining what licenses are required from any third parties, and obtaining such licenses for the lawful import, export, manufacture, sales, utilization, distribution or other disposal of any products incorporating Renesas Electronics products, if required.
5. You shall not alter, modify, copy, or reverse engineer any Renesas Electronics product, whether in whole or in part. Renesas Electronics disclaims any and all liability for any losses or damages incurred by you or third parties arising from such alteration, modification, copying or reverse engineering.
6. Renesas Electronics products are classified according to the following two quality grades: "Standard" and "High Quality". The intended applications for each Renesas Electronics product depends on the product's quality grade, as indicated below.

"Standard": Computers; office equipment; communications equipment; test and measurement equipment; audio and visual equipment; home electronic appliances; machine tools; personal electronic equipment; industrial robots; etc.

"High Quality": Transportation equipment (automobiles, trains, ships, etc.); traffic control (traffic lights); large-scale communication equipment; key financial terminal systems; safety control equipment; etc.

Unless expressly designated as a high reliability product or a product for harsh environments in a Renesas Electronics data sheet or other Renesas Electronics document, Renesas Electronics products are not intended or authorized for use in products or systems that may pose a direct threat to human life or bodily injury (artificial life support devices or systems; surgical implantations; etc.), or may cause serious property damage (space system; undersea repeaters; nuclear power control systems; aircraft control systems; key plant systems; military equipment; etc.). Renesas Electronics disclaims any and all liability for any damages or losses incurred by you or any third parties arising from the use of any Renesas Electronics product that is inconsistent with any Renesas Electronics data sheet, user's manual or other Renesas Electronics document.
7. No semiconductor product is absolutely secure. Notwithstanding any security measures or features that may be implemented in Renesas Electronics hardware or software products, Renesas Electronics shall have absolutely no liability arising out of any vulnerability or security breach, including but not limited to any unauthorized access to or use of a Renesas Electronics product or a system that uses a Renesas Electronics product. RENESAS ELECTRONICS DOES NOT WARRANT OR GUARANTEE THAT RENESAS ELECTRONICS PRODUCTS, OR ANY SYSTEMS CREATED USING RENESAS ELECTRONICS PRODUCTS WILL BE INVULNERABLE OR FREE FROM CORRUPTION, ATTACK, VIRUSES, INTERFERENCE, HACKING, DATA LOSS OR THEFT, OR OTHER SECURITY INTRUSION ("Vulnerability Issues"). RENESAS ELECTRONICS DISCLAIMS ANY AND ALL RESPONSIBILITY OR LIABILITY ARISING FROM OR RELATED TO ANY VULNERABILITY ISSUES. FURTHERMORE, TO THE EXTENT PERMITTED BY APPLICABLE LAW, RENESAS ELECTRONICS DISCLAIMS ANY AND ALL WARRANTIES, EXPRESS OR IMPLIED, WITH RESPECT TO THIS DOCUMENT AND ANY RELATED OR ACCOMPANYING SOFTWARE OR HARDWARE, INCLUDING BUT NOT LIMITED TO THE IMPLIED WARRANTIES OF MERCHANTABILITY, OR FITNESS FOR A PARTICULAR PURPOSE.
8. When using Renesas Electronics products, refer to the latest product information (data sheets, user's manuals, application notes, "General Notes for Handling and Using Semiconductor Devices" in the reliability handbook, etc.), and ensure that usage conditions are within the ranges specified by Renesas Electronics with respect to maximum ratings, operating power supply voltage range, heat dissipation characteristics, installation, etc. Renesas Electronics disclaims any and all liability for any malfunctions, failure or accident arising out of the use of Renesas Electronics products outside of such specified ranges.
9. Although Renesas Electronics endeavors to improve the quality and reliability of Renesas Electronics products, semiconductor products have specific characteristics, such as the occurrence of failure at a certain rate and malfunctions under certain use conditions. Unless designated as a high reliability product or a product for harsh environments in a Renesas Electronics data sheet or other Renesas Electronics document, Renesas Electronics products are not subject to radiation resistance design. You are responsible for implementing safety measures to guard against the possibility of bodily injury, injury or damage caused by fire, and/or danger to the public in the event of a failure or malfunction of Renesas Electronics products, such as safety design for hardware and software, including but not limited to redundancy, fire control and malfunction prevention, appropriate treatment for aging degradation or any other appropriate measures. Because the evaluation of microcomputer software alone is very difficult and impractical, you are responsible for evaluating the safety of the final products or systems manufactured by you.
10. Please contact a Renesas Electronics sales office for details as to environmental matters such as the environmental compatibility of each Renesas Electronics product. You are responsible for carefully and sufficiently investigating applicable laws and regulations that regulate the inclusion or use of controlled substances, including without limitation, the EU RoHS Directive, and using Renesas Electronics products in compliance with all these applicable laws and regulations. Renesas Electronics disclaims any and all liability for damages or losses occurring as a result of your noncompliance with applicable laws and regulations.
11. Renesas Electronics products and technologies shall not be used for or incorporated into any products or systems whose manufacture, use, or sale is prohibited under any applicable domestic or foreign laws or regulations. You shall comply with any applicable export control laws and regulations promulgated and administered by the governments of any countries asserting jurisdiction over the parties or transactions.
12. It is the responsibility of the buyer or distributor of Renesas Electronics products, or any other party who distributes, disposes of, or otherwise sells or transfers the product to a third party, to notify such third party in advance of the contents and conditions set forth in this document.
13. This document shall not be reprinted, reproduced or duplicated in any form, in whole or in part, without prior written consent of Renesas Electronics.
14. Please contact a Renesas Electronics sales office if you have any questions regarding the information contained in this document or Renesas Electronics products.

(Note1) "Renesas Electronics" as used in this document means Renesas Electronics Corporation and also includes its directly or indirectly controlled subsidiaries.

(Note2) "Renesas Electronics product(s)" means any product developed or manufactured by or for Renesas Electronics.

(Rev.5.0-1 October 2020)

Corporate Headquarters

TOYOSU FORESIA, 3-2-24 Toyosu,
Koto-ku, Tokyo 135-0061, Japan
www.renesas.com

Contact information

For further information on a product, technology, the most up-to-date version of a document, or your nearest sales office, please visit:
www.renesas.com/contact/

Trademarks

Renesas and the Renesas logo are trademarks of Renesas Electronics Corporation. All trademarks and registered trademarks are the property of their respective owners.

Trademarks (continued)

AndesCore™ AX45MP is a trademark owned by Andes Technology Corporation.

AMBA®: AMBA is a registered trademark of Arm Limited.

CoreLink™: CoreLink is a trademark of Arm Limited.

TrustZone®: TrustZone is a registered trademark of Arm Limited.

eMMC™: eMMC is a trademark of MultiMediaCard Association.

General Precautions in the Handling of Microprocessing Unit and Microcontroller Unit Products

The following usage notes are applicable to all Microprocessing unit and Microcontroller unit products from Renesas. For detailed usage notes on the products covered by this document, refer to the relevant sections of the document as well as any technical updates that have been issued for the products.

1. Precaution against Electrostatic Discharge (ESD)

A strong electrical field, when exposed to a CMOS device, can cause destruction of the gate oxide and ultimately degrade the device operation. Steps must be taken to stop the generation of static electricity as much as possible, and quickly dissipate it when it occurs. Environmental control must be adequate. When it is dry, a humidifier should be used. This is recommended to avoid using insulators that can easily build up static electricity.

Semiconductor devices must be stored and transported in an anti-static container, static shielding bag or conductive material. All test and measurement tools including work benches and floors must be grounded. The operator must also be grounded using a wrist strap. Semiconductor devices must not be touched with bare hands. Similar precautions must be taken for printed circuit boards with mounted semiconductor devices.

2. Processing at power-on

The state of the product is undefined at the time when power is supplied. The states of internal circuits in the LSI are indeterminate and the states of register settings and pins are undefined at the time when power is supplied. In a finished product where the reset signal is applied to the external reset pin, the states of pins are not guaranteed from the time when power is supplied until the reset process is completed. In a similar way, the states of pins in a product that is reset by an on-chip power-on reset function are not guaranteed from the time when power is supplied until the power reaches the level at which resetting is specified.

3. Input of signal during power-off state

Do not input signals or an I/O pull-up power supply while the device is powered off. The current injection that results from input of such a signal or I/O pull-up power supply may cause malfunction and the abnormal current that passes in the device at this time may cause degradation of internal elements. Follow the guideline for input signal during power-off state as described in your product documentation.

4. Handling of unused pins

Handle unused pins in accordance with the directions given under handling of unused pins in the manual. The input pins of CMOS products are generally in the high-impedance state. In operation with an unused pin in the open-circuit state, extra electromagnetic noise is induced in the vicinity of the LSI, an associated shoot-through current flows internally, and malfunctions occur due to the false recognition of the pin state as an input signal become possible.

5. Clock signals

After applying a reset, only release the reset line after the operating clock signal becomes stable. When switching the clock signal during program execution, wait until the target clock signal is stabilized. When the clock signal is generated with an external resonator or from an external oscillator during a reset, ensure that the reset line is only released after full stabilization of the clock signal. Additionally, when switching to a clock signal produced with an external resonator or by an external oscillator while program execution is in progress, wait until the target clock signal is stable.

6. Voltage application waveform at input pin

Waveform distortion due to input noise or a reflected wave may cause malfunction. If the input of the CMOS device stays in the area between V_{IL} (Max.) and V_{IH} (Min.) due to noise, for example, the device may malfunction. Take care to prevent chattering noise from entering the device when the input level is fixed, and also in the transition period when the input level passes through the area between V_{IL} (Max.) and V_{IH} (Min.).

7. Prohibition of access to reserved addresses

Access to reserved addresses is prohibited. The reserved addresses are provided for possible future expansion of functions. Do not access these addresses as the correct operation of the LSI is not guaranteed.

8. Differences between products

Before changing from one product to another, for example to a product with a different part number, confirm that the change will not lead to problems. The characteristics of a microprocessing unit or microcontroller unit products in the same group but having a different part number might differ in terms of internal memory capacity, layout pattern, and other factors, which can affect the ranges of electrical characteristics, such as characteristic values, operating margins, immunity to noise, and amount of radiated noise. When changing to a product with a different part number, implement a system-evaluation test for the given product.

Table of Contents

1.	Overview	51
1.1	Introduction.....	51
1.2	List of Specifications	52
1.2.1	CPU Core	52
1.2.2	CPU Peripheral.....	53
1.2.3	Internal Memory.....	53
1.2.4	External Memory Interface	54
1.2.5	Sound Interface	55
1.2.6	Storage and Network.....	55
1.2.7	Timer	56
1.2.8	Peripheral Module	57
1.2.9	Security.....	57
1.2.10	Analog	58
1.2.11	Others.....	58
1.2.12	Power Supply Voltage	58
1.2.13	Temperature Range	58
1.2.14	Quality level.....	59
1.2.15	Package.....	59
1.3	Product Lineup	60
1.4	Pin	61
1.4.1	Pin Assignment.....	61
1.4.2	External Pins and Multiplexed Functional Pins	61
2.	System CPU AX45MP	62
2.1	Features	62
2.2	Reset.....	64
2.2.1	Cold Reset.....	64
2.3	Interrupt.....	65
2.4	Low Power Consumption Mode	65
2.4.1	AX45MP Sleep Mode	65
2.5	Note.....	65
2.5.1	L2C Control Register	65
4.	Boot Mode	66
4.1	Overview	66
4.2	Operation.....	67
4.2.1	Boot Mode 0 (eSD).....	67
4.2.1.1	External Connections	68
4.2.1.2	Overview of Operation	69
4.2.1.3	Operation of Booting from eSD	69
4.2.1.4	Allocation of the Loader Programs in the eSD Device	70

4.2.1.5	Note	74
4.2.2	Boot Mode 1 (1.8-V eMMC)	75
4.2.2.1	External Connections	76
4.2.2.2	Overview of Operation	77
4.2.2.3	Operation of Booting from 1.8-V eMMC	77
4.2.2.4	Allocation of the Loader Program in the eMMC Device	78
4.2.2.5	Alternative Boot Operation	80
4.2.2.6	Notes	81
4.2.3	Boot Mode 2 (3.3-V eMMC)	82
4.2.3.1	External Connections	83
4.2.3.2	Overview of Operation	84
4.2.3.3	Operation of Booting from 3.3-V eMMC	84
4.2.3.4	Notes	84
4.2.4	Boot Mode 3 (1.8-V Single or Quad Serial Flash Memory).....	85
4.2.4.1	External Connections	86
4.2.4.2	Overview of Operation	87
4.2.4.3	Operation of Booting from 1.8-V Serial Flash Memory	87
4.2.4.4	Allocation of the Loader Program in the Serial Flash Memory.....	88
4.2.5	Boot Mode 4 (3.3-V Single or Quad Serial Flash Memory).....	90
4.2.5.1	External Connections	91
4.2.5.2	Overview of Operation	92
4.2.5.3	Operation of Booting from 3.3-V Serial Flash Memory	92
4.2.5.4	Note	92
4.2.6	Boot Mode 5 (SCIF Downloading).....	93
4.2.6.1	External Connections	93
4.2.6.2	Overview of Operation	94
4.2.6.3	Operation of Booting through SCIF Downloading	95
4.2.6.4	Allocation of the Loader Program for SCIF Downloading	96
4.2.6.5	Note	97
5.	LSI Internal Bus	98
5.1	Overview	98
5.1.1	Features	98
5.1.2	Block Diagram of LSI Internal Bus	98
5.2	Area Maps	100
5.2.1	Overall Address Space.....	100
5.3	Accessible Areas.....	104
5.4	Bus System Control	106
5.4.1	Security Control	106
5.4.1.1	Re-Setting the Security Attribute Output from Bus Masters	106
5.4.1.2	Determining the Security Levels of Bus Slaves.....	108
5.4.2	Address Translation	112
5.4.2.1	34-Bit Address Space Access	112
5.4.3	Bus Error Interrupt Generation	114
6.	System Controller (SYSC).....	115
6.1	Overview	115
6.1.1	Features	115

6.1.2	Block Diagram of SYSC	116
6.2	Register Configuration	117
6.3	Register Descriptions	119
6.3.1	Master Access Control Register 0 (SYS_MSTACCCTL0).....	119
6.3.2	Master Access Control Register 1 (SYS_MSTACCCTL1).....	121
6.3.3	Master Access Control Register 2 (SYS_MSTACCCTL2).....	124
6.3.4	Slave Access Control Register 0 (SYS_SLVACCCTL0).....	126
6.3.5	Slave Access Control Register 1 (SYS_SLVACCCTL1).....	127
6.3.6	Slave Access Control Register 2 (SYS_SLVACCCTL2).....	129
6.3.7	Slave Access Control Register 3 (SYS_SLVACCCTL3).....	130
6.3.8	Slave Access Control Register 4 (SYS_SLVACCCTL4).....	132
6.3.9	Slave Access Control Register 5 (SYS_SLVACCCTL5).....	133
6.3.10	Slave Access Control Register 6 (SYS_SLVACCCTL6).....	134
6.3.11	Slave Access Control Register 7 (SYS_SLVACCCTL7).....	134
6.3.12	Slave Access Control Register 8 (SYS_SLVACCCTL8).....	135
6.3.13	Slave Access Control Register 10 (SYS_SLVACCCTL10).....	135
6.3.14	Slave Access Control Register 12 (SYS_SLVACCCTL12).....	136
6.3.15	Slave Access Control Register 13 (SYS_SLVACCCTL13).....	136
6.3.16	Slave Access Control Register 14 (SYS_SLVACCCTL14).....	137
6.3.17	ECCRAM0 ECC Setting Register (SYS_RAM0_ECC)	138
6.3.18	ECCRAM0 Access Control Register (SYS_RAM0_EN)	138
6.3.19	ECCRAM1 ECC Setting Register (SYS_RAM1_ECC)	139
6.3.20	ECCRAM1 Access Control Register (SYS_RAM1_EN)	139
6.3.21	WDT0 Control Register (SYS_WDT0_CTRL).....	140
6.3.22	GEther0 Config Register (SYS_GETH0_CFG).....	141
6.3.23	GEther1 Config Register (SYS_GETH1_CFG).....	142
6.3.24	I2C0 Config Register (SYS_I2C0_CFG)	142
6.3.25	I2C1 Config Register (SYS_I2C1_CFG)	143
6.3.26	I2C2 Config Register (SYS_I2C2_CFG)	143
6.3.27	I2C3 Config Register (SYS_I2C3_CFG)	144
6.3.28	AX45MP Core0 Reset Vector Address Low Configuration Register (SYS_AX45MP_CFG_RVAL0).....	145
6.3.29	AX45MP Core0 Reset Vector Address High Configuration Register (SYS_AX45MP_CFG_RVAH0).....	145
6.3.30	AX45MP status Register (SYS_AX45MP_STATUS).....	146
6.3.31	LSI Mode Signal Register (SYS_LSI_MODE).....	147
6.3.32	LSI Device ID Register (SYS_LSI_DEVID).....	148
6.3.33	LSI Product Register (SYS_LSI_PRR)	149
6.3.34	Address Offset Register0 (SYS_AOF0)	150
6.3.35	Address Offset Register1 (SYS_AOF1)	151
6.3.36	Address Offset Register2 (SYS_AOF2).....	152

6.3.37	Address Offset Register3 (SYS_AOF3)	153
6.3.38	Address Offset Register6 (SYS_AOF6)	154
6.3.39	General Register0 (SYS_GPREG_0)	155
6.3.40	General Register1 (SYS_GPREG_1)	155
6.3.41	General Register2 (SYS_GPREG_2)	156
6.3.42	General Register3 (SYS_GPREG_3)	156
6.4	Operation	157
6.4.1	External Terminal State Capture Function	157
6.4.2	WDT Stop Control Function	157
7.	Clock Pulse Generator (CPG)	158
7.1	Features	158
7.1.1	Overview	158
7.1.2	CPG configuration	159
7.1.3	Pin description	160
7.1.4	Clock	161
7.1.4.1	Clock System Diagram	161
7.1.4.2	Clock List	163
7.2	Register description	164
7.2.1	Register attributes	164
7.2.2	Register classification	164
7.2.3	Register configuration	165
7.2.4	Register Descriptions	169
7.2.4.1	PLL _n (SSCG) Standby Control Register (CPG_SAMPPLL _n _STBY) (n = 1, 4, or 6)	169
7.2.4.2	PLL _n (SSCG) Output Clock Setting Register 1 (CPG_SAMPPLL _n _CLK1) (n = 1, 4, or 6)	171
7.2.4.3	PLL _n (SSCG) Output Clock Setting Register 2 (CPG_SAMPPLL _n _CLK2) (n = 1, 4, or 6)	173
7.2.4.4	PLL _n (SSCG) Monitor Register (CPG_SAMPPLL _n _MON) (n = 1, 4, or 6)	176
7.2.4.5	PLL1_SEL_SETTING Register (CPG_PLL1_SETTING)	177
7.2.4.6	CPG_OTPPLL0_MON Register (CPG_OTPPLL0_MON)	178
7.2.4.7	CPG_OTPPLL1_MON Register (CPG_OTPPLL1_MON)	179
7.2.4.8	CPG_OTPPLL2_MON Register (CPG_OTPPLL2_MON)	180
7.2.4.9	PLL _n (SSCG) Monitor Register (CPG_SIPLL _n _MON) (n = 2, 3)	181
7.2.4.10	Division Ratio Setting (PLL1) Register (CPG_PL1_DDIV)	182
7.2.4.11	Division Ratio Setting (PLL2) Register (CPG_PL2_DDIV)	183
7.2.4.12	Division Ratio Setting (PLL3A) Register (CPG_PL3A_DDIV)	185
7.2.4.13	Division Ratio Setting (PLL3B) Register (CPG_PL3B_DDIV)	187
7.2.4.14	Source Clock Setting (SDHI) Register (CPG_PL2SDHI_DSEL)	188
7.2.4.15	Source Clock Setting (DDR) Register (CPG_PL4_DSEL)	189
7.2.4.16	Clock Status Monitor Register (CPG_CLKSTATUS)	190
7.2.4.17	Source Clock Setting Register (CPG_PL3_SSEL)	192
7.2.4.18	Clock Control Register ACPU (CPG_CLKON_SRAM_ACPU)	193
7.2.4.19	Clock Control Register MCPU (CPG_CLKON_SRAM_MCPU)	194
7.2.4.20	Clock Control Register IAX45 (CPG_CLKON_IAX45)	195
7.2.4.21	Clock Control Register SYC (CPG_CLKON_SYC)	196
7.2.4.22	Clock Control Register DMAC_REG (CPG_CLKON_DMAC_REG)	197

7.2.4.23	Clock Control Register GTM (CPG_CLKON_GTM).....	198
7.2.4.24	Clock Control Register MTU (CPG_CLKON_MTU)	199
7.2.4.25	Clock Control Register POE3 (CPG_CLKON_POE3).....	200
7.2.4.26	Clock Control Register WDT (CPG_CLKON_WDT)	201
7.2.4.27	Clock Control Register DDR (CPG_CLKON_DDR)	203
7.2.4.28	Clock Control Register SPI_MULTI (CPG_CLKON_SPI_MULTI)	204
7.2.4.29	Clock Control Register SDHI (CPG_CLKON_SDHI).....	205
7.2.4.30	Clock Control Register SSI (CPG_CLKON_SSI)	207
7.2.4.31	Clock Control Register USB (CPG_CLKON_USB).....	209
7.2.4.32	Clock Control Register ETH (CPG_CLKON_ETH)	210
7.2.4.33	Clock Control Register I2C (CPG_CLKON_I2C).....	211
7.2.4.34	Clock Control Register SCIF (CPG_CLKON_SCIF)	212
7.2.4.35	Clock Control Register SCI (CPG_CLKON_SCI).....	214
7.2.4.36	Clock Control Register IRDA (CPG_CLKON_IRDA).....	215
7.2.4.37	Clock Control Register RSPI (CPG_CLKON_RSPI).....	216
7.2.4.38	Clock Control Register CANFD (CPG_CLKON_CANFD).....	217
7.2.4.39	Clock Control Register GPIO (CPG_CLKON_GPIO).....	218
7.2.4.40	Clock Control Register ADC (CPG_CLKON_ADC).....	219
7.2.4.41	Clock Control Register TSU (CPG_CLKON_TSU)	220
7.2.4.42	Clock Control Register AXI_TZCDDR (CPG_CLKON_AXI_TZCDDR)	221
7.2.4.43	Clock Control Register AX45MP (CPG_CLKON_AX45MP)	222
7.2.4.44	Clock Control Register NCEPLDM (CPG_CLKON_NCEPLDM)	223
7.2.4.45	Clock Control Register NCEPLMT (CPG_CLKON_NCEPLMT)	224
7.2.4.46	Clock Control Register NCEPLIC (CPG_CLKON_NCEPLIC)	225
7.2.4.47	Clock Monitor Register SRAM_ACPU (CPG_CLKMON_SRAM_ACPU)	226
7.2.4.48	Clock Monitor Register SRAM_MCPU (CPG_CLKMON_SRAM_MCPU).....	227
7.2.4.49	Clock Monitor Register IAX45 (CPG_CLKMON_IAX45).....	228
7.2.4.50	Clock Monitor Register SYC (CPG_CLKMON_SYC).....	229
7.2.4.51	Clock Monitor Register DMAC_REG (CPG_CLKMON_DMAL_REG)	230
7.2.4.52	Clock Monitor Register GTM (CPG_CLKMON_GTM)	231
7.2.4.53	Clock Monitor Register MTU (CPG_CLKMON_MTU).....	232
7.2.4.54	Clock Monitor Register POE3 (CPG_CLKMON_POE3).....	233
7.2.4.55	Clock Monitor Register WDT (CPG_CLKMON_WDT).....	234
7.2.4.56	Clock Monitor Register DDR (CPG_CLKMON_DDR).....	235
7.2.4.57	Clock Monitor Register SPI_MULTI (CPG_CLKMON_SPI_MULTI).....	236
7.2.4.58	Clock Monitor Register SDHI (CPG_CLKMON_SDHI)	237
7.2.4.59	Clock Monitor Register SSI (CPG_CLKMON_SSI).....	238
7.2.4.60	Clock Monitor Register USB (CPG_CLKMON_USB).....	239
7.2.4.61	Clock Monitor Register ETH (CPG_CLKMON_ETH).....	240
7.2.4.62	Clock Monitor Register I2C (CPG_CLKMON_I2C)	241
7.2.4.63	Clock Monitor Register SCIF (CPG_CLKMON_SCIF).....	242
7.2.4.64	Clock Monitor Register SCI (CPG_CLKMON_SCI)	243
7.2.4.65	Clock Monitor Register IRDA (CPG_CLKMON_IRDA).....	244
7.2.4.66	Clock Monitor Register RSPI (CPG_CLKMON_RSPI).....	245
7.2.4.67	Clock Monitor Register CANFD (CPG_CLKMON_CANFD)	246
7.2.4.68	Clock Monitor Register GPIO (CPG_CLKMON_GPIO)	247
7.2.4.69	Clock Monitor Register ADC (CPG_CLKMON_ADC).....	248
7.2.4.70	Clock Monitor Register AX45MP (CPG_CLKMON_AX45MP).....	249
7.2.4.71	Clock Monitor Register NCEPLDM (CPG_CLKMON_NCEPLDM).....	250
7.2.4.72	Clock Monitor Register NCEPLMT (CPG_CLKMON_NCEPLMT).....	251
7.2.4.73	Clock Monitor Register NCEPLIC (CPG_CLKMON_NCEPLIC).....	252
7.2.4.74	Clock Monitor Register TSU (CPG_CLKMON_TSU).....	253
7.2.4.75	Clock Monitor Register AXI_TZCDDR (CPG_CLKMON_AXI_TZCDDR).....	254

7.2.4.76	Reset Control Register SRAM_ACPU (CPG_RST_SRAM_ACPU).....	255
7.2.4.77	Reset Control Register SRAM_MCPU (CPG_RST_SRAM_MCPU)	256
7.2.4.78	Reset Control Register IAX45 (CPG_RST_IAX45).....	257
7.2.4.79	Reset Control Register SYC (CPG_RST_SYC).....	258
7.2.4.80	Reset Control Register DMAC (CPG_RST_DMAC)	259
7.2.4.81	Reset Control Register GTM (CPG_RST_GTM).....	260
7.2.4.82	Reset Control Register MTU (CPG_RST_MTU).....	261
7.2.4.83	Reset Control Register POE3 (CPG_RST_POE3)	262
7.2.4.84	Reset Control Register WDT (CPG_RST_WDT)	263
7.2.4.85	Reset Control Register DDR (CPG_RST_DDR).....	264
7.2.4.86	Reset Control Register SPI (CPG_RST_SPI).....	266
7.2.4.87	Reset Control Register SDHI (CPG_RST_SDHI)	267
7.2.4.88	Reset Control Register SSIF (CPG_RST_SSIF).....	268
7.2.4.89	Reset Control Register USB (CPG_RST_USB).....	269
7.2.4.90	Reset Control Register ETH (CPG_RST_ETH)	270
7.2.4.91	Reset Control Register I2C (CPG_RST_I2C)	271
7.2.4.92	Reset Control Register SCIF (CPG_RST_SCIF)	272
7.2.4.93	Reset Control Register SCI (CPG_RST_SCI).....	274
7.2.4.94	Reset Control Register IRDA (CPG_RST_IRDA)	275
7.2.4.95	Reset Control Register RSPI (CPG_RST_RSPI).....	276
7.2.4.96	Reset Control Register CANFD (CPG_RST_CANFD).....	277
7.2.4.97	Reset Control Register GPIO (CPG_RST_GPIO).....	278
7.2.4.98	Reset Control Register ADC (CPG_RST_ADC)	279
7.2.4.99	Reset Control Register TSU (CPG_RST_TSU)	280
7.2.4.100	Reset Control Register AXI_TZCDDR (CPG_RST_AXI_TZCDDR)	281
7.2.4.101	Reset Control Register AX45MP (CPG_RST_AX45MP).....	282
7.2.4.102	Reset Control Register NCEPLDM (CPG_RST_NCEPLDM)	283
7.2.4.103	Reset Control Register NCEPLMT (CPG_RST_NCEPLMT).....	284
7.2.4.104	Reset Control Register NCEPLIC (CPG_RST_NCEPLIC)	285
7.2.4.105	Reset Monitor Register SRAM_ACPU (CPG_RSTMON_SRAM_ACPU).....	286
7.2.4.106	Reset Monitor Register SRAM_MCPU (CPG_RSTMON_SRAM_MCPU).....	287
7.2.4.107	Reset Monitor Register IAX45 (CPG_RSTMON_IAX45).....	288
7.2.4.108	Reset Monitor Register SYC (CPG_RSTMON_SYC).....	289
7.2.4.109	Reset Monitor Register DMAC (CPG_RSTMON_DMAC)	290
7.2.4.110	Reset Monitor Register GTM (CPG_RSTMON_GTM).....	291
7.2.4.111	Reset Monitor Register MTU (CPG_RSTMON_MTU).....	292
7.2.4.112	Reset Monitor Register POE3 (CPG_RSTMON_POE3).....	293
7.2.4.113	Reset Monitor Register WDT (CPG_RSTMON_WDT)	294
7.2.4.114	Reset Monitor Register DDR (CPG_RSTMON_DDR).....	295
7.2.4.115	Reset Monitor Register SPI (CPG_RSTMON_SPI)	296
7.2.4.116	Reset Monitor Register SDHI (CPG_RSTMON_SDHI).....	297
7.2.4.117	Reset Monitor Register SSIF (CPG_RSTMON_SSIF).....	298
7.2.4.118	Reset Monitor Register USB (CPG_RSTMON_USB).....	299
7.2.4.119	Reset Monitor Register ETH (CPG_RSTMON_ETH)	300
7.2.4.120	Reset Monitor Register I2C (CPG_RSTMON_I2C).....	301
7.2.4.121	Reset Monitor Register SCIF (CPG_RSTMON_SCIF)	302
7.2.4.122	Reset Monitor Register SCI (CPG_RSTMON_SCI).....	303
7.2.4.123	Reset Monitor Register IRDA (CPG_RSTMON_IRDA).....	304
7.2.4.124	Reset Monitor Register RSPI (CPG_RSTMON_RSPI).....	305
7.2.4.125	Reset Monitor Register CANFD (CPG_RSTMON_CANFD).....	306
7.2.4.126	Reset Monitor Register GPIO (CPG_RSTMON_GPIO).....	307
7.2.4.127	Reset Monitor Register ADC (CPG_RSTMON_ADC).....	308
7.2.4.128	Reset Monitor Register TSU (CPG_RSTMON_TSU)	309

7.2.4.129	Reset Monitor Register AXI_TZCDDR (CPG_RSTMON_AXI_TZCDDR)	310
7.2.4.130	Reset Monitor Register AX45MP (CPG_RSTMON_AX45MP)	311
7.2.4.131	Reset Monitor Register NCEPLDM (CPG_RSTMON_NCEPLDM)	312
7.2.4.132	Reset Monitor Register NCEPLMT (CPG_RSTMON_NCEPLMT)	313
7.2.4.133	Reset Monitor Register NCEPLIC (CPG_RSTMON_NCEPLIC)	314
7.2.4.134	WDT Overflow System Reset Register (CPG_WDTOVF_RST)	315
7.2.4.135	WDT Reset Selector Register (CPG_WDTRST_SEL)	316
7.2.4.136	MSTOP Register ACPU (CPG_BUS_ACPU_MSTOP)	317
7.2.4.137	MSTOP Register MCPU1 (CPG_BUS_MCPU1_MSTOP)	318
7.2.4.138	MSTOP Register MCPU2 (CPG_BUS_MCPU2_MSTOP)	320
7.2.4.139	MSTOP Register PERI_COM (CPG_BUS_PERI_COM_MSTOP)	323
7.2.4.140	MSTOP Register PERI_CPU (CPG_BUS_PERI_CPU_MSTOP)	325
7.2.4.141	MSTOP Register PERI_DDR (CPG_BUS_PERI_DDR_MSTOP)	328
7.2.4.142	MSTOP Register REG0 (CPG_BUS_REG0_MSTOP)	329
7.2.4.143	MSTOP Register REG1 (CPG_BUS_REG1_MSTOP)	331
7.2.4.144	MSTOP Register TZCDDR (CPG_BUS_TZCDDR_MSTOP)	333
7.2.4.145	Other Function Register 2 (CPG_OTHERFUNC2_REG)	334
7.2.4.146	Clock Control Register MBUS (CPG_CLKON_MBUS)	335
7.2.4.147	Clock Monitor Register MBUS (CPG_CLKMON_MBUS)	336
7.3	Functions of the CPG	337
7.3.1	Clock Control	337
7.3.1.1	PLL Control, Setting, and Monitoring Functions	337
7.3.1.2	Clock Frequency Dividers and Selectors	339
7.3.1.3	Fixed Frequency Dividers	339
7.3.1.4	PLL Clock Monitoring	340
7.3.2	Clock Generation and Control Functions	341
7.3.2.1	Range of Reset Application	341
7.3.2.2	System Reset (External Pin)	342
7.3.2.3	WDT System Reset	342
7.3.2.4	Module Reset Application Control	346
7.4	Operating Procedures	347
7.4.1	Procedures for Supplying and Stopping Module Clocks	347
7.4.2	Procedures for Supplying and Stopping Reset Signals	348
7.4.3	Procedure for Activating Modules	349
7.4.4	Procedures for PLL Setup	349
7.4.4.1	Procedure for Setting PLL Normal Mode (Changing the Output Clock and SSCG Mode)	349
7.4.4.2	Procedure for Setting PLL Standby Mode	350
7.4.4.3	PLLs with Restrictions	350
7.4.5	Procedure for Switching the Division Ratio of the Dynamic Switching Frequency Dividers	351
7.4.6	Procedure for Switching Clocks by the Dynamic Switching Frequency Selectors	352
7.4.7	Procedure for Switching Clocks by the Static Switching Frequency Dividers and Selectors (Procedure for Switching Source Clocks)	353
7.4.8	Boot Sequence (Normal Operation)	353
7.4.9	Boot Sequence (Debug Mode)	353
7.4.10	General Operating Procedures	354
7.4.10.1	Procedure for Writing to Registers	354

8.	Interrupt Controller	355
8.1	Features	355
8.1.1	External Signal Pins	356
8.1.2	Block Diagram	357
8.2	Interrupt Mapping	358
8.3	PLIC Register Configuration	371
8.4	PLIC Register Descriptions	372
8.5	IAX45 Register Configuration.....	373
8.6	IAX45 Register Descriptions	374
8.6.1	NMI Status Control Register (NSCR).....	374
8.6.2	NMI Interrupt Type Selection Register (NITSR).....	375
8.6.3	IRQ Status Control Register (ISCR).....	376
8.6.4	IRQ Interrupt Type Selection Register (IITSR).....	377
8.6.5	TINT Status Control Register (TSCR).....	378
8.6.6	TINT Interrupt Type Selection Register0 (TITSR0).....	379
8.6.7	TINT Interrupt Type Selection Register1 (TITSR1).....	379
8.6.8	TINT Source Selection Register0 (TSSR0).....	380
8.6.9	TINT Source Selection Register1 (TSSR1).....	381
8.6.10	TINT Source Selection Register2 (TSSR2).....	382
8.6.11	TINT Source Selection Register3 (TSSR3).....	383
8.6.12	TINT Source Selection Register4 (TSSR4).....	384
8.6.13	TINT Source Selection Register5 (TSSR5).....	385
8.6.14	TINT Source Selection Register6 (TSSR6).....	386
8.6.15	TINT Source Selection Register7 (TSSR7).....	387
8.6.16	Bus Error Interrupt Status Control Register0 (BEISR0).....	388
8.6.17	Bus Error Interrupt Status Control Register1 (BEISR1).....	389
8.6.18	ECCRAM Error Interrupt Status Control Register0 (EREISR0).....	390
8.6.19	ECCRAM Error Interrupt Status Control Register1 (EREISR1).....	392
8.6.20	NMI Interrupt Mask Control Register (NMSK).....	394
8.6.21	IRQ Interrupt Mask Control Register (IMSK).....	395
8.6.22	TINT Interrupt Mask Control Register (TMSK).....	396
8.7	Operation.....	397
8.7.1	NMI Interrupt.....	397
8.7.2	IRQ Interrupt.....	398
8.7.3	GPIO Interrupt (TINT).....	399
8.7.4	Internal Interrupt	401
8.7.4.1	Bus Error Interrupt	401
8.7.4.2	ECCRAM Error Interrupt.....	403
8.8	Usage Note	405
8.8.1	Precaution when use the peripheral modules which can initiate DMA Controller.....	405
8.8.2	Clear Timing of Interrupt Cause	405

8.8.3	Precaution when Changing Interrupt Settings.....	405
8.8.4	Interrupt Flow.....	406
9.	DDR3L/DDR4 SDRAM Memory Controller (MEMC)	408
9.1	Features	408
9.2	Interface	410
9.2.1	Power, Ground	410
9.2.2	External Pins	410
9.3	Usage Note	411
9.3.1	Power On.....	411
10.	On-chip RAM.....	412
10.1	Features	412
11.	Error Correcting Code (ECC) for On-Chip RAM	413
11.1	Overview	413
11.1.1	Features	413
11.2	Register Configuration	414
11.3	Register Descriptions	417
11.3.1	ECC Control Registers_n (<REG_base>CTL_n) (n = 0 to 7)	417
11.3.2	ECC Error Address Registers m_n (<REG_base>EADm_n) (m = 0 to 7) (n = 0 to 7)	420
11.4	Initializing the ECC Function	421
11.5	Initializing the Detection-Usage Areas of the On-Chip RAM	421
11.6	Usage Notes.....	422
11.6.1	Notes on Setting the Registers of This Module.....	422
11.6.2	8- or 16-Bit Access	422
11.6.3	Numbers of Cycles for Reading from or Writing to a RAM Area with the ECC Function Enabled	422
11.6.4	ECC Error Address Register Overwrite Conditions.....	423
13.	Address Space Controller (TZC)	424
13.1	Overview	424
13.1.1	Features	424
13.1.2	Block Diagram	425
13.1.3	External Pins	426
13.2	Register Configuration	427
13.3	Register Descriptions	428
13.4	Operation.....	428
13.5	Usage Note	428
14.	Direct Memory Access Controller	429
14.1	Features	429
14.2	Input/Output Pins	429
14.3	Register Configuration	430

14.4	Register Descriptions	432
14.4.1	Next Source Address Register n/nS (N0SA_n/nS, N1SA_n/nS)	444
14.4.2	Next Destination Address Register n/nS (N0DA_n/nS, N1DA_n/nS)	444
14.4.3	Next Transaction Byte Register n/nS (N0TB_n/nS, N1TB_n/nS)	445
14.4.4	Current Source Address Register n/nS (CRSA_n/nS)	446
14.4.5	Current Destination Address Register n/nS (CRDA_n/nS)	447
14.4.6	Current Transaction Byte Register n/nS (CRTB_n/nS)	448
14.4.7	Channel Status Register n/nS (CHSTAT_n/nS)	449
14.4.8	Channel Control Register n/nS (CHCTRL_n/nS)	453
14.4.9	Channel Configuration Register n/nS (CHCFG_n/nS)	455
14.4.10	Channel Interval Register n/nS (CHITVL_n/nS)	458
14.4.11	Channel Extension Register n/nS (CHEXT_n/nS)	459
14.4.12	Next Link Address Register n/nS (NXLA_n/nS)	460
14.4.13	Current Link Address Register n/nS (CRLA_n/nS)	460
14.4.14	DMA Control Register (DCTRL_0_7/0_7S, DCTRL_8_15/8_15S)	461
14.4.15	DMA Status EN Register (DSTAT_EN_0_7/0_7S)	462
14.4.16	DMA Status EN Register (DSTAT_EN_8_15/8_15S)	463
14.4.17	DMA Status ER Register (DSTAT_ER_0_7/0_7S)	464
14.4.18	DMA Status ER Register (DSTAT_ER_8_15/8_15S)	465
14.4.19	DMA Status END Register (DSTAT_END_0_7/0_7S)	466
14.4.20	DMA Status END Register (DSTAT_END_8_15/8_15S)	467
14.4.21	DMA Status TC Register (DSTAT_TC_0_7/0_7S)	468
14.4.22	DMA Status TC Register (DSTAT_TC_8_15/8_15S)	469
14.4.23	DMA Status SUS Register (DSTAT_SUS_0_7/0_7S)	470
14.4.24	DMA Status SUS Register (DSTAT_SUS_8_15/8_15S)	471
14.4.25	DMA Extension Resource Selectors 0/0S to 7/7S (DMARS0/0S to DMARS7/7S)	472
14.5	Operation	475
14.5.1	Transfer Flow	475
14.5.2	DMA Transfer Requests	476
14.6	DMA Mode	482
14.6.1	Mode Setting	482
14.6.2	Register Mode	483
14.6.3	Link Mode	489
14.7	DMA Transfer	498
14.7.1	Transfer Mode	498
14.7.2	Priority Control for DMA Channels	499
14.7.3	DMA Transfer Request	502
14.7.4	DMA Transfer End Interrupt	502
14.7.5	DMA Error Interrupt	503
14.7.6	Interval Count Function	503
14.7.7	Difference in Operation Due to the Transfer Size	504

14.7.8	Transfer Status	506
14.8	DMA Setting Examples	510
14.8.1	Setting Example 1 (Register Mode/Hardware Request)	510
14.8.2	Setting Example 2 (Register Mode/Software Request).....	512
14.8.3	Setting Example 3 (Register Mode/Continuous Execution)	514
14.8.4	Setting Example 4 (Link Mode)	516
14.8.5	Next Register Set Continuous Execution Setting.....	519
14.9	Points for Caution.....	522
14.9.1	Problem of the Interrupt Signal Overtaking DMA Transfer	522
14.9.1.1	Overview.....	522
14.9.1.2	Workaround	522
15.	Machine Timer.....	523
15.1	Features	523
15.2	Register Configuration	524
15.3	Register Descriptions	524
16.	Multi-Function Timer Pulse Unit 3 (MTU3a)	525
16.1	Overview	525
16.2	Register Descriptions	531
16.2.1	Timer Control Register (TCR)	536
16.2.2	Timer Control Register 2 (TCR2)	538
16.2.3	Timer Mode Register 1 (TMDR1).....	543
16.2.4	Timer Mode Registers 2 (TMDR2A and TMDR2B).....	546
16.2.5	Timer Mode Register 3 (TMDR3).....	547
16.2.6	Timer I/O Control Register (TIOR)	549
16.2.7	Timer Compare Match Clear Register (TCNTCMPCLR)	568
16.2.8	Timer Interrupt Enable Register (TIER)	569
16.2.9	Timer Status Register (TSR).....	573
16.2.10	Timer Buffer Operation Transfer Mode Register (TBTM).....	574
16.2.11	Timer Input Capture Control Register (TICCR).....	576
16.2.12	Timer Synchronous Clear Register (TSYCR)	577
16.2.13	Timer Counter (TCNT)	578
16.2.14	Timer Longword Counter (TCNTLW).....	579
16.2.15	Timer General Register (TGR).....	580
16.2.16	Timer Longword General Registers (TGRALW and TGRBLW).....	582
16.2.17	Timer Start Registers (TSTRA, TSTRB, and TSTR).....	583
16.2.18	Timer Synchronous Registers (TSYRA and TSYRB)	586
16.2.19	Timer Counter Synchronous Start Register (TCSYSTR).....	588
16.2.20	Timer Read/Write Enable Registers (TRWERA and TRWERB).....	590
16.2.21	Timer Output Master Enable Registers (TOERA and TOERB)	591
16.2.22	Timer Output Control Registers 1 (TOCR1A and TOCR1B).....	593
16.2.23	Timer Output Control Registers 2 (TOCR2A and TOCR2B).....	595

16.2.24	Timer Output Level Buffer Registers (TOLBRA and TOLBRB)	598
16.2.25	Timer Gate Control Register A (TGCRA).....	599
16.2.26	Timer Subcounters (TCNTSA and TCNTSB).....	601
16.2.27	Timer Cycle Data Registers (TCDRA and TCDRB).....	601
16.2.28	Timer Cycle Buffer Registers (TCBRA and TCBRB)	602
16.2.29	Timer Dead Time Data Registers (TDDRA and TDDRBR)	602
16.2.30	Timer Dead Time Enable Registers (TDERA and TDERB).....	603
16.2.31	Timer Buffer Transfer Set Registers (TBTERA and TBTERB)	604
16.2.32	Timer Waveform Control Registers (TWCRA and TWCRB).....	605
16.2.33	Noise Filter Control Register n (NFCRn) (n = 0 to 4, 6, 7, 8, C)	607
16.2.34	Noise Filter Control Register 5 (NFCR5).....	611
16.2.35	Timer A/D Converter Start Request Control Register (TADCR)	612
16.2.36	Timer A/D Converter Start Request Cycle Set Registers (TADCORA and TADCORB)....	616
16.2.37	Timer A/D Converter Start Request Cycle Set Buffer Registers (TADCOBRA and TADCOBRB)	617
16.2.38	Timer Interrupt Skipping Mode Registers (TITMRA and TITMRB)	617
16.2.39	Timer Interrupt Skipping Set Registers 1 (TITCR1A and TITCR1B).....	618
16.2.40	Timer Interrupt Skipping Counters 1 (TITCNT1A and TITCNT1B)	621
16.2.41	Timer Interrupt Skipping Set Registers 2 (TITCR2A and TITCR2B).....	623
16.2.42	Timer Interrupt Skipping Counters 2 (TITCNT2A and TITCNT2B)	625
16.2.43	Bus Master Interface	627
16.3	Operation.....	628
16.3.1	Basic Functions	628
16.3.2	Synchronous Operation.....	634
16.3.3	Buffer Operation	636
16.3.4	Cascaded Operation	641
16.3.5	PWM Modes	646
16.3.6	Phase Counting Mode.....	651
16.3.6.1	16-Bit Phase Counting Mode.....	652
16.3.6.2	Cascade Connection 32-Bit Phase Counting Mode	663
16.3.7	Reset-Synchronized PWM Mode	666
16.3.8	Complementary PWM Mode	669
16.3.9	A/D Converter Start Request Delaying Function.....	717
16.3.10	Synchronous Operation of MTU0 to MTU4, MTU6, and MTU7	725
16.3.11	External Pulse Width Measurement.....	729
16.3.12	Dead Time Compensation.....	730
16.3.13	TCNTU, TCNTV, and TCNTW Capture at Crest and/or Trough in Complementary PWM Mode.....	732
16.3.14	Noise Filter Function	733
16.4	Interrupt Sources.....	734
16.4.1	Interrupt Sources and Priorities.....	734
16.4.2	DMAC Activation	735

16.4.3	A/D Converter Activation	736
16.5	Operation Timing	738
16.5.1	Input/Output Timing	738
16.5.2	Interrupt Signal Timing	744
16.6	Usage Note	747
16.6.1	Count Clock Restrictions	747
16.6.2	Note on Cycle Setting	747
16.6.3	Contention between TCNT Write and Clear Operations	748
16.6.4	Contention between TCNT Write and Increment Operations	748
16.6.5	Contention between TGR Write Operation and Compare Match	749
16.6.6	Contention between Buffer Register Write Operation and Compare Match	749
16.6.7	Contention between Buffer Register Write and TCNT Clear Operations	750
16.6.8	Contention between TGR Read Operation and Input Capture	750
16.6.9	Contention between TGR Write Operation and Input Capture	751
16.6.10	Contention between Buffer Register Write Operation and Input Capture	752
16.6.11	Contention between MTU2.TCNT Write Operation and Overflow/Underflow in Cascaded Operation	753
16.6.12	Counter Value When Count Operation is Stopped in Complementary PWM Mode	754
16.6.13	Buffer Operation Setting in Complementary PWM Mode	754
16.6.14	Buffer Operation and Compare Match in Reset-Synchronized PWM Mode	755
16.6.15	Overflow in Reset-Synchronized PWM Mode	756
16.6.16	Contention between Overflow/Underflow and Counter Clearing	757
16.6.17	Contention between TCNT Write Operation and Overflow/Underflow	758
16.6.18	Note on Transition from Normal Mode or PWM Mode 1 to Reset-Synchronized PWM Mode	758
16.6.19	Output Level in Complementary PWM Mode and Reset-Synchronized PWM Mode	758
16.6.20	Simultaneous Input Capture in MTU1.TCNT and MTU2.TCNT in Cascade Connection ..	759
16.6.21	Interrupt-Skipping Function 2	759
16.6.22	Notes When Complementary PWM Mode Output Protection Function is Not Used	759
16.6.23	Notes Regarding Timer Counter (MTU5.TCNT) and Timer General Register (MTU5.TGR)	760
16.6.24	Notes to Prevent Malfunctions in Synchronous Clearing for Complementary PWM Mode	761
16.6.25	Continuous Output of Interrupt Signal in Response to a Compare Match	763
16.6.26	Notes on A/D Converter Start Request Delaying Function in Complementary PWM Mode	764
16.7	MTU Output Pin Initialization	766
16.7.1	Operating Modes	766
16.7.2	Operation in Case of Re-Setting Due to Error during Operation	766
16.7.3	Overview of Initialization Procedures and Mode Transitions in Case of Error during Operation	767

17.	Port Output Enable 3 (POE3)	797
17.1	Overview	797
17.2	Register Descriptions	800
17.2.1	Input Level Control/Status Register 1 (ICSR1)	801
17.2.2	Input Level Control/Status Register 2 (ICSR2)	802
17.2.3	Input Level Control/Status Register 3 (ICSR3)	803
17.2.4	Input Level Control/Status Register 4 (ICSR4)	805
17.2.5	Output Level Control/Status Register 1 (OCSR1)	807
17.2.6	Output Level Control/Status Register 2 (OCSR2)	808
17.2.7	Software Port Output Enable Register (SPOER)	809
17.2.8	Port Output Enable Control Register 1 (POECR1)	811
17.2.9	Port Output Enable Control Register 2 (POECR2)	812
17.2.10	Port Output Enable Control Register 4 (POECR4)	814
17.2.11	Port Output Enable Control Register 5 (POECR5)	816
17.3	Operation	817
17.3.1	MTU Pin Selection	820
17.3.2	Input Level Detection Operation	823
17.3.3	Output Level Compare Operation	825
17.3.4	High-Impedance Control Using Registers	825
17.3.5	Additional Functions for Controlling High-Impedance States	825
17.3.6	Release from High-Impedance State	826
17.4	POE3 Setting Procedure	827
17.5	Interrupts	828
17.6	Usage Notes	829
17.6.1	High-Impedance Control when MTU6 and MTU7 are not Used	829
20.	General Timer (GTM)	830
20.1	Functional Overview	830
20.1.1	Features of GTM	830
20.2	Registers	832
20.2.1	Registers Overview	832
20.2.2	Details of OSTM Registers	833
20.2.2.1	OSTMnCMP — OSTM Compare Register	833
20.2.2.2	OSTMnCNT — OSTM Counter Register	834
20.2.2.3	OSTMnTE — OSTM Count Enable Status Register	835
20.2.2.4	OSTMnTS — OSTM Count Start Trigger Register	836
20.2.2.5	OSTMnTT — OSTM Count Stop Trigger Register	836
20.2.2.6	OSTMnCTL — OSTM Control Register	837
20.3	Functional Description	838
20.3.1	Block Diagram	838
20.3.2	Count Clock	839
20.3.3	Generation of Interrupt Request	839
20.3.4	Starting and Stopping the Timer	840

20.3.5	Interval Timer Mode	841
20.3.5.1	Basic Operation in Interval Timer Mode	841
20.3.5.2	Operation when OSTMnCMP = H'0000 0000	843
20.3.6	Free-Running Comparison Mode	844
20.3.6.1	Basic Operation in Free-Running Comparison Mode	844
20.3.6.2	Operation when OSTMnCMP = H'0000 0000	846
21.	Watchdog Timer (WDT)	847
21.1	Features	848
21.1.1	Normal Watchdog Timer Function.....	848
21.1.2	Reset Request Function due to CPU Parity Error.....	848
21.1.3	Internal Block Diagram	849
21.1.4	Input/Output Pin.....	850
21.2	Register Configuration	851
21.3	Register Descriptions	852
21.3.1	WDT Control Register_n (WDTCNT_n) (n = 0).....	852
21.3.2	WDT Period Setting Register_n (WDTSET_n) (n = 0).....	853
21.3.3	WDT Elapsed Time Register_n (WDTTIM_n (n = 0))	854
21.3.4	WDT Interrupt Control Register_n (WDTINT_n (n = 0)).....	855
21.3.5	Parity Error Control Register_n (PECR_n (n = 0))	856
21.3.6	Parity Error Forced Enable Register_n (PEEN_n (n = 0))	857
21.3.7	Parity Error Status Register_n (PESR_n (n = 0)).....	858
21.3.8	Parity Error Enable Register_n (PEER_n (n = 0)).....	859
21.3.9	Parity Error Polarity Setting Register_n (PEPO_n (n = 0))	860
21.3.10	Register Setting Order for Each WDT Channel	861
21.4	Operation.....	862
21.4.1	WDT_CORE Operaton Timing	862
21.4.2	WDT Interrupt Control Register (WDTINT) Specification for Write Access Interval	863
21.4.3	Watchdog Timer Operation Reflection Timing of Register Setting Value	864
21.4.4	Timing of Reflecting WDT Counter Value to WDTTIM Register	866
21.4.5	Conditions Under which WDTRSTB and PERROUT Operate.....	867
21.5	Reset Control	871
21.5.1	WDTRST Control of Each WDT Channels.....	871
21.6	Usage Note	872
22.	Serial Communications Interface with FIFO (SCIFA)	873
22.1	Overview	873
22.2	Register Descriptions	875
22.2.1	Receive Shift Register (RSR).....	876
22.2.2	Receive FIFO Data Register (FRDR).....	876
22.2.3	Transmit Shift Register (TSR)	876
22.2.4	Transmit FIFO Data Register (FTDR)	877
22.2.5	Serial Mode Register (SMR)	878

22.2.6	Serial Control Register (SCR)	880
22.2.7	Serial Status Register (FSR)	882
22.2.8	Bit Rate Register (BRR)	886
22.2.9	Modulation Duty Register (MDDR)	891
22.2.10	FIFO Control Register (FCR)	894
22.2.11	FIFO Data Count Register (FDR)	896
22.2.12	Serial Port Register (SPTR)	897
22.2.13	Line Status Register (LSR)	900
22.2.14	Serial Extended Mode Register (SEMR)	901
22.2.15	FIFO Trigger Control Register (FTCR)	903
22.3	Operation	904
22.3.1	Overview	904
22.3.2	Operation in Asynchronous Mode	906
22.3.3	Operation in Clock Synchronous Mode	917
22.4	Bit Rate Modulation	926
22.5	Interrupt Sources	927
22.6	Serial Port Register (SPTR) and SCIFA-Related Pins	928
22.7	Noise Cancellation	930
22.8	Usage Notes	931
22.8.1	FTDR Register Writing and TDFE Flag	931
22.8.2	FRDR Register Reading and RDF Flag	931
22.8.3	Break Detection and Processing	931
22.8.4	Writing to the SPTR Register	931
22.8.5	Break Signal Transmission	932
22.8.6	Receive Data Sampling Timing and Receive Margin in Asynchronous Mode	933
22.8.7	Note on FER Flag and PER Flag in Serial Status Register (FSR)	934
22.8.8	Notes on External Clock Input in Clock Synchronous Mode	934
22.8.9	Module Standby Mode Setting	934
22.8.10	Notes on Operation for Reception when an Internal Clock is Selected in Clock Synchronous Mode	934
23.	Serial Communications Interface (SClg)	935
23.1	Overview	935
23.2	Register Descriptions	938
23.2.1	Receive Shift Register (RSR)	939
23.2.2	Receive Data Register (RDR)	939
23.2.3	Receive Data Register H, L, HL (RDRH, RDRL, RDRHL)	940
23.2.4	Transmit Data Register (TDR)	941
23.2.5	Transmit Data Register H, L, HL (TDRH, TDRL, TDRHL)	942
23.2.6	Transmit Shift Register (TSR)	942
23.2.7	Serial Mode Register (SMR)	943
23.2.8	Serial Control Register (SCR)	947

23.2.9	Serial Status Register (SSR).....	952
23.2.10	Smart Card Mode Register (SCMR).....	958
23.2.11	Bit Rate Register (BRR)	960
23.2.12	Modulation Duty Register (MDDR).....	964
23.2.13	Serial Extended Mode Register (SEMR).....	965
23.2.14	Noise Filter Setting Register (SNFR)	967
23.2.15	Extended function control register (SECR)	968
23.3	Operation in Asynchronous Mode.....	969
23.3.1	Serial Data Transfer Format.....	970
23.3.2	Receive Data Sampling Timing and Reception Margin in Asynchronous Mode.....	971
23.3.3	Clock.....	972
23.3.4	Double-Speed Mode	972
23.3.5	CTS and RTS Functions	973
23.3.6	SCI Initialization (Asynchronous Mode)	974
23.3.7	Serial Data Transmission (Asynchronous Mode).....	975
23.3.8	Serial Data Reception (Asynchronous Mode).....	979
23.4	Multi-Processor Communications Function	983
23.4.1	Multi-Processor Serial Data Transmission	984
23.4.2	Multi-Processor Serial Data Reception	985
23.5	Operation in Clock Synchronous Mode	988
23.5.1	Clock.....	989
23.5.2	CTS and RTS Functions	989
23.5.3	SCI Initialization (Clock Synchronous Mode).....	990
23.5.4	Serial Data Transmission (Clock Synchronous Mode).....	991
23.5.5	Serial Data Reception (Clock Synchronous Mode).....	996
23.5.6	Simultaneous Serial Data Transmission and Reception (Clock Synchronous Mode)	999
23.6	Operation in Smart Card Interface Mode	1001
23.6.1	Sample Connection	1001
23.6.2	Data Format (Except in Block Transfer Mode).....	1002
23.6.3	Block Transfer Mode	1004
23.6.4	Receive Data Sampling Timing and Reception Margin.....	1005
23.6.5	SCI Initialization (Smart Card Interface Mode).....	1006
23.6.6	Serial Data Transmission (Except in Block Transfer Mode)	1007
23.6.7	Serial Data Reception (Except in Block Transfer Mode).....	1010
23.6.8	Clock Output Control	1012
23.7	Noise Cancellation Function	1013
23.8	Interrupt Sources.....	1014
23.8.1	Buffer Operations for TXI and RXI Interrupts	1014
23.8.2	Interrupts in Asynchronous Mode and Clock Synchronous Mode	1014
23.8.3	Interrupts in Smart Card Interface Mode.....	1015

23.9	Usage Notes.....	1016
23.9.1	Break Detection and Processing.....	1016
23.9.2	Mark State and Production of Breaks	1016
23.9.3	Receive Error Flags and Transmit Operations (Clock Synchronous Mode)	1016
23.9.4	Writing Data to TDR	1016
23.9.5	Restrictions on Clock Synchronous Transmission (Clock Synchronous Mode)	1017
23.9.6	Restrictions on Using DMAC.....	1019
23.9.7	Notes on Starting Transfer	1019
23.9.8	External Clock Input in Clock Synchronous Mode	1019
23.9.9	Note on Transmit Enable Bit (TE bit).....	1019
23.10	IrDA Communications	1020
23.11	Description of the IrDA Register.....	1021
23.11.1	IrDA Control Register (IRCR).....	1022
23.12	IrDA Operation	1023
23.12.1	Flow of Settings for IrDA Operation.....	1023
23.12.2	Transmission	1023
23.12.3	Reception	1024
23.12.4	Relationship between Bit Rate and High-Level Pulse Width	1024
23.13	Note on IrDA Usage	1025
23.13.1	Minimum Pulse Width in Reception.....	1025
23.13.2	Base Clock in Asynchronous Mode for the Serial Communications Interface	1025
24.	Renesas Serial Peripheral Interface.....	1026
24.1.1	Features	1026
24.2	Input/Output Pins	1029
24.3	Register Descriptions	1030
24.3.1	Control Register (SPCR).....	1032
24.3.2	Slave Select Polarity Register (SSLP)	1033
24.3.3	Pin Control Register (SPPCR)	1034
24.3.4	Status Register (SPSR).....	1035
24.3.5	Data Register (SPDR)	1037
24.3.6	Sequence Control Register (SPSCR)	1038
24.3.7	Sequence Status Register (SPSSR).....	1039
24.3.8	Bit Rate Register (SPBR).....	1040
24.3.9	Data Control Register (SPDCR).....	1041
24.3.10	Clock Delay Register (SPCKD).....	1042
24.3.11	Slave Select Negation Delay Register (SSLND).....	1043
24.3.12	Next-Access Delay Register (SPND).....	1044
24.3.13	Command Register (SPCMD).....	1045
24.3.14	Buffer Control Register (SPBFCR).....	1047
24.3.15	Buffer Data Count Setting Register (SPBFDR).....	1049

24.4	Operation.....	1050
24.4.1	Overview of Operations.....	1050
24.4.2	Pin Control.....	1051
24.4.3	System Configuration Example.....	1052
24.4.4	Transfer Format.....	1054
24.4.5	Data Format.....	1056
24.4.6	Error Detection.....	1062
24.4.7	Initialization.....	1065
24.4.8	SPI Operation.....	1066
24.4.9	Error Handling.....	1076
24.4.10	Loopback Mode.....	1077
24.4.11	Interrupt Sources.....	1077
25.	SPI Multi I/O Bus Controller.....	1078
25.1	Features.....	1078
25.1.1	Serial Flash Memory Interface.....	1078
25.1.2	External Address Space Read Mode.....	1078
25.1.3	Manual Mode.....	1078
25.2	Block Diagram.....	1079
25.3	Input/Output Pins.....	1080
25.4	Register Descriptions.....	1081
25.4.1	Common Control Register (CMNCR).....	1082
25.4.2	SSL Delay Register (SSLDR).....	1084
25.4.3	Data Read Control Register (DRCR).....	1086
25.4.4	Data Read Command Setting Register (DRCMR).....	1088
25.4.5	Data Read Extended Address Setting Register (DREAR).....	1089
25.4.6	Data Read Option Setting Register (DROPR).....	1090
25.4.7	Data Read Enable Setting Register (DRENDR).....	1091
25.4.8	Manual Mode Control Register (SMCR).....	1093
25.4.9	Manual Mode Command Setting Register (SMCMR).....	1094
25.4.10	Manual Mode Address Setting Register (SMADR).....	1095
25.4.11	Manual Mode Option Setting Register (SMOPR).....	1096
25.4.12	Manual Mode Enable Setting Register (SMENR).....	1097
25.4.13	Manual Mode Read Data Register 0 (SMRDR0).....	1099
25.4.14	Manual Mode Write Data Register 0 (SMWDR0).....	1100
25.4.15	Common Status Register (CMNSR).....	1101
25.4.16	Data Read Dummy Cycle Setting Register (DRDMCR).....	1102
25.4.17	Data Read DDR Enable Register (DRDRENDR).....	1103
25.4.18	Manual Mode Dummy Cycle Setting Register (SMDMCR).....	1104
25.4.19	Manual Mode DDR Enable Register (SMDRENDR).....	1105
25.4.20	PHY Control Register (PHYCNT).....	1106
25.4.21	PHY Offset Register 1 (PHYOFFSET1).....	1108

25.4.22	PHY Offset Register 2 (PHYOFFSET2)	1110
25.4.23	PHY Interrupt Register (PHYINT)	1111
25.4.24	PHY Adjustment Register 1 (PHYADJ1)	1112
25.4.25	PHY Adjustment Register 2 (PHYADJ2)	1113
25.5	Operation	1114
25.5.1	System Configuration	1114
25.5.2	Address Map	1115
25.5.3	32-bit Serial Flash Addresses	1116
25.5.4	Operating Modes	1117
25.5.5	External Address Space Read Mode	1117
25.5.6	Read Cache	1122
25.5.7	Manual mode	1123
25.5.8	Command Sequence	1127
25.5.9	Data Pin Control	1131
25.5.10	QSPIn_SSL Pin Control	1132
25.5.11	Flags	1133
25.5.12	Write Buffer Operation	1134
25.5.13	Supported Protocol for Serial Flash Memory	1136
25.5.14	Timing Adjustment	1137
25.5.15	Data Alignment	1140
25.6	Usage Notes	1141
25.6.1	Transfer to read data while the signal on the QSPIn_SSL pin is de-asserted	1141
25.6.2	Transfer to read data while the signal on the QSPIn_SSL pin is asserted	1141
25.6.3	Notes on Starting Transfer from the QSPIn_SSL Retained State in Manual Mode	1141
25.6.4	Handling of QSPI_RESET#	1141
25.6.5	Software Reset after Release from the Module Stop State	1141
26.	I ² C Bus Interface	1142
26.1	Features	1142
26.1.1	Channels	1142
26.1.2	Register Base Addresses	1142
26.1.3	External I/O Signals	1143
26.2	Overview	1144
26.2.1	Functional Overview	1144
26.2.2	Block Diagram	1146
26.3	Registers	1148
26.3.1	RIICnCR1 — I ² C Bus Control Register 1	1149
26.3.2	RIICnCR2 — I ² C Bus Control Register 2	1152
26.3.3	RIICnMR1 — I ² C Bus Mode Register 1	1156
26.3.4	RIICnMR2 — I ² C Bus Mode Register 2	1158
26.3.5	RIICnMR3 — I ² C Bus Mode Register 3	1160
26.3.6	RIICnFER — I ² C Bus Function Enable Register	1163

26.3.7	RIICnSER — I ² C Bus Status Enable Register	1166
26.3.8	RIICnIER — I ² C Bus Interrupt Enable Register	1168
26.3.9	RIICnSR1 — I ² C Bus Status Register 1	1170
26.3.10	RIICnSR2 — I ² C Bus Status Register 2	1173
26.3.11	RIICnSARy — I ² C Slave Address Register y (y = 0 to 2).....	1178
26.3.12	RIICnBRL — I ² C Bus Bit Rate Low-Level Register	1180
26.3.13	RIICnBRH — I ² C Bus Bit Rate High-Level Register	1181
26.3.14	RIICnDRT — I ² C Bus Transmit Data Register	1184
26.3.15	RIICnDRR — I ² C Bus Receive Data Register.....	1185
26.3.16	RIICnDRS — I ² C Bus Shift Register	1186
26.4	Interrupt Sources.....	1187
26.5	Operation.....	1188
26.5.1	Communication Data Format	1188
26.5.2	Initial Settings	1190
26.5.3	Master Transmit Operation.....	1191
26.5.4	Master Receive Operation.....	1195
26.5.5	Slave Transmit Operation.....	1201
26.5.6	Slave Receive Operation.....	1204
26.6	SCL Synchronization Circuit	1207
26.7	Facility for Delaying SDA Output.....	1208
26.8	Digital Noise-Filter Circuits	1209
26.9	Address Match Detection	1210
26.9.1	Slave-Address Match Detection	1210
26.9.2	Detection of the General Call Address.....	1213
26.9.3	Device-ID Address Detection	1214
26.9.4	Host Address Detection.....	1216
26.10	Automatically Low-Hold Function for SCL	1217
26.10.1	Function to Prevent Wrong Transmission of Transmit Data	1217
26.10.2	NACK Reception Transfer Suspension Function	1218
26.10.3	Function to Prevent Failure to Receive Data	1219
26.11	Arbitration-Lost Detection Functions.....	1221
26.11.1	Master Arbitration-Lost Detection (MALE Bit)	1221
26.11.2	Function to Detect Loss of Arbitration during NACK Transmission (NALE Bit)	1224
26.11.3	Slave Arbitration-Lost Detection (SALE Bit).....	1225
26.12	Start Condition/Restart Condition/Stop Condition Issuing Function	1226
26.12.1	Issuing a Start Condition	1226
26.12.2	Issuing a Restart Condition	1227
26.12.3	Issuing a Stop Condition	1228
26.13	Bus Hanging.....	1229
26.13.1	Timeout Function.....	1229
26.13.2	Extra SCL Clock Cycle Output Function	1231

26.13.3	RIIC Reset and Internal Reset	1232
26.14	SMBus Operation	1233
26.14.1	SMBus Timeout Measurement.....	1233
26.14.2	SMBus Host Notification Protocol/Notify ARP Master.....	1234
26.15	Reset Function of RIIC.....	1235
27.	Serial Sound Interface (SSIF-2)	1237
27.1	Overview	1237
27.1.1	Features	1237
27.1.2	Block Diagram	1239
27.2	Input/Output Pins	1241
27.3	List of Registers	1242
27.4	Function Details	1244
27.4.1	Register Descriptions	1244
27.4.1.1	Control Register (SSICR)	1244
27.4.1.2	Status Register (SSISR).....	1257
27.4.1.3	FIFO Control Register (SSIFCR).....	1270
27.4.1.4	FIFO Status Register (SSIFSR)	1279
27.4.1.5	Transmit FIFO Data Register (SSIFTDR)	1283
27.4.1.6	Receive FIFO Data Register (SSIFRDR)	1286
27.4.1.7	Audio Format Register (SSIOFR).....	1288
27.4.1.8	Status Control Register (SSISCR).....	1292
27.4.2	Communication Formats	1293
27.4.2.1	I ² S Format.....	1294
27.4.2.2	Monaural Format	1295
27.4.2.3	TDM Format.....	1297
27.4.3	Communication Modes.....	1298
27.4.3.1	Slave-mode Communication	1299
27.4.3.2	Master-mode Communication	1299
27.4.3.3	Transmission	1299
27.4.3.4	Reception.....	1299
27.4.3.5	Transmission and Reception.....	1299
27.5	Operation.....	1300
27.5.1	Operational State.....	1300
27.5.1.1	Idle State.....	1300
27.5.1.2	Communication States	1303
27.5.2	Communication Operation.....	1307
27.5.2.1	Start Communication	1308
27.5.2.2	Transmission	1309
27.5.2.3	Reception.....	1311
27.5.2.4	Transmission and Reception	1312
27.5.2.5	Halt Communication	1313
27.5.2.6	Error Handling.....	1314
27.5.2.7	Resume Communication	1316
27.5.3	Interrupt Sources.....	1317
27.5.3.1	INT_ssif_int_req Interrupt.....	1317
27.5.3.2	INT_ssif_dma_tx Interrupt [full-duplex communication]	1319
27.5.3.3	INT_ssif_dma_rx Interrupt [full-duplex communication]	1319

27.5.3.4	INT_ssif_dma_rt Interrupt [half-duplex communication].....	1320
27.5.4	Software Resets	1321
27.5.4.1	Software Reset Procedure	1321
27.6	Notes	1323
27.6.1	Notes	1323
27.6.1.1	Attention by communication using DMA.....	1323
27.6.1.2	Notes for Slave-mode Communication.....	1323
27.6.1.3	Notes for Master-mode Communication.....	1324
27.6.1.4	Notes for Communication Flow	1324
27.6.1.5	Write Access Restriction.....	1326
28.	CANFD Interface (RS-CANFD)	1328
28.1	Features of RS-CANFD	1328
28.1.1	Number of Units and Channels	1328
28.1.2	Register Base Address.....	1330
28.1.3	Clock Supply.....	1330
28.1.4	Interrupt Request.....	1331
28.1.5	External Input/Output Signals.....	1331
28.2	Overview	1332
28.2.1	Functional Overview	1332
28.2.2	Interface Modes.....	1335
28.2.3	Block Diagram	1335
28.3	Registers (Classical CAN Mode).....	1336
28.3.1	List of Registers.....	1336
28.3.2	Details of Interface Mode-related Registers.....	1340
28.3.2.1	RSCANnGRMCFG — Global Interface Mode Select Register	1340
28.3.3	Details of Channel-related Registers.....	1341
28.3.3.1	RSCANnCmCFG — Channel Configuration Register (m = 0, 1).....	1341
28.3.3.2	RSCANnCmCTR — Channel Control Register (m = 0, 1).....	1343
28.3.3.3	RSCANnCmSTS — Channel Status Register (m = 0, 1).....	1348
28.3.3.4	RSCANnCmERFL — Channel Error Flag Register (m = 0, 1).....	1351
28.3.4	Details of Global-related Registers.....	1355
28.3.4.1	RSCANnGCFG — Global Configuration Register.....	1355
28.3.4.2	RSCANnGCTR — Global Control Register.....	1358
28.3.4.3	RSCANnGSTS — Global Status Register	1360
28.3.4.4	RSCANnGERFL — Global Error Flag Register	1362
28.3.4.5	RSCANnGTSC — Global Timestamp Counter Register.....	1364
28.3.4.6	RSCANnGTINTSTS0 — Global TX Interrupt Status Register 0	1365
28.3.4.7	RSCANnGFDCFG — Global FD configuration register	1367
28.3.5	Details of Receive Rule-related Registers	1368
28.3.5.1	RSCANnGAFLECTR — Receive Rule Entry Control Register.....	1368
28.3.5.2	RSCANnGAFLCFG0 — Receive Rule Configuration Register 0.....	1369
28.3.5.3	RSCANnGAFLIDj — Receive Rule ID Register (j = 0 to 15).....	1370
28.3.5.4	RSCANnGAFLMj — Receive Rule Mask Register (j = 0 to 15).....	1372
28.3.5.5	RSCANnGAFLP0_j — Receive Rule Pointer 0 Register (j = 0 to 15).....	1374
28.3.5.6	RSCANnGAFLP1_j — Receive Rule Pointer 0 Register (j = 0 to 15).....	1376
28.3.6	Details of Receive Buffer-related Registers	1377

28.3.6.1	RSCANnRMNB — Receive Buffer Number Register.....	1377
28.3.6.2	RSCANnRMNDy — Receive Buffer New Data Register (y = 0)	1378
28.3.6.3	RSCANnRMIDq — Receive Buffer ID Register (q = 0 to 31).....	1379
28.3.6.4	RSCANnRMPTRq — Receive Buffer Pointer Register (q = 0 to 31)	1380
28.3.6.5	RSCANnRMDF0_q — Receive Buffer Data Field 0 Register (q = 0 to 31).....	1382
28.3.6.6	RSCANnRMDF1_q — Receive Buffer Data Field 1 Register (q = 0 to 31).....	1383
28.3.7	Details of Receive FIFO Buffer-related Registers	1384
28.3.7.1	RSCANnRFCCx — Receive FIFO Buffer Configuration and Control Register (x = 0 to 7).....	1384
28.3.7.2	RSCANnRFSTsx — Receive FIFO Buffer Status Register (x = 0 to 7).....	1386
28.3.7.3	RSCANnRFPCTRx — Receive FIFO Buffer Pointer Control Register (x = 0 to 7)	1388
28.3.7.4	RSCANnRFIDx — Receive FIFO Buffer Access ID Register (x = 0 to 7)	1389
28.3.7.5	RSCANnRFPTRx — Receive FIFO Buffer Access Pointer Register (x = 0 to 7).....	1390
28.3.7.6	RSCANnRFDF0_x — Receive FIFO Buffer Access Data Field 0 Register (x = 0 to 7).....	1391
28.3.7.7	RSCANnRFDF1_x — Receive FIFO Buffer Access Data Field 1 Register (x = 0 to 7).....	1392
28.3.8	Details of Transmit/Receive FIFO Buffer-related Registers	1393
28.3.8.1	RSCANnCFCCk — Transmit/receive FIFO Buffer Configuration and Control Register k (k = 0 to 5)	1393
28.3.8.2	RSCANnCFSTSk — Transmit/receive FIFO Buffer Status Register (k = 0 to 5).....	1397
28.3.8.3	RSCANnCFPCTRk — Transmit/receive FIFO Buffer Pointer Control Register (k = 0 to 5).....	1400
28.3.8.4	RSCANnCFIDk — Transmit/receive FIFO Buffer Access ID Register (k = 0 to 5)	1402
28.3.8.5	RSCANnCFPTRk — Transmit/receive FIFO Buffer Access Pointer Register (k = 0 to 5).....	1404
28.3.8.6	RSCANnCFDF0_k — Transmit/receive FIFO Buffer Access Data Field 0 Register (k = 0 to 5)	1406
28.3.8.7	RSCANnCFDF1_k — Transmit/receive FIFO Buffer Access Data Field 1 Register (k = 0 to 5)	1407
28.3.9	Details of FIFO Status-related Registers	1408
28.3.9.1	RSCANnFESTS — FIFO Empty Status Register.....	1408
28.3.9.2	RSCANnFFSTS — FIFO Full Status Register	1410
28.3.9.3	RSCANnFMSTS — FIFO Message Lost Status Register.....	1412
28.3.9.4	RSCANnRFISTS — Receive FIFO Buffer Interrupt Flag Status Register	1414
28.3.9.5	RSCANnCFRISTS — Transmit/receive FIFO Buffer Receive Interrupt Flag Status Register	1415
28.3.9.6	RSCANnCFTISTS — Transmit/receive FIFO Buffer Transmit Interrupt Flag Status Register	1416
28.3.10	Details of Transmit Buffer-related Registers	1417
28.3.10.1	RSCANnTMCp — Transmit Buffer Control Register (p = 0 to 31)	1417
28.3.10.2	RSCANnTMSTSp — Transmit Buffer Status Register (p = 0 to 31)	1419
28.3.10.3	RSCANnTMIDp — Transmit Buffer ID Register (p = 0 to 31)	1421
28.3.10.4	RSCANnTMPTRp — Transmit Buffer Pointer Register (p = 0 to 31).....	1423
28.3.10.5	RSCANnTMDF0_p — Transmit Buffer Data Field 0 Register (p = 0 to 31)	1425
28.3.10.6	RSCANnTMDF1_p — Transmit Buffer Data Field 1 Register (p = 0 to 31)	1426
28.3.10.7	RSCANnTMIECy — Transmit Buffer Interrupt Enable Configuration Register (y = 0).....	1427
28.3.11	Details of Transmit Buffer Status-related Registers	1429

28.3.11.1	RSCANnTMTRSTSy — Transmit Buffer Transmit Request Status Register (y = 0).....	1429
28.3.11.2	RSCANnTMTARSTSy — Transmit Buffer Transmit Abort Request Status Register (y = 0).....	1431
28.3.11.3	RSCANnTMTCASTSy — Transmit Buffer Transmit Complete Status Register (y = 0).....	1433
28.3.11.4	RSCANnTMTASTSy — Transmit Buffer Transmit Abort Status Register (y = 0).....	1435
28.3.12	Details of Transmit Queue-related Registers	1437
28.3.12.1	RSCANnTXQCCm — Transmit Queue Configuration and Control Register (m = 0, 1).....	1437
28.3.12.2	RSCANnTXQSTSm — Transmit Queue Status Register (m = 0, 1).....	1439
28.3.12.3	RSCANnTXQPCTRM — Transmit Queue Pointer Control Register (m = 0, 1) ..	1441
28.3.13	Details of Transmit history-related Registers	1442
28.3.13.1	RSCANnTHLCCm — Transmit History Configuration and Control Register (m = 0, 1).....	1442
28.3.13.2	RSCANnTHLSTSm — Transmit History Status Register (m = 0, 1).....	1444
28.3.13.3	RSCANnTHLPCTRM — Transmit History Pointer Control Register (m = 0, 1) ..	1446
28.3.13.4	RSCANnTHLACCM — Transmit History Access Register (m = 0, 1).....	1447
28.3.14	Details of Test-related Registers	1449
28.3.14.1	RSCANnGTSTCFG — Global Test Configuration Register.....	1449
28.3.14.2	RSCANnGTSTCTR — Global Test Control Register.....	1451
28.3.14.3	RSCANnGLOCKK — Global Lock Key Register.....	1452
28.3.14.4	RSCANnRPGACCr — RAM Test Page Access Register (r = 0 to 63)	1453
28.4	Registers (CANFD Mode)	1454
28.4.1	List of Registers.....	1454
28.4.2	Details of Interface Mode-related Registers.....	1458
28.4.2.1	RSCFDnCFDGRMCFG — Global Interface Mode Select Register	1458
28.4.3	Details of Channel-related Registers.....	1459
28.4.3.1	RSCFDnCFDCmNCFG — Channel Nominal Bit Rate Configuration Register (m = 0, 1).....	1459
28.4.3.2	RSCFDnCFDCmCTR — Channel Control Register (m = 0, 1).....	1461
28.4.3.3	RSCFDnCFDCmSTS — Channel Status Register (m = 0, 1).....	1467
28.4.3.4	RSCFDnCFDCmERFL — Channel Error Flag Register (m = 0, 1).....	1470
28.4.3.5	RSCFDnCFDCmDCFG — Channel Data Bit Rate Configuration Register (m = 0, 1)	1474
28.4.3.6	RSCFDnCFDCmFDCFG — Channel CANFD Configuration Register (m = 0, 1)	1477
28.4.3.7	RSCFDnCFDCmFDCTR — Channel CANFD Control Register (m = 0, 1).....	1481
28.4.3.8	RSCFDnCFDCmFDSTS — Channel CANFD Status Register (m = 0, 1)	1482
28.4.3.9	RSCFDnCFDCmFDCRC — Channel CANFD CRC Register (m = 0, 1)	1484
28.4.4	Details of Global-related Registers.....	1486
28.4.4.1	SCFDnCFDGCFG — Global Configuration Register	1486
28.4.4.2	RSCFDnCFDGCTR — Global Control Register	1490
28.4.4.3	RSCFDnCFDGSTS — Global Status Register	1492
28.4.4.4	RSCFDnCFDGERFL — Global Error Flag Register	1494
28.4.4.5	RSCFDnCFDGTSC — Global Timestamp Counter Register	1496
28.4.4.6	RSCFDnCFDGTINTSTS0 — Global TX Interrupt Status Register 0	1497
28.4.4.7	RSCFDnCFDGFDCFG — Global FD Configuration Register.....	1499
28.4.5	Details of Receive Rule-related Registers	1500

28.4.5.1	RSCFDnCFDGAFLECTR — Receive Rule Entry Control Register	1500
28.4.5.2	RSCFDnCFDGAFLCFG0 — Receive Rule Configuration Register 0.....	1501
28.4.5.3	RSCFDnCFDGAFLIDj — Receive Rule ID Register (j = 0 to 15)	1502
28.4.5.4	RSCFDnCFDGAFLMj — Receive Rule Mask Register (j = 0 to 15).....	1504
28.4.5.5	RSCFDnCFDGAFLP0_j — Receive Rule Pointer 0 Register (j = 0 to 15).....	1506
28.4.5.6	RSCFDnCFDGAFLP1_j — Receive Rule Pointer 1 Register (j = 0 to 15).....	1508
28.4.6	Details of Receive Buffer-related Registers	1509
28.4.6.1	RSCFDnCFDRMNB — Receive Buffer Number Register	1509
28.4.6.2	RSCFDnCFDRMNDy — Receive Buffer New Data Register (y = 0)	1510
28.4.6.3	RSCFDnCFDRMIDq — Receive Buffer ID Register (q = 0 to 31)	1511
28.4.6.4	RSCFDnCFDRMPTRq — Receive Buffer Pointer Register (q = 0 to 31).....	1513
28.4.6.5	RSCFDnCFDRMFDSTsq — Receive Buffer CANFD Status Register (q = 0 to 31)	1515
28.4.6.6	RSCFDnCFDRMDFb_q — Receive Buffer Data Field b Register (b = 0 to 4, q = 0 to 31).....	1516
28.4.7	Details of Receive FIFO Buffer-related Registers	1517
28.4.7.1	RSCFDnCFDRFCCx — Receive FIFO Buffer Configuration and Control Register (x = 0 to 7)	1517
28.4.7.2	RSCFDnCFDRFSTSx — Receive FIFO Buffer Status Register (x = 0 to 7)	1520
28.4.7.3	RSCFDnCFDRFPCTRx — Receive FIFO Buffer Pointer Control Register (x = 0 to 7).....	1522
28.4.7.4	RSCFDnCFDRFIDx — Receive FIFO Buffer Access ID Register (x = 0 to 7)....	1523
28.4.7.5	RSCFDnCFDRFPTRx — Receive FIFO Buffer Access Pointer Register (x = 0 to 7)	1525
28.4.7.6	RSCFDnCFDRFFDSTSx — Receive FIFO CANFD Status Register (x = 0 to 7)	1527
28.4.7.7	RSCFDnCFDRFDFd_x — Receive FIFO Buffer Access Data Field d Register (d = 0 to 15, x = 0 to 7).....	1528
28.4.8	Transmit/Receive FIFO Buffer-related Registers	1529
28.4.8.1	RSCFDnCFDCFCCK — Transmit/receive FIFO Buffer Configuration and Control Register k (k = 0 to 5).....	1529
28.4.8.2	RSCFDnCFDCFSTSk — Transmit/receive FIFO Buffer Status Register (k = 0 to 5)	1533
28.4.8.3	RSCFDnCFDCFPCTRk — Transmit/receive FIFO Buffer Pointer Control Register (k = 0 to 5)	1536
28.4.8.4	RSCFDnCFDCFIDk — Transmit/receive FIFO Buffer Access ID Register (k = 0 to 5).....	1538
28.4.8.5	RSCFDnCFDCFPTRk — Transmit/receive FIFO Buffer Access Pointer Register (k = 0 to 5)	1540
28.4.8.6	RSCFDnCFDCFFDCSTSk — Transmit/Receive FIFO CANFD Configuration/ Status Register (k = 0 to 5).....	1542
28.4.8.7	RSCFDnCFDCFDf_k — Transmit/receive FIFO Buffer Access Data Field d Register (d = 0 to 15, k = 0 to 5).....	1544
28.4.9	Details of FIFO Status-related Registers	1545
28.4.9.1	RSCFDnCFDFESTS — FIFO Empty Status Register	1545
28.4.9.2	RSCFDnCFDFFSTS — FIFO Full Status Register	1547
28.4.9.3	RSCFDnCFDFMSTS — FIFO Message Lost Status Register	1549
28.4.9.4	RSCFDnCFDRFISTS — Receive FIFO Buffer Interrupt Flag Status Register ...	1551
28.4.9.5	RSCFDnCFDCFRISTS — Transmit/receive FIFO Buffer Receive Interrupt Flag Status Register	1552
28.4.9.6	RSCFDnCFDCFTISTS — Transmit/receive FIFO Buffer Transmit Interrupt Flag Status Register	1553

28.4.10	Details of FIFO DMA-related Registers.....	1554
28.4.10.1	RSCFDnCFDCDTCT — DMA Enable Register	1554
28.4.10.2	RSCFDnCFDCDTSTS — DMA Status Register	1556
28.4.11	Details of Transmit Buffer-related Registers	1558
28.4.11.1	RSCFDnCFDTMCp — Transmit Buffer Control Register (p = 0 to 31).....	1558
28.4.11.2	RSCFDnCFDTMSTSp — Transmit Buffer Status Register (p = 0 to 31).....	1560
28.4.11.3	RSCFDnCFDTMIDp — Transmit Buffer ID Register (p = 0 to 31).....	1562
28.4.11.4	RSCFDnCFDTMPTRp — Transmit Buffer Pointer Register (p = 0 to 31)	1564
28.4.11.5	RSCFDnCFDTMFDCTRp — Transmit Buffer CANFD Configuration Register (p = 0 to 31).....	1566
28.4.11.6	RSCFDnCFDTMDFb_p — Transmit Buffer Data Field b Register (b = 0 to 4, p = 0 to 31).....	1568
28.4.11.7	RSCFDnCFDTMIECy — Transmit Buffer Interrupt Enable Configuration Register (y = 0).....	1569
28.4.12	Details of Transmit Buffer Status-related Registers	1571
28.4.12.1	RSCFDnCFDTMTRSTSy — Transmit Buffer Transmit Request Status Register (y = 0).....	1571
28.4.12.2	RSCFDnCFDTMTARSTSy — Transmit Buffer Transmit Abort Request Status Register (y = 0)	1573
28.4.12.3	RSCFDnCFDTMTCSTSy — Transmit Buffer Transmit Complete Status Register (y = 0).....	1575
28.4.12.4	RSCFDnCFDTMTASTSy — Transmit Buffer Transmit Abort Status Register (y = 0).....	1577
28.4.13	Details of Transmit Queue-related Registers	1579
28.4.13.1	RSCFDnCFDTXQCCm — Transmit Queue Configuration and Control Register (m = 0, 1).....	1579
28.4.13.2	RSCFDnCFDTXQSTSm — Transmit Queue Status Register (m = 0, 1)	1581
28.4.13.3	RSCFDnCFDTXQPCTRM — Transmit Queue Pointer Control Register (m = 0, 1)	1583
28.4.14	Details of Transmit History-related Registers.....	1584
28.4.14.1	RSCFDnCFDTHLCCm — Transmit History Configuration and Control Register (m = 0, 1).....	1584
28.4.14.2	RSCFDnCFDTHLSTSm — Transmit History Status Register (m = 0, 1).....	1586
28.4.14.3	RSCFDnCFDTHLPCTRM — Transmit History Pointer Control Register (m = 0, 1)	1588
28.4.14.4	RSCFDnCFDTHLACCm — Transmit History Access Register (m = 0, 1).....	1589
28.4.15	Details of Test-related Registers	1591
28.4.15.1	RSCFDnCFDGTSTCFG — Global Test Configuration Register	1591
28.4.15.2	RSCFDnCFDGTSTCTR — Global Test Control Register	1593
28.4.15.3	RSCFDnCFDGLOCKK — Global Lock Key Register	1595
28.4.15.4	RSCFDnCFDRPGACCr — RAM Test Page Access Register (r = 0 to 63).....	1596
28.5	Interrupt Sources and DMA Trigger	1597
28.5.1	Interrupt Sources	1597
28.5.2	DMA Trigger (Only in CANFD Mode).....	1602
28.6	CAN Modes	1603
28.6.1	Global Modes	1604
28.6.1.1	Global Stop Mode	1605
28.6.1.2	Global Reset Mode	1605
28.6.1.3	Global Test Mode	1605
28.6.1.4	Global Operating Mode	1606

28.6.2	Channel Modes	1607
28.6.2.1	Channel Stop Mode	1608
28.6.2.2	Channel Reset Mode	1608
28.6.2.3	Channel Halt Mode	1609
28.6.2.4	Channel Communication Mode	1609
28.6.2.5	Bus Off State	1610
28.6.3	Initializing Registers by Transition to CAN Mode	1611
28.7	Reception Function	1613
28.7.1	Data Processing Using the Receive Rule Table	1613
28.7.1.1	Acceptance Filter Processing	1614
28.7.1.2	DLC Filter Processing	1615
28.7.1.3	Routing Processing	1615
28.7.1.4	Label Addition Processing	1615
28.7.1.5	Mirror Function Processing	1615
28.7.1.6	Timestamp	1616
28.8	Transmission Functions	1617
28.8.1	Transmit Priority Determination	1618
28.8.2	Transmission Using Transmit Buffers	1619
28.8.2.1	Transmit Abort Function	1619
28.8.2.2	One-Shot Transmission Function (Retransmission Disabling Function)	1619
28.8.2.3	Transmit Buffer Merge Mode (Only in CANFD Mode)	1619
28.8.3	Transmission Using FIFO Buffers	1620
28.8.3.1	Interval Transmission Function	1620
28.8.4	Transmission Using Transmit Queues	1623
28.8.5	Transmit Data Padding (Only in CANFD Mode)	1623
28.8.6	Transmit History Function	1624
28.9	Gateway Function	1626
28.9.1	CAN-CANFD Gateway (Only in CANFD Mode)	1626
28.10	Test Function	1627
28.10.1	Standard Test Mode	1627
28.10.2	Listen-Only Mode	1628
28.10.3	Self-Test Mode (Loopback Mode)	1628
28.10.3.1	Self-Test Mode 0 (External Loopback Mode)	1629
28.10.3.2	Self-Test Mode 1 (Internal Loopback Mode)	1629
28.10.4	Restricted Operation Mode (Only in CANFD Mode)	1630
28.10.5	RAM Test	1630
28.10.6	Inter-Channel Communication Test	1630
28.10.6.1	CRC Error Test	1631
28.11	RS-CANFD Setting Procedure	1632
28.11.1	Initial Settings	1632
28.11.1.1	Clock Setting	1634
28.11.1.2	Bit Timing Setting	1634
28.11.1.3	Communication Speed Setting	1636
28.11.1.4	Receive Rule Setting	1638
28.11.1.5	Buffer Setting	1639
28.11.1.6	Transmitter Delay Compensation (Only in CANFD Mode)	1641

28.11.2	Reception Procedure.....	1642
28.11.2.1	Receive Buffer Reading Procedure.....	1642
28.11.2.2	FIFO Buffer Reading Procedure.....	1644
28.11.2.3	FIFO Buffer Reading Procedure by DMA Transfer	1648
28.11.3	Transmission Procedure	1649
28.11.3.1	Procedure for Transmission from Transmit Buffers.....	1649
28.11.3.2	Procedure for Transmission from Transmit/Receive FIFO Buffers	1654
28.11.3.3	Procedure for Transmission from the Transmit Queue	1658
28.11.3.4	Transmit History Buffer Reading Procedure.....	1659
28.11.4	Test Settings.....	1660
28.11.4.1	Self-Test Mode Setting Procedure	1660
28.11.4.2	Procedure for Releasing the Protection	1661
28.11.4.3	RAM Test Setting Procedure.....	1662
28.11.4.4	Inter-Channel Communication Test Setting Procedure.....	1663
28.12	Notes on the RS-CANFD Module	1665
30.	Gigabit Ethernet Interface.....	1667
30.1	Features	1667
30.1.1	Specification	1667
30.1.2	Block Diagram	1668
30.2	External Signal Pins	1669
30.3	Register Configuration	1670
30.3.1	Register Base Address.....	1670
30.3.2	IO Mode Registers.....	1670
30.3.3	DMAC Registers.....	1670
30.3.4	E-MAC Registers.....	1671
30.3.5	TOE Registers	1673
30.4	Register Descriptions	1675
30.4.1	DMAC Registers.....	1675
30.4.1.1	DMAC Mode Register (CCC)	1675
30.4.1.2	Descriptor Base Address Table Register (DBAT)	1677
30.4.1.3	Descriptor Base Address Load Request Register (DLR).....	1678
30.4.1.4	DMAC Status Register (CSR)	1679
30.4.1.5	Current Descriptor Address Register q (CDARq) (q = 0,4)	1681
30.4.1.6	Error Status Register (ESR)	1682
30.4.1.7	Receive Configuration Register (RCR)	1684
30.4.1.8	Reception Truncation Configuration Register I (RTC).....	1685
30.4.1.9	Transmit Configuration Register (TGC).....	1686
30.4.1.10	Transmit Configuration Control Register (TCCR).....	1687
30.4.1.11	Transmit Status Register (TSR)	1689
30.4.1.12	MAC status FIFO Access Register (MFA).....	1690
30.4.1.13	MAC status FIFO Access 2 Register (MFA2).....	1691
30.4.1.14	Descriptor Interrupt Status Register (DIS).....	1692
30.4.1.15	Descriptor Interrupt Control Register (DIC)	1693
30.4.1.16	Descriptor Interrupt Enable Register (DIE).....	1694
30.4.1.17	Descriptor Interrupt Disable Register (DID).....	1695
30.4.1.18	Error Interrupt Status Register (EIS)	1696
30.4.1.19	Error Interrupt Control Register (EIC).....	1698

30.4.1.20	Error Interrupt Enable Register (EIE)	1700
30.4.1.21	Error Interrupt Disable Register (EID)	1701
30.4.1.22	Receive Interrupt Status Register 0 (RIS0)	1702
30.4.1.23	Receive Interrupt Control Register 0 (RIC0)	1703
30.4.1.24	Receive Interrupt Enable Register 0 (RIE0)	1704
30.4.1.25	Receive Interrupt Disable Register 0 (RID0)	1704
30.4.1.26	Receive Interrupt Status Register 1 (RIS1)	1705
30.4.1.27	Receive Interrupt Control Register 1 (RIC1)	1706
30.4.1.28	Receive Interrupt Enable Register 1 (RIE1)	1707
30.4.1.29	Receive Interrupt Disable Register 1 (RID1)	1707
30.4.1.30	Receive Interrupt Status Register 2 (RIS2)	1708
30.4.1.31	Receive Interrupt Control Register 2 (RIC2)	1709
30.4.1.32	Receive Interrupt Enable Register 2 (RIE2)	1710
30.4.1.33	Receive Interrupt Disable Register 2 (RID2)	1711
30.4.1.34	Receive Interrupt Status Register 3 (RIS3)	1712
30.4.1.35	Receive Interrupt Control Register 3 (RIC3)	1713
30.4.1.36	Receive Interrupt Enable Register 3 (RIE3)	1714
30.4.1.37	Receive Interrupt Disable Register 3 (RID3)	1714
30.4.1.38	Transmit Interrupt Status Register (TIS)	1715
30.4.1.39	Transmit Interrupt Control Register (TIC)	1718
30.4.1.40	Transmit Interrupt Enable Register (TIE)	1720
30.4.1.41	Transmit Interrupt Disable Register (TID)	1722
30.4.1.42	Common Interrupt Enable register (CIE)	1724
30.4.1.43	Interrupt Summary Status Register (ISS)	1725
30.4.2	E-MAC Registers	1727
30.4.2.1	E-MAC operating mode register 1 (CXR20)	1727
30.4.2.2	Maximum receive frame length register (CXR2A)	1730
30.4.2.3	Interrupt status register (CXR21)	1731
30.4.2.4	Enables/disables interrupts register (CXR22)	1732
30.4.2.5	PHY register access register (CXR23)	1733
30.4.2.6	Link status register (CXR2B)	1734
30.4.2.7	Polarity set register (CXR2C)	1735
30.4.2.8	In-Band Status set register (CXR31)	1736
30.4.2.9	In-Band Status indicate register (CXR32)	1738
30.4.2.10	Mode indicate register (CXR33)	1739
30.4.2.11	PHY interface select register (CXR35)	1740
30.4.2.12	PHY interface indicate register (CXR36)	1742
30.4.2.13	PAUSE frame register 1 (CXR71)	1743
30.4.2.14	PAUSE frame register 2 (CXR72)	1744
30.4.2.15	PAUSE frame register 3 (CXR8A)	1745
30.4.2.16	PAUSE frame register 4 (CXR80)	1745
30.4.2.17	PAUSE frame register 5 (CXR81)	1746
30.4.2.18	PAUSE frame register 6 (CXR82)	1747
30.4.2.19	E-MAC operating mode register 2 (CXR2D)	1748
30.4.2.20	Software LINK status register (CXR2G)	1749
30.4.2.21	Mac Address register 1 (CXR24)	1750
30.4.2.22	Mac Address register 2 (CXR25)	1750
30.4.2.23	TINT1 counter register (CXR40)	1751
30.4.2.24	TINT2 counter register (CXR41)	1751
30.4.2.25	TINT3 counter register (CXR42)	1752
30.4.2.26	RINT1 counter register (CXR50)	1753
30.4.2.27	RINT2 counter register (CXR51)	1753
30.4.2.28	RINT3 counter register (CXR52)	1754

30.4.2.29	RINT4 counter register (CXR53)	1755
30.4.2.30	RINT5 counter register (CXR54)	1756
30.4.2.31	RINT6 counter register (CXR55)	1756
30.4.2.32	RINT7 counter register (CXR56)	1757
30.4.2.33	RINT8 counter register (CXR57)	1757
30.4.2.34	MDIO status register (MDIOSTS)	1758
30.4.2.35	MDIO command register (MDIOCMD)	1759
30.4.2.36	MDIO address register (MDIOADR)	1759
30.4.2.37	MDIO data register (MDIODAT)	1760
30.4.2.38	MDIO mode register (MDIOMOD)	1761
30.4.2.39	Low Power Mode register 1 (LPTXMOD1)	1762
30.4.2.40	Low Power Mode register 2 (LPTXMOD2)	1763
30.4.2.41	RGMII Low Power parameter register 1 (LPTXGTH1)	1764
30.4.2.42	RGMII Low Power parameter register 2 (LPTXGTH2)	1765
30.4.2.43	RGMII Low Power parameter register 3 (LPTXGTH3)	1766
30.4.2.44	RGMII Low Power parameter register 4 (LPTXGTH4)	1768
30.4.2.45	MII Low Power parameter register 1 (LPTXMTH1)	1769
30.4.2.46	MII Low Power parameter register 2 (LPTXMTH2)	1770
30.4.2.47	MII Low Power parameter register 3 (LPTXMTH3)	1771
30.4.2.48	MII Low Power parameter register 4 (LPTXMTH4)	1772
30.4.3	TOE Registers	1773
30.4.3.1	Checksum operating mode register (CSR0)	1773
30.4.3.2	Tx Frame Checksum Enable register (CSR1)	1775
30.4.3.3	Rx Frame Checksum Enable register (CSR2)	1777
30.4.3.4	Tx Extended Header Number register (CSR3)	1779
30.4.3.5	Rx Extended Header Number register (CSR4)	1780
30.4.3.6	Unsupported Tx Frame Counter register (CSR20)	1781
30.4.3.7	Unsupported Rx Frame Counter register (CSR30)	1782
30.4.3.8	Rx IPv4 Header checksum Error Counter register (CSR31)	1783
30.4.3.9	Rx TCP/UDP/ICMP checksum Error Counter register (CSR32)	1783
30.4.3.10	Filter Operation/Auto Response Enable register (CSFR00)	1784
30.4.3.11	Local IPv4 address register (CSFR01)	1787
30.4.3.12	Local IPv6 address register i (i = 0 to 3) (CSFR02_i)	1787
30.4.3.13	Upper Local MAC address register (CSFR03_U)	1788
30.4.3.14	Lower Local MAC address register (CSFR03_L)	1788
30.4.3.15	IPv6 no_next_header Protocol Number register (CSFR04)	1789
30.4.3.16	Ethernet Type Condition register i (i = 0 to 3) (CSFR10_i)	1789
30.4.3.17	Ethernet Type Condition Enable register (CSFR10)	1790
30.4.3.18	Protocol Condition register i (i = 0 to 3) (CSFR11_i)	1791
30.4.3.19	Protocol Condition Enable register (CSFR11)	1792
30.4.3.20	UDP Por Condition register i (i = 0 to 11) (CSFR12_i)	1794
30.4.3.21	UDP Port Condition Enable register (CSFR12)	1795
30.4.3.22	Upper MAC DA unicast address Condition register (CSFR13_U)	1798
30.4.3.23	Lower MAC DA unicast address Condition register (CSFR13_L)	1798
30.4.3.24	Upper MAC DA broadcast address Condition register (CSFR14_U)	1799
30.4.3.25	Lower MAC DA broadcast address Condition register (CSFR14_L)	1799
30.4.3.26	Upper MAC DA multicast address Condition register i (i = 0 to 19) (CSFR15_U_i)	1800
30.4.3.27	Lower MAC DA multicast address Condition register i (i = 0 to 19) (CSFR15_L_i)	1800
30.4.3.28	MAC DA Condition Enable register (CSFR15)	1801
30.4.3.29	IPv6 analysis Protocol Condition register 0 (CSFR16_0)	1804
30.4.3.30	IPv6 analysis Protocol Condition register 1 (CSFR16_1)	1805

30.4.3.31	IPv6 analysis Protocol Condition register 2 (CSFR16_2)	1806
30.4.3.32	IPv6 analysis Protocol Condition Enable register (CSFR16)	1807
30.4.3.33	Wake Up Interrupt Status register (CSFR20).....	1808
30.4.3.34	Wake Up Interrupt Mask register (CSFR21)	1811
30.4.3.35	Auto Response Configuration register1 (CSFR30)	1814
30.4.3.36	Auto Response Configuration register2 (CSFR31)	1816
30.4.3.37	ARPREQ/Neighbor Solicitations Receive Interrupt Status register (CSFR40) ...	1817
30.4.3.38	ARPREQ/Neighbor Solicitations Receive Interrupt Mask register (CSFR41).....	1818
30.4.3.39	Rx ARPREQ/Neighbor Solicitation Upper MAC SA register (CSFR42_U)	1819
30.4.3.40	Rx ARPREQ/Neighbor Solicitation Lower MAC SA register (CSFR42_L).....	1820
30.4.3.41	Rx ARPREQ/Neighbor Solicitation IP SA register i (i = 0 to 3) (CSFR43_i)	1821
30.5	Operation.....	1822
30.5.1	DMAC Operating Modes	1823
30.5.1.1	Operating Modes	1823
30.5.1.2	How to Set the Operating Mode	1824
30.5.1.3	Operating Mode Transitions Due to Hardware.....	1824
30.5.2	Descriptors	1824
30.5.2.1	Data Representation in URAM	1824
30.5.2.2	Using Descriptor Chains in Queues	1825
30.5.2.3	Descriptor Base Address Table.....	1826
30.5.2.4	Descriptor Chain Processing	1827
30.5.2.5	Descriptor Interrupts	1827
30.5.2.6	Descriptor Type	1828
30.5.2.7	Layout of General Descriptors in the URAM	1830
30.5.2.8	How to Use Frame Data Descriptors.....	1833
30.5.2.9	How to Use Chain Control Descriptors.....	1834
30.5.2.10	How to Use Hardware and Software Arbitration Descriptors	1834
30.5.2.11	Synchronization between Descriptor Access by Hardware and Software	1835
30.5.2.12	Tips for Optimizing Performance in Handling Descriptors	1835
30.5.3	Reception Control.....	1836
30.5.3.1	Reception Queues.....	1837
30.5.3.2	Setting Up Reception Descriptors	1838
30.5.3.3	Reception Processing.....	1840
30.5.4	Transmission Control	1842
30.5.4.1	Setting Up Transmission Descriptors	1843
30.5.4.2	Transmission	1845
30.5.5	Integrity Checking.....	1850
30.5.5.1	Integrity Checking in Reception.....	1850
30.5.5.2	Integrity Checking in Transmission.....	1850
30.5.5.3	Monitoring in Both Reception and Transmission.....	1850
30.5.5.4	Monitoring in Reception.....	1851
30.5.5.5	Monitoring in Transmission.....	1852
30.5.6	Checksum Calculation.....	1853
30.5.6.1	Checksum Calculation handling	1853
30.5.6.2	Error Notification	1854
30.5.6.3	Individually Configuration by the frame type	1854
30.5.6.4	Supported Frame for Checksum Calculation	1857
30.5.6.5	Checksum Calculation Flow	1859
30.5.7	Received Frame Filter	1861
30.5.7.1	Supported Frame for Received Frame Filter.....	1862
30.5.7.2	Received Frame Filtering Flow.....	1866

30.5.7.3	Filtering and Interrupts.....	1873
30.5.8	Auto Response	1875
30.5.8.1	Auto Response Function for ARP REQ.....	1875
30.5.9	Flow Control	1878
30.5.10	Low Power Idle (LPI).....	1879
30.5.11	Control of Reference Clock for Ethernet	1881
30.5.11.1	Stop Procedure of Reference Clock for Ethernet.....	1882
30.5.11.2	Resume Procedure of Reference Clock for Ethernet.....	1883
30.5.12	Interrupts	1885
30.5.12.1	Transmit/Receive Data Management Interrupt	1885
30.5.12.2	Error Management Interrupt	1885
30.5.12.3	Other Management Interrupts	1886
30.5.12.4	E-MAC Interrupt.....	1886
30.5.12.5	TOE Interrupt.....	1886
30.5.12.6	Interrupt	1887
30.5.13	Configuration Procedure	1889
30.5.13.1	Set Up Procedure	1889
30.5.13.2	System Mode Change Procedure (Normal -> Network Standby)	1890
30.5.13.3	System Mode Change Procedure (Network Standby -> Normal)	1891
30.5.13.4	Stop Procedure.....	1892
30.5.14	Connection to PHY-LSI	1893
30.5.14.1	RGMI I Frame Transmission/Reception Timing	1894
30.5.14.2	MII Frame Reception Timing	1895
30.5.14.3	Accessing PHY Registers.....	1896
31.	A/D Converter.....	1904
31.1	Features	1904
31.2	List of Registers	1908
31.3	Register Descriptions	1909
31.3.1	A/D Converter Mode Register 0 (ADM0).....	1909
31.3.2	A/D Converter Mode Register 1 (ADM1).....	1911
31.3.3	A/D Converter Mode Register 2 (ADM2).....	1913
31.3.4	A/D Converter Mode Register 3 (ADM3).....	1914
31.3.5	A/D Converter Interrupt Control Register (ADINT).....	1915
31.3.6	A/D Converter Status Register (ADSTS)	1916
31.3.7	A/D Converter Clock Division Setting Register (ADIVC).....	1917
31.3.8	A/D Converter External Trigger Pin Filter Control Register (ADFIL).....	1918
31.3.9	A/D Conversion Result Registers 3 to 0 (ADCR3 to ADCR0).....	1919
31.4	Operation.....	1921
31.4.1	Types of A/D Conversion Modes.....	1921
31.4.1.1	Trigger Modes.....	1922
31.4.1.2	Operating mode	1923
31.4.1.3	Conversion Mode	1925
31.4.2	Interrupt Functions.....	1926
31.4.3	Procedures of A/D Conversion.....	1927
31.4.3.1	Procedure for Starting A/D Conversion	1928
31.4.3.2	Procedure for Stopping A/D Conversion	1929

31.4.3.3	Procedure for Stopping and Restarting A/D Conversion.....	1930
31.4.3.4	Procedure for Entering Power-saving Mode	1930
31.4.3.5	Procedure for Releasing from Power-saving Mode.....	1931
31.4.3.6	Procedure for a Software Reset	1932
31.4.3.7	Procedure for Restarting A/D Conversion after a Software Reset.....	1933
31.4.3.8	Procedure for Interrupt Processing	1934
31.4.4	Examples of A/D Conversion	1935
31.4.4.1	Example of A/D Conversion in Select Mode with Single Mode Selected.....	1936
31.4.4.2	Example of A/D Conversion in Select Mode with Repeat Mode Selected	1938
31.4.4.3	Example of A/D Conversion in 4-Buffer Mode.....	1940
31.4.4.4	Example of A/D Conversion in Scan Mode with Single Mode Selected.....	1942
31.4.4.5	Example of A/D Conversion in Scan Mode with Repeat Mode Selected.....	1943
31.4.4.6	Example of A/D Conversion in Auto Mode	1944
31.4.4.7	Example of A/D Conversion in Step Mode	1946
31.5	Notes.....	1948
31.5.1	Interval of Hardware Trigger.....	1948
31.5.2	Timing Restrictions.....	1948
31.5.3	Restrictions on ADC_PCLK(P0 ϕ) and ADC_ADCLK(TSU ϕ) Cycles	1948
31.5.4	Operation when Stopping or Restarting A/D Conversion.....	1948
32.	USB2.0.....	1950
32.1	Features	1950
32.1.1	Ch0: USB2.0 OTG/DRD(Host/Function) interface	1950
32.1.2	Ch1: USB2.0 HOST interface.....	1951
32.1.3	Block Diagram	1951
32.1.4	External signal pins	1952
32.1.5	Power and GND pins.....	1952
32.1.6	Interrupt	1953
32.2	Register Configuration	1954
32.2.1	Host controller Register	1954
32.2.2	Function controller Register	1954
32.2.3	USBPHY Control Register.....	1954
32.3	Register Descriptions	1955
32.3.1	Reset register (RESET).....	1955
32.3.2	Clock control register (UCLKCTL).....	1956
32.3.3	Direct power down setting register (UDIRPD).....	1957
32.3.4	VBUSEN control register (VBENCTL).....	1958
32.3.5	Connection control register (CON_CTRL)	1959
32.3.6	Clock status register (CLK_STAT)	1960
32.4	Operation.....	1961
32.4.1	USB/PHY Initialization	1961
32.4.2	Handling of permanently unused pin.....	1962
32.4.2.1	USB/PHY related pins	1962
32.4.2.2	Handling of USB controller related pins	1963
32.4.3	Direct power down (DIRPD).....	1963

32.4.3.1	Enter to Direct power down mode	1963
32.4.3.2	Resume from Direct power down mode	1964
32.5	Usage Notes	1965
32.5.1	Precautions in power down mode	1965
32A.	USB 2.0 Host Module	1966
32A.1	Overview	1966
32A.1.1	Overview	1966
32A.1.2	Features	1966
32A.1.2.1	EHCI v1.1 functions	1967
32A.1.2.2	Link Power Management (LPM) function	1968
32A.1.2.3	OTG function	1969
32A.1.2.4	Battery-charging function	1969
32A.1.2.5	Suspend extension function	1969
32A.1.3	Support of USB-Related Specifications	1970
32A.2	Register Descriptions	1971
32A.2.1	Register Attributes	1971
32A.2.2	Base Address	1971
32A.2.3	Register Overview	1972
32A.2.4	Description of Registers	1974
32A.2.4.1	OHCI Operational Register	1974
32A.2.4.2	EHCI Controller Capability Register	2006
32A.2.4.3	HCI Operational Register	2011
32A.2.4.4	AHB Bridge Register	2028
32A.2.4.5	UCOM Register	2041
32A.3	Clock Signals	2048
32A.3.1	Clock Gating Specifications	2048
32A.3.1.1	Overview of clock gating	2048
32A.3.1.2	Specifications of NONUSE_CLK_MSK operation	2048
32A.3.1.3	Specifications of PERI_CLK_MSK and HOST_CLK_MSK operations	2049
32A.4	Interrupt Sources	2050
32A.4.1	Interrupt Signals	2050
32A.4.2	Interrupt Sources and Control	2051
32A.4.2.1	U2H_INT assertion source and control	2051
32A.4.2.2	U2H_OHCI_INT assertion source and control	2052
32A.4.2.3	U2H_EHCI_INT assertion source and control	2053
32A.4.2.4	U2H_WAKEON_INT assertion source and control	2054
32A.4.2.5	U2H_OBINT assertion source and control	2055
32A.4.3	Timing of De-asserting Interrupt Signals	2056
32A.5	Power-Saving Function	2057
32A.5.1	Controlling the SUSPENDM and SLEEPM Pins of the USBPHY	2057
32A.5.2	Controlling the Clock-Gating Function	2057
32A.6	Battery Charging	2058
32A.6.1	Support of charging port	2058
32A.6.2	Support of portable device	2058

32A.7	Bus Master	2059
32A.7.1	Functional specifications of the bus master	2059
32A.7.1.1	Supported bus master functions.....	2059
32A.7.1.2	Issuing requests for different types of bus transfer	2059
32A.7.1.3	Supported responses	2059
32A.7.1.4	Protection control information.....	2059
32A.7.1.5	Maximum burst length	2060
32A.7.1.6	Boundary of transfer data	2060
32A.7.1.7	Start address of fixed-length INCR burst transfer	2061
32A.8	Overcurrent Control and VBUS Control	2062
32A.8.1	OVRCUR/VBUSEN pin	2062
32A.8.2	Overcurrent detection timer setting	2062
32A.8.3	Port Power (VBUS) control specifications	2063
32A.8.4	Timing Chart for Overcurrent Detection and Recovery	2064
32A.9	Procedure for Setting this Module.....	2065
32A.9.1	Host/Peripheral Common Setting Sequence	2065
32A.9.2	Initialization Sequence	2066
32A.9.3	Flow of Error Handling.....	2067
32B.	USB 2.0 Function Module	2068
32B.1	Overview	2068
32B.1.1	Overview.....	2068
32B.1.2	Features	2068
32B.1.2.1	Peripheral controller supporting high-speed USB	2068
32B.1.2.2	Support of all types of USB transfer	2068
32B.1.2.3	Bus interface.....	2068
32B.1.2.4	Pipe configuration.....	2069
32B.1.2.5	Features of peripheral functions	2069
32B.1.2.6	Features of DMA transfer	2069
32B.1.2.7	Other functions	2070
32B.1.3	Overview of Functions	2071
32B.1.3.1	Automatic recognition of USB transfer speed	2071
32B.1.3.2	USB event.....	2071
32B.1.3.3	USB data transfer	2071
32B.1.3.4	SOF pulse output function	2071
32B.1.4	Restriction matter and Notes.....	2072
32B.1.4.1	Restriction matter.....	2072
32B.1.4.2	Notes	2072
32B.2	Registers	2073
32B.2.1	Base Address	2074
32B.2.2	List of Registers.....	2074
32B.2.3	System Configuration Control Registers	2077
32B.2.3.1	System Configuration Control Register 0 [SYSCFG0] <Address: H'000>	2077
32B.2.3.2	System Configuration Control Register 1 [SYSCFG1] <Address: H'002>	2080
32B.2.4	System Configuration Status.....	2081
32B.2.4.1	System Configuration Status Register (SYSSTS0) <Address: H'004>	2081
32B.2.5	USB Signal Control Registers	2082

32B.2.5.1	Device State Control Register 0 [DVSTCTR0] <Address: H'008>	2082
32B.2.6	Test Mode Register	2084
32B.2.6.1	USB Test Mode Register [TESTMODE] <Address: H'00C>	2084
32B.2.7	FIFO Port Registers	2085
32B.2.7.1	CFIFO Port Register [CFIFO] <Address: H'014>	2085
32B.2.7.2	CFIFO Port Register [CFIFO] <Address: H'016>	2085
32B.2.7.3	CFIFO Port Select Register [CFIFOSEL] <Address: H'020>	2087
32B.2.7.4	D0FIFO Port Select Register [D0FIFOSEL] <Address:H'028> D1FIFO Port Select Register [D1FIFOSEL] <Address:H'02C>	2090
32B.2.7.5	CFIFO Port Control Register [CFIFOCTR] <Address: H'022> D0FIFO Port Control Register [D0FIFOCTR] <Address: H'02A> D1FIFO Port Control Register [D1FIFOCTR] <Address: H'02E>	2092
32B.2.8	Interrupt Enable Registers (INTENBx, BRDYENB, NRDYENB, BEMPENB)	2094
32B.2.8.1	Interrupt Enable Register 0 [INTENB0] <Address: H'030>	2094
32B.2.8.2	BRDY Interrupt Enable Register [BRDYENB] <Address: H'036>	2095
32B.2.8.3	NRDY Interrupt Enable Register [NRDYENB] <Address: H'038>	2096
32B.2.8.4	BEMP Interrupt Enable Register [BEMPENB] <Address: H'03A>	2097
32B.2.9	SOF Control Register	2098
32B.2.9.1	SOF Pin Configuration Register [SOFCFG] <Address: H'03C>	2098
32B.2.10	Interrupt Status	2099
32B.2.10.1	Interrupt Status Register 0 [INTSTS0] <Address: H'040>	2099
32B.2.10.2	BRDY Interrupt Status Register [BRDYSTS] <Address: H'046>	2102
32B.2.10.3	NRDY Interrupt Status Register [NRDYSTS] <Address: H'048>	2105
32B.2.10.4	BEMP Interrupt Status Register [BEMPSTS] <Address: H'04A>	2107
32B.2.11	Frame Number Registers (FRMNUM, UFRMNUM)	2108
32B.2.11.1	Frame Number Register [FRMNUM] <Address: H'04C>	2108
32B.2.11.2	Micro Frame Number Register [UFRMNUM] <Address: H'04E>	2110
32B.2.12	USB Address	2111
32B.2.12.1	USB Address Register [USBADDR] <Address: H'050>	2111
32B.2.13	USB Request Registers	2112
32B.2.13.1	USB Request Type Register [USBREQ] <Address: H'054>	2112
32B.2.13.2	USB Request Value Register [USBVAL] <Address: H'056>	2113
32B.2.13.3	USB Request Index Register [USBINDX] <Address: H'058>	2113
32B.2.13.4	USB Request Length Register [USBLENG] <Address: H'05A>	2114
32B.2.14	DCP Configuration	2115
32B.2.14.1	DCP Configuration Register [DCPCFG] <Address: H'05C>	2115
32B.2.14.2	DCP Max. Packet Size Register [DCPMAXP] <Address: H'05E>	2116
32B.2.14.3	DCP Control Register [DCPCTR] <Address: H'060>	2117
32B.2.15	Pipe Configuration Registers (PIPESEL, PIPECFG, PIPEBUF, PIPEMAXP, PIPEPERI)	2120
32B.2.15.1	Pipe Window Select Register [PIPESEL] <Address: H'064>	2120
32B.2.15.2	Pipe Configuration Register [PIPECFG] <Address: H'068>	2121
32B.2.15.3	Pipe Buffer Setting Register [PIPEBUF] <Address: H'06A>	2127
32B.2.15.4	Pipe Maximum Packet Size Register [PIPEMAXP] <Address: H'06C>	2129
32B.2.15.5	Pipe Cycle Control Register [PIPEPERI] <Address: H'06E>	2130
32B.2.16	Pipe Control Registers (PIPEXCTR)	2133

32B.2.16.1	PIPE1 Control Register [PIPE1CTR] <Address: H'070> PIPE2 Control Register [PIPE2CTR] <Address: H'072> PIPE3 Control Register [PIPE3CTR] <Address: H'074> PIPE4 Control Register [PIPE4CTR] <Address: H'076> PIPE5 Control Register [PIPE5CTR] <Address: H'078>.....	2133
32B.2.16.2	PIPE6 Control Register [PIPE6CTR] <Address: H'07A> PIPE7 Control Register [PIPE7CTR] <Address: H'07C> PIPE8 Control Register [PIPE8CTR] <Address: H'07E> PIPE9 Control Register [PIPE9CTR] <Address: H'080>.....	2139
32B.2.17	Transaction Counters (PIPExTRE)	2141
32B.2.17.1	PIPE1 Transaction Counter Enable Register [PIPE1TRE] <Address: H'090> PIPE2 Transaction Counter Enable Register [PIPE2TRE] <Address: H'094> PIPE3 Transaction Counter Enable Register [PIPE3TRE] <Address: H'098> PIPE4 Transaction Counter Enable Register [PIPE4TRE] <Address: H'09C> PIPE5 Transaction Counter Enable Register [PIPE5TRE] <Address: H'0A0> ...	2141
32B.2.17.2	PIPE1 Transaction Counter Register [PIPE1TRN] <Address: H'092> PIPE2 Transaction Counter Register [PIPE2TRN] <Address: H'096> PIPE3 Transaction Counter Register [PIPE3TRN] <Address: H'09A> PIPE4 Transaction Counter Register [PIPE4TRN] <Address: H'09E> PIPE5 Transaction Counter Register [PIPE5TRN] <Address: H'0A2>	2143
32B.2.18	Low Power Control Register.....	2145
32B.2.18.1	Low Power Control Register [LPCTRL] <Address: H'100>	2145
32B.2.19	Low Power Status Register	2146
32B.2.19.1	Low Power Status Register [LPSTS] <Address: H'102>	2146
32B.2.20	PHY Function Control Register	2147
32B.2.20.1	PHY Function Control Register [PHYFUNCTR] <Address: H'104>	2147
32B.2.21	PHY_OTG Control Register (PHYOTGCTR).....	2148
32B.2.21.1	PHY_OTG Control Register [PHYOTGCTR] <Address: H'10A>	2148
32B.2.22	Peripheral L1 Control Register 1 (PL1CTRL).....	2149
32B.2.22.1	Peripheral L1 Control Register 1 [PL1CTRL1] <Address: H'144>	2149
32B.2.23	Peripheral L1 Control Register 2	2152
32B.2.23.1	Peripheral L1 Control Register 2 [PL1CTRL2] <Address: H'146>	2152
32B.3	Next Register Set	2153
32B.3.1	Next Source Address Register n	2153
32B.3.1.1	Next0 Source Address Register ch0 [N0SA_0] <Address: H'400> Next1 Source Address Register ch0 [N1SA_0] <Address: H'40C> Next0 Source Address Register ch1 [N0SA_1] <Address: H'440> Next1 Source Address Register ch1 [N1SA_1] <Address: H'44C>	2153
32B.3.2	Next Destination Address Register n	2154
32B.3.2.1	Next0 Destination Address Register ch0 [N0DA_0] <Address: H'404> Next1 Destination Address Register ch0 [N1DA_0] <Address: H'410> Next0 Destination Address Register ch1 [N0DA_1] <Address: H'444> Next1 Destination Address Register ch1 [N1DA_1] <Address: H'450>	2154
32B.3.3	Next Transaction Byte Register n.....	2155
32B.3.3.1	Next0 Transaction Byte Register ch0 [N0TB_0] <Address: H'408> Next1 Transaction Byte Register ch0 [N1TB_0] <Address: H'414> Next0 Transaction Byte Register ch1 [N0TB_1] <Address: H'448> Next1 Transaction Byte Register ch1 [N1TB_1] <Address: H'454>.....	2155

32B.4	Current Register Set	2156
32B.4.1	Current Source Address Register	2156
32B.4.1.1	Current Source Address Register ch0 [CRSA_0] <Address: H'418> Current Source Address Register ch1 [CRSA_1] <Address: H'458>	2156
32B.4.2	Current Destination Address Register	2157
32B.4.2.1	Current Destination Address Register ch0 [CRDA_0] <Address: H'41C> Current Destination Address Register ch1 [CRDA_1] <Address: H'45C>	2157
32B.4.3	Current Transaction Byte Register	2158
32B.4.3.1	Current Transaction Byte Register ch0 [CRTB_0] <Address: H'420> Current Transaction Byte Register ch1 [CRTB_1] <Address: H'460>	2158
32B.5	Channel Register Set	2159
32B.5.1	Channel Status Register n	2159
32B.5.1.1	Channel Status Register ch0 [CHSTAT_0] <Address: H'424> Channel Status Register ch1 [CHSTAT_1] <Address: H'464>	2159
32B.5.2	Channel Control Register n	2164
32B.5.2.1	Channel Control Register ch0 [CHCTRL_0] <Address: H'428> Channel Control Register ch1 [CHCTRL_1] <Address: H'468>	2164
32B.5.3	Channel Configuration Register	2167
32B.5.3.1	Channel Configuration Register ch0 [CHCFG_0] <Address: H'42C> Channel Configuration Register ch1 [CHCFG_1] <Address: H'46C>	2167
32B.5.4	Channel Interval Register n	2171
32B.5.4.1	Channel Interval Register ch0 [CHITVL_0] <Address: H'430> Channel Interval Register ch1 [CHITVL_1] <Address: H'470>	2171
32B.5.5	Channel Extension Register n	2172
32B.5.5.1	Channel Extension Register ch0 [CHEXT_0] <Address: H'434> Channel Extension Register ch1 [CHEXT_1] <Address: H'474>	2172
32B.6	Link Register Set	2173
32B.6.1	Next Link Address Register n (NXLA_n)	2173
32B.6.1.1	Next Link Address Register ch0 [NXLA_0] <Address: H'438> Next Link Address Register ch1 [NXLA_1] <Address: H'478>	2173
32B.6.2	Current Link Address Register n (CRLA_n)	2174
32B.6.2.1	Current Link Address Register ch0 [CRLA_0] <Address: H'43C> Current Link Address Register ch1 [CRLA_1] <Address: H'47C>	2174
32B.7	Skip Register Set	2175
32B.7.1	Source Continuous Register n	2175
32B.7.1.1	Source Continuous Register ch0 [SCNT_0] <Address: H'600> Source Continuous Register ch1 [SCNT_1] <Address: H'620>	2175
32B.7.2	Source Skip Register n	2176
32B.7.2.1	Source Skip Register ch0 [SSKP_0] <Address: H'604> Source Skip Register ch1 [SSKP_1] <Address: H'624>	2176
32B.7.3	Destination Continuous Register n	2178
32B.7.3.1	Destination Continuous Register ch0 [DCNT_0] <Address: H'608> Destination Continuous Register ch1 [DCNT_1] <Address: H'628>	2178
32B.7.4	Destination Skip Register n	2179
32B.7.4.1	Destination Skip Register ch0 [DSKP_0] <Address: H'60C> Destination Skip Register ch1 [DSKP_1] <Address: H'62C>	2179

32B.8	DMA Register Set	2181
32B.8.1	DMA Control Register	2181
32B.8.1.1	DMA Control Register [DCTRL] <Address: H'700>.....	2181
32B.8.2	Descriptor Interval Register n.....	2182
32B.8.2.1	Descriptor Interval Register [DSCITVL] <Address: H'704>	2182
32B.8.3	DMA Control Register	2182
32B.8.3.1	DMA Status EN Register [DSTAT_EN] <Address: H'710>	2182
32B.8.4	DMA Status ER Register.....	2183
32B.8.4.1	DMA Status ER Register [DSTAT_ER] <Address: H'714>	2183
32B.8.5	DMA Status END Register	2183
32B.8.5.1	DMA Status END Register [DSTAT_END] <Address: H'718>	2183
32B.8.6	DMA Status TC Register	2184
32B.8.6.1	DMA Status TC Register [DSTAT_TC] <Address: H'71C>	2184
32B.8.7	DMA Status SUS Register	2184
32B.8.7.1	DMA Status SUS Register [DSTAT_SUS] <Address: H'720>	2184
32B.9	Functions.....	2185
32B.9.1	System Control and Oscillation Control.....	2185
32B.9.1.1	USB data bus resistor control.....	2185
32B.9.2	Interrupt Function	2186
32B.9.2.1	Overview of Interrupt Function (other than DMA Master)	2186
32B.9.2.2	Device State Transition Interrupts	2188
32B.9.2.3	Control Transfer Stage Transition Interrupts	2189
32B.9.2.4	Interrupts Relating to DMA Master	2191
32B.9.3	Pipe Control.....	2192
32B.9.3.1	Maximum packet size setting	2193
32B.9.3.2	Response PID.....	2193
32B.9.3.3	Pipe control register switching procedure	2194
32B.9.3.4	Data PID sequence bit.....	2195
32B.9.4	FIFO Buffer.....	2196
32B.9.4.1	FIFO buffer allocation	2196
32B.9.4.2	Clearing FIFO buffers	2197
32B.9.5	FIFO Port Functions	2198
32B.9.5.1	FIFO port selection	2199
32B.9.5.2	DxFIFO automatic clear mode (DxFIFO port read direction)	2200
32B.9.5.3	BRDY interrupt timing selection function.....	2200
32B.9.6	Control Transfer (DCP)	2201
32B.9.6.1	Control transfer.....	2201
32B.9.7	Bulk Transfer (Pipes 1 to 5).....	2203
32B.9.7.1	NYET handshake control.....	2203
32B.9.8	Interrupt Transfer (Pipes 6 to 9)	2204
32B.9.9	Isochronous Transfer (Pipes 1 and 2).....	2205
32B.9.9.1	Isochronous transfer error detection	2205
32B.9.9.2	DATA-PID	2206
32B.9.9.3	Interval counter	2207
32B.9.9.4	Send data setup for isochronous transfer	2208
32B.9.9.5	Transmit buffer flush for isochronous transfer	2209
32B.9.10	SOF Interpolation Function	2211

32B.9.11	Link Power Management Processing.....	2212
32B.9.11.1	Descriptor	2212
32B.9.11.2	Basic processing	2213
32B.9.11.3	HIRD value negotiation.....	2213
32B.9.12	DMA Mode.....	2214
32B.9.12.1	Register mode/link mode	2214
32B.9.12.2	Write only mode.....	2231
32B.9.13	DMA Transfer	2232
32B.9.13.1	Transfer modes.....	2232
32B.9.13.2	DMA channel priority control	2233
32B.9.13.3	Forced sweeping request	2235
32B.9.13.4	DMA transfer completion interrupt (USBFDMAmn).....	2236
32B.9.13.5	DMA error interrupt (USBFDMAERRm).....	2236
32B.9.13.6	Interval Count Function	2237
32B.9.13.7	Operational difference depending on the transfer size	2238
32B.9.13.8	Transfer state.....	2240
32B.9.14	Access Type	2243
32B.9.14.1	DMA master transfer combination list	2243
32B.9.14.2	DMA master descriptor combination list.....	2246
32B.9.15	Arbitration between DMACs	2247
32B.9.16	Notes	2248
32B.9.16.1	Access	2248
32B.9.16.2	Level Interrupt bit.....	2248
40.	SD/MMC Host Interface	2249
40.1	Overview	2249
40.1.1	Features	2249
40.1.2	External Pins	2251
40.1.3	Register Configuration.....	2252
40.2	Register Description	2254
40.2.1	Command Type Register (SD_CMD).....	2254
40.2.2	Command Argument Register (SD_ARG)	2255
40.2.3	Data Stop Register (SD_STOP).....	2256
40.2.4	Block Count Register (SD_SECCNT)	2258
40.2.5	SD Card Response Registers (SD_RSP)	2259
40.2.6	SD Card Interrupt Flag Register (SD_INFO1).....	2261
40.2.7	SD Card Interrupt Flag Register (SD_INFO2).....	2264
40.2.8	SD_INFO1 Interrupt Mask Register (SD_INFO1_MASK).....	2268
40.2.9	SD_INFO2 Interrupt Mask Register (SD_INFO2_MASK).....	2269
40.2.10	SD Clock Control Register (SD_CLK_CTRL)	2270
40.2.11	Transfer Data Length Register (SD_SIZE)	2272
40.2.12	SD Card Access Control Option Register (SD_OPTION).....	2273
40.2.13	SD Error Status Register 1 (SD_ERR_STS1).....	2274
40.2.14	SD Error Status Register 2 (SD_ERR_STS2).....	2275
40.2.15	SD Buffer Read/Write Register (SD_BUF0).....	2275
40.2.16	SDIO Mode Control Register (SDIO_MODE)	2276

40.2.17	SDIO Interrupt Flag Register (SDIO_INFO1).....	2278
40.2.18	SDIO_INFO1 Interrupt Mask Register (SDIO_INFO1_MASK)	2279
40.2.19	DMA Mode Enable Register (CC_EXT_MODE)	2280
40.2.20	Software Reset Register (SOFT_RST)	2280
40.2.21	Version Register (VERSION)	2281
40.2.22	Host Interface Mode Setting Register (HOST_MODE).....	2281
40.2.23	SD Interface Mode Setting Register (SDIF_MODE)	2282
40.2.24	SD Status Register (SD_STATUS).....	2282
40.2.25	DMAC Transfer Mode Register (DM_CM_DTRAN_MODE).....	2283
40.2.26	DMAC Transfer Control Register (DM_CM_DTRAN_CTRL).....	2283
40.2.27	DMAC Reset Register (DM_CM_RST).....	2284
40.2.28	DMAC Interrupt Register 1 (DM_CM_INFO1).....	2285
40.2.29	DM_CM_INFO1 Interrupt Mask Register (DM_CM_INFO1_MASK)	2286
40.2.30	DMAC Interrupt Register 2 (DM_CM_INFO2).....	2287
40.2.31	DM_CM_INFO2 Interrupt Mask Register (DM_CM_INFO2_MASK)	2288
40.2.32	DMAC Transfer Address Register (DM_DTRAN_ADDR).....	2288
40.3	Operation.....	2289
40.3.1	SD Interface.....	2289
40.3.2	Card Detect/Write Protect	2293
40.3.3	Interrupt Request.....	2295
40.3.4	Communications Errors and Timeouts.....	2296
40.4	Usage Example.....	2298
40.4.1	Command without Data Transfer	2298
40.4.2	Single Block Read	2301
40.4.3	Single Block Write	2303
40.4.4	Multiple Block Read.....	2305
40.4.5	Multiple Block Write (when Using Internal Timer)	2307
40.4.6	Multiple Block Write (when Using External Timer).....	2309
40.4.7	IO_RW_DIRECT Command (CMD52).....	2311
40.4.8	IO_RW_EXTENDED (CMD53/Multiple Block Read)	2312
40.4.9	IO_RW_EXTENDED (CMD53/Multiple Block Write).....	2314
40.4.10	DMA Transfer	2316
40.4.11	High-Priority Interrupt (without Data Transfer)	2318
40.4.12	High-Priority Interrupt (at Single Block Write)	2320
40.4.13	High-Priority Interrupt (at Multiple Block Write).....	2322
40.4.14	Example of SD_CMD Register Setting	2326
40.5	Usage Notes.....	2329
40.6	Sampling Clock Controller (SCC).....	2332
40.6.1	Features	2332
40.6.2	SCC Block Diagram.....	2332
40.6.3	SCC Register Configuration	2333

40.7	SCC Register Descriptions	2334
40.7.1	Initial Setting Register (SCC_DTCNTL).....	2334
40.7.2	Sampling Clock Position Setting Register (SCC_TAPSET).....	2334
40.7.3	Sampling Clock Selection Register (SCC_CKSEL).....	2334
40.7.4	Sampling Clock Position Correction Register (SCC_RVSCNTL)	2335
40.7.5	Sampling Clock Position Correction Request Register (SCC_RVSREQ).....	2335
40.7.6	Hardware Adjustment Register 1 (SCC_DT2FF).....	2336
40.7.7	Sampling data comparison register (SCC_SMPCMP).....	2336
40.7.8	Hardware adjustment register 2 (SCC_TMPPORT)	2337
40.8	Usage Example of SCC	2338
40.8.1	Tuning.....	2338
40.8.2	Sampling Clock Position Correction after Tuning.....	2341
40.8.3	Change point of the input data	2343
41.	General Purpose Input Output Port (GPIO).....	2344
41.1	Features	2344
41.1.1	General Purpose Input Output Port (GPIO)	2344
41.1.2	Port Function Control	2344
41.1.3	Special Purpose Port Function Control	2345
41.1.4	General Purpose Input Output Port Configuration	2346
41.1.5	Special purpose port Configuration	2351
41.2	Register Configuration	2358
41.2.1	Port Register (Pn).....	2358
41.2.2	Port Mode Register (PMn).....	2359
41.2.3	Port Mode Control Register (PMCn)	2359
41.2.4	Port Function Control Register (PFCm)	2360
41.2.5	Port Input Register (PINn).....	2361
41.2.6	Interrupt Enable Control Register (ISEL)	2361
41.2.7	Driving Ability Control Register (IOLH).....	2362
41.2.8	Slew Rate Switching Register (SR).....	2363
41.2.9	Pull Up/Pull down Switching Register (PUPD).....	2363
41.2.10	Write protected register (PWPR).....	2364
41.2.11	Digital Noise Filter Switching Register (FILONOFF).....	2364
41.2.12	Digital Noise Filter Number Register (FILNUM)	2366
41.2.13	Digital Noise Filter Clock Selection Register (FILCLKSEL)	2367
41.2.14	Ether ch0 IO Voltage Mode Control Register (ETH_ch0)	2368
41.2.15	Ether ch1 IO Voltage Mode Control Register (ETH_ch1)	2368
41.2.16	Ether MII/RGMII Mode Control Register (ETH MII/RGMII)	2368
41.2.17	SD ch0 IO Voltage Mode Control Register (SD_ch0).....	2368
41.2.18	SD ch1 IO Voltage Mode Control Register (SD_ch1).....	2369
41.2.19	QSPI IO Voltage Mode Control Register (QSPI).....	2369
41.2.20	Input Enable Control Register (IEN).....	2369

41.3	Register Descriptions	2370
41.3.1	Port Register (Pn).....	2370
41.3.2	Port Mode Register (PMn).....	2372
41.3.3	Port Mode Control Register (PMCn)	2374
41.3.4	Port Function Control Register (PFCm)	2376
41.3.5	Port Input Register (PINn).....	2378
41.3.6	Interrupt Enable Control Register (ISEL)	2380
41.3.7	Driving Ability Control Register (IOLH).....	2382
41.3.8	Slew Rate Switching Register (SR).....	2384
41.3.9	Pull Up/Pull down Switching Register (PUPD).....	2386
41.3.10	Write protected register (PWPR).....	2388
41.3.11	Digital Noise Filter Switching Register (FILONOFF).....	2389
41.3.12	Digital Noise Filter Number Register (FILNUM)	2391
41.3.13	Digital Noise Filter Clock Selection Register (FILCLKSEL)	2393
41.3.14	Ether ch0 Voltage Mode Control Register (ETH_ch0)	2398
41.3.15	Ether ch1 Voltage Mode Control Register (ETH_ch1)	2399
41.3.16	Ether MII/RGMII Mode Control Register (ETH MII/RGMII)	2400
41.3.17	SD ch0 IO Voltage Mode Control Register (SD_ch0)	2401
41.3.18	SD ch1 IO Voltage Mode Control Register (SD_ch1)	2402
41.3.19	QSPI IO Voltage Mode Control Register (QSPI).....	2403
41.3.20	Input Enable Control Register (IEN).....	2404
41.4	Operation.....	2405
41.4.1	Operation for GPIO Function.....	2405
41.4.2	Operation for Peripheral Function	2405
42.	Low Power Mode.....	2406
42.1	Overview	2406
42.2	Module Standby Mode	2407
42.2.1	Overview.....	2407
42.2.2	Operation.....	2409
42.2.2.1	Setting of Clock control and MSTOP register.....	2410
43.	Debug Interface	2412
43.1	Overview	2412
43.1.1	Features	2412
43.1.2	External Pins	2413
43.1.3	Treatment of Unused Pins.....	2415
43.2	Address Space.....	2416
43.2.1	Debug Module (Access from System Bus)	2416
43.2.2	Debug Module (Access from DTM).....	2416
43.2.3	System Bus Access (Access from DM).....	2416
43.3	Register Descriptions	2417
43.3.1	ID Register (BSID).....	2417

43.3.2	Debug Module Registers	2417
43.4	Debug Connection	2418
43.4.1	Debug Connection Mode.....	2418
43.5	Debug Access Range	2418
43.6	Operation.....	2419
43.6.1	Debug Related Reset	2419
43.6.2	WDT Counter Stop Control	2419
43.6.3	GTM Counter Stop Control.....	2419
44.	Thermal Sensor Unit (TSU).....	2420
44.1	Overview	2420
44.1.1	Features	2420
44.1.2	Block Diagram	2421
44.1.2.1	APB_REG.....	2422
44.1.2.2	Thermal Sensor	2422
44.1.2.3	DIV40_TS and DIV10_TS	2422
44.1.2.4	SOC_TS_GEN.....	2422
44.1.2.5	EOC_SY_TS.....	2422
44.1.2.6	Read Buffer (RB).....	2422
44.1.3	External Pins	2423
44.1.4	Interrupts	2423
44.2	Register Configuration	2424
44.2.1	List of Register.....	2424
44.3	Register Descriptions	2425
44.3.1	Sensor Mode Register (TSU_SM).....	2425
44.3.2	Sensor Trigger Register (TSU_ST).....	2426
44.3.3	Sensor ADC Data Register (TSU_SAD)	2427
44.3.4	Sensor Status Register (TSU_SS).....	2428
44.3.5	TSU OTP Calibration Register 0 (OTPTSUTRIM0_REG)	2429
44.3.6	TSU OTP Calibration Register 1 (OTPTSUTRIM1_REG)	2430
44.4	Operation.....	2431
44.4.1	Procedure for Starting the A/D Conversion	2431
44.4.2	Procedure for Stopping the A/D Conversion	2431
44.4.3	Confirming the State of the A/D Conversion by Monitoring the CONV Bit.....	2432
44.4.4	Procedure for Measuring the Temperature	2432
44.5	Usage Note	2433
45.	Trusted Secure IP	2434
45.1	Overview	2434
45.2	Operation.....	2437
45.2.1	Operating Modes and State Transitions.....	2437
45.2.2	Encryption Engine	2438
45.2.3	Key Installation	2439

45.2.4	Encryption and Decryption	2441
45.2.5	Generating Key Generation Information (by Using Random Numbers).....	2444
45.2.6	Random Number Generation	2444
45.3	Interrupt.....	2445
45.4	Usage Notes.....	2446
45.4.1	Trusted Secure IP Driver.....	2446
48.	Electrical Characteristics	2447
48.1	Absolute Maximum Ratings	2447
48.2	Power Supply	2448
48.3	Power-On/Power-Off Sequence.....	2449
48.4	DC Characteristics	2451
48.5	AC Characteristics	2458
48.5.1	Clock Timing.....	2458
48.5.2	SDHI Access Timing	2460
48.5.2.1	SDHI Access Timing (SDR 3.3-V).....	2460
48.5.3	eMMC Access Timing	2461
48.5.3.1	eMMC Host Interface Timing (Default).....	2461
48.5.3.2	eMMC host interface timing (HS-SDR)	2462
48.5.3.3	eMMC host interface timing (HS200)	2463
48.5.4	USB 2.0 Host/Function Module Access Timing	2464
48.5.4.1	USB 2.0 Low-Speed Access Timing	2464
48.5.4.2	USB 2.0 Full-Speed Access Timing	2465
48.5.4.3	USB 2.0 Hi-Speed Access Timing.....	2466
48.5.5	Ethernet Interface Access Timing	2467
48.5.5.1	Ethernet-IF (Ether MII).....	2468
48.5.5.2	Ethernet-IF (Ether RGMII)	2469
48.5.6	JTAG Debugger Interface Access Timing	2471
48.5.7	SPI Multi I/O Bus Controller Access Timing.....	2473
48.5.8	Control Signal Access Timing	2476
48.5.9	Serial Sound Interface (SSIF-2) Access Timing.....	2478
48.5.10	CAN-FD Interface Access Timing	2480
48.5.11	Multi-Function Timer Pulse Unit 3 (MTU3a) Access Timing	2481
48.5.12	Port Output Enable 3 (POE3) Access Timing	2482
48.5.13	I ² C Bus Interface Access Timing	2483
48.5.14	Serial Communications Interface with FIFO (SCIFA) Access Timing	2485
48.5.15	Serial Communications Interface (SCIg) Access Timing	2487
48.5.16	Renesas Serial Peripheral Interface (RSPI) Access Timing	2489
48.5.17	A/D Converter Access Timing	2492
48.5.18	Watchdog Timer Access Timing.....	2492
Appendix A	Package Dimensions	2493

1. Overview

1.1 Introduction

The RZ/Five includes:

- 1.0 GHz AndesCore™ AX45MP Single Core core,
- Memory controller for DDR4-1600 / DDR3L-1333 with 16 bits,
- USB2.0 host / function interface,
- Gigabit Ethernet interface,
- SD card host interface,
- CAN interface,
- Sound interface

NOTE

- AndesCore is registered trademark of Andes Technology Corporation. All other brands or product names are the property of their respective holders.
- This LSI does not support TrustZone.
- There are 2 types in RZ/Five.

Group	Part Number	Part differentiator	Package	Note
RZ/Five	R9A07G043F01GBG	Full featured, Gigabit Ethernet Interface 2 channels	361-pin BGA, 13-mm square, 0.5-mm pitch	Package compatible with RZ/G2UL (Type-1)
	R9A07G043F00GBG	Full featured, Gigabit Ethernet Interface 1 channel	266-pin BGA, 11-mm square, 0.5-mm pitch	—

1.2 List of Specifications

1.2.1 CPU Core

Item	Description
System CPU AX45MP	<p>[RZ/Five]</p> <ul style="list-style-type: none"> • AndesCore™ AX45MP Single core 1.0 GHz • L1 I-cache 32 Kbytes (Parity) / D-cache 32 Kbytes (ECC) • ILM 64 Kbytes (ECC) / DLM 64 Kbytes (ECC), Total 128 Kbytes*1 • L2 cache 256 KBytes (ECC) • Floating point extension DSP/SIMD ISA • AndeStar™ V5 Instruction Set Architecture (ISA) <p><i>Note 1.</i> The ILM and DLM are generally not used in Linux. Please refer also AndesCoreAX45MP-1C Processor Reference Manual for details.</p>
Boot	<p>[RZ/Five]</p> <ul style="list-style-type: none"> • 6 boot modes <p>Boot Mode 0: Booting from eSD</p> <p>Boot Mode 1: Booting from eMMC (1.8 V)</p> <p>Boot Mode 2: Booting from eMMC (3.3 V)</p> <p>Boot Mode 3: Booting from a serial flash memory (Single / Quad) connected to the SPI Multi I/O bus space (1.8 V)</p> <p>Boot Mode 4: Booting from a serial flash memory (Single / Quad) connected to the SPI Multi I/O bus space (3.3 V)</p> <p>Boot Mode 5: Booting from SCIF download</p>
Debug Interface	<p>[RZ/Five]</p> <ul style="list-style-type: none"> • AndesCore™ AX45MP Debug Subsystem • JTAG interface supported • Embedded Debug Module with up to 8 triggers

1.2.2 CPU Peripheral

Item	Description
Clock Pulse Generator (CPG)	[RZ/Five] <ul style="list-style-type: none"> Generates the clocks from external clock (EXCLK 24 MHz). <ul style="list-style-type: none"> Maximum AndesCore™ AX45MP Single core clock: 1.0 GHz Maximum DDR clock: 666 MHz (DDR3L-1333), 800 MHz (DDR4-1600) Maximum AXI-bus clock: 200 MHz Maximum APB-bus clock: 100 MHz SSC (Spread Spectrum Clock) supported
Direct Memory Access Controller (DMAC)	[RZ/Five] <ul style="list-style-type: none"> 2 modules, 16 channels per module Transfer request: On-chip peripheral request / auto request (software trigger) A specific DMA transfer interval can be specified to adjust the bus occupancy. LINK mode (DMA transfer under descriptor control) supported Transfer information can be automatically reloaded
Platform-Level Interrupt Controller (PLIC)	[RZ/Five] <ul style="list-style-type: none"> Andes Platform-Level Interrupt Controller 255 priority levels available Software-programmable interrupt generation External Interrupt pins (NMI, IRQ7 to IRQ0, TINT31-0) On-chip peripheral Interrupts: priority level set for each module
General-purpose I/O (GPIO)	[RZ/Five] <ul style="list-style-type: none"> General-purpose I/O ports
Thermal Sensor Unit (TSU)	[RZ/Five] <ul style="list-style-type: none"> 1 channel

1.2.3 Internal Memory

Item	Description
System RAM	[RZ/Five] <ul style="list-style-type: none"> RAM of 128 Kbytes (ECC)

1.2.4 External Memory Interface

Item	Description
External Bus Controller for DDR3L / DDR4 SDRAM (DDR)	[RZ/Five] <ul style="list-style-type: none"> • Support DDR3L-1333 / DDR4-1600 • Bus Width: 16-bit • In line ECC supported (Support error detection interrupt) • Memory Size: Up to 4 Gbytes • Auto Refresh supported
SPI Multi I/O Bus Controller	[RZ/Five] <ul style="list-style-type: none"> • 1 channel (4-bit Double data rate) • 1 serial flash memory with multiple I/O bus sizes (single / quad) can be connected • External address space read mode (built-in read cache) • SPI operation mode • Maximum Clock Frequency: <ul style="list-style-type: none"> – 50 MHz (Quad-SPI DDR) – 66 MHz (Quad-SPI SDR)
SD Card Host Interface / Multimedia Card Interface (SD/MMC)	[RZ/Five] <ul style="list-style-type: none"> • 2 channels • Channel 0 supports SDHI / e-MMC (boot supported) • Channel 1 supports SDHI • SD memory I/O card interface (1-bit / 4-bit SD bus) • SD, SDHC and SDXC SD memory card access supported • Compliant with SD 3.0 • Default, high-speed, UHS-I/SDR50, SDR104 transfer modes supported • Error check function: CRC7 (Command), CRC16 (Data) • Card detection function, write protect supported • MMC interface (1-bit / 4-bit / 8-bit MMC bus) • e-MMC device access supported • Compliant with eMMC 4.51 • High-speed, HS200 transfer modes supported

1.2.5 Sound Interface

Item	Description
Serial Sound Interface (SSI)	[RZ/Five] <ul style="list-style-type: none"> • 4 channels bidirectional serial transfer • 2 external clock sources available • Duplex communication (channel 0, 1, and 3) • Support of I2S / Monaural / TDM audio formats • Support of master and slave functions • Generation of programmable word clock and bit clock • Multi-channel formats • Support of 8, 16, 18, 20, 22, 24, and 32-bit data formats • Support of 32-stage FIFO for transmission and reception • Support of LR-clock continue function in which the LR-clock signal is not stopped

1.2.6 Storage and Network

Item	Description
USB2.0 Host / Function (USB)	[RZ/Five] <ul style="list-style-type: none"> • 2 channels (ch0: Host-Function ch1: Host only) • Compliance with USB2.0 • Supports On-The-Go (OTG) Function • Supports Battery Charging Function • Internal dedicated DMA
Gigabit Ethernet Interface (GbE)	[RZ/Five] <ul style="list-style-type: none"> • Number of channels <ul style="list-style-type: none"> – 2 channels: Support by 361-pin BGA – 1 channel: Support by 266-pin BGA • Supports transfer at 1000 Mbps and 100 Mbps, 10 Mbps • Supports filtering of Ethernet frames • Supports interface conforming to IEEE802.3 PHY RGMII (Reduced Gigabit Media Independent Interface) • Supports interface conforming to IEEE802.3 PHYMII (Media Independent Interface)
Controller Area Network Interface (CAN)	[RZ/Five] <ul style="list-style-type: none"> • 2 channels • ISO 11898-1 (2003) compliant • CAN-FD ISO 11898-1 (CD2014) compliant • Message buffer <ul style="list-style-type: none"> – Up to 64 × 2-channel receive message buffer: Shared among all channels – 16 transmit message buffers per channel

1.2.7 Timer

Item	Description
Multi-function Timer Pulse Unit 3 (MTU3a)	<p>[RZ/Five]</p> <ul style="list-style-type: none"> • 9 channels (16 bits × 8 channels, 32 bits × 1 channel) • Module clock frequency (P0φ): 100 MHz • Maximum 28 lines of pulse inputs/outputs and 3 lines of pulse inputs • 14 types of count clocks selectable • Input capture function • 39 outputs compare and input capture registers • Counter clear operation (Simultaneous counter clearing by Compare match or Input capture is available) • Simultaneous writing to multiple timer counters (TCNT) • Synchronous input/output of each register due to synchronous operation of the counter • Buffered operation • Cascade-connected operation • 43 types of interrupt sources • Automatic transfer of register data • Pulse output modes <ul style="list-style-type: none"> Toggle, PWM, complementary PWM, and reset-synchronized PWM modes • Synchronization of multiple counters • Phase counting mode <ul style="list-style-type: none"> – 16-bit mode (channel 1 and 2) – 32-bit mode (channel 1 and 2) • Counter function of dead time compensation • Digital filter functions for the input capture and external count clock pin
Port Output Enable 3 (POE3)	<p>[RZ/Five]</p> <ul style="list-style-type: none"> • Control of the high-impedance state of the MTU3a waveform output pins • Activation with four input pins • Activation on detection of short-circuited outputs • Activation by register write • Additional programming of output control target pins is possible.
Watchdog Timer (WDT)	<p>[RZ/Five]</p> <ul style="list-style-type: none"> • 1 channel • A counter overflow can reset the LSI • CPU parity error can reset the LSI
General Timer (GTM)	<p>[RZ/Five]</p> <ul style="list-style-type: none"> • 32 bits × 3 channels • Two operating modes <ul style="list-style-type: none"> – Interval timer mode – Free-running comparison mode

1.2.8 Peripheral Module

Item	Description
I2C Bus Interface (I2C)	[RZ/Five] <ul style="list-style-type: none"> • 4 channels (ch0,1 = Dedicated pin, ch2,3 = Multiplexed pin) • Master mode and slave mode supported • Support for 7-bit and 10-bit slave address formats • Support for multi-master operation • Timeout detection
Serial Communication Interface with FIFO (SCIFA)	[RZ/Five] <ul style="list-style-type: none"> • 5 channels • Clock synchronous mode or asynchronous mode selectable • Simultaneous transmission and reception (full-duplex communication) supported • Dedicated baud rate generator • Separate 16-byte FIFO registers for transmission and reception • Modem control function (channel 0, 1, and 2 in asynchronous mode)
Serial Communication Interface (SCI)	[RZ/Five] <ul style="list-style-type: none"> • 2 channels • Clock synchronous mode, asynchronous mode, or smart card interface mode is selectable • Simultaneous transmission and reception (full-duplex communication) supported • Dedicated baud rate generator • LSB first / MSB first selectable • Modem control function • Encoding and decoding of IrDA communications waveforms in accord with version 1.0 of the IrDA standard (on channel 0)
Renesas Serial Peripheral Interface (RSPI)	[RZ/Five] <ul style="list-style-type: none"> • 3 channels • SPI operation • Master mode and slave mode supported • Programmable bit length, clock polarity, clock phase can be selected • Consecutive transfers • LSB first / MSB first selectable

1.2.9 Security

Item	Description
Trusted Secure IP (TSIP) [option]	[RZ/Five] <ul style="list-style-type: none"> • Security algorithm <ul style="list-style-type: none"> – Common key encryption: AES – Non-common key encryption: RSA, ECC • Other features <ul style="list-style-type: none"> – TRNG (true-random number generator) – Hash value generation: SHA-1, SHA-224, SHA-256, GHASH – Support of Unique ID
One Time Programmable memory (OTP)	[RZ/Five] <ul style="list-style-type: none"> • A nonvolatile memory that can be written only once • Security setting, authentication setting are possible • Support one time read function (128 bytes)

1.2.10 Analog

Item	Description
A/D Converter (ADC)	[RZ/Five] <ul style="list-style-type: none"> • 2 channels • Resolution: 12-bit • Input Range: 0 V ~ 1.8 V • Conversion Time: 1 μs • Operation Mode: Single Scan / Continuous Scan • Condition for A/D conversion start <ul style="list-style-type: none"> – Software trigger – Asynchronous trigger: External trigger supported – Synchronous trigger: MTU timer

1.2.11 Others

Item	Description
Boundary Scan	[RZ/Five] <ul style="list-style-type: none"> • Boundary scan based on IEEE 1149.1 via JTAG interface is supported. Note that some module pins are not available on this boundary scan.

1.2.12 Power Supply Voltage

Item	Description
Power supply voltage	[RZ/Five] <ul style="list-style-type: none"> • V_{DD}, PLLn_DV_{DD11} (n = 23, 5): 1.05 to 1.15 V • DDR_V_{DD0}: 1.14 to 1.26 V (DDR4) / 1.283 to 1.45 V (DDR3L) • V_{DD18}, ADC_AV_{DD18}, PLLn_AV_{DD18} (n = 1, 23, 4, 5, 6): 1.62 to 1.98 V • OTP_V_{DD18}, USB_V_{DD18}: 1.65 to 1.95 V • PV_{DD}: 2.97 to 3.63 V • USB_V_{DD33}: 3.00 to 3.60 V • SDn_PV_{DD} (n = 0, 1), SPI_PV_{DD}: 2.97 to 3.63 V / 1.70 to 1.95 V • PV_{DD182533}: 2.97 to 3.63 V / 2.25 to 2.75 V / 1.62 to 1.98 V

1.2.13 Temperature Range

Item	Description
Temperature range	[RZ/Five] <ul style="list-style-type: none"> • T_a: -40°C to +85°C*1 • T_j: -40°C to +125°C

Note 1. If wider temp is required than this range, use case has to be investigated.

1.2.14 Quality level

Item	Description
Quality level	[RZ/Five] <ul style="list-style-type: none">• Industrial usage, etc.

1.2.15 Package

Item	Description
Package	[RZ/Five] <ul style="list-style-type: none">• 361-pin LFBGA, 13-mm square, 0.5-mm pitch• 266-pin LFBGA, 11-mm square, 0.5-mm pitch

1.3 Product Lineup

Table 1.1 Product Lineup

Group	Package	Part Number	Security*1
RZ/Five	13 mm BGA	R9A07G043F05GBG	Available
		R9A07G043F01GBG	Not supported
	11 mm BGA	R9A07G043F04GBG	Available
		R9A07G043F00GBG	Not supported

Note 1. The product with security function supports the following features.

- Trusted Secure IP
- Secure Boot
- Secure Debug
- HW Key protection
- True Random Generator

1.4 Pin

This section describes the pins of this LSI.

1.4.1 Pin Assignment

Refer to attached excel file for the “ball view” about pin assignment of this LSI.

(Please double-click the icon on the right side) 

1.4.2 External Pins and Multiplexed Functional Pins

Refer to attached excel file for the “pn function list” about information of external pins and multiplexed functional pins of this LSI.

(Please double-click the icon on the right side) 

2. System CPU AX45MP

The AX45MP system CPU is a core block equipped with single AX45MP core. For details on the functions including interrupts of the AX45MP, see the AndesCore™ AX45MP-1C Processor Reference Manual. For details of interrupt type and control, see the chapter on Interrupt Controller. For details on clock and the controls, see the chapter on the clock pulse generator (CPG).

2.1 Features

Table 2.1 Function Summary

	Description
CPU	<ul style="list-style-type: none"> AndesCore™ AX45MP Version 5.0.0 Single core 1.0 GHz ILM 64 Kbytes (ECC) / DLM 64 Kbytes (ECC), Total 128 Kbytes Floating point extension DSP/SIMD ISA AndeStar™ V5 Instruction Set Architecture (ISA)
Cache memory	<ul style="list-style-type: none"> L1\$ (I/D) = 32 KB(Parity) / 32 KB (ECC) L2\$ = 256 KB (ECC)

Table 2.2 Core Configuration (1/2)

	Value	Description
Cluster Configuration		
Core Number	1	Number of cores.
L2C Cache Size	256 KB	Size of the L2-Cache memory.
L2C Soft Error Protection	ECC	L2-Cache RAMs are protected by ECC.
L2C Performance Counter Number	8	Built-in hardware performance counters for debugging or performance analysis purposes.
I/O Coherence Port	0	Number of I/O coherent ports.
ISA		
RISC-V Floating-Point Instruction Extension	Double precision	Supports single and double precision.
RISC-V P-extension (draft) DSP/SIMD ISA	Yes	RISC-V "P" Extension for DSP (Digital Signal Processing) instructions.
Privilege Architecture		
Page-Based Virtual Memory	Sv39	Supervisor mode and Sv39 virtual address translation scheme.
Number of Shared TLB Entries	512	Number of supported Shared TLB entries.
Number of iTLB Entries	8	Number of supported iTLB entries.
Number of dTLB Entries	8	Number of supported dTLB entries.
Number of PMP Entries	16	Number of supported PMP entries.
Performance Monitors	Yes	Enables hardware performance monitors.
RISC-V User-Level Interrupt Extension	Yes	Enables the RISC-V User-Level Interrupt Extension.
Andes Vectored PLIC Extension	Yes	Enables the Andes Vectored PLIC extension for reducing interrupt latency.
Andes StackSafe Extension	Yes	Enables the StackSafe hardware stack protection extension.
Andes PowerBrake Extension	Yes	Enables the PowerBrake power/performance scaling extension.

Table 2.2 Core Configuration (2/2)

	Value	Description
Local Memory		
ILM Size	64 KB	Size of the instruction local memory.
ILM Soft Error Protection	ECC	Soft-error protection scheme.
DLM Size	64 KB	Size of the data local memory.
DLM Soft Error Protection	ECC	Soft-error protection scheme.
Slave Port Support	No	Bus masters cannot access the local memories of AX45MP.
Cache Configuration		
I-Cache Size	32KB	Size of the instruction cache.
I-Cache Associativity	2-way	Associativity of instruction cache.
I-Cache Replacement Policy	Pseudo-lru	Replacement policy of instruction cache on cache misses.
I-Cache Soft Error Protection	Parity	Soft-error protection scheme.
D-Cache Size	32 KB	Size of the data cache.
D-Cache Associativity	4-way	Associativity of data cache.
D-Cache Replacement Policy	Pseudo-lru	Replacement policy of data cache when cache miss.
D-Cache Soft Error Protection	ECC	Soft-error protection scheme.
D-Cache Outstanding Misses	8	Maximum number of outstanding D-Cache misses.
D-Cache Prefetch Support	Yes	Enables the D-Cache hardware prefetcher support.
D-Cache Write-Around Support	Yes	Enables the D-Cache Write-Around support.
Debug and Trace		
Debug Support	Yes	Enables the core debug support.
Number of Triggers	8	Number of hardware breakpoints.
Trace Interface	None	Trace interface is not supported.
Physical Memory Attributes		
Number of Programmable PMA Entries	16	Number of Programmable PMA Entries.

2.2 Reset

Reset address vector can be set by below Reset Vector Address Configuration Registers. For details, see the chapter of System Controller.

AX45MP Core0 Reset Vector Address High/Low Configuration Register:

SYS_AX45MP_CFG_RVAH0 / SYS_AX45MP_CFG_RVAL0

To change reset vector address, follow the procedure below.

1. Store codes to new reset address.
2. Write the new reset address to AX45MP Reset Vector Address Configuration Registers.
3. Issue reset.

2.2.1 Cold Reset

A cold reset is applied at any of the following cases.

- (a) The sequence of a power-on reset by the CPG is executed.
- (b) The WDT counter has overflowed or a non-correctable error has been detected.

For details on (a) and (b) reset, see the chapters on the clock pulse generator (CPG) and watchdog timer (WDT), respectively.

2.3 Interrupt

Table 2.3 Interrupt Signal

Interrupt Signal	Pulse/Level	Active Level	Description
l2_err_int	Level	High	L2 Cache Bus error and ECC error

2.4 Low Power Consumption Mode

2.4.1 AX45MP Sleep Mode

AX45MP Sleep Mode of this LSI is a low power consumption mode obtained by having a core execute the WFI instruction. For details on the WFI instructions, see the AndesCore™ AX45MP-1C Processor Reference Manual.

2.5 Note

2.5.1 L2C Control Register

The following fields of L2C control register (offset: 0x0008) should not be set to 0.

- TRAMOCTL [9:8]
- DRAMOCTL [12:11].

For more information of L2 control register, refer to the AndesCore™ AX45MP-1C Processor Reference Manual.

4. Boot Mode

4.1 Overview

This LSI has six boot modes.

Boot mode 0: Booting from eSD*¹

Boot mode 1: Booting from 1.8-V eMMC*²

Boot mode 2: Booting from 3.3-V eMMC*²

Boot mode 3: Booting from the 1.8-V Single or Quad serial flash memory connected to the SPI multi I/O bus space

Boot mode 4: Booting from the 3.3-V Single or Quad serial flash memory connected to the SPI multi I/O bus space

Boot mode 5: Booting from the program downloaded through the serial communications with FIFO (SCIF)

Note 1. Embedded SD (eSD) defined in the SD Specification Part 1 eSD Addendum (Version 2.10)

Note 2. eMMC supporting the boot operation mode prescribed in JEDEC STANDARD JESD84 A44 (MMCA 4.4)

Once this LSI is released from the system reset state, the clock pulse generator (CPG) executes a specified sequence, and then AX45MP is started first to boot from the device selected according to the settings through the MD_BOOT2 to MD_BOOT0 pins. The values of the MD_BOOT2 to MD_BOOT0 pins are read once the LSI is released from the system reset state.

The CPG_PL1_DDIV register must be set when the user program starts.

Table 4.1 Selection of Boot Mode

MD_BOOT2 to MD_BOOT0			Boot Mode	Interface Module	Connected Device	Reference Section
0	0	0	Boot mode 0	SDHI0	eSD (3.3 V at startup)	4.2.1
0	0	1	Boot mode 1	SDHI0	1.8-V eMMC	4.2.2
0	1	0	Boot mode 2	SDHI0	3.3-V eMMC	4.2.3
0	1	1	Boot mode 3	SPIBSC	1.8-V Single or Quad serial flash memory	4.2.4
1	0	0	Boot mode 4	SPIBSC	3.3-V Single or Quad serial flash memory	4.2.5
1	0	1	Boot mode 5	SCIF0	Downloading through SCIF	4.2.6
1	1	0	Reserved	—	Reserved	—
1	1	1	Reserved	—	Reserved	—

4.2 Operation

4.2.1 Boot Mode 0 (eSD)

Table 4.2 shows the interface signals used for connection with the external device in boot mode 0 (eSD). This LSI supports the embedded SD (eSD) defined in the SD Specification Part 1 eSD Addendum (Version 2.10).

Table 4.2 External Interface Signals Used in Boot Mode 0

Interface Module	Pin Name	I/O	Function	Pin Type
SDHI/eMMC (SDHI0)	SD0_CLK	Output	SD clock	Dedicated pins
	SD0_CMD	Input/output	SD command or response	
	SD0_DATA0	Input/output	SD data 0	
	SD0_DATA1	Input/output	SD data 1	
	SD0_DATA2	Input/output	SD data 2	
	SD0_DATA3	Input/output	SD data 3	
	SD0_CD* ¹	Input	SD card detection	Multiplexed pins
	SD0_WP* ¹	Input	SD write protection	

Note 1. This terminal is not used at boot time.

4.2.1.1 External Connections

Figure 4.1 shows the connections with the eSD device.

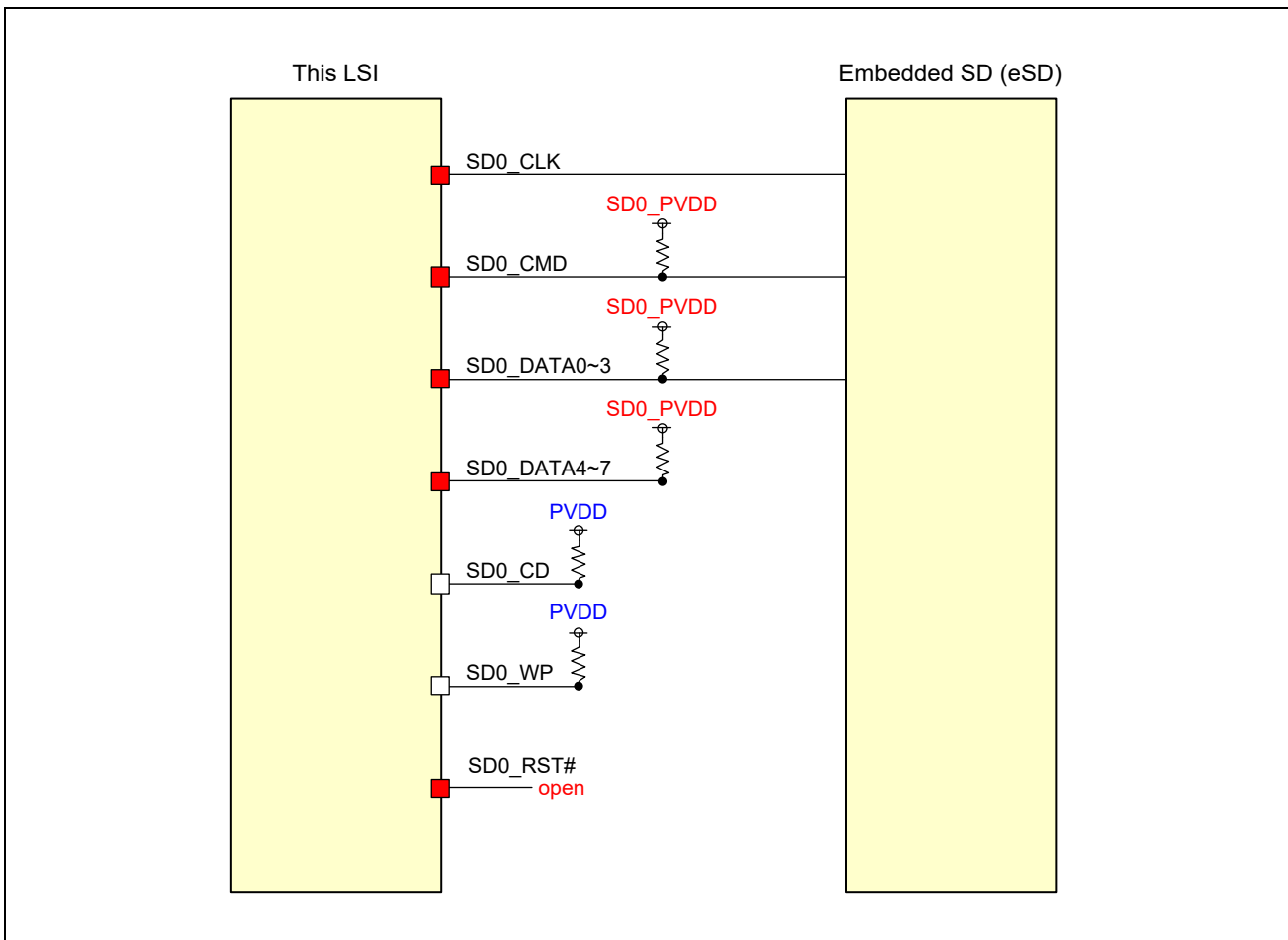

Figure 4.1 Connections in Boot Mode 0

4.2.1.2 Overview of Operation

This mode is used to boot this LSI from the user program stored in the eSD device. The operating voltage is set to 3.3 V and the width of the data bus connected to the eSD device is fixed to four bits in this mode. SDHI0 used as the interface controller in this mode is placed in the module standby mode at the startup of the LSI. Once SDHI0 is released from the module standby mode, the boot program in this LSI sets up the CPG so that the frequency of the external output clock becomes 16.6 MHz, initializes SDHI0, and then begins the booting process with the I/O buffers set to the maximum driving ability.

4.2.1.3 Operation of Booting from eSD

In boot mode 0 (booting from eSD), this LSI is booted from the loader program in the eSD device connected to channel 0 of the SD host interface (SDHI) as follows.

The boot program executes the following processing to access the eSD device.

1. Setting up the necessary peripheral modules (SDHI channel 0 and GPIO)
2. Mounting the eSD device
3. Issuing a read command to the eSD device through the SDHI to obtain the size of the loader program data from sector 1 of the selected partition

After obtaining the size of the loader program data, the SDHI issues a read command to the eSD device to transfer the loader program from sector 8 of the selected partition to the addresses H'0_0001_2000 to H'0_0002_EFFF of the on-chip RAM for the obtained data size.

Then, execution branches to the start address (H'0_0001_2000) of the loader program transferred to the on-chip RAM to execute the loader program that was stored in the eSD device.

If the boot program has failed to read data, it reads data from a reserved area. If reading has failed for all reserved areas, the boot program enters fail-safe mode (SCIF downloading mode). If the fail-safe processing has failed, execution enters an infinite loop in the on-chip ROM and the boot processing is terminated.

4.2.1.4 Allocation of the Loader Programs in the eSD Device

(1) Allocation in eSD V2.0 (Single Partition)

Figure 4.2 shows the allocation of the loader program size blocks and loader programs in the eSD device conforming to the eSD V2.0 standard. To prevent read-disturb errors, up to seven loader program size blocks and loader programs can be multiplexed and written to the eSD device.

The loader program size blocks are allocated to sectors 1 to 7. In a loader program size block, the loader program size is stored in the first four bytes and the signature H'AA55 is stored in the last two bytes. **Figure 4.3** shows the structure of the loader program size data. Be sure to store the loader program size in 4-byte little endian.

The following describes the operation of transferring the loader program.

- (1) The loader program size block is transferred from sector 1 in physical partition #0 of the eSD device to the on-chip RAM.
If a communication error occurs during data transfer, read access is retried up to three times per area. If the retry processing is repeated three times during the transfer of the loader program size block in a single area, another loader program size block is transferred from the next multiplexed area.
- (2) The signature in the transferred loader program size block is checked. When the signature matches the expected value (H'AA55), the size of the loader program data is obtained from the loader program size block and the processing for transferring the loader program is executed.
If the signature does not match the expected value, another loader program size block is transferred from the next multiplexed area.
- (3) The transfer of the loader program begins from sector 8 in physical partition #0 of the eSD device. The loader program is transferred to the on-chip RAM for the obtained loader program size.
If a communication error occurs during data transfer, read access is retried up to three times per area. If the retry processing is repeated three times during the loader program transfer in a single area, another loader program is transferred from the next multiplexed area.

NOTE

Even when the loader size block is transferred from a multiplexed (reserved) area, the transfer of the loader program always begins from the area for loader program #0.

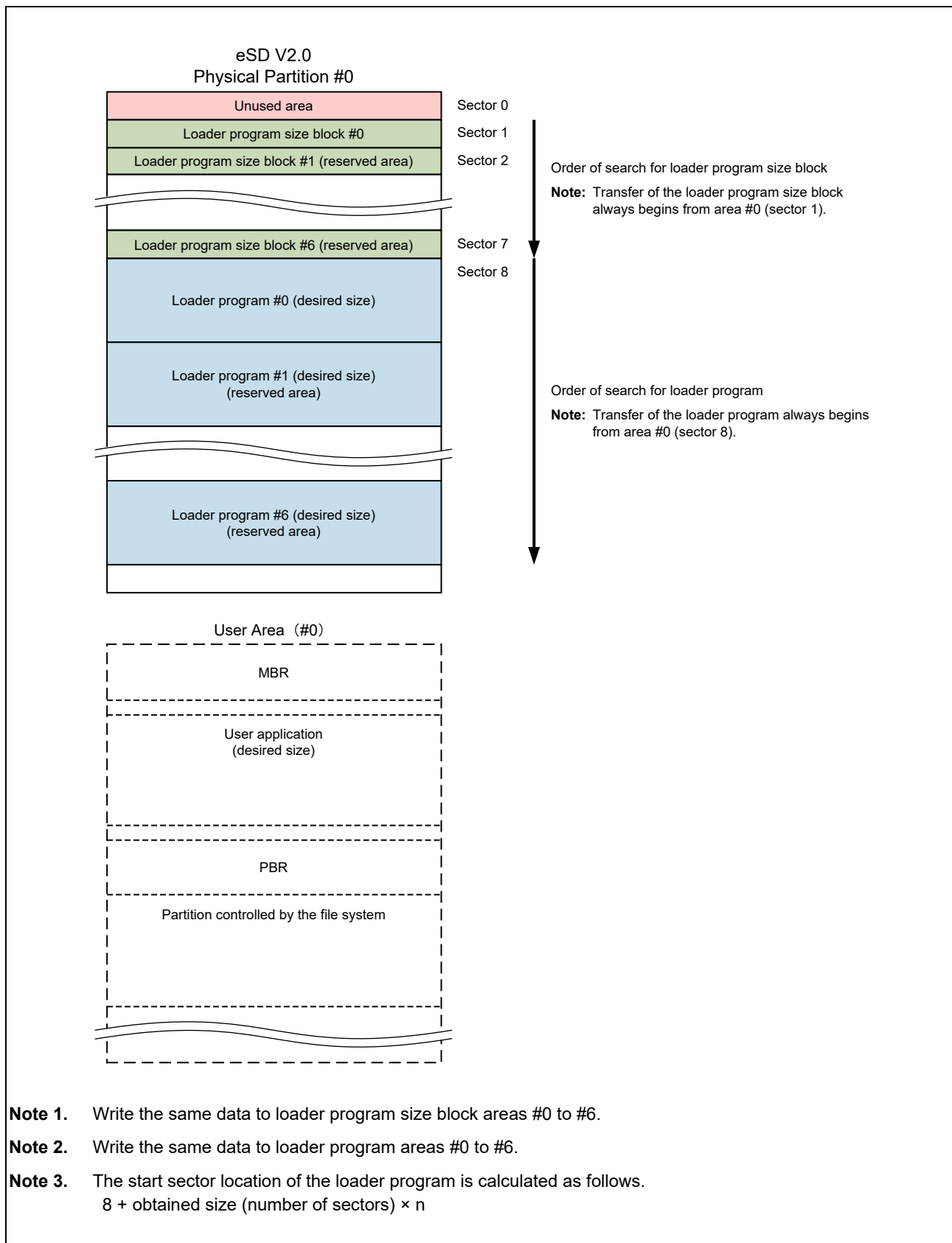

Figure 4.2 Allocation of Loader Programs in the eSD Device Conforming to the eSD V2.0 Standard

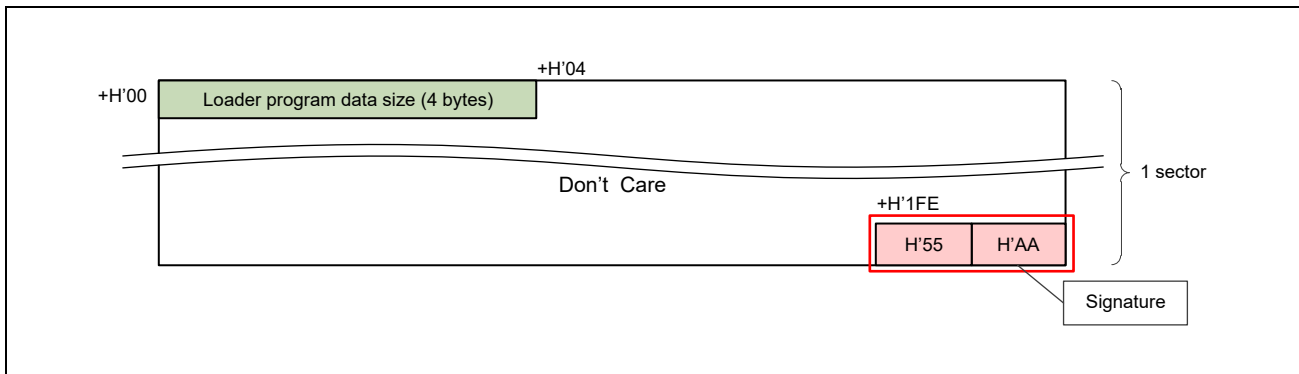

Figure 4.3 Structure of the Loader Program Size Block

NOTE

Store the loader program data size in 4-byte little endian.

(2) Allocation in eSD V2.1 (Multi Partitions)

Figure 4.4 shows the allocation of the loader program size blocks and loader programs in the eSD device conforming to the eSD V2.1 standard. To prevent read-disturb errors, up to seven loader program size blocks and loader programs can be multiplexed and written to the eSD device

The specifications and allocation of loader program size blocks are the same as those in eSD V2.0. For the structure of the loader program size block, see **Figure 4.3**.

The following describes the operation of transferring the loader program.

- (1) The loader program size block is transferred from sector 1 in physical partition #1 of the eSD device to the on-chip RAM.
If a communication error occurs during data transfer, read access is retried up to three times per area. If the retry processing is repeated three times during the transfer of the loader program size block in a single area, another loader program size block is transferred from the next multiplexed area.
- (2) The signature in the transferred loader program size block is checked. When the signature matches the expected value (H'AA55), the size of the loader program data is obtained from the loader program size block and the processing for transferring the loader program is executed. If the signature does not match the expected value, another loader program size block is transferred from the next multiplexed area.
- (3) The transfer of the loader program begins from sector 8 in physical partition #1 of the eSD device. The loader program is transferred to the on-chip RAM for the obtained loader program size.
If a communication error occurs during data transfer, read access is retried up to three times per area. If the retry processing is repeated three times during the loader program transfer in a single area, another loader program is transferred from the next multiplexed area.

NOTE

Even when the loader size block is transferred from a multiplexed (reserved) area, the transfer of the loader program always begins from the area for loader program #0.

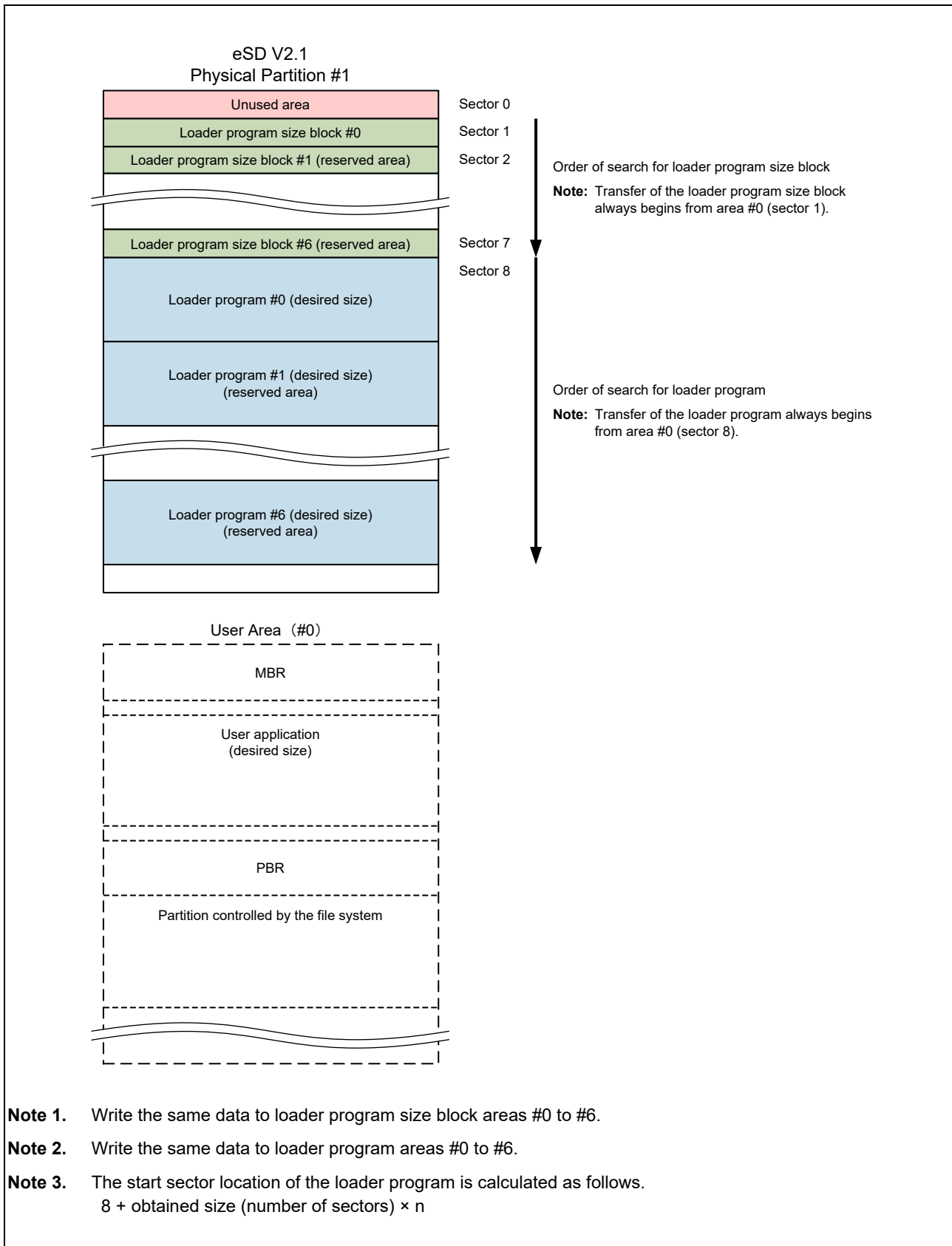

Figure 4.4 Allocation of Loader Programs in the eSD Device Conforming to the eSD V2.1 Standard

(3) How to Distinguish between eSD V2.0 (Single Partition) and V2.1 (Multi Partitions)

This boot program first assumes that an eSD device supporting multi partitions is connected and begins loader program transfer from physical partition #1. If an error regarding a command for multi partitions shown in the following table occurs, the boot program assumes that an eSD device with a single partition is connected and transfers the loader program from physical partition #0.

Table 4.3 Errors Regarding Commands for Multi Partitions

No.	Issued Command	Command Function	Error	Remarks
1	CMD43 (SELECT_PARTITION)	Selects physical partition #1.	Multi partitions are not supported.	
2	CMD45 (QUERY_PARTITION)	Obtains the physical partition ID.	The specified partition does not exist.	

4.2.1.5 Note

The shared bus and 8-bit SD bus of the embedded SDIO cannot be used in this mode.

4.2.2 Boot Mode 1 (1.8-V eMMC)

Table 4.4 shows the interface signals used for connection with the external device in boot mode 1 (eMMC). This LSI supports the eMMC that operates in the boot operation mode prescribed in JEDEC STANDARD JESD84 A44 (MMCA 4.4).

Table 4.4 External Interface Signals Used in Boot Mode 1

Interface Module	Pin Name	I/O	Function	Pin Type
SDHI/eMMC (SDHI0)	SD0_CLK	Output	eMMC clock	Dedicated pins (1.8 V)
	SD0_CMD	Input/output	eMMC command or response	
	SD0_DATA0	Input/output	eMMC data 0	
	SD0_DATA1	Input/output	eMMC data 1	
	SD0_DATA2	Input/output	eMMC data 2	
	SD0_DATA3	Input/output	eMMC data 3	
	SD0_DATA4	Input/output	eMMC data 4	
	SD0_DATA5	Input/output	eMMC data 5	
	SD0_DATA6	Input/output	eMMC data 6	
	SD0_DATA7	Input/output	eMMC data 7	
	SD0_CD* ¹	Input	SD card detection	Multiplexed pins
	SD0_WP* ¹	Input	SD write protection	
	SD0_RST#	Output	eMMC reset	Dedicated pins (1.8 V)

Note 1. This terminal is not used at boot time.

4.2.2.1 External Connections

Figure 4.5 shows the connections with the eMMC device. The boot program in this LSI does not monitor the state of the SD0_CD and SD0_WP pins.

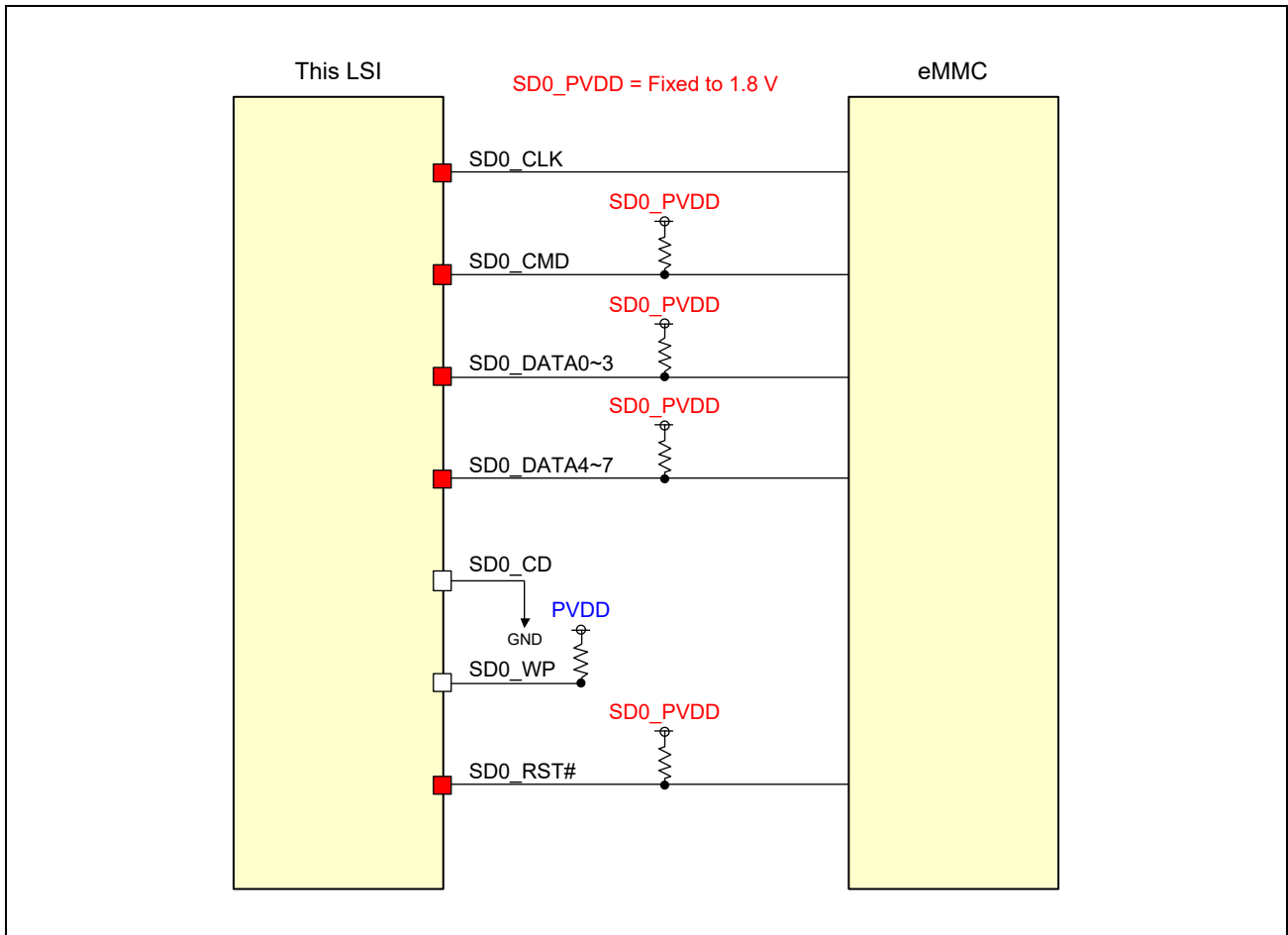

Figure 4.5 Connections in Boot Mode 1

4.2.2.2 Overview of Operation

This mode is used to boot this LSI from the user program stored in the eMMC device. The operating voltage is set to 1.8 V and the width of the data bus connected to the eMMC device is fixed to eight bits in this mode. SDHI0 used as the interface controller in this mode is placed in the module standby mode at the startup of the LSI. Once SDHI0 is released from the module standby mode, the boot program in this LSI sets up the CPG so that the frequency of the external output clock becomes 16.6 MHz, initializes SDHI0, and then begins the booting process.

4.2.2.3 Operation of Booting from 1.8-V eMMC

In boot mode 1 (booting from 1.8-V eMMC), this LSI is booted from the loader program in the 1.8-V eMMC device connected to channel 0 of the SD host interface (SDHI) as follows.

The boot program executes the following processing to access the eMMC device.

1. Setting up the necessary peripheral modules (SDHI channel 0 and OSTM channel 0)
2. Starting the alternative boot operation mode of the eMMC device
Read access begins from sector 0 of the partition selected by the [179] field (PARTITION_CONFIG) of the extended CSD (EXT_CSD) register in the eMMC device. For details, refer to **Section 4.2.2.5** and **Section 4.2.2.5(1)**.
3. Dummy reading from sector 0 and obtaining the size of the loader program data from sector 1

After the size of the loader program data is obtained, the loader program is transferred from sector 2 to the addresses H'0_0001_2000 to H'0_0002_EFFF of the on-chip RAM for the obtained data size.

Then, execution branches to the start address (H'0_0001_2000) of the loader program transferred to the on-chip RAM to execute the loader program that was stored in the eMMC device.

If the boot program has failed to read the loader program, it enters fail-safe mode (SCIF downloading mode). If the fail-safe processing has failed, execution enters an infinite loop in the on-chip ROM and the boot processing is terminated.

Note that the data bus width is set to eight bits for booting from the eMMC device.

4.2.2.4 Allocation of the Loader Program in the eMMC Device

Figure 4.6 shows the allocation of the loader program in the eMMC device conforming to the MMCA 4.4 standard.

In the loader program size block, the loader program size is stored in the first four bytes and the signature H'AA55 is stored in the last two bytes. **Figure 4.7** shows the structure of the loader program size data. Be sure to store the loader program size in 4-byte little endian.

The transfer of the loader program begins from the first address (sector 0) of the boot partition. A dummy read from sector 0 is done, and then the size of the loader program data is obtained from the data read from sector 1. The loader program is transferred from sector 2 to the addresses H'0_0001_2000 to H'0_0002_EFFF of the on-chip RAM for the obtained loader program size.

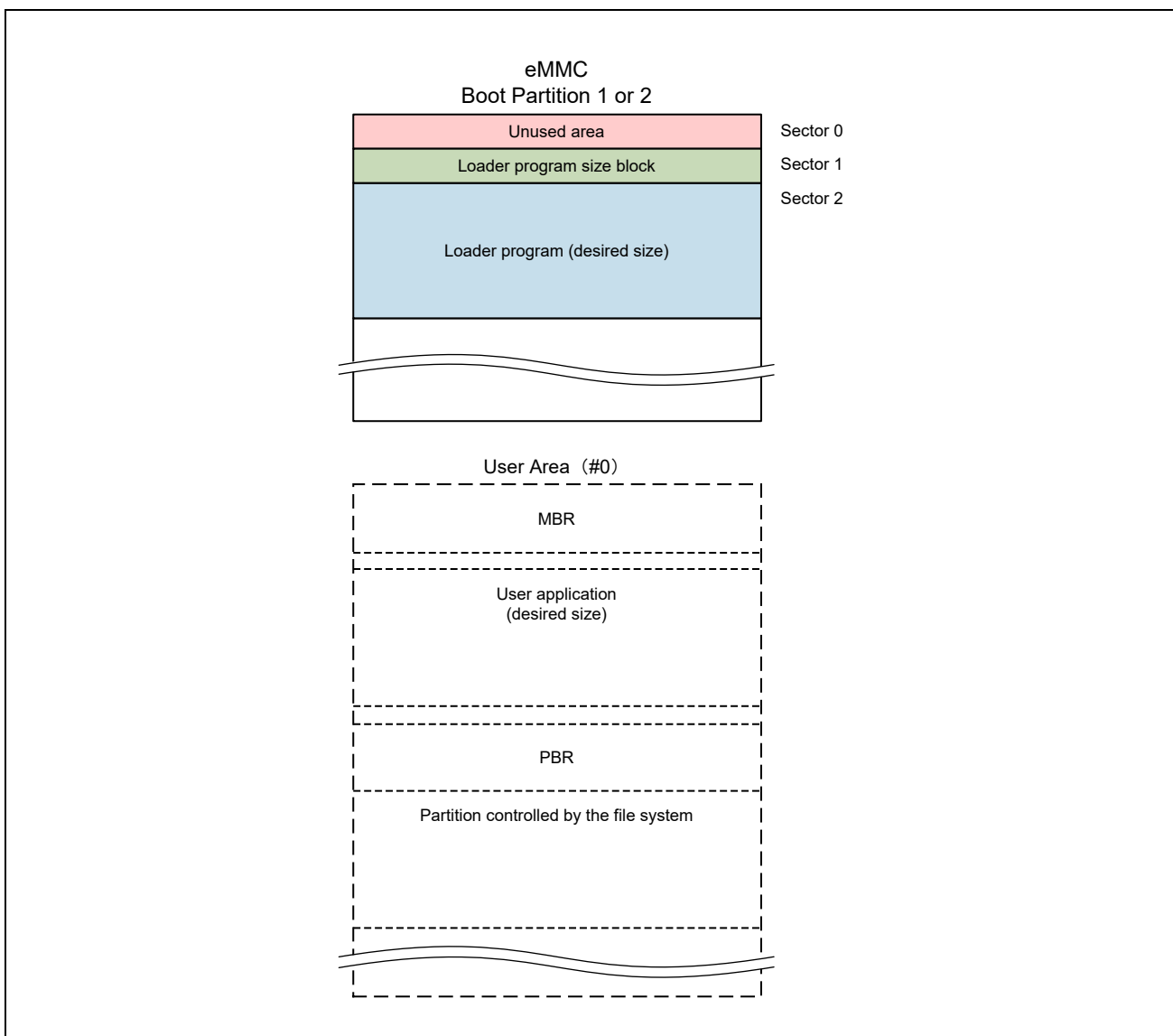

Figure 4.6 Allocation of Loader Program in the eMMC Device

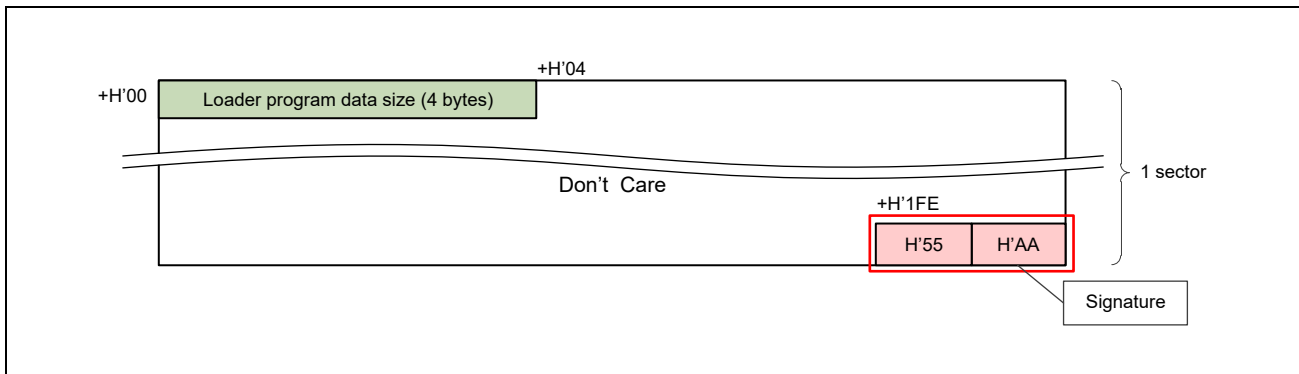

Figure 4.7 Structure of the Loader Program Size Block

In the eMMC device, the loader program is read from the partition specified by the `BOOT_PARTITION_ENABLE` bits in the `PARTITION_CONFIG (ECSD[179])` field of the extended CSD register. Write the loader program to the partition selected by this register. **Table 4.5** shows the specifications of the extended CSD register.

Table 4.5 Specifications of the Extended CSD Register

No.	Field Name	Bit Name	Setting	Remarks
1	<code>PARTITION_CONFIG (ECSD[179])</code>	<code>BOOT_PARTITION_ENABLE</code> bits [5:3]	H'0: Device not boot enabled (default) H'1: Boot partition 1 enabled for boot H'2: Boot partition 2 enabled for boot H'7: User area enabled for boot	

Allocate partitions as follows.

- Store the loader program in boot partition 1.
- Store the application program in boot partition 2.
- Allocate the user area to a partition controlled by the file system.

4.2.2.5 Alternative Boot Operation

Figure 4.8 shows the alternative boot operation to read the loader program. This boot program sets up the registers in SDHI channel 0 so that the SDHI operates with an 8-bit bus width when booting from the eMMC device. On the eMMC device side, the data bus width in the alternative boot operation is determined by the setting of the `BOOT_BUS_WIDTH[177]` field in the extended CSD register. To boot up from the eMMC device correctly, set up the extended CSD register in the eMMC device as shown in **Table 4.6** when writing a program to the eMMC device.

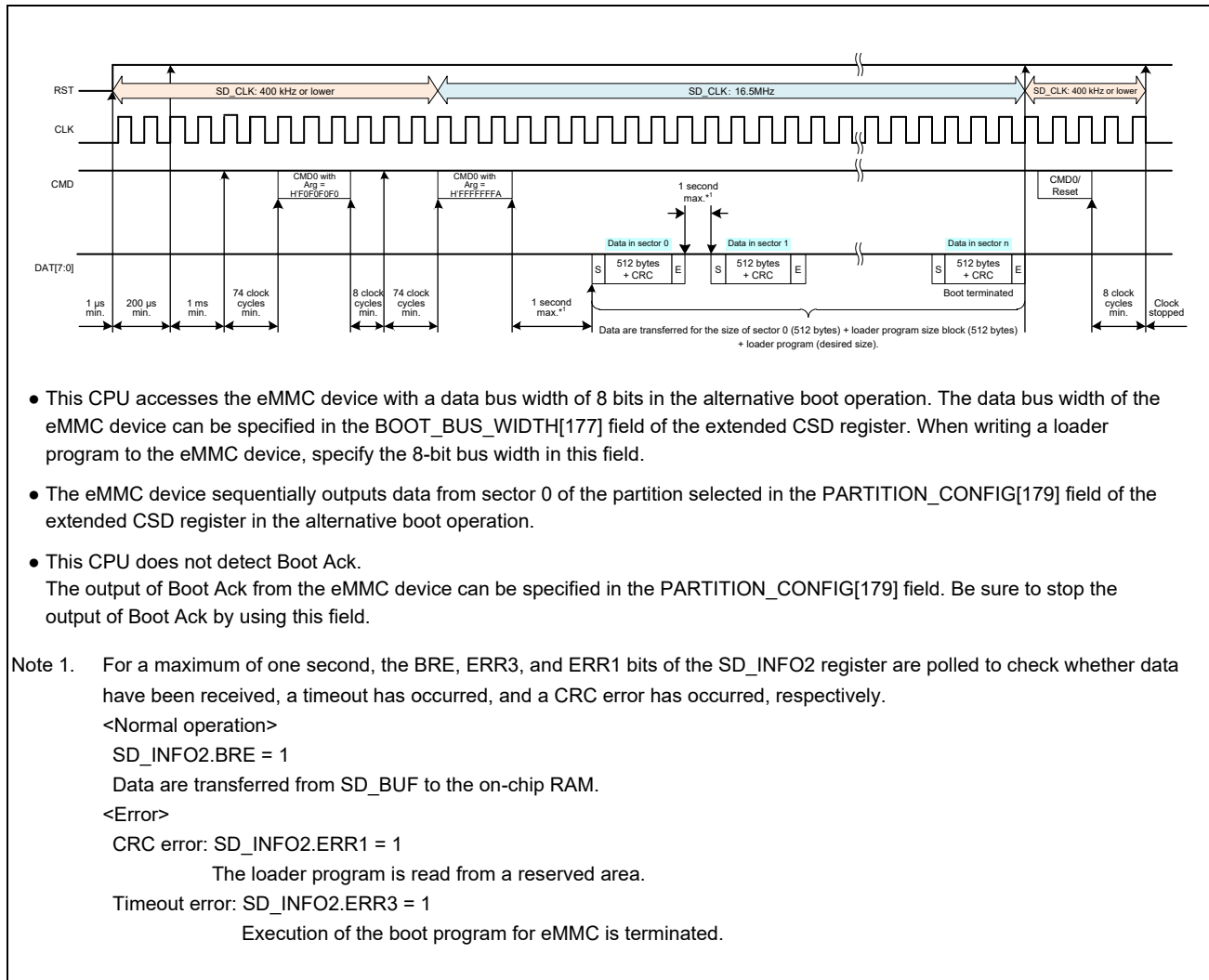

Figure 4.8 Alternative Boot Operation to Read the Loader Program

Table 4.6 Setting of the Data Bus Width in Alternative Boot Operation

Field in Extended CSD Register of eMMC Device	Setting
<code>BOOT_BUS_WIDTH [177]</code>	Bits 1 and 0: <code>BOOT_BUS_WIDTH = 10b</code> (The bus width is set to 8 bits in alternative boot operation.)

(1) Partitions

An eMMC device has multiple partitions (**Figure 4.9**). The partition used for booting can be specified in the PARTITION_CONFIG[179] field of the extended CSD (EXT_CSD) register. To boot up correctly, specify the boot partition in the extended CSD (EXT_CSD) register of the eMMC device as shown in **Table 4.7** when writing a program to the eMMC device.

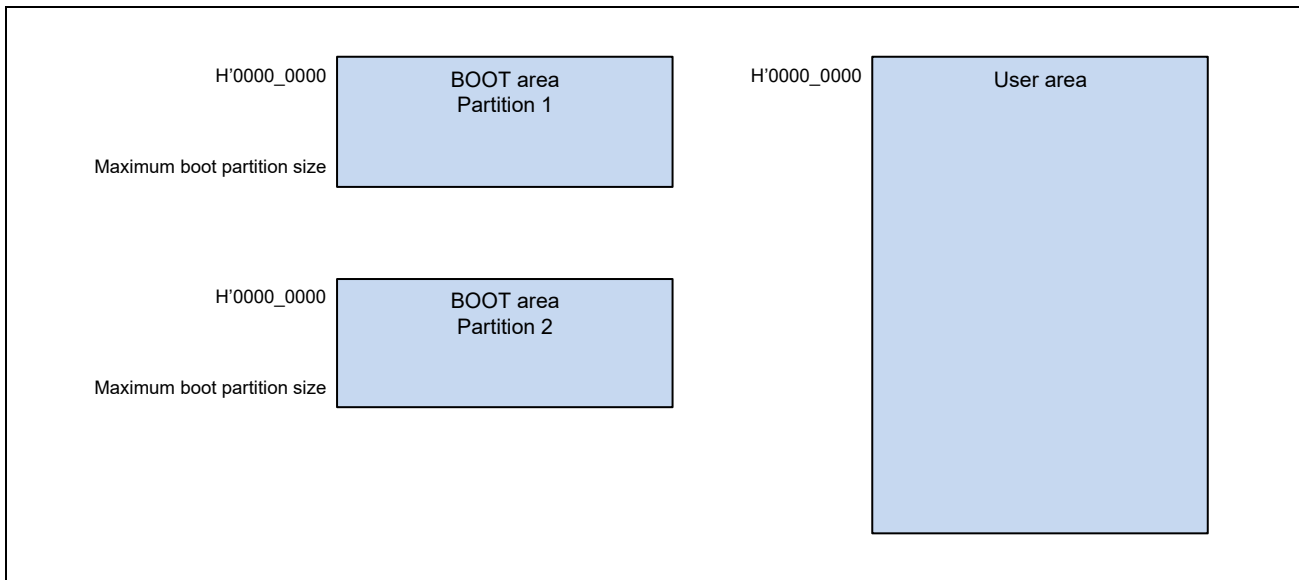

Figure 4.9 Partitions in the eMMC Device

Table 4.7 Boot Partition Setting in the Alternative Boot Operation

Field in Extended CSD Register of eMMC Device	Setting
PARTITION_CONFIG [179]	<ul style="list-style-type: none"> Set bit 6 (BOOT_ACK) to 0b (the eMMC device does not output a boot acknowledge in the alternative boot operation). Specify the boot partition in bits 5 to 3 (BOOT_PARTITION_ENABLE). <ul style="list-style-type: none"> 000b: Booting is disabled. 001b: Booting from sector 0 in boot partition 1 in the boot operation. 010b: Booting from sector 0 in boot partition 2 in the boot operation. 011b to 110b: Reserved 111b: Booting from sector 0 in the user area in the boot operation.

4.2.2.6 Notes

- This mode does not support booting from an MMC card.
- The width of the data bus is fixed to eight bits; 1-bit or 4-bit data bus cannot be used in this mode.

4.2.3 Boot Mode 2 (3.3-V eMMC)

Table 4.8 shows the interface signals used for connection with the external device in boot mode 2 (eMMC). This LSI supports the eMMC that operates in the boot operation mode prescribed in JEDEC STANDARD JESD84 A44 (MMCA 4.4).

Table 4.8 External Interface Signals Used in Boot Mode 2

Interface Module	Pin Name	I/O	Function	Pin Type
SDHI/eMMC (SDHI0)	SD0_CLK	Output	eMMC clock	Dedicated pins (3.3 V)
	SD0_CMD	Input/output	eMMC command or response	
	SD0_DATA0	Input/output	eMMC data 0	
	SD0_DATA1	Input/output	eMMC data 1	
	SD0_DATA2	Input/output	eMMC data 2	
	SD0_DATA3	Input/output	eMMC data 3	
	SD0_DATA4	Input/output	eMMC data 4	
	SD0_DATA5	Input/output	eMMC data 5	
	SD0_DATA6	Input/output	eMMC data 6	
	SD0_DATA7	Input/output	eMMC data 7	
	SD0_CD* ¹	Input	SD card detection	Multiplexed pins
	SD0_WP* ¹	Input	SD write protect	
	SD0_RST#	Output	eMMC reset	Dedicated pins (3.3 V)

Note 1. This terminal is not used at boot time.

4.2.3.1 External Connections

Figure 4.10 shows the connections with the eMMC device. The boot program in this LSI does not monitor the state of the SD0_CD and SD0_WP pins.

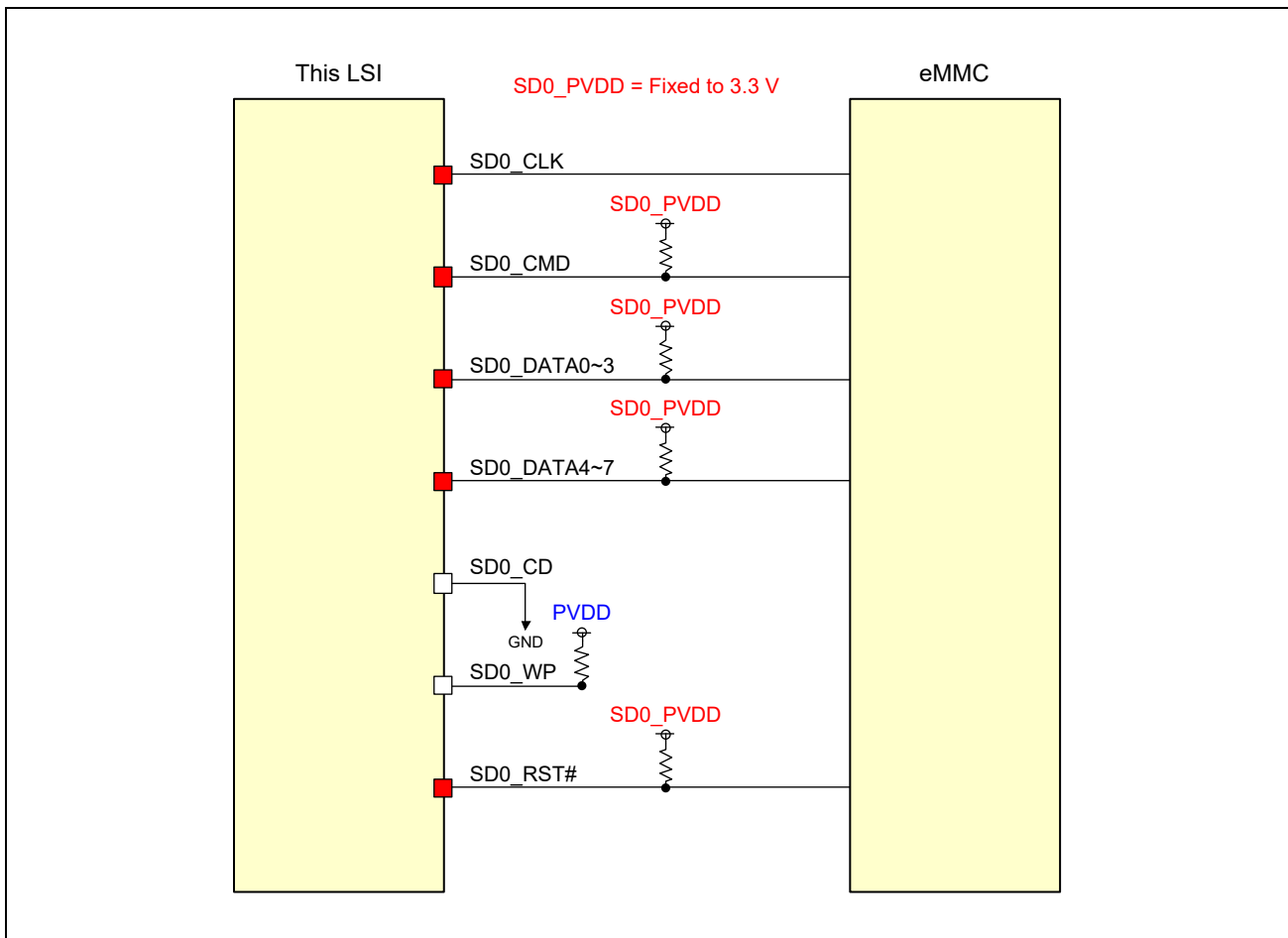

Figure 4.10 Connections in Boot Mode 2

4.2.3.2 Overview of Operation

This mode is used to boot this LSI from the user program stored in the eMMC device in the same way as boot mode 1. This mode only differs from boot mode 1 in that the external device operates at 3.3 V. The operating voltage is set to 3.3 V in this mode.

4.2.3.3 Operation of Booting from 3.3-V eMMC

Boot mode 2 (booting from 3.3-V eMMC) only differs from boot mode 1 (booting from 1.8-V eMMC) in the setting of supplied voltage as shown in **Table 4.9**.

Table 4.9 Resources Used by the Boot Program for 3.3-V eMMC (Difference from 1.8-V eMMC)

No.	Register Name	Address	Initial Value	Value after Booting	Remarks
1	GPIO_SD_CH0	H'0_1103_3000	H'0000_0000	H'0000_0000	SD0_PVDD: 0 = 3.3 V In boot mode 1 or 2, this is automatically set by hardware. The user does not need to set this register.

4.2.3.4 Notes

- This mode does not support booting from an MMC card.
- The width of the data bus is fixed to eight bits; 1-bit or 4-bit data bus cannot be used in this mode.

4.2.4 Boot Mode 3 (1.8-V Single or Quad Serial Flash Memory)

Table 4.10 shows the interface signals used for connection with the external device in boot mode 3 (1.8-V serial flash memory).

Table 4.10 External Interface Signals Used in Boot Mode 3

Interface Module	Pin Name	I/O	Function	Pin Type
QSPI0	QSPI0_SPCLK	Input/output	QSPI clock	Dedicated pins (1.8 V)
	QSPI0_IO0	Input/output	QSPI data 0	
	QSPI0_IO1	Input/output	QSPI data 1	
	QSPI0_IO2	Input/output	QSPI data 2	
	QSPI0_IO3	Input/output	QSPI data 3	
	QSPI0_SSL	Output	Slave select	
	QSPI_RESET#	Output	QSPI reset	
	QSPI_WP#	Output	QSPI write protect	

Note: Only interface 0 is used and the pins shaded in gray are not controlled in this mode. To use the shaded pins after booting, control them by the user program.

4.2.4.1 External Connections

Figure 4.11 and Figure 4.12 show the connections with the Single SPI memory and Quad SPI memory, respectively.

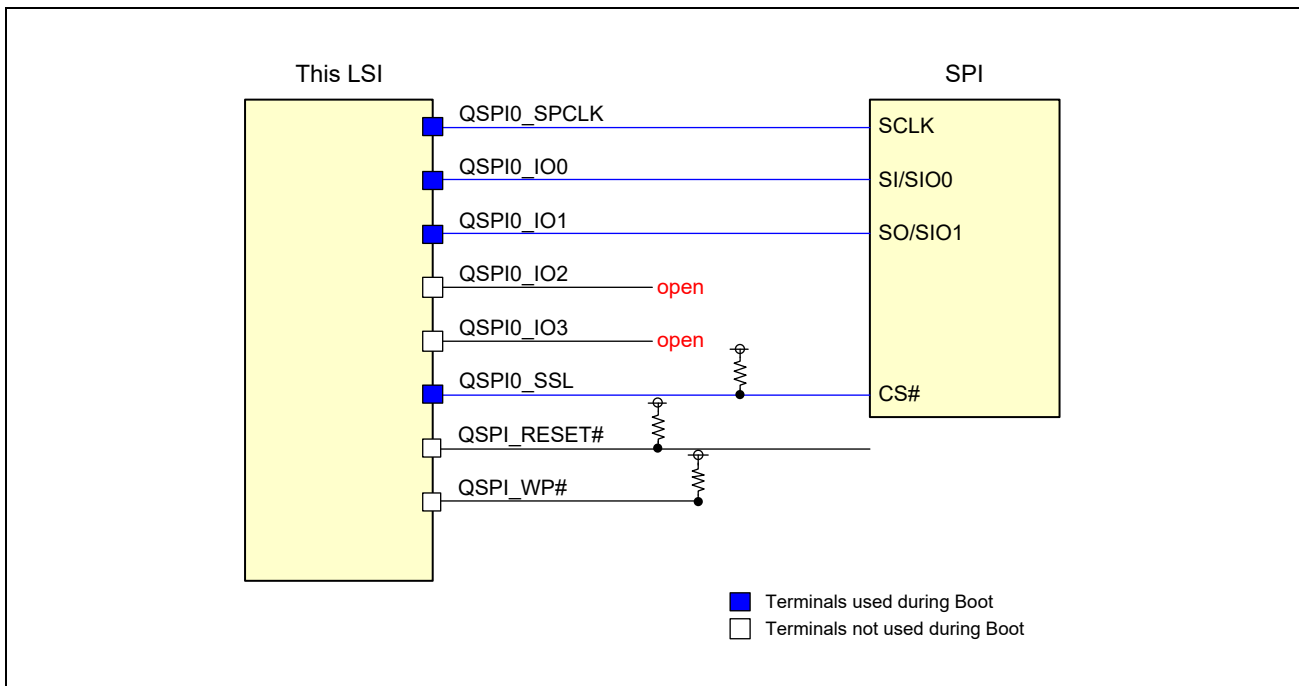

Figure 4.11 Connections with Single SPI Memory in Boot Mode 3

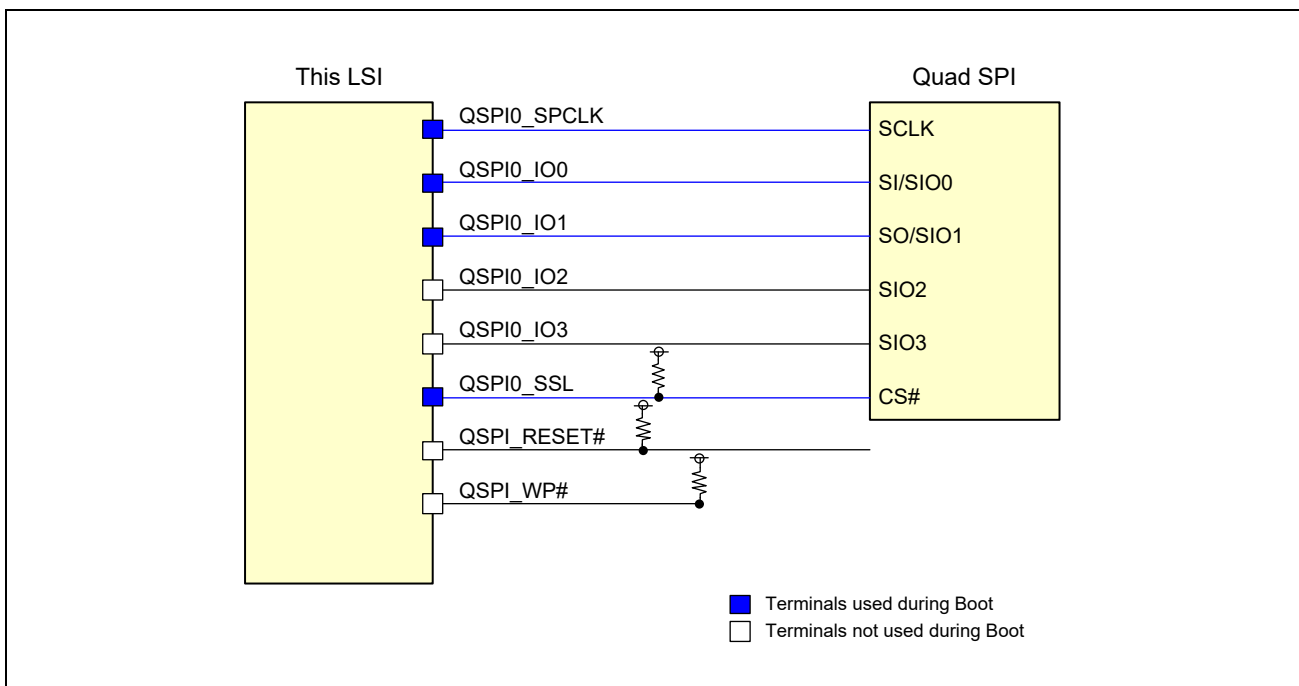

Figure 4.12 Connections with Quad SPI Memory in Boot Mode 3

4.2.4.2 Overview of Operation

This mode is used to boot this LSI from the user program stored in the Single or Quad flash memory device.

The serial flash memory mounted in advance on the board is used in this mode. The target device operates at 1.8 V and the I/O power of this LSI is also fixed to 1.8 V in this mode. The clock frequency at the startup is set to 16.6 MHz. The LSI is booted up through an SPI handshake with the Single or Quad flash memory device.

Upon detecting boot mode 3 according to the value read from the SYSC, the boot program makes the necessary settings of the SPI multi I/O bus controller to access memory. The boot program handles the following steps to control the booting process.

1. The CPG is set up to supply clocks, and the SPI multi I/O bus controller receives the operating clock and is released from the reset state.
2. The necessary information to control the I/O buffers is read from the registers in the SYSC. The given information is copied from the OTPC to the SYSC registers in advance.
3. The properties such as the driving ability of the I/O buffers of the signals to be used are set up.
4. After the above setup, the SPI multi I/O bus controller performs a handshake process with the target memory device.
5. When a Quad SPI handshake is required, the user program should control the process.

4.2.4.3 Operation of Booting from 1.8-V Serial Flash Memory

In boot mode 3 (booting from the serial flash memory), this LSI is booted from the loader program in the 1.8-V serial flash memory connected to the SPI multi I/O bus controller (SPIBSC).

The boot program executes the following processing to access the SPI multi I/O bus space.

1. Releasing the SPIBSC from module standby mode
2. Setting up the registers in the necessary peripheral modules (SPIBSC and GPIO)
3. Obtaining the size of the loader program data stored in the area starting from "the start address of the SPI multi I/O bus space (H'0_2000_0000) + offset" through the SPIBSC

After obtaining the size of the loader program data, the SPIBSC transfers the loader program stored in the area starting from "the start address of the SPI multi I/O bus space (H'0_2000_0000) + offset" to the addresses H'0_0001_2000 to H'0_0002_EFFF of the on-chip RAM for the obtained data size.

Then, execution branches to the start address (H'0_0001_2000) of the loader program transferred to the on-chip RAM to execute the loader program that was stored in the serial flash memory.

If the boot program has failed to read data, the boot program enters fail-safe mode (SCIF downloading mode). If the fail-safe processing has failed, execution enters an infinite loop in the on-chip ROM and the boot processing is terminated.

4.2.4.4 Allocation of the Loader Program in the Serial Flash Memory

Figure 4.13 shows the allocation of the loader program size block and loader program in the serial flash memory.

In the loader program size block, the loader program size is stored in the first four bytes and the signature H'AA55 is stored in the last two bytes. Figure 4.14 shows the structure of the loader program size data. Be sure to store the loader program size in 4-byte little endian.

The loader program is transferred from the area starting from the address “H'0_2000_0000 + H'0200 (offset)” to the addresses H'0_0001_2000 to H'0_0002_EFFF of the on-chip RAM for the obtained loader program size.

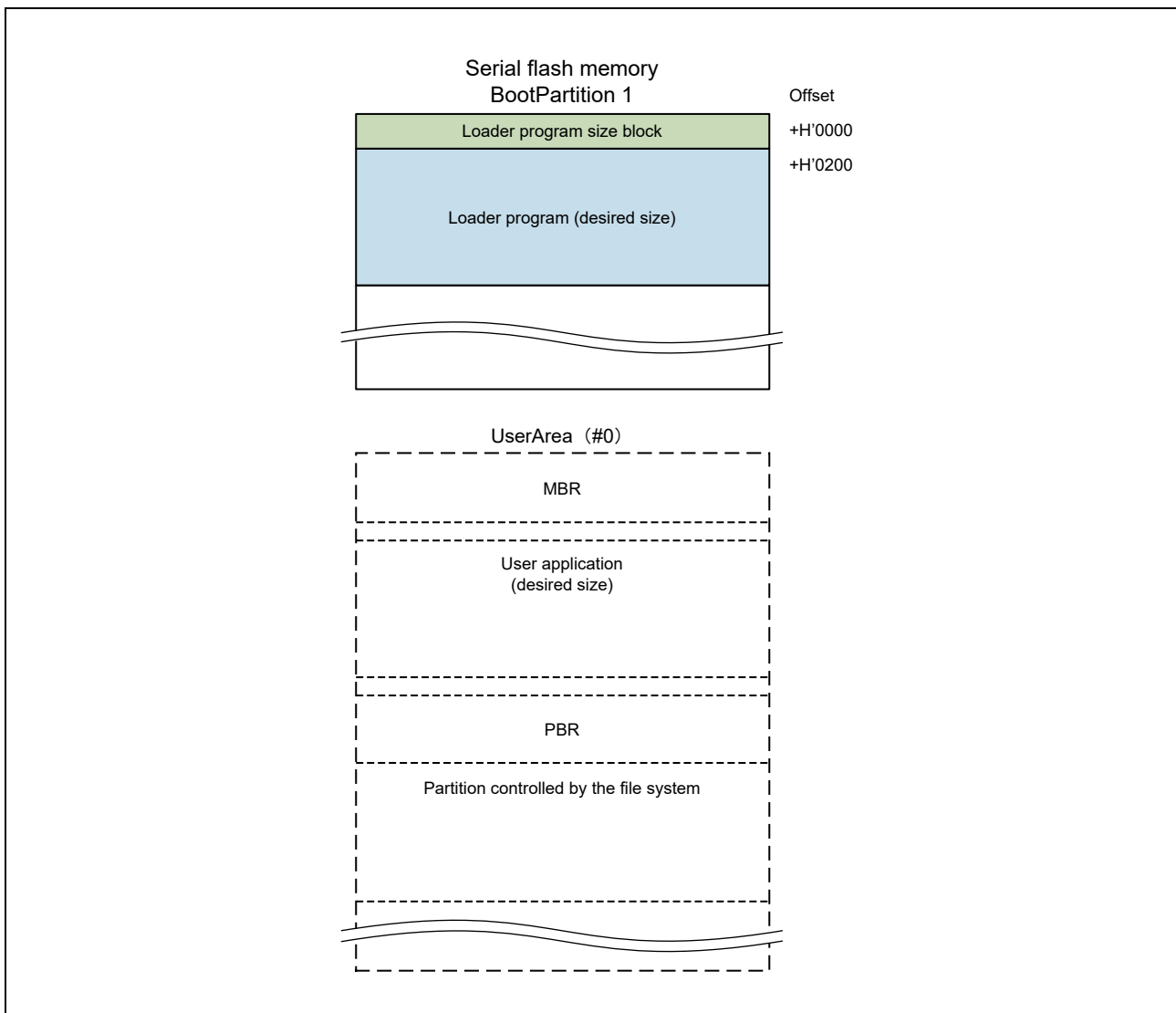

Figure 4.13 Allocation of Loader Program in the Serial Flash Memory Device

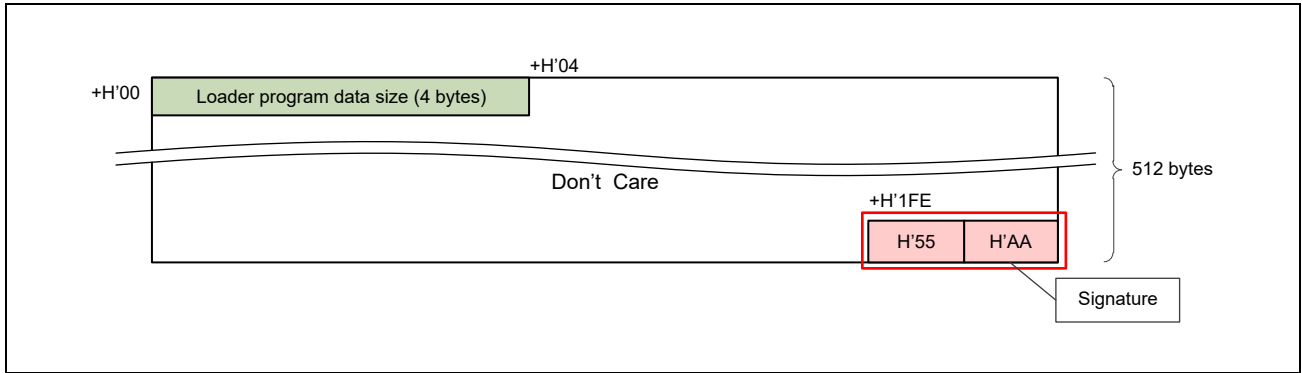

Figure 4.14 Structure of the Loader Program Size Block

4.2.5 Boot Mode 4 (3.3-V Single or Quad Serial Flash Memory)

Table 4.11 shows the interface signals used for connection with the external device in boot mode 4 (3.3-V serial flash memory).

Table 4.11 External Interface Signals Used in Boot Mode 4

Interface Module	Pin Name	I/O	Function	Pin Type
QSPI0	QSPI0_SPCLK	Input/output	QSPI clock	Dedicated pins (3.3 V)
	QSPI0_IO0	Input/output	QSPI data 0	
	QSPI0_IO1	Input/output	QSPI data 1	
	QSPI0_IO2	Input/output	QSPI data 2	
	QSPI0_IO3	Input/output	QSPI data 3	
	QSPI0_SSL	Output	QSPI data 4	
	QSPI_RESET#	Output	QSPI reset	
	QSPI_WP#	Output	QSPI write protect	

Note: Only interface 0 is used and the pins shaded in gray are not controlled in this mode. To use the shaded pins after booting, control them by the user program.

4.2.5.1 External Connections

Figure 4.15 and Figure 4.16 show the connections with the 3.3-V Single SPI memory and 3.3-V Quad SPI memory, respectively.

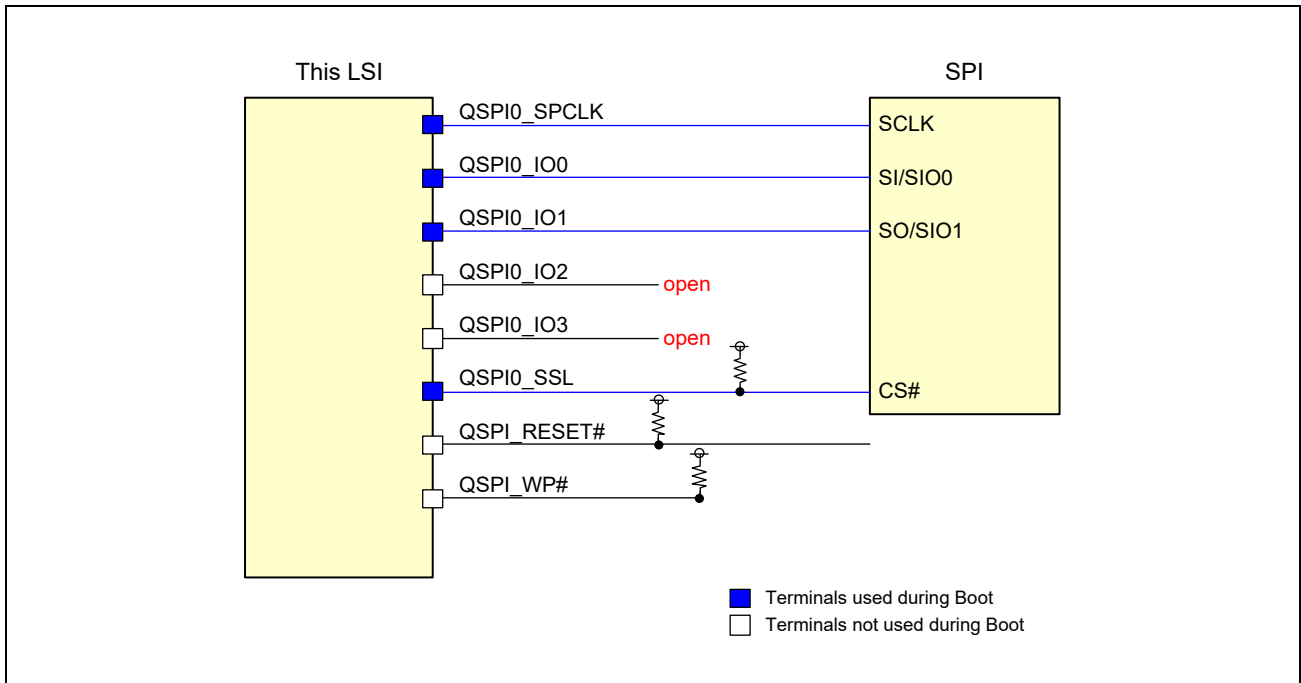

Figure 4.15 Connections with Single SPI Memory in Boot Mode 4

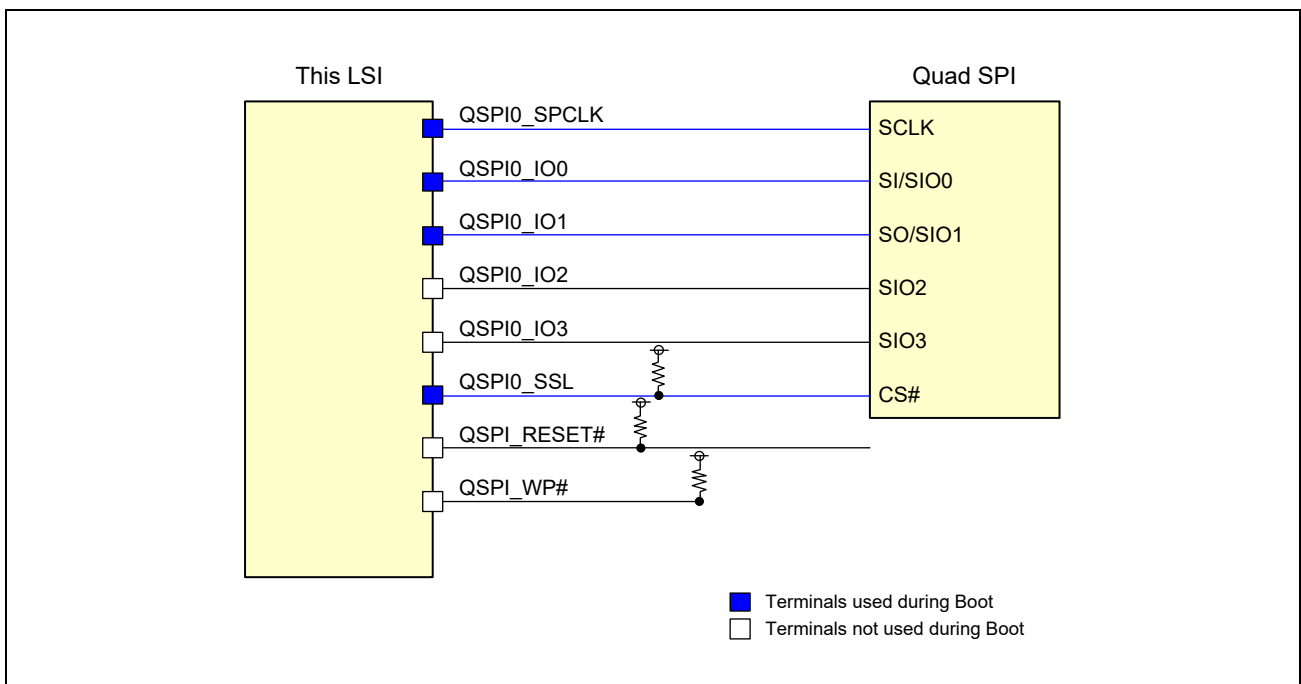

Figure 4.16 Connections with Quad SPI Memory in Boot Mode 4

4.2.5.2 Overview of Operation

This mode is used to boot this LSI from the user program stored in the Single or Quad SPI memory device. The serial flash memory mounted in advance on the board is used in this mode. The target device operates at 3.3 V and the I/O power of this LSI is also fixed to 3.3 V in this mode. The clock frequency at the startup is set to 16.6 MHz.

Upon detecting boot mode 4 according to the value read from the SYSC, the boot program makes the necessary settings of the SPI multi I/O bus controller to access memory. The boot program handles the following steps to control the booting process.

1. The CPG is set up to supply clocks, and the SPI multi I/O bus controller receives the operating clock and is released from the reset state.
2. The necessary information to control the I/O buffers is read from the registers in the SYSC. The information is copied from the OTPC to the SYSC registers in advance.
3. The properties such as the driving ability of the I/O buffers of the signals to be used are set up.
4. After the above setup, the SPI multi I/O bus controller performs a handshake process with the target memory device.
5. When a Quad SPI handshake is required, the user program should control the process.

4.2.5.3 Operation of Booting from 3.3-V Serial Flash Memory

Boot mode 4 (booting from 3.3-V serial flash memory) only differs from boot mode 3 (booting from 1.8-V serial flash memory) in the setting of supplied voltage as shown in **Table 4.12**.

Table 4.12 Resources Used by the Boot Program for 3.3-V Serial Flash Memory (Difference from 1.8-V Serial Flash Memory)

Register Name	Address	Initial Value	Value after Booting	Remarks
GPIO_QSPI	H'0_1101_3008	H'0000_0000	H'0000_0000	QSPI_PVDD: 0 = 3.3 V In boot mode 3 or 4, this is automatically set by hardware. The user does not need to set this register.

4.2.5.4 Note

When interface 0 of the SPI multi I/O bus controller is connected with the SPI or QSPI memory, interface 1 can only be used to connect the same type of memory.

4.2.6 Boot Mode 5 (SCIF Downloading)

Table 4.13 shows the interface signals used for connection with the external device in boot mode 5 (SCIF downloading).

Table 4.13 External Interface Signals Used in Boot Mode 5

Interface Module	Pin Name	I/O	Function	Pin Type
SCIF0	SCIF0_SCK* ¹	Input/output	SCIF0 serial clock	Multiplexed pins (3.3 V)
	SCIF0_RXD	Input	SCIF0 receive data	
	SCIF0_TXD	Output	SCIF0 transmit data	
	SCIF0_CTS#* ¹	Input/output	SCIF0 transmission enable	
	SCIF0_RTS#* ¹	Output	SCIF0 transmission request	

Note 1. This terminal is not used at boot time.

4.2.6.1 External Connections

Figure 4.17 shows the external connections for downloading through the SCIF.

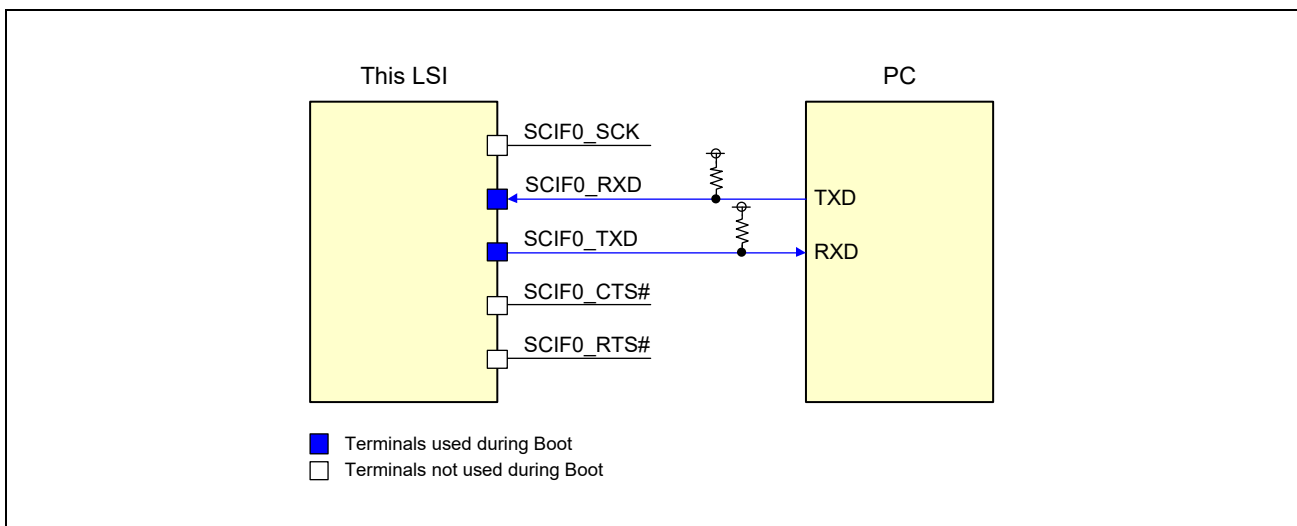

Figure 4.17 Connections for Downloading through the SCIF in Boot Mode 5

4.2.6.2 Overview of Operation

This mode is used to download the user program from the host PC. Upon detecting boot mode 5 according to the value read from the SYSC, the boot program makes the necessary settings of the SCIFA module to access memory. The boot program handles the following steps to control the booting process.

1. The SCIFA module is set up to handle communications as shown below. Asynchronous communications proceed in this mode. The SCIF0_RXD and SCIF0_TXD pins are used.
 - Baud rate: 115200 bps
 - Data length: 8 bits
 - Stop bit: 1 bit
 - Flow control: None
 - Data format: Motorola S-record
2. The sequence shown in **Figure 4.18** is used to download the user program through the SCIF.

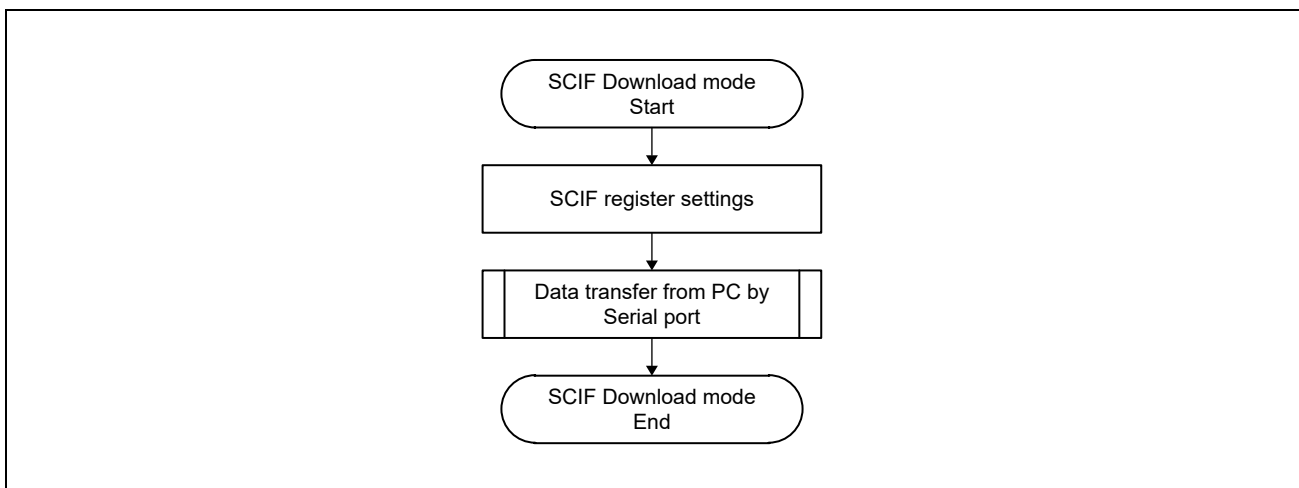

Figure 4.18 Sequence of Downloading through the SCIFA

4.2.6.3 Operation of Booting through SCIF Downloading

In boot mode 5 (booting through SCIF downloading), this LSI is booted from the loader program downloaded from the external host PC through the serial communications interface with FIFO (SCIFA).

The boot program executes the following processing.

1. Setting up the necessary peripheral modules (SCIFA channel 0 and GPIO) and specifying the parameters for communications.

When the LSI becomes ready for data reception, the boot program outputs the following message to the SCIFA.

“SCIF Download mode”

If execution enters boot mode 5 due to the fail-safe processing, the boot program outputs the following message to the SCIFA.

“SCIF Download mode due to parameter error”

2. Upon receiving the Motorola S0 record sent from the external host PC through the SCIFA, the boot program converts the S3 record to binary data and copies the data to the addresses H’0_0001_2000 to H’0_0002_EFFE (up to 116 Kbytes) of the on-chip RAM.

The boot program outputs the following message to the SCIFA.

“-- Load Program to System RAM -----”

Note: The S0 record must always be generated because the boot program requires an S0 record as a trigger for the reception processing.

3. Upon receiving the S7 record, the boot program outputs the following message to the SCIFA and terminates copying to the on-chip RAM. After that, execution branches to the address H’0_0001_2000 of the on-chip RAM.

“-- Start Boot Program on System RAM -----”

If the data in the Motorola S records sent from the external host PC satisfies any of the following error conditions, the corresponding error message is output to the SCIFA and copying to the on-chip RAM is aborted.

- An S1 or S2 record is received: “Invalid Record Type Error!!! ”
- An address outside the on-chip RAM area is specified: “Address Error!!! ”
- An illegal character code is found: “Invalid Character Error!!! ”
- An illegal byte count is found: “Invalid Byte Count Error!!! ”

The data transmission and reception operation in SCIF communications (asynchronous) is shown in **Figure 4.19**.

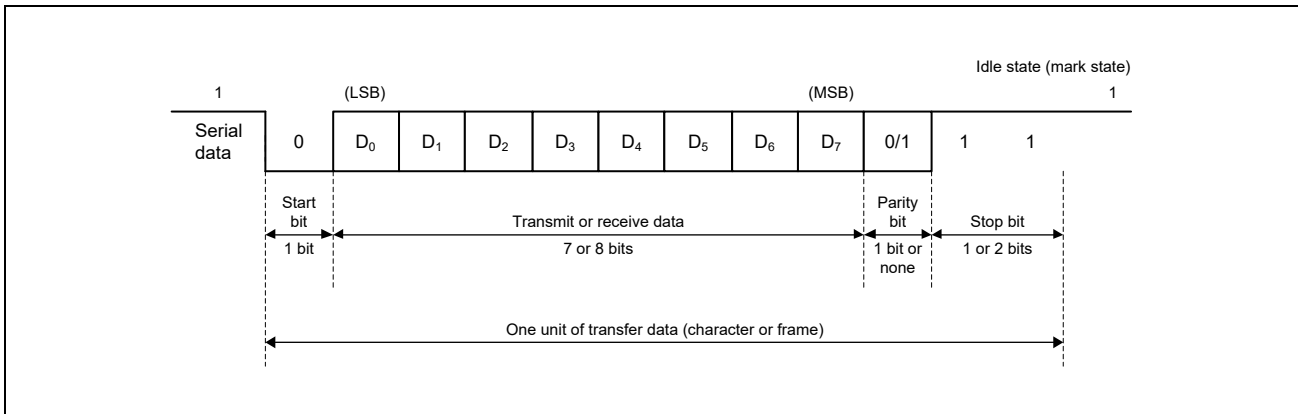

Figure 4.19 Data Transmission and Reception Operation in SCIF Communications

4.2.6.4 Allocation of the Loader Program for SCIF Downloading

Figure 4.20 shows the allocation of the loader program copied to the on-chip RAM.

In the loader program size block (512 bytes), the loader program size is stored in the first four bytes and the signature H'AA55 is stored in the last two bytes. Be sure to store the loader program size in 4-byte little endian.

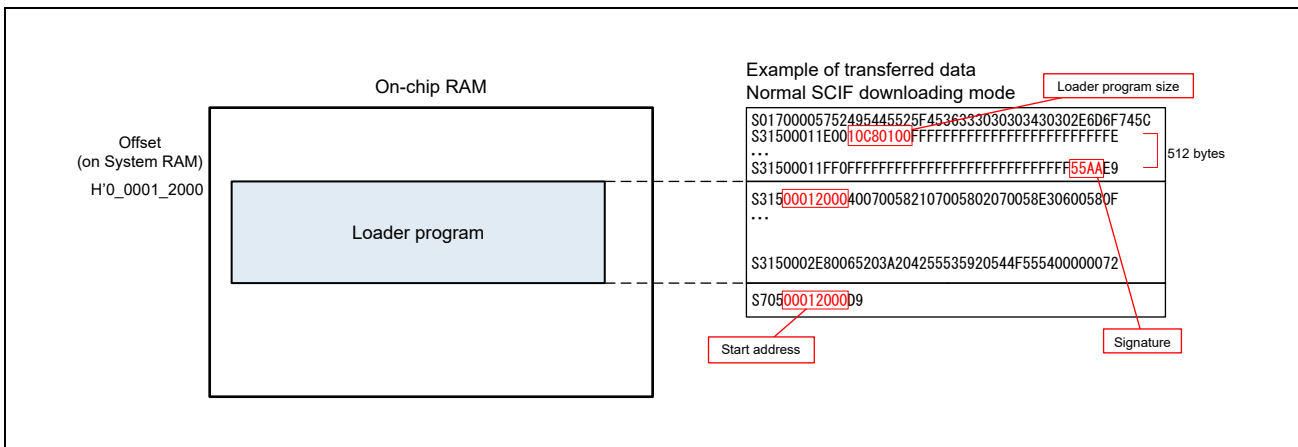

Figure 4.20 Allocation of the Loader Program for SCIF Downloading Copied to the On-chip RAM

4.2.6.5 Note

The pins assigned to the SCIF0_SCK, SCIF0_CTS, and SCIF0_RTS signals, which are not used in this mode, must not be changed from the initial settings (GPIO pins). If such a pin is set to operate as an SCIF0 pin, it becomes an input pin or an input/output pin. In this case, when the pin is externally placed in the Hi-Z state, this LSI cannot communicate with the host PC correctly.

To use the SCIFA for normal serial communications after booting, the SCIF0_SCK, SCIF0_CTS, and SCIF0_RTS pins should be pulled up or down in accordance with the communication mode and the driver software specifications.

5. LSI Internal Bus

5.1 Overview

5.1.1 Features

The bus system of this LSI provides a physical address space of 16 Gbytes (address bus width of 34 bits). The LSI internal bus of this LSI incorporates Arm CoreLink NIC-400, etc., and controls the following bus functions.

Security control:

Security attribute re-setting, Security level determination

Address translation:

34-bit address space access

Interrupt generation:

AXI bus error interrupt generation

Unit state detection:

Slave unit stop state detection

NOTE

The security control function is valid only for secure products.
For information on secure products, please contact our sales.

5.1.2 Block Diagram of LSI Internal Bus

The LSI internal bus of this LSI consists of the ACPU bus, MCPU bus, and system bus. **Figure 5.1** shows the configuration of the buses.

ACPU bus:

A bus connected to AX45MP, DDR memory controllers, image processing units, and Storage and Network

MCPU bus:

A bus connected to serial interface units

System bus:

A bus connected to the control registers of each unit

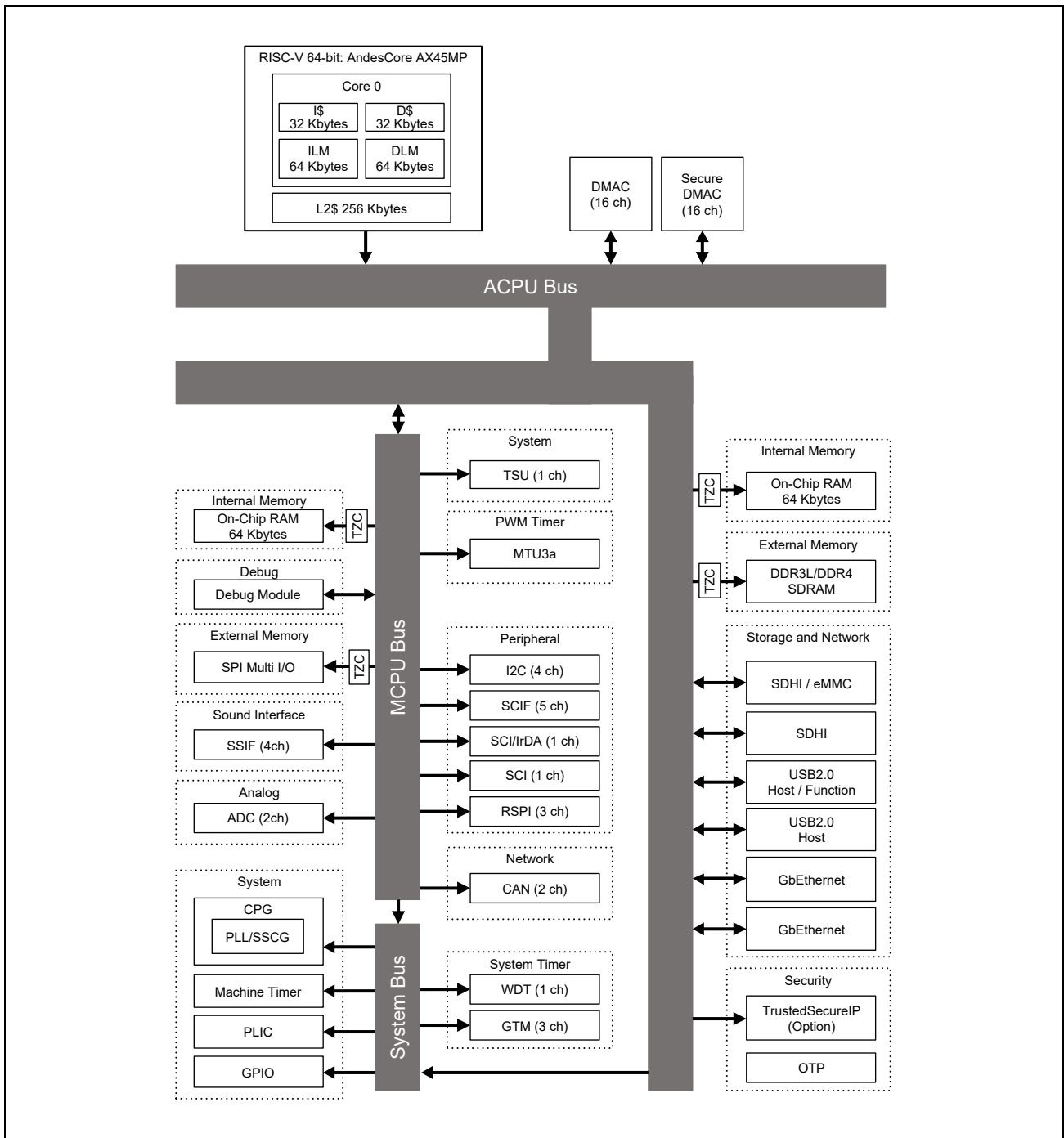

Figure 5.1 Configuration of LSI Internal Bus

5.2 Area Maps

5.2.1 Overall Address Space

Figure 5.2 shows the overall address space of this LSI and Table 5.1 shows the detailed address space.

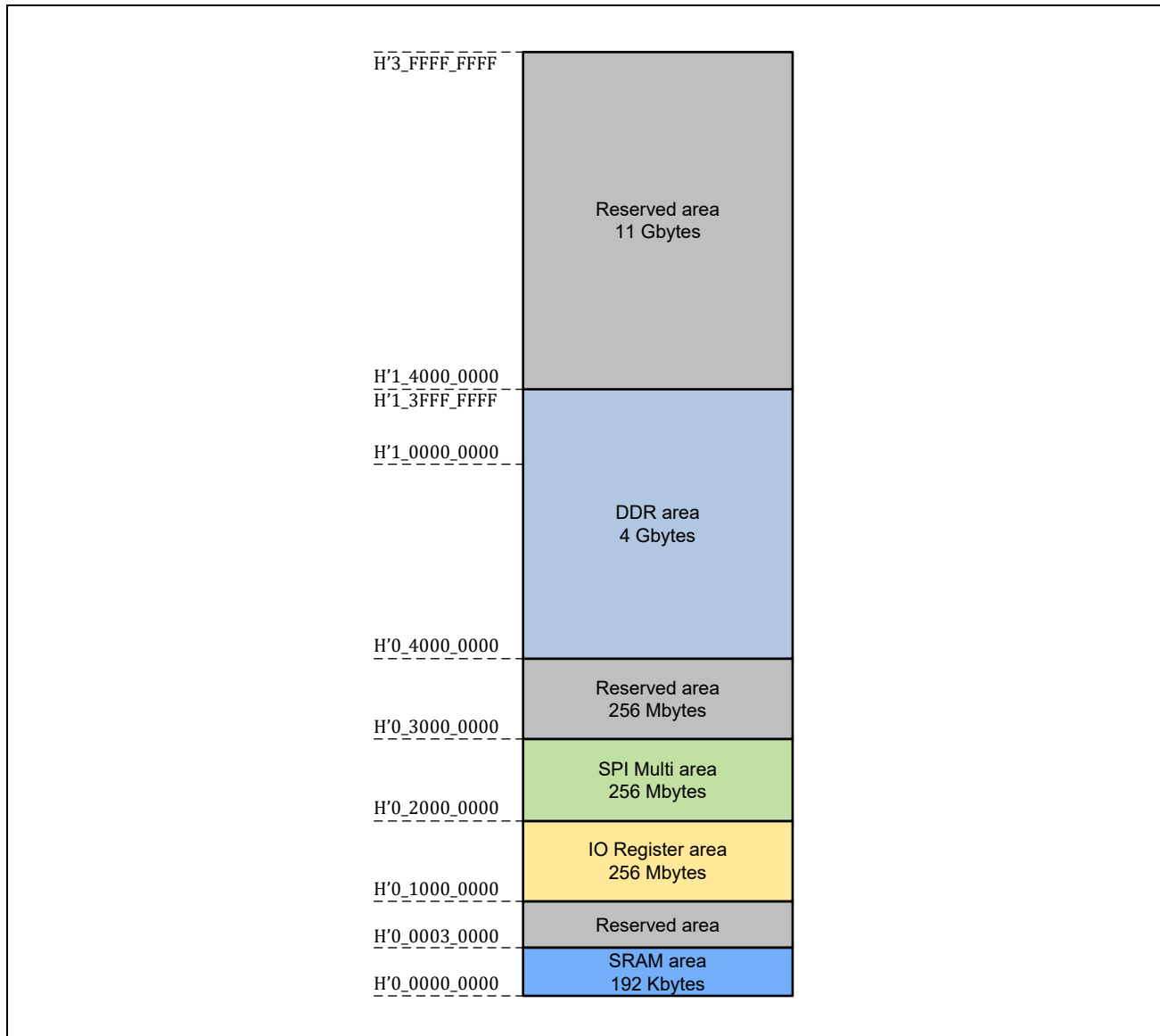

Figure 5.2 Overall Address Space

Some bus master units of this LSI require 34-bit address space access to access an address space of greater than 4 Gbytes in the whole 16-Gbyte address space of this LSI. For details, see **Section 5.4.2.1, 34-Bit Address Space Access**.

Table 5.1 Detailed Address Space (1/3)

Start Address	End Address	Size	Space	Remarks
H'1_4000_0000	H'3_FFFF_FFFF	11 Gbytes	Reserved	*1
H'0_4000_0000	H'1_3FFF_FFFF	4 Gbytes	DDR (Memory)	*2
H'0_3000_0000	H'0_3FFF_FFFF	256 Mbytes	Reserved	*1
H'0_2000_0000	H'0_2FFF_FFFF	256 Mbytes	SPI Multi I/O (Memory)	
H'0_1500_0000	H'0_1FFF_FFFF	176 Mbytes	Reserved	*1
H'0_14F0_0000	H'0_14FF_FFFF	1 Mbyte	Reserved	*1
H'0_14C0_0000	H'0_14EF_FFFF	3 Mbytes	Reserved	*1
H'0_14B0_0000	H'0_14BF_FFFF	1 Mbyte	Reserved	*1
H'0_1400_0000	H'0_14AF_FFFF	11 Mbytes	Reserved	*1
H'0_1350_0000	H'0_13FF_FFFF	11 Mbytes	Reserved	*1
H'0_1340_0000	H'0_134F_FFFF	1 Mbytes	L2C	
H'0_1300_0000	H'0_133F_FFFF	4 Mbytes	PLIC_SW	
H'0_12C0_0000	H'0_12FF_FFFF	4 Mbytes	PLIC	
H'0_12B0_0000	H'0_12BF_FFFF	1 Mbyte	Reserved	*1
H'0_12A0_0000	H'0_12AF_FFFF	1 Mbyte	Reserved	*1
H'0_1280_1C00	H'0_129F_FFFF	2041 Kbytes	Reserved	*1
H'0_1280_1800	H'0_1280_1BFF	1 Kbyte	GTM ch2	
H'0_1280_1400	H'0_1280_17FF	1 Kbyte	GTM ch1	
H'0_1280_1000	H'0_1280_13FF	1 Kbyte	GTM ch0	
H'0_1280_0C00	H'0_1280_0FFF	1 Kbyte	Reserved	*1
H'0_1280_0800	H'0_1280_0BFF	1 Kbyte	WDT AX45MP	
H'0_1280_0400	H'0_1280_07FF	1 Kbyte	Reserved	*1
H'0_1280_0000	H'0_1280_03FF	1 Kbyte	Reserved	*1
H'0_1270_0000	H'0_127F_FFFF	1 Mbyte	Reserved	*1
H'0_1240_0000	H'0_126F_FFFF	3 Mbytes	Reserved	*1
H'0_1230_0000	H'0_123F_FFFF	1 Mbyte	Reserved	*1
H'0_1200_0000	H'0_122F_FFFF	3 Mbytes	Reserved	*1
H'0_11F0_0000	H'0_11FF_FFFF	1 Mbyte	Reserved	*1
H'0_11C8_0000	H'0_11EF_FFFF	2560 Kbytes	Reserved	*1
H'0_11C7_0000	H'0_11C7_FFFF	64 Kbytes	USB2.0 ch1 Host	
H'0_11C6_0000	H'0_11C6_FFFF	64 Kbytes	USB2.0 ch0 (OTG-Func)	
H'0_11C5_0000	H'0_11C5_FFFF	64 Kbytes	USB2.0 ch0 (OTG-Host)	
H'0_11C4_0000	H'0_11C4_FFFF	64 Kbytes	USBPHY Control	
H'0_11C3_0000	H'0_11C3_FFFF	64 Kbytes	Ether ch1	
H'0_11C2_0000	H'0_11C2_FFFF	64 Kbytes	Ether ch0	
H'0_11C1_0000	H'0_11C1_FFFF	64 Kbytes	SD ch1	
H'0_11C0_0000	H'0_11C0_FFFF	64 Kbytes	SD ch0	
H'0_11B0_0000	H'0_11BF_FFFF	1 Mbyte	Reserved	*1
H'0_11A0_0000	H'0_11AF_FFFF	1 Mbyte	Reserved	*1
H'0_1190_0000	H'0_119F_FFFF	1 Mbyte	Reserved	*1
H'0_1187_0000	H'0_118F_FFFF	1 Mbyte	Reserved	*1
H'0_1186_0000	H'0_1186_FFFF	64 Kbytes	OTP	
H'0_1185_0000	H'0_1185_FFFF	64 Kbytes	Reserved	*1
H'0_1184_0000	H'0_1184_FFFF	64 Kbytes	Reserved	*1
H'0_1183_0000	H'0_1183_FFFF	64 Kbytes	Non Secure DMAC (DMAC_NS) APB	

Table 5.1 Detailed Address Space (2/3)

Start Address	End Address	Size	Space	Remarks
H'0_1182_0000	H'0_1182_FFFF	64 Kbytes	Non Secure DMAC (DMAC_NS) AXI	
H'0_1181_0000	H'0_1181_FFFF	64 Kbytes	Secure DMAC (DMAC_S) APB	
H'0_1180_0000	H'0_1180_FFFF	64 Kbytes	Secure DMAC (DMAC_S) AXI	
H'0_1170_0000	H'0_117F_FFFF	1 Mbyte	Reserved	*1
H'0_1142_0000	H'0_116F_FFFF	2944 Kbytes	Reserved	*1
H'0_1141_0000	H'0_1141_FFFF	64 Kbytes	DDR (Control Reg)	
H'0_1140_0000	H'0_1140_FFFF	64 Kbytes	DDR (PHY)	
H'0_1130_0000	H'0_113F_FFFF	1 Mbyte	Reserved	*1
H'0_110C_0000	H'0_112F_FFFF	2240 Kbytes	Reserved	*1
H'0_110C_0000	H'0_110C_FFFF	64 Kbytes	Machine Timer	
H'0_110A_0000	H'0_110B_FFFF	128 Kbytes	IAX45 (Interrupt controller)	
H'0_1109_0000	H'0_1109_FFFF	64 Kbytes	SRAM MCPU (Reg)	
H'0_1108_0000	H'0_1108_FFFF	64 Kbytes	SRAM ACPU (Reg)	
H'0_1107_0000	H'0_1107_FFFF	64 Kbytes	TZC (DDR)	
H'0_1106_0000	H'0_1106_FFFF	64 Kbytes	TZC (SPI Multi I/O)	
H'0_1105_0000	H'0_1105_FFFF	64 Kbytes	TZC (SRAM MCPU)	
H'0_1104_0000	H'0_1104_FFFF	64 Kbytes	TZC (SRAM ACPU)	
H'0_1103_0000	H'0_1103_FFFF	64 Kbytes	GPIO	
H'0_1102_0000	H'0_1102_FFFF	64 Kbytes	SYSC	
H'0_1101_0000	H'0_1101_FFFF	64 Kbytes	CPG	
H'0_1100_0000	H'0_1100_FFFF	64 Kbytes	Reserved	*1
H'0_10C0_0000	H'0_10FF_FFFF	4 Mbytes	Debug Module	
H'0_10B0_0000	H'0_10BF_FFFF	1 Mbyte	Reserved	*1
H'0_108A_0000	H'0_10AF_FFFF	2432 Kbytes	Reserved	*1
H'0_1089_0000	H'0_1089_FFFF	64 Kbytes	Reserved	*1
H'0_1088_0000	H'0_1088_FFFF	64 Kbytes	Reserved	*1
H'0_1087_0000	H'0_1087_FFFF	64 Kbytes	Reserved	*1
H'0_1086_0000	H'0_1086_FFFF	64 Kbytes	Reserved	*1
H'0_1085_0000	H'0_1085_FFFF	64 Kbytes	Reserved	*1
H'0_1084_0000	H'0_1084_FFFF	64 Kbytes	Reserved	*1
H'0_1083_0000	H'0_1083_FFFF	64 Kbytes	Reserved	*1
H'0_1082_0000	H'0_1082_FFFF	64 Kbytes	Reserved	*1
H'0_1081_0000	H'0_1081_FFFF	64 Kbytes	Reserved	*1
H'0_1080_0000	H'0_1080_FFFF	64 Kbytes	Reserved	*1
H'0_1070_0000	H'0_107F_FFFF	1 Mbyte	Reserved	*1
H'0_1060_0000	H'0_106F_FFFF	1 Mbyte	Reserved	*1
H'0_1041_0000	H'0_105F_FFFF	1984 Kbytes	Reserved	*1
H'0_1040_0000	H'0_1040_FFFF	64 Kbytes	Reserved	*1
H'0_1030_0000	H'0_103F_FFFF	1 Mbyte	Reserved	*1
H'0_1020_0000	H'0_102F_FFFF	1 Mbyte	Reserved	*1
H'0_1008_0000	H'0_101F_FFFF	1536 Kbytes	Reserved	*1
H'0_1007_0000	H'0_1007_FFFF	64 Kbytes	SPI Multi I/O (Write Buf)	
H'0_1006_0000	H'0_1006_FFFF	64 Kbytes	SPI Multi I/O (Reg)	
H'0_1005_9800	H'0_1005_FFFF	26 Kbytes	Reserved	*1
H'0_1005_9400	H'0_1005_97FF	1 Kbyte	TSU	

Table 5.1 Detailed Address Space (3/3)

Start Address	End Address	Size	Space	Remarks
H'0_1005_9000	H'0_1005_93FF	1 Kbyte	ADC	
H'0_1005_8C00	H'0_1005_8FFF	1 Kbyte	I2C ch3	
H'0_1005_8800	H'0_1005_8BFF	1 Kbyte	I2C ch2	
H'0_1005_8400	H'0_1005_87FF	1 Kbyte	I2C ch1	
H'0_1005_8000	H'0_1005_83FF	1 Kbyte	I2C ch0	
H'0_1005_0000	H'0_1005_7FFF	32 Kbytes	CANFD	
H'0_1004_D800	H'0_1004_FFFF	10 Kbytes	Reserved	*1
H'0_1004_D400	H'0_1004_D7FF	1 Kbyte	SCI ch1	
H'0_1004_D000	H'0_1004_D3FF	1 Kbyte	SCI ch0	
H'0_1004_CC00	H'0_1004_CFFF	1 Kbyte	IrDA (SCI)	
H'0_1004_C800	H'0_1004_CBFF	1 Kbyte	SCIF ch4	
H'0_1004_C400	H'0_1004_C7FF	1 Kbyte	SCIF ch3	
H'0_1004_C000	H'0_1004_C3FF	1 Kbyte	SCIF ch2	
H'0_1004_BC00	H'0_1004_BFFF	1 Kbyte	SCIF ch1	
H'0_1004_B800	H'0_1004_BBFF	1 Kbyte	SCIF ch0	
H'0_1004_B400	H'0_1004_B7FF	1 Kbyte	RSPI ch2	
H'0_1004_B000	H'0_1004_B3FF	1 Kbyte	RSPI ch1	
H'0_1004_AC00	H'0_1004_AFFF	1 Kbyte	RSPI ch0	
H'0_1004_A800	H'0_1004_ABFF	1 Kbyte	SSIF ch3	
H'0_1004_A400	H'0_1004_A7FF	1 Kbyte	SSIF ch2	
H'0_1004_A000	H'0_1004_A3FF	1 Kbyte	SSIF ch1	
H'0_1004_9C00	H'0_1004_9FFF	1 Kbyte	SSIF ch0	
H'0_1004_9800	H'0_1004_9BFF	1 Kbyte	POE3	
H'0_1004_9400	H'0_1004_97FF	1 Kbyte	Reserved	*1
H'0_1004_9000	H'0_1004_93FF	1 Kbyte	Reserved	*1
H'0_1004_8C00	H'0_1004_8FFF	1 Kbyte	Reserved	*1
H'0_1004_8800	H'0_1004_8BFF	1 Kbyte	Reserved	*1
H'0_1004_8000	H'0_1004_87FF	2 Kbytes	Reserved	*1
H'0_1004_7000	H'0_1004_7FFF	4 Kbytes	Reserved	
H'0_1004_0000	H'0_1004_6FFF	28 Kbytes	Reserved	
H'0_1000_0000	H'0_1003_FFFF	256 Kbytes	MTU3a	
H'0_0005_0000	H'0_0FFF_FFFF	261824 Kbytes	Reserved	*1
H'0_0004_0000	H'0_0004_FFFF	64 Kbytes	DLM	*3
H'0_0003_0000	H'0_0003_FFFF	64 Kbytes	ILM	*3
H'0_0002_0000	H'0_0002_FFFF	64 Kbytes	SRAM ACPU (Memory)	
H'0_0001_0000	H'0_0001_FFFF	64 Kbytes	SRAM MCPU (Memory)	
H'0_0000_0000	H'0_0000_FFFF	64 Kbytes	Reserved	*1

Note 1. Access to the reserved areas is prohibited.

If access to the reserved area is attempted, incorrect operation may occur.

Note 2. Access to the addresses H'4000_0000 to H'4000_001F (for DDR3L) or H'4000_0000 to H'4000_003F (for DDR4) in the DDR area is prohibited because these are used for DDR training. For details, see **Section 9, DDR3L/DDR4 SDRAM Memory Controller (MEMC)**.

Note 3. This area can only be accessed by the AX45MP.

5.3 Accessible Areas

In the bus system of this LSI, each bus master unit can only access the areas that are used for register access or data transfer. **Table 5.2** shows the areas that can be accessed from each master. The register area of TZC can be accessed only when Secure (AxPROT[1] = 0).

Table 5.2 Accessible Areas (1/2)

Slave Unit	Master Unit						
	AX45MP	DMAC_S	DMAC_NS	Debug Module	SDHI (ch0, ch1)	Getther (ch0, ch1)	USB2.0 (ch0, ch1)
DDR (Memory)	✓	✓	✓	✓	✓	✓	✓
SRAM ACPU (Memory)	✓	✓	✓	✓	✓	✓	✓
SRAM MCPU (Memory)	✓	✓	✓	✓	✓	✓	✓
SPI Multi I/O (Memory/Reg)	✓	✓	✓	✓	x	x	x
I2C (ch0 to ch3)	✓	✓	✓	✓	x	x	x
CANFD	✓	✓	✓	✓	x	x	x
ADC	✓	✓	✓	✓	x	x	x
TSU	✓	✓	✓	✓	x	x	x
POE3	✓	✓	✓	✓	x	x	x
MTU3a	✓	✓	✓	✓	x	x	x
SSIF (ch0 to ch3)	✓	✓	✓	✓	x	x	x
RSPI (ch0 to ch2)	✓	✓	✓	✓	x	x	x
SCIF (ch0 to ch4)	✓	✓	✓	✓	x	x	x
IrDA (SCI)	✓	✓	✓	✓	x	x	x
SCI (ch0, ch1)	✓	✓	✓	✓	x	x	x
WDT (ch0)	✓	✓	✓	✓	x	x	x
GTM (ch0 to ch2)	✓	✓	✓	✓	x	x	x
OTP	✓	✓	✓	✓	x	x	x
DMAC_S	✓	✓	✓	✓	x	x	x
DMAC_NS	✓	✓	✓	✓	x	x	x
SDHI (ch0, ch1)	✓	✓	✓	✓	x	x	x
Ether (ch0, ch1)	✓	✓	✓	✓	x	x	x
USBPHY Control	✓	✓	✓	✓	x	x	x
USB2.0 ch0 (OTG-Host)	✓	✓	✓	✓	x	x	x
USB2.0 ch0 (OTG-Func)	✓	✓	✓	✓	x	x	x
USB2.0 ch1 Host	✓	✓	✓	✓	x	x	x
Debug Module	✓	✓	✓	✓	x	x	x
SYSC	✓	✓	✓	✓	x	x	x
SRAM ACPU (Reg)	✓	✓	✓	✓	x	x	x
SRAM MCPU (Reg)	✓	✓	✓	✓	x	x	x
TZC (SRAM ACPU)	✓	✓	x*1	✓	x	x	x
TZC (SRAM MCPU)	✓	✓	x*1	✓	x	x	x

Table 5.2 Accessible Areas (2/2)

Slave Unit	Master Unit						
	AX45MP	DMAC_S	DMAC_NS	Debug Module	SDHI (ch0, ch1)	Gether (ch0, ch1)	USB2.0 (ch0, ch1)
TZC (SPI Multi I/O)	✓	✓	x*1	✓	x	x	x
TZC (DDR)	✓	✓	x*1	✓	x	x	x
Machine Timer	✓	✓	✓	✓	x	x	x
GPIO	✓	✓	✓	✓	x	x	x
CPG	✓	✓	✓	✓	x	x	x
IAX45 (Interrupt controller)	✓	✓	✓	✓	x	x	x
PLIC	✓	✓	✓	✓	x	x	x
PLIC_SW	✓	✓	✓	✓	x	x	x
DDR (Control Reg)	✓	✓	✓	✓	x	x	x
DDR (PHY)	✓	✓	✓	✓	x	x	x

Note 1. Access to TZC-400 registers is prohibited because DMAC_NS is always fixed to the Non-secure state and unprivileged mode by control signals from the SYSC.

Remarks: ✓: Accessible path, ×: Prohibited path

Note: Usage of paths marked with × in the table is prohibited.
If access to such a path is attempted, incorrect operation may occur.

5.4 Bus System Control

5.4.1 Security Control

5.4.1.1 Re-Setting the Security Attribute Output from Bus Masters

This facility is for re-setting the security attributes of bus transactions that are by bus master units. Specifically, use the master access control register (SYS_MSTACCCTLn: n = 0 to 4) to re-set the security attributes. For details on the SYS_MSTACCCTLn register, see **Section 6.3, Register Descriptions**.

NOTE

The bus transaction signals ARPROT[1:0] and AWPROT[1:0] indicate the security attributes, which can be used to protect against illicit transactions.

- ARPROT[0] and AWPROT[0] being 0 or 1 respectively indicate non-privileged access or privileged access.
- ARPROT[1] and AWPROT[1] being 0 or 1 respectively indicate secure access or non-secure access.

The ARPROT and AWPROT signals are prescribed in as part of the AXI protocol. For details, see the AMBA AXI and ACE Protocol Specifications published by Arm Ltd.

Use the SYS_MSTACCCTLn register to make the following settings.

- Selection of security attribute source
 - Selection of whether to use the unchanged values of ARPROT[1:0] or AWPROT[1:0] of the ARPROT[2:0] or AWPROT[2:0] signals, which are output from the bus master units, or to re-set ARPROT[1:0] or AWPROT[1:0] according to the settings of the SYS_MSTACCCTL register
- Value to be re-set for ARPROT[1:0] or AWPROT[1:0]

Table 5.3 shows the relation between the registers and bits for use in re-setting the security attributes and the target masters for control.

Table 5.3 List of Register Bits for Use in Re-setting of Security Attributes

Target Master for Control*1	Control Register*2	Write Access Control Bits*3,*4			Read Access Control Bits*3,*5		
		Bit for use in re-setting the security attributes immediately below		Bit for use in selecting the security attribute source	Bit for use in re-setting the security attributes immediately below		Bit for use in selecting the security attribute source
		AWPROT[0]	AWPROT[1]		ARPROT[0]	ARPROT[1]	
Secure DMAC	SYS_MSTACCC TL0	Bit 0: AWPU	Bit 1: AWNS	Bit 3: AWSEL	Bit 4: ARPU	Bit 5: ARNS	Bit 7: ARSEL
Non-Secure DMAC*6	SYS_MSTACCC TL0	Bit 8: AWPU	Bit 9: AWNS	Bit 11: AWSEL	Bit 12: ARPU	Bit 13: ARNS	Bit 15: ARSEL
SDHI/eMMC ch0	SYS_MSTACCC TL1	Bit 0: AWPU	Bit 1: AWNS	Bit 3: AWSEL	Bit 4: ARPU	Bit 5: ARNS	Bit 7: ARSEL
SDHI ch1	SYS_MSTACCC TL1	Bit 8: AWPU	Bit 9: AWNS	Bit 11: AWSEL	Bit 12: ARPU	Bit 13: ARNS	Bit 15: ARSEL
GbEthernet ch0	SYS_MSTACCC TL1	Bit 16: AWPU	Bit 17: AWNS	Bit 19: AWSEL	Bit 20: ARPU	Bit 21: ARNS	Bit 23: ARSEL
GbEthernet ch1	SYS_MSTACCC TL1	Bit 24: AWPU	Bit 25: AWNS	Bit 27: AWSEL	Bit 28: ARPU	Bit 29: ARNS	Bit 31: ARSEL
USB2.0 ch0 Host*7	SYS_MSTACCC TL2	Bit 0: AWPU	Bit 1: AWNS	Bit 3: AWSEL	Bit 4: ARPU	Bit 5: ARNS	Bit 7: ARSEL
USB2.0 ch1 Host*7	SYS_MSTACCC TL2	Bit 8: AWPU	Bit 9: AWNS	Bit 11: AWSEL	Bit 12: ARPU	Bit 13: ARNS	Bit 15: ARSEL
USB2.0 ch0 Function*7	SYS_MSTACCC TL2	Bit 16: AWPU	Bit 17: AWNS	Bit 19: AWSEL	Bit 20: ARPU	Bit 21: ARNS	Bit 23: ARSEL

Note 1. Re-setting of security attributes for the AX45MP and Debug Module bus masters is not possible.

Note 2. See **Section 6.3, Register Descriptions** for details on the registers.

Note 3. See **Section 6.3, Register Descriptions** for details on the bits.

Note 4. The values set in AWPU and AWNS are effective when the setting of the corresponding AWSEL bit is 1. For details, see the specifications of the registers in **Section 6.3, Register Descriptions**.

Note 5. The values set in ARPU and ARNS are effective when the setting of the corresponding ARSEL bit is 1. For details, see the specifications of the registers in **Section 6.3, Register Descriptions**.

Note 6. AWPU and ARPU, AWNS and ARNS, and AWSEL and ARSEL for use in control of the non-secure DMAC are respectively fixed to 1, 1, 0, 0, and 1, 1. Accordingly, access to the non-secure DMAC is always non-secure and non-privileged.

Note 7. When the setting of AWSEL for use in control of the USB2.0 module is 0, the values in AWPROT[0] and ARPROT[0] are the same as the value of HPROT[1] output from the USB2.0 module, and the values of AWPROT[1] and ARPROT[1] are always 1. For control of HPROT[1] in the USB2.0 module, see **Section 32A, USB 2.0 Host Module**, and **Section 32B, USB 2.0 Function Module**. The HPROT signal is prescribed in the HB-Lite protocol. For details, see the AMBA 3 AHB-Lite Protocol Specification published by Arm Ltd.

5.4.1.2 Determining the Security Levels of Bus Slaves

This facility is for enabling or disabling access to a bus slave unit by comparing the security attribute that is input to the bus slave unit in a bus transaction with the security setting of the given slave. The security level can be set in one of the following ways. The applicable way depends on the slave.

- Setting by using the SL[1:0] bits in the slave control register (SYS_SLVACCCTLn: n = 0 to 8, 10, 12 to 14)
- Setting by using the nsaid_wr_en[31:16] and nsaid_rd_en[15:0] bits in the region ID access register (REGION_ID_ACCESS_<n>: n = 0 to 2) of the address space controller (TZC). For details on the TZC, see **Section 13, Address Space Controller (TZC)**.

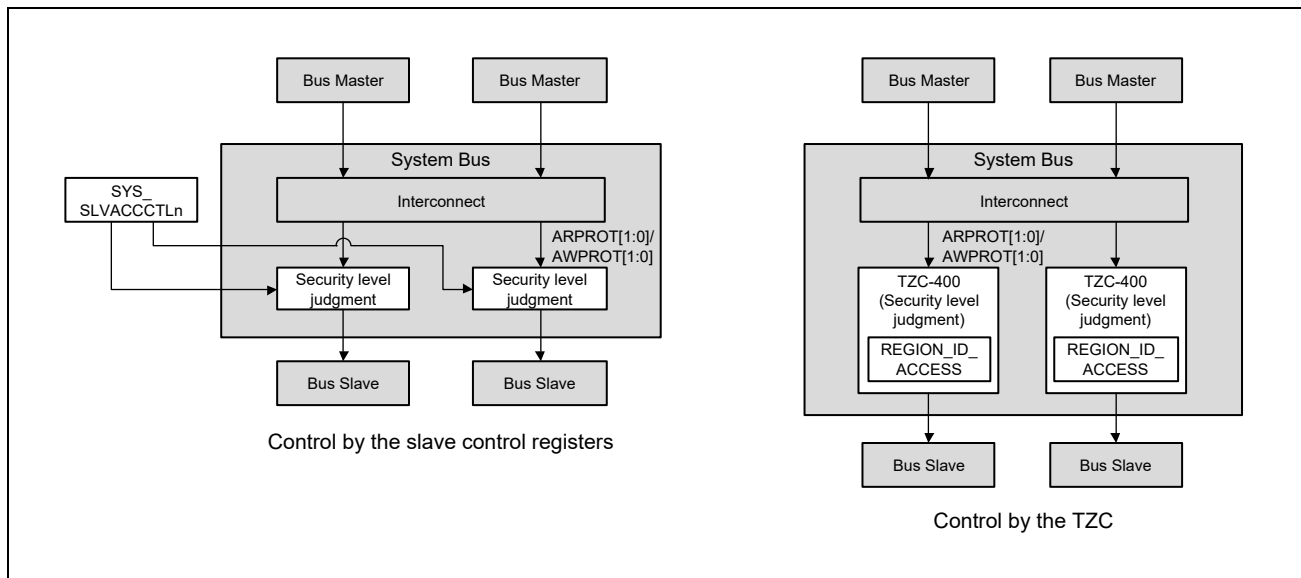

Figure 5.3 Security level determination ways

NOTE

The bus transaction signals ARPROT[1:0] and AWPROT[1:0] indicate the security attributes, which can be used to protect against illicit transactions.

- ARPROT[0] and AWPROT[0] being 0 or 1 respectively indicate non-privileged access or privileged access.
- ARPROT[1] and AWPROT[1] being 0 or 1 respectively indicate secure access or non-secure access.

The ARPROT and AWPROT signals are prescribed in as part of the AXI protocol. For details, see the AMBA AXI and ACE Protocol Specifications published by Arm Ltd.

Table 5.4 shows the correspondence between the settings of the slave control register and the security levels for input transactions. **Table 5.5** shows the correspondence between the settings of the region ID access register of the TZC and the security levels for input bus transactions.

If comparison indicates that access is disabled, a bus error is generated in response to the corresponding attempted bus transaction. Stopping of a slave unit is detected by reference to the module stop state (MSTOP) setting in the CPG. Attempted access to a slave unit in the module stop state leads to a bus error.

Table 5.4 Security Levels Set by Using the Slave Control Register

Setting of SL[1:0]	Security Attribute for Input Bus Transactions			
	Non-privileged Non-secure	Privileged Non-secure	Non-privileged Secure	Privileged Secure
00	Access allowed	Access allowed	Access allowed	Access allowed
01	Access not allowed	Access allowed	Access allowed	Access allowed
10	Access not allowed	Access not allowed	Access allowed	Access allowed
11	Access not allowed	Access not allowed	Access not allowed	Access allowed

Table 5.5 Security Levels Set by Using the TZC

Setting of nsaid_wr_en[31:16] and nsaid_rd_en[15:0]	Security Attribute for Input Bus Transactions			
	Non-privileged Non-secure	Privileged Non-secure	Non-privileged Secure	Privileged Secure
H'000F	Access allowed	Access allowed	Access allowed	Access allowed
H'000B	Access not allowed	Access allowed	Access allowed	Access allowed
H'0003	Access not allowed	Access not allowed	Access allowed	Access allowed
H'0002	Access not allowed	Access not allowed	Access not allowed	Access allowed

Table 5.6 lists the bus slaves for which the security levels are determined by using the slave control registers (SYS_SLVACCCTLn: n = 0 to 8, 10, 12 to 14). **Table 5.7** lists the bus slaves for which security levels are determined by using the region ID access registers (REGION_ID_ACCESS_<n>) of the TZC.

Table 5.6 Bus Slaves for which the Security Levels are Determined by Using the Slave Control Registers (1/2)

Target Bus Slave for Control*1	Control Register*2	SL[1:0] Allocation Bits*3
SRAM ACPU (Reg)	SYS_SLVACCCTL0	Bits [1:0]
SRAM MCPU (Reg)	SYS_SLVACCCTL0	Bits [3:2]
TZC (SRAM ACPU) (Reg)	SYS_SLVACCCTL1	Bits [1:0]
TZC (SRAM MCPU) (Reg)	SYS_SLVACCCTL1	Bits [3:2]
TZC (SPI Multi I/O) (Reg)	SYS_SLVACCCTL1	Bits [5:4]
TZC (DDR) (Reg)	SYS_SLVACCCTL1	Bits [7:6]
Debug Module	SYS_SLVACCCTL1	Bits [11:10]
CPG	SYS_SLVACCCTL1	Bits [13:12]
SYSC	SYS_SLVACCCTL1	Bits [15:14]
Machine Timer	SYS_SLVACCCTL1	Bits [17:16]
PLIC	SYS_SLVACCCTL1	Bits [19:18]
IAX45	SYS_SLVACCCTL1	Bits [21:20]
GPIO	SYS_SLVACCCTL1	Bits [23:22]
Secure DMAC	SYS_SLVACCCTL1	Bits [27:26]
Non-Secure DMAC	SYS_SLVACCCTL1	Bits [29:28]
GTM (channel 0)	SYS_SLVACCCTL2	Bits [1:0]
GTM (channel 1)	SYS_SLVACCCTL2	Bits [3:2]
GTM (channel 2)	SYS_SLVACCCTL2	Bits [5:4]
WDT (channel 0)	SYS_SLVACCCTL2	Bits [7:6]
MTU3a	SYS_SLVACCCTL2	Bits [15:14]
POE3	SYS_SLVACCCTL2	Bits [17:16]
DDR3L/4 Controller (Reg)	SYS_SLVACCCTL2	Bits [23:22]

Table 5.6 Bus Slaves for which the Security Levels are Determined by Using the Slave Control Registers (2/2)

Target Bus Slave for Control*1	Control Register*2	SL[1:0] Allocation Bits*3
USBPHY Control	SYS_SLVACCCTL3	Bits [17:16]
USB2.0 (channel 0)	SYS_SLVACCCTL3	Bits [19:18]
USB2.0 (channel 1)	SYS_SLVACCCTL3	Bits [21:20]
SDHI/eMMC (channel 0)	SYS_SLVACCCTL3	Bits [23:22]
SHDI (channel 1)	SYS_SLVACCCTL3	Bits [25:24]
GbEthernet (channel 0)	SYS_SLVACCCTL3	Bits [27:26]
GbEthernet (channel 1)	SYS_SLVACCCTL3	Bits [29:28]
I2C (channel 0)	SYS_SLVACCCTL4	Bits [1:0]
I2C (channel 1)	SYS_SLVACCCTL4	Bits [3:2]
I2C (channel 2)	SYS_SLVACCCTL4	Bits [5:4]
I2C (channel 3)	SYS_SLVACCCTL4	Bits [7:6]
CANFD	SYS_SLVACCCTL4	Bits [9:8]
RSPI	SYS_SLVACCCTL4	Bits [11:10]
SCIF (channel 0)	SYS_SLVACCCTL4	Bits [17:16]
SCIF (channel 1)	SYS_SLVACCCTL4	Bits [19:18]
SCIF (channel 2)	SYS_SLVACCCTL4	Bits [21:20]
SCIF (channel 3)	SYS_SLVACCCTL4	Bits [23:22]
SCIF (channel 4)	SYS_SLVACCCTL4	Bits [25:24]
SCI (channel 0)	SYS_SLVACCCTL4	Bits [27:26]
SCI (channel 1)	SYS_SLVACCCTL4	Bits [29:28]
SCI (channel 0) (IrDA)	SYS_SLVACCCTL4	Bits [31:30]
SSIF	SYS_SLVACCCTL5	Bits [1:0]
ADC	SYS_SLVACCCTL6	Bits [1:0]
TSU	SYS_SLVACCCTL6	Bits [3:2]
OTP	SYS_SLVACCCTL7	Bits [3:2]
Registers within the SYSC to control the AX45MP*4	SYS_SLVACCCTL8	Bits [5:4]
Register within the SYSC to control the LSI*4	SYS_SLVACCCTL10	Bits [1:0]
Registers within the SYSC to control the AOF*4	SYS_SLVACCCTL12	Bits [1:0]
Registers within the SYSC to control the Low Power Mode*4	SYS_SLVACCCTL13	Bits [1:0]
General-purpose registers within the SYSC*4	SYS_SLVACCCTL14	Bits [1:0]

Note 1. The security levels for the following bus slaves incorporated in this product are determined by using TZC-400. For details on the registers for controlling the security levels of these bus slaves, see **Table 5.7**.

- DDR3L and DDR4
- Memory areas of the SRAM ACU and SRAM MCPU
- Memory area, write buffer area, and control register area of SPI Multi I/O

Note 2. See **Section 6.3, Register Descriptions** for details on the registers.

Note 3. See **Section 6.3, Register Descriptions** for details on the bits.

Note 4. The SYSC has registers to control these functions. Setting of the security levels for each of the functions is possible. For details on the SYSC registers, see **Section 6.3, Register Descriptions**.

Table 5.7 Bus Slaves for which Security Levels are Determined by Using the Region ID Access Registers of the TZC

Target Bus Slave for Control	Security Control Unit (locations of the control registers)	Control Register* ¹	Control Bits* ²
DDR	TZC (DDR)	REGION_ID_ACCESS_<n> (n: 0,1,2)* ³	nsaid_wr_en[31:16], nsaid_rd_en[15:0]
SPI Multi I/O	TZC (SPI Multi I/O)	REGION_ID_ACCESS_0	nsaid_wr_en[31:16], nsaid_rd_en[15:0]
SRAM MCPU	TZC (SRAM MCPU)	REGION_ID_ACCESS_0	nsaid_wr_en[31:16], nsaid_rd_en[15:0]
SRAM ACPU	TZC (SRAM ACPU)	REGION_ID_ACCESS_0	nsaid_wr_en[31:16], nsaid_rd_en[15:0]

Note 1. For details on the related registers, see the Technical Reference Manual of CoreLink TZC-400 TrustZone Address Space Controller published by Arm Ltd.

Note 2. For details on the related bits, see the Technical Reference Manual of CoreLink TZC-400 TrustZone Address Space Controller published by Arm Ltd.

Note 3. REGION_ID_ACCESS_0 is for setting the security level for access to the DDR memory by using port 0 of the MEMC. REGION_ID_ACCESS_1 is for setting the security level for access to the DDR memory by using port 1 of the MEMC. REGION_ID_ACCESS_2 is for setting the security level for access to the DDR memory by using port 2 of the MEMC. See **Section 13.1.2, Block Diagram** and **Figure 13.1** for the port number of the MEMC for use in access to the DDR memory from the bus masters.

5.4.2 Address Translation

5.4.2.1 34-Bit Address Space Access

This LSI has bus master units that can handle up to a 34-bit address space and bus master units that can only handle up to a 32-bit address space (actual size of 4 Gbytes). This function enables a bus master unit that can only handle up to a 32-bit address space (actual size of 4 Gbytes) to access an address space of greater than 4 Gbytes. The target bus master units are as follows.

- SDHI/eMMC
- GEthernet
- USB2.0
- DMAC

This function translates bus transaction addresses that are output from a bus master unit in 1-Gbyte units according to the settings of the address offset registers (SYS_AOFn: n = 0 to 6), as shown in the figure below. For details on the SYS_AOFn register, see **Section 6.3, Register Descriptions** in **Section 6, System Controller (SYSC)**.

- In the SYS_AOF registers, set bits [33:30] of the remapping destination address in each 1-Gbyte space corresponding to bits [31:30] of the address that is output from the bus master unit.
- Select the 4-bit value of the SYS_AOF register corresponding to the upper two bits (bits [31:30]) of the 32-bit address that is output from the bus master unit.
- In the selected 4-bit value, use the lower two bits to overwrite bits [31:30] of the original address that was output from the bus master unit, and add the upper two bits as bits [33:32] to the original address.

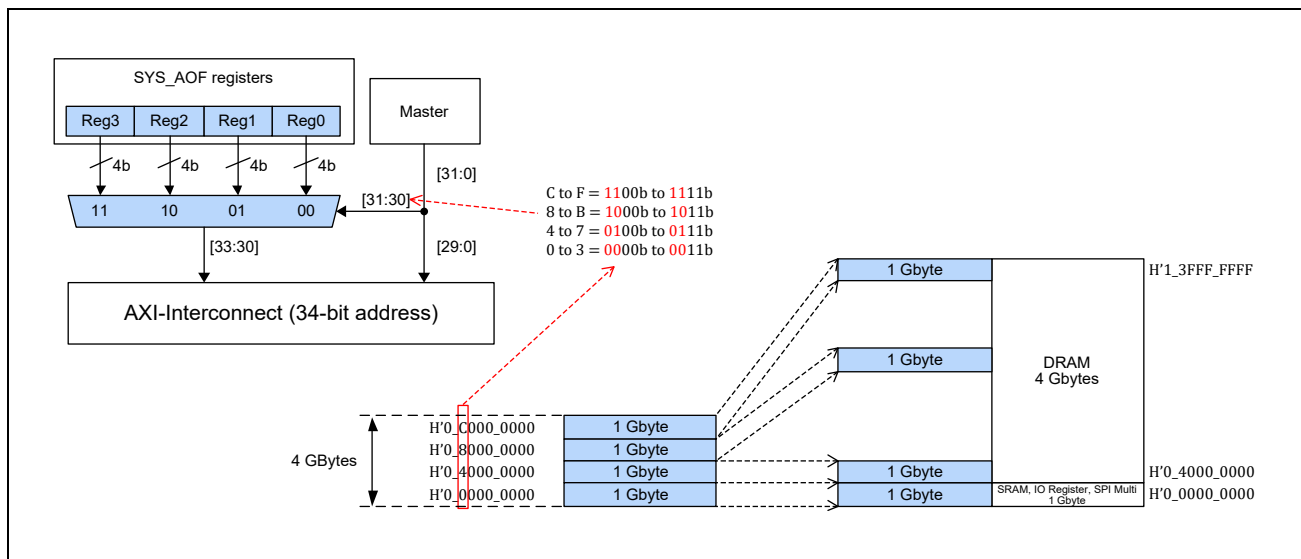

Figure 5.4 Address Space Extension (Overview)

CAUTION

When accessing DRAM from these bus master units, accesses that exceed a 4-Gbyte boundary are prohibited.

5.4.3 Bus Error Interrupt Generation

This LSI generates a bus error interrupt when any of the following conditions is met.

- A bus error is generated when access is disabled by the security setting.
- A bus error is generated when access to a slave unit in the module stop state (MSTOP) is attempted.
- A bus error is generated by a slave unit.

This function is supported for all bus master units included in this LSI.

Bus error interrupts are controlled (retained, cleared, and gathered into a single signal) by the interrupt synchronization circuits (IAX45). For details, including the types of the bus errors, see **Section 8, Interrupt Controller**.

NOTE

This function cannot distinguish between a bus error generated when access is disabled by the security setting and a bus error generated due to other causes.

6. System Controller (SYSC)

6.1 Overview

6.1.1 Features

SYSC is a unit that performs system control of this LSI and has the following functions.

- Product information, external terminal state capture function
 - Management of product information of this LSI, and external terminal status

- 34-bit address space access function (see **Section 5.4.2.1, 34-Bit Address Space Access** for details)
 - If the bus master address is 32bit, do a 2bit extension to access the 34bit address space

- Low power consumption control (see **Section 42, Low Power Mode** for details)
 - Control the transition of this LSI to each mode of low power consumption
 - Setting cancellation conditions and confirming factors at the time of cancellation

- WDT stop control
 - Control WDT stop from Debug Module
 - Stop control of specified channel of WDT from CPU

6.1.2 Block Diagram of SYSC

The block diagram of SYSC is shown in **Figure 6.1**.

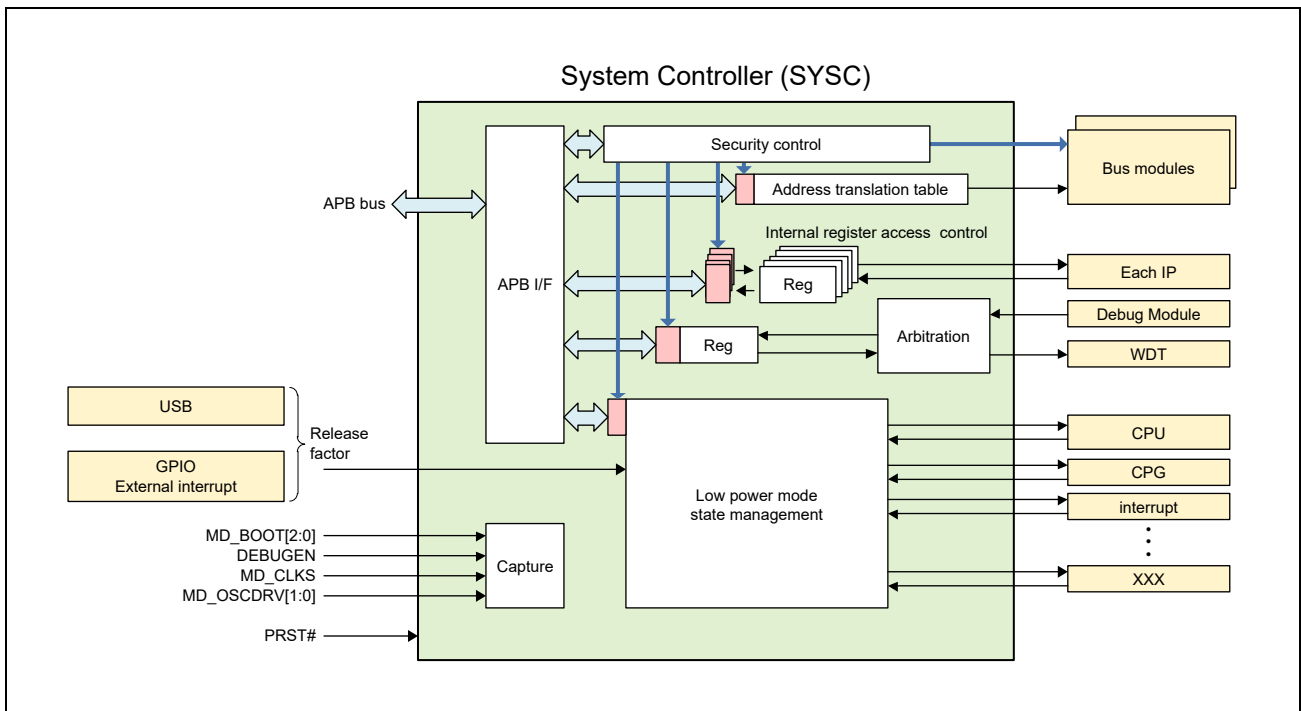

Figure 6.1 SYSC Block Diagram

6.2 Register Configuration

Table 6.1 shows the register configuration of SYSC. The address of the SYSC register is represented by the offset address from the base address. SYSC base address is as follows:

SYSC base address: H'0_1102_0000 (Overall Address Space)

Table 6.1 SYSC Register Configuration (1/2)

Register Name	Abbreviation	R/W	Initial Value	Offset Address	Access Size
Master Access Control Register0	SYS_MSTACCCTL0	R/W	H'00AA_AA00	H'0000	32
Master Access Control Register1	SYS_MSTACCCTL1	R/W	H'AAAA_AAAA	H'0004	32
Master Access Control Register2	SYS_MSTACCCTL2	R/W	H'00AA_AAAA	H'0008	32
Slave Access Control Register0	SYS_SLVACCCTL0	R/W	H'0AAA_AAA0	H'0100	32
Slave Access Control Register1	SYS_SLVACCCTL1	R/W	H'0800_C0AA	H'0104	32
Slave Access Control Register2	SYS_SLVACCCTL2	R/W	H'0000_0002	H'0108	32
Slave Access Control Register3	SYS_SLVACCCTL3	R/W	H'0000_0000	H'010C	32
Slave Access Control Register4	SYS_SLVACCCTL4	R/W	H'0000_0000	H'0110	32
Slave Access Control Register5	SYS_SLVACCCTL5	R/W	H'0000_0000	H'0114	32
Slave Access Control Register6	SYS_SLVACCCTL6	R/W	H'0000_0000	H'0114	32
Slave Access Control Register7	SYS_SLVACCCTL7	R/W	H'0000_0000	H'011C	32
Slave Access Control Register8	SYS_SLVACCCTL8	R/W	H'0000_0000	H'0120	32
Slave Access Control Register10	SYS_SLVACCCTL10	R/W	H'0000_0000	H'0128	32
Slave Access Control Register12	SYS_SLVACCCTL12	R/W	H'0000_0000	H'0130	32
Slave Access Control Register13	SYS_SLVACCCTL13	R/W	H'0000_0000	H'0134	32
Slave Access Control Register14	SYS_SLVACCCTL14	R/W	H'0000_0000	H'0138	32
ECCRAM0 ECC Setting Register	SYS_RAM0_ECC	R/W	H'0000_0000	H'0200	32
ECCRAM0 Access Control Register	SYS_RAM0_EN	R/W	H'0000_0003	H'0204	32
ECCRAM1 ECC Setting Register	SYS_RAM1_ECC	R/W	H'0000_0000	H'0210	32
ECCRAM1 Access Control Register	SYS_RAM1_EN	R/W	H'0000_0003	H'0214	32
WDT0 Control Register	SYS_WDT0_CTRL	R/W	H'0001_0000	H'0220	32
GEther0 Config Register	SYS_GETH0_CFG	R	H'0000_0000	H'0330	32
GEther1 Config Register	SYS_GETH1_CFG	R	H'0000_0000	H'0340	32
I2C0 Config Register	SYS_I2C0_CFG	R/W	H'0000_0000	H'0400	32
I2C1 Config Register	SYS_I2C1_CFG	R/W	H'0000_0000	H'0410	32
I2C2 Config Register	SYS_I2C2_CFG	R/W	H'0000_0000	H'0420	32
I2C3 Config Register	SYS_I2C3_CFG	R/W	H'0000_0000	H'0430	32
AX45MP Core0 Reset Vector Address Low Configuration Register	SYS_AX45MP_CFG_RVAL0	R/W	H'0000_0000	H'0880	32
AX45MP Core0 Reset Vector Address High Configuration Register	SYS_AX45MP_CFG_RVAH0	R/W	H'0000_0000	H'0884	32
AX45MP status Register	SYS_AX45MP_STATUS	R	H'0000_0000	H'088C	32
LSI Mode Signal Register	SYS_LSI_MODE	R	H'000x_xx0x	H'0A00	32
LSI Device ID Register	SYS_LSI_DEVID	R	H'x847_C447	H'0A04	32
LSI Product Register	SYS_LSI_PRR	R	H'0000_0xxx	H'0A08	32
Address Offset Register0	SYS_AOF0	R/W	H'3210_3210	H'0C00	32
Address Offset Register1	SYS_AOF1	R/W	H'3210_3210	H'0C04	32
Address Offset Register2	SYS_AOF2	R/W	H'3210_3210	H'0C08	32
Address Offset Register3	SYS_AOF3	R/W	H'0000_3210	H'0C0C	32

Table 6.1 SYSC Register Configuration (2/2)

Register Name	Abbreviation	R/W	Initial Value	Offset Address	Access Size
Address Offset Register6	SYS_AOF6	R/W	H'3210_3210	H'0C18	32
General Register0	SYS_GPREG_0	R/W	H'0000_0000	H'0E00	32
General Register1	SYS_GPREG_1	R/W	H'0000_0000	H'0E04	32
General Register2	SYS_GPREG_2	R/W	H'0000_0000	H'0E08	32
General Register3	SYS_GPREG_3	R/W	H'0000_0000	H'0E0C	32

6.3 Register Descriptions

6.3.1 Master Access Control Register 0 (SYS_MSTACCCTL0)

This register sets the secure attribute and privilege attribute of transactions from DMAC.

Bit	31	30	29	28	27	26	25	24	23	22	21	20	19	18	17	16
	—	—	—	—	—	—	—	—	—	—	—	—	—	—	—	—
Initial Value	0	0	0	0	0	0	0	0	1	0	1	0	1	0	1	0
R/W	R	R	R	R	R	R	R	R	R	R	R	R	R	R	R	R
Bit	15	14	13	12	11	10	9	8	7	6	5	4	3	2	1	0
	DMAC1_ARSEL	—	DMAC1_ARNS	DMAC1_ARRU	DMAC1_AWSEL	—	DMAC1_AWNS	DMAC1_AWPU	DMAC0_ARSEL	—	DMAC0_ARNS	DMAC0_ARRU	DMAC0_AWSEL	—	DMAC0_AWNS	DMAC0_AWPU
Initial Value	1	0	1	0	1	0	1	0	0	0	0	0	0	0	0	0
R/W	R	R	R	R	R	R	R	R	R/W	R	R/W	R/W	R/W	R	R/W	R/W

Bit	Bit Name	Initial Value	R/W	Description
31 to 24	—	H'00	R	Reserved Whenever it is read, 0 is read. The written value will be ignored.
23	—	1	R	Reserved When read, the initial value is read. When writing, be sure to write the initial value. Operation is not guaranteed if a value other than the initial value is written.
22	—	0	R	Reserved Whenever it is read, 0 is read. The written value will be ignored.
21 to 19	—	101	R	Reserved When read, the initial value is read. When writing, be sure to write the initial value. Operation is not guaranteed if a value other than the initial value is written.
18	—	0	R	Reserved Whenever it is read, 0 is read. The written value will be ignored.
17, 16	—	10	R	Reserved When read, the initial value is read. When writing, be sure to write the initial value. Operation is not guaranteed if a value other than the initial value is written.
15	DMAC1_ARSEL	1	R	Non-Secure DMAC read access secure attribute source selection The value of this register is always 1. The read value is always 1. For access from Non-Secure DMAC, ARPROT [1: 0] is always 10b.
14	—	0	R	Reserved Whenever it is read, 0 is read. The written value will be ignored.
13	DMAC1_ARNS	1	R	Non-Secure DMAC read access secure attribute 1: Non- Secure The value of this bit is always 1. The written value is ignored.
12	DMAC1_ARPU	0	R	Non-Secure DMAC read access privilege attribute 0: Non-privileged access The value of this bit is always 0. The written value is ignored.
11	DMAC1_AWSEL	1	R	Non-Secure DMAC write access security attribute source selection The value of this register is always 1. The read value is always 1 For access from Non-Secure DMAC, AWPROT [1: 0] is always 10b.
10	—	0	R	Reserved Whenever it is read, 0 is read. The written value will be ignored.

Bit	Bit Name	Initial Value	R/W	Description
9	DMAC1_AWNS	1	R	Non-Secure DMAC write access secure attribute 1: Non-Secure The value of this bit is always 1. The written value is ignored.
8	DMAC1_AWPU	0	R	Non-Secure DMAC write access privilege attribute 0: Non-privileged access The value of this bit is always 0. The written value is ignored.
7	DMAC0_ARSEL	0	R/W	Secure DMAC read access security attribute source selection*1 0: ARPROT[1: 0] selects the value from Secure DMAC 1: DMAC0_ARPU is selected for ARPROT [0], and DMAC0_ARNS is selected for ARPROT [1].
6	—	0	R	Reserved Whenever it is read, 0 is read. The written value will be ignored.
5	DMAC0_ARNS	0	R/W	Secure DMAC read access secure attribute*1 0: Secure 1: Non-secure
4	DMAC0_ARPU	0	R/W	Secure DMAC read access privilege attribute*1 0: Non-privileged access 1: Privileged access
3	DMAC0_AWSEL	0	R/W	Secure DMAC write access security attribute source selection*1 0: AWPROT[1: 0] selects the value from Secure DMAC 1: DMAC0_AWPU is selected for AWPROT [0], and DMAC0_AWNS is selected for AWPROT [1].
2	—	0	R	Reserved Whenever it is read, 0 is read. The written value will be ignored.
1	DMAC0_AWNS	0	R/W	Secure DMAC write access secure attribute*1 0: Secure 1: Non-secure
0	DMAC0_AWPU	0	R/W	Secure DMAC write access privilege attribute*1 0: Non-privileged access 1: Privileged access

Note 1. This register setting is prohibited changing the setting while the target master is operating. Change it before the master initiates access.

6.3.2 Master Access Control Register 1 (SYS_MSTACCCTL1)

This register sets the secure attribute and privilege attribute of transactions from GbEthernet and SDHI/eMMC.

Bit	31	30	29	28	27	26	25	24	23	22	21	20	19	18	17	16
	GEther1_ARSEL	—	GEther1_ARNS	GEther1_ARRU	GEther1_AWSEL	—	GEther1_AWNS	GEther1_AWPU	GEther0_ARSEL	—	GEther0_ARNS	GEther0_ARRU	GEther0_AWSEL	—	GEther0_AWNS	GEther0_AWPU
Initial Value	1	0	1	0	1	0	1	0	1	0	1	0	1	0	1	0
R/W	R/W	R	R/W	R/W	R/W	R	R/W	R/W	R/W	R	R/W	R/W	R/W	R	R/W	R/W

Bit	15	14	13	12	11	10	9	8	7	6	5	4	3	2	1	0
	SDHI1_ARSEL	—	SDHI1_ARNS	SDHI1_ARRU	SDHI1_AWSEL	—	SDHI1_AWNS	SDHI1_AWPU	SDHI0_ARSEL	—	SDHI0_ARNS	SDHI0_ARRU	SDHI0_AWSEL	—	SDHI0_AWNS	SDHI0_AWPU
Initial Value	1	0	1	0	1	0	1	0	1	0	1	0	1	0	1	0
R/W	R/W	R	R/W	R/W	R/W	R	R/W	R/W	R/W	R	R/W	R/W	R/W	R	R/W	R/W

Bit	Bit Name	Initial Value	R/W	Description
31	GEther1_ARSEL	1	R/W	GbEthernet (channel 1) read access security attribute source selection* ¹ 0: ARPROT[1:0] is always 10b 1: GEther1_ARPU is selected for ARPROT [0], and GEther1_ARNS is selected for ARPROT[1].
30	—	0	R	Reserved Whenever it is read, 0 is read. The written value will be ignored.
29	GEther1_ARNS	1	R/W	GbEthernet (channel 1) read access secure attribute* ¹ 0: Secure 1: Non-secure
28	GEther1_ARPU	0	R/W	GbEthernet (channel 1) read access privilege attribute* ¹ 0: Non-privileged access 1: Privileged access
27	GEther1_AWSEL	1	R/W	GbEthernet (channel 1) write access security attribute source selection* ¹ 0: AWPROT[1:0] is always 10b 1: GEther1_AWPU is selected for AWPROT [0], and GEther1_AWNS is selected for AWPROT[1].
26	—	0	R	Reserved Whenever it is read, 0 is read. The written value will be ignored.
25	GEther1_AWNS	1	R/W	GbEthernet (channel 1) write access secure attribute* ¹ 0: Secure 1: Non-secure
24	GEther1_AWPU	0	R/W	GbEthernet (channel 1) write access privilege attribute* ¹ 0: Non-privileged access 1: Privileged access
23	GEther0_ARSEL	1	R/W	GbEthernet (channel 0) read access security attribute source selection* ¹ 0: ARPROT[1:0] is always 10b 1: GEther0_ARPU is selected for ARPROT [0], and GEther0_ARNS is selected for ARPROT[1].
22	—	0	R	Reserved Whenever it is read, 0 is read. The written value will be ignored.
21	GEther0_ARNS	1	R/W	GbEthernet (channel 0) read access secure attribute* ¹ 0: Secure 1: Non-secure
20	GEther0_ARPU	0	R/W	GbEthernet (channel 0) read access privilege attribute* ¹ 0: Non-privileged access 1: Privileged access

Bit	Bit Name	Initial Value	R/W	Description
19	GEther0_AWSEL	1	R/W	GbEthernet (channel 0) write access security attribute source selection* ¹ 0: AWPROT[1:0] is always 10b 1: GEther0_AWPU is selected for AWPROT [0], and GEther0_AWNS is selected for AWPROT [1].
18	—	0	R	Reserved Whenever it is read, 0 is read. The written value will be ignored.
17	GEther0_AWNS	1	R/W	GbEthernet (channel 0) write access secure attribute* ¹ 0: Secure 1: Non-secure
16	GEther0_AWPU	0	R/W	GbEthernet (channel 0) write access privilege attribute* ¹ 0: Non-privileged access 1: Privileged access
15	SDHI1_ARSEL	1	R/W	SDHI (channel 1) read access security attributed source selection* ¹ 0: ARPROT[1:0] is always 10b 1: SDHI1_ARPU is selected for ARPROT [0], and SDHI1_ARNS is selected for ARPROT [1].
14	—	0	R	Reserved Whenever it is read, 0 is read. The written value will be ignored.
13	SDHI1_ARNS	1	R/W	SDHI (channel 1) read access secure attribute* ¹ 0: Secure 1: Non-secure
12	SDHI1_ARPU	0	R/W	SDHI (channel 1) read access privilege attribute* ¹ 0: Non-privileged access 1: Privileged access
11	SDHI1_AWSEL	1	R/W	SDHI (channel 1) write access security attribute source selection* ¹ 0: AWPROT[1:0] is always 10b 1: SDHI1_AWPU is selected for AWPROT [0], and SDHI1_AWNS is selected for AWPROT [1].
10	—	0	R	Reserved Whenever it is read, 0 is read. The written value will be ignored.
9	SDHI1_AWNS	1	R/W	SDHI (channel 1) write access secure attribute* ¹ 0: Secure 1: Non-secure
8	SDHI1_AWPU	0	R/W	SDHI (channel 1) write access privilege attribute* ¹ 0: Non-privileged access 1: Privileged access
7	SDHI0_ARSEL	1	R/W	SDHI/eMMC (channel 0) read access security attributed source selection * ¹ 0: ARPROT[1:0] is always 10b 1: SDHI0_ARPU is selected for ARPROT [0], and SDHI0_ARNS is selected for ARPROT [1].
6	—	0	R	Reserved Whenever it is read, 0 is read. The written value will be ignored.
5	SDHI0_ARNS	1	R/W	SDHI/eMMC (channel 0) read access secure attribute* ¹ 0: Secure 1: Non-secure
4	SDHI0_ARPU	0	R/W	SDHI/eMMC (channel 0) read access privilege attribute* ¹ 0: Non-privileged access 1: Privileged access
3	SDHI0_AWSEL	1	R/W	SDHI/eMMC (channel 0) write access security attribute source selection* ¹ 0: AWPROT[1:0] is always 10b 1: SDHI0_AWPU is selected for AWPROT [0], and SDHI0_AWNS is selected for AWPROT [1].

Bit	Bit Name	Initial Value	R/W	Description
2	—	0	R	Reserved Whenever it is read, 0 is read. The written value will be ignored.
1	SDHI0_AWNS	1	R/W	SDHI/eMMC (channel 0) write access secure attribute*1 0: Secure 1: Non-secure
0	SDHI0_AWPU	0	R/W	SDHI/eMMC (channel 0) write access privilege attribute*1 0: Non-privileged access 1: Privileged access

Note 1. This register setting is prohibited changing the setting while the target master is operating. Change it before the master initiates access.

6.3.3 Master Access Control Register 2 (SYS_MSTACCCTL2)

This register sets the secure attribute and privilege attribute of transactions from USB2.0.

Bit	31	30	29	28	27	26	25	24	23	22	21	20	19	18	17	16
	—	—	—	—	—	—	—	—	USB2_0 D_ARSEL	—	USB2_0 D_ARNS	USB2_0 D_ARPU	USB2_0 D_AWSEL	—	USB2_0 D_AWNS	USB2_0 D_AWPU
Initial Value	0	0	0	0	0	0	0	0	1	0	1	0	1	0	1	0
R/W	R	R	R	R	R	R	R	R	R/W	R	R/W	R/W	R/W	R	R/W	R/W
Bit	15	14	13	12	11	10	9	8	7	6	5	4	3	2	1	0
	USB2_1 H_ARSEL	—	USB2_1 H_ARNS	USB2_1 H_ARPU	USB2_1 H_AWSEL	—	USB2_1 H_AWNS	USB2_1 H_AWPU	USB2_0 H_ARSEL	—	USB2_0 H_ARNS	USB2_0 H_ARPU	USB2_0 H_AWSEL	—	USB2_0 H_AWNS	USB2_0 H_AWPU
Initial Value	1	0	1	0	1	0	1	0	1	0	1	0	1	0	1	0
R/W	R/W	R	R/W	R/W	R/W	R	R/W	R/W	R/W	R	R/W	R/W	R/W	R	R/W	R/W

Bit	Bit Name	Initial Value	R/W	Description
31 to 24	—	H'00	R	Reserved Whenever it is read, 0 is read. The written value will be ignored.
23	USB2_0D_ARSEL	1	R/W	USB2.0 (channel 0, function) read access security attribute source selection*1 0: ARPROT[0] selects the HPROT[1] value from USB2.0 channel 0 Function, and ARPROT[1] is always 1. 1: USB2_0D_ARPU is selected for ARPROT[0], and USB2_0D_ARNS is selected for ARPROT[1].
22	—	0	R	Reserved Whenever it is read, 0 is read. The written value will be ignored.
21	USB2_0D_ARNS	1	R/W	USB2.0 (channel 0, function) read access secure attribute*1 0: Secure 1: Non-secure
20	USB2_0D_ARPU	0	R/W	USB2.0 (channel 0, function) read access privilege attribute*1 0: Non-privileged access 1: Privileged access
19	USB2_0D_AWSEL	1	R/W	USB2.0 (channel 0, function) write access security attribute source selection*1 0: AWPROT[0] selects the HPROT[1] value from USB2.0 channel 0 Function, and AWPROT [1] is always 1 1: USB2_0D_AWPU is selected for AWPROT[0], and USB2_0D_AWNS is selected for AWPROT[1].
18	—	0	R	Reserved Whenever it is read, 0 is read. The written value will be ignored.
17	USB2_0D_AWNS	1	R/W	USB2.0 (channel 0, function) write access secure attribute*1 0: Secure 1: Non-secure
16	USB2_0D_AWPU	0	R/W	USB2.0 (channel 0, function) write access privilege attribute*1 0: Non-privileged access 1: Privileged access
15	USB2_1H_ARSEL	0	R/W	USB2.0 (channel 1, host) read access security attribute source selection*1 0: ARPROT[0] selects the HPROT[1] value from USB2.0 channel 1 Host, and ARPROT[1] is always 1. 1: USB2_1H_ARPU is selected for ARPROT[0], and USB2_1H_ARNS is selected for ARPROT[1].
14	—	0	R	Reserved Whenever it is read, 0 is read. The written value will be ignored.

Bit	Bit Name	Initial Value	R/W	Description
13	USB2_1H_ARNS	1	R/W	USB2.0 (channel 1, host) read access secure attribute*1 0: Secure 1: Non-secure
12	USB2_1H_ARPU	0	R/W	USB2.0 (channel 1, host) read access privilege attribute*1 0: Non-privileged access 1: Privileged access
11	USB2_1H_AWSEL	1	R/W	USB2.0 (channel 1, host) write access security attribute source selection*1 0: AWPROT[0] selects the HPROT[1] value from USB2.0 channel 1 Host, and AWPROT[1] is always 1. 1: USB2_1H_AWPU is selected for AWPROT[0], and USB2_1H_AWNS is selected for AWPROT[1].
10	—	0	R	Reserved Whenever it is read, 0 is read. The written value will be ignored.
9	USB2_1H_AWNS	1	R/W	USB2.0 (channel 1, host) write access secure attribute*1 0: Secure 1: Non-secure
8	USB2_1H_AWPU	0	R/W	USB2.0 (channel 1, host) write access privilege attribute*1 0: Non-privileged access 1: Privileged access
7	USB2_0H_ARSEL	0	R/W	USB2.0 (channel 0, host) read access security attribute source selection*1 0: ARPROT[0] selects the HPROT[1] value from USB2.0 channel 0 Host, and ARPROT[1] is always 1 1: USB2_0H_ARPU is selected for ARPROT[0], and USB2_0H_ARNS is selected for ARPROT[1].
6	—	0	R	Reserved Whenever it is read, 0 is read. The written value will be ignored.
5	USB2_0H_ARNS	1	R/W	USB2.0 (channel 0, host) read access secure attribute*1 0: Secure 1: Non-secure
4	USB2_0H_ARPU	0	R/W	USB2.0 (channel 0, host) read access privilege attribute*1 0: Non-privileged access 1: Privileged access
3	USB2_0H_AWSEL	1	R/W	USB2.0 (channel 0, host) write access security attribute source selection*1 0: AWPROT[1] selects the HPROT[1] value from USB2.0 channel 0 Host, and AWPROT[0] is always 1. 1: USB2_0H_AWPU is selected for AWPROT[0], and USB2_0H_AWNS is selected for AWPROT[1].
2	—	0	R	Reserved Whenever it is read, 0 is read. The written value will be ignored.
1	USB2_0H_AWNS	1	R/W	USB2.0 (channel 0, host) write access secure attribute*1 0: Secure 1: Non-secure
0	USB2_0H_AWPU	0	R/W	USB2.0 (channel 0, host) write access privilege attribute*1 0: Non-privileged access 1: Privileged access

Note 1. This register setting is prohibited changing the setting while the target master is operating. Change it before the master initiates access.

6.3.4 Slave Access Control Register 0 (SYS_SLVACCCTL0)

This register sets the security levels for determining whether to enable or disable access to each set of registers in the SRAM ACPU (Reg) and SRAM MCPU (Reg).

Bit	31	30	29	28	27	26	25	24	23	22	21	20	19	18	17	16
	—	—	—	—	—	—	—	—	—	—	—	—	—	—	—	—
Initial Value	0	0	0	0	1	0	1	0	1	0	1	0	1	0	1	0
R/W	R	R	R	R	R	R	R	R	R	R	R	R	R	R	R	R
Bit	15	14	13	12	11	10	9	8	7	6	5	4	3	2	1	0
	—	—	—	—	—	—	—	—	—	—	—	—	SRAM1_SL[1:0]		SRAM0_SL[1:0]	
Initial Value	1	0	1	0	1	0	1	0	1	0	1	0	0	0	0	0
R/W	R	R	R	R	R	R	R	R	R	R	R	R	R/W	R/W	R/W	R/W

Bit	Bit Name	Initial Value	R/W	Description
31 to 4	—	H'0AAAA AA	R	Reserved When read, the initial value is read. When writing, be sure to write the initial value. Operation is not guaranteed if a value other than the initial value is written.
3, 2	SRAM1_SL [1:0]	00b	R/W	SRAM MCPU <Reg> slave access permission control Set the security level SL [1:0] for the slave SRAM MCPU <Reg>.
1, 0	SRAM0_SL [1:0]	00b	R/W	SRAM ACPU <Reg> slave access permission control Set the security level SL [1:0] for the slave SRAM ACPU <Reg>.

6.3.5 Slave Access Control Register 1 (SYS_SLVACCCTL1)

This register sets the security levels for determining whether to enable or disable access to each set of registers in the DMAC, GPIO, IAX45, PLIC, Machine Timer, SYSC, CPG, Debug Module and TZC.

Bit	31	30	29	28	27	26	25	24	23	22	21	20	19	18	17	16
	—	—	DMAC1_SL		DMAC0_SL		—	—	GPIO_SL		IAX45_SL		PLIC_SL		MT_SL	
Initial Value	0	0	0	0	1	0	0	0	0	0	0	0	0	0	0	0
R/W	R	R	R	R	R/W	R/W	R	R	R/W	R/W	R/W	R/W	R/W	R/W	R/W	R/W
Bit	15	14	13	12	11	10	9	8	7	6	5	4	3	2	1	0
	SYSC_SL		CPG_SL		DM_SL		—	—	TZC3_SL		TZC2_SL		TZC1_SL		TZC0_SL	
Initial Value	1	1	0	0	0	0	0	0	1	0	1	0	1	0	1	0
R/W	R	R	R/W	R/W	R/W	R/W	R	R	R/W	R/W	R/W	R/W	R/W	R/W	R/W	R/W

Bit	Bit Name	Initial Value	R/W	Description
31, 30	—	00b	R	Reserved Whenever it is read, 0 is read. The written value will be ignored.
29, 28	DMAC1_SL [1:0]	00b	R/W	Non-Secure DNAC slave access permission control Set the security level SL [1:0] for the slave Non-Secure DMAC.
27, 26	DMAC0_SL [1:0]	10b	R/W	Secure DMAC slave access permission control Set the security level SL [1:0] for the slave Secure DMAC.
25, 24	—	00b	R	Reserved When read, the initial value is read. When writing, be sure to write the initial value. Operation is not guaranteed if a value other than the initial value is written.
23, 22	GPIO_SL[1:0]	00b	R/W	GPIO slave access permission control Set the security level SL [1:0] for the slave GPIO.
21, 20	IAX45_SL[1:0]	00b	R/W	IAX45 slave access permission control Set the security level SL [1:0] for the slave IAX45.
19, 18	PLIC_SL[1:0]	00b	R/W	PLIC slave access permission control Set the security level SL [1:0] for the slave PLIC.
17, 16	MT_SL[1:0]	00b	R/W	Machine Timer slave access permission control Set the security level SL [1:0] for the slave Machine Timer.
15, 14	SYSC_SL[1:0]	11b	R	SYSC slave access permission control Reading the bits always returns 11b. Value cannot be written to these bits.
13, 12	CPG_SL[1:0]	00b	R/W	CPG slave access permission control Set the security level SL [1:0] for the slave CPG.
11, 10	DM_SL[1:0]	00b	R/W	Debug Module slave access permission control Set the security level SL [1:0] for the slave Debug Module.
9, 8	—	00b	R	Reserved Whenever it is read, 0 is read. The written value will be ignored.
7, 6	TZC3_SL[1:0]	10b	R/W	TZC (DDR) <Reg> slave access permission control Set the security level SL [1:0] for the slave TZC (DDR) <Reg>. These bits can only be set to 10b or 11b. Setting them to 00b or 01b is prohibited. Operation is not guaranteed when 00b or 01b is set.
5, 4	TZC2_SL[1:0]	10b	R/W	SPI Multi I/O controller slave access permission control Set the security level SL [1:0] for the slave TZC (SPI Multi I/O) <Reg>. These bits can only be set to 10b or 11b. Setting them to 00b or 01b is prohibited. Operation is not guaranteed when 00b or 01b is set.

Bit	Bit Name	Initial Value	R/W	Description
3, 2	TZC1_SL[1:0]	10b	R/W	TZC (SRAM MCPU) <Reg> slave access permission control Set the security level SL [1:0] for the slave TZC (SRAM MCPU) <Reg>. These bits can only be set to 10b or 11b. Setting them to 00b or 01b is prohibited. Operation is not guaranteed when 00b or 01b is set.
1, 0	TZC0_SL[1:0]	10b	R/W	TZC (SRAM ACPU) <Reg> slave access permission control Set the security level SL [1:0] for the slave TZC (SRAM ACPU) <Reg>. These bits can only be set to 10b or 11b. Setting them to 00b or 01b is prohibited. Operation is not guaranteed when 00b or 01b is set.

6.3.6 Slave Access Control Register 2 (SYS_SLVACCCTL2)

This register sets the security levels for determining whether to enable or disable access to each set of registers in the GTM, WDT, MTU3a, POE3, and DDR.

Bit	31	30	29	28	27	26	25	24	23	22	21	20	19	18	17	16
	—	—	—	—	—	—	—	—	DDR_SL		—	—	—	—	POE3_SL	
Initial Value	0	0	0	0	0	0	0	0	0	0	0	0	0	0	0	0
R/W	R	R	R	R	R	R	R	R	R/W	R/W	R	R	R	R	R/W	R/W
Bit	15	14	13	12	11	10	9	8	7	6	5	4	3	2	1	0
	MTU3A_SL		—	—	—	—	—	—	WDT0_SL		OSTM2_SL		OSTM1_SL		OSTM0_SL	
Initial Value	0	0	0	0	0	0	0	0	0	0	0	0	0	0	1	0
R/W	R/W	R/W	R	R	R	R	R	R	R/W	R/W	R/W	R/W	R/W	R/W	R/W	R/W

Bit	Bit Name	Initial Value	R/W	Description
31 to 24	—	H'00	R	Reserved Whenever it is read, 0 is read. The written value will be ignored.
23, 22	DDR_SL	00b	R/W	DDR <Reg> slave access permission control Set the security level SL [1:0] for the slave DDR <Reg>.
21, 20	—	00b	R	Reserved When read, the initial value is read. When writing, be sure to write the initial value. Operation is not guaranteed if a value other than the initial value is written.
19, 18	—	00b	R	Reserved When read, the initial value is read. When writing, be sure to write the initial value. Operation is not guaranteed if a value other than the initial value is written.
17, 16	POE3_SL	00b	R/W	POE3 slave access permission control Set the security level SL [1:0] for the slave POE3.
15, 14	MTU3A_SL	00b	R/W	MTU3a slave access permission control Set the security level SL [1:0] for the slave MTU3a.
13, 12	—	00b	R	Reserved When read, the initial value is read. When writing, be sure to write the initial value. Operation is not guaranteed if a value other than the initial value is written.
11, 10	—	00b	R	Reserved When read, the initial value is read. When writing, be sure to write the initial value. Operation is not guaranteed if a value other than the initial value is written.
9, 8	—	00b	R	Reserved When read, the initial value is read. When writing, be sure to write the initial value. Operation is not guaranteed if a value other than the initial value is written.
7, 6	WDT0_SL	00b	R/W	WDT channel 0 slave access permission control Set the security level SL [1:0] for the slave WDT channel 0.
5, 4	OSTM2_SL	00b	R/W	GTM channel 2 slave access permission control Set the security level SL [1:0] for the slave GTM channel 2.
3, 2	OSTM1_SL	00b	R/W	GTM channel 1 slave access permission control Set the security level SL [1:0] for the slave GTM channel 1.
1, 0	OSTM0_SL	10b	R/W	GTM channel 0 slave access permission control Set the security level SL [1:0] for the slave GTM channel 0.

6.3.7 Slave Access Control Register 3 (SYS_SLVACCCTL3)

This register sets the security levels for determining whether to enable or disable access to each set of registers in the USB2.0, SDHI/eMMC and GbEthernet.

Bit	31	30	29	28	27	26	25	24	23	22	21	20	19	18	17	16
	—	—	ETH1_SL		ETH0_SL		SDHI1_SL		SDHI0_SL		USB21_SL		USB20_SL		USBT_SL	
Initial Value	0	0	0	0	0	0	0	0	0	0	0	0	0	0	0	0
R/W	R	R	R/W	R/W	R/W	R/W	R/W	R/W	R/W	R/W	R/W	R/W	R/W	R/W	R/W	R/W
Bit	15	14	13	12	11	10	9	8	7	6	5	4	3	2	1	0
	—	—	—	—	—	—	—	—	—	—	—	—	—	—	—	—
Initial Value	0	0	0	0	0	0	0	0	0	0	0	0	0	0	0	0
R/W	R	R	R	R	R	R	R	R	R	R	R	R	R	R	R	R

Bit	Bit Name	Initial Value	R/W	Description
31, 30	—	00b	R	Reserved Whenever it is read, 0 is read. The written value will be ignored.
29, 28	ETH1_SL	00b	R/W	GbEthernet channel1 slave access permission control Set the security level SL [1:0] for the slave GbEthernet channel 1.
27, 26	ETH0_SL	00b	R/W	GbEthernet channel 0 slave access permission control Set the security level SL [1:0] for the slave GbEthernet channel 0.
25, 24	SDHI1_SL	00b	R/W	SDHI channel 1 slave access permission control Set the security level SL [1:0] for the slave SDHI channel 1.
23, 22	SDHI0_SL	00b	R/W	SDHI/eMMC channel 0 slave access permission control Set the security level SL [1:0] for the slave SDHI/eMMC channel 0.
21, 20	USB21_SL	00b	R/W	USB2.0 channel 1 slave access permission control Set the security level SL [1:0] for the slave USB2.0 channel 1.
19, 18	USB20_SL	00b	R/W	USB2.0 channel 0 slave access permission control Set the security level SL [1:0] for the slave USB2.0 channel 0. USB 2.0 channel 0 has a common security level for Host and Function.
17, 16	USBT_SL	00b	R/W	USBPHY Control slave access permission control Set the security level SL [1:0] for the slave USBPHY Control.
15, 14	—	00b	R	Reserved When read, the initial value is read. When writing, be sure to write the initial value. Operation is not guaranteed if a value other than the initial value is written.
13, 12	—	00b	R	Reserved When read, the initial value is read. When writing, be sure to write the initial value. Operation is not guaranteed if a value other than the initial value is written.
11, 10	—	00b	R	Reserved When read, the initial value is read. When writing, be sure to write the initial value. Operation is not guaranteed if a value other than the initial value is written.
9, 8	—	00b	R	Reserved When read, the initial value is read. When writing, be sure to write the initial value. Operation is not guaranteed if a value other than the initial value is written.
7, 6	—	00b	R	Reserved When read, the initial value is read. When writing, be sure to write the initial value. Operation is not guaranteed if a value other than the initial value is written.
5, 4	—	00b	R	Reserved When read, the initial value is read. When writing, be sure to write the initial value. Operation is not guaranteed if a value other than the initial value is written.

Bit	Bit Name	Initial Value	R/W	Description
3, 2	—	00b	R	Reserved When read, the initial value is read. When writing, be sure to write the initial value. Operation is not guaranteed if a value other than the initial value is written.
1, 0	—	00b	R	Reserved When read, the initial value is read. When writing, be sure to write the initial value. Operation is not guaranteed if a value other than the initial value is written.

6.3.8 Slave Access Control Register 4 (SYS_SLVACCCTL4)

This register sets the security levels for determining whether to enable or disable access to each set of registers in the I2C, CANFD, RSPI, SCIF, SCI, and IrDA.

Bit	31	30	29	28	27	26	25	24	23	22	21	20	19	18	17	16
	IRDA_SL		SCI1_SL		SCIO_SL		SCIF4_SL		SCIF3_SL		SCIF2_SL		SCIF1_SL		SCIF0_SL	
Initial Value	0	0	0	0	0	0	0	0	0	0	0	0	0	0	0	0
R/W	R	R	R/W	R/W	R/W	R/W	R/W	R/W	R/W	R/W	R/W	R/W	R/W	R/W	R/W	R/W
Bit	15	14	13	12	11	10	9	8	7	6	5	4	3	2	1	0
	—				RSPI_SL		CANFD_SL		I2C3_SL		I2C2_SL		I2C1_SL		I2C0_SL	
Initial Value	0	0	0	0	0	0	0	0	0	0	0	0	0	0	0	0
R/W	R	R	R	R	R/W	R/W	R/W	R/W	R/W	R/W	R/W	R/W	R/W	R/W	R/W	R/W

Bit	Bit Name	Initial Value	R/W	Description
31, 30	IRDA_SL	00b	R	SCI channel 0 (IrDA) slave access permission control Set the security level SL [1:0] for the slave SCI channel 0 (IrDA).
29, 28	SCI1_SL	00b	R/W	SCI channel 1 slave access permission control Set the security level SL [1:0] for the slave SCI channel 1.
27, 26	SCIO_SL	00b	R/W	SCI channel 0 slave access permission control Set the security level SL [1:0] for the slave SCI channel 0.
25, 24	SCIF4_SL	00b	R/W	SCIF channel 4 slave access permission control Set the security level SL [1:0] for the slave SCIF channel 4.
23, 22	SCIF3_SL	00b	R/W	SCIF channel 3 slave access permission control Set the security level SL [1:0] for the slave SCIF channel 3.
21, 20	SCIF2_SL	00b	R/W	SCIF channel 2 slave access permission control Set the security level SL [1:0] for the slave SCIF channel 2.
19, 18	SCIF1_SL	00b	R/W	SCIF channel 1 slave access permission control Set the security level SL [1:0] for the slave SCIF channel 1.
17, 16	SCIF0_SL	00b	R/W	SCIF channel 0 slave access permission control Set the security level SL [1:0] for the slave SCIF channel 0.
15 to 12	—	H'0	R	Reserved Whenever it is read, 0 is read. The written value will be ignored.
11, 10	RSPI_SL	00b	R/W	RSPI slave access permission control Set the security level SL [1:0] for the slave RSPI. RSPI has a common security level for channel 0 to channel 2.
9, 8	CANFD_SL	00b	R/W	CANFD slave access permission control Set the security level SL [1:0] for the slave CANFD.
7, 6	I2C3_SL	00b	R/W	I2C channel 3 slave access permission control Set the security level SL [1:0] for the slave I2C channel 3.
5, 4	I2C2_SL	00b	R/W	I2C channel 2 slave access permission control Set the security level SL [1:0] for the slave I2C channel 2.
3, 2	I2C1_SL	00b	R/W	I2C channel 1 slave access permission control Set the security level SL [1:0] for the slave I2C channel 1.
1, 0	I2C0_SL	00b	R/W	I2C channel 0 slave access permission control Set the security level SL [1:0] for the slave I2C channel 0.

6.3.9 Slave Access Control Register 5 (SYS_SLVACCCTL5)

This register sets the security levels for determining whether to enable or disable access to each set of registers in the SSIF.

Bit	31	30	29	28	27	26	25	24	23	22	21	20	19	18	17	16
	—	—	—	—	—	—	—	—	—	—	—	—	—	—	—	—
Initial Value	0	0	0	0	0	0	0	0	0	0	0	0	0	0	0	0
R/W	R	R	R	R	R	R	R	R	R	R	R	R	R	R	R	R
Bit	15	14	13	12	11	10	9	8	7	6	5	4	3	2	1	0
	—	—	—	—	—	—	—	—	—	—	—	—	—	—	SSIF_SL	
Initial Value	0	0	0	0	0	0	0	0	0	0	0	0	0	0	0	0
R/W	R	R	R	R	R	R	R	R	R	R	R	R	R	R	R/W	R/W

Bit	Bit Name	Initial Value	R/W	Description
31 to 6	—	All 0	R	Reserved Whenever it is read, 0 is read. The written value will be ignored.
5, 4	—	00b	R	Reserved When read, the initial value is read. When writing, be sure to write the initial value. Operation is not guaranteed if a value other than the initial value is written.
3, 2	—	00b	R	Reserved Whenever it is read, 0 is read. The written value will be ignored.
1, 0	SSIF_SL	00b	R/W	SSIF slave access permission control Set the security level SL [1:0] for the slave SSIF. SSIF has a common security level for channel 0 to channel 3.

6.3.10 Slave Access Control Register 6 (SYS_SLVACCCTL6)

This register sets the security levels for determining whether to enable or disable access to each set of registers in the ADC and TSU.

Bit	31	30	29	28	27	26	25	24	23	22	21	20	19	18	17	16
	—	—	—	—	—	—	—	—	—	—	—	—	—	—	—	—
Initial Value	0	0	0	0	0	0	0	0	0	0	0	0	0	0	0	0
R/W	R	R	R	R	R	R	R	R	R	R	R	R	R	R	R	R
Bit	15	14	13	12	11	10	9	8	7	6	5	4	3	2	1	0
	—	—	—	—	—	—	—	—	—	—	—	—	TSU_SL		ADC_SL	
Initial Value	0	0	0	0	0	0	0	0	0	0	0	0	0	0	0	0
R/W	R	R	R	R	R	R	R	R	R	R	R	R	R/W	R/W	R/W	R/W

Bit	Bit Name	Initial Value	R/W	Description
31 to 4	—	All 0	R	Reserved Whenever it is read, 0 is read. The written value will be ignored.
3, 2	TSU_SL	00b	R/W	TSU slave access permission control Set the security level SL [1:0] for the slave TSU.
1, 0	ADC_SL	00b	R/W	ADC slave access permission control Set the security level SL [1:0] for the slave ADC.

6.3.11 Slave Access Control Register 7 (SYS_SLVACCCTL7)

This register sets the security levels for determining whether to enable or disable access to each set of registers in the OTP.

Bit	31	30	29	28	27	26	25	24	23	22	21	20	19	18	17	16
	—	—	—	—	—	—	—	—	—	—	—	—	—	—	—	—
Initial Value	0	0	0	0	0	0	0	0	0	0	0	0	0	0	0	0
R/W	R	R	R	R	R	R	R	R	R	R	R	R	R	R	R	R
Bit	15	14	13	12	11	10	9	8	7	6	5	4	3	2	1	0
	—	—	—	—	—	—	—	—	—	—	—	—	OTP_SL		—	—
Initial Value	0	0	0	0	0	0	0	0	0	0	0	0	0	0	0	0
R/W	R	R	R	R	R	R	R	R	R	R	R	R	R/W	R/W	R	R

Bit	Bit Name	Initial Value	R/W	Description
31 to 4	—	All 0	R	Reserved Whenever it is read, 0 is read. The written value will be ignored.
3, 2	OTP_SL	00b	R/W	OTP slave access permission control Set the security level SL [1:0] for the slave OTP.
1, 0	—	00b	R	Reserved When read, the initial value is read. When writing, be sure to write the initial value. Operation is not guaranteed if a value other than the initial value is written.

6.3.12 Slave Access Control Register 8 (SYS_SLVACCCTL8)

This register sets the security levels for determining whether to enable or disable access to each set of registers in the AX45MP control register in SYSC.

Bit	31	30	29	28	27	26	25	24	23	22	21	20	19	18	17	16
	—	—	—	—	—	—	—	—	—	—	—	—	—	—	—	—
Initial Value	0	0	0	0	0	0	0	0	0	0	0	0	0	0	0	0
R/W	R	R	R	R	R	R	R	R	R	R	R	R	R	R	R	R
Bit	15	14	13	12	11	10	9	8	7	6	5	4	3	2	1	0
	—	—	—	—	—	—	—	—	—	—	AX45MP_SL	—	—	—	—	—
Initial Value	0	0	0	0	0	0	0	0	0	0	0	0	0	0	0	0
R/W	R	R	R	R	R	R	R	R	R	R	R/W	R/W	R	R	R	R

Bit	Bit Name	Initial Value	R/W	Description
31 to 6	—	All 0	R	Reserved Whenever it is read, 0 is read. The written value will be ignored.
5, 4	AX45MP_SL	00b	R/W	SYSC <AX45MP Control Reg> slave access permission control Set the security level SL [1:0] for the AX45MP control register in SYSC.
3, 2	—	00b	R	Reserved When read, the initial value is read. When writing, be sure to write the initial value. Operation is not guaranteed if a value other than the initial value is written.
1, 0	—	00b	R	Reserved When read, the initial value is read. When writing, be sure to write the initial value. Operation is not guaranteed if a value other than the initial value is written.

6.3.13 Slave Access Control Register 10 (SYS_SLVACCCTL10)

This register sets the security levels for determining whether to enable or disable access to each set of registers in the LSI control register in SYSC.

Bit	31	30	29	28	27	26	25	24	23	22	21	20	19	18	17	16
	—	—	—	—	—	—	—	—	—	—	—	—	—	—	—	—
Initial Value	0	0	0	0	0	0	0	0	0	0	0	0	0	0	0	0
R/W	R	R	R	R	R	R	R	R	R	R	R	R	R	R	R	R
Bit	15	14	13	12	11	10	9	8	7	6	5	4	3	2	1	0
	—	—	—	—	—	—	—	—	—	—	—	—	—	—	—	LSI_SL
Initial Value	0	0	0	0	0	0	0	0	0	0	0	0	0	0	0	0
R/W	R	R	R	R	R	R	R	R	R	R	R	R	R	R	R/W	R/W

Bit	Bit Name	Initial Value	R/W	Description
31 to 2	—	All 0	R	Reserved Whenever it is read, 0 is read. The written value will be ignored.
1, 0	LSI_SL	00b	R/W	SYSC <LSI Control Reg> slave access permission control Set the security level SL [1:0] for the LSI control register in SYSC.

6.3.14 Slave Access Control Register 12 (SYS_SLVACCCTL12)

This register sets the security levels for determining whether to enable or disable access to each set of registers in the AOF control register in SYSC.

Bit	31	30	29	28	27	26	25	24	23	22	21	20	19	18	17	16
	—	—	—	—	—	—	—	—	—	—	—	—	—	—	—	—
Initial Value	0	0	0	0	0	0	0	0	0	0	0	0	0	0	0	0
R/W	R	R	R	R	R	R	R	R	R	R	R	R	R	R	R	R
Bit	15	14	13	12	11	10	9	8	7	6	5	4	3	2	1	0
	—	—	—	—	—	—	—	—	—	—	—	—	—	—	AOF_SL	
Initial Value	0	0	0	0	0	0	0	0	0	0	0	0	0	0	0	0
R/W	R	R	R	R	R	R	R	R	R	R	R	R	R	R	R/W	R/W

Bit	Bit Name	Initial Value	R/W	Description
31 to 2	—	All 0	R	Reserved Whenever it is read, 0 is read. The written value will be ignored.
1, 0	AOF_SL	00b	R/W	SYSC <AOF Control Reg> slave access permission control Set the security level SL [1:0] for the AOF control register in SYSC.

6.3.15 Slave Access Control Register 13 (SYS_SLVACCCTL13)

This register sets the security levels for determining whether to enable or disable access to each set of registers in the Low Power Mode control register in SYSC.

Bit	31	30	29	28	27	26	25	24	23	22	21	20	19	18	17	16
	—	—	—	—	—	—	—	—	—	—	—	—	—	—	—	—
Initial Value	0	0	0	0	0	0	0	0	0	0	0	0	0	0	0	0
R/W	R	R	R	R	R	R	R	R	R	R	R	R	R	R	R	R
Bit	15	14	13	12	11	10	9	8	7	6	5	4	3	2	1	0
	—	—	—	—	—	—	—	—	—	—	—	—	—	—	LP_SL	
Initial Value	0	0	0	0	0	0	0	0	0	0	0	0	0	0	0	0
R/W	R	R	R	R	R	R	R	R	R	R	R	R	R	R	R/W	R/W

Bit	Bit Name	Initial Value	R/W	Description
31 to 2	—	All 0	R	Reserved Whenever it is read, 0 is read. The written value will be ignored.
1, 0	LP_SL	00b	R/W	SYSC <Low Power Mode Control Reg> slave access permission control Set the security level SL [1:0] for the Low Power Mode control register in SYSC.

6.3.16 Slave Access Control Register 14 (SYS_SLVACCCTL14)

This register sets the security levels for determining whether to enable or disable access to each set of registers in the general-purpose register in SYSC.

Bit	31	30	29	28	27	26	25	24	23	22	21	20	19	18	17	16
	—	—	—	—	—	—	—	—	—	—	—	—	—	—	—	—
Initial Value	0	0	0	0	0	0	0	0	0	0	0	0	0	0	0	0
R/W	R	R	R	R	R	R	R	R	R	R	R	R	R	R	R	R
Bit	15	14	13	12	11	10	9	8	7	6	5	4	3	2	1	0
	—	—	—	—	—	—	—	—	—	—	—	—	—	—	GPREG_SL	
Initial Value	0	0	0	0	0	0	0	0	0	0	0	0	0	0	0	0
R/W	R	R	R	R	R	R	R	R	R	R	R	R	R	R	R/W	R/W

Bit	Bit Name	Initial Value	R/W	Description
31 to 2	—	All 0	R	Reserved Whenever it is read, 0 is read. The written value will be ignored.
1, 0	GPREG_SL	00b	R/W	SYSC <GPREG> slave access permission control Set the security level SL [1:0] for the General purpose register(GPREG) in SYSC.

6.3.17 ECCRAM0 ECC Setting Register (SYS_RAM0_ECC)

This register is a register that enables and disables the ECC function of ECCRAM0 (SRAM ACPU).

Bit	31	30	29	28	27	26	25	24	23	22	21	20	19	18	17	16
	—	—	—	—	—	—	—	—	—	—	—	—	—	—	—	—
Initial Value	0	0	0	0	0	0	0	0	0	0	0	0	0	0	0	0
R/W	R	R	R	R	R	R	R	R	R	R	R	R	R	R	R	R
Bit	15	14	13	12	11	10	9	8	7	6	5	4	3	2	1	0
	—	—	—	—	—	—	—	—	—	—	—	—	—	—	—	VECCEN
Initial Value	0	0	0	0	0	0	0	0	0	0	0	0	0	0	0	0
R/W	R	R	R	R	R	R	R	R	R	R	R	R	R	R	R	R/W

Bit	Bit Name	Initial Value	R/W	Description
31 to 1	—	All 0	R	Reserved When read, the initial value is read. When writing, be sure to write the initial value. Operation is not guaranteed if a value other than the initial value is written.
0	VECCEN	0	R/W	Set enable or disable error correction for ECCRAM0 (SRAM ACPU) 0: ECC function disabled 1: ECC function enabled

6.3.18 ECCRAM0 Access Control Register (SYS_RAM0_EN)

This register is a register that controls access to ECCRAM0 (SRAM ACPU).

Bit	31	30	29	28	27	26	25	24	23	22	21	20	19	18	17	16
	—	—	—	—	—	—	—	—	—	—	—	—	—	—	—	—
Initial Value	0	0	0	0	0	0	0	0	0	0	0	0	0	0	0	0
R/W	R	R	R	R	R	R	R	R	R	R	R	R	R	R	R	R
Bit	15	14	13	12	11	10	9	8	7	6	5	4	3	2	1	0
	—	—	—	—	—	—	—	—	—	—	—	—	—	—	VLWEN	VCEN
Initial Value	0	0	0	0	0	0	0	0	0	0	0	0	0	0	1	1
R/W	R	R	R	R	R	R	R	R	R	R	R	R	R	R	R/W	R/W

Bit	Bit Name	Initial Value	R/W	Description
31 to 2	—	All 0	R	Reserved Whenever it is read, 0 is read. The written value will be ignored.
1	VLWEN	1	R/W	Set enable or disable writes to ECRAM0 (SRAM ACPU) 0: Write disabled 1: Write enabled
0	VCEN	1	R/W	Set enable or disable access to ECRAM0 (SRAM ACPU) 0: Access disabled 1: Access enabled

6.3.19 ECCRAM1 ECC Setting Register (SYS_RAM1_ECC)

This register is a register that enables and disables the ECC function of ECCRAM1 (SRAM M CPU).

Bit	31	30	29	28	27	26	25	24	23	22	21	20	19	18	17	16
	—	—	—	—	—	—	—	—	—	—	—	—	—	—	—	—
Initial Value	0	0	0	0	0	0	0	0	0	0	0	0	0	0	0	0
R/W	R	R	R	R	R	R	R	R	R	R	R	R	R	R	R	R
Bit	15	14	13	12	11	10	9	8	7	6	5	4	3	2	1	0
	—	—	—	—	—	—	—	—	—	—	—	—	—	—	—	VECCEN
Initial Value	0	0	0	0	0	0	0	0	0	0	0	0	0	0	0	0
R/W	R	R	R	R	R	R	R	R	R	R	R	R	R	R	R	R/W

Bit	Bit Name	Initial Value	R/W	Description
31 to 1	—	All 0	R	Reserved When read, the initial value is read. When writing, be sure to write the initial value. Operation is not guaranteed if a value other than the initial value is written.
0	VECCEN	0	R/W	Set enable or disable error correction for ECCRAM1 (SRAM M CPU) 0: ECC function disabled 1: ECC function enabled

6.3.20 ECCRAM1 Access Control Register (SYS_RAM1_EN)

This register is the register that controls access to ECCRAM1 (SRAM M CPU).

Bit	31	30	29	28	27	26	25	24	23	22	21	20	19	18	17	16
	—	—	—	—	—	—	—	—	—	—	—	—	—	—	—	—
Initial Value	0	0	0	0	0	0	0	0	0	0	0	0	0	0	0	0
R/W	R	R	R	R	R	R	R	R	R	R	R	R	R	R	R	R
Bit	15	14	13	12	11	10	9	8	7	6	5	4	3	2	1	0
	—	—	—	—	—	—	—	—	—	—	—	—	—	—	VLWEN	VCEN
Initial Value	0	0	0	0	0	0	0	0	0	0	0	0	0	0	1	1
R/W	R	R	R	R	R	R	R	R	R	R	R	R	R	R	R/W	R/W

Bit	Bit Name	Initial Value	R/W	Description
31 to 2	—	All 0	R	Reserved Whenever it is read, 0 is read. The written value will be ignored.
1	VLWEN	1	R/W	Set enable or disable writes to ECCRAM1 (SRAM M CPU) 0: Write disabled 1: Write enabled
0	VCEN	1	R/W	Set enable or disable access to ECRAM1 (SRAM M CPU) 0: Access disabled 1: Access enabled

6.3.21 WDT0 Control Register (SYS_WDT0_CTRL)

This register is the register that set the count control of WDT0.

Bit	31	30	29	28	27	26	25	24	23	22	21	20	19	18	17	16
	—	—	—	—	—	—	—	—	—	—	—	—	—	—	—	WDTSTOPMASK
Initial Value	0	0	0	0	0	0	0	0	0	0	0	0	0	0	0	1
R/W	R	R	R	R	R	R	R	R	R	R	R	R	R	R	R	R/W
Bit	15	14	13	12	11	10	9	8	7	6	5	4	3	2	1	0
	—	—	—	—	—	—	—	—	—	—	—	—	—	—	—	WDTSTOP
Initial Value	0	0	0	0	0	0	0	0	0	0	0	0	0	0	0	0
R/W	R	R	R	R	R	R	R	R	R	R	R	R	R	R	R	R/W

Bit	Bit Name	Initial Value	R/W	Description
31 to 17	—	All 0	R	Reserved Whenever it is read, 0 is read. The written value will be ignored.
16	WDTSTOPMASK	1	R/W	Controls the stop function of WDT0 (for AX45MP) from Debug Module during debugging. 0: Stops WDT0 counting during debugging. 1: Not stop WDT0 counting during debugging.
15 to 1	—	All 0	R	Reserved When read, the initial value is read. The written value will be ignored.
0	WDTSTOP	0	R/W	Set whether the WDT0 (for AX45MP) counter is forced to stop 0: Continue counting 1: Stop counting and hold the counter value

6.3.22 GEther0 Config Register (SYS_GETH0_CFG)

This register is the register that indicates the state of Ether ch0.

Bit	31	30	29	28	27	26	25	24	23	22	21	20	19	18	17	16
	—	—	—	—	—	—	—	FEC_GI GA_EN ABLE	—	—	—	—	—	—	—	—
Initial Value	0	0	0	0	0	0	0	0	0	0	0	0	0	0	0	0
R/W	R	R	R	R	R	R	R	R	R	R	R	R	R	R	R	R

Bit	15	14	13	12	11	10	9	8	7	6	5	4	3	2	1	0
	—	—	—	—	—	—	—	—	—	—	—	—	—	—	—	—
Initial Value	0	0	0	0	0	0	0	0	0	0	0	0	0	0	0	0
R/W	R	R	R	R	R	R	R	R	R	R	R	R	R	R	R	R

Bit	Bit Name	Initial Value	R/W	Description
31 to 25	—	All 0	R	Reserved Whenever it is read, 0 is read. The written value will be ignored.
24	FEC_GIGA_EN NABLE	0	R	Indicates the mode of speed for Ether ch0 0: 100M/1Mbps mod 1: 1Gbps mode
23 to 0	—	All 0	R	Reserved When read, the initial value is read. When writing, be sure to write the initial value. Operation is not guaranteed if a value other than the initial value is written.

6.3.23 Gether1 Config Register (SYS_GETH1_CFG)

This register is the register that indicates the state of Ether ch1.

Bit	31	30	29	28	27	26	25	24	23	22	21	20	19	18	17	16
	—	—	—	—	—	—	—	FEC_GIGA_ENABLE	—	—	—	—	—	—	—	—
Initial Value	0	0	0	0	0	0	0	0	0	0	0	0	0	0	0	0
R/W	R	R	R	R	R	R	R	R	R	R	R	R	R	R	R	R
Bit	15	14	13	12	11	10	9	8	7	6	5	4	3	2	1	0
	—	—	—	—	—	—	—	—	—	—	—	—	—	—	—	—
Initial Value	0	0	0	0	0	0	0	0	0	0	0	0	0	0	0	0
R/W	R	R	R	R	R	R	R	R	R	R	R	R	R	R	R	R

Bit	Bit Name	Initial Value	R/W	Description
31 to 25	—	All 0	R	Reserved Whenever it is read, 0 is read. The written value will be ignored.
24	FEC_GIGA_ENABLE	0	R	Indicates the mode of speed for Ether ch1 0: 100M/1Mbps mode 1: 1Gbps mode
23 to 0	—	All 0	R	Reserved When read, the initial value is read. When writing, be sure to write the initial value. Operation is not guaranteed if a value other than the initial value is written.

6.3.24 I2C0 Config Register (SYS_I2C0_CFG)

This register is a register that set the bypass mode of the analog filter of I2C ch0.

Bit	31	30	29	28	27	26	25	24	23	22	21	20	19	18	17	16
	—	—	—	—	—	—	—	—	—	—	—	—	—	—	—	—
Initial Value	0	0	0	0	0	0	0	0	0	0	0	0	0	0	0	0
R/W	R	R	R	R	R	R	R	R	R	R	R	R	R	R	R	R
Bit	15	14	13	12	11	10	9	8	7	6	5	4	3	2	1	0
	—	—	—	—	—	—	—	—	—	—	—	—	—	—	—	af_bypass
Initial Value	0	0	0	0	0	0	0	0	0	0	0	0	0	0	0	0
R/W	R	R	R	R	R	R	R	R	R	R	R	R	R	R	R	R/W

Bit	Bit Name	Initial Value	R/W	Description
31 to 1	—	All 0	R	Reserved When read, the initial value is read. When writing, be sure to write the initial value. Operation is not guaranteed if a value other than the initial value is written.
0	af_bypass	0	R/W	Set whether to bypass the analog filter for noise removal for the input terminals (RIIC0_SDA, RIIC0_SCL) of I2C ch0. 0: Noise reduction is performed using an analog filter for the input signal. 1: The input signal is bypassed an analog filter and noise reduction is not performed.

6.3.25 I2C1 Config Register (SYS_I2C1_CFG)

This register is a register that set the bypass mode of the analog filter of I2C ch1.

Bit	31	30	29	28	27	26	25	24	23	22	21	20	19	18	17	16
	—	—	—	—	—	—	—	—	—	—	—	—	—	—	—	—
Initial Value	0	0	0	0	0	0	0	0	0	0	0	0	0	0	0	0
R/W	R	R	R	R	R	R	R	R	R	R	R	R	R	R	R	R
Bit	15	14	13	12	11	10	9	8	7	6	5	4	3	2	1	0
	—	—	—	—	—	—	—	—	—	—	—	—	—	—	—	af_bypass
Initial Value	0	0	0	0	0	0	0	0	0	0	0	0	0	0	0	0
R/W	R	R	R	R	R	R	R	R	R	R	R	R	R	R	R	R/W

Bit	Bit Name	Initial Value	R/W	Description
31 to 1	—	All 0	R	Reserved When read, the initial value is read. When writing, be sure to write the initial value. Operation is not guaranteed if a value other than the initial value is written.
0	af_bypass	0	R/W	Set whether to bypass the analog filter for noise removal for the input terminals (RIIC1_SDA, RIIC1_SCL) of I2C ch1. 0: Noise reduction is performed using an analog filter for the input signal. 1: The input signal is bypassed an analog filter and noise reduction is not performed.

6.3.26 I2C2 Config Register (SYS_I2C2_CFG)

This register is a register that set the bypass mode of the analog filter of I2C ch2.

Bit	31	30	29	28	27	26	25	24	23	22	21	20	19	18	17	16
	—	—	—	—	—	—	—	—	—	—	—	—	—	—	—	—
Initial Value	0	0	0	0	0	0	0	0	0	0	0	0	0	0	0	0
R/W	R	R	R	R	R	R	R	R	R	R	R	R	R	R	R	R
Bit	15	14	13	12	11	10	9	8	7	6	5	4	3	2	1	0
	—	—	—	—	—	—	—	—	—	—	—	—	—	—	—	af_bypass
Initial Value	0	0	0	0	0	0	0	0	0	0	0	0	0	0	0	0
R/W	R	R	R	R	R	R	R	R	R	R	R	R	R	R	R	R/W

Bit	Bit Name	Initial Value	R/W	Description
31 to 1	—	All 0	R	Reserved When read, the initial value is read. When writing, be sure to write the initial value. Operation is not guaranteed if a value other than the initial value is written.
0	af_bypass	0	R/W	Set whether to bypass the analog filter for noise removal for the input terminals (RIIC2_SDA, RIIC2_SCL) of I2C ch2. 0: Noise reduction is performed using an analog filter for the input signal. 1: The input signal is bypassed an analog filter and noise reduction is not performed.

6.3.27 I2C3 Config Register (SYS_I2C3_CFG)

This register is a register that set the bypass mode of the analog filter of I2C ch3.

Bit	31	30	29	28	27	26	25	24	23	22	21	20	19	18	17	16
	—	—	—	—	—	—	—	—	—	—	—	—	—	—	—	—
Initial Value	0	0	0	0	0	0	0	0	0	0	0	0	0	0	0	0
R/W	R	R	R	R	R	R	R	R	R	R	R	R	R	R	R	R
Bit	15	14	13	12	11	10	9	8	7	6	5	4	3	2	1	0
	—	—	—	—	—	—	—	—	—	—	—	—	—	—	—	af_bypass
Initial Value	0	0	0	0	0	0	0	0	0	0	0	0	0	0	0	0
R/W	R	R	R	R	R	R	R	R	R	R	R	R	R	R	R	R/W

Bit	Bit Name	Initial Value	R/W	Description
31 to 1	—	All 0	R	Reserved When read, the initial value is read. When writing, be sure to write the initial value. Operation is not guaranteed if a value other than the initial value is written.
0	af_bypass	0	R/W	Set whether to bypass the analog filter for noise removal for the input terminals (RIIC3_SDA, RIIC3_SCL) of I2C ch3. 0: Noise reduction is performed using an analog filter for the input signal. 1: The input signal is bypassed an analog filter and noise reduction is not performed.

6.3.28 AX45MP Core0 Reset Vector Address Low Configuration Register (SYS_AX45MP_CFG_RVAL0)

This register is a register that set the reset vector address of AX45MP core0.

Bit	31	30	29	28	27	26	25	24	23	22	21	20	19	18	17	16
	RVBARADDRLO[31:0]															
Initial Value	0	0	0	0	0	0	0	0	0	0	0	0	0	0	0	0
R/W	R/W	R/W	R/W	R/W	R/W	R/W	R/W	R/W	R/W	R/W	R/W	R/W	R/W	R/W	R/W	R/W
Bit	15	14	13	12	11	10	9	8	7	6	5	4	3	2	1	0
	RVBARADDRLO[31:0]															
Initial Value	0	0	0	0	0	0	0	0	0	0	0	0	0	0	0	0
R/W	R/W	R/W	R/W	R/W	R/W	R/W	R/W	R/W	R/W	R/W	R/W	R/W	R/W	R/W	R/W	R/W

Bit	Bit Name	Initial Value	R/W	Description
31 to 0	RVBARADDRLO[31:0]	H'0000_000	R/W	Represent bottom bit 31 to bit 0 of the reset vector address of AX45MP Core0.

6.3.29 AX45MP Core0 Reset Vector Address High Configuration Register (SYS_AX45MP_CFG_RVAH0)

This register is a register that set the reset vector address of AX45MP core0.

Bit	31	30	29	28	27	26	25	24	23	22	21	20	19	18	17	16
	—	—	—	—	—	—	—	—	—	—	—	—	—	—	—	—
Initial Value	0	0	0	0	0	0	0	0	0	0	0	0	0	0	0	0
R/W	R	R	R	R	R	R	R	R	R	R	R	R	R	R	R	R
Bit	15	14	13	12	11	10	9	8	7	6	5	4	3	2	1	0
	—	—	—	—	—	—	—	—	—	RVBARADDRH0[6:0]						
Initial Value	0	0	0	0	0	0	0	0	0	0	0	0	0	0	0	0
R/W	R	R	R	R	R	R	R	R	R	R/W	R/W	R/W	R/W	R/W	R/W	R/W

Bit	Bit Name	Initial Value	R/W	Description
31 to 7	—	All 0	R	Reserved Whenever it is read, 0 is read. The written value will be ignored.
6 to 0	RVBARADDRH0[6:0]	H'00	R/W	Represent upper bit 38 to bit 32 of the reset vector address of AX45MP Core0.

6.3.30 AX45MP status Register (SYS_AX45MP_STATUS)

This register indicates the AX45MP status.

Bit	31	30	29	28	27	26	25	24	23	22	21	20	19	18	17	16
	—	—	—	—	—	—	—	—	—	—	—	STATUS[5]	—	—	—	STATUS[4]
Initial Value	0	0	0	0	0	0	0	0	0	0	0	0	0	0	0	0
R/W	R	R	R	R	R	R	R	R	R	R	R	R	R	R	R	R
Bit	15	14	13	12	11	10	9	8	7	6	5	4	3	2	1	0
	—	—	—	STATUS[3]	—	—	—	STATUS[2]	—	—	—	STATUS[1]	—	—	—	STATUS[0]
Initial Value	0	0	0	—	0	0	—	0	0	0	0	0	0	—	—	—
R/W	R	R	R	R	R	R	R	R	R	R	R	R	R	R	R	R

Bit	Bit Name	Initial Value	R/W	Description
31 to 21	—	All 0	R	Reserved Whenever it is read, 0 is read. The written value will be ignored.
20	STATUS[5]	0b	R	Represents processor is in stoptime.
19 to 17	—	All 0	R	Reserved Whenever it is read, 0 is read. The written value will be ignored.
16	STATUS[4]	0b	R	Represents processor is under reset.
15 to 13	—	All 0	R	Reserved Whenever it is read, 0 is read. The written value will be ignored.
12	STATUS[3]	0b	R	Represents processor is not available for access.
11 to 9	—	All 0	R	Reserved Whenever it is read, 0 is read. The written value will be ignored.
8	STATUS[2]	0b	R	Represents processor is halted.
7 to 5	—	All 0	R	Reserved Whenever it is read, 0 is read. The written value will be ignored.
4	STATUS[1]	0b	R	Represents the state of Error Interrupt.
3 to 1	—	All 0	R	Reserved Whenever it is read, 0 is read. The written value will be ignored.
0	STATUS[0]	B'0	R	Represents processor is in WFI mode.

6.3.31 LSI Mode Signal Register (SYS_LSI_MODE)

This register indicates the state of the MD_BOOT terminal, the DEBUGEN terminal, the MD_CLKS terminal, and the MD_OSCDRV terminal.

Bit	31	30	29	28	27	26	25	24	23	22	21	20	19	18	17	16
	—	—	—	—	—	—	—	—	—	—	—	—	—	—	—	STAT_SEC_EN
Initial Value	0	0	0	0	0	0	0	0	0	0	0	0	0	0	0	—
R/W	R	R	R	R	R	R	R	R	R	R	R	R	R	R	R	R
Bit	15	14	13	12	11	10	9	8	7	6	5	4	3	2	1	0
	STAT_MD_OSCDRV[1:0]		—	STAT_MD_CLKS	—	—	STAT_DEBUGEN	—	—	—	—	—	—	STAT_MD_BOOT[2:0]		
Initial Value	—	—	0	—	0	0	—	0	0	0	0	0	0	—	—	—
R/W	R	R	R	R	R	R	R	R	R	R	R	R	R	R	R	R

Bit	Bit Name	Initial Value	R/W	Description
31 to 17	—	All 0	R	Reserved Whenever it is read, 0 is read. The written value will be ignored.
16	STAT_SEC_EN	—	R	Indicates whether this LSI support the security function or not. 0: Not supported 1: Available
15, 14	STAT_MD_OSCDRV[1:0]	—	R	Indicates the terminal state of the external terminal MD_OSCDRV[1:0]. The value is updated at the rising edge of PRST#. If a reset occurs inside the LSI, this register is not updated.
13	—	0	R	Reserved Whenever it is read, 0 is read. The written value will be ignored.
12	STAT_MD_CLKS	—	R	Indicates the terminal state of the external terminal MD_CLKS. The value is updated at the rising edge of PRST#. If a reset occurs inside the LSI, this register is not updated.
11, 10	—	00b	R	Reserved Whenever it is read, 0 is read. The written value will be ignored.
9	STAT_DEBUGEN	—	R	Indicates the terminal state of the external terminal DEBUGEN. The value is updated at the rising edge of PRST#. If a reset occurs inside the LSI, this register is not updated.
8	—	0	R	Reserved When read, the initial value is read. When writing, be sure to write the initial value. Operation is not guaranteed if a value other than the initial value is written.
7 to 3	—	All 0	R	Reserved Whenever it is read, 0 is read. The written value will be ignored.
2 to 0	STAT_MD_BOOT[2:0]	—	R	Indicates the terminal state of the external terminal MD_BOOT[2:0]. The value is updated at the rising edge of PRST#. If a reset occurs inside the LSI, this register is not updated.

6.3.32 LSI Device ID Register (SYS_LSI_DEVID)

This register indicates the product specific device ID.

Bit	31	30	29	28	27	26	25	24	23	22	21	20	19	18	17	16
	DEV_ID[31:28]				DEV_ID[27:0]											
Initial Value	—	—	—	—	1	0	0	0	0	1	0	0	0	1	1	1
R/W	R	R	R	R	R	R	R	R	R	R	R	R	R	R	R	R
Bit	15	14	13	12	11	10	9	8	7	6	5	4	3	2	1	0
	DEV_ID[27:0]															
Initial Value	1	1	0	0	0	1	0	0	0	1	0	0	0	1	1	1
R/W	R	R	R	R	R	R	R	R	R	R	R	R	R	R	R	R

Bit	Bit Name	Initial Value	R/W	Description
31 to 28	DEV_ID [31:28]	—	R	Indicates the product revision.
27 to 0	DEV_ID[27:0]	H'847_C4 47	R	Indicates the product specific fixed value.

6.3.33 LSI Product Register (SYS_LSI_PRR)

This register indicates information about product options.

Bit	31	30	29	28	27	26	25	24	23	22	21	20	19	18	17	16
	—	—	—	—	—	—	—	—	—	—	—	—	—	—	—	—
Initial Value	0	0	0	0	0	0	0	0	0	0	0	—	0	0	0	—
R/W	R	R	R	R	R	R	R	R	R	R	R	R	R	R	R	R
Bit	15	14	13	12	11	10	9	8	7	6	5	4	3	2	1	0
	—	—	—	—	—	—	—	—	—	—	—	—	—	—	—	—
Initial Value	0	0	0	—	0	0	0	—	0	0	0	—	0	0	0	—
R/W	R	R	R	R	R	R	R	R	R	R	R	R	R	R	R	R

Bit	Bit Name	Initial Value	R/W	Description
31 to 21	—	All 0	R	Reserved Whenever it is read, 0 is read. The written value will be ignored.
20	—	—	R	Reserved When read, the initial value is read. The written value will be ignored.
19 to 17	—	All 0	R	Reserved Whenever it is read, 0 is read. The written value will be ignored.
16	—	—	R	Reserved When read, the initial value is read. The written value will be ignored.
15 to 13	—	All 0	R	Reserved Whenever it is read, 0 is read. The written value will be ignored.
12	—	—	R	Reserved When read, the initial value is read. The written value will be ignored.
11 to 9	—	All 0	R	Reserved Whenever it is read, 0 is read. The written value will be ignored.
8	—	—	R	Reserved When read, the initial value is read. The written value will be ignored.
7 to 5	—	All 0	R	Reserved Whenever it is read, 0 is read. The written value will be ignored.
4	—	—	R	Reserved When read, the initial value is read. The written value will be ignored.
3 to 1	—	All 0	R	Reserved Whenever it is read, 0 is read. The written value will be ignored.
0	—	—	R	Reserved When read, the initial value is read. The written value will be ignored.

6.3.34 Address Offset Register0 (SYS_AOF0)

This register is an address offset register for accessing the 34-bit address space from SD ch0/ch1.

Bit	31	30	29	28	27	26	25	24	23	22	21	20	19	18	17	16
	OFS11_SXSDHI_1				OFS10_SXSDHI_1				OFS01_SXSDHI_1				OFS00_SXSDHI_1			
Initial Value	0	0	1	1	0	0	1	0	0	0	0	1	0	0	0	0
R/W	R/W	R/W	R/W	R/W	R/W	R/W	R/W	R/W	R/W	R/W	R/W	R/W	R/W	R/W	R/W	R/W
Bit	15	14	13	12	11	10	9	8	7	6	5	4	3	2	1	0
	OFS11_SXSDHI_0				OFS10_SXSDHI_0				OFS01_SXSDHI_0				OFS00_SXSDHI_0			
Initial Value	0	0	1	1	0	0	1	0	0	0	0	1	0	0	0	0
R/W	R/W	R/W	R/W	R/W	R/W	R/W	R/W	R/W	R/W	R/W	R/W	R/W	R/W	R/W	R/W	R/W

Bit	Bit Name	Initial Value	R/W	Description
31 to 28	OFS11_SXS DHI_1	0011b	R/W	Conversion value to address [33:30] when SD ch1 address [31:30] = 11* ¹
27 to 24	OFS10_SXS DHI_1	0010b	R/W	Conversion value to address [33:30] when SD ch1 address [31:30] = 10* ¹
23 to 20	OFS01_SXS DHI_1	0001b	R/W	Conversion value to address [33:30] when SD ch1 address [31:30] = 01* ¹
19 to 16	OFS00_SXS DHI_1	0000b	R/W	Conversion value to address [33:30] when SD ch1 address [31:30] = 00* ¹
15 to 12	OFS11_SXS DHI_0	0011b	R/W	Conversion value to address [33:30] when SD ch0 address [31:30] = 11* ¹
11 to 8	OFS10_SXS DHI_0	0010b	R/W	Conversion value to address [33:30] when SD ch0 address [31:30] = 10* ¹
7 to 4	OFS01_SXS DHI_0	0001b	R/W	Conversion value to address [33:30] when SD ch0 address [31:30] = 01* ¹
3 to 0	OFS00_SXS DHI_0	0000b	R/W	Conversion value to address [33:30] when SD ch0 address [31:30] = 00* ¹

Note 1. Master SD ch0/ch1 are the master of 32bit addresses (4 Gbytes space). Depending on the address value (in 1 GB) of the master address [31:30], you can access the address converted to the address space [33:30]. This gives you access to more than 4 Gbytes of space. This register setting is prohibited from changing the setting while the target master is in operation. Please change it while the access on the master side is stopped.

6.3.35 Address Offset Register1 (SYS_AOF1)

This register is an address offset register for accessing the 34-bit address space from Ether ch0/ch1.

Bit	31	30	29	28	27	26	25	24	23	22	21	20	19	18	17	16
	OFS11_SXGIGE_1				OFS10_SXGIGE_1				OFS01_SXGIGE_1				OFS00_SXGIGE_1			
Initial Value	0	0	1	1	0	0	1	0	0	0	0	1	0	0	0	0
R/W	R/W	R/W	R/W	R/W	R/W	R/W	R/W	R/W	R/W	R/W	R/W	R/W	R/W	R/W	R/W	R/W
Bit	15	14	13	12	11	10	9	8	7	6	5	4	3	2	1	0
	OFS11_SXGIGE_0				OFS10_SXGIGE_0				OFS01_SXGIGE_0				OFS00_SXGIGE_0			
Initial Value	0	0	1	1	0	0	1	0	0	0	0	1	0	0	0	0
R/W	R/W	R/W	R/W	R/W	R/W	R/W	R/W	R/W	R/W	R/W	R/W	R/W	R/W	R/W	R/W	R/W

Bit	Bit Name	Initial Value	R/W	Description
31 to 28	OFS11_SXGI GE_1	0011b	R/W	Conversion value to address [33:30] when Ether ch1 address [31:30] = 11* ¹
27 to 24	OFS10_SXGI GE_1	0010b	R/W	Conversion value to address [33:30] when Ether ch1 address [31:30] = 10* ¹
23 to 20	OFS01_SXGI GE_1	0001b	R/W	Conversion value to address [33:30] when Ether ch1 address [31:30] = 01* ¹
19 to 16	OFS00_SXGI GE_1	0000b	R/W	Conversion value to address [33:30] when Ether ch1 address [31:30] = 00* ¹
15 to 12	OFS11_SXGI GE_0	0011b	R/W	Conversion value to address [33:30] when Ether ch0 address [31:30] = 11* ¹
11 to 8	OFS10_SXGI GE_0	0010b	R/W	Conversion value to address [33:30] when Ether ch0 address [31:30] = 10* ¹
7 to 4	OFS01_SXGI GE_0	0001b	R/W	Conversion value to address [33:30] when Ether ch0 address [31:30] = 01* ¹
3 to 0	OFS00_SXGI GE_0	0000b	R/W	Conversion value to address [33:30] when Ether ch0 address [31:30] = 00* ¹

Note 1. Master Ether ch0/ch1 are the master of 32bit addresses (4 Gbytes space). Depending on the address value (in 1 GB) of the master address [31:30], you can access the address converted to the address space [33:30]. This gives you access to more than 4 Gbytes of space. This register setting is prohibited from changing the setting while the target master is in operation. Please change it while the access on the master side is stopped.

6.3.36 Address Offset Register2 (SYS_AOF2)

This register is an address offset register for accessing the 34-bit address space from USB2.0 ch0/ch1 Host.

Bit	31	30	29	28	27	26	25	24	23	22	21	20	19	18	17	16
	OFS11_SXUSB2_1				OFS10_SXUSB2_1				OFS01_SXUSB2_1				OFS00_SXUSB2_1			
Initial Value	0	0	1	1	0	0	1	0	0	0	0	1	0	0	0	0
R/W	R/W	R/W	R/W	R/W	R/W	R/W	R/W	R/W	R/W	R/W	R/W	R/W	R/W	R/W	R/W	R/W
Bit	15	14	13	12	11	10	9	8	7	6	5	4	3	2	1	0
	OFS11_SXUSB2_0_H				OFS10_SXUSB2_0_H				OFS01_SXUSB2_0_H				OFS00_SXUSB2_0_H			
Initial Value	0	0	1	1	0	0	1	0	0	0	0	1	0	0	0	0
R/W	R/W	R/W	R/W	R/W	R/W	R/W	R/W	R/W	R/W	R/W	R/W	R/W	R/W	R/W	R/W	R/W

Bit	Bit Name	Initial Value	R/W	Description
31 to 28	OFS11_SXU SB2_1	0011b	R/W	Conversion value to address [33:30] when USB2.0 ch1 Host address [31:30] = 11* ¹
27 to 24	OFS10_SXU SB2_1	0010b	R/W	Conversion value to address [33:30] when USB2.0 ch1 Host address [31:30] = 10* ¹
23 to 20	OFS01_SXU SB2_1	0001b	R/W	Conversion value to address [33:30] when USB2.0 ch1 Host address [31:30] = 01* ¹
19 to 16	OFS00_SXU SB2_1	0000b	R/W	Conversion value to address [33:30] when USB2.0 ch1 Host address [31:30] = 00* ¹
15 to 12	OFS11_SXU SB2_0_H	0011b	R/W	Conversion value to address [33:30] when USB2.0 ch0 Host address [31:30] = 11* ¹
11 to 8	OFS10_SXU SB2_0_H	0010b	R/W	Conversion value to address [33:30] when USB2.0 ch0 Host address [31:30] = 10* ¹
7 to 4	OFS01_SXU SB2_0_H	0001b	R/W	Conversion value to address [33:30] when USB2.0 ch0 Host address [31:30] = 01* ¹
3 to 0	OFS00_SXU SB2_0_H	0000b	R/W	Conversion value to address [33:30] when USB2.0 ch0 Host address [31:30] = 00* ¹

Note 1. Master USB2.0 ch0/ch1 Host are the master of 32bit addresses (4 Gbytes space). Depending on the address value (in 1 GB) of the master address [31:30], you can access the address converted to the address space [33:30]. This gives you access to more than 4 Gbytes of space. This register setting is prohibited from changing the setting while the target master is in operation. Please change it while the access on the master side is stopped.

6.3.37 Address Offset Register3 (SYS_AOF3)

This register is an address offset register for accessing the 34-bit address space from USB2.0 ch0 Function.

Bit	31	30	29	28	27	26	25	24	23	22	21	20	19	18	17	16
	—	—	—	—	—	—	—	—	—	—	—	—	—	—	—	—
Initial Value	0	0	0	0	0	0	0	0	0	0	0	0	0	0	0	0
R/W	R	R	R	R	R	R	R	R	R	R	R	R	R	R	R	R
Bit	15	14	13	12	11	10	9	8	7	6	5	4	3	2	1	0
	OFS11_SXUSB2_0_F				OFS10_SXUSB2_0_F				OFS01_SXUSB2_0_F				OFS00_SXUSB2_0_F			
Initial Value	0	0	1	1	0	0	1	0	0	0	0	1	0	0	0	0
R/W	R/W	R/W	R/W	R/W	R/W	R/W	R/W	R/W	R/W	R/W	R/W	R/W	R/W	R/W	R/W	R/W

Bit	Bit Name	Initial Value	R/W	Description
31 to 16	—	All 0	R	Reserved Whenever it is read, 0 is read. The written value will be ignored.
15 to 12	OFS11_SXUSB2_0_F	0011b	R/W	Conversion value to address [33:30] when USB2.0 ch0 Function address [31:30] = 11* ¹
11 to 8	OFS10_SXUSB2_0_F	0010b	R/W	Conversion value to address [33:30] when USB2.0 ch0 Function address [31:30] = 10* ¹
7 to 4	OFS01_SXUSB2_0_F	0001b	R/W	Conversion value to address [33:30] when USB2.0 ch0 Function address [31:30] = 01* ¹
3 to 0	OFS00_SXUSB2_0_F	0000b	R/W	Conversion value to address [33:30] when USB2.0 ch0 Function address [31:30] = 00* ¹

Note 1. Master USB2.0 ch0 Function is the master of 32bit addresses (4 Gbytes space). Depending on the address value (in 1 GB) of the master address [31:30], you can access the address converted to the address space [33:30]. This gives you access to more than 4 Gbytes of space. This register setting is prohibited from changing the setting while the target master is in operation. Please change it while the access on the master side is stopped.

6.3.38 Address Offset Register6 (SYS_AOF6)

This register is an address offset register for accessing the 34-bit address space from Secure/Non-Secure DMAC.

Bit	31	30	29	28	27	26	25	24	23	22	21	20	19	18	17	16
	OFS11_SXDMAC_NS				OFS10_SXDMAC_NS				OFS01_SXDMAC_NS				OFS00_SXDMAC_NS			
Initial Value	0	0	1	1	0	0	1	0	0	0	0	1	0	0	0	0
R/W	R/W	R/W	R/W	R/W	R/W	R/W	R/W	R/W	R/W	R/W	R/W	R/W	R/W	R/W	R/W	R/W
Bit	15	14	13	12	11	10	9	8	7	6	5	4	3	2	1	0
	OFS11_SXDMAC_S				OFS10_SXDMAC_S				OFS01_SXDMAC_S				OFS00_SXDMAC_S			
Initial Value	0	0	1	1	0	0	1	0	0	0	0	1	0	0	0	0
R/W	R/W	R/W	R/W	R/W	R/W	R/W	R/W	R/W	R/W	R/W	R/W	R/W	R/W	R/W	R/W	R/W

Bit	Bit Name	Initial Value	R/W	Description
31 to 28	OFS11_SXD MAC_NS	0011b	R/W	Conversion value to address [33:30] when Non-Secure DMAC address [31:30] = 11* ¹
27 to 24	OFS10_SXD MAC_NS	0010b	R/W	Conversion value to address [33:30] when Non-Secure DMAC address [31:30] = 10* ¹
23 to 20	OFS01_SXD MAC_NS	0001b	R/W	Conversion value to address [33:30] when Non-Secure DMAC address [31:30] = 01* ¹
19 to 16	OFS00_SXD MAC_NS	0000b	R/W	Conversion value to address [33:30] when Non-Secure DMAC address [31:30] = 00* ¹
15 to 12	OFS11_SXD MAC_S	0011b	R/W	Conversion value to address [33:30] when Secure DMAC address [31:30] = 11* ¹
11 to 8	OFS10_SXD MAC_S	0010b	R/W	Conversion value to address [33:30] when Secure DMAC address [31:30] = 10* ¹
7 to 4	OFS01_SXD MAC_S	0001b	R/W	Conversion value to address [33:30] when Secure DMAC address [31:30] = 01* ¹
3 to 0	OFS00_SXD MAC_S	0000b	R/W	Conversion value to address [33:30] when Secure DMAC address [31:30] = 00* ¹

Note 1. Master Secure/Non-Secure DMAC are the master of 32bit addresses (4 Gbytes space). Depending on the address value (in 1 GB) of the master address [31:30], you can access the address converted to the address space [33:30]. This gives you access to more than 4 Gbytes of space. This register setting is prohibited from changing the setting while the target master is in operation. Please change it while the access on the master side is stopped.

6.3.39 General Register0 (SYS_GPREG_0)

This register is a general-purpose register.

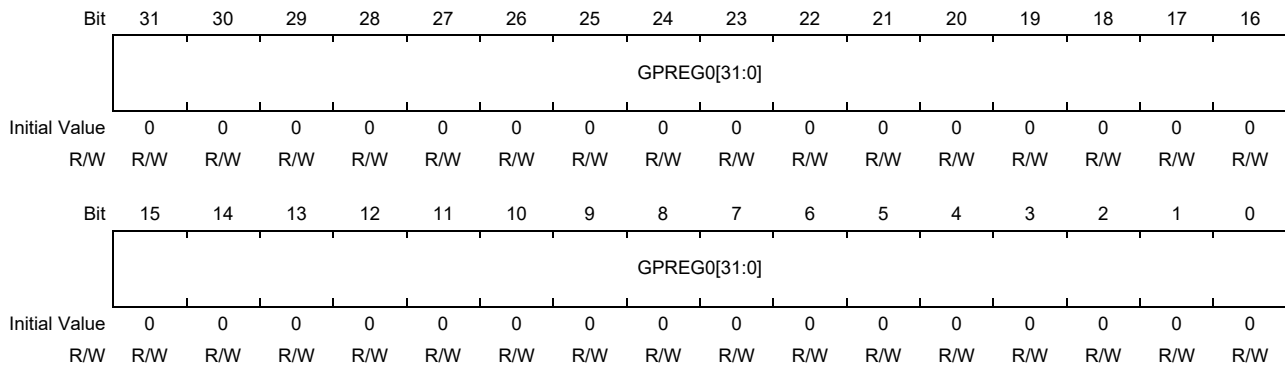

Bit	Bit Name	Initial Value	R/W	Description
31 to 0	GPREG0 [31:0]	H'0000_000	R/W	General-purpose register 0 It is a 32-bit register. It is possible to write any value, read the written value.

6.3.40 General Register1 (SYS_GPREG_1)

This register is a general-purpose register.

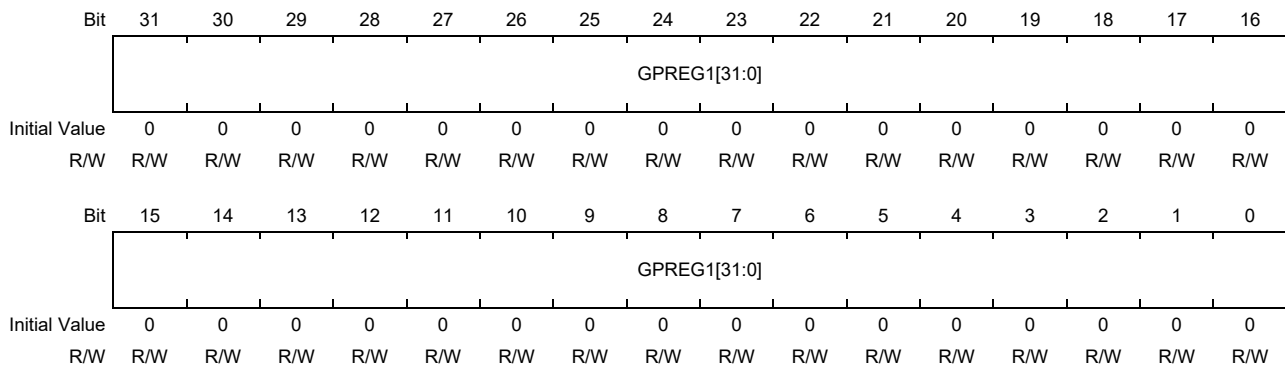

Bit	Bit Name	Initial Value	R/W	Description
31 to 0	GPREG1 [31:0]	H'0000_000	R/W	General-purpose register 1 It is a 32-bit register. It is possible to write any value, read the written value.

6.3.41 General Register2 (SYS_GPREG_2)

This register is a general-purpose register.

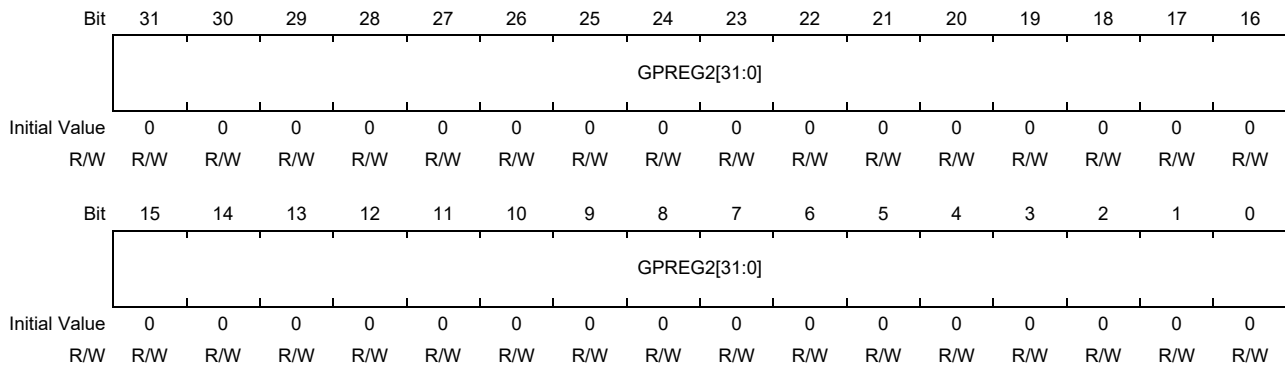

Bit	Bit Name	Initial Value	R/W	Description
31 to 0	GPREG2 [31:0]	H'0000_0000	R/W	General-purpose register 2 It is a 32-bit register. It is possible to write any value, read the written value.

6.3.42 General Register3 (SYS_GPREG_3)

This register is a general-purpose register.

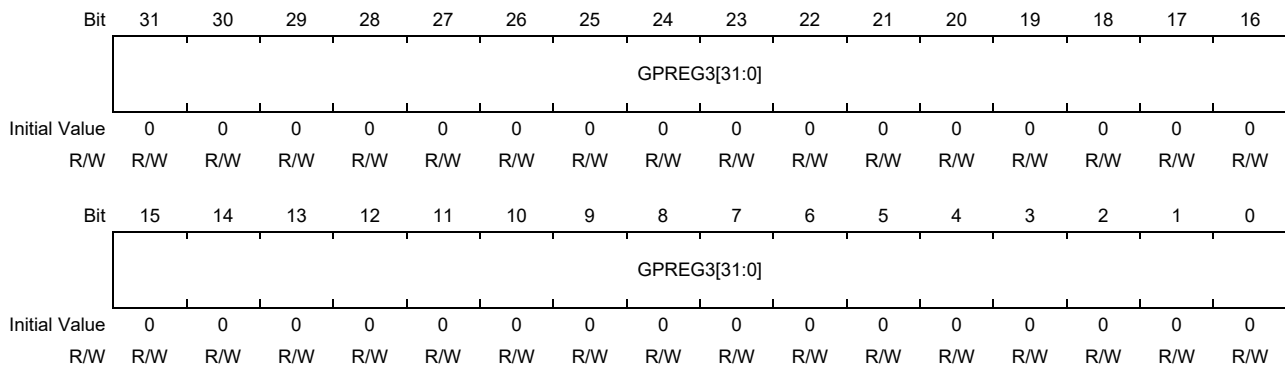

Bit	Bit Name	Initial Value	R/W	Description
31 to 0	GPREG3 [31:0]	H'0000_0000	R/W	General-purpose register 3 It is a 32-bit register. It is possible to write any value, read the written value.

6.4 Operation

6.4.1 External Terminal State Capture Function

Captures the state of the following four external terminals at the rising edge of PRST# terminal and holds them into the SYS_LSI_MODE register. The value is not updated by a reset that occurs inside the LSI.

- MD_BOOT[2:0]
- DEBUGEN
- MD_CLKS
- MD_OSCDRV[1:0]

6.4.2 WDT Stop Control Function

By writing 1 to the WDTSTOP bit of the SYS_WDTn_CTRL register (n: 0), the following WDT corresponding to n is forcibly stopped and the count value is retained.

Also, by writing 1 to the WDTSTOPMASK bit of the SYS_WDTn_CTRL register (n: 0), the following WDT count corresponding to n can be continued even during debugging. If 0 is written, the WDT count will stop during debugging.

n	Stop WDT
0	WDT0 (for AX45MP core0)

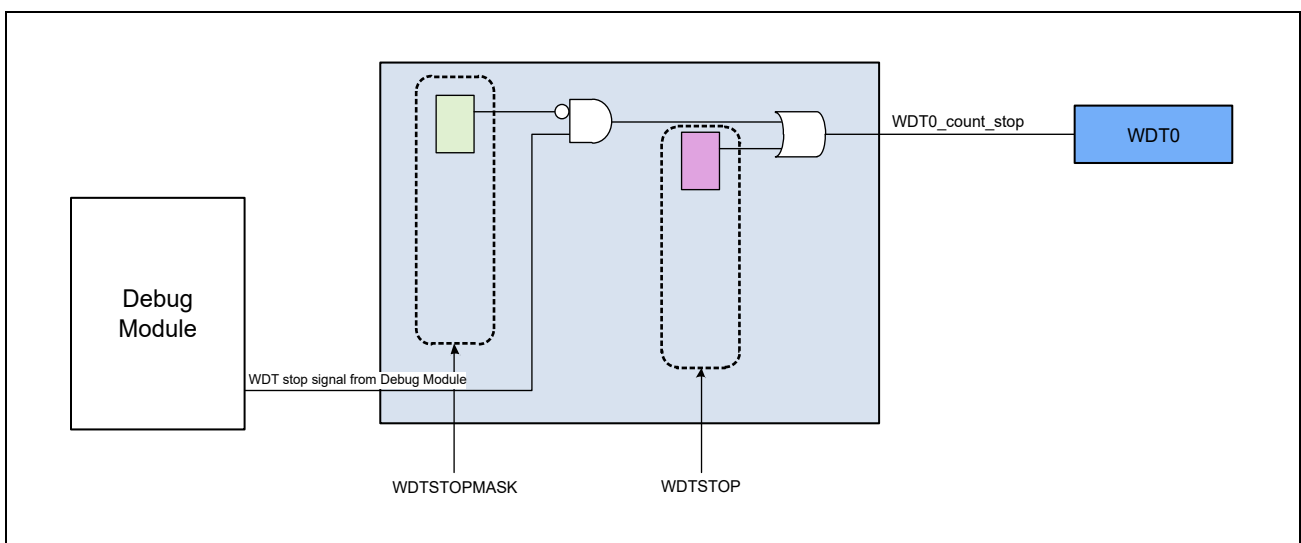

Figure 6.2 Overview of WDT Stop Function

7. Clock Pulse Generator (CPG)

This chapter describes the functions of the clock pulse generator module (CPG).

7.1 Features

7.1.1 Overview

Table 7.1 provides a list of CPG features.

Table 7.1 List of functions

Features	Specification
PLL control	<ul style="list-style-type: none"> • SSCG control, PLL multiplication factor setting, and ON/OFF control are performed by register setting. • This LSI is equipped with 5 PLLs. The roles of each are as follows: <ul style="list-style-type: none"> – PLL1 (SSCG-PLL: Default SSCG ON): AX45MP only – PLL2 (SSCG-PLL: Default SSCG OFF): For SYSTEM-BUS & Module (no SSCG) – PLL3 (SSCG-PLL: Default SSCG ON): For SYSTEM-BUS & Module (SSCG Yes) – PLL4 (SSCG-PLL: Default SSCG ON): DDR-SDRAM Only – PLL6 (SSCG-PLL: Default SSCG OFF): Gigabit Ethernet Interface • Initial value of SSCG for each PLL (PLL3 is fixed): <ul style="list-style-type: none"> – Fmod: 31.25kHz – Spread: Down spread – Modulation Depth: 2.25% (PLL1, PLL4 and, PLL6) 2.20% (PLL3)
Clock generation and control	<p>The clock to be supplied to each module is generated from the external clock input (EXCLK), crystal oscillator input / output (XIN / XOUT), or PLL output clock.</p> <ul style="list-style-type: none"> • Selection of the peri-ratio by register setting • Clock path selection by clock selector by register setting • Clock supply ON/OFF control is performed by register setting. (Module Standby Mode control)
Reset generation and control	<p>A reset is generated from the reset factor in (). The types of reset are as follows.</p> <ul style="list-style-type: none"> • System reset (external pin) • Software reset (system reboot, reset control of each module) • Watchdog reset (WDT module) • ON/OFF control for each unit clock (software control)
Monitor	<ul style="list-style-type: none"> • PLL clock monitor <ul style="list-style-type: none"> – The function to monitor the operation of the output clocks from PLL1 to PLL4 and PLL6 • Clock monitor for each module <ul style="list-style-type: none"> – Function to monitor that the clock monitor is operating • Reset monitor <ul style="list-style-type: none"> – Function to monitor the reset status of each module

7.1.2 CPG configuration

Figure 7.1 shows the CPG configuration.

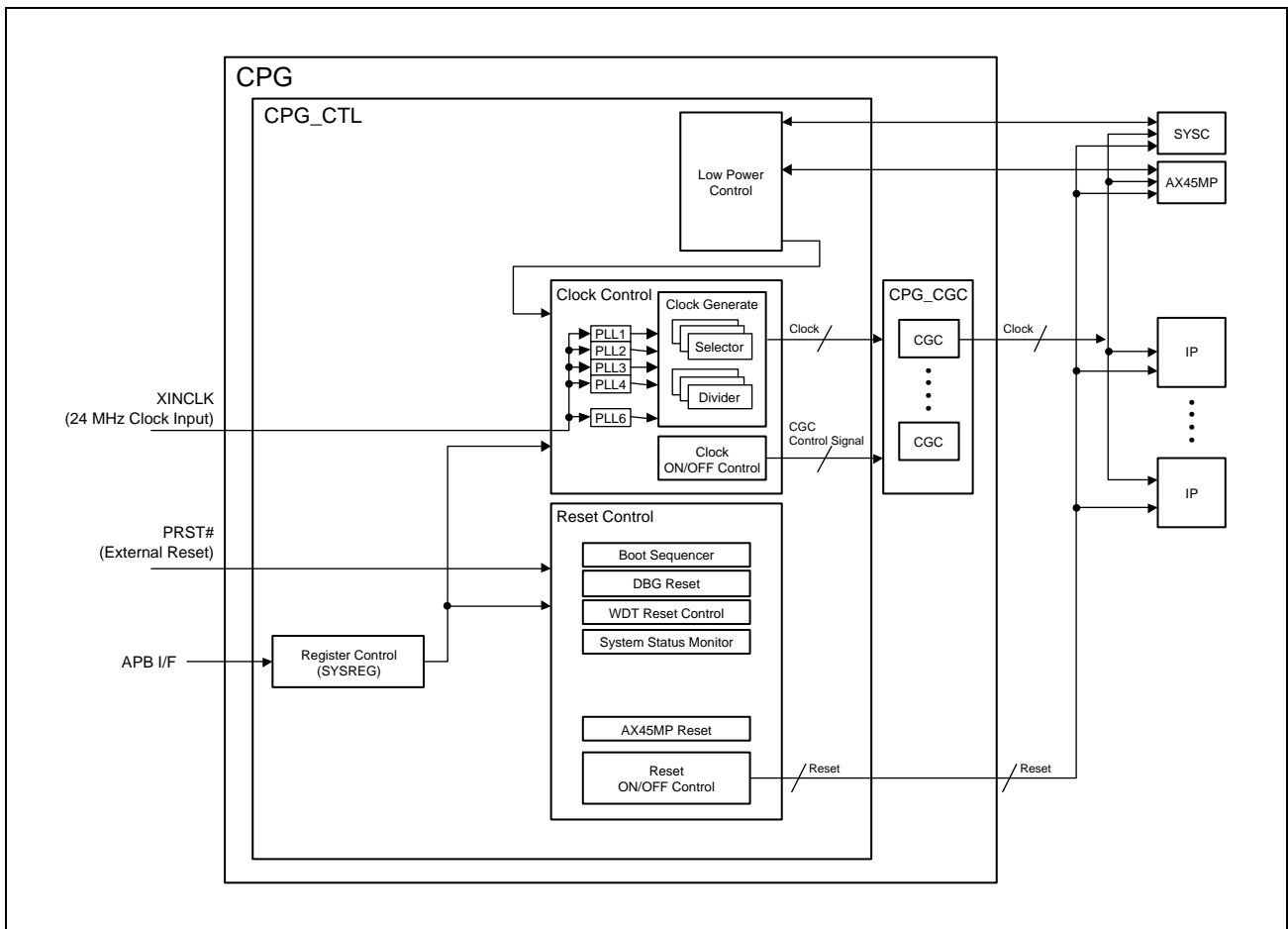

Figure 7.1 CPG Configuration

7.1.3 Pin description

The table below shows a list of CPG pins.

Table 7.2 Pin List

Name	Pin Name	IO	Functions
Mode control pin	MD_BOOT0	I	Set the operating mode.
	MD_BOOT1	I	Do not change during PRST# pin asserts and after negating until the operating mode is confirmed.
	MD_BOOT2	I	
	MD_CLKS	I	Set ON/OFF of SSCG circuit operation of PLL3. Do not change during PRST# terminal asserts and after negating until the operating mode is confirmed.
External clock Input pin ^{*2}	EXCLK	I	This is the pin to input the external clock.
Crystal oscillator input/output pin ^{*1}	XIN ^{*3}	I	This is the pin to connect the crystal oscillator.
	XOUT ^{*3}	O	
Power on reset input pin	PRST#	I	When this pin becomes low level, it will be in the power on reset state.
OSC drive capacity setting pin 0	MD_OSCDRV0	I	This is a pin for adjusting the drive capacity of the OSC buffer.
OSC drive capacity setting pin 1	MD_OSCDRV1	I	This is a pin for adjusting the drive capacity of the OSC buffer.

Note 1. When using a crystal oscillator, fix the pins of MD_OSCDRV0 and MD_OSCDRV1 to Low Level. Also, refer to the C/R constraints and implementation precautions described in the PCB design checklist.

Note 2. When using crystal oscillation, fix the EXCLK pin externally to Low Level.

Note 3. When using the clock from the outside without using the crystal oscillator, set the XIN pin to the external low level fixing process and the XOUT pin to Open.

7.1.4 Clock

7.1.4.1 Clock System Diagram

Figure 7.2 and Figure 7.3 show the clock system diagram.

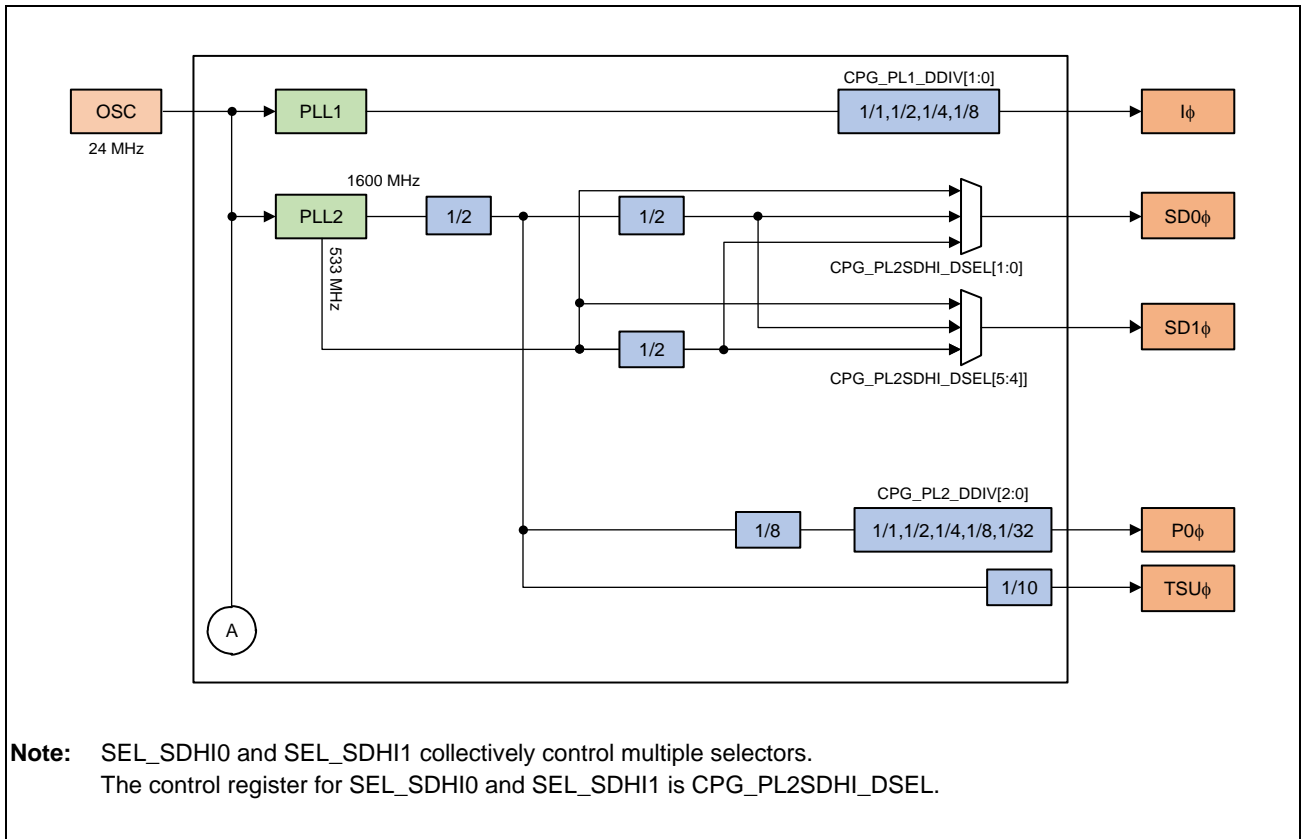

Figure 7.2 Clock System Diagram (1)

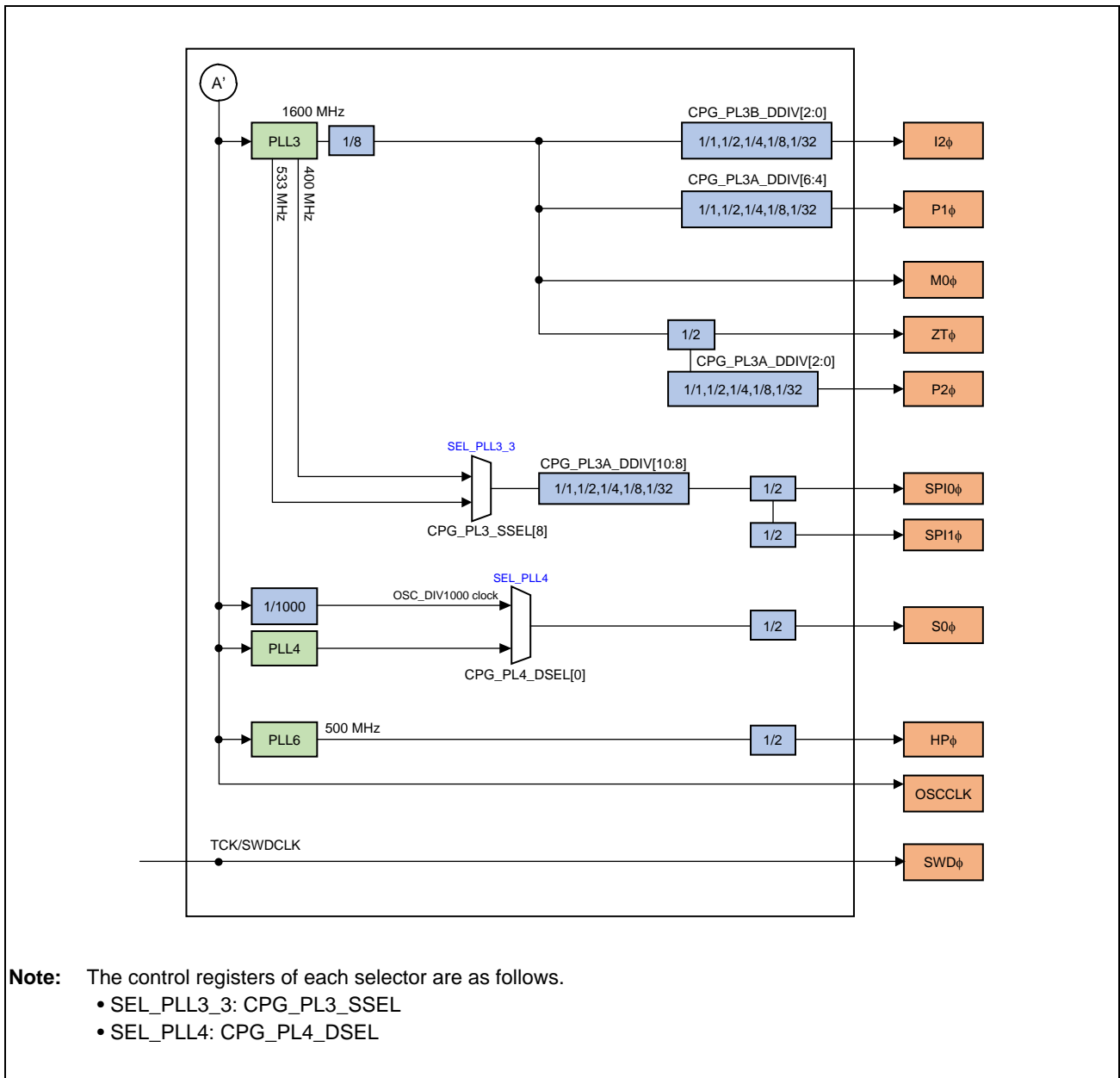



Figure 7.3 Clock System Diagram (2)

7.1.4.2 Clock List

Please refer to another file for the clock list. (Please double-click the icon on the right side) 

7.2 Register description

7.2.1 Register attributes

The following table shows the register attributes described in Register Details.

Table 7.3 Register attributes

Register attributes	Description
RW	A register that can be read and written.
RW0	A register that can read and 0b write. 1b Write is invalid.
RW1	A register that can read and 1b write. 0b Write is invalid.
R0W	It is a register that can be written with 0b Read at all times.
R1W	It is a register that can be written with 1b Read at all times.
R	A register that can read. Write is invalid.
R0W0	It is a register that can always read 0b and write 0b. 1b Write is invalid.
R0W1	It is a register that can always read 0b and write 1b. 0b Write is invalid.
R1W0	It is a register that can always read 1b and write 0b. 1b Write is invalid.
R1W1	It is a register that can always read 1b and write 1b. 0b Write is invalid.
RCW0	A register that can be cleared by Read and 0b Write is possible. 1b Write is invalid.
RCW1	A register that can be cleared by Read and 1b Write is possible. 0b Write is invalid.

Note: This LSI does not guarantee the access result to the Reserved bit area and the undefined bit area. At the same time, the Reserved bit area and undefined area may have values other than the initial value "0". We do not guarantee the result of changing these values.

7.2.2 Register classification

The table below shows the general classification of the register space in this module.

The address of the CPG register is represented by an offset address from the CPG-based address.

The CPG-based address is H'0_1101_0000.

Table 7.4 Register Address space

Classification	Offset Address
SSCG PLL Control Registers (PLL1, 4, 6)	H'000 - H'0FF
Fast PLL Control Registers (PLL2, 3)	H'100 - H'17F
Reserved	H'180 - H'1FF
Frequency Dynamic Change Control Registers	H'200 - H'3FF
Frequency Static Change Control Registers	H'400 - H'4FF
Clock Control Registers	H'500 - H'67F
Clock Monitor Registers	H'680 - H'7FF
Reset Control Registers	H'800 - H'97F
Reset Monitor Registers	H'980 - H'AFF
Other Registers	H'B00 - H'FFF

7.2.3 Register configuration

Table 7.5 Register list (1/4)

Register Name	Abbreviation	R/W	Initial value*1	Address*2	Access Size
PLL1 (SSCG) Standby Control Register	CPG_SAMPPLL1_STBY	RW	H'0000 0005	H'000	32
PLL4 (SSCG) Standby Control Register	CPG_SAMPPLL4_STBY	RW	H'0000 0004	H'010	32
PLL6 (SSCG) Standby Control Register	CPG_SAMPPLL6_STBY	RW	H'0000 0000	H'020	32
PLL1 (SSCG) Output Clock Setting Register 1	CPG_SAMPPLL1_CLK1	RW	H'0000 3E83	H'004	32
PLL4 (SSCG) Output Clock Setting Register 1	CPG_SAMPPLL4_CLK1	RW	H'0000 3203	H'014	32
PLL6 (SSCG) Output Clock Setting Register 1	CPG_SAMPPLL6_CLK1	RW	H'0000 3E83	H'024	32
PLL1 (SSCG) Output Clock Setting Register 2	CPG_SAMPPLL1_CLK2	RW	H'0008 2D01	H'008	32
PLL4 (SSCG) Output Clock Setting Register 2	CPG_SAMPPLL4_CLK2	RW	H'0008 2400	H'018	32
PLL6 (SSCG) Output Clock Setting Register 2	CPG_SAMPPLL6_CLK2	RW	H'0008 2D02	H'028	32
PLL1 (SSCG) Monitor Register	CPG_SAMPPLL1_MON	R	H'0000 0011	H'00C	32
PLL4 (SSCG) Monitor Register	CPG_SAMPPLL4_MON	R	H'0000 0000	H'01C	32
PLL6 (SSCG) Monitor Register	CPG_SAMPPLL6_MON	R	H'0000 0000	H'02C	32
PLL1_SEL_SETTING Register	CPG_PLL1_SETTING	RW	H'0000 0001	H'040	32
CPG_OTPPLL0_MON Register	CPG_OTPPLL0_MON	R	H'xxxx xxxx	H'044	32
CPG_OTPPLL1_MON Register	CPG_OTPPLL1_MON	R	H'xxxx xxxx	H'048	32
CPG_OTPPLL2_MON Register	CPG_OTPPLL2_MON	R	H'xxxx xxxx	H'04C	32
PLL2(SSCG) Monitor Register	CPG_SIPLL2_MON	R	H'0000 0011	H'11C	32
PLL3(SSCG) Monitor Register	CPG_SIPLL3_MON	R	H'0000 0011	H'13C	32
Division Ratio Setting (PLL1) Register	CPG_PL1_DDIV	RW	H'0000 000x	H'200	32
Division Ratio Setting (PLL2) Register	CPG_PL2_DDIV	RW	H'0000 0000	H'204	32
Division Ratio Setting (PLL3A) Register	CPG_PL3A_DDIV	RW	H'0000 0000	H'208	32
Division Ratio Setting (PLL3B) Register	CPG_PL3B_DDIV	RW	H'0000 0000	H'20C	32
Source Clock Setting (SDHI) Register	CPG_PL2SDHI_DSEL	RW	H'0000 0011	H'218	32
Source Clock Setting (DDR) Register	CPG_PL4_DSEL	RW	H'0000 0000	H'21C	32
Clock Status Monitor Register	CPG_CLKSTATUS	R	H'0000 0000	H'280	32
Source Clock Setting Register	CPG_PL3_SSEL	RW	H'0000 0111	H'408	32
Clock Control Register ACPU	CPG_CLKON_SRAM_ACPU	RW	H'0000 0001	H'508	32
Clock Control Register MCPU	CPG_CLKON_SRAM_MCPU	RW	H'0000 0001	H'50C	32
Clock Control Register IAX45	CPG_CLKON_IAX45	RW	H'0000 0003	H'518	32
Clock Control Register SYC	CPG_CLKON_SYC	RW	H'0000 0000	H'528	32
Clock Control Register DMAC_REG	CPG_CLKON_DAMC_REG	RW	H'0000 0000	H'52C	32
Clock Control Register GTM	CPG_CLKON_GTM	RW	H'0000 0001	H'534	32
Clock Control Register MTU	CPG_CLKON_MTU	RW	H'0000 0000	H'538	32
Clock Control Register POE3	CPG_CLKON_POE3	RW	H'0000 0000	H'53C	32
Clock Control Register WDT	CPG_CLKON_WDT	RW	H'0000 00C3	H'548	32
Clock Control Register DDR	CPG_CLKON_DDR	RW	H'0000 0000	H'54C	32
Clock Control Register SPI_MULTI	CPG_CLKON_SPI_MULTI	RW	H'0000 0000	H'550	32
Clock Control Register SDHI	CPG_CLKON_SDHI	RW	H'0000 0000	H'554	32
Clock Control Register SSI	CPG_CLKON_SSI	RW	H'0000 0000	H'570	32
Clock Control Register USB	CPG_CLKON_USB	RW	H'0000 0000	H'578	32
Clock Control Register ETH	CPG_CLKON_ETH	RW	H'0000 0000	H'57C	32
Clock Control Register I2C	CPG_CLKON_I2C	RW	H'0000 0000	H'580	32

Table 7.5 Register list (2/4)

Register Name	Abbreviation	R/W	Initial value*1	Address*2	Access Size
Clock Control Register SCIF	CPG_CLKON_SCIF	RW	H'0000 0000	H'584	32
Clock Control Register SCI	CPG_CLKON_SCI	RW	H'0000 0000	H'588	32
Clock Control Register IRDA	CPG_CLKON_IRDA	RW	H'0000 0000	H'58C	32
Clock Control Register RSPI	CPG_CLKON_RSPI	RW	H'0000 0000	H'590	32
Clock Control Register CANFD	CPG_CLKON_CANFD	RW	H'0000 0000	H'594	32
Clock Control Register GPIO	CPG_CLKON_GPIO	RW	H'0000 0000	H'598	32
Clock Control Register ADC	CPG_CLKON_ADC	RW	H'0000 0000	H'5A8	32
Clock Control Register TSU	CPG_CLKON_TSU	RW	H'0000 0000	H'5AC	32
Clock Control Register AXI_TZCDDR	CPG_CLKON_AXI_TZCDDR	RW	H'0000 001F	H'5DC	32
Clock Control Register AX45MP	CPG_CLKON_AX45MP	RW	H'0000 0003	H'5F8	32
Clock Control Register NCEPLDM	CPG_CLKON_NCEPLDM	RW	H'0000 0003	H'600	32
Clock Control Register NCEPLMT	CPG_CLKON_NCEPLMT	RW	H'0000 0001	H'604	32
Clock Control Register NCEPLIC	CPG_CLKON_NCEPLIC	RW	H'0000 0001	H'608	32
Clock Monitor Register SRAM_ACPU	CPG_CLKMON_SRAM_ACPU	R	H'0000 0001	H'688	32
Clock Monitor Register SRAM_MCPU	CPG_CLKMON_SRAM_MCPU	R	H'0000 0001	H'68C	32
Clock Monitor Register IAX45	CPG_CLKMON_IAX45	R	H'0000 0003	H'698	32
Clock Monitor Register SYC	CPG_CLKMON_SYC	R	H'0000 0000	H'6A8	32
Clock Monitor Register DMAC_REG	CPG_CLKMON_DAMC_REG	R	H'0000 0000	H'6AC	32
Clock Monitor Register GTM	CPG_CLKMON_GTM	R	H'0000 0001	H'6B4	32
Clock Monitor Register MTU	CPG_CLKMON_MTU	R	H'0000 0000	H'6B8	32
Clock Monitor Register POE3	CPG_CLKMON_POE3	R	H'0000 0000	H'6BC	32
Clock Monitor Register WDT	CPG_CLKMON_WDT	R	H'0000 00C3	H'6C8	32
Clock Monitor Register DDR	CPG_CLKMON_DDR	R	H'0000 0000	H'6CC	32
Clock Monitor Register SPI_MULTI	CPG_CLKMON_SPI_MULTI	R	H'0000 0000	H'6D0	32
Clock Monitor Register SDHI	CPG_CLKMON_SDHI	R	H'0000 0000	H'6D4	32
Clock Monitor Register SSI	CPG_CLKMON_SSI	R	H'0000 0000	H'6F0	32
Clock Monitor Register USB	CPG_CLKMON_USB	R	H'0000 0000	H'6F8	32
Clock Monitor Register ETH	CPG_CLKMON_ETH	R	H'0000 0000	H'6FC	32
Clock Monitor Register I2C	CPG_CLKMON_I2C	R	H'0000 0000	H'700	32
Clock Monitor Register SCIF	CPG_CLKMON_SCIF	R	H'0000 0000	H'704	32
Clock Monitor Register SCI	CPG_CLKMON_SCI	R	H'0000 0000	H'708	32
Clock Monitor Register IRDA	CPG_CLKMON_IRDA	R	H'0000 0000	H'70C	32
Clock Monitor Register RSPI	CPG_CLKMON_RSPI	R	H'0000 0000	H'710	32
Clock Monitor Register CANFD	CPG_CLKMON_CANFD	R	H'0000 0000	H'714	32
Clock Monitor Register GPIO	CPG_CLKMON_GPIO	R	H'0000 0000	H'718	32
Clock Monitor Register ADC	CPG_CLKMON_ADC	R	H'0000 0000	H'728	32
Clock Monitor Register AX45MP	CPG_CLKMON_AX45MP	R	H'0000 0003	H'778	32
Clock Monitor Register NCEPLDM	CPG_CLKMON_NCEPLDM	R	H'0000 0002	H'780	32
Clock Monitor Register NCEPLMT	CPG_CLKMON_NCEPLMT	R	H'0000 0001	H'784	32
Clock Monitor Register NCEPLIC	CPG_CLKMON_NCEPLIC	R	H'0000 0001	H'788	32
Clock Monitor Register TSU	CPG_CLKMON_TSU	R	H'0000 0000	H'72C	32
Clock Monitor Register AXI_TZCDDR	CPG_CLKMON_AXI_TZCDDR	R	H'0000 0007	H'75C	32
Reset Control Register SRAM_ACPU	CPG_RST_SRAM_ACPU	RW	H'0000 0001	H'808	32
Reset Control Register SRAM_MCPU	CPG_RST_SRAM_MCPU	RW	H'0000 0001	H'80C	32
Reset Control Register IAX45	CPG_RST_IAX45	RW	H'0000 0001	H'818	32

Table 7.5 Register list (3/4)

Register Name	Abbreviation	R/W	Initial value*1	Address*2	Access Size
Reset Control Register SYC	CPG_RST_SYC	RW	H'0000 0000	H'828	32
Reset Control Register DMAC	CPG_RST_DMAC	RW	H'0000 0000	H'82C	32
Reset Control Register GTM	CPG_RST_GTM	RW	H'0000 0001	H'834	32
Reset Control Register MTU	CPG_RST_MTU	RW	H'0000 0000	H'838	32
Reset Control Register POE3	CPG_RST_POE3	RW	H'0000 0000	H'83C	32
Reset Control Register WDT	CPG_RST_WDT	RW	H'0000 0009	H'848	32
Reset Control Register DDR	CPG_RST_DDR	RW	H'0000 0000	H'84C	32
Reset Control Register SPI	CPG_RST_SPI	RW	H'0000 0000	H'850	32
Reset Control Register SDHI	CPG_RST_SDHI	RW	H'0000 0000	H'854	32
Reset Control Register SSIF	CPG_RST_SSIF	RW	H'0000 0000	H'870	32
Reset Control Register USB	CPG_RST_USB	RW	H'0000 0000	H'878	32
Reset Control Register ETH	CPG_RST_ETH	RW	H'0000 0000	H'87C	32
Reset Control Register I2C	CPG_RST_I2C	RW	H'0000 0000	H'880	32
Reset Control Register SCIF	CPG_RST_SCIF	RW	H'0000 0000	H'884	32
Reset Control Register SCI	CPG_RST_SCI	RW	H'0000 0000	H'888	32
Reset Control Register IRDA	CPG_RST_IRDA	RW	H'0000 0000	H'88C	32
Reset Control Register RSPI	CPG_RST_RSPI	RW	H'0000 0000	H'890	32
Reset Control Register CANFD	CPG_RST_CANFD	RW	H'0000 0000	H'894	32
Reset Control Register GPIO	CPG_RST_GPIO	RW	H'0000 0000	H'898	32
Reset Control Register ADC	CPG_RST_ADC	RW	H'0000 0000	H'8A8	32
Reset Control Register TSU	CPG_RST_TSU	RW	H'0000 0000	H'8AC	32
Reset Control Register AXI_TZCDDR	CPG_RST_AXI_TZCDDR	RW	H'0000 001F	H'8DC	32
Reset Control Register AX45MP	CPG_RST_AX45MP	RW	H'0000 000F	H'8F8	32
Reset Control Register NCEPLDM	CPG_RST_NCEPLDM	RW	H'0000 0003	H'900	32
Reset Control Register NCEPLMT	CPG_RST_NCEPLMT	RW	H'0000 0003	H'904	32
Reset Control Register NCEPLIC	CPG_RST_NCEPLIC	RW	H'0000 0001	H'908	32
Reset Monitor Register SRAM_ACPU	CPG_RSTMON_SRAM_ACPU	R	H'0000 0000	H'988	32
Reset Monitor Register SRAM_MCPU	CPG_RSTMON_SRAM_MCPU	R	H'0000 0000	H'98C	32
Reset Monitor Register IAX45	CPG_RSTMON_IAX45	R	H'0000 0000	H'998	32
Reset Monitor Register SYC	CPG_RSTMON_SYC	R	H'0000 0001	H'9A8	32
Reset Monitor Register DMAC	CPG_RSTMON_DMAC	R	H'0000 0003	H'9AC	32
Reset Monitor Register GTM	CPG_RSTMON_GTM	R	H'0000 0006	H'9B4	32
Reset Monitor Register MTU	CPG_RSTMON_MTU	R	H'0000 0001	H'9B8	32
Reset Monitor Register POE3	CPG_RSTMON_POE3	R	H'0000 0001	H'9BC	32
Reset Monitor Register WDT	CPG_RSTMON_WDT	R	H'0000 0006	H'9C8	32
Reset Monitor Register DDR	CPG_RSTMON_DDR	R	H'0000 007F	H'9CC	32
Reset Monitor Register SPI	CPG_RSTMON_SPI	R	H'0000 0001	H'9D0	32
Reset Monitor Register SDHI	CPG_RSTMON_SDHI	R	H'0000 0003	H'9D4	32
Reset Monitor Register SSIF	CPG_RSTMON_SSIF	R	H'0000 000F	H'9F0	32
Reset Monitor Register USB	CPG_RSTMON_USB	R	H'0000 000F	H'9F8	32
Reset Monitor Register ETH	CPG_RSTMON_ETH	R	H'0000 0003	H'9FC	32
Reset Monitor Register I2C	CPG_RSTMON_I2C	R	H'0000 000F	H'A00	32
Reset Monitor Register SCIF	CPG_RSTMON_SCIF	R	H'0000 001F	H'A04	32
Reset Monitor Register SCI	CPG_RSTMON_SCI	R	H'0000 0003	H'A08	32
Reset Monitor Register IRDA	CPG_RSTMON_IRDA	R	H'0000 0001	H'A0C	32

Table 7.5 Register list (4/4)

Register Name	Abbreviation	R/W	Initial value* ¹	Address* ²	Access Size
Reset Monitor Register RSPI	CPG_RSTMON_RSPI	R	H'0000 0007	H'A10	32
Reset Monitor Register CANFD	CPG_RSTMON_CANFD	R	H'0000 0003	H'A14	32
Reset Monitor Register GPIO	CPG_RSTMON_GPIO	R	H'0000 0007	H'A18	32
Reset Monitor Register ADC	CPG_RSTMON_ADC	R	H'0000 0003	H'A28	32
Reset Monitor Register TSU	CPG_RSTMON_TSU	R	H'0000 0001	H'A2C	32
Reset Monitor Register AXI_TZCDDR	CPG_RSTMON_AXI_TZCDDR	R	H'0000 0000	H'A5C	32
Reset Monitor Register AX45MP	CPG_RSTMON_AX45MP	R	H'0000 0000	H'A78	32
Reset Monitor Register NCEPLDM	CPG_RSTMON_NCEPLDM	R	H'0000 0000	H'A80	32
Reset Monitor Register NCEPLMT	CPG_RSTMON_NCEPLMT	R	H'0000 0000	H'A84	32
Reset Monitor Register NCEPLIC	CPG_RSTMON_NCEPLIC	R	H'0000 0000	H'A88	32
WDT Overflow System Reset Register	CPG_WDTOVF_RST	RW	H'0000 0000	H'B10	32
WDT Reset Selector Register	CPG_WDTRST_SEL	RW	H'0000 0088	H'B14	32
MSTOP Register ACPU	CPG_BUS_ACPU_MSTOP	RW	H'0000 0000	H'B60	32
MSTOP Register MCPU1	CPG_BUS_MCPU1_MSTOP	RW	H'0000 0000	H'B64	32
MSTOP Register MCPU2	CPG_BUS_MCPU2_MSTOP	RW	H'0000 0000	H'B68	32
MSTOP Register PERI_COM	CPG_BUS_PERI_COM_MSTO P	RW	H'0000 0000	H'B6C	32
MSTOP Register PERI_CPU	CPG_BUS_PERI_CPU_MSTO P	RW	H'0000 0000	H'B70	32
MSTOP Register PERI_DDR	CPG_BUS_PERI_DDR_MSTO P	RW	H'0000 0000	H'B74	32
MSTOP Register REG0	CPG_BUS_REG0_MSTOP	RW	H'0000 0000	H'B7C	32
MSTOP Register REG1	CPG_BUS_REG1_MSTOP	RW	H'0000 0000	H'B80	32
MSTOP Register TZCDDR	CPG_BUS_TZCDDR_MSTOP	RW	H'0000 0000	H'B84	32
Other Function Register 2	CPG_OTHERFUNC2_REG	RW	H'0000 0000	H'BEC	32
Clock Control Register MBUS	CPG_CLKON_MBUS	RW	H'0000 0FFF	H'5B8	32
Clock Monitor Register MBUS	CPG_CLKMON_MBUS	R	H'0000 0FFF	H'738	32

Note 1. **Initial value:** The reset is released according to the sequence of the system reset, and the initial value is the one immediately after the last reset release in the sequence.

Note 2. **Address:** The offset address from the base address.

7.2.4 Register Descriptions

7.2.4.1 PLLn (SSCG) Standby Control Register (CPG_SAMPLLn_STBY) (n = 1, 4, or 6)

This register is used to control the power-saving mode and standby state and enable or disable the SSCG.

Bit	31	30	29	28	27	26	25	24	23	22	21	20	19	18	17	16
	—	—	—	—	—	—	—	—	—	—	—	SSCG_MODE_WEN	—	SSCG_EN_WEN	—	RESETB_WEN
Initial Value n = 1	0	0	0	0	0	0	0	0	0	0	0	0	0	0	0	0
Initial Value n = 4	0	0	0	0	0	0	0	0	0	0	0	0	0	0	0	0
Initial Value n = 6	0	0	0	0	0	0	0	0	0	0	0	0	0	0	0	0
R/W	R	R	R	R	R	R	R	R	R	R	R	R0W1	R	R0W1	R	R0W1
Bit	15	14	13	12	11	10	9	8	7	6	5	4	3	2	1	0
	—	—	—	—	—	—	—	—	—	—	SSCG_MODE[1]	SSCG_MODE[0]	—	SSCG_EN	—	RESETB
Initial Value n = 1	0	0	0	0	0	0	0	0	0	0	0	0	0	1	0	1
Initial Value n = 4	0	0	0	0	0	0	0	0	0	0	0	0	0	1	0	0
Initial Value n = 6	0	0	0	0	0	0	0	0	0	0	0	0	0	0	0	0
R/W	R	R	R	R	R	R	R	R	R	R	RW	RW	R	RW	R	RW

Bit	Bit Name	Initial Value	R/W	Description
31 to 21	—	All 0	R	Reserved Whenever it is read, 0 is read. The written value will be ignored.
20	SSCG_MODE_WEN	0b	R0W1	Flag for enabling the writing to the SSCG_MODE[1:0] bits (bits 5 and 4) This bit is always read as 0. 0: Writing is disabled. 1: Writing is enabled.
19	—	0b	R	Reserved Whenever it is read, 0 is read. The written value will be ignored.
18	SSCG_EN_WEN	0b	R0W1	Flag for enabling the writing to the SSCG_EN bit (bit 2) This bit is always read as 0. 0: Writing is disabled. 1: Writing is enabled.
17	—	0b	R	Reserved Whenever it is read, 0 is read. The written value will be ignored.
16	RESETB_WEN	0b	R0W1	Flag for enabling the writing to the RESETB bit (bit 0) This bit is always read as 0. 0: Writing is disabled. 1: Writing is enabled.
15 to 6	—	All 0	R	Reserved Whenever it is read, 0 is read. The written value will be ignored.

Bit	Bit Name	Initial Value	R/W	Description
5, 4	SSCG_MODE[1:0]	00b	RW	SSCG center spread or down spread setting (see the mode setting table below.* ¹) When writing to these bits, set the SSCG_MODE_WEN bit to 1 at the same time. 00b: Down spread 01b: Setting prohibited 10b: Setting prohibited 11b: Setting prohibited
3	—	0b	R	Reserved Whenever it is read, 0 is read. The written value will be ignored.
2	SSCG_EN	n=1,4: 1b n=6: 0b	RW	SSCG enable or disable setting (see the mode setting table below.* ¹) When writing to this bit, set the SSCG_EN_WEN bit to 1 at the same time. 0: SSCG is disabled. 1: SSCG is enabled.
1	—	0b	R	Reserved Whenever it is read, 0 is read. The written value will be ignored.
0	RESETB	n=1: 1b n=4,6: 0b	RW	PLL reset setting (see the mode setting table below.* ¹) When writing to this bit, set the RESETB_WEN bit to 1 at the same time. 0: Reset state 1: Active state (PLL is released from the reset state.)

Note 1. Mode Setting Table

Mode	Bit Name		
	RESETB	SSCG_EN	SSCG_MODE[1:0]
Reset state	0	—	—
SSCG disabled	1	0	—
SSCG enabled Down spread		1	00b
Setting prohibited			11b

7.2.4.2 PLLn (SSCG) Output Clock Setting Register 1 (CPG_SAMPLLn_CLK1) (n = 1, 4, or 6)

This register is used to specify the frequency division values k, m, and p for SSCG PLLn (n = 1, 4, or 6).

Bit	31	30	29	28	27	26	25	24	23	22	21	20	19	18	17	16
	DIV_K															
Initial Value n = 1	0	0	0	0	0	0	0	0	0	0	0	0	0	0	0	0
Initial Value n = 4	0	0	0	0	0	0	0	0	0	0	0	0	0	0	0	0
Initial Value n = 6	0	0	0	0	0	0	0	0	0	0	0	0	0	0	0	0
R/W	RW	RW	RW	RW	RW	RW	RW	RW	RW	RW	RW	RW	RW	RW	RW	RW
Bit	15	14	13	12	11	10	9	8	7	6	5	4	3	2	1	0
	DIV_M										DIV_P					
Initial Value n = 1	0	0	1	1	1	1	1	0	1	0	0	0	0	0	1	1
Initial Value n = 4	0	0	1	1	0	0	1	0	0	0	0	0	0	0	1	1
Initial Value n = 6	0	0	1	1	1	1	1	0	1	0	0	0	0	0	1	1
R/W	RW	RW	RW	RW	RW	RW	RW	RW	RW	RW	RW	RW	RW	RW	RW	RW

Bit	Bit Name	Initial Value	R/W	Description
31 to 16	DIV_K	All 0	RW	Delta-sigma modulator (DSM) setting*4 Specify a 2's complement of a decimal value from -32,768 to 32,767 that satisfies the restrictions*1. 1000_0000_0000_0000b: k = -32,768 1000_0000_0000_0001b: k = -32,767 1000_0000_0000_0010b: k = -32,766 : 0111_1111_1111_1101b: k = +32,765 0111_1111_1111_1110b: k = +32,766 0111_1111_1111_1111b: k = +32,767
15 to 6	DIV_M	n = 1: 00_1111_1010b n = 4: 00_1100_1000b n = 6: 00_1111_1010b	RW	Main divider setting*4 Specify an unsigned binary value from 64 to 533 that satisfies the restrictions*1 *2. 11_1111_1111b to 10_0001_0110b (Division value m = 534): Setting prohibited 10_0001_0101b: Division value m = 533 10_0001_0100b: Division value m = 532 : 00_0100_0001b: Division value m = 65 00_0100_0000b: Division value m = 64 00_0011_1111b to 00_0000_0000b: Setting prohibited
5 to 0	DIV_P	'n = 1: 00_0011b 'n = 4: 00_0011b 'n = 6: 00_0011b	RW	Pre-divider setting*4 Specify a value from 1 to 8 that satisfies the restrictions*1 *2. 11_1111b to 00_00_0101b: Setting prohibited 00_0100b: Division value p = 4 (FFREF = 6 MHz) 00_0011b: Division value p = 3 (FFREF = 8 MHz) 00_0010b: Division value p = 2 (FFREF = 12 MHz) 00_0001b: Division value p = 1 (FFREF = 24 MHz) 00_0000b: Setting prohibited

Note 1. The PLL oscillation frequency (F_{FVCO}) and output frequency (F_{FOUT}) can be calculated by the following equations.

- Equations

$$F_{FVCO} = \frac{((m + k/65536) \times F_{Fin})}{p}$$

$$F_{Fout} = \frac{((m + k/65536) \times F_{Fin})^{*3}}{(p \times 2^s)}$$

- Restrictions

F_{Fin} : 24 MHz

$6 \text{ MHz} \leq F_{FREF} = F_{Fin}/p \leq 30 \text{ MHz}$

$1,125 \text{ MHz} \leq F_{FVCO} \leq 2,500 \text{ MHz}$

Note 2. Specify DIV_K, DIV_M, DIV_P, and DIV_S*³ within the allowable ranges of F_{FVCO} and F_{Fout} for each PLL shown below.

SSCG PLL	FFout Min.	Default FFout	Setting	FFout Max.
PLL1	1,000 MHz	1,000 MHz		1,000 MHz
PLL4	800 MHz	1,600 MHz		1,600 MHz
PLL6	100 MHz	500 MHz		500 MHz

Note 3. For DIV_S (value "s"), see **Section 7.2.4.3, PLLn (SSCG) Output Clock Setting Register 2 (CPG_SAMPn_CLK2) (n = 1, 4, or 6)**.

Note 4. The PLL should be reset after the PLL settings are modified. For details, refer to **Section 7.4.4, Procedures for PLL Setup**.

7.2.4.3 PLLn (SSCG) Output Clock Setting Register 2 (CPG_SAMPLLn_CLK2) (n = 1, 4, or 6)

This register is used to specify the frequency division value *s* and SSCG modulation values *mfr* and *mrr* for SSCG PLLn (n = 1, 4, or 6).

Bit	31	30	29	28	27	26	25	24	23	22	21	20	19	18	17	16
	—	—	—	—	—	—	—	—	MFR							
Initial Value n = 1	0	0	0	0	0	0	0	0	0	0	0	0	1	0	0	0
Initial Value n = 4	0	0	0	0	0	0	0	0	0	0	0	0	1	0	0	0
Initial Value n = 6	0	0	0	0	0	0	0	0	0	0	0	0	1	0	0	0
R/W	R	R	R	R	R	R	R	R	RW	RW	RW	RW	RW	RW	RW	RW
Bit	15	14	13	12	11	10	9	8	7	6	5	4	3	2	1	0
	—	—	MRR						—	—	—	—	—	DIV_S		
Initial Value n = 1	0	0	1	0	1	1	0	1	0	0	0	0	0	0	0	1
Initial Value n = 4	0	0	1	0	0	1	0	0	0	0	0	0	0	0	0	0
Initial Value n = 6	0	0	1	0	1	1	0	1	0	0	0	0	0	0	1	0
R/W	R	R	RW	RW	RW	RW	RW	RW	R	R	R	R	R	RW	RW	RW

Bit	Bit Name	Initial Value	R/W	Description
31 to 24	—	All 0	R	Reserved Whenever it is read, 0 is read. The written value will be ignored.
23 to 16	MFR	n = 1: H'08 n = 4: H'08 n = 6: H'08	RW	Modulation frequency setting The PLL should be reset after this setting is modified. For details, refer to Section 7.4.4, Procedures for PLL Setup . Specify a value from 0 to 255 (decimal).*1 1111_1111b: mfr = 255 1111_1110b: mfr = 254 : 0000_0001b: mfr = 1 0000_0000b: mfr = 0
15, 14	—	00b	R	Reserved Whenever it is read, 0 is read. The written value will be ignored.
13 to 8	MRR	'n = 1: 10_1101b 'n = 4: 10_0100b 'n = 6: 10_1101b	RW	Modulation ratio setting The PLL should be reset after this setting is modified. For details, refer to Section 7.4.4, Procedures for PLL Setup . Specify a value from 1 to 63 (decimal).*1 11_1111b: mrr = 63 11_1110b: mrr = 62 : 00_0010b: mrr = 2 00_0001b: mrr = 1 00_0000b: Setting prohibited
7 to 3	—	00000b	R	Reserved Whenever it is read, 0 is read. The written value will be ignored.

Bit	Bit Name	Initial Value	R/W	Description
2 to 0	DIV_S	'n = 1: 001b 'n = 4: 000b 'n = 6: 010b	RW	Divider s setting*2 Specify a value from 0 to 6 (decimal). 111b: Setting prohibited 110b: Division value s = 6 (Division ratio = 64) 101b: Division value s = 5 (Division ratio = 32) 100b: Division value s = 4 (Division ratio = 16) 011b: Division value s = 3 (Division ratio = 8) 010b: Division value s = 2 (Division ratio = 4) 001b: Division value s = 1 (Division ratio = 2) 000b: Division value s = 0 (Division ratio = 1)

Note 1. The modulation frequency (MF) and modulation ratio (pk-pk) (MR) can be calculated by the following equations.

- Equations

$$MF = \frac{(F_{Fin})}{p \times mfr \times (2^5)}$$

$$MR = \frac{mfr \times mrr}{m \times (2^6)} \times 100[\%]$$

- Restrictions

F_{Fin} : 24 MHz

0000_0000b ≤ MFR[7:0] ≤ 1111_1111b

00_0001b ≤ MRR[5:0] ≤ 11_1111b

0 ≤ mrr × mfr ≤ 512

Note 2. For DIV_M (value "m") and DIV_P (value "p"), see **Section 7.2.4.2, PLLn (SSCG) Output Clock Setting Register 1 (CPG_SAMPLLn_CLK1) (n = 1, 4, or 6)**.

Important:

For the procedures for setting up the PLL, see **Section 7.4.4, Procedures for PLL Setup**.

Initial Values:

The initial values of the registers for PLL1, PLL4, and PLL6 and output clocks are shown below.

- Initial values of registers

PLL	CPG_SAMPLL _n _STBY (n = 1, 4, or 6)		
	SSCG_MODE	SSCG_EN	RESETB
	Bits 5 and 4	Bit 2	Bit 0
PLL1	H'0 (Down spread)	1 (SSCG is enabled)	1 (Released from the reset state)
PLL4	H'0 (Down spread)	1 (SSCG is enabled)	0 (Reset state)
PLL6	H'0 (Down spread)	0 (SSCG is disabled)	0 (Reset state)

PLL	CPG_SAMPLL _n _CLK1 (n = 1, 4, or 6)			CPG_SAMPLL _n _CLK2 (n = 1, 4, or 6)		
	DIV_K	DIV_M	DIV_P	DIV_S	MFR	MRR
	Bits 31 to 16	Bits 15 to 6	Bits 5 to 0	Bits 2 to 0	Bits 23 to 16	Bits 13 to 8
PLL1	H'0000 (k = 0)	H'0FA (m = 250)	H'3 (p = 3)	H'1 (s = 1)	H'08 (mfr = 8)	H'2D (mrr = 45)
PLL4	H'0000 (k = 0)	H'0C8 (m = 200)	H'3 (p = 3)	H'0 (s = 0)	H'08 (mfr = 8)	H'24 (mrr = 36)
PLL6	H'0000 (k = 0)	H'0FA (m = 250)	H'3 (p = 3)	H'2 (s = 2)	H'08 (mfr = 8)	H'2D (mrr = 45)

- Output clocks (initial values)

PLL	PLL Operating Mode	Frequency (F _{Fout}) [MHz]	SSCG	Fmod [kHz]	Spread	Modulation Depth [%]
PLL1	Active state	1,000	Enabled	31.25	Down spread	2.25
PLL4	Reset state	1,600	Enabled	31.25	Down spread	2.25
PLL6	Reset state	500	Disabled	31.25	Down spread	2.25

7.2.4.4 PLLn (SSCG) Monitor Register (CPG_SAMPLLn_MON) (n = 1, 4, or 6)

This register is used to monitor the state of the SSCG PLLn (n = 1, 4, or 6).

Bit	31	30	29	28	27	26	25	24	23	22	21	20	19	18	17	16
	—	—	—	—	—	—	—	—	—	—	—	—	—	—	—	—
Initial Value n = 1	0	0	0	0	0	0	0	0	0	0	0	0	0	0	0	0
Initial Value n = 4	0	0	0	0	0	0	0	0	0	0	0	0	0	0	0	0
Initial Value n = 6	0	0	0	0	0	0	0	0	0	0	0	0	0	0	0	0
R/W	R	R	R	R	R	R	R	R	R	R	R	R	R	R	R	R
Bit	15	14	13	12	11	10	9	8	7	6	5	4	3	2	1	0
	—	—	—	—	—	—	—	—	—	—	—	PLLn_L OCK	—	—	—	PLLn_R ESETB
Initial Value n = 1	0	0	0	0	0	0	0	0	0	0	0	1	0	0	0	1
Initial Value n = 4	0	0	0	0	0	0	0	0	0	0	0	0	0	0	0	0
Initial Value n = 6	0	0	0	0	0	0	0	0	0	0	0	0	0	0	0	0
R/W	R	R	R	R	R	R	R	R	R	R	R	R	R	R	R	R

Bit	Bit Name	Initial Value	R/W	Description
31 to 5	—	All 0	R	Reserved Whenever it is read, 0 is read. The written value will be ignored.
4	PLLn_LOCK	n = 1: 1b n = 4: 0b n = 6: 0b	R	SSCG PLL lock state monitoring 0: PLL is not locked. 1: PLL is locked.
3 to 1	—	000b	R	Reserved Whenever it is read, 0 is read. The written value will be ignored.
0	PLLn_RESET B	n = 1: 1b n = 4: 0b n = 6: 0b	R	SSCG PLL operating mode monitoring 1: Normal mode 0: Reset state (standby mode)

7.2.4.5 PLL1_SEL_SETTING Register (CPG_PLL1_SETTING)

This register is used to specify the frequency of PLL1.

Bit	31	30	29	28	27	26	25	24	23	22	21	20	19	18	17	16
	—	—	—	—	—	—	—	—	—	—	—	—	—	—	—	SEL_PL L1_W EN
Initial Value	0	0	0	0	0	0	0	0	0	0	0	0	0	0	0	0
R/W	R	R	R	R	R	R	R	R	R	R	R	R	R	R	R	R0W1
Bit	15	14	13	12	11	10	9	8	7	6	5	4	3	2	1	0
	—	—	—	—	—	—	—	—	—	—	—	—	—	—	—	SEL_PL L1
Initial Value	0	0	0	0	0	0	0	0	0	0	0	0	0	0	0	1
R/W	R	R	R	R	R	R	R	R	R	R	R	R	R	R	R	RW

Bit	Bit Name	Initial Value	R/W	Description
31 to 17	—	All 0	R	Reserved Whenever it is read, 0 is read. The written value will be ignored.
16	SEL_PLL1_W EN	0b	R0W1	Flag for enabling the writing to the SEL_PLL1 bit. This bit is always read as 0. 0: Writing is disabled. 1: Writing is enabled.
15 to 1	—	All 0	R	Reserved Whenever it is read, 0 is read. The written value will be ignored.
0	SEL_PLL1	1b	RW	The PLL multiplication factor is specified. 0: PLL1 operates according to the settings in the PLL1 SYSREG of the CPG. 1: When bit 0 of OTP_OTPPLL0 is 1, PLL1 operates according to the settings of OTP_OTPPLL0 to OTP_OTPPLL2. When bit 0 of OTP_OTPPLL0 is 0, PLL1 operates according to the settings in the PLL1 SYSREG of the CPG.

7.2.4.6 CPG_OTPPLL0_MON Register (CPG_OTPPLL0_MON)

This register indicates the state of the OTP_OTPPLL0[31:0] pins of the CPG.

Bit	31	30	29	28	27	26	25	24	23	22	21	20	19	18	17	16
	OTP31_MON	OTP30_MON	OTP29_MON	OTP28_MON	OTP27_MON	OTP26_MON	OTP25_MON	OTP24_MON	OTP23_MON	OTP22_MON	OTP21_MON	OTP20_MON	OTP19_MON	OTP18_MON	OTP17_MON	OTP16_MON
Initial Value	—	—	—	—	—	—	—	—	—	—	—	—	—	—	—	—
R/W	R	R	R	R	R	R	R	R	R	R	R	R	R	R	R	R
Bit	15	14	13	12	11	10	9	8	7	6	5	4	3	2	1	0
	OTP15_MON	OTP14_MON	OTP13_MON	OTP12_MON	OTP11_MON	OTP10_MON	OTP9_MON	OTP8_MON	OTP7_MON	OTP6_MON	OTP5_MON	OTP4_MON	OTP3_MON	OTP2_MON	OTP1_MON	OTP0_MON
Initial Value	—	—	—	—	—	—	—	—	—	—	—	—	—	—	—	—
R/W	R	R	R	R	R	R	R	R	R	R	R	R	R	R	R	R

Bit	Bit Name	Initial Value	R/W	Description
31 to 0	OTPN_MON [n = 31 to 0]	—	R	These bits indicate the state of the OTP_OTPPLL0[31:0] pins of the CPG. <i>Note:</i> The values specified in the OTP are set in these bits as the initial values.

7.2.4.7 CPG_OTPPLL1_MON Register (CPG_OTPPLL1_MON)

This register indicates the state of the OTP_OTPPLL1[31:0] pins of the CPG.

Bit	31	30	29	28	27	26	25	24	23	22	21	20	19	18	17	16
	OTP31_MON	OTP30_MON	OTP29_MON	OTP28_MON	OTP27_MON	OTP26_MON	OTP25_MON	OTP24_MON	OTP23_MON	OTP22_MON	OTP21_MON	OTP20_MON	OTP19_MON	OTP18_MON	OTP17_MON	OTP16_MON
Initial Value	—	—	—	—	—	—	—	—	—	—	—	—	—	—	—	—
R/W	R	R	R	R	R	R	R	R	R	R	R	R	R	R	R	R
Bit	15	14	13	12	11	10	9	8	7	6	5	4	3	2	1	0
	OTP15_MON	OTP14_MON	OTP13_MON	OTP12_MON	OTP11_MON	OTP10_MON	OTP9_MON	OTP8_MON	OTP7_MON	OTP6_MON	OTP5_MON	OTP4_MON	OTP3_MON	OTP2_MON	OTP1_MON	OTP0_MON
Initial Value	—	—	—	—	—	—	—	—	—	—	—	—	—	—	—	—
R/W	R	R	R	R	R	R	R	R	R	R	R	R	R	R	R	R

Bit	Bit Name	Initial Value	R/W	Description
31 to 0	OTPN_MON [n = 31 to 0]	—	R	These bits indicate the state of the OTP_OTPPLL1[31:0] pins of the CPG. <i>Note:</i> The values specified in the OTP are set in these bits as the initial values.

7.2.4.8 CPG_OTPPLL2_MON Register (CPG_OTPPLL2_MON)

This register indicates the state of the OTP_OTPPLL2[31:0] pins of the CPG.

Bit	31	30	29	28	27	26	25	24	23	22	21	20	19	18	17	16
	OTP31_MON	OTP30_MON	OTP29_MON	OTP28_MON	OTP27_MON	OTP26_MON	OTP25_MON	OTP24_MON	OTP23_MON	OTP22_MON	OTP21_MON	OTP20_MON	OTP19_MON	OTP18_MON	OTP17_MON	OTP16_MON
Initial Value	—	—	—	—	—	—	—	—	—	—	—	—	—	—	—	—
R/W	R	R	R	R	R	R	R	R	R	R	R	R	R	R	R	R
Bit	15	14	13	12	11	10	9	8	7	6	5	4	3	2	1	0
	OTP15_MON	OTP14_MON	OTP13_MON	OTP12_MON	OTP11_MON	OTP10_MON	OTP9_MON	OTP8_MON	OTP7_MON	OTP6_MON	OTP5_MON	OTP4_MON	OTP3_MON	OTP2_MON	OTP1_MON	OTP0_MON
Initial Value	—	—	—	—	—	—	—	—	—	—	—	—	—	—	—	—
R/W	R	R	R	R	R	R	R	R	R	R	R	R	R	R	R	R

Bit	Bit Name	Initial Value	R/W	Description
31 to 0	OTPN_MON [n = 31 to 0]	—	R	These bits indicate the state of the OTP_OTPPLL2[31:0] pins of the CPG. <i>Note:</i> The values specified in the OTP are set in these bits as the initial values.

7.2.4.9 PLLn (SSCG) Monitor Register (CPG_SIPLLn_MON) (n = 2, 3)

This register is used to monitor the state of the SSCG PLLn (n = 2, 3).

Bit	31	30	29	28	27	26	25	24	23	22	21	20	19	18	17	16
	—	—	—	—	—	—	—	—	—	—	—	—	—	—	—	—
Initial Value n = 2	0	0	0	0	0	0	0	0	0	0	0	0	0	0	0	0
Initial Value n = 3	0	0	0	0	0	0	0	0	0	0	0	0	0	0	0	0
R/W	R	R	R	R	R	R	R	R	R	R	R	R	R	R	R	R
Bit	15	14	13	12	11	10	9	8	7	6	5	4	3	2	1	0
	—	—	—	—	—	—	—	—	—	—	—	PLLn_L OCK	—	—	—	PLLn_ RESET B
Initial Value n = 2	0	0	0	0	0	0	0	0	0	0	0	1	0	0	0	1
Initial Value n = 3	0	0	0	0	0	0	0	0	0	0	0	1	0	0	0	1
R/W	R	R	R	R	R	R	R	R	R	R	R	R	R	R	R	R

Bit	Bit Name	Initial Value	R/W	Description
31 to 5	—	All 0	R	Reserved Whenever it is read, 0 is read. The written value will be ignored.
4	PLLn_LOCK [n = 2, 3]	n = 2: 1b n = 3: 1b	R	SSCG PLL lock state monitoring 0: PLL is not locked. 1: PLL is locked.
3 to 1	—	000b	R	Reserved Whenever it is read, 0 is read. The written value will be ignored.
0	PLLn_RESET B [n = 2, 3]	n = 2: 1b n = 3: 1b	R	SSCG PLL operating mode monitoring 1: Normal mode 0: Reset state (standby mode)

7.2.4.10 Division Ratio Setting (PLL1) Register (CPG_PL1_DDIV)

This register is used to set the division ratio of the clock for the AX45MP.

The PLL1 (1,000 MHz) output is used as the source clock.

The setting of this register can be dynamically modified while the clock is operating.

Bit	31	30	29	28	27	26	25	24	23	22	21	20	19	18	17	16
	—	—	—	—	—	—	—	—	—	—	—	—	—	—	—	DIV_PL L1SET_ WEN
Initial Value	0	0	0	0	0	0	0	0	0	0	0	0	0	0	0	0
R/W	R	R	R	R	R	R	R	R	R	R	R	R	R	R	R	R0W1
Bit	15	14	13	12	11	10	9	8	7	6	5	4	3	2	1	0
	—	—	—	—	—	—	—	—	—	—	—	—	—	—	—	DIVPL1_SET
Initial Value	0	0	0	0	0	0	0	0	0	0	0	0	0	0	0	0
R/W	R	R	R	R	R	R	R	R	R	R	R	R	R	R	RW	RW

Bit	Bit Name	Initial Value	R/W	Description
31 to 17	—	All 0	R	Reserved These bits are always read as 0. Writing to these bits is ignored.
16	DIV_PLL1SET_WEN	0b	R0W1	Flag for enabling the writing to the DIVPL1_SET bits This bit is always read as 0. 0: Writing is disabled. 1: Writing is enabled.
15 to 2	—	All 0	R	Reserved These bits are always read as 0. Writing to these bits is ignored.
1, 0	DIVPL1_SET	00b	RW	ϕ division ratio setting 00b: 1/1 (1,000MHz) 01b: 1/2 (500MHz) 10b: 1/4 (250MHz) 11b: 1/8 (125MHz)

7.2.4.11 Division Ratio Setting (PLL2) Register (CPG_PL2_DDIV)

This register is used to set the division ratios of the clocks for the system bus and the IP modules that cannot use SSCG clocks.

The PLL2 (up to 3,200 MHz) output is used as the source clock.

The setting of this register can be dynamically modified while the clock is operating.

Bit	31	30	29	28	27	26	25	24	23	22	21	20	19	18	17	16
	—	—	—	—	—	—	—	—	—	—	—	—	—	—	—	DIV_PL L2_A_W EN
Initial Value	0	0	0	0	0	0	0	0	0	0	0	0	0	0	0	0
R/W	R	R	R	R	R	R	R	R	R	R	R	R	R	R	R	R0W1
Bit	15	14	13	12	11	10	9	8	7	6	5	4	3	2	1	0
	—	—	—	—	—	—	—	—	—	—	—	—	—	DIVPL2A_SET		
Initial Value	0	0	0	0	0	0	0	0	0	0	0	0	0	0	0	0
R/W	R	R	R	R	R	R	R	R	R	R	R	R	R	RW	RW	RW

Bit	Bit Name	Initial Value	R/W	Description
31 to 29	—	000b	R	Reserved Whenever it is read, 0 is read. The written value will be ignored.
28	—	0b	R	Reserved When read, the initial value is read. When writing, be sure to write the initial value. Operation is not guaranteed if a value other than the initial value is written.
27 to 17	—	000b	R	Reserved Whenever it is read, 0 is read. The written value will be ignored.
16	DIV_PLL2_A_WEN	0b	R0W1	Flag for enabling the writing to the DIVPL2A_SET bits This bit is always read as 0. 0: Writing is disabled. 1: Writing is enabled.
15, 14	—	00b	R	Reserved Whenever it is read, 0 is read. The written value will be ignored.
13, 12	—	00b	R	Reserved When read, the initial value is read. When writing, be sure to write the initial value. Operation is not guaranteed if a value other than the initial value is written.
11	—	0b	R	Reserved Whenever it is read, 0 is read. The written value will be ignored.
10 to 8	—	000b	R	Reserved When read, the initial value is read. When writing, be sure to write the initial value. Operation is not guaranteed if a value other than the initial value is written.
7	—	0b	R	Reserved Whenever it is read, 0 is read. The written value will be ignored.
6 to 4	—	000b	R	Reserved When read, the initial value is read. When writing, be sure to write the initial value. Operation is not guaranteed if a value other than the initial value is written.
3	—	0b	R	Reserved Whenever it is read, 0 is read. The written value will be ignored.

Bit	Bit Name	Initial Value	R/W	Description
2 to 0	DIVPL2A_SE T	000b	RW	P0 ϕ division ratio setting 000b: 1/1 (100MHz) 001b: 1/2 (50MHz) 010b: 1/4 (25MHz) 011b: 1/8 (12.5MHz) 100b: 1/32 (3.125MHz) Others: Setting prohibited

7.2.4.12 Division Ratio Setting (PLL3A) Register (CPG_PL3A_DDIV)

This register is used to set the division ratios of the clocks for the system bus and the IP modules that can use SSCG clocks.

The clock obtained by dividing the output of PLL3 is used as the source clock.

The setting of this register can be dynamically modified while the clock is operating.

Bit	31	30	29	28	27	26	25	24	23	22	21	20	19	18	17	16
	—	—	—	—	—	—	—	DIV_PLL3_C_WEN	—	—	—	DIV_PLL3_B_WEN	—	—	—	DIV_PLL3_A_WEN
Initial Value	0	0	0	0	0	0	0	0	0	0	0	0	0	0	0	0
R/W	R	R	R	R	R	R	R	R0W1	R	R	R	R0W1	R	R	R	R0W1
Bit	15	14	13	12	11	10	9	8	7	6	5	4	3	2	1	0
	—	—	—	—	—	DIVPL3C_SET			—	DIVPL3B_SET			—	DIVPL3A_SET		
Initial Value	0	0	0	0	0	0	0	0	0	0	0	0	0	0	0	0
R/W	R	R	R	R	R	RW	RW	RW	R	RW	RW	RW	R	RW	RW	RW

Bit	Bit Name	Initial Value	R/W	Description
31 to 25	—	All 0	R	Reserved Whenever it is read, 0 is read. The written value will be ignored.
24	DIV_PLL3_C_WEN	0b	R0W1	Flag for enabling the writing to the DIVPL3C_SET bits This bit is always read as 0. 0: Writing is disabled. 1: Writing is enabled.
23 to 21	—	000b	R	Reserved Whenever it is read, 0 is read. The written value will be ignored.
20	DIV_PLL3_B_WEN	0b	R0W1	Flag for enabling the writing to the DIVPL3B_SET bits This bit is always read as 0. 0: Writing is disabled. 1: Writing is enabled.
19 to 17	—	000b	R	Reserved Whenever it is read, 0 is read. The written value will be ignored.
16	DIV_PLL3_A_WEN	0b	R0W1	Flag for enabling the writing to the DIVPL3A_SET bits This bit is always read as 0. 0: Writing is disabled. 1: Writing is enabled.
15 to 11	—	All 0	R	Reserved Whenever it is read, 0 is read. The written value will be ignored.
10 to 8	DIVPL3C_SET	000b	RW	DIV_PLL3_C division ratio setting 000b: 1/1 (400/533MHz)*1 001b: 1/2 (200/266.5MHz)*1 010b: 1/4 (100/133.25MHz)*1 011b: 1/8 (50/66.625MHz)*1 100b: 1/32 (12.5/16.656MHz)*1 Others: Setting prohibited <i>Note 1.</i> (xx/yyMHz) The source clock for xx is 400MHz. The source clock for yy is 533MHz. Please select 400 MHz or 533MHz with CPG_PL3_SSEL Register. In the latter stage, SPI0φ is divided into 1/2 and SPI1φ is divided into 1/4

Bit	Bit Name	Initial Value	R/W	Description
7	—	0b	R	Reserved Whenever it is read, 0 is read. The written value will be ignored.
6 to 4	DIVPL3B_SE T	000b	RW	P1 ϕ division ratio setting The source clock uses a clock (200MHz) that is 1/8 of the output of PLL3 (1,600MHz). 000b: 1/1 (200MHz) 001b: 1/2 (100MHz) 010b: 1/4 (50MHz) 011b: 1/8 (25MHz) 100b: 1/32 (6.25MHz) Others: Setting prohibited
3	—	0b	R	Reserved Whenever it is read, 0 is read. The written value will be ignored.
2 to 0	DIVPL3A_SE T	000b	RW	P2 ϕ division ratio setting The source clock uses a clock (100MHz) that is 1/16 of the output of PLL3 (1,600MHz). 000b: 1/1 (100MHz) 001b: 1/2 (50MHz) 010b: 1/4 (25MHz) 011b: 1/8 (12.5MHz) 100b: 1/32 (3.125MHz) Others: Setting prohibited

7.2.4.13 Division Ratio Setting (PLL3B) Register (CPG_PL3B_DDIV)

The source clock uses a clock (200MHz) that is 1/8 of the output of PLL3 (1,600MHz).

The setting of this register can be dynamically modified while the clock is operating.

Bit	31	30	29	28	27	26	25	24	23	22	21	20	19	18	17	16	
	—															DIV_PL L3_CLK 200FIX_ WEN	
Initial Value	0	0	0	0	0	0	0	0	0	0	0	0	0	0	0	0	0
R/W	R	R	R	R	R	R	R	R	R	R	R	R	R	R	R	R	R0W1
Bit	15	14	13	12	11	10	9	8	7	6	5	4	3	2	1	0	
	—													DIVPL3CLK200FIX_SET			
Initial Value	0	0	0	0	0	0	0	0	0	0	0	0	0	0	0	0	
R/W	R	R	R	R	R	R	R	R	R	R	R	R	R	RW	RW	RW	

Bit	Bit Name	Initial Value	R/W	Description
31 to 17	—	All 0	R	Reserved Whenever it is read, 0 is read. The written value will be ignored.
16	DIV_PLL3_CLK200FIX_WEN	0b	R0W1	Flag for enabling the writing to the DIVPL3CLK200FIX_SET bits This bit is always read as 0. 0: Writing is disabled. 1: Writing is enabled.
15 to 3	—	All 0	R	Reserved Whenever it is read, 0 is read. The written value will be ignored.
2 to 0	DIVPL3CLK200FIX_SET	000b	RW	l2φ division ratio setting 000b: 1/1 (200MHz) 001b: 1/2 (100MHz) 010b: 1/4 (50MHz) 011b: 1/8 (25MHz) 100b: 1/32 (6.25MHz) Others: Setting prohibited

7.2.4.14 Source Clock Setting (SDHI) Register (CPG_PL2SDHI_DSEL)

This register is used to switch the clocks for the SDHI.

The setting of this register can be dynamically modified while the clock is operating.

Bit	31	30	29	28	27	26	25	24	23	22	21	20	19	18	17	16
	—	—	—	—	—	—	—	—	—	—	—	SEL_SDHI1_WEN	—	—	—	SEL_SDHI0_WEN
Initial Value	0	0	0	0	0	0	0	0	0	0	0	0	0	0	0	0
R/W	R	R	R	R	R	R	R	R	R	R	R	R0W1	R	R	R	R0W1
Bit	15	14	13	12	11	10	9	8	7	6	5	4	3	2	1	0
	—	—	—	—	—	—	—	—	—	—	SEL_SDHI1_SET	—	—	—	SEL_SDHI0_SET	
Initial Value	0	0	0	0	0	0	0	0	0	0	0	1	0	0	0	1
R/W	R	R	R	R	R	R	R	R	R	R	RW	RW	R	R	RW	RW

Bit	Bit Name	Initial Value	R/W	Description
31 to 21	—	All 0	R	Reserved Whenever it is read, 0 is read. The written value will be ignored.
20	SEL_SDHI1_WEN	0b	R0W1	Flag for enabling the writing to the SEL_SDHI1_SET bits This bit is always read as 0. 0: Writing is disabled. 1: Writing is enabled.
19 to 17	—	All 0	R	Reserved Whenever it is read, 0 is read. The written value will be ignored.
16	SEL_SDHI0_WEN	0b	R0W1	Flag for enabling the writing to the SEL_SDHI0_SET bits This bit is always read as 0. 0: Writing is disabled. 1: Writing is enabled.
15 to 6	—	All 0	R	Reserved Whenever it is read, 0 is read. The written value will be ignored.
5, 4	SEL_SDHI1_SET	01b	RW	SEL_SDHI1 clock switching*1 00b: Setting prohibited 01b: 533 MHz 10b: 400 MHz 11b: 266 MHz
3, 2	—	All 0	R	Reserved Whenever it is read, 0 is read. The written value will be ignored.
1, 0	SEL_SDHI0_SET	01b	RW	SEL_SDHI0 clock switching*1 00b: Setting prohibited 01b: 533 MHz 10b: 400 MHz 11b: 266 MHz

Note: When 1 is written to the SEL_SDHI1_WEN or SEL_SDHI0_WEN bit placed in the upper 16 bits of this register, the clock switching control begins even if the settings in the lower bits are not changed. Check the status monitor register and wait until the switching is completed. The clock will temporarily stop at the timing of switching.

Note 1. To change the setting from 01b (533 MHz) to 10b (400 MHz) or vice versa, do not directly switch to the target clock. Switch to 11b (266 MHz) first, and then switch to the target setting (01b (533 MHz) or 10b (400 MHz)). Switching the clock directly between the above frequencies can temporarily generate pulses faster than 533MHz, which can cause malfunctions.

7.2.4.15 Source Clock Setting (DDR) Register (CPG_PL4_DSEL)

This register is used to switch the source clock for the DDR.

Bit	31	30	29	28	27	26	25	24	23	22	21	20	19	18	17	16
	—	—	—	—	—	—	—	—	—	—	—	—	—	—	—	SEL_PLL4_WEN
Initial Value	0	0	0	0	0	0	0	0	0	0	0	0	0	0	0	0
R/W	R	R	R	R	R	R	R	R	R	R	R	R	R	R	R	R0W1
Bit	15	14	13	12	11	10	9	8	7	6	5	4	3	2	1	0
	—	—	—	—	—	—	—	—	—	—	—	—	—	—	—	SEL_PLL4_SET
Initial Value	0	0	0	0	0	0	0	0	0	0	0	0	0	0	0	0
R/W	R	R	R	R	R	R	R	R	R	R	R	R	R	R	R	RW

Bit	Bit Name	Initial Value	R/W	Description
31 to 17	—	All 0	R	Reserved Whenever it is read, 0 is read. The written value will be ignored.
16	SEL_PLL4_WEN	0b	R0W1	Flag for enabling the writing to the SEL_PLL4_SET bit (bit 0) This bit is always read as 0. 0: Writing is disabled. 1: Writing is enabled.
15 to 1	—	All 0	R	Reserved Whenever it is read, 0 is read. The written value will be ignored.
0	SEL_PLL4_SET	0b	RW	Source clock setting 0: OSC_DIV1000 clock (0.024MHz) 1: PLL4 clock (1600MHz) <i>Note:</i> The clock selected by this register is halved in the latter stage. 0.024MHz / 2 = 0.012MHz 1600MHz / 2 = 800MHz S0φ = 0.012MHz or 800MHz

7.2.4.16 Clock Status Monitor Register (CPG_CLKSTATUS)

This register is used to monitor whether clock switching is completed in the dynamically modifiable frequency dividers and selectors.

Bit	31	30	29	28	27	26	25	24	23	22	21	20	19	18	17	16
	SELPLL4_ST S	—	SELSDHI1_ST S	SELSDHI0_ST S	—	—	—	—	—	—	—	—	—	—	—	—
Initial Value	0	0	0	0	0	0	0	0	0	0	0	0	0	0	0	0
R/W	R	R	R	R	R	R	R	R	R	R	R	R	R	R	R	R
Bit	15	14	13	12	11	10	9	8	7	6	5	4	3	2	1	0
	—	—	—	DIVPL3F_ST S	DIVPL3CLK200FIX_ST S	DIVPL3C_ST S	DIVPL3B_ST S	DIVPL3A_ST S	—	—	—	DIVPL2A_ST S	—	—	—	DIVPL1_ST S
Initial Value	0	0	0	0	0	0	0	0	0	0	0	0	0	0	0	0
R/W	R	R	R	R	R	R	R	R	R	R	R	R	R	R	R	R

Bit	Bit Name	Initial Value	R/W	Description
31	SELPLL4_ST S	0b	R	SELPLL4 clock switch completion state 0: Switching is completed. 1: Switching is not completed (busy).
30	—	0b	R	Reserved When read, the initial value is read. The written value will be ignored.
29	SELSDHI1_ST S	0b	R	SELSDHI1 clock switch completion state 0: Switching is completed. 1: Switching is not completed (busy).
28	SELSDHI0_ST S	0b	R	SELSDHI0 clock switch completion state 0: Switching is completed. 1: Switching is not completed (busy).
27 to 24	—	All 0	R	Reserved When read, the initial value is read. The written value will be ignored.
23 to 21	—	000b	R	Reserved When read, the initial value is read. The written value will be ignored.
20	—	0b	R	Reserved When read, the initial value is read. The written value will be ignored.
19 to 13	—	All 0	R	Reserved When read, the initial value is read. The written value will be ignored.
12	DIVPL3F_ST S	0b	R	DIVPL3F clock switch completion state 0: Switching is completed. 1: Switching is not completed (busy).
11	DIVPL3CLK200FIX_ST S	0b	R	DIVPL3CLK200FIX clock switch completion state 0: Switching is completed. 1: Switching is not completed (busy).
10	DIVPL3C_ST S	0b	R	DIVPL3C clock switch completion state 0: Switching is completed. 1: Switching is not completed (busy).
9	DIVPL3B_ST S	0b	R	DIVPL3B clock switch completion state 0: Switching is completed. 1: Switching is not completed (busy).

Bit	Bit Name	Initial Value	R/W	Description
8	DIVPL3A_STS	0b	R	DIVPL3A clock switch completion state 0: Switching is completed. 1: Switching is not completed (busy).
7	—	0b	R	Reserved When read, the initial value is read. The written value will be ignored.
6	—	0b	R	Reserved When read, the initial value is read. The written value will be ignored.
5	—	0b	R	Reserved When read, the initial value is read. The written value will be ignored.
4	DIVPL2A_STS	0b	R	DIVPL2A clock switch completion state 0: Switching is completed. 1: Switching is not completed (busy).
3 to 1	—	000b	R	Reserved When read, the initial value is read. The written value will be ignored.
0	DIVPL1_STS	0b	R	DIVPL1 clock switch completion state 0: Switching is completed. 1: Switching is not completed (busy).

7.2.4.17 Source Clock Setting Register (CPG_PL3_SSEL)

This register is used to switch the source clocks for the system bus and the IPs that can use SSCG clocks.

Bit	31	30	29	28	27	26	25	24	23	22	21	20	19	18	17	16
	—	—	—	—	—	—	—	SEL_PL L3_3_W EN	—	—	—	—	—	—	—	—
Initial Value	0	0	0	0	0	0	0	0	0	0	0	0	0	0	0	0
R/W	R	R	R	R	R	R	R	RW	R	R	R	R	R	R	R	R
Bit	15	14	13	12	11	10	9	8	7	6	5	4	3	2	1	0
	—	—	—	—	—	—	—	SEL_PL L3_3_S SET	—	—	—	—	—	—	—	—
Initial Value	0	0	0	0	0	0	0	1	0	0	0	1	0	0	0	1
R/W	R	R	R	R	R	R	R	RW	R	R	R	R	R	R	R	R

Bit	Bit Name	Initial Value	R/W	Description
31 to 25	—	All 0	R	Reserved Whenever it is read, 0 is read. The written value will be ignored.
24	SEL_PLL3_3_WEN	0b	RW	Flag for enabling the writing to the SEL_PLL3_3_SET bit (bit 8) This bit is always read as 0. 0: Writing is disabled. 1: Writing is enabled.
23 to 9	—	All 0	R	Reserved Whenever it is read, 0 is read. The written value will be ignored.
8	SEL_PLL3_3_SET	1b	RW	Source clock setting 0: 533MHz 1: 400MHz
7 to 5	—	000b	R	Reserved Whenever it is read, 0 is read. The written value will be ignored.
4	—	1b	R	Reserved When read, the initial value is read. When writing, be sure to write the initial value. Operation is not guaranteed if a value other than the initial value is written.
3 to 1	—	000b	R	Reserved Whenever it is read, 0 is read. The written value will be ignored.
0	—	1b	R	Reserved When read, the initial value is read. When writing, be sure to write the initial value. Operation is not guaranteed if a value other than the initial value is written.

7.2.4.18 Clock Control Register ACPU (CPG_CLKON_SRAM_ACPU)

This register is used to supply or stop clocks for individual modules.

Bit	31	30	29	28	27	26	25	24	23	22	21	20	19	18	17	16
	—	—	—	—	—	—	—	—	—	—	—	—	—	—	—	CLK0_ONWEN
Initial Value	0	0	0	0	0	0	0	0	0	0	0	0	0	0	0	0
R/W	R	R	R	R	R	R	R	R	R	R	R	R	R	R	R	R0W1
Bit	15	14	13	12	11	10	9	8	7	6	5	4	3	2	1	0
	—	—	—	—	—	—	—	—	—	—	—	—	—	—	—	CLK0_ON
Initial Value	0	0	0	0	0	0	0	0	0	0	0	0	0	0	0	1
R/W	R	R	R	R	R	R	R	R	R	R	R	R	R	R	R	RW

Bit	Bit Name	Initial Value	R/W	Description
31 to 17	—	All 0	R	Reserved Whenever it is read, 0 is read. The written value will be ignored.
16	CLK0_ONWEN	0b	R0W1	Flag for enabling the writing to the CLK0_ON bit (bit 0) This bit is always read as 0. 0: Writing is disabled. 1: Writing is enabled.
15 to 1	—	All 0	R	Reserved Whenever it is read, 0 is read. The written value will be ignored.
0	CLK0_ON	1b	RW	The SRAM_ACPU_ACLK clock is supplied or stopped. 0: Clock is stopped. 1: Clock is supplied.

7.2.4.19 Clock Control Register MCPU (CPG_CLKON_SRAM_MCPU)

This register is used to supply or stop clocks for individual modules.

Bit	31	30	29	28	27	26	25	24	23	22	21	20	19	18	17	16
	—	—	—	—	—	—	—	—	—	—	—	—	—	—	—	CLK0_ONWEN
Initial Value	0	0	0	0	0	0	0	0	0	0	0	0	0	0	0	0
R/W	R	R	R	R	R	R	R	R	R	R	R	R	R	R	R	R0W1
Bit	15	14	13	12	11	10	9	8	7	6	5	4	3	2	1	0
	—	—	—	—	—	—	—	—	—	—	—	—	—	—	—	CLK0_ON
Initial Value	0	0	0	0	0	0	0	0	0	0	0	0	0	0	0	1
R/W	R	R	R	R	R	R	R	R	R	R	R	R	R	R	R	RW

Bit	Bit Name	Initial Value	R/W	Description
31 to 17	—	All 0	R	Reserved Whenever it is read, 0 is read. The written value will be ignored.
16	CLK0_ONWEN	0b	R0W1	Flag for enabling the writing to the CLK0_ON bit (bit 0) This bit is always read as 0. 0: Writing is disabled. 1: Writing is enabled.
15 to 1	—	All 0	R	Reserved Whenever it is read, 0 is read. The written value will be ignored.
0	CLK0_ON	1b	RW	The SRAM_MCPU_ACLK clock is supplied or stopped. 0: Clock is stopped. 1: Clock is supplied.

7.2.4.20 Clock Control Register IAX45 (CPG_CLKON_IAX45)

This register is used to supply or stop clocks for individual modules.

Bit	31	30	29	28	27	26	25	24	23	22	21	20	19	18	17	16
	—	—	—	—	—	—	—	—	—	—	—	—	—	—	CLK1_ON NWEN	CLK0_ON NWEN
Initial Value	0	0	0	0	0	0	0	0	0	0	0	0	0	0	0	0
R/W	R	R	R	R	R	R	R	R	R	R	R	R	R	R	R0W1	R0W1
Bit	15	14	13	12	11	10	9	8	7	6	5	4	3	2	1	0
	—	—	—	—	—	—	—	—	—	—	—	—	—	—	CLK1_ON N	CLK0_ON N
Initial Value	0	0	0	0	0	0	0	0	0	0	0	0	0	0	1	1
R/W	R	R	R	R	R	R	R	R	R	R	R	R	R	R	RW	RW

Bit	Bit Name	Initial Value	R/W	Description
31 to 18	—	All 0	R	Reserved Whenever it is read, 0 is read. The written value will be ignored.
17	CLK1_ONWE N	0b	R0W1	Flag for enabling the writing to the CLK1_ON bit (bit 1) This bit is always read as 0. 0: Writing is disabled. 1: Writing is enabled.
16	CLK0_ONWE N	0b	R0W1	Flag for enabling the writing to the CLK0_ON bit (bit 0) This bit is always read as 0. 0: Writing is disabled. 1: Writing is enabled.
15 to 2	—	All 0	R	Reserved Whenever it is read, 0 is read. The written value will be ignored.
1	CLK1_ON	1b	RW	The IAX45_CLK clock is supplied or stopped. 0: Clock is stopped. 1: Clock is supplied.
0	CLK0_ON	1b	RW	The IAX45_PCLK clock is supplied or stopped. 0: Clock is stopped. 1: Clock is supplied.

7.2.4.21 Clock Control Register SYC (CPG_CLKON_SYC)

This register is used to supply or stop clocks for individual modules.

Bit	31	30	29	28	27	26	25	24	23	22	21	20	19	18	17	16
	—	—	—	—	—	—	—	—	—	—	—	—	—	—	—	CLK0_ONWEN
Initial Value	0	0	0	0	0	0	0	0	0	0	0	0	0	0	0	0
R/W	R	R	R	R	R	R	R	R	R	R	R	R	R	R	R	R0W1
Bit	15	14	13	12	11	10	9	8	7	6	5	4	3	2	1	0
	—	—	—	—	—	—	—	—	—	—	—	—	—	—	—	CLK0_ON
Initial Value	0	0	0	0	0	0	0	0	0	0	0	0	0	0	0	0
R/W	R	R	R	R	R	R	R	R	R	R	R	R	R	R	R	RW

Bit	Bit Name	Initial Value	R/W	Description
31 to 17	—	All 0	R	Reserved Whenever it is read, 0 is read. The written value will be ignored.
16	CLK0_ONWEN	0b	R0W1	Flag for enabling the writing to the CLK0_ON bit (bit 0) This bit is always read as 0. 0: Writing is disabled. 1: Writing is enabled.
15 to 1	—	All 0	R	Reserved Whenever it is read, 0 is read. The written value will be ignored.
0	CLK0_ON	0b	RW	The SYC_CNT_CLK clock is supplied or stopped. 0: Clock is stopped. 1: Clock is supplied.

7.2.4.22 Clock Control Register DMAC_REG (CPG_CLKON_DMACH_REG)

This register is used to supply or stop clocks for individual modules.

Bit	31	30	29	28	27	26	25	24	23	22	21	20	19	18	17	16
	—	—	—	—	—	—	—	—	—	—	—	—	—	—	CLK1_ON NWEN	CLK0_ON NWEN
Initial Value	0	0	0	0	0	0	0	0	0	0	0	0	0	0	0	0
R/W	R	R	R	R	R	R	R	R	R	R	R	R	R	R	R0W1	R0W1
Bit	15	14	13	12	11	10	9	8	7	6	5	4	3	2	1	0
	—	—	—	—	—	—	—	—	—	—	—	—	—	—	CLK1_ON N	CLK0_ON N
Initial Value	0	0	0	0	0	0	0	0	0	0	0	0	0	0	0	0
R/W	R	R	R	R	R	R	R	R	R	R	R	R	R	R	RW	RW

Bit	Bit Name	Initial Value	R/W	Description
31 to 18	—	All 0	R	Reserved Whenever it is read, 0 is read. The written value will be ignored.
17	CLK1_ONWE N	0b	R0W1	Flag for enabling the writing to the CLK1_ON bit (bit 1) This bit is always read as 0. 0: Writing is disabled. 1: Writing is enabled.
16	CLK0_ONWE N	0b	R0W1	Flag for enabling the writing to the CLK0_ON bit (bit 0) This bit is always read as 0. 0: Writing is disabled. 1: Writing is enabled.
15 to 2	—	All 0	R	Reserved Whenever it is read, 0 is read. The written value will be ignored.
1	CLK1_ON	0b	RW	The DMAC_PCLK clock is supplied or stopped. 0: Clock is stopped. 1: Clock is supplied.
0	CLK0_ON	0b	RW	The DMAC_ACLK clock is supplied or stopped. 0: Clock is stopped. 1: Clock is supplied.

7.2.4.23 Clock Control Register GTM (CPG_CLKON_GTM)

This register is used to supply or stop clocks for individual modules.

Bit	31	30	29	28	27	26	25	24	23	22	21	20	19	18	17	16
	—	—	—	—	—	—	—	—	—	—	—	—	—	CLK2_ON NWEN	CLK1_ON NWEN	CLK0_ON NWEN
Initial Value	0	0	0	0	0	0	0	0	0	0	0	0	0	0	0	0
R/W	R	R	R	R	R	R	R	R	R	R	R	R	R	R0W1	R0W1	R0W1
Bit	15	14	13	12	11	10	9	8	7	6	5	4	3	2	1	0
	—	—	—	—	—	—	—	—	—	—	—	—	—	CLK2_ON N	CLK1_ON N	CLK0_ON N
Initial Value	0	0	0	0	0	0	0	0	0	0	0	0	0	0	0	1
R/W	R	R	R	R	R	R	R	R	R	R	R	R	R	RW	RW	RW

Bit	Bit Name	Initial Value	R/W	Description
31 to 19	—	All 0	R	Reserved Whenever it is read, 0 is read. The written value will be ignored.
18	CLK2_ONWE N	0b	R0W1	Flag for enabling the writing to the CLK2_ON bit (bit 2) This bit is always read as 0. 0: Writing is disabled. 1: Writing is enabled.
17	CLK1_ONWE N	0b	R0W1	Flag for enabling the writing to the CLK1_ON bit (bit 1) This bit is always read as 0. 0: Writing is disabled. 1: Writing is enabled.
16	CLK0_ONWE N	0b	R0W1	Flag for enabling the writing to the CLK0_ON bit (bit 0) This bit is always read as 0. 0: Writing is disabled. 1: Writing is enabled.
15 to 3	—	All 0	R	Reserved Whenever it is read, 0 is read. The written value will be ignored.
2	CLK2_ON	0b	RW	The OSTM2_PCLK clock is supplied or stopped. 0: Clock is stopped. 1: Clock is supplied.
1	CLK1_ON	0b	RW	The OSTM1_PCLK clock is supplied or stopped. 0: Clock is stopped. 1: Clock is supplied.
0	CLK0_ON	1b	RW	The OSTM0_PCLK clock is supplied or stopped. 0: Clock is stopped. 1: Clock is supplied.

7.2.4.24 Clock Control Register MTU (CPG_CLKON_MTU)

This register is used to supply or stop clocks for individual modules.

Bit	31	30	29	28	27	26	25	24	23	22	21	20	19	18	17	16
	—	—	—	—	—	—	—	—	—	—	—	—	—	—	—	CLK0_ONWEN
Initial Value	0	0	0	0	0	0	0	0	0	0	0	0	0	0	0	0
R/W	R	R	R	R	R	R	R	R	R	R	R	R	R	R	R	R0W1
Bit	15	14	13	12	11	10	9	8	7	6	5	4	3	2	1	0
	—	—	—	—	—	—	—	—	—	—	—	—	—	—	—	CLK0_ON
Initial Value	0	0	0	0	0	0	0	0	0	0	0	0	0	0	0	0
R/W	R	R	R	R	R	R	R	R	R	R	R	R	R	R	R	RW

Bit	Bit Name	Initial Value	R/W	Description
31 to 17	—	All 0	R	Reserved Whenever it is read, 0 is read. The written value will be ignored.
16	CLK0_ONWEN	0b	R0W1	Flag for enabling the writing to the CLK0_ON bit (bit 0) This bit is always read as 0. 0: Writing is disabled. 1: Writing is enabled.
15 to 1	—	All 0	R	Reserved Whenever it is read, 0 is read. The written value will be ignored.
0	CLK0_ON	0b	RW	The MTU_X_MCK_MTU3 clock is supplied or stopped. 0: Clock is stopped. 1: Clock is supplied.

7.2.4.25 Clock Control Register POE3 (CPG_CLKON_POE3)

This register is used to supply or stop clocks for individual modules.

Bit	31	30	29	28	27	26	25	24	23	22	21	20	19	18	17	16
	—	—	—	—	—	—	—	—	—	—	—	—	—	—	—	CLK0_ONWEN
Initial Value	0	0	0	0	0	0	0	0	0	0	0	0	0	0	0	0
R/W	R	R	R	R	R	R	R	R	R	R	R	R	R	R	R	R0W1
Bit	15	14	13	12	11	10	9	8	7	6	5	4	3	2	1	0
	—	—	—	—	—	—	—	—	—	—	—	—	—	—	—	CLK0_ON
Initial Value	0	0	0	0	0	0	0	0	0	0	0	0	0	0	0	0
R/W	R	R	R	R	R	R	R	R	R	R	R	R	R	R	R	RW

Bit	Bit Name	Initial Value	R/W	Description
31 to 17	—	All 0	R	Reserved Whenever it is read, 0 is read. The written value will be ignored.
16	CLK0_ONWEN	0b	R0W1	Flag for enabling the writing to the CLK0_ON bit (bit 0) This bit is always read as 0. 0: Writing is disabled. 1: Writing is enabled.
15 to 1	—	All 0	R	Reserved Whenever it is read, 0 is read. The written value will be ignored.
0	CLK0_ON	0b	RW	The POE3_CLKM_POE clock is supplied or stopped. 0: Clock is stopped. 1: Clock is supplied.

7.2.4.26 Clock Control Register WDT (CPG_CLKON_WDT)

This register is used to supply or stop clocks for individual modules.

Bit	31	30	29	28	27	26	25	24	23	22	21	20	19	18	17	16
	—	—	—	—	—	—	—	—	—	—	—	—	—	—	CLK1_ON NWEN	CLK0_ON NWEN
Initial Value	0	0	0	0	0	0	0	0	0	0	0	0	0	0	0	0
R/W	R	R	R	R	R	R	R	R	R	R	R	R	R	R	R0W1	R0W1
Bit	15	14	13	12	11	10	9	8	7	6	5	4	3	2	1	0
	—	—	—	—	—	—	—	—	—	—	—	—	—	—	CLK1_ON N	CLK0_ON N
Initial Value	0	0	0	0	0	0	0	0	1	1	0	0	0	0	1	1
R/W	R	R	R	R	R	R	R	R	R	R	R	R	R	R	RW	RW

Bit	Bit Name	Initial Value	R/W	Description
31 to 22	—	All 0	R	Reserved Whenever it is read, 0 is read. The written value will be ignored.
21	—	0b	R	Reserved When read, the initial value is read. When writing, be sure to write the initial value. Operation is not guaranteed if a value other than the initial value is written.
20	—	0b	R	Reserved When read, the initial value is read. When writing, be sure to write the initial value. Operation is not guaranteed if a value other than the initial value is written.
19, 18	—	00b	R	Reserved When read, the initial value is read. When writing, be sure to write the initial value. Operation is not guaranteed if a value other than the initial value is written.
17	CLK1_ONWE N	0b	R0W1	Flag for enabling the writing to the CLK1_ON bit (bit 1) This bit is always read as 0. 0: Writing is disabled. 1: Writing is enabled.
16	CLK0_ONWE N	0b	R0W1	Flag for enabling the writing to the CLK0_ON bit (bit 0) This bit is always read as 0. 0: Writing is disabled. 1: Writing is enabled.
15 to 8	—	All 0	R	Reserved Whenever it is read, 0 is read. The written value will be ignored.
7	—	1b	R	Reserved When read, the initial value is read. When writing, be sure to write the initial value. Operation is not guaranteed if a value other than the initial value is written.
6	—	1b	R	Reserved When read, the initial value is read. When writing, be sure to write the initial value. Operation is not guaranteed if a value other than the initial value is written.
5	—	0b	R	Reserved When read, the initial value is read. When writing, be sure to write the initial value. Operation is not guaranteed if a value other than the initial value is written.
4	—	0b	R	Reserved When read, the initial value is read. When writing, be sure to write the initial value. Operation is not guaranteed if a value other than the initial value is written.
3, 2	—	00b	R	Reserved When read, the initial value is read. When writing, be sure to write the initial value. Operation is not guaranteed if a value other than the initial value is written.

Bit	Bit Name	Initial Value	R/W	Description
1	CLK1_ON	1b	RW	The WDT0_CLK clock is supplied or stopped. 0: Clock is stopped. 1: Clock is supplied.
0	CLK0_ON	1b	RW	The WDT0_PCLK clock is supplied or stopped. 0: Clock is stopped. 1: Clock is supplied.

7.2.4.27 Clock Control Register DDR (CPG_CLKON_DDR)

This register is used to supply or stop clocks for individual modules.

Bit	31	30	29	28	27	26	25	24	23	22	21	20	19	18	17	16
	—	—	—	—	—	—	—	—	—	—	—	—	—	—	CLK1_ON NWEN	CLK0_ON NWEN
Initial Value	0	0	0	0	0	0	0	0	0	0	0	0	0	0	0	0
R/W	R	R	R	R	R	R	R	R	R	R	R	R	R	R	R0W1	R0W1
Bit	15	14	13	12	11	10	9	8	7	6	5	4	3	2	1	0
	—	—	—	—	—	—	—	—	—	—	—	—	—	—	CLK1_ON N	CLK0_ON N
Initial Value	0	0	0	0	0	0	0	0	0	0	0	0	0	0	0	0
R/W	R	R	R	R	R	R	R	R	R	R	R	R	R	R	RW	RW

Bit	Bit Name	Initial Value	R/W	Description
31 to 18	—	All 0	R	Reserved Whenever it is read, 0 is read. The written value will be ignored.
17	CLK1_ONWE N	0b	R0W1	Flag for enabling the writing to the CLK1_ON bit (bit 1) This bit is always read as 0. 0: Writing is disabled. 1: Writing is enabled.
16	CLK0_ONWE N	0b	R0W1	Flag for enabling the writing to the CLK0_ON bit (bit 0) This bit is always read as 0. 0: Writing is disabled. 1: Writing is enabled.
15 to 2	—	All 0	R	Reserved Whenever it is read, 0 is read. The written value will be ignored.
1	CLK1_ON	0b	RW	The DDR_REG_ACLK clock is supplied or stopped. 0: Clock is stopped. 1: Clock is supplied.
0	CLK0_ON	0b	RW	The DDR_PCLK clock is supplied or stopped. 0: Clock is stopped. 1: Clock is supplied.

7.2.4.28 Clock Control Register SPI_MULTI (CPG_CLKON_SPI_MULTI)

This register is used to supply or stop clocks for individual modules.

Bit	31	30	29	28	27	26	25	24	23	22	21	20	19	18	17	16
	—	—	—	—	—	—	—	—	—	—	—	—	—	—	CLK1_ON NWEN	CLK0_ON NWEN
Initial Value	0	0	0	0	0	0	0	0	0	0	0	0	0	0	0	0
R/W	R	R	R	R	R	R	R	R	R	R	R	R	R	R	R0W1	R0W1
Bit	15	14	13	12	11	10	9	8	7	6	5	4	3	2	1	0
	—	—	—	—	—	—	—	—	—	—	—	—	—	—	CLK1_ON N	CLK0_ON N
Initial Value	0	0	0	0	0	0	0	0	0	0	0	0	0	0	0	0
R/W	R	R	R	R	R	R	R	R	R	R	R	R	R	R	RW	RW

Bit	Bit Name	Initial Value	R/W	Description
31 to 18	—	All 0	R	Reserved Whenever it is read, 0 is read. The written value will be ignored.
17	CLK1_ONWE N	0b	R0W1	Flag for enabling the writing to the CLK1_ON bit (bit 1) This bit is always read as 0. 0: Writing is disabled. 1: Writing is enabled.
16	CLK0_ONWE N	0b	R0W1	Flag for enabling the writing to the CLK0_ON bit (bit 0) This bit is always read as 0. 0: Writing is disabled. 1: Writing is enabled.
15 to 2	—	All 0	R	Reserved Whenever it is read, 0 is read. The written value will be ignored.
1	CLK1_ON	0b	RW	The SPI_CLK clock is supplied or stopped. 0: Clock is stopped. 1: Clock is supplied.
0	CLK0_ON	0b	RW	The SPI_CLK2 clock is supplied or stopped. 0: Clock is stopped. 1: Clock is supplied.

7.2.4.29 Clock Control Register SDHI (CPG_CLKON_SDHI)

This register is used to supply or stop clocks for individual modules.

Bit	31	30	29	28	27	26	25	24	23	22	21	20	19	18	17	16
	—	—	—	—	—	—	—	—	CLK7_ONWE	CLK6_ONWE	CLK5_ONWE	CLK4_ONWE	CLK3_ONWE	CLK2_ONWE	CLK1_ONWE	CLK0_ONWE
Initial Value	0	0	0	0	0	0	0	0	0	0	0	0	0	0	0	0
R/W	R	R	R	R	R	R	R	R	R0W1	R0W1	R0W1	R0W1	R0W1	R0W1	R0W1	R0W1
Bit	15	14	13	12	11	10	9	8	7	6	5	4	3	2	1	0
	—	—	—	—	—	—	—	—	CLK7_ONWE	CLK6_ONWE	CLK5_ONWE	CLK4_ONWE	CLK3_ONWE	CLK2_ONWE	CLK1_ONWE	CLK0_ONWE
Initial Value	0	0	0	0	0	0	0	0	0	0	0	0	0	0	0	0
R/W	R	R	R	R	R	R	R	R	RW	RW	RW	RW	RW	RW	RW	RW

Bit	Bit Name	Initial Value	R/W	Description
31 to 24	—	All 0	R	Reserved Whenever it is read, 0 is read. The written value will be ignored.
23	CLK7_ONWE N	0b	R0W1	Flag for enabling the writing to the CLK7_ON bit (bit 7) This bit is always read as 0. 0: Writing is disabled. 1: Writing is enabled.
22	CLK6_ONWE N	0b	R0W1	Flag for enabling the writing to the CLK6_ON bit (bit 6) This bit is always read as 0. 0: Writing is disabled. 1: Writing is enabled.
21	CLK5_ONWE N	0b	R0W1	Flag for enabling the writing to the CLK5_ON bit (bit 5) This bit is always read as 0. 0: Writing is disabled. 1: Writing is enabled.
20	CLK4_ONWE N	0b	R0W1	Flag for enabling the writing to the CLK4_ON bit (bit 4) This bit is always read as 0. 0: Writing is disabled. 1: Writing is enabled.
19	CLK3_ONWE N	0b	R0W1	Flag for enabling the writing to the CLK3_ON bit (bit 3) This bit is always read as 0. 0: Writing is disabled. 1: Writing is enabled.
18	CLK2_ONWE N	0b	R0W1	Flag for enabling the writing to the CLK2_ON bit (bit 2) This bit is always read as 0. 0: Writing is disabled. 1: Writing is enabled.
17	CLK1_ONWE N	0b	R0W1	Flag for enabling the writing to the CLK1_ON bit (bit 1) This bit is always read as 0. 0: Writing is disabled. 1: Writing is enabled.
16	CLK0_ONWE N	0b	R0W1	Flag for enabling the writing to the CLK0_ON bit (bit 0) This bit is always read as 0. 0: Writing is disabled. 1: Writing is enabled.
15 to 8	—	All 0	R	Reserved Whenever it is read, 0 is read. The written value will be ignored.

Bit	Bit Name	Initial Value	R/W	Description
7	CLK7_ON	0b	RW	The SDHI1_ACLK clock is supplied or stopped. 0: Clock is stopped. 1: Clock is supplied.
6	CLK6_ON	0b	RW	The SDHI1_CLK_HS clock is supplied or stopped. 0: Clock is stopped. 1: Clock is supplied.
5	CLK5_ON	0b	RW	The SDHI1_IMCLK2 clock is supplied or stopped. 0: Clock is stopped. 1: Clock is supplied.
4	CLK4_ON	0b	RW	The SDHI1_IMCLK clock is supplied or stopped. 0: Clock is stopped. 1: Clock is supplied.
3	CLK3_ON	0b	RW	The SDHI0_ACLK clock is supplied or stopped. 0: Clock is stopped. 1: Clock is supplied.
2	CLK2_ON	0b	RW	The SDHI0_CLK_HS clock is supplied or stopped. 0: Clock is stopped. 1: Clock is supplied.
1	CLK1_ON	0b	RW	The SDHI0_IMCLK2 clock is supplied or stopped. 0: Clock is stopped. 1: Clock is supplied.
0	CLK0_ON	0b	RW	The SDHI0_IMCLK clock is supplied or stopped. 0: Clock is stopped. 1: Clock is supplied.

7.2.4.30 Clock Control Register SSI (CPG_CLKON_SSI)

This register is used to supply or stop clocks for individual modules.

Bit	31	30	29	28	27	26	25	24	23	22	21	20	19	18	17	16
	—	—	—	—	—	—	—	—	CLK7_ONWE	CLK6_ONWE	CLK5_ONWE	CLK4_ONWE	CLK3_ONWE	CLK2_ONWE	CLK1_ONWE	CLK0_ONWE
Initial Value	0	0	0	0	0	0	0	0	0	0	0	0	0	0	0	0
R/W	R	R	R	R	R	R	R	R	R0W1	R0W1	R0W1	R0W1	R0W1	R0W1	R0W1	R0W1
Bit	15	14	13	12	11	10	9	8	7	6	5	4	3	2	1	0
	—	—	—	—	—	—	—	—	CLK7_ONWE	CLK6_ONWE	CLK5_ONWE	CLK4_ONWE	CLK3_ONWE	CLK2_ONWE	CLK1_ONWE	CLK0_ONWE
Initial Value	0	0	0	0	0	0	0	0	0	0	0	0	0	0	0	0
R/W	R	R	R	R	R	R	R	R	RW	RW	RW	RW	RW	RW	RW	RW

Bit	Bit Name	Initial Value	R/W	Description
31 to 24	—	All 0	R	Reserved Whenever it is read, 0 is read. The written value will be ignored.
23	CLK7_ONWE N	0b	R0W1	Flag for enabling the writing to the CLK7_ON bit (bit 7) This bit is always read as 0. 0: Writing is disabled. 1: Writing is enabled.
22	CLK6_ONWE N	0b	R0W1	Flag for enabling the writing to the CLK6_ON bit (bit 6) This bit is always read as 0. 0: Writing is disabled. 1: Writing is enabled.
21	CLK5_ONWE N	0b	R0W1	Flag for enabling the writing to the CLK5_ON bit (bit 5) This bit is always read as 0. 0: Writing is disabled. 1: Writing is enabled.
20	CLK4_ONWE N	0b	R0W1	Flag for enabling the writing to the CLK4_ON bit (bit 4) This bit is always read as 0. 0: Writing is disabled. 1: Writing is enabled.
19	CLK3_ONWE N	0b	R0W1	Flag for enabling the writing to the CLK3_ON bit (bit 3) This bit is always read as 0. 0: Writing is disabled. 1: Writing is enabled.
18	CLK2_ONWE N	0b	R0W1	Flag for enabling the writing to the CLK2_ON bit (bit 2) This bit is always read as 0. 0: Writing is disabled. 1: Writing is enabled.
17	CLK1_ONWE N	0b	R0W1	Flag for enabling the writing to the CLK1_ON bit (bit 1) This bit is always read as 0. 0: Writing is disabled. 1: Writing is enabled.
16	CLK0_ONWE N	0b	R0W1	Flag for enabling the writing to the CLK0_ON bit (bit 0) This bit is always read as 0. 0: Writing is disabled. 1: Writing is enabled.
15 to 8	—	All 0	R	Reserved Whenever it is read, 0 is read. The written value will be ignored.

Bit	Bit Name	Initial Value	R/W	Description
7	CLK7_ON	0b	RW	The SSI3_PCLK_SFR clock is supplied or stopped. 0: Clock is stopped. 1: Clock is supplied.
6	CLK6_ON	0b	RW	The SSI3_PCLK2 clock is supplied or stopped. 0: Clock is stopped. 1: Clock is supplied.
5	CLK5_ON	0b	RW	The SSI2_PCLK_SFR clock is supplied or stopped. 0: Clock is stopped. 1: Clock is supplied.
4	CLK4_ON	0b	RW	The SSI2_PCLK2 clock is supplied or stopped. 0: Clock is stopped. 1: Clock is supplied.
3	CLK3_ON	0b	RW	The SSI1_PCLK_SFR clock is supplied or stopped. 0: Clock is stopped. 1: Clock is supplied.
2	CLK2_ON	0b	RW	The SSI1_PCLK2 clock is supplied or stopped. 0: Clock is stopped. 1: Clock is supplied.
1	CLK1_ON	0b	RW	The SSI0_PCLK_SFR clock is supplied or stopped. 0: Clock is stopped. 1: Clock is supplied.
0	CLK0_ON	0b	RW	The SSI0_PCLK2 clock is supplied or stopped. 0: Clock is stopped. 1: Clock is supplied.

7.2.4.31 Clock Control Register USB (CPG_CLKON_USB)

This register is used to supply or stop clocks for individual modules.

Bit	31	30	29	28	27	26	25	24	23	22	21	20	19	18	17	16
	—	—	—	—	—	—	—	—	—	—	—	—	CLK3_ONWEN	CLK2_ONWEN	CLK1_ONWEN	CLK0_ONWEN
Initial Value	0	0	0	0	0	0	0	0	0	0	0	0	0	0	0	0
R/W	R	R	R	R	R	R	R	R	R	R	R	R	R0W1	R0W1	R0W1	R0W1
Bit	15	14	13	12	11	10	9	8	7	6	5	4	3	2	1	0
	—	—	—	—	—	—	—	—	—	—	—	—	CLK3_ONN	CLK2_ONN	CLK1_ONN	CLK0_ONN
Initial Value	0	0	0	0	0	0	0	0	0	0	0	0	0	0	0	0
R/W	R	R	R	R	R	R	R	R	R	R	R	R	RW	RW	RW	RW

Bit	Bit Name	Initial Value	R/W	Description
31 to 20	—	All 0	R	Reserved Whenever it is read, 0 is read. The written value will be ignored.
19	CLK3_ONWEN	0b	R0W1	Flag for enabling the writing to the CLK3_ON bit (bit 3) This bit is always read as 0. 0: Writing is disabled. 1: Writing is enabled.
18	CLK2_ONWEN	0b	R0W1	Flag for enabling the writing to the CLK2_ON bit (bit 2) This bit is always read as 0. 0: Writing is disabled. 1: Writing is enabled.
17	CLK1_ONWEN	0b	R0W1	Flag for enabling the writing to the CLK1_ON bit (bit 1) This bit is always read as 0. 0: Writing is disabled. 1: Writing is enabled.
16	CLK0_ONWEN	0b	R0W1	Flag for enabling the writing to the CLK0_ON bit (bit 0) This bit is always read as 0. 0: Writing is disabled. 1: Writing is enabled.
15 to 4	—	All 0	R	Reserved Whenever it is read, 0 is read. The written value will be ignored.
3	CLK3_ON	0b	RW	The USB_PCLK clock is supplied or stopped. 0: Clock is stopped. 1: Clock is supplied.
2	CLK2_ON	0b	RW	The USB_U2P_EXR_CPUCLK clock is supplied or stopped. 0: Clock is stopped. 1: Clock is supplied.
1	CLK1_ON	0b	RW	The USB_U2H1_HCLK clock is supplied or stopped. 0: Clock is stopped. 1: Clock is supplied.
0	CLK0_ON	0b	RW	The USB_U2H0_HCLK clock is supplied or stopped. 0: Clock is stopped. 1: Clock is supplied.

7.2.4.32 Clock Control Register ETH (CPG_CLKON_ETH)

This register is used to supply or stop clocks for individual modules.

Bit	31	30	29	28	27	26	25	24	23	22	21	20	19	18	17	16
	—	—	—	—	—	—	—	—	—	—	—	—	—	—	CLK1_ON NWEN	CLK0_ON NWEN
Initial Value	0	0	0	0	0	0	0	0	0	0	0	0	0	0	0	0
R/W	R	R	R	R	R	R	R	R	R	R	R	R	R	R	R0W1	R0W1
Bit	15	14	13	12	11	10	9	8	7	6	5	4	3	2	1	0
	—	—	—	—	—	—	—	—	—	—	—	—	—	—	CLK1_ON N	CLK0_ON N
Initial Value	0	0	0	0	0	0	0	0	0	0	0	0	0	0	0	0
R/W	R	R	R	R	R	R	R	R	R	R	R	R	R	R	RW	RW

Bit	Bit Name	Initial Value	R/W	Description
31 to 18	—	All 0	R	Reserved Whenever it is read, 0 is read. The written value will be ignored.
17	CLK1_ONWE N	0b	R0W1	Flag for enabling the writing to the CLK1_ON bit (bit 1) This bit is always read as 0. 0: Writing is disabled. 1: Writing is enabled.
16	CLK0_ONWE N	0b	R0W1	Flag for enabling the writing to the CLK0_ON bit (bit 0) This bit is always read as 0. 0: Writing is disabled. 1: Writing is enabled.
15 to 2	—	All 0	R	Reserved Whenever it is read, 0 is read. The written value will be ignored.
1	CLK1_ON	0b	RW	The ETH1_CLK_AXI/CHI clock is supplied or stopped. 0: Clock is stopped. 1: Clock is supplied.
0	CLK0_ON	0b	RW	The ETH0_CLK_AXI/CHI clock is supplied or stopped. 0: Clock is stopped. 1: Clock is supplied.

7.2.4.33 Clock Control Register I2C (CPG_CLKON_I2C)

This register is used to supply or stop clocks for individual modules.

Bit	31	30	29	28	27	26	25	24	23	22	21	20	19	18	17	16
	—	—	—	—	—	—	—	—	—	—	—	—	CLK3_ON NWEN	CLK2_ON NWEN	CLK1_ON NWEN	CLK0_ON NWEN
Initial Value	0	0	0	0	0	0	0	0	0	0	0	0	0	0	0	0
R/W	R	R	R	R	R	R	R	R	R	R	R	R	R0W1	R0W1	R0W1	R0W1
Bit	15	14	13	12	11	10	9	8	7	6	5	4	3	2	1	0
	—	—	—	—	—	—	—	—	—	—	—	—	CLK3_ON N	CLK2_ON N	CLK1_ON N	CLK0_ON N
Initial Value	0	0	0	0	0	0	0	0	0	0	0	0	0	0	0	0
R/W	R	R	R	R	R	R	R	R	R	R	R	R	RW	RW	RW	RW

Bit	Bit Name	Initial Value	R/W	Description
31 to 20	—	All 0	R	Reserved Whenever it is read, 0 is read. The written value will be ignored.
19	CLK3_ONWE N	0b	R0W1	Flag for enabling the writing to the CLK3_ON bit (bit 3) This bit is always read as 0. 0: Writing is disabled. 1: Writing is enabled.
18	CLK2_ONWE N	0b	R0W1	Flag for enabling the writing to the CLK2_ON bit (bit 2) This bit is always read as 0. 0: Writing is disabled. 1: Writing is enabled.
17	CLK1_ONWE N	0b	R0W1	Flag for enabling the writing to the CLK1_ON bit (bit 1) This bit is always read as 0. 0: Writing is disabled. 1: Writing is enabled.
16	CLK0_ONWE N	0b	R0W1	Flag for enabling the writing to the CLK0_ON bit (bit 0) This bit is always read as 0. 0: Writing is disabled. 1: Writing is enabled.
15 to 4	—	All 0	R	Reserved Whenever it is read, 0 is read. The written value will be ignored.
3	CLK3_ON	0b	RW	The I2C3_PCLK clock is supplied or stopped. 0: Clock is stopped. 1: Clock is supplied.
2	CLK2_ON	0b	RW	The I2C2_PCLK clock is supplied or stopped. 0: Clock is stopped. 1: Clock is supplied.
1	CLK1_ON	0b	RW	The I2C1_PCLK clock is supplied or stopped. 0: Clock is stopped. 1: Clock is supplied.
0	CLK0_ON	0b	RW	The I2C0_PCLK clock is supplied or stopped. 0: Clock is stopped. 1: Clock is supplied.

7.2.4.34 Clock Control Register SCIF (CPG_CLKON_SCIF)

This register is used to supply or stop clocks for individual modules.

Bit	31	30	29	28	27	26	25	24	23	22	21	20	19	18	17	16
	—	—	—	—	—	—	—	—	—	—	—	CLK4_ONWE	CLK3_ONWE	CLK2_ONWE	CLK1_ONWE	CLK0_ONWE
Initial Value	0	0	0	0	0	0	0	0	0	0	0	0	0	0	0	0
R/W	R	R	R	R	R	R	R	R	R	R	R	R0W1	R0W1	R0W1	R0W1	R0W1
Bit	15	14	13	12	11	10	9	8	7	6	5	4	3	2	1	0
	—	—	—	—	—	—	—	—	—	—	—	CLK4_ON	CLK3_ON	CLK2_ON	CLK1_ON	CLK0_ON
Initial Value	0	0	0	0	0	0	0	0	0	0	0	0	0	0	0	0
R/W	R	R	R	R	R	R	R	R	R	R	R	RW	RW	RW	RW	RW

Bit	Bit Name	Initial Value	R/W	Description
31 to 21	—	All 0	R	Reserved Whenever it is read, 0 is read. The written value will be ignored.
20	CLK4_ONWE N	0b	R0W1	Flag for enabling the writing to the CLK4_ON bit (bit 4) This bit is always read as 0. 0: Writing is disabled. 1: Writing is enabled.
19	CLK3_ONWE N	0b	R0W1	Flag for enabling the writing to the CLK3_ON bit (bit 3) This bit is always read as 0. 0: Writing is disabled. 1: Writing is enabled.
18	CLK2_ONWE N	0b	R0W1	Flag for enabling the writing to the CLK2_ON bit (bit 2) This bit is always read as 0. 0: Writing is disabled. 1: Writing is enabled.
17	CLK1_ONWE N	0b	R0W1	Flag for enabling the writing to the CLK1_ON bit (bit 1) This bit is always read as 0. 0: Writing is disabled. 1: Writing is enabled.
16	CLK0_ONWE N	0b	R0W1	Flag for enabling the writing to the CLK0_ON bit (bit 0) This bit is always read as 0. 0: Writing is disabled. 1: Writing is enabled.
15 to 5	—	All 0	R	Reserved Whenever it is read, 0 is read. The written value will be ignored.
4	CLK4_ON	0b	RW	The SCIF4_CLK_PCK clock is supplied or stopped. 0: Clock is stopped. 1: Clock is supplied.
3	CLK3_ON	0b	RW	The SCIF3_CLK_PCK clock is supplied or stopped. 0: Clock is stopped. 1: Clock is supplied.
2	CLK2_ON	0b	RW	The SCIF2_CLK_PCK clock is supplied or stopped. 0: Clock is stopped. 1: Clock is supplied.
1	CLK1_ON	0b	RW	The SCIF1_CLK_PCK clock is supplied or stopped. 0: Clock is stopped. 1: Clock is supplied.

Bit	Bit Name	Initial Value	R/W	Description
0	CLK0_ON	0b	RW	The SCIF0_CLK_PCK clock is supplied or stopped. 0: Clock is stopped. 1: Clock is supplied.

7.2.4.35 Clock Control Register SCI (CPG_CLKON_SCI)

This register is used to supply or stop clocks for individual modules.

Bit	31	30	29	28	27	26	25	24	23	22	21	20	19	18	17	16
	—	—	—	—	—	—	—	—	—	—	—	—	—	—	CLK1_ON NWEN	CLK0_ON NWEN
Initial Value	0	0	0	0	0	0	0	0	0	0	0	0	0	0	0	0
R/W	R	R	R	R	R	R	R	R	R	R	R	R	R	R	R0W1	R0W1
Bit	15	14	13	12	11	10	9	8	7	6	5	4	3	2	1	0
	—	—	—	—	—	—	—	—	—	—	—	—	—	—	CLK1_ON N	CLK0_ON N
Initial Value	0	0	0	0	0	0	0	0	0	0	0	0	0	0	0	0
R/W	R	R	R	R	R	R	R	R	R	R	R	R	R	R	RW	RW

Bit	Bit Name	Initial Value	R/W	Description
31 to 18	—	All 0	R	Reserved Whenever it is read, 0 is read. The written value will be ignored.
17	CLK1_ONWE N	0b	R0W1	Flag for enabling the writing to the CLK1_ON bit (bit 1) This bit is always read as 0. 0: Writing is disabled. 1: Writing is enabled.
16	CLK0_ONWE N	0b	R0W1	Flag for enabling the writing to the CLK0_ON bit (bit 0) This bit is always read as 0. 0: Writing is disabled. 1: Writing is enabled.
15 to 2	—	All 0	R	Reserved Whenever it is read, 0 is read. The written value will be ignored.
1	CLK1_ON	0b	RW	The SCI1_CLKP clock is supplied or stopped. 0: Clock is stopped. 1: Clock is supplied.
0	CLK0_ON	0b	RW	The SCI0_CLKP clock is supplied or stopped. 0: Clock is stopped. 1: Clock is supplied.

7.2.4.36 Clock Control Register IRDA (CPG_CLKON_IRDA)

This register is used to supply or stop clocks for individual modules.

Bit	31	30	29	28	27	26	25	24	23	22	21	20	19	18	17	16
	—	—	—	—	—	—	—	—	—	—	—	—	—	—	—	CLK0_ONWEN
Initial Value	0	0	0	0	0	0	0	0	0	0	0	0	0	0	0	0
R/W	R	R	R	R	R	R	R	R	R	R	R	R	R	R	R	R0W1
Bit	15	14	13	12	11	10	9	8	7	6	5	4	3	2	1	0
	—	—	—	—	—	—	—	—	—	—	—	—	—	—	—	CLK0_ON
Initial Value	0	0	0	0	0	0	0	0	0	0	0	0	0	0	0	0
R/W	R	R	R	R	R	R	R	R	R	R	R	R	R	R	R	RW

Bit	Bit Name	Initial Value	R/W	Description
31 to 17	—	All 0	R	Reserved Whenever it is read, 0 is read. The written value will be ignored.
16	CLK0_ONWEN	0b	R0W1	Flag for enabling the writing to the CLK0_ON bit (bit 0) This bit is always read as 0. 0: Writing is disabled. 1: Writing is enabled.
15 to 1	—	All 0	R	Reserved Whenever it is read, 0 is read. The written value will be ignored.
0	CLK0_ON	0b	RW	The IRDA_CLKP clock is supplied or stopped. 0: Clock is stopped. 1: Clock is supplied.

7.2.4.37 Clock Control Register RSPI (CPG_CLKON_RSPI)

This register is used to supply or stop clocks for individual modules.

Bit	31	30	29	28	27	26	25	24	23	22	21	20	19	18	17	16
	—	—	—	—	—	—	—	—	—	—	—	—	—	CLK2_ON NWEN	CLK1_ON NWEN	CLK0_ON NWEN
Initial Value	0	0	0	0	0	0	0	0	0	0	0	0	0	0	0	0
R/W	R	R	R	R	R	R	R	R	R	R	R	R	R	R0W1	R0W1	R0W1
Bit	15	14	13	12	11	10	9	8	7	6	5	4	3	2	1	0
	—	—	—	—	—	—	—	—	—	—	—	—	—	CLK2_ON N	CLK1_ON N	CLK0_ON N
Initial Value	0	0	0	0	0	0	0	0	0	0	0	0	0	0	0	0
R/W	R	R	R	R	R	R	R	R	R	R	R	R	R	RW	RW	RW

Bit	Bit Name	Initial Value	R/W	Description
31 to 19	—	All 0	R	Reserved Whenever it is read, 0 is read. The written value will be ignored.
18	CLK2_ONWE N	0b	R0W1	Flag for enabling the writing to the CLK2_ON bit (bit 2) This bit is always read as 0. 0: Writing is disabled. 1: Writing is enabled.
17	CLK1_ONWE N	0b	R0W1	Flag for enabling the writing to the CLK1_ON bit (bit 1) This bit is always read as 0. 0: Writing is disabled. 1: Writing is enabled.
16	CLK0_ONWE N	0b	R0W1	Flag for enabling the writing to the CLK0_ON bit (bit 0) This bit is always read as 0. 0: Writing is disabled. 1: Writing is enabled.
15 to 3	—	All 0	R	Reserved Whenever it is read, 0 is read. The written value will be ignored.
2	CLK2_ON	0b	RW	The RSPi2_CLKB clock is supplied or stopped. 0: Clock is stopped. 1: Clock is supplied.
1	CLK1_ON	0b	RW	The RSPi1_CLKB clock is supplied or stopped. 0: Clock is stopped. 1: Clock is supplied.
0	CLK0_ON	0b	RW	The RSPi0_CLKB clock is supplied or stopped. 0: Clock is stopped. 1: Clock is supplied.

7.2.4.38 Clock Control Register CANFD (CPG_CLKON_CANFD)

This register is used to supply or stop clocks for individual modules.

Bit	31	30	29	28	27	26	25	24	23	22	21	20	19	18	17	16
	—	—	—	—	—	—	—	—	—	—	—	—	—	—	—	CLK0_ONWEN
Initial Value	0	0	0	0	0	0	0	0	0	0	0	0	0	0	0	0
R/W	R	R	R	R	R	R	R	R	R	R	R	R	R	R	R	R0W1
Bit	15	14	13	12	11	10	9	8	7	6	5	4	3	2	1	0
	—	—	—	—	—	—	—	—	—	—	—	—	—	—	—	CLK0_ON
Initial Value	0	0	0	0	0	0	0	0	0	0	0	0	0	0	0	0
R/W	R	R	R	R	R	R	R	R	R	R	R	R	R	R	R	RW

Bit	Bit Name	Initial Value	R/W	Description
31 to 17	—	All 0	R	Reserved Whenever it is read, 0 is read. The written value will be ignored.
16	CLK0_ONWEN	0b	R0W1	Flag for enabling the writing to the CLK0_ON bit (bit 0) This bit is always read as 0. 0: Writing is disabled. 1: Writing is enabled.
15 to 1	—	All 0	R	Reserved Whenever it is read, 0 is read. The written value will be ignored.
0	CLK0_ON	0b	RW	The CANFD_PCLK clock is supplied or stopped. 0: Clock is stopped. 1: Clock is supplied.

7.2.4.39 Clock Control Register GPIO (CPG_CLKON_GPIO)

This register is used to supply or stop clocks for individual modules.

Bit	31	30	29	28	27	26	25	24	23	22	21	20	19	18	17	16
	—	—	—	—	—	—	—	—	—	—	—	—	—	—	—	CLK0_ONWEN
Initial Value	0	0	0	0	0	0	0	0	0	0	0	0	0	0	0	0
R/W	R	R	R	R	R	R	R	R	R	R	R	R	R	R	R	R0W1
Bit	15	14	13	12	11	10	9	8	7	6	5	4	3	2	1	0
	—	—	—	—	—	—	—	—	—	—	—	—	—	—	—	CLK0_ON
Initial Value	0	0	0	0	0	0	0	0	0	0	0	0	0	0	0	0
R/W	R	R	R	R	R	R	R	R	R	R	R	R	R	R	R	RW

Bit	Bit Name	Initial Value	R/W	Description
31 to 17	—	All 0	R	Reserved Whenever it is read, 0 is read. The written value will be ignored.
16	CLK0_ONWEN	0b	R0W1	Flag for enabling the writing to the CLK0_ON bit (bit 0) This bit is always read as 0. 0: Writing is disabled. 1: Writing is enabled.
15 to 1	—	All 0	R	Reserved Whenever it is read, 0 is read. The written value will be ignored.
0	CLK0_ON	0b	RW	The GPIO_HCLK clock is supplied or stopped. 0: Clock is stopped. 1: Clock is supplied.

7.2.4.40 Clock Control Register ADC (CPG_CLKON_ADC)

This register is used to supply or stop clocks for individual modules.

Bit	31	30	29	28	27	26	25	24	23	22	21	20	19	18	17	16
	—	—	—	—	—	—	—	—	—	—	—	—	—	—	CLK1_ON NWEN	CLK0_ON NWEN
Initial Value	0	0	0	0	0	0	0	0	0	0	0	0	0	0	0	0
R/W	R	R	R	R	R	R	R	R	R	R	R	R	R	R	R0W1	R0W1
Bit	15	14	13	12	11	10	9	8	7	6	5	4	3	2	1	0
	—	—	—	—	—	—	—	—	—	—	—	—	—	—	CLK1_ON N	CLK0_ON N
Initial Value	0	0	0	0	0	0	0	0	0	0	0	0	0	0	0	0
R/W	R	R	R	R	R	R	R	R	R	R	R	R	R	R	RW	RW

Bit	Bit Name	Initial Value	R/W	Description
31 to 18	—	All 0	R	Reserved Whenever it is read, 0 is read. The written value will be ignored.
17	CLK1_ONWE N	0b	R0W1	Flag for enabling the writing to the CLK1_ON bit (bit 1) This bit is always read as 0. 0: Writing is disabled. 1: Writing is enabled.
16	CLK0_ONWE N	0b	R0W1	Flag for enabling the writing to the CLK0_ON bit (bit 0) This bit is always read as 0. 0: Writing is disabled. 1: Writing is enabled.
15 to 2	—	All 0	R	Reserved Whenever it is read, 0 is read. The written value will be ignored.
1	CLK1_ON	0b	RW	The ADC_PCLK clock is supplied or stopped. 0: Clock is stopped. 1: Clock is supplied.
0	CLK0_ON	0b	RW	The ADC_ADCLK clock is supplied or stopped. 0: Clock is stopped. 1: Clock is supplied.

7.2.4.41 Clock Control Register TSU (CPG_CLKON_TSU)

This register is used to supply or stop clocks for individual modules.

Bit	31	30	29	28	27	26	25	24	23	22	21	20	19	18	17	16
	—	—	—	—	—	—	—	—	—	—	—	—	—	—	—	CLK0_ONWEN
Initial Value	0	0	0	0	0	0	0	0	0	0	0	0	0	0	0	0
R/W	R	R	R	R	R	R	R	R	R	R	R	R	R	R	R	R0W1
Bit	15	14	13	12	11	10	9	8	7	6	5	4	3	2	1	0
	—	—	—	—	—	—	—	—	—	—	—	—	—	—	—	CLK0_ON
Initial Value	0	0	0	0	0	0	0	0	0	0	0	0	0	0	0	0
R/W	R	R	R	R	R	R	R	R	R	R	R	R	R	R	R	RW

Bit	Bit Name	Initial Value	R/W	Description
31 to 17	—	All 0	R	Reserved Whenever it is read, 0 is read. The written value will be ignored.
16	CLK0_ONWEN	0b	R0W1	Flag for enabling the writing to the CLK0_ON bit (bit 0) This bit is always read as 0. 0: Writing is disabled. 1: Writing is enabled.
15 to 1	—	All 0	R	Reserved Whenever it is read, 0 is read. The written value will be ignored.
0	CLK0_ON	0b	RW	The TSU_PCLK clock is supplied or stopped. 0: Clock is stopped. 1: Clock is supplied.

7.2.4.42 Clock Control Register AXI_TZCDDR (CPG_CLKON_AXI_TZCDDR)

This register is used to supply or stop clocks for individual modules.

Bit	31	30	29	28	27	26	25	24	23	22	21	20	19	18	17	16
	—	—	—	—	—	—	—	—	—	—	—	—	—	CLK2_ON NWEN	CLK1_ON NWEN	CLK0_ON NWEN
Initial Value	0	0	0	0	0	0	0	0	0	0	0	0	0	0	0	0
R/W	R	R	R	R	R	R	R	R	R	R	R	R	R	R0W1	R0W1	R0W1
Bit	15	14	13	12	11	10	9	8	7	6	5	4	3	2	1	0
	—	—	—	—	—	—	—	—	—	—	—	—	—	CLK2_ON N	CLK1_ON N	CLK0_ON N
Initial Value	0	0	0	0	0	0	0	0	0	0	0	1	1	1	1	1
R/W	R	R	R	R	R	R	R	R	R	R	R	R	R	RW	RW	RW

Bit	Bit Name	Initial Value	R/W	Description
31 to 19	—	All 0	R	Reserved Whenever it is read, 0 is read. The written value will be ignored.
18	CLK2_ONWE N	0b	R0W1	Flag for enabling the writing to the CLK2_ON bit (bit 2) This bit is always read as 0. 0: Writing is disabled. 1: Writing is enabled.
17	CLK1_ONWE N	0b	R0W1	Flag for enabling the writing to the CLK1_ON bit (bit 1) This bit is always read as 0. 0: Writing is disabled. 1: Writing is enabled.
16	CLK0_ONWE N	0b	R0W1	Flag for enabling the writing to the CLK0_ON bit (bit 0) This bit is always read as 0. 0: Writing is disabled. 1: Writing is enabled.
15 to 5	—	All 0	R	Reserved Whenever it is read, 0 is read. The written value will be ignored.
4, 3	—	11b	R	Reserved When read, the initial value is read. When writing, be sure to write the initial value. Operation is not guaranteed if a value other than the initial value is written.
2	CLK2_ON	1b	RW	The BUS_TZCDDR_ACLK1 clock is supplied or stopped. 0: Clock is stopped. 1: Clock is supplied.
1	CLK1_ON	1b	RW	The BUS_TZCDDR_ACLK0 clock is supplied or stopped. 0: Clock is stopped. 1: Clock is supplied.
0	CLK0_ON	1b	RW	The BUS_TZCDDR_PCLK clock is supplied or stopped. 0: Clock is stopped. 1: Clock is supplied.

7.2.4.43 Clock Control Register AX45MP (CPG_CLKON_AX45MP)

This register is used to supply or stop clocks for individual modules.

Bit	31	30	29	28	27	26	25	24	23	22	21	20	19	18	17	16
	—	—	—	—	—	—	—	—	—	—	—	—	—	—	CLK1_ONWEN	CLK0_ONWEN
Initial Value	0	0	0	0	0	0	0	0	0	0	0	0	0	0	0	0
R/W	R	R	R	R	R	R	R	R	R	R	R	R	R	R	R0W1	R0W1
Bit	15	14	13	12	11	10	9	8	7	6	5	4	3	2	1	0
	—	—	—	—	—	—	—	—	—	—	—	—	—	—	CLK1_ON	CLK0_ON
Initial Value	0	0	0	0	0	0	0	0	0	0	0	0	0	0	1	1
R/W	R	R	R	R	R	R	R	R	R	R	R	R	R	R	RW	RW

Bit	Bit Name	Initial Value	R/W	Description
31 to 18	—	All 0	R	Reserved Whenever it is read, 0 is read. The written value will be ignored.
17	CLK1_ONWEN	0b	R0W1	Flag for enabling the writing to the CLK1_ON bit (bit 1) This bit is always read as 0. 0: Writing is disabled. 1: Writing is enabled.
16	CLK0_ONWEN	0b	R0W1	Flag for enabling the writing to the CLK0_ON bit (bit 0) This bit is always read as 0. 0: Writing is disabled. 1: Writing is enabled.
15 to 2	—	All 0	R	Reserved Whenever it is read, 0 is read. The written value will be ignored.
1	CLK1_ON	1b	RW	The AX45MP_ACLK clock is supplied or stopped. 0: Clock is stopped. 1: Clock is supplied.
0	CLK0_ON	1b	RW	The AX45MP_CORE0_CLK clock is supplied or stopped. 0: Clock is stopped. 1: Clock is supplied.

7.2.4.44 Clock Control Register NCEPLDM (CPG_CLKON_NCEPLDM)

This register is used to supply or stop clocks for individual modules.

Bit	31	30	29	28	27	26	25	24	23	22	21	20	19	18	17	16
	—	—	—	—	—	—	—	—	—	—	—	—	—	—	CLK1_ONWEN	—
Initial Value	0	0	0	0	0	0	0	0	0	0	0	0	0	0	0	0
R/W	R	R	R	R	R	R	R	R	R	R	R	R	R	R	R0W1	R
Bit	15	14	13	12	11	10	9	8	7	6	5	4	3	2	1	0
	—	—	—	—	—	—	—	—	—	—	—	—	—	—	CLK1_ON	—
Initial Value	0	0	0	0	0	0	0	0	0	0	0	0	0	0	1	1
R/W	R	R	R	R	R	R	R	R	R	R	R	R	R	R	RW	R

Bit	Bit Name	Initial Value	R/W	Description
31 to 18	—	All 0	R	Reserved Whenever it is read, 0 is read. The written value will be ignored.
17	CLK1_ONWEN	0b	R0W1	Flag for enabling the writing to the CLK1_ON bit (bit 1) This bit is always read as 0. 0: Writing is disabled. 1: Writing is enabled.
16	—	0b	R	Reserved Whenever it is read, 0 is read. The written value will be ignored.
15 to 2	—	All 0	R	Reserved Whenever it is read, 0 is read. The written value will be ignored.
1	CLK1_ON	1b	RW	The NCEPLDM_ACLK clock is supplied or stopped. 0: Clock is stopped. 1: Clock is supplied.
0	—	1b	R	Reserved When read, the initial value is read. When writing, be sure to write the initial value. Operation is not guaranteed if a value other than the initial value is written.

7.2.4.45 Clock Control Register NCEPLMT (CPG_CLKON_NCEPLMT)

This register is used to supply or stop clocks for individual modules.

Bit	31	30	29	28	27	26	25	24	23	22	21	20	19	18	17	16
	—	—	—	—	—	—	—	—	—	—	—	—	—	—	—	CLK0_ONWEN
Initial Value	0	0	0	0	0	0	0	0	0	0	0	0	0	0	0	0
R/W	R	R	R	R	R	R	R	R	R	R	R	R	R	R	R	R0W1
Bit	15	14	13	12	11	10	9	8	7	6	5	4	3	2	1	0
	—	—	—	—	—	—	—	—	—	—	—	—	—	—	—	CLK0_ON
Initial Value	0	0	0	0	0	0	0	0	0	0	0	0	0	0	0	1
R/W	R	R	R	R	R	R	R	R	R	R	R	R	R	R	R	RW

Bit	Bit Name	Initial Value	R/W	Description
31 to 17	—	All 0	R	Reserved Whenever it is read, 0 is read. The written value will be ignored.
16	CLK0_ONWEN	0b	R0W1	Flag for enabling the writing to the CLK0_ON bit (bit 0) This bit is always read as 0. 0: Writing is disabled. 1: Writing is enabled.
15 to 1	—	All 0	R	Reserved Whenever it is read, 0 is read. The written value will be ignored.
0	CLK0_ON	1b	RW	The NCEPLMT_ACLK clock is supplied or stopped. 0: Clock is stopped. 1: Clock is supplied.

7.2.4.46 Clock Control Register NCEPLIC (CPG_CLKON_NCEPLIC)

This register is used to supply or stop clocks for individual modules.

Bit	31	30	29	28	27	26	25	24	23	22	21	20	19	18	17	16
	—	—	—	—	—	—	—	—	—	—	—	—	—	—	—	CLK0_ONWEN
Initial Value	0	0	0	0	0	0	0	0	0	0	0	0	0	0	0	0
R/W	R	R	R	R	R	R	R	R	R	R	R	R	R	R	R	R0W1
Bit	15	14	13	12	11	10	9	8	7	6	5	4	3	2	1	0
	—	—	—	—	—	—	—	—	—	—	—	—	—	—	—	CLK0_ON
Initial Value	0	0	0	0	0	0	0	0	0	0	0	0	0	0	0	1
R/W	R	R	R	R	R	R	R	R	R	R	R	R	R	R	R	RW

Bit	Bit Name	Initial Value	R/W	Description
31 to 17	—	All 0	R	Reserved Whenever it is read, 0 is read. The written value will be ignored.
16	CLK0_ONWEN	0b	R0W1	Flag for enabling the writing to the CLK0_ON bit (bit 0) This bit is always read as 0. 0: Writing is disabled. 1: Writing is enabled.
15 to 1	—	All 0	R	Reserved Whenever it is read, 0 is read. The written value will be ignored.
0	CLK0_ON	1b	RW	The NCEPLIC_ACLK clock is supplied or stopped. 0: Clock is stopped. 1: Clock is supplied.

7.2.4.47 Clock Monitor Register SRAM_ACPU (CPG_CLKMON_SRAM_ACPU)

This register is used to monitor the state of the clocks supplied to individual modules.

Bit	31	30	29	28	27	26	25	24	23	22	21	20	19	18	17	16
	—	—	—	—	—	—	—	—	—	—	—	—	—	—	—	—
Initial Value	0	0	0	0	0	0	0	0	0	0	0	0	0	0	0	0
R/W	R	R	R	R	R	R	R	R	R	R	R	R	R	R	R	R
Bit	15	14	13	12	11	10	9	8	7	6	5	4	3	2	1	0
	—	—	—	—	—	—	—	—	—	—	—	—	—	—	—	CLK0_MON
Initial Value	0	0	0	0	0	0	0	0	0	0	0	0	0	0	0	1
R/W	R	R	R	R	R	R	R	R	R	R	R	R	R	R	R	R

Bit	Bit Name	Initial Value	R/W	Description
31 to 1	—	All 0	R	Reserved Whenever it is read, 0 is read. The written value will be ignored.
0	CLK0_MON	1b	R	The state of the SRAM_ACPU_ACLK clock is monitored. 0: Clock is not supplied. 1: Clock is supplied.

7.2.4.48 Clock Monitor Register SRAM_MCPU (CPG_CLKMON_SRAM_MCPU)

This register is used to monitor the state of the clocks supplied to individual modules.

Bit	31	30	29	28	27	26	25	24	23	22	21	20	19	18	17	16
	—	—	—	—	—	—	—	—	—	—	—	—	—	—	—	—
Initial Value	0	0	0	0	0	0	0	0	0	0	0	0	0	0	0	0
R/W	R	R	R	R	R	R	R	R	R	R	R	R	R	R	R	R
Bit	15	14	13	12	11	10	9	8	7	6	5	4	3	2	1	0
	—	—	—	—	—	—	—	—	—	—	—	—	—	—	—	CLK0_MON
Initial Value	0	0	0	0	0	0	0	0	0	0	0	0	0	0	0	1
R/W	R	R	R	R	R	R	R	R	R	R	R	R	R	R	R	R

Bit	Bit Name	Initial Value	R/W	Description
31 to 1	—	All 0	R	Reserved Whenever it is read, 0 is read. The written value will be ignored.
0	CLK0_MON	1b	R	The state of the SRAM_MCPU_ACLK clock is monitored. 0: Clock is not supplied. 1: Clock is supplied.

7.2.4.49 Clock Monitor Register IAX45 (CPG_CLKMON_IAX45)

This register is used to monitor the state of the clocks supplied to individual modules.

Bit	31	30	29	28	27	26	25	24	23	22	21	20	19	18	17	16
	—	—	—	—	—	—	—	—	—	—	—	—	—	—	—	—
Initial Value	0	0	0	0	0	0	0	0	0	0	0	0	0	0	0	0
R/W	R	R	R	R	R	R	R	R	R	R	R	R	R	R	R	R
Bit	15	14	13	12	11	10	9	8	7	6	5	4	3	2	1	0
	—	—	—	—	—	—	—	—	—	—	—	—	—	—	CLK1_MON	CLK0_MON
Initial Value	0	0	0	0	0	0	0	0	0	0	0	0	0	0	1	1
R/W	R	R	R	R	R	R	R	R	R	R	R	R	R	R	R	R

Bit	Bit Name	Initial Value	R/W	Description
31 to 2	—	All 0	R	Reserved Whenever it is read, 0 is read. The written value will be ignored.
1	CLK1_MON	1b	R	The state of the IAX45_CLK clock is monitored. 0: Clock is not supplied. 1: Clock is supplied.
0	CLK0_MON	1b	R	The state of the IAX45_PCLK clock is monitored. 0: Clock is not supplied. 1: Clock is supplied.

7.2.4.50 Clock Monitor Register SYC (CPG_CLKMON_SYC)

This register is used to monitor the state of the clocks supplied to individual modules.

Bit	31	30	29	28	27	26	25	24	23	22	21	20	19	18	17	16
	—	—	—	—	—	—	—	—	—	—	—	—	—	—	—	—
Initial Value	0	0	0	0	0	0	0	0	0	0	0	0	0	0	0	0
R/W	R	R	R	R	R	R	R	R	R	R	R	R	R	R	R	R
Bit	15	14	13	12	11	10	9	8	7	6	5	4	3	2	1	0
	—	—	—	—	—	—	—	—	—	—	—	—	—	—	—	CLK0_MON
Initial Value	0	0	0	0	0	0	0	0	0	0	0	0	0	0	0	0
R/W	R	R	R	R	R	R	R	R	R	R	R	R	R	R	R	R

Bit	Bit Name	Initial Value	R/W	Description
31 to 1	—	All 0	R	Reserved Whenever it is read, 0 is read. The written value will be ignored.
0	CLK0_MON	0b	R	The state of the SYC_CNT_CLK clock is monitored. 0: Clock is not supplied. 1: Clock is supplied.

7.2.4.51 Clock Monitor Register DMAC_REG (CPG_CLKMON_DMAM_REG)

This register is used to monitor the state of the clocks supplied to individual modules.

Bit	31	30	29	28	27	26	25	24	23	22	21	20	19	18	17	16
	—	—	—	—	—	—	—	—	—	—	—	—	—	—	—	—
Initial Value	0	0	0	0	0	0	0	0	0	0	0	0	0	0	0	0
R/W	R	R	R	R	R	R	R	R	R	R	R	R	R	R	R	R
Bit	15	14	13	12	11	10	9	8	7	6	5	4	3	2	1	0
	—	—	—	—	—	—	—	—	—	—	—	—	—	—	CLK1_MON	CLK0_MON
Initial Value	0	0	0	0	0	0	0	0	0	0	0	0	0	0	0	0
R/W	R	R	R	R	R	R	R	R	R	R	R	R	R	R	R	R

Bit	Bit Name	Initial Value	R/W	Description
31 to 2	—	All 0	R	Reserved Whenever it is read, 0 is read. The written value will be ignored.
1	CLK1_MON	0b	R	The state of the DMAC_PCLK clock is monitored. 0: Clock is not supplied. 1: Clock is supplied.
0	CLK0_MON	0b	R	The state of the DMAC_ACLK clock is monitored. 0: Clock is not supplied. 1: Clock is supplied.

7.2.4.52 Clock Monitor Register GTM (CPG_CLKMON_GTM)

This register is used to monitor the state of the clocks supplied to individual modules.

Bit	31	30	29	28	27	26	25	24	23	22	21	20	19	18	17	16
	—	—	—	—	—	—	—	—	—	—	—	—	—	—	—	—
Initial Value	0	0	0	0	0	0	0	0	0	0	0	0	0	0	0	0
R/W	R	R	R	R	R	R	R	R	R	R	R	R	R	R	R	R
Bit	15	14	13	12	11	10	9	8	7	6	5	4	3	2	1	0
	—	—	—	—	—	—	—	—	—	—	—	—	—	CLK2_MON	CLK1_MON	CLK0_MON
Initial Value	0	0	0	0	0	0	0	0	0	0	0	0	0	0	0	1
R/W	R	R	R	R	R	R	R	R	R	R	R	R	R	R	R	R

Bit	Bit Name	Initial Value	R/W	Description
31 to 3	—	All 0	R	Reserved Whenever it is read, 0 is read. The written value will be ignored.
2	CLK2_MON	0b	R	The state of the OSTM2_PCLK clock is monitored. 0: Clock is not supplied. 1: Clock is supplied.
1	CLK1_MON	0b	R	The state of the OSTM1_PCLK clock is monitored. 0: Clock is not supplied. 1: Clock is supplied.
0	CLK0_MON	1b	R	The state of the OSTM0_PCLK clock is monitored. 0: Clock is not supplied. 1: Clock is supplied.

7.2.4.53 Clock Monitor Register MTU (CPG_CLKMON_MTU)

This register is used to monitor the state of the clocks supplied to individual modules.

Bit	31	30	29	28	27	26	25	24	23	22	21	20	19	18	17	16
	—	—	—	—	—	—	—	—	—	—	—	—	—	—	—	—
Initial Value	0	0	0	0	0	0	0	0	0	0	0	0	0	0	0	0
R/W	R	R	R	R	R	R	R	R	R	R	R	R	R	R	R	R
Bit	15	14	13	12	11	10	9	8	7	6	5	4	3	2	1	0
	—	—	—	—	—	—	—	—	—	—	—	—	—	—	—	CLK0_MON
Initial Value	0	0	0	0	0	0	0	0	0	0	0	0	0	0	0	0
R/W	R	R	R	R	R	R	R	R	R	R	R	R	R	R	R	R

Bit	Bit Name	Initial Value	R/W	Description
31 to 1	—	All 0	R	Reserved Whenever it is read, 0 is read. The written value will be ignored.
0	CLK0_MON	0b	R	The state of the MTU_X_MCK_MTU3 clock is monitored. 0: Clock is not supplied. 1: Clock is supplied.

7.2.4.54 Clock Monitor Register POE3 (CPG_CLKMON_POE3)

This register is used to monitor the state of the clocks supplied to individual modules.

Bit	31	30	29	28	27	26	25	24	23	22	21	20	19	18	17	16
	—	—	—	—	—	—	—	—	—	—	—	—	—	—	—	—
Initial Value	0	0	0	0	0	0	0	0	0	0	0	0	0	0	0	0
R/W	R	R	R	R	R	R	R	R	R	R	R	R	R	R	R	R
Bit	15	14	13	12	11	10	9	8	7	6	5	4	3	2	1	0
	—	—	—	—	—	—	—	—	—	—	—	—	—	—	—	CLK0_MON
Initial Value	0	0	0	0	0	0	0	0	0	0	0	0	0	0	0	0
R/W	R	R	R	R	R	R	R	R	R	R	R	R	R	R	R	R

Bit	Bit Name	Initial Value	R/W	Description
31 to 1	—	All 0	R	Reserved Whenever it is read, 0 is read. The written value will be ignored.
0	CLK0_MON	0b	R	The state of the POE3_CLKM_POE clock is monitored. 0: Clock is not supplied. 1: Clock is supplied.

7.2.4.55 Clock Monitor Register WDT (CPG_CLKMON_WDT)

This register is used to monitor the state of the clocks supplied to individual modules.

Bit	31	30	29	28	27	26	25	24	23	22	21	20	19	18	17	16
	—	—	—	—	—	—	—	—	—	—	—	—	—	—	—	—
Initial Value	0	0	0	0	0	0	0	0	0	0	0	0	0	0	0	0
R/W	R	R	R	R	R	R	R	R	R	R	R	R	R	R	R	R
Bit	15	14	13	12	11	10	9	8	7	6	5	4	3	2	1	0
	—	—	—	—	—	—	—	—	—	—	—	—	—	—	CLK1_MON	CLK0_MON
Initial Value	0	0	0	0	0	0	0	0	1	1	0	0	0	0	1	1
R/W	R	R	R	R	R	R	R	R	R	R	R	R	R	R	R	R

Bit	Bit Name	Initial Value	R/W	Description
31 to 8	—	All 0	R	Reserved Whenever it is read, 0 is read. The written value will be ignored.
7	—	1b	R	Reserved When read, the initial value is read. The written value will be ignored.
6	—	1b	R	Reserved When read, the initial value is read. The written value will be ignored.
5	—	0b	R	Reserved When read, the initial value is read. The written value will be ignored.
4	—	0b	R	Reserved When read, the initial value is read. The written value will be ignored.
3, 2	—	00b	R	Reserved When read, the initial value is read. The written value will be ignored.
1	CLK1_MON	1b	R	The state of the WDT0_CLK clock is monitored. 0: Clock is not supplied. 1: Clock is supplied.
0	CLK0_MON	1b	R	The state of the WDT0_PCLK clock is monitored. 0: Clock is not supplied. 1: Clock is supplied.

7.2.4.56 Clock Monitor Register DDR (CPG_CLKMON_DDR)

This register is used to monitor the state of the clocks supplied to individual modules.

Bit	31	30	29	28	27	26	25	24	23	22	21	20	19	18	17	16
	—	—	—	—	—	—	—	—	—	—	—	—	—	—	—	—
Initial Value	0	0	0	0	0	0	0	0	0	0	0	0	0	0	0	0
R/W	R	R	R	R	R	R	R	R	R	R	R	R	R	R	R	R
Bit	15	14	13	12	11	10	9	8	7	6	5	4	3	2	1	0
	—	—	—	—	—	—	—	—	—	—	—	—	—	—	CLK1_MON	CLK0_MON
Initial Value	0	0	0	0	0	0	0	0	0	0	0	0	0	0	0	0
R/W	R	R	R	R	R	R	R	R	R	R	R	R	R	R	R	R

Bit	Bit Name	Initial Value	R/W	Description
31 to 2	—	All 0	R	Reserved Whenever it is read, 0 is read. The written value will be ignored.
1	CLK1_MON	0b	R	The state of the DDR_REG_ACLK clock is monitored. 0: Clock is not supplied. 1: Clock is supplied.
0	CLK0_MON	0b	R	The state of the DDR_PCLK clock is monitored. 0: Clock is not supplied. 1: Clock is supplied.

7.2.4.57 Clock Monitor Register SPI_MULTI (CPG_CLKMON_SPI_MULTI)

This register is used to monitor the state of the clocks supplied to individual modules.

Bit	31	30	29	28	27	26	25	24	23	22	21	20	19	18	17	16
	—	—	—	—	—	—	—	—	—	—	—	—	—	—	—	—
Initial Value	0	0	0	0	0	0	0	0	0	0	0	0	0	0	0	0
R/W	R	R	R	R	R	R	R	R	R	R	R	R	R	R	R	R
Bit	15	14	13	12	11	10	9	8	7	6	5	4	3	2	1	0
	—	—	—	—	—	—	—	—	—	—	—	—	—	—	CLK1_MON	CLK0_MON
Initial Value	0	0	0	0	0	0	0	0	0	0	0	0	0	0	0	0
R/W	R	R	R	R	R	R	R	R	R	R	R	R	R	R	R	R

Bit	Bit Name	Initial Value	R/W	Description
31 to 2	—	All 0	R	Reserved Whenever it is read, 0 is read. The written value will be ignored.
1	CLK1_MON	0b	R	The state of the SPI_CLK clock is monitored. 0: Clock is not supplied. 1: Clock is supplied.
0	CLK0_MON	0b	R	The state of the SPI_CLK2 clock is monitored. 0: Clock is not supplied. 1: Clock is supplied.

7.2.4.58 Clock Monitor Register SDHI (CPG_CLKMON_SDHI)

This register is used to monitor the state of the clocks supplied to individual modules.

Bit	31	30	29	28	27	26	25	24	23	22	21	20	19	18	17	16
	—	—	—	—	—	—	—	—	—	—	—	—	—	—	—	—
Initial Value	0	0	0	0	0	0	0	0	0	0	0	0	0	0	0	0
R/W	R	R	R	R	R	R	R	R	R	R	R	R	R	R	R	R
Bit	15	14	13	12	11	10	9	8	7	6	5	4	3	2	1	0
	—	—	—	—	—	—	—	—	CLK7_MON	CLK6_MON	CLK5_MON	CLK4_MON	CLK3_MON	CLK2_MON	CLK1_MON	CLK0_MON
Initial Value	0	0	0	0	0	0	0	0	0	0	0	0	0	0	0	0
R/W	R	R	R	R	R	R	R	R	R	R	R	R	R	R	R	R

Bit	Bit Name	Initial Value	R/W	Description
31 to 8	—	All 0	R	Reserved Whenever it is read, 0 is read. The written value will be ignored.
7	CLK7_MON	0b	R	The state of the SDHI1_ACLK clock is monitored. 0: Clock is not supplied. 1: Clock is supplied.
6	CLK6_MON	0b	R	The state of the SDHI1_CLK_HS clock is monitored. 0: Clock is not supplied. 1: Clock is supplied.
5	CLK5_MON	0b	R	The state of the SDHI1_IMCLK2 clock is monitored. 0: Clock is not supplied. 1: Clock is supplied.
4	CLK4_MON	0b	R	The state of the SDHI1_IMCLK clock is monitored. 0: Clock is not supplied. 1: Clock is supplied.
3	CLK3_MON	0b	R	The state of the SDHI0_ACLK clock is monitored. 0: Clock is not supplied. 1: Clock is supplied.
2	CLK2_MON	0b	R	The state of the SDHI0_CLK_HS clock is monitored. 0: Clock is not supplied. 1: Clock is supplied.
1	CLK1_MON	0b	R	The state of the SDHI0_IMCLK2 clock is monitored. 0: Clock is not supplied. 1: Clock is supplied.
0	CLK0_MON	0b	R	The state of the SDHI0_IMCLK clock is monitored. 0: Clock is not supplied. 1: Clock is supplied.

7.2.4.59 Clock Monitor Register SSI (CPG_CLKMON_SSI)

This register is used to monitor the state of the clocks supplied to individual modules.

Bit	31	30	29	28	27	26	25	24	23	22	21	20	19	18	17	16
	—	—	—	—	—	—	—	—	—	—	—	—	—	—	—	—
Initial Value	0	0	0	0	0	0	0	0	0	0	0	0	0	0	0	0
R/W	R	R	R	R	R	R	R	R	R	R	R	R	R	R	R	R
Bit	15	14	13	12	11	10	9	8	7	6	5	4	3	2	1	0
	—	—	—	—	—	—	—	—	CLK7_MON	CLK6_MON	CLK5_MON	CLK4_MON	CLK3_MON	CLK2_MON	CLK1_MON	CLK0_MON
Initial Value	0	0	0	0	0	0	0	0	0	0	0	0	0	0	0	0
R/W	R	R	R	R	R	R	R	R	R	R	R	R	R	R	R	R

Bit	Bit Name	Initial Value	R/W	Description
31 to 8	—	All 0	R	Reserved Whenever it is read, 0 is read. The written value will be ignored.
7	CLK7_MON	0b	R	The state of the SSI3_PCLK_SFR clock is monitored. 0: Clock is not supplied. 1: Clock is supplied.
6	CLK6_MON	0b	R	The state of the SSI3_PCLK2 clock is monitored. 0: Clock is not supplied. 1: Clock is supplied.
5	CLK5_MON	0b	R	The state of the SSI2_PCLK_SFR clock is monitored. 0: Clock is not supplied. 1: Clock is supplied.
4	CLK4_MON	0b	R	The state of the SSI2_PCLK2 clock is monitored. 0: Clock is not supplied. 1: Clock is supplied.
3	CLK3_MON	0b	R	The state of the SSI1_PCLK_SFR clock is monitored. 0: Clock is not supplied. 1: Clock is supplied.
2	CLK2_MON	0b	R	The state of the SSI1_PCLK2 clock is monitored. 0: Clock is not supplied. 1: Clock is supplied.
1	CLK1_MON	0b	R	The state of the SSI0_PCLK_SFR clock is monitored. 0: Clock is not supplied. 1: Clock is supplied.
0	CLK0_MON	0b	R	The state of the SSI0_PCLK2 clock is monitored. 0: Clock is not supplied. 1: Clock is supplied.

7.2.4.60 Clock Monitor Register USB (CPG_CLKMON_USB)

This register is used to monitor the state of the clocks supplied to individual modules.

Bit	31	30	29	28	27	26	25	24	23	22	21	20	19	18	17	16
	—	—	—	—	—	—	—	—	—	—	—	—	—	—	—	—
Initial Value	0	0	0	0	0	0	0	0	0	0	0	0	0	0	0	0
R/W	R	R	R	R	R	R	R	R	R	R	R	R	R	R	R	R
Bit	15	14	13	12	11	10	9	8	7	6	5	4	3	2	1	0
	—	—	—	—	—	—	—	—	—	—	—	—	CLK3_MON	CLK2_MON	CLK1_MON	CLK0_MON
Initial Value	0	0	0	0	0	0	0	0	0	0	0	0	0	0	0	0
R/W	R	R	R	R	R	R	R	R	R	R	R	R	R	R	R	R

Bit	Bit Name	Initial Value	R/W	Description
31 to 4	—	All 0	R	Reserved Whenever it is read, 0 is read. The written value will be ignored.
3	CLK3_MON	0b	R	The state of the USB_PCLK clock is monitored. 0: Clock is not supplied. 1: Clock is supplied.
2	CLK2_MON	0b	R	The state of the USB_U2P_EXR_CPUCLK clock is monitored. 0: Clock is not supplied. 1: Clock is supplied.
1	CLK1_MON	0b	R	The state of the USB_U2H1_HCLK clock is monitored. 0: Clock is not supplied. 1: Clock is supplied.
0	CLK0_MON	0b	R	The state of the USB_U2H0_HCLK clock is monitored. 0: Clock is not supplied. 1: Clock is supplied.

7.2.4.61 Clock Monitor Register ETH (CPG_CLKMON_ETH)

This register is used to monitor the state of the clocks supplied to individual modules.

Bit	31	30	29	28	27	26	25	24	23	22	21	20	19	18	17	16
	—	—	—	—	—	—	—	—	—	—	—	—	—	—	—	—
Initial Value	0	0	0	0	0	0	0	0	0	0	0	0	0	0	0	0
R/W	R	R	R	R	R	R	R	R	R	R	R	R	R	R	R	R
Bit	15	14	13	12	11	10	9	8	7	6	5	4	3	2	1	0
	—	—	—	—	—	—	—	—	—	—	—	—	—	—	CLK1_MON	CLK0_MON
Initial Value	0	0	0	0	0	0	0	0	0	0	0	0	0	0	0	0
R/W	R	R	R	R	R	R	R	R	R	R	R	R	R	R	R	R

Bit	Bit Name	Initial Value	R/W	Description
31 to 2	—	All 0	R	Reserved Whenever it is read, 0 is read. The written value will be ignored.
1	CLK1_MON	0b	R	The state of the ETH1_CLK_AXI/CHI clock is monitored. 0: Clock is not supplied. 1: Clock is supplied.
0	CLK0_MON	0b	R	The state of the ETH0_CLK_AXI/CHI clock is monitored. 0: Clock is not supplied. 1: Clock is supplied.

Note: No CGC is provided for ETH1_REFCLK and ETH0_REFCLK.

7.2.4.62 Clock Monitor Register I2C (CPG_CLKMON_I2C)

This register is used to monitor the state of the clocks supplied to individual modules.

Bit	31	30	29	28	27	26	25	24	23	22	21	20	19	18	17	16
	—	—	—	—	—	—	—	—	—	—	—	—	—	—	—	—
Initial Value	0	0	0	0	0	0	0	0	0	0	0	0	0	0	0	0
R/W	R	R	R	R	R	R	R	R	R	R	R	R	R	R	R	R
Bit	15	14	13	12	11	10	9	8	7	6	5	4	3	2	1	0
	—	—	—	—	—	—	—	—	—	—	—	—	CLK3_MON	CLK2_MON	CLK1_MON	CLK0_MON
Initial Value	0	0	0	0	0	0	0	0	0	0	0	0	0	0	0	0
R/W	R	R	R	R	R	R	R	R	R	R	R	R	R	R	R	R

Bit	Bit Name	Initial Value	R/W	Description
31 to 4	—	All 0	R	Reserved Whenever it is read, 0 is read. The written value will be ignored.
3	CLK3_MON	0b	R	The state of the I2C3_PCLK clock is monitored. 0: Clock is not supplied. 1: Clock is supplied.
2	CLK2_MON	0b	R	The state of the I2C2_PCLK clock is monitored. 0: Clock is not supplied. 1: Clock is supplied.
1	CLK1_MON	0b	R	The state of the I2C1_PCLK clock is monitored. 0: Clock is not supplied. 1: Clock is supplied.
0	CLK0_MON	0b	R	The state of the I2C0_PCLK clock is monitored. 0: Clock is not supplied. 1: Clock is supplied.

7.2.4.63 Clock Monitor Register SCIF (CPG_CLKMON_SCIF)

This register is used to monitor the state of the clocks supplied to individual modules.

Bit	31	30	29	28	27	26	25	24	23	22	21	20	19	18	17	16
	—	—	—	—	—	—	—	—	—	—	—	—	—	—	—	—
Initial Value	0	0	0	0	0	0	0	0	0	0	0	0	0	0	0	0
R/W	R	R	R	R	R	R	R	R	R	R	R	R	R	R	R	R
Bit	15	14	13	12	11	10	9	8	7	6	5	4	3	2	1	0
	—	—	—	—	—	—	—	—	—	—	—	CLK4_MON	CLK3_MON	CLK2_MON	CLK1_MON	CLK0_MON
Initial Value	0	0	0	0	0	0	0	0	0	0	0	0	0	0	0	0
R/W	R	R	R	R	R	R	R	R	R	R	R	R	R	R	R	R

Bit	Bit Name	Initial Value	R/W	Description
31 to 5	—	All 0	R	Reserved Whenever it is read, 0 is read. The written value will be ignored.
4	CLK4_MON	0b	R	The state of the SCIF4_CLK_PCK clock is monitored. 0: Clock is not supplied. 1: Clock is supplied.
3	CLK3_MON	0b	R	The state of the SCIF3_CLK_PCK clock is monitored. 0: Clock is not supplied. 1: Clock is supplied.
2	CLK2_MON	0b	R	The state of the SCIF2_CLK_PCK clock is monitored. 0: Clock is not supplied. 1: Clock is supplied.
1	CLK1_MON	0b	R	The state of the SCIF1_CLK_PCK clock is monitored. 0: Clock is not supplied. 1: Clock is supplied.
0	CLK0_MON	0b	R	The state of the SCIF0_CLK_PCK clock is monitored. 0: Clock is not supplied. 1: Clock is supplied.

7.2.4.64 Clock Monitor Register SCI (CPG_CLKMON_SCI)

This register is used to monitor the state of the clocks supplied to individual modules.

Bit	31	30	29	28	27	26	25	24	23	22	21	20	19	18	17	16
	—	—	—	—	—	—	—	—	—	—	—	—	—	—	—	—
Initial Value	0	0	0	0	0	0	0	0	0	0	0	0	0	0	0	0
R/W	R	R	R	R	R	R	R	R	R	R	R	R	R	R	R	R
Bit	15	14	13	12	11	10	9	8	7	6	5	4	3	2	1	0
	—	—	—	—	—	—	—	—	—	—	—	—	—	—	CLK1_MON	CLK0_MON
Initial Value	0	0	0	0	0	0	0	0	0	0	0	0	0	0	0	0
R/W	R	R	R	R	R	R	R	R	R	R	R	R	R	R	R	R

Bit	Bit Name	Initial Value	R/W	Description
31 to 2	—	All 0	R	Reserved Whenever it is read, 0 is read. The written value will be ignored..
1	CLK1_MON	0b	R	The state of the SCI1_CLKP clock is monitored. 0: Clock is not supplied. 1: Clock is supplied.
0	CLK0_MON	0b	R	The state of the SCI0_CLKP clock is monitored. 0: Clock is not supplied. 1: Clock is supplied.

7.2.4.65 Clock Monitor Register IRDA (CPG_CLKMON_IRDA)

This register is used to monitor the state of the clocks supplied to individual modules.

Bit	31	30	29	28	27	26	25	24	23	22	21	20	19	18	17	16
	—	—	—	—	—	—	—	—	—	—	—	—	—	—	—	—
Initial Value	0	0	0	0	0	0	0	0	0	0	0	0	0	0	0	0
R/W	R	R	R	R	R	R	R	R	R	R	R	R	R	R	R	R
Bit	15	14	13	12	11	10	9	8	7	6	5	4	3	2	1	0
	—	—	—	—	—	—	—	—	—	—	—	—	—	—	—	CLK0_MON
Initial Value	0	0	0	0	0	0	0	0	0	0	0	0	0	0	0	0
R/W	R	R	R	R	R	R	R	R	R	R	R	R	R	R	R	R

Bit	Bit Name	Initial Value	R/W	Description
31 to 1	—	All 0	R	Reserved Whenever it is read, 0 is read. The written value will be ignored.
0	CLK0_MON	0b	R	The state of the IRDA_CLKP clock is monitored. 0: Clock is not supplied. 1: Clock is supplied.

7.2.4.66 Clock Monitor Register RSPI (CPG_CLKMON_RSPI)

This register is used to monitor the state of the clocks supplied to individual modules.

Bit	31	30	29	28	27	26	25	24	23	22	21	20	19	18	17	16
	—	—	—	—	—	—	—	—	—	—	—	—	—	—	—	—
Initial Value	0	0	0	0	0	0	0	0	0	0	0	0	0	0	0	0
R/W	R	R	R	R	R	R	R	R	R	R	R	R	R	R	R	R
Bit	15	14	13	12	11	10	9	8	7	6	5	4	3	2	1	0
	—	—	—	—	—	—	—	—	—	—	—	—	—	CLK2_MON	CLK1_MON	CLK0_MON
Initial Value	0	0	0	0	0	0	0	0	0	0	0	0	0	0	0	0
R/W	R	R	R	R	R	R	R	R	R	R	R	R	R	R	R	R

Bit	Bit Name	Initial Value	R/W	Description
31 to 3	—	All 0	R	Reserved Whenever it is read, 0 is read. The written value will be ignored.
2	CLK2_MON	0b	R	The state of the RSPI2_CLKB clock is monitored. 0: Clock is not supplied. 1: Clock is supplied.
1	CLK1_MON	0b	R	The state of the RSPI1_CLKB clock is monitored. 0: Clock is not supplied. 1: Clock is supplied.
0	CLK0_MON	0b	R	The state of the RSPI0_CLKB clock is monitored. 0: Clock is not supplied. 1: Clock is supplied.

7.2.4.67 Clock Monitor Register CANFD (CPG_CLKMON_CANFD)

This register is used to monitor the state of the clocks supplied to individual modules.

Bit	31	30	29	28	27	26	25	24	23	22	21	20	19	18	17	16
	—	—	—	—	—	—	—	—	—	—	—	—	—	—	—	—
Initial Value	0	0	0	0	0	0	0	0	0	0	0	0	0	0	0	0
R/W	R	R	R	R	R	R	R	R	R	R	R	R	R	R	R	R
Bit	15	14	13	12	11	10	9	8	7	6	5	4	3	2	1	0
	—	—	—	—	—	—	—	—	—	—	—	—	—	—	—	CLK0_MON
Initial Value	0	0	0	0	0	0	0	0	0	0	0	0	0	0	0	0
R/W	R	R	R	R	R	R	R	R	R	R	R	R	R	R	R	R

Bit	Bit Name	Initial Value	R/W	Description
31 to 1	—	All 0	R	Reserved Whenever it is read, 0 is read. The written value will be ignored.
0	CLK0_MON	0b	R	The state of the CANFD_PCLK clock is monitored. 0: Clock is not supplied. 1: Clock is supplied.

7.2.4.68 Clock Monitor Register GPIO (CPG_CLKMON_GPIO)

This register is used to monitor the state of the clocks supplied to individual modules.

Bit	31	30	29	28	27	26	25	24	23	22	21	20	19	18	17	16
	—	—	—	—	—	—	—	—	—	—	—	—	—	—	—	—
Initial Value	0	0	0	0	0	0	0	0	0	0	0	0	0	0	0	0
R/W	R	R	R	R	R	R	R	R	R	R	R	R	R	R	R	R
Bit	15	14	13	12	11	10	9	8	7	6	5	4	3	2	1	0
	—	—	—	—	—	—	—	—	—	—	—	—	—	—	—	CLK0_MON
Initial Value	0	0	0	0	0	0	0	0	0	0	0	0	0	0	0	0
R/W	R	R	R	R	R	R	R	R	R	R	R	R	R	R	R	R

Bit	Bit Name	Initial Value	R/W	Description
31 to 1	—	All 0	R	Reserved Whenever it is read, 0 is read. The written value will be ignored.
0	CLK0_MON	0b	R	The state of the GPIO_HCLK clock is monitored. 0: Clock is not supplied. 1: Clock is supplied.

7.2.4.69 Clock Monitor Register ADC (CPG_CLKMON_ADC)

This register is used to monitor the state of the clocks supplied to individual modules.

Bit	31	30	29	28	27	26	25	24	23	22	21	20	19	18	17	16
	—	—	—	—	—	—	—	—	—	—	—	—	—	—	—	—
Initial Value	0	0	0	0	0	0	0	0	0	0	0	0	0	0	0	0
R/W	R	R	R	R	R	R	R	R	R	R	R	R	R	R	R	R
Bit	15	14	13	12	11	10	9	8	7	6	5	4	3	2	1	0
	—	—	—	—	—	—	—	—	—	—	—	—	—	—	CLK1_MON	CLK0_MON
Initial Value	0	0	0	0	0	0	0	0	0	0	0	0	0	0	0	0
R/W	R	R	R	R	R	R	R	R	R	R	R	R	R	R	R	R

Bit	Bit Name	Initial Value	R/W	Description
31 to 2	—	All 0	R	Reserved Whenever it is read, 0 is read. The written value will be ignored.
1	CLK1_MON	0b	R	The state of the ADC_PCLK clock is monitored. 0: Clock is not supplied. 1: Clock is supplied.
0	CLK0_MON	0b	R	The state of the ADC_ADCLK clock is monitored. 0: Clock is not supplied. 1: Clock is supplied.

7.2.4.70 Clock Monitor Register AX45MP (CPG_CLKMON_AX45MP)

This register is used to monitor the state of the clocks supplied to individual modules.

Bit	31	30	29	28	27	26	25	24	23	22	21	20	19	18	17	16
	—	—	—	—	—	—	—	—	—	—	—	—	—	—	—	—
Initial Value	0	0	0	0	0	0	0	0	0	0	0	0	0	0	0	0
R/W	R	R	R	R	R	R	R	R	R	R	R	R	R	R	R	R
Bit	15	14	13	12	11	10	9	8	7	6	5	4	3	2	1	0
	—	—	—	—	—	—	—	—	—	—	—	—	—	—	CLK1_MON	CLK0_MON
Initial Value	0	0	0	0	0	0	0	0	0	0	0	0	0	0	1	1
R/W	R	R	R	R	R	R	R	R	R	R	R	R	R	R	R	R

Bit	Bit Name	Initial Value	R/W	Description
31 to 2	—	All 0	R	Reserved Whenever it is read, 0 is read. The written value will be ignored.
1	CLK1_MON	1b	R	The state of the AX45MP_ACLK clock is monitored. 0: Clock is not supplied. 1: Clock is supplied.
0	CLK0_MON	1b	R	The state of the AX45MP_CORE0_CLK clock is monitored. 0: Clock is not supplied. 1: Clock is supplied.

7.2.4.71 Clock Monitor Register NCEPLDM (CPG_CLKMON_NCEPLDM)

This register is used to monitor the state of the clocks supplied to individual modules.

Bit	31	30	29	28	27	26	25	24	23	22	21	20	19	18	17	16
	—	—	—	—	—	—	—	—	—	—	—	—	—	—	—	—
Initial Value	0	0	0	0	0	0	0	0	0	0	0	0	0	0	0	0
R/W	R	R	R	R	R	R	R	R	R	R	R	R	R	R	R	R
Bit	15	14	13	12	11	10	9	8	7	6	5	4	3	2	1	0
	—	—	—	—	—	—	—	—	—	—	—	—	—	—	CLK1_MON	—
Initial Value	0	0	0	0	0	0	0	0	0	0	0	0	0	0	1	0
R/W	R	R	R	R	R	R	R	R	R	R	R	R	R	R	R	R

Bit	Bit Name	Initial Value	R/W	Description
31 to 2	—	All 0	R	Reserved Whenever it is read, 0 is read. The written value will be ignored.
1	CLK1_MON	1b	R	The state of the NCEPLDM_ACLK clock is monitored. 0: Clock is not supplied. 1: Clock is supplied.
0	CLK0_MON	0b	R	Reserved Whenever it is read, 0 is read. The written value will be ignored.

7.2.4.72 Clock Monitor Register NCEPLMT (CPG_CLKMON_NCEPLMT)

This register is used to monitor the state of the clocks supplied to individual modules.

Bit	31	30	29	28	27	26	25	24	23	22	21	20	19	18	17	16
	—	—	—	—	—	—	—	—	—	—	—	—	—	—	—	—
Initial Value	0	0	0	0	0	0	0	0	0	0	0	0	0	0	0	0
R/W	R	R	R	R	R	R	R	R	R	R	R	R	R	R	R	R
Bit	15	14	13	12	11	10	9	8	7	6	5	4	3	2	1	0
	—	—	—	—	—	—	—	—	—	—	—	—	—	—	—	CLK0_MON
Initial Value	0	0	0	0	0	0	0	0	0	0	0	0	0	0	0	1
R/W	R	R	R	R	R	R	R	R	R	R	R	R	R	R	R	R

Bit	Bit Name	Initial Value	R/W	Description
31 to 1	—	All 0	R	Reserved Whenever it is read, 0 is read. The written value will be ignored.
0	CLK0_MON	1b	R	The state of the NCEPLMT_ACLK clock is monitored. 0: Clock is not supplied. 1: Clock is supplied.

7.2.4.73 Clock Monitor Register NCEPLIC (CPG_CLKMON_NCEPLIC)

This register is used to monitor the state of the clocks supplied to individual modules.

Bit	31	30	29	28	27	26	25	24	23	22	21	20	19	18	17	16
	—	—	—	—	—	—	—	—	—	—	—	—	—	—	—	—
Initial Value	0	0	0	0	0	0	0	0	0	0	0	0	0	0	0	0
R/W	R	R	R	R	R	R	R	R	R	R	R	R	R	R	R	R
Bit	15	14	13	12	11	10	9	8	7	6	5	4	3	2	1	0
	—	—	—	—	—	—	—	—	—	—	—	—	—	—	—	CLK0_MON
Initial Value	0	0	0	0	0	0	0	0	0	0	0	0	0	0	0	1
R/W	R	R	R	R	R	R	R	R	R	R	R	R	R	R	R	R

Bit	Bit Name	Initial Value	R/W	Description
31 to 1	—	All 0	R	Reserved Whenever it is read, 0 is read. The written value will be ignored.
0	CLK0_MON	1b	R	The state of the NCEPLIC_ACLK clock is monitored. 0: Clock is not supplied. 1: Clock is supplied.

7.2.4.74 Clock Monitor Register TSU (CPG_CLKMON_TSU)

This register is used to monitor the state of the clocks supplied to individual modules.

Bit	31	30	29	28	27	26	25	24	23	22	21	20	19	18	17	16
	—	—	—	—	—	—	—	—	—	—	—	—	—	—	—	—
Initial Value	0	0	0	0	0	0	0	0	0	0	0	0	0	0	0	0
R/W	R	R	R	R	R	R	R	R	R	R	R	R	R	R	R	R
Bit	15	14	13	12	11	10	9	8	7	6	5	4	3	2	1	0
	—	—	—	—	—	—	—	—	—	—	—	—	—	—	—	CLK0_MON
Initial Value	0	0	0	0	0	0	0	0	0	0	0	0	0	0	0	0
R/W	R	R	R	R	R	R	R	R	R	R	R	R	R	R	R	R

Bit	Bit Name	Initial Value	R/W	Description
31 to 1	—	All 0	R	Reserved Whenever it is read, 0 is read. The written value will be ignored.
0	CLK0_MON	0b	R	The state of the TSU_PCLK clock is monitored. 0: Clock is not supplied. 1: Clock is supplied.

7.2.4.75 Clock Monitor Register AXI_TZCDDR (CPG_CLKMON_AXI_TZCDDR)

This register is used to monitor the state of the clocks supplied to individual modules.

Bit	31	30	29	28	27	26	25	24	23	22	21	20	19	18	17	16
	—	—	—	—	—	—	—	—	—	—	—	—	—	—	—	—
Initial Value	0	0	0	0	0	0	0	0	0	0	0	0	0	0	0	0
R/W	R	R	R	R	R	R	R	R	R	R	R	R	R	R	R	R
Bit	15	14	13	12	11	10	9	8	7	6	5	4	3	2	1	0
	—	—	—	—	—	—	—	—	—	—	—	—	—	CLK2_MON	CLK1_MON	CLK0_MON
Initial Value	0	0	0	0	0	0	0	0	0	0	0	0	0	0	0	0
R/W	R	R	R	R	R	R	R	R	R	R	R	R	R	R	R	R

Bit	Bit Name	Initial Value	R/W	Description
31 to 3	—	All 0	R	Reserved Whenever it is read, 0 is read. The written value will be ignored.
2	CLK2_MON	0b	R	The state of the BUS_TZCDDR_ACLK1 clock is monitored. 0: Clock is not supplied. 1: Clock is supplied.
1	CLK1_MON	0b	R	The state of the BUS_TZCDDR_ACLK0 clock is monitored. 0: Clock is not supplied. 1: Clock is supplied.
0	CLK0_MON	0b	R	The state of the BUS_TZCDDR_PCLK clock is monitored. 0: Clock is not supplied. 1: Clock is supplied.

7.2.4.76 Reset Control Register SRAM_ACPU (CPG_RST_SRAM_ACPU)

This register is used to control the reset signals for individual modules.

Bit	31	30	29	28	27	26	25	24	23	22	21	20	19	18	17	16
	—	—	—	—	—	—	—	—	—	—	—	—	—	—	—	UNIT0_RST_WEN
Initial Value	0	0	0	0	0	0	0	0	0	0	0	0	0	0	0	0
R/W	R	R	R	R	R	R	R	R	R	R	R	R	R	R	R	R0W1
Bit	15	14	13	12	11	10	9	8	7	6	5	4	3	2	1	0
	—	—	—	—	—	—	—	—	—	—	—	—	—	—	—	UNIT0_RSTB
Initial Value	0	0	0	0	0	0	0	0	0	0	0	0	0	0	0	1
R/W	R	R	R	R	R	R	R	R	R	R	R	R	R	R	R	RW

Bit	Bit Name	Initial Value	R/W	Description
31 to 17	—	All 0	R	Reserved Whenever it is read, 0 is read. The written value will be ignored.
16	UNIT0_RST_WEN	0b	R0W1	Flag for enabling the writing to the UNIT0_RSTB bit (bit 0) This bit is always read as 0. 0: Writing is disabled. 1: Writing is enabled.
15 to 1	—	All 0	R	Reserved Whenever it is read, 0 is read. The written value will be ignored.
0	UNIT0_RSTB	1b	RW	The SRAM_ACPU_ARESETN reset terminal is controlled. 0: Reset signal is applied (reset state). 1: Reset signal is stopped (released from the reset state).

7.2.4.77 Reset Control Register SRAM_MCPU (CPG_RST_SRAM_MCPU)

This register is used to control the reset signals for individual modules.

Bit	31	30	29	28	27	26	25	24	23	22	21	20	19	18	17	16
	—	—	—	—	—	—	—	—	—	—	—	—	—	—	—	UNIT0_RST_WEN
Initial Value	0	0	0	0	0	0	0	0	0	0	0	0	0	0	0	0
R/W	R	R	R	R	R	R	R	R	R	R	R	R	R	R	R	R0W1
Bit	15	14	13	12	11	10	9	8	7	6	5	4	3	2	1	0
	—	—	—	—	—	—	—	—	—	—	—	—	—	—	—	UNIT0_RSTB
Initial Value	0	0	0	0	0	0	0	0	0	0	0	0	0	0	0	1
R/W	R	R	R	R	R	R	R	R	R	R	R	R	R	R	R	RW

Bit	Bit Name	Initial Value	R/W	Description
31 to 17	—	All 0	R	Reserved Whenever it is read, 0 is read. The written value will be ignored.
16	UNIT0_RST_WEN	0b	R0W1	Flag for enabling the writing to the UNIT0_RSTB bit (bit 0) This bit is always read as 0. 0: Writing is disabled. 1: Writing is enabled.
15 to 1	—	All 0	R	Reserved Whenever it is read, 0 is read. The written value will be ignored.
0	UNIT0_RSTB	1b	RW	The SRAM_MCPU_ARESETN reset terminal is controlled. 0: Reset signal is applied (reset state). 1: Reset signal is stopped (released from the reset state).

7.2.4.78 Reset Control Register IAX45 (CPG_RST_IAX45)

This register is used to control the reset signals for individual modules.

Bit	31	30	29	28	27	26	25	24	23	22	21	20	19	18	17	16
	—	—	—	—	—	—	—	—	—	—	—	—	—	—	—	UNIT0_RST_WEN
Initial Value	0	0	0	0	0	0	0	0	0	0	0	0	0	0	0	0
R/W	R	R	R	R	R	R	R	R	R	R	R	R	R	R	R	R0W1
Bit	15	14	13	12	11	10	9	8	7	6	5	4	3	2	1	0
	—	—	—	—	—	—	—	—	—	—	—	—	—	—	—	UNIT0_RSTB
Initial Value	0	0	0	0	0	0	0	0	0	0	0	0	0	0	0	1
R/W	R	R	R	R	R	R	R	R	R	R	R	R	R	R	R	RW

Bit	Bit Name	Initial Value	R/W	Description
31 to 17	—	All 0	R	Reserved Whenever it is read, 0 is read. The written value will be ignored.
16	UNIT0_RST_WEN	0b	R0W1	Flag for enabling the writing to the UNIT0_RSTB bit (bit 0) This bit is always read as 0. 0: Writing is disabled. 1: Writing is enabled.
15 to 1	—	All 0	R	Reserved Whenever it is read, 0 is read. The written value will be ignored.
0	UNIT0_RSTB	1b	RW	The IAX45_RESETN reset terminal is controlled. 0: Reset signal is applied (reset state). 1: Reset signal is stopped (released from the reset state).

7.2.4.79 Reset Control Register SYC (CPG_RST_SYC)

This register is used to control the reset signals for individual modules.

Bit	31	30	29	28	27	26	25	24	23	22	21	20	19	18	17	16
	—	—	—	—	—	—	—	—	—	—	—	—	—	—	—	UNIT0_RST_WEN
Initial Value	0	0	0	0	0	0	0	0	0	0	0	0	0	0	0	0
R/W	R	R	R	R	R	R	R	R	R	R	R	R	R	R	R	R0W1
Bit	15	14	13	12	11	10	9	8	7	6	5	4	3	2	1	0
	—	—	—	—	—	—	—	—	—	—	—	—	—	—	—	UNIT0_RSTB
Initial Value	0	0	0	0	0	0	0	0	0	0	0	0	0	0	0	0
R/W	R	R	R	R	R	R	R	R	R	R	R	R	R	R	R	RW

Bit	Bit Name	Initial Value	R/W	Description
31 to 17	—	All 0	R	Reserved Whenever it is read, 0 is read. The written value will be ignored.
16	UNIT0_RST_WEN	0b	R0W1	Flag for enabling the writing to the UNIT0_RSTB bit (bit 0) This bit is always read as 0. 0: Writing is disabled. 1: Writing is enabled.
15 to 1	—	All 0	R	Reserved Whenever it is read, 0 is read. The written value will be ignored.
0	UNIT0_RSTB	0b	RW	The SYC_RESETN reset terminal is controlled. 0: Reset signal is applied (reset state). 1: Reset signal is stopped (released from the reset state).

7.2.4.80 Reset Control Register DMAC (CPG_RST_DMACH)

This register is used to control the reset signals for individual modules.

Bit	31	30	29	28	27	26	25	24	23	22	21	20	19	18	17	16
	—	—	—	—	—	—	—	—	—	—	—	—	—	—	UNIT1_RST_WEN	UNIT0_RST_WEN
Initial Value	0	0	0	0	0	0	0	0	0	0	0	0	0	0	0	0
R/W	R	R	R	R	R	R	R	R	R	R	R	R	R	R	R0W1	R0W1
Bit	15	14	13	12	11	10	9	8	7	6	5	4	3	2	1	0
	—	—	—	—	—	—	—	—	—	—	—	—	—	—	UNIT1_RSTB	UNIT0_RSTB
Initial Value	0	0	0	0	0	0	0	0	0	0	0	0	0	0	0	0
R/W	R	R	R	R	R	R	R	R	R	R	R	R	R	R	RW	RW

Bit	Bit Name	Initial Value	R/W	Description
31 to 18	—	All 0	R	Reserved Whenever it is read, 0 is read. The written value will be ignored.
17	UNIT1_RST_WEN	0b	R0W1	Flag for enabling the writing to the UNIT1_RSTB bit (bit 1) This bit is always read as 0. 0: Writing is disabled. 1: Writing is enabled.
16	UNIT0_RST_WEN	0b	R0W1	Flag for enabling the writing to the UNIT0_RSTB bit (bit 0) This bit is always read as 0. 0: Writing is disabled. 1: Writing is enabled.
15 to 2	—	All 0	R	Reserved Whenever it is read, 0 is read. The written value will be ignored.
1	UNIT1_RSTB	0b	RW	The DMAC_RST_ASYNC reset terminal is controlled. 0: Reset signal is applied (reset state). 1: Reset signal is stopped (released from the reset state).
0	UNIT0_RSTB	0b	RW	The DMAC_ARESETN reset terminal is controlled. 0: Reset signal is applied (reset state). 1: Reset signal is stopped (released from the reset state).

7.2.4.81 Reset Control Register GTM (CPG_RST_GTM)

This register is used to control the reset signals for individual modules.

Bit	31	30	29	28	27	26	25	24	23	22	21	20	19	18	17	16
	—	—	—	—	—	—	—	—	—	—	—	—	—	UNIT2_RST_WEN	UNIT1_RST_WEN	UNIT0_RST_WEN
Initial Value	0	0	0	0	0	0	0	0	0	0	0	0	0	0	0	0
R/W	R	R	R	R	R	R	R	R	R	R	R	R	R	R0W1	R0W1	R0W1
Bit	15	14	13	12	11	10	9	8	7	6	5	4	3	2	1	0
	—	—	—	—	—	—	—	—	—	—	—	—	—	UNIT2_RSTB	UNIT1_RSTB	UNIT0_RSTB
Initial Value	0	0	0	0	0	0	0	0	0	0	0	0	0	0	0	1
R/W	R	R	R	R	R	R	R	R	R	R	R	R	R	RW	RW	RW

Bit	Bit Name	Initial Value	R/W	Description
31 to 19	—	All 0	R	Reserved Whenever it is read, 0 is read. The written value will be ignored.
18	UNIT2_RST_WEN	0b	R0W1	Flag for enabling the writing to the UNIT2_RSTB bit (bit 2) This bit is always read as 0. 0: Writing is disabled. 1: Writing is enabled.
17	UNIT1_RST_WEN	0b	R0W1	Flag for enabling the writing to the UNIT1_RSTB bit (bit 1) This bit is always read as 0. 0: Writing is disabled. 1: Writing is enabled.
16	UNIT0_RST_WEN	0b	R0W1	Flag for enabling the writing to the UNIT0_RSTB bit (bit 0) This bit is always read as 0. 0: Writing is disabled. 1: Writing is enabled.
15 to 3	—	All 0	R	Reserved Whenever it is read, 0 is read. The written value will be ignored.
2	UNIT2_RSTB	0b	RW	The OSTM2_PRESETZ reset terminal is controlled. 0: Reset signal is applied (reset state). 1: Reset signal is stopped (released from the reset state).
1	UNIT1_RSTB	0b	RW	The OSTM1_PRESETZ reset terminal is controlled. 0: Reset signal is applied (reset state). 1: Reset signal is stopped (released from the reset state).
0	UNIT0_RSTB	1b	RW	The OSTM0_PRESETZ reset terminal is controlled. 0: Reset signal is applied (reset state). 1: Reset signal is stopped (released from the reset state).

7.2.4.82 Reset Control Register MTU (CPG_RST_MTU)

This register is used to control the reset signals for individual modules.

Bit	31	30	29	28	27	26	25	24	23	22	21	20	19	18	17	16
	—	—	—	—	—	—	—	—	—	—	—	—	—	—	—	UNIT0_RST_WEN
Initial Value	0	0	0	0	0	0	0	0	0	0	0	0	0	0	0	0
R/W	R	R	R	R	R	R	R	R	R	R	R	R	R	R	R	R0W1
Bit	15	14	13	12	11	10	9	8	7	6	5	4	3	2	1	0
	—	—	—	—	—	—	—	—	—	—	—	—	—	—	—	UNIT0_RSTB
Initial Value	0	0	0	0	0	0	0	0	0	0	0	0	0	0	0	0
R/W	R	R	R	R	R	R	R	R	R	R	R	R	R	R	R	RW

Bit	Bit Name	Initial Value	R/W	Description
31 to 17	—	All 0	R	Reserved Whenever it is read, 0 is read. The written value will be ignored.
16	UNIT0_RST_WEN	0b	R0W1	Flag for enabling the writing to the UNIT0_RSTB bit (bit 0) This bit is always read as 0. 0: Writing is disabled. 1: Writing is enabled.
15 to 1	—	All 0	R	Reserved Whenever it is read, 0 is read. The written value will be ignored.
0	UNIT0_RSTB	0b	RW	The MTU_X_PRESET_MTU3 reset terminal is controlled. 0: Reset signal is applied (reset state). 1: Reset signal is stopped (released from the reset state).

7.2.4.83 Reset Control Register POE3 (CPG_RST_POE3)

This register is used to control the reset signals for individual modules.

Bit	31	30	29	28	27	26	25	24	23	22	21	20	19	18	17	16
	—	—	—	—	—	—	—	—	—	—	—	—	—	—	—	UNIT0_RST_WEN
Initial Value	0	0	0	0	0	0	0	0	0	0	0	0	0	0	0	0
R/W	R	R	R	R	R	R	R	R	R	R	R	R	R	R	R	R0W1
Bit	15	14	13	12	11	10	9	8	7	6	5	4	3	2	1	0
	—	—	—	—	—	—	—	—	—	—	—	—	—	—	—	UNIT0_RSTB
Initial Value	0	0	0	0	0	0	0	0	0	0	0	0	0	0	0	0
R/W	R	R	R	R	R	R	R	R	R	R	R	R	R	R	R	RW

Bit	Bit Name	Initial Value	R/W	Description
31 to 17	—	All 0	R	Reserved Whenever it is read, 0 is read. The written value will be ignored.
16	UNIT0_RST_WEN	0b	R0W1	Flag for enabling the writing to the UNIT0_RSTB bit (bit 0) This bit is always read as 0. 0: Writing is disabled. 1: Writing is enabled.
15 to 1	—	All 0	R	Reserved Whenever it is read, 0 is read. The written value will be ignored.
0	UNIT0_RSTB	0b	RW	The POE3_RST_M_REG reset terminal is controlled. 0: Reset signal is applied (reset state). 1: Reset signal is stopped (released from the reset state).

7.2.4.84 Reset Control Register WDT (CPG_RST_WDT)

This register is used to control the reset signals for individual modules.

Bit	31	30	29	28	27	26	25	24	23	22	21	20	19	18	17	16
	—	—	—	—	—	—	—	—	—	—	—	—	—	—	—	UNIT0_RST_WEN
Initial Value	0	0	0	0	0	0	0	0	0	0	0	0	0	0	0	0
R/W	R	R	R	R	R	R	R	R	R	R	R	R	R	R	R	R0W1
Bit	15	14	13	12	11	10	9	8	7	6	5	4	3	2	1	0
	—	—	—	—	—	—	—	—	—	—	—	—	—	—	—	UNIT0_RSTB
Initial Value	0	0	0	0	0	0	0	0	0	0	0	0	1	0	0	1
R/W	R	R	R	R	R	R	R	R	R	R	R	R	R	R	R	RW

Bit	Bit Name	Initial Value	R/W	Description
31 to 19	—	All 0	R	Reserved Whenever it is read, 0 is read. The written value will be ignored.
18	—	0b	R	Reserved When read, the initial value is read. When writing, be sure to write the initial value. Operation is not guaranteed if a value other than the initial value is written.
17	—	0b	R	Reserved When read, the initial value is read. When writing, be sure to write the initial value. Operation is not guaranteed if a value other than the initial value is written.
16	UNIT0_RST_WEN	0b	R0W1	Flag for enabling the writing to the UNIT0_RSTB bit (bit 0) This bit is always read as 0. 0: Writing is disabled. 1: Writing is enabled.
15 to 4	—	All 0	R	Reserved Whenever it is read, 0 is read. The written value will be ignored.
3	—	1b	R	Reserved When read, the initial value is read. When writing, be sure to write the initial value. Operation is not guaranteed if a value other than the initial value is written.
2	—	0b	R	Reserved When read, the initial value is read. When writing, be sure to write the initial value. Operation is not guaranteed if a value other than the initial value is written.
1	—	0b	R	Reserved When read, the initial value is read. When writing, be sure to write the initial value. Operation is not guaranteed if a value other than the initial value is written.
0	UNIT0_RSTB	1b	RW	The WDT0_PRESETN reset terminal is controlled. 0: Reset signal is applied (reset state). 1: Reset signal is stopped (released from the reset state).

7.2.4.85 Reset Control Register DDR (CPG_RST_DDR)

This register is used to control the reset signals for individual modules.

Bit	31	30	29	28	27	26	25	24	23	22	21	20	19	18	17	16
	—	—	—	—	—	—	—	—	—	UNIT6_RST_WEN	UNIT5_RST_WEN	UNIT4_RST_WEN	UNIT3_RST_WEN	UNIT2_RST_WEN	UNIT1_RST_WEN	UNIT0_RST_WEN
Initial Value	0	0	0	0	0	0	0	0	0	0	0	0	0	0	0	0
R/W	R	R	R	R	R	R	R	R	R	R0W1	R0W1	R0W1	R0W1	R0W1	R0W1	R0W1
Bit	15	14	13	12	11	10	9	8	7	6	5	4	3	2	1	0
	—	—	—	—	—	—	—	—	—	UNIT6_RSTB	UNIT5_RSTB	UNIT4_RSTB	UNIT3_RSTB	UNIT2_RSTB	UNIT1_RSTB	UNIT0_RSTB
Initial Value	0	0	0	0	0	0	0	0	0	0	0	0	0	0	0	0
R/W	R	R	R	R	R	R	R	R	R	RW	RW	RW	RW	RW	RW	RW

Bit	Bit Name	Initial Value	R/W	Description
31 to 23	—	All 0	R	Reserved Whenever it is read, 0 is read. The written value will be ignored.
22	UNIT6_RST_WEN	0b	R0W1	Flag for enabling the writing to the UNIT6_RSTB bit (bit 6) This bit is always read as 0. 0: Writing is disabled. 1: Writing is enabled.
21	UNIT5_RST_WEN	0b	R0W1	Flag for enabling the writing to the UNIT5_RSTB bit (bit 5) This bit is always read as 0. 0: Writing is disabled. 1: Writing is enabled.
20	UNIT4_RST_WEN	0b	R0W1	Flag for enabling the writing to the UNIT4_RSTB bit (bit 4) This bit is always read as 0. 0: Writing is disabled. 1: Writing is enabled.
19	UNIT3_RST_WEN	0b	R0W1	Flag for enabling the writing to the UNIT3_RSTB bit (bit 3) This bit is always read as 0. 0: Writing is disabled. 1: Writing is enabled.
18	UNIT2_RST_WEN	0b	R0W1	Flag for enabling the writing to the UNIT2_RSTB bit (bit 2) This bit is always read as 0. 0: Writing is disabled. 1: Writing is enabled.
17	UNIT1_RST_WEN	0b	R0W1	Flag for enabling the writing to the UNIT1_RSTB bit (bit 1) This bit is always read as 0. 0: Writing is disabled. 1: Writing is enabled.
16	UNIT0_RST_WEN	0b	R0W1	Flag for enabling the writing to the UNIT0_RSTB bit (bit 0) This bit is always read as 0. 0: Writing is disabled. 1: Writing is enabled.
15 to 7	—	All 0	R	Reserved Whenever it is read, 0 is read. The written value will be ignored.
6	UNIT6_RSTB	0b	RW	The DDR_REG_ARESETN reset terminal is controlled. 0: Reset signal is applied (reset state). 1: Reset signal is stopped (released from the reset state).

Bit	Bit Name	Initial Value	R/W	Description
5	UNIT5_RSTB	0b	RW	The DDR_AXI3_ARESETN reset terminal is controlled. 0: Reset signal is applied (reset state). 1: Reset signal is stopped (released from the reset state).
4	UNIT4_RSTB	0b	RW	The DDR_AXI2_ARESETN reset terminal is controlled. 0: Reset signal is applied (reset state). 1: Reset signal is stopped (released from the reset state).
3	UNIT3_RSTB	0b	RW	The DDR_AXI1_ARESETN reset terminal is controlled. 0: Reset signal is applied (reset state). 1: Reset signal is stopped (released from the reset state).
2	UNIT2_RSTB	0b	RW	The DDR_AXI0_ARESETN reset terminal is controlled. 0: Reset signal is applied (reset state). 1: Reset signal is stopped (released from the reset state).
1	UNIT1_RSTB	0b	RW	The DDR_PRESETN reset terminal is controlled. 0: Reset signal is applied (reset state). 1: Reset signal is stopped (released from the reset state).
0	UNIT0_RSTB	0b	RW	The DDR_RESET_N reset terminal is controlled. 0: Reset signal is applied (reset state). 1: Reset signal is stopped (released from the reset state).

7.2.4.86 Reset Control Register SPI (CPG_RST_SPI)

This register is used to control the reset signals for individual modules.

Bit	31	30	29	28	27	26	25	24	23	22	21	20	19	18	17	16
	—	—	—	—	—	—	—	—	—	—	—	—	—	—	—	UNIT0_RST_WEN
Initial Value	0	0	0	0	0	0	0	0	0	0	0	0	0	0	0	0
R/W	R	R	R	R	R	R	R	R	R	R	R	R	R	R	R	R0W1
Bit	15	14	13	12	11	10	9	8	7	6	5	4	3	2	1	0
	—	—	—	—	—	—	—	—	—	—	—	—	—	—	—	UNIT0_RSTB
Initial Value	0	0	0	0	0	0	0	0	0	0	0	0	0	0	0	0
R/W	R	R	R	R	R	R	R	R	R	R	R	R	R	R	R	RW

Bit	Bit Name	Initial Value	R/W	Description
31 to 17	—	All 0	R	Reserved Whenever it is read, 0 is read. The written value will be ignored.
16	UNIT0_RST_WEN	0b	R0W1	Flag for enabling the writing to the UNIT0_RSTB bit (bit 0) This bit is always read as 0. 0: Writing is disabled. 1: Writing is enabled.
15 to 1	—	All 0	R	Reserved Whenever it is read, 0 is read. The written value will be ignored.
0	UNIT0_RSTB	0b	RW	The SPI_RST reset terminal is controlled. 0: Reset signal is applied (reset state). 1: Reset signal is stopped (released from the reset state).

7.2.4.87 Reset Control Register SDHI (CPG_RST_SDHI)

This register is used to control the reset signals for individual modules.

Bit	31	30	29	28	27	26	25	24	23	22	21	20	19	18	17	16
	—	—	—	—	—	—	—	—	—	—	—	—	—	—	UNIT1_RST_WEN	UNIT0_RST_WEN
Initial Value	0	0	0	0	0	0	0	0	0	0	0	0	0	0	0	0
R/W	R	R	R	R	R	R	R	R	R	R	R	R	R	R	R0W1	R0W1
Bit	15	14	13	12	11	10	9	8	7	6	5	4	3	2	1	0
	—	—	—	—	—	—	—	—	—	—	—	—	—	—	UNIT1_RSTB	UNIT0_RSTB
Initial Value	0	0	0	0	0	0	0	0	0	0	0	0	0	0	0	0
R/W	R	R	R	R	R	R	R	R	R	R	R	R	R	R	RW	RW

Bit	Bit Name	Initial Value	R/W	Description
31 to 18	—	All 0	R	Reserved Whenever it is read, 0 is read. The written value will be ignored.
17	UNIT1_RST_WEN	0b	R0W1	Flag for enabling the writing to the UNIT1_RSTB bit (bit 1) This bit is always read as 0. 0: Writing is disabled. 1: Writing is enabled.
16	UNIT0_RST_WEN	0b	R0W1	Flag for enabling the writing to the UNIT0_RSTB bit (bit 0) This bit is always read as 0. 0: Writing is disabled. 1: Writing is enabled.
15 to 2	—	All 0	R	Reserved Whenever it is read, 0 is read. The written value will be ignored.
1	UNIT1_RSTB	0b	RW	The SDHI1_IXRST reset terminal is controlled. 0: Reset signal is applied (reset state). 1: Reset signal is stopped (released from the reset state).
0	UNIT0_RSTB	0b	RW	The SDHI0_IXRST reset terminal is controlled. 0: Reset signal is applied (reset state). 1: Reset signal is stopped (released from the reset state).

7.2.4.88 Reset Control Register SSIF (CPG_RST_SSIF)

This register is used to control the reset signals for individual modules.

Bit	31	30	29	28	27	26	25	24	23	22	21	20	19	18	17	16
	—	—	—	—	—	—	—	—	—	—	—	—	UNIT3_RST_WEN	UNIT2_RST_WEN	UNIT1_RST_WEN	UNIT0_RST_WEN
Initial Value	0	0	0	0	0	0	0	0	0	0	0	0	0	0	0	0
R/W	R	R	R	R	R	R	R	R	R	R	R	R	R0W1	R0W1	R0W1	R0W1
Bit	15	14	13	12	11	10	9	8	7	6	5	4	3	2	1	0
	—	—	—	—	—	—	—	—	—	—	—	—	UNIT3_RSTB	UNIT2_RSTB	UNIT1_RSTB	UNIT0_RSTB
Initial Value	0	0	0	0	0	0	0	0	0	0	0	0	0	0	0	0
R/W	R	R	R	R	R	R	R	R	R	R	R	R	RW	RW	RW	RW

Bit	Bit Name	Initial Value	R/W	Description
31 to 20	—	All 0	R	Reserved Whenever it is read, 0 is read. The written value will be ignored.
19	UNIT3_RST_WEN	0b	R0W1	Flag for enabling the writing to the UNIT3_RSTB bit (bit 3) This bit is always read as 0. 0: Writing is disabled. 1: Writing is enabled.
18	UNIT2_RST_WEN	0b	R0W1	Flag for enabling the writing to the UNIT2_RSTB bit (bit 2) This bit is always read as 0. 0: Writing is disabled. 1: Writing is enabled.
17	UNIT1_RST_WEN	0b	R0W1	Flag for enabling the writing to the UNIT1_RSTB bit (bit 1) This bit is always read as 0. 0: Writing is disabled. 1: Writing is enabled.
16	UNIT0_RST_WEN	0b	R0W1	Flag for enabling the writing to the UNIT0_RSTB bit (bit 0) This bit is always read as 0. 0: Writing is disabled. 1: Writing is enabled.
15 to 4	—	All 0	R	Reserved Whenever it is read, 0 is read. The written value will be ignored.
3	UNIT3_RSTB	0b	RW	The SSI3_RST_M2_REG reset terminal is controlled. 0: Reset signal is applied (reset state). 1: Reset signal is stopped (released from the reset state).
2	UNIT2_RSTB	0b	RW	The SSI2_RST_M2_REG reset terminal is controlled. 0: Reset signal is applied (reset state). 1: Reset signal is stopped (released from the reset state).
1	UNIT1_RSTB	0b	RW	The SSI1_RST_M2_REG reset terminal is controlled. 0: Reset signal is applied (reset state). 1: Reset signal is stopped (released from the reset state).
0	UNIT0_RSTB	0b	RW	The SSI0_RST_M2_REG reset terminal is controlled. 0: Reset signal is applied (reset state). 1: Reset signal is stopped (released from the reset state).

7.2.4.89 Reset Control Register USB (CPG_RST_USB)

This register is used to control the reset signals for individual modules.

Bit	31	30	29	28	27	26	25	24	23	22	21	20	19	18	17	16
	—	—	—	—	—	—	—	—	—	—	—	—	UNIT3_RST_WEN	UNIT2_RST_WEN	UNIT1_RST_WEN	UNIT0_RST_WEN
Initial Value	0	0	0	0	0	0	0	0	0	0	0	0	0	0	0	0
R/W	R	R	R	R	R	R	R	R	R	R	R	R	R0W1	R0W1	R0W1	R0W1
Bit	15	14	13	12	11	10	9	8	7	6	5	4	3	2	1	0
	—	—	—	—	—	—	—	—	—	—	—	—	UNIT3_RSTB	UNIT2_RSTB	UNIT1_RSTB	UNIT0_RSTB
Initial Value	0	0	0	0	0	0	0	0	0	0	0	0	0	0	0	0
R/W	R	R	R	R	R	R	R	R	R	R	R	R	RW	RW	RW	RW

Bit	Bit Name	Initial Value	R/W	Description
31 to 20	—	All 0	R	Reserved Whenever it is read, 0 is read. The written value will be ignored.
19	UNIT3_RST_WEN	0b	R0W1	Flag for enabling the writing to the UNIT3_RSTB bit (bit 3) This bit is always read as 0. 0: Writing is disabled. 1: Writing is enabled.
18	UNIT2_RST_WEN	0b	R0W1	Flag for enabling the writing to the UNIT2_RSTB bit (bit 2) This bit is always read as 0. 0: Writing is disabled. 1: Writing is enabled.
17	UNIT1_RST_WEN	0b	R0W1	Flag for enabling the writing to the UNIT1_RSTB bit (bit 1) This bit is always read as 0. 0: Writing is disabled. 1: Writing is enabled.
16	UNIT0_RST_WEN	0b	R0W1	Flag for enabling the writing to the UNIT0_RSTB bit (bit 0) This bit is always read as 0. 0: Writing is disabled. 1: Writing is enabled.
15 to 4	—	All 0	R	Reserved Whenever it is read, 0 is read. The written value will be ignored.
3	UNIT3_RSTB	0b	RW	The USB_PRESETN reset terminal is controlled. 0: Reset signal is applied (reset state). 1: Reset signal is stopped (released from the reset state).
2	UNIT2_RSTB	0b	RW	The USB_U2P_EXL_SYSRST reset terminal is controlled. 0: Reset signal is applied (reset state). 1: Reset signal is stopped (released from the reset state).
1	UNIT1_RSTB	0b	RW	The USB_U2H1_HRESETN reset terminal is controlled. 0: Reset signal is applied (reset state). 1: Reset signal is stopped (released from the reset state).
0	UNIT0_RSTB	0b	RW	The USB_U2H0_HRESETN reset terminal is controlled. 0: Reset signal is applied (reset state). 1: Reset signal is stopped (released from the reset state).

7.2.4.90 Reset Control Register ETH (CPG_RST_ETH)

This register is used to control the reset signals for individual modules.

Bit	31	30	29	28	27	26	25	24	23	22	21	20	19	18	17	16
	—	—	—	—	—	—	—	—	—	—	—	—	—	—	UNIT1_RST_WEN	UNIT0_RST_WEN
Initial Value	0	0	0	0	0	0	0	0	0	0	0	0	0	0	0	0
R/W	R	R	R	R	R	R	R	R	R	R	R	R	R	R	R0W1	R0W1
Bit	15	14	13	12	11	10	9	8	7	6	5	4	3	2	1	0
	—	—	—	—	—	—	—	—	—	—	—	—	—	—	UNIT1_RSTB	UNIT0_RSTB
Initial Value	0	0	0	0	0	0	0	0	0	0	0	0	0	0	0	0
R/W	R	R	R	R	R	R	R	R	R	R	R	R	R	R	RW	RW

Bit	Bit Name	Initial Value	R/W	Description
31 to 18	—	All 0	R	Reserved Whenever it is read, 0 is read. The written value will be ignored.
17	UNIT1_RST_WEN	0b	R0W1	Flag for enabling the writing to the UNIT1_RSTB bit (bit 1) This bit is always read as 0. 0: Writing is disabled. 1: Writing is enabled.
16	UNIT0_RST_WEN	0b	R0W1	Flag for enabling the writing to the UNIT0_RSTB bit (bit 0) This bit is always read as 0. 0: Writing is disabled. 1: Writing is enabled.
15 to 2	—	All 0	R	Reserved Whenever it is read, 0 is read. The written value will be ignored.
1	UNIT1_RSTB	0b	RW	The ETH1_RST_HW_N reset terminal is controlled. 0: Reset signal is applied (reset state). 1: Reset signal is stopped (released from the reset state).
0	UNIT0_RSTB	0b	RW	The ETH0_RST_HW_N reset terminal is controlled. 0: Reset signal is applied (reset state). 1: Reset signal is stopped (released from the reset state).

7.2.4.91 Reset Control Register I2C (CPG_RST_I2C)

This register is used to control the reset signals for individual modules.

Bit	31	30	29	28	27	26	25	24	23	22	21	20	19	18	17	16
	—	—	—	—	—	—	—	—	—	—	—	—	UNIT3_RST_WEN	UNIT2_RST_WEN	UNIT1_RST_WEN	UNIT0_RST_WEN
Initial Value	0	0	0	0	0	0	0	0	0	0	0	0	0	0	0	0
R/W	R	R	R	R	R	R	R	R	R	R	R	R	R0W1	R0W1	R0W1	R0W1
Bit	15	14	13	12	11	10	9	8	7	6	5	4	3	2	1	0
	—	—	—	—	—	—	—	—	—	—	—	—	UNIT3_RSTB	UNIT2_RSTB	UNIT1_RSTB	UNIT0_RSTB
Initial Value	0	0	0	0	0	0	0	0	0	0	0	0	0	0	0	0
R/W	R	R	R	R	R	R	R	R	R	R	R	R	RW	RW	RW	RW

Bit	Bit Name	Initial Value	R/W	Description
31 to 20	—	All 0	R	Reserved Whenever it is read, 0 is read. The written value will be ignored.
19	UNIT3_RST_WEN	0b	R0W1	Flag for enabling the writing to the UNIT3_RSTB bit (bit 3) This bit is always read as 0. 0: Writing is disabled. 1: Writing is enabled.
18	UNIT2_RST_WEN	0b	R0W1	Flag for enabling the writing to the UNIT2_RSTB bit (bit 2) This bit is always read as 0. 0: Writing is disabled. 1: Writing is enabled.
17	UNIT1_RST_WEN	0b	R0W1	Flag for enabling the writing to the UNIT1_RSTB bit (bit 1) This bit is always read as 0. 0: Writing is disabled. 1: Writing is enabled.
16	UNIT0_RST_WEN	0b	R0W1	Flag for enabling the writing to the UNIT0_RSTB bit (bit 0) This bit is always read as 0. 0: Writing is disabled. 1: Writing is enabled.
15 to 4	—	All 0	R	Reserved Whenever it is read, 0 is read. The written value will be ignored.
3	UNIT3_RSTB	0b	RW	The I2C3_MRST reset terminal is controlled. 0: Reset signal is applied (reset state). 1: Reset signal is stopped (released from the reset state).
2	UNIT2_RSTB	0b	RW	The I2C2_MRST reset terminal is controlled. 0: Reset signal is applied (reset state). 1: Reset signal is stopped (released from the reset state).
1	UNIT1_RSTB	0b	RW	The I2C1_MRST reset terminal is controlled. 0: Reset signal is applied (reset state). 1: Reset signal is stopped (released from the reset state).
0	UNIT0_RSTB	0b	RW	The I2C0_MRST reset terminal is controlled. 0: Reset signal is applied (reset state). 1: Reset signal is stopped (released from the reset state).

7.2.4.92 Reset Control Register SCIF (CPG_RST_SCIF)

This register is used to control the reset signals for individual modules.

Bit	31	30	29	28	27	26	25	24	23	22	21	20	19	18	17	16
	—	—	—	—	—	—	—	—	—	—	—	UNIT4_RST_WEN	UNIT3_RST_WEN	UNIT2_RST_WEN	UNIT1_RST_WEN	UNIT0_RST_WEN
Initial Value	0	0	0	0	0	0	0	0	0	0	0	0	0	0	0	0
R/W	R	R	R	R	R	R	R	R	R	R	R	R0W1	R0W1	R0W1	R0W1	R0W1
Bit	15	14	13	12	11	10	9	8	7	6	5	4	3	2	1	0
	—	—	—	—	—	—	—	—	—	—	—	UNIT4_RSTB	UNIT3_RSTB	UNIT2_RSTB	UNIT1_RSTB	UNIT0_RSTB
Initial Value	0	0	0	0	0	0	0	0	0	0	0	0	0	0	0	0
R/W	R	R	R	R	R	R	R	R	R	R	R	RW	RW	RW	RW	RW

Bit	Bit Name	Initial Value	R/W	Description
31 to 21	—	All 0	R	Reserved Whenever it is read, 0 is read. The written value will be ignored.
20	UNIT4_RST_WEN	0b	R0W1	Flag for enabling the writing to the UNIT4_RSTB bit (bit 4) This bit is always read as 0. 0: Writing is disabled. 1: Writing is enabled.
19	UNIT3_RST_WEN	0b	R0W1	Flag for enabling the writing to the UNIT3_RSTB bit (bit 3) This bit is always read as 0. 0: Writing is disabled. 1: Writing is enabled.
18	UNIT2_RST_WEN	0b	R0W1	Flag for enabling the writing to the UNIT2_RSTB bit (bit 2) This bit is always read as 0. 0: Writing is disabled. 1: Writing is enabled.
17	UNIT1_RST_WEN	0b	R0W1	Flag for enabling the writing to the UNIT1_RSTB bit (bit 1) This bit is always read as 0. 0: Writing is disabled. 1: Writing is enabled.
16	UNIT0_RST_WEN	0b	R0W1	Flag for enabling the writing to the UNIT0_RSTB bit (bit 0) This bit is always read as 0. 0: Writing is disabled. 1: Writing is enabled.
15 to 5	—	All 0	R	Reserved Whenever it is read, 0 is read. The written value will be ignored.
4	UNIT4_RSTB	0b	RW	The SCIF4_RST_SYSTEM_N reset terminal is controlled. 0: Reset signal is applied (reset state). 1: Reset signal is stopped (released from the reset state).
3	UNIT3_RSTB	0b	RW	The SCIF3_RST_SYSTEM_N reset terminal is controlled. 0: Reset signal is applied (reset state). 1: Reset signal is stopped (released from the reset state).
2	UNIT2_RSTB	0b	RW	The SCIF2_RST_SYSTEM_N reset terminal is controlled. 0: Reset signal is applied (reset state). 1: Reset signal is stopped (released from the reset state).
1	UNIT1_RSTB	0b	RW	The SCIF1_RST_SYSTEM_N reset terminal is controlled. 0: Reset signal is applied (reset state). 1: Reset signal is stopped (released from the reset state).

Bit	Bit Name	Initial Value	R/W	Description
0	UNIT0_RSTB	0b	RW	The SCIF0_RST_SYSTEM_N reset terminal is controlled. 0: Reset signal is applied (reset state). 1: Reset signal is stopped (released from the reset state).

7.2.4.93 Reset Control Register SCI (CPG_RST_SCI)

This register is used to control the reset signals for individual modules.

Bit	31	30	29	28	27	26	25	24	23	22	21	20	19	18	17	16
	—	—	—	—	—	—	—	—	—	—	—	—	—	—	UNIT1_RST_WEN	UNIT0_RST_WEN
Initial Value	0	0	0	0	0	0	0	0	0	0	0	0	0	0	0	0
R/W	R	R	R	R	R	R	R	R	R	R	R	R	R	R	R0W1	R0W1
Bit	15	14	13	12	11	10	9	8	7	6	5	4	3	2	1	0
	—	—	—	—	—	—	—	—	—	—	—	—	—	—	UNIT1_RSTB	UNIT0_RSTB
Initial Value	0	0	0	0	0	0	0	0	0	0	0	0	0	0	0	0
R/W	R	R	R	R	R	R	R	R	R	R	R	R	R	R	RW	RW

Bit	Bit Name	Initial Value	R/W	Description
31 to 18	—	All 0	R	Reserved Whenever it is read, 0 is read. The written value will be ignored.
17	UNIT1_RST_WEN	0b	R0W1	Flag for enabling the writing to the UNIT1_RSTB bit (bit 1) This bit is always read as 0. 0: Writing is disabled. 1: Writing is enabled.
16	UNIT0_RST_WEN	0b	R0W1	Flag for enabling the writing to the UNIT0_RSTB bit (bit 0) This bit is always read as 0. 0: Writing is disabled. 1: Writing is enabled.
15 to 2	—	All 0	R	Reserved Whenever it is read, 0 is read. The written value will be ignored.
1	UNIT1_RSTB	0b	RW	The SCI1_RST reset terminal is controlled. 0: Reset signal is applied (reset state). 1: Reset signal is stopped (released from the reset state).
0	UNIT0_RSTB	0b	RW	The SCI0_RST reset terminal is controlled. 0: Reset signal is applied (reset state). 1: Reset signal is stopped (released from the reset state).

7.2.4.94 Reset Control Register IRDA (CPG_RST_IRDA)

This register is used to control the reset signals for individual modules.

Bit	31	30	29	28	27	26	25	24	23	22	21	20	19	18	17	16
	—	—	—	—	—	—	—	—	—	—	—	—	—	—	—	UNIT0_RST_WEN
Initial Value	0	0	0	0	0	0	0	0	0	0	0	0	0	0	0	0
R/W	R	R	R	R	R	R	R	R	R	R	R	R	R	R	R	R0W1
Bit	15	14	13	12	11	10	9	8	7	6	5	4	3	2	1	0
	—	—	—	—	—	—	—	—	—	—	—	—	—	—	—	UNIT0_RSTB
Initial Value	0	0	0	0	0	0	0	0	0	0	0	0	0	0	0	0
R/W	R	R	R	R	R	R	R	R	R	R	R	R	R	R	R	RW

Bit	Bit Name	Initial Value	R/W	Description
31 to 17	—	All 0	R	Reserved Whenever it is read, 0 is read. The written value will be ignored.
16	UNIT0_RST_WEN	0b	R0W1	Flag for enabling the writing to the UNIT0_RSTB bit (bit 0) This bit is always read as 0. 0: Writing is disabled. 1: Writing is enabled.
15 to 1	—	All 0	R	Reserved Whenever it is read, 0 is read. The written value will be ignored.
0	UNIT0_RSTB	0b	RW	The IRDA_RST reset terminal is controlled. 0: Reset signal is applied (reset state). 1: Reset signal is stopped (released from the reset state).

7.2.4.95 Reset Control Register RSPI (CPG_RST_RSPI)

This register is used to control the reset signals for individual modules.

Bit	31	30	29	28	27	26	25	24	23	22	21	20	19	18	17	16
	—	—	—	—	—	—	—	—	—	—	—	—	—	UNIT2_RST_WEN	UNIT1_RST_WEN	UNIT0_RST_WEN
Initial Value	0	0	0	0	0	0	0	0	0	0	0	0	0	0	0	0
R/W	R	R	R	R	R	R	R	R	R	R	R	R	R	R0W1	R0W1	R0W1
Bit	15	14	13	12	11	10	9	8	7	6	5	4	3	2	1	0
	—	—	—	—	—	—	—	—	—	—	—	—	—	UNIT2_RSTB	UNIT1_RSTB	UNIT0_RSTB
Initial Value	0	0	0	0	0	0	0	0	0	0	0	0	0	0	0	0
R/W	R	R	R	R	R	R	R	R	R	R	R	R	R	RW	RW	RW

Bit	Bit Name	Initial Value	R/W	Description
31 to 19	—	All 0	R	Reserved Whenever it is read, 0 is read. The written value will be ignored.
18	UNIT2_RST_WEN	0b	R0W1	Flag for enabling the writing to the UNIT2_RSTB bit (bit 2) This bit is always read as 0. 0: Writing is disabled. 1: Writing is enabled.
17	UNIT1_RST_WEN	0b	R0W1	Flag for enabling the writing to the UNIT1_RSTB bit (bit 1) This bit is always read as 0. 0: Writing is disabled. 1: Writing is enabled.
16	UNIT0_RST_WEN	0b	R0W1	Flag for enabling the writing to the UNIT0_RSTB bit (bit 0) This bit is always read as 0. 0: Writing is disabled. 1: Writing is enabled.
15 to 3	—	All 0	R	Reserved Whenever it is read, 0 is read. The written value will be ignored.
2	UNIT2_RSTB	0b	RW	The RSPI2_RST reset terminal is controlled. 0: Reset signal is applied (reset state). 1: Reset signal is stopped (released from the reset state).
1	UNIT1_RSTB	0b	RW	The RSPI1_RST reset terminal is controlled. 0: Reset signal is applied (reset state). 1: Reset signal is stopped (released from the reset state).
0	UNIT0_RSTB	0b	RW	The RSPI0_RST reset terminal is controlled. 0: Reset signal is applied (reset state). 1: Reset signal is stopped (released from the reset state).

7.2.4.96 Reset Control Register CANFD (CPG_RST_CANFD)

This register is used to control the reset signals for individual modules.

Bit	31	30	29	28	27	26	25	24	23	22	21	20	19	18	17	16
	—	—	—	—	—	—	—	—	—	—	—	—	—	—	UNIT1_RST_WEN	UNIT0_RST_WEN
Initial Value	0	0	0	0	0	0	0	0	0	0	0	0	0	0	0	0
R/W	R	R	R	R	R	R	R	R	R	R	R	R	R	R	R0W1	R0W1
Bit	15	14	13	12	11	10	9	8	7	6	5	4	3	2	1	0
	—	—	—	—	—	—	—	—	—	—	—	—	—	—	UNIT1_RSTB	UNIT0_RSTB
Initial Value	0	0	0	0	0	0	0	0	0	0	0	0	0	0	0	0
R/W	R	R	R	R	R	R	R	R	R	R	R	R	R	R	RW	RW

Bit	Bit Name	Initial Value	R/W	Description
31 to 18	—	All 0	R	Reserved Whenever it is read, 0 is read. The written value will be ignored.
17	UNIT1_RST_WEN	0b	R0W1	Flag for enabling the writing to the UNIT1_RSTB bit (bit 1) This bit is always read as 0. 0: Writing is disabled. 1: Writing is enabled.
16	UNIT0_RST_WEN	0b	R0W1	Flag for enabling the writing to the UNIT0_RSTB bit (bit 0) This bit is always read as 0. 0: Writing is disabled. 1: Writing is enabled.
15 to 2	—	All 0	R	Reserved Whenever it is read, 0 is read. The written value will be ignored.
1	UNIT1_RSTB	0b	RW	The CANFD_RSTC_N reset terminal is controlled. 0: Reset signal is applied (reset state). 1: Reset signal is stopped (released from the reset state).
0	UNIT0_RSTB	0b	RW	The CANFD_RSTP_N reset terminal is controlled. 0: Reset signal is applied (reset state). 1: Reset signal is stopped (released from the reset state).

7.2.4.97 Reset Control Register GPIO (CPG_RST_GPIO)

This register is used to control the reset signals for individual modules.

Bit	31	30	29	28	27	26	25	24	23	22	21	20	19	18	17	16
	—	—	—	—	—	—	—	—	—	—	—	—	—	UNIT2_RST_WEN	UNIT1_RST_WEN	UNIT0_RST_WEN
Initial Value	0	0	0	0	0	0	0	0	0	0	0	0	0	0	0	0
R/W	R	R	R	R	R	R	R	R	R	R	R	R	R	R0W1	R0W1	R0W1
Bit	15	14	13	12	11	10	9	8	7	6	5	4	3	2	1	0
	—	—	—	—	—	—	—	—	—	—	—	—	—	UNIT2_RSTB	UNIT1_RSTB	UNIT0_RSTB
Initial Value	0	0	0	0	0	0	0	0	0	0	0	0	0	0	0	0
R/W	R	R	R	R	R	R	R	R	R	R	R	R	R	RW	RW	RW

Bit	Bit Name	Initial Value	R/W	Description
31 to 19	—	All 0	R	Reserved Whenever it is read, 0 is read. The written value will be ignored.
18	UNIT2_RST_WEN	0b	R0W1	Flag for enabling the writing to the UNIT2_RSTB bit (bit 2) This bit is always read as 0. 0: Writing is disabled. 1: Writing is enabled.
17	UNIT1_RST_WEN	0b	R0W1	Flag for enabling the writing to the UNIT1_RSTB bit (bit 1) This bit is always read as 0. 0: Writing is disabled. 1: Writing is enabled.
16	UNIT0_RST_WEN	0b	R0W1	Flag for enabling the writing to the UNIT0_RSTB bit (bit 0) This bit is always read as 0. 0: Writing is disabled. 1: Writing is enabled.
15 to 3	—	All 0	R	Reserved Whenever it is read, 0 is read. The written value will be ignored.
2	UNIT2_RSTB	0b	RW	The GPIO_SPARE_RESETN reset terminal is controlled. 0: Reset signal is applied (reset state). 1: Reset signal is stopped (released from the reset state).
1	UNIT1_RSTB	0b	RW	The GPIO_PORT_RESETN reset terminal is controlled. 0: Reset signal is applied (reset state). 1: Reset signal is stopped (released from the reset state).
0	UNIT0_RSTB	0b	RW	The GPIO_RSTN reset terminal is controlled. 0: Reset signal is applied (reset state). 1: Reset signal is stopped (released from the reset state).

7.2.4.98 Reset Control Register ADC (CPG_RST_ADC)

This register is used to control the reset signals for individual modules.

Bit	31	30	29	28	27	26	25	24	23	22	21	20	19	18	17	16
	—	—	—	—	—	—	—	—	—	—	—	—	—	—	UNIT1_RST_WEN	UNIT0_RST_WEN
Initial Value	0	0	0	0	0	0	0	0	0	0	0	0	0	0	0	0
R/W	R	R	R	R	R	R	R	R	R	R	R	R	R	R	R0W1	R0W1
Bit	15	14	13	12	11	10	9	8	7	6	5	4	3	2	1	0
	—	—	—	—	—	—	—	—	—	—	—	—	—	—	UNIT1_RSTB	UNIT0_RSTB
Initial Value	0	0	0	0	0	0	0	0	0	0	0	0	0	0	0	0
R/W	R	R	R	R	R	R	R	R	R	R	R	R	R	R	RW	RW

Bit	Bit Name	Initial Value	R/W	Description
31 to 18	—	All 0	R	Reserved Whenever it is read, 0 is read. The written value will be ignored.
17	UNIT1_RST_WEN	0b	R0W1	Flag for enabling the writing to the UNIT1_RSTB bit (bit 1) This bit is always read as 0. 0: Writing is disabled. 1: Writing is enabled.
16	UNIT0_RST_WEN	0b	R0W1	Flag for enabling the writing to the UNIT0_RSTB bit (bit 0) This bit is always read as 0. 0: Writing is disabled. 1: Writing is enabled.
15 to 2	—	All 0	R	Reserved Whenever it is read, 0 is read. The written value will be ignored.
1	UNIT1_RSTB	0b	RW	The ADC_ADRST_N reset terminal is controlled. 0: Reset signal is applied (reset state). 1: Reset signal is stopped (released from the reset state).
0	UNIT0_RSTB	0b	RW	The ADC_PRESETN reset terminal is controlled. 0: Reset signal is applied (reset state). 1: Reset signal is stopped (released from the reset state).

7.2.4.99 Reset Control Register TSU (CPG_RST_TSU)

This register is used to control the reset signals for individual modules.

Bit	31	30	29	28	27	26	25	24	23	22	21	20	19	18	17	16
	—	—	—	—	—	—	—	—	—	—	—	—	—	—	—	UNIT0_RST_WEN
Initial Value	0	0	0	0	0	0	0	0	0	0	0	0	0	0	0	0
R/W	R	R	R	R	R	R	R	R	R	R	R	R	R	R	R	R0W1
Bit	15	14	13	12	11	10	9	8	7	6	5	4	3	2	1	0
	—	—	—	—	—	—	—	—	—	—	—	—	—	—	—	UNIT0_RSTB
Initial Value	0	0	0	0	0	0	0	0	0	0	0	0	0	0	0	0
R/W	R	R	R	R	R	R	R	R	R	R	R	R	R	R	R	RW

Bit	Bit Name	Initial Value	R/W	Description
31 to 17	—	All 0	R	Reserved Whenever it is read, 0 is read. The written value will be ignored.
16	UNIT0_RST_WEN	0b	R0W1	Flag for enabling the writing to the UNIT0_RSTB bit (bit 0) This bit is always read as 0. 0: Writing is disabled. 1: Writing is enabled.
15 to 1	—	All 0	R	Reserved Whenever it is read, 0 is read. The written value will be ignored.
0	UNIT0_RSTB	0b	RW	The TSU_PRESETN reset terminal is controlled. 0: Reset signal is applied (reset state). 1: Reset signal is stopped (released from the reset state).

7.2.4.100 Reset Control Register AXI_TZCDDR (CPG_RST_AXI_TZCDDR)

This register is used to control the reset signals for individual modules.

Bit	31	30	29	28	27	26	25	24	23	22	21	20	19	18	17	16
	—	—	—	—	—	—	—	—	—	—	—	—	—	UNIT2_RST_WEN	UNIT1_RST_WEN	UNIT0_RST_WEN
Initial Value	0	0	0	0	0	0	0	0	0	0	0	0	0	0	0	0
R/W	R	R	R	R	R	R	R	R	R	R	R	R	R	R0W1	R0W1	R0W1
Bit	15	14	13	12	11	10	9	8	7	6	5	4	3	2	1	0
	—	—	—	—	—	—	—	—	—	—	—	—	—	UNIT2_RSTB	UNIT1_RSTB	UNIT0_RSTB
Initial Value	0	0	0	0	0	0	0	0	0	0	0	1	1	1	1	1
R/W	R	R	R	R	R	R	R	R	R	R	R	R	R	RW	RW	RW

Bit	Bit Name	Initial Value	R/W	Description
31 to 19	—	All 0	R	Reserved Whenever it is read, 0 is read. The written value will be ignored.
18	UNIT2_RST_WEN	0b	R0W1	Flag for enabling the writing to the UNIT2_RSTB bit (bit 2) This bit is always read as 0. 0: Writing is disabled. 1: Writing is enabled.
17	UNIT1_RST_WEN	0b	R0W1	Flag for enabling the writing to the UNIT1_RSTB bit (bit 1) This bit is always read as 0. 0: Writing is disabled. 1: Writing is enabled.
16	UNIT0_RST_WEN	0b	R0W1	Flag for enabling the writing to the UNIT0_RSTB bit (bit 0) This bit is always read as 0. 0: Writing is disabled. 1: Writing is enabled.
15 to 5	—	All 0	R	Reserved Whenever it is read, 0 is read. The written value will be ignored.
4, 3	—	11b	R	Reserved When read, the initial value is read. When writing, be sure to write the initial value. Operation is not guaranteed if a value other than the initial value is written.
2	UNIT2_RSTB	1b	RW	The BUS_TZCDDR_ARESET1N reset terminal is controlled. 0: Reset signal is applied (reset state). 1: Reset signal is stopped (released from the reset state).
1	UNIT1_RSTB	1b	RW	The BUS_TZCDDR_ARESET0N reset terminal is controlled. 0: Reset signal is applied (reset state). 1: Reset signal is stopped (released from the reset state).
0	UNIT0_RSTB	1b	RW	The BUS_TZCDDR_PRESETN reset terminal is controlled. 0: Reset signal is applied (reset state). 1: Reset signal is stopped (released from the reset state).

7.2.4.101 Reset Control Register AX45MP (CPG_RST_AX45MP)

This register is used to control the reset signals for individual modules.

Bit	31	30	29	28	27	26	25	24	23	22	21	20	19	18	17	16
	—	—	—	—	—	—	—	—	—	—	—	—	UNIT3_RST_WEN	UNIT2_RST_WEN	UNIT1_RST_WEN	UNIT0_RST_WEN
Initial Value	0	0	0	0	0	0	0	0	0	0	0	0	0	0	0	0
R/W	R	R	R	R	R	R	R	R	R	R	R	R	R0W1	R0W1	R0W1	R0W1
Bit	15	14	13	12	11	10	9	8	7	6	5	4	3	2	1	0
	—	—	—	—	—	—	—	—	—	—	—	—	UNIT3_RSTB	UNIT2_RSTB	UNIT1_RSTB	UNIT0_RSTB
Initial Value	0	0	0	0	0	0	0	0	0	0	0	0	1	1	1	1
R/W	R	R	R	R	R	R	R	R	R	R	R	R	RW	RW	RW	RW

Bit	Bit Name	Initial Value	R/W	Description
31 to 20	—	All 0	R	Reserved Whenever it is read, 0 is read. The written value will be ignored.
19	UNIT3_RST_WEN	0b	R0W1	Flag for enabling the writing to the UNIT3_RSTB bit (bit 3) This bit is always read as 0. 0: Writing is disabled. 1: Writing is enabled.
18	UNIT3_RST_WEN	0b	R0W1	Flag for enabling the writing to the UNIT2_RSTB bit (bit 2) This bit is always read as 0. 0: Writing is disabled. 1: Writing is enabled.
17	UNIT1_RST_WEN	0b	R0W1	Flag for enabling the writing to the UNIT1_RSTB bit (bit 1) This bit is always read as 0. 0: Writing is disabled. 1: Writing is enabled.
16	UNIT0_RST_WEN	0b	R0W1	Flag for enabling the writing to the UNIT0_RSTB bit (bit 0) This bit is always read as 0. 0: Writing is disabled. 1: Writing is enabled.
15 to 4	—	All 0	R	Reserved Whenever it is read, 0 is read. The written value will be ignored.
3	UNIT3_RSTB	1b	RW	The AX45MP_CORE0_RESETN reset terminal is controlled. 0: Reset signal is applied (reset state). 1: Reset signal is stopped (released from the reset state).
2	UNIT2_RSTB	1b	RW	The AX45MP_L2_RESETN reset terminal is controlled. 0: Reset signal is applied (reset state). 1: Reset signal is stopped (released from the reset state).
1	UNIT1_RSTB	1b	RW	The AX45MP_ARESETNS reset terminal is controlled. 0: Reset signal is applied (reset state). 1: Reset signal is stopped (released from the reset state).
0	UNIT0_RSTB	1b	RW	The AX45MP_ARESETNM reset terminal is controlled. 0: Reset signal is applied (reset state). 1: Reset signal is stopped (released from the reset state).

7.2.4.102 Reset Control Register NCEPLDM (CPG_RST_NCEPLDM)

This register is used to control the reset signals for individual modules.

Bit	31	30	29	28	27	26	25	24	23	22	21	20	19	18	17	16
	—	—	—	—	—	—	—	—	—	—	—	—	—	—	UNIT1_RST_WEN	UNIT0_RST_WEN
Initial Value	0	0	0	0	0	0	0	0	0	0	0	0	0	0	0	0
R/W	R	R	R	R	R	R	R	R	R	R	R	R	R	R	R0W1	R0W1
Bit	15	14	13	12	11	10	9	8	7	6	5	4	3	2	1	0
	—	—	—	—	—	—	—	—	—	—	—	—	—	—	UNIT1_RSTB	UNIT0_RSTB
Initial Value	0	0	0	0	0	0	0	0	0	0	0	0	0	0	1	1
R/W	R	R	R	R	R	R	R	R	R	R	R	R	R	R	RW	RW

Bit	Bit Name	Initial Value	R/W	Description
31 to 18	—	All 0	R	Reserved Whenever it is read, 0 is read. The written value will be ignored.
17	UNIT1_RST_WEN	0b	R0W1	Flag for enabling the writing to the UNIT1_RSTB bit (bit 1) This bit is always read as 0. 0: Writing is disabled. 1: Writing is enabled.
16	UNIT0_RST_WEN	0b	R0W1	Flag for enabling the writing to the UNIT0_RSTB bit (bit 0) This bit is always read as 0. 0: Writing is disabled. 1: Writing is enabled.
15 to 2	—	All 0	R	Reserved Whenever it is read, 0 is read. The written value will be ignored.
1	UNIT1_RSTB	1b	RW	The NCEPLDM_ARESETN reset terminal is controlled. 0: Reset signal is applied (reset state). 1: Reset signal is stopped (released from the reset state).
0	UNIT0_RSTB	1b	RW	The NCEPLDM_DTM_PWR_RST_N reset terminal is controlled. 0: Reset signal is applied (reset state). 1: Reset signal is stopped (released from the reset state).

7.2.4.103 Reset Control Register NCEPLMT (CPG_RST_NCEPLMT)

This register is used to control the reset signals for individual modules.

Bit	31	30	29	28	27	26	25	24	23	22	21	20	19	18	17	16
	—	—	—	—	—	—	—	—	—	—	—	—	—	—	UNIT1_RST_WEN	UNIT0_RST_WEN
Initial Value	0	0	0	0	0	0	0	0	0	0	0	0	0	0	0	0
R/W	R	R	R	R	R	R	R	R	R	R	R	R	R	R	R0W1	R0W1
Bit	15	14	13	12	11	10	9	8	7	6	5	4	3	2	1	0
	—	—	—	—	—	—	—	—	—	—	—	—	—	—	UNIT1_RSTB	UNIT0_RSTB
Initial Value	0	0	0	0	0	0	0	0	0	0	0	0	0	0	1	1
R/W	R	R	R	R	R	R	R	R	R	R	R	R	R	R	RW	RW

Bit	Bit Name	Initial Value	R/W	Description
31 to 18	—	All 0	R	Reserved Whenever it is read, 0 is read. The written value will be ignored.
17	UNIT1_RST_WEN	0b	R0W1	Flag for enabling the writing to the UNIT1_RSTB bit (bit 1) This bit is always read as 0. 0: Writing is disabled. 1: Writing is enabled.
16	UNIT0_RST_WEN	0b	R0W1	Flag for enabling the writing to the UNIT0_RSTB bit (bit 0) This bit is always read as 0. 0: Writing is disabled. 1: Writing is enabled.
15 to 2	—	All 0	R	Reserved Whenever it is read, 0 is read. The written value will be ignored.
1	UNIT1_RSTB	1b	RW	The NCEPLMT_ARESETN reset terminal is controlled. 0: Reset signal is applied (reset state). 1: Reset signal is stopped (released from the reset state).
0	UNIT0_RSTB	1b	RW	The NCEPLMT_POR_RSTN reset terminal is controlled. 0: Reset signal is applied (reset state). 1: Reset signal is stopped (released from the reset state).

7.2.4.104 Reset Control Register NCEPLIC (CPG_RST_NCEPLIC)

This register is used to control the reset signals for individual modules.

Bit	31	30	29	28	27	26	25	24	23	22	21	20	19	18	17	16
	—	—	—	—	—	—	—	—	—	—	—	—	—	—	—	UNIT0_RST_WEN
Initial Value	0	0	0	0	0	0	0	0	0	0	0	0	0	0	0	0
R/W	R	R	R	R	R	R	R	R	R	R	R	R	R	R	R	R0W1
Bit	15	14	13	12	11	10	9	8	7	6	5	4	3	2	1	0
	—	—	—	—	—	—	—	—	—	—	—	—	—	—	—	UNIT0_RSTB
Initial Value	0	0	0	0	0	0	0	0	0	0	0	0	0	0	0	1
R/W	R	R	R	R	R	R	R	R	R	R	R	R	R	R	R	RW

Bit	Bit Name	Initial Value	R/W	Description
31 to 17	—	All 0	R	Reserved Whenever it is read, 0 is read. The written value will be ignored.
16	UNIT0_RST_WEN	0b	R0W1	Flag for enabling the writing to the UNIT0_RSTB bit (bit 0) This bit is always read as 0. 0: Writing is disabled. 1: Writing is enabled.
15 to 1	—	All 0	R	Reserved Whenever it is read, 0 is read. The written value will be ignored.
0	UNIT0_RSTB	1b	RW	The NCEPLIC_ARESETN reset terminal is controlled. 0: Reset signal is applied (reset state). 1: Reset signal is stopped (released from the reset state).

7.2.4.105 Reset Monitor Register SRAM_ACPU (CPG_RSTMON_SRAM_ACPU)

This register is used to monitor the reset signals of individual modules.

Bit	31	30	29	28	27	26	25	24	23	22	21	20	19	18	17	16
	—	—	—	—	—	—	—	—	—	—	—	—	—	—	—	—
Initial Value	0	0	0	0	0	0	0	0	0	0	0	0	0	0	0	0
R/W	R	R	R	R	R	R	R	R	R	R	R	R	R	R	R	R
Bit	15	14	13	12	11	10	9	8	7	6	5	4	3	2	1	0
	—	—	—	—	—	—	—	—	—	—	—	—	—	—	—	RST0_MON
Initial Value	0	0	0	0	0	0	0	0	0	0	0	0	0	0	0	0
R/W	R	R	R	R	R	R	R	R	R	R	R	R	R	R	R	R

Bit	Bit Name	Initial Value	R/W	Description
31 to 1	—	All 0	R	Reserved Whenever it is read, 0 is read. The written value will be ignored.
0	RST0_MON	0b	R	The state of the SRAM_ACPU_ARESETN reset signal is monitored. 0: Reset signal is not applied (released from the reset state). 1: Reset signal is applied (reset state).

7.2.4.106 Reset Monitor Register SRAM_MCPU (CPG_RSTMON_SRAM_MCPU)

This register is used to monitor the reset signals of individual modules.

Bit	31	30	29	28	27	26	25	24	23	22	21	20	19	18	17	16
	—	—	—	—	—	—	—	—	—	—	—	—	—	—	—	—
Initial Value	0	0	0	0	0	0	0	0	0	0	0	0	0	0	0	0
R/W	R	R	R	R	R	R	R	R	R	R	R	R	R	R	R	R
Bit	15	14	13	12	11	10	9	8	7	6	5	4	3	2	1	0
	—	—	—	—	—	—	—	—	—	—	—	—	—	—	—	RST0_MON
Initial Value	0	0	0	0	0	0	0	0	0	0	0	0	0	0	0	0
R/W	R	R	R	R	R	R	R	R	R	R	R	R	R	R	R	R

Bit	Bit Name	Initial Value	R/W	Description
31 to 1	—	All 0	R	Reserved Whenever it is read, 0 is read. The written value will be ignored.
0	RST0_MON	0b	R	The state of the SRAM_MCPU_ARESETN reset signal is monitored. 0: Reset signal is not applied (released from the reset state). 1: Reset signal is applied (reset state).

7.2.4.107 Reset Monitor Register IAX45 (CPG_RSTMON_IAX45)

This register is used to monitor the reset signals of individual modules.

Bit	31	30	29	28	27	26	25	24	23	22	21	20	19	18	17	16
	—	—	—	—	—	—	—	—	—	—	—	—	—	—	—	—
Initial Value	0	0	0	0	0	0	0	0	0	0	0	0	0	0	0	0
R/W	R	R	R	R	R	R	R	R	R	R	R	R	R	R	R	R
Bit	15	14	13	12	11	10	9	8	7	6	5	4	3	2	1	0
	—	—	—	—	—	—	—	—	—	—	—	—	—	—	—	RST0_MON
Initial Value	0	0	0	0	0	0	0	0	0	0	0	0	0	0	0	0
R/W	R	R	R	R	R	R	R	R	R	R	R	R	R	R	R	R

Bit	Bit Name	Initial Value	R/W	Description
31 to 1	—	All 0	R	Reserved Whenever it is read, 0 is read. The written value will be ignored.
0	RST0_MON	0b	R	The state of the IAX45_RESETN reset signal is monitored. 0: Reset signal is not applied (released from the reset state). 1: Reset signal is applied (reset state).

7.2.4.108 Reset Monitor Register SYC (CPG_RSTMON_SYC)

This register is used to monitor the reset signals of individual modules.

Bit	31	30	29	28	27	26	25	24	23	22	21	20	19	18	17	16
	—	—	—	—	—	—	—	—	—	—	—	—	—	—	—	—
Initial Value	0	0	0	0	0	0	0	0	0	0	0	0	0	0	0	0
R/W	R	R	R	R	R	R	R	R	R	R	R	R	R	R	R	R
Bit	15	14	13	12	11	10	9	8	7	6	5	4	3	2	1	0
	—	—	—	—	—	—	—	—	—	—	—	—	—	—	—	RST0_MON
Initial Value	0	0	0	0	0	0	0	0	0	0	0	0	0	0	0	1
R/W	R	R	R	R	R	R	R	R	R	R	R	R	R	R	R	R

Bit	Bit Name	Initial Value	R/W	Description
31 to 1	—	All 0	R	Reserved Whenever it is read, 0 is read. The written value will be ignored.
0	RST0_MON	1b	R	The state of the SYC_RESETN reset signal is monitored. 0: Reset signal is not applied (released from the reset state). 1: Reset signal is applied (reset state).

7.2.4.109 Reset Monitor Register DMAC (CPG_RSTMON_DMACH)

This register is used to monitor the reset signals of individual modules.

Bit	31	30	29	28	27	26	25	24	23	22	21	20	19	18	17	16
	—	—	—	—	—	—	—	—	—	—	—	—	—	—	—	—
Initial Value	0	0	0	0	0	0	0	0	0	0	0	0	0	0	0	0
R/W	R	R	R	R	R	R	R	R	R	R	R	R	R	R	R	R
Bit	15	14	13	12	11	10	9	8	7	6	5	4	3	2	1	0
	—	—	—	—	—	—	—	—	—	—	—	—	—	—	RST1_MON	RST0_MON
Initial Value	0	0	0	0	0	0	0	0	0	0	0	0	0	0	1	1
R/W	R	R	R	R	R	R	R	R	R	R	R	R	R	R	R	R

Bit	Bit Name	Initial Value	R/W	Description
31 to 2	—	All 0	R	Reserved Whenever it is read, 0 is read. The written value will be ignored.
1	RST1_MON	1b	R	The state of the DMAC_RST_ASYNC reset signal is monitored. 0: Reset signal is not applied (released from the reset state). 1: Reset signal is applied (reset state).
0	RST0_MON	1b	R	The state of the DMAC_ARESETN reset signal is monitored. 0: Reset signal is not applied (released from the reset state). 1: Reset signal is applied (reset state).

7.2.4.110 Reset Monitor Register GTM (CPG_RSTMON_GTM)

This register is used to monitor the reset signals of individual modules.

Bit	31	30	29	28	27	26	25	24	23	22	21	20	19	18	17	16
	—	—	—	—	—	—	—	—	—	—	—	—	—	—	—	—
Initial Value	0	0	0	0	0	0	0	0	0	0	0	0	0	0	0	0
R/W	R	R	R	R	R	R	R	R	R	R	R	R	R	R	R	R
Bit	15	14	13	12	11	10	9	8	7	6	5	4	3	2	1	0
	—	—	—	—	—	—	—	—	—	—	—	—	—	RST2_MON	RST1_MON	RST0_MON
Initial Value	0	0	0	0	0	0	0	0	0	0	0	0	0	1	1	0
R/W	R	R	R	R	R	R	R	R	R	R	R	R	R	R	R	R

Bit	Bit Name	Initial Value	R/W	Description
31 to 3	—	All 0	R	Reserved Whenever it is read, 0 is read. The written value will be ignored.
2	RST2_MON	1b	R	The state of the OSTM2_PRESETZ reset signal is monitored. 0: Reset signal is not applied (released from the reset state). 1: Reset signal is applied (reset state).
1	RST1_MON	1b	R	The state of the OSTM1_PRESETZ reset signal is monitored. 0: Reset signal is not applied (released from the reset state). 1: Reset signal is applied (reset state).
0	RST0_MON	0b	R	The state of the OSTM0_PRESETZ reset signal is monitored. 0: Reset signal is not applied (released from the reset state). 1: Reset signal is applied (reset state).

7.2.4.111 Reset Monitor Register MTU (CPG_RSTMON_MTU)

This register is used to monitor the reset signals of individual modules.

Bit	31	30	29	28	27	26	25	24	23	22	21	20	19	18	17	16
	—	—	—	—	—	—	—	—	—	—	—	—	—	—	—	—
Initial Value	0	0	0	0	0	0	0	0	0	0	0	0	0	0	0	0
R/W	R	R	R	R	R	R	R	R	R	R	R	R	R	R	R	R
Bit	15	14	13	12	11	10	9	8	7	6	5	4	3	2	1	0
	—	—	—	—	—	—	—	—	—	—	—	—	—	—	—	RST0_MON
Initial Value	0	0	0	0	0	0	0	0	0	0	0	0	0	0	0	1
R/W	R	R	R	R	R	R	R	R	R	R	R	R	R	R	R	R

Bit	Bit Name	Initial Value	R/W	Description
31 to 1	—	All 0	R	Reserved Whenever it is read, 0 is read. The written value will be ignored.
0	RST0_MON	1b	R	The state of the MTU_X_PRESET_MTU3 reset signal is monitored. 0: Reset signal is not applied (released from the reset state). 1: Reset signal is applied (reset state).

7.2.4.112 Reset Monitor Register POE3 (CPG_RSTMON_POE3)

This register is used to monitor the reset signals of individual modules.

Bit	31	30	29	28	27	26	25	24	23	22	21	20	19	18	17	16
	—	—	—	—	—	—	—	—	—	—	—	—	—	—	—	—
Initial Value	0	0	0	0	0	0	0	0	0	0	0	0	0	0	0	0
R/W	R	R	R	R	R	R	R	R	R	R	R	R	R	R	R	R
Bit	15	14	13	12	11	10	9	8	7	6	5	4	3	2	1	0
	—	—	—	—	—	—	—	—	—	—	—	—	—	—	—	RST0_MON
Initial Value	0	0	0	0	0	0	0	0	0	0	0	0	0	0	0	1
R/W	R	R	R	R	R	R	R	R	R	R	R	R	R	R	R	R

Bit	Bit Name	Initial Value	R/W	Description
31 to 1	—	All 0	R	Reserved Whenever it is read, 0 is read. The written value will be ignored.
0	RST0_MON	1b	R	The state of the POE3_RST_M_REG reset signal is monitored. 0: Reset signal is not applied (released from the reset state). 1: Reset signal is applied (reset state).

7.2.4.113 Reset Monitor Register WDT (CPG_RSTMON_WDT)

This register is used to monitor the reset signals of individual modules.

Bit	31	30	29	28	27	26	25	24	23	22	21	20	19	18	17	16
	—	—	—	—	—	—	—	—	—	—	—	—	—	—	—	—
Initial Value	0	0	0	0	0	0	0	0	0	0	0	0	0	0	0	0
R/W	R	R	R	R	R	R	R	R	R	R	R	R	R	R	R	R
Bit	15	14	13	12	11	10	9	8	7	6	5	4	3	2	1	0
	—	—	—	—	—	—	—	—	—	—	—	—	—	—	—	RST0_MON
Initial Value	0	0	0	0	0	0	0	0	0	0	0	0	0	1	1	0
R/W	R	R	R	R	R	R	R	R	R	R	R	R	R	R	R	R

Bit	Bit Name	Initial Value	R/W	Description
31 to 4	—	All 0	R	Reserved Whenever it is read, 0 is read. The written value will be ignored.
3	—	0b	R	Reserved Whenever it is read, 0 is read. The written value will be ignored.
2	—	1b	R	Reserved When read, the initial value is read. The written value will be ignored.
1	—	1b	R	Reserved Whenever it is read, 1 is read. The written value will be ignored.
0	RST0_MON	0b	R	The state of the WDT0_PRESETN reset signal is monitored. 0: Reset signal is not applied (released from the reset state). 1: Reset signal is applied (reset state).

7.2.4.114 Reset Monitor Register DDR (CPG_RSTMON_DDR)

This register is used to monitor the reset signals of individual modules.

Bit	31	30	29	28	27	26	25	24	23	22	21	20	19	18	17	16
	—	—	—	—	—	—	—	—	—	—	—	—	—	—	—	—
Initial Value	0	0	0	0	0	0	0	0	0	0	0	0	0	0	0	0
R/W	R	R	R	R	R	R	R	R	R	R	R	R	R	R	R	R
Bit	15	14	13	12	11	10	9	8	7	6	5	4	3	2	1	0
	—	—	—	—	—	—	—	—	—	RST6_MON	RST5_MON	RST4_MON	RST3_MON	RST2_MON	RST1_MON	RST0_MON
Initial Value	0	0	0	0	0	0	0	0	0	1	1	1	1	1	1	1
R/W	R	R	R	R	R	R	R	R	R	R	R	R	R	R	R	R

Bit	Bit Name	Initial Value	R/W	Description
31 to 7	—	All 0	R	Reserved Whenever it is read, 0 is read. The written value will be ignored.
6	RST6_MON	1b	R	The state of the DDR_REG_ARESETN reset signal is monitored. 0: Reset signal is not applied (released from the reset state). 1: Reset signal is applied (reset state).
5	RST5_MON	1b	R	The state of the DDR_AXI3_ARESETN reset signal is monitored. 0: Reset signal is not applied (released from the reset state). 1: Reset signal is applied (reset state).
4	RST4_MON	1b	R	The state of the DDR_AXI2_ARESETN reset signal is monitored. 0: Reset signal is not applied (released from the reset state). 1: Reset signal is applied (reset state).
3	RST3_MON	1b	R	The state of the DDR_AXI1_ARESETN reset signal is monitored. 0: Reset signal is not applied (released from the reset state). 1: Reset signal is applied (reset state).
2	RST2_MON	1b	R	The state of the DDR_AXI0_ARESETN reset signal is monitored. 0: Reset signal is not applied (released from the reset state). 1: Reset signal is applied (reset state).
1	RST1_MON	1b	R	The state of the DDR_PRESETN reset signal is monitored. 0: Reset signal is not applied (released from the reset state). 1: Reset signal is applied (reset state).
0	RST0_MON	1b	R	The state of the DDR_RESET_N reset signal is monitored. 0: Reset signal is not applied (released from the reset state). 1: Reset signal is applied (reset state).

7.2.4.115 Reset Monitor Register SPI (CPG_RSTMON_SPI)

This register is used to monitor the reset signals of individual modules.

Bit	31	30	29	28	27	26	25	24	23	22	21	20	19	18	17	16
	—	—	—	—	—	—	—	—	—	—	—	—	—	—	—	—
Initial Value	0	0	0	0	0	0	0	0	0	0	0	0	0	0	0	0
R/W	R	R	R	R	R	R	R	R	R	R	R	R	R	R	R	R
Bit	15	14	13	12	11	10	9	8	7	6	5	4	3	2	1	0
	—	—	—	—	—	—	—	—	—	—	—	—	—	—	—	RST0_MON
Initial Value	0	0	0	0	0	0	0	0	0	0	0	0	0	0	0	1
R/W	R	R	R	R	R	R	R	R	R	R	R	R	R	R	R	R

Bit	Bit Name	Initial Value	R/W	Description
31 to 1	—	All 0	R	Reserved Whenever it is read, 0 is read. The written value will be ignored.
0	RST0_MON	1b	R	The state of the SPI_RST reset signal is monitored. 0: Reset signal is not applied (released from the reset state). 1: Reset signal is applied (reset state).

7.2.4.116 Reset Monitor Register SDHI (CPG_RSTMON_SDHI)

This register is used to monitor the reset signals of individual modules.

Bit	31	30	29	28	27	26	25	24	23	22	21	20	19	18	17	16
	—	—	—	—	—	—	—	—	—	—	—	—	—	—	—	—
Initial Value	0	0	0	0	0	0	0	0	0	0	0	0	0	0	0	0
R/W	R	R	R	R	R	R	R	R	R	R	R	R	R	R	R	R
Bit	15	14	13	12	11	10	9	8	7	6	5	4	3	2	1	0
	—	—	—	—	—	—	—	—	—	—	—	—	—	—	RST1_MON	RST0_MON
Initial Value	0	0	0	0	0	0	0	0	0	0	0	0	0	0	1	1
R/W	R	R	R	R	R	R	R	R	R	R	R	R	R	R	R	R

Bit	Bit Name	Initial Value	R/W	Description
31 to 2	—	All 0	R	Reserved Whenever it is read, 0 is read. The written value will be ignored.
1	RST1_MON	1b	R	The state of the SDHI1_IXRST reset signal is monitored. 0: Reset signal is not applied (released from the reset state). 1: Reset signal is applied (reset state).
0	RST0_MON	1b	R	The state of the SDHI0_IXRST reset signal is monitored. 0: Reset signal is not applied (released from the reset state). 1: Reset signal is applied (reset state).

7.2.4.117 Reset Monitor Register SSIF (CPG_RSTMON_SSIF)

This register is used to monitor the reset signals of individual modules.

Bit	31	30	29	28	27	26	25	24	23	22	21	20	19	18	17	16
	—	—	—	—	—	—	—	—	—	—	—	—	—	—	—	—
Initial Value	0	0	0	0	0	0	0	0	0	0	0	0	0	0	0	0
R/W	R	R	R	R	R	R	R	R	R	R	R	R	R	R	R	R
Bit	15	14	13	12	11	10	9	8	7	6	5	4	3	2	1	0
	—	—	—	—	—	—	—	—	—	—	—	—	RST3_MON	RST2_MON	RST1_MON	RST0_MON
Initial Value	0	0	0	0	0	0	0	0	0	0	0	0	1	1	1	1
R/W	R	R	R	R	R	R	R	R	R	R	R	R	R	R	R	R

Bit	Bit Name	Initial Value	R/W	Description
31 to 4	—	All 0	R	Reserved Whenever it is read, 0 is read. The written value will be ignored.
3	RST3_MON	1b	R	The state of the SSI3_RST_M2_REG reset signal is monitored. 0: Reset signal is not applied (released from the reset state). 1: Reset signal is applied (reset state).
2	RST2_MON	1b	R	The state of the SSI2_RST_M2_REG reset signal is monitored. 0: Reset signal is not applied (released from the reset state). 1: Reset signal is applied (reset state).
1	RST1_MON	1b	R	The state of the SSI1_RST_M2_REG reset signal is monitored. 0: Reset signal is not applied (released from the reset state). 1: Reset signal is applied (reset state).
0	RST0_MON	1b	R	The state of the SSI0_RST_M2_REG reset signal is monitored. 0: Reset signal is not applied (released from the reset state). 1: Reset signal is applied (reset state).

7.2.4.118 Reset Monitor Register USB (CPG_RSTMON_USB)

This register is used to monitor the reset signals of individual modules.

Bit	31	30	29	28	27	26	25	24	23	22	21	20	19	18	17	16
	—	—	—	—	—	—	—	—	—	—	—	—	—	—	—	—
Initial Value	0	0	0	0	0	0	0	0	0	0	0	0	0	0	0	0
R/W	R	R	R	R	R	R	R	R	R	R	R	R	R	R	R	R
Bit	15	14	13	12	11	10	9	8	7	6	5	4	3	2	1	0
	—	—	—	—	—	—	—	—	—	—	—	—	RST3_MON	RST2_MON	RST1_MON	RST0_MON
Initial Value	0	0	0	0	0	0	0	0	0	0	0	0	1	1	1	1
R/W	R	R	R	R	R	R	R	R	R	R	R	R	R	R	R	R

Bit	Bit Name	Initial Value	R/W	Description
31 to 4	—	All 0	R	Reserved Whenever it is read, 0 is read. The written value will be ignored.
3	RST3_MON	1b	R	The state of the USB_PRESETN reset signal is monitored. 0: Reset signal is not applied (released from the reset state). 1: Reset signal is applied (reset state).
2	RST2_MON	1b	R	The state of the USB_U2P_EXL_SYSRST reset signal is monitored. 0: Reset signal is not applied (released from the reset state). 1: Reset signal is applied (reset state).
1	RST1_MON	1b	R	The state of the USB_U2H1_HRESETN reset signal is monitored. 0: Reset signal is not applied (released from the reset state). 1: Reset signal is applied (reset state).
0	RST0_MON	1b	R	The state of the USB_U2H0_HRESETN reset signal is monitored. 0: Reset signal is not applied (released from the reset state). 1: Reset signal is applied (reset state).

7.2.4.119 Reset Monitor Register ETH (CPG_RSTMON_ETH)

This register is used to monitor the reset signals of individual modules.

Bit	31	30	29	28	27	26	25	24	23	22	21	20	19	18	17	16
	—	—	—	—	—	—	—	—	—	—	—	—	—	—	—	—
Initial Value	0	0	0	0	0	0	0	0	0	0	0	0	0	0	0	0
R/W	R	R	R	R	R	R	R	R	R	R	R	R	R	R	R	R
Bit	15	14	13	12	11	10	9	8	7	6	5	4	3	2	1	0
	—	—	—	—	—	—	—	—	—	—	—	—	—	—	RST1_MON	RST0_MON
Initial Value	0	0	0	0	0	0	0	0	0	0	0	0	0	0	1	1
R/W	R	R	R	R	R	R	R	R	R	R	R	R	R	R	R	R

Bit	Bit Name	Initial Value	R/W	Description
31 to 2	—	All 0	R	Reserved Whenever it is read, 0 is read. The written value will be ignored.
1	RST1_MON	1b	R	The state of the ETH1_RST_HW_N reset signal is monitored. 0: Reset signal is not applied (released from the reset state). 1: Reset signal is applied (reset state).
0	RST0_MON	1b	R	The state of the ETH0_RST_HW_N reset signal is monitored. 0: Reset signal is not applied (released from the reset state). 1: Reset signal is applied (reset state).

7.2.4.120 Reset Monitor Register I2C (CPG_RSTMON_I2C)

This register is used to monitor the reset signals of individual modules.

Bit	31	30	29	28	27	26	25	24	23	22	21	20	19	18	17	16
	—	—	—	—	—	—	—	—	—	—	—	—	—	—	—	—
Initial Value	0	0	0	0	0	0	0	0	0	0	0	0	0	0	0	0
R/W	R	R	R	R	R	R	R	R	R	R	R	R	R	R	R	R
Bit	15	14	13	12	11	10	9	8	7	6	5	4	3	2	1	0
	—	—	—	—	—	—	—	—	—	—	—	—	RST3_MON	RST2_MON	RST1_MON	RST0_MON
Initial Value	0	0	0	0	0	0	0	0	0	0	0	0	1	1	1	1
R/W	R	R	R	R	R	R	R	R	R	R	R	R	R	R	R	R

Bit	Bit Name	Initial Value	R/W	Description
31 to 4	—	All 0	R	Reserved Whenever it is read, 0 is read. The written value will be ignored.
3	RST3_MON	1b	R	The state of the I2C3_MRST reset signal is monitored. 0: Reset signal is not applied (released from the reset state). 1: Reset signal is applied (reset state).
2	RST2_MON	1b	R	The state of the I2C2_MRST reset signal is monitored. 0: Reset signal is not applied (released from the reset state). 1: Reset signal is applied (reset state).
1	RST1_MON	1b	R	The state of the I2C1_MRST reset signal is monitored. 0: Reset signal is not applied (released from the reset state). 1: Reset signal is applied (reset state).
0	RST0_MON	1b	R	The state of the I2C0_MRST reset signal is monitored. 0: Reset signal is not applied (released from the reset state). 1: Reset signal is applied (reset state).

7.2.4.121 Reset Monitor Register SCIF (CPG_RSTMON_SCIF)

This register is used to monitor the reset signals of individual modules.

Bit	31	30	29	28	27	26	25	24	23	22	21	20	19	18	17	16
	—	—	—	—	—	—	—	—	—	—	—	—	—	—	—	—
Initial Value	0	0	0	0	0	0	0	0	0	0	0	0	0	0	0	0
R/W	R	R	R	R	R	R	R	R	R	R	R	R	R	R	R	R
Bit	15	14	13	12	11	10	9	8	7	6	5	4	3	2	1	0
	—	—	—	—	—	—	—	—	—	—	—	RST4_MON	RST3_MON	RST2_MON	RST1_MON	RST0_MON
Initial Value	0	0	0	0	0	0	0	0	0	0	0	1	1	1	1	1
R/W	R	R	R	R	R	R	R	R	R	R	R	R	R	R	R	R

Bit	Bit Name	Initial Value	R/W	Description
31 to 5	—	All 0	R	Reserved Whenever it is read, 0 is read. The written value will be ignored.
4	RST4_MON	1b	R	The state of the SCIF4_RST_SYSTEM_N reset signal is monitored. 0: Reset signal is not applied (released from the reset state). 1: Reset signal is applied (reset state).
3	RST3_MON	1b	R	The state of the SCIF3_RST_SYSTEM_N reset signal is monitored. 0: Reset signal is not applied (released from the reset state). 1: Reset signal is applied (reset state).
2	RST2_MON	1b	R	The state of the SCIF2_RST_SYSTEM_N reset signal is monitored. 0: Reset signal is not applied (released from the reset state). 1: Reset signal is applied (reset state).
1	RST1_MON	1b	R	The state of the SCIF1_RST_SYSTEM_N reset signal is monitored. 0: Reset signal is not applied (released from the reset state). 1: Reset signal is applied (reset state).
0	RST0_MON	1b	R	The state of the SCIF0_RST_SYSTEM_N reset signal is monitored. 0: Reset signal is not applied (released from the reset state). 1: Reset signal is applied (reset state).

7.2.4.122 Reset Monitor Register SCI (CPG_RSTMON_SCI)

This register is used to monitor the reset signals of individual modules.

Bit	31	30	29	28	27	26	25	24	23	22	21	20	19	18	17	16
	—	—	—	—	—	—	—	—	—	—	—	—	—	—	—	—
Initial Value	0	0	0	0	0	0	0	0	0	0	0	0	0	0	0	0
R/W	R	R	R	R	R	R	R	R	R	R	R	R	R	R	R	R
Bit	15	14	13	12	11	10	9	8	7	6	5	4	3	2	1	0
	—	—	—	—	—	—	—	—	—	—	—	—	—	—	RST1_MON	RST0_MON
Initial Value	0	0	0	0	0	0	0	0	0	0	0	0	0	0	1	1
R/W	R	R	R	R	R	R	R	R	R	R	R	R	R	R	R	R

Bit	Bit Name	Initial Value	R/W	Description
31 to 2	—	All 0	R	Reserved Whenever it is read, 0 is read. The written value will be ignored.
1	RST1_MON	1b	R	The state of the SCI1_RST reset signal is monitored. 0: Reset signal is not applied (released from the reset state). 1: Reset signal is applied (reset state).
0	RST0_MON	1b	R	The state of the SCI0_RST reset signal is monitored. 0: Reset signal is not applied (released from the reset state). 1: Reset signal is applied (reset state).

7.2.4.123 Reset Monitor Register IRDA (CPG_RSTMON_IRDA)

This register is used to monitor the reset signals of individual modules.

Bit	31	30	29	28	27	26	25	24	23	22	21	20	19	18	17	16
	—	—	—	—	—	—	—	—	—	—	—	—	—	—	—	—
Initial Value	0	0	0	0	0	0	0	0	0	0	0	0	0	0	0	0
R/W	R	R	R	R	R	R	R	R	R	R	R	R	R	R	R	R
Bit	15	14	13	12	11	10	9	8	7	6	5	4	3	2	1	0
	—	—	—	—	—	—	—	—	—	—	—	—	—	—	—	RST0_MON
Initial Value	0	0	0	0	0	0	0	0	0	0	0	0	0	0	0	1
R/W	R	R	R	R	R	R	R	R	R	R	R	R	R	R	R	R

Bit	Bit Name	Initial Value	R/W	Description
31 to 1	—	All 0	R	Reserved Whenever it is read, 0 is read. The written value will be ignored.
0	RST0_MON	1b	R	The state of the IRDA_RST reset signal is monitored. 0: Reset signal is not applied (released from the reset state). 1: Reset signal is applied (reset state).

7.2.4.124 Reset Monitor Register RSPI (CPG_RSTMON_RSPI)

This register is used to monitor the reset signals of individual modules.

Bit	31	30	29	28	27	26	25	24	23	22	21	20	19	18	17	16
	—	—	—	—	—	—	—	—	—	—	—	—	—	—	—	—
Initial Value	0	0	0	0	0	0	0	0	0	0	0	0	0	0	0	0
R/W	R	R	R	R	R	R	R	R	R	R	R	R	R	R	R	R
Bit	15	14	13	12	11	10	9	8	7	6	5	4	3	2	1	0
	—	—	—	—	—	—	—	—	—	—	—	—	—	RST2_MON	RST1_MON	RST0_MON
Initial Value	0	0	0	0	0	0	0	0	0	0	0	0	0	1	1	1
R/W	R	R	R	R	R	R	R	R	R	R	R	R	R	R	R	R

Bit	Bit Name	Initial Value	R/W	Description
31 to 3	—	All 0	R	Reserved Whenever it is read, 0 is read. The written value will be ignored.
2	RST2_MON	1b	R	The state of the RSPI2_RST reset signal is monitored. 0: Reset signal is not applied (released from the reset state). 1: Reset signal is applied (reset state).
1	RST1_MON	1b	R	The state of the RSPI1_RST reset signal is monitored. 0: Reset signal is not applied (released from the reset state). 1: Reset signal is applied (reset state).
0	RST0_MON	1b	R	The state of the RSPI0_RST reset signal is monitored. 0: Reset signal is not applied (released from the reset state). 1: Reset signal is applied (reset state).

7.2.4.125 Reset Monitor Register CANFD (CPG_RSTMON_CANFD)

This register is used to monitor the reset signals of individual modules.

Bit	31	30	29	28	27	26	25	24	23	22	21	20	19	18	17	16
	—	—	—	—	—	—	—	—	—	—	—	—	—	—	—	—
Initial Value	0	0	0	0	0	0	0	0	0	0	0	0	0	0	0	0
R/W	R	R	R	R	R	R	R	R	R	R	R	R	R	R	R	R
Bit	15	14	13	12	11	10	9	8	7	6	5	4	3	2	1	0
	—	—	—	—	—	—	—	—	—	—	—	—	—	—	RST1_MON	RST0_MON
Initial Value	0	0	0	0	0	0	0	0	0	0	0	0	0	0	1	1
R/W	R	R	R	R	R	R	R	R	R	R	R	R	R	R	R	R

Bit	Bit Name	Initial Value	R/W	Description
31 to 2	—	All 0	R	Reserved Whenever it is read, 0 is read. The written value will be ignored.
1	RST1_MON	1b	R	The state of the CANFD_RSTC_N reset signal is monitored. 0: Reset signal is not applied (released from the reset state). 1: Reset signal is applied (reset state).
0	RST0_MON	1b	R	The state of the CANFD_RSTP_N reset signal is monitored. 0: Reset signal is not applied (released from the reset state). 1: Reset signal is applied (reset state).

7.2.4.126 Reset Monitor Register GPIO (CPG_RSTMON_GPIO)

This register is used to monitor the reset signals of individual modules.

Bit	31	30	29	28	27	26	25	24	23	22	21	20	19	18	17	16
	—	—	—	—	—	—	—	—	—	—	—	—	—	—	—	—
Initial Value	0	0	0	0	0	0	0	0	0	0	0	0	0	0	0	0
R/W	R	R	R	R	R	R	R	R	R	R	R	R	R	R	R	R
Bit	15	14	13	12	11	10	9	8	7	6	5	4	3	2	1	0
	—	—	—	—	—	—	—	—	—	—	—	—	—	RST2_MON	RST1_MON	RST0_MON
Initial Value	0	0	0	0	0	0	0	0	0	0	0	0	0	1	1	1
R/W	R	R	R	R	R	R	R	R	R	R	R	R	R	R	R	R

Bit	Bit Name	Initial Value	R/W	Description
31 to 3	—	All 0	R	Reserved Whenever it is read, 0 is read. The written value will be ignored.
2	RST2_MON	1b	R	The state of the GPIO_SPARE_RESETN reset signal is monitored. 0: Reset signal is not applied (released from the reset state). 1: Reset signal is applied (reset state).
1	RST1_MON	1b	R	The state of the GPIO_PORT_RESETN reset signal is monitored. 0: Reset signal is not applied (released from the reset state). 1: Reset signal is applied (reset state).
0	RST0_MON	1b	R	The state of the GPIO_RSTN reset signal is monitored. 0: Reset signal is not applied (released from the reset state). 1: Reset signal is applied (reset state).

7.2.4.127 Reset Monitor Register ADC (CPG_RSTMON_ADC)

This register is used to monitor the reset signals of individual modules.

Bit	31	30	29	28	27	26	25	24	23	22	21	20	19	18	17	16
	—	—	—	—	—	—	—	—	—	—	—	—	—	—	—	—
Initial Value	0	0	0	0	0	0	0	0	0	0	0	0	0	0	0	0
R/W	R	R	R	R	R	R	R	R	R	R	R	R	R	R	R	R
Bit	15	14	13	12	11	10	9	8	7	6	5	4	3	2	1	0
	—	—	—	—	—	—	—	—	—	—	—	—	—	—	RST1_MON	RST0_MON
Initial Value	0	0	0	0	0	0	0	0	0	0	0	0	0	0	1	1
R/W	R	R	R	R	R	R	R	R	R	R	R	R	R	R	R	R

Bit	Bit Name	Initial Value	R/W	Description
31 to 2	—	All 0	R	Reserved Whenever it is read, 0 is read. The written value will be ignored.
1	RST1_MON	1b	R	The state of the ADC_ADRST_N reset signal is monitored. 0: Reset signal is not applied (released from the reset state). 1: Reset signal is applied (reset state).
0	RST0_MON	1b	R	The state of the ADC_PRESETN reset signal is monitored. 0: Reset signal is not applied (released from the reset state). 1: Reset signal is applied (reset state).

7.2.4.128 Reset Monitor Register TSU (CPG_RSTMON_TSU)

This register is used to monitor the reset signals of individual modules.

Bit	31	30	29	28	27	26	25	24	23	22	21	20	19	18	17	16
	—	—	—	—	—	—	—	—	—	—	—	—	—	—	—	—
Initial Value	0	0	0	0	0	0	0	0	0	0	0	0	0	0	0	0
R/W	R	R	R	R	R	R	R	R	R	R	R	R	R	R	R	R
Bit	15	14	13	12	11	10	9	8	7	6	5	4	3	2	1	0
	—	—	—	—	—	—	—	—	—	—	—	—	—	—	—	RST0_MON
Initial Value	0	0	0	0	0	0	0	0	0	0	0	0	0	0	0	1
R/W	R	R	R	R	R	R	R	R	R	R	R	R	R	R	R	R

Bit	Bit Name	Initial Value	R/W	Description
31 to 1	—	All 0	R	Reserved Whenever it is read, 0 is read. The written value will be ignored.
0	RST0_MON	1b	R	The state of the TSU_PRESETN reset signal is monitored. 0: Reset signal is not applied (released from the reset state). 1: Reset signal is applied (reset state).

7.2.4.129 Reset Monitor Register AXI_TZCDDR (CPG_RSTMON_AXI_TZCDDR)

This register is used to monitor the reset signals of individual modules.

Bit	31	30	29	28	27	26	25	24	23	22	21	20	19	18	17	16
	—	—	—	—	—	—	—	—	—	—	—	—	—	—	—	—
Initial Value	0	0	0	0	0	0	0	0	0	0	0	0	0	0	0	0
R/W	R	R	R	R	R	R	R	R	R	R	R	R	R	R	R	R
Bit	15	14	13	12	11	10	9	8	7	6	5	4	3	2	1	0
	—	—	—	—	—	—	—	—	—	—	—	—	—	RST2_MON	RST1_MON	RST0_MON
Initial Value	0	0	0	0	0	0	0	0	0	0	0	0	0	0	0	0
R/W	R	R	R	R	R	R	R	R	R	R	R	R	R	R	R	R

Bit	Bit Name	Initial Value	R/W	Description
31 to 3	—	All 0	R	Reserved Whenever it is read, 0 is read. The written value will be ignored.
2	RST2_MON	0b	R	The state of the BUS_TZCDDR_ARESET1N reset signal is monitored. 0: Reset signal is not applied (released from the reset state). 1: Reset signal is applied (reset state).
1	RST1_MON	0b	R	The state of the BUS_TZCDDR_ARESET0N reset signal is monitored. 0: Reset signal is not applied (released from the reset state). 1: Reset signal is applied (reset state).
0	RST0_MON	0b	R	The state of the BUS_TZCDDR_PRESETN reset signal is monitored. 0: Reset signal is not applied (released from the reset state). 1: Reset signal is applied (reset state).

7.2.4.130 Reset Monitor Register AX45MP (CPG_RSTMON_AX45MP)

This register is used to monitor the reset signals of individual modules.

Bit	31	30	29	28	27	26	25	24	23	22	21	20	19	18	17	16
	—	—	—	—	—	—	—	—	—	—	—	—	—	—	—	—
Initial Value	0	0	0	0	0	0	0	0	0	0	0	0	0	0	0	0
R/W	R	R	R	R	R	R	R	R	R	R	R	R	R	R	R	R
Bit	15	14	13	12	11	10	9	8	7	6	5	4	3	2	1	0
	—	—	—	—	—	—	—	—	—	—	—	—	RST3_MON	RST2_MON	RST1_MON	RST0_MON
Initial Value	0	0	0	0	0	0	0	0	0	0	0	0	0	0	0	0
R/W	R	R	R	R	R	R	R	R	R	R	R	R	R	R	R	R

Bit	Bit Name	Initial Value	R/W	Description
31 to 4	—	All 0	R	Reserved Whenever it is read, 0 is read. The written value will be ignored.
3	RST3_MON	0b	R	The state of the AX45MP_CORE0_RESETN reset signal is monitored. 0: Reset signal is not applied (released from the reset state). 1: Reset signal is applied (reset state).
2	RST2_MON	0b	R	The state of the AX45MP_L2_RESETN reset signal is monitored. 0: Reset signal is not applied (released from the reset state). 1: Reset signal is applied (reset state).
1	RST1_MON	0b	R	The state of the AX45MP_ARESETNS reset signal is monitored. 0: Reset signal is not applied (released from the reset state). 1: Reset signal is applied (reset state).
0	RST0_MON	0b	R	The state of the AX45MP_ARESETNM reset signal is monitored. 0: Reset signal is not applied (released from the reset state). 1: Reset signal is applied (reset state).

7.2.4.131 Reset Monitor Register NCEPLDM (CPG_RSTMON_NCEPLDM)

This register is used to monitor the reset signals of individual modules.

Bit	31	30	29	28	27	26	25	24	23	22	21	20	19	18	17	16
	—	—	—	—	—	—	—	—	—	—	—	—	—	—	—	—
Initial Value	0	0	0	0	0	0	0	0	0	0	0	0	0	0	0	0
R/W	R	R	R	R	R	R	R	R	R	R	R	R	R	R	R	R
Bit	15	14	13	12	11	10	9	8	7	6	5	4	3	2	1	0
	—	—	—	—	—	—	—	—	—	—	—	—	—	—	RST1_MON	RST0_MON
Initial Value	0	0	0	0	0	0	0	0	0	0	0	0	0	0	0	0
R/W	R	R	R	R	R	R	R	R	R	R	R	R	R	R	R	R

Bit	Bit Name	Initial Value	R/W	Description
31 to 2	—	All 0	R	Reserved Whenever it is read, 0 is read. The written value will be ignored.
1	RST1_MON	0b	R	The state of the NCEPLDM_ARESETN reset signal is monitored. 0: Reset signal is not applied (released from the reset state). 1: Reset signal is applied (reset state).
0	RST0_MON	0b	R	The state of the NCEPLDM_DTM_PWR_RST_N reset signal is monitored. 0: Reset signal is not applied (released from the reset state). 1: Reset signal is applied (reset state).

7.2.4.132 Reset Monitor Register NCEPLMT (CPG_RSTMON_NCEPLMT)

This register is used to monitor the reset signals of individual modules.

Bit	31	30	29	28	27	26	25	24	23	22	21	20	19	18	17	16
	—	—	—	—	—	—	—	—	—	—	—	—	—	—	—	—
Initial Value	0	0	0	0	0	0	0	0	0	0	0	0	0	0	0	0
R/W	R	R	R	R	R	R	R	R	R	R	R	R	R	R	R	R
Bit	15	14	13	12	11	10	9	8	7	6	5	4	3	2	1	0
	—	—	—	—	—	—	—	—	—	—	—	—	—	—	RST1_MON	RST0_MON
Initial Value	0	0	0	0	0	0	0	0	0	0	0	0	0	0	0	0
R/W	R	R	R	R	R	R	R	R	R	R	R	R	R	R	R	R

Bit	Bit Name	Initial Value	R/W	Description
31 to 2	—	All 0	R	Reserved Whenever it is read, 0 is read. The written value will be ignored.
1	RST1_MON	0b	R	The state of the NCEPLMT_ARESETN reset signal is monitored. 0: Reset signal is not applied (released from the reset state). 1: Reset signal is applied (reset state).
0	RST0_MON	0b	R	The state of the NCEPLMT_POR_RSTN reset signal is monitored. 0: Reset signal is not applied (released from the reset state). 1: Reset signal is applied (reset state).

7.2.4.133 Reset Monitor Register NCEPLIC (CPG_RSTMON_NCEPLIC)

This register is used to monitor the reset signals of individual modules.

Bit	31	30	29	28	27	26	25	24	23	22	21	20	19	18	17	16
	—	—	—	—	—	—	—	—	—	—	—	—	—	—	—	—
Initial Value	0	0	0	0	0	0	0	0	0	0	0	0	0	0	0	0
R/W	R	R	R	R	R	R	R	R	R	R	R	R	R	R	R	R
Bit	15	14	13	12	11	10	9	8	7	6	5	4	3	2	1	0
	—	—	—	—	—	—	—	—	—	—	—	—	—	—	—	RST0_MON
Initial Value	0	0	0	0	0	0	0	0	0	0	0	0	0	0	0	0
R/W	R	R	R	R	R	R	R	R	R	R	R	R	R	R	R	R

Bit	Bit Name	Initial Value	R/W	Description
31 to 1	—	All 0	R	Reserved Whenever it is read, 0 is read. The written value will be ignored.
0	RST0_MON	0b	R	The state of the NCEPLIC_ARESETN reset signal is monitored. 0: Reset signal is not applied (released from the reset state). 1: Reset signal is applied (reset state).

7.2.4.134 WDT Overflow System Reset Register (CPG_WDTOVF_RST)

After the release from a system reset applied by the WDT reset circuit in response to a reset request such as a WDT overflow, this register can be used to identify the WDT channel that generated the reset request. If a system reset is not applied according to the WDTRSTSEL register setting, the WDT is not reset and the source of the reset request can be identified by checking the interrupt from the WDT and the status register.

Bit	31	30	29	28	27	26	25	24	23	22	21	20	19	18	17	16
	—	—	—	—	—	—	—	—	—	—	—	—	—	—	—	WDTOVF0_WEN
Initial Value	0	0	0	0	0	0	0	0	0	0	0	0	0	0	0	0
R/W	R	R	R	R	R	R	R	R	R	R	R	R	R	R	R	R0W1
Bit	15	14	13	12	11	10	9	8	7	6	5	4	3	2	1	0
	—	—	—	—	—	—	—	—	—	—	—	—	—	—	—	WDTOVF0
Initial Value	0	0	0	0	0	0	0	0	0	0	0	0	0	0	0	0
R/W	R	R	R	R	R	R	R	R	R	R	R	R	R	R	R	RW

Bit	Bit Name	Initial Value	R/W	Description
31 to 19	—	All 0	R	Reserved Whenever it is read, 0 is read. The written value will be ignored.
18	—	0b	R	Reserved When read, the initial value is read. When writing, be sure to write the initial value. Operation is not guaranteed if a value other than the initial value is written.
17	—	0b	R	Reserved When read, the initial value is read. When writing, be sure to write the initial value. Operation is not guaranteed if a value other than the initial value is written.
16	WDTOVF0_WEN	0b	R0W1	Flag for enabling the writing to the WDTOVF0 bit (bit 0) This bit is always read as 0. 0: Writing is disabled. 1: Writing is enabled.
15 to 3	—	All 0	R	Reserved Whenever it is read, 0 is read. The written value will be ignored.
2	—	0b	R	Reserved When read, the initial value is read. When writing, be sure to write the initial value. Operation is not guaranteed if a value other than the initial value is written.
1	—	0b	R	Reserved When read, the initial value is read. When writing, be sure to write the initial value. Operation is not guaranteed if a value other than the initial value is written.
0	WDTOVF0	0b	RW	The system reset generated WDT channel 0 for AX45MP is indicated. 0: System reset has not been generated by WDT channel 0 for AX45MP. 1: System reset has been generated by WDT channel 0 for AX45MP. <i>Note:</i> This bit is cleared by writing 1.

7.2.4.135 WDT Reset Selector Register (CPG_WDTRST_SEL)

This register is used to mask reset requests from the WDT.

Bit	31	30	29	28	27	26	25	24	23	22	21	20	19	18	17	16
	—	—	—	—	—	—	—	—	—	—	—	—	—	—	—	—
Initial Value	0	0	0	0	0	0	0	0	0	0	0	0	0	0	0	0
R/W	R	R	R	R	R	R	R	R	R	R	R	R	R	R	R	R
Bit	15	14	13	12	11	10	9	8	7	6	5	4	3	2	1	0
	—	—	—	—	—	—	—	WDTRS TSEL8	—	—	—	WDTRS TSEL4	—	—	—	WDTRS TSEL0
Initial Value	0	0	0	0	0	0	0	0	1	0	0	0	1	0	0	0
R/W	R	R	R	R	R	R	R	RW	R	R	R	RW	R	R	R	RW

Bit	Bit Name	Initial Value	R/W	Description
31 to 11	—	All 0	R	Reserved Whenever it is read, 0 is read. The written value will be ignored.
10	—	0b	R	Reserved When read, the initial value is read. When writing, be sure to write the initial value. Operation is not guaranteed if a value other than the initial value is written.
9	—	0b	R	Reserved When read, the initial value is read. When writing, be sure to write the initial value. Operation is not guaranteed if a value other than the initial value is written.
8	WDTRSTSEL 8	0b	RW	Whether to mask the reset request by WDT channel 0 is specified. 0: Cold reset of the AX45MP is masked. 1: Cold reset of the AX45MP is enabled.
7	—	1b	R	Reserved Whenever it is read, 1 is read. The written value will be ignored.
6	—	0b	R	Reserved When read, the initial value is read. When writing, be sure to write the initial value. Operation is not guaranteed if a value other than the initial value is written.
5	—	0b	R	Reserved When read, the initial value is read. When writing, be sure to write the initial value. Operation is not guaranteed if a value other than the initial value is written.
4	WDTRSTSEL 4	0b	RW	Whether to mask the assertion of WDTOVFOUT due to a request from WDT channel 0 for AX45MP is specified. 0: Assertion of WDTOVFOUT is masked. 1: Assertion of WDTOVFOUT is enabled.
3	—	1b	R	Reserved Whenever it is read, 1 is read. The written value will be ignored.
2	—	0b	R	Reserved When read, the initial value is read. When writing, be sure to write the initial value. Operation is not guaranteed if a value other than the initial value is written.
1	—	0b	R	Reserved When read, the initial value is read. When writing, be sure to write the initial value. Operation is not guaranteed if a value other than the initial value is written.
0	WDTRSTSEL 0	0b	RW	Whether to mask WDTSYSREST[0] due to a request from WDT channel 0 for AX45MP is specified. 0: System reset is masked. 1: System reset is enabled.

Note: Do not make the settings WDTRSTSEL3 = 1 and WDTRSTSEL7 = 0. If these settings are attempted, a system reset initializes the WDTRSTSEL7 bit to 1 (initial value) and WDTOVFOUT is unexpectedly asserted.

7.2.4.136 MSTOP Register ACPU (CPG_BUS_ACPU_MSTOP)

This register indicates the stop state of individual modules.

Bit	31	30	29	28	27	26	25	24	23	22	21	20	19	18	17	16
	—	—	—	—	—	—	—	—	—	—	—	—	—	—	—	MSTOP0_ON_WEN
Initial Value	0	0	0	0	0	0	0	0	0	0	0	0	0	0	0	0
R/W	R	R	R	R	R	R	R	R	R	R	R	R	R	R	R	R0W1
Bit	15	14	13	12	11	10	9	8	7	6	5	4	3	2	1	0
	—	—	—	—	—	—	—	—	—	—	—	—	—	—	—	MSTOP0_ON
Initial Value	0	0	0	0	0	0	0	0	0	0	0	0	0	0	0	0
R/W	R	R	R	R	R	R	R	R	R	R	R	R	R	R	R	RW

Bit	Bit Name	Initial Value	R/W	Description
31 to 17	—	All 0	R	Reserved Whenever it is read, 0 is read. The written value will be ignored.
16	MSTOP0_ON_WEN	0b	R0W1	Flag for enabling the writing to the MSTOP0_ON bit (bit 0) This bit is always read as 0. 0: Writing is disabled. 1: Writing is enabled.
15 to 1	—	All 0	R	Reserved Whenever it is read, 0 is read. The written value will be ignored.
0	MSTOP0_ON	0b	RW	The state of BUS_ACPU_MSTOP_MXSRAM_A operation is indicated. 0: Normal operation 1: Module stop state (MSTP)

7.2.4.137 MSTOP Register MCPU1 (CPG_BUS_MCPU1_MSTOP)

This register indicates the stop state of individual modules.

Bit	31	30	29	28	27	26	25	24	23	22	21	20	19	18	17	16
	MSTOP15_ON_WEN	MSTOP14_ON_WEN	MSTOP13_ON_WEN	MSTOP12_ON_WEN	MSTOP11_ON_WEN	MSTOP10_ON_WEN	MSTOP9_ON_WEN	—	—	—	—	—	MSTOP3_ON_WEN	MSTOP2_ON_WEN	MSTOP1_ON_WEN	MSTOP0_ON_WEN
Initial Value	0	0	0	0	0	0	0	0	0	0	0	0	0	0	0	0
R/W	R0W1	R0W1	R0W1	R0W1	R0W1	R0W1	R0W1	R	R	R	R	R	R0W1	R0W1	R0W1	R0W1

Bit	15	14	13	12	11	10	9	8	7	6	5	4	3	2	1	0
	MSTOP15_ON	MSTOP14_ON	MSTOP13_ON	MSTOP12_ON	MSTOP11_ON	MSTOP10_ON	MSTOP9_ON	—	—	—	—	—	—	MSTOP2_ON	MSTOP1_ON	MSTOP0_ON
Initial Value	0	0	0	0	0	0	0	0	0	0	0	0	0	0	0	0
R/W	RW	RW	RW	RW	RW	RW	RW	R	R	R	R	R	R	RW	RW	RW

Bit	Bit Name	Initial Value	R/W	Description
31	MSTOP15_ON_WEN	0b	R0W1	Flag for enabling the writing to the MSTOP15_ON bit (bit 15) This bit is always read as 0. 0: Writing is disabled. 1: Writing is enabled.
30	MSTOP14_ON_WEN	0b	R0W1	Flag for enabling the writing to the MSTOP14_ON bit (bit 14) This bit is always read as 0. 0: Writing is disabled. 1: Writing is enabled.
29	MSTOP13_ON_WEN	0b	R0W1	Flag for enabling the writing to the MSTOP13_ON bit (bit 13) This bit is always read as 0. 0: Writing is disabled. 1: Writing is enabled.
28	MSTOP12_ON_WEN	0b	R0W1	Flag for enabling the writing to the MSTOP12_ON bit (bit 12) This bit is always read as 0. 0: Writing is disabled. 1: Writing is enabled.
27	MSTOP11_ON_WEN	0b	R0W1	Flag for enabling the writing to the MSTOP11_ON bit (bit 11) This bit is always read as 0. 0: Writing is disabled. 1: Writing is enabled.
26	MSTOP10_ON_WEN	0b	R0W1	Flag for enabling the writing to the MSTOP10_ON bit (bit 10) This bit is always read as 0. 0: Writing is disabled. 1: Writing is enabled.
25	MSTOP9_ON_WEN	0b	R0W1	Flag for enabling the writing to the MSTOP9_ON bit (bit 9) This bit is always read as 0. 0: Writing is disabled. 1: Writing is enabled.
24 to 20	—	All 0	R	Reserved When read, the initial value is read. When writing, be sure to write the initial value. Operation is not guaranteed if a value other than the initial value is written.
19	MSTOP3_ON_WEN	0b	R0W1	Flag for enabling the writing to the MSTOP3_ON bit (bit 3) This bit is always read as 0. 0: Writing is disabled. 1: Writing is enabled.

Bit	Bit Name	Initial Value	R/W	Description
18	MSTOP2_ON_WEN	0b	R0W1	Flag for enabling the writing to the MSTOP2_ON bit (bit 2) This bit is always read as 0. 0: Writing is disabled. 1: Writing is enabled.
17	MSTOP1_ON_WEN	0b	R0W1	Flag for enabling the writing to the MSTOP1_ON bit (bit 1) This bit is always read as 0. 0: Writing is disabled. 1: Writing is enabled.
16	MSTOP0_ON_WEN	0b	R0W1	Flag for enabling the writing to the MSTOP0_ON bit (bit 0) This bit is always read as 0. 0: Writing is disabled. 1: Writing is enabled.
15	MSTOP15_ON	0b	RW	The state of BUS_MCPU_MSTOP13_MHRSPI_1 operation is indicated. 0: Normal operation 1: Module stop state (MSTP)
14	MSTOP14_ON	0b	RW	The state of BUS_MCPU_MSTOP12_MHRSPI_0 operation is indicated. 0: Normal operation 1: Module stop state (MSTP)
13	MSTOP13_ON	0b	RW	The state of BUS_MCPU_MSTOP11_MHSSIF_3 operation is indicated. 0: Normal operation 1: Module stop state (MSTP)
12	MSTOP12_ON	0b	RW	The state of BUS_MCPU_MSTOP10_MHSSIF_2 operation is indicated. 0: Normal operation 1: Module stop state (MSTP)
11	MSTOP11_ON	0b	RW	The state of BUS_MCPU_MSTOP9_MHSSIF_1 operation is indicated. 0: Normal operation 1: Module stop state (MSTP)
10	MSTOP10_ON	0b	RW	The state of BUS_MCPU_MSTOP8_MHSSIF_0 operation is indicated. 0: Normal operation 1: Module stop state (MSTP)
9	MSTOP9_ON	0b	RW	The state of BUS_MCPU_MSTOP7_MHPOE3 operation is indicated. 0: Normal operation 1: Module stop state (MSTP)
8 to 3	—	0b	R	Reserved When read, the initial value is read. When writing, be sure to write the initial value. Operation is not guaranteed if a value other than the initial value is written.
2	MSTOP2_ON	0b	RW	The state of BUS_MCPU_MSTOP0_MHMTU3A operation is indicated. 0: Normal operation 1: Module stop state (MSTP)
1	MSTOP1_ON	0b	RW	The state of BUS_MCPU_MSTOP_MHSPI operation is indicated. 0: Normal operation 1: Module stop state (MSTP)
0	MSTOP0_ON	0b	RW	The state of BUS_MCPU_MSTOP_MXSRAM_M operation is indicated. 0: Normal operation 1: Module stop state (MSTP)

7.2.4.138 MSTOP Register MCPU2 (CPG_BUS_MCPU2_MSTOP)

This register indicates the stop state of individual modules.

Bit	31	30	29	28	27	26	25	24	23	22	21	20	19	18	17	16
	MSTOP15_ON_WEN	MSTOP14_ON_WEN	MSTOP13_ON_WEN	MSTOP12_ON_WEN	MSTOP11_ON_WEN	MSTOP10_ON_WEN	MSTOP9_ON_WEN	MSTOP8_ON_WEN	MSTOP7_ON_WEN	MSTOP6_ON_WEN	MSTOP5_ON_WEN	MSTOP4_ON_WEN	MSTOP3_ON_WEN	MSTOP2_ON_WEN	MSTOP1_ON_WEN	MSTOP0_ON_WEN
Initial Value	0	0	0	0	0	0	0	0	0	0	0	0	0	0	0	0
R/W	R0W1	R0W1	R0W1	R0W1	R0W1	R0W1	R0W1	R0W1	R0W1	R0W1	R0W1	R0W1	R0W1	R0W1	R0W1	R0W1

Bit	15	14	13	12	11	10	9	8	7	6	5	4	3	2	1	0
	MSTOP15_ON	MSTOP14_ON	MSTOP13_ON	MSTOP12_ON	MSTOP11_ON	MSTOP10_ON	MSTOP9_ON	MSTOP8_ON	MSTOP7_ON	MSTOP6_ON	MSTOP5_ON	MSTOP4_ON	MSTOP3_ON	MSTOP2_ON	MSTOP1_ON	MSTOP0_ON
Initial Value	0	0	0	0	0	0	0	0	0	0	0	0	0	0	0	0
R/W	RW	RW	RW	RW	RW	RW	RW	RW	RW	RW	RW	RW	RW	RW	RW	RW

Bit	Bit Name	Initial Value	R/W	Description
31	MSTOP15_ON_WEN	0b	R0W1	Flag for enabling the writing to the MSTOP15_ON bit (bit 15) This bit is always read as 0. 0: Writing is disabled. 1: Writing is enabled.
30	MSTOP14_ON_WEN	0b	R0W1	Flag for enabling the writing to the MSTOP14_ON bit (bit 14) This bit is always read as 0. 0: Writing is disabled. 1: Writing is enabled.
29	MSTOP13_ON_WEN	0b	R0W1	Flag for enabling the writing to the MSTOP13_ON bit (bit 13) This bit is always read as 0. 0: Writing is disabled. 1: Writing is enabled.
28	MSTOP12_ON_WEN	0b	R0W1	Flag for enabling the writing to the MSTOP12_ON bit (bit 12) This bit is always read as 0. 0: Writing is disabled. 1: Writing is enabled.
27	MSTOP11_ON_WEN	0b	R0W1	Flag for enabling the writing to the MSTOP11_ON bit (bit 11) This bit is always read as 0. 0: Writing is disabled. 1: Writing is enabled.
26	MSTOP10_ON_WEN	0b	R0W1	Flag for enabling the writing to the MSTOP10_ON bit (bit 10) This bit is always read as 0. 0: Writing is disabled. 1: Writing is enabled.
25	MSTOP9_ON_WEN	0b	R0W1	Flag for enabling the writing to the MSTOP9_ON bit (bit 9) This bit is always read as 0. 0: Writing is disabled. 1: Writing is enabled.
24	MSTOP8_ON_WEN	0b	R0W1	Flag for enabling the writing to the MSTOP8_ON bit (bit 8) This bit is always read as 0. 0: Writing is disabled. 1: Writing is enabled.
23	MSTOP7_ON_WEN	0b	R0W1	Flag for enabling the writing to the MSTOP7_ON bit (bit 7) This bit is always read as 0. 0: Writing is disabled. 1: Writing is enabled.

Bit	Bit Name	Initial Value	R/W	Description
22	MSTOP6_ON_WEN	0b	R0W1	Flag for enabling the writing to the MSTOP6_ON bit (bit 6) This bit is always read as 0. 0: Writing is disabled. 1: Writing is enabled.
21	MSTOP5_ON_WEN	0b	R0W1	Flag for enabling the writing to the MSTOP5_ON bit (bit 5) This bit is always read as 0. 0: Writing is disabled. 1: Writing is enabled.
20	MSTOP4_ON_WEN	0b	R0W1	Flag for enabling the writing to the MSTOP4_ON bit (bit 4) This bit is always read as 0. 0: Writing is disabled. 1: Writing is enabled.
19	MSTOP3_ON_WEN	0b	R0W1	Flag for enabling the writing to the MSTOP3_ON bit (bit 3) This bit is always read as 0. 0: Writing is disabled. 1: Writing is enabled.
18	MSTOP2_ON_WEN	0b	R0W1	Flag for enabling the writing to the MSTOP2_ON bit (bit 2) This bit is always read as 0. 0: Writing is disabled. 1: Writing is enabled.
17	MSTOP1_ON_WEN	0b	R0W1	Flag for enabling the writing to the MSTOP1_ON bit (bit 1) This bit is always read as 0. 0: Writing is disabled. 1: Writing is enabled.
16	MSTOP0_ON_WEN	0b	R0W1	Flag for enabling the writing to the MSTOP0_ON bit (bit 0) This bit is always read as 0. 0: Writing is disabled. 1: Writing is enabled.
15	MSTOP15_ON	0b	RW	The state of BUS_MCPU_MSTOP29_MPTSU operation is indicated. 0: Normal operation 1: Module stop state (MSTP)
14	MSTOP14_ON	0b	RW	The state of BUS_MCPU_MSTOP28_MPADC operation is indicated. 0: Normal operation 1: Module stop state (MSTP)
13	MSTOP13_ON	0b	RW	The state of BUS_MCPU_MSTOP27_MPI2C_3 operation is indicated. 0: Normal operation 1: Module stop state (MSTP)
12	MSTOP12_ON	0b	RW	The state of BUS_MCPU_MSTOP26_MPI2C_2 operation is indicated. 0: Normal operation 1: Module stop state (MSTP)
11	MSTOP11_ON	0b	RW	The state of BUS_MCPU_MSTOP25_MPI2C_1 operation is indicated. 0: Normal operation 1: Module stop state (MSTP)
10	MSTOP10_ON	0b	RW	The state of BUS_MCPU_MSTOP24_MPI2C_0 operation is indicated. 0: Normal operation 1: Module stop state (MSTP)
9	MSTOP9_ON	0b	RW	The state of BUS_MCPU_MSTOP23_MPCANFD operation is indicated. 0: Normal operation 1: Module stop state (MSTP)
8	MSTOP8_ON	0b	RW	The state of BUS_MCPU_MSTOP22_MHSCI_1 operation is indicated. 0: Normal operation 1: Module stop state (MSTP)

Bit	Bit Name	Initial Value	R/W	Description
7	MSTOP7_ON	0b	RW	The state of BUS_MCPU_MSTOP21_MHSCI_0 operation is indicated. 0: Normal operation 1: Module stop state (MSTP)
6	MSTOP6_ON	0b	RW	The state of BUS_MCPU_MSTOP20_MHIRDA operation is indicated. 0: Normal operation 1: Module stop state (MSTP)
5	MSTOP5_ON	0b	RW	The state of BUS_MCPU_MSTOP19_MHSCIF_4 operation is indicated. 0: Normal operation 1: Module stop state (MSTP)
4	MSTOP4_ON	0b	RW	The state of BUS_MCPU_MSTOP18_MHSCIF_3 operation is indicated. 0: Normal operation 1: Module stop state (MSTP)
3	MSTOP3_ON	0b	RW	The state of BUS_MCPU_MSTOP17_MHSCIF_2 operation is indicated. 0: Normal operation 1: Module stop state (MSTP)
2	MSTOP2_ON	0b	RW	The state of BUS_MCPU_MSTOP16_MHSCIF_1 operation is indicated. 0: Normal operation 1: Module stop state (MSTP)
1	MSTOP1_ON	0b	RW	The state of BUS_MCPU_MSTOP15_MHSCIF_0 operation is indicated. 0: Normal operation 1: Module stop state (MSTP)
0	MSTOP0_ON	0b	RW	The state of BUS_MCPU_MSTOP14_MHRSPI_2 operation is indicated. 0: Normal operation 1: Module stop state (MSTP)

7.2.4.139 MSTOP Register PERI_COM (CPG_BUS_PERI_COM_MSTOP)

This register indicates the stop state of individual modules.

Bit	31	30	29	28	27	26	25	24	23	22	21	20	19	18	17	16
	—	—	—	—	—	—	—	MSTOP8_ON_WEN	MSTOP7_ON_WEN	MSTOP6_ON_WEN	MSTOP5_ON_WEN	MSTOP4_ON_WEN	MSTOP3_ON_WEN	MSTOP2_ON_WEN	MSTOP1_ON_WEN	MSTOP0_ON_WEN
Initial Value	0	0	0	0	0	0	0	0	0	0	0	0	0	0	0	0
R/W	R	R	R	R	R	R	R	R0W1	R0W1	R0W1	R0W1	R0W1	R0W1	R0W1	R0W1	R0W1

Bit	15	14	13	12	11	10	9	8	7	6	5	4	3	2	1	0
	—	—	—	—	—	—	—	MSTOP8_ON	MSTOP7_ON	MSTOP6_ON	MSTOP5_ON	MSTOP4_ON	MSTOP3_ON	MSTOP2_ON	MSTOP1_ON	MSTOP0_ON
Initial Value	0	0	0	0	0	0	0	0	0	0	0	0	0	0	0	0
R/W	R	R	R	R	R	R	R	RW	RW	RW	RW	RW	RW	RW	RW	RW

Bit	Bit Name	Initial Value	R/W	Description
31 to 25	—	All 0	R	Reserved Whenever it is read, 0 is read. The written value will be ignored.
24	MSTOP8_ON_WEN	0b	R0W1	Flag for enabling the writing to the MSTOP8_ON bit (bit 8) This bit is always read as 0. 0: Writing is disabled. 1: Writing is enabled.
23	MSTOP7_ON_WEN	0b	R0W1	Flag for enabling the writing to the MSTOP7_ON bit (bit 7) This bit is always read as 0. 0: Writing is disabled. 1: Writing is enabled.
22	MSTOP6_ON_WEN	0b	R0W1	Flag for enabling the writing to the MSTOP6_ON bit (bit 6) This bit is always read as 0. 0: Writing is disabled. 1: Writing is enabled.
21	MSTOP5_ON_WEN	0b	R0W1	Flag for enabling the writing to the MSTOP5_ON bit (bit 5) This bit is always read as 0. 0: Writing is disabled. 1: Writing is enabled.
20	MSTOP4_ON_WEN	0b	R0W1	Flag for enabling the writing to the MSTOP4_ON bit (bit 4) This bit is always read as 0. 0: Writing is disabled. 1: Writing is enabled.
19	MSTOP3_ON_WEN	0b	R0W1	Flag for enabling the writing to the MSTOP3_ON bit (bit 3) This bit is always read as 0. 0: Writing is disabled. 1: Writing is enabled.
18	MSTOP2_ON_WEN	0b	R0W1	Flag for enabling the writing to the MSTOP2_ON bit (bit 2) This bit is always read as 0. 0: Writing is disabled. 1: Writing is enabled.
17	MSTOP1_ON_WEN	0b	R0W1	Flag for enabling the writing to the MSTOP1_ON bit (bit 1) This bit is always read as 0. 0: Writing is disabled. 1: Writing is enabled.

Bit	Bit Name	Initial Value	R/W	Description
16	MSTOP0_ON_WEN	0b	R0W1	Flag for enabling the writing to the MSTOP0_ON bit (bit 0) This bit is always read as 0. 0: Writing is disabled. 1: Writing is enabled.
15 to 9	—	All 0	R	Reserved Whenever it is read, 0 is read. The written value will be ignored.
8	MSTOP8_ON	0b	RW	The state of BUS_PERI_COM_MSTOP8_MXCOM operation is indicated. 0: Normal operation 1: Module stop state (MSTP)
7	MSTOP7_ON	0b	RW	The state of BUS_PERI_COM_MSTOP7_MHUSB2_1 operation is indicated. 0: Normal operation 1: Module stop state (MSTP)
6	MSTOP6_ON	0b	RW	The state of BUS_PERI_COM_MSTOP6_MHUSB2_0_F operation is indicated. 0: Normal operation 1: Module stop state (MSTP)
5	MSTOP5_ON	0b	RW	The state of BUS_PERI_COM_MSTOP5_MHUSB2_0_H operation is indicated. 0: Normal operation 1: Module stop state (MSTP)
4	MSTOP4_ON	0b	RW	The state of BUS_PERI_COM_MSTOP4_MPUSBT operation is indicated. 0: Normal operation 1: Module stop state (MSTP)
3	MSTOP3_ON	0b	RW	The state of BUS_PERI_COM_MSTOP3_MPGIGE_1 operation is indicated. 0: Normal operation 1: Module stop state (MSTP)
2	MSTOP2_ON	0b	RW	The state of BUS_PERI_COM_MSTOP2_MPGIGE_0 operation is indicated. 0: Normal operation 1: Module stop state (MSTP)
1	MSTOP1_ON	0b	RW	The state of BUS_PERI_COM_MSTOP1_MXSDHI_1 operation is indicated. 0: Normal operation 1: Module stop state (MSTP)
0	MSTOP0_ON	0b	RW	The state of BUS_PERI_COM_MSTOP0_MXSDHI_0 operation is indicated. 0: Normal operation 1: Module stop state (MSTP)

7.2.4.140 MSTOP Register PERI_CPU (CPG_BUS_PERI_CPU_MSTOP)

This register indicates the stop state of individual modules.

Bit	31	30	29	28	27	26	25	24	23	22	21	20	19	18	17	16
	MSTOP15_ON_WEN	—	MSTOP13_ON_WEN	MSTOP12_ON_WEN	MSTOP11_ON_WEN	—	—	MSTOP8_ON_WEN	MSTOP7_ON_WEN	MSTOP6_ON_WEN	—	MSTOP4_ON_WEN	MSTOP3_ON_WEN	—	MSTOP1_ON_WEN	MSTOP0_ON_WEN
Initial Value	0	0	0	0	0	0	0	0	0	0	0	0	0	0	0	0
R/W	R0W1	R	R0W1	R0W1	R0W1	R	R	R0W1	R0W1	R0W1	R	R0W1	R0W1	R	R0W1	R0W1

Bit	15	14	13	12	11	10	9	8	7	6	5	4	3	2	1	0
	MSTOP15_ON	—	MSTOP13_ON	MSTOP12_ON	MSTOP11_ON	—	—	MSTOP8_ON	MSTOP7_ON	MSTOP6_ON	—	MSTOP4_ON	MSTOP3_ON	—	MSTOP1_ON	MSTOP0_ON
Initial Value	0	0	0	0	0	0	0	0	0	0	0	0	0	0	0	0
R/W	RW	R	RW	RW	RW	R	R	RW	RW	RW	R	RW	RW	R	RW	RW

Bit	Bit Name	Initial Value	R/W	Description
31	MSTOP15_ON_WEN	0b	R0W1	Flag for enabling the writing to the MSTOP15_ON bit (bit 15) This bit is always read as 0. 0: Writing is disabled. 1: Writing is enabled.
30	—	0b	R	Reserved When read, the initial value is read. When writing, be sure to write the initial value. Operation is not guaranteed if a value other than the initial value is written.
29	MSTOP13_ON_WEN	0b	R0W1	Flag for enabling the writing to the MSTOP13_ON bit (bit 13) This bit is always read as 0. 0: Writing is disabled. 1: Writing is enabled.
28	MSTOP12_ON_WEN	0b	R0W1	Flag for enabling the writing to the MSTOP12_ON bit (bit 12) This bit is always read as 0. 0: Writing is disabled. 1: Writing is enabled.
27	MSTOP11_ON_WEN	0b	R0W1	Flag for enabling the writing to the MSTOP11_ON bit (bit 11) This bit is always read as 0. 0: Writing is disabled. 1: Writing is enabled.
26, 25	—	00b	R	Reserved Whenever it is read, 0 is read. The written value will be ignored.
24	MSTOP8_ON_WEN	0b	R0W1	Flag for enabling the writing to the MSTOP8_ON bit (bit 8) This bit is always read as 0. 0: Writing is disabled. 1: Writing is enabled.
23	MSTOP7_ON_WEN	0b	R0W1	Flag for enabling the writing to the MSTOP7_ON bit (bit 7) This bit is always read as 0. 0: Writing is disabled. 1: Writing is enabled.
22	MSTOP6_ON_WEN	0b	R0W1	Flag for enabling the writing to the MSTOP6_ON bit (bit 6) This bit is always read as 0. 0: Writing is disabled. 1: Writing is enabled.
21	—	0b	R	Reserved Whenever it is read, 0 is read. The written value will be ignored.

Bit	Bit Name	Initial Value	R/W	Description
20	MSTOP4_ON_WEN	0b	R0W1	Flag for enabling the writing to the MSTOP4_ON bit (bit 4) This bit is always read as 0. 0: Writing is disabled. 1: Writing is enabled.
19	MSTOP3_ON_WEN	0b	R0W1	Flag for enabling the writing to the MSTOP3_ON bit (bit 3) This bit is always read as 0. 0: Writing is disabled. 1: Writing is enabled.
18	—	0b	R	Reserved Whenever it is read, 0 is read. The written value will be ignored.
17	MSTOP1_ON_WEN	0b	R0W1	Flag for enabling the writing to the MSTOP1_ON bit (bit 1) This bit is always read as 0. 0: Writing is disabled. 1: Writing is enabled.
16	MSTOP0_ON_WEN	0b	R0W1	Flag for enabling the writing to the MSTOP0_ON bit (bit 0) This bit is always read as 0. 0: Writing is disabled. 1: Writing is enabled.
15	MSTOP15_ON	0b	RW	The state of BUS_PERI_CPU_MSTOP15_MXREG0 operation is indicated. 0: Normal operation 1: Module stop state (MSTP)
14	—	0b	R	Reserved When read, the initial value is read. When writing, be sure to write the initial value. Operation is not guaranteed if a value other than the initial value is written.
13	MSTOP13_ON	0b	RW	The state of BUS_PERI_CPU_MSTOP13_MPIAX45 operation is indicated. 0: Normal operation 1: Module stop state (MSTP)
12	MSTOP12_ON	0b	RW	The state of BUS_PERI_CPU_MSTOP12_MPSRAM_M operation is indicated. 0: Normal operation 1: Module stop state (MSTP)
11	MSTOP11_ON	0b	RW	The state of BUS_PERI_CPU_MSTOP11_MPSRAM_A operation is indicated. 0: Normal operation 1: Module stop state (MSTP)
10, 9	—	00b	R	Reserved Whenever it is read, 0 is read. The written value will be ignored.
8	MSTOP8_ON	0b	RW	The state of BUS_PERI_CPU_MSTOP8_MPTZC_1 operation is indicated. 0: Normal operation 1: Module stop state (MSTP)
7	MSTOP7_ON	0b	RW	The state of BUS_PERI_CPU_MSTOP7_MPTZC_0 operation is indicated. 0: Normal operation 1: Module stop state (MSTP)
6	MSTOP6_ON	0b	RW	The state of BUS_PERI_CPU_MSTOP6_MHGPI0 operation is indicated. 0: Normal operation 1: Module stop state (MSTP)
5	—	0b	R	Reserved Whenever it is read, 0 is read. The written value will be ignored.
4	MSTOP4_ON	0b	RW	The state of BUS_PERI_CPU_MSTOP4_MPCPG operation is indicated. 0: Normal operation 1: Module stop state (MSTP)
3	MSTOP3_ON	0b	RW	The state of BUS_PERI_CPU_MSTOP3_MPSPYC operation is indicated. 0: Normal operation 1: Module stop state (MSTP)

Bit	Bit Name	Initial Value	R/W	Description
2	—	0b	R	Reserved Whenever it is read, 0 is read. The written value will be ignored.
1	MSTOP1_ON	0b	RW	The state of BUS_PERI_CPU_MSTOP1_MXACPU operation is indicated. 0: Normal operation 1: Module stop state (MSTP)
0	MSTOP0_ON	0b	RW	The state of BUS_PERI_CPU_MSTOP0_MXMCPU operation is indicated. 0: Normal operation 1: Module stop state (MSTP)

7.2.4.141 MSTOP Register PERI_DDR (CPG_BUS_PERI_DDR_MSTOP)

This register indicates the stop state of individual modules.

Bit	31	30	29	28	27	26	25	24	23	22	21	20	19	18	17	16
	—	—	—	—	—	—	—	—	—	—	—	—	—	—	MSTOP1_ON_WEN	MSTOP0_ON_WEN
Initial Value	0	0	0	0	0	0	0	0	0	0	0	0	0	0	0	0
R/W	R	R	R	R	R	R	R	R	R	R	R	R	R	R	R0W1	R0W1
Bit	15	14	13	12	11	10	9	8	7	6	5	4	3	2	1	0
	—	—	—	—	—	—	—	—	—	—	—	—	—	—	MSTOP1_ON	MSTOP0_ON
Initial Value	0	0	0	0	0	0	0	0	0	0	0	0	0	0	0	0
R/W	R	R	R	R	R	R	R	R	R	R	R	R	R	R	RW	RW

Bit	Bit Name	Initial Value	R/W	Description
31 to 18	—	All 0	R	Reserved Whenever it is read, 0 is read. The written value will be ignored.
17	MSTOP1_ON_WEN	0b	R0W1	Flag for enabling the writing to the MSTOP1_ON bit (bit 1) This bit is always read as 0. 0: Writing is disabled. 1: Writing is enabled.
16	MSTOP0_ON_WEN	0b	R0W1	Flag for enabling the writing to the MSTOP0_ON bit (bit 0) This bit is always read as 0. 0: Writing is disabled. 1: Writing is enabled.
15 to 2	—	All 0	R	Reserved Whenever it is read, 0 is read. The written value will be ignored.
1	MSTOP1_ON	0b	RW	The state of BUS_PERI_DDR_MSTOP1_MXMEMC_REG operation is indicated. 0: Normal operation 1: Module stop state (MSTP)
0	MSTOP0_ON	0b	RW	The state of BUS_PERI_DDR_MSTOP0_MPPHY operation is indicated. 0: Normal operation 1: Module stop state (MSTP)

7.2.4.142 MSTOP Register REG0 (CPG_BUS_REG0_MSTOP)

This register indicates the stop state of individual modules.

Bit	31	30	29	28	27	26	25	24	23	22	21	20	19	18	17	16
	—	—	—	—	—	—	—	—	—	MSTOP6_ON_WEN	MSTOP5_ON_WEN	MSTOP4_ON_WEN	—	MSTOP2_ON_WEN	—	—
Initial Value	0	0	0	0	0	0	0	0	0	0	0	0	0	0	0	0
R/W	R	R	R	R	R	R	R	R	R	R0W1	R0W1	R0W1	R	R0W1	R	R
Bit	15	14	13	12	11	10	9	8	7	6	5	4	3	2	1	0
	—	—	—	—	—	—	—	—	—	MSTOP6_ON	MSTOP5_ON	MSTOP4_ON	—	MSTOP2_ON	—	—
Initial Value	0	0	0	0	0	0	0	0	0	0	0	0	0	0	0	0
R/W	R	R	R	R	R	R	R	R	R	RW	RW	RW	R	RW	R	R

Bit	Bit Name	Initial Value	R/W	Description
31 to 23	—	All 0	R	Reserved Whenever it is read, 0 is read. The written value will be ignored.
22	MSTOP6_ON_WEN	0b	R0W1	Flag for enabling the writing to the MSTOP6_ON bit (bit 6) This bit is always read as 0. 0: Writing is disabled. 1: Writing is enabled.
21	MSTOP5_ON_WEN	0b	R0W1	Flag for enabling the writing to the MSTOP5_ON bit (bit 5) This bit is always read as 0. 0: Writing is disabled. 1: Writing is enabled.
20	MSTOP4_ON_WEN	0b	R0W1	Flag for enabling the writing to the MSTOP4_ON bit (bit 4) This bit is always read as 0. 0: Writing is disabled. 1: Writing is enabled.
19	—	0b	R	Reserved When read, the initial value is read. When writing, be sure to write the initial value. Operation is not guaranteed if a value other than the initial value is written.
18	MSTOP2_ON_WEN	0b	R0W1	Flag for enabling the writing to the MSTOP2_ON bit (bit 2) This bit is always read as 0. 0: Writing is disabled. 1: Writing is enabled.
17	—	0b	R	Reserved When read, the initial value is read. When writing, be sure to write the initial value. Operation is not guaranteed if a value other than the initial value is written.
16	—	0b	R	Reserved When read, the initial value is read. When writing, be sure to write the initial value. Operation is not guaranteed if a value other than the initial value is written.
15 to 7	—	All 0	R	Reserved Whenever it is read, 0 is read. The written value will be ignored.
6	MSTOP6_ON	0b	RW	The state of BUS_REG0_MSTOP6_MPOSTM_2 operation is indicated. 0: Normal operation 1: Module stop state (MSTP)
5	MSTOP5_ON	0b	RW	The state of BUS_REG0_MSTOP5_MPOSTM_1 operation is indicated. 0: Normal operation 1: Module stop state (MSTP)

Bit	Bit Name	Initial Value	R/W	Description
4	MSTOP4_ON	0b	RW	The state of BUS_REG0_MSTOP4_MPOSTM_0 operation is indicated. 0: Normal operation 1: Module stop state (MSTP)
3	—	0b	R	Reserved When read, the initial value is read. When writing, be sure to write the initial value. Operation is not guaranteed if a value other than the initial value is written.
2	MSTOP2_ON	0b	RW	The state of BUS_REG0_MSTOP2_MPWDT_0 operation is indicated. 0: Normal operation 1: Module stop state (MSTP)
1	—	0b	R	Reserved When read, the initial value is read. When writing, be sure to write the initial value. Operation is not guaranteed if a value other than the initial value is written.
0	—	0b	R	Reserved When read, the initial value is read. When writing, be sure to write the initial value. Operation is not guaranteed if a value other than the initial value is written.

7.2.4.143 MSTOP Register REG1 (CPG_BUS_REG1_MSTOP)

This register indicates the stop state of individual modules.

Bit	31	30	29	28	27	26	25	24	23	22	21	20	19	18	17	16
	—	—	—	—	—	—	—	—	MSTOP7_ON_WEN	MSTOP6_ON_WEN	MSTOP5_ON_WEN	—	MSTOP3_ON_WEN	MSTOP2_ON_WEN	MSTOP1_ON_WEN	MSTOP0_ON_WEN
Initial Value	0	0	0	0	0	0	0	0	0	0	0	0	0	0	0	0
R/W	R	R	R	R	R	R	R	R	R0W1	R0W1	R0W1	R	R0W1	R0W1	R0W1	R0W1

Bit	15	14	13	12	11	10	9	8	7	6	5	4	3	2	1	0
	—	—	—	—	—	—	—	—	MSTOP7_ON	MSTOP6_ON	MSTOP5_ON	—	MSTOP3_ON	MSTOP2_ON	MSTOP1_ON	MSTOP0_ON
Initial Value	0	0	0	0	0	0	0	0	0	0	0	0	0	0	0	0
R/W	R	R	R	R	R	R	R	R	RW	RW	RW	R	RW	RW	RW	RW

Bit	Bit Name	Initial Value	R/W	Description
31 to 24	—	All 0	R	Reserved Whenever it is read, 0 is read. The written value will be ignored.
23	MSTOP7_ON_WEN	0b	R0W1	Flag for enabling the writing to the MSTOP7_ON bit (bit 7) This bit is always read as 0. 0: Writing is disabled. 1: Writing is enabled.
22	MSTOP6_ON_WEN	0b	R0W1	Flag for enabling the writing to the MSTOP6_ON bit (bit 6) This bit is always read as 0. 0: Writing is disabled. 1: Writing is enabled.
21	MSTOP5_ON_WEN	0b	R0W1	Flag for enabling the writing to the MSTOP5_ON bit (bit 5) This bit is always read as 0. 0: Writing is disabled. 1: Writing is enabled.
20	—	0b	R	Reserved When read, the initial value is read. When writing, be sure to write the initial value. Operation is not guaranteed if a value other than the initial value is written.
19	MSTOP3_ON_WEN	0b	R0W1	Flag for enabling the writing to the MSTOP3_ON bit (bit 3) This bit is always read as 0. 0: Writing is disabled. 1: Writing is enabled.
18	MSTOP2_ON_WEN	0b	R0W1	Flag for enabling the writing to the MSTOP2_ON bit (bit 2) This bit is always read as 0. 0: Writing is disabled. 1: Writing is enabled.
17	MSTOP1_ON_WEN	0b	R0W1	Flag for enabling the writing to the MSTOP1_ON bit (bit 1) This bit is always read as 0. 0: Writing is disabled. 1: Writing is enabled.
16	MSTOP0_ON_WEN	0b	R0W1	Flag for enabling the writing to the MSTOP0_ON bit (bit 0) This bit is always read as 0. 0: Writing is disabled. 1: Writing is enabled.
15 to 8	—	All 0	R	Reserved Whenever it is read, 0 is read. The written value will be ignored.

Bit	Bit Name	Initial Value	R/W	Description
7	MSTOP7_ON	0b	RW	The state of BUS_REG1_MSTOP7_MXGIC operation is indicated. 0: Normal operation 1: Module stop state (MSTP)
6	MSTOP6_ON	0b	RW	The state of BUS_REG1_MSTOP6_MPTSIPG_OTP operation is indicated. 0: Normal operation 1: Module stop state (MSTP)
5	MSTOP5_ON	0b	RW	The state of BUS_REG1_MSTOP5_MHTSIPG operation is indicated. 0: Normal operation 1: Module stop state (MSTP)
4	—	0b	R	Reserved When read, the initial value is read. When writing, be sure to write the initial value. Operation is not guaranteed if a value other than the initial value is written.
3	MSTOP3_ON	0b	RW	The state of BUS_REG1_MSTOP3_MPDMAC_NS operation is indicated. 0: Normal operation 1: Module stop state (MSTP)
2	MSTOP2_ON	0b	RW	The state of BUS_REG1_MSTOP2_MXDMAC_NS operation is indicated. 0: Normal operation 1: Module stop state (MSTP)
1	MSTOP1_ON	0b	RW	The state of BUS_REG1_MSTOP1_MPDMAC_S operation is indicated. 0: Normal operation 1: Module stop state (MSTP)
0	MSTOP0_ON	0b	RW	The state of BUS_REG1_MSTOP0_MXDMAC_S operation is indicated. 0: Normal operation 1: Module stop state (MSTP)

7.2.4.144 MSTOP Register TZCDDR (CPG_BUS_TZCDDR_MSTOP)

This register indicates the stop state of individual modules.

Bit	31	30	29	28	27	26	25	24	23	22	21	20	19	18	17	16
	—	—	—	—	—	—	—	—	—	—	—	—	—	—	MSTOP1_ON_WEN	MSTOP0_ON_WEN
Initial Value	0	0	0	0	0	0	0	0	0	0	0	0	0	0	0	0
R/W	R	R	R	R	R	R	R	R	R	R	R	R	R	R	R0W1	R0W1
Bit	15	14	13	12	11	10	9	8	7	6	5	4	3	2	1	0
	—	—	—	—	—	—	—	—	—	—	—	—	—	—	MSTOP1_ON	MSTOP0_ON
Initial Value	0	0	0	0	0	0	0	0	0	0	0	0	0	0	0	0
R/W	R	R	R	R	R	R	R	R	R	R	R	R	R	R	RW	RW

Bit	Bit Name	Initial Value	R/W	Description
31 to 18	—	All 0	R	Reserved Whenever it is read, 0 is read. The written value will be ignored.
17	MSTOP1_ON_WEN	0b	R0W1	Flag for enabling the writing to the MSTOP1_ON bit (bit 1) This bit is always read as 0. 0: Writing is disabled. 1: Writing is enabled.
16	MSTOP0_ON_WEN	0b	R0W1	Flag for enabling the writing to the MSTOP0_ON bit (bit 0) This bit is always read as 0. 0: Writing is disabled. 1: Writing is enabled.
15 to 2	—	All 0	R	Reserved Whenever it is read, 0 is read. The written value will be ignored.
1	MSTOP1_ON	0b	RW	The state of BUS_TZCDDR_MSTOP1 operation is indicated. 0: Normal operation 1: Module stop state (MSTP)
0	MSTOP0_ON	0b	RW	The state of BUS_TZCDDR_MSTOP0 operation is indicated. 0: Normal operation 1: Module stop state (MSTP)

7.2.4.145 Other Function Register 2 (CPG_OTHERFUNC2_REG)

This register is used for miscellaneous functions.

Bit	31	30	29	28	27	26	25	24	23	22	21	20	19	18	17	16
	RES15_ON_WEN	RES14_ON_WEN	RES13_ON_WEN	RES12_ON_WEN	RES11_ON_WEN	RES10_ON_WEN	RES9_ON_WEN	RES8_ON_WEN	RES7_ON_WEN	RES6_ON_WEN	RES5_ON_WEN	RES4_ON_WEN	RES3_ON_WEN	RES2_ON_WEN	RES1_ON_WEN	RES0_ON_WEN
Initial Value	0	0	0	0	0	0	0	0	0	0	0	0	0	0	0	0
R/W	R0W1	R0W1	R0W1	R0W1	R0W1	R0W1	R0W1	R0W1	R0W1	R0W1	R0W1	R0W1	R0W1	R0W1	R0W1	R0W1

Bit	15	14	13	12	11	10	9	8	7	6	5	4	3	2	1	0
	RES15_SET	RES14_SET	RES13_SET	RES12_SET	RES11_SET	RES10_SET	RES9_SET	RES8_SET	RES7_SET	RES6_SET	RES5_SET	RES4_SET	RES3_SET	RES2_SET	RES1_SET	RES0_SET
Initial Value	0	0	0	0	0	0	0	0	0	0	0	0	0	0	0	0
R/W	RW	RW	RW	RW	RW	RW	RW	RW	RW	RW	RW	RW	RW	RW	RW	RW

Bit	Bit Name	Initial Value	R/W	Description
31 to 17	RESn_ON_WEN [n=15 to 1]	All 0	R0W1	Flags for enabling the writing to the RESn_SET bits. These bits are always read as 0. 0: Writing is disabled. 1: Writing is enabled.
16	RES0_ON_WEN	0b	R0W1	Flag for enabling the writing to the RES0_SET bit (bit 0) (DDR_RST_N). This bit is always read as 0. 0: Writing is disabled. 1: Writing is enabled.
15 to 1	RESn_SET [n = 15 to 1]	All 0	RW	No function is assigned to these bits. When the flags for enabling the writing are set to 1, these bits can be written to. The written value is read from these bits.
0	RES0_SET	0b	RW	The DDR_RST_N reset terminal is controlled. 0: Reset signal is applied (reset state). 1: Reset signal is stopped (released from the reset state).

Note: The change to the setting in this register is immediately reflected in the reset signal. Therefore, no register is provided to monitor the result of the change.

7.2.4.146 Clock Control Register MBUS (CPG_CLKON_MBUS)

This register is used to supply or stop clocks for individual modules.

Use this register only when switching SEL_PLL3_3. Reserved bit is prohibited from setting anything other than the initial value. The clocks listed in this register are not listed in the separate clock list.

Bit	31	30	29	28	27	26	25	24	23	22	21	20	19	18	17	16
	—	—	—	—	—	—	CLK9_ON_WEN	—	—	—	—	—	—	—	—	—
Initial Value	0	0	0	0	0	0	0	0	0	0	0	0	0	0	0	0
R/W	R	R	R	R	R	R	R0W1	R	R	R	R	R	R	R	R	R
Bit	15	14	13	12	11	10	9	8	7	6	5	4	3	2	1	0
	—	—	—	—	—	—	CLK9_ON	—	—	—	—	—	—	—	—	—
Initial Value	0	0	0	0	1	1	1	1	1	1	1	1	1	1	1	1
R/W	R	R	R	R	R	R	RW	R	R	R	R	R	R	R	R	R

Bit	Bit Name	Initial Value	R/W	Description
31 to 26	—	All 0	R	Reserved When read, the initial value is read. When writing, be sure to write the initial value. Operation is not guaranteed if a value other than the initial value is written.
25	CLK9_ONWEN	0b	R0W1	Flag for enabling the writing to the CLK9_ON bit (bit 9) This bit is always read as 0. 0: Writing is disabled. 1: Writing is enabled.
24 to 12	—	All 0	R	Reserved When read, the initial value is read. When writing, be sure to write the initial value. Operation is not guaranteed if a value other than the initial value is written.
11, 10	—	11b	R	Reserved When read, the initial value is read. When writing, be sure to write the initial value. Operation is not guaranteed if a value other than the initial value is written.
9	CLK9_ON	1b	RW	The MBUS_CLK9 clock is supplied or stopped. 0: Clock is stopped. 1: Clock is supplied.
8 to 0	—	All 1	R	Reserved When read, the initial value is read. When writing, be sure to write the initial value. Operation is not guaranteed if a value other than the initial value is written.

7.2.4.147 Clock Monitor Register MBUS (CPG_CLKMON_MBUS)

This register is used to monitor the state of the clocks supplied to individual modules.

The clocks listed in this register are not listed in the separate clock list.

Bit	31	30	29	28	27	26	25	24	23	22	21	20	19	18	17	16
	—	—	—	—	—	—	—	—	—	—	—	—	—	—	—	—
Initial Value	0	0	0	0	0	0	0	0	0	0	0	0	0	0	0	0
R/W	R	R	R	R	R	R	R	R	R	R	R	R	R	R	R	R
Bit	15	14	13	12	11	10	9	8	7	6	5	4	3	2	1	0
	—	—	—	—	—	—	CLK9_MON	—	—	—	—	—	—	—	—	—
Initial Value	0	0	0	0	1	1	1	1	1	1	1	1	1	1	1	1
R/W	R	R	R	R	R	R	R	R	R	R	R	R	R	R	R	R

Bit	Bit Name	Initial Value	R/W	Description
31 to 12	—	All 0	R	Reserved When read, the initial value is read. When writing, be sure to write the initial value. Operation is not guaranteed if a value other than the initial value is written.
11, 10	—	11b	R	Reserved When read, the initial value is read. When writing, be sure to write the initial value. Operation is not guaranteed if a value other than the initial value is written.
9	CLK9_MON	1b	R	The state of the MBUS_CLK9 clock is monitored. 0: Clock is stopped. 1: Clock is supplied.
8 to 0	—	All 1	R	Reserved When read, the initial value is read. When writing, be sure to write the initial value. Operation is not guaranteed if a value other than the initial value is written.

7.3 Functions of the CPG

This section describes the functions of the CPG.

7.3.1 Clock Control

The CPG has the following five types of clock control functions.

- PLL control, setting, and monitoring functions
- Clock frequency dividers and selectors
- Fixed frequency dividers
- Clock enabling function

7.3.1.1 PLL Control, Setting, and Monitoring Functions

This section describes the functions for controlling, setting, and monitoring the PLL (PLL1 to PLL4 and, PLL6).

The PLL is controlled through the registers in the CPG.

The PLL control module counts the PLL lock wait time to generate the PLL lock signal and it is used to control the PLL output clocks by the CGC so that invalid clocks are not output before the PLL is locked.

The reset state and lock state of the PLL can be monitored through registers in the CPG.

The following shows the PLL control, setting, and monitoring functions.

- PLL operating mode control
- Output clock setting
- PLL reset and lock state monitoring

These functions are described in detail in the following sections.

(1) PLL Operating Mode Control

The CPG registers are used to specify the SSCG PLL operating mode and make SSCG settings.

The normal mode or standby mode can be selected as the operating mode.

The following can be set up through CPG registers.

- Operating mode setting (normal mode or standby mode)
- SSCG enable or disable setting (valid in the normal mode)

The following table shows the registers to be used.

For details of the settings, refer to the functional description of the target register.

Table 7.6 Registers for Controlling the PLL Operating Mode

Register Name	Abbreviation	Function
PLL _n (SSCG) standby control registers	CPG_SAMPLL _n _STBY (n = 1, 4, or 6)	Standby mode setting (reset state) and SSCG enable or disable setting

(2) Output Clock Setting

The CPG registers are used to specify the clocks output from the PLL.

The following values can be set up.

- Output clock frequency setting
- SSCG modulation value setting

Table 7.7 Registers for Setting PLL Output Clocks

Register Name	Abbreviation	Function
PLL _n (SSCG) output clock setting register 1	CPG_SAMPLL _n _CLK1	Frequency setting
PLL _n (SSCG) output clock setting register 2	CPG_SAMPLL _n _CLK2	Frequency setting and SSCG modulation value setting

Note: n = 1, 4, or 6

(3) PLL State Monitoring

The reset state and lock state of the PLL can be monitored through CPG registers.

The following table shows the registers to be used.

Table 7.8 Registers for Monitoring the PLL State

Register Name	Abbreviation	Function
PLL _n monitor registers	CPG_SAMPLL _n _MON (n = 1, 4, or 6) CPG_SIPLL _n _MON (n = 2 or 3)	PLL state monitoring

(4) SSCG Switching in PLL3

In PLL3, the SSCG function is enabled or disabled through the MD_CLKS signal from the SYSC.

The state of the MD_CLKS signal is determined when the LSI is released from the system reset (PRST#) state and the signal state does not change after the system is activated.

The SSCG enabled or disable state in PLL3 cannot be switched through register settings.

MD_CLKS = 0: SSCG is disabled.

MD_CLKS = 1: SSCG is enabled.

7.3.1.2 Clock Frequency Dividers and Selectors

The CPG uses several frequency dividers and selectors to provide appropriate clocks that meet the specifications of individual modules. The frequency dividers and selectors are classified into the dynamic switching type that can be switched without generating a glitch and the static switching type that should be switched after the clock for the target module is stopped because a glitch is generated if this type of divider or selector is switched while the clock is supplied.

The following frequency dividers and selectors are provided.

- Fixed frequency dividers
- Dynamic switching selectors
- Dynamic switching variable-frequency dividers
(with a duty ratio of 50:50 when divided by an even number)
- Static switching selectors
- Static switching variable-frequency dividers
(with a duty ratio of 50:50 when divided by an even number)

A specific procedure should be used to switch each frequency divider or selector. Refer to **Section 7.4.5, Procedure for Switching the Division Ratio of the Dynamic Switching Frequency Dividers**, **Section 7.4.6, Procedure for Switching Clocks by the Dynamic Switching Frequency Selectors**, and **Section 7.4.7, Procedure for Switching Clocks by the Static Switching Frequency Dividers and Selectors (Procedure for Switching Source Clocks)**.

7.3.1.3 Fixed Frequency Dividers

A fixed frequency divider uses a fixed division value. The CPG provides 1/2, 1/4, 1/8, 1/10, 1/16, and 1/32 dividers, and all fixed dividers generate clocks with a duty ratio of 50:50.

7.3.1.4 PLL Clock Monitoring

This function monitors whether the PLL1 to PLL4 and, PLL6 output clocks are operating.

The frequency in the CPG is divided to obtain the frequency that can be monitored through the external pin of this LSI and then output to the upper layer.

The following table shows the instance names and clock frequencies of the monitor points.

Table 7.9 Instance Names and Clock Frequencies of the Monitor Points

PLL Name	Instance Name of Monitor Point	Maximum Frequency (MHz)	Divider Value	Output Clock Frequency (MHz)
PLL1	CPG_CTL/PLL1/FOUT	1200	32	38
PLL2	CPG_CTL/PLL2/FOUT1PH0	1600 (1/2 of 3200)	32	50
PLL2	CPG_CTL/PLL2/FOUT3	533 (1/6 of 3200)	16	34
PLL3	CPG_CTL/PLL3/FOUT1PH0	1600 (1/2 of 3200)	32	50
PLL3	CPG_CTL/PLL3/FOUT3	533 (1/6 of 3200)	16	34
PLL3	CPG_CTL/PLL3/FOUT4	400 (1/8 of 3200)	8	50
PLL4	CPG_CTL/PLL4/FOUT	1600	32	50
PLL6	CPG_CTL/PLL6/FOUT	500	16	32

7.3.2 Clock Generation and Control Functions

The following types of reset are provided.

Table 7.10 Reset Types

No.	Type	Method	Source	Range of Reset
1	System reset	Hardware reset	Reset by PRST#	All
2		WDT system reset	WDT overflow, etc.	All (The WDTOVF register is excluded.)
3	Module reset	WDT system reset	WDT overflow, etc.	CPU corresponding to each WDT
4		Software reset	Control through CPG registers	individual on-chip modules

7.3.2.1 Range of Reset Application

The following shows the application (target) range of the reset generated by each reset source.

- (1) Hardware sources (PRST#, TRST#, and DEBUG)
- (2) WDT system reset sources

Table 7.11 Range of Reset Application

No.	Operating Mode DEBUG	Reset Source			JTAG Interface*3	Range of Reset Application					Description of Reset
		Debug Reset TRST#	System Reset PRST#	WDT Reset		Modules Related to Debugging*2		WDT		All Modules (Excluding *1,*2,*3)	
						ncepldm 200	ncejdtm 200	Reset for WDTOVF Register*1	AX45MP		
1	X	X	0	X	Reset	Reset	Reset	Reset	Reset	Reset	Hardware system reset
2	0	0	1	0	Reset	Reset	Reset	Released	Reset*4	Reset*3	WDT system reset
3	0	0	1	1	Reset	Reset	Reset	Released	Released	Released	Normal operation state
4	0	1	1	1	Reset	Reset	Reset	Released	Released	Released	Normal operation state
5	1	0	1	0	Reset*3	Reset	Reset	Released	Reset*4	Reset*3	WDT system reset
6	1	1	1	X	Reset	Released*5	Released*5	Reset	Reset	Reset	non-debug-module reset (ndmreset)
7	1	1	1	0	Reset	Released*5	Released*5	Released	Reset*4	Reset*3	Software reset
8	1	1	1	0	Reset*3	Released*5	Released*5	Released	Reset*4	Reset*3	WDT system reset*6

Note 1. It is reset by the WDTOVF register and PRST#.

Note 2. AX45MP debugging related circuit

Note 3. It is reset when System reset is executed by WDTRST_SEL.

Note 4. It is reset when AX45MP is reset by WDTRST_SEL.

Note 5. AX45MP debug circuit reset is not subject to WDT system reset.

7.3.2.2 System Reset (External Pin)

A system reset is applied when the reset signal from the external PRST# pin is asserted and it initializes the entire LSI.

7.3.2.3 WDT System Reset

This LSI has three WDT channels and the CPG issues a reset request when any of the following sources is generated.

WDT Channel	Target of Monitoring	Function
Channel 0	AX45MP	Reset due to a parity error in AX45MP

(1) WDT System Reset Circuit

The reset requests from WDT channel can be assigned to the desired signals shown below by using the masking function specified through the settings of the WDTRSTSEL register implemented in the CPG.

If a bit in the WDTRSTSEL register is set to 1, the corresponding signal is asserted when the WDT issues a reset request.

Target of Monitoring	Function
WDT system reset	The reset request signal WDTRST# is sent to the reset generation circuit to apply a system reset.
WDTOVF_PERROUT	The WDTOVF_PERR signal is asserted to notify the external devices of the application of a system reset.
AX45MP cold reset	A cold reset request is issued when either WDT channel 0 detects an error.

Bit	Bit Name	Initial Value	R/W	Reset Source Module	Function
0	WDTRSTSEL0	0	R/W	WDT (channel 0) AX45MP	When the corresponding WDT issues a reset request due to an overflow, etc. 0: WDT system reset is masked. 1: WDT system reset is applied.
1	Reserved	0	R	—	—
2	Reserved	0	R	—	—
3	Reserved	1	R	—	—
4	WDTRSTSEL4	0	R/W	WDT (channel 0) AX45MP	When the corresponding WDT issues a reset request due to an overflow, etc. 0: Assertion of WDTOVFOUT is masked. 1: WDTOVFOUT is asserted.
5	Reserved	0	R	—	—
6	Reserved	0	R	—	—
7	Reserved	1	R	—	—
8	WDTRSTSEL8	0	R/W	WDT (channel 0) AX45MP	When either WDT channel 0 issues a reset request*1,*2 0: Cold reset of the AX45MP is masked. 1: Cold reset of the AX45MP is applied.
9	Reserved	0	R	—	—
10	Reserved	0	R	—	—

Note 1. When an error occurs in AX45MP, a cold reset is applied.

Note 2. For the timing of the cold reset in the AX45MP, refer to **Section 7.3.2.3(4), Timing of AX45MP Cold Reset due to the WDT Source**.

(2) WDTOVF_PERROUT Signal

This is an external signal that notifies the system that the WDT has applied a WDT system reset to this LSI.

If another WDT system reset is requested before the output of this signal pulse is completed, it is ignored.

The GPIO settings of the WDTOVF_PERROUT# pin such as the driving capability are reset by the GPIO_RST_WDTOVFN signal for the CPG_WDTOVFRST[3:0] register bits.

The following shows the sequence of reset by the WDT.

- (1) The WDT channel selected by the WDTRSTSEL[7:4] bits generates a reset request.
- (2) The CPG applies a WDT system reset.
- (3) 64 cycles of the 24-MHz clock are waited.
* This is the period until the necessary settings are reflected in the entire LSI.
- (4) A low pulse is output from the WDTOVF_PERROUT pin for 64 cycles of the 24-MHz clock.
- (5) 64 cycles of the 24-MHz clock are waited.
- (6) Issue a system reset.
- (7) After 191CLK with 24MHz clock, deassert WDT system reset and execute boot sequence.

(3) WDT Overflow System Reset Register (CPG_WDTOVF_RST)

After the release from the WDT system reset applied by the WDT system reset circuit in response to a reset request such as a WDT overflow, this register is used to identify the WDT channel that generated the reset request.

This register is not reset by the WDT system reset generated by the WDT.

If a WDT system reset is not applied according to the WDTRSTSEL register setting, the WDT is not reset and the source of the reset request can be identified by checking the interrupt from the WDT and the status register in the WDT.

Table 7.12 WDT Overflow System Reset Register (CPG_WDTOVF_RST)

Bit	Bit Name	Initial Value	R/W	Reset Source Module	Function
0	WDTOVF0	0	R/W	WDT (channel 0) AX45MP	When a WDT channel has applied a WDT system reset, the corresponding bit is set to 1. These bits are cleared by writing 1.
1	Reserved	0	R	—	—
2	Reserved	0	R	—	—
15 to 3	Reserved	0	R	—	—
16	WDTOVF0_WEN	0	R/W1	—	Writing to the WDTOVF0 bit (bit 0) is masked. This bit is always read as 0. 0: Writing is disabled. 1: Writing is enabled.
17	Reserved	0	R	—	—
18	Reserved	0	R	—	—
31 to 19	Reserved	0	R	—	—

(4) Timing of AX45MP Cold Reset due to the WDT Source

The following figure shows the timing of the cold reset for the AX45MP alone due to the WDT source.

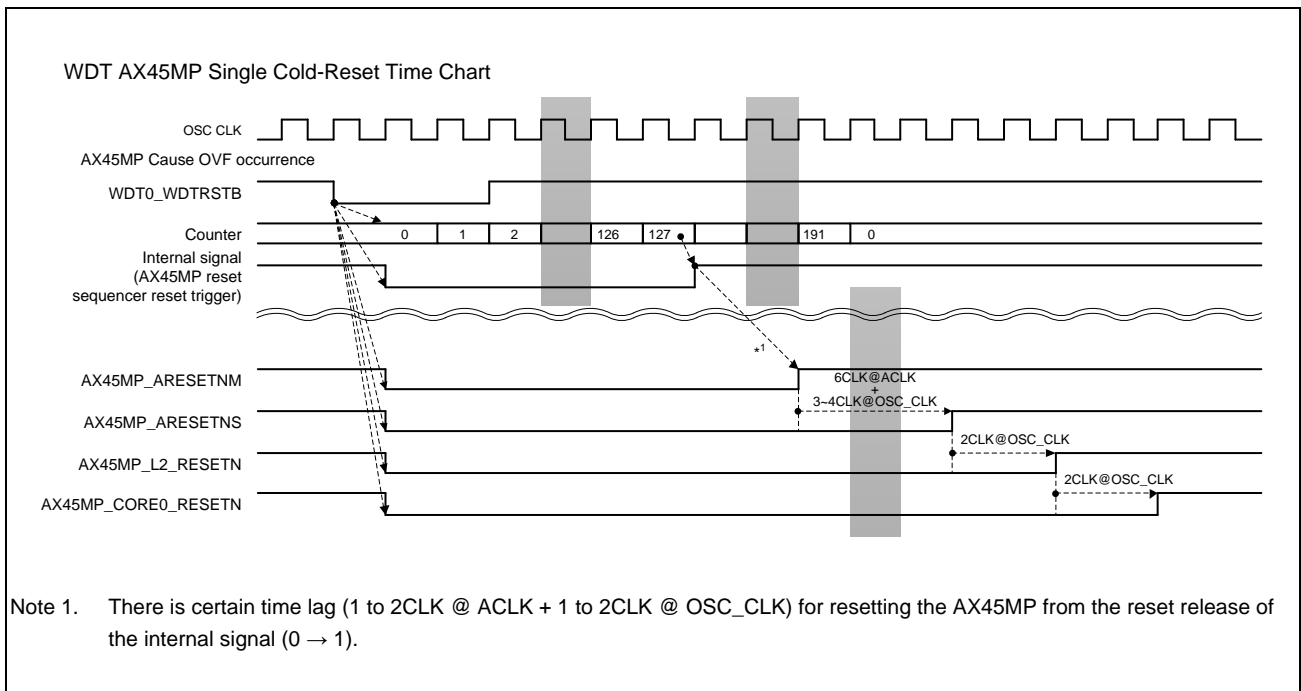

Figure 7.4 Timing of Cold Reset for the AX45MP Alone due to the WDT Source

7.3.2.4 Module Reset Application Control

The application of a reset is controlled for individual modules.

In addition to a reset applied to individual modules according to register settings by software, some modules are reset in a certain reset mode.

For register setting specifications, refer to the descriptions of the reset control register *** (CPG_RST_***).

For a clock that is controlled by the corresponding CGC and is synchronized with a reset signal, the processing for stopping the clock is performed at the release of the reset state.

7.4 Operating Procedures

This section describes the procedures for operating the CPG.

7.4.1 Procedures for Supplying and Stopping Module Clocks

Use the following procedures to switch between the supply and stop of the target clock for a module.

* Sample procedures for the SRAM_MCPU clock (SRAM_MCPU_ACLK) are described here.

Supplying a Clock:

1. Setting the register for supplying the SRAM_MCPU clock (SRAM_MCPU_ACLK)

Set up the following bits in the clock control register SRAM_MCPU (CPG_CLKON_SRAM_MCPU).

— Setting for supplying the clock: Bit 0 (CLK0_ON) = 1 and bit 16 (CLK0_ONWEN) = 1

2. Confirming that the output of the SRAM_MCPU clock (SRAM_MCPU_ACLK) has started

Read the following bit in the clock monitor register SRAM_MCPU (CPG_CLKMON_SRAM_MCPU) to confirm that the output of the clock has started.

— Clock state: Bit 0 (UNIT0_CLK_MON), 1: Clock is supplied. (0: Clock is stopped.)

Stopping a Clock:

1. Setting the register for stopping the SRAM_MCPU clock (SRAM_MCPU_ACLK)

Set up the following bits in the clock control register SRAM_MCPU (CPG_CLKON_SRAM_MCPU).

— Setting for stopping the clock: Bit 0 (CLK0_ON) = 0 and bit 16 (CLK0_ONWEN) = 1

2. Confirming that the output of the SRAM_MCPU clock (SRAM_MCPU_ACLK) has been stopped

Read the following bit in the clock monitor register SRAM_MCPU (CPG_CLKMON_SRAM_MCPU) to confirm that the output of the clock has been stopped.

— Clock state: Bit 0 (UNIT0_CLK_MON), 0: Clock is stopped. (1: Clock is supplied.)

The following registers are used in the above procedures.

— 7.2.4.x Clock control registers ***** (CPG_CLKON_*****)

— 7.2.4.x Clock monitor registers ***** (CPG_CLKMON_*****)

For the procedures for supplying and stopping a clock signal, refer also to the section on the target module. If specific procedures for the module are described, use them.

7.4.2 Procedures for Supplying and Stopping Reset Signals

Use the following procedures to switch between the supply (reset state) and stop (released from the reset state) of the target reset signal for a module.

* Sample procedures for the SRAM_MCPU reset (SRAM_MCPU_ARESETN) are described here.

Supplying a Reset Signal:

1. Setting the register for supplying the SRAM_MCPU reset signal (SRAM_MCPU_ARESETN)

Set up the following bits in the reset control register SRAM_MCPU (CPG_RST_SRAM_MCPU).

— Setting for supplying the reset signal: Bit 0 (UNIT0_RSTB) = 0 and bit 16 (UNIT0_RST_WEN) = 1

2. Confirming that the output of the SRAM_MCPU reset signal (SRAM_MCPU_ARESETN0) has been started

Read the following bit in the reset monitor register SRAM_MCPU (CPG_RSTMON_SRAM_MCPU) to confirm that the output of the reset signal has been started.

— Reset state: Bit 1 (UNIT0_RST_MON)

0: Reset signal is stopped (released from the reset state)

1: Reset signal is output.

Stopping a Reset Signal:

1. Setting the register for stopping the SRAM_MCPU reset signal (SRAM_MCPU_ARESETN)

Set up the following bits in the reset control register SRAM_MCPU (CPG_RST_SRAM_MCPU).

— Setting for stopping the reset signal: Bit 0 (UNIT0_RSTB) = 1 and bit 16 (UNIT0_RST_WEN) = 1

2. Confirming that the output of the SRAM_MCPU reset signal (SRAM_MCPU_ARESETN) has been stopped

Read the following bit in the reset monitor register SRAM_MCPU (CPG_RSTMON_SRAM_MCPU) to confirm that the output of the reset signal has been stopped.

— Reset state: Bit 0 (UNIT0_RST_MON)

0: Reset signal is stopped (released from the reset state)

1: Reset signal is output.

The following registers are used in the above procedures.

— 7.2.4.x Reset control registers ***** (CPG_RST_*****)

— 7.2.4.x Reset monitor registers ***** (CPG_RSTMON_*****)

For the procedures for supplying and stopping a reset signal, refer also to the section on the target module. If specific procedures for the module are described, use them.

7.4.3 Procedure for Activating Modules

Use the following procedure to activate an inactive module after a system reset.

For the specific procedure for activating the target module, refer to the section on the module.

1. Set up the clock control register for the clock signal connected to the target module to start the supply of the clock. Note that the PLL for the clock should be started before the clock if the PLL is stopped.
2. Read the clock monitor register to confirm that the supply of the target clock has started.
3. Set up the reset control register for the reset signal connected to the target module to release the module from the reset state.
4. Read the reset monitor register to conform that the module has been released from the reset state.

7.4.4 Procedures for PLL Setup

The following shows the procedures for PLL setup.

7.4.4.1 Procedure for Setting PLL Normal Mode (Changing the Output Clock and SSCG Mode)

Use the following procedure to shift the PLL from the standby mode to the normal mode (change the output clock and SSCG mode).

[n = 1, 4, or 6: PLL1, PLL4, or PLL6]

1) Confirming the PLL operating mode (confirming that the PLL is in the standby mode)

- Check the following bit in the PLLn (SSCG) monitor register (CPG_SAMPLLn_MON).
- Shift to the standby mode: Confirm that bit 0 (PLLn_RESETB) = 0 (standby mode).
- Check the following bit in the PLLn (SSCG) monitor register (CPG_SAMPLLn_MON).
- Unlock of PLL: Confirm that bit 4 (PLLn_LOCK) = 0 (PLL is not locked).

Wait until the above conditions are satisfied.

2) Setting the output clock 1

- Modify the following bits in PLLn (SSCG) output clock setting register 1 (CPG_SAMPLLn_CLK1).
- For details of the settings, refer to **Section 7.2.4, Register Descriptions**.
- Setting of output clock (desired setting): Bits 5 to 0 (DIV_P_5 to DIV_P_0), bits 15 to 6 (DIV_M_9 to DIV_M_0), and bits 31 to 16 (DIV_K_15 to DIV_K_0)

3) Setting the output clock and SSCG modulation value 2

- Modify the following bits in PLLn (SSCG) output clock setting register 2 (CPG_SAMPLLn_CLK2).
- For details of the settings, refer to **Section 7.2.4, Register Descriptions**.
- Setting of output clock (desired setting): Bits 2 to 0 (DIV_S_2 to DIV_S_0)
- Setting of SSCG modulation value (desired setting): Bits 13 to 8 (MRR_5 to MRR_0) and bits 23 to 16 (MFR_7 to MFR_0)

4) Setting the PLL normal mode

- Set up the following bits in the PLLn (SSCG) standby control register (CPG_SAMPLLn_STBY).
- Setting of operating mode: Bit 0 (RESETB) = 1 (normal mode)
- Setting of SSCG mode: Bit 2 (SSCG_EN) = Desired setting

5) Confirming the shift to the PLL normal mode and the stable output of the clock

- Check the following bit in the PLLn (SSCG) monitor register (CPG_SAMPLLn_MON).
- Shift to standby mode: Confirm that bit 0 (PLLn_RESETB) = 1 (normal mode).
- Check the following bit in the PLLn (SSCG) monitor register (CPG_SAMPLLn_MON).
- Lock of PLL: Confirm that bit 4 (PLLn_LOCK) = 1 (PLL is locked).

Wait until the above conditions are satisfied.

NOTE

If there is no change in a parameter in step (2) or (3), the corresponding register does not need to be modified.

7.4.4.2 Procedure for Setting PLL Standby Mode

Use the following procedure to shift the PLL from the normal standby mode to the standby mode.

[n = 1, 4, or 6: PLL1, PLL4, or PLL6]

1) Setting the PLL standby mode

- Set the following bits of the PLLn (SSCG) standby control register (CPG_SAMPLLn_STBY).
- Operation mode setting: bit0 (RESETB) = 0 (standby mode) (other bits are "0").

2) Confirming the shift to the PLL standby mode

- Check the following bits of the PLLn (SSCG) monitor register (CPG_SAMPLLn_MON).
- Standby mode transition confirmation: bit0 (PLLn_RESETB) = 0 (standby mode).
- Check the following bits of the PLLn (SSCG) monitor register (CPG_SAMPLLn_MON).
- Confirmation of PLL lock release: bit4 (PLLn_LOCK) = 0 (PLL is not locked).

Wait until the above conditions are satisfied.

7.4.4.3 PLLs with Restrictions

PLL1 to PLL3 cannot be switched to desired clock settings by the user because these PLLs output clocks for the CPU and bus operation.

The PLL2 and PLL3 settings cannot be modified after booting because these PLLs output system clocks for bus operation.

PLL4 and PLL6 can be set up, started, or stopped by the user at the desired timing under the allowable conditions of use for the target module.

7.4.5 Procedure for Switching the Division Ratio of the Dynamic Switching Frequency Dividers

Use the following procedure to set the division ratio of the dynamic switching frequency dividers.

* A sample procedure for DIV_PLL2_A is described here.

1) Confirming the DIV_PLL2_A state (checking that it is not busy)

- Check the following bit in the clock status monitor register (CPG_CLKSTATUS).
- DIV_PLL2_A state: Confirm that bit 0 (DIVPL2A_STS) = 0 (switching is completed).

Wait until the above condition is satisfied.

2) Setting the DIV_PLL2_A division ratio

- Set up the following bits in the division ratio setting (PLL2) register (CPG_PL2_DDIV).
- Setting of division ratio: Bits 1 and 0 (DIVPL2A_SET) = desired value and bit 16 (DIV_PLL2_A_WEN) = 1

3) Confirming the DIV_PLL2_A state (checking that it is not busy)

- Check the following bit in the clock status monitor register (CPG_CLKSTATUS).
- DIV_PLL2_A state: Confirm that bit 0 (DIVPL2A_STS) = 0 (switching is completed).

Wait until the above condition is satisfied.

The following registers are used in the above procedure.

- Division ratio setting (PLL1) register (CPG_PL1_DDIV)
- Division ratio setting (PLL2) register (CPG_PL2_DDIV)
- Division ratio setting (PLL3) register (CPG_PL3A_DDIV)
- Division ratio setting (PLL3) register (CPG_PL3B_DDIV)

The following status monitor register is used.

- Clock status monitor register (CPG_CLKSTATUS)

When 1 is written to a xx_WEN bit placed in the upper 16 bits of a division ratio setting register, the clock switching control begins even if the settings in the lower bits are not changed. Check the status monitor register (CPG_CLKSTATUS) and wait until the switching is completed. The clock will temporarily stop at the timing of switching.

7.4.6 Procedure for Switching Clocks by the Dynamic Switching Frequency Selectors

Use the following procedure to switch clocks by the dynamic switching frequency selectors.

* A sample procedure for SEL_PLL4 is described here.

1) Confirming the SEL_PLL4 state (checking that it is not busy)

- Check the following bit in the clock status monitor register (CPG_CLKSTATUS).
- SEL_PLL4 state: Confirm that bit 31 (SELPLL4_STS) = 0 (switching is completed).

Wait until the above condition is satisfied.

2) Setting the switching of the clock output from SEL_PLL4

- Set up the following bits in the source clock setting (DDR) register (CPG_PL4_DSEL).
- Setting of clocks switching (switch from PLL4 to OSC_DIV1000): Bits 31 to 0 = H'0001_0000
(switch from OSC_DIV1000 to PLL4): Bits 31 to 0 = H'0001_0001

Confirming the SEL_PLL4 state (checking that it is not busy)

- Check the following bit in the clock status monitor register (CPG_CLKSTATUS).
- SEL_PLL4 state: Confirm that bit 31 (SELPLL4_STS) = 0 (switching is completed).

Wait until the above condition is satisfied.

The following registers are used in the above procedure.

- Source clock setting (DDR) register (CPG_PL4_DSEL)
- Source clock setting (SDHI) register (CPG_PL2SDHI_DSEL)

When 1 is written to a xx_WEN bit placed in the upper 16 bits of a source clock setting register, the clock switching control begins even if the settings in the lower bits are not changed. Check the status monitor register (CPG_CLKSTATUS) and wait until the switching is completed. The clock will temporarily stop at the timing of switching.

7.4.7 Procedure for Switching Clocks by the Static Switching Frequency Dividers and Selectors (Procedure for Switching Source Clocks)

Use the following procedure to set the division ratio of the static switching frequency dividers and to switch clocks by the static switching frequency selectors.

When a source clock is active: Stop the clock. → Make settings for switching clocks. → Start the clock.

When a source clock is stopped: Make settings for switching.

The following registers are used in the above procedure.

— Source clock setting register (CPG_PL3_SSEL)*1

Note 1. When switching SEL_PLL3_3 in CPG_PL3_SSEL, please note the following points.

- 1) Do not access SPI-Multi during switching.
- 2) If a TZC2INT interrupt is occurring, allow the interrupt to complete before stopping the clock on the CPG_CLKON_MBUS.
- 3) Before switching, stop the following clocks.
 - CPG_CLKON_SPI_MULTI (bit1, bit0)
 - CPG_CLKON_MBUS (bit9)
- 4) CPG_CLKON_SPI_MULTI and CPG_CLKON_MBUS are not in the order to stop the clock.

7.4.8 Boot Sequence (Normal Operation)

After the reset sequence ends, perform the following operations if necessary.

- Start PLLs.
- Set up clock selectors.
- Set up clock division ratios.
- Supply clocks to modules.
- Release modules from the reset state.

7.4.9 Boot Sequence (Debug Mode)

After the reset sequence (debug mode) ends, perform the following operations if necessary.

- Start PLLs.
- Set up clock selectors.
- Set up clock division ratios.
- Supply clocks to modules.
- Release modules from the reset state.

7.4.10 General Operating Procedures

The following describes general operating procedures.

7.4.10.1 Procedure for Writing to Registers

The registers in the CPG have write-enable flags in the upper 16 bits and normal data fields in the lower 16 bits except for the registers shown below. Therefore, only the desired bit can be modified without read-modify-write operation.

To modify the value of a bit, write 1 to the write-enable flag having the target bit number + 16 and write a desired value to the target bit.

(Examples: To modify bit 0 to 1b, write H'0001_0001. To modify it to 0b, write H'0001_0000. When H'0000_xxxx is written, the value of bits 15 to 0 does not change.)

NOTE

In some registers, a single write-enable flag controls multiple data bit. Refer to the description of each register.

Registers that have data fields in the upper bits instead of write-enable flags:

- PLLn (SSCG) output clock setting register 1 (CPG_SAMPLLn_CLK1): (n = 1, 4, or 6)
- PLLn (SSCG) output clock setting register 2 (CPG_SAMPLLn_CLK2): (n = 1, 4, or 6)

8. Interrupt Controller

The interrupt controller decides the priority of interrupt sources and controls interrupt requests to the CPU.

The interrupt controller registers set the order of priority of each interrupt, allowing the user to process interrupt requests according to the user-set priority.

8.1 Features

■ Equipped with Andes Platform-Level Interrupt Controller (PLIC)*¹ for AX45MP.

PLIC for external interrupt and internal interrupt

- 511-bit interrupt sources
- 255 priority levels
- Supported: M-Mode/S-Mode/U-Mode
- Supported: NonVector/Vector Mode
- Not Supported: Preemptive Priority Interrupt
- Not supported: Nested Interrupt

■ External Interrupts

- NMI, IRQ0-7, TINT0-31
- Noise filter function.*²

■ Internal Interrupts

- On-chip peripheral interrupts
- On-chip Bus error interrupts
- On-chip RAM ECC error interrupts

■ PLIC for software interrupt

- 31-bit interrupt sources
- 31 priority levels
- Supported: M-Mode

Note 1. Refer to AndesCore™ AX45MP-1C Processor Reference Manual.

Note 2. Refer to **Section 41, General Purpose Input Output Port (GPIO)**.

8.1.1 External Signal Pins

The following table shows external signal pins for Interrupt Controller.

Table 8.1 External Signal Pins

Name	Width	I/O	Description
NMI	1	I	NMI (Non Maskable Interrupt) pin. Refer to Section 8.7.1 .
IRQ0 – IRQ7	8	I	IRQ (Interrupt Request) pins. GPIO pins can be used as IRQ pins. Refer to Section 8.7.2 .
P0_0 – P18_5	82	I	GPIO pins. GPIO pins can be used as external interrupt input pins (GPIOINT0-81). Assign only 32 pins in GPIOINT0-81 to TINT0-31. Refer to Section 8.7.3 .

8.1.2 Block Diagram

The block diagram of Interrupt Controller is as follows.

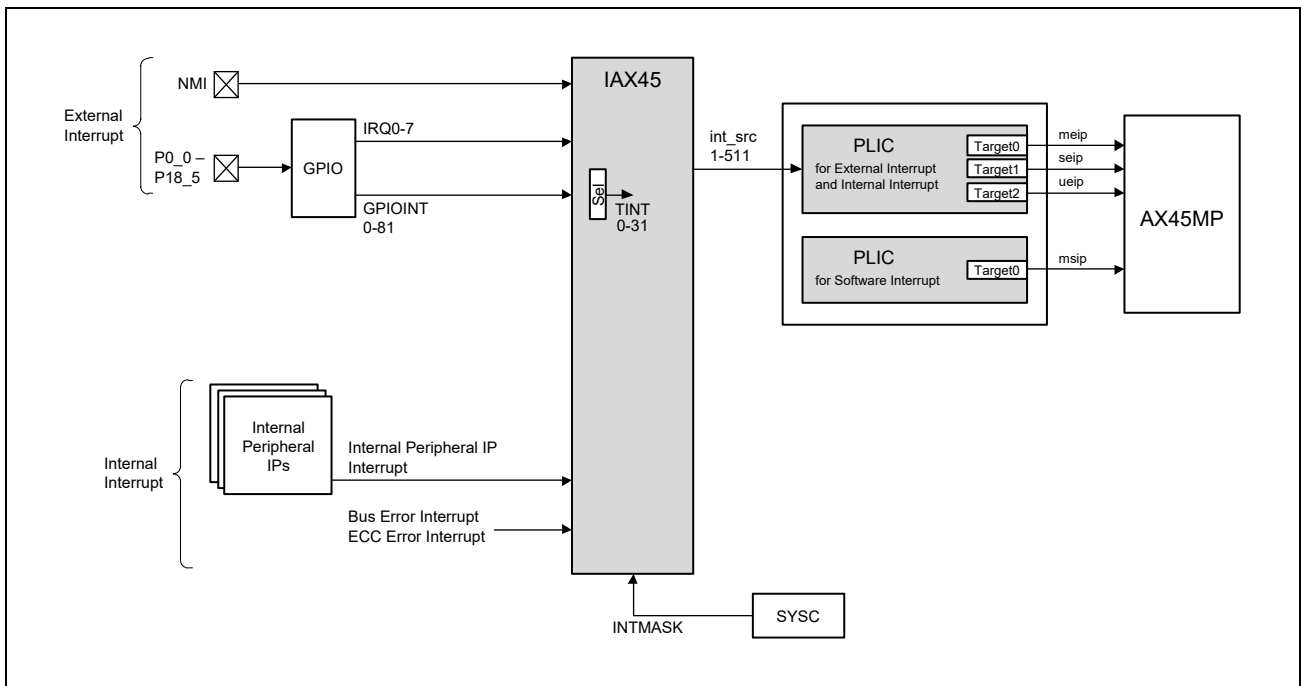

Figure 8.1 Interrupt Controller Block Diagram

PLIC

PLIC is Andes Platform-Level Interrupt Controller (PLIC) for AX45MP.

Two types of PLIC are equipped. One is for external interrupt and internal interrupt. The other is for software interrupt.

IAX45

IAX45 performs various interrupt controls including synchronization for the external interrupts of NMI, IRQ, and GPIOINT and the interrupts of the built-in peripheral interrupts output by each module. And it notifies the interrupt to the PLIC.

- Select 32 TINT from 82 GPIOINT.
- Integration of bus error interrupts from system bus.
- Integration of ECC error interrupts from On-chip RAM.
- Indicate interrupt status. (NMI, IRQ, TINT, integrated bus error interrupt and integrated ECC error interrupt)
- Setting of interrupt detection method. (NMI, IRQ and TINT)
- All interrupts are masked by INTMASK.
- Mask function for NMI, IRQ and TINT.

8.2 Interrupt Mapping

The following table indicates interrupt mapping for PLIC external interrupt and internal interrupt.

Refer to **Section 14, Direct Memory Access Controller** with the interrupts through DMA Controller, and **Section 8.8.1**.

Table 8.2 Interrupt mapping (1/13)

Interrupt Source*2	Cause of Interrupt	Interrupt ID (PLIC int_src[])	Interrupt Type*1	Note
Reserved	—	1	—	
Reserved	—	2	—	
Reserved	—	3	—	
Reserved	—	4	—	
Reserved	—	5	—	
Reserved	—	6	—	
Reserved	—	7	—	
Reserved	—	8	—	
Reserved	—	9	—	
Reserved	—	10	—	
Reserved	—	11	—	
Reserved	—	12	—	
Reserved	—	13	—	
Reserved	—	14	—	
Reserved	—	15	—	
Reserved	—	16	—	
Reserved	—	17	—	
Reserved	—	18	—	
Reserved	—	19	—	
Reserved	—	20	—	
Reserved	—	21	—	
Reserved	—	22	—	
Reserved	—	23	—	
Reserved	—	24	—	
Reserved	—	25	—	
Reserved	—	26	—	
Reserved	—	27	—	
Reserved	—	28	—	
Reserved	—	29	—	
Reserved	—	30	—	
Reserved	—	31	—	
NMI pin	NMI	32	Level	*3

Table 8.2 Interrupt mapping (2/13)

Interrupt Source*2	Cause of Interrupt	Interrupt ID (PLIC int_src[])	Interrupt Type*1	Note
IRQ pins	IRQ0	33	Level	*4
	IRQ1	34	Level	*4
	IRQ2	35	Level	*4
	IRQ3	36	Level	*4
	IRQ4	37	Level	*4
	IRQ5	38	Level	*4
	IRQ6	39	Level	*4
	IRQ7	40	Level	*4
Reserved	—	41	—	
Reserved	—	42	—	
Reserved	—	43	—	
Reserved	—	44	—	
Reserved	—	45	—	
Reserved	—	46	—	
Reserved	—	47	—	
Reserved	—	48	—	
Reserved	—	49	—	
Reserved	—	50	—	
Reserved	—	51	—	
Reserved	—	52	—	
Reserved	—	53	—	
Reserved	—	54	—	
Reserved	—	55	—	
Reserved	—	56	—	
System Bus	BUS_ERR_INT	57	Level	*6
System Bus (TZC for SRAM ACPU)	TZC0INT	58	Level	
System Bus (TZC for SRAM MCPU)	TZC1INT	59	Level	
System Bus (TZC for SPI Multi)	TZC2INT	60	Level	
System Bus (TZC for DDR MEMC)	TZC3INT	61	Level	
Reserved	—	62	—	
Reserved	—	63	—	
Reserved	—	64	—	
Reserved	—	65	—	
ECCRAM0	EC7TIE1_0	66	Edge	*7
	EC7TIE2_0	67	Edge	*7
	EC7TIOVF_0	68	Edge	*7
ECCRAM1	EC7TIE1_1	69	Edge	*7
	EC7TIE2_1	70	Edge	*7
	EC7TIOVF_1	71	Edge	*7
DDR3L/4	controller_int	72	Level	
Reserved	—	73	—	
Reserved	—	74	—	

Table 8.2 Interrupt mapping (3/13)

Interrupt Source*2	Cause of Interrupt	Interrupt ID (PLIC int_src[])	Interrupt Type*1	Note
Reserved	—	75	—	
Reserved	—	76	—	
Reserved	—	77	—	
GTM (ch0)	OSTM0TINT	78	Edge	
GTM (ch1)	OSTM1TINT	79	Edge	
GTM (ch2)	OSTM2TINT	80	Edge	
WDT (AX45MP)	WDTINT_A0	81	Level	
	PERROUT_A0	82	Level	
Reserved	—	83	—	
Reserved	—	84	—	
Reserved	—	85	—	
Reserved	—	86	—	
Reserved	—	87	—	
Reserved	—	88	—	
Reserved	—	89	—	
Reserved	—	90	—	
Reserved	—	91	—	
Reserved	—	92	—	
Reserved	—	93	—	
Reserved	—	94	—	
Reserved	—	95	—	
Reserved	—	96	—	
Reserved	—	97	—	
Reserved	—	98	—	
Reserved	—	99	—	
Reserved	—	100	—	
Reserved	—	101	—	
Reserved	—	102	—	
Reserved	—	103	—	
Reserved	—	104	—	
Reserved	—	105	—	
Reserved	—	106	—	
Reserved	—	107	—	
Reserved	—	108	—	
Reserved	—	109	—	
Reserved	—	110	—	
Reserved	—	111	—	
Reserved	—	112	—	
Reserved	—	113	—	
Reserved	—	114	—	
Reserved	—	115	—	
GbE (ch0)	pif_int_n_ch0	116	Level	
	int_fil_n_ch0	117	Level	
	int_arp_ns_n_ch0	118	Level	

Table 8.2 Interrupt mapping (4/13)

Interrupt Source*2	Cause of Interrupt	Interrupt ID (PLIC int_src[])	Interrupt Type*1	Note
GbE (ch1)	pif_int_n_ch1	119	Level	
	int_fil_n_ch1	120	Level	
	int_arp_ns_n_ch!	121	Level	
USB2.0 (Host ch0)	U2H0_INT	122	Level	
	U2H0_OHCI_INT	123	Level	
	U2H0_EHCI_INT	124	Level	
	U2H0_WAKEON_INT	125	Level	
	U2H0_OBINT	126	Level	
USB2.0 (Host ch1)	U2H1_INT	127	Level	
	U2H1_OHCI_INT	128	Level	
	U2H1_EHCI_INT	129	Level	
	U2H1_WAKEON_INT	130	Level	
	U2H1_OBINT	131	Level	
USB2.0 (Function)	U2P_IXL_INT	132	Edge	
	U2P_INT_DMA[0]	133	Level	
	U2P_INT_DMA[1]	134	Level	
	U2P_INT_DMAERR	135	Level	
SDHI/eMMC (ch0)	OXMNIRQ0	136	Level	
	OXASIOIRQ0	137	Level	
SDHI/eMMC (ch1)	OXMNIRQ1	138	Level	
	OXASIOIRQ1	139	Level	
DMAC (Secure)	DMAINT0_S	140	Edge	
	DMAINT1_S	141	Edge	
	DMAINT2_S	142	Edge	
	DMAINT3_S	143	Edge	
	DMAINT4_S	144	Edge	
	DMAINT5_S	145	Edge	
	DMAINT6_S	146	Edge	
	DMAINT7_S	147	Edge	
	DMAINT8_S	148	Edge	
	DMAINT9_S	149	Edge	
	DMAINT10_S	150	Edge	
	DMAINT11_S	151	Edge	
	DMAINT12_S	152	Edge	
	DMAINT13_S	153	Edge	
	DMAINT14_S	154	Edge	
	DMAINT15_S	155	Edge	
	DMAERR_S	156	Edge	

Table 8.2 Interrupt mapping (5/13)

Interrupt Source*2	Cause of Interrupt	Interrupt ID (PLIC int_src[])	Interrupt Type*1	Note
DMAC (Non-Secure)	DMAINT0_NS	157	Edge	
	DMAINT1_NS	158	Edge	
	DMAINT2_NS	159	Edge	
	DMAINT3_NS	160	Edge	
	DMAINT4_NS	161	Edge	
	DMAINT5_NS	162	Edge	
	DMAINT6_NS	163	Edge	
	DMAINT7_NS	164	Edge	
	DMAINT8_NS	165	Edge	
	DMAINT9_NS	166	Edge	
	DMAINT10_NS	167	Edge	
	DMAINT11_NS	168	Edge	
	DMAINT12_NS	169	Edge	
	DMAINT13_NS	170	Edge	
	DMAINT14_NS	171	Edge	
DMAINT15_NS	172	Edge		
DMAERR_NS	173	Edge		
Reserved	—	174	—	
Reserved	—	175	—	
Reserved	—	176	—	
Reserved	—	177	—	
Reserved	—	178	—	
Reserved	—	179	—	
Reserved	—	180	—	
Reserved	—	181	—	
Reserved	—	182	—	
Reserved	—	183	—	
Reserved	—	184	—	
Reserved	—	185	—	
Reserved	—	186	—	
Reserved	—	187	—	
Reserved	—	188	—	
Reserved	—	189	—	
Reserved	—	190	—	
Reserved	—	191	—	
Reserved	—	192	—	
Reserved	—	193	—	
Reserved	—	194	—	
Reserved	—	195	—	
Reserved	—	196	—	
Reserved	—	197	—	
Reserved	—	198	—	
Reserved	—	199	—	
Reserved	—	200	—	
Reserved	—	201	—	

Table 8.2 Interrupt mapping (6/13)

Interrupt Source*2	Cause of Interrupt	Interrupt ID (PLIC int_src[])	Interrupt Type*1	Note
MTU3a (ch0)	TGIA0	202	Edge	
	TGIB0	203	Edge	
	TGIC0	204	Edge	
	TGID0	205	Edge	
	TCIV0	206	Edge	
	TGIE0	207	Edge	
	TGIF0	208	Edge	
MTU3a (ch1)	TGIA1	209	Edge	
	TGIB1	210	Edge	
	TCIV1	211	Edge	
	TCIU1	212	Edge	
MTU3a (ch2)	TGIA2	213	Edge	
	TGIB2	214	Edge	
	TCIV2	215	Edge	
	TCIU2	216	Edge	
MTU3a (ch3)	TGIA3	217	Edge	
	TGIB3	218	Edge	
	TGIC3	219	Edge	
	TGID3	220	Edge	
	TCIV3	221	Edge	
MTU3a (ch4)	TGIA4	222	Edge	
	TGIB4	223	Edge	
	TGIC4	224	Edge	
	TGID4	225	Edge	
	TCIV4	226	Edge	
MTU3a (ch5)	TGIU5	227	Edge	
	TGIV5	228	Edge	
	TGIW5	229	Edge	
MTU3a (ch6)	TGIA6	230	Edge	
	TGIB6	231	Edge	
	TGIC6	232	Edge	
	TGID6	233	Edge	
	TCIV6	234	Edge	
MTU3a (ch7)	TGIA7	235	Edge	
	TGIB7	236	Edge	
	TGIC7	237	Edge	
	TGID7	238	Edge	
	TCIV7	239	Edge	
MTU3a (ch8)	TGIA8	240	Edge	
	TGIB8	241	Edge	
	TGIC8	242	Edge	
	TGID8	243	Edge	
	TCIV8	244	Edge	
Reserved	—	245	—	

Table 8.2 Interrupt mapping (7/13)

Interrupt Source*2	Cause of Interrupt	Interrupt ID (PLIC int_src[])	Interrupt Type*1	Note
POE3	OEI1	246	Level	
	OEI2	247	Level	
	OEI3	248	Level	
	OEI4	249	Level	
Reserved	—	250	—	
Reserved	—	251	—	
Reserved	—	252	—	
Reserved	—	253	—	
Reserved	—	254	—	
Reserved	—	255	—	
Reserved	—	256	—	
Reserved	—	257	—	
Reserved	—	258	—	
Reserved	—	259	—	
Reserved	—	260	—	
Reserved	—	261	—	
Reserved	—	262	—	
Reserved	—	263	—	
Reserved	—	264	—	
Reserved	—	265	—	
Reserved	—	266	—	
Reserved	—	267	—	
Reserved	—	268	—	
Reserved	—	269	—	
Reserved	—	270	—	
Reserved	—	271	—	
Reserved	—	272	—	
Reserved	—	273	—	
Reserved	—	274	—	
Reserved	—	275	—	
Reserved	—	276	—	
Reserved	—	277	—	
Reserved	—	278	—	
Reserved	—	279	—	
Reserved	—	280	—	
Reserved	—	281	—	
Reserved	—	282	—	
Reserved	—	283	—	
Reserved	—	284	—	
Reserved	—	285	—	
Reserved	—	286	—	
Reserved	—	287	—	
Reserved	—	288	—	
Reserved	—	289	—	
Reserved	—	290	—	

Table 8.2 Interrupt mapping (8/13)

Interrupt Source*2	Cause of Interrupt	Interrupt ID (PLIC int_src[])	Interrupt Type*1	Note
Reserved	—	291	—	
Reserved	—	292	—	
Reserved	—	293	—	
Reserved	—	294	—	
Reserved	—	295	—	
Reserved	—	296	—	
Reserved	—	297	—	
Reserved	—	298	—	
Reserved	—	299	—	
Reserved	—	300	—	
Reserved	—	301	—	
Reserved	—	302	—	
Reserved	—	303	—	
Reserved	—	304	—	
Reserved	—	305	—	
Reserved	—	306	—	
Reserved	—	307	—	
Reserved	—	308	—	
Reserved	—	309	—	
Reserved	—	310	—	
Reserved	—	311	—	
Reserved	—	312	—	
Reserved	—	313	—	
Reserved	—	314	—	
Reserved	—	315	—	
Reserved	—	316	—	
Reserved	—	317	—	
Reserved	—	318	—	
Reserved	—	319	—	
Reserved	—	320	—	
Reserved	—	321	—	
Reserved	—	322	—	
Reserved	—	323	—	
Reserved	—	324	—	
Reserved	—	325	—	
Reserved	—	326	—	
Reserved	—	327	—	
Reserved	—	328	—	
Reserved	—	329	—	
Reserved	—	330	—	
Reserved	—	331	—	
Reserved	—	332	—	
Reserved	—	333	—	
Reserved	—	334	—	
Reserved	—	335	—	

Table 8.2 Interrupt mapping (9/13)

Interrupt Source*2	Cause of Interrupt	Interrupt ID (PLIC int_src[])	Interrupt Type*1	Note
Reserved	—	336	—	
Reserved	—	337	—	
Reserved	—	338	—	
Reserved	—	339	—	
Reserved	—	340	—	
Reserved	—	341	—	
Reserved	—	342	—	
Reserved	—	343	—	
Reserved	—	344	—	
Reserved	—	345	—	
Reserved	—	346	—	
Reserved	—	347	—	
Reserved	—	348	—	
Reserved	—	349	—	
Reserved	—	350	—	
Reserved	—	351	—	
Reserved	—	352	—	
Reserved	—	353	—	
Reserved	—	354	—	
Reserved	—	355	—	
Reserved	—	356	—	
Reserved	—	357	—	
SSIF (ch0)	INT_ssif_int_req_0	358	Level	
	INT_ssif_dma_rx_0	359	Edge	
	INT_ssif_dma_tx_0	360	Edge	
Reserved	—	361	—	
SSIF (ch1)	INT_ssif_int_req_1	362	Level	
	INT_ssif_dma_rx_1	363	Edge	
	INT_ssif_dma_tx_1	364	Edge	
Reserved	—	365	—	
SSIF (ch2)	INT_ssif_int_req_2	366	Level	
Reserved	—	367	—	
Reserved	—	368	—	
SSIF (ch2)	INT_ssif_dma_rt_2	369	Edge	
SSIF (ch3)	INT_ssif_int_req_3	370	Level	
	INT_ssif_dma_rx_3	371	Edge	
	INT_ssif_dma_tx_3	372	Edge	
Reserved	—	373	—	
Reserved	—	374	—	
	—	375	—	
	—	376	—	
	—	377	—	
	—	378	—	
ADC	INTAD	379	Edge	

Table 8.2 Interrupt mapping (10/13)

Interrupt Source* ²	Cause of Interrupt	Interrupt ID (PLIC int_src[])	Interrupt Type* ¹	Note
I2C (ch0)	INTRIICRI0	380	Edge	
	INTRIICTI0	381	Edge	
	INTRIICTEI0	382	Level	
	INTRIICNAKI0	383	Level	
	INTRIICSPI0	384	Level	
	INTRIICSTI0	385	Level	
	INTRIICALI0	386	Level	
	INTRIICTMOI0	387	Level	
I2C (ch1)	INTRIICRI1	388	Edge	
	INTRIICTI1	389	Edge	
	INTRIICTEI1	390	Level	
	INTRIICNAKI1	391	Level	
	INTRIICSPI1	392	Level	
	INTRIICSTI1	393	Level	
	INTRIICALI1	394	Level	
	INTRIICTMOI1	395	Level	
I2C (ch2)	INTRIICRI2	396	Edge	
	INTRIICTI2	397	Edge	
	INTRIICTEI2	398	Level	
	INTRIICNAKI2	399	Level	
	INTRIICSPI2	400	Level	
	INTRIICSTI2	401	Level	
	INTRIICALI2	402	Level	
	INTRIICTMOI2	403	Level	
I2C (ch3)	INTRIICRI3	404	Edge	
	INTRIICTI3	405	Edge	
	INTRIICTEI3	406	Level	
	INTRIICNAKI3	407	Level	
	INTRIICSPI3	408	Level	
	INTRIICSTI3	409	Level	
	INTRIICALI3	410	Level	
	INTRIICTMOI3	411	Level	
SCIFA (ch0)	ERI0	412	Level	
	BRI0	413	Level	
	RXI0	414	Level	
	TXI0	415	Level	
	TEI0_DRIO	416	Level	
SCIFA (ch1)	ERI1	417	Level	
	BRI1	418	Level	
	RXI1	419	Level	
	TXI1	420	Level	
	TEI1_DR11	421	Level	

Table 8.2 Interrupt mapping (11/13)

Interrupt Source* ²	Cause of Interrupt	Interrupt ID (PLIC int_src[])	Interrupt Type* ¹	Note
SCIFA (ch2)	ERI2	422	Level	
	BRI2	423	Level	
	RXI2	424	Level	
	TXI2	425	Level	
	TEI2_DRI2	426	Level	
SCIFA (ch3)	ERI3	427	Level	
	BRI3	428	Level	
	RXI3	429	Level	
	TXI3	430	Level	
	TEI3_DRI3	431	Level	
SCIFA (ch4)	ERI4	432	Level	
	BRI4	433	Level	
	RXI4	434	Level	
	TXI4	435	Level	
	TEI4_DRI4	436	Level	
SClg (ch0)	ERI0	437	Level	
	RXI0	438	Edge	
	TXI0	439	Edge	
	TEI0	440	Level	
SClg (ch1)	ERI1	441	Level	
	RXI1	442	Edge	
	TXI1	443	Edge	
	TEI1	444	Level	
RSPi (ch0)	SPRI0	445	Level	
	SPTI0	446	Level	
	SPEI0	447	Level	
RSPi (ch1)	SPRI1	448	Level	
	SPTI1	449	Level	
	SPEI1	450	Level	
RSPi (ch2)	SPRI2	451	Level	
	SPTI2	452	Level	
	SPEI2	453	Level	
CANFD	INTRCAN0ERR	454	Level	
	INTRCAN1ERR	455	Level	
	INTRCAN0REC	456	Level	
	INTRCAN1REC	457	Level	
	INTRCANGERR	458	Level	
	INTRCANGRECC	459	Level	
	INTRCAN0TRX	460	Level	
	INTRCAN1TRX	461	Level	

Table 8.2 Interrupt mapping (12/13)

Interrupt Source*2	Cause of Interrupt	Interrupt ID (PLIC int_src[])	Interrupt Type*1	Note
TSIP	WRRDY1	462	Edge	
	WRRDY0	463	Edge	
	WRRDY4	464	Edge	
	RDRDY1	465	Edge	
	RDRDY0	466	Edge	
	ROMOK	467	Edge	
	LONG_PLG	468	Edge	
	PROC_BUSY	469	Edge	
	IRDRDY	470	Edge	
	IWRRDY	471	Edge	
Reserved	—	472	—	
Reserved	—	473	—	
Reserved	—	474	—	
Reserved	—	475	—	
GPIO Interrupt	TINT0	476	Level	
	TINT1	477	Level	
	TINT2	478	Level	
	TINT3	479	Level	
	TINT4	480	Level	
	TINT5	481	Level	
	TINT6	482	Level	
	TINT7	483	Level	
	TINT8	484	Level	
	TINT9	485	Level	
	TINT10	486	Level	
	TINT11	487	Level	
	TINT12	488	Level	
	TINT13	489	Level	
	TINT14	490	Level	
	TINT15	491	Level	
	TINT16	492	Level	
	TINT17	493	Level	
	TINT18	494	Level	
	TINT19	495	Level	
	TINT20	496	Level	
	TINT21	497	Level	
	TINT22	498	Level	
	TINT23	499	Level	
	TINT24	500	Level	
	TINT25	501	Level	
	TINT26	502	Level	
	TINT27	503	Level	
	TINT28	504	Level	
	TINT29	505	Level	
TINT30	506	Level		

Table 8.2 Interrupt mapping (13/13)

Interrupt Source* ²	Cause of Interrupt	Interrupt ID (PLIC int_src[])	Interrupt Type* ¹	Note
GPIO Interrupt	TINT31	507	Level	
AX45MP	l2_err_int	508	Level	
Reserved	—	509	—	
Reserved	—	510	—	
Reserved	—	511	—	

Note 1. The interrupt flow should be changed for interrupt type. Refer to **Section 8.8.4** for details.

Note 2. Refer to the source unit section for the specification of each interrupt source.

Note 3. NMI is not treated as NMI exception.

NMI interrupt setting can be controlled by the registers in IAX45. Refer to **Section 8.7.1** for details.

Note 4. IRQ0-7 interrupt settings can be controlled by the registers in IAX45. Refer to **Section 8.7.2** for details.

Note 5. TINT0-31 interrupt settings can be controlled by the registers in IAX45. Refer to **Section 8.7.3** for details.

Note 6. BUS_ERR_INT is the interrupt integrated multiple interrupts into one in IAX45.

The interrupt settings can be controlled by the registers in IAX45. Refer to **Section 8.7.4.1** for details.

Note 7. Each EC7TIE1, TC7TIE2 and EC7TIOVF is the interrupt integrated multiple interrupts into one in IAX45.

The interrupt settings can be controlled by the registers in IAX45. Refer to **Section 8.7.4.2** for details.

8.3 PLIC Register Configuration

The following tables show PLIC Register List.

- Base Address: H'0_12C0_0000 (AX45MP Address Space)

Table 8.3 PLIC for External Interrupt and Internal Interrupt Register List

Register Name	R/W	Initial Value	Address	Access Size
Feature enable register	R/W	H'0000_0000	H'000000	32
Source 1 priority	R/W	H'0000_0001	H'000004	32
Source 2 priority	R/W	H'0000_0001	H'000008	32
...
Source 543 priority	R/W	H'0000_0001	H'00087C	32
Pending array	R/W	H'0000_0000	H'001000 – H'00107F	32
Trigger type array	RO	Note1	H'001080 – H'0010FF	32
Number of interrupts and targets	RO	H' 0003_021F	H'001100	32
Version and max priority	RO	H'00FF_0001	H'001104	32
Target 0 interrupt enable bits	R/W	H'0000_0000	H'002000 – H'00207F	32
Target 1 interrupt enable bits	R/W	H'0000_0000	H'002080 – H'0020FF	32
Target 2 interrupt enable bits	R/W	H'0000_0000	H'002100 – H'00217F	32
Target 0 priority threshold	R/W	H'0000_0000	H'200000	32
Target 0 claim/complete	R/W	H'0000_0000	H'200004	32
Target 0 preempted priority stack	R/W	H'0000_0000	H'200400	32
Target 1 priority threshold	R/W	H'0000_0000	H'201000	32
Target 1 claim/complete	R/W	H'0000_0000	H'201004	32
Target 1 preempted priority stack	R/W	H'0000_0000	H'201400	32
Target 2 priority threshold	R/W	H'0000_0000	H'202000	32
Target 2 claim/complete	R/W	H'0000_0000	H'202004	32
Target 2 preempted priority stack	R/W	H'0000_0000	H'202400	32

- Base Address: H'0_1300_0000 (AX45MP Address Space)

Table 8.4 PLIC for Software Interrupt Register List

Register Name	R/W	Initial Value	Address	Access Size
Feature enable register	R/W	H'0000_0000	H'000000	32
Source 1 priority	R/W	H'0000_0001	H'000004	32
Source 2 priority	R/W	H'0000_0001	H'000008	32
...
Source 31 priority	R/W	H'0000_0001	H'00007C	32
Pending array	R/W	H'0000_0000	H'001000	32
Trigger type array	RO	H'0000_0000	H'001080	32
Number of interrupts and targets	RO	H'0001_001F	H'001100	32
Version and max priority	RO	H'001F_0001	H'001104	32
Target 0 interrupt enable bits	R/W	H'0000_0000	H'002000	32
Target 0 priority threshold	R/W	H'0000_0000	H'200000	32
Target 0 claim/complete	R/W	H'0000_0000	H'200004	32
Target 0 preempted priority stack	R/W	H'0000_0000	H'200400	32

8.4 PLIC Register Descriptions

Refer to AndesCore™ AX45MP-1C Processor Reference Manual for detail.

8.5 IAX45 Register Configuration

Base Address: H'0_110A_0000 (AX45MP Address Space)

The following table shows IAX45 Register list.
Prohibit to write undefined area.

Table 8.5 IAX45 Register List

Register Name	Abbreviation	R/W	Initial Value	Address	Access Size
NMI Status Control Register	NSCR	R/W	H'0000_0000	H'0000	32
NMI Interrupt Type Selection Register	NITSR	R/W	H'0000_0000	H'0004	32
IRQ Status Control Register	ISCR	R/W	H'0000_0000	H'0010	32
IRQ Interrupt Type Selection Register	IITSR	R/W	H'0000_0000	H'0014	32
TINT Status Control Register	TSCR	R/W	H'0000_0000	H'0020	32
TINT Interrupt Type Selection Register0	TITSR0	R/W	H'0000_0000	H'0024	32
TINT Interrupt Type Selection Register1	TITSR1	R/W	H'0000_0000	H'0028	32
TINT Source Selection Register0	TSSR0	R/W	H'0000_0000	H'0030	32
TINT Source Selection Register1	TSSR1	R/W	H'0000_0000	H'0034	32
TINT Source Selection Register2	TSSR2	R/W	H'0000_0000	H'0038	32
TINT Source Selection Register3	TSSR3	R/W	H'0000_0000	H'003C	32
TINT Source Selection Register4	TSSR4	R/W	H'0000_0000	H'0040	32
TINT Source Selection Register5	TSSR5	R/W	H'0000_0000	H'0044	32
TINT Source Selection Register6	TSSR6	R/W	H'0000_0000	H'0048	32
TINT Source Selection Register7	TSSR7	R/W	H'0000_0000	H'004C	32
Bus Error Interrupt Status Control Register0	BEISR0	R/W	H'0000_0000	H'0050	32
Bus Error Interrupt Status Control Register1	BEISR1	R/W	H'0000_0000	H'0054	32
ECCRAM Error Interrupt Status Control Register0	EREISR0	R/W	H'0000_0000	H'0060	32
ECCRAM Error Interrupt Status Control Register1	EREISR1	R/W	H'0000_0000	H'0064	32
NMI Interrupt Mask Control Register	NMSK	R/W	H'0000_0001	H'1_0000	32
IRQ Interrupt Mask Control Register	IMSK	R/W	H'0000_00FF	H'1_0010	32
TINT Interrupt Mask Control Register	TMSK	R/W	H'FFFF_FFFF	H'1_0020	32

8.6 IAX45 Register Descriptions

8.6.1 NMI Status Control Register (NSCR)

This register shows NMI status.

Bit	31	30	29	28	27	26	25	24	23	22	21	20	19	18	17	16
	—	—	—	—	—	—	—	—	—	—	—	—	—	—	—	NSMON
Initial Value	0	0	0	0	0	0	0	0	0	0	0	0	0	0	0	0
R/W	R	R	R	R	R	R	R	R	R	R	R	R	R	R	R	R
Bit	15	14	13	12	11	10	9	8	7	6	5	4	3	2	1	0
	—	—	—	—	—	—	—	—	—	—	—	—	—	—	—	NSTAT
Initial Value	0	0	0	0	0	0	0	0	0	0	0	0	0	0	0	0
R/W	R	R	R	R	R	R	R	R	R	R	R	R	R	R	R	R/W

Bit	Bit Name	Initial Value	R/W	Description
31 to 17	—	All 0	R	Reserved Whenever it is read, 0 is read. The written value will be ignored.
16	NSMON	0	R	This bit indicates NMI pin signal level. [Read operation] 0: NMI pin is Low-level. 1: NMI pin is High-level. [Write operation] Invalid to write.
15 to 1	—	All 0	R	Reserved Whenever it is read, 0 is read. The written value will be ignored.
0	NSTAT	0	R/W	This bit indicates NMI interrupt status. NMI interrupt status can be cleared writing 0 in case NSTAT is 1. [Read operation] 0: NMI interrupt is not detected. 1: NMI interrupt is detected. [Write operation] • In case NSTAT is 1 0: NMI interrupt status is cleared. 1: Invalid to write. • In case NSTAT is 0 Invalid to write.

8.6.2 NMI Interrupt Type Selection Register (NITSR)

This register selects NMI detecting method.

Bit	31	30	29	28	27	26	25	24	23	22	21	20	19	18	17	16
	—	—	—	—	—	—	—	—	—	—	—	—	—	—	—	—
Initial Value	0	0	0	0	0	0	0	0	0	0	0	0	0	0	0	0
R/W	R	R	R	R	R	R	R	R	R	R	R	R	R	R	R	R
Bit	15	14	13	12	11	10	9	8	7	6	5	4	3	2	1	0
	—	—	—	—	—	—	—	—	—	—	—	—	—	—	—	NTSEL
Initial Value	0	0	0	0	0	0	0	0	0	0	0	0	0	0	0	0
R/W	R	R	R	R	R	R	R	R	R	R	R	R	R	R	R	R/W

Bit	Bit Name	Initial Value	R/W	Description
31 to 1	—	All 0	R	Reserved Whenever it is read, 0 is read. The written value will be ignored.
0	NTSEL	0	R/W	This bit is used to select NMI interrupt detection method. 0: Falling-edge detection. 1: Rising-edge detection.

8.6.3 IRQ Status Control Register (ISCR)

This register shows IRQ status.

Bit	31	30	29	28	27	26	25	24	23	22	21	20	19	18	17	16
	—	—	—	—	—	—	—	—	—	—	—	—	—	—	—	—
Initial Value	0	0	0	0	0	0	0	0	0	0	0	0	0	0	0	0
R/W	R	R	R	R	R	R	R	R	R	R	R	R	R	R	R	R
Bit	15	14	13	12	11	10	9	8	7	6	5	4	3	2	1	0
	—	—	—	—	—	—	—	—	ISTAT7	ISTAT6	ISTAT5	ISTAT4	ISTAT3	ISTAT2	ISTAT1	ISTAT0
Initial Value	0	0	0	0	0	0	0	0	0	0	0	0	0	0	0	0
R/W	R	R	R	R	R	R	R	R	R/W	R/W	R/W	R/W	R/W	R/W	R/W	R/W

Bit	Bit Name	Initial Value	R/W	Description
31 to 8	—	All 0	R	Reserved Whenever it is read, 0 is read. The written value will be ignored.
n	ISTATn	0	R/W	This bit indicates IRQn interrupt status. When the interrupt detection method is set to an edge type detection in IITSR, IRQn interrupt status can be cleared writing 0 in case ISTATn is 1. [Read operation] 0: IRQn interrupt is not detected. 1: IRQn interrupt is detected. [Write operation] When “Falling-edge detection”, “Rising-edge detection” or “Falling/Rising-edge detection” is set in ITSR.: <ul style="list-style-type: none"> In case ISTAT is 1 <ul style="list-style-type: none"> 0: IRQn interrupt detection status is cleared. 1: Invalid to write. In case ISTAT is 0 <ul style="list-style-type: none"> Invalid to write. When “Low-level detection” is set in IITSR.: Invalid to write.

Note: n = 7 to 0

8.6.4 IRQ Interrupt Type Selection Register (IITSR)

This register selects IRQ detecting method.

Bit	31	30	29	28	27	26	25	24	23	22	21	20	19	18	17	16
	—	—	—	—	—	—	—	—	—	—	—	—	—	—	—	—
Initial Value	0	0	0	0	0	0	0	0	0	0	0	0	0	0	0	0
R/W	R	R	R	R	R	R	R	R	R	R	R	R	R	R	R	R
Bit	15	14	13	12	11	10	9	8	7	6	5	4	3	2	1	0
	IITSEL7		IITSEL6		IITSEL5		IITSEL4		IITSEL3		IITSEL2		IITSEL1		IITSEL0	
Initial Value	0	0	0	0	0	0	0	0	0	0	0	0	0	0	0	0
R/W	R/W	R/W	R/W	R/W	R/W	R/W	R/W	R/W	R/W	R/W	R/W	R/W	R/W	R/W	R/W	R/W

Bit	Bit Name	Initial Value	R/W	Description
31 to 16	—	All 0	R	Reserved Whenever it is read, 0 is read. The written value will be ignored.
2n+1 to 2n	IITSEL	All 0	R/W	This bit is used to select IRQn interrupt detection method. 00: Low-level detection. 01: Falling-edge detection. 10: Rising-edge detection. 11: Falling/Rising-edge detection.

Note: n = 7 to 0

8.6.5 TINT Status Control Register (TSCR)

This register shows TINT status.

Bit	31	30	29	28	27	26	25	24	23	22	21	20	19	18	17	16
	TSTAT3 1	TSTAT3 0	TSTAT2 9	TSTAT2 8	TSTAT2 7	TSTAT2 6	TSTAT2 5	TSTAT2 4	TSTAT2 3	TSTAT2 2	TSTAT2 1	TSTAT2 0	TSTAT1 9	TSTAT1 8	TSTAT1 7	TSTAT1 6
Initial Value	0	0	0	0	0	0	0	0	0	0	0	0	0	0	0	0
R/W	R/W	R/W	R/W	R/W	R/W	R/W	R/W	R/W	R/W	R/W	R/W	R/W	R/W	R/W	R/W	R/W
Bit	15	14	13	12	11	10	9	8	7	6	5	4	3	2	1	0
	TSTAT1 5	TSTAT1 4	TSTAT1 3	TSTAT1 2	TSTAT1 1	TSTAT1 0	TSTAT9	TSTAT8	TSTAT7	TSTAT6	TSTAT5	TSTAT4	TSTAT3	TSTAT2	TSTAT1	TSTAT0
Initial Value	0	0	0	0	0	0	0	0	0	0	0	0	0	0	0	0
R/W	R/W	R/W	R/W	R/W	R/W	R/W	R/W	R/W	R/W	R/W	R/W	R/W	R/W	R/W	R/W	R/W

Bit	Bit Name	Initial Value	R/W	Description
n	TSTATn	All 0	R/W	<p>This bit indicates TINTn interrupt status.</p> <p>When the interrupt detection method is set to edge type detection in TITSR0/1, TINTn interrupt status can be cleared writing 0 in case TSTATn is 1.</p> <p>[Read operation]</p> <ul style="list-style-type: none"> 0: TINTn interrupt is not detected. 1: TINTn interrupt is detected. <p>[Write operation]</p> <p>When "Rising-edge detection" or "Falling-edge detection" is set in TITSR0/1.:</p> <ul style="list-style-type: none"> • In case TSTAT is 1 <ul style="list-style-type: none"> 0: TINTn interrupt detection status is cleared. 1: Invalid to write. • In case TSTAT is 0 <ul style="list-style-type: none"> Invalid to write. <p>When "Low-level detection" or "High-Level detection" is set in TITSR0/1.:</p> <ul style="list-style-type: none"> Invalid to write.

Note: n = 31 to 0

8.6.6 TINT Interrupt Type Selection Register0 (TITSR0)

This register selects detecting method of TINT15 to TINT0.

Bit	31	30	29	28	27	26	25	24	23	22	21	20	19	18	17	16
	TITSEL15		TITSEL14		TITSEL13		TITSEL12		TITSEL11		TITSEL10		TITSEL9		TITSEL8	
Initial Value	0	0	0	0	0	0	0	0	0	0	0	0	0	0	0	0
R/W	R/W	R/W	R/W	R/W	R/W	R/W	R/W	R/W	R/W	R/W	R/W	R/W	R/W	R/W	R/W	R/W
Bit	15	14	13	12	11	10	9	8	7	6	5	4	3	2	1	0
	TITSEL7		TITSEL6		TITSEL5		TITSEL4		TITSEL3		TITSEL2		TITSEL1		TITSEL0	
Initial Value	0	0	0	0	0	0	0	0	0	0	0	0	0	0	0	0
R/W	R/W	R/W	R/W	R/W	R/W	R/W	R/W	R/W	R/W	R/W	R/W	R/W	R/W	R/W	R/W	R/W

Bit	Bit Name	Initial Value	R/W	Description
2n+1 to 2n	TITSELn	All 0	R/W	This bit is used to select TINTn interrupt detection method. 00: Rising-edge detection. 01: Falling-edge detection. 10: High-level detection. 11: Low-level detection.

Note: n = 15 to 0

8.6.7 TINT Interrupt Type Selection Register1 (TITSR1)

This register selects detecting method of TINT31 to TINT16.

Bit	31	30	29	28	27	26	25	24	23	22	21	20	19	18	17	16
	TITSEL31		TITSEL30		TITSEL29		TITSEL28		TITSEL27		TITSEL26		TITSEL25		TITSEL24	
Initial Value	0	0	0	0	0	0	0	0	0	0	0	0	0	0	0	0
R/W	R/W	R/W	R/W	R/W	R/W	R/W	R/W	R/W	R/W	R/W	R/W	R/W	R/W	R/W	R/W	R/W
Bit	15	14	13	12	11	10	9	8	7	6	5	4	3	2	1	0
	TITSEL23		TITSEL22		TITSEL21		TITSEL20		TITSEL19		TITSEL18		TITSEL17		TITSEL16	
Initial Value	0	0	0	0	0	0	0	0	0	0	0	0	0	0	0	0
R/W	R/W	R/W	R/W	R/W	R/W	R/W	R/W	R/W	R/W	R/W	R/W	R/W	R/W	R/W	R/W	R/W

Bit	Bit Name	Initial Value	R/W	Description
2n+1 to 2n	TITSELn+16	All 0	R/W	This bit is used to select TINTn+16 interrupt detection method. 00: Rising-edge detection. 01: Falling-edge detection. 10: High-level detection. 11: Low-level detection.

Note: n = 15 to 0

8.6.8 TINT Source Selection Register0 (TSSR0)

This register selects the interrupt source of TINT3 to TINT0.

Refer to **Section 8.7.3** about mapping GPIOINT onto GPIO pin.

Bit	31	30	29	28	27	26	25	24	23	22	21	20	19	18	17	16		
	TIEN3		TSSEL3								TIEN2		TSSEL2					
Initial Value	0	0	0	0	0	0	0	0	0	0	0	0	0	0	0	0		
R/W	R/W	R/W	R/W	R/W	R/W	R/W	R/W	R/W	R/W	R/W	R/W	R/W	R/W	R/W	R/W	R/W		
Bit	15	14	13	12	11	10	9	8	7	6	5	4	3	2	1	0		
	TIEN1		TSSEL1								TIEN0		TSSEL0					
Initial Value	0	0	0	0	0	0	0	0	0	0	0	0	0	0	0	0		
R/W	R/W	R/W	R/W	R/W	R/W	R/W	R/W	R/W	R/W	R/W	R/W	R/W	R/W	R/W	R/W	R/W		

Bit	Bit Name	Initial Value	R/W	Description
8n+7	TIENn	0	R/W	This bit enables TINTn. 1: Enable. 0: Invalid.
8n+6 to 8n	TSSELn	All 0	R/W	This bit selects a source of TINTn. 0000000: TINTn = GPIOINT0 0000001: TINTn = GPIOINT1 ~ 1010001: TINTn = GPIOINT81 1010010: Cannot be set. ~ 1111011: Cannot be set. 1111100: Cannot be set. 1111101: Cannot be set. 1111110: Cannot be set. 1111111: Cannot be set.

Assign different sources to TINT0-31.

Note: n = 3 to 0

8.6.9 TINT Source Selection Register1 (TSSR1)

This register selects the interrupt source of TINT7 to TINT4.

Refer to **Section 8.7.3** about mapping GPIOINT onto GPIO pin.

Bit	31	30	29	28	27	26	25	24	23	22	21	20	19	18	17	16		
	TIEN7	TSSEL7								TIEN6	TSSEL6							
Initial Value	0	0	0	0	0	0	0	0	0	0	0	0	0	0	0	0		
R/W	R/W	R/W	R/W	R/W	R/W	R/W	R/W	R/W	R/W	R/W	R/W	R/W	R/W	R/W	R/W	R/W		
Bit	15	14	13	12	11	10	9	8	7	6	5	4	3	2	1	0		
	TIEN5	TSSEL5								TIEN4	TSSEL4							
Initial Value	0	0	0	0	0	0	0	0	0	0	0	0	0	0	0	0		
R/W	R/W	R/W	R/W	R/W	R/W	R/W	R/W	R/W	R/W	R/W	R/W	R/W	R/W	R/W	R/W	R/W		

Bit	Bit Name	Initial Value	R/W	Description
8(n-4)+7	TIENn	0	R/W	This bit enables TINTn. 1: Enable. 0: Invalid.
8(n-4)+6 to 8(n-4)	TSSELn	All 0	R/W	This bit selects a source of TINTn. 0000000: TINTn = GPIOINT0 0000001: TINTn = GPIOINT1 ~ 1010001: TINTn = GPIOINT81 1010010: Cannot be set. ~ 1111011: Cannot be set. 1111100: Cannot be set. 1111101: Cannot be set. 1111110: Cannot be set. 1111111: Cannot be set.

Assign different sources to TINT0-31.

Note: n = 7 to 4

8.6.10 TINT Source Selection Register2 (TSSR2)

This register selects the interrupt source of TINT11 to TINT8.

Refer to **Section 8.7.3** about mapping GPIOINT onto GPIO pin.

Bit	31	30	29	28	27	26	25	24	23	22	21	20	19	18	17	16		
	TIEN11	TSSEL11								TIEN10	TSSEL10							
Initial Value	0	0	0	0	0	0	0	0	0	0	0	0	0	0	0	0		
R/W	R/W	R/W	R/W	R/W	R/W	R/W	R/W	R/W	R/W	R/W	R/W	R/W	R/W	R/W	R/W	R/W		
Bit	15	14	13	12	11	10	9	8	7	6	5	4	3	2	1	0		
	TIEN9	TSSEL9								TIEN8	TSSEL8							
Initial Value	0	0	0	0	0	0	0	0	0	0	0	0	0	0	0	0		
R/W	R/W	R/W	R/W	R/W	R/W	R/W	R/W	R/W	R/W	R/W	R/W	R/W	R/W	R/W	R/W	R/W		

Bit	Bit Name	Initial Value	R/W	Description
8(n-8)+7	TIENn	0	R/W	This bit enables TINTn. 1: Enable. 0: Invalid.
8(n-8)+6 to 8(n-8)	TSSELn	All 0	R/W	This bit selects a source of TINTn. 0000000: TINTn = GPIOINT0 0000001: TINTn = GPIOINT1 ~ 1010001: TINTn = GPIOINT81 1010010: Cannot be set. ~ 1111011: Cannot be set. 1111100: Cannot be set. 1111101: Cannot be set. 1111110: Cannot be set. 1111111: Cannot be set.

Assign different sources to TINT0-31.

Note: n = 11 to 8

8.6.11 TINT Source Selection Register3 (TSSR3)

This register selects the interrupt source of TINT15 to TINT12.

Refer to **Section 8.7.3** about mapping GPIOINT onto GPIO pin.

Bit	31	30	29	28	27	26	25	24	23	22	21	20	19	18	17	16		
	TIEN15		TSSEL15								TIEN14		TSSEL14					
Initial Value	0	0	0	0	0	0	0	0	0	0	0	0	0	0	0	0		
R/W	R/W	R/W	R/W	R/W	R/W	R/W	R/W	R/W	R/W	R/W	R/W	R/W	R/W	R/W	R/W	R/W		
Bit	15	14	13	12	11	10	9	8	7	6	5	4	3	2	1	0		
	TIEN13		TSSEL13						TIEN12		TSSEL12							
Initial Value	0	0	0	0	0	0	0	0	0	0	0	0	0	0	0	0		
R/W	R/W	R/W	R/W	R/W	R/W	R/W	R/W	R/W	R/W	R/W	R/W	R/W	R/W	R/W	R/W	R/W		

Bit	Bit Name	Initial Value	R/W	Description
8(n-12)+7	TIENn	0	R/W	This bit enables TINTn. 1: Enable. 0: Invalid.
8(n-12)+6 to 8(n-12)	TSSELn	All 0	R/W	This bit selects a source of TINTn. 0000000: TINTn = GPIOINT0 0000001: TINTn = GPIOINT1 ~ 1010001: TINTn = GPIOINT81 1010010: Cannot be set. ~ 1111011: Cannot be set. 1111100: Cannot be set. 1111101: Cannot be set. 1111110: Cannot be set. 1111111: Cannot be set.

Assign different sources to TINT0-31.

Note: n = 15 to 12

8.6.12 TINT Source Selection Register4 (TSSR4)

This register selects the interrupt source of TINT19 to TINT16.

Refer to **Section 8.7.3** about mapping GPIOINT onto GPIO pin.

Bit	31	30	29	28	27	26	25	24	23	22	21	20	19	18	17	16		
	TIEN19		TSSEL19								TIEN18		TSSEL18					
Initial Value	0	0	0	0	0	0	0	0	0	0	0	0	0	0	0	0		
R/W	R/W	R/W	R/W	R/W	R/W	R/W	R/W	R/W	R/W	R/W	R/W	R/W	R/W	R/W	R/W	R/W		
Bit	15	14	13	12	11	10	9	8	7	6	5	4	3	2	1	0		
	TIEN17		TSSEL17								TIEN16		TSSEL16					
Initial Value	0	0	0	0	0	0	0	0	0	0	0	0	0	0	0	0		
R/W	R/W	R/W	R/W	R/W	R/W	R/W	R/W	R/W	R/W	R/W	R/W	R/W	R/W	R/W	R/W	R/W		

Bit	Bit Name	Initial Value	R/W	Description
8(n-16)+7	TIENn	0	R/W	This bit enables TINTn. 1: Enable. 0: Invalid.
8(n-16)+6 to 8(n-16)	TSSELn	All 0	R/W	This bit selects a source of TINTn. 0000000: TINTn = GPIOINT0 0000001: TINTn = GPIOINT1 ~ 1010001: TINTn = GPIOINT81 1010010: Cannot be set. ~ 1111011: Cannot be set. 1111100: Cannot be set. 1111101: Cannot be set. 1111110: Cannot be set. 1111111: Cannot be set.

Assign different sources to TINT0-31.

Note: n = 19 to 16

8.6.13 TINT Source Selection Register5 (TSSR5)

This register selects the interrupt source of TINT23 to TINT20.

Refer to **Section 8.7.3** about mapping GPIOINT onto GPIO pin.

Bit	31	30	29	28	27	26	25	24	23	22	21	20	19	18	17	16		
	TIEN23		TSSEL23								TIEN22		TSSEL22					
Initial Value	0	0	0	0	0	0	0	0	0	0	0	0	0	0	0	0		
R/W	R/W	R/W	R/W	R/W	R/W	R/W	R/W	R/W	R/W	R/W	R/W	R/W	R/W	R/W	R/W	R/W		
Bit	15	14	13	12	11	10	9	8	7	6	5	4	3	2	1	0		
	TIEN21		TSSEL21								TIEN20		TSSEL20					
Initial Value	0	0	0	0	0	0	0	0	0	0	0	0	0	0	0	0		
R/W	R/W	R/W	R/W	R/W	R/W	R/W	R/W	R/W	R/W	R/W	R/W	R/W	R/W	R/W	R/W	R/W		

Bit	Bit Name	Initial Value	R/W	Description
8(n-20)+7	TIENn	0	R/W	This bit enables TINTn. 1: Enable. 0: Invalid.
8(n-20)+6 to 8(n-20)	TSSELn	All 0	R/W	This bit selects a source of TINTn. 0000000: TINTn = GPIOINT0 0000001: TINTn = GPIOINT1 ~ 1010001: TINTn = GPIOINT81 1010010: Cannot be set. ~ 1111011: Cannot be set. 1111100: Cannot be set. 1111101: Cannot be set. 1111110: Cannot be set. 1111111: Cannot be set.

Assign different sources to TINT0-31.

Note: n = 23 to 20

8.6.14 TINT Source Selection Register6 (TSSR6)

This register selects the interrupt source of TINT27 to TINT24.

Refer to **Section 8.7.3** about mapping GPIOINT onto GPIO pin.

Bit	31	30	29	28	27	26	25	24	23	22	21	20	19	18	17	16		
	TIEN27	TSSEL27								TIEN26	TSSEL26							
Initial Value	0	0	0	0	0	0	0	0	0	0	0	0	0	0	0	0		
R/W	R/W	R/W	R/W	R/W	R/W	R/W	R/W	R/W	R/W	R/W	R/W	R/W	R/W	R/W	R/W	R/W		
Bit	15	14	13	12	11	10	9	8	7	6	5	4	3	2	1	0		
	TIEN25	TSSEL25								TIEN24	TSSEL24							
Initial Value	0	0	0	0	0	0	0	0	0	0	0	0	0	0	0	0		
R/W	R/W	R/W	R/W	R/W	R/W	R/W	R/W	R/W	R/W	R/W	R/W	R/W	R/W	R/W	R/W	R/W		

Bit	Bit Name	Initial Value	R/W	Description
8(n-24)+7	TIENn	0	R/W	This bit enables TINTn. 1: Enable. 0: Invalid.
8(n-24)+6 to 8(n-24)	TSSELn	All 0	R/W	This bit selects a source of TINTn. 0000000: TINTn = GPIOINT0 0000001: TINTn = GPIOINT1 ~ 1010001: TINTn = GPIOINT81 1010010: Cannot be set. ~ 1111011: Cannot be set. 1111100: Cannot be set. 1111101: Cannot be set. 1111110: Cannot be set. 1111111: Cannot be set.

Assign different sources to TINT0-31.

Note: n = 27 to 24

8.6.15 TINT Source Selection Register7 (TSSR7)

This register selects the interrupt source of TINT31 to TINT28.

Refer to **Section 8.7.3** about mapping GPIOINT onto GPIO pin.

Bit	31	30	29	28	27	26	25	24	23	22	21	20	19	18	17	16		
	TIEN31	TSSEL31								TIEN30	TSSEL30							
Initial Value	0	0	0	0	0	0	0	0	0	0	0	0	0	0	0	0		
R/W	R/W	R/W	R/W	R/W	R/W	R/W	R/W	R/W	R/W	R/W	R/W	R/W	R/W	R/W	R/W	R/W		
Bit	15	14	13	12	11	10	9	8	7	6	5	4	3	2	1	0		
	TIEN29	TSSEL29								TIEN28	TSSEL28							
Initial Value	0	0	0	0	0	0	0	0	0	0	0	0	0	0	0	0		
R/W	R/W	R/W	R/W	R/W	R/W	R/W	R/W	R/W	R/W	R/W	R/W	R/W	R/W	R/W	R/W	R/W		

Bit	Bit Name	Initial Value	R/W	Description
8(n-28)+7	TIENn	0	R/W	This bit enables TINTn. 1: Enable. 0: Invalid.
8(n-28)+6 to 8(n-28)	TSSELn	All 0	R/W	This bit selects a source of TINTn. 0000000: TINTn = GPIOINT0 0000001: TINTn = GPIOINT1 ~ 1010001: TINTn = GPIOINT81 1010010: Cannot be set. ~ 1111011: Cannot be set. 1111100: Cannot be set. 1111101: Cannot be set. 1111110: Cannot be set. 1111111: Cannot be set.

Assign different sources to TINT0-31.

Note: n = 31 to 28

8.6.16 Bus Error Interrupt Status Control Register0 (BEISR0)

This register shows Bus error status.

Refer to LSI Internal Bus section and **Section 8.7.4.1** for bus error interrupt cause.

Bit	31	30	29	28	27	26	25	24	23	22	21	20	19	18	17	16
	BESTAT31	BESTAT30	BESTAT29	BESTAT28	BESTAT27	BESTAT26	BESTAT25	BESTAT24	BESTAT23	BESTAT22	BESTAT21	BESTAT20	BESTAT19	BESTAT18	BESTAT17	BESTAT16
Initial Value	0	0	0	0	0	0	0	0	0	0	0	0	0	0	0	0
R/W	R/W	R/W	R/W	R/W	R/W	R/W	R/W	R/W	R/W	R/W	R/W	R/W	R/W	R/W	R/W	R/W

Bit	15	14	13	12	11	10	9	8	7	6	5	4	3	2	1	0
	BESTAT15	BESTAT14	BESTAT13	TSTAT12	BESTAT11	BESTAT10	BESTAT9	BESTAT8	BESTAT7	BESTAT6	BESTAT5	BESTAT4	BESTAT3	BESTAT2	BESTAT1	BESTAT0
Initial Value	0	0	0	0	0	0	0	0	0	0	0	0	0	0	0	0
R/W	R/W	R/W	R/W	R/W	R/W	R/W	R/W	R/W	R/W	R/W	R/W	R/W	R/W	R/W	R/W	R/W

Bit	Bit Name	Initial Value	R/W	Description
n	BESTATn	All 0	R/W	<p>This bit indicates BUSERR_INTn interrupt status. BUSERR_INTn interrupt status can be cleared writing 0 in case BESTAT is 1.</p> <p>[Read operation] 0: BUSERR_INTn is not detected. 1: BUSERR_INTn is detected.</p> <p>[Write operation] <ul style="list-style-type: none"> In case BESTATn is 1 0: BUSERR_INTn interrupt status is cleared. 1: Invalid to write. In case BESTATn is 0 Invalid to write. </p>

Note: n = 31 to 0

8.6.17 Bus Error Interrupt Status Control Register1 (BEISR1)

This register shows Bus error status.

Refer to LSI Internal Bus section and **Section 8.7.4.1** for bus error interrupt cause.

Bit	31	30	29	28	27	26	25	24	23	22	21	20	19	18	17	16
	—	—	—	—	—	—	—	—	—	—	—	—	—	—	—	—
Initial Value	0	0	0	0	0	0	0	0	0	0	0	0	0	0	0	0
R/W	R	R	R	R	R	R	R	R	R	R	R	R	R	R	R	R
Bit	15	14	13	12	11	10	9	8	7	6	5	4	3	2	1	0
	—	—	—	BESTA T44	BESTA T43	BESTA T42	BESTA T41	BESTA T40	BESTA T39	BESTA T38	BESTA T37	BESTA T36	BESTA T35	BESTA T34	BESTA T33	BESTA T32
Initial Value	0	0	0	0	0	0	0	0	0	0	0	0	0	0	0	0
R/W	R	R	R	R/W	R/W	R/W	R/W	R/W	R/W	R/W	R/W	R/W	R/W	R/W	R/W	R/W

Bit	Bit Name	Initial Value	R/W	Description
31 to 13	—	All 0	R	Reserved Whenever it is read, 0 is read. The written value will be ignored.
n-32	BESTATn	All 0	R/W	This bit indicates BUSERR_INTn interrupt status. BUSERR_INTn interrupt status can be cleared writing 0 in case BESTAT is 1. [Read operation] 0: BUSERR_INTn is not detected. 1: BUSERR_INTn is detected. [Write operation] • In case BESTATn is 1 0: BUSERR_INTn interrupt status is cleared. 1: Invalid to write. • In case BESTATn is 0 Invalid to write.

Note: n = 44 to 32

8.6.18 ECCRAM Error Interrupt Status Control Register0 (EREISR0)

This register shows ECC Error status of ECCRAM0.

Refer to **Section 8.7.4.2** for ECCRAM error interrupt cause.

Bit	31	30	29	28	27	26	25	24	23	22	21	20	19	18	17	16
	—	—	—	—	—	—	—	—	OFSTA T7	OFSTA T6	OFSTA T5	OFSTA T4	OFSTA T3	OFSTA T2	OFSTA T1	OFSTA T0
Initial Value	0	0	0	0	0	0	0	0	0	0	0	0	0	0	0	0
R/W	R	R	R	R	R	R	R	R	R/W	R/W	R/W	R/W	R/W	R/W	R/W	R/W
Bit	15	14	13	12	11	10	9	8	7	6	5	4	3	2	1	0
	E2STAT 7	E2STAT 6	E2STAT 5	E2STAT 4	E2STAT 3	E2STAT 2	E2STAT 1	E2STAT 0	E1STAT 7	E1STAT 6	E1STAT 5	E1STAT 4	E1STAT 3	E1STAT 2	E1STAT 1	E1STAT 0
Initial Value	0	0	0	0	0	0	0	0	0	0	0	0	0	0	0	0
R/W	R/W	R/W	R/W	R/W	R/W	R/W	R/W	R/W	R/W	R/W	R/W	R/W	R/W	R/W	R/W	R/W

Bit	Bit Name	Initial Value	R/W	Description
31 to 24	—	All 0	R	Reserved Whenever it is read, 0 is read. The written value will be ignored.
23 to 16	OFSTATn	All 0	R/W	This bit indicates ECCRAM0_OFn interrupt status. ECCRAM0_OFn interrupt status can be cleared writing 0 in case OFSTATn is 1. [Read operation] 0: ECCRAM0_OFn is not detected. 1: ECCRAM0_OFn is detected. [Write operation] • In case OFSTATn is 1 0: ECCRAM0_OFn interrupt status is cleared. 1: Invalid to write. • In case OFSTATn is 0 Invalid to write.
15 to 8	E2STATn	All 0	R/W	This bit indicates ECCRAM0_2En interrupt status. ECCRAM0_2En interrupt status can be cleared writing 0 in case E2STATn is 1. [Read operation] 0: ECCRAM0_2En is not detected. 1: ECCRAM0_2En is detected. Write operation: • In case E2STATn is 1 0: ECCRAM0_2En interrupt status is cleared. 1: Invalid to write. • In case E2STATn is 0 Invalid to write.

Bit	Bit Name	Initial Value	R/W	Description
7 to 0	E1STATn	All 0	R/W	<p>This bit indicates ECCRAM0_1En interrupt status. ECCRAM0_1En interrupt status can be cleared writing 0 in case E1STATn is 1.</p> <p>[Read operation] 0: ECCRAM0_1En is not detected. 1: ECCRAM0_1En is detected.</p> <p>[Write operation] <ul style="list-style-type: none"> • In case E1STATn is 1 <ul style="list-style-type: none"> 0: ECCRAM0_1En interrupt status is cleared. 1: Invalid to write. • In case E1STATn is 0 <ul style="list-style-type: none"> Invalid to write. </p>

Note: n = 7 to 0

8.6.19 ECCRAM Error Interrupt Status Control Register1 (EREISR1)

This register shows ECC Error status of ECCRAM1.

Refer to **Section 8.7.4.2** for ECCRAM error interrupt cause.

Bit	31	30	29	28	27	26	25	24	23	22	21	20	19	18	17	16
	—	—	—	—	—	—	—	—	OFSTA T7	OFSTA T6	OFSTA T5	OFSTA T4	OFSTA T3	OFSTA T2	OFSTA T1	OFSTA T0
Initial Value	0	0	0	0	0	0	0	0	0	0	0	0	0	0	0	0
R/W	R	R	R	R	R	R	R	R	R/W	R/W	R/W	R/W	R/W	R/W	R/W	R/W
Bit	15	14	13	12	11	10	9	8	7	6	5	4	3	2	1	0
	E2STAT 7	E2STAT 6	E2STAT 5	E2STAT 4	E2STAT 3	E2STAT 2	E2STAT 1	E2STAT 0	E1STAT 7	E1STAT 6	E1STAT 5	E1STAT 4	E1STAT 3	E1STAT 2	E1STAT 1	E1STAT 0
Initial Value	0	0	0	0	0	0	0	0	0	0	0	0	0	0	0	0
R/W	R/W	R/W	R/W	R/W	R/W	R/W	R/W	R/W	R/W	R/W	R/W	R/W	R/W	R/W	R/W	R/W

Bit	Bit Name	Initial Value	R/W	Description
31 to 24	—	All 0	R	Reserved Whenever it is read, 0 is read. The written value will be ignored.
23 to 16	OFSTATn	All 0	R/W	This bit indicates ECCRAM1_OFn interrupt status. ECCRAM1_OFn interrupt status can be cleared writing 0 in case OFSTATn is 1. [Read operation] 0: ECCRAM1_OFn is not detected. 1: ECCRAM1_OFn is detected. [Write operation] • In case OFSTATn is 1 0: ECCRAM1_OFn interrupt status is cleared. 1: Invalid to write. • In case OFSTATn is 0 Invalid to write.
15 to 8	E2STATn	All 0	R/W	This bit indicates ECCRAM1_2En interrupt status. ECCRAM1_2En interrupt status can be cleared writing 0 in case E2STATn is 1. [Read operation] 0: ECCRAM1_2En is not detected. 1: ECCRAM1_2En is detected. [Write operation] • In case E2STATn is 1 0: ECCRAM1_2En interrupt status is cleared. 1: Invalid to write. • In case E2STATn is 0 Invalid to write.

Bit	Bit Name	Initial Value	R/W	Description
7 to 0	E1STATn	All 0	R/W	<p>This bit indicates ECCRAM1_1En interrupt status. ECCRAM1_1En interrupt status can be cleared writing 0 in case E1STATn is 1.</p> <p>[Read operation] 0: ECCRAM1_1En is not detected. 1: ECCRAM1_1En is detected.</p> <p>[Write operation] <ul style="list-style-type: none"> • In case E1STATn is 1 <ul style="list-style-type: none"> 0: ECCRAM1_1En interrupt status is cleared. 1: Invalid to write. • In case E1STATn is 0 <ul style="list-style-type: none"> Invalid to write. </p>

Note: n = 7 to 0

8.6.20 NMI Interrupt Mask Control Register (NMSK)

This register controls NMI interrupt mask.

Bit	31	30	29	28	27	26	25	24	23	22	21	20	19	18	17	16
	—	—	—	—	—	—	—	—	—	—	—	—	—	—	—	—
Initial Value	0	0	0	0	0	0	0	0	0	0	0	0	0	0	0	0
R/W	R	R	R	R	R	R	R	R	R	R	R	R	R	R	R	R
Bit	15	14	13	12	11	10	9	8	7	6	5	4	3	2	1	0
	—	—	—	—	—	—	—	—	—	—	—	—	—	—	—	NMSK
Initial Value	0	0	0	0	0	0	0	0	0	0	0	0	0	0	0	1
R/W	R	R	R	R	R	R	R	R	R	R	R	R	R	R	R	R/W

Bit	Bit Name	Initial Value	R/W	Description
31 to 1	—	All 0	R	Reserved Whenever it is read, 0 is read. The written value will be ignored.
0	NMSK	1	R/W	This bit indicates NMI interrupt mask status. [Read operation] 0: NMI interrupt mask is disabled. 1: NMI interrupt mask is enabled. [Write operation] 0: Disable NMI interrupt mask function. 1: Enable NMI interrupt mask function.

8.6.21 IRQ Interrupt Mask Control Register (IMSK)

This register controls IRQ interrupt mask.

Bit	31	30	29	28	27	26	25	24	23	22	21	20	19	18	17	16
	—	—	—	—	—	—	—	—	—	—	—	—	—	—	—	—
Initial Value	0	0	0	0	0	0	0	0	0	0	0	0	0	0	0	0
R/W	R	R	R	R	R	R	R	R	R	R	R	R	R	R	R	R
Bit	15	14	13	12	11	10	9	8	7	6	5	4	3	2	1	0
	—	—	—	—	—	—	—	—	IMSK7	IMSK6	IMSK5	IMSK4	IMSK3	IMSK2	IMSK1	IMSK0
Initial Value	0	0	0	0	0	0	0	0	1	1	1	1	1	1	1	1
R/W	R	R	R	R	R	R	R	R	R/W	R/W	R/W	R/W	R/W	R/W	R/W	R/W

Bit	Bit Name	Initial Value	R/W	Description
31 to 8	—	All 0	R	Reserved Whenever it is read, 0 is read. The written value will be ignored.
n	IMSKn	1	R/W	This bit indicates IRQn interrupt mask status. [Read operation] 0: IRQn interrupt mask is disabled. 1: IRQn interrupt mask is enabled. [Write operation] 0: Disable IRQn interrupt mask function. 1: Enable IRQn interrupt mask function.

Note: n = 7 to 0

8.6.22 TINT Interrupt Mask Control Register (TMSK)

This register controls TINT interrupt mask.

Bit	31	30	29	28	27	26	25	24	23	22	21	20	19	18	17	16
	TMSK 31	TMSK 30	TMSK 29	TMSK 28	TMSK 27	TMSK 26	TMSK 25	TMSK 24	TMSK 23	TMSK 22	TMSK 21	TMSK 20	TMSK 19	TMSK 18	TMSK 17	TMSK 16
Initial Value	1	1	1	1	1	1	1	1	1	1	1	1	1	1	1	1
R/W	R/W	R/W	R/W	R/W	R/W	R/W	R/W	R/W	R/W	R/W	R/W	R/W	R/W	R/W	R/W	R/W
Bit	15	14	13	12	11	10	9	8	7	6	5	4	3	2	1	0
	TMSK 15	TMSK 14	TMSK 13	TMSK 12	TMSK 11	TMSK 10	TMSK9	TMSK8	TMSK7	TMSK6	TMSK5	TMSK4	TMSK3	TMSK2	TMSK1	TMSK0
Initial Value	1	1	1	1	1	1	1	1	1	1	1	1	1	1	1	1
R/W	R/W	R/W	R/W	R/W	R/W	R/W	R/W	R/W	R/W	R/W	R/W	R/W	R/W	R/W	R/W	R/W

Bit	Bit Name	Initial Value	R/W	Description
n	TMSKn	1	R/W	This bit indicates TINTn interrupt mask status.

[Read operation]

0: TINTn interrupt mask is disabled.

1: TINTn interrupt mask is enabled.

[Write operation]

0: Disable TINTn interrupt mask function.

1: Enable TINTn interrupt mask function.

Note: n = 31 to 0

8.7 Operation

8.7.1 NMI Interrupt

NMI interrupt is the highest priority interrupt by default even though it can be masked.

NMI is not treated as NMI exception.

[Setting]

- A noise filter function of NMI pin can be enabled by GPIO register setting. Refer to **Section 41.4.1, Operation for GPIO Function** for detail.
- NMI pin input is detected by edge. A detection method is set by NTSEL bit of NMI Interrupt Type Selection Register (NITSR) in IAX45. It can be selected “Rising-edge detection” or “Falling-edge detection”.

[Status Control]

- NMI interrupt request can be confirmed by reading NSTAT bit of NMI Status Control Register (NSCR) in IAX45. The interrupt request can be cleared by writing 0 to NSTAT bit.
- A signal level (High or Low) of NMI pin can be confirmed by reading NSMON bit of NMI Status Control Register (NSCR) in IAX45.

[Mask Control]

- NMI interrupt can be masked by setting NMI Interrupt Mask Control Register (NMSK) in IAX45.
- NMI interrupt also can be masked by INTMASK.

8.7.2 IRQ Interrupt

IRQ interrupt is the interrupt from IRQ0-7 input pins.

[Setting]

- Using IRQ pins as interrupt must be mapped GPIO pins onto IRQ pins by GPIO register setting. Refer to **Section 41.4.2, Operation for Peripheral Function** for detail.
- A noise filter function of IRQ pins can be enabled by GPIO register setting. Refer to **Section 41.4.1, Operation for GPIO Function** for detail.
- IRQ pin inputs are detected by a level or an edge. A detection method is set by ITSEL bit of IRQ Interrupt Type Selection Register (IITSR) in IAX45. It can be selected “Low-level detection”, “Falling-edge detection”, “Rising-edge detection” or “Falling/Rising-edge detection”.

[Status Control]

- IRQ interrupt requests can be confirmed by reading ISTATn bit of IRQ Status Control Register (ISCR) in IAX45.
- In case selected a level detection in IITSR, the interrupt requests are cleared when the interrupt sources de-assert the interrupts.
- In case selected an edge detection in IITSR, the interrupt requests can be cleared by writing 0 to ISTATn bit.

[Mask Control]

- IRQ interrupt can be masked by setting IRQ Interrupt Mask Control Register (IMSK) in IAX45.
- IRQ interrupt also can be masked by INTMASK.

8.7.3 GPIO Interrupt (TINT)

GPIO interrupt is the interrupt using GPIO pins as external interrupt input pins.

[Setting]

- When using GPIO pins as interrupts, assign GPIO pins as external interrupt input pins (GPIOINT0-81) by GPIO register setting.

Refer to **Section 41.4.1, Operation for GPIO Function** for details.

Refer to **Table 8.6** for mapping GPIO pins onto GPIOINT0-81.

- The noise filter function of GPIO pins assigned to TINT can be enabled by GPIO register setting.

Refer to **Section 41.4.1, Operation for GPIO Function** for details.

- Assign any 32 interrupt sources to TINT from GPIOINT0-81 by TINT Source Selection Register (TSSR0-7) in IAX45.

Note: Even if the TINT is assigned by TSSR0-7, no interrupt request is generated unless it is assigned to an external pin interrupt by GPIO registers.

- TINT inputs are detected by a level or an edge. A detection method is set by TTSEL bit of TINT Interrupt Type Selection Register (TITSR0/1) in IAX45. It can be selected “Rising-edge detection”, “Falling-edge detection”, “High-level detection” or “Low-level detection”.

[Status Control]

- TINT interrupt requests can be confirmed by reading TSTATn bit of TINT Status Control Register (TSCR) in IAX45.
- In case selected a level detection in TITSR0/1, the interrupt requests are cleared when the interrupt sources de-assert the interrupts.
- In case selected an edge detection in TITSR0/1, the interrupt requests can be cleared by writing 0 to TSTATn bit.

[Mask Control]

- TINT interrupt can be masked by setting TINT Interrupt Mask Control Register (TMSK) in IAX45.
- TINT interrupt also can be masked by INTMASK.

Table 8.6 GPIOINT Mapping

No.	GPIO Pin	GPIOINT	No.	GPIO Pin	GPIOINT
1	P0_0	GPIOINT0	42	P8_3	GPIOINT41
2	P0_1	GPIOINT1	43	P8_4	GPIOINT42
3	P0_2	GPIOINT2	44	P9_0	GPIOINT43
4	P0_3	GPIOINT3	45	P9_1	GPIOINT44
5	P1_0	GPIOINT4	46	P9_2	GPIOINT45
6	P1_1	GPIOINT5	47	P9_3	GPIOINT46
7	P1_2	GPIOINT6	48	P10_0	GPIOINT47
8	P1_3	GPIOINT7	49	P10_1	GPIOINT48
9	P1_4	GPIOINT8	50	P10_2	GPIOINT49
10	P2_0	GPIOINT9	51	P10_3	GPIOINT50
11	P2_1	GPIOINT10	52	P10_4	GPIOINT51
12	P2_2	GPIOINT11	53	P11_0	GPIOINT52
13	P2_3	GPIOINT12	54	P11_1	GPIOINT53
14	P3_0	GPIOINT13	55	P11_2	GPIOINT54
15	P3_1	GPIOINT14	56	P11_3	GPIOINT55
16	P3_2	GPIOINT15	57	P12_0	GPIOINT56
17	P3_3	GPIOINT16	58	P12_1	GPIOINT57
18	P4_0	GPIOINT17	59	P13_0	GPIOINT58
19	P4_1	GPIOINT18	60	P13_1	GPIOINT59
20	P4_2	GPIOINT19	61	P13_2	GPIOINT60
21	P4_3	GPIOINT20	62	P13_3	GPIOINT61
22	P4_4	GPIOINT21	63	P13_4	GPIOINT62
23	P4_5	GPIOINT22	64	P14_0	GPIOINT63
24	P5_0	GPIOINT23	65	P14_1	GPIOINT64
25	P5_1	GPIOINT24	66	P14_2	GPIOINT65
26	P5_2	GPIOINT25	67	P15_0	GPIOINT66
27	P5_3	GPIOINT26	68	P15_1	GPIOINT67
28	P5_4	GPIOINT27	69	P15_2	GPIOINT68
29	P6_0	GPIOINT28	70	P15_3	GPIOINT69
30	P6_1	GPIOINT29	71	P16_0	GPIOINT70
31	P6_2	GPIOINT30	72	P16_1	GPIOINT71
32	P6_3	GPIOINT31	73	P17_0	GPIOINT72
33	P6_4	GPIOINT32	74	P17_1	GPIOINT73
34	P7_0	GPIOINT33	75	P17_2	GPIOINT74
35	P7_1	GPIOINT34	76	P17_3	GPIOINT75
36	P7_2	GPIOINT35	77	P18_0	GPIOINT76
37	P7_3	GPIOINT36	78	P18_1	GPIOINT77
38	P7_4	GPIOINT37	79	P18_2	GPIOINT78
39	P8_0	GPIOINT38	80	P18_3	GPIOINT79
40	P8_1	GPIOINT39	81	P18_4	GPIOINT80
41	P8_2	GPIOINT40	82	P18_5	GPIOINT81

8.7.4 Internal Interrupt

8.7.4.1 Bus Error Interrupt

Bus error interrupts (BUSERR_INT0-41) generated by system bus are integrated into one interrupt (BUS_ERR_INT) by IAX45 and the integrated interrupt is notified to CPU.

[Status Control]

- Bus error interrupt requests can be confirmed by reading BUS Error Interrupt Status Control Register (BEISR0/1) in IAX45.
Refer to **Table 8.7** and **Table 8.8** for mapping BESTAT0-41 onto bus error interrupt causes.
- The interrupt requests can be cleared by writing 0 to BESTAT0-41 bit.

Table 8.7 BEISR0 Bus Error Mapping

BEISR0	Interrupt	Description
BESTAT0	BUSERR_INT0	Bus Write Error Interrupt for AX45MEM
BESTAT1	BUSERR_INT1	Bus Read Error Interrupt for AX45MEM
BESTAT2	BUSERR_INT2	Bus Write Error Interrupt for AX45MMIO
BESTAT3	BUSERR_INT3	Bus Read Error Interrupt for AX45MMIO
BESTAT4	BUSERR_INT4	Bus Write Error Interrupt for DMAC_S
BESTAT5	BUSERR_INT5	Bus Read Error Interrupt for DMAC_S
BESTAT6	BUSERR_INT6	Bus Write Error Interrupt for DMAC_NS
BESTAT7	BUSERR_INT7	Bus Read Error Interrupt for DMAC_NS
BESTAT8	BUSERR_INT8	Bus Write Error Interrupt for DM_AP
BESTAT9	BUSERR_INT9	Bus Read Error Interrupt for DM_AP
BESTAT10	BUSERR_INT10	Reserved
BESTAT11	BUSERR_INT11	Reserved
BESTAT12	BUSERR_INT12	Reserved
BESTAT13	BUSERR_INT13	Reserved
BESTAT14	BUSERR_INT14	Reserved
BESTAT15	BUSERR_INT15	Reserved
BESTAT16	BUSERR_INT16	Bus Write Error Interrupt for SDHI Ch0
BESTAT17	BUSERR_INT17	Bus Read Error Interrupt for SDHI Ch0
BESTAT18	BUSERR_INT18	Bus Write Error Interrupt for SDHI Ch1
BESTAT19	BUSERR_INT19	Bus Read Error Interrupt for SDHI Ch1
BESTAT20	BUSERR_INT20	Bus Write Error Interrupt for Gether Ch0
BESTAT21	BUSERR_INT21	Bus Read Error Interrupt for Gether Ch0
BESTAT22	BUSERR_INT22	Bus Write Error Interrupt for Gether Ch1
BESTAT23	BUSERR_INT23	Bus Read Error Interrupt for Gether Ch1
BESTAT24	BUSERR_INT24	Bus Write Error Interrupt for USB Ch0 Host
BESTAT25	BUSERR_INT25	Bus Read Error Interrupt for USB Ch0 Host
BESTAT26	BUSERR_INT26	Bus Write Error Interrupt for USB Ch1 Host
BESTAT27	BUSERR_INT27	Bus Read Error Interrupt for USB Ch1 Host
BESTAT28	BUSERR_INT28	Bus Write Error Interrupt for USB Ch0 Function
BESTAT29	BUSERR_INT29	Bus Read Error Interrupt for USB Ch0 Function
BESTAT30	BUSERR_INT30	Reserved
BESTAT31	BUSERR_INT31	Reserved

Table 8.8 BEISR1 Bus Error Mapping

BEISR1	Interrupt	Description
BESTAT32	BUSERR_INT32	Reserved
BESTAT33	BUSERR_INT33	Reserved
BESTAT34	BUSERR_INT34	Reserved
BESTAT35	BUSERR_INT35	Reserved
BESTAT36	BUSERR_INT36	Reserved
BESTAT37	BUSERR_INT37	Reserved
BESTAT38	BUSERR_INT38	Reserved
BESTAT39	BUSERR_INT39	Reserved
BESTAT40	BUSERR_INT40	Reserved
BESTAT41	BUSERR_INT41	Reserved
BESTAT42	—	Reserved
BESTAT43	—	Reserved
BESTAT44	—	Reserved

8.7.4.2 ECCRAM Error Interrupt

ECCRAM error interrupts generated by On-Chip RAM (ECCRAM0, ECCRAM1) are integrated into one interrupt from eight interrupts by IAX45 and the integrated interrupt is notified to CPU.

Integrated 1bit error interrupt: EC7TIE1_0, EC7TIE1_1

Integrated 2bit error interrupt: EC7TIE2_0, EC7TIE2_1

Integrated overflow interrupt: EC7TIOVF_0, EC7TIOVF_1

[Status Control]

- ECCRAM error interrupt requests can be confirmed by reading ECCRAM Error Interrupt Status Control Register (EREISR0/1) in IAX45.
Refer to **Table 8.9** and **Table 8.10** for mapping E1STAT0-7, E2STAT0-7 and OFSTAT0-7 onto ECCRAM error interrupt causes.
- The interrupt requests can be cleared by writing 0 to E1STAT0-7, E2STAT0-7 and OFSTAT0-7 bit.

Table 8.9 ECCRAM0 ECC Error Mapping

EREISR0	Interrupt	Description	Integrated Interrupt
E1STAT0	ECCRAM0_1E0	ECC 1bit error interrupt bit[31:0]	EC7TIE1_0
E1STAT1	ECCRAM0_1E1	ECC 1bit error interrupt bit[63:32]	
E1STAT2	ECCRAM0_1E2	ECC 1bit error interrupt bit[95:64]	
E1STAT3	ECCRAM0_1E3	ECC 1bit error interrupt bit[127:96]	
E1STAT4	ECCRAM0_1E4	ECC 1bit error interrupt bit[159:128]	
E1STAT5	ECCRAM0_1E5	ECC 1bit error interrupt bit[191:160]	
E1STAT6	ECCRAM0_1E6	ECC 1bit error interrupt bit[223:192]	
E1STAT7	ECCRAM0_1E7	ECC 1bit error interrupt bit[255:224]	
E2STAT0	ECCRAM0_2E0	ECC 2bit error interrupt bit[31:0]	EC7TIE2_0
E2STAT1	ECCRAM0_2E1	ECC 2bit error interrupt bit[63:32]	
E2STAT2	ECCRAM0_2E2	ECC 2bit error interrupt bit[95:64]	
E2STAT3	ECCRAM0_2E3	ECC 2bit error interrupt bit[127:96]	
E2STAT4	ECCRAM0_2E4	ECC 2bit error interrupt bit[159:128]	
E2STAT5	ECCRAM0_2E5	ECC 2bit error interrupt bit[191:160]	
E2STAT6	ECCRAM0_2E6	ECC 2bit error interrupt bit[223:192]	
E2STAT7	ECCRAM0_2E7	ECC 2bit error interrupt bit[255:224]	
OFSTAT0	ECCRAM0_OF0	ECC error overflow interrupt bit[31:0]	EC7TIOVF_0
OFSTAT1	ECCRAM0_OF1	ECC error overflow interrupt bit[63:32]	
OFSTAT2	ECCRAM0_OF2	ECC error overflow interrupt bit[95:64]	
OFSTAT3	ECCRAM0_OF3	ECC error overflow interrupt bit[127:96]	
OFSTAT4	ECCRAM0_OF4	ECC error overflow interrupt bit[159:128]	
OFSTAT5	ECCRAM0_OF5	ECC error overflow interrupt bit[191:160]	
OFSTAT6	ECCRAM0_OF6	ECC error overflow interrupt bit[223:192]	
OFSTAT7	ECCRAM0_OF7	ECC error overflow interrupt bit[255:224]	

Table 8.10 ECCRAM1 ECC Error Mapping

EREISR1	Interrupt	Description	Integrated Interrupt
E1STAT0	ECCRAM1_1E0	ECC 1bit error interrupt bit[31:0]	EC7TIE1_1
E1STAT1	ECCRAM1_1E1	ECC 1bit error interrupt bit[63:32]	
E1STAT2	ECCRAM1_1E2	ECC 1bit error interrupt bit[95:64]	
E1STAT3	ECCRAM1_1E3	ECC 1bit error interrupt bit[127:96]	
E1STAT4	ECCRAM1_1E4	ECC 1bit error interrupt bit[159:128]	
E1STAT5	ECCRAM1_1E5	ECC 1bit error interrupt bit[191:160]	
E1STAT6	ECCRAM1_1E6	ECC 1bit error interrupt bit[223:192]	
E1STAT7	ECCRAM1_1E7	ECC 1bit error interrupt bit[255:224]	
E2STAT0	ECCRAM1_2E0	ECC 2bit error interrupt bit[31:0]	EC7TIE2_1
E2STAT1	ECCRAM1_2E1	ECC 2bit error interrupt bit[63:32]	
E2STAT2	ECCRAM1_2E2	ECC 2bit error interrupt bit[95:64]	
E2STAT3	ECCRAM1_2E3	ECC 2bit error interrupt bit[127:96]	
E2STAT4	ECCRAM1_2E4	ECC 2bit error interrupt bit[159:128]	
E2STAT5	ECCRAM1_2E5	ECC 2bit error interrupt bit[191:160]	
E2STAT6	ECCRAM1_2E6	ECC 2bit error interrupt bit[223:192]	
E2STAT7	ECCRAM1_2E7	ECC 2bit error interrupt bit[255:224]	
OFSTAT0	ECCRAM1_OF0	ECC error overflow interrupt bit[31:0]	EC7TIOVF_1
OFSTAT1	ECCRAM1_OF1	ECC error overflow interrupt bit[63:32]	
OFSTAT2	ECCRAM1_OF2	ECC error overflow interrupt bit[95:64]	
OFSTAT3	ECCRAM1_OF3	ECC error overflow interrupt bit[127:96]	
OFSTAT4	ECCRAM1_OF4	ECC error overflow interrupt bit[159:128]	
OFSTAT5	ECCRAM1_OF5	ECC error overflow interrupt bit[191:160]	
OFSTAT6	ECCRAM1_OF6	ECC error overflow interrupt bit[223:192]	
OFSTAT7	ECCRAM1_OF7	ECC error overflow interrupt bit[255:224]	

8.8 Usage Note

8.8.1 Precaution when use the peripheral modules which can initiate DMA Controller.

Some on-chip peripheral modules use the same signal both for an interrupt request and for a DMA transfer request. Refer to **Section 14.4.25, DMA Extension Resource Selectors 0/0S to 7/7S** for detail.

If such a module is selected by a DMARSn/nS register, the signal works as a DMA transfer request signal and interrupt requests to the interrupt controller are masked.

To enable the interrupt, clear the setting of DMARSn/nS (set all MID[7:0] and RID[1:0] to 0). In addition, need following register settings even if DMA controller is not used.

- Set CPG_CLKON_DMAC_REG register to supply a clock for DMA Controller.
Refer to **Section 7.2.4, Clock Control Register DMAC_REG** for register detail.
- Set CPG_RST_DMAC register to release a reset for DMA Controller.
Refer to **Section 7.2.4, Reset Control Register DMAC** for register detail.

8.8.2 Clear Timing of Interrupt Cause

Clear the interrupt cause flag in the interrupt exception service routine. It takes time from clearing the interrupt cause flag until the interrupt cause to the CPU is actually removed. Therefore, to prevent the interrupt cause that should have been cleared from being accidentally accepted again, the interrupt cause flag is read after clearing, and then the return instruction is executed.

8.8.3 Precaution when Changing Interrupt Settings

To change the NMI, IRQ, TINT interrupt settings, mask the interrupts and change the settings.

- When changing the noise filter settings.
- When switching the GPIO pins to IRQ or GPIOINT.
- When changing the source of TINT.
- When changing the interrupt detection method.

When changing the NMI, IRQ, TINT interrupt detection method to the edge type, perform the process of clearing the interrupt status after changing the setting.

- NMI: Write 0 to the NSTAT bit of NSCR.
- IRQ: Write 0 to the ISTATn bit of ISCR.
- TINT: Write 0 to the TSTATn bit of TSCR.

8.8.4 Interrupt Flow

The interrupt flow should be changed for level interrupt and edge interrupt.

Refer to Interrupt Type column of **Table 8.2** to confirm whether each interrupt is level interrupt or edge interrupt.

The following figure shows the interrupt flow for level interrupt.

The Interrupt Completion should be issued after running interrupt handler.

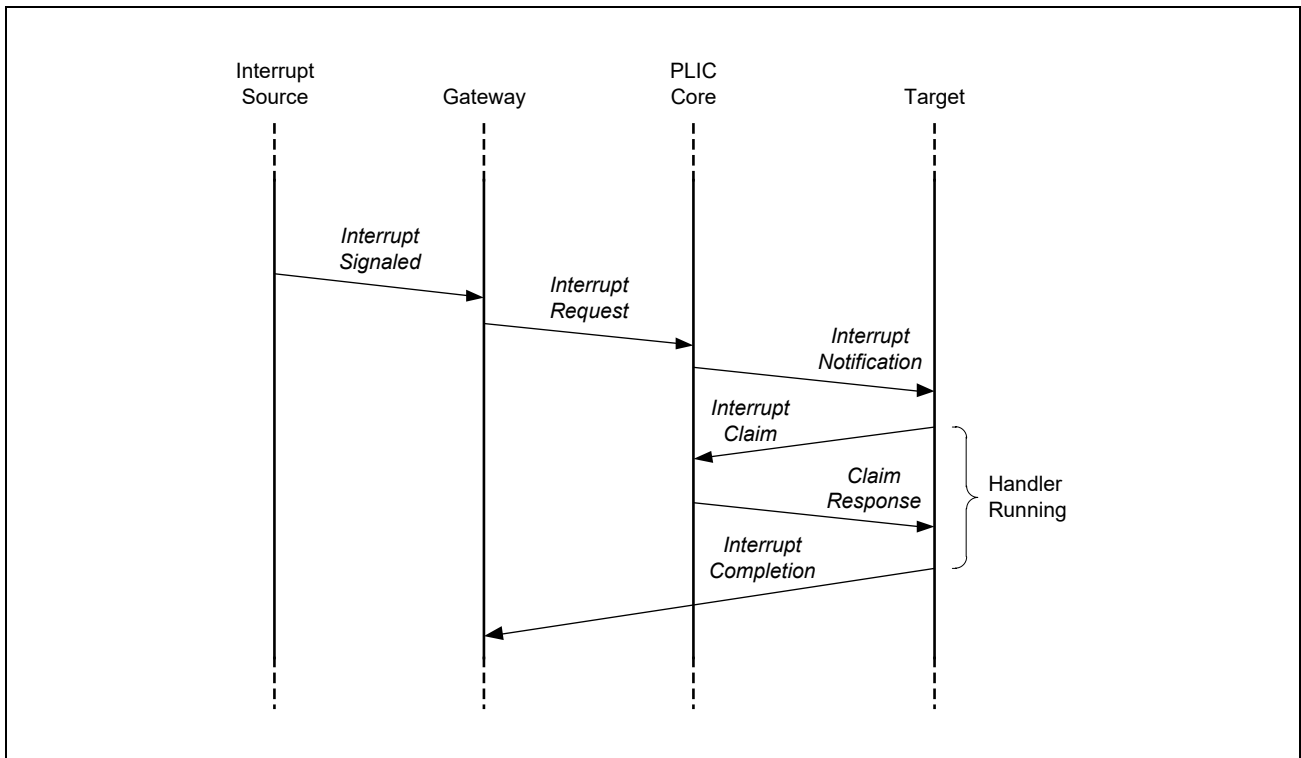

Figure 8.2 Interrupt Flow for Level Interrupt

The following figure shows the interrupt flow for edge interrupt.

The Interrupt Completion should be issued before running interrupt handler.

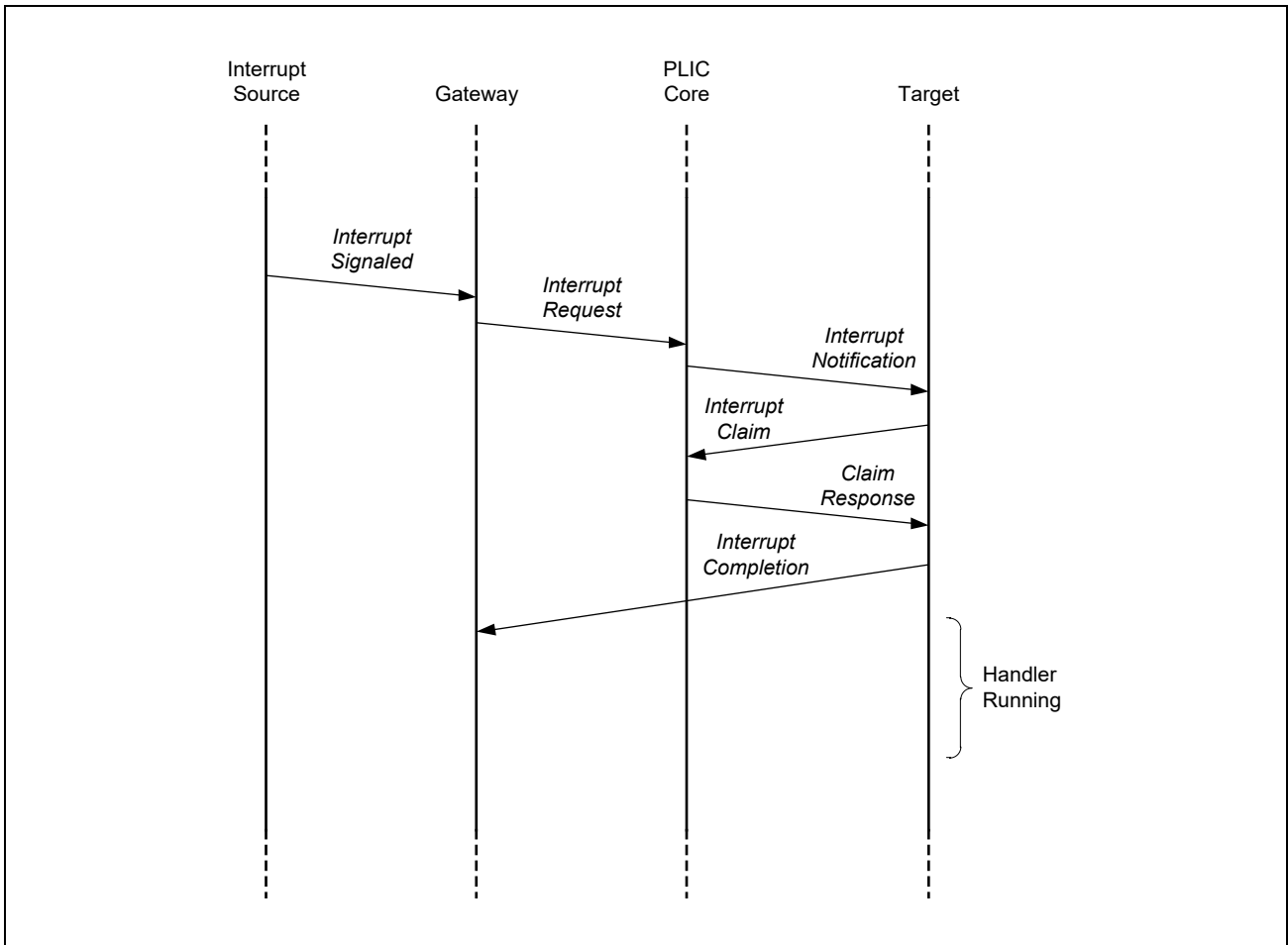

Figure 8.3 Interrupt Flow for Edge Interrupt

9. DDR3L/DDR4 SDRAM Memory Controller (MEMC)

DDR3L/DDR4 SDRAM Memory Controller (MEMC) is External Bus Controller for DDR3L/DDR4 SDRAM (DDR). This block supports up to DDR4-1600 and DDR3L-1333 SDRAM. Interface bus width is 16 bits. In line ECC can be supported.

For setup and configuration to this block, please use and refer to the linux software package of this LSI including DDR setup codes.

9.1 Features

This unit consists of MC (Memory controller) and PHY. It supports the following specifications.

- DDR3L (JEDEC STANDARD JESD79-3F, JESD79-3-1A.01)
- DDR4 (JEDEC STANDARD JESD79-4C)

Figure 9.1 shows features of this block.

Table 9.1 DDR3L/DDR4 SDRAM Memory Controller (MEMC) features

Feature	Description
DRAM IF	<ul style="list-style-type: none"> • DDR3L: 800 to 1333 Mbps (400 to 666 MHz) • DDR4: 1333 to 1600 Mbps (666 to 800 MHz) • Width: 16 bits (Full (16 bits) or Half (8 bits) data width mode) • Rank: 1, 2
MC (Memory controller)	<ul style="list-style-type: none"> • Fully pipelined command, read and write data interfaces to the controller. • Advanced bank look-ahead features for high memory throughput. • A programmable register interface to control memory parameters and protocols including auto pre-charge. • Full initialization of memory on controller reset. • ECC function for single bit and double bit error reporting, single bit error correction, and programmable removal of ECC storage.
PHY	<ul style="list-style-type: none"> • Write Leveling (Deskew CK vs Write-DQS) • Bit Leveling (Deskew DQS vs DQ/DM, Read and Write) • Vref Training (Read and Write) • Self Calibration Logic (Deskew Read vs Internal clock) • Command/Address Swizzling

The diagrams of this unit are follows.

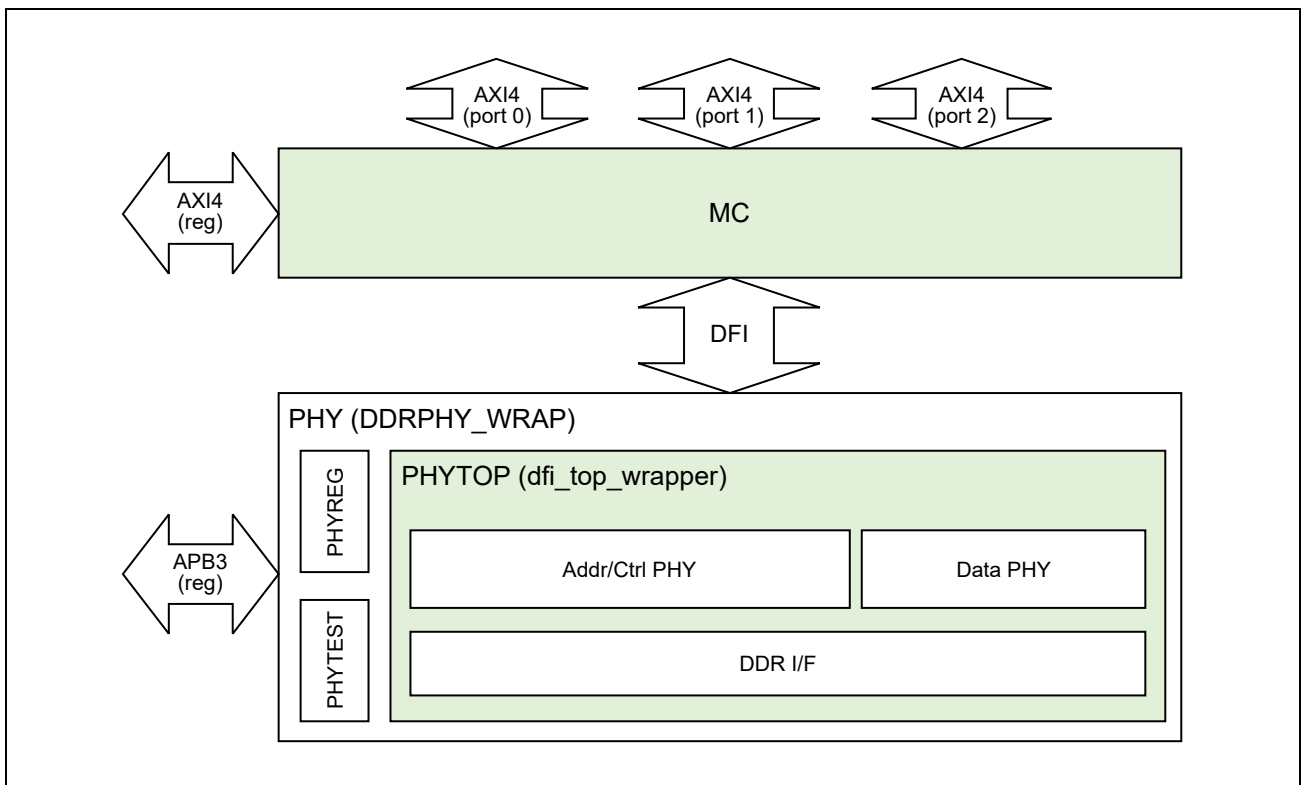

Figure 9.1 Block Diagram

This unit has the following restrictions.

DDR3L

- BC4 is not supported.
- Interleave is not supported.

DDR4

- BC4 is not supported.
- Interleave is not supported.
- Geardown Mode is not supported.
- Fine granularity refresh mode is supported, but only in Fixed x1 mode.
- CAL Mode is not supported.
- DBI is not supported.
- CRC is not supported.
- CA Parity is not supported.

9.2 Interface

9.2.1 Power, Ground

Table 9.2 shows the power and ground pins of this unit.

Table 9.2 Power, Ground

Name	I/O	Description
DDR_VDDQ	Supply	Power supply for I/O
VDD	Supply	Power supply for core
VSS	Ground	Ground for core

9.2.2 External Pins

Table 9.3 shows the external pins for DDR interface.

Table 9.3 External pin list

External pin	I/O	Description
DDR_CLK_P	O	DDR Clock (Pos)
DDR_CLK_N	O	DDR Clock (Neg)
DDR_RESET#	O	DDR Active Low Asynchronous Reset
DDR_CKE	O	DDR Clock Enable
DDR_CS0#	O	DDR Address or Command
DDR_CS1#	O	DDR Address or Command
DDR_RAS#	O	DDR Address or Command
DDR_CAS#	O	DDR Address or Command
DDR_WE#	O	DDR Address or Command
DDR_BA0 to DDR_BA2	O	DDR Address or Command
DDR_ADDR0 to DDR_ADDR15	O	DDR Address or Command
DDR_ODT0	O	DDR On Die Termination
DDR_ODT1	O	DDR On Die Termination
DDR_DQS0_P	IO	DDR Data Strobe (Pos)
DDR_DQS0_N	IO	DDR Data Strobe (Neg)
DDR_DQS1_P	IO	DDR Data Strobe (Pos)
DDR_DQS1_N	IO	DDR Data Strobe (Neg)
DDR_DQ0 to DDR_DQ15	IO	DDR Data
DDR_DM0	O	DDR Data Mask
DDR_DM1	O	DDR Data Mask
DDR_CALIBRATION	IO	Should be connected to an external 240-ohm resistor. It is used for drive and termination impedance calibration of IOs.

9.3 Usage Note

This unit has the following restrictions.

Table 9.4 External pin list

Item	Restriction
Address map	<p>It has the area (address) that access is prohibited, because it is used by the periodic training. It is as below.</p> <p>DRAM address: BA = 0, ROW = H'0, COL = H'000 to H'00F BG = 0 and 1 (only DDR4)</p> <p>System address: H'04000000 to H'0400003F (if DDR4) H'04000000 to H'0400001F (if DDR3L)</p>
Period of DRAM inaccessibility	<p>It has the period of DRAM inaccessibility to execute the periodic training. It depends only on the Bit Rate, and not on the kind of DRAM. It is belows:</p> <p>1600Mbps: 5.0 μsec every 1000 msec 1333Mbps: 1.5 μsec every 1000 msec 1066Mbps: 1.875 μsec every 1000 msec 800Mbps: 2.5 μsec every 1000 msec</p>

9.3.1 Power On

The power on sequence for the DDR_VDDQ and VDD domains is such that either the 2 voltages should be ramped up together or VDD should be ramped up prior to DDR_VDDQ in order to prevent voltage stress in the DDR IOs.

10. On-chip RAM

This LSI has an on-chip RAM for work area. These memory units can be used to store instructions or data. The operation and write access to the on-chip RAM can be enabled or disabled through the RAM enable bit (VCEN in SYS_RAMn_EN register) (n = 0-1) and RAM write enable bit (VLWEN in SYS_RAMn_EN register) (n = 0-1).

For details on the register, refer to the **Section 6.3** in chapter SYSC.

10.1 Features

■ Memory size

128 Kbytes (SRAM ACPU: 64 Kbytes, SRAM MCPU: 64 Kbytes)

■ Ports

On-chip RAM has one read and write port and is connected to the AXI bus.

■ Method of arbitration

When the same port of the on-chip RAM is accessed from different masters simultaneously, the AXI bus performs arbitration in round-robin mode.

■ Number of access cycles

The number of cycles for access to read or write is one cycle of SRAM_ACPU_ACLK (P1 ϕ).

The number of cycles for access to read or write is one cycle of SRAM_MCPU_ACLK (I2 ϕ).

11. Error Correcting Code (ECC) for On-Chip RAM

11.1 Overview

This LSI chip has two 64-Kbyte areas of on-chip RAM for use as the working area.

Each of on-chip RAM incorporates an ECC function, which allows the detection and correction of 1-bit errors and the detection of 2-bit errors. When a 1-bit or 2-bit error occurs, the address where the error occurred can be stored in an ECC error address register.

The data bus width is 256 bits. This is divided into eight channels as shown in **Figure 11.1**, with detection handled in each 32-bit channel.

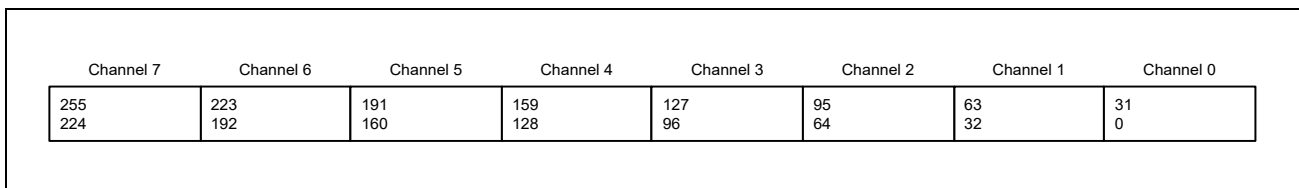

Figure 11.1 Division for ECC Processing

11.1.1 Features

- Error detection and correction
 - Detection and correction of 1-bit errors and detection of 2-bit errors are possible.
 - An error involving 3 or more bits cannot be correctly handled and may result in erroneous detection and correction.
- Control of error detection and correction
 - Error detection and correction, and correction of 1-bit errors can respectively be enabled or disabled.
- Capture of the addresses where errors occurred
 - When a 1-bit or 2-bit error is detected, the address where the error was encountered is stored in an ECC error address register. Each channel has eight ECC error address registers.
- Interrupt request
 - An interrupt request can be generated on the detection of a 1-bit error (selectable as enabled or disabled).
 - An interrupt request can be generated on the detection of a 2-bit error (selectable as enabled or disabled).
 - An overflow interrupt is generated from each channel on detection of an error when all ECC error address registers contain values.

11.2 Register Configuration

Table 11.1 and **Table 11.2** respectively show the base register and base address. The addresses of the ECC registers are represented by offsets from the base address.

Table 11.1 Base Register

Base Register Name	On-Chip RAM	Register Abbreviation
<REG_base>	SRAM ACPU	ECCRAM0
	SRAM MCPU	ECCRAM1

Table 11.2 Base Register

Base Register Name	On-Chip RAM	Register Abbreviation
<ADR_base>	SRAM ACPU	H'0_1108_0000 (Overall Address Space)
	SRAM MCPU	H'0_1109_0000 (Overall Address Space)

Table 11.3 lists the ECC registers.

Do not attempt access to the on-chip RAM areas while the registers listed in **Table 11.3** are being set.

Table 11.3 List of the ECC Registers (1/2)

Channel	Register Name	Abbreviation	R/W	Initial Value	Address	Access Size
0	ECC control register_0	<REG_base>CTL_0	R/W	H'0000_0010	<ADR_base> + H'0000	32
	ECC error address register 0_0	<REG_base>EAD0_0	R	H'0000_0000	<ADR_base> + H'0010	32
	ECC error address register 1_0	<REG_base>EAD1_0	R	H'0000_0000	<ADR_base> + H'0014	32
	ECC error address register 2_0	<REG_base>EAD2_0	R	H'0000_0000	<ADR_base> + H'0018	32
	ECC error address register 3_0	<REG_base>EAD3_0	R	H'0000_0000	<ADR_base> + H'001C	32
	ECC error address register 4_0	<REG_base>EAD4_0	R	H'0000_0000	<ADR_base> + H'0020	32
	ECC error address register 5_0	<REG_base>EAD5_0	R	H'0000_0000	<ADR_base> + H'0024	32
	ECC error address register 6_0	<REG_base>EAD6_0	R	H'0000_0000	<ADR_base> + H'0028	32
	ECC error address register 7_0	<REG_base>EAD7_0	R	H'0000_0000	<ADR_base> + H'002C	32
1	ECC control register_1	<REG_base>CTL_1	R/W	H'0000_0010	<ADR_base> + H'0040	32
	ECC error address register 0_1	<REG_base>EAD0_1	R	H'0000_0000	<ADR_base> + H'0050	32
	ECC error address register 1_1	<REG_base>EAD1_1	R	H'0000_0000	<ADR_base> + H'0054	32
	ECC error address register 2_1	<REG_base>EAD2_1	R	H'0000_0000	<ADR_base> + H'0058	32
	ECC error address register 3_1	<REG_base>EAD3_1	R	H'0000_0000	<ADR_base> + H'005C	32
	ECC error address register 4_1	<REG_base>EAD4_1	R	H'0000_0000	<ADR_base> + H'0060	32
	ECC error address register 5_1	<REG_base>EAD5_1	R	H'0000_0000	<ADR_base> + H'0064	32
	ECC error address register 6_1	<REG_base>EAD6_1	R	H'0000_0000	<ADR_base> + H'0068	32
	ECC error address register 7_1	<REG_base>EAD7_1	R	H'0000_0000	<ADR_base> + H'006C	32
2	ECC control register_2	<REG_base>CTL_2	R/W	H'0000_0010	<ADR_base> + H'0080	32
	ECC error address register 0_2	<REG_base>EAD0_2	R	H'0000_0000	<ADR_base> + H'0090	32
	ECC error address register 1_2	<REG_base>EAD1_2	R	H'0000_0000	<ADR_base> + H'0094	32
	ECC error address register 2_2	<REG_base>EAD2_2	R	H'0000_0000	<ADR_base> + H'0098	32
	ECC error address register 3_2	<REG_base>EAD3_2	R	H'0000_0000	<ADR_base> + H'009C	32
	ECC error address register 4_2	<REG_base>EAD4_2	R	H'0000_0000	<ADR_base> + H'00A0	32
	ECC error address register 5_2	<REG_base>EAD5_2	R	H'0000_0000	<ADR_base> + H'00A4	32
	ECC error address register 6_2	<REG_base>EAD6_2	R	H'0000_0000	<ADR_base> + H'00A8	32
	ECC error address register 7_2	<REG_base>EAD7_2	R	H'0000_0000	<ADR_base> + H'00AC	32
3	ECC control register_3	<REG_base>CTL_3	R/W	H'0000_0010	<ADR_base> + H'00C0	32
	ECC error address register 0_3	<REG_base>EAD0_3	R	H'0000_0000	<ADR_base> + H'00D0	32
	ECC error address register 1_3	<REG_base>EAD1_3	R	H'0000_0000	<ADR_base> + H'00D4	32
	ECC error address register 2_3	<REG_base>EAD2_3	R	H'0000_0000	<ADR_base> + H'00D8	32
	ECC error address register 3_3	<REG_base>EAD3_3	R	H'0000_0000	<ADR_base> + H'00DC	32
	ECC error address register 4_3	<REG_base>EAD4_3	R	H'0000_0000	<ADR_base> + H'00E0	32
	ECC error address register 5_3	<REG_base>EAD5_3	R	H'0000_0000	<ADR_base> + H'00E4	32
	ECC error address register 6_3	<REG_base>EAD6_3	R	H'0000_0000	<ADR_base> + H'00E8	32
	ECC error address register 7_3	<REG_base>EAD7_3	R	H'0000_0000	<ADR_base> + H'00EC	32

Table 11.3 List of the ECC Registers (2/2)

Channel	Register Name	Abbreviation	R/W	Initial Value	Address	Access Size
4	ECC control register_4	<REG_base>CTL_4	R/W	H'0000_0010	<ADR_base> + H'0100	32
	ECC error address register 0_4	<REG_base>EAD0_4	R	H'0000_0000	<ADR_base> + H'0110	32
	ECC error address register 1_4	<REG_base>EAD1_4	R	H'0000_0000	<ADR_base> + H'0114	32
	ECC error address register 2_4	<REG_base>EAD2_4	R	H'0000_0000	<ADR_base> + H'0118	32
	ECC error address register 3_4	<REG_base>EAD3_4	R	H'0000_0000	<ADR_base> + H'011C	32
	ECC error address register 4_4	<REG_base>EAD4_4	R	H'0000_0000	<ADR_base> + H'0120	32
	ECC error address register 5_4	<REG_base>EAD5_4	R	H'0000_0000	<ADR_base> + H'0124	32
	ECC error address register 6_4	<REG_base>EAD6_4	R	H'0000_0000	<ADR_base> + H'0128	32
	ECC error address register 7_4	<REG_base>EAD7_4	R	H'0000_0000	<ADR_base> + H'012C	32
5	ECC control register_5	<REG_base>CTL_5	R/W	H'0000_0010	<ADR_base> + H'0140	32
	ECC error address register 0_5	<REG_base>EAD0_5	R	H'0000_0000	<ADR_base> + H'0150	32
	ECC error address register 1_5	<REG_base>EAD1_5	R	H'0000_0000	<ADR_base> + H'0154	32
	ECC error address register 2_5	<REG_base>EAD2_5	R	H'0000_0000	<ADR_base> + H'0158	32
	ECC error address register 3_5	<REG_base>EAD3_5	R	H'0000_0000	<ADR_base> + H'015C	32
	ECC error address register 4_5	<REG_base>EAD4_5	R	H'0000_0000	<ADR_base> + H'0160	32
	ECC error address register 5_5	<REG_base>EAD5_5	R	H'0000_0000	<ADR_base> + H'0164	32
	ECC error address register 6_5	<REG_base>EAD6_5	R	H'0000_0000	<ADR_base> + H'0168	32
	ECC error address register 7_5	<REG_base>EAD7_5	R	H'0000_0000	<ADR_base> + H'016C	32
6	ECC control register_6	<REG_base>CTL_6	R/W	H'0000_0010	<ADR_base> + H'0180	32
	ECC error address register 0_6	<REG_base>EAD0_6	R	H'0000_0000	<ADR_base> + H'0190	32
	ECC error address register 1_6	<REG_base>EAD1_6	R	H'0000_0000	<ADR_base> + H'0194	32
	ECC error address register 2_6	<REG_base>EAD2_6	R	H'0000_0000	<ADR_base> + H'0198	32
	ECC error address register 3_6	<REG_base>EAD3_6	R	H'0000_0000	<ADR_base> + H'019C	32
	ECC error address register 4_6	<REG_base>EAD4_6	R	H'0000_0000	<ADR_base> + H'01A0	32
	ECC error address register 5_6	<REG_base>EAD5_6	R	H'0000_0000	<ADR_base> + H'01A4	32
	ECC error address register 6_6	<REG_base>EAD6_6	R	H'0000_0000	<ADR_base> + H'01A8	32
	ECC error address register 7_6	<REG_base>EAD7_6	R	H'0000_0000	<ADR_base> + H'01AC	32
7	ECC control register_7	<REG_base>CTL_7	R/W	H'0000_0010	<ADR_base> + H'01C0	32
	ECC error address register 0_7	<REG_base>EAD0_7	R	H'0000_0000	<ADR_base> + H'01D0	32
	ECC error address register 1_7	<REG_base>EAD1_7	R	H'0000_0000	<ADR_base> + H'01D4	32
	ECC error address register 2_7	<REG_base>EAD2_7	R	H'0000_0000	<ADR_base> + H'01D8	32
	ECC error address register 3_7	<REG_base>EAD3_7	R	H'0000_0000	<ADR_base> + H'01DC	32
	ECC error address register 4_7	<REG_base>EAD4_7	R	H'0000_0000	<ADR_base> + H'01E0	32
	ECC error address register 5_7	<REG_base>EAD5_7	R	H'0000_0000	<ADR_base> + H'01E4	32
	ECC error address register 6_7	<REG_base>EAD6_7	R	H'0000_0000	<ADR_base> + H'01E8	32
	ECC error address register 7_7	<REG_base>EAD7_7	R	H'0000_0000	<ADR_base> + H'01EC	32

11.3 Register Descriptions

11.3.1 ECC Control Registers_n (<REG_base>CTL_n) (n = 0 to 7)

Each ECC control register_n is used to control the ECC function in the corresponding channel n shown in **Figure 11.1**.

After writing the initial value to the entire usage area of the on-chip RAM, set the given ECERVF bits to 1 to enable error detection. Be sure to write 01b to the corresponding EMCA[1:0] bits to enable writing to an ECERVF bit.

For writing the initial value to the on-chip RAM areas, refer to **Section 11.5, Initializing the Detection-Usage Areas of the On-Chip RAM**.

Bit	31	30	29	28	27	26	25	24	23	22	21	20	19	18	17	16
	ECDEDF7	ECSEDF7	ECDEDF6	ECSEDF6	ECDEDF5	ECSEDF5	ECDEDF4	ECSEDF4	ECDEDF3	ECSEDF3	ECDEDF2	ECSEDF2	ECDEDF1	ECSEDF1	ECDEDF0	ECSEDF0
Initial Value	0	0	0	0	0	0	0	0	0	0	0	0	0	0	0	0
R/W	R	R	R	R	R	R	R	R	R	R	R	R	R	R	R	R
Bit	15	14	13	12	11	10	9	8	7	6	5	4	3	2	1	0
	EMCA[1:0]	—	—	—	ECOVFF	ECER2C	ECER1C	—	—	ECERVF	EC1ECP	EC2EDIC	EC1EDIC	ECER2F	ECER1F	—
Initial Value	0	0	0	0	0	0	0	0	0	0	0	1	0	0	0	0
R/W	R/W	R/W	R	R	R	R/W	R/W	R	R	R/W	R/W	R/W	R/W	R	R	R

Bit	Bit Name	Initial Value	R/W	Description
31	ECDEDF7	0	R	ECC 2-Bit Error Detection Flags ECDEDFm (m = 0 to 7)
30	ECSEDF7	0	R	These bits indicate the occurrence of 2-bit errors in the data output from the RAM while error detection is enabled. The addresses of the errors will be stored in the <REG_base>EADm_n registers.
29	ECDEDF6	0	R	
28	ECSEDF6	0	R	
27	ECDEDF5	0	R	
26	ECSEDF5	0	R	These bits indicate the occurrence of 1-bit errors in the data output from the RAM while error detection is enabled. The addresses of the errors will be stored in the <REG_base>EADm_n registers.
25	ECDEDF4	0	R	
24	ECSEDF4	0	R	
23	ECDEDF3	0	R	
22	ECSEDF3	0	R	The ECDEDFm and ECSEDFm bits are cleared to 0 under any of the following conditions. 1. Power-on reset 2. Writing 1 to the corresponding ECER2C bit 3. Setting the ECC error detection enable bit to "disabled" (ECERVF = 0) 4. Reset by WDT overflow
21	ECDEDF2	0	R	
20	ECSEDF2	0	R	
19	ECDEDF1	0	R	
18	ECSEDF1	0	R	
17	ECDEDF0	0	R	
16	ECSEDF0	0	R	
15, 14	EMCA[1:0]	00b	R/W	Enable Writing to ECERVF 01b: Enabled Others: Disabled These bits are always read as 00b.
13, 12	—	00b	R	Reserved When read, the initial value is read. When writing, be sure to write the initial value. Operation is not guaranteed if a value other than the initial value is written.

Bit	Bit Name	Initial Value	R/W	Description
11	ECOVFF	0	R	<p>ECC Overflow Detection Flag</p> <p>This bit is set to 1 and an overflow interrupt is output on detection of an error when the ECC error address registers (<REG_base>EADm_n (m = 0 to 7)) all contain data. An overflow interrupt is output even if the error is detected while the setting of this bit is already 1.</p> <p>This bit is cleared to 0 under any of the following conditions.</p> <ol style="list-style-type: none"> 1. Power-on reset 2. Writing 1 to the corresponding ECER2C bit or ECER1C bit 3. Setting the ECC error detection enable bit to "disabled" (ECERVF = 0)
10	ECER2C	0	R/W	<p>2-Bit Error Detection Flag Clear</p> <p>0: The internal state does not change. 1: The corresponding 2-bit error detection flag ECER2F is cleared.</p> <p>This bit is always read as 0.</p>
9	ECER1C	0	R/W	<p>1-Bit Error Detection Flag Clear</p> <p>0: The internal state does not change. 1: The corresponding 1-bit error detection flag ECER1F is cleared.</p> <p>This bit is always read as 0.</p>
8, 7	—	00b	R	<p>Reserved</p> <p>When read, the initial value is read. When writing, be sure to write the initial value. Operation is not guaranteed if a value other than the initial value is written.</p>
6	ECERVF	0	R/W	<p>ECC Error Detection Enable</p> <p>0: Disables error detection. 1: Enables error detection.</p> <p>1-bit error correction (EC1ECP) and interrupt control (EC2EDIC and EC1EDIC) are only possible when error detection is enabled.</p> <p><i>Note:</i> To write to this bit, the corresponding EMCA[1:0] bits must be set to 01b.</p>
5	EC1ECP	0	R/W	<p>1-Bit Error Correction Enable</p> <p>0: The error is corrected when a 1-bit error is detected. 1: The error is not corrected when a 1-bit error is detected.</p>
4	EC2EDIC	1	R/W	<p>2-Bit Error Detection Interrupt Control</p> <p>0: An interrupt is not generated when a 2-bit error is detected. 1: An interrupt is generated when a 2-bit error is detected.</p> <p>The interrupt is only generated when the corresponding 2-bit error detection flag (ECER2F) changes from 0 to 1.</p>
3	EC1EDIC	0	R/W	<p>1-Bit Error Detection Interrupt Control</p> <p>0: An interrupt is not generated when a 1-bit error is detected. 1: An interrupt is generated when a 1-bit error is detected.</p> <p>The interrupt is only generated when the corresponding 1-bit error detection flag (ECER1F) changes from 0 to 1.</p>
2	ECER2F	0	R	<p>2-Bit Error Detection Flag</p> <p>0: A 2-bit error has not occurred. 1: A 2-bit error has occurred.</p> <p>This bit is cleared to 0 under any of the following conditions.</p> <ol style="list-style-type: none"> 1. Power-on reset 2. Writing 1 to the corresponding ECER2C bit 3. Setting the ECC error detection enable bit to "disabled" (ECERVF = 0)
1	ECER1F	0	R	<p>1-Bit Error Detection Flag</p> <p>0: A 1-bit error has not occurred. 1: A 1-bit error has occurred.</p> <p>This bit is cleared to 0 under any of the following conditions.</p> <ol style="list-style-type: none"> 1. Power-on reset 2. Writing 1 to the corresponding ECER1C bit 3. Setting the ECC error detection enable bit to "disabled" (ECERVF = 0)

Bit	Bit Name	Initial Value	R/W	Description
0	—	0	R	Reserved When read, the initial value is read. When writing, be sure to write the initial value. Operation is not guaranteed if a value other than the initial value is written.

11.3.2 ECC Error Address Registers m_n (<REG_base>EADm_n) (m = 0 to 7) (n = 0 to 7)

When a 1- or 2-bit error occurs, up to eight error addresses are sequentially stored in the registers from <REG_base>EAD0_n to <REG_base>EAD7_n.

When a 2-bit error is detected while only 1-bit error addresses were stored up to <REG_base>EAD7_n, <REG_base>EAD7_n is overwritten by the address of the 2-bit error. Otherwise, it will not be overwritten. For details, refer to **Section 11.6.4, ECC Error Address Register Overwrite Conditions**.

Bit	31	30	29	28	27	26	25	24	23	22	21	20	19	18	17	16
	ECEAD0[31:16]															
Initial Value	0	0	0	0	0	0	0	0	0	0	0	0	0	0	0	0
R/W	R	R	R	R	R	R	R	R	R	R	R	R	R	R	R	R
Bit	15	14	13	12	11	10	9	8	7	6	5	4	3	2	1	0
	ECEAD0[15:0]															
Initial Value	0	0	0	0	0	0	0	0	0	0	0	0	0	0	0	0
R/W	R	R	R	R	R	R	R	R	R	R	R	R	R	R	R	R

Bit	Bit Name	Initial Value	R/W	Description
31 to 0	ECEAD0 [31:0]	All 0	R	These bits hold the address of the (m + 1)th error to have been detected. These bits are cleared to 0 under the following condition: clearing ECER2F or ECER1F in the <REG_base>CTL_n register.

11.4 Initializing the ECC Function

Initialize the ECC by following the procedure below to enable the ECC function.

1. Set the VECCEN bit in the ECCRAM setting register corresponding to the RAM area for which the ECC function is to be enabled to 1.
2. Write the initial value to the entire usage area of the RAM for which the ECC function is to be enabled.
3. Set the ECERVF bits in the ECC control registers_n to 1 to enable error detection. Then, set the respective bits to control 1-bit error correction and interrupts.

For notes on the settings of registers of this module, refer to **Section 11.6.1, Notes on Setting the Registers of This Module**.

11.5 Initializing the Detection-Usage Areas of the On-Chip RAM

Before using the ECC function, write the initial value to the entire usage area of the on-chip RAM for which the ECC function is to be enabled. The initial value can be any value. Since the detection of ECC errors is handled in 32-bit units in each channel, the initial value should also be written in 32-bit units.

Enabling error detection without initialization may cause an ECC error due to unintended reading.

Examples of Operations that May Lead to Errors

1. When writing is to proceed in 8- or 16-bit units, reading the 32-bit value from the given address and then writing the data
2. If the locations are not initialized, an ECC error may occur when the 32-bit value is read. For details on writing in 8- or 16-bit units, refer to **section 11.6.2, 8- or 16-Bit Access**.
3. When the CPU cache is enabled, if a cache miss occurs in writing, the cache being refilled by a 1-line unit
At this time if data are not initialized, an ECC error may occur because data are read in 1-line (32-byte) units.

11.6 Usage Notes

11.6.1 Notes on Setting the Registers of This Module

Ensure that none of the bus masters proceeds with access to the on-chip RAM areas while the registers listed in **Table 11.3** are being set up.

11.6.2 8- or 16-Bit Access

The ECC function for the on-chip RAM areas handles error detection in 32-bit units. Accordingly, when access is to be in 8- or 16-bit units, the operations proceed as follows.

(1) 8- or 16-bit reading

- (a) The 32 bits of data are read and the ECC is used to determine whether or not an error is present.
- (b) The 8 or 16 bits of data are then returned to the bus master that issued the read request.

(2) 8- or 16-bit writing

- (a) The 32 bits of data from the address that contains the location for writing are read and the ECC is used to determine whether or not an error is present.
- (b) The 32 bits of data that have been read are then overwritten with the 8- or 16-bit data.
- (c) The ECC value for the overwritten 32-bit data in (b) is added by writing it to the RAM.

11.6.3 Numbers of Cycles for Reading from or Writing to a RAM Area with the ECC Function Enabled

The numbers of cycles for reading from or writing to an on-chip RAM area with the ECC function enabled are as follows.

(1) Reading

The number of cycles for reading in 8- or 16-bit and 32-bit units when the ECC function is enabled is one cycle of SRAM_ACPU_ACLK or SRAM_MCPU_ACLK longer than when the ECC function is disabled.

(2) Writing

The number of cycles for writing in 8- or 16-bit units when the ECC function is enabled is two cycles of SRAM_ACPU_ACLK or SRAM_MCPU_ACLK longer than when the ECC function is disabled. The number of cycles for writing in 32-bit units when the ECC function is enabled is the same as when the ECC function is disabled.

11.6.4 ECC Error Address Register Overwrite Conditions

If a new ECC error occurs with the ECC error address stored up to <REG_base> EAD7_n, <REG_base> EAD7_n may or may not be overwritten. The conditions to be overwritten are shown below.

Error Address Storage Status Up to <REG_base> EAD7_n	New ECC Error	<REG_base>EAD7_n Overwrite	Overflow Interrupt
Only 1-bit error	1-bit error	Not overwritten	Occur
Only 1-bit error	2-bit error	Overwritten	Occur
Only 2-bit error	1-bit error	Not overwritten	Occur
Only 2-bit error	2-bit error	Not overwritten	Occur
1-bit error and 2-bit error	1-bit error	Not overwritten	Occur
1-bit error and 2-bit error	2-bit error	Not overwritten	Occur

13. Address Space Controller (TZC)

13.1 Overview

This LSI has four Address Space Controller (TZC) to realize memory access in a safe area. It performs security checks on transactions to memory or peripherals. Transactions must meet security requirements to access memory or peripherals. This is an IP (“CoreLink™ TrustZone Address Space Controller TZC-400”) provided by Arm, for details on the functions of TZC-400, see the relevant Technical Reference Manual.

NOTE

Use the TZC-related registers with their initial values.
If the register value is changed from the initial value, operation is not guaranteed.

13.1.1 Features

The TZC works between ACE-Lite masters and ACE-Lite slaves to filter bus access from master to slave. It performs filtering based on the security requirements specified in the address space.

Each TZC is installed on the interface of the following modules of this LSI.

- Internal RAM for ACPU (64 KB)
- Internal RAM for MCPU (64 KB)
- SPI Multi I/O Bus Controller
- DDR3L/DDR4 SDRAM Memory Controller

For details on the internal bus, please refer to **Section 5, LSI Internal Bus**.

The TZC provides the following key features:

- The ability to define up to eight address regions in the area map.
- A default base region to cover all remaining portions of the address map.
- Software programmable security access permissions for each address region through an APB interface. This includes the default base region, Region 0.
- Filter units only allow data transfer between an ACE-Lite master and an ACE-Lite slave if the security status of the ACE-Lite transaction and its identity match the security settings of the memory region it addresses.
- Common region configuration register settings shared between multiple filter units.
- Normal path for accesses with a much higher outstanding access support.
- Identity-based filtering of Non-secure accesses.
- Reporting and interrupt signaling that is configurable from software to manage failed permission checks. You can program the TZC to assert TZCnINT (n = 0, 1, 2, 3) when an access fails its security check.
- Gate keeper to allow or block accesses to each filter unit.
- Support for 256 outstanding transactions on the normal paths.

13.1.2 Block Diagram

Figure 13.1 shows a block diagram.

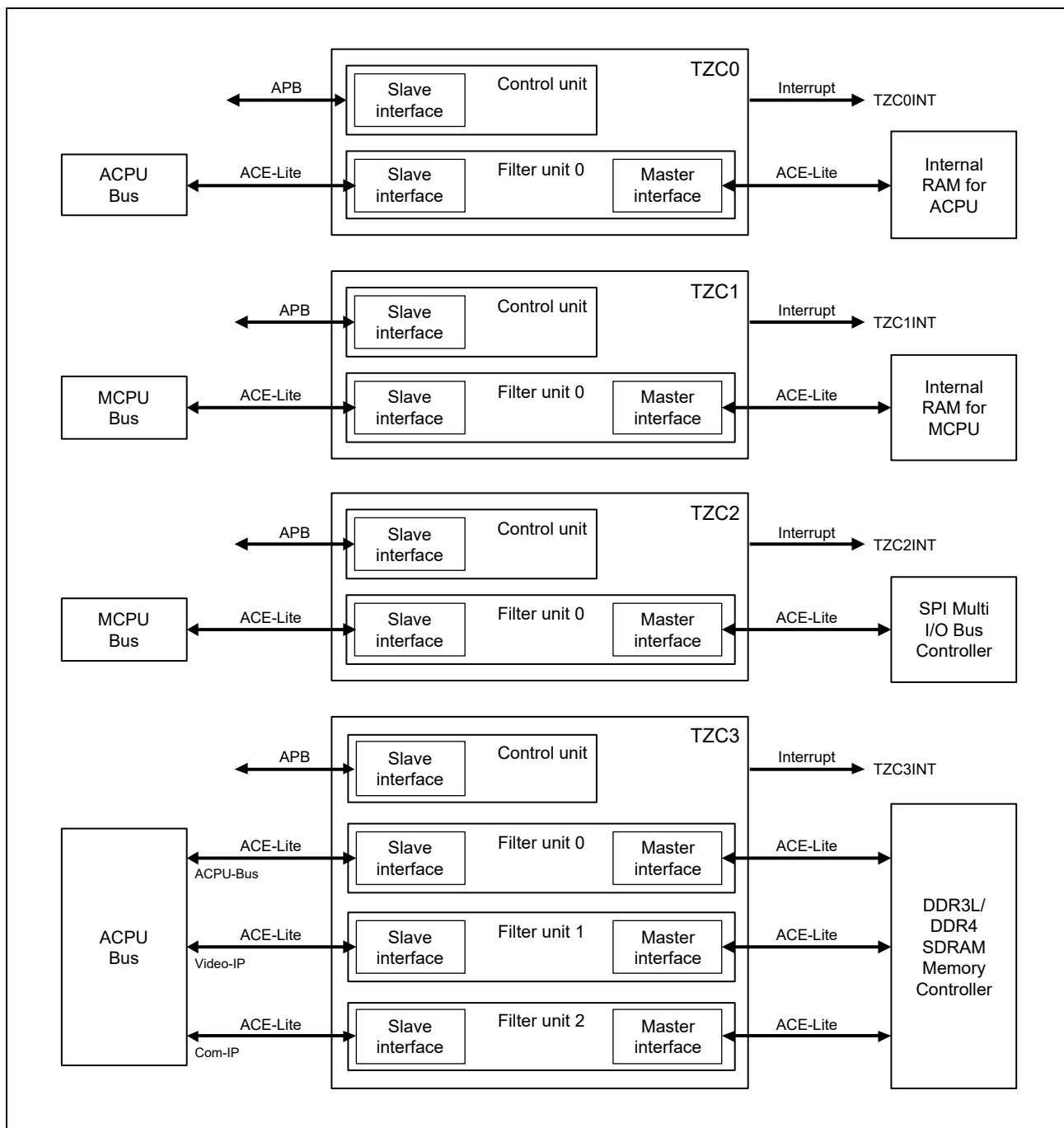

Figure 13.1 Block Diagram

Filter units perform security checks. Each filter unit has an ACE-Lite slave interface and an ACE-Lite master interface. All filter units operate from one set of shared region configuration registers. This ensures consistency across all filter units.

The number of filter units of TZC installed on each interface is as follows.

- Internal RAM for ACPU (64 KB): 1 filter unit
- Internal RAM for MCPU (64 KB): 1 filter unit
- SPI Multi I/O Bus Controller: 1 filter unit
- DDR3L/DDR4 SDRAM Memory Controller: 3 filter units
 - filter unit 0: Access from the ACPU bus passes
 - filter unit 1: Access from the Video IP passes
 - filter unit 2: Access from the Communication IP passes

13.1.3 External Pins

In TZC, there are no external pins.

13.2 Register Configuration

The base address of the TZC associated with each module is as follows:

- TZC0: Internal RAM for ACPU (64KB)
H'0_1104_0000 (AX45MP Address Space)
- TZC1: Internal RAM for MCPU (64KB)
H'0_1105_0000 (AX45MP Address Space)
- TZC2: SPI Multi I/O Bus Controller
H'0_1106_0000 (AX45MP Address Space)
- TZC3: DDR3L/DDR4 SDRAM Memory Controller
H'0_1107_0000 (AX45MP Address Space)

For details on the functions of TZC-400, see the relevant Technical Reference Manual. (ARM® CoreLink™ TZC-400 TrustZone® Address Space Controller Technical Reference Manual, Revision: r0p1)

13.3 Register Descriptions

For details on the functions of TZC-400, see the relevant Technical Reference Manual. (ARM® CoreLink™ TZC-400 TrustZone® Address Space Controller Technical Reference Manual, Revision: r0p1)

TZC has registers to specify the address area where access is controlled. Please refer Overall Address Space (**Table 5.1, Detailed Address Space**) for the addresses specified in these registers.

13.4 Operation

For details on the functions of TZC-400, see the relevant Technical Reference Manual. (ARM® CoreLink™ TZC-400 TrustZone® Address Space Controller Technical Reference Manual, Revision: r0p1)

13.5 Usage Note

For details on the functions of TZC-400, see the relevant Technical Reference Manual. (ARM® CoreLink™ TZC-400 TrustZone® Address Space Controller Technical Reference Manual, Revision: r0p1)

14. Direct Memory Access Controller

The direct memory access controller can be used in place of the CPU to perform high-speed transfers between external memory, on-chip memory, memory-mapped external devices, and on-chip peripheral modules.

This module has controllers that handles secure and non-secure access. Do not assign the same DMA transfer request to secure access and non-secure access, respectively.

14.1 Features

- Number of channels selectable: 16 channels (CH0 to CH15).
- 4-Gbyte address space (according to the architecture)
- Transfer data size: Byte, 2 bytes, 4 bytes, 8 bytes, 16 bytes, 32 bytes, 64 bytes, and 128 bytes
- Maximum transfer count: $2^{32} - 1$ bytes
- Address mode: Dual address mode
- Transfer requests: Can be selected from the two types of on-chip peripheral module request, and auto request (software trigger)
- Transfer mode: Single transfer mode and block transfer mode are selectable.
- Priority: The channel priority levels within channels 0 to 7 and within channels 8 to 15 are selectable between fixed mode and round-robin mode (the channel priority level between the group of channels 0 to 7 and the group of channels 8 to 15 is round-robin mode).
- Interrupt request: An interrupt request can be sent to the CPU on completion of data transfer (DMA transfer end interrupt per channel) or on occurrence of a transfer error (DMA error interrupt).
- The DMA registers have a continuous execution function that allows the next DMA transfer to be executed continuously by making settings for the next DMA transfer during execution of the current DMA transfer. This continuous execution function can be enabled or disabled independently in each channel.
- Link mode: In this mode, the setting data (descriptor data) located in the memory by the CPU is automatically retrieved by the DMAC, and DMA transfer is performed according to those values.
- Buffer sweep: If an ongoing DMA transfer is forced to end, the data already retrieved into the buffer can be output before DMA transfer ends.
- Interval: A specific DMA transfer interval can be specified to adjust the bus occupancy.

14.2 Input/Output Pins

Requests from external pins are not supported.

14.3 Register Configuration

The register configuration is shown in the figure below.

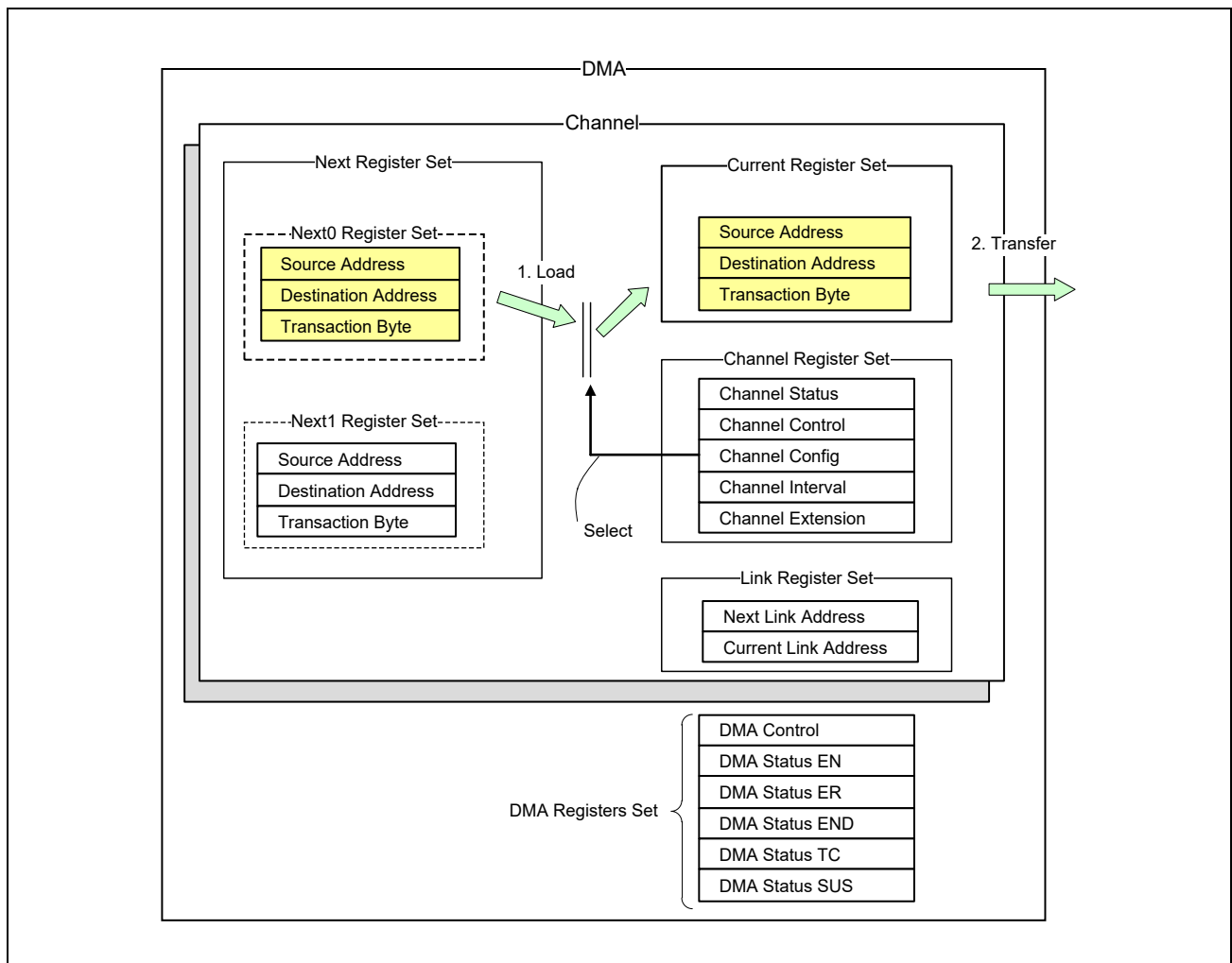

Figure 14.1 Register Configuration

(a) Next Register Set

This register set is used to set the source address, destination address, and transfer byte count of the DMA transaction to be executed next.

It consists of the Next0 register set and the Next1 register set.

In register mode, set this register set by using software. In link mode, the descriptor read data is automatically set in the Next0 register set.

These registers set values are loaded to the Current Register Set and used for DMA transfer.

(b) Current Register Set

This register set indicates the source address, destination address, and transfer byte count of the currently executed DMA transaction.

The values are loaded from the Next0/1 register set (register mode) or from the descriptor read data (link mode). The user cannot write directly to this register set.

The register set is automatically updated each time a DMA transaction is executed.

(c) Channel Register Set

This register set is used to make the DMA transfer settings.

The settings to be made with this register set include channel status indication, channel control, DMA transaction setting, and DMA transaction interval.

(d) Link Register Set

This register set consists of a register that sets the address of the descriptor to be loaded next in link mode (Next Link Address Register) and a register that indicates the address of the currently executed descriptor (Current Link Address Register).

The Current Link Address Register is automatically updated when a descriptor is read. The user cannot write directly to this register set.

(e) DMA Register Set

This register set consists of a register that controls DMA as a whole and registers that indicate the status of the corresponding channels. It enables channel priority control as well as the monitoring of the channel status (EN, ER, END, TC, and SUS).

(f) Extended Resource Selector Register Set

This register set is used to select the on-chip peripheral module to perform DMA transfer request.

14.4 Register Descriptions

Table 14.1 lists the register configuration. There are eleven control registers and five status registers for each channel, and twelve common control registers are used by all channels. In addition, there is one extension resource selector per two channels.

The notation for the registers of each channel is as follows.

- Next 0 Source Address Register of channel 0 for secure access:
Next 0 Source Address Register 0S (abbreviation: N0SA_0S)
- Next 0 Source Address Register of channel 0 for non-secure access:
Next 0 Source Address Register 0 (abbreviation: N0SA_0)

(1) AXI I/F

Base Address Name	Base Address
<Base_S0>	H'0_1180_0000 (AX45MP Address Space)
<Base_NS0>	H'0_1182_0000 (AX45MP Address Space)

Table 14.1 Register Configuration (1/11)

Channel	Register Name	Abbreviation		R/W	Initial Value	Address		Access Size
		Non-secure	Secure			Non-secure	Secure	
0	Next0 Source Address Register 0/0S	N0SA_0	N0SA_0S	RW	H'00000000	<Base_NS0> +H'0000	<Base_S0>+ H'0000	32
	Next0 Destination Address Register 0/0S	N0DA_0	N0DA_0S	RW	H'00000000	<Base_NS0> +H'0004	<Base_S0>+ H'0004	32
	Next0 Transaction Byte Register 0/0S	N0TB_0	N0TB_0S	RW	H'00000000	<Base_NS0> +H'0008	<Base_S0>+ H'0008	32
	Next1 Source Address Register 0/0S	N1SA_0	N1SA_0S	RW	H'00000000	<Base_NS0> +H'000C	<Base_S0>+ H'000C	32
	Next1 Destination Address Register 0/0S	N1DA_0	N1DA_0S	RW	H'00000000	<Base_NS0> +H'0010	<Base_S0>+ H'0010	32
	Next1 Transaction Byte Register 0/0S	N1TB_0	N1TB_0S	RW	H'00000000	<Base_NS0> +H'0014	<Base_S0>+ H'0014	32
	Current Source Address Register 0/0S	CRSA_0	CRSA_0S	R	H'00000000	<Base_NS0> +H'0018	<Base_S0>+ H'0018	32
	Current Destination Address Register 0/0S	CRDA_0	CRDA_0S	R	H'00000000	<Base_NS0> +H'001C	<Base_S0>+ H'001C	32
	Current Transaction Byte Register 0/0S	CRTB_0	CRTB_0S	R	H'00000000	<Base_NS0> +H'0020	<Base_S0>+ H'0020	32
	Channel Status Register 0/0S	CHSTAT_0	CHSTAT_0S	R	H'00000000	<Base_NS0> +H'0024	<Base_S0>+ H'0024	32
	Channel Control Register 0/0S	CHCTRL_0	CHCTRL_0S	RW	H'00000000	<Base_NS0> +H'0028	<Base_S0>+ H'0028	32
	Channel Configuration Register 0/0S	CHCFG_0	CHCFG_0S	RW	H'00000000	<Base_NS0> +H'002C	<Base_S0>+ H'002C	32
	Channel Interval Register 0/0S	CHITVL_0	CHITVL_0S	RW	H'00000000	<Base_NS0> +H'0030	<Base_S0>+ H'0030	32
	Channel Extension Register 0/0S	CHEXT_0	CHEXT_0S	RW	H'00000000	<Base_NS0> +H'0034	<Base_S0>+ H'0034	32
	Next Link Address Register 0/0S	NXLA_0	NXLA_0S	RW	H'00000000	<Base_NS0> +H'0038	<Base_S0>+ H'0038	32
	Current Link Address Register 0/0S	CRLA_0	CRLA_0S	R	H'00000000	<Base_NS0> +H'003C	<Base_S0>+ H'003C	32

Table 14.1 Register Configuration (2/11)

Channel	Register Name	Abbreviation		R/W	Initial Value	Address		Access Size
		Non-secure	Secure			Non-secure	Secure	
1	Next0 Source Address Register 1/1S	N0SA_1	N0SA_1S	RW	H'00000000	<Base_NS0>+H'0040	<Base_S0>+H'0040	32
	Next0 Destination Address Register 1/1S	N0DA_1	N0DA_1S	RW	H'00000000	<Base_NS0>+H'0044	<Base_S0>+H'0044	32
	Next0 Transaction Byte Register 1/1S	N0TB_1	N0TB_1S	RW	H'00000000	<Base_NS0>+H'0048	<Base_S0>+H'0048	32
	Next1 Source Address Register 1/1S	N1SA_1	N1SA_1S	RW	H'00000000	<Base_NS0>+H'004C	<Base_S0>+H'004C	32
	Next1 Destination Address Register 1/1S	N1DA_1	N1DA_1S	RW	H'00000000	<Base_NS0>+H'0050	<Base_S0>+H'0050	32
	Next1 Transaction Byte Register 1/1S	N1TB_1	N1TB_1S	RW	H'00000000	<Base_NS0>+H'0054	<Base_S0>+H'0054	32
	Current Source Address Register 1/1S	CRSA_1	CRSA_1S	R	H'00000000	<Base_NS0>+H'0058	<Base_S0>+H'0058	32
	Current Destination Address Register 1/1S	CRDA_1	CRDA_1S	R	H'00000000	<Base_NS0>+H'005C	<Base_S0>+H'005C	32
	Current Transaction Byte Register 1/1S	CRTB_1	CRTB_1S	R	H'00000000	<Base_NS0>+H'0060	<Base_S0>+H'0060	32
	Channel Status Register 1/1S	CHSTAT_1	CHSTAT_1S	R	H'00000000	<Base_NS0>+H'0064	<Base_S0>+H'0064	32
	Channel Control Register 1/1S	CHCTRL_1	CHCTRL_1S	RW	H'00000000	<Base_NS0>+H'0068	<Base_S0>+H'0068	32
	Channel Configuration Register 1/1S	CHCFG_1	CHCFG_1S	RW	H'00000000	<Base_NS0>+H'006C	<Base_S0>+H'006C	32
	Channel Interval Register 1/1S	CHITVL_1	CHITVL_1S	RW	H'00000000	<Base_NS0>+H'0070	<Base_S0>+H'0070	32
	Channel Extension Register 1/1S	CHEXT_1	CHEXT_1S	RW	H'00000000	<Base_NS0>+H'0074	<Base_S0>+H'0074	32
2	Next Link Address Register 1/1S	NXLA_1	NXLA_1S	RW	H'00000000	<Base_NS0>+H'0078	<Base_S0>+H'0078	32
	Current Link Address Register 1/1S	CRLA_1	CRLA_1S	R	H'00000000	<Base_NS0>+H'007C	<Base_S0>+H'007C	32
	Next0 Source Address Register 2/2S	N0SA_2	N0SA_2S	RW	H'00000000	<Base_NS0>+H'0080	<Base_S0>+H'0080	32
	Next0 Destination Address Register 2/2S	N0DA_2	N0DA_2S	RW	H'00000000	<Base_NS0>+H'0084	<Base_S0>+H'0084	32
	Next0 Transaction Byte Register 2/2S	N0TB_2	N0TB_2S	RW	H'00000000	<Base_NS0>+H'0088	<Base_S0>+H'0088	32
	Next1 Source Address Register 2/2S	N1SA_2	N1SA_2S	RW	H'00000000	<Base_NS0>+H'008C	<Base_S0>+H'008C	32
	Next1 Destination Address Register 2/2S	N1DA_2	N1DA_2S	RW	H'00000000	<Base_NS0>+H'0090	<Base_S0>+H'0090	32
	Next1 Transaction Byte Register 2/2S	N1TB_2	N1TB_2S	RW	H'00000000	<Base_NS0>+H'0094	<Base_S0>+H'0094	32
	Current Source Address Register 2/2S	CRSA_2	CRSA_2S	R	H'00000000	<Base_NS0>+H'0098	<Base_S0>+H'0098	32
	Current Destination Address Register 2/2S	CRDA_2	CRDA_2S	R	H'00000000	<Base_NS0>+H'009C	<Base_S0>+H'009C	32
Current Transaction Byte Register 2/2S	CRTB_2	CRTB_2S	R	H'00000000	<Base_NS0>+H'00A0	<Base_S0>+H'00A0	32	
Channel Status Register 2/2S	CHSTAT_2	CHSTAT_2S	R	H'00000000	<Base_NS0>+H'00A4	<Base_S0>+H'00A4	32	

Table 14.1 Register Configuration (3/11)

Channel	Register Name	Abbreviation		R/W	Initial Value	Address		Access Size
		Non-secure	Secure			Non-secure	Secure	
2	Channel Control Register 2/2S	CHCTRL_2	CHCTRL_2S	RW	H'00000000	<Base_NS0>+H'00A8	<Base_S0>+H'00A8	32
	Channel Configuration Register 2/2S	CHCFG_2	CHCFG_2S	RW	H'00000000	<Base_NS0>+H'00AC	<Base_S0>+H'00AC	32
	Channel Interval Register 2/2S	CHITVL_2	CHITVL_2S	RW	H'00000000	<Base_NS0>+H'00B0	<Base_S0>+H'00B0	32
	Channel Extension Register 2/2S	CHEXT_2	CHEXT_2S	RW	H'00000000	<Base_NS0>+H'00B4	<Base_S0>+H'00B4	32
	Next Link Address Register 2/2S	NXLA_2	NXLA_2S	RW	H'00000000	<Base_NS0>+H'00B8	<Base_S0>+H'00B8	32
	Current Link Address Register 2/2S	CRLA_2	CRLA_2S	R	H'00000000	<Base_NS0>+H'00BC	<Base_S0>+H'00BC	32
3	Next0 Source Address Register 3/3S	N0SA_3	N0SA_3S	RW	H'00000000	<Base_NS0>+H'00C0	<Base_S0>+H'00C0	32
	Next0 Destination Address Register 3/3S	N0DA_3	N0DA_3S	RW	H'00000000	<Base_NS0>+H'00C4	<Base_S0>+H'00C4	32
	Next0 Transaction Byte Register 3/3S	N0TB_3	N0TB_3S	RW	H'00000000	<Base_NS0>+H'00C8	<Base_S0>+H'00C8	32
	Next1 Source Address Register 3/3S	N1SA_3	N1SA_3S	RW	H'00000000	<Base_NS0>+H'00CC	<Base_S0>+H'00CC	32
	Next1 Destination Address Register 3/3S	N1DA_3	N1DA_3S	RW	H'00000000	<Base_NS0>+H'00D0	<Base_S0>+H'00D0	32
	Next1 Transaction Byte Register 3/3S	N1TB_3	N1TB_3S	RW	H'00000000	<Base_NS0>+H'00D4	<Base_S0>+H'00D4	32
	Current Source Address Register 3/3S	CRSA_3	CRSA_3S	R	H'00000000	<Base_NS0>+H'00D8	<Base_S0>+H'00D8	32
	Current Destination Address Register 3/3S	CRDA_3	CRDA_3S	R	H'00000000	<Base_NS0>+H'00DC	<Base_S0>+H'00DC	32
	Current Transaction Byte Register 3/3S	CRTB_3	CRTB_3S	R	H'00000000	<Base_NS0>+H'00E0	<Base_S0>+H'00E0	32
	Channel Status Register 3/3S	CHSTAT_3	CHSTAT_3S	R	H'00000000	<Base_NS0>+H'00E4	<Base_S0>+H'00E4	32
	Channel Control Register 3/3S	CHCTRL_3	CHCTRL_3S	RW	H'00000000	<Base_NS0>+H'00E8	<Base_S0>+H'00E8	32
	Channel Configuration Register 3/3S	CHCFG_3	CHCFG_3S	RW	H'00000000	<Base_NS0>+H'00EC	<Base_S0>+H'00EC	32
	Channel Interval Register 3/3S	CHITVL_3	CHITVL_3S	RW	H'00000000	<Base_NS0>+H'00F0	<Base_S0>+H'00F0	32
	Channel Extension Register 3/3S	CHEXT_3	CHEXT_3S	RW	H'00000000	<Base_NS0>+H'00F4	<Base_S0>+H'00F4	32
	Next Link Address Register 3/3S	NXLA_3	NXLA_3S	RW	H'00000000	<Base_NS0>+H'00F8	<Base_S0>+H'00F8	32
	Current Link Address Register 3/3S	CRLA_3	CRLA_3S	R	H'00000000	<Base_NS0>+H'00FC	<Base_S0>+H'00FC	32
4	Next0 Source Address Register 4/4S	N0SA_4	N0SA_4S	RW	H'00000000	<Base_NS0>+H'0100	<Base_S0>+H'0100	32
	Next0 Destination Address Register 4/4S	N0DA_4	N0DA_4S	RW	H'00000000	<Base_NS0>+H'0104	<Base_S0>+H'0104	32
	Next0 Transaction Byte Register 4/4S	N0TB_4	N0TB_4S	RW	H'00000000	<Base_NS0>+H'0108	<Base_S0>+H'0108	32
	Next1 Source Address Register 4/4S	N1SA_4	N1SA_4S	RW	H'00000000	<Base_NS0>+H'010C	<Base_S0>+H'010C	32

Table 14.1 Register Configuration (4/11)

Channel	Register Name	Abbreviation		R/W	Initial Value	Address		Access Size
		Non-secure	Secure			Non-secure	Secure	
4	Next1 Destination Address Register 4/4S	N1DA_4	N1DA_4S	RW	H'00000000	<Base_NS0>+H'0110	<Base_S0>+H'0110	32
	Next1 Transaction Byte Register 4/4S	N1TB_4	N1TB_4S	RW	H'00000000	<Base_NS0>+H'0114	<Base_S0>+H'0114	32
	Current Source Address Register 4/4S	CRSA_4	CRSA_4S	R	H'00000000	<Base_NS0>+H'0118	<Base_S0>+H'0118	32
	Current Destination Address Register 4/4S	CRDA_4	CRDA_4S	R	H'00000000	<Base_NS0>+H'011C	<Base_S0>+H'011C	32
	Current Transaction Byte Register 4/4S	CRTB_4	CRTB_4S	R	H'00000000	<Base_NS0>+H'0120	<Base_S0>+H'0120	32
	Channel Status Register 4/4S	CHSTAT_4	CHSTAT_4S	R	H'00000000	<Base_NS0>+H'0124	<Base_S0>+H'0124	32
	Channel Control Register 4/4S	CHCTRL_4	CHCTRL_4S	RW	H'00000000	<Base_NS0>+H'0128	<Base_S0>+H'0128	32
	Channel Configuration Register 4/4S	CHCFG_4	CHCFG_4S	RW	H'00000000	<Base_NS0>+H'012C	<Base_S0>+H'012C	32
	Channel Interval Register 4/4S	CHITVL_4	CHITVL_4S	RW	H'00000000	<Base_NS0>+H'0130	<Base_S0>+H'0130	32
	Channel Extension Register 4/4S	CHEXT_4	CHEXT_4S	RW	H'00000000	<Base_NS0>+H'0134	<Base_S0>+H'0134	32
	Next Link Address Register 4/4S	NXLA_4	NXLA_4S	RW	H'00000000	<Base_NS0>+H'0138	<Base_S0>+H'0138	32
	Current Link Address Register 4/4S	CRLA_4	CRLA_4S	R	H'00000000	<Base_NS0>+H'013C	<Base_S0>+H'013C	32
	5	Next0 Source Address Register 5/5S	N0SA_5	N0SA_5S	RW	H'00000000	<Base_NS0>+H'0140	<Base_S0>+H'0140
Next0 Destination Address Register 5/5S		N0DA_5	N0DA_5S	RW	H'00000000	<Base_NS0>+H'0144	<Base_S0>+H'0144	32
Next0 Transaction Byte Register 5/5S		N0TB_5	N0TB_5S	RW	H'00000000	<Base_NS0>+H'0148	<Base_S0>+H'0148	32
Next1 Source Address Register 5/5S		N1SA_5	N1SA_5S	RW	H'00000000	<Base_NS0>+H'014C	<Base_S0>+H'014C	32
Next1 Destination Address Register 5/5S		N1DA_5	N1DA_5S	RW	H'00000000	<Base_NS0>+H'0150	<Base_S0>+H'0150	32
Next1 Transaction Byte Register 5/5S		N1TB_5	N1TB_5S	RW	H'00000000	<Base_NS0>+H'0154	<Base_S0>+H'0154	32
Current Source Address Register 5/5S		CRSA_5	CRSA_5S	R	H'00000000	<Base_NS0>+H'0158	<Base_S0>+H'0158	32
Current Destination Address Register 5/5S		CRDA_5	CRDA_5S	R	H'00000000	<Base_NS0>+H'015C	<Base_S0>+H'015C	32
Current Transaction Byte Register 5/5S		CRTB_5	CRTB_5S	R	H'00000000	<Base_NS0>+H'0160	<Base_S0>+H'0160	32
Channel Status Register 5/5S		CHSTAT_5	CHSTAT_5S	R	H'00000000	<Base_NS0>+H'0164	<Base_S0>+H'0164	32
Channel Control Register 5/5S		CHCTRL_5	CHCTRL_5S	RW	H'00000000	<Base_NS0>+H'0168	<Base_S0>+H'0168	32
Channel Configuration Register 5/5S		CHCFG_5	CHCFG_5S	RW	H'00000000	<Base_NS0>+H'016C	<Base_S0>+H'016C	32
Channel Interval Register 5/5S		CHITVL_5	CHITVL_5S	RW	H'00000000	<Base_NS0>+H'0170	<Base_S0>+H'0170	32
Channel Extension Register 5/5S		CHEXT_5	CHEXT_5S	RW	H'00000000	<Base_NS0>+H'0174	<Base_S0>+H'0174	32

Table 14.1 Register Configuration (5/11)

Channel	Register Name	Abbreviation		R/W	Initial Value	Address		Access Size
		Non-secure	Secure			Non-secure	Secure	
5	Next Link Address Register 5/5S	NXLA_5	NXLA_5S	RW	H'00000000	<Base_NS0> +H'0178	<Base_S0>+ H'0178	32
	Current Link Address Register 5/5S	CRLA_5	CRLA_5S	R	H'00000000	<Base_NS0> +H'017C	<Base_S0>+ H'017C	32
6	Next0 Source Address Register 6/6S	N0SA_6	N0SA_6S	RW	H'00000000	<Base_NS0> +H'0180	<Base_S0>+ H'0180	32
	Next0 Destination Address Register 6/6S	N0DA_6	N0DA_6S	RW	H'00000000	<Base_NS0> +H'0184	<Base_S0>+ H'0184	32
	Next0 Transaction Byte Register 6/6S	N0TB_6	N0TB_6S	RW	H'00000000	<Base_NS0> +H'0188	<Base_S0>+ H'0188	32
	Next1 Source Address Register 6/6S	N1SA_6	N1SA_6S	RW	H'00000000	<Base_NS0> +H'018C	<Base_S0>+ H'018C	32
	Next1 Destination Address Register 6/6S	N1DA_6	N1DA_6S	RW	H'00000000	<Base_NS0> +H'0190	<Base_S0>+ H'0190	32
	Next1 Transaction Byte Register 6/6S	N1TB_6	N1TB_6S	RW	H'00000000	<Base_NS0> +H'0194	<Base_S0>+ H'0194	32
	Current Source Address Register 6/6S	CRSA_6	CRSA_6S	R	H'00000000	<Base_NS0> +H'0198	<Base_S0>+ H'0198	32
	Current Destination Address Register 6/6S	CRDA_6	CRDA_6S	R	H'00000000	<Base_NS0> +H'019C	<Base_S0>+ H'019C	32
	Current Transaction Byte Register 6/6S	CRTB_6	CRTB_6S	R	H'00000000	<Base_NS0> +H'01A0	<Base_S0>+ H'01A0	32
	Channel Status Register 6/6S	CHSTAT_6	CHSTAT_6S	R	H'00000000	<Base_NS0> +H'01A4	<Base_S0>+ H'01A4	32
	Channel Control Register 6/6S	CHCTRL_6	CHCTRL_6S	RW	H'00000000	<Base_NS0> +H'01A8	<Base_S0>+ H'01A8	32
	Channel Configuration Register 6/6S	CHCFG_6	CHCFG_6S	RW	H'00000000	<Base_NS0> +H'01AC	<Base_S0>+ H'01AC	32
	Channel Interval Register 6/6S	CHITVL_6	CHITVL_6S	RW	H'00000000	<Base_NS0> +H'01B0	<Base_S0>+ H'01B0	32
	Channel Extension Register 6/6S	CHEXT_6	CHEXT_6S	RW	H'00000000	<Base_NS0> +H'01B4	<Base_S0>+ H'01B4	32
	Next Link Address Register 6/6S	NXLA_6	NXLA_6S	RW	H'00000000	<Base_NS0> +H'01B8	<Base_S0>+ H'01B8	32
Current Link Address Register 6/6S	CRLA_6	CRLA_6S	R	H'00000000	<Base_NS0> +H'01BC	<Base_S0>+ H'01BC	32	
7	Next0 Source Address Register 7/7S	N0SA_7	N0SA_7S	RW	H'00000000	<Base_NS0> +H'01C0	<Base_S0>+ H'01C0	32
	Next0 Destination Address Register 7/7S	N0DA_7	N0DA_7S	RW	H'00000000	<Base_NS0> +H'01C4	<Base_S0>+ H'01C4	32
	Next0 Transaction Byte Register 7/7S	N0TB_7	N0TB_7S	RW	H'00000000	<Base_NS0> +H'01C8	<Base_S0>+ H'01C8	32
	Next1 Source Address Register 7/7S	N1SA_7	N1SA_7S	RW	H'00000000	<Base_NS0> +H'01CC	<Base_S0>+ H'01CC	32
	Next1 Destination Address Register 7/7S	N1DA_7	N1DA_7S	RW	H'00000000	<Base_NS0> +H'01D0	<Base_S0>+ H'01D0	32
	Next1 Transaction Byte Register 7/7S	N1TB_7	N1TB_7S	RW	H'00000000	<Base_NS0> +H'01D4	<Base_S0>+ H'01D4	32
	Current Source Address Register 7/7S	CRSA_7	CRSA_7S	R	H'00000000	<Base_NS0> +H'01D8	<Base_S0>+ H'01D8	32
	Current Destination Address Register 7/7S	CRDA_7	CRDA_7S	R	H'00000000	<Base_NS0> +H'01DC	<Base_S0>+ H'01DC	32

Table 14.1 Register Configuration (6/11)

Channel	Register Name	Abbreviation		R/W	Initial Value	Address		Access Size
		Non-secure	Secure			Non-secure	Secure	
7	Current Transaction Byte Register 7/7S	CRTB_7	CRTB_7S	R	H'00000000	<Base_NS0>+H'01E0	<Base_S0>+H'01E0	32
	Channel Status Register 7/7S	CHSTAT_7	CHSTAT_7S	R	H'00000000	<Base_NS0>+H'01E4	<Base_S0>+H'01E4	32
	Channel Control Register 7/7S	CHCTRL_7	CHCTRL_7S	RW	H'00000000	<Base_NS0>+H'01E8	<Base_S0>+H'01E8	32
	Channel Configuration Register 7/7S	CHCFG_7	CHCFG_7S	RW	H'00000000	<Base_NS0>+H'01EC	<Base_S0>+H'01EC	32
	Channel Interval Register 7/7S	CHITVL_7	CHITVL_7S	RW	H'00000000	<Base_NS0>+H'01F0	<Base_S0>+H'01F0	32
	Channel Extension Register 7/7S	CHEXT_7	CHEXT_7S	RW	H'00000000	<Base_NS0>+H'01F4	<Base_S0>+H'01F4	32
	Next Link Address Register 7/7S	NXLA_7	NXLA_7S	RW	H'00000000	<Base_NS0>+H'01F8	<Base_S0>+H'01F8	32
	Current Link Address Register 7/7S	CRLA_7	CRLA_7S	R	H'00000000	<Base_NS0>+H'01FC	<Base_S0>+H'01FC	32
Common for 0 to 7	DMA Control Registers 0-7/0-7S	DCTRL_0_7	DCTRL_0_7S	RW	H'00000000	<Base_NS0>+H'0300	<Base_S0>+H'0300	32
	DMA Status EN Registers 0-7/0-7S	DSTAT_EN_0_7	DSTAT_EN_0_7S	R	H'00000000	<Base_NS0>+H'0310	<Base_S0>+H'0310	32
	DMA Status ER Registers 0-7/0-7S	DSTAT_ER_0_7	DSTAT_ER_0_7S	R	H'00000000	<Base_NS0>+H'0314	<Base_S0>+H'0314	32
	DMA Status END Registers 0-7/0-7S	DSTAT_END_0_7	DSTAT_END_0_7S	R	H'00000000	<Base_NS0>+H'0318	<Base_S0>+H'0318	32
	DMA Status TC Registers 0-7/0-7S	DSTAT_TC_0_7	DSTAT_TC_0_7S	R	H'00000000	<Base_NS0>+H'031C	<Base_S0>+H'031C	32
	DMA Status SUS Registers 0-7/0-7S	DSTAT_SUS_0_7	DSTAT_SUS_0_7S	R	H'00000000	<Base_NS0>+H'0320	<Base_S0>+H'0320	32
8	Next0 Source Address Register 8/8S	N0SA_8	N0SA_8S	RW	H'00000000	<Base_NS0>+H'0400	<Base_S0>+H'0400	32
	Next0 Destination Address Register 8/8S	N0DA_8	N0DA_8S	RW	H'00000000	<Base_NS0>+H'0404	<Base_S0>+H'0404	32
	Next0 Transaction Byte Register 8/8S	N0TB_8	N0TB_8S	RW	H'00000000	<Base_NS0>+H'0408	<Base_S0>+H'0408	32
	Next1 Source Address Register 8/8S	N1SA_8	N1SA_8S	RW	H'00000000	<Base_NS0>+H'040C	<Base_S0>+H'040C	32
	Next1 Destination Address Register 8/8S	N1DA_8	N1DA_8S	RW	H'00000000	<Base_NS0>+H'0410	<Base_S0>+H'0410	32
	Next1 Transaction Byte Register 8/8S	N1TB_8	N1TB_8S	RW	H'00000000	<Base_NS0>+H'0414	<Base_S0>+H'0414	32
	Current Source Address Register 8/8S	CRSA_8	CRSA_8S	R	H'00000000	<Base_NS0>+H'0418	<Base_S0>+H'0418	32
	Current Destination Address Register 8/8S	CRDA_8	CRDA_8S	R	H'00000000	<Base_NS0>+H'041C	<Base_S0>+H'041C	32
	Current Transaction Byte Register 8/8S	CRTB_8	CRTB_8S	R	H'00000000	<Base_NS0>+H'0420	<Base_S0>+H'0420	32
	Channel Status Register 8/8S	CHSTAT_8	HSTAT_8S	R	H'00000000	<Base_NS0>+H'0424	<Base_S0>+H'0424	32
	Channel Control Register 8/8S	CHCTRL_8	CHCTRL_8S	RW	H'00000000	<Base_NS0>+H'0428	<Base_S0>+H'0428	32
	Channel Configuration Register 8/8S	CHCFG_8	CHCFG_8S	RW	H'00000000	<Base_NS0>+H'042C	<Base_S0>+H'042C	32

Table 14.1 Register Configuration (7/11)

Channel	Register Name	Abbreviation		R/W	Initial Value	Address		Access Size
		Non-secure	Secure			Non-secure	Secure	
8	Channel Interval Register 8/8S	CHITVL_8	CHITVL_8S	RW	H'00000000	<Base_NS0> +H'0430	<Base_S0>+ H'0430	32
	Channel Extension Register 8/8S	CHEXT_8	CHEXT_8S	RW	H'00000000	<Base_NS0> +H'0434	<Base_S0>+ H'0434	32
	Next Link Address Register 8/8S	NXLA_8	NXLA_8S	RW	H'00000000	<Base_NS0> +H'0438	<Base_S0>+ H'0438	32
	Current Link Address Register 8/8S	CRLA_8	CRLA_8S	R	H'00000000	<Base_NS0> +H'043C	<Base_S0>+ H'043C	32
9	Next0 Source Address Register 9/9S	N0SA_9	N0SA_9S	RW	H'00000000	<Base_NS0> +H'0440	<Base_S0>+ H'0440	32
	Next0 Destination Address Register 9/9S	N0DA_9	N0DA_9S	RW	H'00000000	<Base_NS0> +H'0444	<Base_S0>+ H'0444	32
	Next0 Transaction Byte Register 9/9S	N0TB_9	N0TB_9S	RW	H'00000000	<Base_NS0> +H'0448	<Base_S0>+ H'0448	32
	Next1 Source Address Register 9/9S	N1SA_9	N1SA_9S	RW	H'00000000	<Base_NS0> +H'044C	<Base_S0>+ H'044C	32
	Next1 Destination Address Register 9/9S	N1DA_9	N1DA_9S	RW	H'00000000	<Base_NS0> +H'0450	<Base_S0>+ H'0450	32
	Next1 Transaction Byte Register 9/9S	N1TB_9	N1TB_9S	RW	H'00000000	<Base_NS0> +H'0454	<Base_S0>+ H'0454	32
	Current Source Address Register 9/9S	CRSA_9	CRSA_9S	R	H'00000000	<Base_NS0> +H'0458	<Base_S0>+ H'0458	32
	Current Destination Address Register 9/9S	CRDA_9	CRDA_9S	R	H'00000000	<Base_NS0> +H'045C	<Base_S0>+ H'045C	32
	Current Transaction Byte Register 9/9S	CRTB_9	CRTB_9S	R	H'00000000	<Base_NS0> +H'0460	<Base_S0>+ H'0460	32
	Channel Status Register 9/9S	CHSTAT_9	CHSTAT_9S	R	H'00000000	<Base_NS0> +H'0464	<Base_S0>+ H'0464	32
	Channel Control Register 9/9S	CHCTRL_9	CHCTRL_9S	RW	H'00000000	<Base_NS0> +H'0468	<Base_S0>+ H'0468	32
	Channel Configuration Register 9/9S	CHCFG_9	CHCFG_9S	RW	H'00000000	<Base_NS0> +H'046C	<Base_S0>+ H'046C	32
	Channel Interval Register 9/9S	CHITVL_9	CHITVL_9S	RW	H'00000000	<Base_NS0> +H'0470	<Base_S0>+ H'0470	32
	Channel Extension Register 9/9S	CHEXT_9	CHEXT_9S	RW	H'00000000	<Base_NS0> +H'0474	<Base_S0>+ H'0474	32
	Next Link Address Register 9/9S	NXLA_9	NXLA_9S	RW	H'00000000	<Base_NS0> +H'0478	<Base_S0>+ H'0478	32
	Current Link Address Register 9/9S	CRLA_9	CRLA_9S	R	H'00000000	<Base_NS0> +H'047C	<Base_S0>+ H'047C	32
10	Next0 Source Address Register 10/10S	N0SA_10	N0SA_10S	RW	H'00000000	<Base_NS0> +H'0480	<Base_S0>+ H'0480	32
	Next0 Destination Address Register 10/10S	N0DA_10	N0DA_10S	RW	H'00000000	<Base_NS0> +H'0484	<Base_S0>+ H'0484	32
	Next0 Transaction Byte Register 10/10S	N0TB_10	N0TB_10S	RW	H'00000000	<Base_NS0> +H'0488	<Base_S0>+ H'0488	32
	Next1 Source Address Register 10/10S	N1SA_10	N1SA_10S	RW	H'00000000	<Base_NS0> +H'048C	<Base_S0>+ H'048C	32
	Next1 Destination Address Register 10/10S	N1DA_10	N1DA_10S	RW	H'00000000	<Base_NS0> +H'0490	<Base_S0>+ H'0490	32
	Next1 Transaction Byte Register 10/10S	N1TB_10	N1TB_10S	RW	H'00000000	<Base_NS0> +H'0494	<Base_S0>+ H'0494	32

Table 14.1 Register Configuration (8/11)

Channel	Register Name	Abbreviation		R/W	Initial Value	Address		Access Size
		Non-secure	Secure			Non-secure	Secure	
10	Current Source Address Register 10/10S	CRSA_10	CRSA_10S	R	H'00000000	<Base_NS0>+H'0498	<Base_S0>+H'0498	32
	Current Destination Address Register 10/10S	CRDA_10	CRDA_10S	R	H'00000000	<Base_NS0>+H'049C	<Base_S0>+H'049C	32
	Current Transaction Byte Register 10/10S	CRTB_10	CRTB_10S	R	H'00000000	<Base_NS0>+H'04A0	<Base_S0>+H'04A0	32
	Channel Status Register 10/10S	CHSTAT_10	CHSTAT_10S	R	H'00000000	<Base_NS0>+H'04A4	<Base_S0>+H'04A4	32
	Channel Control Register 10/10S	CHCTRL_10	CHCTRL_10S	RW	H'00000000	<Base_NS0>+H'04A8	<Base_S0>+H'04A8	32
	Channel Configuration Register 10/10S	CHCFG_10	CHCFG_10S	RW	H'00000000	<Base_NS0>+H'04AC	<Base_S0>+H'04AC	32
	Channel Interval Register 10/10S	CHITVL_10	CHITVL_10S	RW	H'00000000	<Base_NS0>+H'04B0	<Base_S0>+H'04B0	32
	Channel Extension Register 10/10S	CHEXT_10	CHEXT_10S	RW	H'00000000	<Base_NS0>+H'04B4	<Base_S0>+H'04B4	32
	Next Link Address Register 10/10S	NXLA_10	NXLA_10S	RW	H'00000000	<Base_NS0>+H'04B8	<Base_S0>+H'04B8	32
	Current Link Address Register 10/10S	CRLA_10	CRLA_10S	R	H'00000000	<Base_NS0>+H'04BC	<Base_S0>+H'04BC	32
11	Next0 Source Address Register 11/11S	N0SA_11	N0SA_11S	RW	H'00000000	<Base_NS0>+H'04C0	<Base_S0>+H'04C0	32
	Next0 Destination Address Register 11/11S	N0DA_11	N0DA_11S	RW	H'00000000	<Base_NS0>+H'04C4	<Base_S0>+H'04C4	32
	Next0 Transaction Byte Register 11/11S	N0TB_11	N0TB_11S	RW	H'00000000	<Base_NS0>+H'04C8	<Base_S0>+H'04C8	32
	Next1 Source Address Register 11/11S	N1SA_11	N1SA_11S	RW	H'00000000	<Base_NS0>+H'04CC	<Base_S0>+H'04CC	32
	Next1 Destination Address Register 11/11S	N1DA_11	N1DA_11S	RW	H'00000000	<Base_NS0>+H'04D0	<Base_S0>+H'04D0	32
	Next1 Transaction Byte Register 11/11S	N1TB_11	N1TB_11S	RW	H'00000000	<Base_NS0>+H'04D4	<Base_S0>+H'04D4	32
	Current Source Address Register 11/11S	CRSA_11	CRSA_11S	R	H'00000000	<Base_NS0>+H'04D8	<Base_S0>+H'04D8	32
	Current Destination Address Register 11/11S	CRDA_11	CRDA_11S	R	H'00000000	<Base_NS0>+H'04DC	<Base_S0>+H'04DC	32
	Current Transaction Byte Register 11/11S	CRTB_11	CRTB_11S	R	H'00000000	<Base_NS0>+H'04E0	<Base_S0>+H'04E0	32
	Channel Status Register 11/11S	CHSTAT_11	CHSTAT_11S	R	H'00000000	<Base_NS0>+H'04E4	<Base_S0>+H'04E4	32
	Channel Control Register 11/11S	CHCTRL_11	CHCTRL_11S	RW	H'00000000	<Base_NS0>+H'04E8	<Base_S0>+H'04E8	32
	Channel Configuration Register 11/11S	CHCFG_11	CHCFG_11S	RW	H'00000000	<Base_NS0>+H'04EC	<Base_S0>+H'04EC	32
	Channel Interval Register 11/11S	CHITVL_11	CHITVL_11S	RW	H'00000000	<Base_NS0>+H'04F0	<Base_S0>+H'04F0	32
	Channel Extension Register 11/11S	CHEXT_11	CHEXT_11S	RW	H'00000000	<Base_NS0>+H'04F4	<Base_S0>+H'04F4	32
	Next Link Address Register 11/11S	NXLA_11	NXLA_11S	RW	H'00000000	<Base_NS0>+H'04F8	<Base_S0>+H'04F8	32
	Current Link Address Register 11/11S	CRLA_11	CRLA_11S	R	H'00000000	<Base_NS0>+H'04FC	<Base_S0>+H'04FC	32

Table 14.1 Register Configuration (9/11)

Channel	Register Name	Abbreviation		R/W	Initial Value	Address		Access Size
		Non-secure	Secure			Non-secure	Secure	
12	Next0 Source Address Register 12/12S	N0SA_12	N0SA_12S	RW	H'00000000	<Base_NS0>+H'0500	<Base_S0>+H'0500	32
	Next0 Destination Address Register 12/12S	N0DA_12	N0DA_12S	RW	H'00000000	<Base_NS0>+H'0504	<Base_S0>+H'0504	32
	Next0 Transaction Byte Register 12/12S	N0TB_12	N0TB_12S	RW	H'00000000	<Base_NS0>+H'0508	<Base_S0>+H'0508	32
	Next1 Source Address Register 12/12S	N1SA_12	N1SA_12S	RW	H'00000000	<Base_NS0>+H'050C	<Base_S0>+H'050C	32
	Next1 Destination Address Register 12/12S	N1DA_12	N1DA_12S	RW	H'00000000	<Base_NS0>+H'0510	<Base_S0>+H'0510	32
	Next1 Transaction Byte Register 12/12S	N1TB_12	N1TB_12S	RW	H'00000000	<Base_NS0>+H'0514	<Base_S0>+H'0514	32
	Current Source Address Register 12/12S	CRSA_12	CRSA_12S	R	H'00000000	<Base_NS0>+H'0518	<Base_S0>+H'0518	32
	Current Destination Address Register 12/12S	CRDA_12	CRDA_12S	R	H'00000000	<Base_NS0>+H'051C	<Base_S0>+H'051C	32
	Current Transaction Byte Register 12/12S	CRTB_12	CRTB_12S	R	H'00000000	<Base_NS0>+H'0520	<Base_S0>+H'0520	32
	Channel Status Register 12/12S	CHSTAT_12	CHSTAT_12S	R	H'00000000	<Base_NS0>+H'0524	<Base_S0>+H'0524	32
	Channel Control Register 12/12S	CHCTRL_12	CHCTRL_12S	RW	H'00000000	<Base_NS0>+H'0528	<Base_S0>+H'0528	32
	Channel Configuration Register 12/12S	CHCFG_12	CHCFG_12S	RW	H'00000000	<Base_NS0>+H'052C	<Base_S0>+H'052C	32
	Channel Interval Register 12/12S	CHITVL_12	CHITVL_12S	RW	H'00000000	<Base_NS0>+H'0530	<Base_S0>+H'0530	32
	Channel Extension Register 12/12S	CHEXT_12	CHEXT_12S	RW	H'00000000	<Base_NS0>+H'0534	<Base_S0>+H'0534	32
	Next Link Address Register 12/12S	NXLA_12	NXLA_12S	RW	H'00000000	<Base_NS0>+H'0538	<Base_S0>+H'0538	32
Current Link Address Register 12/12S	CRLA_12	CRLA_12S	R	H'00000000	<Base_NS0>+H'053C	<Base_S0>+H'053C	32	
13	Next0 Source Address Register 13/13S	N0SA_13	N0SA_13S	RW	H'00000000	<Base_NS0>+H'0540	<Base_S0>+H'0540	32
	Next0 Destination Address Register 13/13S	N0DA_13	N0DA_13S	RW	H'00000000	<Base_NS0>+H'0544	<Base_S0>+H'0544	32
	Next0 Transaction Byte Register 13/13S	N0TB_13	N0TB_13S	RW	H'00000000	<Base_NS0>+H'0548	<Base_S0>+H'0548	32
	Next1 Source Address Register 13/13S	N1SA_13	N1SA_13S	RW	H'00000000	<Base_NS0>+H'054C	<Base_S0>+H'054C	32
	Next1 Destination Address Register 13/13S	N1DA_13	N1DA_13S	RW	H'00000000	<Base_NS0>+H'0550	<Base_S0>+H'0550	32
	Next1 Transaction Byte Register 13/13S	N1TB_13	N1TB_13S	RW	H'00000000	<Base_NS0>+H'0554	<Base_S0>+H'0554	32
	Current Source Address Register 13/13S	CRSA_13	CRSA_13S	R	H'00000000	<Base_NS0>+H'0558	<Base_S0>+H'0558	32
	Current Destination Address Register 13/13S	CRDA_13	CRDA_13S	R	H'00000000	<Base_NS0>+H'055C	<Base_S0>+H'055C	32
	Current Transaction Byte Register 13/13S	CRTB_13	CRTB_13S	R	H'00000000	<Base_NS0>+H'0560	<Base_S0>+H'0560	32
	Channel Status Register 13/13S	CHSTAT_13	CHSTAT_13S	R	H'00000000	<Base_NS0>+H'0564	<Base_S0>+H'0564	32

Table 14.1 Register Configuration (10/11)

Channel	Register Name	Abbreviation		R/W	Initial Value	Address		Access Size
		Non-secure	Secure			Non-secure	Secure	
13	Channel Control Register 13/13S	CHCTRL_13	CHCTRL_13S	RW	H'00000000	<Base_NS0>+H'0568	<Base_S0>+H'0568	32
	Channel Configuration Register 13/13S	CHCFG_13	CHCFG_13S	RW	H'00000000	<Base_NS0>+H'056C	<Base_S0>+H'056C	32
	Channel Interval Register 13/13S	CHITVL_13	CHITVL_13S	RW	H'00000000	<Base_NS0>+H'0570	<Base_S0>+H'0570	32
	Channel Extension Register 13/13S	CHEXT_13	CHEXT_13S	RW	H'00000000	<Base_NS0>+H'0574	<Base_S0>+H'0574	32
	Next Link Address Register 13/13S	NXLA_13	NXLA_13S	RW	H'00000000	<Base_NS0>+H'0578	<Base_S0>+H'0578	32
	Current Link Address Register 13/13S	CRLA_13	CRLA_13S	R	H'00000000	<Base_NS0>+H'057C	<Base_S0>+H'057C	32
14	Next0 Source Address Register 14/14S	N0SA_14	N0SA_14S	RW	H'00000000	<Base_NS0>+H'0580	<Base_S0>+H'0580	32
	Next0 Destination Address Register 14/14S	N0DA_14	N0DA_14S	RW	H'00000000	<Base_NS0>+H'0584	<Base_S0>+H'0584	32
	Next0 Transaction Byte Register 14/14S	N0TB_14	N0TB_14S	RW	H'00000000	<Base_NS0>+H'0588	<Base_S0>+H'0588	32
	Next1 Source Address Register 14/14S	N1SA_14	N1SA_14S	RW	H'00000000	<Base_NS0>+H'058C	<Base_S0>+H'058C	32
	Next1 Destination Address Register 14/14S	N1DA_14	N1DA_14S	RW	H'00000000	<Base_NS0>+H'0590	<Base_S0>+H'0590	32
	Next1 Transaction Byte Register 14/14S	N1TB_14	N1TB_14S	RW	H'00000000	<Base_NS0>+H'0594	<Base_S0>+H'0594	32
	Current Source Address Register 14/14S	CRSA_14	CRSA_14S	R	H'00000000	<Base_NS0>+H'0598	<Base_S0>+H'0598	32
	Current Destination Address Register 14/14S	CRDA_14	CRDA_14S	R	H'00000000	<Base_NS0>+H'059C	<Base_S0>+H'059C	32
	Current Transaction Byte Register 14/14S	CRTB_14	CRTB_14S	R	H'00000000	<Base_NS0>+H'05A0	<Base_S0>+H'05A0	32
	Channel Status Register 14/14S	CHSTAT_14	CHSTAT_14S	R	H'00000000	<Base_NS0>+H'05A4	<Base_S0>+H'05A4	32
	Channel Control Register 14/14S	CHCTRL_14	CHCTRL_14S	RW	H'00000000	<Base_NS0>+H'05A8	<Base_S0>+H'05A8	32
	Channel Configuration Register 14/14S	CHCFG_14	CHCFG_14S	RW	H'00000000	<Base_NS0>+H'05AC	<Base_S0>+H'05AC	32
	Channel Interval Register 14/14S	CHITVL_14	CHITVL_14S	RW	H'00000000	<Base_NS0>+H'05B0	<Base_S0>+H'05B0	32
	Channel Extension Register 14/14S	CHEXT_14	CHEXT_14S	RW	H'00000000	<Base_NS0>+H'05B4	<Base_S0>+H'05B4	32
	Next Link Address Register 14/14S	NXLA_14	NXLA_14S	RW	H'00000000	<Base_NS0>+H'05B8	<Base_S0>+H'05B8	32
	Current Link Address Register 14/14S	CRLA_14	CRLA_14S	R	H'00000000	<Base_NS0>+H'05BC	<Base_S0>+H'05BC	32
15	Next0 Source Address Register 15/15S	N0SA_15	N0SA_15S	RW	H'00000000	<Base_NS0>+H'05C0	<Base_S0>+H'05C0	32
	Next0 Destination Address Register 15/15S	N0DA_15	N0DA_15S	RW	H'00000000	<Base_NS0>+H'05C4	<Base_S0>+H'05C4	32
	Next0 Transaction Byte Register 15/15S	N0TB_15	N0TB_15S	RW	H'00000000	<Base_NS0>+H'05C8	<Base_S0>+H'05C8	32
	Next1 Source Address Register 15/15S	N1SA_15	N1SA_15S	RW	H'00000000	<Base_NS0>+H'05CC	<Base_S0>+H'05CC	32

Table 14.1 Register Configuration (11/11)

Channel	Register Name	Abbreviation		R/W	Initial Value	Address		Access Size
		Non-secure	Secure			Non-secure	Secure	
15	Next1 Destination Address Register 15/15S	N1DA_15	N1DA_15S	RW	H'00000000	<Base_NS0>+H'05D0	<Base_S0>+H'05D0	32
	Next1 Transaction Byte Register 15/15S	N1TB_15	N1TB_15S	RW	H'00000000	<Base_NS0>+H'05D4	<Base_S0>+H'05D4	32
	Current Source Address Register 15/15S	CRSA_15	CRSA_15S	R	H'00000000	<Base_NS0>+H'05D8	<Base_S0>+H'05D8	32
	Current Destination Address Register 15/15S	CRDA_15	CRDA_15S	R	H'00000000	<Base_NS0>+H'05DC	<Base_S0>+H'05DC	32
	Current Transaction Byte Register 15/15S	CRTB_15	CRTB_15S	R	H'00000000	<Base_NS0>+H'05E0	<Base_S0>+H'05E0	32
	Channel Status Register 15/15S	CHSTAT_15	CHSTAT_15S	R	H'00000000	<Base_NS0>+H'05E4	<Base_S0>+H'05E4	32
	Channel Control Register 15/15S	CHCTRL_15	CHCTRL_15S	RW	H'00000000	<Base_NS0>+H'05E8	<Base_S0>+H'05E8	32
	Channel Configuration Register 15/15S	CHCFG_15	CHCFG_15S	RW	H'00000000	<Base_NS0>+H'05EC	<Base_S0>+H'05EC	32
	Channel Interval Register 15/15S	CHITVL_15	CHITVL_15S	RW	H'00000000	<Base_NS0>+H'05F0	<Base_S0>+H'05F0	32
	Channel Extension Register 15/15S	CHEXT_15	CHEXT_15S	RW	H'00000000	<Base_NS0>+H'05F4	<Base_S0>+H'05F4	32
	Next Link Address Register 15/15S	NXLA_15	NXLA_15S	RW	H'00000000	<Base_NS0>+H'05F8	<Base_S0>+H'05F8	32
	Current Link Address Register 15/15S	CRLA_15	CRLA_15S	R	H'00000000	<Base_NS0>+H'05FC	<Base_S0>+H'05FC	32
Common for 8 to 15	DMA Control Registers 8-15/8-15S	DCTRL_8_15	DCTRL_8_15S	RW	H'00000000	<Base_NS0>+H'0700	<Base_S0>+H'0700	32
	DMA Status EN Registers 8-15/8-15S	DSTAT_EN_8_15	DSTAT_EN_8_15S	R	H'00000000	<Base_NS0>+H'0710	<Base_S0>+H'0710	32
	DMA Status ER Registers 8-15/8-15S	DSTAT_ER_8_15	DSTAT_ER_8_15S	R	H'00000000	<Base_NS0>+H'0714	<Base_S0>+H'0714	32
	DMA Status END Registers 8-15/8-15S	DSTAT_END_8_15	DSTAT_END_8_15S	R	H'00000000	<Base_NS0>+H'0718	<Base_S0>+H'0718	32
	DMA Status TC Registers 8-15/8-15S	DSTAT_TC_8_15	DSTAT_TC_8_15S	R	H'00000000	<Base_NS0>+H'071C	<Base_S0>+H'071C	32
	DMA Status SUS Registers 8-15/8-15S	DSTAT_SUS_8_15	DSTAT_SUS_8_15S	R	H'00000000	<Base_NS0>+H'0720	<Base_S0>+H'0720	32

(2) APB I/F

Base Address Name	Base Address
<Base_S1>	H'0_1181_0000 (AX45MP Address Space)
<Base_NS1>	H'0_1183_0000 (AX45MP Address Space)

Table 14.2 Register Configuration

Channel	Register Name	Abbreviation		R/W	Initial Value	Address		Access Size
		Non-secure	Secure			Non-secure	Secure	
0/1	DMA Extension Resource Selectors 0/0S	DMARS0	DMARS0S	RW	H'00000000	<Base_NS1> +H'0000	<Base_S1>+ H'0000	32
2/3	DMA Extension Resource Selectors 1/1S	DMARS1	DMARS1S	RW	H'00000000	<Base_NS1> +H'0004	<Base_S1>+ H'0004	32
4/5	DMA Extension Resource Selectors 2/2S	DMARS 2	DMARS 2S	RW	H'00000000	<Base_NS1> +H'0008	<Base_S1>+ H'0008	32
6/7	DMA Extension Resource Selectors 3/3S	DMARS 3	DMARS 3S	RW	H'00000000	<Base_NS1> +H'000C	<Base_S1>+ H'000C	32
8/9	DMA Extension Resource Selectors 4/4S	DMARS 4	DMARS 4S	RW	H'00000000	<Base_NS1> +H'0010	<Base_S1>+ H'0010	32
10/11	DMA Extension Resource Selectors 5/5S	DMARS 5	DMARS 5S	RW	H'00000000	<Base_NS1> +H'0014	<Base_S1>+ H'0014	32
12/13	DMA Extension Resource Selectors 6/6S	DMARS 6	DMARS 6S	RW	H'00000000	<Base_NS1> +H'0018	<Base_S1>+ H'0018	32
14/15	DMA Extension Resource Selectors 7/7S	DMARS 7	DMARS 7S	RW	H'00000000	<Base_NS1> +H'001C	<Base_S1>+ H'001C	32

14.4.1 Next Source Address Register n/nS (N0SA_n/nS, N1SA_n/nS)

This register sets the DMA transfer source address (32 bits) of DMA channel n (n = 0 to 15) which is to be executed next. N0SA_n/nS is for the Next0 Register Set, and N1SA_n/nS is for the Next1 Register Set.

In register mode, set this register set by using software. In link mode, the descriptor read data is automatically set in the Next0 register set.

These register set values are loaded to the Current Register Set and used for DMA transfer.

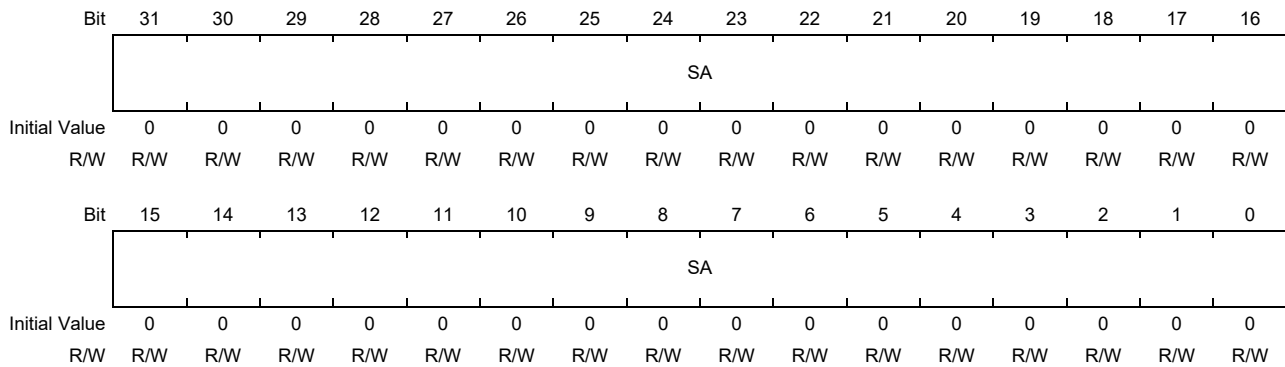

Bit	Bit Name	Initial Value	R/W	Description
31 to 0	SA	All 0	R/W	Source Address Sets the start address of the DMA transfer source.

14.4.2 Next Destination Address Register n/nS (N0DA_n/nS, N1DA_n/nS)

This register sets the DMA transfer destination address (32 bits) of DMA channel n (n = 0 to 15) which is to be executed next.

N0DA_n/nS is for the Next0 Register Set, and N1DA_n/nS is for the Next1 Register Set.

In register mode, set this register set by using software. In link mode, the descriptor read data is automatically set in the Next0 register set.

These register set values are loaded to the Current Register Set and used for DMA transfer.

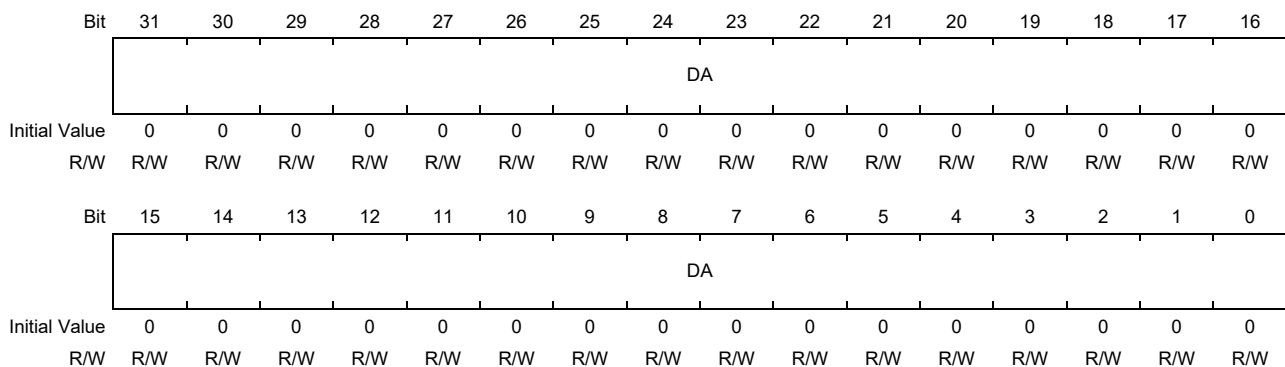

Bit	Bit Name	Initial Value	R/W	Description
31 to 0	DA	All 0	R/W	Destination Address Sets the start address of the DMA transfer destination.

14.4.3 Next Transaction Byte Register n/nS (N0TB_n/nS, N1TB_n/nS)

This register sets the total transfer byte count (DMA transaction) of DMA channel (n = 0 to 15) which is to be executed next.

N0TB_n/nS is for the Next0 Register Set, and N1TB_n/nS is for the Next1 Register Set.

In register mode, set this register set by using software. In link mode, the descriptor read data is automatically set in the Next0 register set.

These register set values are loaded to the Current Register Set and used for DMA transfer.

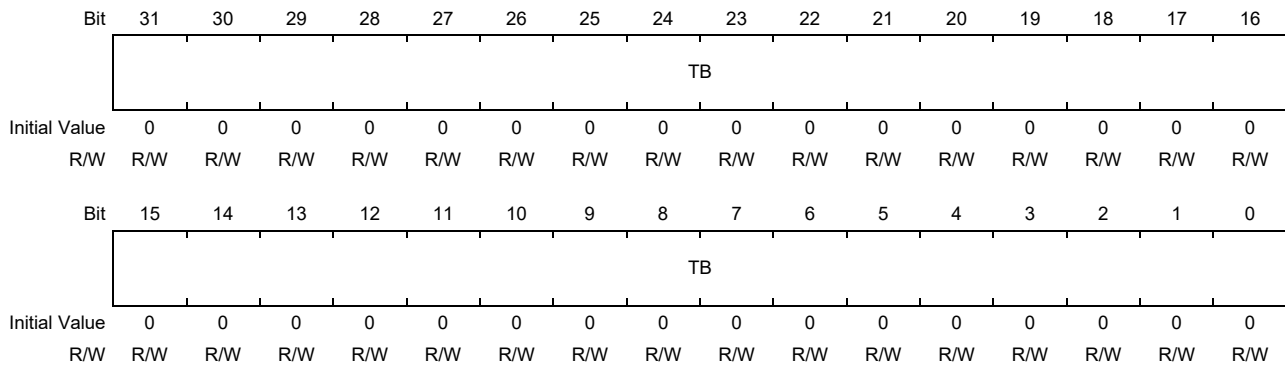

Bit	Bit Name	Initial Value	R/W	Description
31 to 0	TB	All 0	R/W	Transaction Byte Sets the total transfer byte count.

Note: Do not start a DMA transaction with 0 set in this register.

14.4.4 Current Source Address Register n/nS (CRSA_n/nS)

This register indicates the DMA transfer source address of DMA channel n (n = 0 to 15).

The values are loaded from the Next0/1 register set in register mode or from the descriptor read data in link mode. This register cannot be written by software.

Bit	31	30	29	28	27	26	25	24	23	22	21	20	19	18	17	16
	CRSA															
Initial Value	0	0	0	0	0	0	0	0	0	0	0	0	0	0	0	0
R/W	R	R	R	R	R	R	R	R	R	R	R	R	R	R	R	R
Bit	15	14	13	12	11	10	9	8	7	6	5	4	3	2	1	0
	CRSA															
Initial Value	0	0	0	0	0	0	0	0	0	0	0	0	0	0	0	0
R/W	R	R	R	R	R	R	R	R	R	R	R	R	R	R	R	R

Bit	Bit Name	Initial Value	R/W	Description
31 to 0	CRSA	All 0	R	Current Source Address Register Indicates the read address of the next DMA transaction. The value automatically increments during the DMA transaction. (The value is fixed when 1 is set in SAD of the CHCFG_n/nS register.) The value increments when a read transfer starts. Read this register after DMA stops (0 is set in EN of the CHSTAT_n/nS register). (Any value obtained during the DMA operation should be handled as a reference value.)

14.4.5 Current Destination Address Register n/nS (CRDA_n/nS)

This register indicates the DMA transfer destination address of DMA channel n (n = 0 to 15).

The values are loaded from the Next0/1 register set in register mode or from the descriptor read data in link mode. This register cannot be written by software.

Bit	31	30	29	28	27	26	25	24	23	22	21	20	19	18	17	16
	CRDA															
Initial Value	0	0	0	0	0	0	0	0	0	0	0	0	0	0	0	0
R/W	R	R	R	R	R	R	R	R	R	R	R	R	R	R	R	R
Bit	15	14	13	12	11	10	9	8	7	6	5	4	3	2	1	0
	CRDA															
Initial Value	0	0	0	0	0	0	0	0	0	0	0	0	0	0	0	0
R/W	R	R	R	R	R	R	R	R	R	R	R	R	R	R	R	R

Bit	Bit Name	Initial Value	R/W	Description
31 to 0	CRDA	All 0	R	<p>Current Destination Address Register</p> <p>Indicates the write address of the next DMA transaction.</p> <p>The value automatically increments during the DMA transaction. (The value is fixed when 1 is set in DAD of the CHCFG_n/nS register.)</p> <p>The value increments when a write transfer starts.</p> <p>Read this register after DMA stops (0 is set in EN of the CHSTAT_n/nS register). (Any value obtained during the DMA operation should be handled as a reference value.)</p>

14.4.6 Current Transaction Byte Register n/nS (CRTB_n/nS)

This register indicates the total transfer byte count of DMA channel n (n = 0 to 15). The value of this register becomes 0 when the transaction ends.

The values are loaded from the Next0/1 register set in register mode or from the descriptor read data in link mode. This register cannot be written by software.

Bit	31	30	29	28	27	26	25	24	23	22	21	20	19	18	17	16
	CRTB															
Initial Value	0	0	0	0	0	0	0	0	0	0	0	0	0	0	0	0
R/W	R	R	R	R	R	R	R	R	R	R	R	R	R	R	R	R
Bit	15	14	13	12	11	10	9	8	7	6	5	4	3	2	1	0
	CRTB															
Initial Value	0	0	0	0	0	0	0	0	0	0	0	0	0	0	0	0
R/W	R	R	R	R	R	R	R	R	R	R	R	R	R	R	R	R

Bit	Bit Name	Initial Value	R/W	Description
31 to 0	CRTB	All 0	R	Current Transaction Byte Register Indicates the remaining transfer byte count of the currently executed DMA transaction. The value automatically decrements during the DMA transaction. The value decrements when a write transfer is completed. Read this register after DMA stops (0 is set in EN of the CHSTAT_n/nS register). (Any value obtained during the DMA operation should be handled as a reference value.)

14.4.7 Channel Status Register n/nS (CHSTAT_n/nS)

This register indicates the status of DMA channel n (n = 0 to 15).

Bit	31	30	29	28	27	26	25	24	23	22	21	20	19	18	17	16
	—	—	—	—	—	—	—	—	—	—	—	—	—	—	—	INTMSK
Initial Value	0	0	0	0	0	0	0	0	0	0	0	0	0	0	0	0
R/W	R	R	R	R	R	R	R	R	R	R	R	R	R	R	R	R
Bit	15	14	13	12	11	10	9	8	7	6	5	4	3	2	1	0
	—	—	—	—	MODE	DER	DW	DL	SR	TC	END	ER	SUS	TACT	RQST	EN
Initial Value	0	0	0	0	0	0	0	0	0	0	0	0	0	0	0	0
R/W	R	R	R	R	R	R	R	R	R	R	R	R	R	R	R	R

Bit	Bit Name	Initial Value	R/W	Description
31 to 17	—	All 0	R	Reserved. Set 0. A read operation results in 0 being read.
16	INTMSK	0	R	Indicates the temporary mask status of the DMA transfer end interrupt. 1: Masked temporarily 0: Unmasked temporarily Set condition(s): • When SETINTMSK (CHCTRL_n/nS) is set to 1 Reset condition(s): • When CLRINTMSK (CHCTRL_n/nS) is set to 1 • When SWRST (CHCTRL_n/nS) is set to 1
15 to 12	—	All 0	R	Reserved. Set 0. A read operation results in 0 being read.
11	MODE	0	R	DMA Mode Indicates the DMA mode. It corresponds to the value set in the DMS bit of the CHCFG_n/nS register. 0: Register mode 1: Link mode
10	DER	0	R	Descriptor Error Indicates whether the link valid value of the read descriptor is invalid (LV = 0) (this is not dependent on the DIM level of the descriptor). If a descriptor error has occurred, the transfer is stopped but no DMA error interrupt occurs. 0: Descriptor Error not detected 1: Descriptor Error detected Set condition(s): • When the LV value loaded with the descriptor in link mode is 0 Reset condition(s): • When SWRST (CHCTRL_n/nS) is set to 1
9	DW	0	R	Descriptor WriteBack Indicates the descriptor writeback status. The bit maintains 1 if a bus error is received during descriptor writeback. 0: Operation other than writeback is being performed for the header in link mode. 1: (ER = 0) Writeback is being performed for the header in link mode. (ER = 1) A bus error occurs during writeback for the header in link mode. Set condition(s): • When header writeback in link mode starts Reset condition(s): • When header writeback in link mode ends with an OK response • When SWRST (CHCTRL_n/nS) is set to 1

Bit	Bit Name	Initial Value	R/W	Description
8	DL	0	R	<p>Descriptor Load</p> <p>Indicates whether the descriptor is being loaded. The bit maintains 1 if a bus error is received during descriptor load.</p> <p>0: Operation other than descriptor load 1: (ER = 0) Descriptor load is in progress in link mode. (ER = 1) A bus error occurs during descriptor load in link mode.</p> <p>Set condition(s):</p> <ul style="list-style-type: none"> • When descriptor load in link mode starts <p>Reset condition(s):</p> <ul style="list-style-type: none"> • When descriptor load in link mode ends with an OK response • When SWRST (CHCTRL_n/nS) is set to 1
7	SR	0	R	<p>Selected Register Set</p> <p>Indicates the register set currently selected in register mode.</p> <p>0: Next0 Register Set 1: Next1 Register Set</p> <p>Set condition(s):</p> <ul style="list-style-type: none"> • When RSEL (CHCFG_n/nS) is set to 1 <p>Reset condition(s):</p> <ul style="list-style-type: none"> • When RSEL (CHCFG_n/nS) is set to 0
6	TC	0	R	<p>Terminal Count</p> <p>Indicates whether the DMA transaction is completed.</p> <p>0: DMA transfer not completed 1: DMA transfer completed</p> <p>Set condition(s):</p> <ul style="list-style-type: none"> • When data equivalent to the total transfer byte count set in the CRTB register has been transferred in register mode • When data equivalent to the total transfer byte count set in the CRTB register has been transferred in link mode, with 1 set in WBD of the descriptor header • When descriptor writeback is completed in link mode, with 0 set in WBD of the descriptor header <p>Clear condition(s):</p> <ul style="list-style-type: none"> • When the CLRTC (CHCTRL_n/nS) bit is set to 1 • When the SWRST (CHCTRL_n/nS) bit is set to 1
5	END	0	R	<p>DMAEND Interrupted</p> <p>Indicates whether the DMA transaction is completed and whether the DMA transfer end interrupt has occurred.</p> <p>0: DMA transfer not completed 1: DMA transfer completed</p> <p>Set condition(s):</p> <ul style="list-style-type: none"> • When one of the set conditions for the TC bit is met and 0 is set in DEM of the CHCFG_n/nS register • When the descriptor is read in link mode and both LV of the header and DIM are set to 0 <p>Clear condition(s):</p> <ul style="list-style-type: none"> • When CLREND (CHCTRL_n/nS) is set to 1 • When SWRST (CHCTRL_n/nS) is set to 1

Bit	Bit Name	Initial Value	R/W	Description
4	ER	0	R	<p>Error bit</p> <p>Indicates that a DMA error interrupt has occurred because an error response has been received from the transfer source or destination and a bus error has occurred during the DMA transfer.</p> <p>0: No bus error has occurred 1: A DMA error interrupt has occurred due to a bus error</p> <p>Set condition(s):</p> <ul style="list-style-type: none"> • When a bus error has occurred during a bus cycle <p>Clear condition(s):</p> <ul style="list-style-type: none"> • When SWRST (CHCTRL_n/nS) is set to 1
3	SUS	0	R	<p>Suspend</p> <p>Indicates whether the channel is suspended.</p> <p>0: Channel_n not suspended 1: Channel_n suspended</p> <p>Set condition(s):</p> <ul style="list-style-type: none"> • When SETSUS (CHCTRL_n/nS) is set to 1 during a DMA transfer on Channel_n, creating a SUSPEND status internally <p>Clear condition(s):</p> <ul style="list-style-type: none"> • When CLRSUS (CHCTRL_n/nS) is set to 1 • When CLREN (CHCTRL_n/nS) is set to 1
2	TACT	0	R	<p>Transaction Active</p> <p>Indicates whether the DMAC is active. This bit is intended to check that the channel is completely inactive.</p> <p>0: DMA on Channel_n inactive 1: DMA on Channel_n active</p> <p>Set condition(s):</p> <ul style="list-style-type: none"> • When a DMA transaction starts on Channel_n <p>Clear condition(s):</p> <ul style="list-style-type: none"> • When a DMA transaction is completed
1	RQST	0	R	<p>Request</p> <p>Indicates whether a transfer request is being received.</p> <p>0: DMA transfer request not being received 1: DMA transfer request being received</p> <p>Set condition(s):</p> <ul style="list-style-type: none"> • When the STG bit (CHCTRL_n/nS) is set to 1 (auto request) • When a transfer request is received from the DMA request source set in the CHCFG_n/nS register <p>Clear condition(s):</p> <ul style="list-style-type: none"> • When SWRST (CHCTRL_n/nS) is set to 1 • When CLRRQ (CHCTRL_n/nS) is set to 1 • When a transfer is executed on the side specified by REQD (CHCFG_n/nS) in single transfer mode (TM = 0). • When all DMA transactions are completed in register mode (the transaction ends with REN set to 0) • When the DMA transfer of the last descriptor (LE = 1) is completed in link mode • When descriptor read stops (LV = 0) in link mode • When a bus error is received due to an error response

Bit	Bit Name	Initial Value	R/W	Description
0	EN	0	R	<p>Enable</p> <p>Indicates whether the operation of DMA channel n is enabled or disabled.</p> <p>0: Operation disabled 1: Operation enabled</p> <p>Set condition(s):</p> <ul style="list-style-type: none"> • When SETEN (CHCTRL_n/nS) is set to 1 <p>Clear condition(s):</p> <ul style="list-style-type: none"> • When SWRST (CHCTRL_n/nS) is set to 1 • When CLREN (CHCTRL_n/nS) is set to 1 • When a bus error is received due to an error response during the transfer • When all DMA transactions are completed in register mode (the transaction ends with REN set to 0) • When the DMA transfer of the last descriptor (LE = 1) is completed in link mode (writeback when WBD is set to 0) • When descriptor read stops (LV = 0) in link mode

CAUTION

If the ER bit is set to 1 for any transfer, the whole transfer should be handled as invalid.

To suspend a DMA transaction, mask or clear the transfer request or clear the Enable bit (for the procedure, see **Section 14.7.8(2), Transfer Stop**).

If a transfer request from an on-chip peripheral module input is made concurrently with an auto request (by setting 1 in the STG bit) for the same one channel, the trigger source that takes effect cannot be identified. Make sure that only one of these transfer requests is used in the system.

When transfer is requested by an auto request, wait for the last requested DMA transfer to complete (use the Current Register or other data to check the status) before setting the STG bit for the next transfer request.

14.4.8 Channel Control Register n/nS (CHCTRL_n/nS)

This register controls the DMA transfer operation on DMA channel n (n = 0 to 15).

Bit	31	30	29	28	27	26	25	24	23	22	21	20	19	18	17	16
	—	—	—	—	—	—	—	—	—	—	—	—	—	—	CLRINT MSK	SETINT MSK
Initial Value	0	0	0	0	0	0	0	0	0	0	0	0	0	0	0	0
R/W	R	R	R	R	R	R	R	R	R	R	R	R	R	R	R/W	R/W
Bit	15	14	13	12	11	10	9	8	7	6	5	4	3	2	1	0
	—	—	—	—	—	—	CLRSU S	SETSUS	—	CLRTC	CLREND	CLRRQ	SWRST	STG	CLREN	SETEN
Initial Value	0	0	0	0	0	0	0	0	0	0	0	0	0	0	0	0
R/W	R	R	R	R	R	R	R/W	R/W	R	R/W	R/W	R/W	R/W	R/W	R/W	R/W

Bit	Bit Name	Initial Value	R/W	Description
31 to 18	—	All 0	R	Reserved. Set 0. A read operation results in 0 being read.
17	CLRINTMSK	0	R/W	When this bit is set to 1, the mask of the DMA transfer end interrupt is cleared. Also, the INTMSK bit of the CHSTAT_n/nS register is set to 0. If the mask is cleared when 1 is set in both LVINT of the DCTRL register and END of the CHSTAT_n/nS register, the DMA transfer end interrupt becomes active. (It does not become active when 0 is set in LVINT.) A read operation results in 0 being read. 1: Clears the mask set by SETINTMSK. 0: Does not affect the operation.
16	SETINTMSK	0	R/W	When this bit is set to 1, the DMA transfer end interrupt is temporarily masked. Also, the INTMSK bit of the CHSTAT_n/nS register is set to 1. A read operation results in 0 being read. 1: Masks the DMA transfer end interrupt. 0: Does not affect the operation.
15 to 10	—	All 0	R	Reserved. Set 0. A read operation results in 0 being read.
9	CLRSUS	0	R/W	Clear Suspend Clears the suspend status. Setting this bit to 1 when 1 is set in SUS of the CHSTAT_n/nS register can clear the suspend status. An attempt to read this bit results in 0 being read. 1: Clears the suspend status of the current DMA transfer. 0: Does not affect the operation.
8	SETSUS	0	R/W	Set Suspend Suspends the current DMA transfer. Setting this bit to 1 when 1 is set in EN of the CHSTAT_n/nS register can suspend the current DMA transfer. An attempt to read this bit results in 0 being read. 1: Suspends the current DMA transfer. 0: Does not affect the operation.
7	—	0	R	Reserved. Set 0. A read operation results in 0 being read.
6	CLRTC	0	R/W	Clear TC bit Setting this bit to 1 can clear the TC bit of the CHSTAT_n/nS register. An attempt to read this bit results in 0 being read. 1: Clears the TC bit. 0: Does not affect the operation.

Bit	Bit Name	Initial Value	R/W	Description
5	CLREND	0	R/W	<p>Clear End bit</p> <p>Setting this bit to 1 can clear the END bit of the CHSTAT_n/nS register. Also, the DMA transfer end interrupt is cleared. An attempt to read this bit results in 0 being read.</p> <p>1: Clears the END bit. 0: Does not affect the operation.</p>
4	CLRRQ	0	R/W	<p>Clear Request bit</p> <p>Setting this bit to 1 can clear the RQST bit of the CHSTAT_n/nS register. An attempt to read this bit results in 0 being read.</p> <p>1: Clears the RQST bit. 0: Does not affect the operation.</p>
3	SWRST	0	R/W	<p>Software Reset</p> <p>Setting this bit to 1 can clear the channel status register (CHSTAT_n/nS). When setting this bit to 1, make sure that both the EN bit and TACT bit are set to 0. An attempt to read this bit results in 0 being read.</p> <p>1: Resets the channel status register. 0: Does not affect the operation.</p>
2	STG	0	R/W	<p>Software Trigger</p> <p>Setting this bit to 1 sets an auto request. If this bit is set at the same time the SWRST bit is set, the clear operation by the SWRST bit takes precedence. An attempt to read this bit results in 0 being read.</p> <p>1: Sets a transfer request triggered by an auto request (sets 1 in the RQST bit). 0: Does not affect the operation.</p>
1	CLREN	0	R/W	<p>Clear Enable</p> <p>Setting this bit to 1 can clear the EN bit (for details, see Section 14.7.8(2), Transfer Stop). An attempt to read this bit results in 0 being read.</p> <p>1: Stops the DMA transfer (clears the EN bit). 0: Does not affect the operation.</p>
0	SETEN	0	R/W	<p>Set Enable</p> <p>Enables a DMA transfer on DMA channel n. If this bit is set at the same time the SWRST bit is set, the clear operation by the SWRST bit takes precedence and the transfer does not start. An attempt to read this bit results in 0 being read.</p> <p>1: Enables a DMA transfer (sets 1 in the EN bit). 0: Does not affect the operation.</p>

14.4.9 Channel Configuration Register n/nS (CHCFG_n/nS)

This register controls the DMA transfer operation on DMA channel n (n = 0 to 15).

Bit	31	30	29	28	27	26	25	24	23	22	21	20	19	18	17	16
	DMS	REN	RSW	RSEL	SBE	—	—	DEM	—	TM	DAD	SAD	DDS[3:0]			
Initial Value	0	0	0	0	0	0	0	0	0	0	0	0	0	0	0	0
R/W	R/W	R/W	R/W	R/W	R/W	R	R	R/W	R	R/W	R/W	R/W	R/W	R/W	R/W	R/W
Bit	15	14	13	12	11	10	9	8	7	6	5	4	3	2	1	0
	SDS[3:0]				—	AM[2:0]		—	LVL	HIEN	LOEN	REQD	SEL[2:0]			
Initial Value	0	0	0	0	0	0	0	0	0	0	0	0	0	0	0	0
R/W	R/W	R/W	R/W	R/W	R	R/W	R/W	R/W	R	R/W	R/W	R/W	R/W	R/W	R/W	R/W

Bit	Bit Name	Initial Value	R/W	Description
31	DMS	0	R/W	DMA Mode Select Sets the DMA mode. 0: Register mode (initial value) 1: Link mode
30	REN	0	R/W	Register Set Enable After a DMA transaction is completed, DMA transfers are continued using the Next register set selected by RSEL. This bit is valid only in register mode. 0: Does not continue DMA transfers. 1: Continues DMA transfers. Set condition(s): <ul style="list-style-type: none"> • When 1 is written to this bit Clear condition(s): <ul style="list-style-type: none"> • When 0 is written to this bit • When a DMA transaction is completed, with REN set to 1
29	RSW	0	R/W	Register Select Switch Inverts RSEL automatically after a DMA transaction is completed. This bit is valid only in register mode. 0: Does not invert RSEL automatically after a DMA transaction (initial value). 1: Inverts RSEL automatically after a DMA transaction.
28	RSEL	0	R/W	Register Set Select Selects the Next register set to be executed next. This bit is valid only in register mode. When RSW is set to 1, this bit is inverted automatically when a DMA transaction is completed. 0: Executes the Next0 Register Set (initial value). 1: Executes the Next1 Register Set. Transition condition(s): <ul style="list-style-type: none"> • When a DMA transaction is completed, with RSW set to 1
27	SBE	0	R/W	Sweep Buffer Enable Selects whether to sweep (write) the data already read into the buffer and stop the DMA transfer if the Enable bit is cleared to 0 during a DMA transaction. The sweep mode is available only when REQD is set to 0. 0: Stops the DMA transfer without sweeping the buffer (initial value). 1: Stops the DMA transfer after sweeping the buffer.
26, 25	—	0	R	Reserved. Set 0. A read operation results in 0 being read.

Bit	Bit Name	Initial Value	R/W	Description																														
24	DEM	0	R/W	<p>DMA Transfer End Interrupt Mask</p> <p>Masks the DMA transfer end interrupt for register mode transfer.</p> <p>If 1 is set in this bit when a DMA transfer end interrupt is output, the DMA transfer end interrupt signal is not asserted. In this case, DEM is cleared to 0 automatically.</p> <p>0: Does not mask the DMA transfer end interrupt (initial value).</p> <p>1: Masks the DMA transfer end interrupt.</p> <p>Clear condition(s):</p> <ul style="list-style-type: none"> When a DMA transaction is completed with DEM set to 1 																														
23	—	0	R	Reserved. Set 0. A read operation results in 0 being read.																														
22	TM	0	R/W	<p>Transfer Mode</p> <p>Sets the DMA transfer mode.</p> <p>0: Single transfer mode (initial value)</p> <p>1: Block transfer mode</p>																														
21	DAD	0	R/W	<p>Sets the destination address counting direction of DMA channel n.</p> <p>0: Increment (initial value)</p> <p>1: Fixed</p>																														
20	SAD	0	R/W	<p>Sets the source address counting direction of DMA channel n.</p> <p>0: Increment (initial value)</p> <p>1: Fixed</p>																														
19 to 16	DDS[3:0]	0000	R/W	<p>Destination Data Size</p> <p>Sets the DMA transfer size of the transfer destination.</p> <table border="1"> <thead> <tr> <th>Value</th> <th>Size</th> <th>Remark</th> </tr> </thead> <tbody> <tr> <td>0000</td> <td>8 bits</td> <td>Initial value</td> </tr> <tr> <td>0001</td> <td>16 bits</td> <td></td> </tr> <tr> <td>0010</td> <td>32 bits</td> <td></td> </tr> <tr> <td>0011</td> <td>64 bits</td> <td></td> </tr> <tr> <td>0100</td> <td>128 bits</td> <td></td> </tr> <tr> <td>0101</td> <td>256 bits</td> <td></td> </tr> <tr> <td>0110</td> <td>512 bits</td> <td></td> </tr> <tr> <td>0111</td> <td>1024 bits</td> <td></td> </tr> <tr> <td>Other than the above</td> <td>—</td> <td>Setting prohibited</td> </tr> </tbody> </table>	Value	Size	Remark	0000	8 bits	Initial value	0001	16 bits		0010	32 bits		0011	64 bits		0100	128 bits		0101	256 bits		0110	512 bits		0111	1024 bits		Other than the above	—	Setting prohibited
Value	Size	Remark																																
0000	8 bits	Initial value																																
0001	16 bits																																	
0010	32 bits																																	
0011	64 bits																																	
0100	128 bits																																	
0101	256 bits																																	
0110	512 bits																																	
0111	1024 bits																																	
Other than the above	—	Setting prohibited																																
15 to 12	SDS[3:0]	0000	R/W	<p>Source Data Size</p> <p>Sets the DMA transfer size of the transfer source.</p> <table border="1"> <thead> <tr> <th>Value</th> <th>Size</th> <th>Remark</th> </tr> </thead> <tbody> <tr> <td>0000</td> <td>8 bits</td> <td>Initial value</td> </tr> <tr> <td>0001</td> <td>16 bits</td> <td></td> </tr> <tr> <td>0010</td> <td>32 bits</td> <td></td> </tr> <tr> <td>0011</td> <td>64 bits</td> <td></td> </tr> <tr> <td>0100</td> <td>128 bits</td> <td></td> </tr> <tr> <td>0101</td> <td>256 bits</td> <td></td> </tr> <tr> <td>0110</td> <td>512 bits</td> <td></td> </tr> <tr> <td>0111</td> <td>1024 bits</td> <td></td> </tr> <tr> <td>Other than the above</td> <td>—</td> <td>Setting prohibited</td> </tr> </tbody> </table>	Value	Size	Remark	0000	8 bits	Initial value	0001	16 bits		0010	32 bits		0011	64 bits		0100	128 bits		0101	256 bits		0110	512 bits		0111	1024 bits		Other than the above	—	Setting prohibited
Value	Size	Remark																																
0000	8 bits	Initial value																																
0001	16 bits																																	
0010	32 bits																																	
0011	64 bits																																	
0100	128 bits																																	
0101	256 bits																																	
0110	512 bits																																	
0111	1024 bits																																	
Other than the above	—	Setting prohibited																																
11	—	0	R	Reserved. Set 0. A read operation results in 0 being read.																														

Bit	Bit Name	Initial Value	R/W	Description
10 to 8	AM[2:0]	000	R/W	<p>ACK Mode</p> <p>Sets the DMAACK output mode.</p> <p>In case of Auto-Request Mode, DMAACK is not output. Any value can be set in AM bit.</p> <p>In case of On-Chip Peripheral Module Request Mode, see Table 14.3 and set the appropriate value.</p> <p>000: Not used.</p> <p>001: Level mode (active until the transfer request from an on-chip peripheral module input becomes inactive)</p> <p>01x: Bus cycle mode (active while the DMA transfer is in a bus cycle)</p> <p>1xx: DMAACK not to be output</p>
7	—	0	R	Reserved. Set 0. A read operation results in 0 being read.
6	LVL	0	R/W	<p>Level</p> <p>Selects whether to detect a DMA request based on the level or edge of the signal.</p> <p>0: Detects based on the edge (initial value).</p> <p>1: Detects based on the level.</p>
5	HIEN	0	R/W	<p>High Enable</p> <p>Selects whether to detect a DMA request using the High level or rising edge of the signal.</p> <p>When LVL = 0:</p> <p>HIEN = 1: Detects a request in response to the rising edge of the signal.</p> <p>HIEN = 0: Does not detect a request in response to the rising edge of the signal (initial value).</p> <p>When LVL = 1:</p> <p>HIEN = 1: Detects a request when the signal is at the High level.</p> <p>HIEN = 0: Does not detect a request even when the signal is at the High level (initial value).</p>
4	LOEN	0	R/W	<p>Low Enable</p> <p>Selects whether to detect a DMA request using the Low level or falling edge of the signal.</p> <p>When LVL = 0:</p> <p>LOEN = 1: Detects a request in response to the falling edge of the signal.</p> <p>LOEN = 0: Does not detect a request in response to the falling edge of the signal (initial value).</p> <p>When LVL = 1:</p> <p>LOEN = 1: Detects a request when the signal is at the Low level.</p> <p>LOEN = 0: Does not detect a request even when the signal is at the Low level (initial value).</p>
3	REQD	0	R/W	<p>Request Direction</p> <p>Selects whether DMAREQ selected by the SEL bit is the source or destination. This bit is also used to define when DMAACK is to become active.</p> <p>0: Source; DMAACK is to become active when read (initial value).</p> <p>1: Destination; DMAACK is to become active when written.</p>
2 to 0	SEL[2:0]	000	R/W	<p>These bits are used to set a DMAC channel. Set one of the following values so that the channel set by the SEL bits matches the CHCFG_n/nS channel.</p> <p>000: CH0/CH8</p> <p>001: CH1/CH9</p> <p>010: CH2/CH10</p> <p>011: CH3/CH11</p> <p>100: CH4/CH12</p> <p>101: CH5/CH13</p> <p>110: CH6/CH14</p> <p>111: CH7/CH15</p>

14.4.10 Channel Interval Register n/nS (CHITVL_n/nS)

This register sets the transfer interval for DMA channel n (n = 0 to 15).

For details, see **Section 14.7.6, Interval Count Function**.

Bit	31	30	29	28	27	26	25	24	23	22	21	20	19	18	17	16
	—	—	—	—	—	—	—	—	—	—	—	—	—	—	—	—
Initial Value	0	0	0	0	0	0	0	0	0	0	0	0	0	0	0	0
R/W	R	R	R	R	R	R	R	R	R	R	R	R	R	R	R	R
Bit	15	14	13	12	11	10	9	8	7	6	5	4	3	2	1	0
	ITVL															
Initial Value	0	0	0	0	0	0	0	0	0	0	0	0	0	0	0	0
R/W	R/W	R/W	R/W	R/W	R/W	R/W	R/W	R/W	R/W	R/W	R/W	R/W	R/W	R/W	R/W	R/W

Bit	Bit Name	Initial Value	R/W	Description
31 to 16	—	All 0	R	Reserved. Set 0. A read operation results in 0 being read.
15 to 0	ITVL	All 0	R/W	Sets the channel transfer interval.

14.4.11 Channel Extension Register n/nS (CHEXT_n/nS)

This is an extension register for DMA channel n (n = 0 to 15).

Bit	31	30	29	28	27	26	25	24	23	22	21	20	19	18	17	16
	—	—	—	—	—	—	—	—	—	—	—	—	—	—	—	—
Initial Value	0	0	0	0	0	0	0	0	0	0	0	0	0	0	0	0
R/W	R	R	R	R	R	R	R	R	R	R	R	R	R	R	R	R
Bit	15	14	13	12	11	10	9	8	7	6	5	4	3	2	1	0
	DCA[3:0]				—	DPR[2:0]			SCA[3:0]				—	SPR[2:0]		
Initial Value	0	0	0	0	0	0	0	0	0	0	0	0	0	0	0	0
R/W	R/W	R/W	R/W	R/W	R	R/W	R/W	R/W	R/W	R/W	R/W	R/W	R	R/W	R/W	R/W

Bit	Bit Name	Initial Value	R/W	Description
31 to 16	—	All 0	R	Set 0. A read operation results in 0 being read.
15 to 12	DCA[3:0]	0000	R/W	Destination CACHE Sets the value to be output to AWCACHE[3:0] for DMA write transfer. See Note 1 below.
11	—	0	R	Set 0. A read operation results in 0 being read.
10 to 8	DPR[2:0]	000	R/W	Destination PROT Sets the value to be output to AWPROT[2:0] for DMA write transfer. In the case of non-secure access, the value output as AWPROT[1] is fixed to 1 regardless of the setting of the DPR[1] bit. See Note 2 below.
7 to 4	SCA[3:0]	0000	R/W	Source CACHE Sets the value to be output to ARCACHE[3:0] for DMA read transfer. See Note 1 below.
3	—	0	R	Set 0. A read operation results in 0 being read.
2 to 0	SPR[2:0]	000	R/W	Source PROT Sets the value to be output to ARPROT[2:0] for DMA read transfer. In the case of non-secure access, the value output as ARPROT[1] is fixed to 1 regardless of the setting of the SPR[1] bit. See Note 2 below.

Note 1. Cache support: Bits SCA and DCA are used to change the settings.

Note 2. Protection unit support: Bits SPR and DPR are used to change the settings.
For the setting value, see AMBA AXI Protocol Specification from Arm Limited.

14.4.12 Next Link Address Register n/nS (NXLA_n/nS)

This is a 32-bit register that sets the link address of DMA channel n (n = 0 to 15).

For information about the link mode, see **Section 14.6.3, Link Mode**.

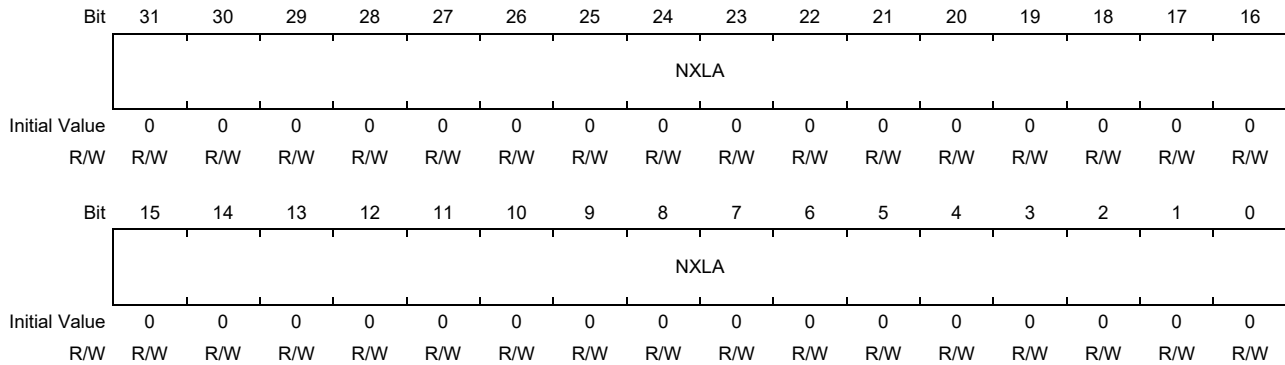

Bit	Bit Name	Initial Value	R/W	Description
31 to 0	NXLA	All 0	R/W	Sets a link address. The low-order 2 bits are masked with 0s. Only an address aligned with a 4-byte boundary can be set.

14.4.13 Current Link Address Register n/nS (CRLA_n/nS)

This is a 32-bit register that indicates the link address of DMA channel n (n = 0 to 15).

For information about the link mode, see **Section 14.6.3, Link Mode**.

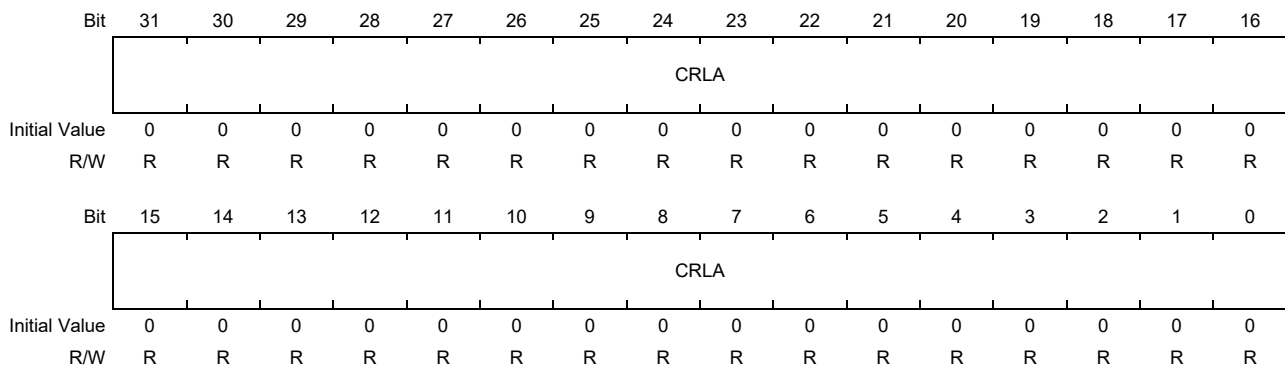

Bit	Bit Name	Initial Value	R/W	Description
31 to 0	CRLA	All 0	R	Indicates the address of the currently executed descriptor.

14.4.14 DMA Control Register (DCTRL_0_7/0_7S, DCTRL_8_15/8_15S)

This register sets the transfer type for descriptor access and the arbitration between channels.

(DCTRL_0_7/0_7S is common for channels 0 to 7 and DCTRL_8_15/8_15S is common for channels 8 to 15.)

Bit	31	30	29	28	27	26	25	24	23	22	21	20	19	18	17	16
	LWCA				—	LWPR			LDCA				—	LDPR		
Initial Value	0	0	0	0	0	0	0	0	0	0	0	0	0	0	0	0
R/W	R/W	R/W	R/W	R/W	R	R/W	R/W	R/W	R/W	R/W	R/W	R/W	R	R/W	R/W	R/W
Bit	15	14	13	12	11	10	9	8	7	6	5	4	3	2	1	0
	—	—	—	—	—	—	—	—	—	—	—	—	—	—	LVINT	PR
Initial Value	0	0	0	0	0	0	0	0	0	0	0	0	0	0	0	0
R/W	R	R	R	R	R	R	R	R	R	R	R	R	R	R	R/W	R/W

Bit	Bit Name	Initial Value	R/W	Description
31 to 28	LWCA	0000	R/W	Link WriteBack CACHE Sets the value to be output to AWCACHE[3:0] during descriptor writeback in link mode. For the setting value, see Note in Section 14.4.11, Channel Extension Register n/nS (CHEXT_n/nS) .
27	—	0	R	Reserved. Set 0. The initial value is 0.
26 to 24	LWPR	000	R/W	Link WriteBack PROT Sets the value to be output to AWPROT[2:0] during descriptor writeback in link mode. In the case of non-secure access, the value output as AWPROT[1] is fixed to 1 regardless of the setting of the LWPR[1] bit. For the setting value, see AMBA AXI Protocol Specification from Arm Limited.
23 to 20	LDCA	0000	R/W	Link Descriptor CACHE Sets the value to be output to ARCACHE[3:0] during descriptor load in link mode. For the setting value, see Note in Section 14.4.11, Channel Extension Register n/nS (CHEXT_n/nS) .
19	—	0	R	Reserved. Set 0. The initial value is 0.
18 to 16	LDPR	000	R/W	Link Descriptor PROT Sets the value to be output to ARPROT[2:0] during descriptor load in link mode. In the case of non-secure access, the value output as ARPROT[1] is fixed to 1 regardless of the setting of the LDPR[1] bit. For the setting value, see AMBA AXI Protocol Specification from Arm Limited.
15 to 2	—	All 0	R	Reserved. Set 0. A read operation results in 0 being read.
1	LVINT	0	R/W	Sets whether to use pulse output or level output for the DMA transfer end interrupt and DMA error interrupt. Set pulse output for this product. 0: Pulse output (initial value) 1: Level output
0	PR	0	R/W	Sets the transfer priority control mode between channels (see Section 14.7.2, Priority Control for DMA Channels). 0: Fixed priority mode (initial value) 1: Round robin mode

14.4.15 DMA Status EN Register (DSTAT_EN_0_7/0_7S)

This register indicates the EN bit status of the CHSTAT_n/nS register (n = 0 to 7).

Writing to this register does not affect the values of the bits.

Bit	31	30	29	28	27	26	25	24	23	22	21	20	19	18	17	16
	—	—	—	—	—	—	—	—	—	—	—	—	—	—	—	—
Initial Value	0	0	0	0	0	0	0	0	0	0	0	0	0	0	0	0
R/W	R	R	R	R	R	R	R	R	R	R	R	R	R	R	R	R
Bit	15	14	13	12	11	10	9	8	7	6	5	4	3	2	1	0
	—	—	—	—	—	—	—	—	EN7	EN6	EN5	EN4	EN3	EN2	EN1	EN0
Initial Value	0	0	0	0	0	0	0	0	0	0	0	0	0	0	0	0
R/W	R	R	R	R	R	R	R	R	R	R	R	R	R	R	R	R

Bit	Bit Name	Initial Value	R/W	Description
31 to 8	—	All 0	R	Reserved. Set 0. A read operation results in 0 being read.
7	EN7	0	R	Indicates the EN bit status of DMA channel 7.
6	EN6	0	R	Indicates the EN bit status of DMA channel 6.
5	EN5	0	R	Indicates the EN bit status of DMA channel 5.
4	EN4	0	R	Indicates the EN bit status of DMA channel 4.
3	EN3	0	R	Indicates the EN bit status of DMA channel 3.
2	EN2	0	R	Indicates the EN bit status of DMA channel 2.
1	EN1	0	R	Indicates the EN bit status of DMA channel 1.
0	EN0	0	R	Indicates the EN bit status of DMA channel 0.

14.4.16 DMA Status EN Register (DSTAT_EN_8_15/8_15S)

This register indicates the EN bit status of the CHSTAT_n/nS register (n = 8 to 15).

Writing to this register does not affect the values of the bits.

Bit	31	30	29	28	27	26	25	24	23	22	21	20	19	18	17	16
	—	—	—	—	—	—	—	—	—	—	—	—	—	—	—	—
Initial Value	0	0	0	0	0	0	0	0	0	0	0	0	0	0	0	0
R/W	R	R	R	R	R	R	R	R	R	R	R	R	R	R	R	R
Bit	15	14	13	12	11	10	9	8	7	6	5	4	3	2	1	0
	—	—	—	—	—	—	—	—	EN15	EN14	EN13	EN12	EN11	EN10	EN9	EN8
Initial Value	0	0	0	0	0	0	0	0	0	0	0	0	0	0	0	0
R/W	R	R	R	R	R	R	R	R	R	R	R	R	R	R	R	R

Bit	Bit Name	Initial Value	R/W	Description
31 to 8	—	All 0	R	Reserved. Set 0. A read operation results in 0 being read.
7	EN15	0	R	Indicates the EN bit status of DMA channel 15.
6	EN14	0	R	Indicates the EN bit status of DMA channel 14.
5	EN13	0	R	Indicates the EN bit status of DMA channel 13.
4	EN12	0	R	Indicates the EN bit status of DMA channel 12.
3	EN11	0	R	Indicates the EN bit status of DMA channel 11.
2	EN10	0	R	Indicates the EN bit status of DMA channel 10.
1	EN9	0	R	Indicates the EN bit status of DMA channel 9.
0	EN8	0	R	Indicates the EN bit status of DMA channel 8.

14.4.17 DMA Status ER Register (DSTAT_ER_0_7/0_7S)

This register indicates the ER bit status of the CHSTAT_n/nS register (n = 0 to 7).

Writing to this register does not affect the values of the bits.

Bit	31	30	29	28	27	26	25	24	23	22	21	20	19	18	17	16
	—	—	—	—	—	—	—	—	—	—	—	—	—	—	—	—
Initial Value	0	0	0	0	0	0	0	0	0	0	0	0	0	0	0	0
R/W	R	R	R	R	R	R	R	R	R	R	R	R	R	R	R	R
Bit	15	14	13	12	11	10	9	8	7	6	5	4	3	2	1	0
	—	—	—	—	—	—	—	—	ER7	ER6	ER5	ER4	ER3	ER2	ER1	ER0
Initial Value	0	0	0	0	0	0	0	0	0	0	0	0	0	0	0	0
R/W	R	R	R	R	R	R	R	R	R	R	R	R	R	R	R	R

Bit	Bit Name	Initial Value	R/W	Description
31 to 8	—	All 0	R	Reserved. Set 0. A read operation results in 0 being read.
7	ER7	0	R	Indicates the ER bit status of DMA channel 7.
6	ER6	0	R	Indicates the ER bit status of DMA channel 6.
5	ER5	0	R	Indicates the ER bit status of DMA channel 5.
4	ER4	0	R	Indicates the ER bit status of DMA channel 4.
3	ER3	0	R	Indicates the ER bit status of DMA channel 3.
2	ER2	0	R	Indicates the ER bit status of DMA channel 2.
1	ER1	0	R	Indicates the ER bit status of DMA channel 1.
0	ER0	0	R	Indicates the ER bit status of DMA channel 0.

14.4.18 DMA Status ER Register (DSTAT_ER_8_15/8_15S)

This register indicates the ER bit status of the CHSTAT_n/nS register (n = 8 to 15).

Writing to this register does not affect the values of the bits.

Bit	31	30	29	28	27	26	25	24	23	22	21	20	19	18	17	16
	—	—	—	—	—	—	—	—	—	—	—	—	—	—	—	—
Initial Value	0	0	0	0	0	0	0	0	0	0	0	0	0	0	0	0
R/W	R	R	R	R	R	R	R	R	R	R	R	R	R	R	R	R
Bit	15	14	13	12	11	10	9	8	7	6	5	4	3	2	1	0
	—	—	—	—	—	—	—	—	ER15	ER14	ER13	ER12	ER11	ER10	ER9	ER8
Initial Value	0	0	0	0	0	0	0	0	0	0	0	0	0	0	0	0
R/W	R	R	R	R	R	R	R	R	R	R	R	R	R	R	R	R

Bit	Bit Name	Initial Value	R/W	Description
31 to 8	—	All 0	R	Reserved. Set 0. A read operation results in 0 being read.
7	ER15	0	R	Indicates the ER bit status of DMA channel 15.
6	ER14	0	R	Indicates the ER bit status of DMA channel 14.
5	ER13	0	R	Indicates the ER bit status of DMA channel 13.
4	ER12	0	R	Indicates the ER bit status of DMA channel 12.
3	ER11	0	R	Indicates the ER bit status of DMA channel 11.
2	ER10	0	R	Indicates the ER bit status of DMA channel 10.
1	ER9	0	R	Indicates the ER bit status of DMA channel 9.
0	ER8	0	R	Indicates the ER bit status of DMA channel 8.

14.4.19 DMA Status END Register (DSTAT_END_0_7/0_7S)

This register indicates the END bit status of the CHSTAT_n/nS register (n = 0 to 7).

Writing to this register does not affect the values of the bits.

Bit	31	30	29	28	27	26	25	24	23	22	21	20	19	18	17	16
	—	—	—	—	—	—	—	—	—	—	—	—	—	—	—	—
Initial Value	0	0	0	0	0	0	0	0	0	0	0	0	0	0	0	0
R/W	R	R	R	R	R	R	R	R	R	R	R	R	R	R	R	R
Bit	15	14	13	12	11	10	9	8	7	6	5	4	3	2	1	0
	—	—	—	—	—	—	—	—	END7	END6	END5	END4	END3	END2	END1	END0
Initial Value	0	0	0	0	0	0	0	0	0	0	0	0	0	0	0	0
R/W	R	R	R	R	R	R	R	R	R	R	R	R	R	R	R	R

Bit	Bit Name	Initial Value	R/W	Description
31 to 8	—	All 0	R	Reserved. Set 0. A read operation results in 0 being read.
7	END7	0	R	Indicates the END bit status of DMA channel 7.
6	END6	0	R	Indicates the END bit status of DMA channel 6.
5	END5	0	R	Indicates the END bit status of DMA channel 5.
4	END4	0	R	Indicates the END bit status of DMA channel 4.
3	END3	0	R	Indicates the END bit status of DMA channel 3.
2	END2	0	R	Indicates the END bit status of DMA channel 2.
1	END1	0	R	Indicates the END bit status of DMA channel 1.
0	END0	0	R	Indicates the END bit status of DMA channel 0.

14.4.20 DMA Status END Register (DSTAT_END_8_15/8_15S)

This register indicates the END bit status of the CHSTAT_n/nS register (n = 8 to 15).

Writing to this register does not affect the values of the bits.

Bit	31	30	29	28	27	26	25	24	23	22	21	20	19	18	17	16
	—	—	—	—	—	—	—	—	—	—	—	—	—	—	—	—
Initial Value	0	0	0	0	0	0	0	0	0	0	0	0	0	0	0	0
R/W	R	R	R	R	R	R	R	R	R	R	R	R	R	R	R	R
Bit	15	14	13	12	11	10	9	8	7	6	5	4	3	2	1	0
	—	—	—	—	—	—	—	—	END15	END14	END13	END12	END11	END10	END9	END8
Initial Value	0	0	0	0	0	0	0	0	0	0	0	0	0	0	0	0
R/W	R	R	R	R	R	R	R	R	R	R	R	R	R	R	R	R

Bit	Bit Name	Initial Value	R/W	Description
31 to 8	—	All 0	R	Reserved. Set 0. A read operation results in 0 being read.
7	END15	0	R	Indicates the END bit status of DMA channel 15.
6	END14	0	R	Indicates the END bit status of DMA channel 14.
5	END13	0	R	Indicates the END bit status of DMA channel 13.
4	END12	0	R	Indicates the END bit status of DMA channel 12.
3	END11	0	R	Indicates the END bit status of DMA channel 11.
2	END10	0	R	Indicates the END bit status of DMA channel 10.
1	END9	0	R	Indicates the END bit status of DMA channel 9.
0	END8	0	R	Indicates the END bit status of DMA channel 8.

14.4.21 DMA Status TC Register (DSTAT_TC_0_7/0_7S)

This register indicates the TC bit status of the CHSTAT_n/nS register (n = 0 to 7).

Writing to this register does not affect the values of the bits.

Bit	31	30	29	28	27	26	25	24	23	22	21	20	19	18	17	16
	—	—	—	—	—	—	—	—	—	—	—	—	—	—	—	—
Initial Value	0	0	0	0	0	0	0	0	0	0	0	0	0	0	0	0
R/W	R	R	R	R	R	R	R	R	R	R	R	R	R	R	R	R
Bit	15	14	13	12	11	10	9	8	7	6	5	4	3	2	1	0
	—	—	—	—	—	—	—	—	TC7	TC6	TC5	TC4	TC3	TC2	TC1	TC0
Initial Value	0	0	0	0	0	0	0	0	0	0	0	0	0	0	0	0
R/W	R	R	R	R	R	R	R	R	R	R	R	R	R	R	R	R

Bit	Bit Name	Initial Value	R/W	Description
31 to 8	—	All 0	R	Reserved. Set 0. A read operation results in 0 being read.
7	TC7	0	R	Indicates the TC bit status of DMA channel 7.
6	TC6	0	R	Indicates the TC bit status of DMA channel 6.
5	TC5	0	R	Indicates the TC bit status of DMA channel 5.
4	TC4	0	R	Indicates the TC bit status of DMA channel 4.
3	TC3	0	R	Indicates the TC bit status of DMA channel 3.
2	TC2	0	R	Indicates the TC bit status of DMA channel 2.
1	TC1	0	R	Indicates the TC bit status of DMA channel 1.
0	TC0	0	R	Indicates the TC bit status of DMA channel 0.

14.4.22 DMA Status TC Register (DSTAT_TC_8_15/8_15S)

This register indicates the TC bit status of the CHSTAT_n/nS register (n = 8 to 15).

Writing to this register does not affect the values of the bits.

Bit	31	30	29	28	27	26	25	24	23	22	21	20	19	18	17	16
	—	—	—	—	—	—	—	—	—	—	—	—	—	—	—	—
Initial Value	0	0	0	0	0	0	0	0	0	0	0	0	0	0	0	0
R/W	R	R	R	R	R	R	R	R	R	R	R	R	R	R	R	R
Bit	15	14	13	12	11	10	9	8	7	6	5	4	3	2	1	0
	—	—	—	—	—	—	—	—	TC15	TC14	TC13	TC12	TC11	TC10	TC9	TC8
Initial Value	0	0	0	0	0	0	0	0	0	0	0	0	0	0	0	0
R/W	R	R	R	R	R	R	R	R	R	R	R	R	R	R	R	R

Bit	Bit Name	Initial Value	R/W	Description
31 to 8	—	All 0	R	Reserved. Set 0. A read operation results in 0 being read.
7	TC15	0	R	Indicates the TC bit status of DMA channel 15.
6	TC14	0	R	Indicates the TC bit status of DMA channel 14.
5	TC13	0	R	Indicates the TC bit status of DMA channel 13.
4	TC12	0	R	Indicates the TC bit status of DMA channel 12.
3	TC11	0	R	Indicates the TC bit status of DMA channel 11.
2	TC10	0	R	Indicates the TC bit status of DMA channel 10.
1	TC9	0	R	Indicates the TC bit status of DMA channel 9.
0	TC8	0	R	Indicates the TC bit status of DMA channel 8.

14.4.23 DMA Status SUS Register (DSTAT_SUS_0_7/0_7S)

This register indicates the SUS bit status of the CHSTAT_n/nS register (n = 0 to 7).

Writing to this register does not affect the values of the bits.

Bit	31	30	29	28	27	26	25	24	23	22	21	20	19	18	17	16
	—	—	—	—	—	—	—	—	—	—	—	—	—	—	—	—
Initial Value	0	0	0	0	0	0	0	0	0	0	0	0	0	0	0	0
R/W	R	R	R	R	R	R	R	R	R	R	R	R	R	R	R	R
Bit	15	14	13	12	11	10	9	8	7	6	5	4	3	2	1	0
	—	—	—	—	—	—	—	—	SUS7	SUS6	SUS5	SUS4	SUS3	SUS2	SUS1	SUS0
Initial Value	0	0	0	0	0	0	0	0	0	0	0	0	0	0	0	0
R/W	R	R	R	R	R	R	R	R	R	R	R	R	R	R	R	R

Bit	Bit Name	Initial Value	R/W	Description
31 to 8	—	All 0	R	Reserved. Set 0. A read operation results in 0 being read.
7	SUS7	0	R	Indicates the SUS bit status of DMA channel 7.
6	SUS6	0	R	Indicates the SUS bit status of DMA channel 6.
5	SUS5	0	R	Indicates the SUS bit status of DMA channel 5.
4	SUS4	0	R	Indicates the SUS bit status of DMA channel 4.
3	SUS3	0	R	Indicates the SUS bit status of DMA channel 3.
2	SUS2	0	R	Indicates the SUS bit status of DMA channel 2.
1	SUS1	0	R	Indicates the SUS bit status of DMA channel 1.
0	SUS0	0	R	Indicates the SUS bit status of DMA channel 0.

14.4.24 DMA Status SUS Register (DSTAT_SUS_8_15/8_15S)

This register indicates the SUS bit status of the CHSTAT_n/nS register (n = 8 to 15).

Writing to this register does not affect the values of the bits.

Bit	31	30	29	28	27	26	25	24	23	22	21	20	19	18	17	16
	—	—	—	—	—	—	—	—	—	—	—	—	—	—	—	—
Initial Value	0	0	0	0	0	0	0	0	0	0	0	0	0	0	0	0
R/W	R	R	R	R	R	R	R	R	R	R	R	R	R	R	R	R
Bit	15	14	13	12	11	10	9	8	7	6	5	4	3	2	1	0
	—	—	—	—	—	—	—	—	SUS15	SUS14	SUS13	SUS12	SUS11	SUS10	SUS9	SUS8
Initial Value	0	0	0	0	0	0	0	0	0	0	0	0	0	0	0	0
R/W	R	R	R	R	R	R	R	R	R	R	R	R	R	R	R	R

Bit	Bit Name	Initial Value	R/W	Description
31 to 8	—	All 0	R	Reserved. Set 0. A read operation results in 0 being read.
7	SUS15	0	R	Indicates the SUS bit status of DMA channel 15.
6	SUS14	0	R	Indicates the SUS bit status of DMA channel 14.
5	SUS13	0	R	Indicates the SUS bit status of DMA channel 13.
4	SUS12	0	R	Indicates the SUS bit status of DMA channel 12.
3	SUS11	0	R	Indicates the SUS bit status of DMA channel 11.
2	SUS10	0	R	Indicates the SUS bit status of DMA channel 10.
1	SUS9	0	R	Indicates the SUS bit status of DMA channel 9.
0	SUS8	0	R	Indicates the SUS bit status of DMA channel 8.

14.4.25 DMA Extension Resource Selectors 0/0S to 7/7S (DMARS0/0S to DMARS7/7S)

DMARS_n/nS (n = 0 to 7) are 32-bit readable/writable registers that specify the DMA transfer sources from peripheral modules in each channel. DMARS0/0S is for channels 0/0S and 1/1S, DMARS1/1S is for channels 2/2S and 3/3S, and so on.

Table 14.3 shows the specifiable combinations.

Some on-chip peripheral modules in this product use the same signal both for an interrupt request and for a DMA transfer request. If such a module is selected by a DMARS_n/nS register, the signal works as a DMA transfer request signal and interrupt requests to the interrupt controller are masked. To enable the interrupt, clear the setting of DMARS_n/nS (set all MID[7:0] and RID[1:0] to 0). See **Table 14.3** for possible combinations of MID[7:0] and RID[1:0].

• DMARS0/0S

Bit	31	30	29	28	27	26	25	24	23	22	21	20	19	18	17	16		
	—						CH1 MID[7:0]										CH1 RID[1:0]	
Initial Value	0	0	0	0	0	0	0	0	0	0	0	0	0	0	0	0		
R/W	R	R	R	R	R	R	R/W	R/W	R/W	R/W	R/W	R/W	R/W	R/W	R/W	R/W		
Bit	15	14	13	12	11	10	9	8	7	6	5	4	3	2	1	0		
	—						CH0 MID[7:0]										CH0 RID[1:0]	
Initial Value	0	0	0	0	0	0	0	0	0	0	0	0	0	0	0	0		
R/W	R	R	R	R	R	R	R/W	R/W	R/W	R/W	R/W	R/W	R/W	R/W	R/W	R/W		

• DMARS1/1S

Bit	31	30	29	28	27	26	25	24	23	22	21	20	19	18	17	16		
	—						CH3 MID[7:0]										CH3 RID[1:0]	
Initial Value	0	0	0	0	0	0	0	0	0	0	0	0	0	0	0	0		
R/W	R	R	R	R	R	R	R/W	R/W	R/W	R/W	R/W	R/W	R/W	R/W	R/W	R/W		
Bit	15	14	13	12	11	10	9	8	7	6	5	4	3	2	1	0		
	—						CH2 MID[7:0]										CH2 RID[1:0]	
Initial Value	0	0	0	0	0	0	0	0	0	0	0	0	0	0	0	0		
R/W	R	R	R	R	R	R	R/W	R/W	R/W	R/W	R/W	R/W	R/W	R/W	R/W	R/W		

• DMARS2/2S

Bit	31	30	29	28	27	26	25	24	23	22	21	20	19	18	17	16		
	—	—	—	—	—	—	CH5 MID[7:0]										CH5 RID[1:0]	
Initial Value	0	0	0	0	0	0	0	0	0	0	0	0	0	0	0	0	0	
R/W	R	R	R	R	R	R	R/W	R/W	R/W	R/W	R/W	R/W	R/W	R/W	R/W	R/W	R/W	

Bit	15	14	13	12	11	10	9	8	7	6	5	4	3	2	1	0		
	—	—	—	—	—	—	CH4 MID[7:0]										CH4 RID[1:0]	
Initial Value	0	0	0	0	0	0	0	0	0	0	0	0	0	0	0	0		
R/W	R	R	R	R	R	R	R/W	R/W	R/W	R/W	R/W	R/W	R/W	R/W	R/W	R/W		

• DMARS3/3S

Bit	31	30	29	28	27	26	25	24	23	22	21	20	19	18	17	16		
	—	—	—	—	—	—	CH7 MID[7:0]										CH7 RID[1:0]	
Initial Value	0	0	0	0	0	0	0	0	0	0	0	0	0	0	0	0		
R/W	R	R	R	R	R	R	R/W	R/W	R/W	R/W	R/W	R/W	R/W	R/W	R/W	R/W		

Bit	15	14	13	12	11	10	9	8	7	6	5	4	3	2	1	0		
	—	—	—	—	—	—	CH6 MID[7:0]										CH6 RID[1:0]	
Initial Value	0	0	0	0	0	0	0	0	0	0	0	0	0	0	0	0		
R/W	R	R	R	R	R	R	R/W	R/W	R/W	R/W	R/W	R/W	R/W	R/W	R/W	R/W		

• DMARS4/4S

Bit	31	30	29	28	27	26	25	24	23	22	21	20	19	18	17	16		
	—	—	—	—	—	—	CH9 MID[7:0]										CH9 RID[1:0]	
Initial Value	0	0	0	0	0	0	0	0	0	0	0	0	0	0	0	0		
R/W	R	R	R	R	R	R	R/W	R/W	R/W	R/W	R/W	R/W	R/W	R/W	R/W	R/W		

Bit	15	14	13	12	11	10	9	8	7	6	5	4	3	2	1	0		
	—	—	—	—	—	—	CH8 MID[7:0]										CH8 RID[1:0]	
Initial Value	0	0	0	0	0	0	0	0	0	0	0	0	0	0	0	0		
R/W	R	R	R	R	R	R	R/W	R/W	R/W	R/W	R/W	R/W	R/W	R/W	R/W	R/W		

• DMARS5/5S

Bit	31	30	29	28	27	26	25	24	23	22	21	20	19	18	17	16		
	—	—	—	—	—	—	CH11 MID[7:0]										CH11 RID[1:0]	
Initial Value	0	0	0	0	0	0	0	0	0	0	0	0	0	0	0	0		
R/W	R	R	R	R	R	R	R/W	R/W	R/W	R/W	R/W	R/W	R/W	R/W	R/W	R/W		

Bit	15	14	13	12	11	10	9	8	7	6	5	4	3	2	1	0		
	—	—	—	—	—	—	CH10 MID[7:0]										CH10 RID[1:0]	
Initial Value	0	0	0	0	0	0	0	0	0	0	0	0	0	0	0	0		
R/W	R	R	R	R	R	R	R/W	R/W	R/W	R/W	R/W	R/W	R/W	R/W	R/W	R/W		

• DMARS6/6S

Bit	31	30	29	28	27	26	25	24	23	22	21	20	19	18	17	16		
	—	—	—	—	—	—	CH13 MID[7:0]										CH13 RID[1:0]	
Initial Value	0	0	0	0	0	0	0	0	0	0	0	0	0	0	0	0		
R/W	R	R	R	R	R	R	R/W	R/W	R/W	R/W	R/W	R/W	R/W	R/W	R/W	R/W		

Bit	15	14	13	12	11	10	9	8	7	6	5	4	3	2	1	0		
	—	—	—	—	—	—	CH12 MID[7:0]										CH12 RID[1:0]	
Initial Value	0	0	0	0	0	0	0	0	0	0	0	0	0	0	0	0		
R/W	R	R	R	R	R	R	R/W	R/W	R/W	R/W	R/W	R/W	R/W	R/W	R/W	R/W		

• DMARS7/7S

Bit	31	30	29	28	27	26	25	24	23	22	21	20	19	18	17	16		
	—	—	—	—	—	—	CH15 MID[7:0]										CH15 RID[1:0]	
Initial Value	0	0	0	0	0	0	0	0	0	0	0	0	0	0	0	0		
R/W	R	R	R	R	R	R	R/W	R/W	R/W	R/W	R/W	R/W	R/W	R/W	R/W	R/W		

Bit	15	14	13	12	11	10	9	8	7	6	5	4	3	2	1	0		
	—	—	—	—	—	—	CH14 MID[7:0]										CH14 RID[1:0]	
Initial Value	0	0	0	0	0	0	0	0	0	0	0	0	0	0	0	0		
R/W	R	R	R	R	R	R	R/W	R/W	R/W	R/W	R/W	R/W	R/W	R/W	R/W	R/W		

14.5 Operation

When there is a DMA transfer request, the DMAC starts the transfer according to the predetermined channel priority order; when the transfer end conditions are satisfied, it ends the transfer. Transfers can be requested in two modes: auto request, and on-chip peripheral module request.

14.5.1 Transfer Flow

After the next source address register (N0SA_n/nS, N1SA_n/nS), next destination address register (N0DA_n/nS, N1DA_n/nS), next transaction byte register (N0TB_n/nS, N1TB_n/nS), channel control register (CHCTRL_n/nS), channel configuration register (CHCFG_n/nS), channel extension register (CHEXT_n/nS), DMA control register (DCTRL_0_7/0_7S, DCTRL_8_15/8_15S), and DMA extension resource selector (DMARSn/nS) are set for the target transfer conditions, the DMAC transfers data according to the following procedure:

1. Checks to see if transfer is enabled (EN = 0 and TACT = 0 in channel status register).
2. Clears the channel status register (set 1 in the SWRST bit of the channel control register).
3. Enables DMA transfer (set 1 in the SETEN bit of the channel control register).
4. When a transfer request comes and transfer is enabled, the DMAC transfers one transfer unit of data (depending on the DDS[3:0] and SDS[3:0] bit settings). For an auto request, the transfer begins automatically when 1 is set in the STG bit of the channel control register. The CRTB_n/nS value will be decremented by 1 for each transfer.
5. If 0 is set in the REN bit of the channel configuration register when transfer has been completed for the specified count (when CRTB_n/nS reaches 0), transfer ends normally. If the DEM bit of the channel configuration register is set to 0 at this time, a DMA transfer end interrupt is sent to the CPU. If the REN bit is 1 when CRTB_n/nS reaches 0, transfer operations are continued with the values of N0SA_n/nS, N1SA_n/nS, N0DA_n/nS, N1DA_n/nS, N0TB_n/nS, and N1TB_n/nS set by the RSEL bit of the channel configuration register until there are no more transfer requests.
6. When an address error in the DMAC is generated, the transfer is stopped. Transfers are also stopped when 1 is set in the CLREN bit of CHCTRL_n/nS.

14.5.2 DMA Transfer Requests

DMA transfer requests are basically generated in either the data transfer source or destination, but they can also be generated in on-chip peripheral modules that are neither the transfer source nor destination. Transfers can be requested in two modes: auto request, and on-chip peripheral module request. On-chip peripheral module request is selected by the DMARS0/0S to DMARS7/7S registers.

(1) Auto-Request Mode

When there is no transfer request signal from an external source, as in a memory-to-memory transfer or a transfer between memory and an on-chip peripheral module unable to request a transfer, auto-request mode allows the DMAC to automatically generate a transfer request signal internally. When the STG bit in channel control register n is set to 1, the transfer begins so long as the TACT bit in channel status register is 0.

(2) On-Chip Peripheral Module Request Mode

In this mode, the transfer is performed in response to the DMA transfer request signal from an on-chip peripheral module.

When a transfer request signal is sent in on-chip peripheral module request mode while DMA transfer is enabled, the DMA transfer is performed.

The DMA transfer request signals to be sent from on-chip peripheral modules or external pin input are listed in

Table 14.3.

The transfer source or destination is fixed for some on-chip peripheral module requests. For details, see **Table 14.3.**

Table 14.3 On-Chip Module Requests (1/5)

Request Source	DMA Transfer Request Signal	Transfer Source	Transfer Destination	DMARSn/nS		CHCFG_n/nS*1						SEL[2:0]
				MID [7:0]	RID [1:0]	TM	AM [2:0]	LVL	HIEN	LOEN	REQD	
GTM ch0	OSTM0TINT (compare match)	Arbitrary	Arbitrary	0000_1000	11	0/1	010	0	1	0	0/1	CH0:000 CH1:001
GTM ch1	OSTM1TINT (compare match)	Arbitrary	Arbitrary	0000_1001	11	0/1	010	0	1	0	0/1	CH2:010 CH3:011
GTM ch2	OSTM2TINT (compare match)	Arbitrary	Arbitrary	0000_1010	11	0/1	010	0	1	0	0/1	CH4:100 CH5:101
MTU3 ch0	TGIA0 (input capture/compare match)	Arbitrary	Arbitrary	0000_1100	11	0/1	001	0	1	0	0/1	CH6:110 CH7:111 CH8:000
	TGIB0 (input capture/compare match)	Arbitrary	Arbitrary	0000_1101	11	0/1	001	0	1	0	0/1	CH9:001 CH10:010 CH11:011
	TGIC0 (input capture/compare match)	Arbitrary	Arbitrary	0000_1110	11	0/1	001	0	1	0	0/1	CH12:100 CH13:101 CH14:110 CH15:111
	TGID0 (input capture/compare match)	Arbitrary	Arbitrary	0000_1111	11	0/1	001	0	1	0	0/1	
MTU3 ch1	TGIA1 (input capture/compare match)	Arbitrary	Arbitrary	0001_0000	11	0/1	001	0	1	0	0/1	
	TGIB1 (input capture/compare match)	Arbitrary	Arbitrary	0001_0001	11	0/1	001	0	1	0	0/1	
MTU3 ch2	TGIA2 (input capture/compare match)	Arbitrary	Arbitrary	0001_0010	11	0/1	001	0	1	0	0/1	
	TGIB2 (input capture/compare match)	Arbitrary	Arbitrary	0001_0011	11	0/1	001	0	1	0	0/1	
MTU3 ch3	TGIA3 (input capture/compare match)	Arbitrary	Arbitrary	0001_0100	11	0/1	001	0	1	0	0/1	
	TGIB3 (input capture/compare match)	Arbitrary	Arbitrary	0001_0101	11	0/1	001	0	1	0	0/1	
	TGIC3 (input capture/compare match)	Arbitrary	Arbitrary	0001_0110	11	0/1	001	0	1	0	0/1	
	TGID3 (input capture/compare match)	Arbitrary	Arbitrary	0001_0111	11	0/1	001	0	1	0	0/1	
MTU3 ch4	TGIA4 (input capture/compare match)	Arbitrary	Arbitrary	0001_1000	11	0/1	001	0	1	0	0/1	
	TGIB4 (input capture/compare match)	Arbitrary	Arbitrary	0001_1001	11	0/1	001	0	1	0	0/1	
	TGIC4 (input capture/compare match)	Arbitrary	Arbitrary	0001_1010	11	0/1	001	0	1	0	0/1	
	TGID4 (input capture/compare match)	Arbitrary	Arbitrary	0001_1011	11	0/1	001	0	1	0	0/1	

Table 14.3 On-Chip Module Requests (2/5)

DMA Transfer												
Request Source	DMA Transfer Request Signal	Transfer Source	Transfer Destination	DMARSn/nS		CHCFG_n/nS*1						SEL[2:0]
				MID [7:0]	RID [1:0]	TM	AM [2:0]	LVL	HIEN	LOEN	REQD	
MTU3 ch4	TCIV4 (input capture/compare match)	Arbitrary	Arbitrary	0001_1100	11	0/1	001	0	1	0	0/1	CH0:000 CH1:001 CH2:010
MTU3 ch5	TGIU5 (input capture/compare match)	Arbitrary	Arbitrary	0001_1101	11	0/1	001	0	1	0	0/1	CH3:011 CH4:100 CH5:101
	TGIV5 (input capture/compare match)	Arbitrary	Arbitrary	0001_1110	11	0/1	001	0	1	0	0/1	CH6:110 CH7:111
	TGIW5 (input capture/compare match)	Arbitrary	Arbitrary	0001_1111	11	0/1	001	0	1	0	0/1	CH8:000 CH9:001 CH10:010
MTU3 ch6	TGIA6 (input capture/compare match)	Arbitrary	Arbitrary	0010_0000	11	0/1	001	0	1	0	0/1	CH11:011 CH12:100 CH13:101
	TGIB6 (input capture/compare match)	Arbitrary	Arbitrary	0010_0001	11	0/1	001	0	1	0	0/1	CH14:110 CH15:111
	TGIC6 (input capture/compare match)	Arbitrary	Arbitrary	0010_0010	11	0/1	001	0	1	0	0/1	
	TGID6 (input capture/compare match)	Arbitrary	Arbitrary	0010_0011	11	0/1	001	0	1	0	0/1	
MTU3 ch7	TGIA7 (input capture/compare match)	Arbitrary	Arbitrary	0010_0100	11	0/1	001	0	1	0	0/1	
	TGIB7 (input capture/compare match)	Arbitrary	Arbitrary	0010_0101	11	0/1	001	0	1	0	0/1	
	TGIC7 (input capture/compare match)	Arbitrary	Arbitrary	0010_0110	11	0/1	001	0	1	0	0/1	
	TGID7 (input capture/compare match)	Arbitrary	Arbitrary	0010_0111	11	0/1	001	0	1	0	0/1	
	TCIV7 (input capture/compare match)	Arbitrary	Arbitrary	0010_1000	11	0/1	001	0	1	0	0/1	
MTU3 ch8	TGIA8 (input capture/compare match)	Arbitrary	Arbitrary	0010_1001	11	0/1	001	0	1	0	0/1	
	TGIB8 (input capture/compare match)	Arbitrary	Arbitrary	0010_1010	11	0/1	001	0	1	0	0/1	
	TGIC8 (input capture/compare match)	Arbitrary	Arbitrary	0010_1011	11	0/1	001	0	1	0	0/1	
	TGID8 (input capture/compare match)	Arbitrary	Arbitrary	0010_1100	11	0/1	001	0	1	0	0/1	

Table 14.3 On-Chip Module Requests (3/5)

DMA Transfer

Request Source	DMA Transfer Request Signal	Transfer Source	Transfer Destination	DMARSn/nS		CHCFG_n/nS*1						
				MID [7:0]	RID [1:0]	TM	AM [2:0]	LVL	HIEN	LOEN	REQD	SEL[2:0]
SSIF ch0	INT_ssif_dma_rx_0 (receive data full)	SSIF RDR_0	Arbitrary	10010101	10	0	010	0	1	0	0	CH0:000 CH1:001
	INT_ssif_dma_tx_0 (transmit data empty)	Arbitrary	SSIF TDR_0	10010101	01	0	010	0	1	0	1	CH2:010 CH3:011
SSIF ch1	NT_ssif_dma_rx_1 (receive data full)	SSIF RDR_1	Arbitrary	10010110	10	0	010	0	1	0	0	CH4:100 CH5:101
	INT_ssif_dma_tx_1 (transmit data empty)	Arbitrary	SSIF TDR_1	10010110	01	0	010	0	1	0	1	CH6:110 CH7:111
SSIF ch2	INT_ssif_dma_rt_2 (receive data full)	SSIF RDR_2	Arbitrary	10010111	11	0	010	0	1	0	0	CH8:000 CH9:001
	INT_ssif_dma_tx_2 (transmit data empty)	Arbitrary	SSIF TDR_2	10010111	11	0	010	0	1	0	1	CH10:010 CH11:011
SSIF ch3	INT_ssif_dma_rx_3 (receive data full)	SSIF RDR_3	Arbitrary	10011000	10	0	010	0	1	0	0	CH12:100 CH13:101
	INT_ssif_dma_tx_3 (transmit data empty)	Arbitrary	SSIF TDR_3	10011000	01	0	010	0	1	0	1	CH14:110 CH15:111
I2C ch0	INTRIIC_RI0 (receive data full)	RIIC0DRR	Arbitrary	10011010	10	0	010	0	1	0	0	
	INTRIIC_TI0 (transmit data empty)	Arbitrary	RIIC0DRT	10011010	01	0	010	0	1	0	1	
I2C ch1	INTRIIC_RI1 (receive data full)	RIIC1DRR	Arbitrary	10011011	10	0	010	0	1	0	0	
	INTRIIC_TI1 (transmit data empty)	Arbitrary	RIIC1DRT	10011011	01	0	010	0	1	0	1	
I2C ch2	INTRIIC_RI2 (receive data full)	RIIC2DRR	Arbitrary	10011100	10	0	010	0	1	0	0	
	INTRIIC_TI2 (transmit data empty)	Arbitrary	RIIC2DRT	10011100	01	0	010	0	1	0	1	
I2C ch3	INTRIIC_RI3 (receive data full)	RIIC3DRR	Arbitrary	10011101	10	0	010	0	1	0	0	
	INTRIIC_TI3 (transmit data empty)	Arbitrary	RIIC3DRT	10011101	01	0	010	0	1	0	1	
SCIF ch0	RX10 (receive FIFO data full)	FRDR0	Arbitrary	10011110	10	0	100	1	1	0	0	
	TX10 (transmit FIFO data empty)	Arbitrary	FTDR0	10011110	01	0	100	1	1	0	1	
SCIF ch1	RX11 (receive FIFO data full)	FRDR1	Arbitrary	10011111	10	0	100	1	1	0	0	
	TX11 (transmit FIFO data empty)	Arbitrary	FTDR1	10011111	01	0	100	1	1	0	1	
SCIF ch2	RX12 (receive FIFO data full)	FRDR2	Arbitrary	10100000	10	0	100	1	1	0	0	
	TX12 (transmit FIFO data empty)	Arbitrary	FTDR2	10100000	01	0	100	1	1	0	1	
SCIF ch3	RX13 (receive FIFO data full)	FRDR3	Arbitrary	10100001	10	0	100	1	1	0	0	
	TX13 (transmit FIFO data empty)	Arbitrary	FTDR3	10100001	01	0	100	1	1	0	1	

Table 14.3 On-Chip Module Requests (4/5)

Request Source	DMA Transfer Request Signal	Transfer Source	Transfer Destination	DMARSn/nS		CHCFG_n/nS*1						
				MID [7:0]	RID [1:0]	TM	AM [2:0]	LVL	HIEN	LOEN	REQD	SEL[2:0]
SCIF ch4	RX14 (receive FIFO data full)	FRDR4	Arbitrary	10100010	10	0	100	1	1	0	0	CH0:000 CH1:001
	TX14 (transmit FIFO data empty)	Arbitrary	FTDR4	10100010	01	0	100	1	1	0	1	CH2:010 CH3:011 CH4:100
SClg ch0	RX10 (receive FIFO data full)	RDR0	Arbitrary	10100011	10	0	010	1	1	0	0	CH5:101 CH6:110
	TX10 (transmit FIFO data empty)	Arbitrary	TDR0	10100011	01	0	010	1	1	0	1	CH7:111 CH8:000 CH9:001
SClg ch1	RX11 (receive FIFO data full)	RDR1	Arbitrary	10100100	10	0	010	1	1	0	0	CH10:010 CH11:011
	TX11 (transmit FIFO data empty)	Arbitrary	TDR1	10100100	01	0	010	1	1	0	1	CH12:100 CH13:101 CH14:110 CH15:111
RSPI ch0	SPRI0 (receive buffer full)	SPDR0	Arbitrary	10100101	10	0	010	1	1	0	0	
	SPTI0 (transmit buffer empty)	Arbitrary	SPDR0	10100101	01	0	010	1	1	0	1	
RSPI ch1	SPRI1 (receive buffer full)	SPDR1	Arbitrary	10100110	10	0	010	1	1	0	0	
	SPTI1 (transmit buffer empty)	Arbitrary	SPDR1	10100110	01	0	010	1	1	0	1	
RSPI ch2	SPRI2 (receive buffer full)	SPDR2	Arbitrary	10100111	10	0	010	1	1	0	0	
	SPTI2 (transmit buffer empty)	Arbitrary	SPDR2	10100111	01	0	010	1	1	0	1	
TSIP	WRRDY1	Arbitrary	TSIP_REG	10101000	11	0	001	0	1	0	0/1	
	WRRDY0	Arbitrary	TSIP_REG	10101001	11	0	001	0	1	0	0/1	
	WRRDY4	Arbitrary	TSIP_REG	10101010	11	0	001	0	1	0	0/1	
	RDRDY1	TSIP_REG	Arbitrary	10101011	11	0	001	0	1	0	0/1	
	RDRDY0	TSIP_REG	Arbitrary	10101100	11	0	001	0	1	0	0/1	
	IRDRDY	TSIP_REG	Arbitrary	10101101	11	0	001	0	1	0	0/1	
	IWRRDY	Arbitrary	TSIP_REG	10101110	11	0	001	0	1	0	0/1	

Table 14.3 On-Chip Module Requests (5/5)

DMA Transfer

Request Source	DMA Transfer Request Signal	Transfer Source	Transfer Destination	DMARSn/nS		CHCFG_n/nS ^{*1}						
				MID [7:0]	RID [1:0]	TM	AM [2:0]	LVL	HIEN	LOEN	REQD	SEL[2:0]
CANFD	RXF_DMA0	RSCFD0CF DRFDF0_0	Arbitrary	10101111	11	0	001	0	1	0	0/1	CH0:000 CH1:001
	RXF_DMA1	RSCFD0CF DRFDF0_1	Arbitrary	10110000	11	0	001	0	1	0	0/1	CH2:010 CH3:011
	RXF_DMA2	RSCFD0CF DRFDF0_2	Arbitrary	10110001	11	0	001	0	1	0	0/1	CH4:100 CH5:101
	RXF_DMA3	RSCFD0CF DRFDF0_3	Arbitrary	10110010	11	0	001	0	1	0	0/1	CH6:110 CH7:111
	RXF_DMA4	RSCFD0CF DRFDF0_4	Arbitrary	10110011	11	0	001	0	1	0	0/1	CH8:000 CH9:001
	RXF_DMA5	RSCFD0CF DRFDF0_5	Arbitrary	10110100	11	0	001	0	1	0	0/1	CH10:010 CH11:011
	RXF_DMA6	RSCFD0CF DRFDF0_6	Arbitrary	10110101	11	0	001	0	1	0	0/1	CH12:100 CH13:101
	RXF_DMA7	RSCFD0CF DRFDF0_7	Arbitrary	10110110	11	0	001	0	1	0	0/1	CH14:110 CH15:111
	COM_DMA0 (transceiver FIFO receive mode only)	RSCFD0CF DRFDF0_0	Arbitrary	10110111	11	0	001	0	1	0	0/1	
	COM_DMA1 (transceiver FIFO Receive mode only)	RSCFD0CF DRFDF0_1	Arbitrary	10111000	11	0	001	0	1	0	0/1	

Note 1. CHCFG_n/nS setting value

- TM 0: Single transfer
 1: Block transfer
- AM 001: ACK level output
 010: ACK bus cycle output
 100: No ACK
- LVL 0: REQ edge detection
 1: REQ level detection
- REQD 0: ACK output at read
 1: ACK output at write

Note 2. Only in products with a Trusted Secure IP

14.6 DMA Mode

14.6.1 Mode Setting

The DMS field of the CHCFG_n/nS register can be used to toggle between register mode and link mode.

Table 14.4 DMA Mode Setting

DMS (CHCFG_n/nS)	Mode	Description
0	Register mode	A DMA transfer is executed using the values set in the Next Register Set.
1	Link mode	A DMA transfer is executed using the descriptor set in the Current register. The DMAC repeatedly loads the descriptor and executes the DMA transfer unless otherwise set by the descriptor or stopped by the control register.

14.6.2 Register Mode

In register mode, a DMA transfer is executed using the values set in the internal registers.

Two sets of the source address, destination address, and transfer byte count (Next0 Register Set and Next1 Register Set) can be set. It is possible to select the Next register set to be used for the DMA transfer, as well as to execute two Next register sets continuously for the DMA transfer.

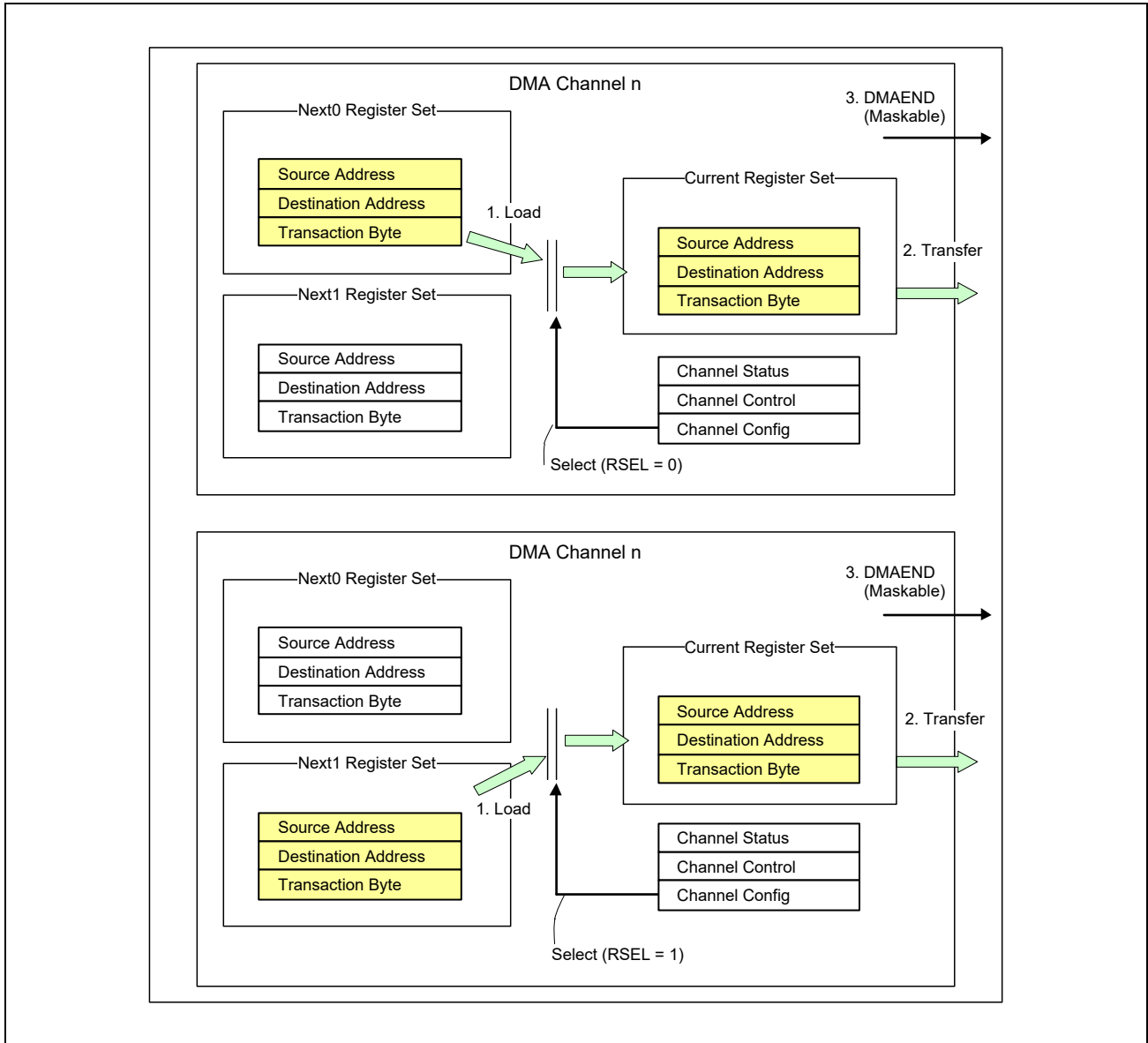

Figure 14.2 Outline of Normal Register Mode

The above figure shows how the transfer is executed when the Next0 Register Set is used (upper part of the figure) and when the Next1 Register Set is used (lower part of the figure).

(1) Operation Flow

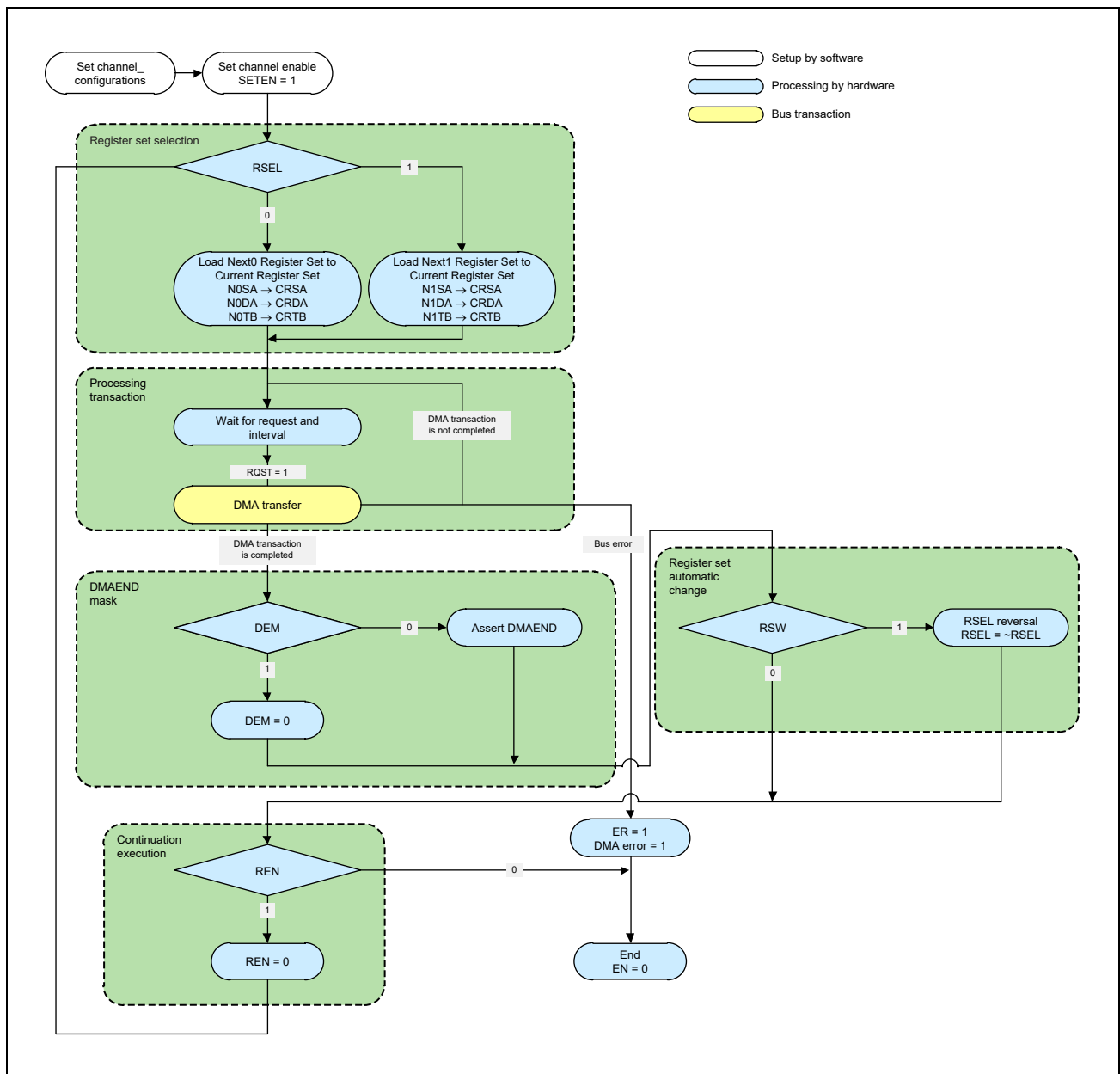

Figure 14.3 Register Mode Flow

<Explanation of the register mode flow>

1. Channel setting (set channel configuration)

The Next0 or Next1 register set (destination address, source address, and total transfer byte count) is set.

In the Channel register set, the DMA register set (REQ, DMAACK, transfer size, etc.) is set. (See **Section 14.7, DMA Transfer.**)

2. Register set selection (register set selection)

When 1 is set in EN, the values set in the Next register set selected by RSEL are loaded to the Current register set.

3. DMA transaction (processing transaction)

A DMA transfer is executed according to the set values. For details of the transfer, see **Section 14.7, DMA Transfer**.

4. DMA transfer end interrupt mask (DMAINT mask)

The DMA transfer end interrupt is masked according to the value set in the DEM bit of CHCFG_n/nS. When 1 is set in DEM, the DMA transfer end interrupt is not output. Also, immediately after that, DEM is automatically cleared to 0.

5. Automatic register set change (register set automatic change)

Whether to use the other Next register set is determined by the value set in the RSW bit of CHCFG_n/nS.

6. Continuation of execution (continuation execution)

Whether to continue the execution of the DMA transfer is determined by the value set in the REN bit of CHCFG_n/nS. When 1 is set in REN, the execution of the DMA transfer is continued. Also, immediately after that, REN is automatically cleared to 0.

(2) Register Setting

(a) Register mode setting

Select the register set to be executed.

Table 14.5 Register Mode Setting

DMS (CHCFG_n/nS)	RSEL (CHCFG_n/nS)	Description
0	0	Executes the Next0 Register Set.
	1	Executes the Next1 Register Set.

(b) DMA transfer end interrupt mask setting

The DMA transfer end interrupt can be masked individually for each register set.

Table 14.6 DMAINT Mask Setting

DEM (CHCFG_n/nS)	Operation
0	When the DMA transaction is completed, a DMA transfer end interrupt is issued.
1	Even when the DMA transaction is completed, a DMA transfer end interrupt is not issued. After the DMA transaction is completed, DEM is cleared to 0 by hardware.

(c) Automatic register set execution setting

After DMA transfers, the DMA transaction of the selected register set is automatically executed.

Table 14.7 Automatic Register Set Execution Setting

REN (CHCFG_n/nS)	Operation	Remark
0	When the DMA transaction of the register set selected by RSEL is completed, the EN bit is cleared and the DMA operation ends.	Set this value to execute a DMA transaction once.
1	When a DMA transaction is completed, the DMAC continues to execute a DMA transfer by using the data set in the selected register set. When continuous transfers are successful, REN is cleared to 0.	Set this value to continuously execute DMA transfers by using the data set in separate register sets.

(d) Automatic register set change setting

When 1 is set in REN, the DMAC can automatically change to the register set to be executed next, after a DMA transaction is completed.

Table 14.8 Automatic Register Set Change Setting

RSW (CHCFG_n/nS)	Operation	Remark
0	If 1 is set in REN when a DMA transaction is completed, the register set is not changed.	Set this value to use only one register set.
1	If 1 is set in REN when a DMA transaction is completed, the value of RSEL is automatically inverted and the other register set is selected.	Set this value to change the register set.

(3) Setting Examples**(a) When only the Next0 register set is used**

Table 14.9 Register Mode Setting Example 1

DMS (CHCFG_n/nS)	RSEL (CHCFG_n/nS)	DEM (CHCFG_n/nS)	RSW (CHCFG_n/nS)	REN (CHCFG_n/nS)
0 (Register mode)	0 (Next0)	0 (not masked)	0 (not switched)	0 (not continuously executed)

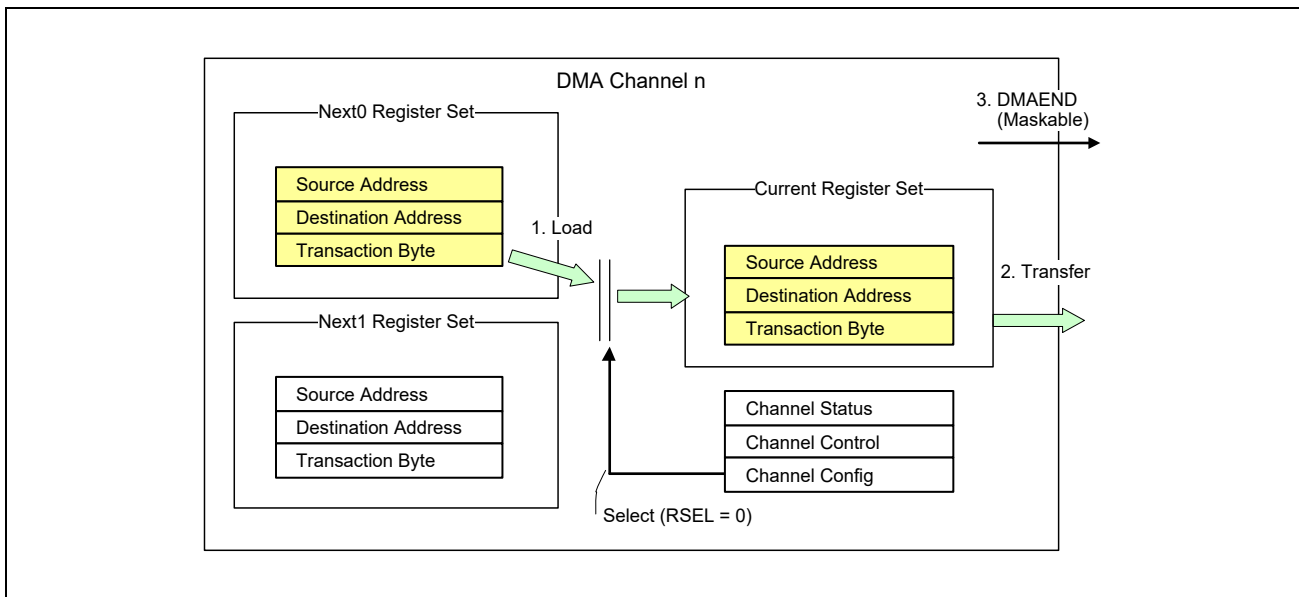

Figure 14.4 Register Mode Setting Example 1

- 1 is set in EN (SETEN = 1), and the Next0 register set is loaded to the Current register set.
- A DMA transaction is executed according to the values set in the Current register set and Channel register set.
- Because 0 is set in DEM, the DMA transfer end interrupt is issued after the DMA transaction is completed.
- Because 0 is set in REN, EN is cleared to 0 and the DMA transaction ends.

(b) When two register sets are used continuously

Table 14.10 Automatic Register Set Execution Setting

DMS (CHCFG_n/nS)	RSEL (CHCFG_n/nS)	DEM (CHCFG_n/nS)	RSW (CHCFG_n/nS)	REN (CHCFG_n/nS)
0 (Register mode)	0 (Next0)	1 (masked)	1 (switched)	1 (continuously executed)

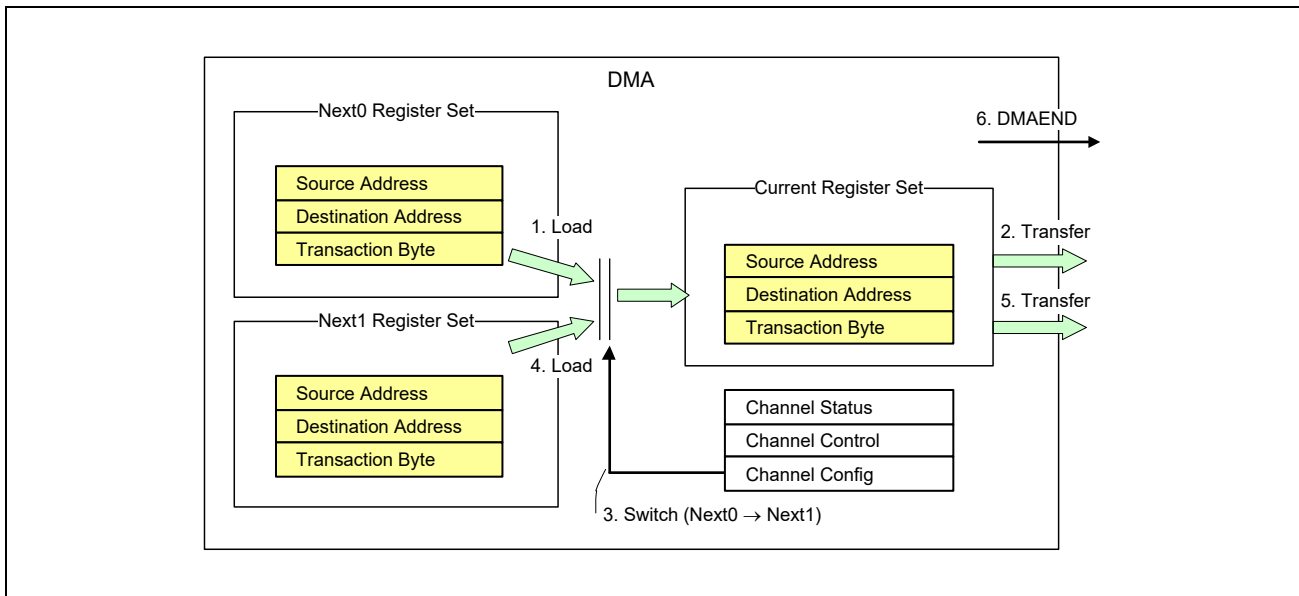

Figure 14.5 Register Mode Setting Example 2

1. 1 is set in EN (SETEN = 1), and the Next0 register set is loaded to the Current register set.
2. A DMA transaction is executed according to the values set in the Current register set and Channel register set.
3. Because 1 is set in DEM, DMA transfer end interrupt is not output after the DMA transaction is completed. Also, DEM is automatically cleared to 0.
4. Because 1 is set in REN, the execution is continued. Also, REN is automatically cleared to 0.
5. Because 1 is set in RSW, the register set to be executed next is switched (RSEL = 0 → 1).
6. The Next1 register set is loaded to the Current register set.
7. A DMA transaction is executed according to the values set in the Current register set and Channel register set.
8. Because 0 is set in DEM, the DMA transfer end interrupt is issued after the DMA transaction is completed.
9. Because 0 is set in REN, EN is cleared to 0 and the DMA transaction ends.

14.6.3 Link Mode

In link mode, a descriptor stored in external memory is loaded as set values and a DMA transaction is executed using the loaded values. The DMAC contains a Next Link address and a Current Link address for each channel, and these addresses are used to set the descriptor address to be executed next and to indicate the descriptor address of the currently executed DMA transaction, respectively.

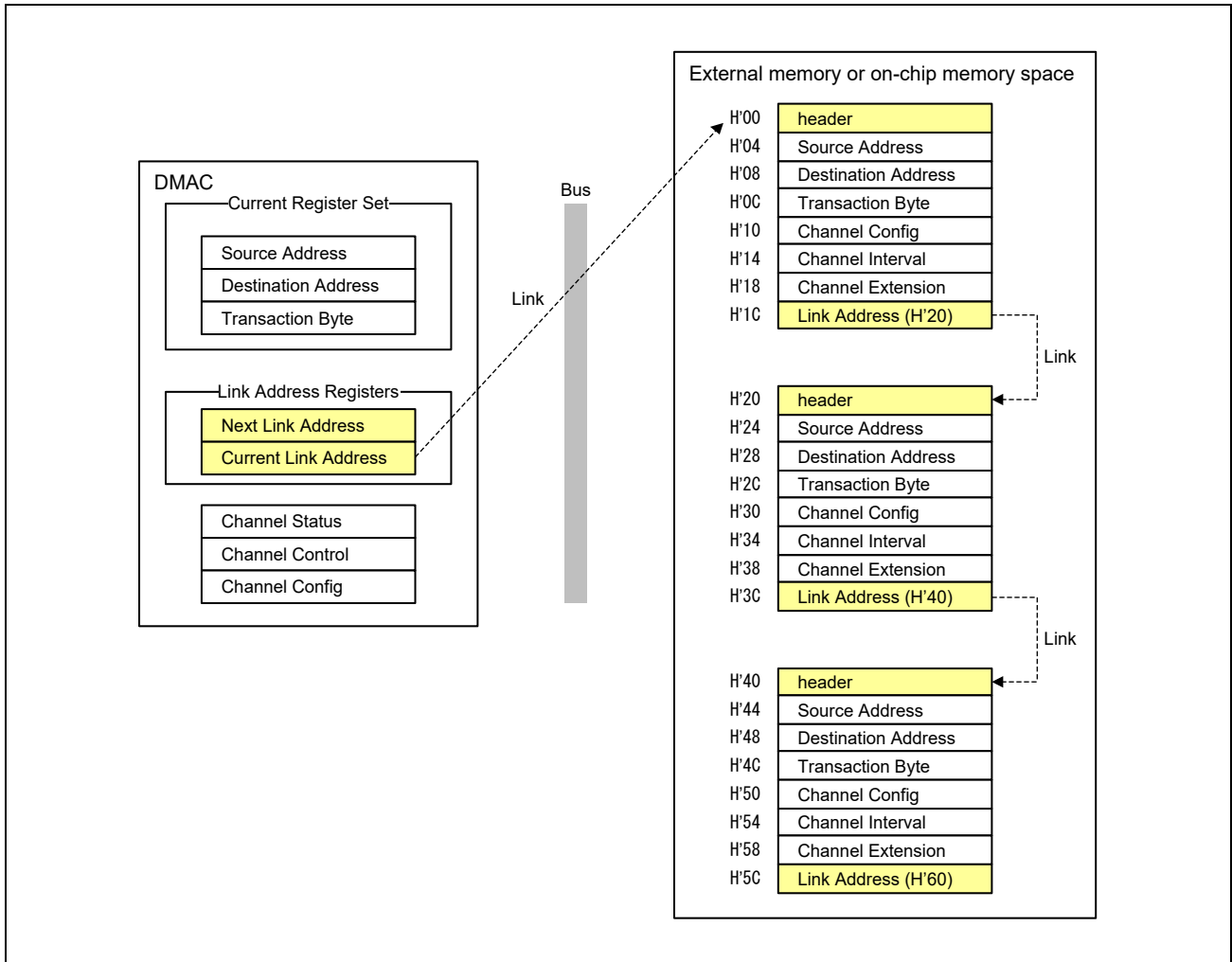

Figure 14.6 Link Mode Outline

(1) Operation Flow

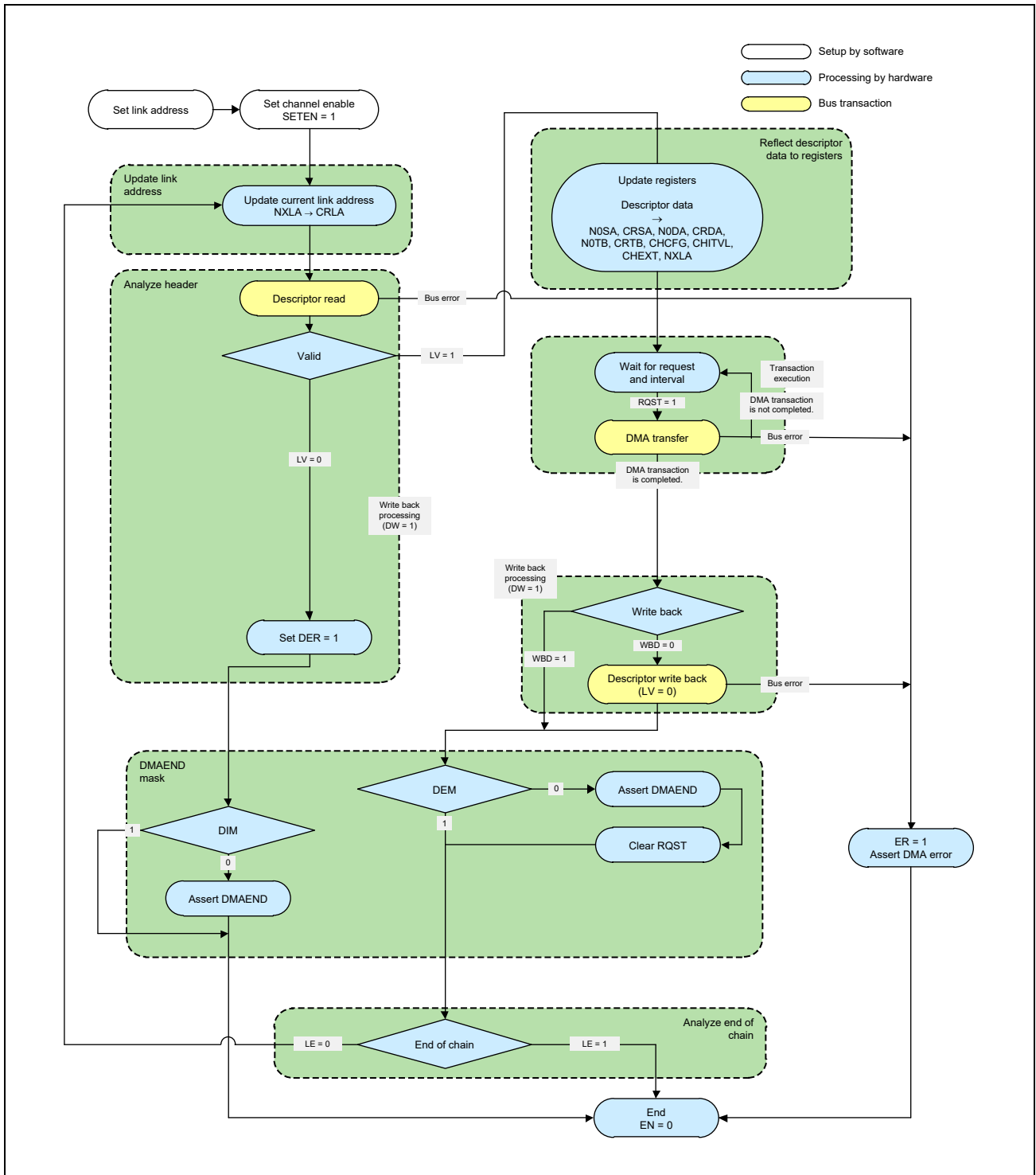

Figure 14.7 Link Mode Flow

<Explanation of the link mode flow>

1. Channel setting

The start address of the link destination is set in NXLA_n/nS.

2. Link address update

When 1 is set in EN (1 is set in SETEN), the Link address set in NXLA_n/nS is loaded to CRLA_n/nS.

3. Descriptor load and header analysis

The DMAC begins to load the descriptor and then analyzes the content of the header. When LV is 0, the DMAC discards the loaded descriptor and sets 1 in DER to end the operation (EN = 0). In this case, if 0 is set in DIM of the header, DMAEND is issued.

4. Descriptor setting

The loaded descriptor is set in the Current register set and Channel register set. Also, the next link address is set in NXLA_n/nS.

5. DMA transaction

A DMA transaction is executed according to the set values.

6. Header writeback

When 0 is set in WBD of the header, the DMAC writes back the header with 0 set in its LV bit.

7. DMAINT mask

When 0 is set in the DEM bit of CHCFG_n/nS, the DMA transfer end interrupt is issued.

8. Link end analysis

When 1 is set in LE of the header, the operation is ended by clearing EN to 0, after transfer using the settings of the descriptor is completed. If the setting of LE is 0, the Current registers are then updated and loading of the next descriptor begins. The TEND signal is issued after the transfer of each descriptor.

(2) Register Setting

(a) Link mode setting

To use the link mode, set 1 in the DMS bit of the CHCFG_n/nS register.

Table 14.11 Link Mode Setting

DMS (CHCFG_n/nS)	Description
1	Operates in link mode. This bit cannot be changed using a descriptor.

(b) Link address setting

There are two registers that indicate a link address:

Next Link address register and Current Link address register.

To start the link mode, set a link address in the Next Link address register.

The Next Link address indicates the next link address after a descriptor is loaded. The Current Link address indicates the currently executed link address.

Table 14.12 Link Address Register Set

Register	Description
Next Link Address Register (NXLA_n/nS)	Sets and indicates the next link address. Before starting the link mode, set a link address in this register.
Current Link Address Register (CRLA_n/nS)	Indicates the currently executed link address. This register is read-only.

CAUTION

In link mode, the settings can be changed by reading a descriptor. It is not possible, however, to synchronize the change of the settings with a peripheral module request or external request. Therefore, when using a peripheral module request or external request, set AM, LVL, HIEN, LOEN, and SEL of the CHCFG_n/nS register before setting Enable and do not change any of these bits in the descriptor.

(3) Descriptor Setting

In a link address, prepare a descriptor with data arranged in the order shown below.

The DMAC reads the descriptor in burst mode.

(a) Descriptor data arrangement

Table 14.13 Descriptor Data Arrangement

Address	Data	Remarks
Link address + H'00	header	
Link address + H'04	Source Address	
Link address + H'08	Destination Address	
Link address + H'0C	Transaction Byte	
Link address + H'10	Config	The register mode cannot be set.
Link address + H'14	Interval	
Link address + H'18	Extension	
Link address + H'1C	Next Link Address	

Note: As a link address, set an address aligned along the 32-bit boundary.

(b) header

The header indicates the status of the descriptor, as shown below.

The DMAC reads this area when a DMA transfer is started in link mode. Also, after a DMA transaction is completed, the DMAC writes back the transfer status to the area.

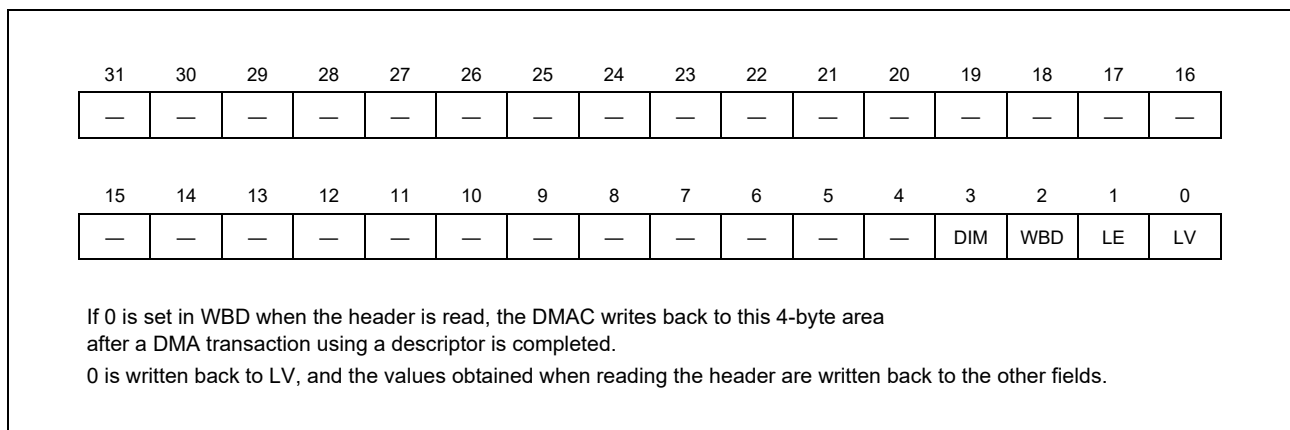

Figure 14.8 Header Area

Table 14.14 Header Area

Bit Position	Bit Name	Meaning
31 to 4	—	—
3	DIM	Descriptor Interrupt Mask Sets whether to mask the DMA transfer end interrupt if 0 is set in LV when the header is loaded. 0: Issues a DMA transfer end interrupt. 1: Does not issue a DMA transfer end interrupt.
2	WBD	Write Back Disable Sets whether to mask LV bit writeback. When 1 is set in this bit, the DMAC does not perform writeback. 0: Writes the LV bit back to 0. 1: Does not write back the LV bit.
1	LE	Link End Indicates whether the link ends with the DMA transaction of this descriptor. Set 1 in this bit to indicate the end of the link. 0: The link continues. 1: The link ends.
0	LV	Link Valid Indicates whether this descriptor is valid. If 0 is set in WBD, the DMAC writes 0 in this bit after the DMA transaction written in the descriptor is executed. When setting the header, set 1 in this bit. 0: Descriptor invalid 1: Descriptor valid

(c) Descriptor data other than the header

The data items of the descriptor other than the header are the same as defined in the internal register specifications (note that the DMS bit of the CHCFG_n/nS register cannot be changed using the descriptor). For information about the internal register specifications, see **Section 14.4, Register Descriptions**.

For descriptor setting examples, see **Section 14.8, DMA Setting Examples**.

(d) CACHE settings for descriptor access

The CACHE settings for descriptor access can be set in LWCA and LDCA of the DMA control register (DCTRL_0_7/0_7S, DCTRL_8_15/8_15S). Make these settings as appropriate for the access destination in which the descriptor is prepared.

(e) Descriptor area and DMA transfer area

The following figure outlines the descriptor area and DMA transfer area that are accessed by the DMAC.

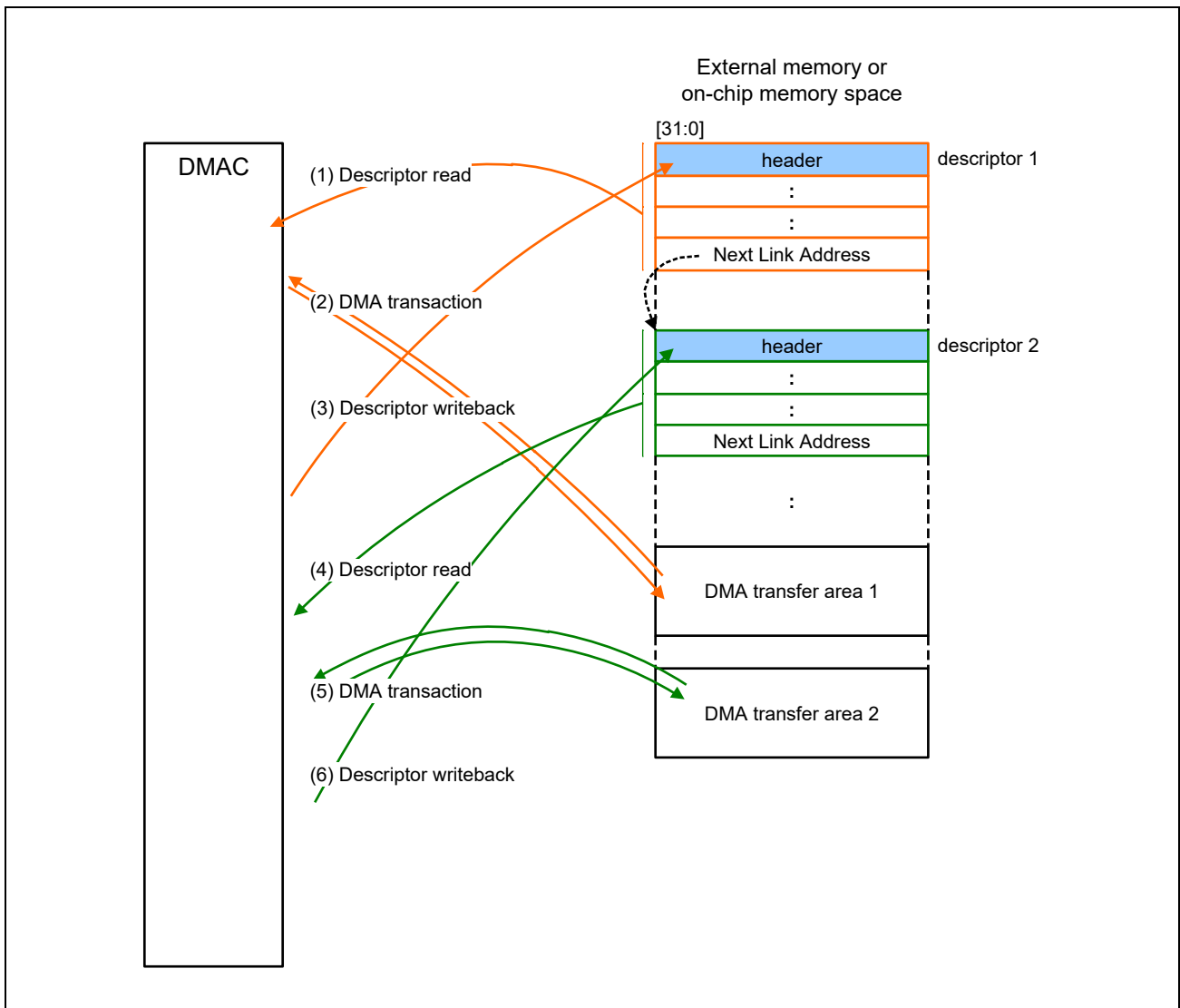

Figure 14.9 Outline of the Descriptor Area and DMA Transfer Area

1. Descriptor read

The values set in the internal Next Link Address register are loaded to the Current Link Address register, and a descriptor is read from the external memory space (descriptor1) pointed to by the Current Link Address register.

2. DMA transfer

When 1 is set in the LV bit of the header in the descriptor, a DMA transfer is executed according to the descriptor data.

3. Descriptor writeback

When 0 is set in the WBD bit of the header after the DMA transfer of the set number of bytes is completed, the DMAC writes back data in word size to the header of descriptor1, with 0 set in LV and the other bits containing the values read in <1>.

4. Descriptor read

When 0 is set in the LE bit of the header in the last read descriptor (<1>), the next descriptor is read from the address (descriptor2) indicated by Next Link Address in the descriptor.

5. DMA transfer

When 1 is set in the LV bit of the header in the descriptor, a DMA transfer is executed according to the descriptor data.

6. Descriptor writeback

When 0 is set in the WBD bit of the header after the DMA transfer of the set number of bytes is completed, the DMAC writes back data in word size to the header of descriptor2, with 0 set in LV and the other bits containing the values read in <4>.

4 through 6 are repeated.

When the header contains 1 in LE and 0 in WBD, the DMAC executes a DMA transfer using the settings of that descriptor, writes back data with 0 set in the LV bit of the header and ends the operation.

When the header contains 1 in both LE and WBD, the DMAC executes a DMA transfer using the settings of that descriptor and ends the operation (without writing back).

When the header contains 0 in LV, the DMAC ends the operation (without executing a DMA transfer).

(4) Descriptor Configuration Examples

In link mode, a descriptor can be configured as shown below.

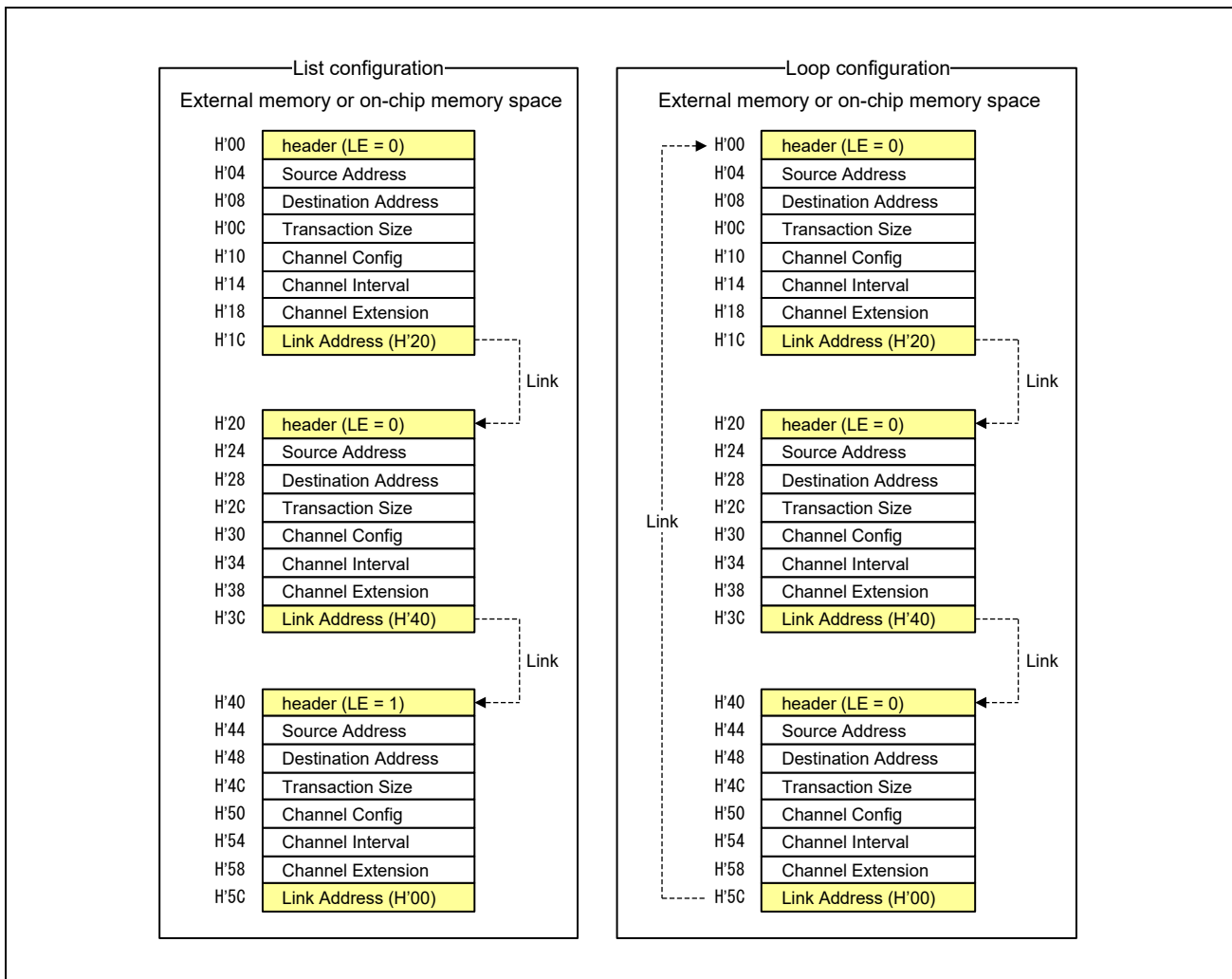

Figure 14.10 Descriptor Configuration Examples

- List configuration

The link is ended by setting 1 in the LE bit of the header in the last descriptor.

- Loop configuration

A descriptor can be created with a loop configuration, by setting the address of the top descriptor in the link address of the last descriptor. To end the loop, change the value of the LE bit of the header to 1 before the DMAC reads the descriptor, or follow the transfer suspension procedure.

14.7 DMA Transfer

The basic operation of DMA transfer is described here.

14.7.1 Transfer Mode

Two transfer modes are supported: single transfer mode and block transfer mode.

To select a transfer mode, set the TM bit of CHCFG_n/nS for each channel.

Table 14.15 Basic Transfer Setting

Transfer Mode	TM (CHCFG_n/nS)	Function
Single transfer	0	A single DMA transfer is executed in response to a DMAREQ.
Block transfer	1	In response to a DMAREQ, the DMAC continues to execute the transfer until the DMA transaction is completed.

(1) Single Transfer Mode

When a DMA transfer request is received, a DMA transfer is executed once in the direction indicated by REQD (source or destination). A DMA transfer is executed once each time a transfer request is received, and this operation continues until the number of bytes loaded to CRTB_n/nS is reached (arbitration between channels is accomplished for each DMA transfer).

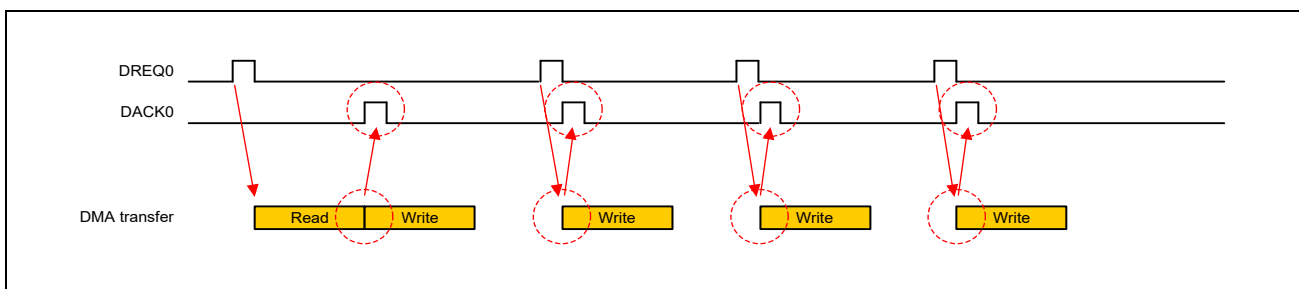

Figure 14.11 Single Transfer Mode (REQD = 1, SDS > DDS)

(2) Block Transfer Mode

Once a DMA transfer request is received, the DMAC continues to execute the transfer until data equivalent to the number of bytes loaded to the DMA transfer byte register (CRTB_n/nS register) is transferred (the DMA transaction is completed) (arbitration between channels is accomplished for each DMA transfer).

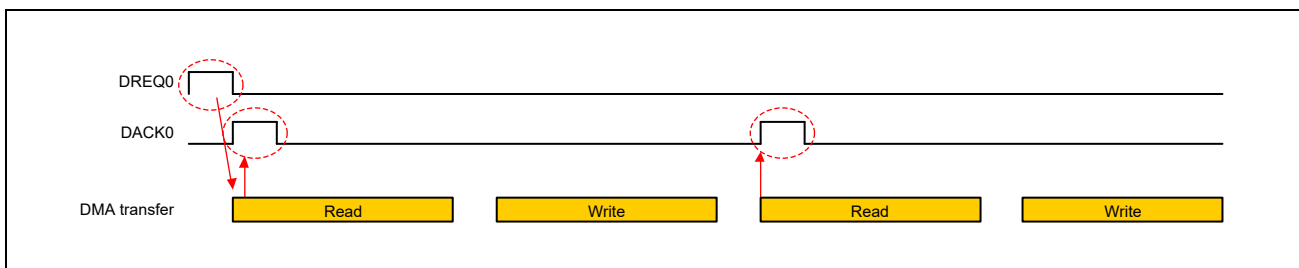

Figure 14.12 Block Transfer Mode (REQD = 0, SDS < DDS)

14.7.2 Priority Control for DMA Channels

Within channels 0 to 7 and 8 to 15, two priority control modes are supported: fixed priority mode and round robin mode. Only round robin mode is supported for priority control between the group of channels 0 to 7 and the group of channels 8 to 15. To select a priority control mode, use the PR bit of the DMA control register (DCTRL register). The fixed priority mode is selected when 0 is set in the PR bit, and the round robin mode is selected when 1 is set.

Read priority and write priority are controlled independently.

The DMAC issues transfer requests to different channels concurrently without waiting for the completion of any particular transfer and processes responses in the order it receives them. Therefore, the order in which the channels start transactions is not necessarily consistent with the order in which the transactions end.

Table 14.16 Priority Control Setting

Mode	PR (DCTRL)	Function	Purpose
Fixed priority	0	Requests are controlled based on the fixed order of priority for channels 0 to 7 and 8 to 15 (High: CH0 (CH8) > CH1 (CH9) > CH2 (CH10) > CH3 (CH11) > CH4 (CH12) > CH5 (CH13) > CH6 (CH14) > CH7 (CH15): Low).	Use this mode when the channels have a specific order of priority.
Round robin	1	Requests are controlled in a round robin fashion.	Use this mode to execute all requests evenly.

(1) Fixed Priority Mode

In fixed priority mode, the channels have a fixed order of priority in channels 0 to 7 and 8 to 15. Round robin mode is used to determine the priority between the group of channels 0 to 7 and the group of channels 8 to 15.

Immediately after a reset, the order of priority is as follows.

High CH0 > CH8 > CH1 > CH9 > CH2 > CH10 > CH3 > CH11 > CH4 > CH12 > CH5 > CH13 > CH6 > CH14 > CH7 > CH15 Low

If there is a transfer request from DMA channel 0 in this state, a transfer is executed on DMA channel 0. After the transfer is completed, the order of priority is as follows.

High CH8 > CH0 > CH9 > CH1 > CH10 > CH2 > CH11 > CH3 > CH12 > CH4 > CH13 > CH5 > CH14 > CH6 > CH15 > CH7 Low

If a DMA transfer request occurs on multiple channels simultaneously, the DMA transfer request of the channel having the smallest channel number is given priority. The following figure shows an example where a DMA transfer request occurs on a channel having a higher priority while a DMA transfer is being executed in fixed priority mode.

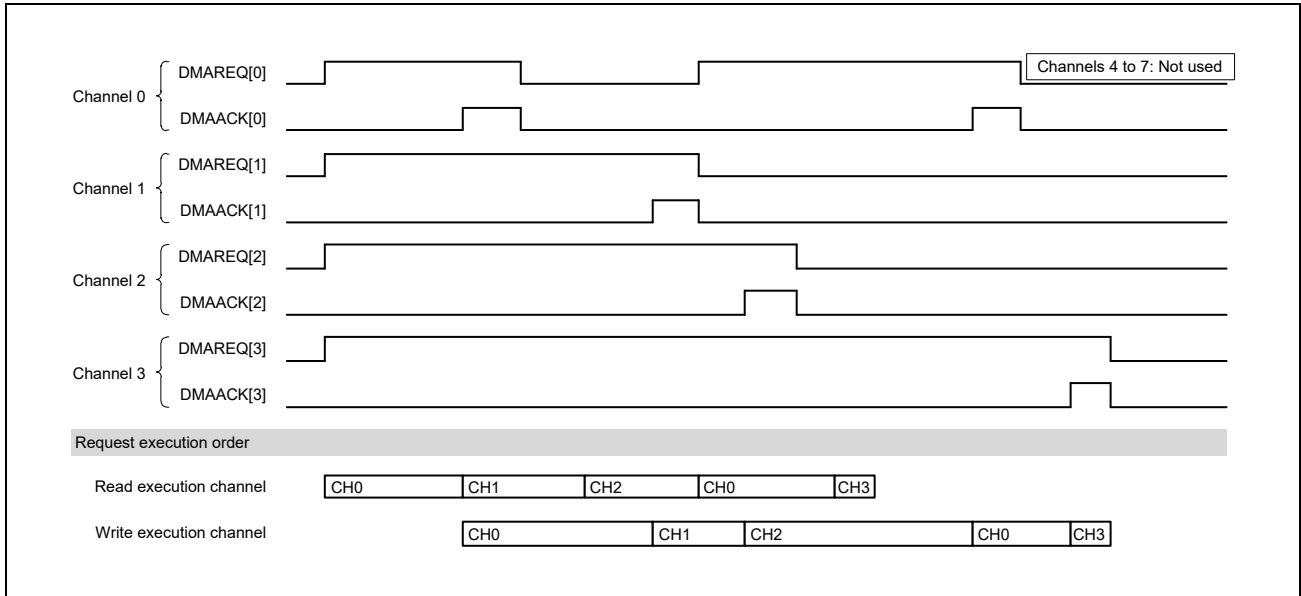

Figure 14.13 Fixed Priority Mode (Number of Channels = 4, REQD = 1)

(2) Round Robin Mode

In round robin mode, each time a transfer request is received from a channel in the group of channels 0 to 7 and the group of channels 8 to 15, the order of priority is changed in such a way that the channel that executed a transfer last has the lowest priority.

Round robin mode is used to determine the priority between the group of channels 0 to 7 and the group of channels 8 to 15.

Immediately after a reset, the order of priority is the same as that of the fixed priority mode, which is as follows.

High CH0 > CH8 > CH1 > CH9 > CH2 > CH10 > CH3 > CH11 > CH4 > CH12 > CH5 > CH13 > CH6 > CH14 > CH7 > CH15 Low

If a transfer request is received from DMA channel 2 in this state, a transfer is executed on DMA channel 2. After the transfer is completed, the order of priority is as follows.

High CH8 > CH3 > CH9 > CH4 > CH10 > CH5 > CH11 > CH6 > CH12 > CH7 > CH13 > CH0 > CH14 > CH1 > CH15 > CH2 Low

The following figure shows an example where DMA transfers are executed in round robin mode.

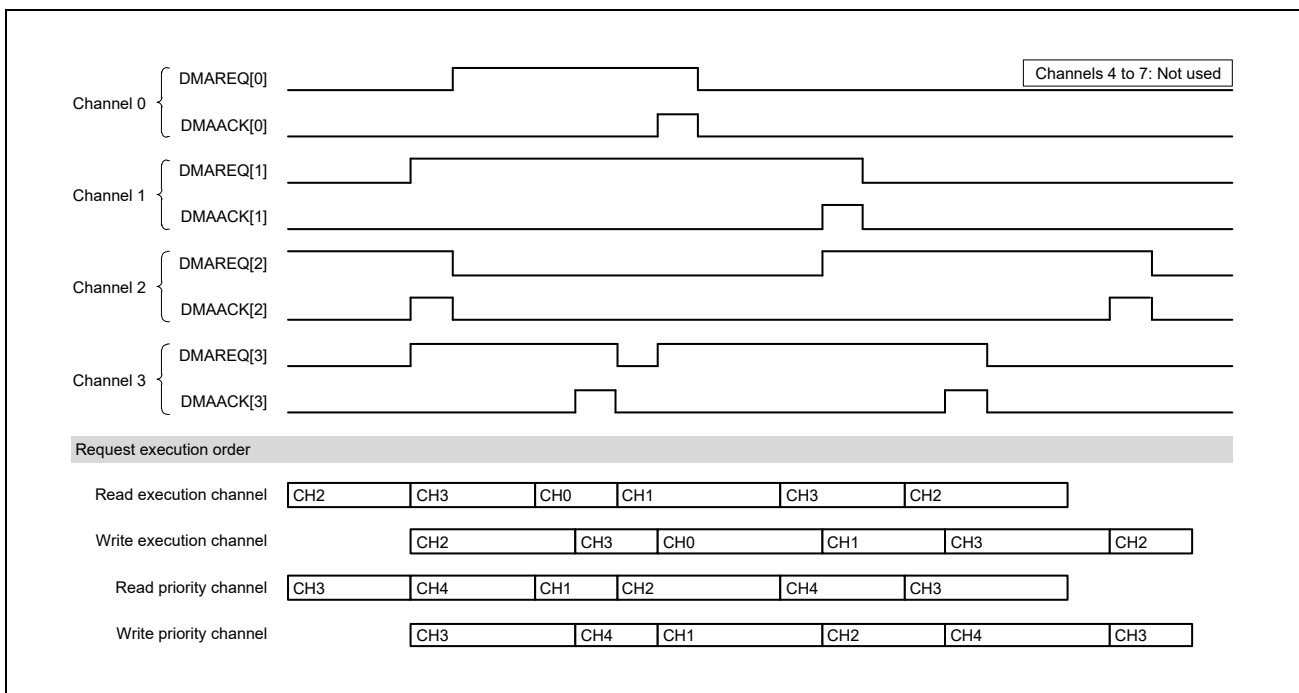

Figure 14.14 Round Robin Mode (Number of Channels = 4, REQD = 0)

The channel whose channel number is the number of the currently transferring channel + 1 gets to execute a DMA transfer next. If there is no transfer request from this channel, the channel whose channel number is the number of this channel + 1 gets to execute a DMA transfer.

14.7.3 DMA Transfer Request

Edge detection or level detection can be selected using the LVL bit of the CHCFG_n/nS register.

The HIEN and LOEN bits of the CHCFG_n/nS register are used to select either the rising edge or falling edge in the case of edge detection or either the high level or low level in the case of level detection.

When the transfer request is by an on-chip peripheral module, set the CHCFG_n/nS register according to **Table 14.3**.

(1) Edge Detection

Setting 0 in the LVL bit of the CHCFG_n/nS register enables edge detection.

(2) Level Detection

Setting 1 in the LVL bit of the CHCFG_n/nS register enables level detection.

14.7.4 DMA Transfer End Interrupt

The DMA transfer end interrupt is an interrupt request signal that indicates that a DMA transaction is completed. There is an independent DMA transfer end interrupt for each channel.

When the transfer of data equivalent to the total transfer byte count loaded to the CRTB (Current Transaction Byte) is completed, 1 is set in END of the CHSTAT_n/nS register. In this case, when 0 is set in DEM of the CHCFG_n/nS register, the DMA transfer end interrupt (DMAINTn_NS/S) is output (n = 0 to 15). (When writeback is performed in link mode, the signal is output after the writeback operation.)

When 0 is set in LV of the header in the read descriptor in link mode, 1 is set in DER of the CHSTAT_n/nS register. In this case, when 0 is set in DIM of the header, the DMA transfer end interrupt is output.

Table 14.17 Assertion Conditions of DMA Transfer End Interrupt

Source	Condition	DMA Transfer End Interrupt Mask Signal
DMA transaction end	When the transfer of data equivalent to the total transfer byte count loaded to the CRTB (Current Transaction Byte) is completed with an OKAY response (or after the writeback operation when writeback is performed in link mode)	DEM bit of the CHCFG_n/nS register
Descriptor invalid	When 0 is set in LV of the header in the read descriptor in link mode while 0 is set in DIM of the header	DIM bit of the header

14.7.5 DMA Error Interrupt

If an error response is received for a DMA transfer or descriptor access, the DMAC regards it as an error and stops the transfer. Upon receiving an error response, the EN bit of the CHSTAT_n/nS register of transferring channel n is cleared to 0 and 1 is set in the ER bit (n = 0 to 15). Also, the DMA error interrupt (DMAERR_NS/S) is output.

The DMA error interrupt cannot be masked.

Once an error occurs, the data of the whole transfer cannot be guaranteed. Be sure to start the transaction again from the beginning by following the procedure below.

1. Set 1 in the SWRST bit of the CHCTRL_n/nS register.
2. Set each register again.

14.7.6 Interval Count Function

The interval at which a DMA transfer is executed can be adjusted by setting the ITVL bit of the channel interval register (CHITVL_n/nS). This function is intended to prevent the DMA controller from occupying the bus all the time.

When a read or write operation is completed, a countdown starts from the value set in CHITVL_n/nS. The next internal request is not executed until the count value reaches 0.

The following figure shows an example of how this works.

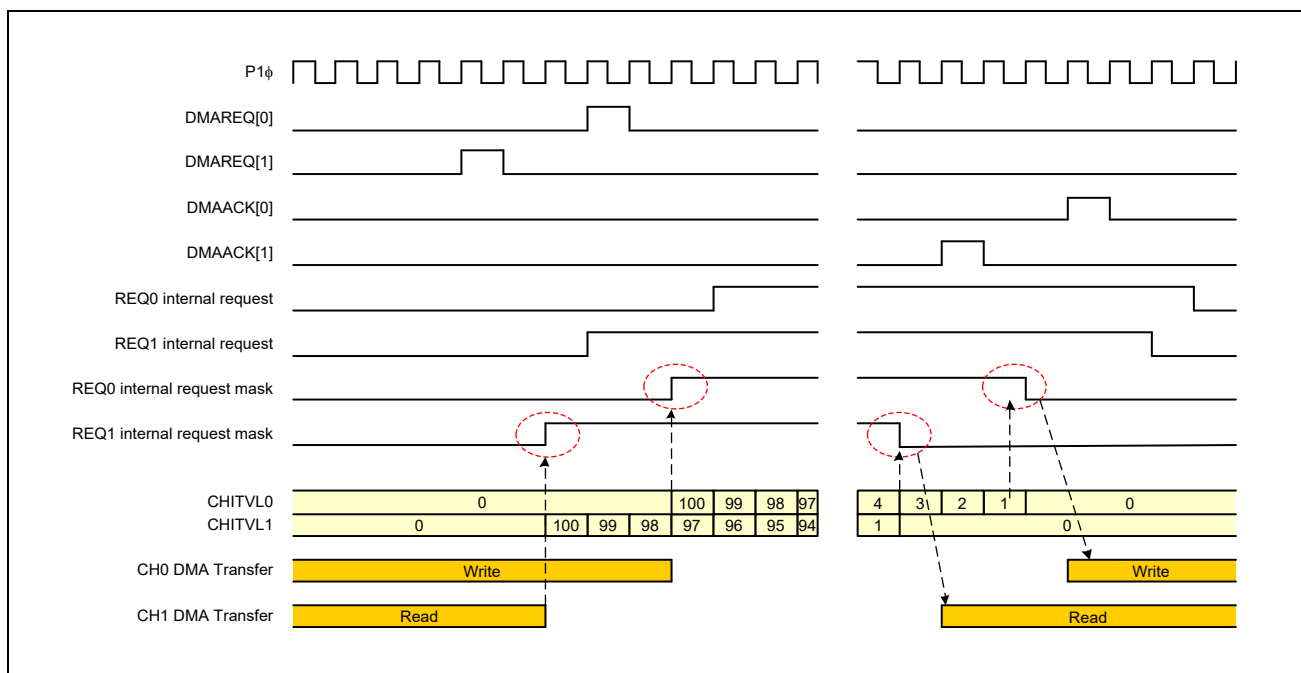

Figure 14.15 Interval Count

14.7.7 Difference in Operation Due to the Transfer Size

(1) When the Source Transfer Size Is Smaller

When the read of data equivalent to the destination data size is completed, the data is written to the destination.

The following figure shows a timing chart where the source transfer size is 8 bits and the destination transfer size is 32 bits (in the case of rising edge detection).

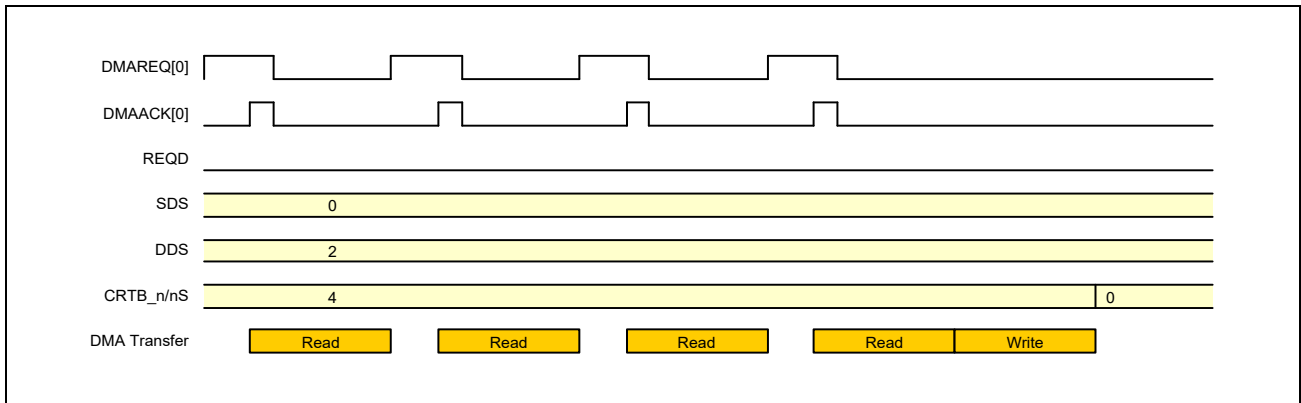

Figure 14.16 When the Source Transfer Size Is Smaller (LVL = 0, HIEN = 1, REQD = 0, SDS < DDS in CHCFG_n/nS)

(2) When the Destination Transfer Size Is Smaller

Since the source transfer size is larger, multiple destination writes occur after a single source read. The following figure shows a timing chart where the source transfer size is 64 bits and the destination transfer size is 16 bits (in the case of rising edge detection) (1 is set in REQD of the CHCFG_n/nS register).

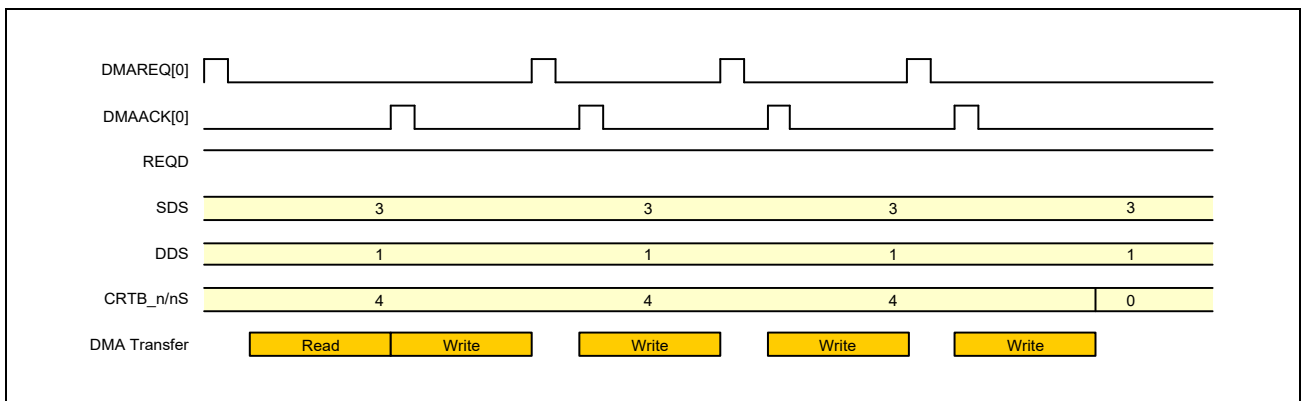

Figure 14.17 When the Destination Transfer Size Is Smaller (LVL = 0, HIEN = 1, REQD = 1, SDS > DDS in CHCFG_n/nS)

(3) When the Source Transfer Size Is the Same as the Destination Transfer Size

Every time a DMA transfer request is detected, a source read and a destination write occur.

The following figure shows a timing chart where the source transfer size and the destination transfer size are both 8 bits (in the case of rising edge detection, with 1 set in REQD of the CHCFG_n/nS register).

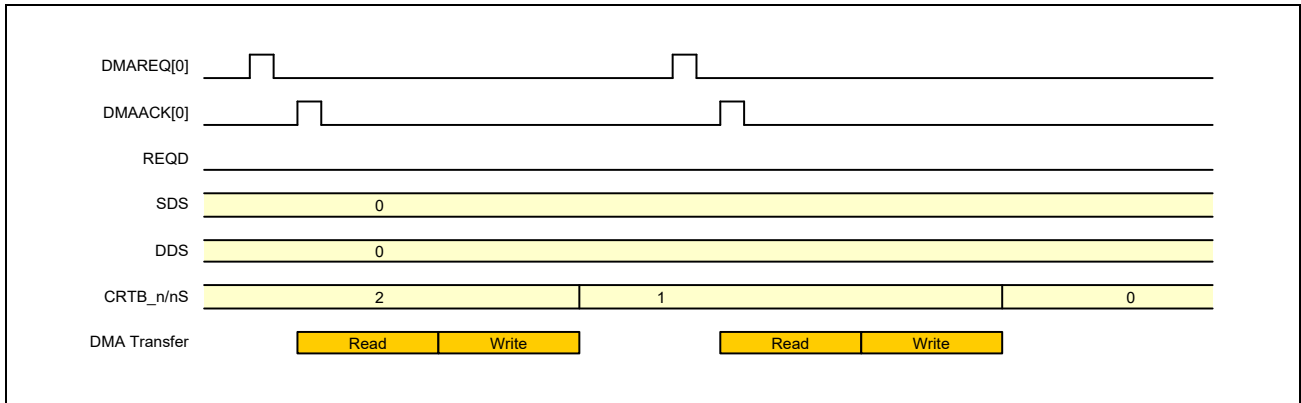

Figure 14.18 When the Source Transfer Size Is the Same as the Destination Transfer Size (LVL = 0, HIEN = 1, REQD = 0, SDS = DDS in CHCFG_n/nS)

14.7.8 Transfer Status

The channel status register indicates the status of DMA transfer execution on a channel.

(1) Suspend

A DMA transfer can be suspended by using the SETSUS bit of CHCTRL_n/nS. In this case, if an ongoing bus cycle exists, the DMAC waits for that cycle to end before suspending the transfer. Writing 1 in the CLRSUS bit restores the DMA transfer from the suspend status.

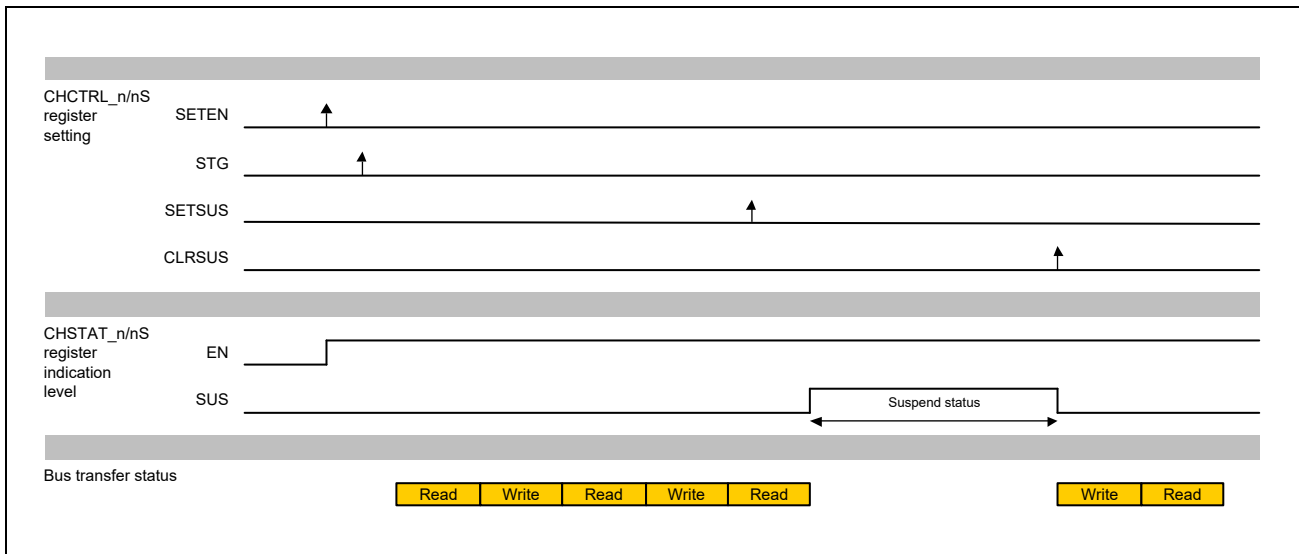

Figure 14.19 DMAC Suspend Status (Auto Request/Block Transfer)

In the above case, the DMA transfer is suspended after the read transfer is completed.

If there is any ongoing DMA transfer, the suspend status starts when that transfer is completed. To make sure that the transfer is suspended, read the CHSTAT or DSTAT_SUS register, after setting SETSUS, and check that 1 is set in the SUS bit for the relevant channel.

(2) Transfer Stop

If 1 is written to CLREN while a DMA transaction is in progress, the DMA transaction for the corresponding channel can be stopped. For the post-stop processing, two modes are supported: one sweeps out the data remaining in the buffer when the transaction is stopped (SBE = 1) and the other does not (SBE = 0). One of these modes can be selected using the SBE bit of the CHCFG_n/nS register. By default, SBE is set to 0.

When this sweep mode is enabled and CLREN is set to 1, and if a DMA transaction is stopped with data remaining in the DMAC buffer, the transaction is completed after the DMAC sweeps the data.

(a) Transfer Stop (Buffer Sweep Disabled - SBE = 0)

If 1 is set in CLREN during a DMA transfer, the DMA transfer is stopped. The stop timing depends on the value set in REQD. After stopping a DMA transfer, be sure to set 1 in SWRST to clear the DMA internal status before setting the next transfer.

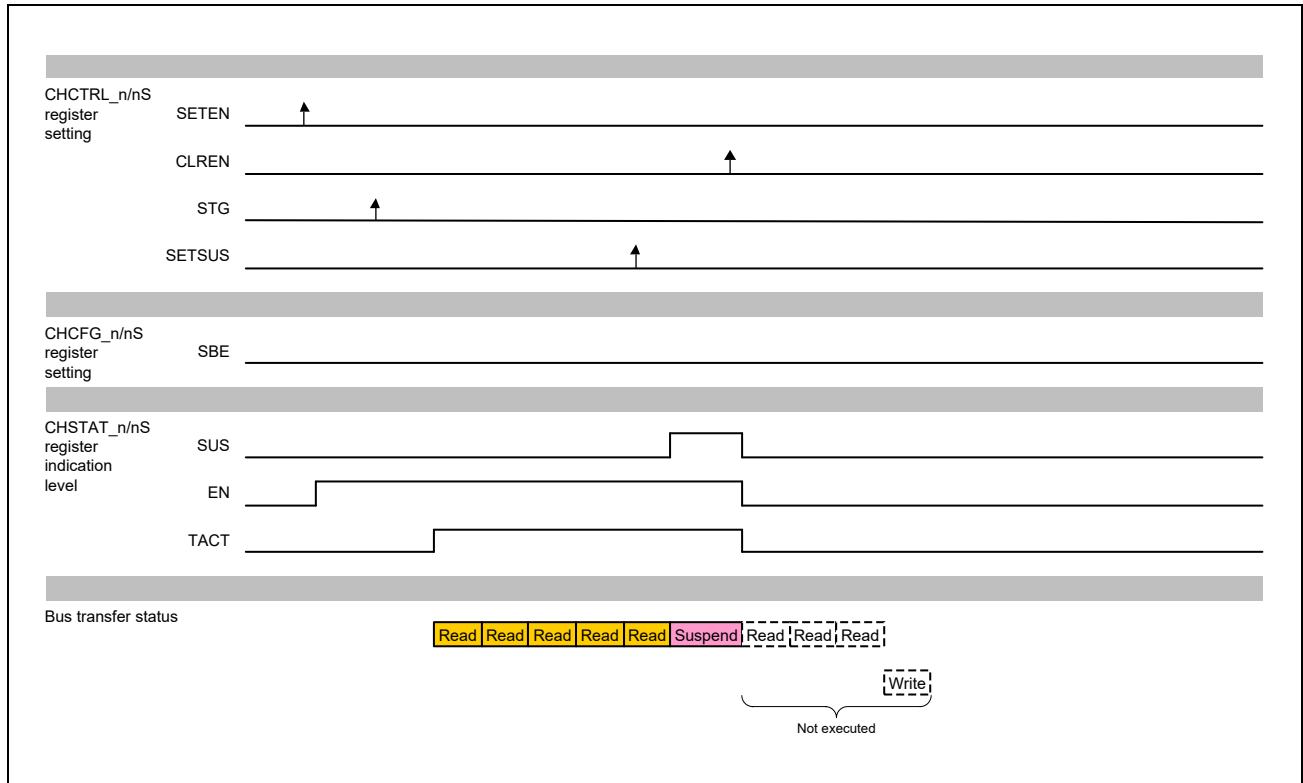

Figure 14.20 DMAC Transfer Stop

- The setting of the TACT bit being 0 indicates that the channel has been brought to a complete stop.
- If an ongoing DMA transfer is stopped before it is completed, the DMA transfer end interrupt is not asserted.
- If 0 is set in REQD, the DMA transfer is stopped when the next read is completed. (If the buffer contains any data that can be written, the DMA transfer is stopped after the data is written.)
- If 1 is set in REQD, the DMA transfer is stopped when the next write is completed.

(b) Transfer Stop (Buffer Sweep Enabled - SBE = 1)

If 1 is set in CLREN during a DMA transfer, the DMA transfer is stopped. When 0 is set in REQD, the DMA transfer is stopped after the DMAC sweeps (writes) the already read data. If 1 is set in REQD to use hardware requests, do not use the sweep mode. After stopping a DMA transfer, be sure to set 1 in SWRST to clear the DMAC internal status before setting the next transfer.

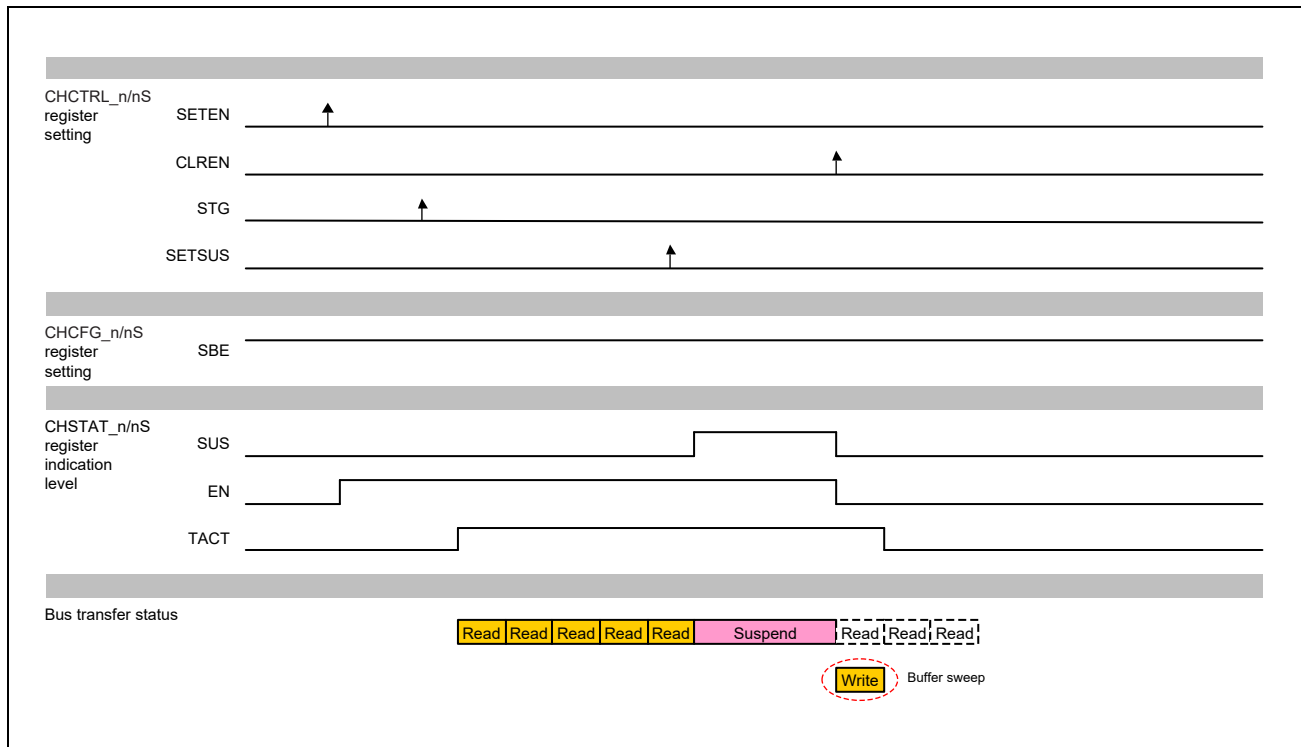

Figure 14.21 DMA Transfer Stop (Buffer Sweep Mode)

- The setting of the TACT bit being 0 indicates that the channel has been brought to a complete stop.
- If a transfer is stopped in sweep mode (SBE = 1) during the fifth read transfer by setting SETSUS and then CLREN, the read data is written before the DMA transfer is stopped.

(c) Channel Stop Check Method

Even when the EN bit is cleared to 0, the DMA transfer cannot be stopped immediately, if the bus is already executing the transfer. Therefore, in order to make sure that the DMAC has been brought to a complete stop, check that the EN bit and TACT bit are both set to 0.

(d) Transfer Stop Procedure

The transfer stop procedure is described below.

1. Set 1 in SETSUS of CHCTRL_n/nS.
2. Repeat polling until the SUS bit of CHSTAT_n/nS is set to 1. (If EN is already set to 0, the DMAC has already been stopped. Go to step 6.)
3. Set 1 in CLREN of CHCTRL_n/nS.

4. When 0 is set in SBE, the transfer is stopped according to the value of REQD. When 1 is set in SBE, the sweep mode is enabled. When 1 is set in SBE, set 0 in REQD.
5. Read CHSTAT_n/nS to check that 0 is set in the TACT bit. When TACT is set to 0, it means that the DMAC has been brought to a complete stop. When TACT is set to 1, repeat polling until this bit is set to 0.
6. To execute the next DMA transfer after stopping a transfer, be sure to set 1 in the SWRST (software reset) bit of CHCTRL_n/nS before the next DMA transfer starts.

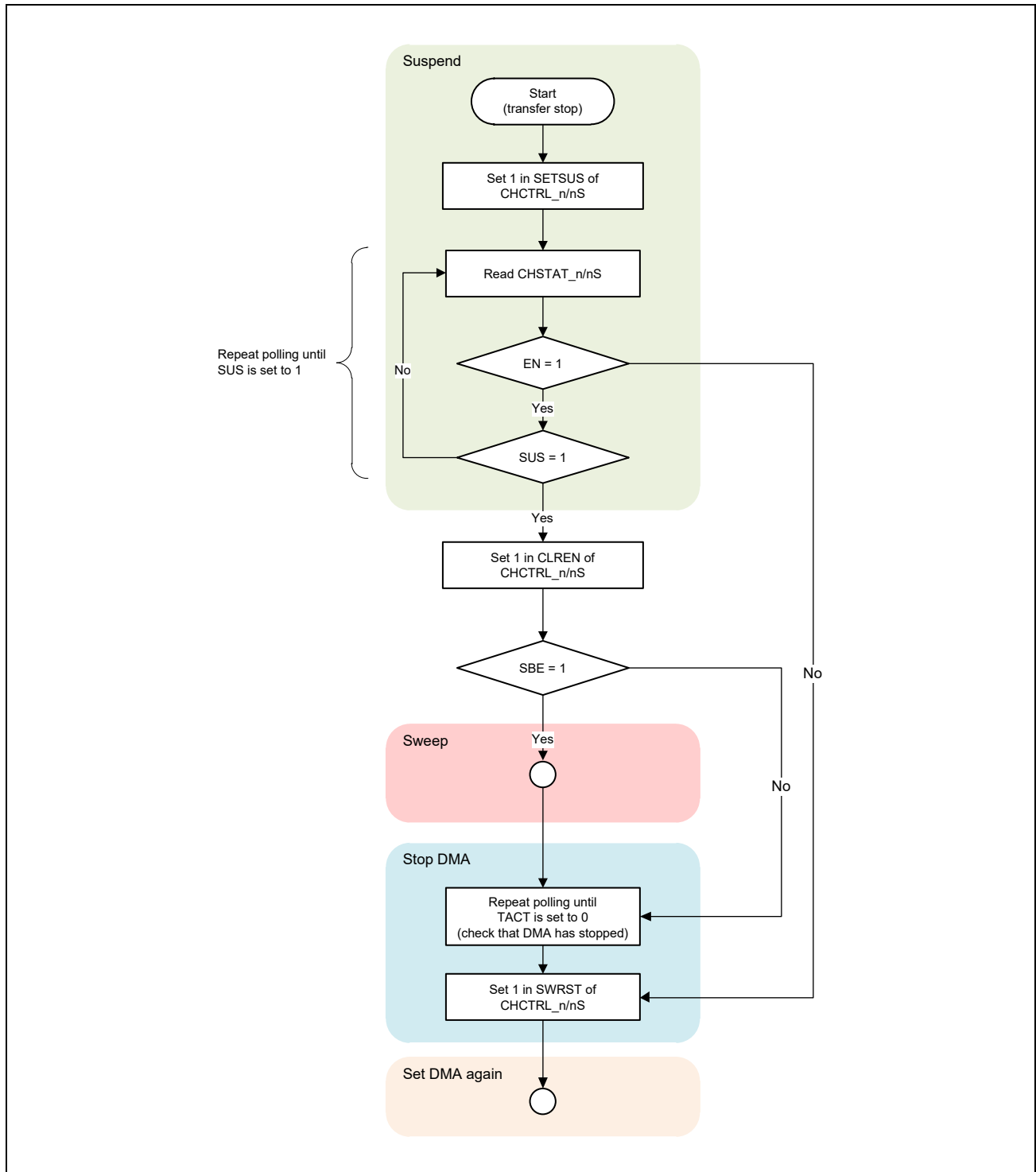

Figure 14.22 Transfer Stop Flow

14.8 DMA Setting Examples

Setting examples applicable when DMA transfer is executed using the direct memory access controller are shown in the following.

The transfer conditions for these setting examples are as follows.

Table 14.18 Transfer Condition List for DMA Transfer Setting Examples

	DMA Mode	Transfer Mode	Transfer Request
Setting example 1	Register	Single	Hardware
Setting example 2	Register	Block	Software
Setting example 3	Register (continuous execution)	Block	Software
Setting example 4	Link	Block	Software

For details of the settings, see the individual setting examples.

14.8.1 Setting Example 1 (Register Mode/Hardware Request)

The following table shows a setting example applicable when DMA transfer is executed using the settings shown below.

Table 14.19 DMA Transfer Setting Example 1

Item	Description	
Channel used	3	
DMA mode	Register	
Transfer mode	Single transfer	
Register set used	Next0	
Source/destination	Source	Destination
	Start address	H'11110000
	Address direction	Increment
	Data size	32 bits
DMA transfer byte count	64 bytes	
DMA transfer request	Rising edge detection by hardware	
DMAACK signal	Level output during read	
DMA transfer end interrupt mask	Not masked	
CACHE setting	Default value	

Setting example 1

N0SA = H'11110000 (source address)

N0DA = H'22220000 (destination address)

N0TB = H'00000040 (transfer byte count)

CHCFG = H'00022123 (configuration)

CHITVL = H'00000000 (interval)

CHEXT = H'00000000 (CACHE setting)

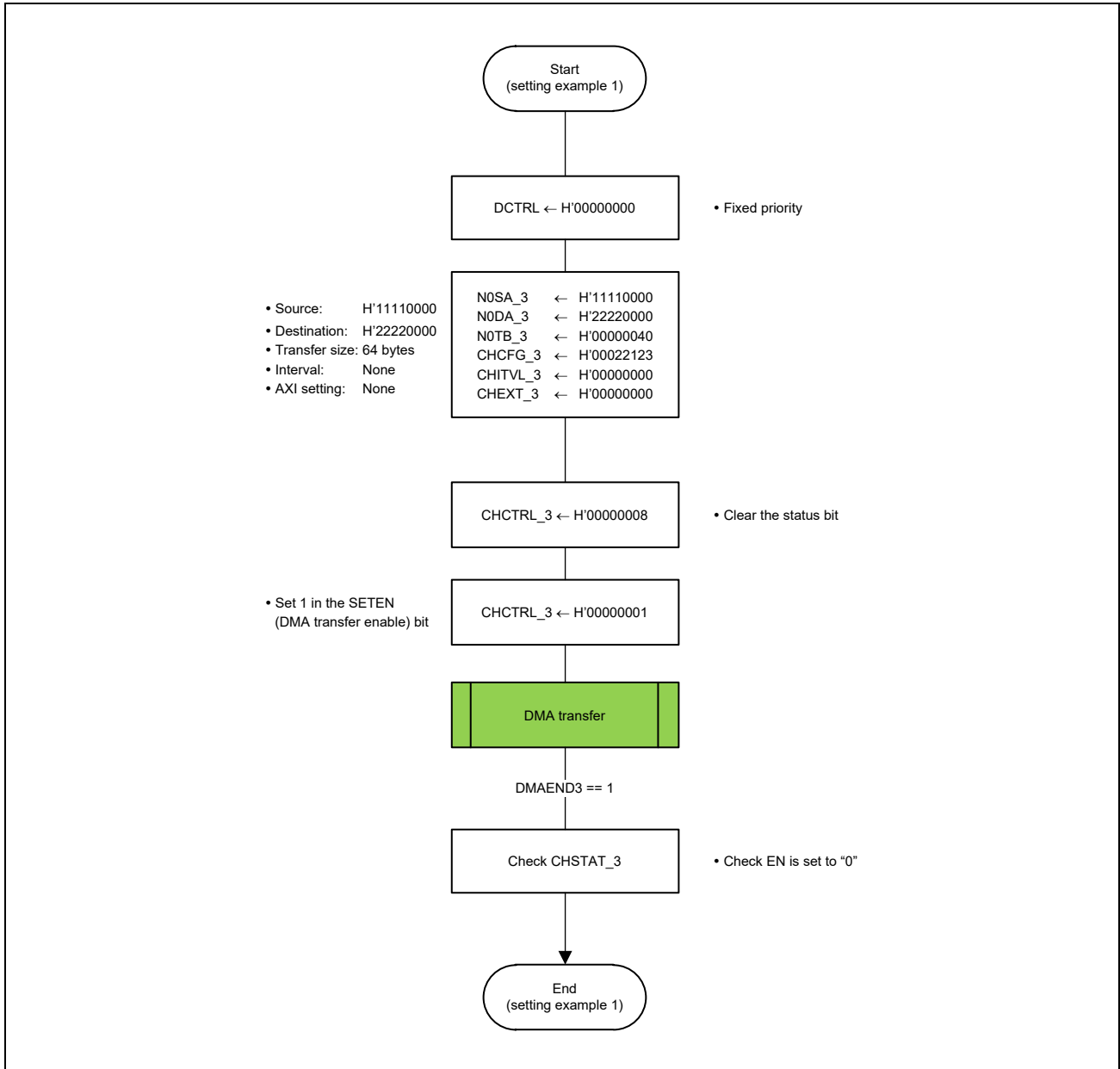

Figure 14.23 Setting Example 1

14.8.2 Setting Example 2 (Register Mode/Software Request)

The following table shows a setting example applicable when DMA transfer is executed using the settings shown below.

Table 14.20 DMA Transfer Setting Example 2

Item	Description	
Channel used	2	
Priority control	Round robin	
DMA mode	Register	
Transfer mode	Block transfer	
Register set used	Next1	
Source/destination	Source	Destination
	Start address	H'0FFFE000
	Address direction	Increment
	Data size	8 bits
DMA transfer byte count	128 bytes	
DMA transfer request	Auto request	
DMAACK signal	Masked	
DMA transfer end interrupt mask	Not masked	
CACHE setting	Default value	

Setting example 2

DCTRL = H'00000001 (DMA setting)

N1SA = H'0FFFE000 (source address)

N1DA = H'33330000 (destination address)

N1TB = H'00000080 (transfer byte count)

CHCFG = H'10450402 (configuration)

CHITVL = H'00000000 (interval)

CHEXT = H'00000000 (CACHE setting)

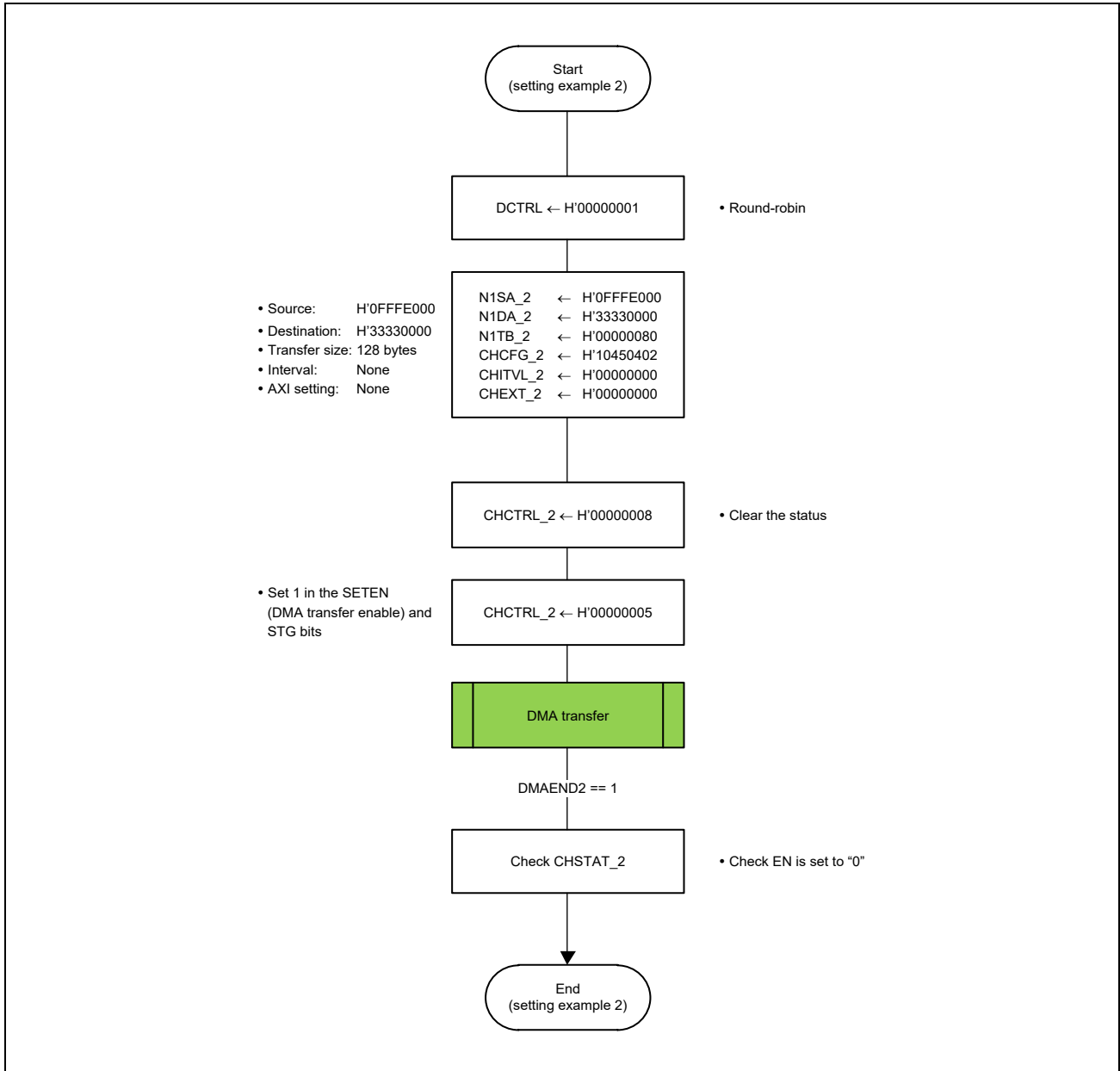

Figure 14.24 Setting Example 2

14.8.3 Setting Example 3 (Register Mode/Continuous Execution)

The following table shows a setting example applicable when DMA transfer is executed using the settings shown below.

Table 14.21 DMA Transfer Setting Example 3

Item	Description		
Channel used	1		
Priority control	Round robin		
DMA mode	Register		
Transfer mode	Block transfer		
Register set used	Use Next0 and then Next1 continuously		
Next0	Source	Destination	
	Start address	H'11110000	H'33330000
	Address direction	Fixed	Fixed
	Data size	32 bits	512 bits
	DMA transfer byte count	512 bytes	
Next1	Source	Destination	
	Start address	H'22220000	H'44440000
	Address direction	Fixed	Fixed
	Data size	32 bits	512 bits
	DMA transfer byte count	2048 bytes	
DMA transfer request	Auto request		
DMAACK signal	Not output		
DMA transfer end interrupt mask	Mask the DMA transfer end interrupt upon completion of Next0		
CACHE setting	Default value		

Setting example 3

DCTRL = H'00000001 (DMA setting)

N0SA = H'11110000 (source address)

N0DA = H'33330000 (destination address)

N0TB = H'00000200 (transfer byte count)

N1SA = H'22220000 (source address)

N1DA = H'44440000 (destination address)

N1TB = H'00000800 (transfer byte count)

CHCFG = H'61762001 (configuration)

CHITVL = H'00000000 (interval)

CHEXT = H'00000000 (CACHE setting)

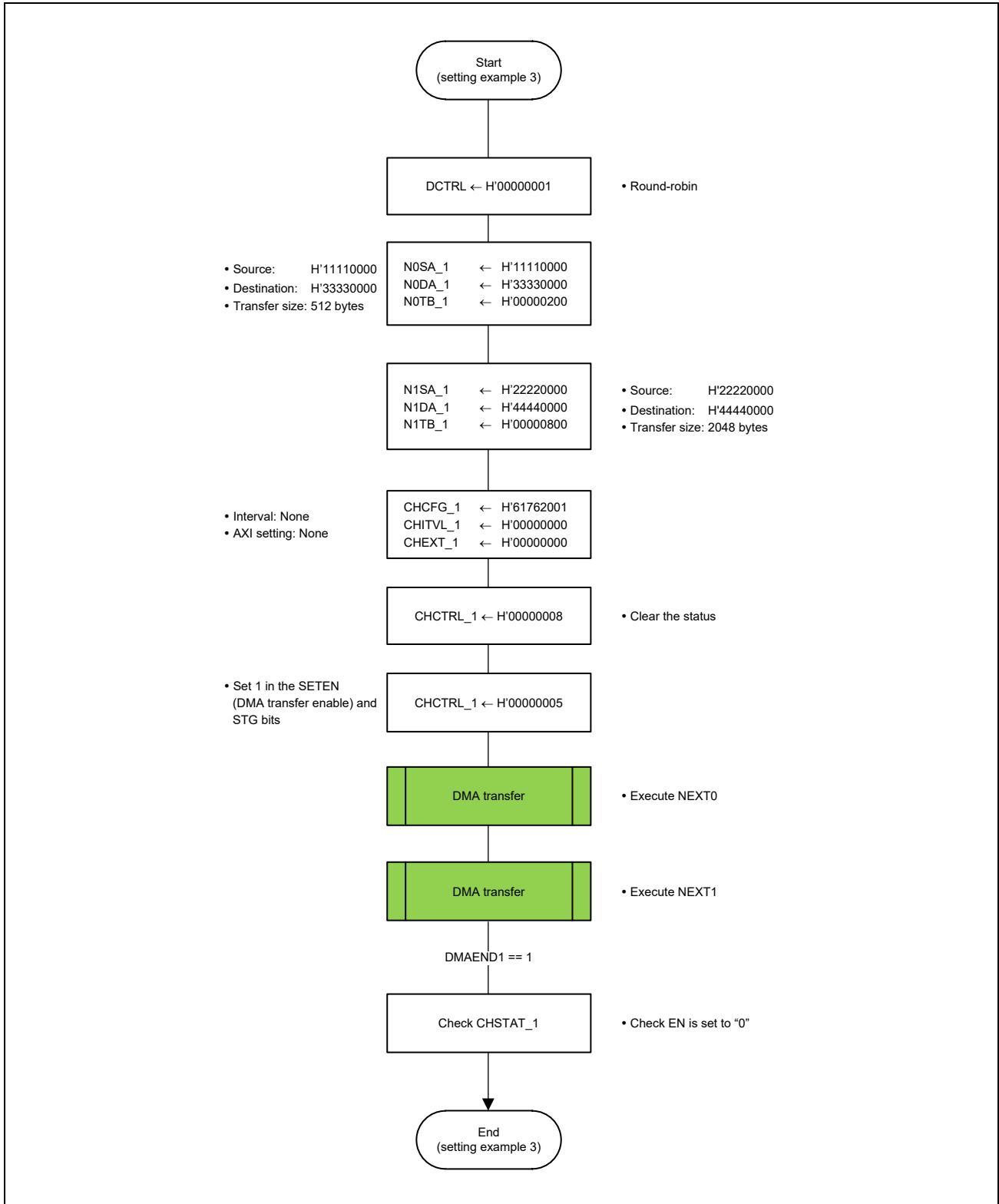

Figure 14.25 Setting Example 3

14.8.4 Setting Example 4 (Link Mode)

The following table shows a setting example applicable when DMA transfer is executed using the settings shown below.

Table 14.22 DMA Transfer Setting Example 4

Item	Description
Channel used	0
Priority control	Round robin
DMA mode	Link
Transfer mode	Block transfer
Register set used	—
Descriptor start address	H'00001000

Table 14.23 DMA Transfer Setting Example 4 (Descriptor 1)

Item	Description		
Descriptor start address	H'00001000		
Next descriptor start address	H'00002000		
Transfer mode	Block transfer		
Next0	Source	Destination	
	Start address	H'11110000	H'33330000
	Address direction	Increment	Increment
	Data size	32 bits	32 bits
DMA transfer byte count	2048 bytes		
DMA transfer request	Auto request trigger (STG)		
DMAACK signal	Not output		
DMA transfer end interrupt mask	Masked		
CACHE setting	Default value		
header			
	DMA interrupt when LV = 1	Issued (DIM = 0)	
	LV writeback	Done (WBD = 0)	
	Next link address	Available (LE = 0)	
Descriptor valid	Valid (LV = 1)		

Table 14.24 DMA Transfer Setting Example 4 (Descriptor 2)

Item	Description		
Descriptor start address	H'00002000		
Next descriptor start address	H'00005000		
Transfer mode	Block transfer		
Next0	Source	Destination	
	Start address	H'44440000	H'55550000
	Address direction	Increment	Increment
	Data size	64 bits	256 bits
DMA transfer byte count	1024 bytes		
DMA transfer request	Auto request trigger (STG)		
DMAACK signal	Not output		
DMA transfer end interrupt mask	Masked		
CACHE setting	Default value		
header			
	DMA interrupt when LV = 1	Issued (DIM = 0)	
	LV writeback	Done (WBD = 0)	
	Next link address	Available (LE = 0)	
	Descriptor valid	Valid (LV = 1)	

Table 14.25 DMA Transfer Setting Example 4 (Descriptor 3)

Item	Description		
Descriptor start address	H'00005000		
Next descriptor start address	—		
Transfer mode	Block transfer		
Next0	Source	Destination	
	Start address	H'77770000	H'AAAA0000
	Address direction	Increment	Increment
	Data size	512 bits	512 bits
DMA transfer byte count	4096 bytes		
DMA transfer request	Auto request trigger (STG)		
DMAACK signal	Not output		
DMA transfer end interrupt mask	Not masked		
CACHE setting	Default value		
header			
	DMA interrupt when LV = 1	Issued (DIM = 0)	
	LV writeback	Done (WBD = 0)	
	Next link address	Not available (LE = 1)	
	Descriptor valid	Valid (LV = 1)	

Setting example 4

DCTRL= H'00000001 (DMA setting)

NXLA = H'00001000 (descriptor start address)

CHCFG = H'80000000 (configuration)

Table 14.26 Descriptor Setting

	Descriptor 1	Descriptor 2	Descriptor 3
header	H'00000001	H'00000001	H'00000003
SA (Source Address)	H'11110000	H'44440000	H'77770000
DA (Destination Address)	H'33330000	H'55550000	H'AAAA0000
TB (Transaction Byte)	H'00000800	H'00000400	H'00001000
CFG (Configuration)	H'81422008	H'81453008	H'80466008
ITVL (Interval)	H'00000000	H'00000000	H'00000000
EXT (Extension)	H'00000000	H'00000000	H'00000000
NXLA (Next Link Address)	H'00002000	H'00005000	H'00000000

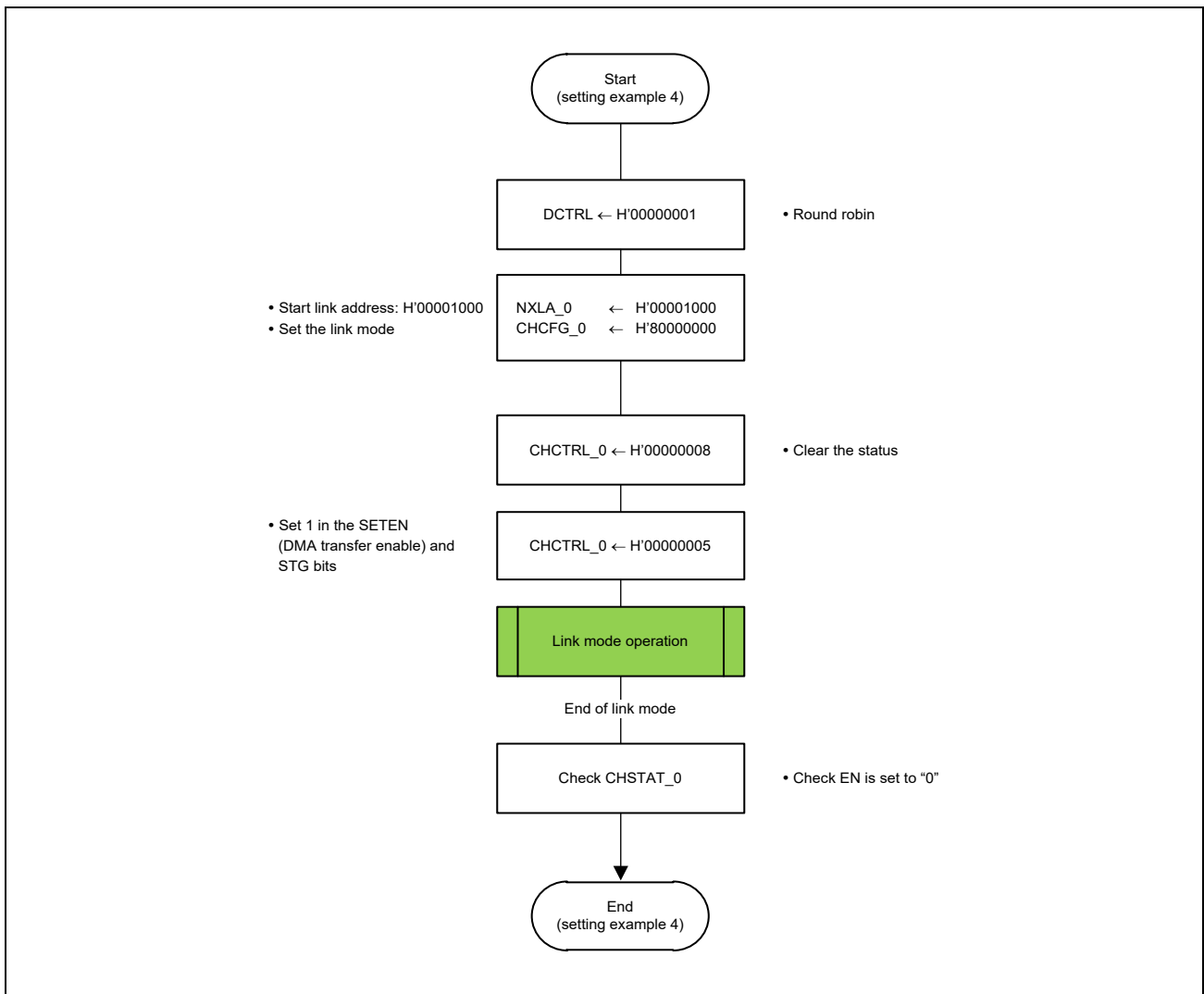

Figure 14.26 Setting Example 4

14.8.5 Next Register Set Continuous Execution Setting

The following figure shows the flowchart for executing DMA transfers continuously by using two Next register sets in register mode. While a DMA transaction is being executed using one Next register set, the other Next register set is set in order to continue to execute DMA transfers.

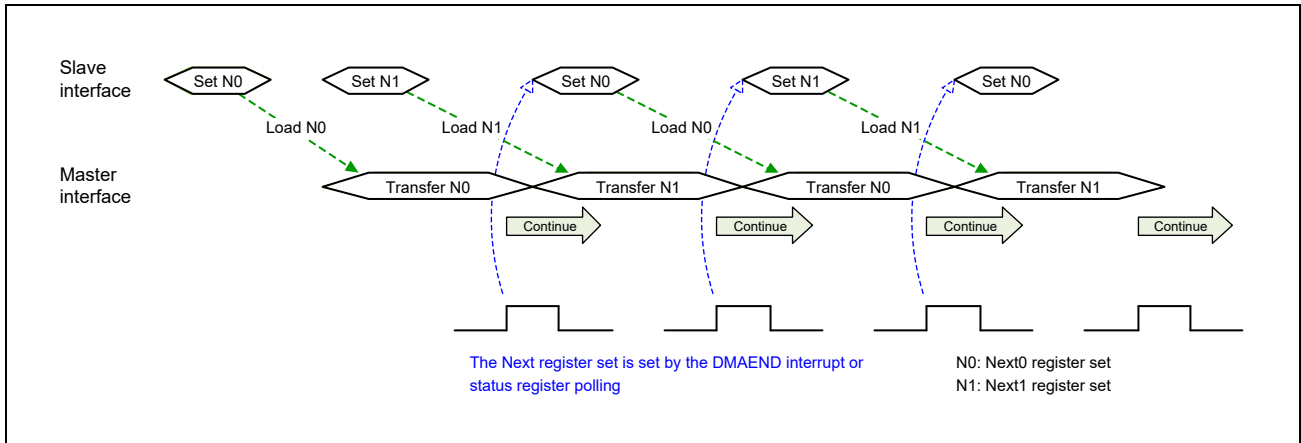

Figure 14.27 Image of Next Register Set Continuous Execution

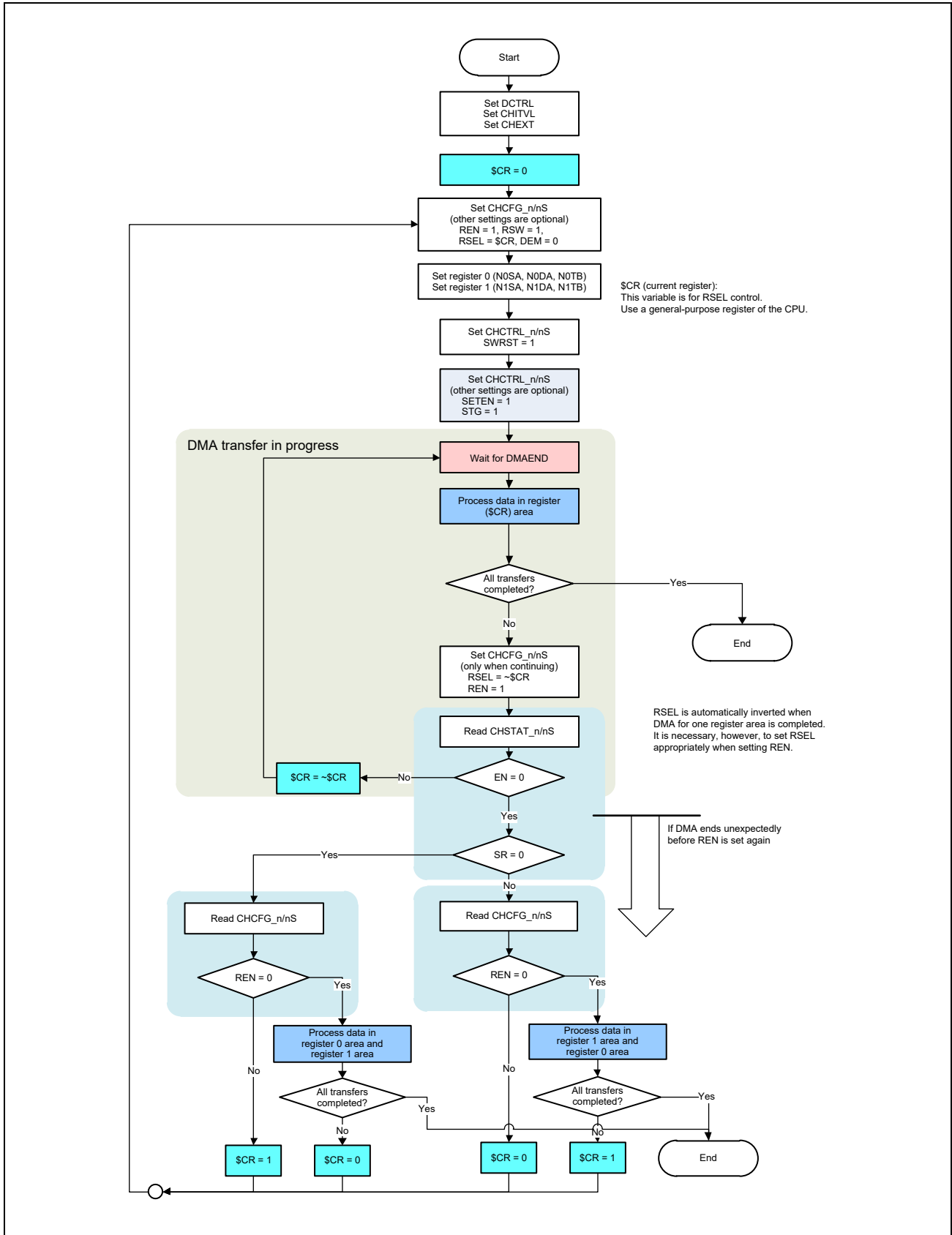

Figure 14.28 Example of Continuous DMA Execution by Using a Next Register Set

- Supplementary information

First, save the data of the register sets to be used for DMA transfers (0 (N0SA, N0DA, and N0TB) and 1 (N1SA, N1DA, and N1TB)) to a general-purpose register of the CPU (the values of this register is referred to as \$CR for the sake of convenience).

Each time the DMA transfers for one register set are completed (the DMA transfer end interrupt is output), REN is automatically cleared to 0. In order to continue to execute DMA transfers, it is necessary to set REN of the CHCFG_n/nS register every time the DMA transfer end interrupt is asserted. This register also contains the RSEL bit, and the value of this bit needs to be set appropriately as well. Therefore, use \$CR.

In this mode, two Next register sets are executed continuously. However, if CLREN is not set before the DMA transaction is completed (the next DMA transfer end interrupt is output), continuous execution stops. In this case, how much of data has been transferred can be checked by reading the SR and EN bits of the CHSTAT_n/nS register and the REN bit of the CHCFG_n/nS register. To restart the DMA transaction, follow the flowchart shown above.

14.9 Points for Caution

14.9.1 Problem of the Interrupt Signal Overtaking DMA Transfer

14.9.1.1 Overview

This unit asserts the DMAINT interrupt signal on completion of transfer and this serves as a trigger for the CPU to start processing the data.

However, in cases such as where the device for writing is on another bus, the final data to be written may not yet have reached the device for writing at the time the DMAINT interrupt signal is asserted.

If the CPU accesses a device that has detected the DMAINT interrupt signal before the final data of the DMA transaction have been written to the device, it may be using some old data from before the writing.

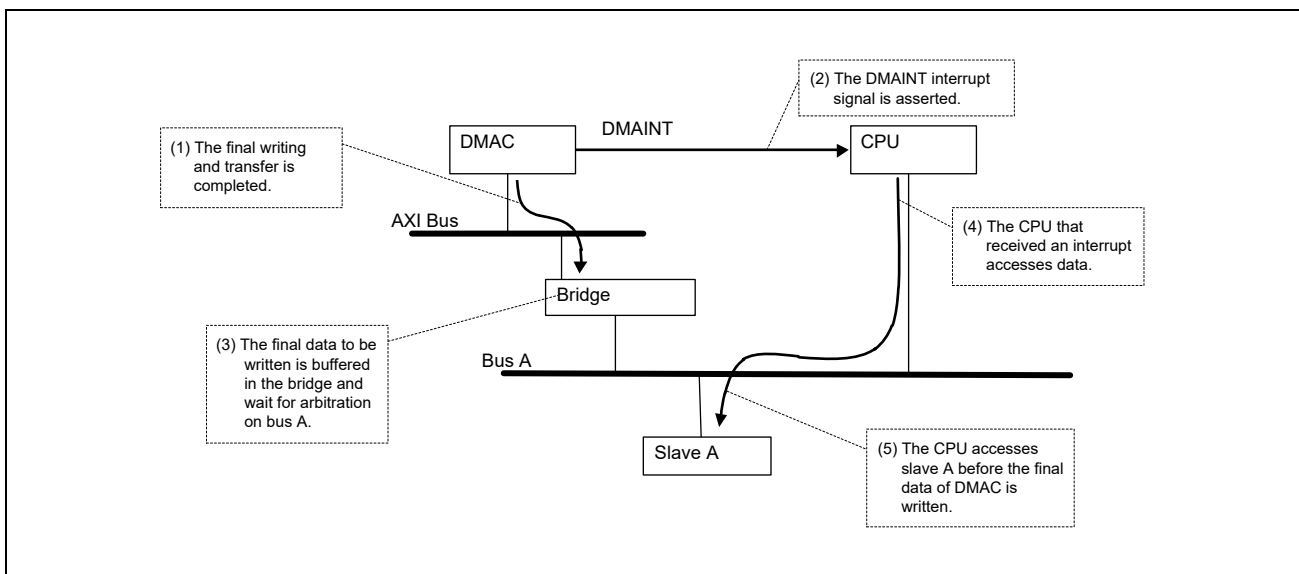

Figure 14.29 Example when Access by the CPU Overtakes Writing of the Final Data by the DMAC

14.9.1.2 Workaround

The following describes workaround for the above problems.

Setting AWCACHE as non-bufferable

Set the AWCACHE signal as non-bufferable for DMA transactions. By doing this, the above problems can be avoided because the DMAINT interrupt signal will only be asserted after the completion of writing to the device for access.

Setting all transfers to non-bufferable may reduce the efficiency of transfer. In such cases, divide up the register sets or descriptors by setting most of the transactions to bufferable for transfer, and then set only the last transfer to non-bufferable.

Exception)

The effect is not obtained if the device in the access path does not refer to AWCACHE.

15. Machine Timer

A Machine Timer provides a real-time counter and generates timer interrupt. See the AndesCore™ AX45MP-1C Processor Reference Manual for more detail.

15.1 Features

- 64bit machine timer
- Machine Timer clock: 12 MHz
- 64bit data bus

The following figure shows the connection between Machine Timer and related modules.

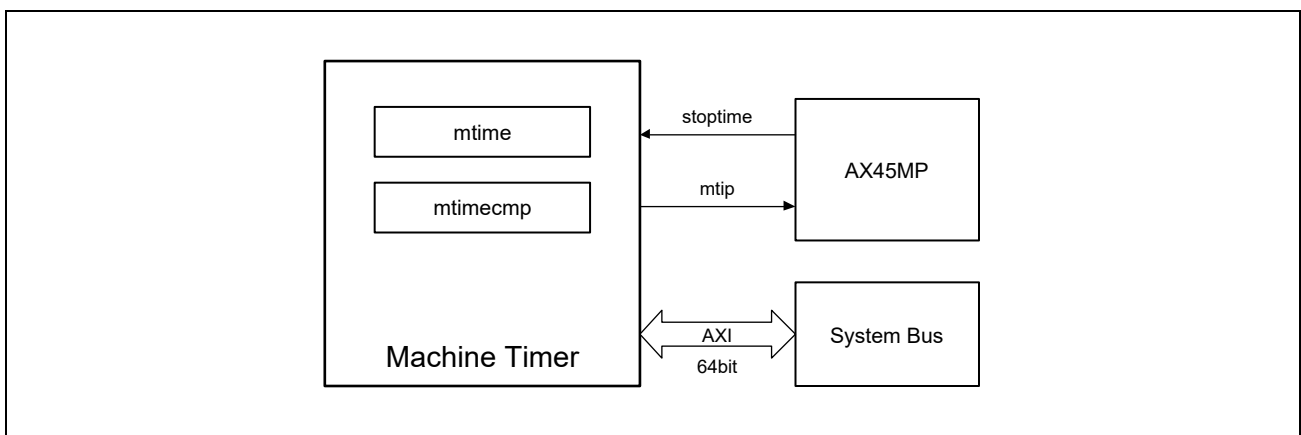

Figure 15.1 Connection between Machine Timer and related modules

stoptime: Stop counting the mtime counter in Debug Mode.

mtip: Timer interrupt pending.

mtime: The mtime register is a 64-bit real-time counter clocked by Machine Timer clock.

mtimecmp: The mtimecmp register stores a 64-bit value for comparing with mtime

See the AndesCore™ AX45MP-1C Processor Reference Manual for detail.

15.2 Register Configuration

Base Address: H'0_1100_0000

The following table shows a machine timer register list.

Table 15.1 Register List

Register Name	Abbreviation	R/W	Initial Value	Address	Access Size
mtime[31:0]	MT_L	R/W	H'0000_0000	H'0	32/64
mtime[63:32]	MT_H	R/W	H'0000_0000	H'4	32/64
mtimecmp0[31:0]	MTCMP_L	R/W	H'0000_0000	H'8	32/64
mtimecmp0[63:32]	MTCMP_H	R/W	H'0000_0000	H'C	32/64

15.3 Register Descriptions

See the AndesCore™ AX45MP-1C Processor Reference Manual.

16. Multi-Function Timer Pulse Unit 3 (MTU3a)

16.1 Overview

This LSI has an on-chip multi-function timer pulse unit 3 (MTU3a), consisting of eight 16-bit timer channels and one 32-bit timer channel.

Table 16.1 shows the specifications of the MTU and **Table 16.2** lists the functions of the MTU. **Figure 16.1** and **Figure 16.2** are block diagrams of the MTU.

Table 16.1 MTU Specifications (1/2)

Item	Description
Pulse input/output	28 lines max.
Pulse input	3 lines
Count clock	11 clocks for each channel (14 clocks for MTU0, 12 clocks for MTU2, and 10 clocks for MTU5, four clocks for MTU1-MTU2 combination (when LWA = 1))
Operating frequency	Up to 100 MHz
Available operations	<p>[MTU0 to MTU4, MTU6, MTU7, and MTU8]</p> <ul style="list-style-type: none"> • Waveform output on compare match • Input capture function (noise filter setting available) • Counter-clearing operation • Simultaneous writing to multiple timer counters (TCNT) (excluding MTU8) • Simultaneous clearing on compare match or input capture (excluding MTU8) • Simultaneous input and output to registers in synchronization with counter operations (excluding MTU8) • Up to 12-phase PWM output in combination with synchronous operation (excluding MTU8) <p>[MTU0 MTU3, MTU4, MTU6, MTU7, and MTU8]</p> <ul style="list-style-type: none"> • Buffer operation specifiable <p>[MTU1, MTU2]</p> <ul style="list-style-type: none"> • Phase counting mode can be specified independently • 32-bit phase counting mode can be specified for interlocked operation of MTU1 and MTU2 (when TMDR3.LWA = 1) • Cascade connection operation available <p>[MTU3, MTU4, MTU6, and MTU7]</p> <ul style="list-style-type: none"> • Through interlocked operation of MTU3/4 and MTU6/7, the positive and negative signals in six phases (12 phases in total) can be output in complementary PWM and reset-synchronized PWM operation. • In complementary PWM mode, values can be transferred from buffer registers to temporary registers at crests and troughs of the timer-counter values or when the buffer registers (TGRD registers in MTU4 and MTU7) are written to. • Double-buffering selectable in complementary PWM mode <p>[MTU3 and MTU4]</p> <ul style="list-style-type: none"> • Through interlocking with MTU0, a mode for driving AC synchronous motors (brushless DC motors) by using complementary PWM output and reset-synchronized PWM output is settable and allows the selection of two types of waveform output (chopping or level) <p>[MTU5]</p> <ul style="list-style-type: none"> • Capable of operation as a dead-time compensation counter <p>[MTU0/MTU5, MTU1, MTU2, and MTU8]</p> <p>32-bit phase counting mode specifiable by combining MTU1 and MTU2 and through interlocked operation with MTU0/MTU5 and MTU8</p>
Interrupt-skipping function	<ul style="list-style-type: none"> • In complementary PWM mode, interrupts on crests and troughs of counter values and triggers to start conversion by the A/D converter can be skipped
Interrupt sources	43 sources
Buffer operation	Automatic transfer of register data (transfer from the buffer register to the timer register)

Table 16.1 MTU Specifications (2/2)

Item	Description
Trigger generation	A/D converter start triggers can be generated A/D converter start request delaying function enables A/D converter to be started with any desired timing and to be synchronized with PWM output
Low power consumption function	The MTU3a can be placed in the module-stop state.

Table 16.2 MTU Functions (1/2)

Item	MTU0	MTU1	MTU2	MTU1 & MTU2 (LWA = 1)	MTU3	MTU4	MTU5	MTU6	MTU7	MTU8
Count clock	P0φ/1 P0φ/2 P0φ/4 P0φ/8 P0φ/16 P0φ/32 P0φ/64 P0φ/256 P0φ/1024 MTCLKA MTCLKB MTCLKC MTCLKD MTIOC1A	P0φ/1 P0φ/2 P0φ/4 P0φ/8 P0φ/16 P0φ/32 P0φ/64 P0φ/256 P0φ/1024 MTCLKA MTCLKB MTCLKC MTCLKD MTIOC1A	P0φ/1 P0φ/2 P0φ/4 P0φ/8 P0φ/16 P0φ/32 P0φ/64 P0φ/256 P0φ/1024 MTCLKA MTCLKB MTCLKC	MTCLKA MTCLKB MTCLKC MTCLKD	P0φ/1 P0φ/2 P0φ/4 P0φ/8 P0φ/16 P0φ/32 P0φ/64 P0φ/256 P0φ/1024 MTCLKA MTCLKB	P0φ/1 P0φ/2 P0φ/4 P0φ/8 P0φ/16 P0φ/32 P0φ/64 P0φ/256 P0φ/1024 MTCLKA MTCLKB	P0φ/1 P0φ/2 P0φ/4 P0φ/8 P0φ/16 P0φ/32 P0φ/64 P0φ/256 P0φ/1024 MTIOC1A MTCLKB	P0φ/1 P0φ/2 P0φ/4 P0φ/8 P0φ/16 P0φ/32 P0φ/64 P0φ/256 P0φ/1024 MTCLKA MTCLKB	P0φ/1 P0φ/2 P0φ/4 P0φ/8 P0φ/16 P0φ/32 P0φ/64 P0φ/256 P0φ/1024 MTCLKA MTCLKB	P0φ/1 P0φ/2 P0φ/4 P0φ/8 P0φ/16 P0φ/32 P0φ/64 P0φ/256 P0φ/1024 MTCLKA MTCLKB
External clocks in phase-counting mode	—	MTCLKA MTCLKB	MTCLKA MTCLKB MTCLKC MTCLKD	MTCLKA MTCLKB MTCLKC MTCLKD	—	—	—	—	—	—
General registers (TGR)	TGRA TGRB TGRE	TGRA TGRB	TGRA TGRB	TGRALW TGRBLW	TGRA TGRB	TGRA TGRB	TGRU TGRV TGRW	TGRA TGRB	TGRA TGRB	TGRA TGRB
General registers/ buffer registers	TGRC TGRD TGRF	—	—	—	TGRC TGRD TGRE	TGRC TGRD TGRE	—	TGRC TGRD TGRE	TGRC TGRD TGRE	TGRC TGRD
I/O pins	MTIOC0A MTIOC0B MTIOC0C MTIOC0D	MTIOC1A MTIOC1B	MTIOC2A MTIOC2B	MTIOC1A MTIOC1B	MTIOC3A MTIOC3B MTIOC3C MTIOC3D	MTIOC4A MTIOC4B MTIOC4C MTIOC4D	MTIC5U MTIC5V MTIC5W	MTIOC6A MTIOC6B MTIOC6C MTIOC6D	MTIOC7A MTIOC7B MTIOC7C MTIOC7D	MTIOC8A MTIOC8B MTIOC8C MTIOC8D
Counter clear function	TGR compare match or input capture	TGR compare match or input capture	TGR compare match or input capture	TGRALW/ TGRBLW input capture	TGR compare match or input capture	TGR compare match or input capture	TGR compare match or input capture	TGR compare match or input capture	TGR compare match or input capture	TGR compare match or input capture
Compare match output	0 output 1 output Toggle output	✓ ✓ ✓	✓ ✓ ✓	— — —	✓ ✓ ✓	✓ ✓ ✓	— — —	✓ ✓ ✓	✓ ✓ ✓	✓ ✓ ✓
Input capture function	✓	✓	✓	✓ ^{*1}	✓	✓	✓	✓	✓	✓ ^{*2}
Synchronous operation	✓	✓	✓	—	✓	✓	—	✓	✓	—
PWM mode 1	✓	✓	✓	—	✓	✓	—	✓	✓	—
PWM mode 2	✓	✓	✓	—	—	—	—	—	—	—
Complementary PWM mode	—	—	—	—	✓	✓	—	✓	✓	—
Reset-synchronized PWM mode	—	—	—	—	✓	✓	—	✓	✓	—
AC synchronous motor drive mode	✓	—	—	—	✓	✓	—	—	—	—
Phase counting mode	—	✓	✓	✓	—	—	—	—	—	—
Buffer operation	✓	—	—	—	✓	✓	—	✓	✓	✓
Dead time compensation counter function	—	—	—	—	—	—	—	—	—	—
DMAC activation	TGR compare match or input capture	TGR compare match or input capture	TGR compare match or input capture	TGRALW/ TGRBLW input capture	TGR compare match or input capture	TGR compare match or input capture and TCNT overflow/ underflow ^{*3}	TGR compare match or input capture	TGR compare match or input capture	TGR compare match or input capture and TCNT overflow/ underflow ^{*3}	TGR compare match or input capture

Table 16.2 MTU Functions (2/2)

Item	MTU0	MTU1	MTU2	MTU1 & MTU2 (LWA = 1)	MTU3	MTU4	MTU5	MTU6	MTU7	MTU8
A/D converter start trigger	TGRA compare match or input capture TGRE compare match	TGRA compare match or input capture	TGRA compare match or input capture	TGRALW input capture	TGRA compare match or input capture	TGRA compare match or input capture, or TCNT underflow (trough) in complementary PWM mode	—	TGRA compare match or input capture	TGRA compare match or input capture, or TCNT underflow (trough) in complementary PWM mode	—
Interrupt sources	Seven sources • Compare match or input capture 0A • Compare match or input capture 0B • Compare match or input capture 0C • Compare match or input capture 0D • Compare match 0E • Compare match 0F • Overflow	Four sources • Compare match or input capture 1A • Compare match or input capture 1B • Overflow • Underflow	Four sources • Compare match or input capture 2A • Compare match or input capture 2B • Overflow • Underflow	Four sources • Input capture 1A • Input capture 1B • Overflow • Underflow	Five sources • Compare match or input capture 3A • Compare match or input capture 3B • Compare match or input capture 3C • Compare match or input capture 3D • Overflow	Five sources • Compare match or input capture 4A • Compare match or input capture 4B • Compare match or input capture 4C • Compare match or input capture 4D • Overflow or underflow ³	Three sources • Compare match or input capture 5U • Compare match or input capture 5V • Compare match or input capture 5W	Five sources • Compare match or input capture 6A • Compare match or input capture 6B • Compare match or input capture 6C • Compare match or input capture 6D • Overflow	Five sources • Compare match or input capture 7A • Compare match or input capture 7B • Compare match or input capture 7C • Compare match or input capture 7D • Overflow or underflow ³	Five sources • Compare match or input capture 8A • Compare match or input capture 8B • Compare match or input capture 8C • Compare match or input capture 8D • Overflow
A/D converter start request delaying function	—	—	—	—	—	• A/D converter start request at a match between TADCORA and TCNT or A/D converter start request at a match between TADCORB and TCNT	—	—	• A/D converter start request at a match between TADCORA and TCNT or A/D converter start request at a match between TADCORB and TCNT	—
Interrupt skipping 1	—	—	—	—	• Skips TGRA compare match interrupts	• Skips TCIV interrupts	—	• Skips TGRA compare match interrupts	• Skips TCIV interrupts	—
Interrupt skipping 2	—	—	—	—	—	• Skipping in compare count between TADCORA and TCNT, and TADCORB and TCNT	—	—	• Skipping in compare count between TADCORA and TCNT, and TADCORB and TCNT	—

Remarks: ✓: Possible —: Not possible

Note 1. When LWA is 1, the TGRALW capture source can be selected from either of the following: an input from MTIOC1A or MTU0.TGRA compare match/input capture event.
The TGRBLW capture source can be selected from any of the following: an input from MTIOC1B, MTU0.TGRC compare match/ input capture event, or MTU8.TGRC compare match event.

Note 2. Capture in MTU8 is supported only in normal mode.

Note 3. The underflow interrupt source is valid only in complementary PWM mode.

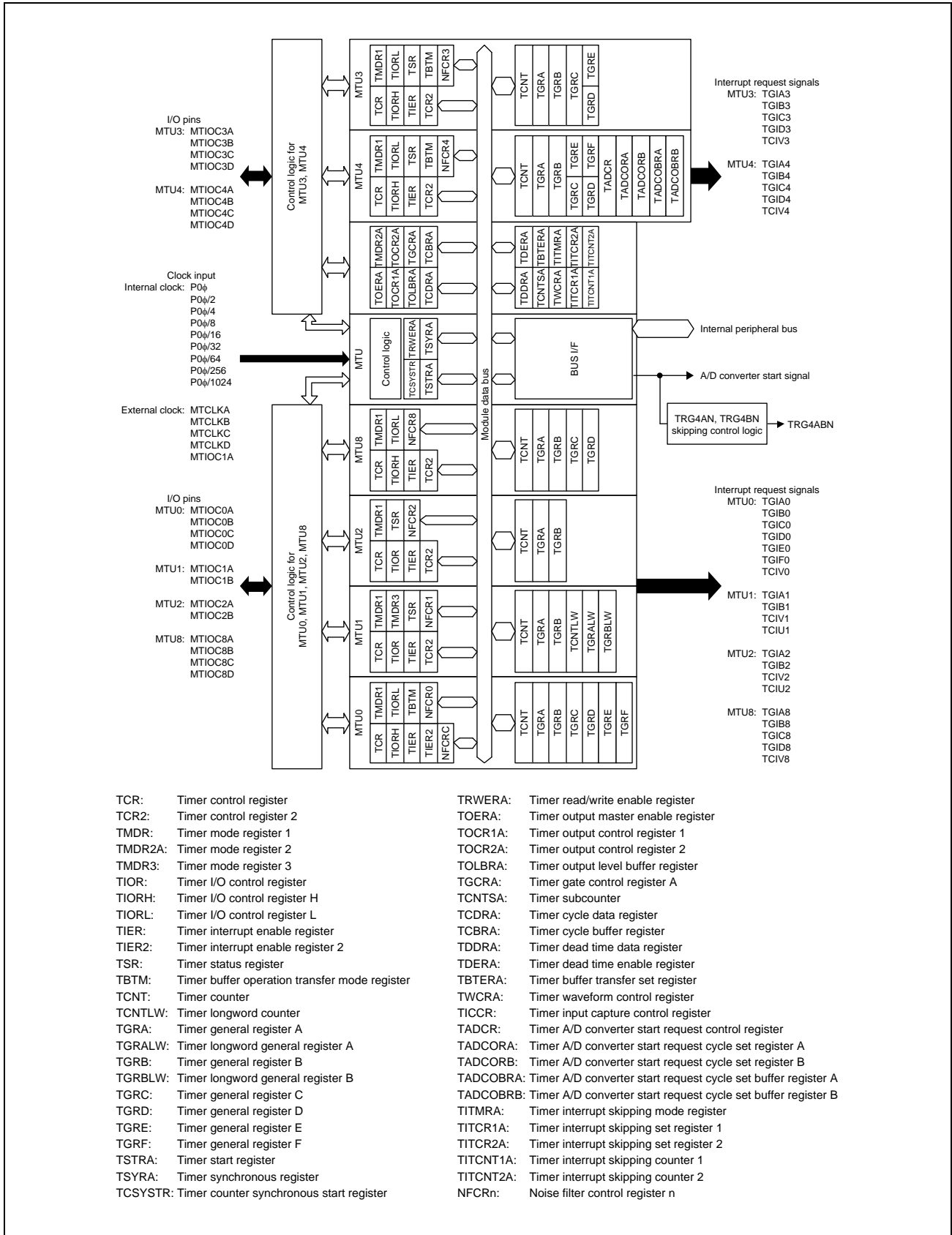

Figure 16.1 Block Diagram of MTU (MTU0 to MTU4, MTU8)

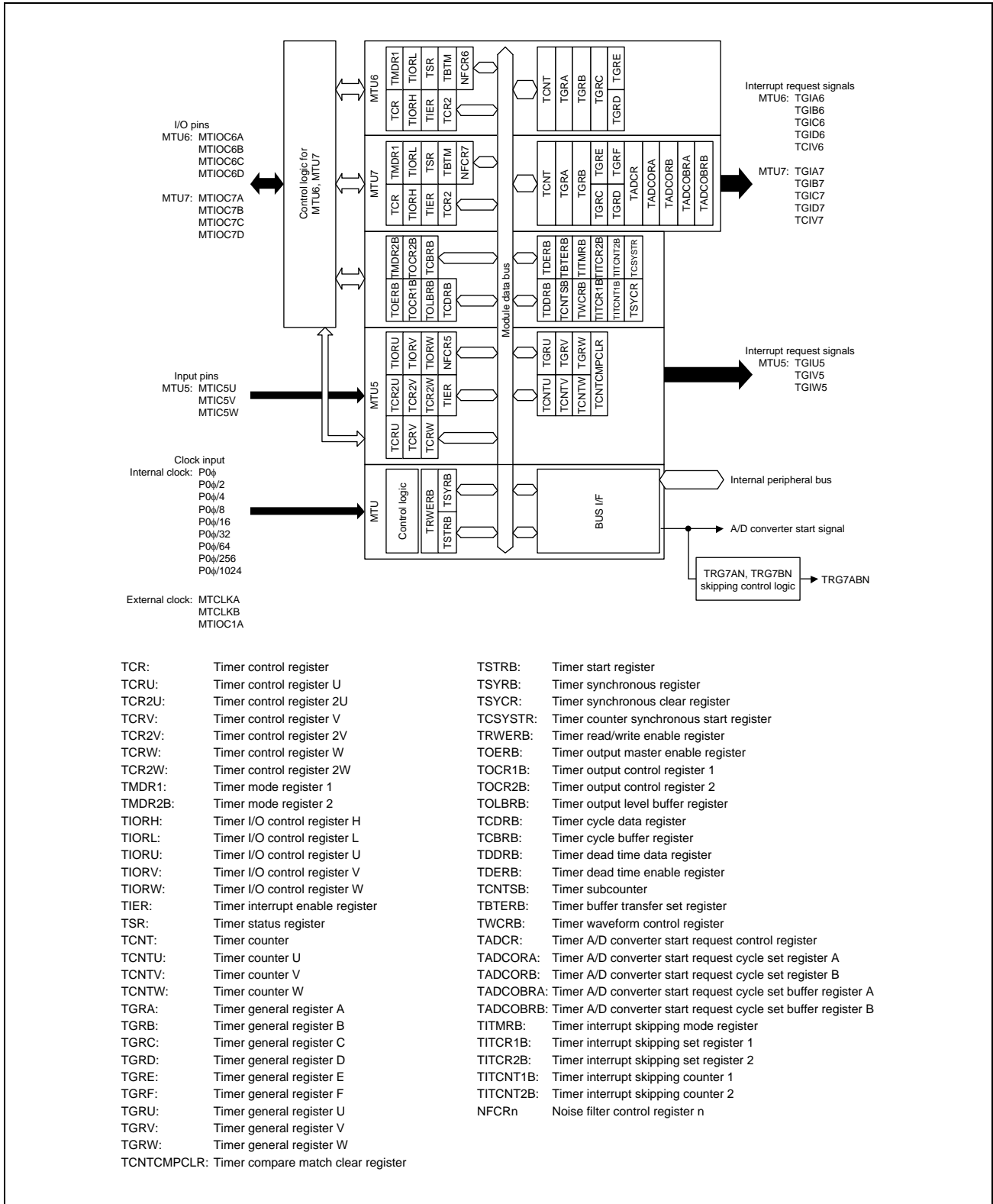

Figure 16.2 Block Diagram of MTU (MTU5 to MTU7)

Table 16.3 shows the configuration of pins for the MTU.

Table 16.3 Pin Configuration of the MTU

Channel	Pin Name	I/O	Function
MTU	MTCLKA	Input	External clock A input pin (MTU1/MTU2 phase counting mode A phase input)
	MTCLKB	Input	External clock B input pin (MTU1/MTU2 phase counting mode B phase input)
	MTCLKC	Input	External clock C input pin (MTU2 phase counting mode A phase input)
	MTCLKD	Input	External clock D input pin (MTU2 phase counting mode B phase input)
MTU0	MTIOC0A	I/O	MTU0 TGRA input capture input/output compare output/PWM output pin
	MTIOC0B	I/O	MTU0 TGRB input capture input/output compare output/PWM output pin
	MTIOC0C	I/O	MTU0 TGRC input capture input/output compare output/PWM output pin
	MTIOC0D	I/O	MTU0 TGRD input capture input/output compare output/PWM output pin
MTU1	MTIOC1A	I/O	MTU1 TGRA input capture input/output compare output/PWM output pin
	MTIOC1B	I/O	MTU1 TGRB input capture input/output compare output/PWM output pin
MTU2	MTIOC2A	I/O	MTU2 TGRA input capture input/output compare output/PWM output pin
	MTIOC2B	I/O	MTU2 TGRB input capture input/output compare output/PWM output pin
MTU3	MTIOC3A	I/O	MTU3 TGRA input capture input/output compare output/PWM output pin
	MTIOC3B	I/O	MTU3 TGRB input capture input/output compare output/PWM output pin
	MTIOC3C	I/O	MTU3 TGRC input capture input/output compare output/PWM output pin
	MTIOC3D	I/O	MTU3 TGRD input capture input/output compare output/PWM output pin
MTU4	MTIOC4A	I/O	MTU4 TGRA input capture input/output compare output/PWM output pin
	MTIOC4B	I/O	MTU4 TGRB input capture input/output compare output/PWM output pin
	MTIOC4C	I/O	MTU4 TGRC input capture input/output compare output/PWM output pin
	MTIOC4D	I/O	MTU4 TGRD input capture input/output compare output/PWM output pin
MTU5	MTIC5U	Input	MTU5 TGRU input capture input/external pulse input pin
	MTIC5V	Input	MTU5 TGRV input capture input/external pulse input pin
	MTIC5W	Input	MTU5 TGRW input capture input/external pulse input pin
MTU6	MTIOC6A	I/O	MTU6 TGRA input capture input/output compare output/PWM output pin
	MTIOC6B	I/O	MTU6 TGRB input capture input/output compare output/PWM output pin
	MTIOC6C	I/O	MTU6 TGRC input capture input/output compare output/PWM output pin
	MTIOC6D	I/O	MTU6 TGRD input capture input/output compare output/PWM output pin
MTU7	MTIOC7A	I/O	MTU7 TGRA input capture input/output compare output/PWM output pin
	MTIOC7B	I/O	MTU7 TGRB input capture input/output compare output/PWM output pin
	MTIOC7C	I/O	MTU7 TGRC input capture input/output compare output/PWM output pin
	MTIOC7D	I/O	MTU7 TGRD input capture input/output compare output/PWM output pin
MTU8	MTIOC8A	I/O	MTU8.TGRA input capture input/output compare output pin
	MTIOC8B	I/O	MTU8.TGRB input capture input/output compare output pin
	MTIOC8C	I/O	MTU8.TGRC input capture input/output compare output pin
	MTIOC8D	I/O	MTU8.TGRD input capture input/output compare output pin

16.2 Register Descriptions

Table 16.4 shows the register configuration. The MTU address space is offset from the base address. The base address of MTU is as follows.

MTU base address: H'0_1000_0000 (Overall Address Space)

Table 16.4 Register configuration (1/5)

Channel	Register Name	Abbreviation	Address	Access size	
MTU0	Timer control register	TCR	H'1300	8	
	Timer mode register 1	TMDR1	H'1301	8	
	Timer I/O control register H	TIORH	H'1302	8	
	Timer I/O control register L	TIORL	H'1303	8	
	Timer interrupt enable register	TIER	H'1304	8	
	Timer counter	TCNT	H'1306	16	
	Timer general register A	TGRA	H'1308	16	
	Timer general register B	TGRB	H'130A	16	
	Timer general register C	TGRC	H'130C	16	
	Timer general register D	TGRD	H'130E	16	
	Timer general register E	TGRE	H'1320	16	
	Timer general register F	TGRF	H'1322	16	
	Timer interrupt enable register 2	TIER2	H'1324	8	
	Timer buffer operation transfer mode register	TBTM	H'1326	8	
	Timer control register 2	TCR2	H'1328	8	
	Noise filter control register 0	NFCR0	H'1290	8	
	Noise filter control register C	NFCRC	H'1299	8	
MTU1	Timer control register	TCR	H'1380	8	
	Timer mode register 1	TMDR1	H'1381	8	
	Timer I/O control register	TIOR	H'1382	8	
	Timer interrupt enable register	TIER	H'1384	8	
	Timer status register	TSR	H'1385	8	
	Timer counter	TCNT	H'1386	16	
	Timer general register A	TGRA	H'1388	16	
	Timer general register B	TGRB	H'138A	16	
	Timer input capture control register	TICCR	H'1390	8	
	Timer mode register 3	TMDR3	H'1391	8	
	Timer control register 2	TCR2	H'1394	8	
	Timer longword counter	TCNTLW	H'13A0	32	
	Timer longword general register A	TGRALW	H'13A4	32	
	Timer longword general register B	TGRBLW	H'13A8	32	
	Noise filter control register 1	NFCR1	H'1291	8	
	MTU2	Timer control register	TCR	H'1400	8
		Timer mode register 1	TMDR1	H'1401	8
Timer I/O control register		TIOR	H'1402	8	
Timer interrupt enable register		TIER	H'1404	8	
Timer status register		TSR	H'1405	8	
Timer counter		TCNT	H'1406	16	
Timer general register A		TGRA	H'1408	16	

Table 16.4 Register configuration (2/5)

Channel	Register Name	Abbreviation	Address	Access size
MTU2	Timer general register B	TGRB	H'140A	16
	Timer control register 2	TCR2	H'140C	8
	Noise filter control register 2	NFCR2	H'1292	8
MTU3	Timer control register	TCR	H'1200	8
	Timer mode register 1	TMDR1	H'1202	8
	Timer I/O control register H	TIORH	H'1204	8
	Timer I/O control register L	TIORL	H'1205	8
	Timer interrupt enable register	TIER	H'1208	8
	Timer counter	TCNT	H'1210	16
	Timer general register A	TGRA	H'1218	16
	Timer general register B	TGRB	H'121A	16
	Timer general register C	TGRC	H'1224	16
	Timer general register D	TGRD	H'1226	16
	Timer control register 2	TCR2	H'124C	8
	Timer general register E	TGRE	H'1272	16
	Timer status register	TSR	H'122C	8
	Timer buffer operation transfer mode register	TBTM	H'1238	8
	Noise filter control register 3	NFCR3	H'1293	8
	MTU4	Timer control register	TCR	H'1201
Timer mode register 1		TMDR1	H'1203	8
Timer I/O control register H		TIORH	H'1206	8
Timer I/O control register L		TIORL	H'1207	8
Timer interrupt enable register		TIER	H'1209	8
Timer counter		TCNT	H'1212	16
Timer general register A		TGRA	H'121C	16
Timer general register B		TGRB	H'121E	16
Timer general register C		TGRC	H'1228	16
Timer general register D		TGRD	H'122A	16
Timer control register 2		TCR2	H'124D	8
Timer general register E		TGRE	H'1274	16
Timer general register F		TGRF	H'1276	16
Timer status register		TSR	H'122D	8
Timer buffer operation transfer mode register		TBTM	H'1239	8
Timer A/D converter start request control register		TADCR	H'1240	16
Timer A/D converter start request cycle set register A		TADCORA	H'1244	16
Timer A/D converter start request cycle set register B		TADCORB	H'1246	16
Timer A/D converter start request cycle set buffer register A		TADCOBRA	H'1248	16
Timer A/D converter start request cycle set buffer register B		TADCOBRB	H'124A	16
Noise filter control register 4	NFCR4	H'1294	8	
MTU5	Timer counter U	TCNTU	H'1C80	16
	Timer general register U	TGRU	H'1C82	16
	Timer control register U	TCRU	H'1C84	8
	Timer control register 2U	TCR2U	H'1C85	8
	Timer I/O control register U	TIORU	H'1C86	8
	Timer counter V	TCNTV	H'1C90	16

Table 16.4 Register configuration (3/5)

Channel	Register Name	Abbreviation	Address	Access size	
MTU5	Timer general register V	TGRV	H'1C92	16	
	Timer control register V	TCRV	H'1C94	8	
	Timer control register 2V	TCR2V	H'1C95	8	
	Timer I/O control register V	TIORV	H'1C96	8	
	Timer counter W	TCNTW	H'1CA0	16	
	Timer general register W	TGRW	H'1CA2	16	
	Timer control register W	TCRW	H'1CA4	8	
	Timer control register 2W	TCR2W	H'1CA5	8	
	Timer I/O control register W	TIORW	H'1CA6	8	
	Timer interrupt enable register	TIER	H'1CB2	8	
	Timer start register	TSTR	H'1CB4	8	
	Timer compare match clear register	TCNTCMPCLR	H'1CB6	8	
	Noise filter control register 5	NFCR5	H'1A95	8	
	MTU6	Timer control register	TCR	H'1A00	8
Timer mode register 1		TMDR1	H'1A02	8	
Timer I/O control register H		TIORH	H'1A04	8	
Timer I/O control register L		TIORL	H'1A05	8	
Timer interrupt enable register		TIER	H'1A08	8	
Timer counter		TCNT	H'1A10	16	
Timer general register A		TGRA	H'1A18	16	
Timer general register B		TGRB	H'1A1A	16	
Timer general register C		TGRC	H'1A24	16	
Timer general register D		TGRD	H'1A26	16	
Timer control register 2		TCR2	H'1A4C	8	
Timer general register E		TGRE	H'1A72	16	
Timer synchronous clear register		TSYCR	H'1A50	8	
Timer status register		TSR	H'1A2C	8	
Timer buffer operation transfer mode register		TBTM	H'1A38	8	
Noise filter control register 6		NFCR6	H'1A93	8	
MTU7		Timer control register	TCR	H'1A01	8
		Timer mode register 1	TMDR1	H'1A03	8
	Timer I/O control register H	TIORH	H'1A06	8	
	Timer I/O control register L	TIORL	H'1A07	8	
	Timer interrupt enable register	TIER	H'1A09	8	
	Timer counter	TCNT	H'1A12	16	
	Timer general register A	TGRA	H'1A1C	16	
	Timer general register B	TGRB	H'1A1E	16	
	Timer general register C	TGRC	H'1A28	16	
	Timer general register D	TGRD	H'1A2A	16	
	Timer control register 2	TCR2	H'1A4D	8	
	Timer general register E	TGRE	H'1A74	16	
	Timer general register F	TGRF	H'1A76	16	
	Timer status register	TSR	H'1A2D	8	
	Timer buffer operation transfer mode register	TBTM	H'1A39	8	
	Timer A/D converter start request control register	TADCR	H'1A40	16	

Table 16.4 Register configuration (4/5)

Channel	Register Name	Abbreviation	Address	Access size
MTU7	Timer A/D converter start request cycle set register A	TADCORA	H'1A44	16
	Timer A/D converter start request cycle set register B	TADCORB	H'1A46	16
	Timer A/D converter start request cycle set buffer register A	TADCOBRA	H'1A48	16
	Timer A/D converter start request cycle set buffer register B	TADCOBRB	H'1A4A	16
	Noise filter control register 7	NFCR7	H'1A94	8
MTU8	Timer control register	TCR	H'1600	8
	Timer mode register 1	TMDR1	H'1601	8
	Timer I/O control register H	TIORH	H'1602	8
	Timer I/O control register L	TIORL	H'1603	8
	Timer interrupt enable register	TIER	H'1604	8
	Timer control register 2	TCR2	H'1606	8
	Timer counter	TCNT	H'1608	32
	Timer general register A	TGRA	H'160C	32
	Timer general register B	TGRB	H'1610	32
	Timer general register C	TGRC	H'1614	32
	Timer general register D	TGRD	H'1618	32
	Noise filter control register 8	NFCR8	H'1298	8
MTU	Timer output master enable register A	TOERA	H'120A	8
	Timer gate control register A	TGCRA	H'120D	8
	Timer output control register 1A	TOCR1A	H'120E	8
	Timer output control register 2A	TOCR2A	H'120F	8
	Timer cycle data register A	TCDRA	H'1214	16
	Timer dead time data register A	TDDRA	H'1216	16
	Timer subcounter A	TCNTSA	H'1220	16
	Timer cycle buffer register A	TCBRA	H'1222	16
	Timer interrupt skipping set register 1A	TITCR1A	H'1230	8
	Timer interrupt skipping counter 1A	TITCNT1A	H'1231	8
	Timer buffer transfer set register A	TBTERA	H'1232	8
	Timer dead time enable register A	TDERA	H'1234	8
	Timer output level buffer register A	TOLBRA	H'1236	8
	Timer interrupt skipping mode register A	TITMRA	H'123A	8
	Timer interrupt skipping set register 2A	TITCR2A	H'123B	8
	Timer interrupt skipping counter 2A	TITCNT2A	H'123C	8
	Timer waveform control register A	TWCRA	H'1260	8
	Timer mode register 2A	TMDR2A	H'1270	8
	Timer read/write enable register A	TRWERA	H'1284	8
	Timer start register A	TSTRA	H'1280	8
	Timer synchronous register A	TSYRA	H'1281	8
	Timer output master enable register B	TOERB	H'1A0A	8
	Timer output control register 1B	TOCR1B	H'1A0E	8
	Timer output control register 2B	TOCR2B	H'1A0F	8
	Timer cycle data register B	TCDRB	H'1A14	16
	Timer dead time data register B	TDDR B	H'1A16	16
	Timer subcounter B	TCNTSB	H'1A20	16
	Timer cycle buffer register B	TCBRB	H'1A22	16

Table 16.4 Register configuration (5/5)

Channel	Register Name	Abbreviation	Address	Access size
MTU	Timer interrupt skipping set register 1B	TITCR1B	H'1A30	8
	Timer interrupt skipping counter 1B	TITCNT1B	H'1A31	8
	Timer buffer transfer set register B	TBTERB	H'1A32	8
	Timer dead time enable register B	TDERB	H'1A34	8
	Timer output level buffer register B	TOLBRB	H'1A36	8
	Timer interrupt skipping mode register B	TITMRB	H'1A3A	8
	Timer interrupt skipping set register 2B	TITCR2B	H'1A3B	8
	Timer interrupt skipping counter 2B	TITCNT2B	H'1A3C	8
	Timer waveform control register B	TWCRB	H'1A60	8
	Timer mode register 2B	TMDR2B	H'1A70	8
	Timer start register B	TSTRB	H'1A80	8
	Timer synchronous register B	TSYRB	H'1A81	8
	Timer read/write enable register B	TRWERB	H'1A84	8
	Timer counter synchronous start register	TCSYSTR	H'1282	8

16.2.1 Timer Control Register (TCR)

(1) MTU0.TCR, MTU1.TCR, MTU2.TCR, MTU3.TCR, MTU4.TCR, MTU6.TCR, MTU7.TCR, MTU8.TCR

Address(es): MTU0.TCR H'0_1000_1300, MTU1.TCR H'0_1000_1380, MTU2.TCR H'0_1000_1400,
MTU3.TCR H'0_1000_1200, MTU4.TCR H'0_1000_1201, MTU6.TCR H'0_1000_1A00,
MTU7.TCR H'0_1000_1A01, MTU8.TCR H'0_1000_1600

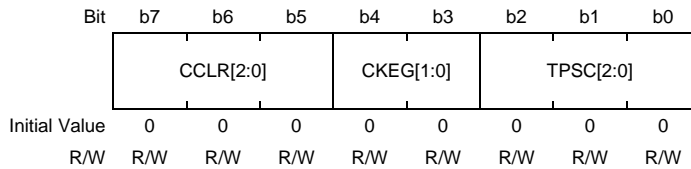

Bit	Bit Name	Initial Value	R/W	Description
b2 to b0	TPSC[2:0]	All 0	R/W	Time Prescaler Select See Table 16.7 to Table 16.10 .
b4, b3	CKEG[1:0]	All 0	R/W	Clock Edge Select b4 b3 0 0: Count at rising edge 0 1: Count at falling edge 1 x: Count at both edges
b7 to b5	CCLR[2:0]	All 0	R/W	Counter Clear Source Select See Table 16.5 and Table 16.6 .

Remarks: x: Don't care

The TCR register controls the TCNT operation for each channel in combination with the TCR2 register. The MTU has a total of 11 TCR registers, one each for MTU0 to MTU4, MTU 6, MTU7, and MTU8 and three (TCRU, TCRV, and TCRW) for MTU5. TCR values should be specified only while TCNT operation is stopped.

TPSC[2:0] Bits (Time Prescaler Select)

These bits select the TCNT count clock source. The clock source can be selected independently for each channel. See **Table 16.7** to **Table 16.10** for details.

CKEG[1:0] Bits (Clock Edge Select)

These bits select the count clock source edge, including the MTIOC1A pin. When the internal clock is counted at both edges, the count clock period is halved (e.g. $P0\phi/4$ at both edges = $P0\phi/2$ at rising edge). If phase counting mode is used on MTU1 and MTU2, the setting of these bits is ignored and the phase counting mode setting has priority. Internal clock edge selection is valid when the count clock source is $P0\phi/2$ or slower. When $P0\phi/1$ or the overflow/underflow in another channel is selected for the count clock source, a value can be written to these bits but counter operation compiles with the initial value.

CCLR[2:0] Bits (Counter Clear Source Select)

These bits select the TCNT counter clearing source. See **Table 16.5** and **Table 16.6** for details.

Table 16.5 CCLR[2:0] (MTU0, MTU3, MTU4, MTU6, MTU7, and MTU8)

Channel	Bit 7	Bit 6	Bit 5	Description
	CCLR2	CCLR1	CCLR0	
MTU0	0	0	0	TCNT clearing disabled
MTU3	0	0	1	TCNT cleared by TGRA compare match/input capture
MTU4	0	1	0	TCNT cleared by TGRB compare match/input capture
MTU6	0	1	1	TCNT cleared by counter clearing in another channel where synchronous clearing or synchronous operation is selected*1
MTU7	1	0	0	TCNT clearing disabled
MTU8	1	0	1	TCNT cleared by TGRC compare match/input capture*2
	1	1	0	TCNT cleared by TGRD compare match/input capture*2
	1	1	1	TCNT cleared by counter clearing in another channel where synchronous clearing or synchronous operation is selected*1

Note 1. Synchronous operation is selected by setting a SYNC bit in TSYRA or TSYRB to 1 except for MTU8.

Note 2. When TGRC or TGRD is used as a buffer register, TCNT is not cleared because the buffer register setting has priority and compare match/input capture does not occur.

Table 16.6 CCLR[2:0] (MTU1 and MTU2)

Channel	Bit 7	Bit 6	Bit 5	Description
	Reserved*2	CCLR1	CCLR0	
MTU1	0	0	0	TCNT clearing disabled
MTU2	0	0	1	TCNT cleared by TGRA compare match/input capture
	0	1	0	TCNT cleared by TGRB compare match/input capture
	0	1	1	TCNT cleared by counter clearing in another channel where synchronous clearing or synchronous operation is selected*1

Note 1. Synchronous operation is selected by setting a SYNC bit in TSYRA or TSYRB to 1.

Note 2. Bit 7 is reserved in MTU1 and MTU2. It is read as 0. The write value is ignored.

(2) MTU5.TCRU, MTU5.TCRV, MTU5.TCRW

Address(es): MTU5.TCRU H'0_1000_1C84, MTU5.TCRV H'0_1000_1C94, MTU5.TCRW H'0_1000_1CA4

Bit	b7	b6	b5	b4	b3	b2	b1	b0
	—	—	—	—	—	—	TPSC[1:0]	
Initial Value	0	0	0	0	0	0	0	0
R/W	R/W	R/W	R/W	R/W	R/W	R/W	R/W	R/W

Bit	Bit Name	Initial Value	R/W	Description
b1, b0	TPSC[1:0]	All 0	R/W	Time Prescaler Select See Table 16.11 .
b7 to b2	—	All 0	R/W	Reserved These bits are read as 0. The write value should be 0.

TPSC[1:0] Bits (Time Prescaler Select)

These bits select the TCNT count clock source. See **Table 16.11** for details.

16.2.2 Timer Control Register 2 (TCR2)

(1) MTU0.TCR2, MTU3.TCR2, MTU4.TCR2, MTU6.TCR2, MTU7.TCR2, MTU8.TCR2

Address(es): MTU0.TCR2 H'0_1000_1328, MTU3.TCR2 H'0_1000_124C, MTU4.TCR2 H'0_1000_124D,
MTU6.TCR2 H'0_1000_1A4C, MTU7.TCR2 H'0_1000_1A4D, MTU8.TCR2 H'0_1000_1606

Bit	b7	b6	b5	b4	b3	b2	b1	b0
	—	—	—	—	—	TPSC2[2:0]		
Initial Value	0	0	0	0	0	0	0	0
	R/W	R/W	R/W	R/W	R/W	R/W	R/W	R/W

(2) MTU1.TCR2, MTU2.TCR2

Address(es): MTU1.TCR2 H'0_1000_1394, MTU2.TCR2 H'0_1000_140C

Bit	b7	b6	b5	b4	b3	b2	b1	b0
	—	—	—	PCB[1:0]		TPSC2[2:0]		
Initial Value	0	0	0	0	0	0	0	0
	R/W	R/W	R/W	R/W	R/W	R/W	R/W	R/W

Bit	Bit Name	Initial Value	R/W	Description
b2 to b0	TPSC2[2:0]	All 0	R/W	Time Prescaler Select See Table 16.7 to Table 16.10 .
b4, b3	PCB[1:0]	All 0	R/W	Phase Counting Mode Function Expansion Control Functional Expansion Control for Phase Counting Modes 2, 3, and 5
b7 to b5	—	All 0	R/W	Reserved These bits are read as 0. The write value should be 0.

The TCR2 register controls the TCNT operation for each channel in combination with the TCR register. The MTU has a total of 11 TCR2 registers, one each for MTU0 to MTU4, MTU 6, MTU7, and MTU8 and three (TCR2U, TCR2V, and TCR2W) for MTU5. TCR2 values should be specified only while TCNT operation is stopped.

TPSC2[2:0] Bits (Time Prescaler Select)

These bits select the TCNT count clock source. The clock source can be selected independently for each channel. See **Table 16.7** to **Table 16.10** for details.

PCB[1:0] Bits (Phase Counting Mode Function Expansion Control)

These bits control extended functions for phase counting mode 2, 3, and 5 in MTU1 and MTU2. See **Section 16.3.6, Phase Counting Mode**.

(3) MTU5.TCR2U, MTU5.TCR2V, MTU5.TCR2W**Address(es):** MTU5.TCR2U H'0_1000_1C85, MTU5.TCR2V H'0_1000_1C95, MTU5.TCR2W H'0_1000_1CA5

Bit	b7	b6	b5	b4	b3	b2	b1	b0
	—	—	—	CKEG[1:0]		TPSC2[2:0]		
Initial Value	0	0	0	0	0	0	0	0
R/W	R/W	R/W	R/W	R/W	R/W	R/W	R/W	R/W

Bit	Bit Name	Initial Value	R/W	Description
b2 to b0	TPSC2[2:0]	All 0	R/W	Time Prescaler Select See Table 16.11 .
b4, b3	CKEG[1:0]	All 0	R/W	Clock Edge Select b4 b3 0 0: Counts at the rising edge. 0 1: Counts at the falling edge. 1 x: Counts at both edges.
b7 to b5	—	All 0	R/W	Reserved These bits are read as 0. The write value should be 0.

Remarks: x: Don't care**TPSC2[2:0] Bits (Time Prescaler Select)**These bits select the TCNT count clock source. See **Table 16.11** for details.**CKEG[1:0] Bits (Clock Edge Select)**

These bits select the edge of the count clock source signal output from the MTIOC1A pin.

Table 16.7 TPSC[2:0], TPCR[2:0] (MTU0)

Channel	TPSC[2:0]			TPCR[2:0]			Description
	Bit 2	Bit 1	Bit 0	Bit 2	Bit 1	Bit 0	
	TPSC22	TPSC21	TPSC20	TPSC2	TPSC1	TPSC0	
MTU0	0	0	0	0	0	0	Internal clock: counts on P0φ/1
	0	0	0	0	0	1	Internal clock: counts on P0φ/4
	0	0	0	0	1	0	Internal clock: counts on P0φ/16
	0	0	0	0	1	1	Internal clock: counts on P0φ/64
	0	0	0	1	0	0	External clock: counts on MTCLKA pin input
	0	0	0	1	0	1	External clock: counts on MTCLKB pin input
	0	0	0	1	1	0	External clock: counts on MTCLKC pin input
	0	0	0	1	1	1	External clock: counts on MTCLKD pin input
	0	0	1	x	x	x	Internal clock: counts on P0φ/2
	0	1	0	x	x	x	Internal clock: counts on P0φ/8
	0	1	1	x	x	x	Internal clock: counts on P0φ/32
	1	0	0	x	x	x	Internal clock: counts on P0φ/256
	1	0	1	x	x	x	Internal clock: counts on P0φ/1024
	1	1	0	x	x	x	Setting prohibited
	1	1	1	x	x	x	External clock: counts on MTIOC1A pin input

Remarks: x: Don't care

Table 16.8 TPSC[2:0], TPCR[2:0] (MTU1)

Channel	TPSC[2:0]			TPCR[2:0]			Description
	Bit 2	Bit 1	Bit 0	Bit 2	Bit 1	Bit 0	
	TPSC22	TPSC21	TPSC20	TPSC2	TPSC1	TPSC0	
MTU1	0	0	0	0	0	0	Internal clock: counts on P0φ/1
	0	0	0	0	0	1	Internal clock: counts on P0φ/4
	0	0	0	0	1	0	Internal clock: counts on P0φ/16
	0	0	0	0	1	1	Internal clock: counts on P0φ/64
	0	0	0	1	0	0	External clock: counts on MTCLKA pin input
	0	0	0	1	0	1	External clock: counts on MTCLKB pin input
	0	0	0	1	1	0	Internal clock: counts on P0φ/256
	0	0	0	1	1	1	Overflow/underflow of MTU2.TCNT
	0	0	1	x	x	x	Internal clock: counts on P0φ/2
	0	1	0	x	x	x	Internal clock: counts on P0φ/8
	0	1	1	x	x	x	Internal clock: counts on P0φ/32
	1	0	0	x	x	x	Internal clock: counts on P0φ/1024
	1	0	1	x	x	x	Setting prohibited
	1	1	0	x	x	x	Setting prohibited
	1	1	1	x	x	x	Setting prohibited

Note: This setting has no effect when MTU1 is in phase counting mode.

Remarks: x: Don't care

Table 16.9 TPSC[2:0], TCR2[2:0] (MTU2)

Channel	TCR2[2:0]			TCR[2:0]			Description
	Bit 2	Bit 1	Bit 0	Bit 2	Bit 1	Bit 0	
	TPSC22	TPSC21	TPSC20	TPSC2	TPSC1	TPSC0	
MTU2	0	0	0	0	0	0	Internal clock: counts on P0φ/1
	0	0	0	0	0	1	Internal clock: counts on P0φ/4
	0	0	0	0	1	0	Internal clock: counts on P0φ/16
	0	0	0	0	1	1	Internal clock: counts on P0φ/64
	0	0	0	1	0	0	External clock: counts on MTCLKA pin input
	0	0	0	1	0	1	External clock: counts on MTCLKB pin input
	0	0	0	1	1	0	External clock: counts on MTCLKC pin input
	0	0	0	1	1	1	Internal clock: counts on P0φ/1024
	0	0	1	x	x	x	Internal clock: counts on P0φ/2
	0	1	0	x	x	x	Internal clock: counts on P0φ/8
	0	1	1	x	x	x	Internal clock: counts on P0φ/32
	1	0	0	x	x	x	Internal clock: counts on P0φ/256
	1	0	1	x	x	x	Setting prohibited
	1	1	0	x	x	x	Setting prohibited
1	1	1	x	x	x	Setting prohibited	

Note: This setting has no effect when the MTU2 is in phase counting mode.

Remarks: x: Don't care

Table 16.10 TPSC[2:0], TCR2[2:0] (MTU3, MTU4, MTU6, MTU7, and MTU8)

Channel	TCR2[2:0]			TCR[2:0]			Description
	Bit 2	Bit 1	Bit 0	Bit 2	Bit 1	Bit 0	
	TPSC22	TPSC21	TPSC20	TPSC2	TPSC1	TPSC0	
MTU3	0	0	0	0	0	0	Internal clock: counts on P0φ/1
MTU4	0	0	0	0	0	1	Internal clock: counts on P0φ/4
MTU6	0	0	0	0	1	0	Internal clock: counts on P0φ/16
MTU7	0	0	0	0	1	1	Internal clock: counts on P0φ/64
MTU8	0	0	0	1	0	0	Internal clock: counts on P0φ/256
	0	0	0	1	0	1	Internal clock: counts on P0φ/1024
	0	0	0	1	1	0	External clock: counts on MTCLKA pin input
	0	0	0	1	1	1	External clock: counts on MTCLKB pin input
	0	0	1	x	x	x	Internal clock: counts on P0φ/2
	0	1	0	x	x	x	Internal clock: counts on P0φ/8
	0	1	1	x	x	x	Internal clock: counts on P0φ/32
	1	0	0	x	x	x	Setting prohibited
	1	0	1	x	x	x	Setting prohibited
	1	1	0	x	x	x	Setting prohibited
	1	1	1	x	x	x	Setting prohibited

Remarks: x: Don't care

Table 16.11 TPSC[1:0], TPSC2[2:0] (MTU5)

Channel	TPSC2[2:0]			TPSC1[1:0]		Description
	Bit 2	Bit 1	Bit 0	Bit 1	Bit 0	
	TPSC22	TPSC21	TPSC20	TPSC11	TPSC10	
MTU5	0	0	0	0	0	Internal clock: counts on P0 ϕ /1
	0	0	0	0	1	Internal clock: counts on P0 ϕ /4
	0	0	0	1	0	Internal clock: counts on P0 ϕ /16
	0	0	0	1	1	Internal clock: counts on P0 ϕ /64
	0	0	1	x	x	Internal clock: counts on P0 ϕ /2
	0	1	0	x	x	Internal clock: counts on P0 ϕ /8
	0	1	1	x	x	Internal clock: counts on P0 ϕ /32
	1	0	0	x	x	Internal clock: counts on P0 ϕ /256
	1	0	1	x	x	Internal clock: counts on P0 ϕ /1024
	1	1	0	x	x	Setting prohibited
1	1	1	x	x	Internal clock: counts on MTIOC1A pin input	

Remarks: x: Don't care

16.2.3 Timer Mode Register 1 (TMDR1)

(1) MTU0.TMDR1

Address(es): MTU0.TMDR1 H'0_1000_1301

Bit	b7	b6	b5	b4	b3	b2	b1	b0
	—	BFE	BFB	BFA	MD[3:0]			
Initial Value	0	0	0	0	0	0	0	0
	R/W	R/W	R/W	R/W	R/W	R/W	R/W	R/W

(2) MTU1.TMDR1, MTU2.TMDR1

Address(es): MTU1.TMDR1 H'0_1000_1381, MTU2.TMDR1 H'0_1000_1401

Bit	b7	b6	b5	b4	b3	b2	b1	b0
	—	—	—	—	MD[3:0]			
Initial Value	0	0	0	0	0	0	0	0
	R/W	R/W	R/W	R/W	R/W	R/W	R/W	R/W

(3) MTU3.TMDR1, MTU4.TMDR1, MTU6.TMDR1, MTU7.TMDR1, MTU8.TMDR1

Address(es): MTU3.TMDR1 H'0_1000_1202, MTU4.TMDR1 H'0_1000_1203, MTU6.TMDR1 H'0_1000_1A02, MTU7.TMDR1 H'0_1000_1A03, MTU8.TMDR1 H'0_1000_1601

Bit	b7	b6	b5	b4	b3	b2	b1	b0
	—	—	BFB	BFA	MD[3:0]			
Initial Value	0	0	0	0	0	0	0	0
	R/W	R/W	R/W	R/W	R/W	R/W	R/W	R/W

Bit	Bit Name	Initial Value	R/W	Description
b3 to b0	MD[3:0]	All 0	R/W	Mode Select These bits specify the timer operating mode. See Table 16.12 for details.
b4	BFA	0	R/W	Buffer Operation A 0: TGRA and TGRC operate normally 1: TGRA and TGRC used together for buffer operation
b5	BFB	0	R/W	Buffer Operation B 0: TGRB and TGRD operate normally 1: TGRB and TGRD used together for buffer operation
b6	BFE	0	R/W	Buffer Operation E 0: MTU0.TGRE and MTU0.TGRF operate normally 1: MTU0.TGRE and MTU0.TGRF used together for buffer operation
b7	—	0	R/W	Reserved This bit is read as 0. The write value should be 0.

The TMDR1 register specifies the operating mode of each channel. The MTU has a total of eight TMDR1 registers, one each for MTU0 to MTU4, MTU 6, MTU7, and MTU8. TMDR1 register values should be specified only while TCNT operation is stopped.

Table 16.12 Operating Mode Setting by MD[3:0] Bits (MTU0 to MTU4, MTU6 to MTU8)

Bit 3	Bit 2	Bit 1	Bit 0		MTU0	MTU1	MTU2	MTU1 & MTU2 (LWA = 1)	MTU3	MTU4	MTU6	MTU7	MTU8
MD3	MD2	MD1	MD0	Description									
0	0	0	0	Normal mode	✓	✓	✓		✓	✓	✓	✓	✓
0	0	0	1	Setting prohibited									
0	0	1	0	PWM mode 1	✓	✓	✓		✓	✓	✓	✓	
0	0	1	1	PWM mode 2	✓	✓	✓						
0	1	0	0	Phase counting mode 1		✓	✓	✓					
0	1	0	1	Phase counting mode 2		✓	✓	✓					
0	1	1	0	Phase counting mode 3		✓	✓	✓					
0	1	1	1	Phase counting mode 4		✓	✓	✓					
1	0	0	0	Reset-synchronized PWM mode* ¹					✓		✓		
1	0	0	1	Phase counting mode 5		✓	✓	✓					
1	0	1	x	Setting prohibited									
1	1	0	0	Setting prohibited									
1	1	0	1	Complementary PWM mode 1 (transfer at crest)* ¹					✓		✓		
1	1	1	0	Complementary PWM mode 2 (transfer at trough)* ¹					✓		✓		
1	1	1	1	Complementary PWM mode 3 (transfer at crest and trough)* ¹					✓		✓		

Note: Only set the corresponding operating mode listed above for each channel.

Remarks: x: Don't care

Note 1. Reset-synchronized PWM mode and complementary PWM mode can only be set for MTU3 and MTU6. When MTU3 or MTU6 is set to reset-synchronized PWM mode or complementary PWM mode, the MTU4 or MTU7 settings become ineffective and automatically conform to the MTU3 or MTU6 setting, respectively. MTU4 and MTU7 should be set to the initial values (normal mode).

BFA Bit (Buffer Operation A)

This bit specifies whether to operate TGRA in the normal way or to use TGRA and TGRC together for buffer operation. When TGRC is used as a buffer register, TGRC input capture/output compare does not take place in modes other than complementary PWM mode, but compare match with TGRC occurs in complementary PWM mode.

If a compare match occurs on MTU4 in the Tb interval in complementary PWM mode, the TGIEC bit in timer interrupt enable register (MTU4.TIER) should be set to 0.

In reset-synchronized PWM mode or complementary PWM mode, buffer operation in MTU3 and MTU4 (or MTU6 and MTU7) depends on the settings in the BFA bit of MTU3.TMDR1 (MTU6.TMDR1). The BFA bit of MTU4.TMDR1 (MTU7.TMDR1) should be set to 0.

In MTU1 and MTU2, which have no TGRC, this bit is reserved. It is read as 0. The write value should be 0. See **Figure 16.50** for an illustration of the Tb interval in complementary PWM mode.

BFB Bit (Buffer Operation B)

This bit specifies whether to operate TGRB in the normal way or to use TGRB and TGRD together for buffer operation. When TGRD is used as a buffer register, TGRD input capture/output compare does not take place in modes other than complementary PWM mode, but compare match with TGRD occurs in complementary PWM mode.

If a compare match occurs on MTU4 in the Tb interval in complementary PWM mode, the TGIED bit in timer interrupt enable register (MTU4.TIER) should be set to 0.

In reset-synchronized PWM mode or complementary PWM mode, buffer operation in MTU3 and MTU4 (or MTU6 and MTU7) depends on the settings in the BFB bit of MTU3.TMDR1 (MTU6.TMDR1). The BFB bit of MTU4.TMDR1 (MTU7.TMDR1) should be set to 0.

In MTU1 and MTU2, which have no TGRD, this bit is reserved. It is read as 0. The write value should be 0. See **Figure 16.50** for an illustration of the Tb interval in complementary PWM mode.

BFE Bit (Buffer Operation E)

This bit specifies whether to operate MTU0.TGRE and MTU0.TGRF in the normal way or to use them together for buffer operation. Compare match with TGRF occurs even when TGRF is used as a buffer register.

In MTU0 to MTU4, MTU6, MTU7, and MTU8, this bit is reserved. It is read as 0. The write value should be 0.

16.2.4 Timer Mode Registers 2 (TMDR2A and TMDR2B)

Address(es): MTU.TMDR2A H'0_1000_1270, MTU.TMDR2B H'0_1000_1A70

Bit	b7	b6	b5	b4	b3	b2	b1	b0
	—	—	—	—	—	—	—	DRS
Initial Value	0	0	0	0	0	0	0	0
R/W	R/W	R/W	R/W	R/W	R/W	R/W	R/W	R/W

Bit	Bit Name	Initial Value	R/W	Description
b0	DRS	0	R/W	Double Buffer Select 0: Double buffer function is disabled 1: Double buffer function is enabled
b7 to b1	—	All 0	R/W	Reserved These bits are read as 0. The write value should be 0.

TMDR2A and TMDR2B specify the double buffer function in complementary PWM mode 3 (transfer at the crest and trough of the counter value). The MTU has two TMDR2 registers, one each for MTU3 (TMDR2A) and MTU6 (TMDR2B). TMDR2A and TMDR2B values should be specified only while TCNT operation is stopped.

DRS Bit (Double Buffer Select)

This bit enables or disables the double buffer function in complementary PWM mode.

16.2.5 Timer Mode Register 3 (TMDR3)

Address(es): MTU1.TMDR3 H'0_1000_1391

Bit	b7	b6	b5	b4	b3	b2	b1	b0
	—	—	—	—	—	—	PHCKSEL	LWA
Initial Value	0	0	0	0	0	0	1	0
R/W	R/W	R/W	R/W	R/W	R/W	R/W	R/W	R/W

Bit	Bit Name	Initial Value	R/W	Description
b0	LWA	0	R/W	MTU1/MTU2 Combination Longword Access Control 0: 16-bit access is enabled. 1: 32-bit access is enabled.
b1	PHCKSEL	1	R/W	External Input Phase Clock Select Selects the external clock pin for phase counting mode. 0: MTCLKA and MTCLKB are selected for the external phase clock. 1: MTCLKC and MTCLKD are selected for the external phase clock.
b7 to b2	—	All 0	R/W	Reserved These bits are read as 0. The write value should be 0.

The TMDR3 register controls longword access to a 32-bit register or counter in a combination of MTU1 and MTU2. There is only one TMDR3 register in MTU1. The counter (TCNTLW), general register A (TGRALW), and general register B (TGRBLW) of MTU1 and MTU2 are accessed in the combinations listed in **Table 16.13**.

LWA Bit (MTU1/MTU2 Combination Longword Access Control)

This bit selects a 32-bit access in a combination of MTU1 and MTU2.

When the LWA bit is set to 0, MTU1 and MTU2 operate independently as 16-bit timers and the TCNTLW, TGRALW, and TGRBLW registers cannot be accessed.

When the LWA bit is set to 1, MTU1 and MTU2 are cascaded and operate as a 32-bit timer, which is controlled through the TCR, TCR2, TIOR, and TMDR1 registers in MTU1. The TCR, TCR2, TIOR, and TMDR1 register settings in MTU2 are ignored. The 16-bit registers (TCNT, TGRA, and TGRB) in MTU1 and MTU2 cannot be accessed. MTU2 input capture and compare match are disabled.

Note that MTU1 and MTU2 can be cascaded by setting the LWA bit to 1 only in phase-counting mode. Cascade connection cannot be used in normal, PWM1, or PWM2 mode. When setting the LWA bit to 1, be sure to select phase-counting mode.

In addition, initialize the TCNT, TGRA, and TGRB registers in MTU1 and MTU2 before setting the LWA bit to 1.

PHCKSEL Bit (External Input Phase Clock Select)

When the MTU1 and MTU2 registers are combined for 32-bit phase counting mode or MTU2 phase counting mode, this bit selects either the A- or B-phase signal from the external clock. See **Table 16.66, Clock Input Pins in Phase Counting Mode** for details.

Table 16.13 Setting and Combination of the TMDR3 Register

Register	TMDR3.LWA = 0		TMDR3.LWA = 1	
	Symbol	Access mode	Symbol	Access mode
Counter in MTU1*1	MTU1.TCNT	Word	MTU1.TCNT_1_LW	Longword
Counter in MTU2	MTU2.TCNT	Word		
General register A in MTU1	MTU1.TGRA	Word	MTU1.TGRA_1_LW	Longword
General register A in MTU2	MTU2.TGRA	Word		
General register B in MTU1	MTU1.TGRB	Word	MTU1.TGRB_1_LW	Longword
General register B in MTU2	MTU2.TGRB	Word		

Note 1. When the LWA bit is set to 1, setting the count clock for MTU1 as MTU2.TCNT overflow/underflow is not required.

16.2.6 Timer I/O Control Register (TIOR)

(1) MTU0.TIORH, MTU1.TIOR, MTU2.TIOR, MTU3.TIORH, MTU4.TIORH, MTU6.TIORH, MTU7.TIORH, MTU8.TIORH

Address(es): MTU0.TIORH H'0_1000_1302, MTU1.TIOR H'0_1000_1382, MTU2.TIOR H'0_1000_1402, MTU3.TIORH H'0_1000_1204, MTU4.TIORH H'0_1000_1206, MTU6.TIORH H'0_1000_1A04, MTU7.TIORH H'0_1000_1A06, MTU8.TIORH H'0_1000_1602

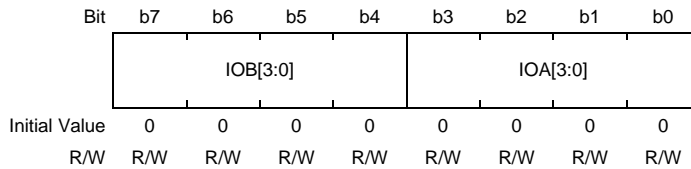

Bit	Bit Name	Initial Value	R/W	Description
b3 to b0	IOA[3:0]	All 0	R/W	I/O Control A* ¹ See the following tables. MTU0.TIORH: Table 16.28 MTU1.TIOR: Table 16.30 MTU2.TIOR: Table 16.31 MTU3.TIORH: Table 16.32 MTU4.TIORH: Table 16.34 MTU6.TIORH: Table 16.36 MTU7.TIORH: Table 16.38 MTU8.TIORH: Table 16.40
b7 to b4	IOB[3:0]	All 0	R/W	I/O Control B* ¹ See the following tables. MTU0.TIORH: Table 16.14 MTU1.TIOR: Table 16.16 MTU2.TIOR: Table 16.17 MTU3.TIORH: Table 16.18 MTU4.TIORH: Table 16.20 MTU6.TIORH: Table 16.22 MTU7.TIORH: Table 16.24 MTU8.TIORH: Table 16.26

Note 1. When the value of IO[n:3:0] (n = A, B) is changed to the output-prohibited state (0000b or 0100b) during low, high, or toggle output at compare match, this register is in Hi-Z.

(2) MTU0.TIORL, MTU3.TIORL, MTU4.TIORL, MTU6.TIORL, MTU7.TIORL, MTU8.TIORL

Address(es): MTU0.TIORL H'0_1000_1303, MTU3.TIORL H'0_1000_1205, MTU4.TIORL H'0_1000_1207,
MTU6.TIORL H'0_1000_1A05, MTU7.TIORL H'0_1000_1A07, MTU8.TIORL H'0_1000_1603

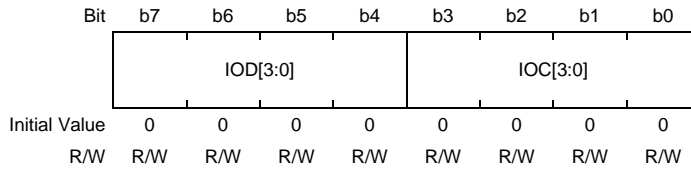

Bit	Bit Name	Initial Value	R/W	Description
b3 to b0	IOC[3:0]	All 0	R/W	I/O Control C*1 See the following tables. MTU0.TIORL: Table 16.29 MTU3.TIORL: Table 16.33 MTU4.TIORL: Table 16.35 MTU6.TIORL: Table 16.37 MTU7.TIORL: Table 16.39 MTU8.TIORL: Table 16.41
b7 to b4	IOD[3:0]	All 0	R/W	I/O Control D*1 See the following tables. MTU0.TIORL: Table 16.15 MTU3.TIORL: Table 16.19 MTU4.TIORL: Table 16.21 MTU6.TIORL: Table 16.23 MTU7.TIORL: Table 16.25 MTU8.TIORL: Table 16.27

Note 1. When the value of IOn[3:0] (n = C, D) is changed to the output-prohibited state (0000b or 0100b) during low, high, or toggle output at compare match, this register is in Hi-Z.

(3) MTU5.TIORU, MTU5.TIORV, MTU5.TIORW

Address(es): MTU5.TIORU H'0_1000_1C86, MTU5.TIORV H'0_1000_1C96, MTU5.TIORW H'0_1000_1CA6

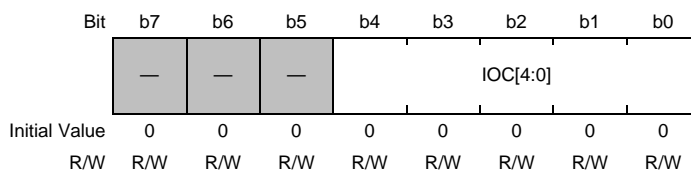

Bit	Bit Name	Initial Value	R/W	Description
b4 to b0	IOC[4:0]	All 0	R/W	I/O Control C See the following table. MTU5.TIORU, MTU5.TIORV, MTU5.TIORW: Table 16.42
b7 to b5	—	All 0	R/W	Reserved These bits are read as 0. The write value should be 0.

The TIOR register controls the TGR register. The MTU has a total of 17 TIOR registers, two each for MTU0, MTU3, MTU4, MTU6, MTU7, and MTU8, one each for MTU1 and MTU2, and three (MTU5.TIORU/TIORV/TIORW) for MTU5. The TIOR register should be set when the TMDR register setting is normal mode, PWM mode, or phase counting mode.

Note that TIOR is affected by the TMDR1 setting.

The initial output specified by TIOR is valid when the counter is stopped (the CSTn bits in TSTRA and TSTRB are cleared to 0). Note also that, in PWM mode 2, the output at the point at which the counter is cleared to 0 is specified. When TGRC or TGRD is designated for buffer operation, this setting is invalid and the register operates as a buffer register.

Table 16.14 TIORH (MTU0)

Bit 7	Bit 6	Bit 5	Bit 4	Description	
IOB3	IOB2	IOB1	IOB0	MTU0.TGRB Function	MTIOC0B Pin Function
0	0	0	0	Output compare register	Output prohibited
0	0	0	1		Initial output is low. Low output at compare match.
0	0	1	0		Initial output is low. High output at compare match.
0	0	1	1		Initial output is low. Toggle output at compare match.
0	1	0	0		Output prohibited
0	1	0	1		Initial output is high. Low output at compare match.
0	1	1	0		Initial output is high. High output at compare match.
0	1	1	1		Initial output is high. Toggle output at compare match.
1	0	0	0	Input capture register	Input capture at rising edge.
1	0	0	1		Input capture at falling edge.
1	0	1	x		Input capture at both edges.
1	1	x	x		Capture input source is the clock source for counting in MTU1. Input capture on counting up or down by TCNT (LWA = 0) or TCNTLW (LWA = 1) in MTU1*1

Remarks: Don't care

Note 1. Input capture will not be generated in MTU0 if P0φ/1 is selected as the count clock for MTU1. Select a clock other than P0φ/1.

Table 16.15 TIORL (MTU0)

Bit 7	Bit 6	Bit 5	Bit 4	Description	
IOD3	IOD2	IOD1	IOD0	MTU0.TGRD Function	MTIOC0D Pin Function
0	0	0	0	Output compare register*1	Output prohibited
0	0	0	1		Initial output is low. Low output at compare match.
0	0	1	0		Initial output is low. High output at compare match.
0	0	1	1		Initial output is low. Toggle output at compare match.
0	1	0	0		Output prohibited
0	1	0	1		Initial output is high. Low output at compare match.
0	1	1	0		Initial output is high. High output at compare match.
0	1	1	1		Initial output is high. Toggle output at compare match.
1	0	0	0	Input capture register*1	Input capture at rising edge.
1	0	0	1		Input capture at falling edge.
1	0	1	x		Input capture at both edges.
1	1	x	x		Capture input source is the clock source for counting in MTU1. Input capture on counting up or down by TCNT (LWA = 0) or TCNTLW (LWA = 1) in MTU1*2

Remarks: Don't care

Note 1. When the MTU0.TMDR1.BFB is set to 1 and MTU0.TGRD is used as a buffer register, this setting is invalid and input capture/ output compare is not generated.

Note 2. Input capture will not be generated in MTU0 if P0φ/1 is selected as the count clock for MTU1. Select a clock other than P0φ/1.

Table 16.16 TIOR (MTU1)

Bit 7	Bit 6	Bit 5	Bit 4	Description	
IOB3	IOB2	IOB1	IOB0	MTU1.TGRB/TGRBLW Function	MTIOC1B Pin Function
0	0	0	0	Output compare register	Output prohibited
0	0	0	1		Initial output is low. Low output at compare match.
0	0	1	0		Initial output is low. High output at compare match.
0	0	1	1		Initial output is low. Toggle output at compare match.
0	1	0	0		Output prohibited
0	1	0	1		Initial output is high. Low output at compare match.
0	1	1	0		Initial output is high. High output at compare match.
0	1	1	1		Initial output is high. Toggle output at compare match.
1	0	0	0	Input capture register	Input capture at rising edge.
1	0	0	1		Input capture at falling edge.
1	0	1	x		Input capture at both edges.
1	1	0	0		Input capture at occurrence of compare match or input capture in the MTU0.TGRC register
1	1	1	x		Input capture at occurrence of compare match in the MTU8.TGRC register

Remarks: x: Don't care

Table 16.17 TIOR (MTU2)

Bit 7	Bit 6	Bit 5	Bit 4	Description	
IOB3	IOB2	IOB1	IOB0	MTU2.TGRB Function	MTIOC2B Pin Function
0	0	0	0	Output compare register	Output prohibited
0	0	0	1		Initial output is low. Low output at compare match.
0	0	1	0		Initial output is low. High output at compare match.
0	0	1	1		Initial output is low. Toggle output at compare match.
0	1	0	0		Output prohibited
0	1	0	1		Initial output is high. Low output at compare match.
0	1	1	0		Initial output is high. High output at compare match.
0	1	1	1		Initial output is high. Toggle output at compare match.
1	x	0	0	Input capture register	Input capture at rising edge.
1	x	0	1		Input capture at falling edge.
1	x	1	x		Input capture at both edges.

Remarks: x: Don't care

Table 16.18 TIORH (MTU3)

Bit 7	Bit 6	Bit 5	Bit 4	Description	
IOB3	IOB2	IOB1	IOB0	MTU3.TGRB Function	MTIOC3B Pin Function
0	0	0	0	Output compare register	Output prohibited
0	0	0	1		Initial output is low. Low output at compare match.
0	0	1	0		Initial output is low. High output at compare match.
0	0	1	1		Initial output is low. Toggle output at compare match.
0	1	0	0		Output prohibited
0	1	0	1		Initial output is high. Low output at compare match.
0	1	1	0		Initial output is high. High output at compare match.
0	1	1	1		Initial output is high. Toggle output at compare match.
1	x	0	0	Input capture register	Input capture at rising edge.
1	x	0	1		Input capture at falling edge.
1	x	1	x		Input capture at both edges.

Remarks: x: Don't care

Table 16.19 TIORL (MTU3)

Bit 7	Bit 6	Bit 5	Bit 4	Description	
IOD3	IOD2	IOD1	IOD0	MTU3.TGRD Function	MTIOC3D Pin Function
0	0	0	0	Output compare register*1	Output prohibited
0	0	0	1		Initial output is low. Low output at compare match.
0	0	1	0		Initial output is low. High output at compare match.
0	0	1	1		Initial output is low. Toggle output at compare match.
0	1	0	0		Output prohibited
0	1	0	1		Initial output is high. Low output at compare match.
0	1	1	0		Initial output is high. High output at compare match.
0	1	1	1		Initial output is high. Toggle output at compare match.
1	x	0	0	Input capture register*1	Input capture at rising edge.
1	x	0	1		Input capture at falling edge.
1	x	1	x		Input capture at both edges.

Remarks: x: Don't care

Note 1. When the BFB bit in MTU3.TMDR1 is set to 1 and MTU3.TGRD is used as a buffer register, this setting is invalid and input capture/output compare is not generated.

Table 16.20 TIORH (MTU4)

Bit 7	Bit 6	Bit 5	Bit 4	Description	
IOB3	IOB2	IOB1	IOB0	MTU4.TGRB Function	MTIOC4B Pin Function
0	0	0	0	Output compare register	Output prohibited
0	0	0	1		Initial output is low. Low output at compare match.
0	0	1	0		Initial output is low. High output at compare match.
0	0	1	1		Initial output is low. Toggle output at compare match.
0	1	0	0		Output prohibited
0	1	0	1		Initial output is high. Low output at compare match.
0	1	1	0		Initial output is high. High output at compare match.
0	1	1	1		Initial output is high. Toggle output at compare match.
1	x	0	0	Input capture register	Input capture at rising edge.
1	x	0	1		Input capture at falling edge.
1	x	1	x		Input capture at both edges.

Remarks: x: Don't care

Table 16.21 TIORL (MTU4)

Bit 7	Bit 6	Bit 5	Bit 4	Description	
IOD3	IOD2	IOD1	IOD0	MTU4.TGRD Function	MTIOC4D Pin Function
0	0	0	0	Output compare register*1	Output prohibited
0	0	0	1		Initial output is low. Low output at compare match.
0	0	1	0		Initial output is low. High output at compare match.
0	0	1	1		Initial output is low. Toggle output at compare match.
0	1	0	0		Output prohibited
0	1	0	1		Initial output is high. Low output at compare match.
0	1	1	0		Initial output is high. High output at compare match.
0	1	1	1		Initial output is high. Toggle output at compare match.
1	x	0	0	Input capture register*1	Input capture at rising edge.
1	x	0	1		Input capture at falling edge.
1	x	1	x		Input capture at both edges.

Remarks: x: Don't care

Note 1. When the BFB bit in MTU4.TMDR1 is set to 1 and MTU4.TGRD is used as a buffer register, this setting is invalid and input capture/output compare is not generated.

Table 16.22 TIORH (MTU6)

Bit 7	Bit 6	Bit 5	Bit 4	Description	
IOB3	IOB2	IOB1	IOB0	MTU6.TGRB Function	MTIOC6B Pin Function
0	0	0	0	Output compare register	Output prohibited
0	0	0	1		Initial output is low. Low output at compare match.
0	0	1	0		Initial output is low. High output at compare match.
0	0	1	1		Initial output is low. Toggle output at compare match.
0	1	0	0		Output prohibited
0	1	0	1		Initial output is high. Low output at compare match.
0	1	1	0		Initial output is high. High output at compare match.
0	1	1	1		Initial output is high. Toggle output at compare match.
1	x	0	0	Input capture register	Input capture at rising edge.
1	x	0	1		Input capture at falling edge.
1	x	1	x		Input capture at both edges.

Remarks: x: Don't care

Table 16.23 TIORL (MTU6)

Bit 7	Bit 6	Bit 5	Bit 4	Description	
IOD3	IOD2	IOD1	IOD0	MTU6.TGRD Function	MTIOC6D Pin Function
0	0	0	0	Output compare register*1	Output prohibited
0	0	0	1		Initial output is low. Low output at compare match.
0	0	1	0		Initial output is low. High output at compare match.
0	0	1	1		Initial output is low. Toggle output at compare match.
0	1	0	0		Output prohibited
0	1	0	1		Initial output is high. Low output at compare match.
0	1	1	0		Initial output is high. High output at compare match.
0	1	1	1		Initial output is high. Toggle output at compare match.
1	x	0	0	Input capture register*1	Input capture at rising edge.
1	x	0	1		Input capture at falling edge.
1	x	1	x		Input capture at both edges.

Remarks: x: Don't care

Note 1. When the BFB bit in MTU6.TMDR1 is set to 1 and MTU6.TGRD register is used as a buffer register, this setting is invalid and input capture/output compare is not generated.

Table 16.24 TIORH (MTU7)

Bit 7	Bit 6	Bit 5	Bit 4	Description	
IOB3	IOB2	IOB1	IOB0	MTU7.TGRB Function	MTIOC7B Pin Function
0	0	0	0	Output compare register	Output prohibited
0	0	0	1		Initial output is low. Low output at compare match.
0	0	1	0		Initial output is low. High output at compare match.
0	0	1	1		Initial output is low. Toggle output at compare match.
0	1	0	0		Output prohibited
0	1	0	1		Initial output is high. Low output at compare match.
0	1	1	0		Initial output is high. High output at compare match.
0	1	1	1		Initial output is high. Toggle output at compare match.
1	x	0	0	Input capture register	Input capture at rising edge.
1	x	0	1		Input capture at falling edge.
1	x	1	x		Input capture at both edges.

Remarks: x: Don't care

Table 16.25 TIORL (MTU7)

Bit 7	Bit 6	Bit 5	Bit 4	Description	
IOD3	IOD2	IOD1	IOD0	MTU7.TGRD Function	MTIOC7D Pin Function
0	0	0	0	Output compare register*1	Output prohibited
0	0	0	1		Initial output is low. Low output at compare match.
0	0	1	0		Initial output is low. High output at compare match.
0	0	1	1		Initial output is low. Toggle output at compare match.
0	1	0	0		Output prohibited
0	1	0	1		Initial output is high. Low output at compare match.
0	1	1	0		Initial output is high. High output at compare match.
0	1	1	1		Initial output is high. Toggle output at compare match.
1	x	0	0	Input capture register*1	Input capture at rising edge.
1	x	0	1		Input capture at falling edge.
1	x	1	x		Input capture at both edges.

Remarks: x: Don't care

Note 1. When the BFB bit in MTU7.TMDR1 is set to 1 and MTU7.TGRD register is used as a buffer register, this setting is invalid and input capture/output compare is not generated.

Table 16.26 TIORH (MTU8)

Bit 7	Bit 6	Bit 5	Bit 4	Description	
IOB3	IOB2	IOB1	IOB0	MTU8.TGRB Function	MTIOC8B Pin Function
0	0	0	0	Output compare register	Output prohibited
0	0	0	1		Initial output is low. Low output at compare match.
0	0	1	0		Initial output is low. High output at compare match.
0	0	1	1		Initial output is low. Toggle output at compare match.
0	1	0	0		Output prohibited
0	1	0	1		Initial output is high. Low output at compare match.
0	1	1	0		Initial output is high. High output at compare match.
0	1	1	1		Initial output is high. Toggle output at compare match.
1	0	0	0	Input capture register	Input capture at rising edge.
1	0	0	1		Input capture at falling edge.
1	0	1	x		Input capture at both edges.
1	1	x	x		Capture input source is the clock source for counting in MTU1. Input capture on counting up or down by MTU1.TCNT (LWA = 0) or MTU1.TCNTLW (LWA = 1)*1

Remarks: x: Don't care

Note 1. Input capture will not be generated in MTU8 if P0 ϕ /1 is selected as the count clock for MTU1. Select a clock other than P0 ϕ /1.

Table 16.27 TIORL (MTU8)

Bit 7	Bit 6	Bit 5	Bit 4	Description	
IOD3	IOD2	IOD1	IOD0	MTU8.TGRD Function	MTIOC8D Pin Function
0	0	0	0	Output compare register*1	Output prohibited
0	0	0	1		Initial output is low. Low output at compare match.
0	0	1	0		Initial output is low. High output at compare match.
0	0	1	1		Initial output is low. Toggle output at compare match.
0	1	0	0		Output prohibited
0	1	0	1		Initial output is high. Low output at compare match.
0	1	1	0		Initial output is high. High output at compare match.
0	1	1	1		Initial output is high. Toggle output at compare match.
1	x	0	0	Input capture register	Input capture at rising edge.
1	x	0	1		Input capture at falling edge.
1	x	1	x		Input capture at both edges.

Remarks: x: Don't care

Note 1. When the BFB bit of the TMDR1 register is set to 1 and the TGRD register is used as a buffer register in MTU8, this setting is invalid and input capture/output compare is not generated.

Table 16.28 TIORH (MTU0)

Bit 3	Bit 2	Bit 1	Bit 0	Description	
IOA3	IOA2	IOA1	IOA0	MTU0.TGRA Function	MTIOC0A Pin Function
0	0	0	0	Output compare register	Output prohibited
0	0	0	1		Initial output is low. Low output at compare match.
0	0	1	0		Initial output is low. High output at compare match.
0	0	1	1		Initial output is low. Toggle output at compare match.
0	1	0	0		Output prohibited
0	1	0	1		Initial output is high. Low output at compare match.
0	1	1	0		Initial output is high. High output at compare match.
0	1	1	1		Initial output is high. Toggle output at compare match.
1	0	0	0	Input capture register	Input capture at rising edge.
1	0	0	1		Input capture at falling edge.
1	0	1	x		Input capture at both edges.
1	1	0	0		Capture input source is the clock source for counting in MTU1. Input capture on counting up or down by TCNT (LWA = 0) or TCNTLW (LWA = 1) in MTU1*1
1	1	1	x		Input capture on generation of compare match with MTU8.TGRC

Remarks: x: Don't care

Note 1. Input capture will not be generated in MTU0 if P0φ/1 is selected as the count clock for MTU1. Select a clock other than P0φ/1.

Table 16.29 TIORL (MTU0)

Bit 3	Bit 2	Bit 1	Bit 0	Description	
IOC3	IOC2	IOC1	IOC0	MTU0.TGRC Function	MTIOC0C Pin Function
0	0	0	0	Output compare register*1	Output prohibited
0	0	0	1		Initial output is low. Low output at compare match.
0	0	1	0		Initial output is low. High output at compare match.
0	0	1	1		Initial output is low. Toggle output at compare match.
0	1	0	0		Output prohibited
0	1	0	1		Initial output is high. Low output at compare match.
0	1	1	0		Initial output is high. High output at compare match.
0	1	1	1		Initial output is high. Toggle output at compare match.
1	0	0	0	Input capture register*1	Input capture at rising edge.
1	0	0	1		Input capture at falling edge.
1	0	1	x		Input capture at both edges.
1	1	x	x		Capture input source is the clock source for counting in MTU1. Input capture on counting up or down by TCNT (LWA = 0) or TCNTLW (LWA = 1) in MTU1*2

Remarks: x: Don't care

Note 1. When the BFA bit in MTU0.TMDR1 is set to 1 and MTU0.TGRC is used as a buffer register, this setting is invalid and input capture/output compare is not generated.

Note 2. Input capture will not be generated in MTU0 if P0φ/1 is selected as the count clock for MTU1. Select a clock other than P0φ/1.

Table 16.30 TIOR (MTU1)

Bit 3	Bit 2	Bit 1	Bit 0	Description	
IOA3	IOA2	IOA1	IOA0	MTU1.TGRA/TGRALW Function	MTIOC1A Pin Function
0	0	0	0	Output compare register	Output prohibited
0	0	0	1		Initial output is low. Low output at compare match.
0	0	1	0		Initial output is low. High output at compare match.
0	0	1	1		Initial output is low. Toggle output at compare match.
0	1	0	0		Output prohibited
0	1	0	1		Initial output is high. Low output at compare match.
0	1	1	0		Initial output is high. High output at compare match.
0	1	1	1		Initial output is high. Toggle output at compare match.
1	0	0	0	Input capture register	Input capture at rising edge.
1	0	0	1		Input capture at falling edge.
1	0	1	x		Input capture at both edges.
1	1	x	x		Input capture at generation of MTU0.TGRA compare match/input capture.

Remarks: x: Don't care

Table 16.31 TIOR (MTU2)

Bit 3	Bit 2	Bit 1	Bit 0	Description	
IOA3	IOA2	IOA1	IOA0	MTU2.TGRA Function	MTIOC2A Pin Function
0	0	0	0	Output compare register	Output prohibited
0	0	0	1		Initial output is low. Low output at compare match.
0	0	1	0		Initial output is low. High output at compare match.
0	0	1	1		Initial output is low. Toggle output at compare match.
0	1	0	0		Output prohibited
0	1	0	1		Initial output is high. Low output at compare match.
0	1	1	0		Initial output is high. High output at compare match.
0	1	1	1		Initial output is high. Toggle output at compare match.
1	x	0	0	Input capture register	Input capture at rising edge.
1	x	0	1		Input capture at falling edge.
1	x	1	x		Input capture at both edges.

Remarks: x: Don't care

Table 16.32 TIORH (MTU3)

Bit 3	Bit 2	Bit 1	Bit 0	Description	
IOA3	IOA2	IOA1	IOA0	MTU3.TGRA Function	MTIOC3A Pin Function
0	0	0	0	Output compare register	Output prohibited
0	0	0	1		Initial output is low. Low output at compare match.
0	0	1	0		Initial output is low. High output at compare match.
0	0	1	1		Initial output is low. Toggle output at compare match.
0	1	0	0		Output prohibited
0	1	0	1		Initial output is high. Low output at compare match.
0	1	1	0		Initial output is high. High output at compare match.
0	1	1	1		Initial output is high. Toggle output at compare match.
1	x	0	0	Input capture register	Input capture at rising edge.
1	x	0	1		Input capture at falling edge.
1	x	1	x		Input capture at both edges.

Remarks: x: Don't care

Table 16.33 TIORL (MTU3)

Bit 3	Bit 2	Bit 1	Bit 0	Description	
IOC3	IOC2	IOC1	IOC0	MTU3.TGRC Function	MTIOC3C Pin Function
0	0	0	0	Output compare register*1	Output prohibited
0	0	0	1		Initial output is low. Low output at compare match.
0	0	1	0		Initial output is low. High output at compare match.
0	0	1	1		Initial output is low. Toggle output at compare match.
0	1	0	0		Output prohibited
0	1	0	1		Initial output is high. Low output at compare match.
0	1	1	0		Initial output is high. High output at compare match.
0	1	1	1		Initial output is high. Toggle output at compare match.
1	x	0	0	Input capture register*1	Input capture at rising edge.
1	x	0	1		Input capture at falling edge.
1	x	1	x		Input capture at both edges.

Remarks: x: Don't care

Note 1. When the BFA bit in MTU3.TMDR1 is set to 1 and MTU3.TGRC is used as a buffer register, this setting is invalid and input capture/output compare is not generated.

Table 16.34 TIORH (MTU4)

Bit 3	Bit 2	Bit 1	Bit 0	Description	
IOA3	IOA2	IOA1	IOA0	MTU4.TGRA Function	MTIOC4A Pin Function
0	0	0	0	Output compare register	Output prohibited
0	0	0	1		Initial output is low. Low output at compare match.
0	0	1	0		Initial output is low. High output at compare match.
0	0	1	1		Initial output is low. Toggle output at compare match.
0	1	0	0		Output prohibited
0	1	0	1		Initial output is high. Low output at compare match.
0	1	1	0		Initial output is high. High output at compare match.
0	1	1	1		Initial output is high. Toggle output at compare match.
1	x	0	0	Input capture register	Input capture at rising edge.
1	x	0	1		Input capture at falling edge.
1	x	1	x		Input capture at both edges.

Remarks: x: Don't care

Table 16.35 TIORL (MTU4)

Bit 3	Bit 2	Bit 1	Bit 0	Description	
IOC3	IOC2	IOC1	IOC0	MTU4.TGRC Function	MTIOC4C Pin Function
0	0	0	0	Output compare register*1	Output prohibited
0	0	0	1		Initial output is low. Low output at compare match.
0	0	1	0		Initial output is low. High output at compare match.
0	0	1	1		Initial output is low. Toggle output at compare match.
0	1	0	0		Output prohibited
0	1	0	1		Initial output is high. Low output at compare match.
0	1	1	0		Initial output is high. High output at compare match.
0	1	1	1		Initial output is high. Toggle output at compare match.
1	x	0	0	Input capture register*1	Input capture at rising edge.
1	x	0	1		Input capture at falling edge.
1	x	1	x		Input capture at both edges.

Remarks: x: Don't care

Note 1. When the BFA bit in MTU4.TMDR1 is set to 1 and MTU4.TGRC register is used as a buffer register, this setting is invalid and input capture/output compare is not generated.

Table 16.36 TIORH (MTU6)

Bit 3	Bit 2	Bit 1	Bit 0	Description	
IOA3	IOA2	IOA1	IOA0	MTU6.TGRA Function	MTIOC6A Pin Function
0	0	0	0	Output compare register	Output prohibited
0	0	0	1		Initial output is low. Low output at compare match.
0	0	1	0		Initial output is low. High output at compare match.
0	0	1	1		Initial output is low. Toggle output at compare match.
0	1	0	0		Output prohibited
0	1	0	1		Initial output is high. Low output at compare match.
0	1	1	0		Initial output is high. High output at compare match.
0	1	1	1		Initial output is high. Toggle output at compare match.
1	x	0	0	Input capture register	Input capture at rising edge.
1	x	0	1		Input capture at falling edge.
1	x	1	x		Input capture at both edges.

Remarks: x: Don't care

Table 16.37 TIORL (MTU6)

Bit 3	Bit 2	Bit 1	Bit 0	Description	
IOC3	IOC2	IOC1	IOC0	MTU6.TGRC Function	MTIOC6C Pin Function
0	0	0	0	Output compare register*1	Output prohibited
0	0	0	1		Initial output is low. Low output at compare match.
0	0	1	0		Initial output is low. High output at compare match.
0	0	1	1		Initial output is low. Toggle output at compare match.
0	1	0	0		Output prohibited
0	1	0	1		Initial output is high. Low output at compare match.
0	1	1	0		Initial output is high. High output at compare match.
0	1	1	1		Initial output is high. Toggle output at compare match.
1	x	0	0	Input capture register*1	Input capture at rising edge.
1	x	0	1		Input capture at falling edge.
1	x	1	x		Input capture at both edges.

Remarks: x: Don't care

Note 1. When the BFA bit in MTU6.TMDR1 is set to 1 and MTU6.TGRC register is used as a buffer register, this setting is invalid and input capture/output compare is not generated.

Table 16.38 TIORH (MTU7)

Bit 3	Bit 2	Bit 1	Bit 0	Description	
IOA3	IOA2	IOA1	IOA0	MTU7.TGRA Function	MTIOC7A Pin Function
0	0	0	0	Output compare register	Output prohibited
0	0	0	1		Initial output is low. Low output at compare match.
0	0	1	0		Initial output is low. High output at compare match.
0	0	1	1		Initial output is low. Toggle output at compare match.
0	1	0	0		Output prohibited
0	1	0	1		Initial output is high. Low output at compare match.
0	1	1	0		Initial output is high. High output at compare match.
0	1	1	1		Initial output is high. Toggle output at compare match.
1	x	0	0	Input capture register	Input capture at rising edge.
1	x	0	1		Input capture at falling edge.
1	x	1	x		Input capture at both edges.

Remarks: x: Don't care

Table 16.39 TIORL (MTU7)

Bit 3	Bit 2	Bit 1	Bit 0	Description	
IOC3	IOC2	IOC1	IOC0	MTU7.TGRC Function	MTIOC7C Pin Function
0	0	0	0	Output compare register*1	Output prohibited
0	0	0	1		Initial output is low. Low output at compare match.
0	0	1	0		Initial output is low. High output at compare match.
0	0	1	1		Initial output is low. Toggle output at compare match.
0	1	0	0		Output prohibited
0	1	0	1		Initial output is high. Low output at compare match.
0	1	1	0		Initial output is high. High output at compare match.
0	1	1	1		Initial output is high. Toggle output at compare match.
1	x	0	0	Input capture register*1	Input capture at rising edge.
1	x	0	1		Input capture at falling edge.
1	x	1	x		Input capture at both edges.

Remarks: x: Don't care

Note 1. When the BFA bit in MTU7.TMDR1 is set to 1 and MTU7.TGRC register is used as a buffer register, this setting is invalid and input capture/output compare is not generated.

Table 16.40 TIORH (MTU8)

Bit 3	Bit 2	Bit 1	Bit 0	Description	
IOA3	IOA2	IOA1	IOA0	MTU8.TGRA Function	MTIOC8A Pin Function
0	0	0	0	Output compare register	Output prohibited
0	0	0	1		Initial output is low. Low output at compare match.
0	0	1	0		Initial output is low. High output at compare match.
0	0	1	1		Initial output is low. Toggle output at compare match.
0	1	0	0		Output prohibited
0	1	0	1		Initial output is high. Low output at compare match.
0	1	1	0		Initial output is high. High output at compare match.
0	1	1	1		Initial output is high. Toggle output at compare match.
1	0	0	0	Input capture register	Input capture at rising edge.
1	0	0	1		Input capture at falling edge.
1	x	1	x		Input capture at both edges.

Remarks: x: Don't care

Table 16.41 TIORL (MTU8)

Bit 3	Bit 2	Bit 1	Bit 0	Description	
IOC3	IOC2	IOC1	IOC0	MTU8.TGRC Function	MTIOC8C Pin Function
0	0	0	0	Output compare register*1	Output prohibited
0	0	0	1		Initial output is low. Low output at compare match.
0	0	1	0		Initial output is low. High output at compare match.
0	0	1	1		Initial output is low. Toggle output at compare match.
0	1	0	0		Output prohibited
0	1	0	1		Initial output is high. Low output at compare match.
0	1	1	0		Initial output is high. High output at compare match.
0	1	1	1		Initial output is high. Toggle output at compare match.
1	x	0	0	Input capture register	Input capture at rising edge.
1	x	0	1		Input capture at falling edge.
1	x	1	x		Input capture at both edges.

Remarks: x: Don't care

Note 1. When the MTU8.TMDR1.BFA bit is set to 1 and the MTU8.TGRC register is used as a buffer register, this setting is invalid and input capture/output compare is not generated.

Table 16.42 TIORU, TIORV, and TIORW (MTU5)

Bit 4	Bit 3	Bit 2	Bit 1	Bit 0	Description	
IOC4	IOC3	IOC2	IOC1	IOC0	MTU5.TGRU, MTU5.TGRV, MTU5.TGRW Function	MTIC5U, MTIC5V, MTIC5W Pin Function
0	0	0	0	0	Output compare register	No function
0	0	0	0	1		Setting prohibited
0	0	0	1	x		Setting prohibited
0	0	1	x	x		Setting prohibited
0	1	x	x	x		Setting prohibited
1	0	0	0	0	Input capture register*1	Setting prohibited
1	0	0	0	1		Input capture at rising edge.
1	0	0	1	0		Input capture at falling edge.
1	0	0	1	1		Input capture at both edges.
1	0	1	x	x		Input capture on generation of compare match with MTU8.TGRC
1	1	0	0	0		Setting prohibited
1	1	0	0	1		Measurement of low pulse width of external input signal. Capture at trough in complementary PWM mode.
1	1	0	1	0		Measurement of low pulse width of external input signal. Capture at crest of complementary PWM mode.
1	1	0	1	1		Measurement of low pulse width of external input signal. Capture at crest and trough of complementary PWM mode.
1	1	1	0	0		Setting prohibited
1	1	1	0	1		Measurement of high pulse width of external input signal. Capture at trough in complementary PWM mode.
1	1	1	1	0		Measurement of high pulse width of external input signal. Capture at crest of complementary PWM mode.
1	1	1	1	1		Measurement of high pulse width of external input signal. Capture at crest and trough of complementary PWM mode.

Remarks: x: Don't care

Note 1. Setting the IOC[4:0] bits to "H'19", "H'1A", "H'1B", "H'1D", "H'1E", or "H'1F" is only allowed when the external pulse width measurement function is used or the dead time compensation function, in coordination with MTU6 and MTU7, is used. For details, refer to **Section 16.3.11, External Pulse Width Measurement**, and **Section 16.3.12, Dead Time Compensation**.

16.2.7 Timer Compare Match Clear Register (TCNTCMPCLR)

Address(es): MTU5.TCNTCMPCLR H'0_1000_1CB6

Bit	b7	b6	b5	b4	b3	b2	b1	b0
	—	—	—	—	—	CMPCLR5U	CMPCLR5V	CMPCLR5W
Initial Value	0	0	0	0	0	0	0	0
R/W	R/W	R/W	R/W	R/W	R/W	R/W	R/W	R/W

Bit	Bit Name	Initial Value	R/W	Description
b0	CMPCLR5W	0	R/W	TCNT Compare Clear 5W 0: Disables MTU5.TCNTW to be cleared to H'0000 at MTU5.TCNTW and MTU5.TGRW compare match or input capture 1: Enables MTU5.TCNTW to be cleared to H'0000 at MTU5.TCNTW and MTU5.TGRW compare match or input capture
b1	CMPCLR5V	0	R/W	TCNT Compare Clear 5V 0: Disables MTU5.TCNTV to be cleared to H'0000 at MTU5.TCNTV and MTU5.TGRV compare match or input capture 1: Enables MTU5.TCNTV to be cleared to H'0000 at MTU5.TCNTV and MTU5.TGRV compare match or input capture
b2	CMPCLR5U	0	R/W	TCNT Compare Clear 5U 0: Disables MTU5.TCNTU to be cleared to H'0000 at MTU5.TCNTU and MTU5.TGRU compare match or input capture 1: Enables MTU5.TCNTU to be cleared to H'0000 at MTU5.TCNTU and MTU5.TGRU compare match or input capture
b7 to b3	—	All 0	R/W	Reserved These bits are read as 0. The write value should be 0.

TCNTCMPCLR specifies requests to clear MTU5.TCNTU, MTU5.TCNTV, and MTU5.TCNTW. The MTU has one TCNTCMPCLR (on MTU5).

16.2.8 Timer Interrupt Enable Register (TIER)

(1) MTU1.TIER, MTU2.TIER

Address(es): MTU1.TIER H'0_1000_1384, MTU2.TIER H'0_1000_1404

Bit	b7	b6	b5	b4	b3	b2	b1	b0
	TTGE	—	TCIEU	TCIEV	—	—	TGIEB	TGIEA
Initial Value	0	0	0	0	0	0	0	0
	R/W	R/W	R/W	R/W	R/W	R/W	R/W	R/W

(2) MTU0.TIER, MTU3.TIER, MTU6.TIER

Address(es): MTU0.TIER H'0_1000_1304, MTU3.TIER H'0_1000_1208, MTU6.TIER H'0_1000_1A08

Bit	b7	b6	b5	b4	b3	b2	b1	b0
	TTGE	—	—	TCIEV	TGIED	TGIEC	TGIEB	TGIEA
Initial Value	0	0	0	0	0	0	0	0
	R/W	R/W	R/W	R/W	R/W	R/W	R/W	R/W

(3) MTU4.TIER, MTU7.TIER

Address(es): MTU4.TIER H'0_1000_1209, MTU7.TIER H'0_1000_1A09

Bit	b7	b6	b5	b4	b3	b2	b1	b0
	TTGE	TTGE2	—	TCIEV	TGIED	TGIEC	TGIEB	TGIEA
Initial Value	0	0	0	0	0	0	0	0
	R/W	R/W	R/W	R/W	R/W	R/W	R/W	R/W

(4) MTU8.TIER

Address(es): MTU8.TIER H'0_1000_1604

Bit	b7	b6	b5	b4	b3	b2	b1	b0
	—	—	—	TCIEV	TGIED	TGIEC	TGIEB	TGIEA
Initial Value	0	0	0	0	0	0	0	0
	R/W	R/W	R/W	R/W	R/W	R/W	R/W	R/W

Bit	Bit Name	Initial Value	R/W	Description
b0	TGIEA	0	R/W	TGR Interrupt Enable A 0: Interrupt requests (TGIA) disabled 1: Interrupt requests (TGIA) enabled
b1	TGIEB	0	R/W	TGR Interrupt Enable B 0: Interrupt requests (TGIB) disabled 1: Interrupt requests (TGIB) enabled
b2	TGIEC	0	R/W	TGR Interrupt Enable C 0: Interrupt requests (TGIC) disabled 1: Interrupt requests (TGIC) enabled
b3	TGIED	0	R/W	TGR Interrupt Enable D 0: Interrupt requests (TGID) disabled 1: Interrupt requests (TGID) enabled
b4	TCIEV	0	R/W	Overflow Interrupt Enable 0: Interrupt requests (TCIV) disabled 1: Interrupt requests (TCIV) enabled
b5	TCIEU	0	R/W	Underflow Interrupt Enable 0: Interrupt requests (TCIU) disabled 1: Interrupt requests (TCIU) enabled
b6	TTGE2	0	R/W	A/D Converter Start Request Enable 2 0: A/D converter start request generation by MTUn.TCNT underflow (trough) disabled 1: A/D converter start request generation by MTUn.TCNT underflow (trough) enabled
b7	TTGE	0	R/W	A/D Converter Start Request Enable 0: A/D converter start request generation disabled 1: A/D converter start request generation enabled

Note: n = 4, 7

The TIER register enables or disables interrupt requests from each channel. The MTU has a total of ten TIER registers, two for MTU0 and one each for MTU1 to MTU8.

TGIEA and TGIEB Bits (TGR Interrupt Enable A and B)

Each bit enables or disables interrupt requests (TGIn) (n = A, B).

TGIEC and TGIED Bits (TGR Interrupt Enable C and D)

Each bit enables or disables an interrupt request (TGIn) (n = C, D).

In MTU1 and MTU2, these bits are reserved. They are read as 0. The write value should be 0.

TCIEV Bit (Overflow Interrupt Enable)

This bit enables or disables interrupt requests (TCIV).

TCIEU Bit (Underflow Interrupt Enable)

This bit enables or disables interrupt requests (TCIU).

In MTU0, MTU3, MTU4, MTU6, MTU7, and MTU8, this bit is reserved. It is read as 0. The write value should be 0.

TTGE2 Bit (A/D Converter Start Request Enable 2)

This bit enables or disables generation of A/D converter start requests by MTUn.TCNT underflow (trough) in complementary PWM mode (n = 4, 7).

In MTU0 to MTU3, MTU6, and MTU8, this bit is reserved. It is read as 0. The write value should be 0.

TTGE Bit (A/D Converter Start Request Enable)

This bit enables or disables generation of A/D converter start requests by TGRA input capture/compare match. MTU8 is a reserved bit. It is read as 0. The write value should be 0.

(5) MTU0.TIER2

Address(es): MTU0.TIER2 H'0_1000_1324

Bit	b7	b6	b5	b4	b3	b2	b1	b0
	TTGE2	—	—	—	—	—	TGIEF	TGIEE
Initial Value	0	0	0	0	0	0	0	0
R/W	R/W	R/W	R/W	R/W	R/W	R/W	R/W	R/W

Bit	Bit Name	Initial Value	R/W	Description
b0	TGIEE	0	R/W	TGR Interrupt Enable E 0: Interrupt requests (TGIE) disabled 1: Interrupt requests (TGIE) enabled
b1	TGIEF	0	R/W	TGR Interrupt Enable F 0: Interrupt requests (TGIF) disabled 1: Interrupt requests (TGIF) enabled
b6 to b2	—	All 0	R/W	Reserved These bits are read as 0. The write value should be 0.
b7	TTGE2	0	R/W	A/D Converter Start Request Enable 2 0: A/D converter start request generation by compare match between MTU0.TCNT and MTU0.TGRE disabled 1: A/D converter start request generation by compare match between MTU0.TCNT and MTU0.TGRE enabled

TGIEE and TGIEF Bits (TGR Interrupt Enable E and F)

Each bit enables or disables interrupt requests by compare match between MTU0.TCNT and MTU0.TGRn (n = E, F).

TTGE2 Bit (A/D Converter Start Request Enable 2)

This bit enables or disables AD converter start requests by compare match between TCNT and TGRE in MTU0.

(6) MTU5.TIER

Address(es): MTU5.TIER H'0_1000_1CB2

Bit	b7	b6	b5	b4	b3	b2	b1	b0
	—	—	—	—	—	TGIE5U	TGIE5V	TGIE5W
Initial Value	0	0	0	0	0	0	0	1
R/W	R/W	R/W	R/W	R/W	R/W	R/W	R/W	R/W

Bit	Bit Name	Initial Value	R/W	Description
b0	TGIE5W	0	R/W	TGR Interrupt Enable 5W 0: Interrupt requests TGIW5 disabled 1: Interrupt requests TGIW5 enabled
b1	TGIE5V	0	R/W	TGR Interrupt Enable 5V 0: Interrupt requests TGIV5 disabled 1: Interrupt requests TGIV5 enabled
b2	TGIE5U	0	R/W	TGR Interrupt Enable 5U 0: Interrupt requests TGIU5 disabled 1: Interrupt requests TGIU5 enabled
b7 to b3	—	All 0	R/W	Reserved These bits are read as 0. The write value should be 0.

TGIE5n Bits (TGR Interrupt Enable 5n)

Each bit enables or disables interrupt requests (TGIn5) (n = U, V, W).

16.2.9 Timer Status Register (TSR)

(1) MTU1.TSR, MTU2.TSR

Address(es): MTU1.TSR H'0_1000_1385, MTU2.TSR H'0_1000_1405

Bit	b7	b6	b5	b4	b3	b2	b1	b0
	TCFD	—	—	—	—	—	—	—
Initial Value	1	1	0	0	0	0	0	0
R/W	R	R/W	R/W	R/W	R/W	R/W	R/W	R/W

(2) MTU3.TSR, MTU4.TSR, MTU6.TSR, MTU7.TSR

Address(es): MTU3.TSR H'0_1000_122C, MTU4.TSR H'0_1000_122D, MTU6.TSR H'0_1000_1A2C,
MTU7.TSR H'0_1000_1A2D

Bit	b7	b6	b5	b4	b3	b2	b1	b0
	TCFD	—	—	—	—	—	—	—
Initial Value	1	1	0	0	0	0	0	0
R/W	R	R/W	R/W	R/W	R/W	R/W	R/W	R/W

Bit	Bit Name	Initial Value	R/W	Description
b5 to b0	—	All 0	R/W	Reserved The read value is undefined. The write value should be 1.
b6	—	1	R/W	Reserved This bit is read as 1. The write value should be 1.
b7	TCFD	1	R	Count Direction Flag 0: TCNT counts down 1: TCNT counts up

TSR indicates the states of each of the channels. The MTU has a total of six TSR registers, one each for MTU1 to MTU4, MTU6, and MTU7.

TCFD Flag (Count Direction Flag)

Status flag that indicates the direction in which TCNT is counting in MTU1 to MTU4, MTU6, and MTU7.

16.2.10 Timer Buffer Operation Transfer Mode Register (TBTM)

(1) MTU0.TBTM

Address(es): MTU0.TBTM H'0_1000_1326

Bit	b7	b6	b5	b4	b3	b2	b1	b0
	—	—	—	—	—	TTSE	TTSB	TTSA
Initial Value	0	0	0	0	0	0	0	0
R/W	R/W	R/W	R/W	R/W	R/W	R/W	R/W	R/W

(2) MTU3.TBTM, MTU4.TBTM, MTU6.TBTM, MTU7.TBTM

Address(es): MTU3.TBTM H'0_1000_1238, MTU4.TBTM H'0_1000_1239, MTU6.TBTM H'0_1000_1A38, MTU7.TBTM H'0_1000_1A39

Bit	b7	b6	b5	b4	b3	b2	b1	b0
	—	—	—	—	—	—	TTSB	TTSA
Initial Value	0	0	0	0	0	0	0	0
R/W	R/W	R/W	R/W	R/W	R/W	R/W	R/W	R/W

Bit	Bit Name	Initial Value	R/W	Description
b0	TTSA	0	R/W	Timing Select A 0: When compare match A occurs in each channel, data is transferred from TGRC to TGRA 1: When TCNT is cleared in each channel, data is transferred from TGRC to TGRA
b1	TTSB	0	R/W	Timing Select B 0: When compare match B occurs in each channel, data is transferred from TGRD to TGRB 1: When TCNT is cleared in each channel, data is transferred from TGRD to TGRB
b2	TTSE	0	R/W	Timing Select E 0: When compare match E occurs in MTU0, data is transferred from MTU0.TGRF to MTU0.TGRE 1: When MTU0.TCNT is cleared in MTU0, data is transferred from MTU0.TGRF to MTU0.TGRE
b7 to b3	—	All 0	R/W	Reserved These bits are read as 0. The write value should be 0.

TBTM specifies the timing for transferring data from the buffer register to the timer general register in PWM mode. The MTU has a total of five TBTM registers, one each for MTU0, MTU3, MTU4, MTU6, and MTU7.

TTSA Bit (Timing Select A)

This bit specifies the timing for transferring data from TGRC to TGRA in each channel when they are used together for buffer operation. When a channel is not set to PWM mode, do not set the TTSA bit in the channel to 1.

TTSB Bit (Timing Select B)

This bit specifies the timing for transferring data from TGRD to TGRB in each channel when they are used together for buffer operation. When a channel is not set to PWM mode, do not set the TTSB bit in the channel to 1.

TTSE Bit (Timing Select E)

This bit specifies the timing for transferring data from MTU0.TGRF to MTU0.TGRE when they are used together for buffer operation.

In MTU3, MTU4, MTU6, and MTU7, this bit is reserved. It is read as 0 and the write value should be 0. When a channel is not set to PWM mode, do not set the TTSE bit in the channel to 1.

16.2.11 Timer Input Capture Control Register (TICCR)

Address(es): MTU1.TICCR H'0_1000_1390

Bit	b7	b6	b5	b4	b3	b2	b1	b0
	—	—	—	—	I2BE	I2AE	I1BE	I1AE
Initial Value	0	0	0	0	0	0	0	0
R/W	R/W	R/W	R/W	R/W	R/W	R/W	R/W	R/W

Bit	Bit Name	Initial Value	R/W	Description
b0	I1AE	0	R/W	Input Capture Enable 0: Does not include the MTIOC1A pin in the MTU2.TGRA input capture conditions 1: Includes the MTIOC1A pin in the MTU2.TGRA input capture conditions
b1	I1BE	0	R/W	Input Capture Enable 0: Does not include the MTIOC1B pin in the MTU2.TGRB input capture conditions 1: Includes the MTIOC1B pin in the MTU2.TGRB input capture conditions
b2	I2AE	0	R/W	Input Capture Enable 0: Does not include the MTIOC2A pin in the MTU1.TGRA input capture conditions 1: Includes the MTIOC2A pin in the MTU1.TGRA input capture conditions
b3	I2BE	0	R/W	Input Capture Enable 0: Does not include the MTIOC2B pin in the MTU1.TGRB input capture conditions 1: Includes the MTIOC2B pin in the MTU1.TGRB input capture conditions
b7 to b4	—	All 0	R/W	Reserved These bits are read as 0. The write value should be 0.

TICCR specifies input capture conditions when MTU1.TCNT and MTU2.TCNT are cascaded. The MTU has one TICCR for MTU1.

16.2.12 Timer Synchronous Clear Register (TSYCR)

Address(es): MTU6.TSYCR H'0_1000_1A50

Bit	b7	b6	b5	b4	b3	b2	b1	b0
	CE0A	CE0B	CE0C	CE0D	CE1A	CE1B	CE2A	CE2B
Initial Value	0	0	0	0	0	0	0	0
R/W	R/W	R/W	R/W	R/W	R/W	R/W	R/W	R/W

Bit	Bit Name	Initial Value	R/W	Description
b0	CE2B	0	R/W	Clear Enable 2B 0: Disables counter clearing by the MTU2.TGIB2 interrupt generation timing. 1: Enables counter clearing by the MTU2.TGIB2 interrupt generation timing.
b1	CE2A	0	R/W	Clear Enable 2A 0: Disables counter clearing by the MTU2.TGIA2 interrupt generation timing* ¹ . 1: Enables counter clearing by the MTU2.TGIA2 interrupt generation timing* ¹ .
b2	CE1B	0	R/W	Clear Enable 1B 0: Disables counter clearing by the MTU1.TGIB1 interrupt generation timing* ¹ . 1: Enables counter clearing by the MTU1.TGIB1 interrupt generation timing* ¹ .
b3	CE1A	0	R/W	Clear Enable 1A 0: Disables counter clearing by the MTU1.TGIA1 interrupt generation timing* ¹ . 1: Enables counter clearing by the MTU1.TGIA1 interrupt generation timing* ¹ .
b4	CE0D	0	R/W	Clear Enable 0D 0: Disables counter clearing by the MTU0.TGID0 interrupt generation timing* ¹ . 1: Enables counter clearing by the MTU0.TGID0 interrupt generation timing* ¹ .
b5	CE0C	0	R/W	Clear Enable 0C 0: Disables counter clearing by the MTU0.TGIC0 interrupt generation timing* ¹ . 1: Enables counter clearing by the MTU0.TGIC0 interrupt generation timing* ¹ .
b6	CE0B	0	R/W	Clear Enable 0B 0: Disables counter clearing by the MTU0.TGIB0 interrupt generation timing* ¹ . 1: Enables counter clearing by the MTU0.TGIB0 interrupt generation timing* ¹ .
b7	CE0A	0	R/W	Clear Enable 0A 0: Disables counter clearing by the MTU0.TGIA0 interrupt generation timing* ¹ . 1: Enables counter clearing by the MTU0.TGIA0 interrupt generation timing* ¹ .

Note 1. This does not depend on the TIERn.TGIE_m bit setting. (n = 0, 1, 2; m = A, B, C, D)

TSYCR specifies synchronous clear conditions for MTU6.TCNT and MTU7.TCNT. The MTU has one TSYCR for MTU1.

CE_nm Bits (Clear Enable nm; n = 0, 1, 2; m = A, B, C, D)

These bits enable or disable counter clearing by the MTU_n.TGIE_m interrupt generation timing.

16.2.13 Timer Counter (TCNT)

(1) MTU0.TCNT to MTU7.TCNT

Address(es): MTU0.TCNT H'0_1000_1306, MTU1.TCNT H'0_1000_1386, MTU2.TCNT H'0_1000_1406,
MTU3.TCNT H'0_1000_1210, MTU4.TCNT H'0_1000_1212, MTU5.TCNTU H'0_1000_1C80,
MTU5.TCNTV H'0_1000_1C90, MTU5.TCNTW H'0_1000_1CA0, MTU6.TCNT H'0_1000_1A10,
MTU7.TCNT H'0_1000_1A12

Bit	b15	b14	b13	b12	b11	b10	b9	b8	b7	b6	b5	b4	b3	b2	b1	b0
Initial Value	0	0	0	0	0	0	0	0	0	0	0	0	0	0	0	0
R/W	R/W	R/W	R/W	R/W	R/W	R/W	R/W	R/W	R/W	R/W	R/W	R/W	R/W	R/W	R/W	R/W

Note: TCNT must not be accessed in eight bits; it should be accessed in 16 bits.

(2) MTU8.TCNT

Address(es): MTU8.TCNT H'0_1000_1608

Bit	b31	b30	b29	b28	b27	b26	b25	b24	b23	b22	b21	b20	b19	b18	b17	b16
Initial Value	0	0	0	0	0	0	0	0	0	0	0	0	0	0	0	0
R/W	R/W	R/W	R/W	R/W	R/W	R/W	R/W	R/W	R/W	R/W	R/W	R/W	R/W	R/W	R/W	R/W

Bit	b15	b14	b13	b12	b11	b10	b9	b8	b7	b6	b5	b4	b3	b2	b1	b0
Initial Value	0	0	0	0	0	0	0	0	0	0	0	0	0	0	0	0
R/W	R/W	R/W	R/W	R/W	R/W	R/W	R/W	R/W	R/W	R/W	R/W	R/W	R/W	R/W	R/W	R/W

Note: TCNT must not be accessed in 8 or 16 bits; it should be accessed in 32 bits.

MTU0.TCNT to MTU7.TCNT are 16-bit readable/writable counters and MTU8.TCNT is a 32-bit readable/writable counter. The MTU has a total of 11 TCNT counters, one each for MTU0 to MTU4, MTU6, MTU7, and MTU8 and three (TCNTU, TCNTV, and TCNTW) for MTU5. The TCNT counters in MTU0 to MTU4, MTU6, and MTU7 are initialized to H'0000 by a reset, and the TCNT counter in MTU8 is initialized to H'00000000 by a reset. The TCNTU, TCNTV, and TCNTW counters in MTU5 are initialized to H'0000 by a reset. In MTU0 to MTU4, MTU6, and MTU7, the TCNT counters must not be accessed in 8-bit units; they should be accessed in 16-bit units. The MTU8.TCNT counter must not be accessed in 8- or 16-bit units; it should be accessed in 32-bit units.

The MTU1.TCNT and MTU2.TCNT counters are read as H'0000 when TMDR3.LWA is 1. See **Section 16.2.5, Timer Mode Register 3 (TMDR3)** for details.

16.2.14 Timer Longword Counter (TCNTLW)

Address(es): MTU1.TCNTLW H'0_1000_13A0

Bit	b31	b30	b29	b28	b27	b26	b25	b24	b23	b22	b21	b20	b19	b18	b17	b16
Initial Value	0	0	0	0	0	0	0	0	0	0	0	0	0	0	0	0
R/W	R/W	R/W	R/W	R/W	R/W	R/W	R/W	R/W	R/W	R/W	R/W	R/W	R/W	R/W	R/W	R/W
Bit	b15	b14	b13	b12	b11	b10	b9	b8	b7	b6	b5	b4	b3	b2	b1	b0
Initial Value	0	0	0	0	0	0	0	0	0	0	0	0	0	0	0	0
R/W	R/W	R/W	R/W	R/W	R/W	R/W	R/W	R/W	R/W	R/W	R/W	R/W	R/W	R/W	R/W	R/W

Note: TCNTLW must not be accessed in 8 or 16 bits; it should be accessed in 32 bits.

The TCNTLW counter is a 32-bit readable/writable counter. Only one counter of this type is provided, and is formed by combining MTU1.TCNT and MTU2.TCNT. Such operation is only effective when TMDR3.LWA is 1. The TCNTLW counter is initialized to H'0000 0000 by a reset. This counter is read as H'0000 0000 when TMDR3.LWA is 0. See **Section 16.2.5, Timer Mode Register 3 (TMDR3)** for details. This register can only be used in 32-bit phase counting mode.

16.2.15 Timer General Register (TGR)

(1) MTU0.TGR to MTU7.TGR

Address(es): MTU0.TGRA H'0_1000_1308, MTU0.TGRB H'0_1000_130A, MTU0.TGRC H'0_1000_130C, MTU0.TGRD H'0_1000_130E, MTU0.TGRE H'0_1000_1320, MTU0.TGRF H'0_1000_1322, MTU1.TGRA H'0_1000_1388, MTU1.TGRB H'0_1000_138A, MTU2.TGRA H'0_1000_1408, MTU2.TGRB H'0_1000_140A, MTU3.TGRA H'0_1000_1218, MTU3.TGRB H'0_1000_121A, MTU3.TGRC H'0_1000_1224, MTU3.TGRD H'0_1000_1226, MTU3.TGRE H'0_1000_1272, MTU4.TGRA H'0_1000_121C, MTU4.TGRB H'0_1000_121E, MTU4.TGRC H'0_1000_1228, MTU4.TGRD H'0_1000_122A, MTU4.TGRE H'0_1000_1274, MTU4.TGRF H'0_1000_1276, MTU5.TGRU H'0_1000_1C82, MTU5.TGRV H'0_1000_1C92, MTU5.TGRW H'0_1000_1CA2, MTU6.TGRA H'0_1000_1A18, MTU6.TGRB H'0_1000_1A1A, MTU6.TGRC H'0_1000_1A24, MTU6.TGRD H'0_1000_1A26, MTU6.TGRE H'0_1000_1A72, MTU7.TGRA H'0_1000_1A1C, MTU7.TGRB H'0_1000_1A1E, MTU7.TGRC H'0_1000_1A28, MTU7.TGRD H'0_1000_1A2A, MTU7.TGRE H'0_1000_1A74, MTU7.TGRF H'0_1000_1A76

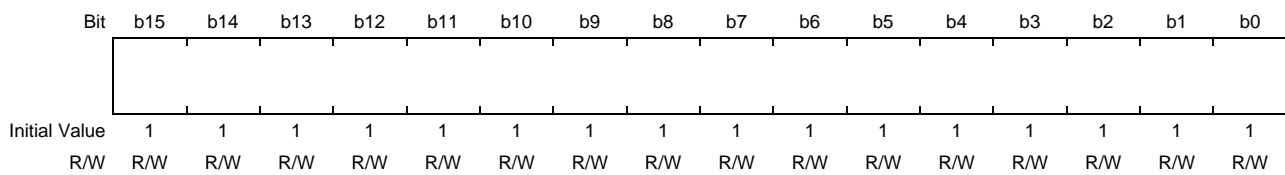

Note: TGR must not be accessed in eight bits; it should be accessed in 16 bits. The initial value of TGR is H'FFFF.

(2) MTU8.TGR

Address(es): MTU8.TGRA H'0_1000_160C, MTU8.TGRB H'0_1000_1610, MTU8.TGRC H'0_1000_1614,
MTU8.TGRD H'0_1000_1618

Bit	b31	b30	b29	b28	b27	b26	b25	b24	b23	b22	b21	b20	b19	b18	b17	b16
Initial Value	1	1	1	1	1	1	1	1	1	1	1	1	1	1	1	1
R/W	R/W	R/W	R/W	R/W	R/W	R/W	R/W	R/W	R/W	R/W	R/W	R/W	R/W	R/W	R/W	R/W

Bit	b15	b14	b13	b12	b11	b10	b9	b8	b7	b6	b5	b4	b3	b2	b1	b0
Initial Value	1	1	1	1	1	1	1	1	1	1	1	1	1	1	1	1
R/W	R/W	R/W	R/W	R/W	R/W	R/W	R/W	R/W	R/W	R/W	R/W	R/W	R/W	R/W	R/W	R/W

Note: TGR must not be accessed in 8 or 16 bits; it should be accessed in 32 bits.

The MTU0.TGR to MTU7.TGR registers are 16-bit readable/writable registers; the MTU8.TGR register is a 32-bit readable/writable register. The MTU has a total of 39 TGR registers, six for MTU0, two each for MTU1 and MTU2, five each for MTU3 and MTU6, six each for MTU4 and MTU7, three for MTU5 and four for MTU8.

The TGRA, TGRB, TGRC, and TGRD registers function as either output compare or input capture registers. The TGRC and TGRD registers for MTU0, MTU3, MTU4, MTU6, MTU7, and MTU8 can also be designated for operation as buffer registers. TGR buffer register combinations are TGRA and TGRC, and TGRB and TGRD.

MTU0.TGRE and MTU0.TGRF function as compare registers. When the MTU0.TCNT count matches the MTU0.TGRE value, an A/D converter start request can be issued. The TGRF register can also be designated for operation as a buffer register. TGR buffer register combination is TGRE and TGRF. MTU5.TGRU, MTU5.TGRV, and MTU5.TGRW function as compare match, input capture, or external pulse width measurement registers.

The MTU1.TGRA, MTU2.TGRA, MTU1.TGRB, and MTU2.TGRB registers are read as H'0000 when TMDR3.LWA is 1. See **Section 16.2.5, Timer Mode Register 3 (TMDR3)** for details.

16.2.16 Timer Longword General Registers (TGRALW and TGRBLW)

Address(es): MTU1.TGRALW H'0_1000_13A4, MTU1.TGRBLW H'0_1000_13A8

Bit	b31	b30	b29	b28	b27	b26	b25	b24	b23	b22	b21	b20	b19	b18	b17	b16
Initial Value	1	1	1	1	1	1	1	1	1	1	1	1	1	1	1	1
R/W	R/W	R/W	R/W	R/W	R/W	R/W	R/W	R/W	R/W	R/W	R/W	R/W	R/W	R/W	R/W	R/W

Bit	b15	b14	b13	b12	b11	b10	b9	b8	b7	b6	b5	b4	b3	b2	b1	b0
Initial Value	1	1	1	1	1	1	1	1	1	1	1	1	1	1	1	1
R/W	R/W	R/W	R/W	R/W	R/W	R/W	R/W	R/W	R/W	R/W	R/W	R/W	R/W	R/W	R/W	R/W

Note: TGRALW and TGRBLW must not be accessed in 8 or 16 bits; they should be accessed in 32 bits.

The TGRALW (TGRBLW) register is a 32-bit readable/writable register. Two general registers of this type are provided, and are formed by combining the TGRA (TGRB) registers in MTU1 and MTU2. Such operation is only effective when TMDR3.LWA is 1.

The TGRALW (TGRBLW) register is initialized to H'FFFF FFFF by a reset, but it is read as H'0000 0000 when TMDR3.LWA is 0. See **Section 16.2.5, Timer Mode Register 3 (TMDR3)** for details.

The TGRALW (TGRBLW) register functions as an output compare or input capture register when TMDR3.LWA is 1. This register can only be used in 32-bit phase counting mode.

16.2.17 Timer Start Registers (TSTRA, TSTRB, and TSTR)

(1) MTU.TSTRA (MTU0, MTU1, MTU2, MTU3, MTU4, MTU8)

Address(es): MTU.TSTRA H'0_1000_1280

Bit	b7	b6	b5	b4	b3	b2	b1	b0
	CST4	CST3	—	—	CST8	CST2	CST1	CST0
Initial Value	0	0	0	0	0	0	0	0
	R/W	R/W	R/W	R/W	R/W	R/W	R/W	R/W

Bit	Bit Name	Initial Value	R/W	Description
b0	CST0	0	R/W	Counter Start 0 0: MTU0.TCNT counting is stopped 1: MTU0.TCNT performs count operation
b1	CST1	0	R/W	Counter Start 1 0: MTU1.TCNT counting is stopped 1: MTU1.TCNT performs count operation
b2	CST2	0	R/W	Counter Start 2 0: MTU2.TCNT counting is stopped 1: MTU2.TCNT performs count operation
b3	CST8	0	R/W	Counter start 8 0: MTU8.TCNT counting is stopped 1: MTU8.TCNT performs count operation.
b5, b4	—	All 0	R/W	Reserved These bits are read as 0. The write value should be 0.
b6	CST3	0	R/W	Counter Start 3 0: MTU3.TCNT counting is stopped 1: MTU3.TCNT performs count operation
b7	CST4	0	R/W	Counter Start 4 0: MTU4.TCNT counting is stopped 1: MTU4.TCNT performs count operation

Note: When 1 is written to a bit in TCSYSTR, the corresponding bit in TSTRA is also set to 1 automatically.

The TSTRA register starts or stops TCNT operation in MTU0 to MTU4 and MTU8. TSTRA starts or stops TCNT operation in MTU0 to MTU4.

TSTRB starts or stops TCNT operation in MTU6 and MTU7. TSTR starts or stops TCNT operation in MTU5.

Before setting the operating mode in TMDR1 or setting the TCNT count clock in TCR, be sure to stop the TCNT counting.

CSTn Bits (Counter Start n) (n = 0, 1, 2, 3, 4, 8)

Each bit starts or stops TCNT in the corresponding channel.

If 0 is written to the CSTn bit during operation with the MTIOC pin designated for output, the counter stops. In this case, the initial output value specified by the TOCR1A or TOCR2A register is output from the MTIOC pin in complementary PWM mode or reset-synchronized PWM mode.

In the other modes, the level of the output compare signal from the MTIOC pin is retained. If TIOR is written to while the CSTn bit is 0, the level of output from the pin will be updated to the specified initial output value.

(2) MTU.TSTRB(MTU6, MTU7)

Address(es): MTU.TSTRB H'0_1000_1A80

Bit	b7	b6	b5	b4	b3	b2	b1	b0
	CST7	CST6	—	—	—	—	—	—
Initial Value	0	0	0	0	0	0	0	0
R/W	R/W	R/W	R/W	R/W	R/W	R/W	R/W	R/W

Bit	Bit Name	Initial Value	R/W	Description
b5 to b0	—	All 0	R/W	Reserved These bits are read as 0. The write value should be 0.
b6	CST6	0	R/W	Counter Start 6 0: MTU6.TCNT counting is stopped 1: MTU6.TCNT performs count operation
b7	CST7	0	R/W	Counter Start 7 0: MTU7.TCNT counting is stopped 1: MTU7.TCNT performs count operation

Note: When 1 is written to a bit in TCSYSTR, the corresponding bit in TSTRB is also set to 1 automatically.

CSTn Bits (Counter Start n) (n = 6, 7)

Each bit starts or stops TCNT in the corresponding channel.

If 0 is written to the CSTn bit during operation with the MTIOC pin designated for output, the counter stops. In this case, the initial output value specified by the TOCR1B or TOCR2B register is output from the MTIOC pin in complementary PWM mode or reset-synchronized PWM mode.

In the other modes, the level of the output compare signal from the MTIOC pin is retained. If TIOR is written to while the CSTn bit is 0, the level of output from the pin will be updated to the specified initial output value.

(3) MTU5.TSTR(MTU5)

Address(es): MTU5.TSTR H'0_1000_1CB4

Bit	b7	b6	b5	b4	b3	b2	b1	b0
	—	—	—	—	—	CSTU5	CSTV5	CSTW5
Initial Value	0	0	0	0	0	0	0	0
R/W	R/W	R/W	R/W	R/W	R/W	R/W	R/W	R/W

Bit	Bit Name	Initial Value	R/W	Description
b0	CSTW5	0	R/W	Counter Start W5 0: MTU5.TCNTW counting is stopped 1: MTU5.TCNTW performs count operation
b1	CSTV5	0	R/W	Counter Start V5 0: MTU5.TCNTV counting is stopped 1: MTU5.TCNTV performs count operation
b2	CSTU5	0	R/W	Counter Start U5 0: MTU5.TCNTU counting is stopped 1: MTU5.TCNTU performs count operation
b7 to b3	—	All 0	R/W	Reserved These bits are read as 0. The write value should be 0.

16.2.18 Timer Synchronous Registers (TSYRA and TSYRB)

(1) MTU.TSYRA(MTU0, MTU1, MTU2, MTU3, MTU4)

Address(es): MTU.TSYRA H'0_1000_1281

Bit	b7	b6	b5	b4	b3	b2	b1	b0
	SYNC4	SYNC3	—	—	—	SYNC2	SYNC1	SYNC0
Initial Value	0	0	0	0	0	0	0	0
	R/W	R/W	R/W	R/W	R/W	R/W	R/W	R/W

Bit	Bit Name	Initial Value	R/W	Description
b0	SYNC0	0	R/W	Timer Synchronous Operation 0 0: MTU0.TCNT operates independently (TCNT setting/clearing is not related to other channels). 1: MTU0.TCNT performs synchronous operation. (TCNT synchronous setting/synchronous clearing is enabled.)
b1	SYNC1	0	R/W	Timer Synchronous Operation 1 0: MTU1.TCNT operates independently (TCNT setting/clearing is not related to other channels). 1: MTU1.TCNT performs synchronous operation. (TCNT synchronous setting/synchronous clearing is enabled.)
b2	SYNC2	0	R/W	Timer Synchronous Operation 2 0: MTU2.TCNT operates independently (TCNT setting/clearing is not related to other channels). 1: MTU2.TCNT performs synchronous operation. (TCNT synchronous setting/synchronous clearing is enabled.)
b5 to b3	—	All 0	R/W	Reserved These bits are read as 0. The write value should be 0.
b6	SYNC3	0	R/W	Timer Synchronous Operation 3 0: MTU3.TCNT operates independently (TCNT setting/clearing is not related to other channels). 1: MTU3.TCNT performs synchronous operation. (TCNT synchronous setting/synchronous clearing is enabled.)
b7	SYNC4	0	R/W	Timer Synchronous Operation 4 0: MTU4.TCNT operates independently (TCNT setting/clearing is not related to other channels). 1: MTU4.TCNT performs synchronous operation. (TCNT synchronous setting/synchronous clearing is enabled.)

TSYRA selects independent operation or synchronous operation of TCNT in MTU0 to MTU4. TSYRB selects independent operation or synchronous operation of TCNT in MTU6 and MTU7. A channel performs synchronous operation when the corresponding bit in TSYR is set to 1.

SYNCn Bits (Timer Synchronous Operation n) (n = 0, 1, 2, 3, 4)

Each bit selects whether operation is independent of or synchronized with other channels.

When synchronous operation is selected, the TCNT synchronous setting of multiple channels and synchronous clearing by counter clearing on another channel are possible.

To set synchronous operation, the SYNC bits for at least two channels must be set to 1. To set synchronous clearing, in addition to the SYNC bit, the TCNT clearing source must also be set by means of the TCR.CCLR[2:0] bits.

(2) MTU.TSYRB(MTU6, MTU7)

Address(es): MTU.TSYRB H'0_1000_1A81

Bit	b7	b6	b5	b4	b3	b2	b1	b0
	SYNC7	SYNC6	—	—	—	—	—	—
Initial Value	0	0	0	0	0	0	0	0
R/W	R/W	R/W	R/W	R/W	R/W	R/W	R/W	R/W

Bit	Bit Name	Initial Value	R/W	Description
b5 to b0	—	All 0	R/W	Reserved These bits are read as 0. The write value should be 0.
b6	SYNC6	0	R/W	Timer Synchronous Operation 6 0: MTU6.TCNT operates independently (TCNT setting/clearing is not related to other channels). 1: MTU6.TCNT performs synchronous operation. (TCNT synchronous setting/synchronous clearing is enabled.)
b7	SYNC7	0	R/W	Timer Synchronous Operation 7 0: MTU7.TCNT operates independently (TCNT setting/clearing is not related to other channels). 1: MTU7.TCNT performs synchronous operation. (TCNT synchronous setting/synchronous clearing is enabled.)

SYNCn Bits (Timer Synchronous Operation n) (n = 6, 7)

Each bit selects whether operation is independent of or synchronized with other channels.

When synchronous operation is selected, the TCNT synchronous setting of multiple channels and synchronous clearing by counter clearing on another channel are possible.

To set synchronous operation, the SYNC bits for at least two channels must be set to 1. To set synchronous clearing, in addition to the SYNC bit, the TCNT clearing source must also be set by means of bits TCR.CCLR[2:0].

16.2.19 Timer Counter Synchronous Start Register (TCSYSTR)

Address(es): MTU.TCSYSTR H'0_1000_1282

Bit	b7	b6	b5	b4	b3	b2	b1	b0
	SCH0	SCH1	SCH2	SCH3	SCH4	—	SCH6	SCH7
Initial Value	0	0	0	0	0	0	0	0
R/W	R/(W)*1	R/(W)*1	R/(W)*1	R/(W)*1	R/(W)*1	R	R/(W)*1	R/(W)*1

Bit	Bit Name	Initial Value	R/W	Description
b0	SCH7	0	R/(W) *1	Synchronous Start 7 0: Does not specify synchronous start for MTU7.TCNT 1: Specifies synchronous start for MTU7.TCNT
b1	SCH6	0	R/(W) *1	Synchronous Start 6 0: Does not specify synchronous start for MTU6.TCNT 1: Specifies synchronous start for MTU6.TCNT
b2	—	0	R	Reserved This bit is read as 0. The write value should be 0.
b3	SCH4	0	R/(W) *1	Synchronous Start 4 0: Does not specify synchronous start for MTU4.TCNT 1: Specifies synchronous start for MTU4.TCNT
b4	SCH3	0	R/(W) *1	Synchronous Start 3 0: Does not specify synchronous start for MTU3.TCNT 1: Specifies synchronous start for MTU3.TCNT
b5	SCH2	0	R/(W) *1	Synchronous Start 2 0: Does not specify synchronous start for MTU2.TCNT 1: Specifies synchronous start for MTU2.TCNT
b6	SCH1	0	R/(W) *1	Synchronous Start 1 0: Does not specify synchronous start for MTU1.TCNT 1: Specifies synchronous start for MTU1.TCNT
b7	SCH0	0	R/(W) *1	Synchronous Start 0 0: Does not specify synchronous start for MTU0.TCNT 1: Specifies synchronous start for MTU0.TCNT

Note 1. Only 1 can be written to this bit. It is automatically cleared to 0 when counting begins.

TCSYSTR specifies synchronous start of the counters.

SCH7 Bit (Synchronous Start 7)

This bit controls synchronous start of TCNT in MTU7. [Clearing condition]

- When the CST7 bit in TSTRB is set to 1 while SCH7 = 1

SCH6 Bit (Synchronous Start 6)

This bit controls synchronous start of TCNT in MTU6. [Clearing condition]

- When the CST6 bit in TSTRB is set to 1 while SCH6 = 1

SCH4 Bit (Synchronous Start 4)

This bit controls synchronous start of TCNT in MTU4. [Clearing condition]

- When the CST4 bit in TSTRA is set to 1 while SCH4 = 1

SCH3 Bit (Synchronous Start 3)

This bit controls synchronous start of TCNT in MTU3. [Clearing condition]

- When the CST3 bit in TSTRA is set to 1 while SCH3 = 1

SCH2 Bit (Synchronous Start 2)

This bit controls synchronous start of TCNT in MTU2. [Clearing condition]

- When the CST2 bit in TSTRA is set to 1 while SCH2 = 1

SCH1 Bit (Synchronous Start 1)

This bit controls synchronous start of TCNT in MTU1. [Clearing condition]

- When the CST1 bit in TSTRA is set to 1 while SCH1 = 1

SCH0 Bit (Synchronous Start 0)

This bit controls synchronous start of TCNT in MTU0. [Clearing condition]

- When the CST0 bit in TSTRA is set to 1 while SCH0 = 1

16.2.20 Timer Read/Write Enable Registers (TRWERA and TRWERB)

Address(es): MTU.TRWERA H'0_1000_1284, MTU.TRWERB H'0_1000_1A84

Bit	b7	b6	b5	b4	b3	b2	b1	b0
	—	—	—	—	—	—	—	RWE
Initial Value	0	0	0	0	0	0	0	1
R/W	R/W	R/W	R/W	R/W	R/W	R/W	R/W	R/W

Bit	Bit Name	Initial Value	R/W	Description
b0	RWE	1	R/W	Read/Write Enable 0: Read/write access to the registers is disabled 1: Read/write access to the registers is enabled
b7 to b1	—	All 0	R/W	Reserved These bits are read as 0. The write value should be 0.

TRWERA enables or disables access to the registers and counters that have write-protection capability against accidental modification in MTU3 and MTU4.

TRWERB enables or disables access to the registers and counters that have write-protection capability against accidental modification in MTU6 and MTU7.

RWE Bit (Read/Write Enable)

This bit enables or disables access to the registers that have write-protection capability against accidental modification.

[Clearing condition]

When 0 is written to the RWE bit after reading RWE = 1

- Registers and Counters having Write-Protection Capability against Accidental Modification (TRWERA)
24 registers: MTUn.TCR, MTUn.TCR2, MTUn.TMDR1, MTUn.TIORH, MTUn.TIORL, MTUn.TIER, MTUn.TGRA, MTUn.TGRB, TOERA, TOCR1A, TOCR2A, TGCRA, TCDRA, TDDRA, and MTUn.TCNT (n = 3, 4)
- Registers and Counters having Write-Protection Capability against Accidental Modification (TRWERB)
23 registers: MTUn.TCR, MTUn.TCR2, MTUn.TMDR1, MTUn.TIORH, MTUn.TIORL, MTUn.TIER, MTUn.TGRA, MTUn.TGRB, TOERB, TOCR1B, TOCR2B, TCDRB, TDDRB, and MTUn.TCNT (n = 6, 7)

16.2.21 Timer Output Master Enable Registers (TOERA and TOERB)

(1) MTU.TOERA

Address(es): MTU.TOERA H'0_1000_120A

Bit	b7	b6	b5	b4	b3	b2	b1	b0
	—	—	OE4D	OE4C	OE3D	OE4B	OE4A	OE3B
Initial Value	1	1	0	0	0	0	0	0
	R/W	R/W	R/W	R/W	R/W	R/W	R/W	R/W

Bit	Bit Name	Initial Value	R/W	Description
b0	OE3B	0	R/W	Master Enable MTIOC3B 0: MTU output is disabled*1 1: MTU output is enabled
b1	OE4A	0	R/W	Master Enable MTIOC4A 0: MTU output is disabled*1 1: MTU output is enabled
b2	OE4B	0	R/W	Master Enable MTIOC4B 0: MTU output is disabled*1 1: MTU output is enabled
b3	OE3D	0	R/W	Master Enable MTIOC3D 0: MTU output is disabled*1 1: MTU output is enabled
b4	OE4C	0	R/W	Master Enable MTIOC4C 0: MTU output is disabled*1 1: MTU output is enabled
b5	OE4D	0	R/W	Master Enable MTIOC4D 0: MTU output is disabled*1 1: MTU output is enabled
b7, b6	—	All 1	R/W	Reserved These bits are read as 1. The write value should be 1.

Note 1. To output the inactive level from each pin when the MTU output is set to disabled, first set the port mode register (PMn) and port register (Pn) of I/O ports to output the inactive level from general I/O ports, and then set the port mode control register (PMCn) to use general I/O ports. For details, refer to **Section 41, General Purpose Input Output Port**.

TOERA enables or disables output settings for output pins MTIOC4D, MTIOC4C, MTIOC3D, MTIOC4B, MTIOC4A, and MTIOC3B.

These pins do not output values correctly if the bits of the TOERA register are not appropriately set. Write a desired value to the TOERA register before setting up the TIOR registers in MTU3 and MTU4.

Set the TOERA register after clearing the CST3 and CST4 bits in the TSTRA register to 0 (see **Figure 16.44** and **Figure 16.48**).

(2) MTU.TOERB

Address(es): MTU.TOERB H'0_1000_1A0A

Bit	b7	b6	b5	b4	b3	b2	b1	b0
	—	—	OE7D	OE7C	OE6D	OE7B	OE7A	OE6B
Initial Value	1	1	0	0	0	0	0	0
R/W	R/W	R/W	R/W	R/W	R/W	R/W	R/W	R/W

Bit	Bit Name	Initial Value	R/W	Description
b0	OE6B	0	R/W	Master Enable MTIOC6B 0: MTU output is disabled*1 1: MTU output is enabled
b1	OE7A	0	R/W	Master Enable MTIOC7A 0: MTU output is disabled*1 1: MTU output is enabled
b2	OE7B	0	R/W	Master Enable MTIOC7B 0: MTU output is disabled*1 1: MTU output is enabled
b3	OE6D	0	R/W	Master Enable MTIOC6D 0: MTU output is disabled*1 1: MTU output is enabled
b4	OE7C	0	R/W	Master Enable MTIOC7C 0: MTU output is disabled*1 1: MTU output is enabled
b5	OE7D	0	R/W	Master Enable MTIOC7D 0: MTU output is disabled*1 1: MTU output is enabled
b7, b6	—	All 1	R/W	Reserved These bits are read as 1. The write value should be 1.

Note 1. To output the inactive level from each pin when the MTU output is set to disabled, first set the port mode register (PMn) and port register (Pn) of I/O ports to output the inactive level from general I/O ports, and then set the port mode control register (PMCn) to use general I/O ports. For details, refer to **Section 41, General Purpose Input Output Port**.

TOERB enables or disables output settings for output pins MTIOC7D, MTIOC7C, MTIOC6D, MTIOC7B, MTIOC7A, and MTIOC6B.

These pins do not output values correctly if the bits of the TOERB register are not appropriately set. Write a desired value to the TOERB register before setting up the TIOR registers in MTU6 and MTU7.

Set the TOERB register after clearing the CST6 and CST7 bits in the TSTRB register to 0 (see **Figure 16.44** and **Figure 16.48**).

16.2.22 Timer Output Control Registers 1 (TOCR1A and TOCR1B)

Address(es): MTU.TOCR1A H'0_1000_120E, MTU.TOCR1B H'0_1000_1A0E

Bit	b7	b6	b5	b4	b3	b2	b1	b0
	—	PSYE	—	—	TOCL	TOCS	OLSN	OLSP
Initial Value	0	0	0	0	0	0	0	0
R/W	R/W	R/W	R/W	R/W	R/W	R/W	R/W	R/W

Bit	Bit Name	Initial Value	R/W	Description
b0	OLSP	0	R/W	Output Level Select P*1 *3 See Table 16.43 .
b1	OLSN	0	R/W	Output Level Select N*1 *3 See Table 16.44 .
b2	TOCS	0	R/W	TOC Select 0: TOCR1j setting is selected (j = A, B) 1: TOCR2j setting is selected
b3	TOCL	0	R/W	TOC Register Write Protection*2 *4 0: Write access to the TOCS, OLSN, and OLSP bits is enabled 1: Write access to the TOCS, OLSN, and OLSP bits is disabled
b5, b4	—	All 0	R/W	Reserved These bits are read as 0. The write value should be 0.
b6	PSYE	0	R/W	PWM Synchronous Output Enable 0: Toggle output is disabled 1: Toggle output is enabled
b7	—	0	R/W	Reserved This bit is read as 0. The write value should be 0.

Note 1. Clearing the TOCR1j.TOCS bit to 0 makes this bit setting valid.

Note 2. Setting the TOCR1j.TOCL bit to 1 prevents accidental modification when the CPU goes out of control.

Note 3. If dead-time is not generated, the negative-phase output is the exact inverse of the positive-phase output. In this case, only the OLSP bit is valid.

Note 4. This bit can be set to 1 only once after a reset. After 1 is written, 0 cannot be written to the bit.

TOCR1A and TOCR1B enable or disable PWM-synchronized toggle output in complementary PWM mode and reset-synchronized PWM mode, and control inversion of PWM output level.

OLSP Bit (Output Level Select P)

This bit selects the positive-phase output level in reset-synchronized PWM mode and complementary PWM mode. The initial output is selected while the counter is stopped.

OLSN Bit (Output Level Select N)

This bit selects the negative-phase output level in reset-synchronized PWM mode and complementary PWM mode. The initial output is selected while the counter is stopped.

TOCS Bit (TOC Select)

This bit selects either the TOCR1j or TOCR2j (j = A, B) setting to be used for the output level in complementary PWM mode and reset-synchronized PWM mode.

TOCL Bit (TOC Register Write Protection)

This bit enables or disables write access to the TOCS, OLSN, and OLSP bits in TOCR1j (j = A, B).

PSYE Bit (PWM Synchronous Output Enable)

This bit enables or disables toggle output synchronized with the PWM cycle.

Table 16.43 Output Level Select Function

Bit 0	Function				
OLSP	Initial Output	Active Level	Compare Match Output		
			Up-Counting	Down-Counting	
0	High level	Low level	Low level	High level	
1	Low level	High level	High level	Low level	

Table 16.44 Output Level Select Function

Bit 1	Function				
OLSN	Initial Output	Active Level	Compare Match Output		
			Up-Counting	Down-Counting	
0	High level	Low level	High level	Low level	
1	Low level	High level	Low level	High level	

Note: The initial output value of negative-phase waveform changes to an active level after the dead time has passed since counting starts.

Figure 16.3 shows an example of output in complementary PWM mode (one phase) when OLSN = 1 and OLSP = 1.

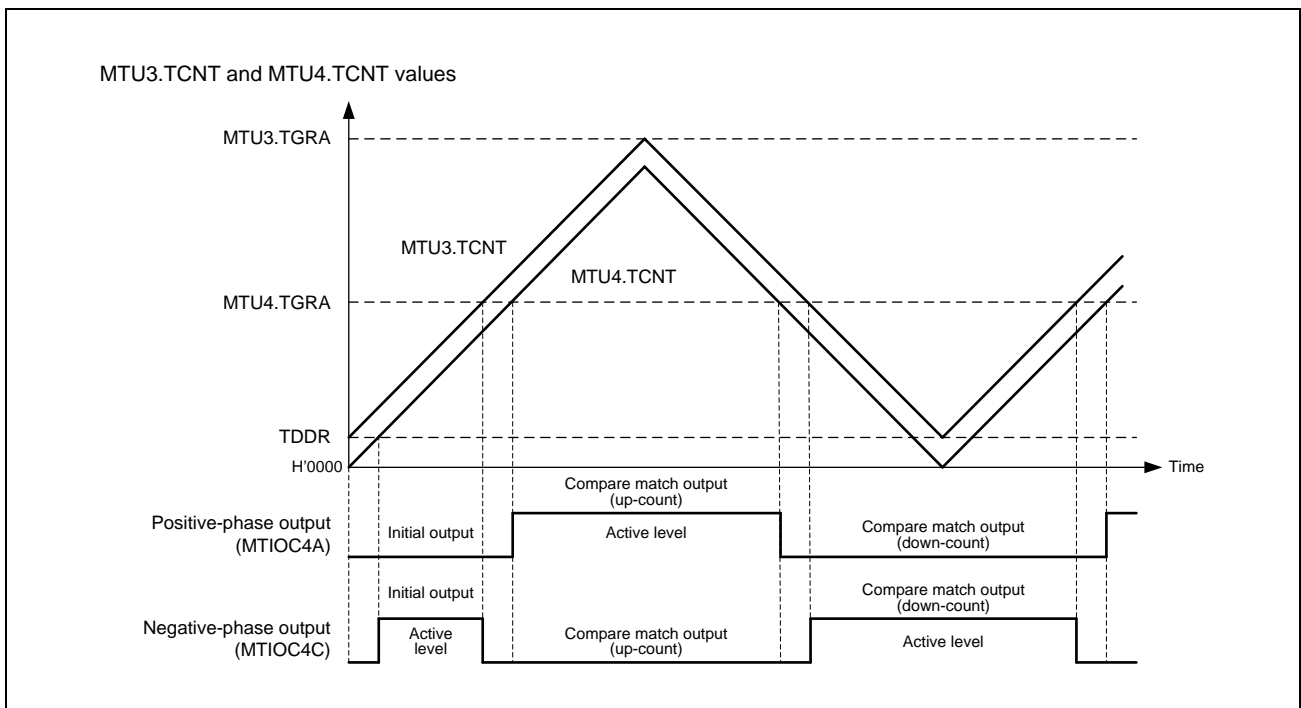

Figure 16.3 Example of Output in Complementary PWM Mode

16.2.23 Timer Output Control Registers 2 (TOCR2A and TOCR2B)

Address(es): MTU.TOCR2A H'0_1000_120F, MTU.TOCR2B H'0_1000_1A0F

Bit	b7	b6	b5	b4	b3	b2	b1	b0
	BF[1:0]		OLS3N	OLS3P	OLS2N	OLS2P	OLS1N	OLS1P
Initial Value	0	0	0	0	0	0	0	0
R/W	R/W	R/W	R/W	R/W	R/W	R/W	R/W	R/W

Bit	Bit Name	Initial Value	R/W	Description
b0	OLS1P	0	R/W	Output Level Select 1P*1 *2 This bit selects the output level on MTIOC3B or MTIOC6B in reset-synchronized PWM mode and complementary PWM mode. See Table 16.45 .
b1	OLS1N	0	R/W	Output Level Select 1N*1 *2 This bit selects the output level on MTIOC3D or MTIOC6D in reset-synchronized PWM mode and complementary PWM mode. See Table 16.46 .
b2	OLS2P	0	R/W	Output Level Select 2P*1 *2 This bit selects the output level on MTIOC4A or MTIOC7A in reset-synchronized PWM mode and complementary PWM mode. See Table 16.47 .
b3	OLS2N	0	R/W	Output Level Select 2N*1 *2 This bit selects the output level on MTIOC4C or MTIOC7C in reset-synchronized PWM mode and complementary PWM mode. See Table 16.48 .
b4	OLS3P	0	R/W	Output Level Select 3P*1 *2 This bit selects the output level on MTIOC4B or MTIOC7B in reset-synchronized PWM mode and complementary PWM mode. See Table 16.49 .
b5	OLS3N	0	R/W	Output Level Select 3N*1 *2 This bit selects the output level on MTIOC4D or MTIOC7D in reset-synchronized PWM mode and complementary PWM mode. See Table 16.50 .
b7, b6	BF[1:0]	All 0	R/W	TOLBR Buffer Transfer Timing Select These bits select the timing for transferring data from TOLBRj to TOCR2j. See Table 16.51 for details.

Note: j = A, B

Note 1. Setting the TOCR1j.TOCS bit to 1 makes this bit setting valid.

Note 2. If dead-time is not generated, the negative-phase output is the exact inverse of the positive-phase output. In this case, only the OLSiP bits are valid (i = 1 to 3).

TOCR2A and TOCR2B control inversion of PWM output level in complementary PWM mode and reset-synchronized PWM mode.

The initial output is selected while the counter is stopped.

Table 16.45 MTIOcM_B Output Level Select Function

Bit 0	Function			
OLS1P	Initial Output	Active Level	Compare Match Output	
			Up-Counting	Down-Counting
0	High level	Low level	Low level	High level
1	Low level	High level	High level	Low level

Note: m = 3, 6

Table 16.46 MTIOcM_D Output Level Select Function

Bit 1	Function			
OLS1N	Initial Output	Active Level	Compare Match Output	
			Up-Counting	Down-Counting
0	High level	Low level	High level	Low level
1	Low level	High level	Low level	High level

Note: m = 3, 6

Note: The initial output value of negative-phase waveform changes to an active level after the dead time has passed since counting starts.

Table 16.47 MTIOcM_A Output Level Select Function

Bit 2	Function			
OLS2P	Initial Output	Active Level	Compare Match Output	
			Up-Counting	Down-Counting
0	High level	Low level	Low level	High level
1	Low level	High level	High level	Low level

Note: m = 4, 7

Table 16.48 MTIOcM_C Output Level Select Function

Bit 3	Function			
OLS2N	Initial Output	Active Level	Compare Match Output	
			Up-Counting	Down-Counting
0	High level	Low level	High level	Low level
1	Low level	High level	Low level	High level

Note: m = 4, 7

Note: The initial output value of negative-phase waveform changes to an active level after the dead time has passed since counting starts.

Table 16.49 MTIOcM_B Output Level Select Function

Bit 4	Function			
OLS3P	Initial Output	Active Level	Compare Match Output	
			Up-Counting	Down-Counting
0	High level	Low level	Low level	High level
1	Low level	High level	High level	Low level

Note: m = 4, 7

Table 16.50 MTIOCmD Output Level Select Function

Bit 5	Function			
OLS3N	Initial Output	Active Level	Compare Match Output	
			Up-Counting	Down-Counting
0	High level	Low level	High level	Low level
1	Low level	High level	Low level	High level

Note: m = 4, 7

Note: The initial output value of negative-phase waveform changes to an active level after the dead time has passed since counting starts.

Table 16.51 Setting of TOCR2j.BF[1:0] Bits

Bit 7	Bit 6	Description	
BF1	BF0	Complementary PWM Mode	Reset-Synchronized PWM Mode
0	0	Does not transfer data from the buffer register (TOLBRj) to TOCR2j.	Does not transfer data from the buffer register (TOLBRj) to TOCR2j.
	1	Transfers data from the buffer register (TOLBRj) to TOCR2j at the crest of the MTUn.TCNT count.	Transfers data from the buffer register (TOLBRj) to TOCR2j when MTUm.TCNT or MTUn.TCNT is cleared.
1	0	Transfers data from the buffer register (TOLBRj) to TOCR2j at the trough of the MTUn.TCNT count.	Setting prohibited
	1	Transfers data from the buffer register (TOLBRj) to TOCR2j at the crest and trough of the MTUn.TCNT count.	Setting prohibited

Note: n = 4, 7;
m = 3, 6;
j = A, B

16.2.24 Timer Output Level Buffer Registers (TOLBRA and TOLBRB)

Address(es): MTU.TOLBRA H'0_1000_1236, MTU.TOLBRB H'0_1000_1A36

Bit	b7	b6	b5	b4	b3	b2	b1	b0
	—	—	OLS3N	OLS3P	OLS2N	OLS2P	OLS1N	OLS1P
Initial Value	0	0	0	0	0	0	0	0
R/W	R/W	R/W	R/W	R/W	R/W	R/W	R/W	R/W

Bit	Bit Name	Initial Value	R/W	Description
b0	OLS1P	0	R/W	Output Level Select 1P Specify the buffer value to be transferred to the OLS1P bit in TOCR2j.
b1	OLS1N	0	R/W	Output Level Select 1N Specify the buffer value to be transferred to the OLS1N bit in TOCR2j.
b2	OLS2P	0	R/W	Output Level Select 2P Specify the buffer value to be transferred to the OLS2P bit in TOCR2j.
b3	OLS2N	0	R/W	Output Level Select 2N Specify the buffer value to be transferred to the OLS2N bit in TOCR2j.
b4	OLS3P	0	R/W	Output Level Select 3P Specify the buffer value to be transferred to the OLS3P bit in TOCR2j.
b5	OLS3N	0	R/W	Output Level Select 3N Specify the buffer value to be transferred to the OLS3N bit in TOCR2j.
b7, b6	—	All 0	R/W	Reserved These bits are read as 0. The write value should be 0.

Note: j = A, B

TOLBRA and TOLBRB are buffer registers for TOCR2A and TOCR2B and specify the PWM output level in complementary PWM mode and reset-synchronized PWM mode.

Figure 16.4 shows an example of the PWM output level setting procedure in buffer operation.

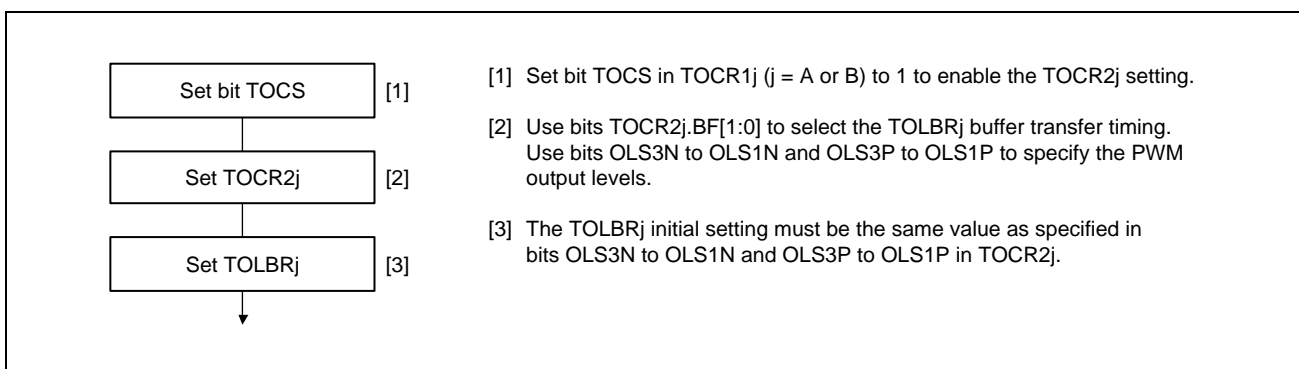

Figure 16.4 Example of PWM Output Level Setting Procedure in Buffer Operation

16.2.25 Timer Gate Control Register A (TGCRA)

Address(es): MTU.TGCRA H'0_1000_120D

Bit	b7	b6	b5	b4	b3	b2	b1	b0
	—	BDC	N	P	FB	WF	VF	UF
Initial Value	1	0	0	0	0	0	0	0
R/W	R/W	R/W	R/W	R/W	R/W	R/W	R/W	R/W

Bit	Bit Name	Initial Value	R/W	Description
b0	UF	0	R/W	Output Phase Switch
b1	VF	0	R/W	These bits turn on or off the positive-phase/negative-phase output. The setting of these bits is valid only when the FB bit is set to 1. In this case, the setting of b0 to b2 is used instead of the external input. See Table 16.52 .
b2	WF	0	R/W	
b3	FB	0	R/W	
b4	P	0	R/W	Positive-Phase Output (P) Control 0: Level output 1: Reset-synchronized PWM or complementary PWM output
b5	N	0	R/W	Negative-Phase Output (N) Control 0: Level output 1: Reset-synchronized PWM or complementary PWM output
b6	BDC	0	R/W	Brushless DC Motor 0: Ordinary output 1: Functions of this register are effective.
b7	—	1	R/W	Reserved This bit is read as 1. The write value should be 1.

TGCRA controls the output waveform necessary for brushless DC motor control in reset-synchronized PWM mode and complementary PWM mode. TGCRA register settings are ineffective for anything other than complementary PWM mode and reset-synchronized PWM mode.

UF, VF, and WF Bits (Output Phase Switch)

The setting of these bits is valid only when the FB bit is set to 1. In this case, the setting of b0 to b2 is used instead of the external input. See **Table 16.52** for details.

FB Bit (External Feedback Signal Enable)

This bit selects whether the positive-/negative-phase output is switched automatically with the TGRA, TGRB, and TGRC input capture signals in MTU0 or by writing 0 or 1 to bits 2 to 0 in TGCRA.

When the FB bit in the TGCRA register is 0, the output signals from MTU3 and MTU4 are switched automatically with the TGRA, TGRB, and TGRC input capture signals in MTU0.

P Bit (Positive-Phase Output (P) Control)

This bit selects either the level output or the reset-synchronized PWM/complementary PWM output for the positive-phase output pins (MTIOC3B, MTIOC4A, and MTIOC4B pins).

N Bit (Negative-Phase Output (N) Control)

This bit selects the level output or the reset-synchronized PWM/complementary PWM output for the negative-phase output pins (MTIOC3D, MTIOC4C, and MTIOC4D pins).

BDC Bit (Brushless DC Motor)

This bit selects whether to make the functions of TGCRA effective or ineffective.

Table 16.52 Output Level Select Function

Bit 2	Bit 1	Bit 0	Function					
			MTIOC3B	MTIOC4A	MTIOC4B	MTIOC3D	MTIOC4C	MTIOC4D
WF	VF	UF	U Phase	V Phase	W Phase	U Phase	V Phase	W Phase
0	0	0	OFF	OFF	OFF	OFF	OFF	OFF
		1	ON	OFF	OFF	OFF	OFF	ON
	1	0	OFF	ON	OFF	ON	OFF	OFF
		1	OFF	ON	OFF	OFF	OFF	ON
1	0	0	OFF	OFF	ON	OFF	ON	OFF
		1	ON	OFF	OFF	OFF	ON	OFF
	1	0	OFF	OFF	ON	ON	OFF	OFF
		1	OFF	OFF	OFF	OFF	OFF	OFF

16.2.26 Timer Subcounters (TCNTSA and TCNTSB)

Address(es): MTU.TCNTSA H'0_1000_1220, MTU.TCNTSB H'0_1000_1A20

Bit	b15	b14	b13	b12	b11	b10	b9	b8	b7	b6	b5	b4	b3	b2	b1	b0
Initial Value	0	0	0	0	0	0	0	0	0	0	0	0	0	0	0	0
R/W	R	R	R	R	R	R	R	R	R	R	R	R	R	R	R	R

Note: TCNTSA and TCNTSB must not be accessed in eight bits; it should be accessed in 16 bits.

TCNTSA and TCNTSB are 16-bit read-only counters that are used only in complementary PWM mode. The initial value of TCNTSA and TCNTSB after a reset is H'0000.

16.2.27 Timer Cycle Data Registers (TCDRA and TCDRB)

Address(es): MTU.TCDRA H'0_1000_1214, MTU.TCDRB H'0_1000_1A14

Bit	b15	b14	b13	b12	b11	b10	b9	b8	b7	b6	b5	b4	b3	b2	b1	b0
Initial Value	1	1	1	1	1	1	1	1	1	1	1	1	1	1	1	1
R/W	R/W	R/W	R/W	R/W	R/W	R/W	R/W	R/W	R/W	R/W	R/W	R/W	R/W	R/W	R/W	R/W

Note: TCDRA and TCDRB must not be accessed in eight bits; it should be accessed in 16 bits.

TCDRA and TCDRB are 16-bit readable/writable registers used only in complementary PWM mode. Set half the PWM carrier cycle as the TCDRA and TCDRB values. The TCDRA and TCDRB registers are constantly compared with the TCNTSA and TCNTSB counters in complementary PWM mode, respectively. When a match occurs, the TCNTSA and TCNTSB counters switch the count direction (down-count to up-count). The initial value of TCDRA and TCDRB after a reset is H'FFFF.

16.2.28 Timer Cycle Buffer Registers (TCBRA and TCBRB)

Address(es): MTU.TCBRA H'0_1000_1222, MTU.TCBRB H'0_1000_1A22

Bit	b15	b14	b13	b12	b11	b10	b9	b8	b7	b6	b5	b4	b3	b2	b1	b0
Initial Value	1	1	1	1	1	1	1	1	1	1	1	1	1	1	1	1
	R/W	R/W	R/W	R/W	R/W	R/W	R/W	R/W	R/W	R/W	R/W	R/W	R/W	R/W	R/W	R/W

Note: TCBRA and TCBRB must not be accessed in eight bits; it should be accessed in 16 bits.

TCBRA and TCBRB are 16-bit readable/writable registers, used only in complementary PWM mode, that function as buffer registers for TCDRA and TCDRB. The TCBRA and TCBRB values are transferred to TCDRA and TCDRB with the transfer timing set in TMDR1. The initial value of TCBRA and TCBRB after a reset is H'FFFF.

16.2.29 Timer Dead Time Data Registers (TDDRA and TDDRb)

Address(es): MTU.TDDRA H'0_1000_1216, MTU.TDDRb H'0_1000_1A16

Bit	b15	b14	b13	b12	b11	b10	b9	b8	b7	b6	b5	b4	b3	b2	b1	b0
Initial Value	1	1	1	1	1	1	1	1	1	1	1	1	1	1	1	1
	R/W	R/W	R/W	R/W	R/W	R/W	R/W	R/W	R/W	R/W	R/W	R/W	R/W	R/W	R/W	R/W

Note: TDDRA and TDDRb must not be accessed in eight bits; it should be accessed in 16 bits.

TDDRA and TDDRb are 16-bit readable/writable registers, used only in complementary PWM mode, that specify the MTU3.TCNT (MTU6.TCNT) and MTU4.TCNT (MTU7.TCNT) counter offset value. In complementary PWM mode, when the MTU3.TCNT (MTU6.TCNT) and MTU4.TCNT (MTU7.TCNT) counters are cleared and then restarted, the TDDRA (TDDRb) value is loaded into the MTU3.TCNT (MTU6.TCNT) counter and the count operation starts. The initial value of TDDRA and TDDRb after a reset is H'FFFF.

16.2.30 Timer Dead Time Enable Registers (TDERA and TDERB)

Address(es): MTU.TDERA H'0_1000_1234, MTU.TDERB H'0_1000_1A34

Bit	b7	b6	b5	b4	b3	b2	b1	b0
	—	—	—	—	—	—	—	TDER
Initial Value	0	0	0	0	0	0	0	1
R/W	R/W	R/W	R/W	R/W	R/W	R/W	R/W	R/(W)

Bit	Bit Name	Initial Value	R/W	Description
b0	TDER	1	R/(W)	Dead Time Enable 0: No dead time is generated 1: Dead time is generated*1
b7 to b1	—	All 0	R/W	Reserved These bits are read as 0. The write value should be 0.

Note 1. TDDRA and TDDRB must be set to 1 or a larger value.

TDERA and TDERB control dead time generation in complementary PWM mode. The MTU has one TDER each for MTU3 and MTU6. TDERA and TDERB should be modified only while TCNT stops.

TDER Bit (Dead Time Enable)

This bit specifies whether to generate dead time.

[Clearing condition]

- When 0 is written to TDER after reading TDER = 1

16.2.31 Timer Buffer Transfer Set Registers (TBTERA and TBTERB)

Address(es): MTU.TBTERA H'0_1000_1232, MTU.TBTERB H'0_1000_1A32

Bit	b7	b6	b5	b4	b3	b2	b1	b0
	—	—	—	—	—	—	BTE[1:0]	
Initial Value	0	0	0	0	0	0	0	0
R/W	R/W	R/W	R/W	R/W	R/W	R/W	R/W	R/W

Bit	Bit Name	Initial Value	R/W	Description
b1, b0	BTE[1:0]	All 0	R/W	Buffer Transfer Disable and Interrupt Skipping Link Setting These bits enable or disable transfer from the buffer registers* ¹ used in complementary PWM mode to the temporary registers, and specify whether to link the transfer with interrupt skipping function 1. For details, see Table 16.53 .
b7 to b2	—	All 0	R/W	Reserved These bits are read as 0. The write value should be 0.

Note 1. Applicable buffer registers (TBTERA):
MTU3.TGRC, MTU3.TGRD, MTU4.TGRC, MTU4.TGRD, and TCBRA
Applicable buffer registers (TBTERB):
MTU6.TGRC, MTU6.TGRD, MTU7.TGRC, MTU7.TGRD, and TCBRB

TBTERA and TBTERB enable or disable transfer from the buffer registers used in complementary PWM mode to the temporary registers, and specify whether to link the transfer with interrupt skipping 1 operation.

Table 16.53 Setting of BTE[1:0] Bits in TBTERA and TBTERB

Bit 1	Bit 0	Description
BTE1	BTE0	Description
0	0	Enables transfer from the buffer registers to the temporary registers* ¹ and does not link the transfer with interrupt skipping function 1.
	1	Disables transfer from the buffer registers to the temporary registers.
1	0	Links transfer from the buffer registers to the temporary registers with interrupt skipping function 1.* ²
	1	Setting prohibited

Note 1. Data is transferred according to the MD3 to MD0 bit setting in TMDR1. For details, refer to **Section 16.3.8, Complementary PWM Mode**.

Note 2. When interrupt skipping is disabled (the T3AEN and T4VEN (T6AEN and T7VEN) bits are cleared to 0 in the timer interrupt skipping set register (TITCR1A (TITCR1B)) or the skipping count set bits (T3ACOR and T4VCOR (T6ACOR and T7VCOR)) in TITCR1A (TITCR1B) are cleared to 0), be sure to disable link of buffer transfer with interrupt skipping (clear the BTE1 bit in the timer buffer transfer set register (TBTERA (TBTERB)) to 0). If link with interrupt skipping is enabled while interrupt skipping is disabled, buffer transfer will not be performed.

16.2.32 Timer Waveform Control Registers (TWCRA and TWCRB)

Address(es): MTU.TWCRA H'0_1000_1260, MTU.TWCRB H'0_1000_1A60

Bit	b7	b6	b5	b4	b3	b2	b1	b0
	CCE	—	—	—	—	—	SCC	WRE
Initial Value	0*2	0	0	0	0	0	0	0
R/W	R/(W)	R/W	R/W	R/W	R/W	R/W	R/(W)	R/(W)*3

Bit	Bit Name	Initial Value	R/W	Description
b0	WRE	0	R/(W) *3	Waveform Retain Enable 0: Initial values specified in TOCR1A and TOCR2A (TOCR1B and TOCR2B) are output 1: Initial output is inhibited
b1	SCC*1*3	0	R/(W)	Synchronous Clearing Control (Only valid in register TWCRB) 0: Clearing of MTU6.TCNT and MTU7.TCNT in response to synchronous clearing for MTU0, MTU1, MTU2–MTU6, MTU7 is enabled. 1: Clearing of MTU6.TCNT and MTU7.TCNT in response to synchronous clearing for MTU0, MTU1, MTU2–MTU6, MTU7 is disabled.
b6 to b2	—	All 0	R/W	Reserved These bits are read as 0. The write value should be 0.
b7	CCE*2	0	R/(W)	Compare Match Clear Enable 0: Counters are not cleared at MTU3.TGRA (MTU6.TGRA) compare match 1: Counters are cleared at MTU3.TGRA (MTU6.TGRA) compare match

Note 1. This bit is only valid in register TWCRB and is a reserved bit in register TWCRA.

Note 2. Do not set to 1 when complementary PWM mode 1 is not selected.

Note 3. Do not set to 1 when complementary PWM mode is not selected.

TWCRA and TWCRB control the output waveform when synchronous counter clearing occurs in MTU3.TNCT and MTU4.TNCT (MTU6.TNCT and MTU7.TNCT) in complementary PWM mode and specifies whether to clear the counters at MTU3.TGRA (MTU6.TGRA) compare match.

The CCE bit and WRE bit in TWCRA and TWCRB should be modified only while TCNT stops.

WRE Bit (Waveform Retain Enable)

This bit selects the waveform output when synchronous counter clearing occurs in complementary PWM mode. The initial output is inhibited with this function only when synchronous clearing occurs within the T_b interval at the trough in complementary PWM mode. When synchronous clearing occurs outside this interval, the initial values specified in TOCR1A and TOCR2A (TOCR1B and TOCR2B) are output regardless of the WRE bit setting. The initial values specified in TOCR1A and TOCR2A (TOCR1B and TOCR2B) are also output when synchronous clearing occurs in the T_b interval at the trough immediately after MTU3.TCNT and MTU4.TCNT (MTU6.TCNT and MTU7.TCNT) start operation.

For the T_b interval at the trough in complementary PWM mode, see **Figure 16.50**.

[Setting condition]

- When 1 is written to the WRE bit after reading WRE = 0

SCC Bit (Synchronous Clearing Control)

The setting of this bit selects whether MTU6.TCNT and MTU7.TCNT are or are not cleared when counter-synchronous clearing is generated for MTU0, MTU1, MTU2–MTU6, MTU7 in complementary PWM mode.

Make the complementary PWM mode settings for MTU6 and MTU7 when this function is in use. When writing a new value to the SCC bit while the counter is operating, do not change the values of the CCE and WRE bits.

Synchronous clearing from the MTU module only becomes disabled due to the setting of the SCC bit when synchronous clearing is generated outside the Tb interval in the trough. If synchronous clearing is generated within the Tb interval in the trough including immediately after the value at which MTU6.TCNT and MTU7.TCNT start, MTU6.TCNT and MTU7.TCNT are cleared.

Regarding the Tb interval in the trough in complementary PWM mode, see **Figure 16.50**.

[Setting condition]

- Writing of 1 to the SCC bit after reading it as 0

The corresponding bit in register TWCRA is reserved and is read as 0. When writing to TWCRA, write 0 to this bit.

CCE Bit (Compare Match Clear Enable)

This bit specifies whether to clear counters at MTU3.TGRA (MTU6.TGRA) compare match in complementary PWM mode.

[Setting condition]

When 1 is written to CCE after reading CCE = 0

16.2.33 Noise Filter Control Register n (NFCRn) (n = 0 to 4, 6, 7, 8, C)

(1) MTU0.NFCR0, MTU1.NFCR1, MTU2.NFCR2, MTU3.NFCR3, MTU4.NFCR4, MTU6.NFCR6, MTU7.NFCR7, MTU8.NFCR8

Address(es): MTU0.NFCR0 H'0_1000_1290, MTU1.NFCR1 H'0_1000_1291, MTU2.NFCR2 H'0_1000_1292, MTU3.NFCR3 H'0_1000_1293, MTU4.NFCR4 H'0_1000_1294, MTU6.NFCR6 H'0_1000_1A93, MTU7.NFCR7 H'0_1000_1A94, MTU8.NFCR8 H'0_1000_1298

Bit	b7	b6	b5	b4	b3	b2	b1	b0
	—	—	NFCS[1:0]	NFDEN	NFCEN	NFBEN	NFAEN	
Initial Value	0	0	0	0	0	0	0	0
	R/W	R/W	R/W	R/W	R/W*1	R/W*1	R/W	R/W

Bit	Bit Name	Initial Value	R/W	Description
b0	NFAEN	0	R/W	Noise Filter A Enable 0: The noise filter for the MTIOCnA pin is disabled. 1: The noise filter for the MTIOCnA pin is enabled.
b1	NFBEN	0	R/W	Noise Filter B Enable 0: The noise filter for the MTIOCnB pin is disabled. 1: The noise filter for the MTIOCnB pin is enabled.
b2	NFCEN	0	R/W*1	Noise Filter C Enable 0: The noise filter for the MTIOCnC pin is disabled. 1: The noise filter for the MTIOCnC pin is enabled.
b3	NFDEN	0	R/W*1	Noise Filter D Enable 0: The noise filter for the MTIOCnD pin is disabled. 1: The noise filter for the MTIOCnD pin is enabled.
b5, b4	NFCS[1:0]	All 0	R/W	Noise Filter Clock Select b5 b4 0 0: P0φ/1 0 1: P0φ/8 1 0: P0φ/32 1 1: Clock source for counting
b7, b6	—	All 0	R/W	Reserved These bits are read as 0. The write value should be 0.

Note 1. These bits are reserved in the NFCR1 and NFCR2 registers. These bits are read as 0 and writing to them has no effect.

The NFCRn register (n = 0 to 4, 6, 7, or 8) specifies the noise filter function of the input capture input pin of the corresponding channel.

NFAEN Bit (Noise Filter A Enable)

This bit disables or enables the noise filter for input from the MTIOCnA pin. Since changing the value of the bit may lead to the internal generation of an unexpected edge, select the output compare function for the relevant pin in the timer I/O control register or set the TMDR.MD[3:0] bits to a value other than that for normal mode (0000b) before doing so.

NFBEN Bit (Noise Filter B Enable)

This bit disables or enables the noise filter for input from the MTIOcNB pin. Since changing the value of the bit may lead to the internal generation of an unexpected edge, select the output compare function for the relevant pin in the timer I/O control register or set the TMDR.MD[3:0] bits to a value other than that for normal mode (0000b) before doing so.

NFCEN Bit (Noise Filter C Enable)

This bit disables or enables the noise filter for input from the MTIOcNC pin. Since changing the value of the bit may lead to the internal generation of an unexpected edge, select the output compare function for the relevant pin in the timer I/O control register or set the TMDR.MD[3:0] bits to a value other than that for normal mode (0000b) before doing so.

NFDEN Bit (Noise Filter D Enable)

This bit disables or enables the noise filter for input from the MTIOcND pin. Since changing the value of the bit may lead to the internal generation of an unexpected edge, select the output compare function for the relevant pin in the timer I/O control register or set the TMDR.MD[3:0] bits to a value other than that for normal mode (0000b) before doing so.

NFCS[1:0] Bits (Noise Filter Clock Select)

These bits set the sampling interval for the noise filters. When setting the NFCS[1:0] bits, wait for two cycles of the selected sampling interval before setting the input-capture function. When the NFCS[1:0] bits are set to 11b, i.e. selecting the external clock as the source to drive counting, wait for two cycles of the external clock before setting the input capture function.

(2) MTU0.NFCRC

Address(es): MTU0.NFCRC H'0_1000_1299

Bit	b7	b6	b5	b4	b3	b2	b1	b0
	—	—	NFCS[1:0]	NFDEN	NFCEN	NFBEN	NFAEN	
Initial Value	0	0	0	0	0	0	0	0
R/W	R/W	R/W	R/W	R/W	R/W	R/W	R/W	R/W

Bit	Bit Name	Initial Value	R/W	Description
b0	NFAEN	0	R/W	Noise Filter A Enable 0: The noise filter for the MTCLKA pin is disabled. 1: The noise filter for the MTCLKA pin is enabled.
b1	NFBEN	0	R/W	Noise Filter B Enable 0: The noise filter for the MTCLKB pin is disabled. 1: The noise filter for the MTCLKB pin is enabled.
b2	NFCEN	0	R/W	Noise Filter C Enable 0: The noise filter for the MTCLKC pin is disabled. 1: The noise filter for the MTCLKC pin is enabled.
b3	NFDEN	0	R/W	Noise Filter D Enable 0: The noise filter for the MTCLKD pin is disabled. 1: The noise filter for the MTCLKD pin is enabled.
b5, b4	NFCS[1:0]	All 0	R/W	Noise Filter Clock Select b5 b4 0 0: P0φ/1 0 1: P0φ/2 1 0: P0φ/8 1 1: P0φ/32
b7, b6	—	All 0	R/W	Reserved These bits are read as 0. The write value should be 0.

The NFCRC register is used in common with all channels and specifies the noise filter function of the external clock pins.

NFAEN Bit (Noise Filter A Enable)

This bit disables or enables the noise filter for input from the MTCLKA pin. Since changing the value of the bit may lead to the internal generation of an unexpected edge, do so after stopping the internal counter.

NFBEN Bit (Noise Filter B Enable)

This bit disables or enables the noise filter for input from the MTCLKB pin. Since changing the value of the bit may lead to the internal generation of an unexpected edge, do so after stopping the internal counter.

NFCEN Bit (Noise Filter C Enable)

This bit disables or enables the noise filter for input from the MTCLKC pin. Since changing the value of the bit may lead to the internal generation of an unexpected edge, do so after stopping the internal counter.

NFDEN Bit (Noise Filter D Enable)

This bit disables or enables the noise filter for input from the MTCLKD pin. Since changing the value of the bit may lead to the internal generation of an unexpected edge, do so after stopping the internal counter.

NFCS[1:0] Bits (Noise Filter Clock Select)

These bits set the sampling interval for the noise filters. After setting the NFCS[1:0] bits, wait for two cycles of the selected sampling interval to set the input capture function.

16.2.34 Noise Filter Control Register 5 (NFCR5)

Address(es): MTU5.NFCR5 H'0_1000_1A95

Bit	b7	b6	b5	b4	b3	b2	b1	b0
	—	—	NFCS[1:0]	—	NFWEN	NFVEN	NFUEN	
Initial Value	0	0	0	0	0	0	0	0
R/W	R/W	R/W	R/W	R/W	R/W	R/W	R/W	R/W

Bit	Bit Name	Initial Value	R/W	Description
b0	NFUEN	0	R/W	Noise Filter U Enable 0: The noise filter for the MTIC5U pin is disabled. 1: The noise filter for the MTIC5U pin is enabled.
b1	NFVEN	0	R/W	Noise Filter V Enable 0: The noise filter for the MTIC5V pin is disabled. 1: The noise filter for the MTIC5V pin is enabled.
b2	NFWEN	0	R/W	Noise Filter W Enable 0: The noise filter for the MTIC5W pin is disabled. 1: The noise filter for the MTIC5W pin is enabled.
b3	—	0	R/W	Reserved These bits are read as 0. The write value should be 0.
b5, b4	NFCS[1:0]	All 0	R/W	Noise Filter Clock Select b5 b4 0 0: P0 ϕ /1 0 1: P0 ϕ /8 1 0: P0 ϕ /32 1 1: Clock source for counting
b7, b6	—	All 0	R/W	Reserved These bits are read as 0. The write value should be 0.

NFUEN Bit (Noise Filter U Enable)

This bit disables or enables the noise filter for input from the MTIC5U pin. Since unexpected edges may be internally generated when the value of this bit is changed, select the output compare function for the relevant pin in the timer I/O control register.

NFVEN Bit (Noise Filter V Enable)

This bit disables or enables the noise filter for input from the MTIC5V pin. Since unexpected edges may be internally generated when the value of this bit is changed, select the output compare function for the relevant pin in the timer I/O control register.

NFWEN Bit (Noise Filter W Enable)

This bit disables or enables the noise filter for input from the MTIC5W pin. Since unexpected edges may be internally generated when the value of this bit is changed, select the output compare function for the relevant pin in the timer I/O control register.

NFCS[1:0] Bits (Noise Filter Clock Select)

These bits set the sampling interval for the noise filters. When setting the NFCS[1:0] bits, wait for two cycles of the selected sampling interval before setting the input-capture function.

16.2.35 Timer A/D Converter Start Request Control Register (TADCR)

(1) MTU4.TADCR

Address(es): MTU4.TADCR H'0_1000_1240

Bit	b15	b14	b13	b12	b11	b10	b9	b8	b7	b6	b5	b4	b3	b2	b1	b0
	BF[1:0]		—	—	—	—	—	—	UT4AE	DT4AE	UT4BE	DT4BE	ITA3AE	ITA4VE	ITB3AE	ITB4VE
Initial Value	0	0	0	0	0	0	0	0	0	0	0	0	0	0	0	0
R/W	R/W	R/W	R/W	R/W	R/W	R/W	R/W	R/W	R/W	R/W	R/W	R/W	R/W	R/W	R/W	R/W

Bit	Bit Name	Initial Value	R/W	Description
b0	ITB4VE	0	R/W	TCIV4 Interrupt Skipping Link Enable*1 *2 *3 0: A/D converter start request signal TRG4BN and TCIV4 interrupt skipping 1 are not linked 1: A/D converter start request signal TRG4BN and TCIV4 interrupt skipping 1 are linked
b1	ITB3AE	0	R/W	TGIA3 Interrupt Skipping Link Enable*1 *2 *3 0: A/D converter start request signal TRG4BN and TGIA3 interrupt skipping 1 are not linked 1: A/D converter start request signal TRG4BN and TGIA3 interrupt skipping 1 are linked
b2	ITA4VE	0	R/W	TCIV4 Interrupt Skipping Link Enable*1 *2 *3 0: A/D converter start request signal TRG4AN and TCIV4 interrupt skipping 1 are not linked 1: A/D converter start request signal TRG4AN and TCIV4 interrupt skipping 1 are linked
b3	ITA3AE	0	R/W	TGIA3 Interrupt Skipping Link Enable*1 *2 *3 0: A/D converter start request signal TRG4AN and TGIA3 interrupt skipping 1 are not linked 1: A/D converter start request signal TRG4AN and TGIA3 interrupt skipping 1 are linked
b4	DT4BE	0	R/W	Down-Count TRG4BN Enable*3 0: A/D converter start requests (TRG4BN) disabled during MTU4.TCNT down-count operation 1: A/D converter start requests (TRG4BN) enabled during MTU4.TCNT down-count operation
b5	UT4BE	0	R/W	Up-Count TRG4BN Enable 0: A/D converter start requests (TRG4BN) disabled during MTU4.TCNT up-count operation 1: A/D converter start requests (TRG4BN) enabled during MTU4.TCNT up-count operation
b6	DT4AE	0	R/W	Down-Count TRG4AN Enable*3 0: A/D converter start requests (TRG4AN) disabled during MTU4.TCNT down-count operation 1: A/D converter start requests (TRG4AN) enabled during MTU4.TCNT down-count operation
b7	UT4AE	0	R/W	Up-Count TRG4AN Enable 0: A/D converter start requests (TRG4AN) disabled during MTU4.TCNT up-count operation 1: A/D converter up requests (TRG4AN) enabled during MTU4.TCNT down-count operation
b13 to b8	—	All 0	R/W	Reserved These bits are read as 0. The write value should be 0.

Bit	Bit Name	Initial Value	R/W	Description
b15, b14	BF[1:0]	All 0	R/W	MTU4.TADCOBRA/TADCOBRB Transfer Timing Select See Table 16.54 for details. These bits specify the transfer timing from MTU4.TADCOBRA and MTU4.TADCOBRB to MTU4.TADCORA and MTU4.TADCORB.

Note: The TADCR register in MTU4 must not be accessed in eight bits; it should be accessed in 16 bits.

Note 1. Clear the bit to 0 when interrupt skipping is disabled (the T3AEN or T4VEN bit in TITCR1A is cleared to 0 or the T3ACOR or T4VCOR bits in TITCR1A are cleared to 0).

Note 2. If link with interrupt skipping is enabled while interrupt skipping is disabled, A/D converter start requests will not be issued.

Note 3. Clear the bit to 0 when complementary PWM mode is not selected.

TADCR enables or disables A/D converter start requests and specifies whether to link A/D converter start requests with interrupt skipping function. The MTU has one TADCR each for MTU4 and MTU7.

Table 16.54 Setting of Transfer Timing by TADCR.BF[1:0] Bits (MTU4)

Bit 15	Bit 14	Description			
BF[1]	BF[0]	Complementary PWM Mode	Reset-Synchronized PWM Mode	PWM Mode 1	Normal Mode
0	0	Does not transfer data from the cycle set buffer register (TADCOBRA or TADCOBRB in MTU4) to the cycle set register (TADCORA or TADCORB in MTU4).	Does not transfer data from the cycle set buffer register (TADCOBRA or TADCOBRB in MTU4) to the cycle set register (TADCORA or TADCORB in MTU4).	Does not transfer data from the cycle set buffer register (TADCOBRA or TADCOBRB in MTU4) to the cycle set register (TADCORA or TADCORB in MTU4).	Does not transfer data from the cycle set buffer register (TADCOBRA or TADCOBRB in MTU4) to the cycle set register (TADCORA or TADCORB in MTU4).
0	1	Transfers data from the cycle set buffer register (TADCOBRA or TADCOBRB in MTU4) to the cycle set register (TADCORA or TADCORB in MTU4) at the crest of the TCNT count in MTU4.	Transfers data from the cycle set buffer register (TADCOBRA or TADCOBRB in MTU4) to the cycle set register (TADCORA or TADCORB in MTU4) when a compare match occurs between TCNT and TGRA in MTU3.	Transfers data from the cycle set buffer register (TADCOBRA or TADCOBRB in MTU4) to the cycle set register (TADCORA or TADCORB in MTU4) when a compare match occurs between TCNT and TGRA in MTU4.	Transfers data from the cycle set buffer register (TADCOBRA or TADCOBRB in MTU4) to the cycle set register (TADCORA or TADCORB in MTU4) when a compare match occurs between TCNT and TGRA in MTU4.
1	0	Transfers data from the cycle set buffer register (TADCOBRA or TADCOBRB in MTU4) to the cycle set register (TADCORA or TADCORB in MTU4) at the trough of the TCNT count in MTU4.	Setting prohibited	Setting prohibited	Setting prohibited
1	1	Transfers data from the cycle set buffer register (TADCOBRA or TADCOBRB in MTU4) to the cycle set register (TADCORA or TADCORB in MTU4) at the crest and trough of the TCNT count in MTU4.	Setting prohibited	Setting prohibited	Setting prohibited

(2) MTU7.TADCR

Address(es): MTU7, TADCR H'0_1000_1A40

Bit	b15	b14	b13	b12	b11	b10	b9	b8	b7	b6	b5	b4	b3	b2	b1	b0
	BF[1:0]		—	—	—	—	—	—	UT7AE	DT7AE	UT7BE	DT7BE	ITA6AE	ITA7VE	ITB6AE	ITB7VE
Initial Value	0	0	0	0	0	0	0	0	0	0	0	0	0	0	0	0
R/W	R/W	R/W	R/W	R/W	R/W	R/W	R/W	R/W	R/W	R/W	R/W	R/W	R/W	R/W	R/W	R/W

Bit	Bit Name	Initial Value	R/W	Description
b0	ITB7VE	0	R/W	TCIV7 Interrupt Skipping Link Enable*1 *2 *3 0: A/D converter start request signal TRG7BN and TCIV7 interrupt skipping 1 are not linked 1: A/D converter start request signal TRG7BN and TCIV7 interrupt skipping 1 are linked
b1	ITB6AE	0	R/W	TGIA6 Interrupt Skipping Link Enable*1 *2 *3 0: A/D converter start request signal TRG7BN and TGIA6 interrupt skipping 1 are not linked 1: A/D converter start request signal TRG7BN and TGIA6 interrupt skipping 1 are linked
b2	ITA7VE	0	R/W	TCIV7 Interrupt Skipping Link Enable*1 *2 *3 0: A/D converter start request signal TRG7AN and TCIV7 interrupt skipping 1 are not linked 1: A/D converter start request signal TRG7AN and TCIV7 interrupt skipping 1 are linked
b3	ITA6AE	0	R/W	TGIA6 Interrupt Skipping Link Enable*1 *2 *3 0: A/D converter start request signal TRG7AN and TGIA6 interrupt skipping 1 are not linked 1: A/D converter start request signal TRG7AN and TGIA6 interrupt skipping 1 are linked
b4	DT7BE	0	R/W	Down-Count TRG7BN Enable*3 0: A/D converter start requests (TRG7BN) disabled during MTU7.TCNT down-count operation 1: A/D converter start requests (TRG7BN) enabled during MTU7.TCNT down-count operation
b5	UT7BE	0	R/W	Up-Count TRG7BN Enable 0: A/D converter start requests (TRG7BN) disabled during MTU7.TCNT up-count operation 1: A/D converter start requests (TRG7BN) enabled during MTU7.TCNT up-count operation
b6	DT7AE	0	R/W	Down-Count TRG7AN Enable*3 0: A/D converter start requests (TRG7AN) disabled during MTU7.TCNT down-count operation 1: A/D converter start requests (TRG7AN) enabled during MTU7.TCNT down-count operation
b7	UT7AE	0	R/W	Up-Count TRG7AN Enable 0: A/D converter start requests (TRG7AN) disabled during MTU7.TCNT up-count operation 1: A/D converter up requests (TRG7AN) enabled during MTU7.TCNT down-count operation
b13 to b8	—	All 0	R/W	Reserved These bits are read as 0. The write value should be 0.

Bit	Bit Name	Initial Value	R/W	Description
b15, b14	BF[1:0]	All 0	R/W	MTU7.TADCOBRA/TADCOBRB Transfer Timing Select See Table 16.55 for details. These bits specify the transfer timing from MTU7.TADCOBRA and MTU7.TADCOBRB to MTU7.TADCORA and MTU7.TADCORB.

Note: The TADCR register in MTU7 must not be accessed in eight bits; it should be accessed in 16 bits.

Note 1. Clear the bit to 0 when interrupt skipping is disabled (the T6AEN or T7VEN bit in TITCR1B is cleared to 0 or the T6ACOR or T7VCOR bits in TITCR1B are cleared to 0).

Note 2. If link with interrupt skipping is enabled while interrupt skipping is disabled, A/D converter start requests will not be issued.

Note 3. Clear the bit to 0 when complementary PWM mode is not selected.

Table 16.55 Setting of Transfer Timing by TADCR.BF[1:0] Bits (MTU7)

Bit 15	Bit 14	Description			
BF[1]	BF[0]	Complementary PWM Mode	Reset-Synchronized PWM Mode	PWM Mode 1	Normal Mode
0	0	Does not transfer data from the cycle set buffer register (TADCOBRA or TADCOBRB in MTU7) to the cycle set register (TADCORA or TADCORB in MTU7).	Does not transfer data from the cycle set buffer register (TADCOBRA or TADCOBRB in MTU7) to the cycle set register (TADCORA or TADCORB in MTU7).	Does not transfer data from the cycle set buffer register (TADCOBRA or TADCOBRB in MTU7) to the cycle set register (TADCORA or TADCORB in MTU7).	Does not transfer data from the cycle set buffer register (TADCOBRA or TADCOBRB in MTU7) to the cycle set register (TADCORA or TADCORB in MTU7).
0	1	Transfers data from the cycle set buffer register (TADCOBRA or TADCOBRB in MTU7) to the cycle set register (TADCORA or TADCORB in MTU7) at the crest of the TCNT count in MTU7.	Transfers data from the cycle set buffer register (TADCOBRA or TADCOBRB in MTU7) to the cycle set register (TADCORA or TADCORB in MTU7) when a compare match occurs between TCNT and TGRA in MTU6.	Transfers data from the cycle set buffer register (TADCOBRA or TADCOBRB in MTU7) to the cycle set register (TADCORA or TADCORB in MTU7) when a compare match occurs between TCNT and TGRA in MTU7.	Transfers data from the cycle set buffer register (TADCOBRA or TADCOBRB in MTU7) to the cycle set register (TADCORA or TADCORB in MTU7) when a compare match occurs between TCNT and TGRA in MTU7.
1	0	Transfers data from the cycle set buffer register (TADCOBRA or TADCOBRB in MTU7) to the cycle set register (TADCORA or TADCORB in MTU7) at the trough of the TCNT count in MTU7.	Setting prohibited	Setting prohibited	Setting prohibited
1	1	Transfers data from the cycle set buffer register (TADCOBRA or TADCOBRB in MTU7) to the cycle set register (TADCORA or TADCORB in MTU7) at the crest and trough of the TCNT count in MTU7.	Setting prohibited	Setting prohibited	Setting prohibited

16.2.36 Timer A/D Converter Start Request Cycle Set Registers (TADCORA and TADCORB)

Address(es): MTU4.TADCORA H'0_1000_1244, MTU4.TADCORB H'0_1000_1246, MTU7.TADCORA H'0_1000_1A44, MTU7.TADCORB H'0_1000_1A46

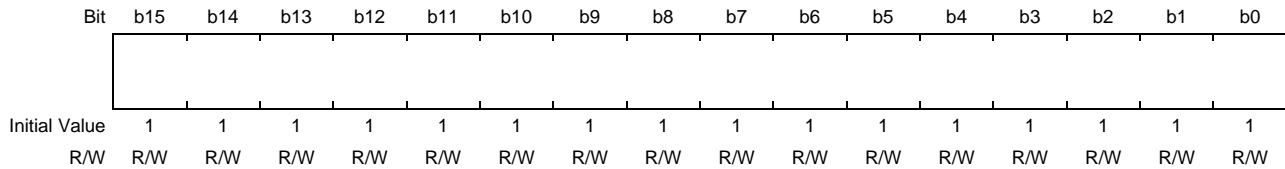

Note: TADCORA and TADCORB must not be accessed in eight bits; it should be accessed in 16 bits.

Note 1. When the A/D converter start request delaying function linked with skipping function 1 (for details, see **Section 16.3.9(5), A/D Converter Start Request Delaying Function Linked with Interrupt Skipping Function 1**) is used, the value of this register should be H'0002 to TCDRA setting - 2 in MTU4 and H'0002 to TCDRB setting - 2 in MTU7.

Note 2. When interrupt skipping function 2 is used and the difference between the TADCORA value and the TADCORB value is small, the skipping count may not be counted correctly and the A/D converter start request may not be generated with the expected timing in some cases. The TADCORA and TADCORB values should satisfy the following conditions.

(1) When skipping function 2 is specified with the skipping count set to 0

- The difference between the TADCORA and TADCORB values should be equal to or greater than 4.
- The TADCORA compare interval should be equal to or greater than 4 P0φ cycles (the TADCORA update value should be the previous value + 4 or greater, or previous value - 4 or smaller).
- The TADCORB compare interval should be equal to or greater than 4 P0φ cycles (the TADCORB update value should be the previous value + 4 or greater, or previous value - 4 or smaller).

(2) When skipping function 2 is specified with the skipping count set to 1 or greater

- The difference between the TADCORA and TADCORB values should be equal to or greater than 2.
- The TADCORB compare interval should be equal to or greater than 2 P0φ cycles (the TADCORB update value should be the previous value + 2 or greater, or previous value - 2 or smaller).

TADCORA and TADCORB are 16-bit readable/writable registers that issue a corresponding A/D converter start request when the MTUn.TCNT (n = 4, 7) count reaches the value in TADCORA or TADCORB.

MTUn.TADCORA and TADCORB are initialized to H'FFFF by a reset.

16.2.37 Timer A/D Converter Start Request Cycle Set Buffer Registers (TADCOBRA and TADCOBRB)

Address(es): MTU4.TADCORA H'0_1000_1248, MTU4.TADCORB H'0_1000_124A, MTU7.TADCORA H'0_1000_1A48, MTU7.TADCORB H'0_1000_1A4A

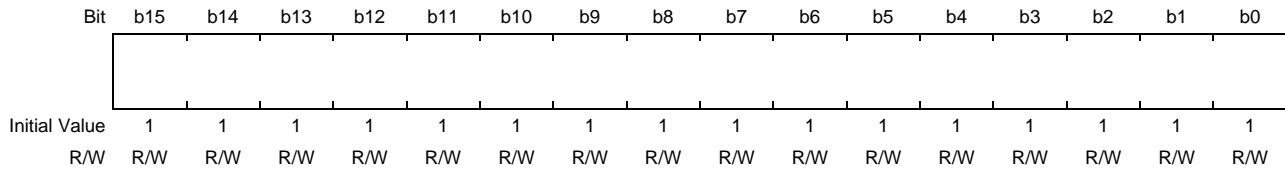

Note: TADCOBRA and TADCOBRB must not be accessed in eight bits; it should be accessed in 16 bits.

TADCOBRA and TADCOBRB are 16-bit readable/writable registers whose values are transferred to TADCORA and TADCORB, respectively, when the crest or trough of the MTUn.TCNT count is reached.

TADCOBRA and TADCOBRB are initialized to H'FFFF by a reset.

16.2.38 Timer Interrupt Skipping Mode Registers (TITMRA and TITMRB)

Address(es): MTU.TITMRA H'0_1000_123A, MTU.TITMRB H'0_1000_1A3A

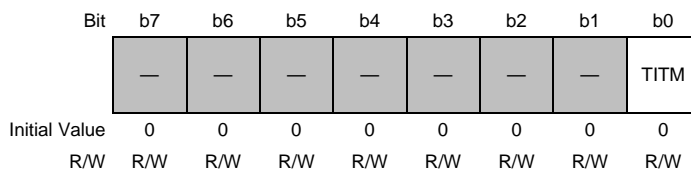

Bit	Bit Name	Initial Value	R/W	Description
b0	TITM	0	R/W	Interrupt Skipping Function Select Selects one of the two types of interrupt skipping functions. 0: Selects interrupt skipping function 1*1 1: Selects interrupt skipping function 2*2
b7 to b1	—	All 0	R/W	Reserved These bits are read as 0. The write value should be 0.

Note 1. TITCR1A or TITCR1B is used to enable interrupt skipping function 1.

Note 2. TITCR2A or TITCR2B is used to enable interrupt skipping function 2.

TITMRA and TITMRB are used to select either of two skipping functions for the TITMRA and TITMRB registers.

16.2.39 Timer Interrupt Skipping Set Registers 1 (TITCR1A and TITCR1B)

(1) MTU.TITCR1A

Address(es): MTU.TITMRA H'0_1000_1230

Bit	b7	b6	b5	b4	b3	b2	b1	b0
	T3AEN	T3ACOR[2:0]			T4VEN	T4VCOR[2:0]		
Initial Value	0	0	0	0	0	0	0	0
	R/W	R/W	R/W	R/W	R/W	R/W	R/W	R/W

Bit	Bit Name	Initial Value	R/W	Description
b2 to b0	T4VCOR[2:0]	All 0	R/W	TCIV4 Interrupt Skipping Count Setting These bits specify the TCIV4 interrupt skipping count within the range from 0 to 7.* ¹ For details, see Table 16.56 .
b3	T4VEN	0	R/W	T4VEN 0: TCIV4 interrupt skipping disabled 1: TCIV4 interrupt skipping enabled
b6 to b4	T3ACOR[2:0]	All 0	R/W	TGIA3 Interrupt Skipping Count Setting These bits specify the TGIA3 interrupt skipping count within the range from 0 to 7. For details, see Table 16.57 .
b7	T3AEN	0	R/W	T3AEN 0: TGIA3 interrupt skipping disabled 1: TGIA3 interrupt skipping enabled

Note 1. When 0 is specified for the interrupt skipping count, no interrupt skipping will be performed.
Before changing the interrupt skipping count, be sure to clear the TITCR1A.T3AEN and TITCR1A.T4VEN bits to 0 to clear the skipping counter (TITCNT1A).

(2) MTU.TITCR1B

Address(es): MTU.TITCR1B H'0_1000_1A30

Bit	b7	b6	b5	b4	b3	b2	b1	b0
	T6AEN	T6ACOR[2:0]			T7VEN	T7VCOR[2:0]		
Initial Value	0	0	0	0	0	0	0	0
	R/W	R/W	R/W	R/W	R/W	R/W	R/W	R/W

Bit	Bit Name	Initial Value	R/W	Description
b2 to b0	T7VCOR[2:0]	All 0	R/W	TCIV7 Interrupt Skipping Count Setting These bits specify the TCIV7 interrupt skipping count within the range from 0 to 7.* ¹ For details, see Table 16.58 .
b3	T7VEN	0	R/W	T7VEN 0: TCIV7 interrupt skipping disabled 1: TCIV7 interrupt skipping enabled
b6 to b4	T6ACOR[2:0]	All 0	R/W	TGIA6 Interrupt Skipping Count Setting These bits specify the TGIA6 interrupt skipping count within the range from 0 to 7.* ¹ For details, see Table 16.59 .
b7	T6AEN	0	R/W	T6AEN 0: TGIA6 interrupt skipping disabled 1: TGIA6 interrupt skipping enabled

Note 1. When 0 is specified for the interrupt skipping count, no interrupt skipping will be performed.
Before changing the interrupt skipping count, be sure to clear the TITCR1B.T6AEN and TITCR1B.T7VEN bits to 0 to clear the skipping counter (TITCNT1B).

TITCR1A and TITCR1B enable or disable interrupt skipping and specify the interrupt skipping count.

The setting in the TITCR1A (TITCR1B) register is valid only while the TITM bit in TITMRA (TITMRB) is set to 0; when the TITM bit in TITMRA (TITMRB) is set to 1, the setting in TITCR1A (TITCR1B) is cleared.

Table 16.56 Setting of Interrupt Skipping Count by T4VCOR[2:0] Bits

Bit 2	Bit 1	Bit 0	Description
T4VCOR2	T4VCOR1	T4VCOR0	
0	0	0	Does not skip TCIV4 interrupts.
		1	Sets the TCIV4 interrupt skipping count to 1.
	1	0	Sets the TCIV4 interrupt skipping count to 2.
		1	Sets the TCIV4 interrupt skipping count to 3.
1	0	0	Sets the TCIV4 interrupt skipping count to 4.
		1	Sets the TCIV4 interrupt skipping count to 5.
	1	0	Sets the TCIV4 interrupt skipping count to 6.
		1	Sets the TCIV4 interrupt skipping count to 7.

Table 16.57 Setting of Interrupt Skipping Count by T3ACOR[2:0] Bits

Bit 6	Bit 5	Bit 4	Description
T3ACOR2	T3ACOR1	T3ACOR0	
0	0	0	Does not skip TGIA3 interrupts.
		1	Sets the TGIA3 interrupt skipping count to 1.
	1	0	Sets the TGIA3 interrupt skipping count to 2.
1	0	1	Sets the TGIA3 interrupt skipping count to 3.
		0	Sets the TGIA3 interrupt skipping count to 4.
	1	Sets the TGIA3 interrupt skipping count to 5.	
	1	0	Sets the TGIA3 interrupt skipping count to 6.
		1	Sets the TGIA3 interrupt skipping count to 7.

Table 16.58 Setting of Interrupt Skipping Count by T7VCOR[2:0] Bits

Bit 2	Bit 1	Bit 0	Description
T7VCOR2	T7VCOR1	T7VCOR0	
0	0	0	Does not skip TCIV7 interrupts.
		1	Sets the TCIV7 interrupt skipping count to 1.
	1	0	Sets the TCIV7 interrupt skipping count to 2.
1	0	1	Sets the TCIV7 interrupt skipping count to 3.
		0	Sets the TCIV7 interrupt skipping count to 4.
	1	Sets the TCIV7 interrupt skipping count to 5.	
	1	0	Sets the TCIV7 interrupt skipping count to 6.
		1	Sets the TCIV7 interrupt skipping count to 7.

Table 16.59 Setting of Interrupt Skipping Count by T6ACOR[2:0] Bits

Bit 6	Bit 5	Bit 4	Description
T6ACOR2	T6ACOR1	T6ACOR0	
0	0	0	Does not skip TGIA6 interrupts.
		1	Sets the TGIA6 interrupt skipping count to 1.
	1	0	Sets the TGIA6 interrupt skipping count to 2.
1	0	1	Sets the TGIA6 interrupt skipping count to 3.
		0	Sets the TGIA6 interrupt skipping count to 4.
	1	Sets the TGIA6 interrupt skipping count to 5.	
	1	0	Sets the TGIA6 interrupt skipping count to 6.
		1	Sets the TGIA6 interrupt skipping count to 7.

16.2.40 Timer Interrupt Skipping Counters 1 (TITCNT1A and TITCNT1B)

(1) MTU.TITCNT1A

Address(es): MTU.TITCNT1A H'0_1000_1231

Bit	b7	b6	b5	b4	b3	b2	b1	b0
	—	T3ACNT[2:0]			—	T4VCNT[2:0]		
Initial Value	0	0	0	0	0	0	0	0
R/W	R	R	R	R	R	R	R	R

Bit	Bit Name	Initial Value	R/W	Description
b2 to b0	T4VCNT[2:0]	All 0	R	TCIV4 Interrupt Counter While the T4VEN bit in TITCR1A is set to 1, the count in these bits is incremented every time a TCIV4 interrupt occurs.
b3	—	0	R	Reserved This bit is read as 0.
b6 to b4	T3ACNT[2:0]	All 0	R	TGIA3 Interrupt Counter While the T3AEN bit in TITCR1A is set to 1, the count in these bits is incremented every time a TGIA3 interrupt occurs.
b7	—	0	R	Reserved This bit is read as 0.

Note: To clear the TITCNT1A, clear the TITCR1A.T3AEN and TITCR1A.T4VEN bits to 0.

TITCNT1A and TITCNT1B are 8-bit readable/writable counters. TITCNTA and TITCNTB retain their values even after stopping the count operation of MTU3.TCNT and MTU4.TCNT (MTU6.TCNT and MTU7.TCNT).

T4VCNT[2:0] Bits (TCIV4 Interrupt Counter)

[Clearing conditions]

- When the TITM bit in TITMRA is 1
- When the T4VEN bit in TITCR1A is cleared to 0
- When the T4VCOR[2:0] bits in TITCR1A are cleared to 000b
- When the T4VCNT[2:0] bits in TITCNT1A match the T4VCOR[2:0] bits in TITCR1A

T3ACNT[2:0] Bits (TGIA3 Interrupt Counter)

[Clearing conditions]

- When the TITM bit in TITMRA is 1
- When the T3AEN bit in TITCR1A is cleared to 0
- When the T3ACOR[2:0] bits in TITCR1A are cleared to 000b
- When the T3ACNT[2:0] bits in TITCNT1A match the T3ACOR[2:0] bits in TITCR1A

(2) MTU.TITCNT1B

Address(es): MTU.TITCNT1B H'0_1000_1A31

Bit	b7	b6	b5	b4	b3	b2	b1	b0
	—	T6ACNT[2:0]			—	T7VCNT[2:0]		
Initial Value	0	0	0	0	0	0	0	0
R/W	R	R	R	R	R	R	R	R

Bit	Bit Name	Initial Value	R/W	Description
b2 to b0	T7VCNT[2:0]	All 0	R	TCIV7 Interrupt Counter While the T7VEN bit in TITCR1B is set to 1, the count in these bits is incremented every time a TCIV7 interrupt occurs.
b3	—	0	R	Reserved This bit is read as 0.
b6 to b4	T6ACNT[2:0]	All 0	R	TGIA6 Interrupt Counter While the T6AEN bit in TITCR1B is set to 1, the count in these bits is incremented every time a TGIA6 interrupt occurs.
b7	—	0	R	Reserved This bit is read as 0.

Note: To clear the TITCNT1B, clear the TITCR1B.T6AEN and TITCR1B.T7VEN bits to 0.

T7VCNT[2:0] Bits (TCIV7 Interrupt Counter)

[Clearing conditions]

- When the TITM bit in TITMRB is 1
- When the T7VEN bit in TITCR1B is cleared to 0
- When the T7VCOR[2:0] bits in TITCR1B are cleared to 000b
- When the T7VCNT[2:0] bits in TITCNT1B match the T7VCOR[2:0] bits in TITCR1B

T6ACNT[2:0] Bits (TGIA6 Interrupt Counter)

[Clearing conditions]

- When the TITM bit in TITMRB is 1
- When the T6AEN bit in TITCR1B is cleared to 0
- When the T6ACOR[2:0] bits in TITCR1B are cleared to 000b
- When the T6ACNT[2:0] bits in TITCNT1B match the T6ACOR[2:0] bits in TITCR1B

16.2.41 Timer Interrupt Skipping Set Registers 2 (TITCR2A and TITCR2B)

(1) MTU.TITCR2A

Address(es): MTU.TITCR2A H'0_1000_123B

Bit	b7	b6	b5	b4	b3	b2	b1	b0
	—	—	—	—	—	TRG4COR[2:0]		
Initial Value	0	0	0	0	0	0	0	0
	R/W	R/W	R/W	R/W	R/W	R/W	R/W	R/W

Bit	Bit Name	Initial Value	R/W	Description
b2 to b0	TRG4COR [2:0]	All 0	R/W	TRG4AN/TRG4BN Interrupt Skipping Count Setting These bits specify the TRG4AN/TRG4BN interrupt skipping count within the range from 0 to 7. For details, see Table 16.60 .
b7 to b3	—	All 0	R/W	Reserved These bits are read as 0. The write value should be 0.

TITCR2A and TITCR2B specify the interrupt skipping count for TRG4AN and TRG4BN (TRG7AN and TRG7BN). This setting is valid only while TITMRA or TITMRB is set to 1.

Table 16.60 Setting of Interrupt Skipping Count by TRG4COR[2:0] Bits

Bit 2	Bit 1	Bit 0	Description
TRG4COR2	TRG4COR1	TRG4COR0	
0	0	0	Does not skip TRG4AN and TRG4BN interrupts.
		1	Sets the TRG4AN and TRG4BN interrupt skipping count to 1.
	1	0	Sets the TRG4AN and TRG4BN interrupt skipping count to 2.
		1	Sets the TRG4AN and TRG4BN interrupt skipping count to 3.
1	0	0	Sets the TRG4AN and TRG4BN interrupt skipping count to 4.
		1	Sets the TRG4AN and TRG4BN interrupt skipping count to 5.
	1	0	Sets the TRG4AN and TRG4BN interrupt skipping count to 6.
		1	Sets the TRG4AN and TRG4BN interrupt skipping count to 7.

(2) MTU.TITCR2B

Address(es): MTU.TITCR2B H'0_1000_1A3B

Bit	b7	b6	b5	b4	b3	b2	b1	b0
	—	—	—	—	—	TRG7COR[2:0]		
Initial Value	0	0	0	0	0	0	0	0
R/W	R/W	R/W	R/W	R/W	R/W	R/W	R/W	R/W

Bit	Bit Name	Initial Value	R/W	Description
b2 to b0	TRG7COR [2:0]	All 0	R/W	TRG7AN/TRG7BN Interrupt Skipping Count Setting These bits specify the TRG7AN/TRG7BN interrupt skipping count within the range from 0 to 7. For details, see Table 16.61 .
b7 to b3	—	All 0	R/W	Reserved These bits are read as 0. The write value should be 0.

Table 16.61 Setting of Interrupt Skipping Count by TRG7COR[2:0] Bits

Bit 2	Bit 1	Bit 0	Description
TRG7COR2	TRG7COR1	TRG7COR0	Description
0	0	0	Does not skip TRG7AN and TRG7BN interrupts.
		1	Sets the TRG7AN and TRG7BN interrupt skipping count to 1.
		0	Sets the TRG7AN and TRG7BN interrupt skipping count to 2.
1	1	0	Sets the TRG7AN and TRG7BN interrupt skipping count to 3.
		1	Sets the TRG7AN and TRG7BN interrupt skipping count to 4.
		0	Sets the TRG7AN and TRG7BN interrupt skipping count to 5.
1	1	0	Sets the TRG7AN and TRG7BN interrupt skipping count to 6.
		1	Sets the TRG7AN and TRG7BN interrupt skipping count to 7.

16.2.42 Timer Interrupt Skipping Counters 2 (TITCNT2A and TITCNT2B)

(1) MTU.TITCNT2A

Address(es): MTU.TITCNT2A H'0_1000_123C

Bit	b7	b6	b5	b4	b3	b2	b1	b0
	—	—	—	—	—	TRG4CNT[2:0]		
Initial Value	0	0	0	0	0	0	0	0
R/W	R	R	R	R	R	R	R	R

Bit	Bit Name	Initial Value	R/W	Description
b2 to b0	TRG4CNT [2:0]	All 0	R	TRG4AN/TRG4BN Interrupt Counter These bits start counting from the value set in TRG4COR[2:0] and the count decrements every time TRG4AN or TRG4BN is generated. When the count reaches 0 and is reloaded, the TRG4AN and TRG4BN interrupts become valid.
b7 to b3	—	All 0	R	Reserved These bits are read as 0.

TITCNT2A and TITCNT2B start counting from the values set in the TRG4COR[2:0] and TRG7COR[2:0] bits and the count decrements every time TRG4AN or TRG4BN (TITCNT2A) is generated or TRG7AN or TRG7BN (TITCNT2B) is generated. When the count reaches 0 and is reloaded, the TRG4AN and TRG4BN interrupts or the TRG7AN and TRG7BN interrupts become valid.

TRG4CNT[2:0] Bits (TRG4AN/TRG4BN Interrupt Counter)

These bits start counting from the value set in the TRG4COR[2:0] bits and the count decrements every time a TRG4AN or TRG4BN interrupt is generated. When the count reaches 0 and is reloaded, the TRG4AN and TRG4BN interrupts become valid.

[Clearing conditions]

- When the TITM bit in TITMRA is 0
- When the TRG4COR[2:0] bits in TITCR2A are cleared to 000b
- When the count of TRG4AN and TRG4BN occurrence matches the TRG4COR[2:0] value in TITCR2A

(2) MTU.TITCNT2B

Address(es): MTU.TITCNT2B H'0_1000_1A3C

Bit	b7	b6	b5	b4	b3	b2	b1	b0
	—	—	—	—	—	TRG7CNT[2:0]		
Initial Value	0	0	0	0	0	0	0	0
R/W	R	R	R	R	R	R	R	R

Bit	Bit Name	Initial Value	R/W	Description
b2 to b0	TRG7CNT [2:0]	All 0	R	TRG7AN/TRG7BN Interrupt Counter These bits start counting from the value set in TRG7COR[2:0] and the count decrements every time TRG7AN or TRG7BN is generated. When the count reaches 0 and is reloaded, the TRG7AN and TRG7BN interrupts become valid.
b7 to b3	—	All 0	R	Reserved These bits are read as 0.

TRG7CNT[2:0] Bits (TRG7AN/TRG7BN Interrupt Counter)

These bits start counting from the value set in the TRG7COR[2:0] bits and the count decrements every time a TRG7AN or TRG7BN interrupt is generated. When the count reaches 0 and is reloaded, the TRG7AN and TRG7BN interrupts become valid.

[Clearing conditions]

- When the TITM bit in TITMRB is 0
- When the TRG7COR[2:0] bits in TITCR2B are cleared to 000b
- When the count of TRG7AN and TRG7BN occurrence matches the TRG7COR[2:0] value in TITCR2B

16.2.43 Bus Master Interface

The timer counter (MTU8.TCNT), general registers (MTU8.TGRn) for MTU8, and MTU1.TCNTLW, MTU1.TGRALW, and MTU1.TGRBLW registers when TMDR3.LWA = 1 are 32-bit registers. A 32-bit data bus to the bus master enables 32-bit read/write access. 8- and 16-bit read/write are not allowed. Access these registers in 32-bit units.

Excluding MTU8, the timer counters (MTU0.TCNT to MTU7.TCNT), general registers (MTU0.TGRn to MTU7.TGRn), timer subcounters (TCNTSA and TCNTSB), timer cycle buffer registers (TCBRA and TCBRB), timer dead time data registers (TDDRA and TDDRb), timer cycle data registers (TCDRA and TCDRB), timer A/D converter start request control registers (MTU4.TADCR and MTU7.TADCR), timer A/D converter start request cycle set registers (MTU4.TADCORA, MTU4.TADCORB, MTU7.TADCORA, and MTU7.TADCORB), and timer A/D converter start request cycle set buffer registers (MTU4.TADCOBRA, MTU4.TADCOBRB, MTU7.TADCOBRA, and MTU7.TADCOBRB) are 16-bit registers. A 16-bit data bus to the bus master enables 16-bit read/write access. 8-bit read/write is not allowed. Access the registers in 16-bit units.

All registers other than the above registers are 8-bit registers. Read from/write to these registers in 8-bit units.

16.3 Operation

16.3.1 Basic Functions

Each channel has TCNT and TGR. TCNT in each channel performs up-counting and is also capable of free-running count, periodic count, and external event count operations.

Each TGR can be used as an input capture register or an output compare register.

(1) Counter Operation

When one of bits CST0 to CST4 and CST8 in TSTRA, bits CST6 and CST7 in TSTRB, and bits CSTU5, CSTV5, and CSTW5 in MTU5.TSTR is set to 1, TCNT for the corresponding channel begins counting. TCNT can perform various count operations such as free-running count or periodic count operations.

(a) Example of Count Operation Setting Procedure

Figure 16.5 shows an example of the count operation setting procedure.

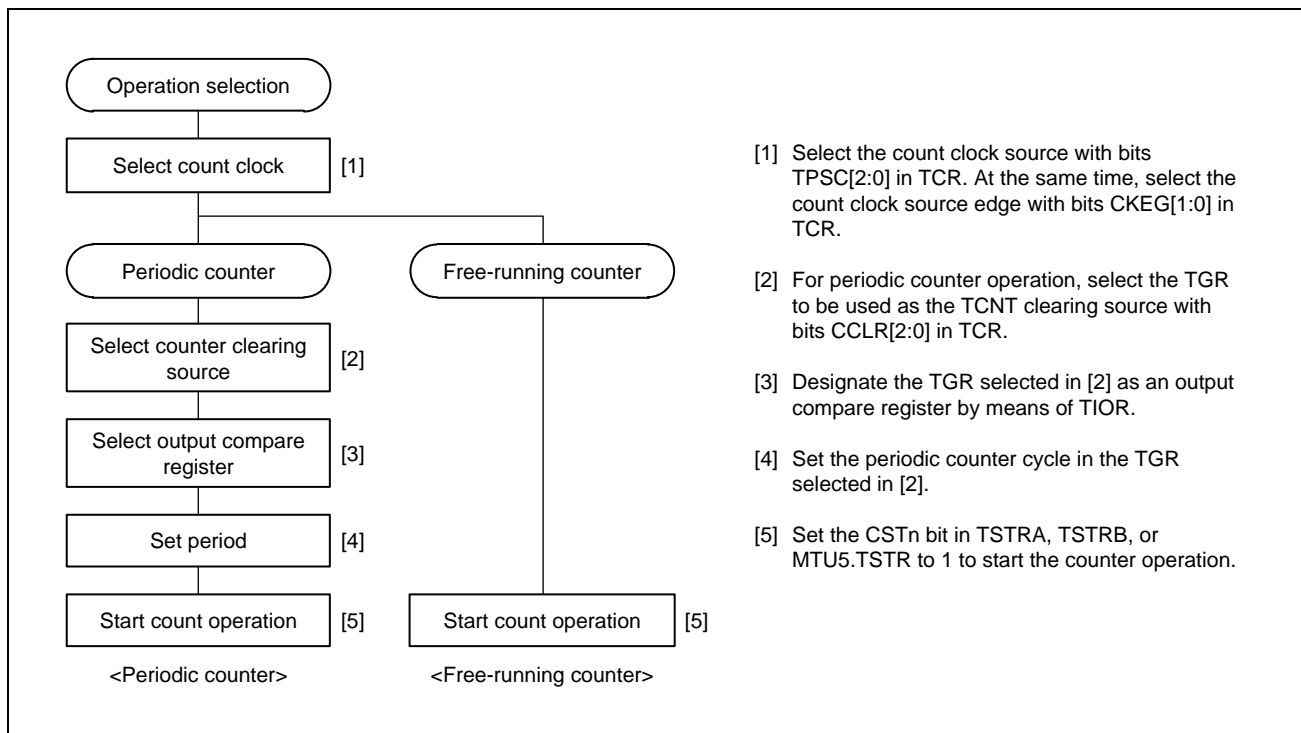

Figure 16.5 Example of Count Operation Setting Procedure

(b) Free-Running Count Operation and Periodic Count Operation

Immediately after a reset, all TCNT counters are designated as free-running counters. When the CSTn bit in TSTRA, TSTRB, or TSTR in MTU5 is set to 1, the corresponding TCNT counter starts up-counting as a free-running counter. When TCNT overflows (from H'FFFF to H'0000), if the corresponding TIER.TCIEV bit is 1, an interrupt request is issued to the CPU. After an overflow, TCNT starts counting up again from H'0000.

Figure 16.6 illustrates free-running counter operation.

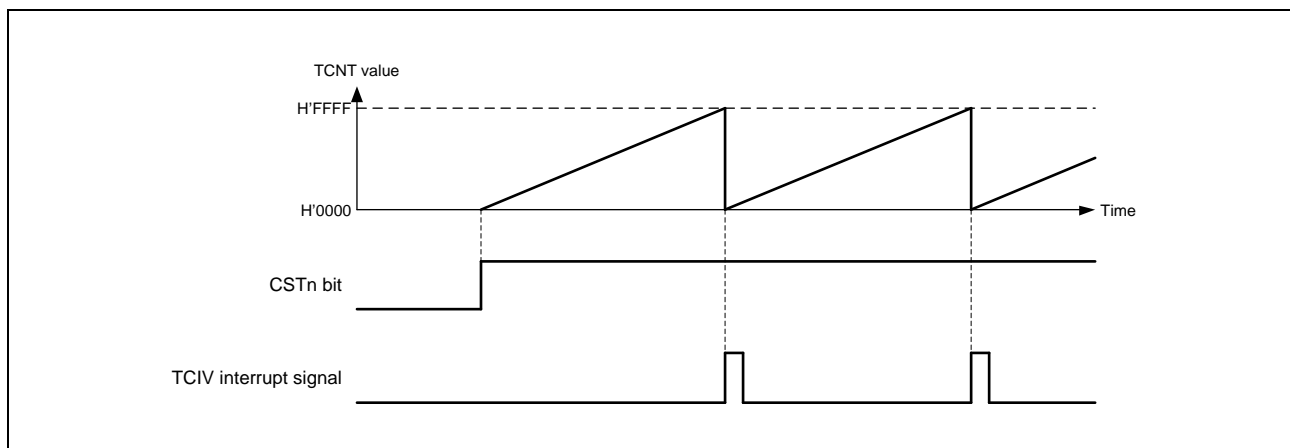

Figure 16.6 Free-Running Counter Operation

When compare match is selected as the TCNT clearing source, TCNT for the relevant channel performs periodic count operation. TGR for setting the cycle is designated as an output compare register, and counter clearing by compare match is selected by means of bits CCLR[2:0] in TCR. After the settings have been made, TCNT starts up-counting as a periodic counter when the corresponding CSTn bit in TSTRA, TSTRB, or TSTR in MTU5 is set to 1. When the count matches the value in TGR, TCNT is cleared to H'0000.

If the value of the corresponding TIER.TGIE bit is 1 at this point, an interrupt request is issued to the CPU. After a compare match, TCNT starts counting up again from H'0000.

Figure 16.7 illustrates periodic counter operation.

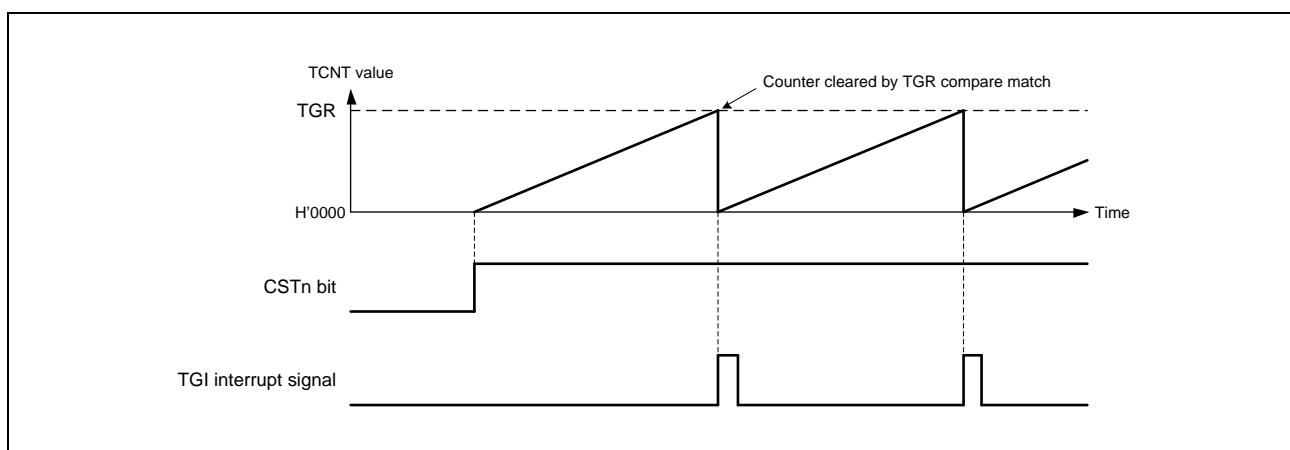

Figure 16.7 Periodic Counter Operation

(2) Waveform Output by Compare Match

Upon compare match, low, high, or toggle output from the corresponding pin can be performed. The compare match output operation is not available in MTU5.

(a) Example of Procedure for Setting Waveform Output by Compare Match

Figure 16.8 shows an example of the procedure for setting waveform output by compare match

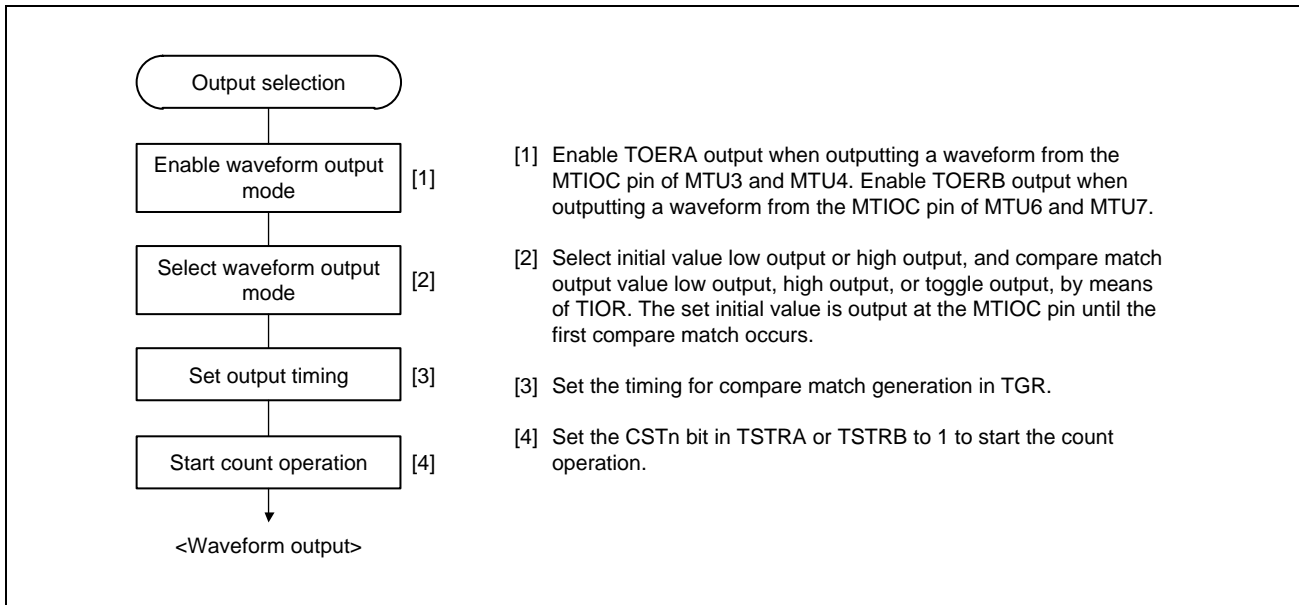

Figure 16.8 Example of Procedure for Setting Waveform Output by Compare Match

(b) Examples of Waveform Output Operation

Figure 16.9 shows an example of low output and high output.

In this example, TCNT has been designated as a free-running counter, and settings have been made so that high is output by compare match A and low is output by compare match B. When the pin level is the same as the specified level, the pin level does not change.

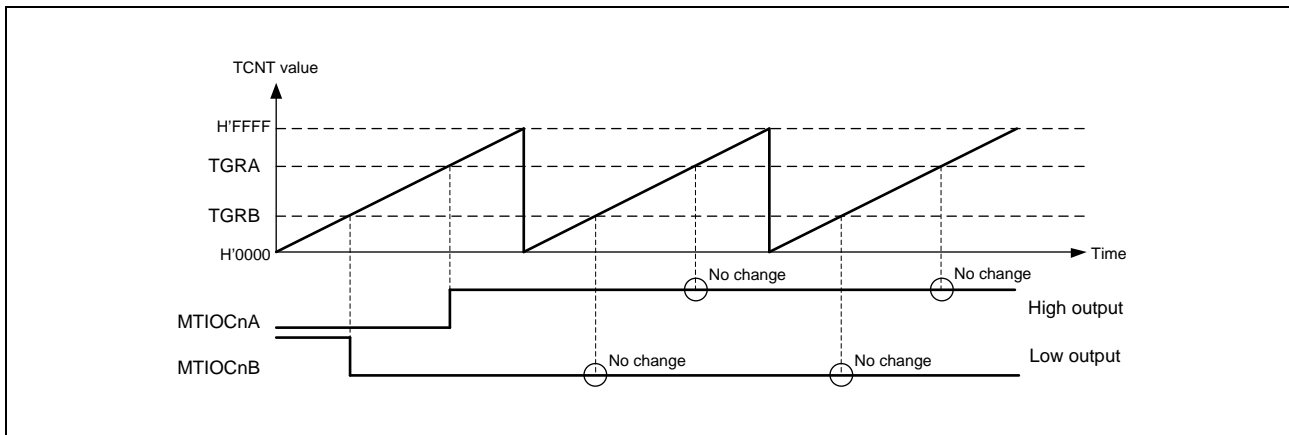

Figure 16.9 Example of low output and high output Operation (n = 0 to 4, 6, 7, 8)

Figure 16.10 shows an example of toggle output.

In this example, TCNT has been designated as a periodic counter (with counter clearing on compare match B), and settings have been made so that the output is toggled by both compare match A and compare match B.

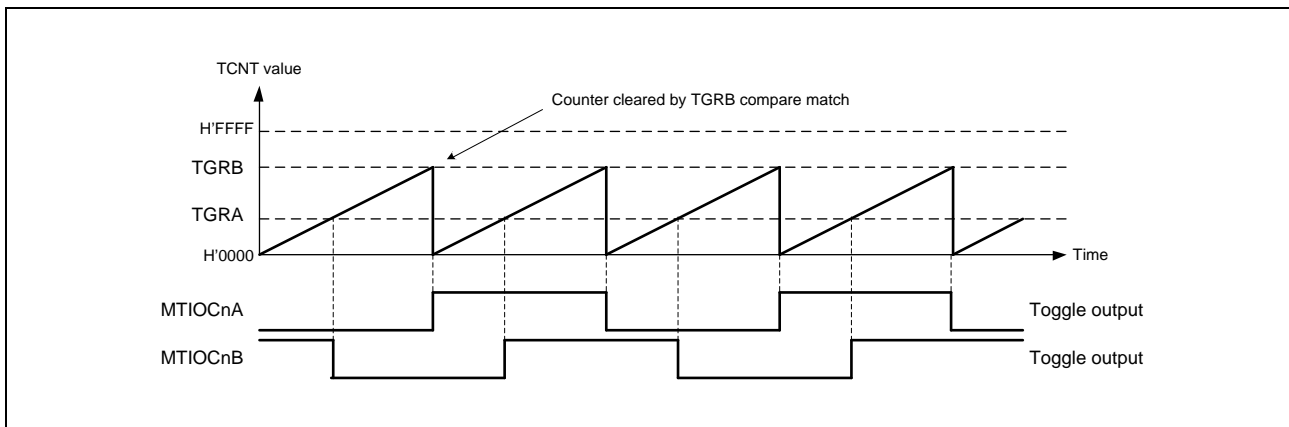

Figure 16.10 Example of Toggle Output Operation (n = 0 to 4, 6, 7, 8)

(3) Input Capture Function

The TCNT value can be transferred to TGR on detection of the MTIOC_nm, MTIC5U, MTIC5V, or MTIC5W pin (n = 0 to 4, 6, 7, 8; m = A to D), input edge.

The rising edge, falling edge, or both edges can be selected as the detection edge. For MTU0 and MTU1, another channel's count clock or compare match signal can also be specified as the input capture source.

NOTE

When another channel's count clock is used as the input capture input for MTU0 and MTU1, P0 ϕ /1 should not be selected as the count clock used for input capture input. Input capture will not be generated if P0 ϕ /1 is selected.

(a) Example of Input Capture Operation Setting Procedure

Figure 16.11 shows an example of the input capture operation setting procedure.

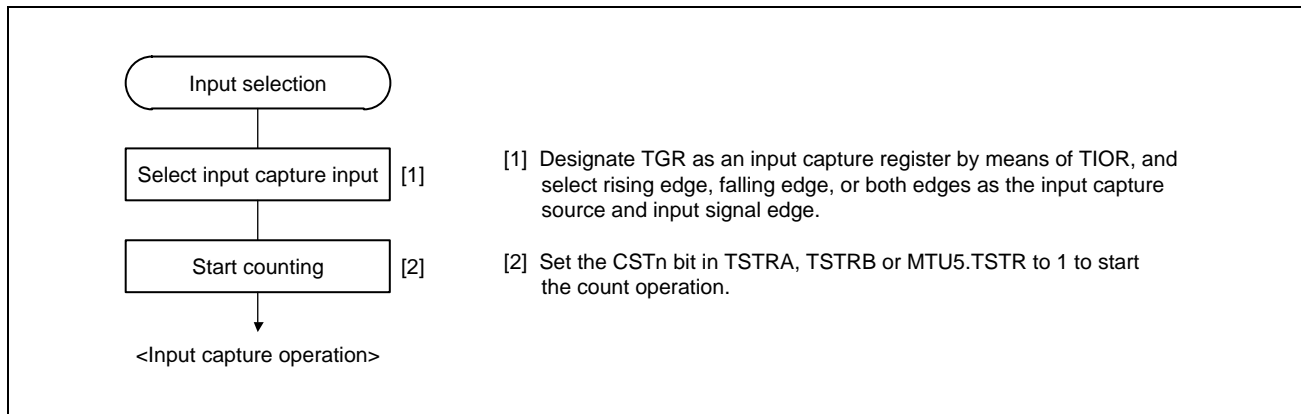

Figure 16.11 Example of Input Capture Operation Setting Procedure

(b) Example of Input Capture Operation

Figure 16.12 shows an example of input capture operation.

In this example, both rising and falling edges have been selected as the MTIOCnA pin input capture input edge, the falling edge has been selected as the MTIOCnB pin input capture input edge, and counter clearing by TGRB input capture has been designated for TCNT. (n = 0 to 4, 6, 7, 8)

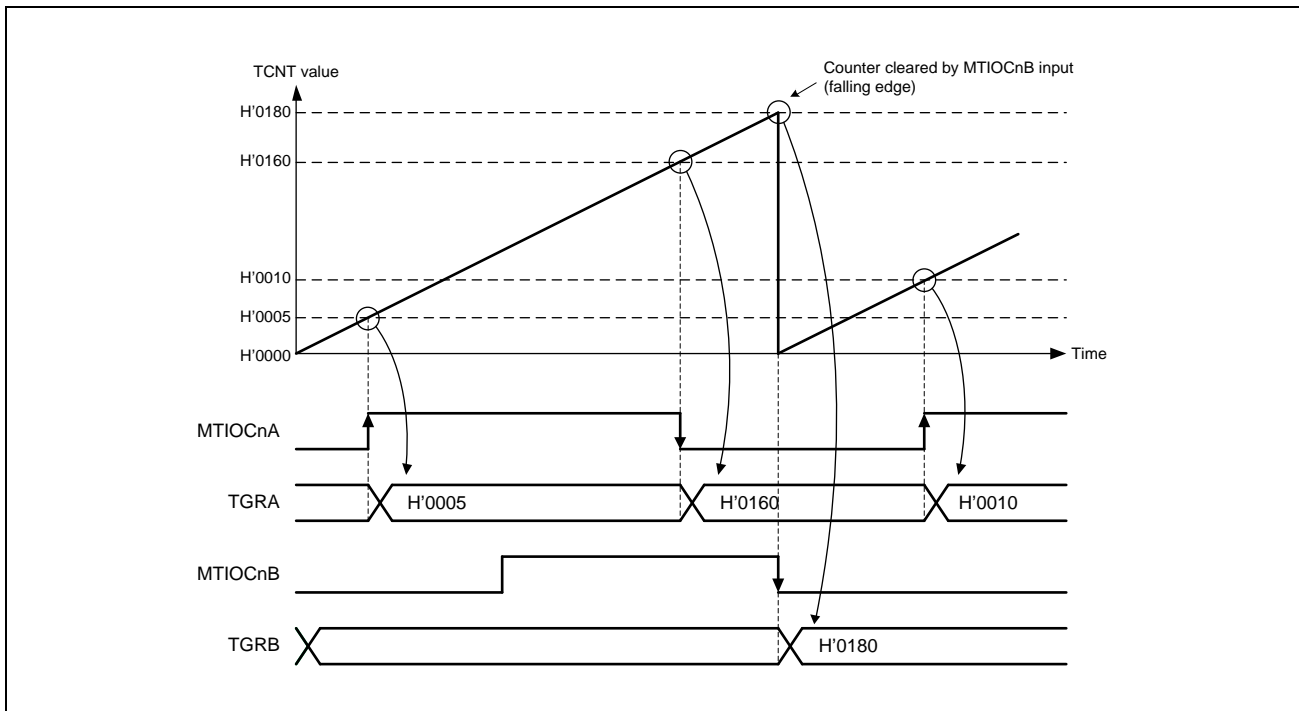

Figure 16.12 Example of Input Capture Operation (n = 0 to 4, 6, 7, 8)

16.3.2 Synchronous Operation

In synchronous operation, the values in multiple TCNT counters can be modified simultaneously (synchronous setting). In addition, multiple TCNT counters can be cleared simultaneously (synchronous clearing) by making the appropriate setting in TCR.

Synchronous operation can increase the number of TGR registers assigned to the same time base.

MTU0 to MTU4, MTU6, and MTU7 can all be designated for synchronous operation. MTU5 and MTU8 cannot be used for synchronous operation.

(1) Example of Synchronous Operation Setting Procedure

Figure 16.13 shows an example of the synchronous operation setting procedure.

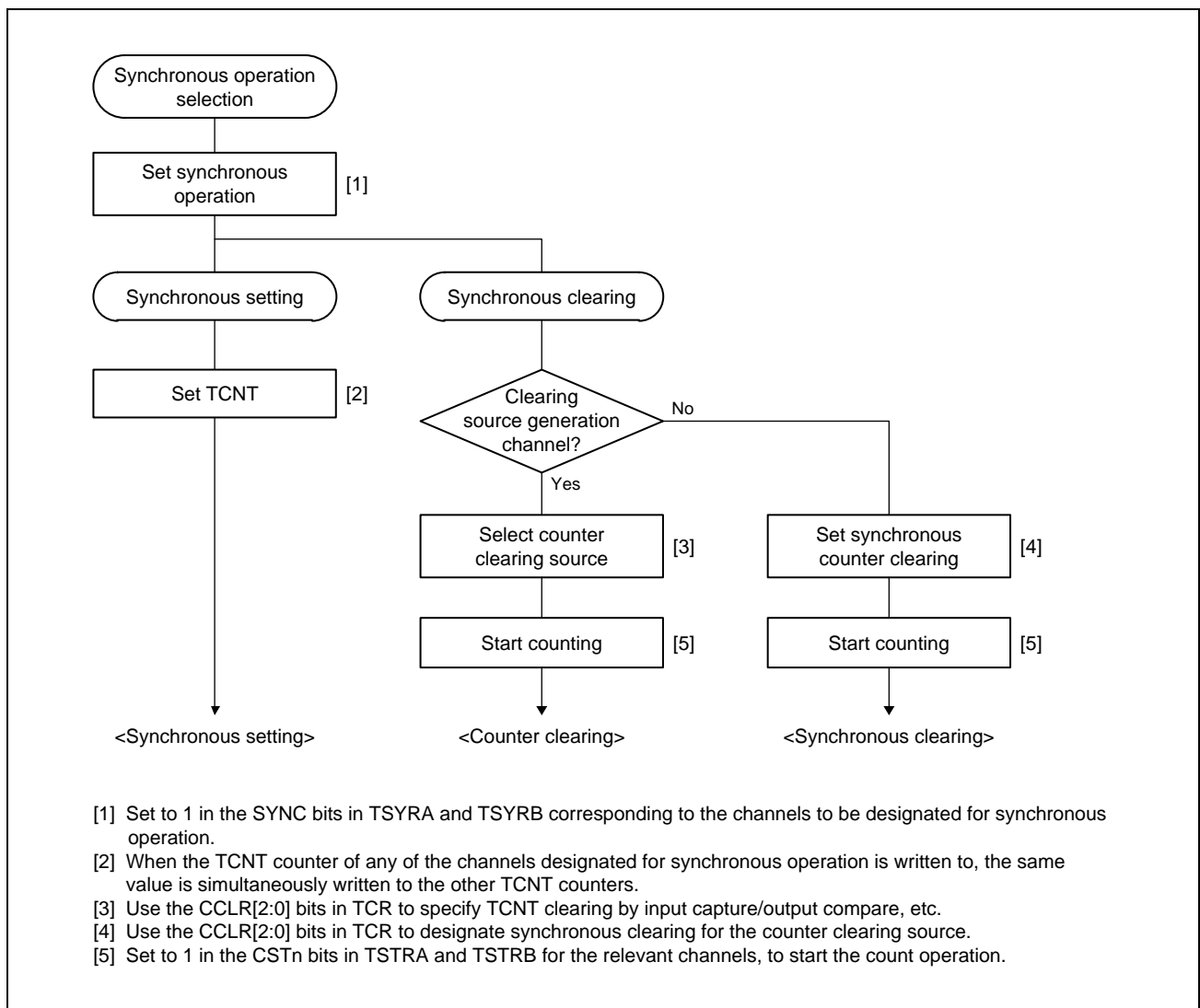

Figure 16.13 Example of Synchronous Operation Setting Procedure

(2) Example of Synchronous Operation

Figure 16.14 shows an example of synchronous operation.

In this example, synchronous operation and PWM mode 1 have been designated for MTU0 to MTU 2, MTU0.TGRB compare match has been set as the counter clearing source in MTU0, and synchronous clearing has been set for the counter clearing source in MTU1 and MTU2.

Three-phase PWM waveforms are output from pins MTIOC0A, MTIOC1A, and MTIOC2A. At this time, synchronous setting and synchronous clearing by MTU0.TGRB compare match are performed for the TCNT counters in MTU0 to MTU2, and the data set in MTU0.TGRB is used as the PWM cycle.

For details of PWM modes, see **Section 16.3.5, PWM Modes**.

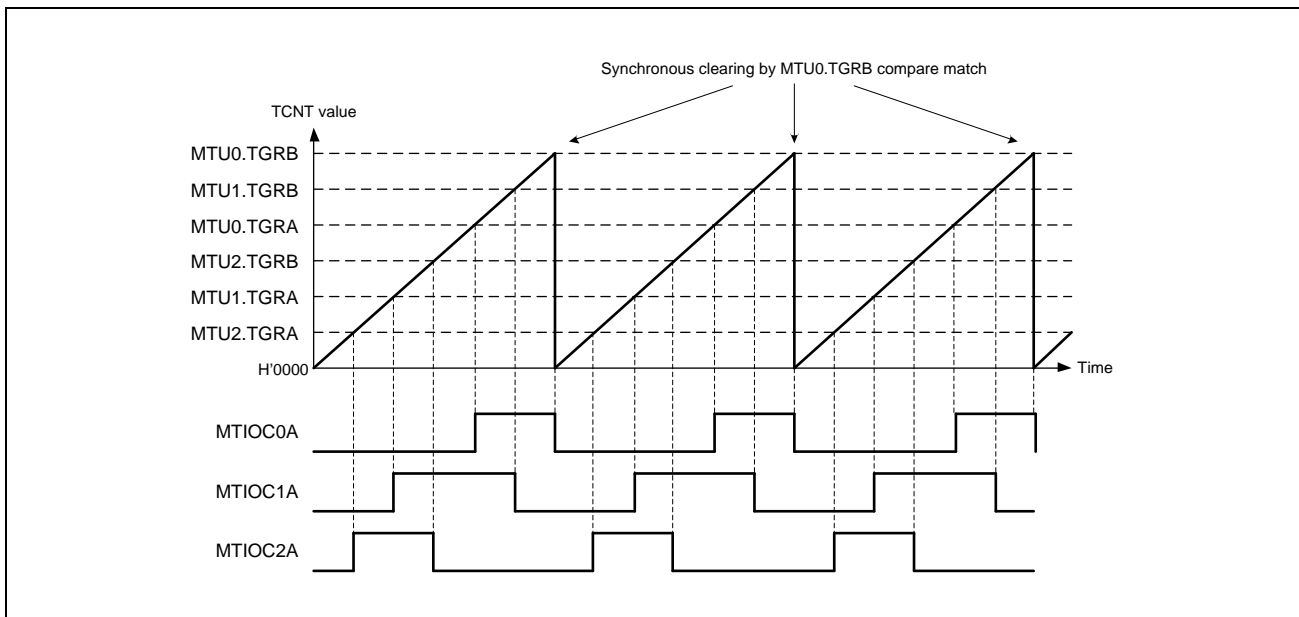

Figure 16.14 Example of Synchronous Operation

16.3.3 Buffer Operation

Buffer operation, provided for MTU0, MTU3, MTU4, MTU6, MTU7, and MTU8, enables TGRC and TGRD to be used as buffer registers. In MTU0, TGRF can also be used as a buffer register.

Buffer operation differs depending on whether TGR has been designated as an input capture register or as a compare match register.

NOTE

MTU0.TGRE cannot be designated as an input capture register and can only operate as a compare match register.

Table 16.62 shows the register combinations used in buffer operation.

Table 16.62 Register Combinations in Buffer Operation

Channel	Timer General Register	Buffer Register
MTU0	TGRA	TGRC
	TGRB	TGRD
	TGRE	TGRF
MTU3	TGRA	TGRC
	TGRB	TGRD
MTU4	TGRA	TGRC
	TGRB	TGRD
MTU6	TGRA	TGRC
	TGRB	TGRD
MTU7	TGRA	TGRC
	TGRB	TGRD
MTU8	TGRA	TGRC
	TGRB	TGRD

When TGR is an output compare register

When a compare match occurs, the value in the buffer register for the corresponding channel is transferred to the timer general register.

This operation is illustrated in **Figure 16.15**.

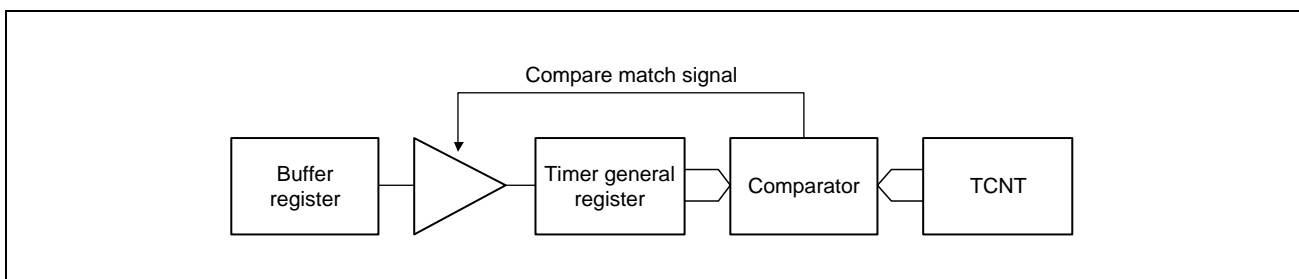

Figure 16.15 Compare Match Buffer Operation

When TGR is an input capture register

When an input capture occurs, the value in TCNT is transferred to TGR and the value previously held in TGR is transferred to the buffer register.

This operation is illustrated in **Figure 16.16**.

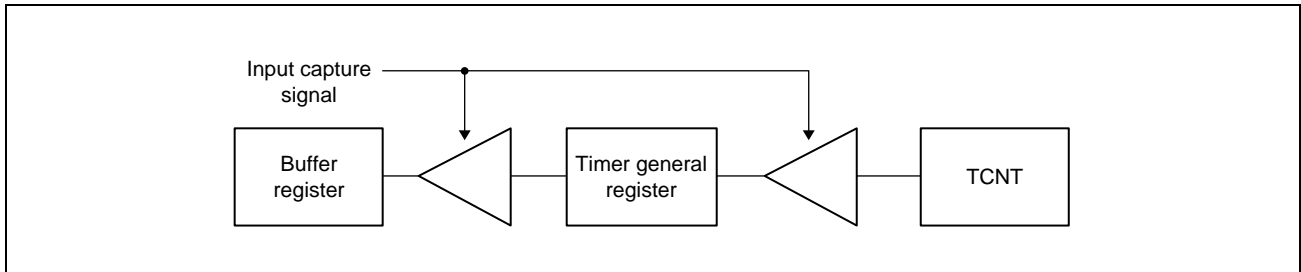

Figure 16.16 Input Capture Buffer Operation

(1) Example of Buffer Operation Setting Procedure

Figure 16.17 shows an example of the buffer operation setting procedure.

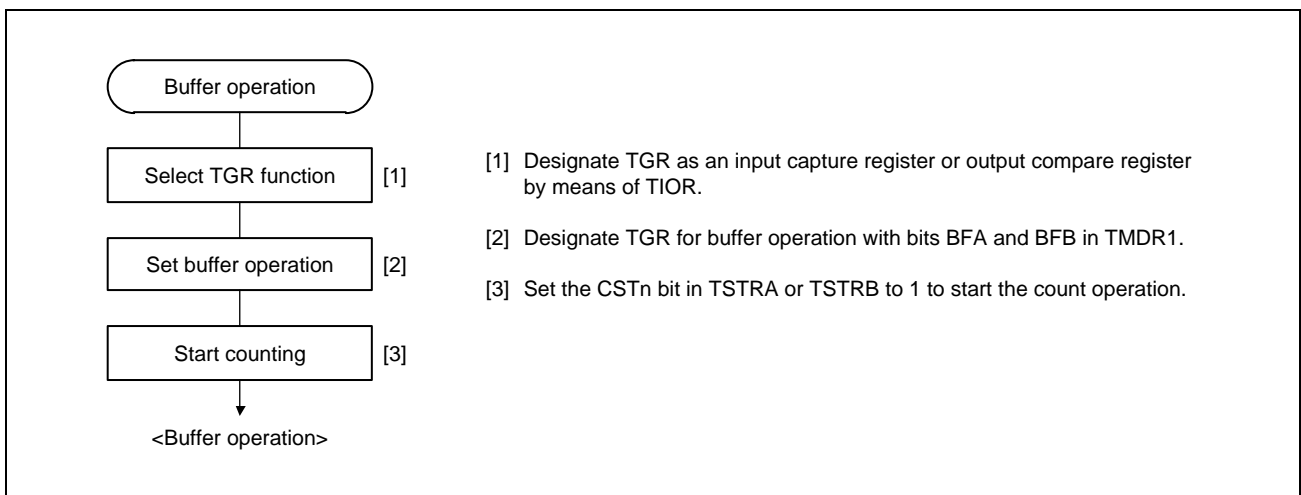

Figure 16.17 Example of Buffer Operation Setting Procedure

(2) Examples of Buffer Operation

(a) When TGR is an Output Compare Register

Figure 16.18 shows an operation example in which PWM mode 1 has been designated for MTU0, and buffer operation has been designated for TGRA and TGRC. The settings used in this example are TCNT clearing by compare match B, high output at compare match A, and low output at compare match B. In this example, the TTSA bit in TBTM is cleared to 0.

As buffer operation has been set, when compare match A occurs, the output changes and the value in buffer register TGRC is simultaneously transferred to timer general register TGRA. This operation is repeated each time compare match A occurs.

For details of PWM modes, see **Section 16.3.5, PWM Modes**.

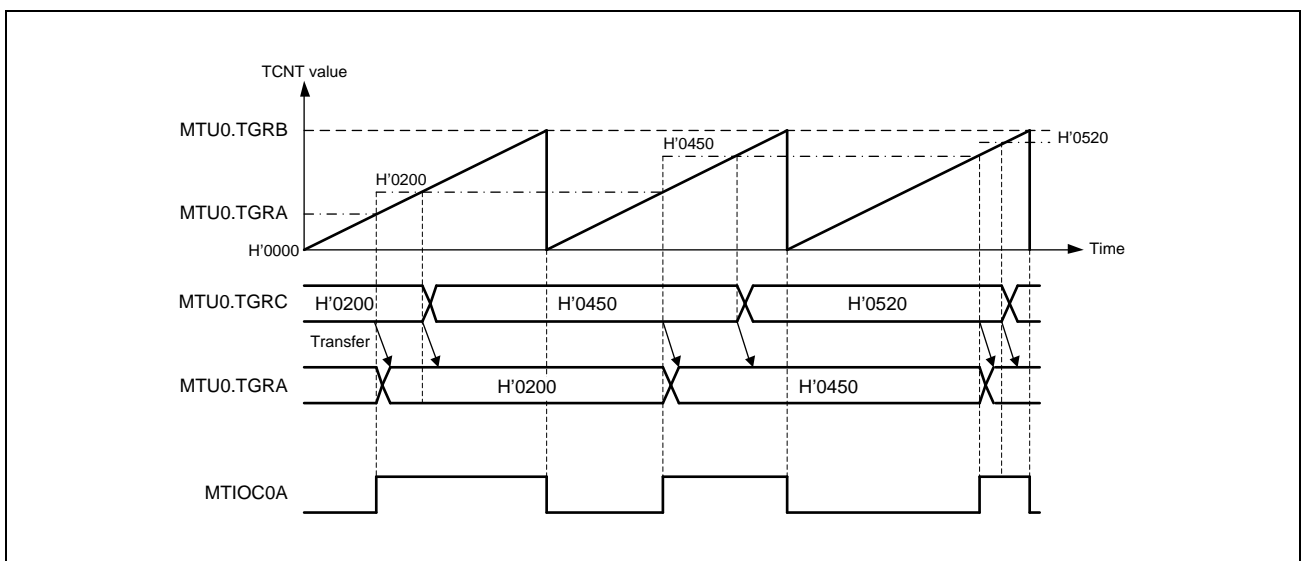

Figure 16.18 Example of Buffer Operation (1)

(b) When TGR is an Input Capture Register

Figure 16.19 shows an operation example in which TGRA has been designated as an input capture register, and buffer operation has been designated for TGRA and TGRC.

Counter clearing by TGRA input capture has been set for TCNT, and both rising and falling edges have been selected as the MTIOCnA pin input capture input edge. (n = 0 to 4, 6, 7, 8)

As buffer operation has been set, when the TCNT value is transferred to TGRA upon occurrence of input capture A, the value previously stored in TGRA is simultaneously transferred to TGRC.

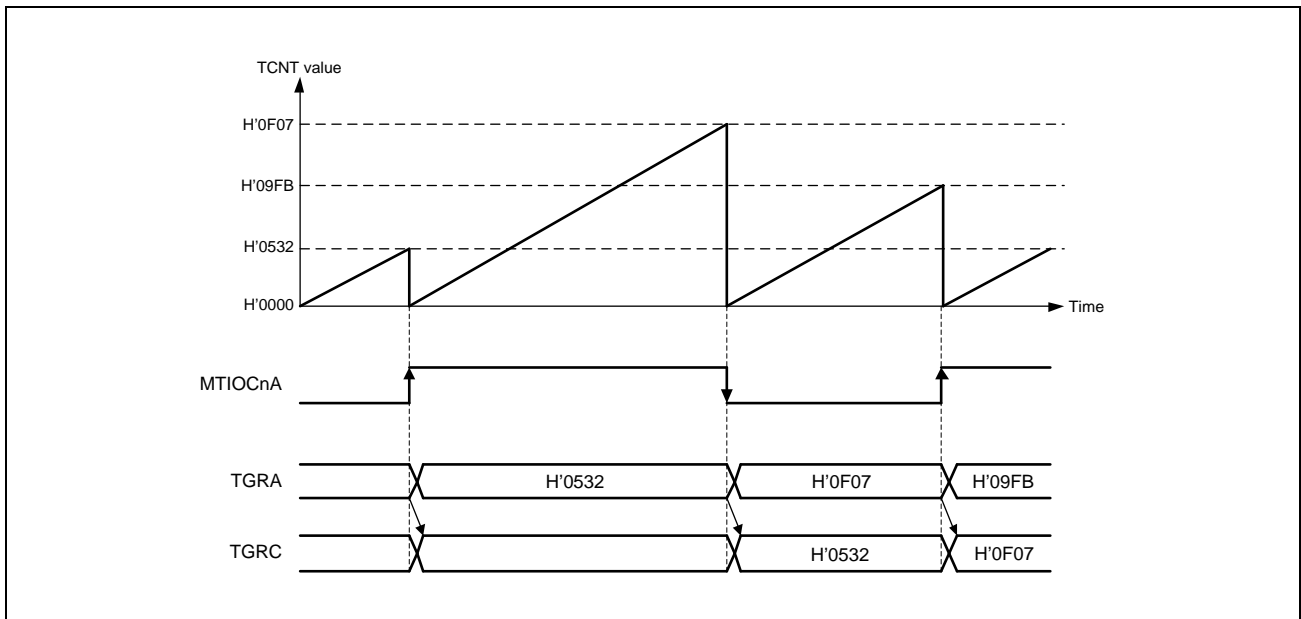

Figure 16.19 Example of Buffer Operation (2) (n = 0 to 4, 6, 7, 8)

(3) Selecting Timing for Transfer from Buffer Registers to Timer General Registers in Buffer Operation

The timing for transfer from buffer registers to timer general registers can be selected in PWM mode 1 or 2 for MTU0 or in PWM mode 1 for MTU3, MTU4, MTU6, and MTU7 by setting the buffer operation transfer mode registers (MTUn.TBTM (n = 0, 3, 4, 6, 7)). Either compare match (value after reset) or TCNT clearing can be selected for the transfer timing. TCNT clearing as transfer timing is one of the following cases.

- When TCNT overflows (H'FFFF to H'0000)
- When H'0000 is written to TCNT during counting
- When TCNT is cleared to H'0000 under the condition specified in the CCLR[2:0] bits in TCR

NOTE

TBTM must be modified only while TCNT stops.

Figure 16.20 shows an operation example in which PWM mode 1 is designated for MTU0 and buffer operation is designated for MTU0.TGRA and MTU0.TGRC. The settings used in this example are MTU0.TCNT clearing by compare match B, high output at compare match A, and low output at compare match B. The TTSA bit in MTU0.TBTM is set to 1.

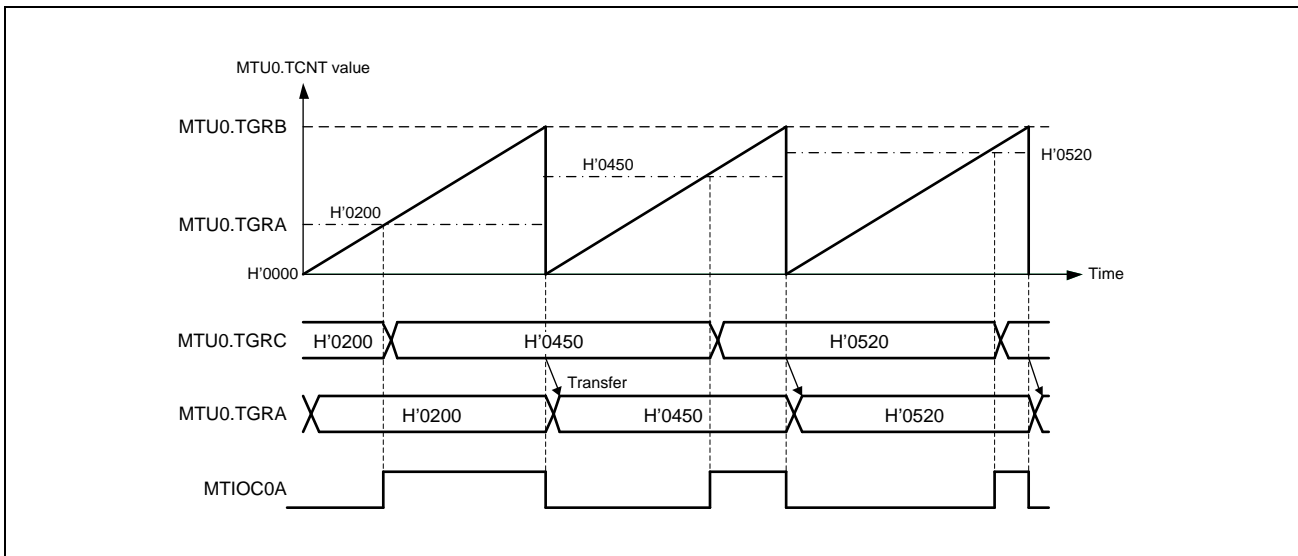

Figure 16.20 Example of Buffer Operation When MTU0.TCNT Clearing is Selected for MTU0.TGRC to MTU0.TGRA Transfer Timing

16.3.4 Cascaded Operation

In cascaded operation, two 16-bit counters in different channels are used together as a 32-bit counter.

There are two functions for connecting MTU1 and MTU2 to use as a 32-bit counter: cascade connection to be set when the MTU1.TMDR3.LWA bit is 0, and cascade connection 32-bit phase counting mode to be set when the MTU1.TMDR3.LWA bit is 1. For details on cascade connection 32-bit phase counting mode, refer to **Section 16.3.6.2, Cascade Connection 32-Bit Phase Counting Mode**. This section describes the cascade connection function to be set when the MTU1.TMDR3.LWA bit is 0.

This function works when the LWA bit of TMDR3 in MTU1 is set to 0 and the TPSC[2:0] bits of TCR in MTU1 are set so that TCNT in MTU1 counts at an overflow/underflow of TCNT in MTU2.

Underflow occurs only when the MTU2 to which the lower 16 bits allocated is in phase counting mode.

Table 16.63 shows the register combinations used in cascaded operation.

NOTE

When phase counting mode is set for MTU1, the count clock setting is invalid and the counters operate independently in phase counting mode.

Table 16.63 Cascaded Combinations

Combination	Upper 16 Bits	Lower 16 Bits
MTU1 and MTU2	MTU1.TCNT	MTU2.TCNT

For simultaneous input capture of MTU1.TCNT and MTU2.TCNT during cascaded operation, additional input capture input pins can be specified by the input capture control register (TICCR). The input-capture condition is of edges in the signal produced by taking the logical OR of the input level on the main input pin and the input level on the added input pin. Accordingly, if either is at the high level, a change in the level of the other will not produce an edge for detection. For details, see **Section 16.3.4(4), Cascaded Operation Example (c)**. For input capture in cascade connection, refer to **Section 16.6.20, Simultaneous Input Capture in MTU1.TCNT and MTU2.TCNT in Cascade Connection**.

Table 16.64 shows the TICCR setting and input capture input pins.

Table 16.64 TICCR Setting and Input Capture Input Pins

Target Input Capture	TICCR Setting	Input Capture Input Pin
Input capture from MTU1.TCNT to MTU1.TGRA	I2AE bit = 0 (Initial value)	MTIOC1A
	I2AE bit = 1	MTIOC1A, MTIOC2A
Input capture from MTU1.TCNT to MTU1.TGRB	I2BE bit = 0 (Initial value)	MTIOC1B
	I2BE bit = 1	MTIOC1B, MTIOC2B
Input capture from MTU2.TCNT to MTU2.TGRA	I1AE bit = 0 (Initial value)	MTIOC2A
	I1AE bit = 1	MTIOC2A, MTIOC1A
Input capture from MTU2.TCNT to MTU2.TGRB	I1BE bit = 0 (Initial value)	MTIOC2B
	I1BE bit = 1	MTIOC2B, MTIOC1B

(1) Example of Cascaded Operation Setting Procedure

Figure 16.21 shows an example of the cascaded operation setting procedure.

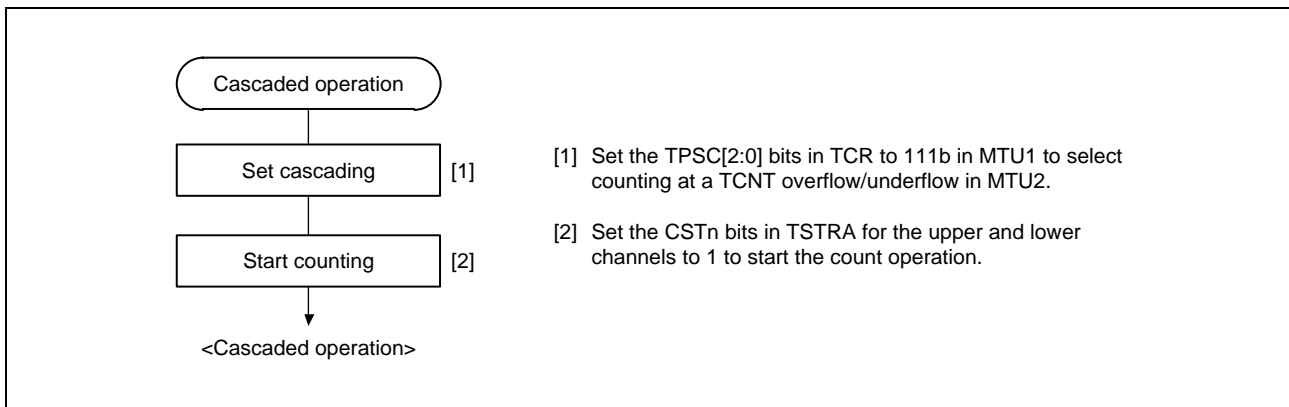

Figure 16.21 Cascaded Operation Setting Procedure

(2) Cascaded Operation Example (a)

Figure 16.22 shows the operation when MTU1.TCNT is set for counting at MTU2.TCNT overflow/underflow and MTU2 is set for phase counting mode 1 while MTU1.TCNT and MTU2.TCNT are cascaded.

MTU1.TCNT is incremented by MTU2.TCNT overflow and decremented by MTU2.TCNT underflow.

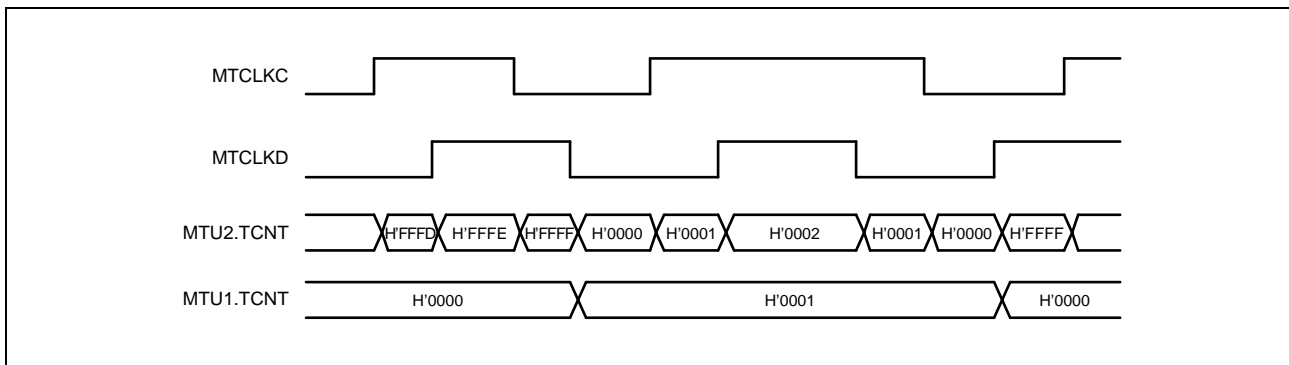

Figure 16.22 Cascaded Operation Example (a)

(3) Cascaded Operation Example (b)

Figure 16.23 illustrates the operation when MTU1.TCNT and MTU2.TCNT have been cascaded and the I2AE bit in TICCR has been set to 1 to include the MTIOC2A pin in the MTU1.TGRA input capture conditions. In this example, the MTU1.TIOR.IOA[3:0] bits have selected the MTIOC1A rising edge for the input capture timing while the MTU2.TIOR.IOA[3:0] bits have selected the MTIOC2A rising edge for the input capture timing.

Under these conditions, the rising edge of both MTIOC1A and MTIOC2A is used for the MTU1.TGRA input capture condition. For the MTU2.TGRA input capture condition, the MTIOC2A rising edge is used.

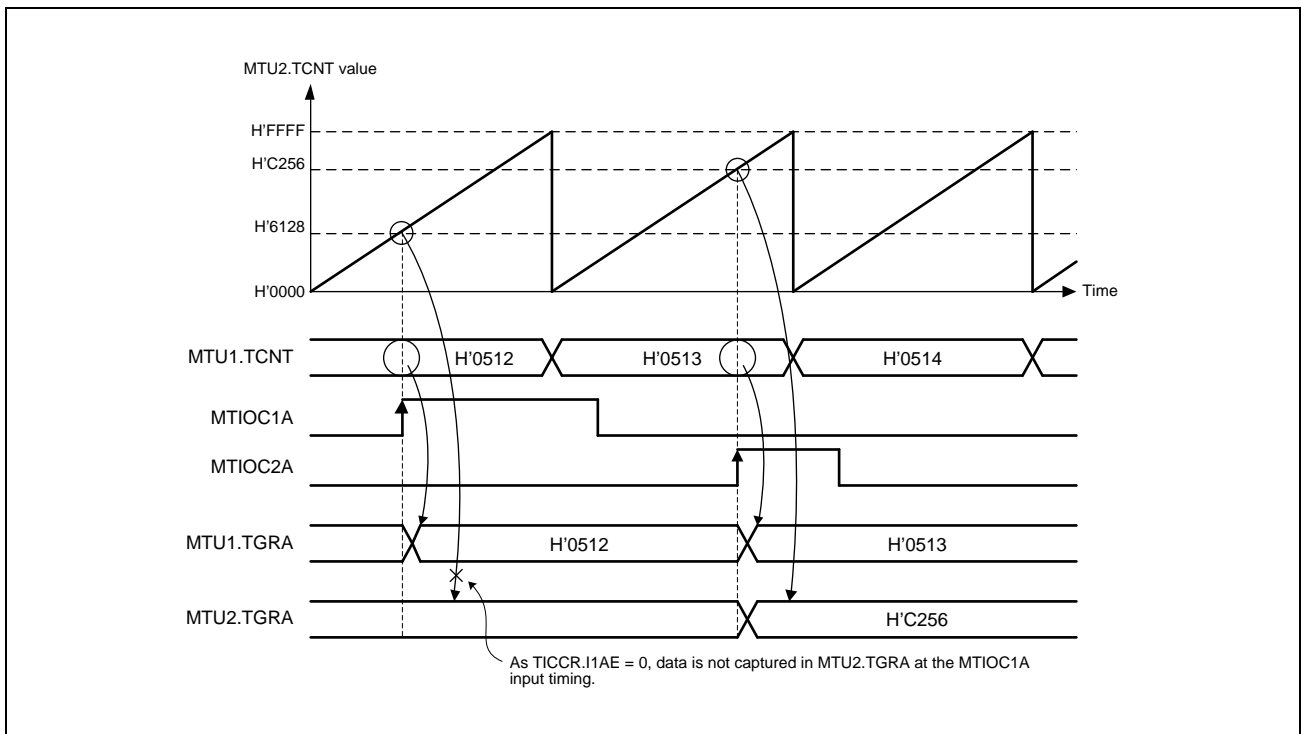

Figure 16.23 Cascaded Operation Example (b)

(4) Cascaded Operation Example (c)

Figure 16.24 illustrates the operation when MTU1.TCNT and MTU2.TCNT have been cascaded and the TICCR.I2AE and I1AE bits have been set to 1 to include the MTIOC2A and MTIOC1A pins in the MTU1.TGRA and MTU2.TGRA input capture conditions, respectively. In this example, the IOA[3:0] bits in both MTU1.TIOR and MTU2.TIOR have selected both the rising and falling edges for the input capture timing. Under these conditions, the ORed result of MTIOC1A and MTIOC2A input is used for the MTU1.TGRA and MTU2.TGRA input capture conditions.

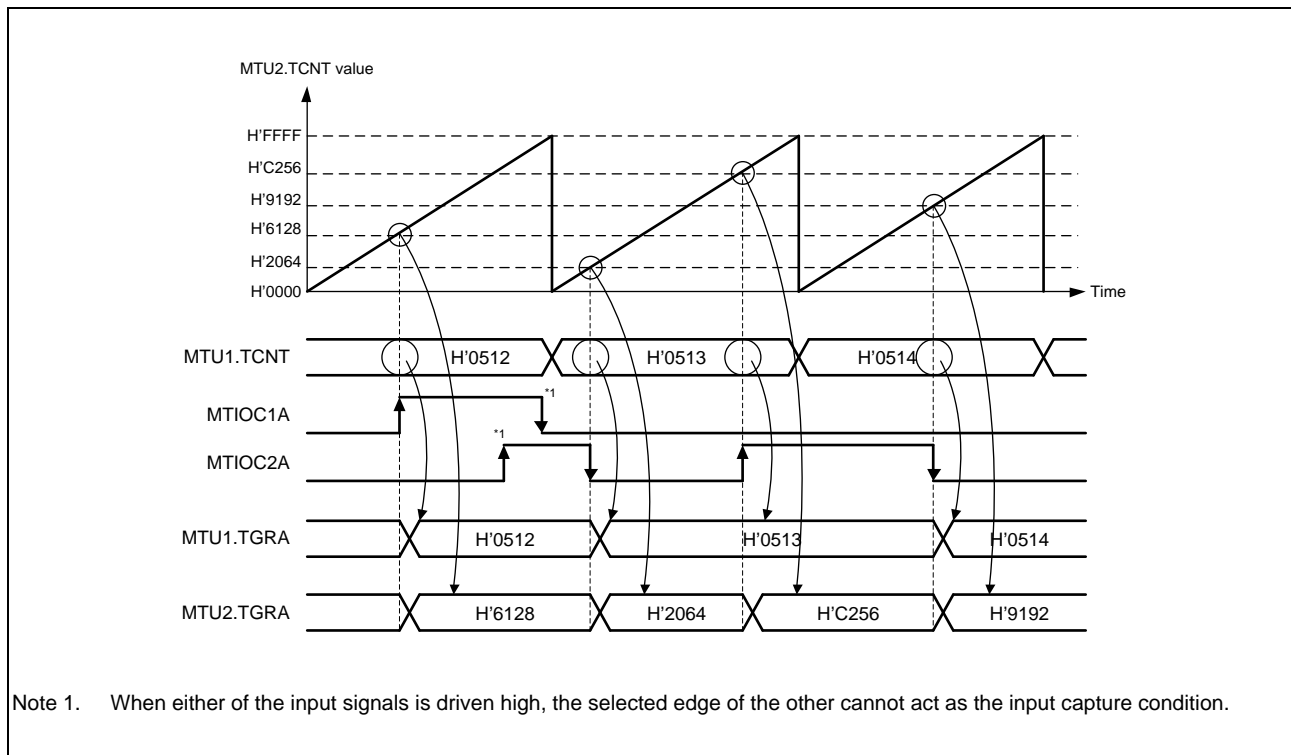

Figure 16.24 Cascaded Operation Example (c)

(5) Cascaded Operation Example (d)

Figure 16.25 illustrates the operation when MTU1.TCNT and MTU2.TCNT have been cascaded and the TICCR.I2AE bit has been set to 1 to include the MTIOC2A pin in the MTU1.TGRA input capture conditions. In this example, the IOA[3:0] bits in MTU1.TIOR have selected occurrence of MTU0.TGRA compare match or input capture for the input capture timing while the IOA[3:0] bits in MTU2.TIOR have selected the MTIOC2A rising edge for the input capture timing.

Under these conditions, as MTU1.TIOR has selected occurrence of MTU0.TGRA compare match or input capture for the input capture timing, the MTIOC2A edge is not used for MTU1.TGRA input capture condition although the I2AE bit in TICCR has been set to 1.

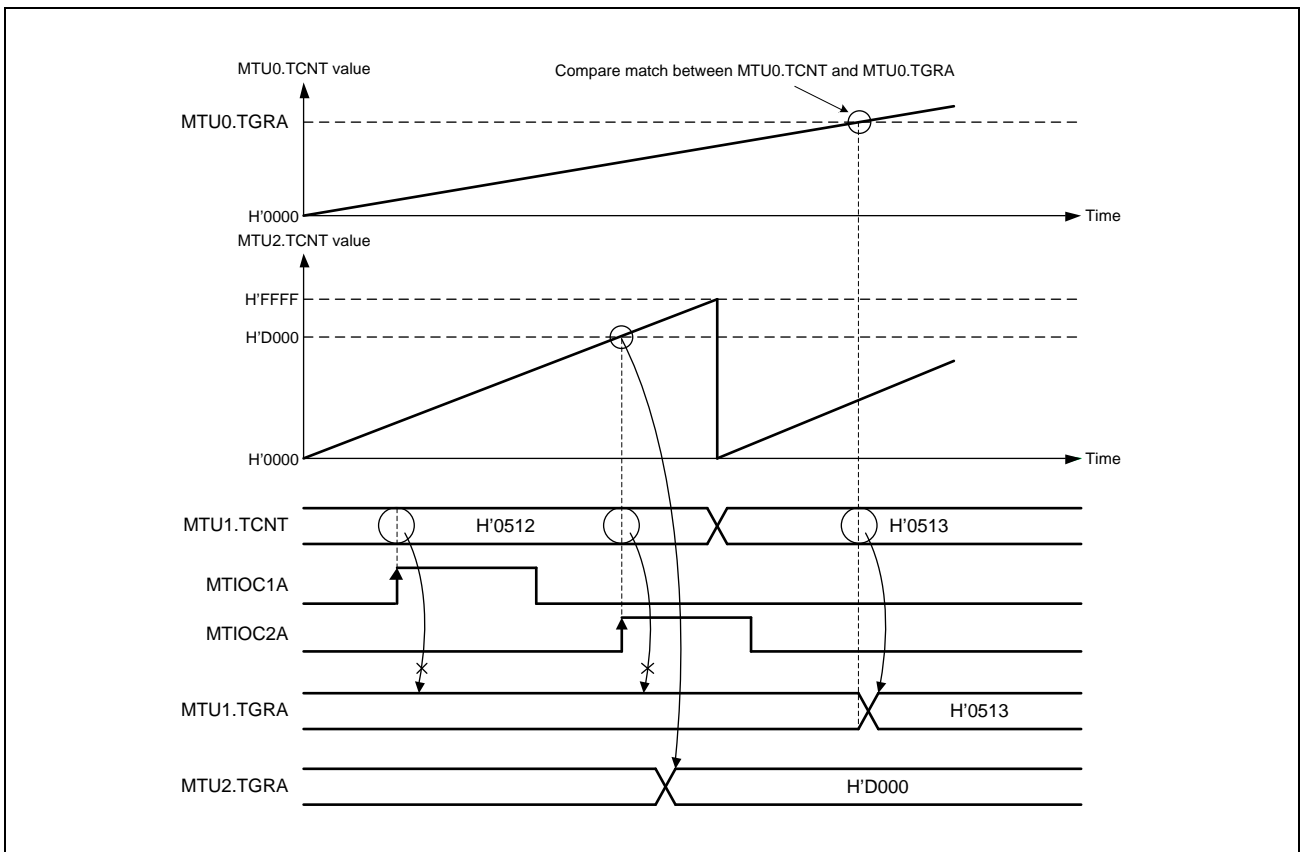

Figure 16.25 Cascaded Operation Example (d)

16.3.5 PWM Modes

PWM modes are provided to output PWM waveforms from the external pins. The output level can be selected as low, high, or toggle output in response to a compare match of each TGR.

PWM waveforms in the range of 0% to 100% duty cycle can be output according to the TGR settings.

By designating TGR compare match as the counter clearing source, the PWM cycle can be specified in that register. Every channel except MTU5 and MTU8 can be set to PWM mode independently. Synchronous operation is also possible between the channels placed in PWM mode or between a channel in PWM mode and another channel in a different mode.

There are two PWM modes as described below.

PWM Mode 1

PWM waveforms are output from the MTIOCnA and MTIOCnC pins by pairing TGRA with TGRB and TGRC with TGRD. The levels specified by the TIOR.IOA[3:0] and IOC[3:0] bits are output from the MTIOCnA and MTIOCnC pins at compare matches A and C, and the level specified by the TIOR.IOB[3:0] and IOD[3:0] bits are output at compare matches B and D (n = 0 to 4, 6, 7). The initial output value is set in TGRA or TGRC. If the values set in paired TGRs are identical, the output value does not change even when a compare match occurs.

In PWM mode 1, PWM waveforms in up to 12 phases can be output.

PWM Mode 2

PWM waveform output is generated using one TGR as the cycle register and the others as duty registers. The level specified in TIOR is output at compare matches. Upon counter clearing by a cycle register compare match, the initial value set in TIOR is output from each pin. If the values set in the cycle and duty registers are identical, the output value does not change even when a compare match occurs.

In PWM mode 2, up to eight phases of PWM waveforms can be output when synchronous clearing is used as synchronous operation in the channels that cannot be placed in PWM mode 2.

The correspondence between PWM output pins and registers is shown in **Table 16.65**.

Table 16.65 PWM Output Registers and Output Pins

Channel	Register	Output Pins	
		PWM Mode 1	PWM Mode 2
MTU0	TGRA	MTIOC0A	MTIOC0A
	TGRB		MTIOC0B
	TGRC	MTIOC0C	MTIOC0C
	TGRD		MTIOC0D
MTU1	TGRA	MTIOC1A	MTIOC1A
	TGRB		MTIOC1B
MTU2	TGRA	MTIOC2A	MTIOC2A
	TGRB		MTIOC2B
MTU3	TGRA	MTIOC3A	Setting prohibited
	TGRB		
	TGRC	MTIOC3C	
	TGRD		
MTU4	TGRA	MTIOC4A	
	TGRB		
	TGRC	MTIOC4C	
	TGRD		
MTU6	TGRA	MTIOC6A	
	TGRB		
	TGRC	MTIOC6C	
	TGRD		
MTU7	TGRA	MTIOC7A	
	TGRB		
	TGRC	MTIOC7C	
	TGRD		

Note: In PWM mode 2, PWM waveform output is not possible for the TGR register in which the PWM cycle is set.

(1) Example of PWM Mode Setting Procedure

Figure 16.26 shows an example of the PWM mode setting procedure.

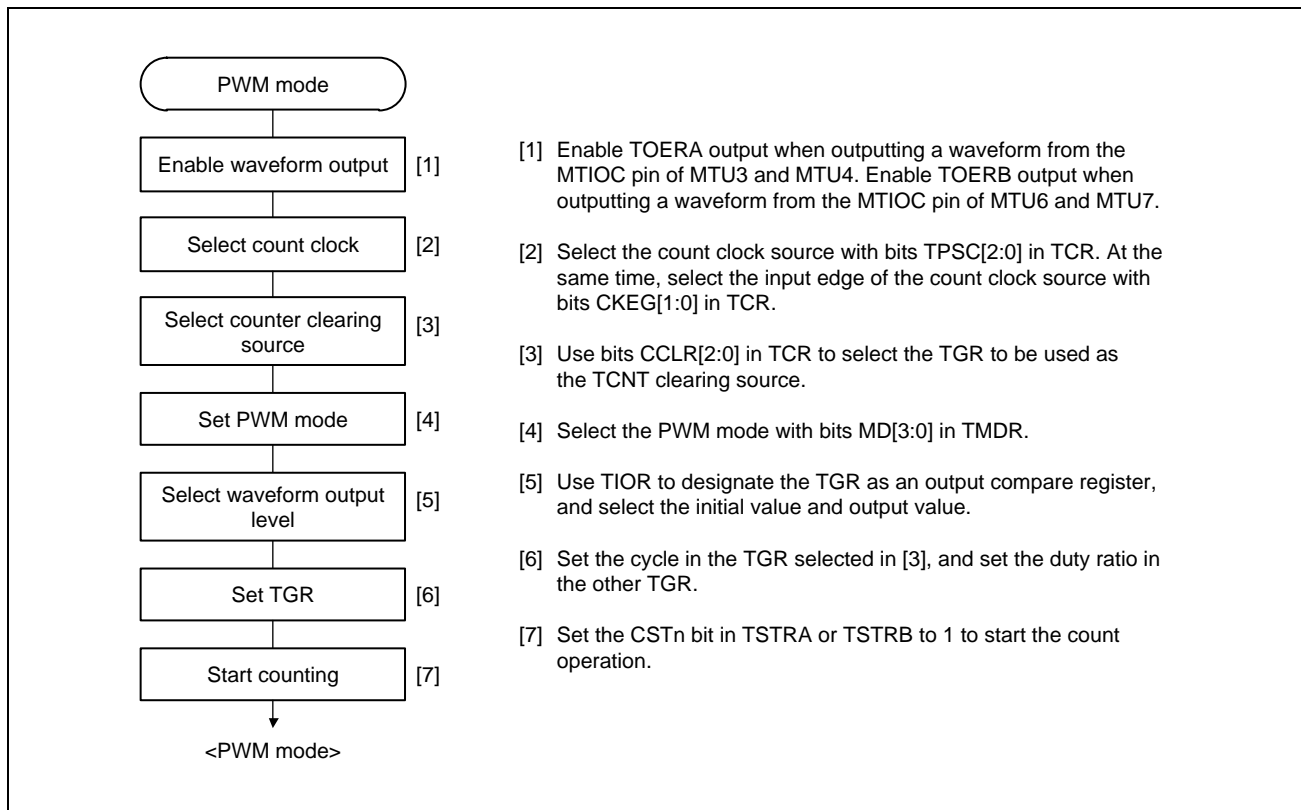

Figure 16.26 Example of PWM Mode Setting Procedure

(2) Examples of PWM Mode Operation

Figure 16.27 shows an example of operation in PWM mode 1.

In this example, TGRA compare match is set as the TCNT clearing source, 0 is set as the initial output value and output value for TGRA, and 1 is set as the output value for TGRB.

In this case, the value set in TGRA is used as the cycle, and the value set in TGRB is used as the duty ratio.

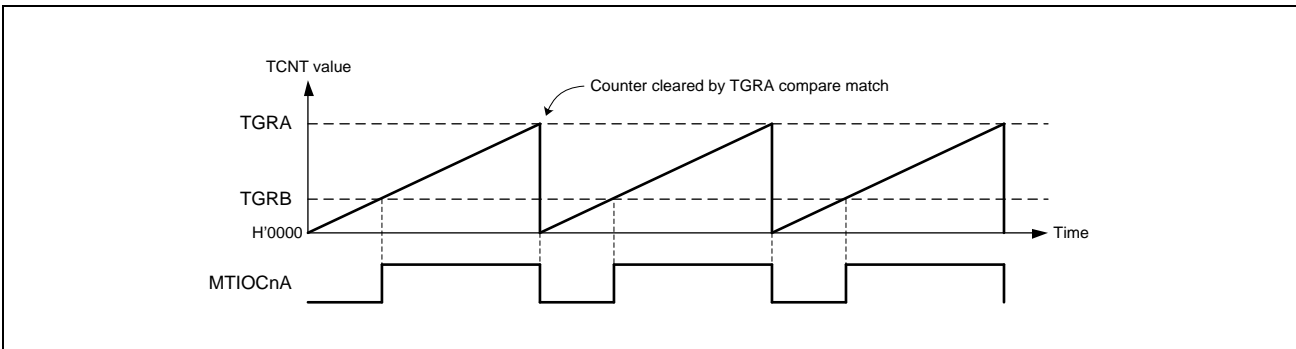

Figure 16.27 Example of PWM Mode 1 Operation (n = 0 to 4, 6, 7)

Figure 16.28 shows an example of operation in PWM mode 2.

In this example, synchronous operation is designated for MTU0 and MTU1, MTU1.TGRB compare match is set as the TCNT clearing source, and low is set as the initial output value and high as the output value for the other TGR registers (MTU0.TGRA to MTU0.TGRD and MTU1.TGRA), outputting 5-phase PWM waveforms.

In this case, the value set in MTU1.TGRB is used as the cycle, and the values set in the other TGRs are used as the duty ratio.

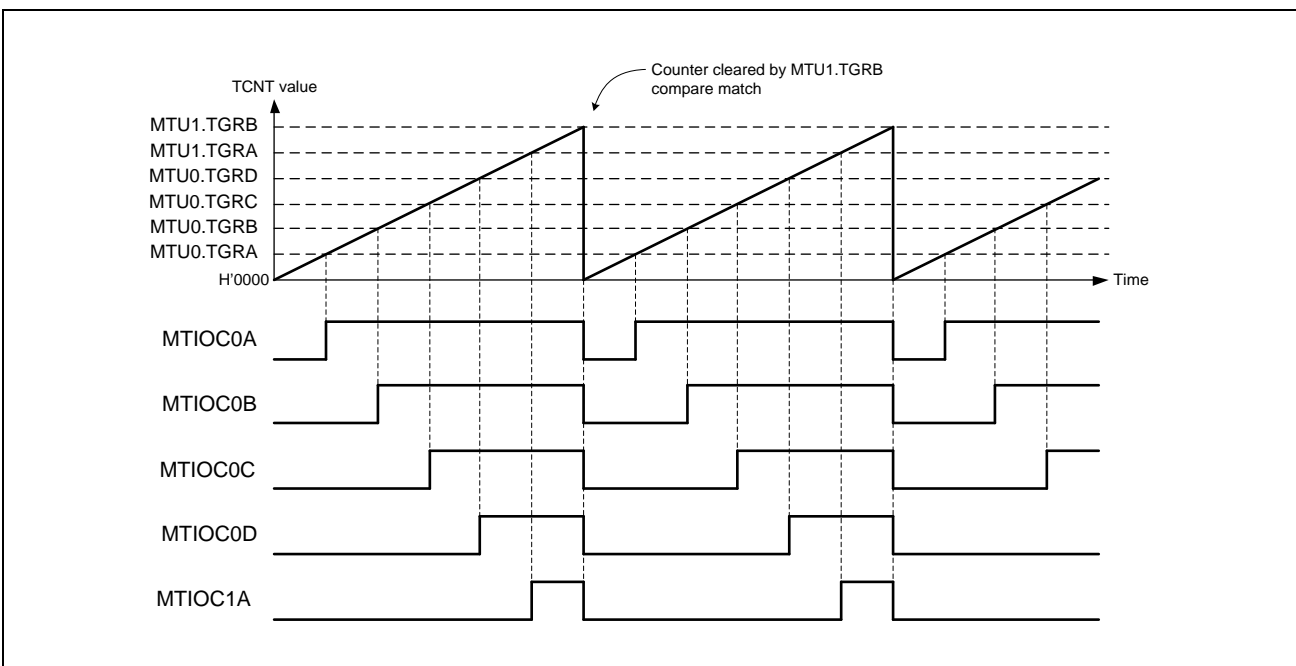

Figure 16.28 Example of PWM Mode 2 Operation

Figure 16.29 shows examples of PWM waveform output with 0% duty and 100% duty in PWM mode 1. In these examples, TGRA compare match is selected as the TCNT clearing source, the initial output value and the output value for TGRA are set to the low level, and the output value for TGRB is set to the high level.

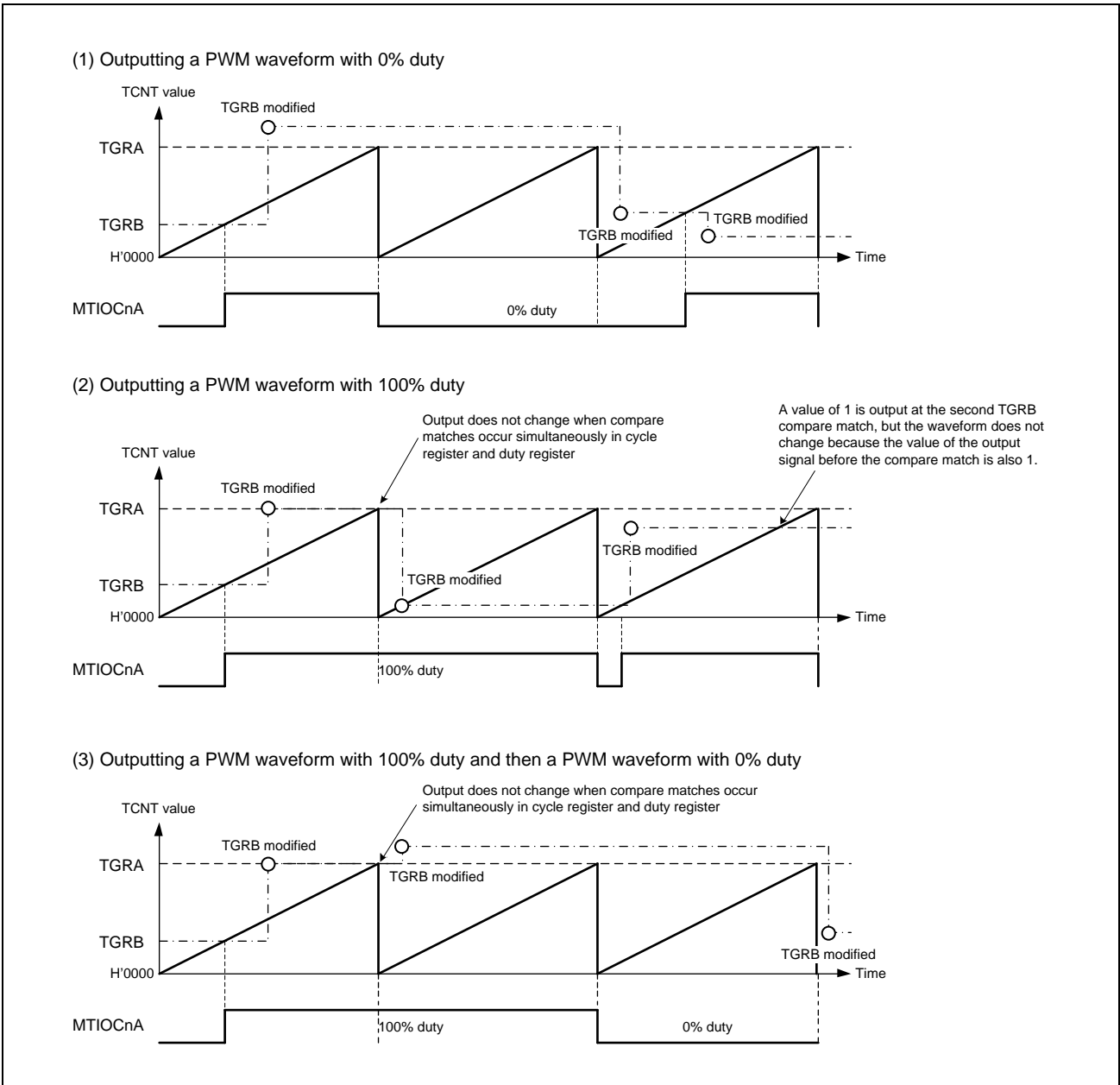

Figure 16.29 Examples of PWM Mode Operation (PWM Waveform Output with 0% Duty and 100% Duty) (n = 0 to 4, 6, 7)

16.3.6 Phase Counting Mode

There are two phase counting modes: 16-bit phase counting mode in which MTU1 and MTU2 operate independently, and cascade connection 32-bit phase counting mode in which MTU1 and MTU2 are cascaded.

In phase counting mode, the phase difference between two external input clocks is detected and the corresponding TCNT is incremented or decremented.

Two external clock input pins for each phase counting mode are not affected by the settings of TCR.TPSC[2:0], TCR2.TPSC2[2:0], and CKEG[1:0]. The two external clock input pins used in 16-bit phase counting mode and cascade connection 32-bit phase counting mode of MTU2 can be selected by MTU1.TMDR3.PHCKSEL. In a phase counting mode other than 16-bit phase counting mode and cascade connection 32-bit phase counting mode of MTU2, MTCLKA and MTCLKB are selected for A-phase and B-phase, respectively. In phase counting mode, the external clock pins MTCLKA, MTCLKB, MTCLKC, and MTCLKD are used for two-phase encoder pulse input.

Table 16.66 lists the external clock input pins to be connected in each phase counting mode.

Table 16.66 Clock Input Pins in Phase Counting Mode

Phase Counting Mode	TMDR3.PHCKSEL bit	External Clock Input Pins	
		A-Phase	B-Phase
MTU1 16-bit phase counting mode	x (Don't care)	MTCLKA	MTCLKB
MTU2 16-bit phase counting mode	0	MTCLKA	MTCLKB
	1 (initial value)	MTCLKC	MTCLKD
Cascade connection 32-bit phase counting mode	0	MTCLKA	MTCLKB
	1 (initial value)	MTCLKC	MTCLKD

16.3.6.1 16-Bit Phase Counting Mode

When the MTU1.TMDR3.LWA is 0, 16-bit phase counting mode can be set individually for MTU1 and MTU2.

In 16-bit phase counting mode, the phase difference between two external input clocks is detected and the 16-bit counter TCNT of the corresponding channel is incremented or decremented.

When 16-bit phase counting mode is specified, an external clock is selected as the count clock and TCNT operates as an up-counter/down-counter regardless of the setting of TCR.TPSC[2:0], TCR2.TPSC2[2:0], and CKEG[1:0]. However, the functions of TCR.CCLR[1:0], TIOR, TIER, and TGR are enabled, and input capture/compare match and interrupt functions can be used.

These external input pins can be used for two-phase encoder pulse input.

If an overflow occurs during TCNT up-counting, a TCIV interrupt is generated when the corresponding TCIEV bit in the TIER register is set to 1.

If an underflow occurs during TCNT down-counting, a TCIU interrupt is generated when the corresponding TCIEU bit in the TIER register is set to 1.

The TCFD bit in TSR is the count direction flag. Read the TCFD flag to check whether TCNT is counting up or down.

(1) Example of 16-Bit Phase Counting Mode Setting Procedure

Figure 16.30 shows an example of the phase counting mode setting procedure.

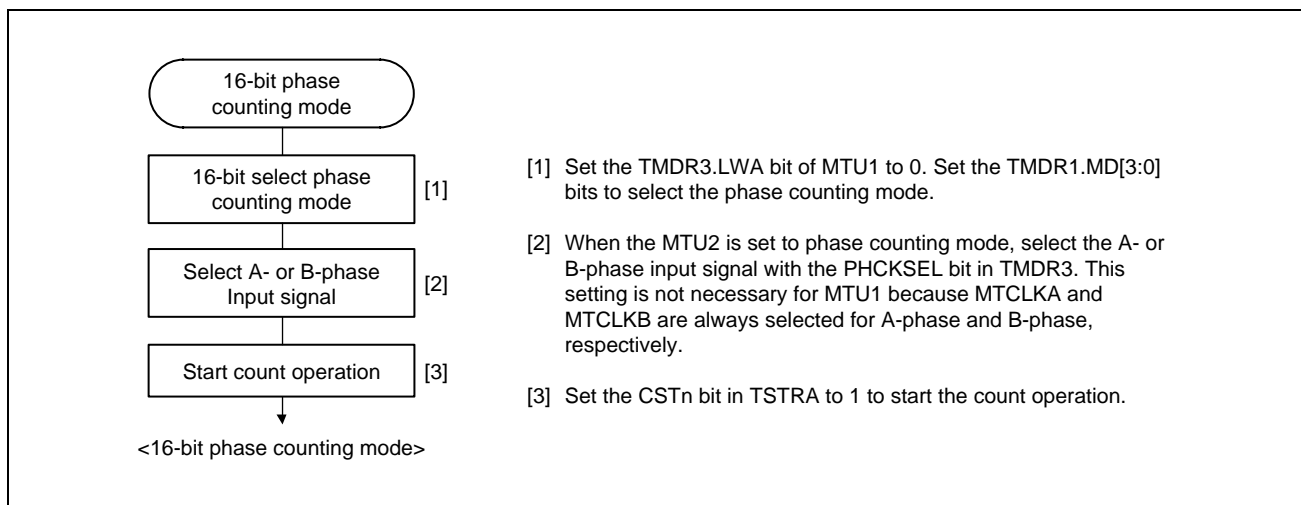

Figure 16.30 Example of 16-Bit Phase Counting Mode Setting Procedure

(2) Examples of 16-Bit Phase Counting Mode Operation

In phase counting mode, TCNT is incremented or decremented according to the phase difference between two external clocks. There are five modes according to the count conditions. Each mode operates under the condition PHCKSEL = 1, which means the phase clock for MTU1 is input from MTCLKA or MTCLKB and that for MTU2 is input from MTCLKC or MTCLKD.

(a) Phase Counting Mode 1

Figure 16.31 shows an example of operation in phase counting mode 1, and **Table 16.67** summarizes the TCNT up- counting and down-counting conditions.

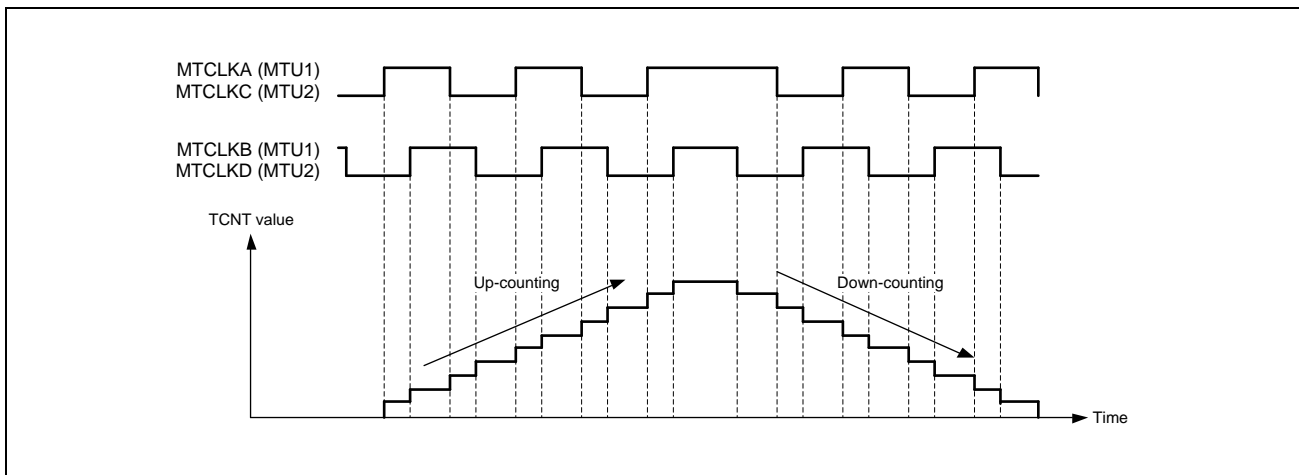

Figure 16.31 Example of Operation in Phase Counting Mode 1

Table 16.67 Up-Counting and Down-Counting Conditions in Phase Counting Mode 1

MTCLKA (MTU1) MTCLKC (MTU2)	MTCLKB (MTU1) MTCLKD (MTU2)	Operation
High		Up-counting
Low		
	Low	Down-counting
	High	
High		Down-counting
Low		
	High	Down-counting
	Low	

Remarks: : Rising edge
 : Falling edge

(b) Phase Counting Mode 2

Figure 16.32 to Figure 16.34 show the examples of operation in phase counting mode 2 and Table 16.68 summarizes the TCNT up-counting and down-counting conditions.

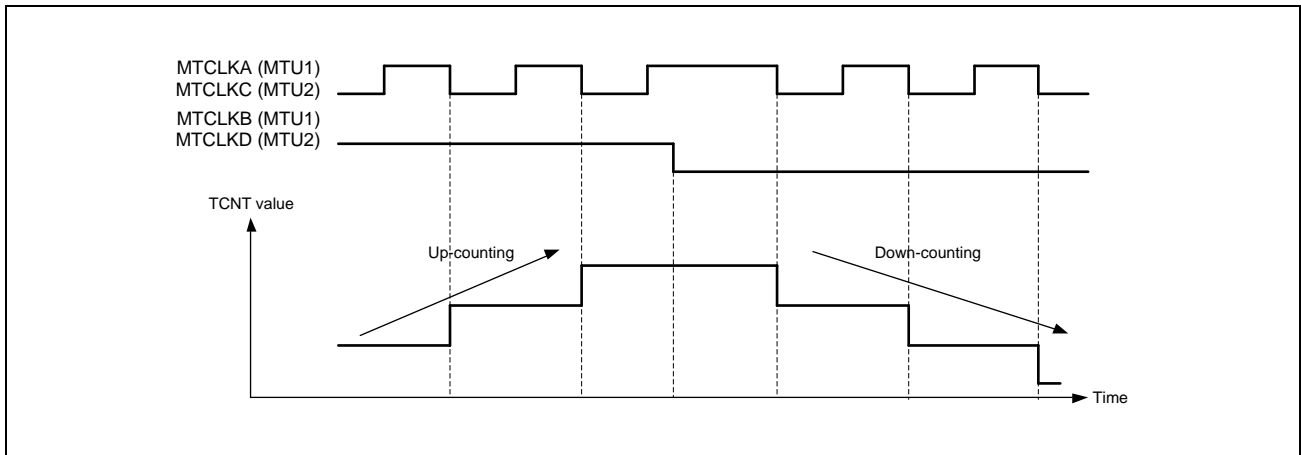

Figure 16.32 Example of Operation in Phase Counting Mode 2 (When MTUn.TCR2.PCB[1:0] is 00b (n = 1, 2))

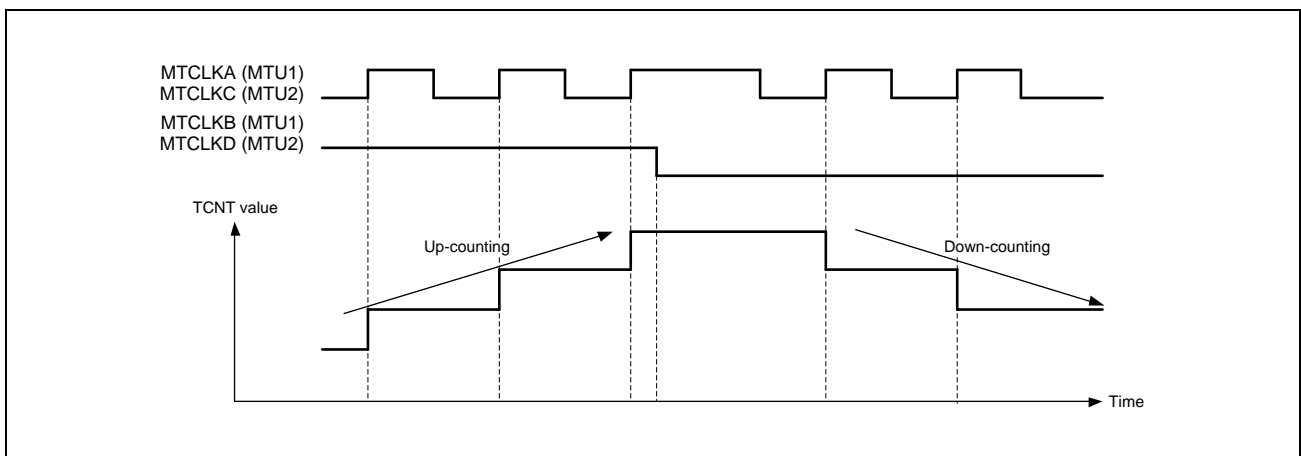

Figure 16.33 Example of Operation in Phase Counting Mode 2 (When MTUn.TCR2.PCB[1:0] is 01b (n = 1, 2))

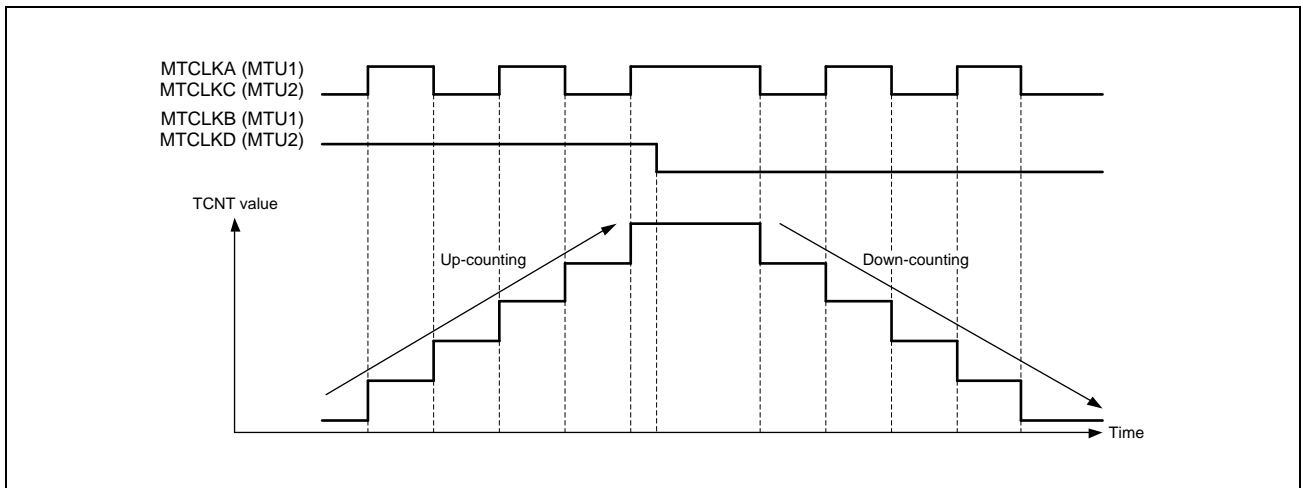

Figure 16.34 Example of Operation in Phase Counting Mode 2 (When MTUn.TCR2.PCB[1:0] is 1xb (n = 1, 2))

Table 16.68 Up-Counting and Down-Counting Conditions in Phase Counting Mode 2

PCB[1:0]	MTCLKA (MTU1) MTCLKC (MTU2)	MTCLKB (MTU1) MTCLKD (MTU2)	Operation
00b	High		Not counted (Don't care)
	Low		
		Low	Up-counting
		High	
	High		
	Low		
01b		High	Down-counting
		Low	
	High		Not counted (Don't care)
	Low		
		High	
		Low	
1xb		High	Up-counting
		Low	
	High		Not counted (Don't care)
	Low		
		High	
		Low	

Remarks: : Rising edge
 : Falling edge

(c) Phase Counting Mode 3

Figure 16.35 to Figure 16.37 show the examples of operation in phase counting mode 3 and Table 16.69 summarizes the TCNT up-counting and down-counting conditions.

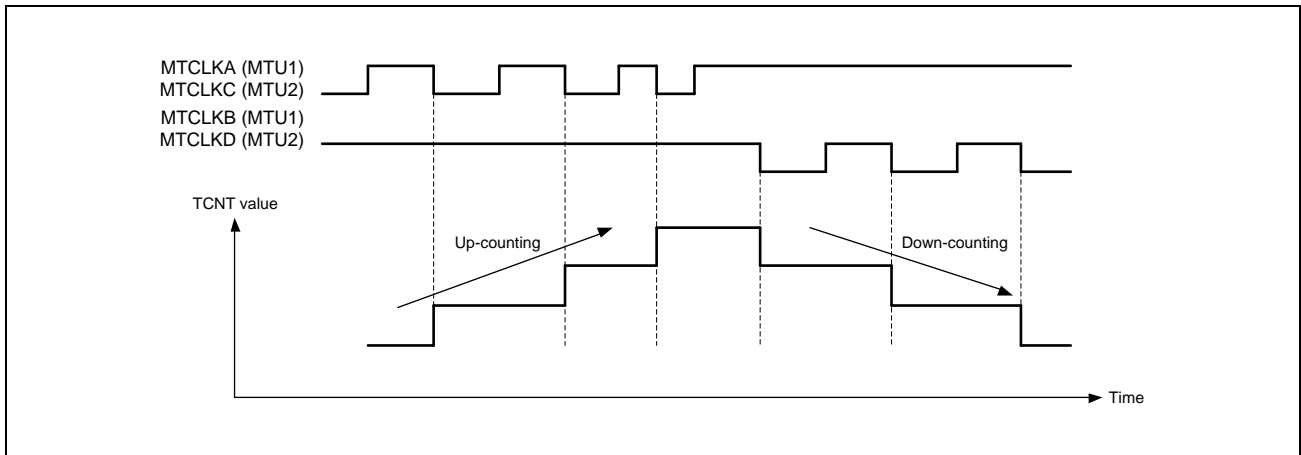

Figure 16.35 Example of Operation in Phase Counting Mode 3 (When MTUn.TCR2.PCB[1:0] is 00b (n = 1, 2))

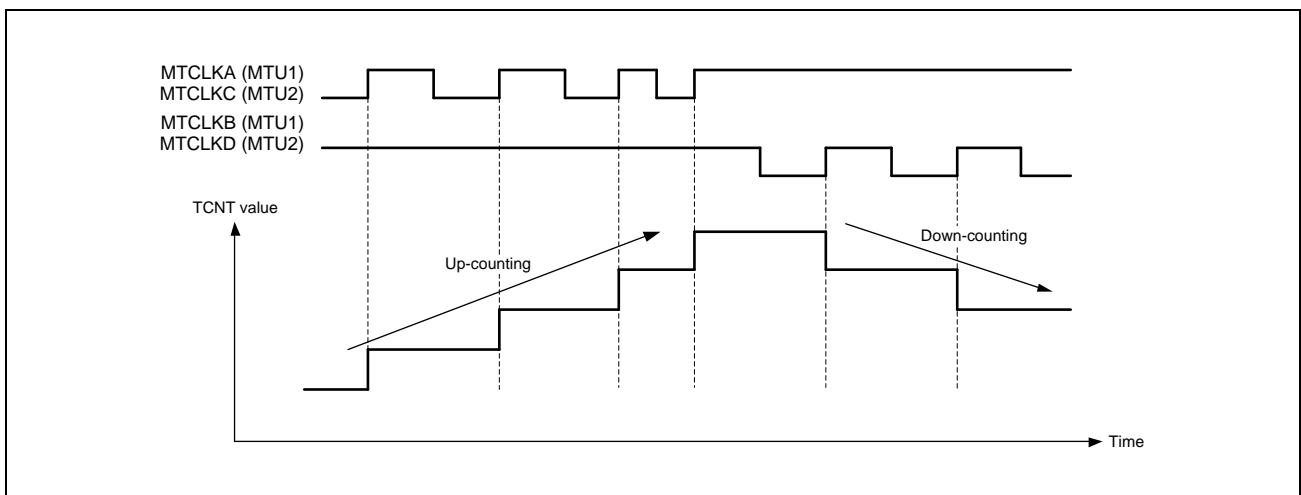

Figure 16.36 Example of Operation in Phase Counting Mode 3 (When MTUn.TCR2.PCB[1:0] is 01b (n = 1, 2))

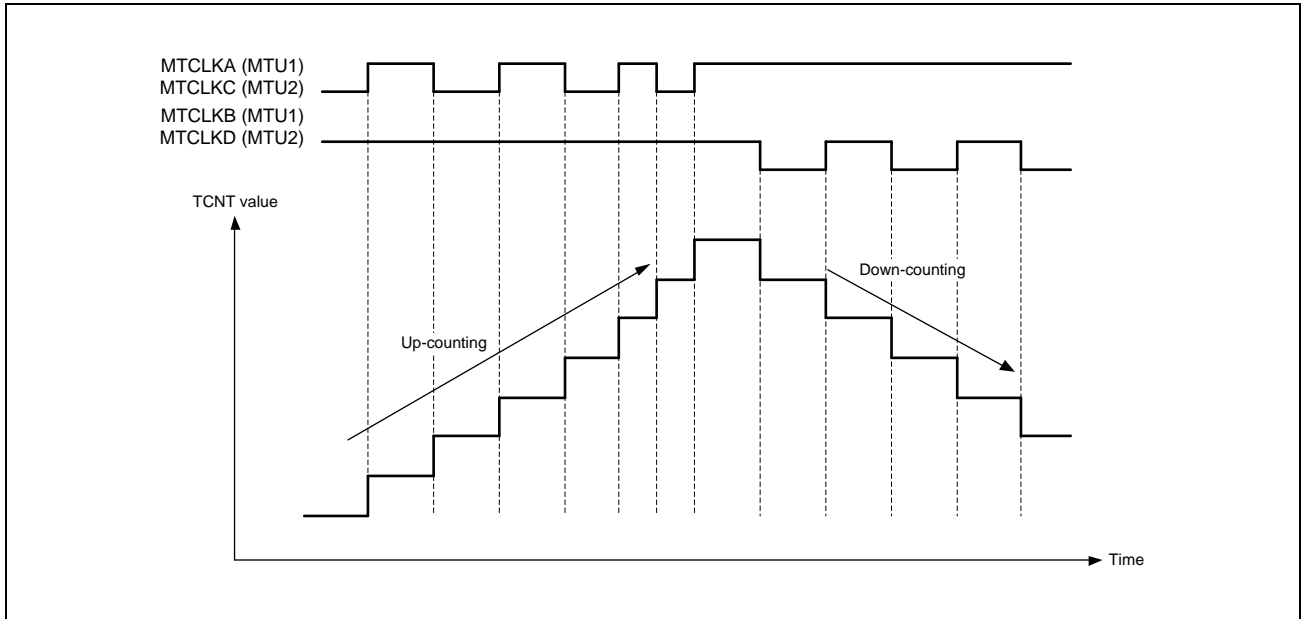



























Figure 16.37 Example of Operation in Phase Counting Mode 3 (When MTUn.TCR2.PCB[1:0] is 1xb (n = 1, 2))

Table 16.69 Up-Counting and Down-Counting Conditions in Phase Counting Mode 3

PCB[1:0]	MTCLKA (MTU1) MTCLKC (MTU2)	MTCLKB (MTU1) MTCLKD (MTU2)	Operation
00b	High		Not counted (Don't care)
	Low		
		Low	Up-counting
		High	
	High		Down-counting
	Low		Not counted (Don't care)
		High	
		Low	
01b	High		Down-counting
	Low		Not counted (Don't care)
		Low	
		High	
	High		Up-counting
	Low		
		High	
		Low	Not counted (Don't care)
1xb	High		Down-counting
	Low		Not counted (Don't care)
		Low	
		High	Up-counting
	High		Down-counting
	Low		Not counted (Don't care)
		High	
		Low	Not counted (Don't care)

Remarks:  : Rising edge
 : Falling edge

(d) Phase Counting Mode 4

Figure 16.38 shows an example of operation in phase counting mode 4, and **Table 16.70** summarizes the TCNT up- counting and down-counting conditions.

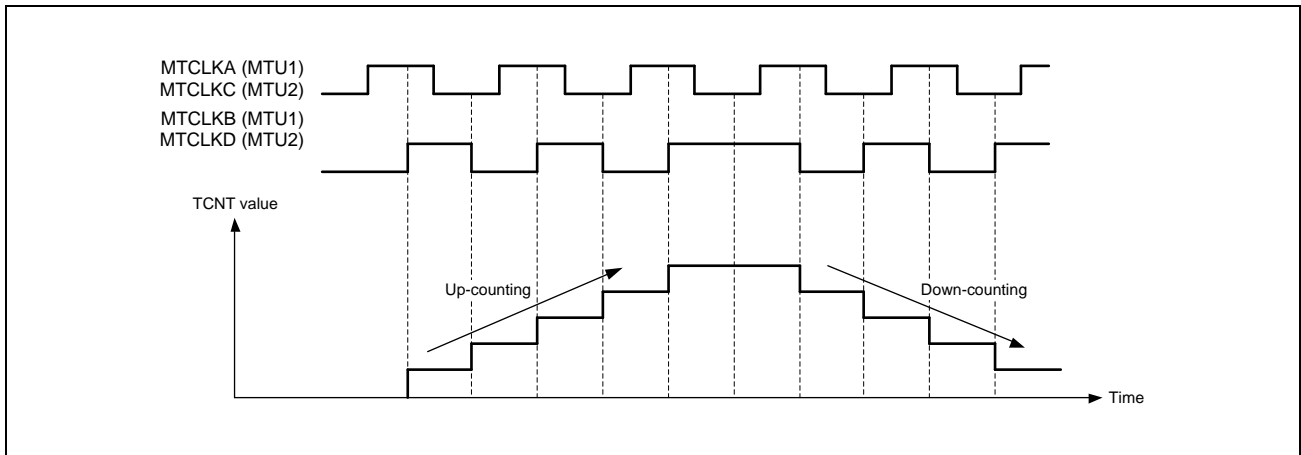

Figure 16.38 Example of Operation in Phase Counting Mode 4

Table 16.70 Up-Counting and Down-Counting Conditions in Phase Counting Mode 4

MTCLKA (MTU1) MTCLKC (MTU2)	MTCLKB (MTU1) MTCLKD (MTU2)	Operation
High		Up-counting
Low		Up-counting
	Low	Not counted (Don't care)
	High	Not counted (Don't care)
High		Down-counting
Low		Down-counting
	High	Not counted (Don't care)
	Low	Not counted (Don't care)

Remarks: : Rising edge
 : Falling edge

(e) Phase Counting Mode 5

Figure 16.39 and **Figure 16.40** show the examples of operation in phase counting mode 5 and **Table 16.71** summarizes the TCNT up-counting and down-counting conditions.

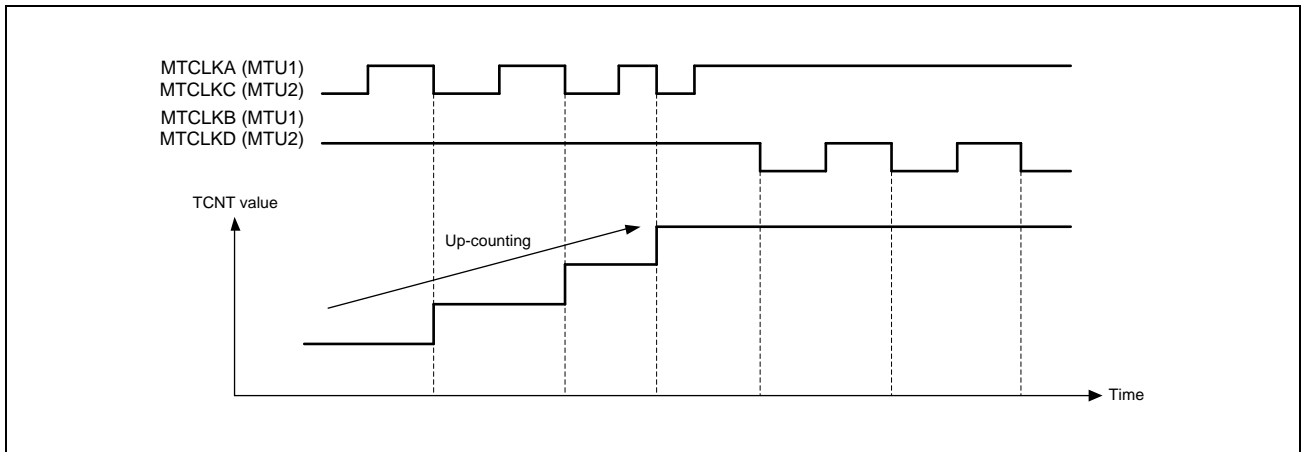

Figure 16.39 Example of Operation in Phase Counting Mode 5 (When MTUn.TCR2.PCB[1:0] = 0xb (n = 1, 2))

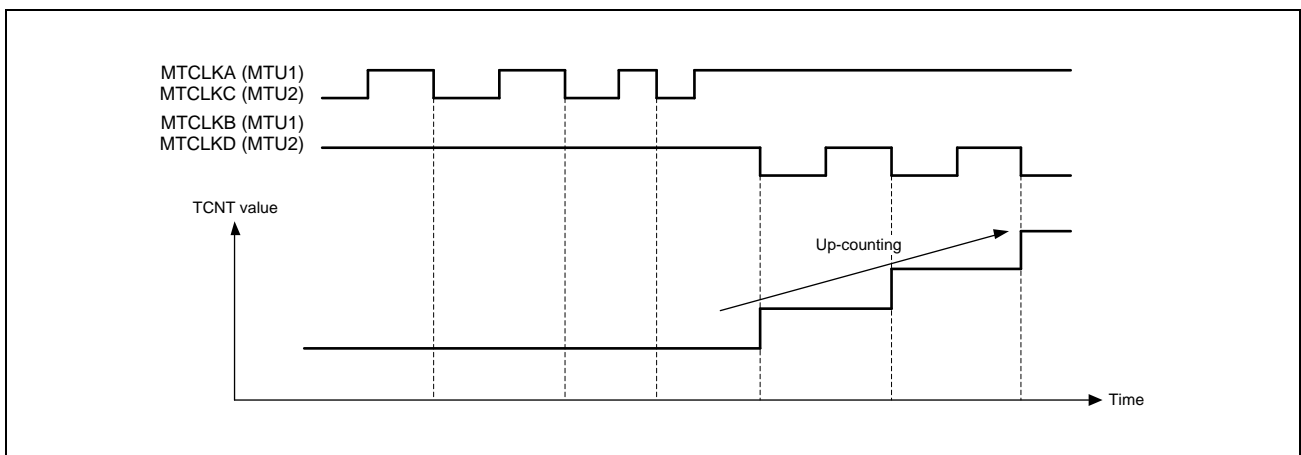



















Figure 16.40 Example of Operation in Phase Counting Mode 5 (When MTUn.TCR2.PCB[1:0] = 1xb (n = 1, 2))

Table 16.71 Up-Counting and Down-Counting Conditions in Phase Counting Mode 5

PCB[1:0]	MTCLKA (MTU1) MTCLKC (MTU2)	MTCLKB (MTU1) MTCLKD (MTU2)	Operation
0xb	High		Not counted (Don't care)
	Low		
		Low	Up-counting
		High	
	High		Not counted (Don't care)
	Low		
		High	Up-counting
		Low	
1xb	High		Not counted (Don't care)
	Low		Up-counting
		Low	Not counted (Don't care)
		High	Up-counting
	High		Up-counting
	Low		Not counted (Don't care)
		High	Up-counting
		Low	

Remarks:  : Rising edge
 : Falling edge

(3) 16-Bit Phase Counting Mode Application Example

Figure 16.41 shows an example in which MTU1 is in phase counting mode, and MTU1 is coupled with MTU0 to input 2-phase encoder pulses of a servo motor in order to detect position or speed.

MTU1 is set to phase counting mode 1, and the encoder pulse A-phase and B-phase are input to MTCLKA and MTCLKB.

In MTU0, MTU0.TGRC compare match is specified as the TCNT clearing source and MTU0.TGRA and MTU0.TGRC are used for the compare match function and are set with the speed control cycle and position control cycle.

MTU0.TGRB is used for input capture, with MTU0.TGRB and MTU0.TGRD operating in buffer mode. The MTU1 count clock is designated as the MTU0.TGRB input capture source, and the widths of 2-phase encoder 4-multiplication pulses are detected.

MTU1.TGRA and MTU1.TGRB for MTU1 are designated for the input capture function and MTU0.TGRA and MTU0.TGRC compare matches in MTU0 are selected as the input capture sources to store the up/down-counter values for the control cycles.

This procedure enables the accurate detection of position and speed.

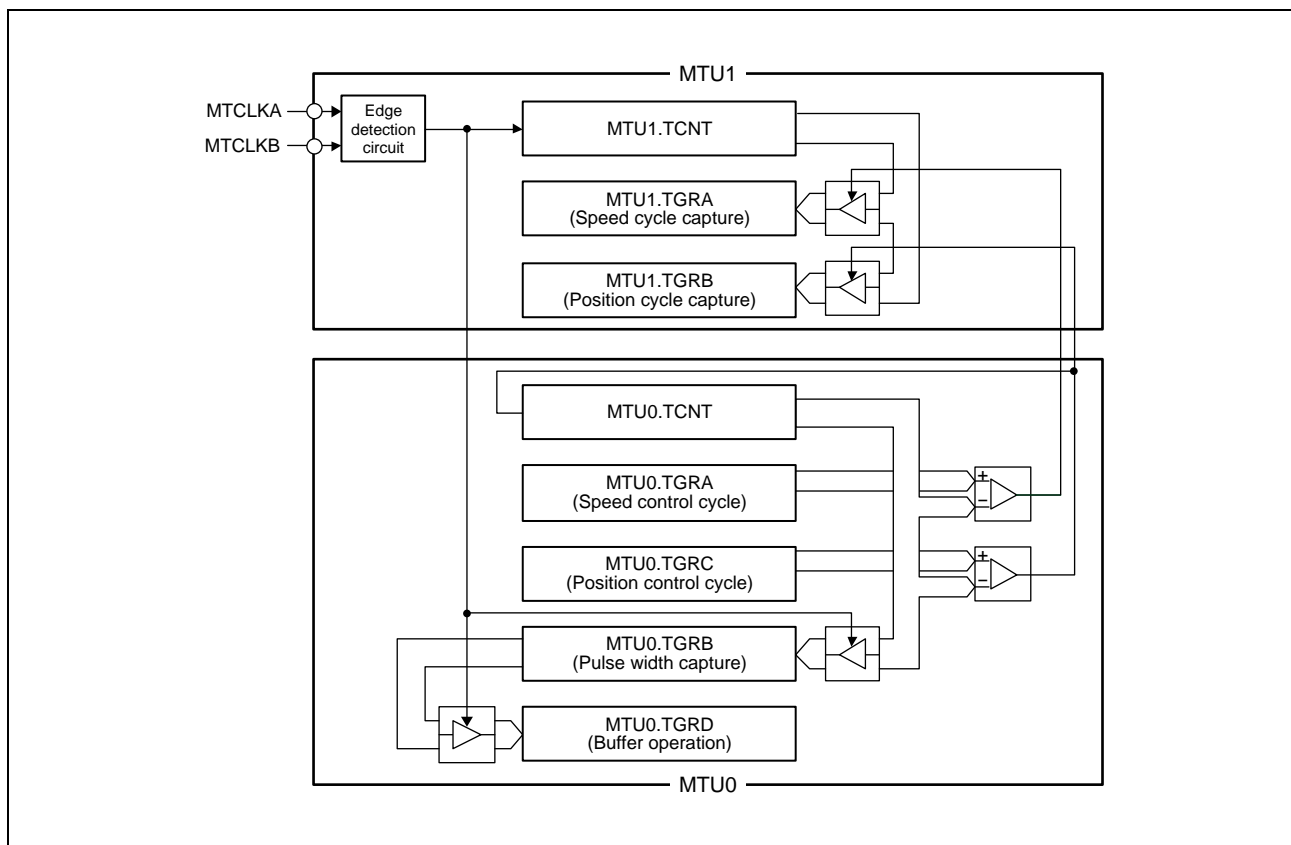

Figure 16.41 16-Bit Phase Counting Mode Application Example

16.3.6.2 Cascade Connection 32-Bit Phase Counting Mode

When MTU1 is set to phase counting mode by setting MTU1.TMDR3.LWA = 1, MTU1 and MTU2 are connected to operate in cascade connection 32-bit phase counting mode as shown in **Figure 16.42**. When this mode is used, the TCR, TCR2, TIOR, TIER, TGR, and TSR registers are controlled by MTU1 and the settings of MTU2 are disabled. See **Figure 16.43** for the procedure for setting cascade connection 32-bit phase counting mode.

In this mode, three-phase (A, B, and Z) signals can be input. As an encoder pulse signal, the external input phase clocks MTCLKA and MTCLKB or MTCLKC and MTCLKD can be selected for A-phase and B-phase, and MTIOC1A can be selected for Z-phase, respectively. See **Table 16.70** for selecting external clock input of A-phase and B-phase. A counter event is generated using an A-phase or B-phase pulse and counted by the 32-bit counter MTU1.TCNTLW.

An input capture can also be generated using a Z-phase signal; thus, an angular velocity can be measured using the value captured in the general register.

Furthermore, MTU8 can be used as a channel for measuring a 1-ms interval, and a compare match signal can be output at a 1-ms interval to the MTU1 and MTU2, which operate in cascade connection 32-bit phase counting mode. That is, a compare match signal of MTU8 is used as a capture signal of MTU1 and MTU2, and the number of A-phase and B-phase pulses for a 1-ms period can be measured.

When MTU0 or MTU5 is specified as the channel for measuring Z-phase signal pulses, this compare match signal of TGRC in MTU8 can be output as a capture signal or a clear signal to MTU0 or MTU5; thus, the Z-phase count can be measured at 1-ms intervals.

In addition, a counter event signal of combined MTU1 and MTU2 can be used as a capture signal of TGRD in MTU8, and measurement can be performed including the intervals of A, B, or both phase pulses. In this case, the TGRD register in MTU8 should be set to buffer operation.

Refer to **Section 16.3.4, Cascaded Operation**, for details on the cascade connection function for connecting MTU1 and MTU2 in a mode other than cascade connection 32-bit phase counting mode.

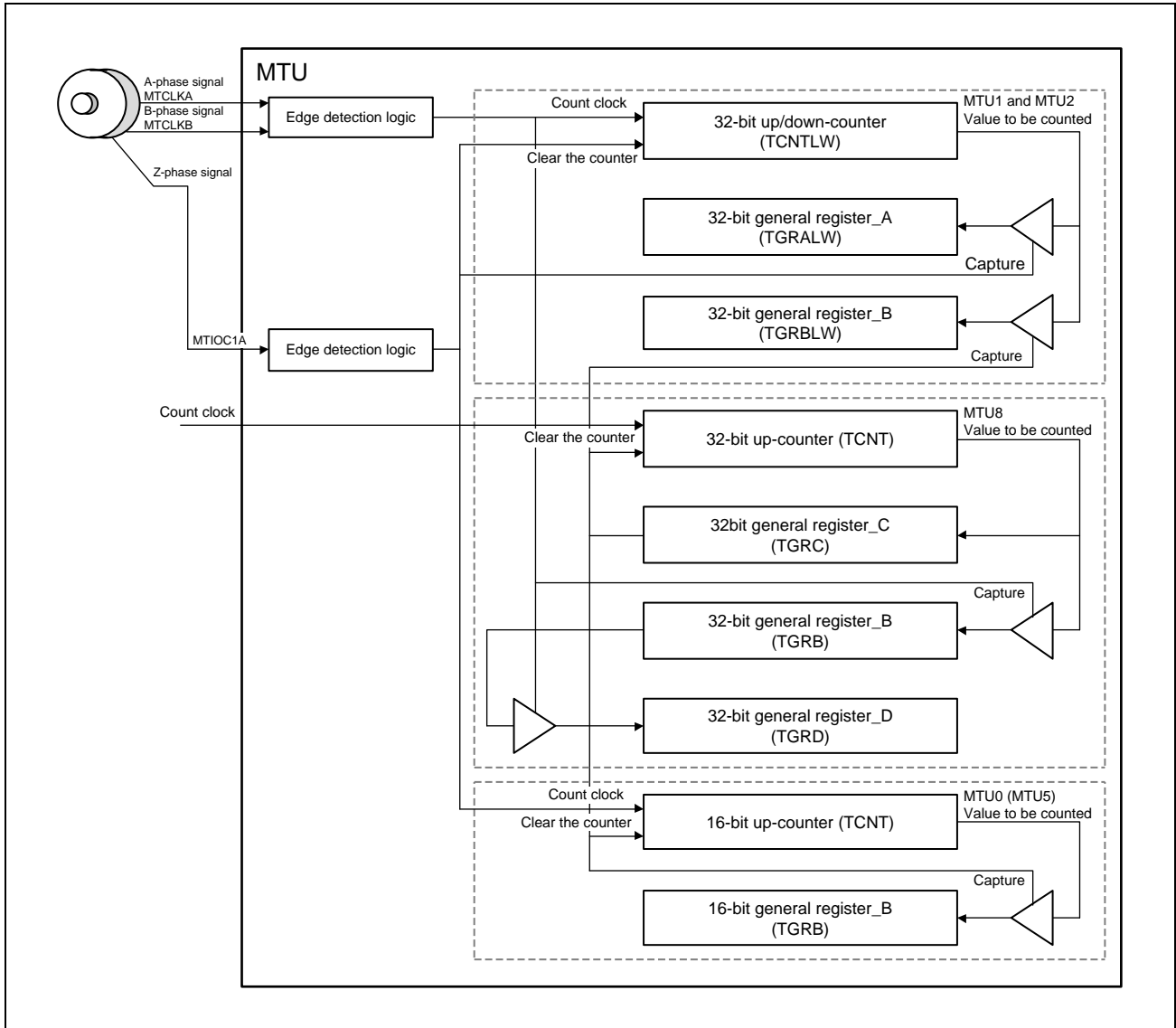

Figure 16.42 Block Diagram for Operation in Cascade Connection 32-Bit Phase Counting Mode

(1) Example of Setting Cascade Connection 32-Bit Phase Counting Mode

Figure 16.43 shows an example of the procedure for setting cascade connection 32-bit phase counting mode.

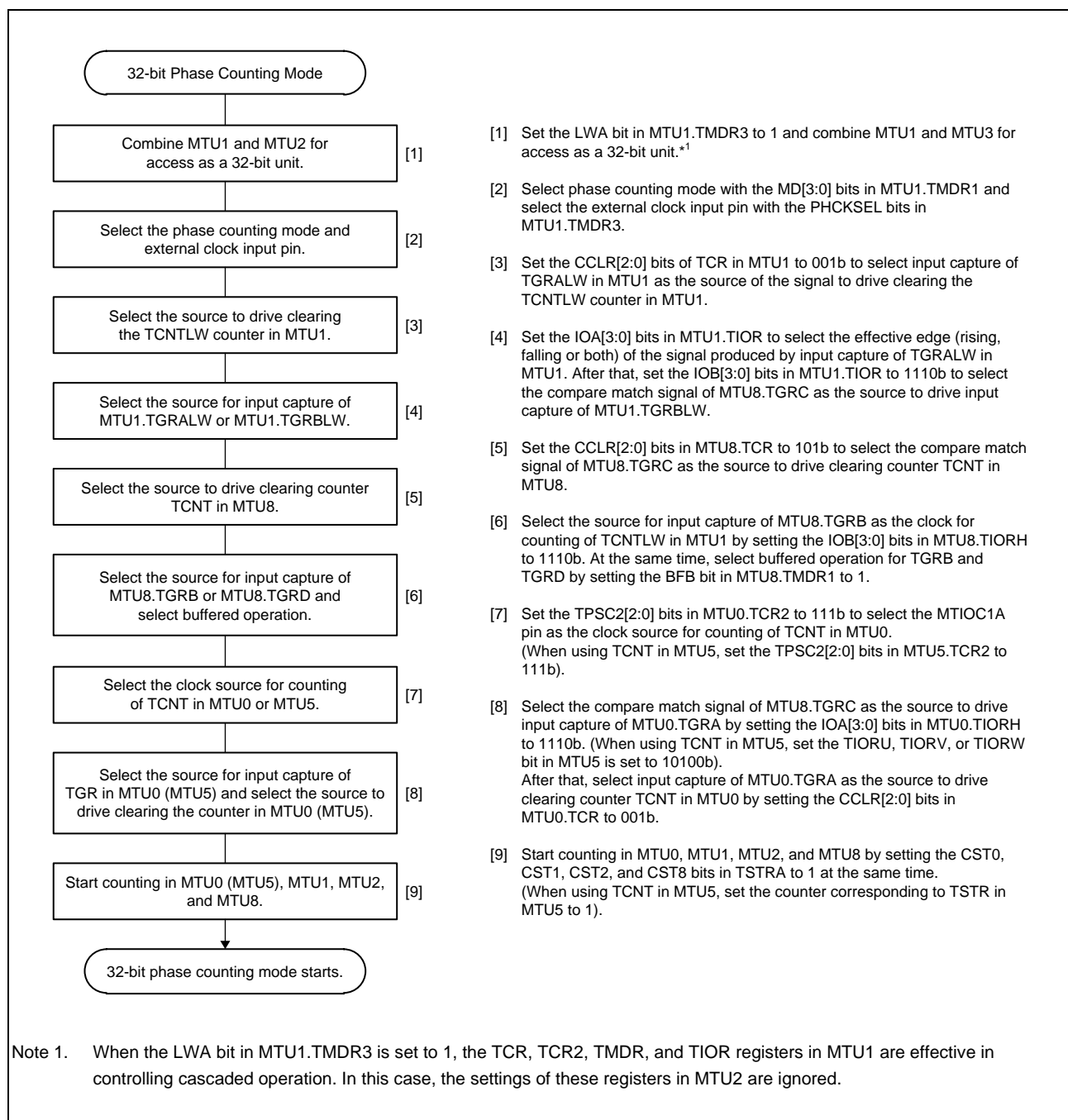

Figure 16.43 Procedure for Setting Cascade Connection 32-Bit Phase Counting Mode

16.3.7 Reset-Synchronized PWM Mode

In the reset-synchronized PWM mode, three phases of positive and negative PWM waveforms (six phases in total) that share a common wave transition point can be output by combining MTU3 and MTU4 and MTU6 and MTU7.

When set for reset-synchronized PWM mode, the MTIOC3B, MTIOC3D, MTIOC4A, MTIOC4C, MTIOC4B, MTIOC4D, MTIOC6B, MTIOC6D, MTIOC7A, MTIOC7C, MTIOC7B, and MTIOC7D pins function as PWM output pins and timer counters 6 and 12 (MTU3.TCNT and MTU6.TCNT) functions as an up-counter.

Table 16.72 shows the PWM output pins used. **Table 16.73** shows the settings of the registers.

Table 16.72 Output Pins for Reset-Synchronized PWM Mode

Channel	Output Pin	Description
MTU3	MTIOC3B	PWM output pin 1
	MTIOC3D	PWM output pin 1' (negative-phase waveform of PWM output 1)
MTU4	MTIOC4A	PWM output pin 2
	MTIOC4C	PWM output pin 2' (negative-phase waveform of PWM output 2)
	MTIOC4B	PWM output pin 3
	MTIOC4D	PWM output pin 3' (negative-phase waveform of PWM output 3)
MTU6	MTIOC6B	PWM output pin 4
	MTIOC6D	PWM output pin 4' (negative-phase waveform of PWM output 4)
MTU7	MTIOC7A	PWM output pin 5
	MTIOC7C	PWM output pin 5' (negative-phase waveform of PWM output 5)
	MTIOC7B	PWM output pin 6
	MTIOC7D	PWM output pin 6' (negative-phase waveform of PWM output 6)

Table 16.73 Register Settings for Reset-Synchronized PWM Mode

Register	Setting
MTU3.TCNT	Initial setting (H'0000)
MTU4.TCNT	Initial setting (H'0000)
MTU3.TGRA	Set the count cycle for MTU3.TCNT
MTU3.TGRB	Set the transition point of the PWM waveform to be output from the MTIOC3B and MTIOC3D pins
MTU4.TGRA	Set the transition point of the PWM waveform to be output from the MTIOC4A and MTIOC4C pins
MTU4.TGRB	Set the transition point of the PWM waveform to be output from the MTIOC4B and MTIOC4D pins
MTU6.TCNT	Initial setting (H'0000)
MTU7.TCNT	Initial setting (H'0000)
MTU6.TGRA	Set the count cycle for MTU6.TCNT
MTU6.TGRB	Set the transition point of the PWM waveform to be output from the MTIOC6B and MTIOC6D pins
MTU7.TGRA	Set the transition point of the PWM waveform to be output from the MTIOC7A and MTIOC7C pins
MTU7.TGRB	Set the transition point of the PWM waveform to be output from the MTIOC7B and MTIOC7D pins

(1) Example of Procedure for Setting Reset-Synchronized PWM Mode

Figure 16.44 shows an example of the procedure for specifying the reset-synchronized PWM mode.

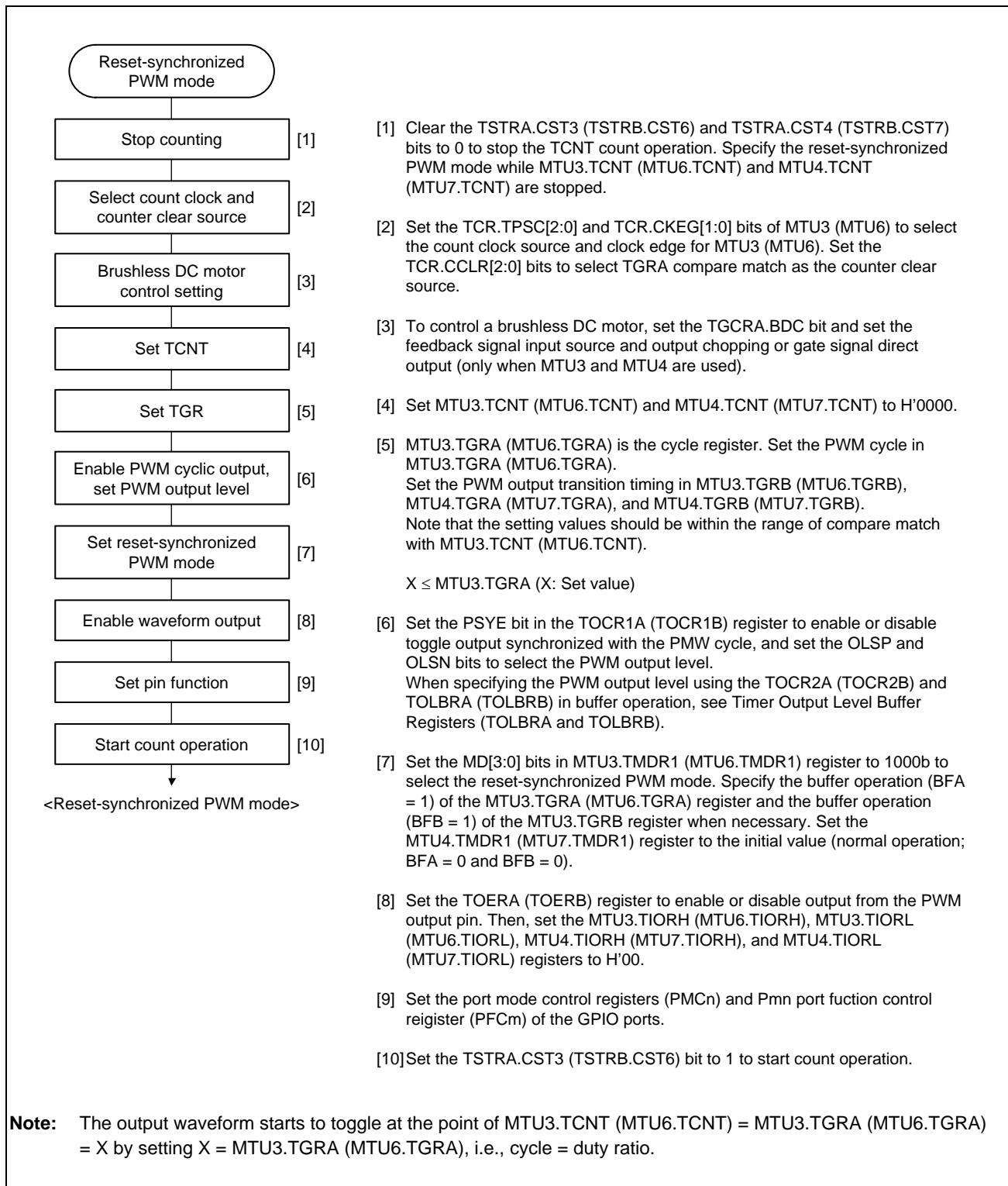

Figure 16.44 Procedure for Selecting Reset-Synchronized PWM Mode

(2) Example of Reset-Synchronized PWM Mode Operation

Figure 16.45 shows an example of operation in the reset-synchronized PWM mode.

MTU3.TCNT and MTU4.TCNT (MTU6.TCNT and MTU7.TCNT) operate as up-counters. The counters are cleared when a compare match occurs between MTU3.TCNT (MTU6.TCNT) and MTU3.TGRA (MTU6.TGRA), and then begin incrementing from H'0000. The output from the PWM pins toggles every time a compare match occurs in MTU3.TGRB (MTU6.TGRB), MTU4.TGRA (MTU7.TGRA), and MTU4.TGRB (MTU7.TGRB) and the counters are cleared.

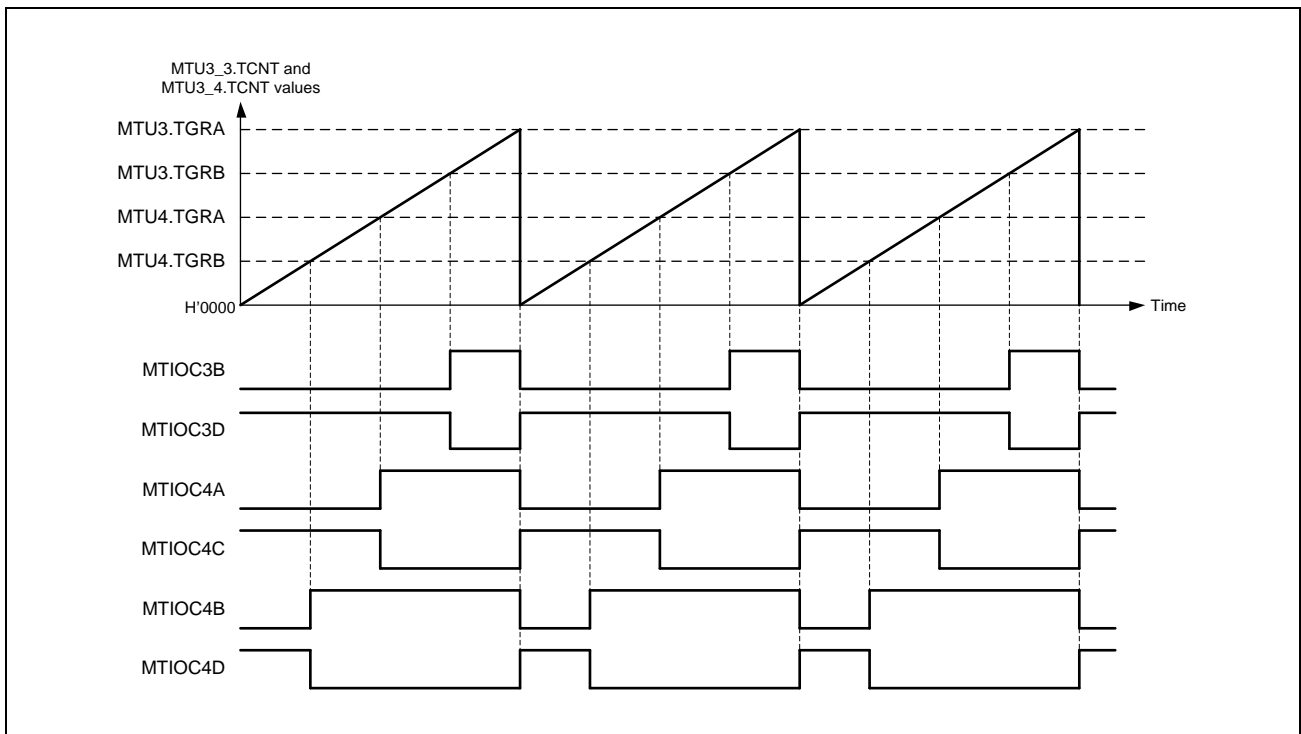

Figure 16.45 Example of Reset-Synchronized PWM Mode Operation
(When OLSN = 1 and OLSP = 1 in MTU3.TOCR1 and MTU4.TOCR1)

16.3.8 Complementary PWM Mode

In complementary PWM mode, dead time can be set for PWM waveforms to be output. The dead time is the period during which the upper and lower arm transistors are set to the inactive level in order to prevent short-circuiting of the arms.

Six positive-phase and six negative-phase PWM waveforms (12 phases in total) with dead time can be output by combining MTU3/ MTU4 and MTU6/MTU7. PWM waveforms without dead time can also be output.

In complementary PWM mode, MTIOC3B, MTIOC3D, MTIOC4A, MTIOC4B, MTIOC4C, MTIOC4D, MTIOC6B, MTIOC6D, MTIOC7A, MTIOC7B, MTIOC7C, and MTIOC7D pins function as PWM output pins, and the MTIOC3A and MTIOC6A pins can be set for toggle output synchronized with the PWM cycle.

MTU3.TCNT, MTU4.TCNT, MTU6.TCNT, and MTU7.TCNT function as up/down-counters.

Table 16.74 shows the PWM output pins used. **Table 16.75** shows the settings of the registers used.

A function to directly cut off the PWM output by using an external signal is supported as a port function.

Table 16.74 Output Pins for Complementary PWM Mode

Channel	Output Pin	Description
MTU3	MTIOC3A	Toggle output synchronized with PWM cycle (or I/O port)
	MTIOC3B	PWM output pin 1
	MTIOC3C	I/O port* ¹
	MTIOC3D	PWM output pin 1' (negative-phase waveform output of PWM output 1)
MTU4	MTIOC4A	PWM output pin 2
	MTIOC4C	PWM output pin 2' (negative-phase waveform output of PWM output 1)
	MTIOC4B	PWM output pin 3
	MTIOC4D	PWM output pin 3' (negative-phase waveform output of PWM output 1)
MTU6	MTIOC6A	Toggle output synchronized with PWM cycle (or I/O port)
	MTIOC6B	PWM output pin 4
	MTIOC6C	I/O port* ¹
	MTIOC6D	PWM output pin 4' (negative-phase waveform output of PWM output 4)
MTU7	MTIOC7A	PWM output pin 5
	MTIOC7C	PWM output pin 5' (negative-phase waveform output of PWM output 5)
	MTIOC7B	PWM output pin 6
	MTIOC7D	PWM output pin 6' (negative-phase waveform output of PWM output 6)

Note 1. Avoid setting the MTIOC3C and MTIOC6C pins as timer I/O pins in complementary PWM mode.

Table 16.75 Register Settings for Complementary PWM Mode (1/2)

Channel	Counter / Register	Description	Read/Write from CPU
MTU3	TCNT	Starts up-counting from the value set in the dead time register	Maskable by TRWERA setting* ¹
	TGRA	Set MTU3.TCNT upper limit value (1/2 carrier cycle + dead time)	Maskable by TRWERA setting* ¹
	TGRB	PWM output 1 compare register	Maskable by TRWERA setting* ¹
	TGRC	MTU3.TGRA buffer register	Readable/writable
	TGRD	PWM output 1/MTU3.TGRB buffer register	Readable/writable
	TGRE	MTU3.TGRB buffer register B (when double buffer function is used)	Readable/writable
MTU4	TCNT	Starts up-counting after being initialized to H'0000	Maskable by TRWERA setting* ¹
	TGRA	PWM output 2 compare register	Maskable by TRWERA setting* ¹
	TGRB	PWM output 3 compare register	Maskable by TRWERA setting* ¹
	TGRC	PWM output 2/MTU4.TGRA buffer register	Readable/writable
	TGRD	PWM output 3/MTU4.TGRB buffer register	Readable/writable
	TGRE	MTU4.TGRA buffer register B (when double buffer function is used)	Readable/writable
MTU6	TCNT	Starts up-counting from the value set in the dead time register	Maskable by TRWERB setting* ²
	TGRA	Set MTU6.TCNT upper limit value (1/2 carrier cycle + dead time)	Maskable by TRWERB setting* ²
	TGRB	PWM output 4 compare register	Maskable by TRWERB setting* ²
	TGRC	MTU6.TGRA buffer register	Readable/writable
	TGRD	PWM output 4/MTU6.TGRB buffer register	Readable/writable
	TGRE	MTU6.TGRB buffer register B (when double buffer function is used)	Readable/writable
MTU7	TCNT	Starts up-counting after being initialized to H'0000	Maskable by TRWERB setting* ²
	TGRA	PWM output 5 compare register	Maskable by TRWERB setting* ²
	TGRB	PWM output 6 compare register	Maskable by TRWERB setting* ²
	TGRC	PWM output 5/MTU7.TGRA buffer register	Readable/writable
	TGRD	PWM output 6/MTU7.TGRB buffer register	Readable/writable
	TGRE	MTU7.TGRA buffer register B (when double buffer function is used)	Readable/writable
	TGRF	MTU7.TGRB buffer register B (when double buffer function is used)	Readable/writable

Note 1. Access can be enabled or disabled according to the setting in TRWERA (timer read/write enable register A).

Note 2. Access can be enabled or disabled according to the setting in TRWERB (timer read/write enable register B).

Table 16.76 Register Settings for Complementary PWM Mode (2/2)

Counter / Register	Description	Read/Write from CPU
Timer dead time data register A (TDDRA)	Set MTU4.TCNT and MTU3.TCNT offset value (dead time value)	Maskable by TRWERA setting* ¹
Timer dead time data register B (TDDR B)	Set MTU7.TCNT and MTU6.TCNT offset value (dead time value)	Maskable by TRWERB setting* ²
Timer cycle data register A (TC DRA)	Set MTU4.TCNT upper limit value (1/2 carrier cycle)	Maskable by TRWERA setting* ¹
Timer cycle data register B (TC DRB)	Set MTU7.TCNT upper limit value (1/2 carrier cycle)	Maskable by TRWERB setting* ²
Timer cycle buffer register A (TCBRA)	TC DRA buffer register	Readable/writable
Timer cycle buffer register B (TCBRB)	TC DRB buffer register	Readable/writable
Subcounter A (TCNTSA)	Subcounter A for dead time generation	Read-only
Subcounter B (TCNTSB)	Subcounter B for dead time generation	Read-only
Temporary register 1A (TEMP1A)	PWM output 1/MTU3.TGRB temporary register A	Not readable or writable
Temporary register 1B (TEMP1B)	PWM output 1/MTU3.TGRB temporary register B (when double buffer function is used)	Not readable or writable
Temporary register 2A (TEMP2A)	PWM output 2/MTU4.TGRA temporary register A	Not readable or writable
Temporary register 2B (TEMP2B)	PWM output 2/MTU4.TGRA temporary register B (when double buffer function is used)	Not readable or writable
Temporary register 3A (TEMP3A)	PWM output 3/MTU4.TGRB temporary register A	Not readable or writable
Temporary register 3B (TEMP3B)	PWM output 3/MTU4.TGRB temporary register B (when double buffer function is used)	Not readable or writable
Temporary register 4A (TEMP4A)	PWM output 4/MTU6.TGRB temporary register A	Not readable or writable
Temporary register 4B (TEMP4B)	PWM output 4/MTU6.TGRB temporary register B (when double buffer function is used)	Not readable or writable
Temporary register 5A (TEMP5A)	PWM output 5/MTU7.TGRA temporary register A	Not readable or writable
Temporary register 5B (TEMP5B)	PWM output 5/MTU7.TGRA temporary register B (when double buffer function is used)	Not readable or writable
Temporary register 6A (TEMP6A)	PWM output 6/MTU7.TGRB temporary register A	Not readable or writable
Temporary register 6B (TEMP6B)	PWM output 6/MTU7.TGRB temporary register B (when double buffer function is used)	Not readable or writable

Note 1. Access can be enabled or disabled according to the setting in TRWERA (timer read/write enable register A).

Note 2. Access can be enabled or disabled according to the setting in TRWERB (timer read/write enable register B).

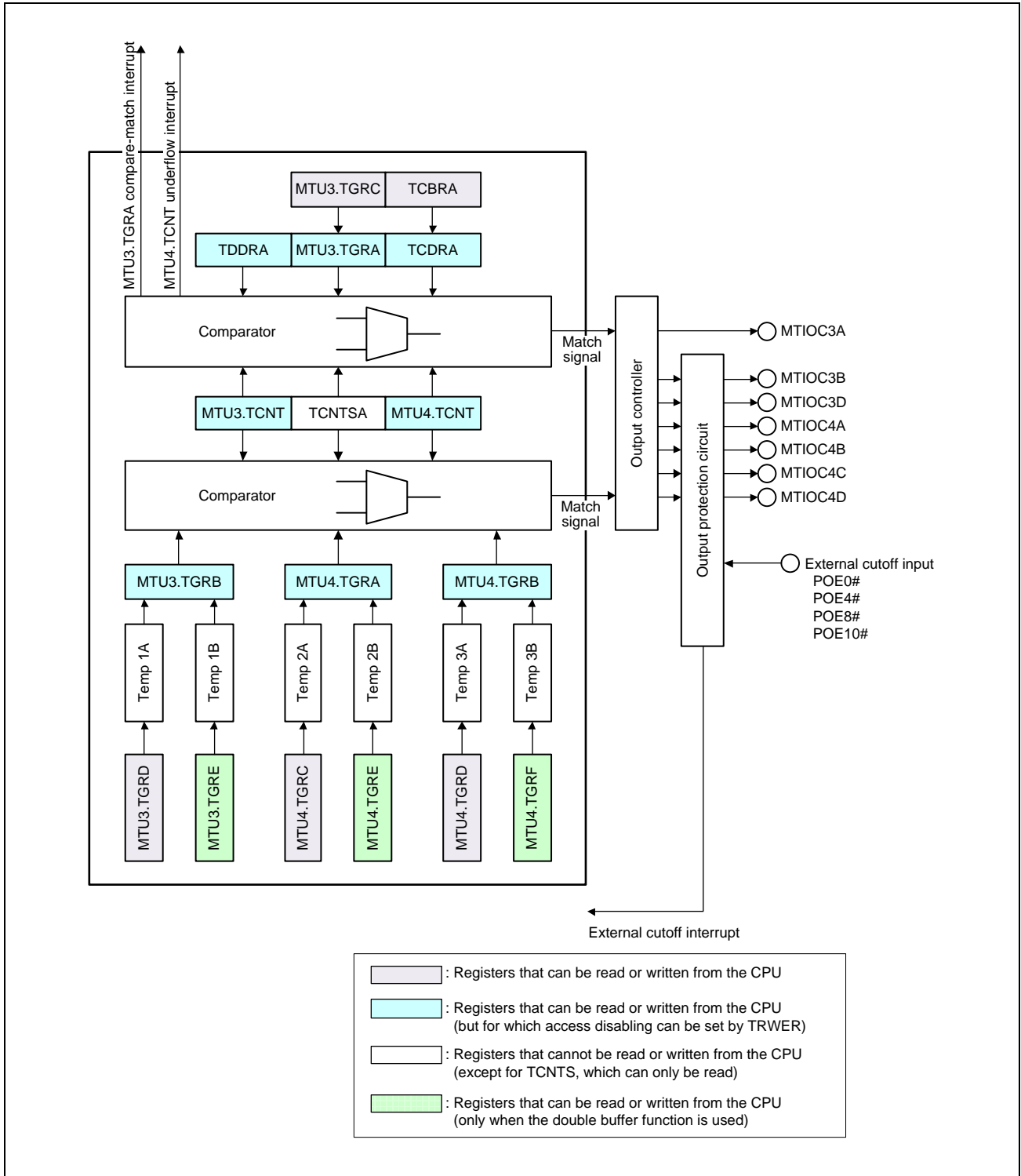

Figure 16.46 Block Diagram of MTU3 and MTU4 in Complementary PWM Mode

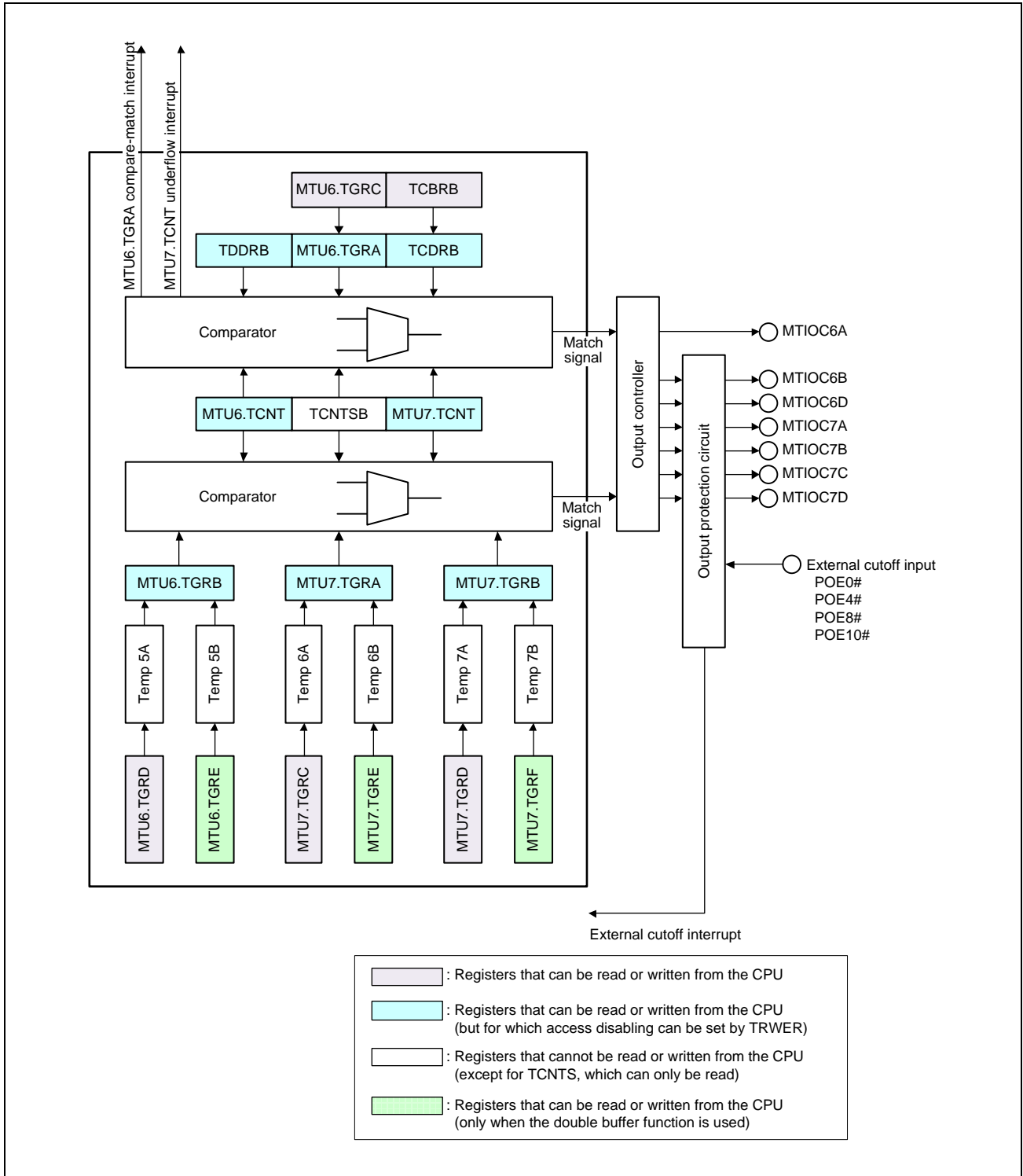

Figure 16.47 Block Diagram of MTU6 and MTU7 in Complementary PWM Mode

(1) Example of Complementary PWM Mode Setting Procedure

Figure 16.48 shows an example of the complementary PWM mode setting procedure.

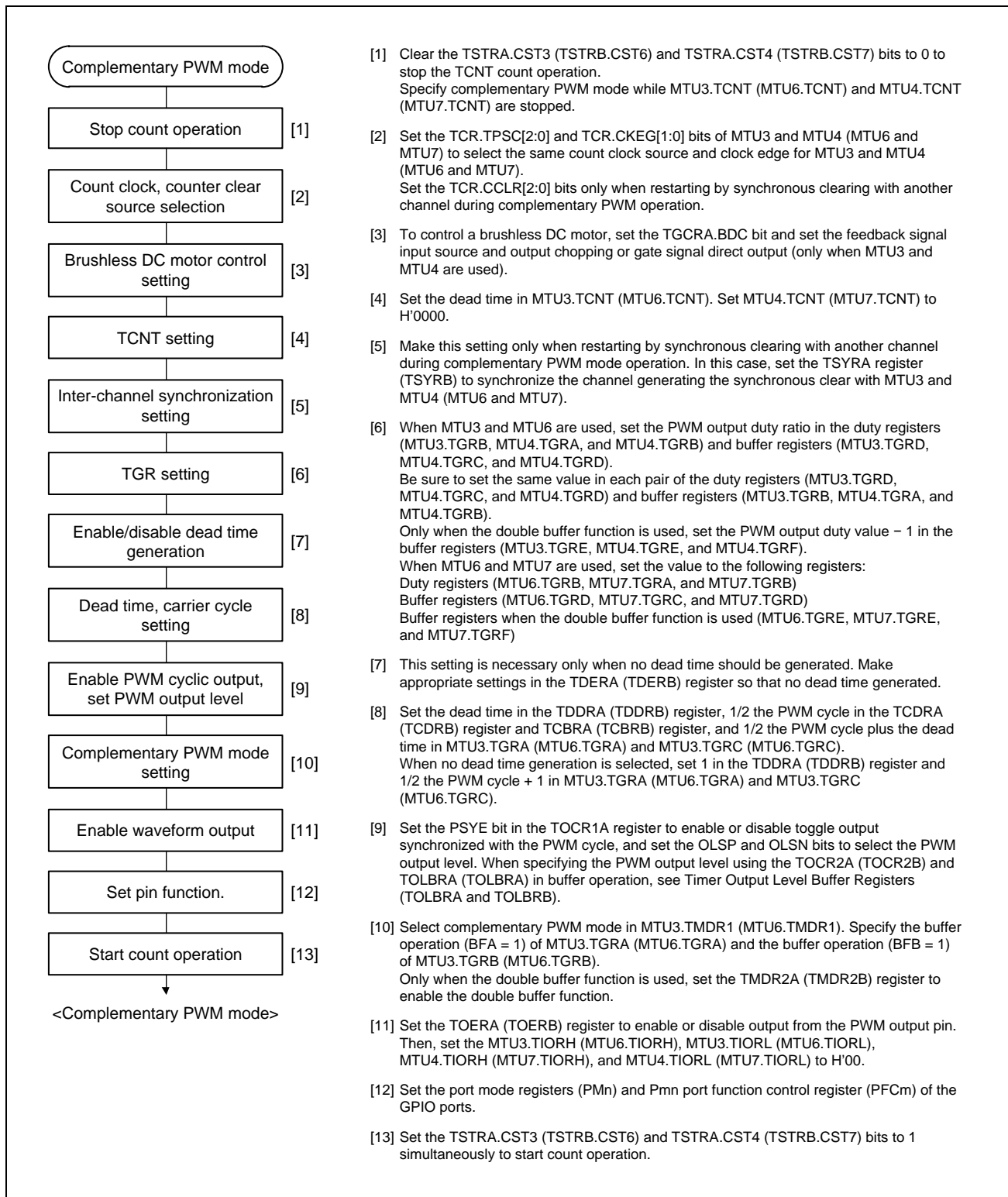

Figure 16.48 Example of Complementary PWM Mode Setting Procedure

(2) Outline of Complementary PWM Mode Operation

In complementary PWM mode, six phases (three positive and three negative) PWM waveforms can be output. **Figure 16.49** illustrates counter operation in complementary PWM mode (MTU3 and MTU4), and **Figure 16.50** shows an example of operation in complementary PWM mode.

(a) Counter Operation

In complementary PWM mode, three counters — MTU3.TCNT, MTU4.TCNT, and TCNTSA (MTU6.TCNT, MTU7.TCNT, and TCNTSB) — in each unit perform up-/down-count operations.

MTU3.TCNT (MTU6.TCNT) is automatically initialized to the value set in TDDRA (TDDRB) when complementary PWM mode is selected and the CST3 bit in TSTRA (TSTRB) is 0. When the CST3 bit is set to 1, MTU3.TCNT (MTU6.TCNT) counts up to the value set in MTU3.TGRA (MTU6.TGRA), then switches to down-counting when it matches MTU3.TGRA (MTU6.TGRA). When the MTU4.TCNT (MTU7.TCNT) value matches H'0000, MTU3.TCNT (MTU6.TCNT) switches to up-counting, and the operation is repeated in this way.

TCNT in MTU4 (MTU7) should be initialized to H'0000 after a reset. When the CST4 bit is set to 1, MTU4.TCNT (MTU7.TCNT) counts up in synchronization with MTU3.TCNT (MTU6.TCNT), and switches to down-counting when MTU3.TCNT (MTU6.TCNT) matches MTU3.TGRA (MTU6.TGRA). On reaching H'0000, MTU4.TCNT (MTU7.TCNT) switches to up-counting, and the operation is repeated in this way. TCNTSA (TCNTSB) is a read-only counter. It does not need to be initialized after a reset.

In counting up by MTU3.TCNT and MTU4.TCNT (or MTU6.TCNT and MTU7.TCNT), MTU3.TCNT (or MTU6.TCNT) starts counting up when it matches TCDRA (or TCDRB) and switches to counting down when it matches MTU3.TGRA (or MTU6.TGRA). Furthermore, when MTU4.TCNT (or MTU7.TCNT) matches TDDRA (or TDDRB), TCNTSA (or TCNTSB) is set to the value in MTU3.TGRA (or MTU6.TGRA) and counting is stopped.

When MTU4.TCNT (MTU7.TCNT) matches TDDRA (TDDRB) during down-counting of MTU3.TCNT and MTU4.TCNT (MTU6.TCNT and MTU7.TCNT), TCNTSA (TCNTSB) starts up-counting, and when MTU4.TCNT (MTU7.TCNT) matches H'0000, the operation switches to down-counting. When MTU3.TCNT (MTU6.TCNT) matches TCDRA (TCDRB), TCNTSA (TCNTSB) is cleared to H'0000 and stops counting.

TCNTSA (TCNTSB) is compared with the compare register and temporary register, in which the PWM duty is specified, only during the count operation.

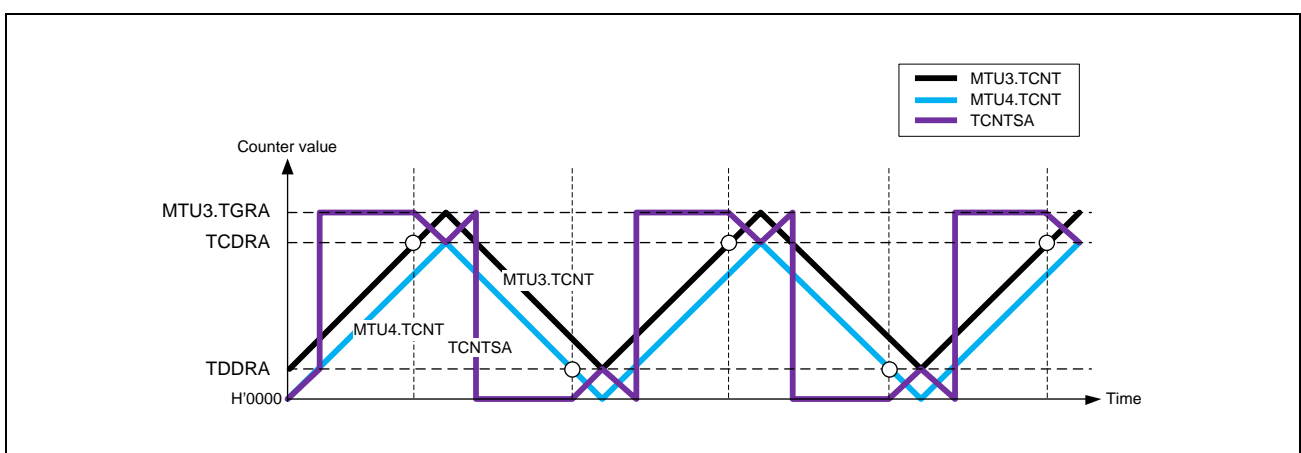

Figure 16.49 Count Operation in Complementary PWM Mode (MTU3 and MTU4)

(b) Register Operation

In complementary PWM mode, nine registers (compare registers, buffer registers, and temporary registers) are used to control the duty ratio for the PWM output. **Figure 16.50** shows an example of operation in complementary PWM mode (MTU3 and MTU4).

MTU3.TGRB, MTU4.TGRA, and MTU4.TGRB (MTU6.TGRB, MTU7.TGRA, and MTU7.TGRB) are constantly compared with the counters to generate PWM waveforms. When these registers match the counter, the value set in the OLSN and OLSP bits in the timer output control registers (TOCR1A and TOCR1B) is output from the PWM output pin. MTU3.TGRD, MTU4.TGRC, and MTU4.TGRD (MTU6.TGRD, MTU7.TGRC, and MTU7.TGRD) are buffer registers for these compare registers.

When the double buffer function is used, MTU3.TGRE, MTU4.TGRE, and MTU4.TGRF (MTU6.TGRE, MTU7.TGRE, and MTU7.TGRF) are also used as buffer registers B. For details of double buffer operation, refer to **Section 16.3.8(2)(s), Double Buffer Function in Complementary PWM Mode**.

Data in a compare register can be changed by writing new data to the corresponding buffer register. The buffer registers can be read or written at any time.

When modifying data in a buffer register, write to MTU4.TGRD (MTU7.TGRD) last and enable data transfer from the buffer register to a temporary register. At this time, transfer from the TCBRA (TCBRB) register and MTU3.TGRC (MTU6.TGRC) register, which operate as buffer registers for the timer cycle registers, to temporary registers is also enabled. Data is transferred to all five temporary registers at the same time.

When transfer is enabled in the Ta interval, data written to a buffer register is transferred to the temporary register. The data is not transferred to the temporary register in the Tb1 and Tb2 intervals. Data enabled for transfer in this interval is transferred to the temporary register at the end of this interval.

The value transferred to a temporary register is transferred to the compare register at the end of the Tb1 interval (when matches MTU3.TGRA (MTU6.TGRA) while TCNTSA (TCNTSB) is counting up), or at the end of the Tb2 interval (when matches H'0000 while TCNTSA (TCNTSB) is counting down). The timing for transfer from the temporary register to the compare register can be selected with bits MD[3:0] in the timer mode register 1 (TMDR1). **Figure 16.50** shows an example in which the trough is selected for the transfer timing.

In the Tb interval in which data is not transferred to the temporary register (Tb1 in **Figure 16.50**), the temporary register has the same function as the compare register and is compared with the counter. In this interval, therefore, there are two compare match registers for one output phase; the compare register contains the pre-change data and the temporary register contains new data. In this interval, three counters MTU3.TCNT, MTU4.TCNT, and TCNTSA (MTU6.TCNT, MTU7.TCNT, and TCNTSB) and two registers (compare register and temporary register) are compared, and PWM output is controlled accordingly.

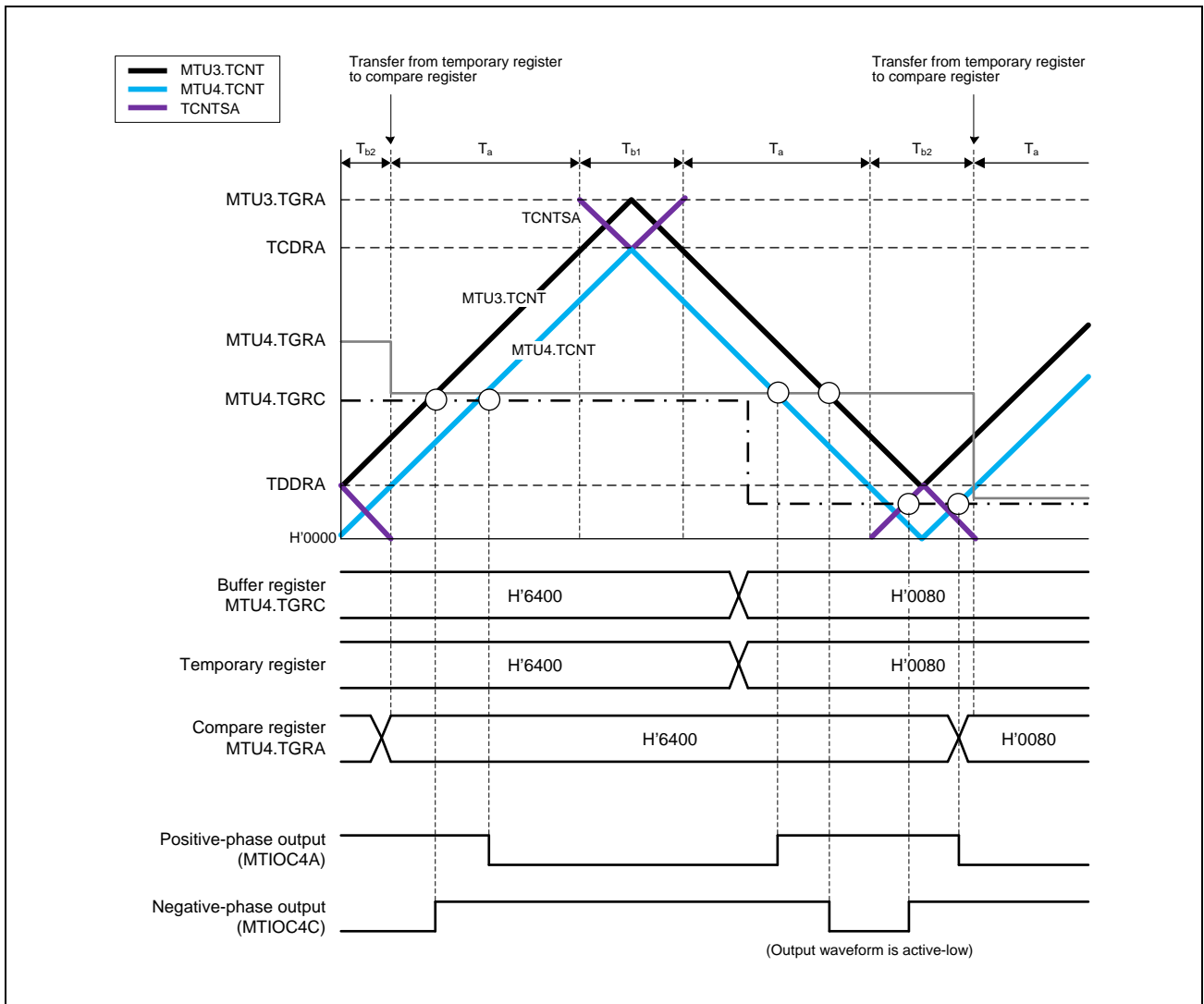

Figure 16.50 Example of Operation in Complementary PWM Mode (MTU3 and MTU4)

(c) Initial Setting

In complementary PWM mode, there are nine registers that require initial setting. In addition, there is a register that specifies whether to generate dead time (it should be used only when dead time generation should be disabled).

Before setting complementary PWM mode with MTU3.TMDR1.MD[3:0] (MTU6.TMDR1.MD[3:0]) bits, initial values should be set in the following registers.

The TOCR1A, TOCR2A, TOCR1B, and TOCR2B registers are used to set the PWM output level. MTU3.TGRC (MTU6.TGRC) operates as the buffer register for MTU3.TGRA (MTU6.TGRA), and should be set with 1/2 the PWM cycle + dead time Td. The timer cycle buffer register (TCBRA or TCBRB) operates as the buffer register for the timer cycle data register (TCDRA or TCDRB), and should be set with 1/2 the PWM cycle. Set dead time Td in the timer dead time data register (TDDRA or TDDRB).

When dead time is not needed, the TDER bit in the timer dead time enable register (TDERA or TDERB) should be cleared to 0, MTU3.TGRC and MTU3.TGRA (MTU6.TGRC and MTU6.TGRA) should be set to 1/2 the PWM carrier cycle + 1, and TDDRA (TDDRB) should be set to 1.

Set the respective initial PWM duty values in three buffer registers A (MTU3.TGRD, MTU4.TGRC, and MTU4.TGRD (MTU6.TGRD, MTU7.TGRC, and MTU7.TGRD)).

Set the respective (initial PWM duty – 1) values in three buffer registers B (MTU3.TGRE, MTU4.TGRE, and MTU4.TGRF (MTU6.TGRE, MTU7.TGRE, and MTU7.TGRF)) only when the double buffer function is used.

The values set in the five buffer registers excluding TDDRA (TDDRB) are transferred to the corresponding compare registers as soon as complementary PWM mode is set.

Set MTU4.TCNT (MTU7.TCNT) to H'0000 before setting complementary PWM mode.

Table 16.77 Registers and Counters Requiring Initial Setting

Register and Counter	Setting
TOCR1A, TOCR2A, TOCR1B, TOCR2B	PWM output level
MTU3.TGRC MTU6.TGRC	1/2 PWM cycle + dead time Td (1/2 PWM cycle + 1 when dead time generation is disabled by the TDERA or TDERB setting)
TDDRA, TDDRB	Dead time Td (1 when dead time generation is disabled by the TDERA or TDERB setting)
TCBRA, TCBRB	1/2 PWM cycle
MTU3.TGRD, MTU4.TGRC, MTU4.TGRD MTU6.TGRD, MTU7.TGRC, MTU7.TGRD	Initial PWM duty ratio value for each phase
MTU3.TGRE, MTU4.TGRE, MTU4.TGRF MTU6.TGRE, MTU7.TGRE, MTU7.TGRF	Initial PWM duty ratio – 1 value for each phase (only when double buffer function is used)
MTU4.TCNT MTU7.TCNT	H'0000

Note: The value set in MTU3.TGRC (MTU6.TGRC) should be the sum of 1/2 the PWM cycle set in TCBRA (TCBRB) and dead time Td set in TDDRA (TDDRB). When dead time generation is disabled by TDERA (TDERB), TGRC should be set to 1/2 the PWM cycle + 1.

(d) PWM Output Level Setting

In complementary PWM mode, the PWM output level is set with bits OLSN and OLSP in timer output control register 1 (TOCR1A or TOCR1B) or bits OLS1P to OLS3P and OLS1N to OLS3N in timer output control register 2 (TOCR2A or TOCR2B).

The output level can be set for each of the three positive phases and three negative phases of 6-phase output. Complementary PWM mode should be cleared before setting or changing output levels.

(e) Dead Time Setting

In complementary PWM mode, dead time can be set for PWM output.

The dead time is set in the timer dead time data register (TDDRA or TDDRB). The value set in TDDRA (TDDRB) is used as the MTU3.TCNT (MTU6.TCNT) counter start value and creates a non-overlapping interval between MTU3.TCNT (MTU6.TCNT) and MTU4.TCNT (MTU7.TCNT). Complementary PWM mode should be cleared before changing the contents of TDDRA (TDDRB).

(f) Dead Time Suppressing

Dead time generation is suppressed by clearing the TDER bit in the timer dead time enable register (TDERA or TDERB) to 0. TDERA (TDERB) can be cleared to 0 only when 0 is written to it after reading TDER = 1.

MTU3.TGRA and MTU4.TGRC (MTU6.TGRA and MTU7.TGRC) should be set to 1/2 PWM cycle + 1 and the timer dead time data register (TDDRA or TDDRb) should be set to 1.

By the above settings, PWM waveforms without dead time can be obtained. **Figure 16.51** shows an example of operation without dead time (MTU3 and MTU4).

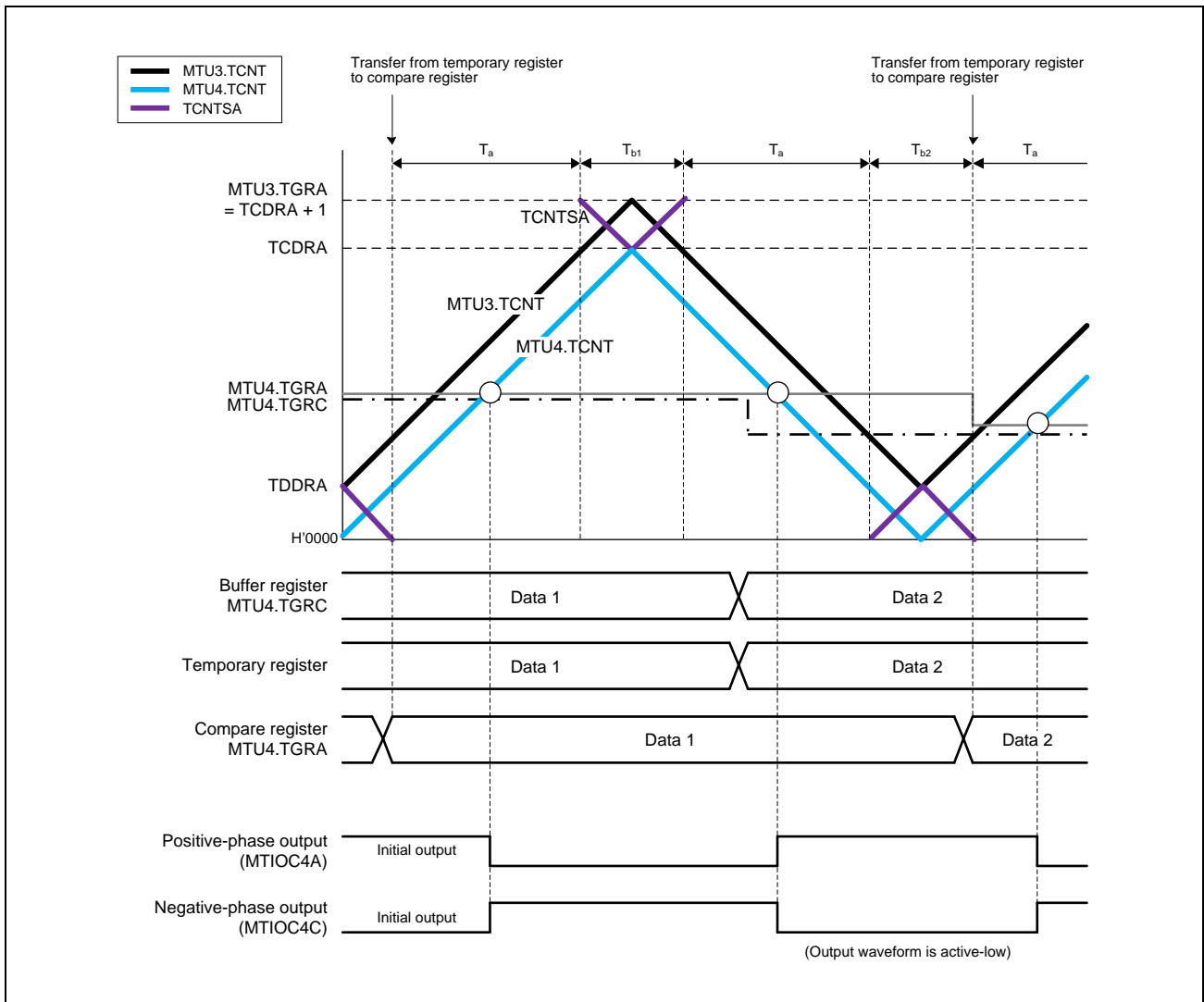

Figure 16.51 Example of Operation without Dead Time (MTU3 and MTU4)

(g) PWM Cycle Setting

In complementary PWM mode, the PWM cycle is set in two registers—MTU3.TGRA (MTU6.TGRA), in which the MTU3.TCNT (MTU6.TCNT) upper limit value is set, and TCDRA (TCDRB), in which the MTU4.TCNT (MTU7.TCNT) upper limit value is set. The settings should be made so as to achieve the following relationship between these two registers:

With dead time: MTU3.TGRA (MTU6.TGRA) setting = TCDRA (TCDRB) setting + TDDRA (TDDRB) setting

Without dead time: MTU3.TGRA (MTU6.TGRA) setting = TCDRA (TCDRB) setting + 1

In addition, the settings should be made so as to achieve the following relationship between the TCDRA (TCDRB) register and the TDDRA (TDDRB) register:

$TCDRA (TCDRB) \text{ setting} > TDDRA (TDDRB) \text{ setting} \times 2 + 2$

The MTU3.TGRA and TCDRA (MTU6.TGRA and TCDBR) settings are made by setting values in buffer registers MTU3.TGRC and TCBRA (MTU6.TGRC and TCBRB). When data is written to MTU4.TGRD (MTU7.TGRD) to enable transfers, the values set in MTU3.TGRC and TCBRA (MTU6.TGRC and TCBRB) are transferred simultaneously to the MTU3.TGRA and TCDRA (MTU6.TGRA and TCDBR) with the transfer timing selected with the MTU3.TMDR1.MD[3:0] (MTU6.TMDR1.MD[3:0]) bits.

The new PWM cycle is reflected from the next cycle when data is updated at the crest, or from the current cycle when updated in the trough. **Figure 16.52** illustrates the operation when the PWM cycle is updated at the crest.

See the following **Section 16.3.8(2)(h), Register Data Updating**, for the method of updating the data in each buffer register.

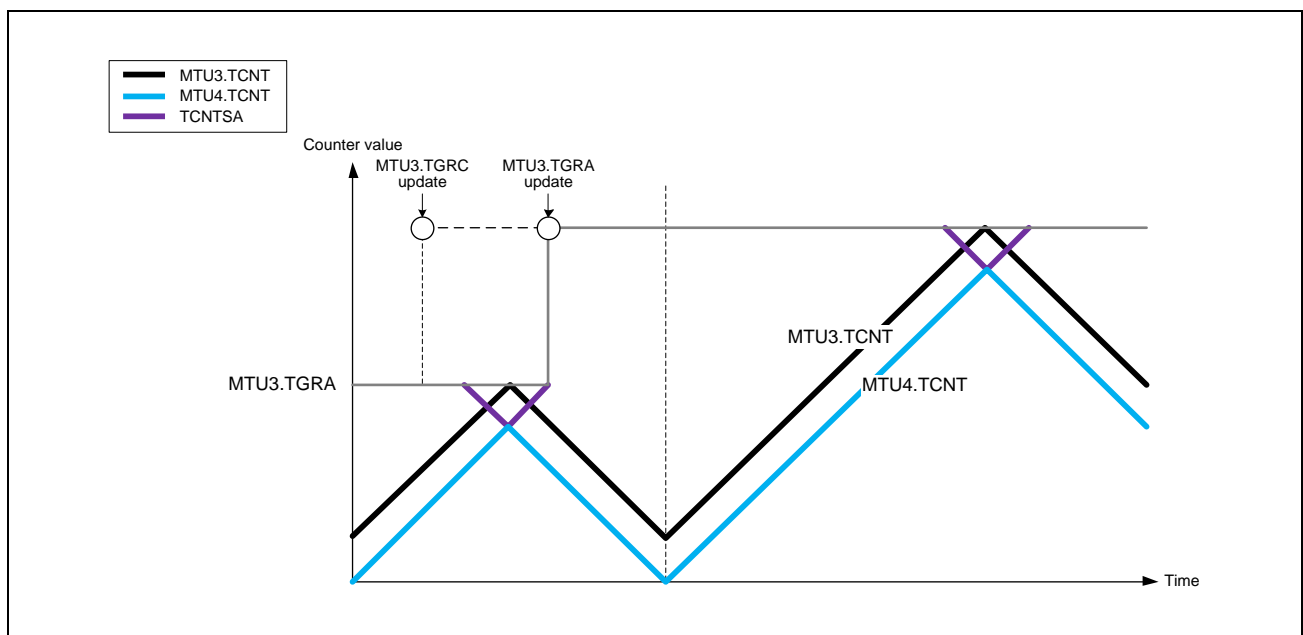

Figure 16.52 Example of PWM Cycle Updating (MTU3 and MTU4)

(h) Register Data Updating

In complementary PWM mode, buffer registers are used to update the data in five compare registers for PWM duty and PWM cycle. The update data can be written to the buffer registers at any time.

There is a temporary register between each of these registers and its buffer register. While subcounter TCNTSA (TCNTSB) is not counting, if buffer register data is updated, the temporary register value also changes. Data is not transferred from buffer registers to temporary registers while TCNTSA (TCNTSB) is counting; in this case, the value written to a buffer register is transferred after TCNTSA (TCNTSB) halts.

The temporary register value is transferred to the compare register at the data update timing set with MTU3.TMDR1.MD[3:0] (MTU6.TMDR1.MD[3:0]) bits. **Figure 16.53** shows an example of data updating in complementary PWM mode (MTU3 and MTU4). This example shows the mode in which data is updated at both the counter crest and trough.

When updating buffer register data, be sure to write to MTU4.TGRD (MTU7.TGRD) at the end of the update. Data is transferred from buffer registers to the temporary registers simultaneously for all five registers after the write to MTU4.TGRD (MTU7.TGRD).

Even when not updating all five registers or when not updating the MTU4.TGRD (MTU7.TGRD) data, be sure to write to MTU4.TGRD (MTU7.TGRD) after writing data to the registers to be updated. In this case, the data written to MTU4.TGRD (MTU7.TGRD) should be the same as the data prior to the write operation.

See **Section 16.3.8(2)(s), Double Buffer Function in Complementary PWM Mode**, for data updating when the double buffer function is used.

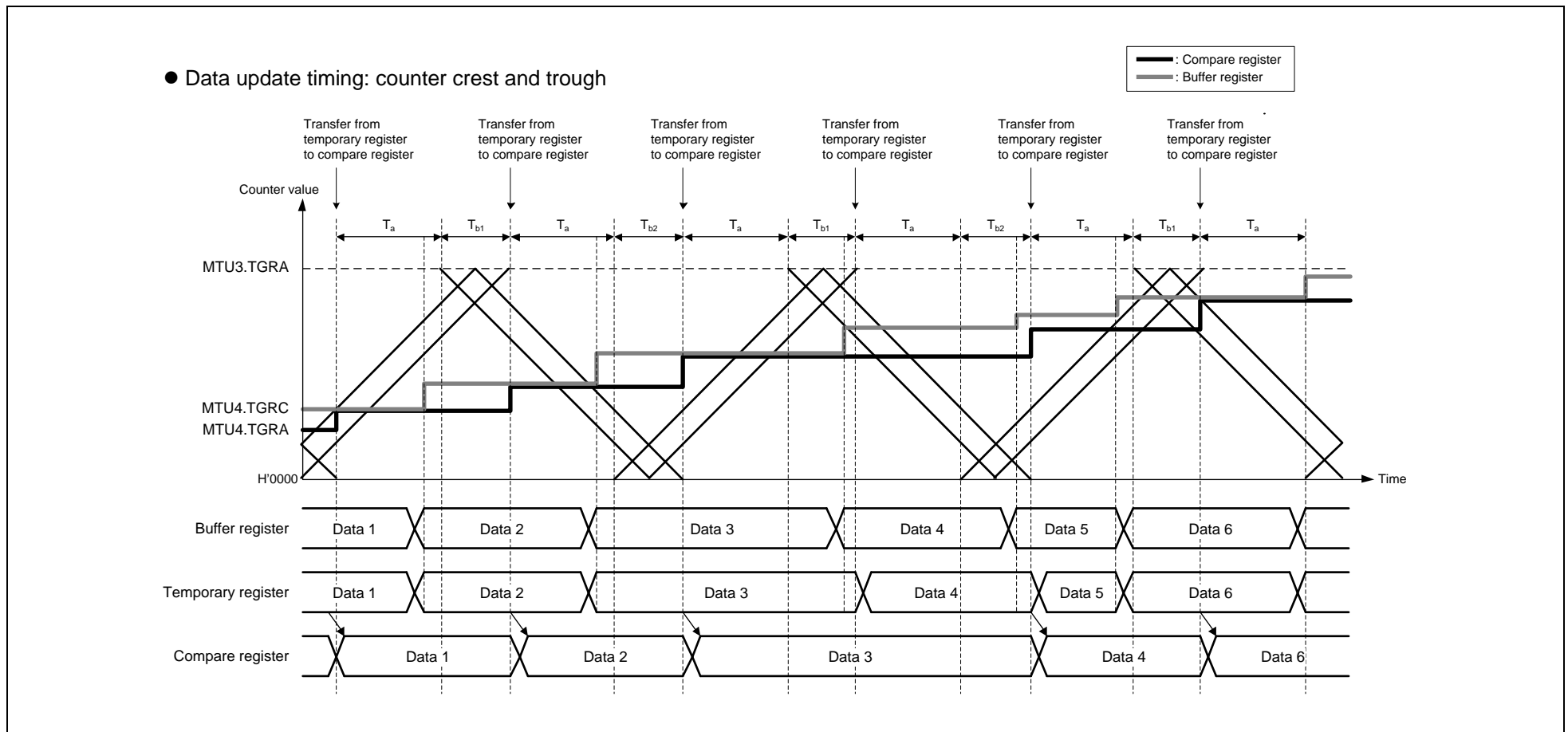

Figure 16.53 Example of Data Updating in Complementary PWM Mode (MTU3 and MTU4)

(i) Initial Output in Complementary PWM Mode

In complementary PWM mode, the initial output is determined by the setting of the OLSN and OLSP bits in the TOCR1A (TOCR1B) register or the OLS1N to OLS3N and OLS1P to OLS3P bits in the TOCR2A register (TOCR2B). This initial output is the non-active level of the PWM output and continues from when complementary PWM mode is set with the MTU3.TMDR1 (MTU6.TMDR1) until MTU4.TCNT (MTU7.TCNT) exceeds the value set in the TDDRA (TDDRB) register. **Figure 16.54** shows an example of the initial output in complementary PWM mode.

An example of the waveform when the initial PWM duty ratio value is smaller than the TDDRA (TDDRB) value is shown in **Figure 16.55**.

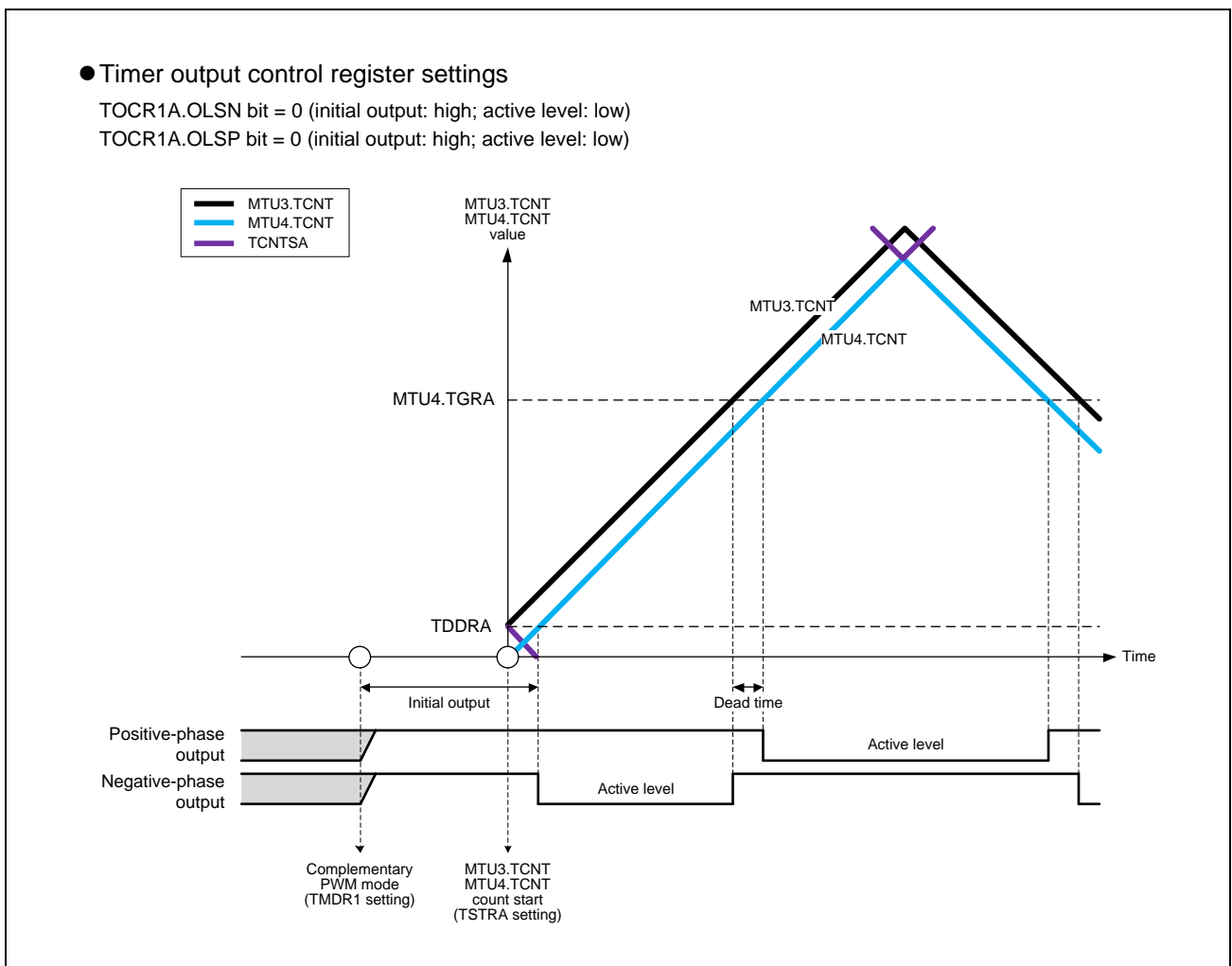

Figure 16.54 Example of Initial Output in Complementary PWM Mode (MTU3 and MTU4) (1)

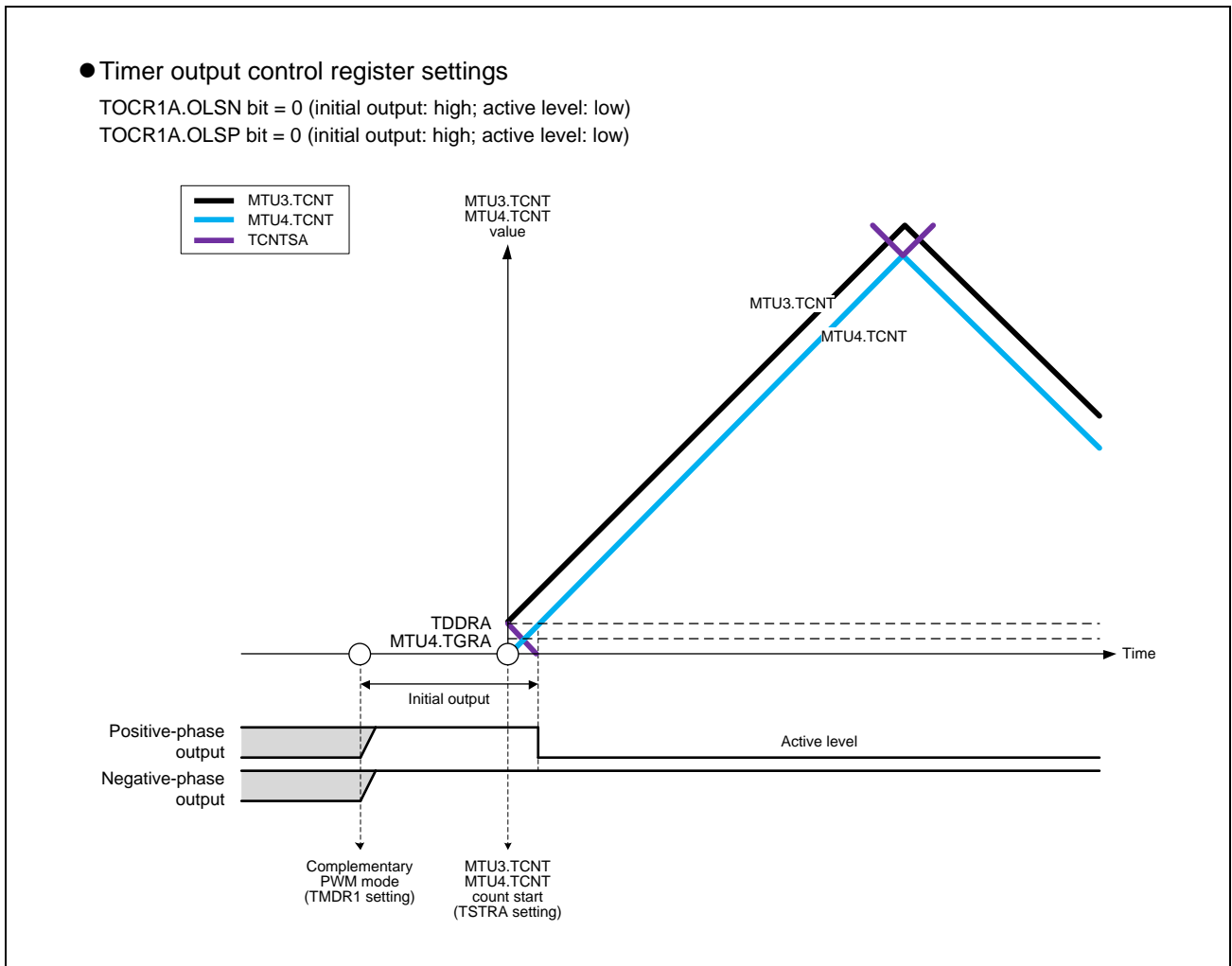

Figure 16.55 Example of Initial Output in Complementary PWM Mode (MTU3 and MTU4) (2)

(j) Method for Generating PWM Output in Complementary PWM Mode

In complementary PWM mode, six phases (three positive and three negative) PWM waveforms can be output. Dead time can be set for PWM waveforms to be output.

A PWM waveform is generated by output of the level selected in the timer output control register in the event of a compare match between a counter and a compare register. While TCNTSA (TCNTSB) is counting, the compare register and temporary register values are simultaneously compared to create consecutive PWM output from 0 to 100% duty ratio. The relative timing of turn-on and turn-off compare match occurrence may vary, but the compare match that turns off each phase takes precedence to secure the dead time and ensure that the positive-phase and negative-phase turn-on times do not overlap. **Figure 16.56** to **Figure 16.58** show examples of waveform generation in complementary PWM mode.

The positive-phase and negative-phase turn-off timing is generated by a compare match with the counter indicated by a solid line, and the turn-on timing is generated by a compare match with the counter indicated by a dotted line, which operates with a delay equal to the dead time behind the counter indicated by a solid line. In the T1 period, compare match a that turns off the negative phase has the highest priority, and compare matches before a are ignored. In the T2 period, compare match c that turns off the positive phase has the highest priority, and compare matches before c are ignored.

In most cases, compare matches occur in the order $a \rightarrow b \rightarrow c \rightarrow d$ (or $c \rightarrow d \rightarrow a' \rightarrow b'$) as shown in **Figure 16.56**.

If compare matches deviate from the $a \rightarrow b \rightarrow c \rightarrow d$ order, since the time for which the negative phase is off is shorter than twice the dead time, the positive phase is not turned on. If compare matches deviate from the $c \rightarrow d \rightarrow a' \rightarrow b'$ order, since the time for which the positive phase is off is shorter than twice the dead time, the negative phase is not turned on. As shown in **Figure 16.57**, if compare match c follows compare match a before compare match b, compare match b is ignored and the negative phase is turned on by compare match d. This is because turning off the positive phase has priority due to the occurrence of compare match c (positive-phase off timing) before compare match b (positive-phase on timing) (consequently, the waveform does not change because the positive phase goes from off to off).

Similarly, in the example in **Figure 16.58**, turning off the negative phase has priority due to the occurrence of compare match a' (negative-phase off timing) before compare match d (negative-phase on timing). As a result, the negative phase is not turned on.

Thus, in complementary PWM mode, compare matches at turn-off timings take precedence, and turn-on timing compare matches that occur before a turn-off timing compare match are ignored.

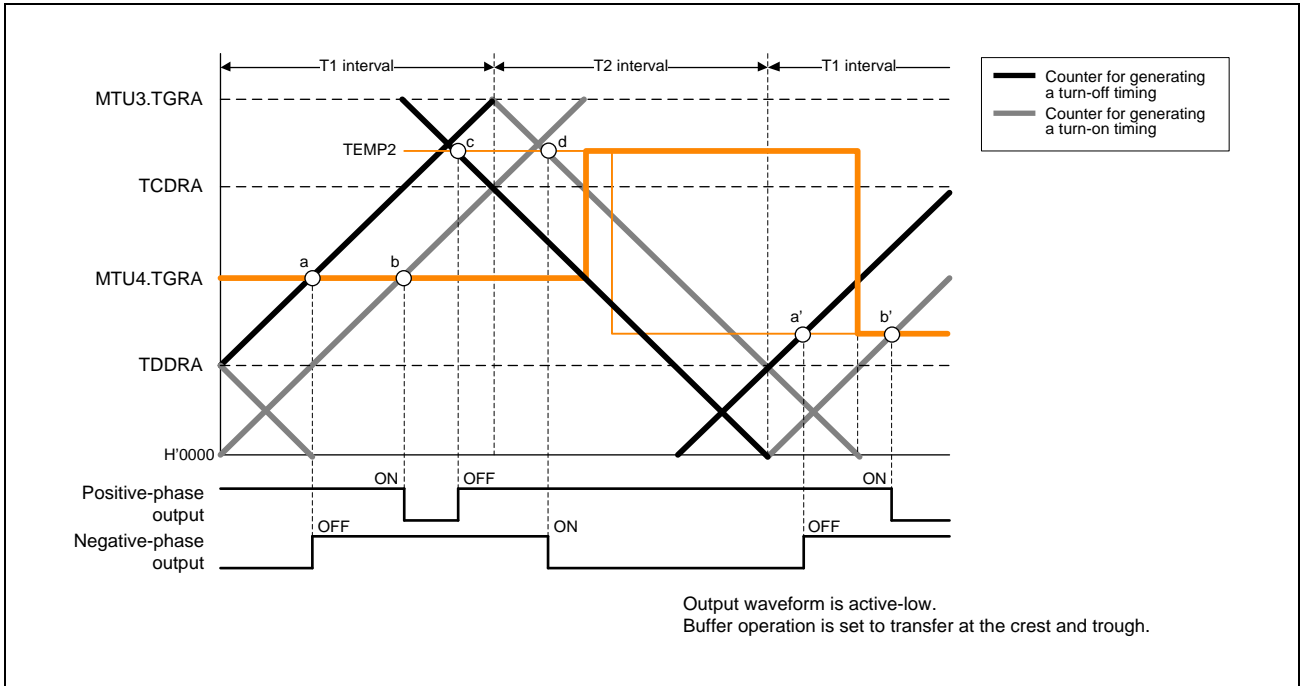

Figure 16.56 Example of Waveform Output in Complementary PWM Mode (MTU3 and MTU4) (1)

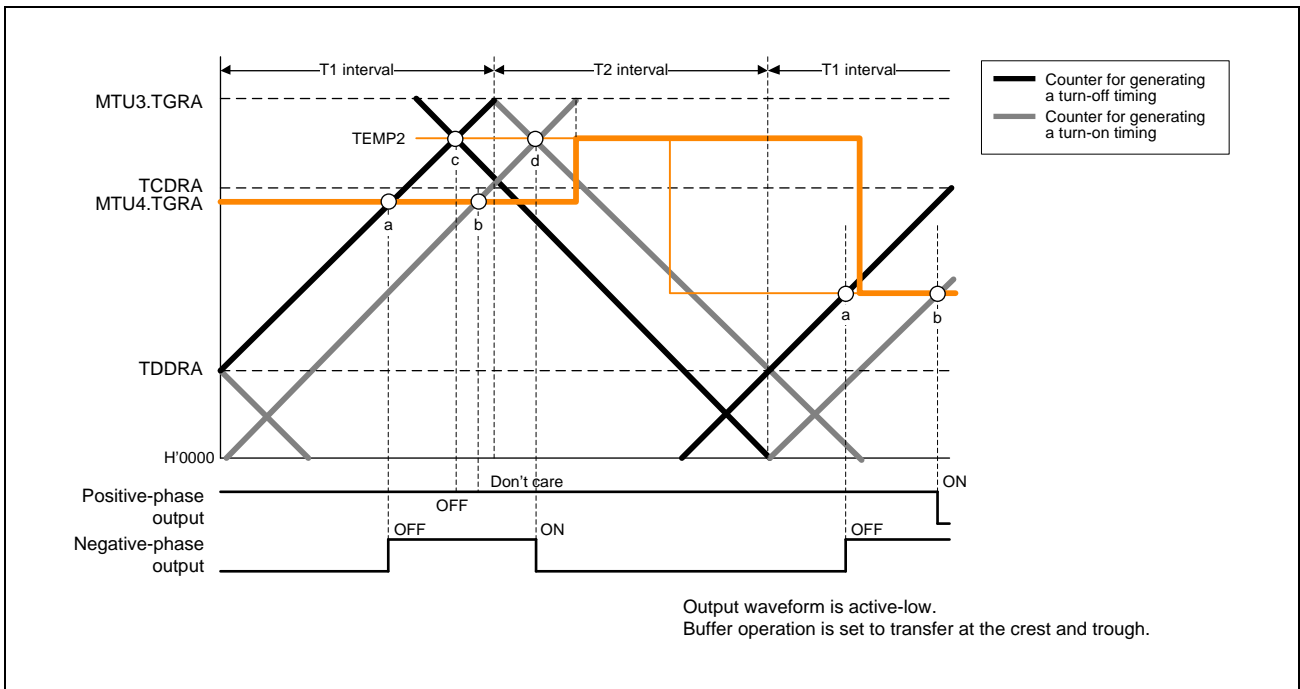

Figure 16.57 Example of Waveform Output in Complementary PWM Mode (MTU3 and MTU4) (2)

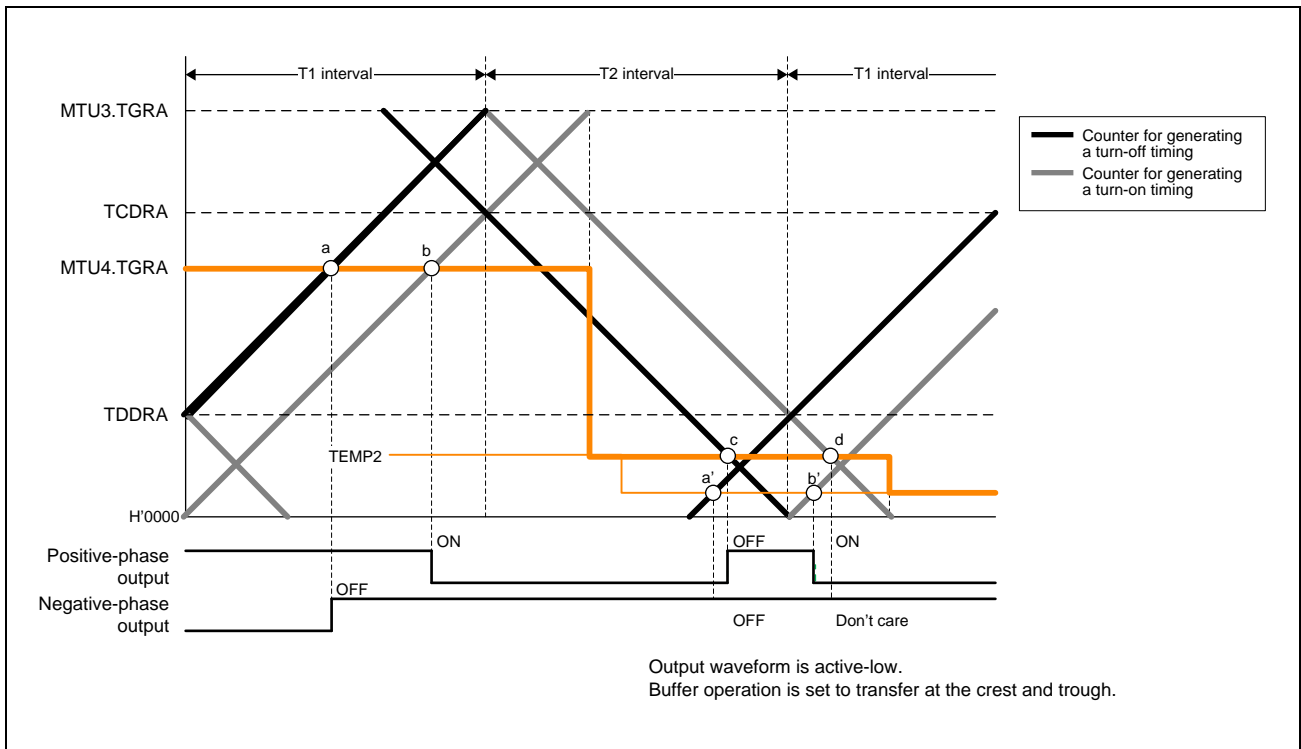

Figure 16.58 Example of Waveform Output in Complementary PWM Mode (MTU3 and MTU4) (3)

(k) 0% and 100% Duty Ratio Output in Complementary PWM Mode

In complementary PWM mode, 0% and 100% duty PWM output can be output as required. **Figure 16.59** to **Figure 16.63** show output examples.

A 100% duty waveform is output when the compare register value is set to H'0000. The waveform in this case has a positive phase with a 100% on-state. A 0% duty waveform is output when the compare register value is set to the same value as MTU3.TGRA (MTU6.TGRA). The waveform in this case has a positive phase with a 100% off-state.

Turn-on and turn-off compare matches occur simultaneously, but if a turn-on compare match and turn-off compare match for the same phase occur simultaneously, both compare matches are ignored and the waveform does not change.

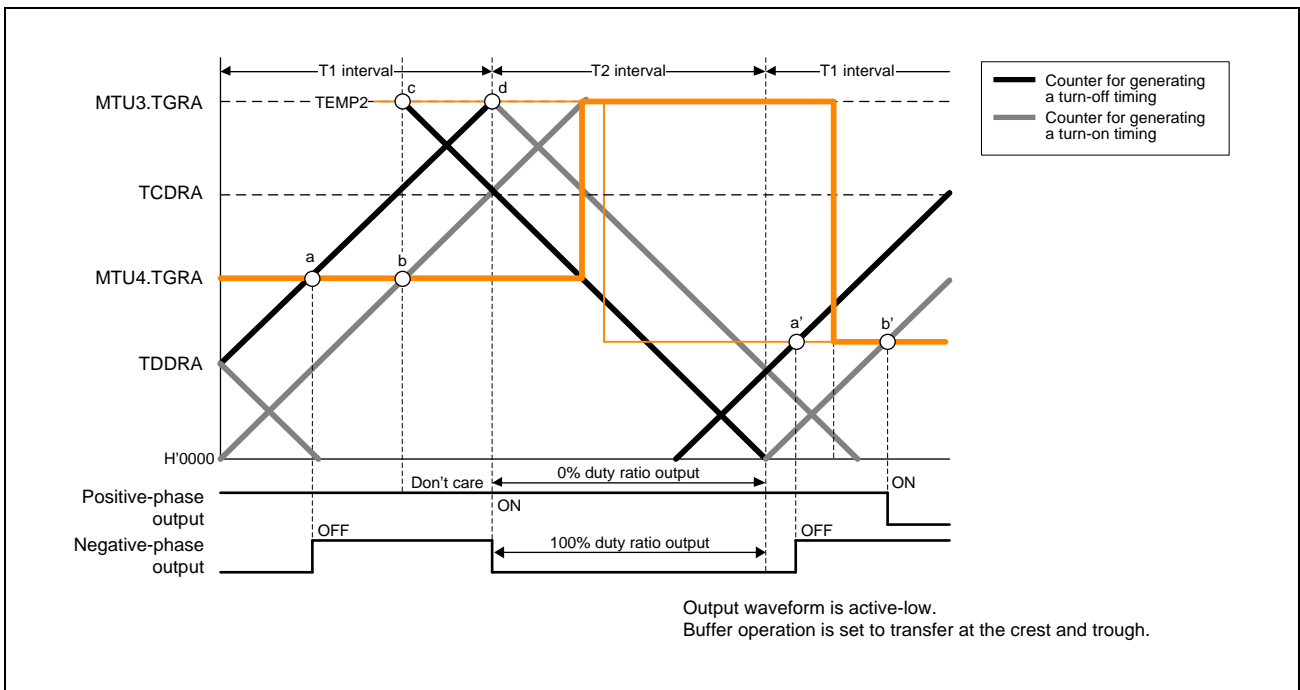

Figure 16.59 Example of 0% and 100% Waveform Output in Complementary PWM Mode (MTU3 and MTU4) (1)

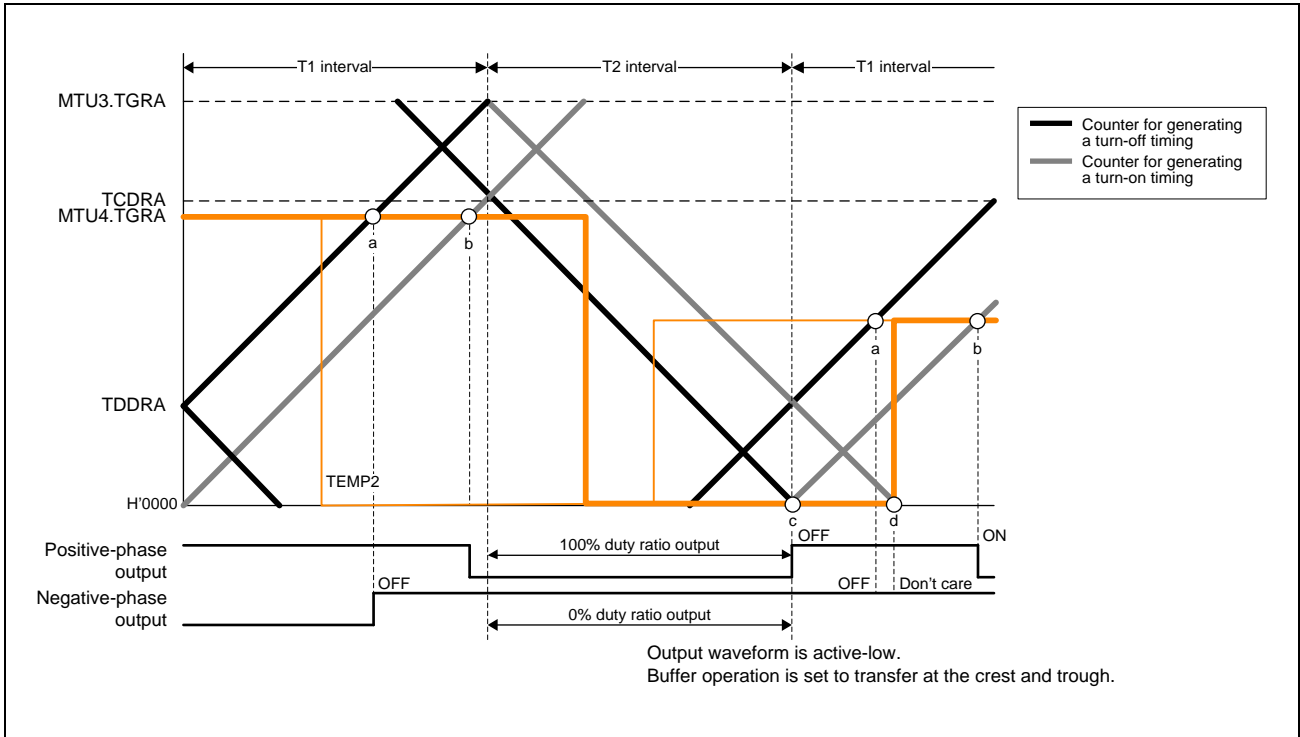

Figure 16.60 Example of 0% and 100% Waveform Output in Complementary PWM Mode (MTU3 and MTU4) (2)

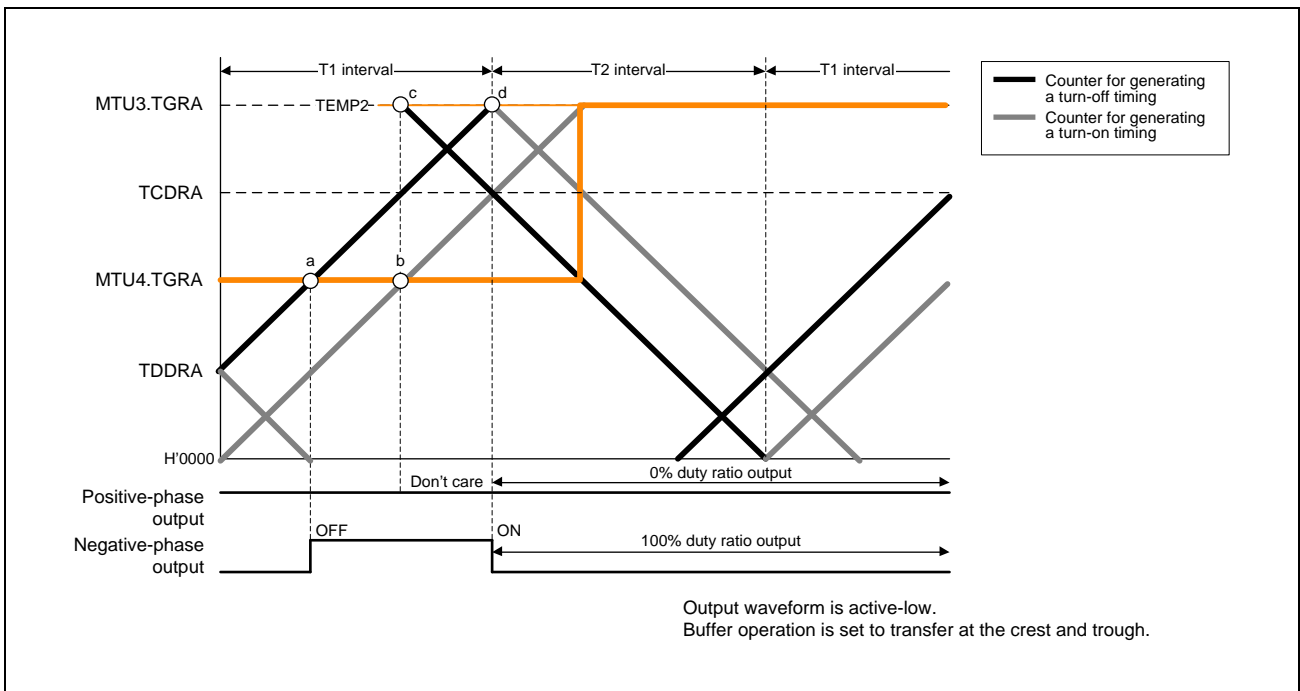

Figure 16.61 Example of 0% and 100% Waveform Output in Complementary PWM Mode (MTU3 and MTU4) (3)

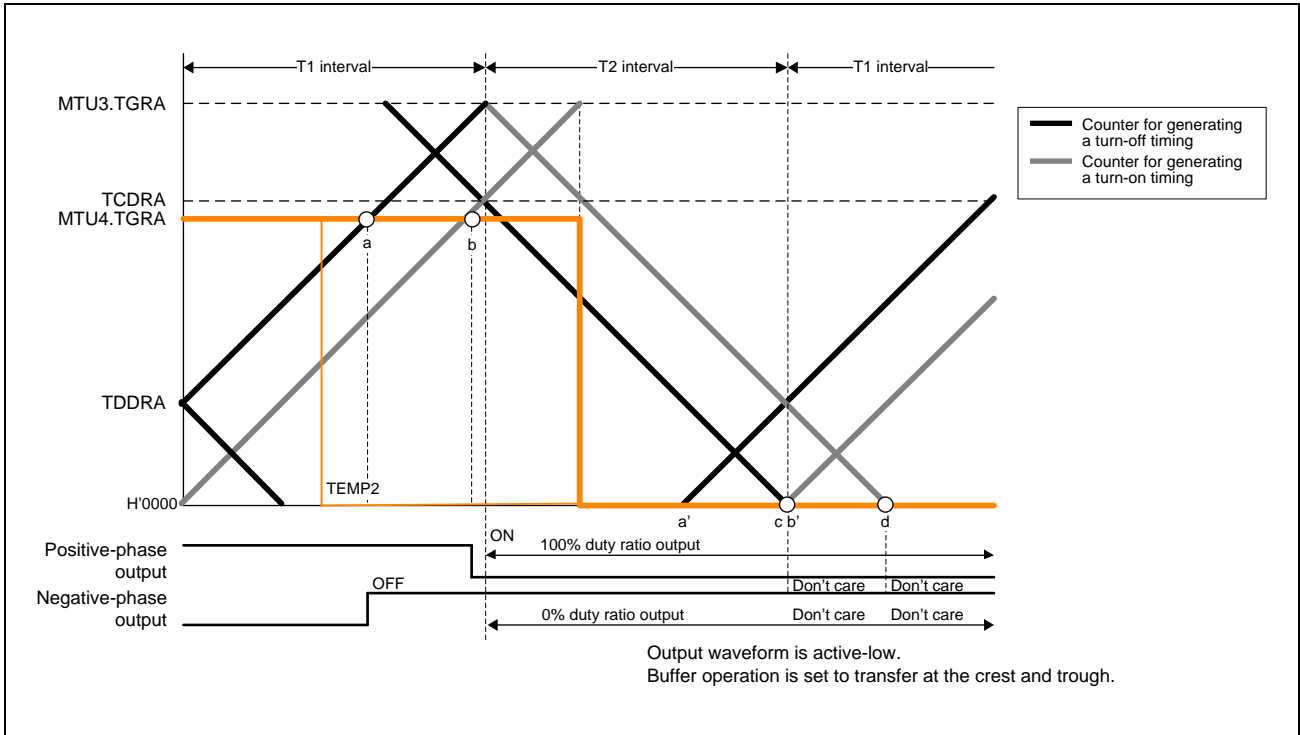

Figure 16.62 Example of 0% and 100% Waveform Output in Complementary PWM Mode (MTU3 and MTU4) (4)

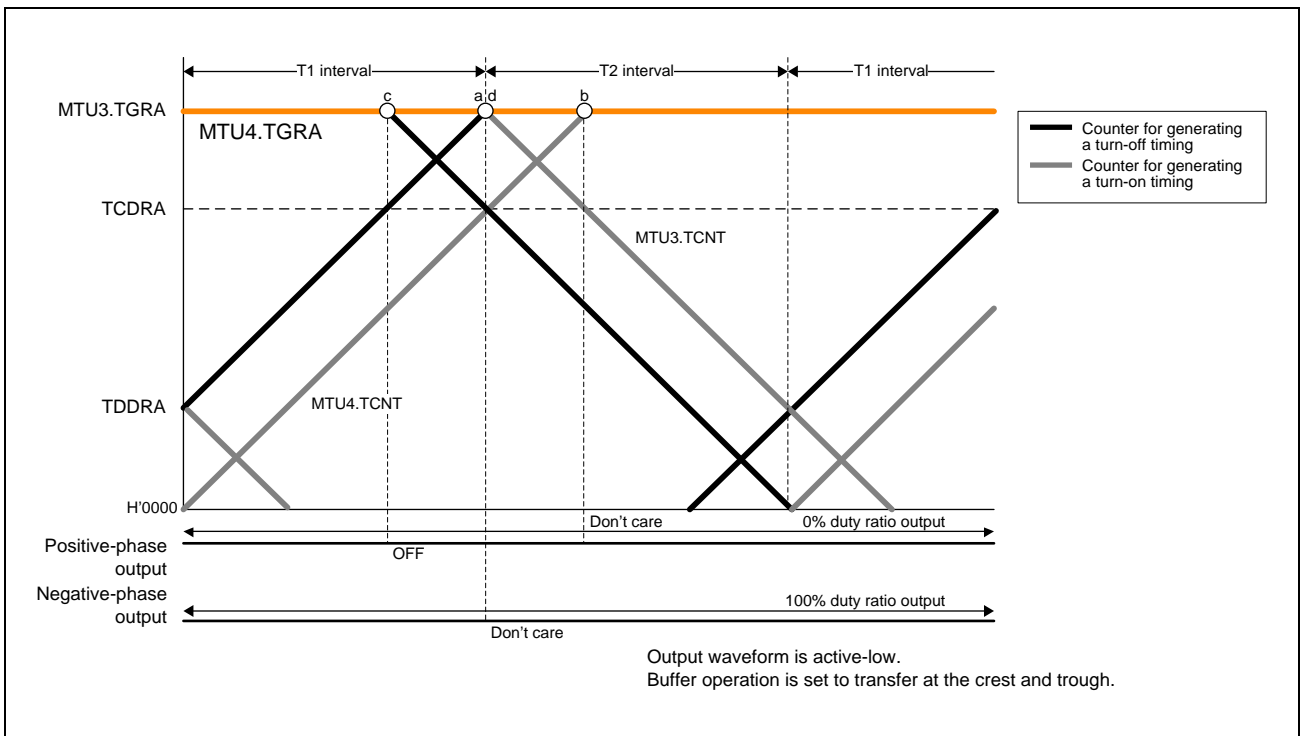

Figure 16.63 Example of 0% and 100% Waveform Output in Complementary PWM Mode (MTU3 and MTU4) (5)

(I) Toggle Output Synchronized with PWM Cycle

In complementary PWM mode, toggle output from the PWM output pin in synchronization with the PWM cycle can be enabled by setting the PSYE bit in the TOCR1A (TOCR1B) register to 1. An example of a toggle output waveform is shown in **Figure 16.64**.

This output is toggled by a compare match between MTU3.TCNT and MTU3.TGRA (MTU6.TCNT and MTU6.TGRA) and a compare match between MTU4.TCNT (MTU7.TCNT) and H'0000.

The MTIOC3A (MTIOC6A) pin is assigned for this toggle output. The initial output is high-level output.

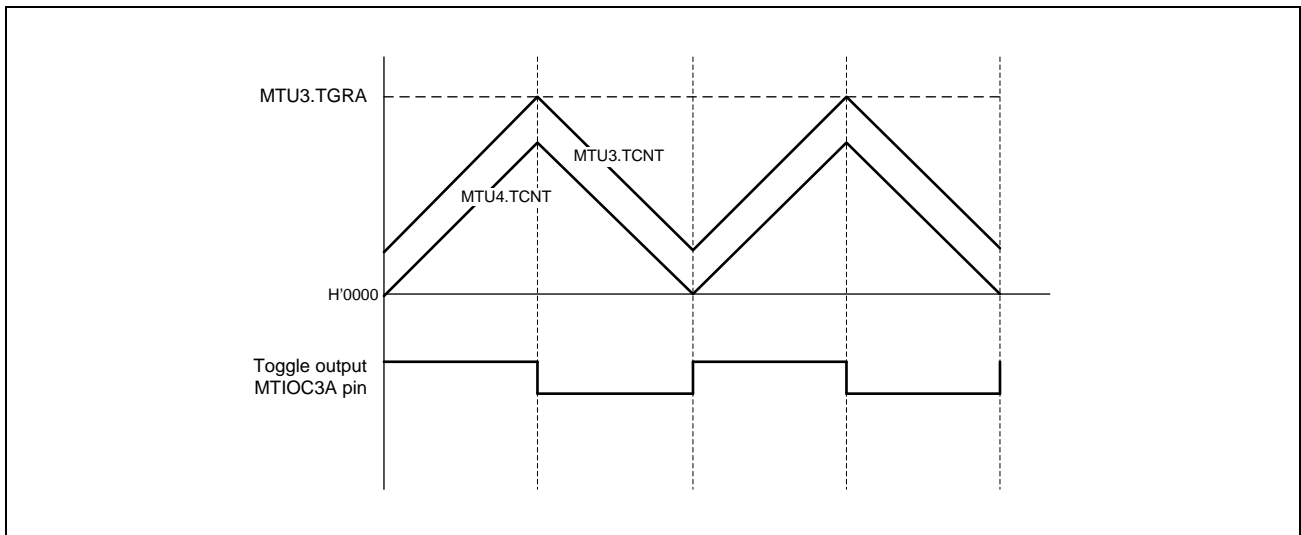

Figure 16.64 Example of Toggle Output Waveform Synchronized with PWM Output (MTU3 and MTU4)

(m) Counter Clearing by Another Channel

In complementary PWM mode, MTU3.TCNT, MTU4.TCNT, and TCNTSA (MTU6.TCNT, MTU7.TCNT, and TCNTSB) can be cleared by another channel source when a mode for synchronization with another channel is specified through the TSYRA (TSYRB) register and synchronous clearing is selected with MTU3.TCR.CCLR[2:0] (MTU6.TCR.CCLR[2:0]) bits.

Figure 16.65 illustrates an example of this operation.

Use of this function enables a counter to be cleared and restarted through an external signal.

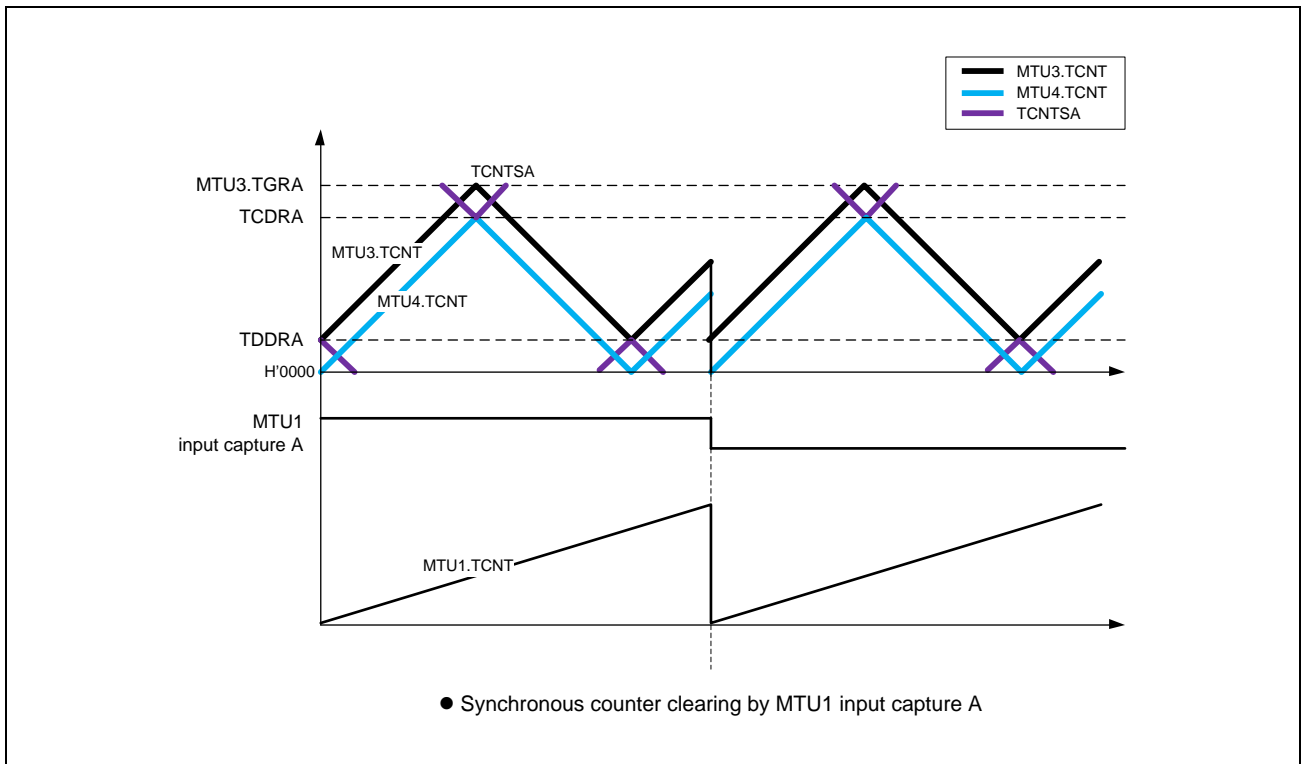

Figure 16.65 Counter Clearing Synchronized with Another Channel (MTU3 and MTU4)

(n) Output Waveform Control at Synchronous Counter Clearing in Complementary PWM Mode

Setting the WRE bit in TWCRA (TWCRA) to 1 suppresses initial output when synchronous counter clearing occurs in the T_b interval (T_{b2} interval) at the trough in complementary PWM mode and controls abrupt change in duty cycle at synchronous counter clearing.

Initial output suppression through the WRE bit = 1 is applicable only when synchronous clearing occurs in the T_b interval as indicated by (10) or (11) in **Figure 16.66**. When synchronous clearing occurs outside that interval, the initial value specified by the OLSN and OLSP bits in TOCR1A (TOCR1B) is output. Even in the T_b interval, if synchronous clearing occurs in the initial value output period (indicated by (1) in **Figure 16.66**) immediately after the counters start operation, initial value output is not suppressed.

This function can be used in both channel combinations of MTU 3 and MTU4 and MTU6 and MTU7. In MTU3 and MTU4, synchronous clearing in MTU0, MTU1, and MTU2 can cause counter clearing; in MTU6 and MTU7, compare match or input capture generated in MTU0, MTU1, and MTU2 can cause counter clearing.

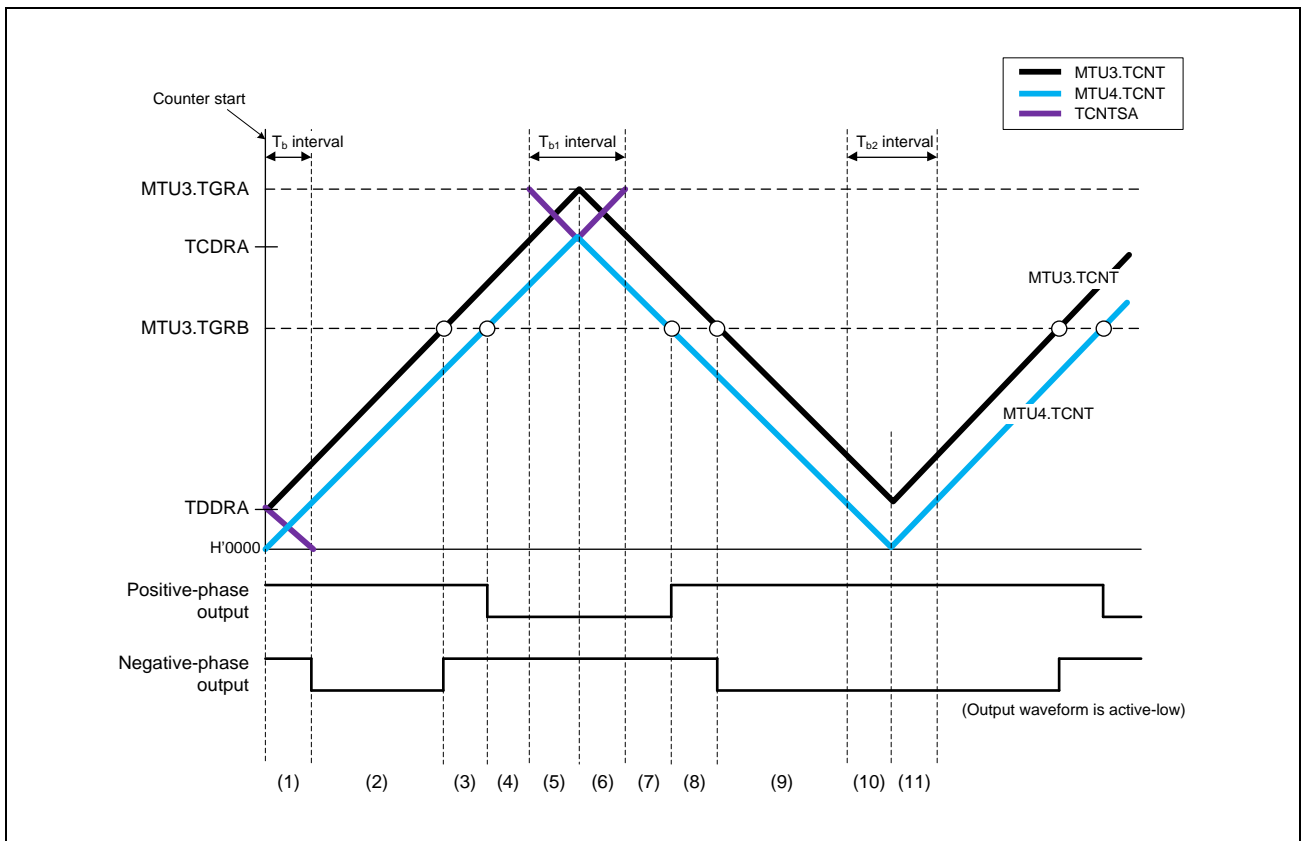

Figure 16.66 Timing for Synchronous Counter Clearing (MTU3 and MTU4)

- Example of Procedure for Setting Output Waveform Control at Synchronous Counter Clearing in Complementary PWM Mode.

An example of the procedure for setting output waveform control at synchronous counter clearing in complementary PWM mode is shown in **Figure 16.67**.

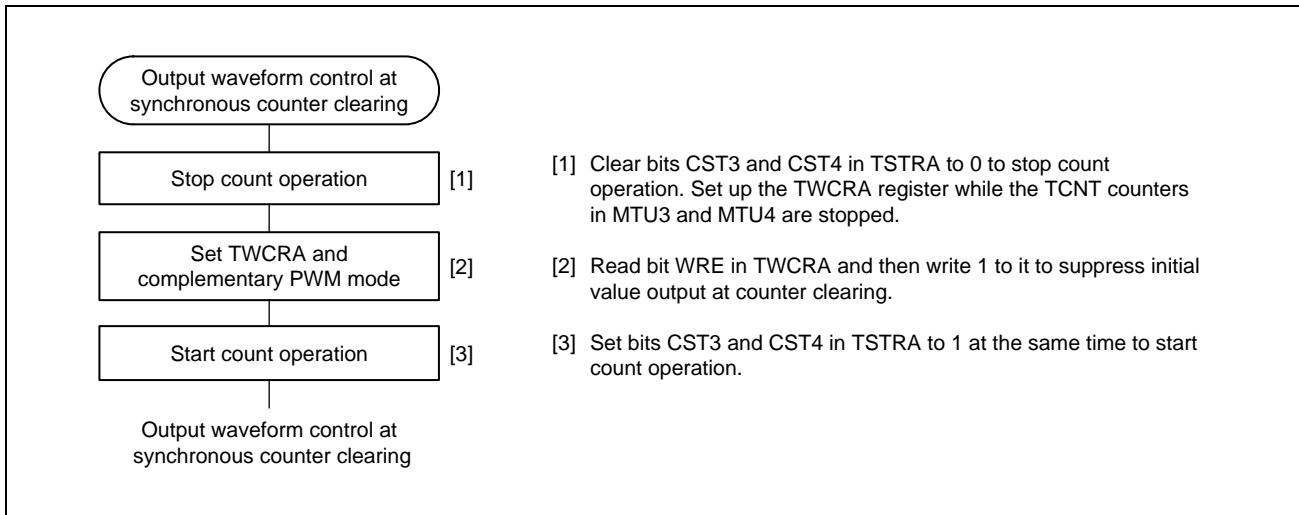

Figure 16.67 Example of Procedure for Setting Output Waveform Control at Synchronous Counter Clearing in Complementary PWM Mode (MTU3 and MTU4)

- Examples of Output Waveform Control at Synchronous Counter Clearing in Complementary PWM Mode

Figure 16.68 to **Figure 16.71** show examples of output waveform control in which MTU3 and MTU4 operate in complementary PWM mode and synchronous counter clearing is generated while the WRE bit in TWCRA is set to 1. In the examples shown in **Figure 16.68** to **Figure 16.71**, synchronous counter clearing occurs at timing (3), (6), (8), and (11) shown in **Figure 16.66**, respectively.

In MTU6 and MTU7, these examples are equivalent to the cases when MTU6 and MTU7 operate in complementary PWM mode and synchronous counter clearing is generated while the SCC bit is cleared to 0 and the WRE bit is set to 1 in TWCRB.

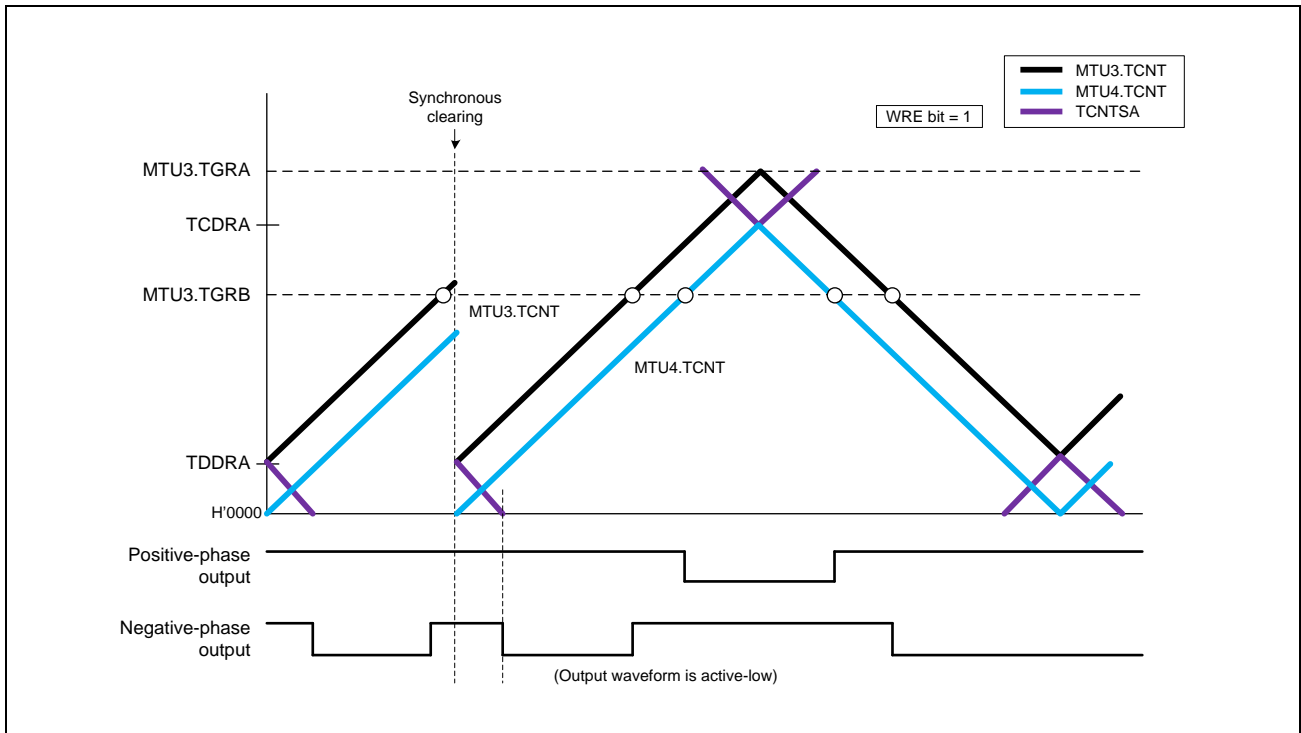

Figure 16.68 Example of Synchronous Clearing in Dead Time during Up-Counting (Timing (3) in **Figure 16.66**; TWCRA.WRE Bit is 1)

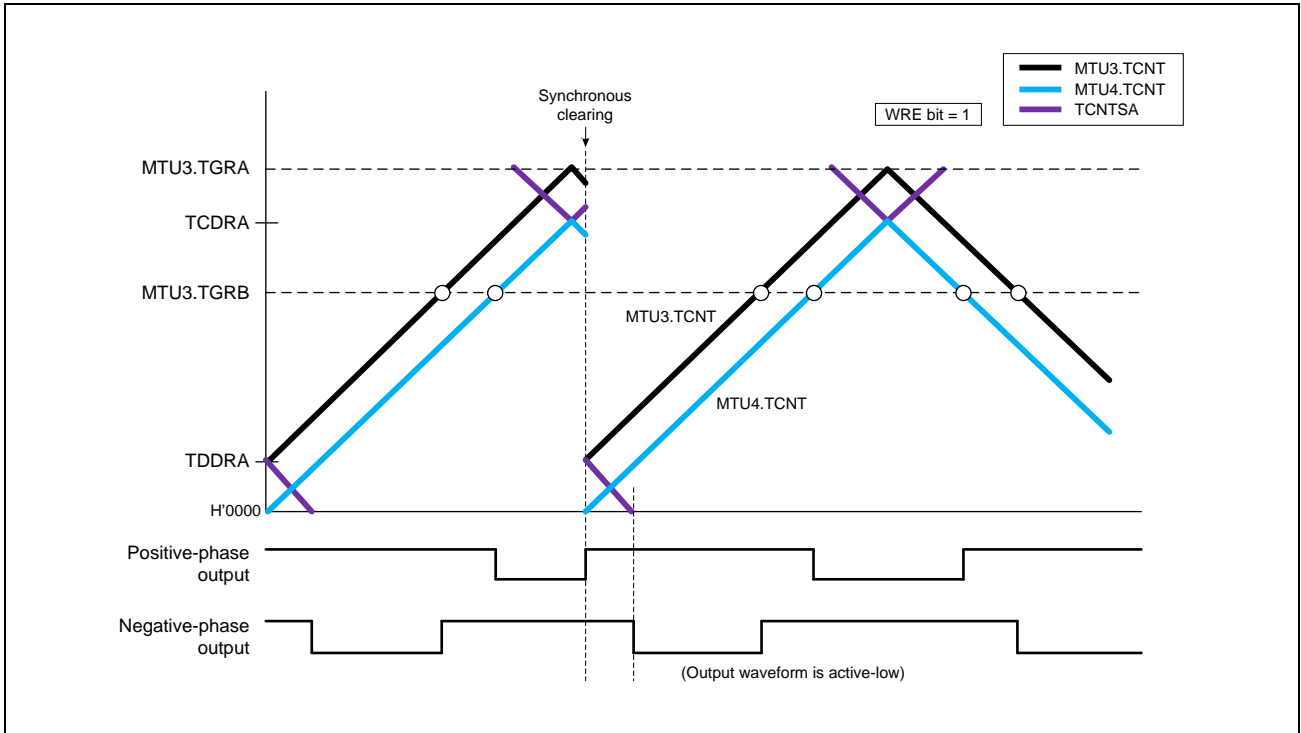

Figure 16.69 Example of Synchronous Clearing in Tb1 interval
(Timing (6) in Figure 16.66; TWCRA.WRE Bit is 1)

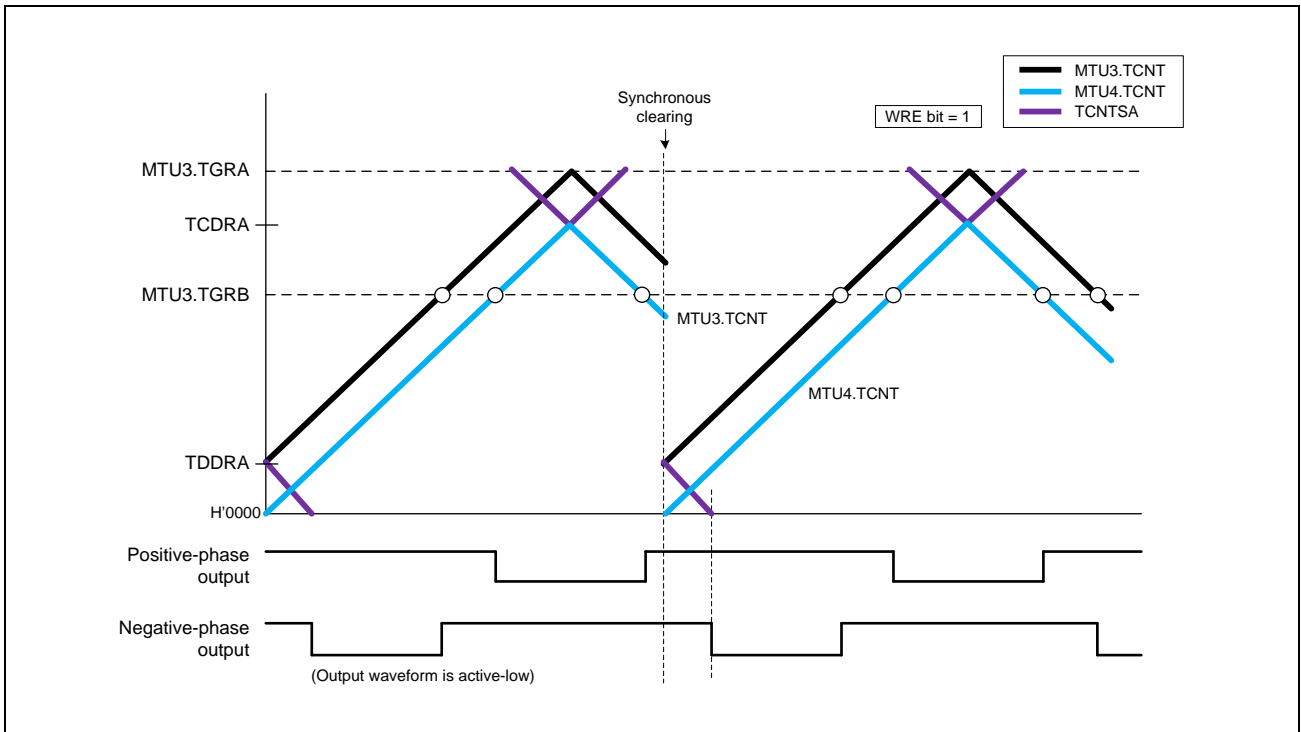

Figure 16.70 Example of Synchronous Clearing in Dead Time during Down-Counting
(Timing (8) in Figure 16.66; TWCRA.WRE Bit is 1)

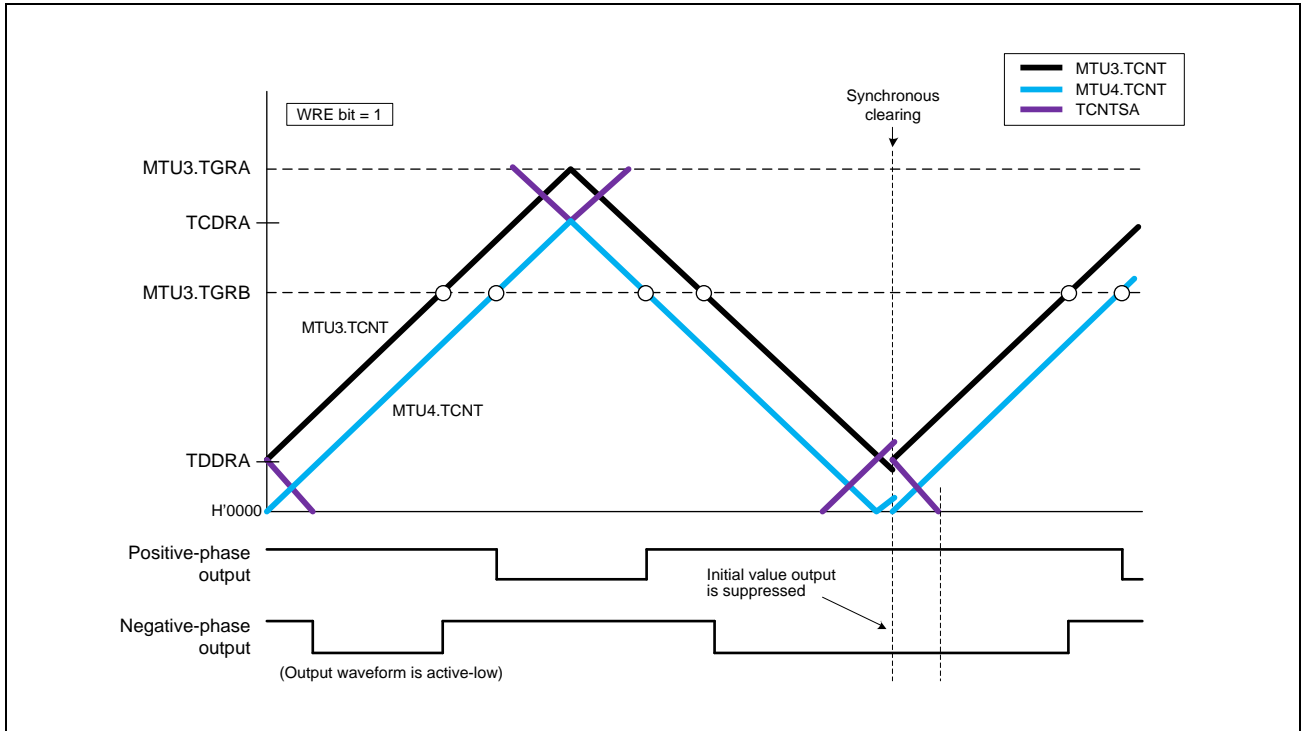

Figure 16.71 Example of Synchronous Clearing in Tb2 interval
(Timing (11) in **Figure 16.66**; TWCRA.WRE Bit is 1)

(o) Suppressing Synchronous Counter Clearing for MTU0 to MTU2 and MTU6 and MTU7

In MTU6 and MTU7, setting the SCC bit in TWCRB to 1 suppresses synchronous counter clearing caused by MTU0 to MTU2.

Synchronous counter clearing is suppressed only within the interval shown in **Figure 16.72**. When using this function, MTU6 and MTU7 should be set to complementary PWM mode.

For details of synchronous clearing caused by MTU0 to MTU2, refer to **Section 16.3.10(2), Synchronous Counter Clearing for MTU6 and MTU7**.

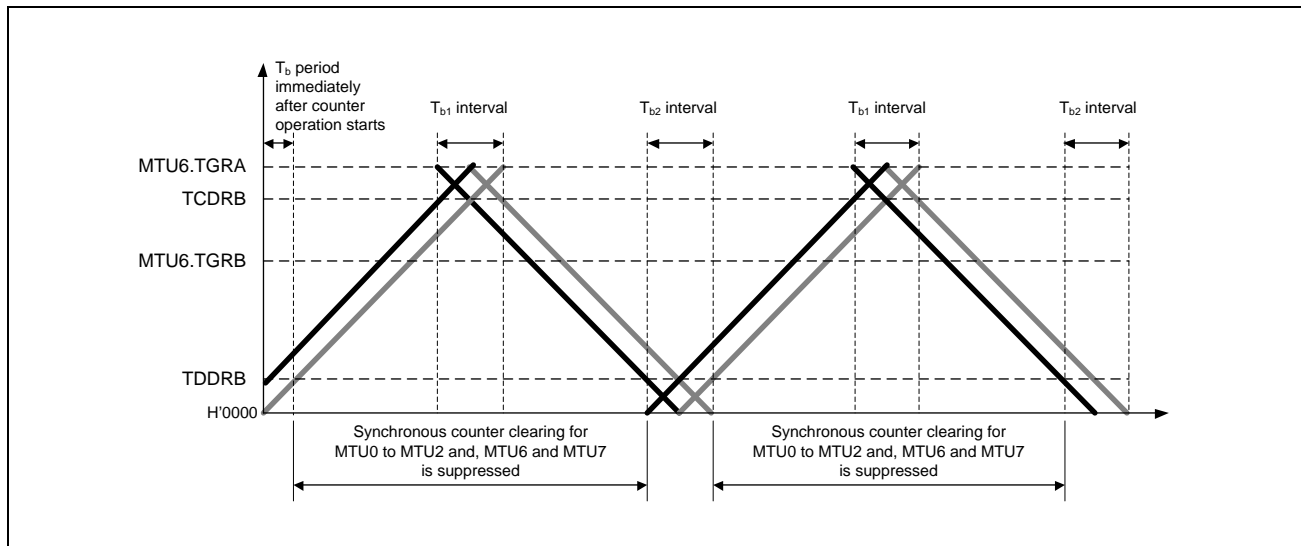

Figure 16.72 Synchronous Clearing-Suppressed Interval Specified by TWCRB.SCC Bit for MTU0, MTU1 and MTU2, and MTU6 and MTU7

- Example of Procedure for Suppressing Synchronous Counter Clearing for MTU0 to MTU2, and MTU6 and MTU7

An example of the procedure for suppressing synchronous counter clearing for MTU0 to MTU2, and MTU6 and MTU7 is shown in **Figure 16.73**.

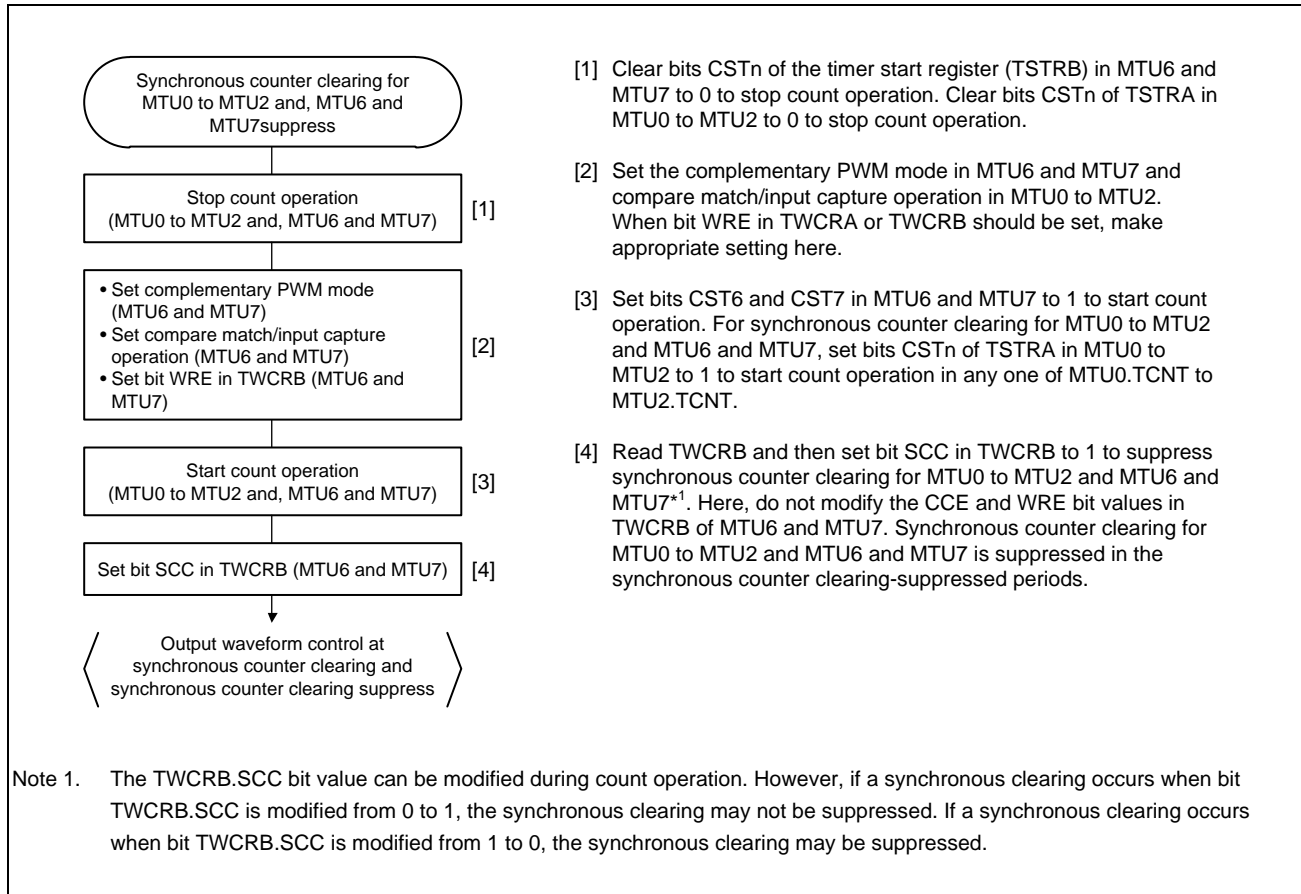

Figure 16.73 Example of Procedure for Suppressing Synchronous Counter Clearing for MTU0 to MTU2, and MTU6 and MTU7

- Examples of Suppression of Synchronous Counter Clearing for MTU 0 to MTU2, and MTU6 and MTU7

Figure 16.74 to Figure 16.77 show examples of operation in which MTU6 and MTU7 operate in complementary PWM mode and synchronous counter clearing for MTU 0 to MTU2, and MTU6 and MTU7 is suppressed by setting the SCC bit in TWCRB in MTU6 and MTU7 to 1. In the examples shown in Figure 16.74 to Figure 16.77, synchronous counter clearing occurs at timing (3), (6), (8), and (11) shown in Figure 16.66, respectively. In these examples, the WRE bit in TWCRB in MTU6 and MTU7 is set to 1.

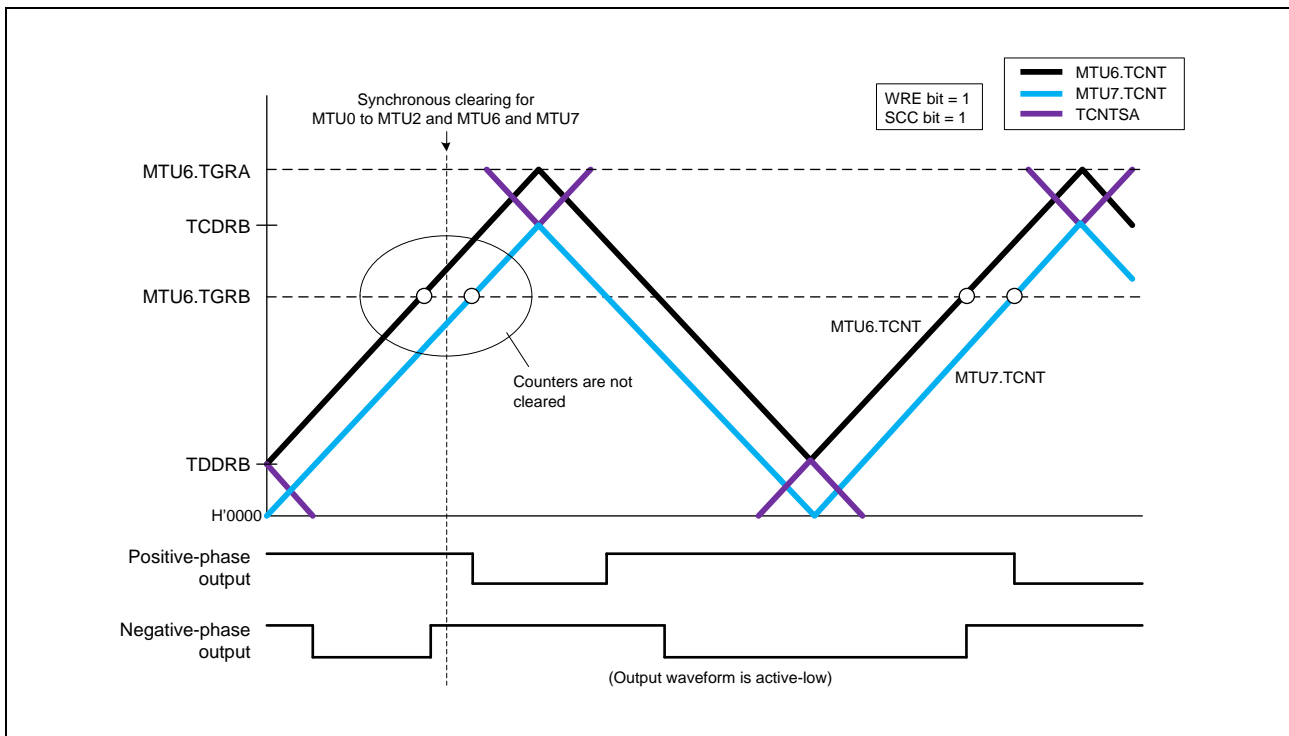

Figure 16.74 Example of Synchronous Clearing in Dead Time during Up-Counting (Timing (3) in Figure 16.66; TWCRB.WRE Bit is 1 and SCC Bit is 1 in MTU6 and MTU7)

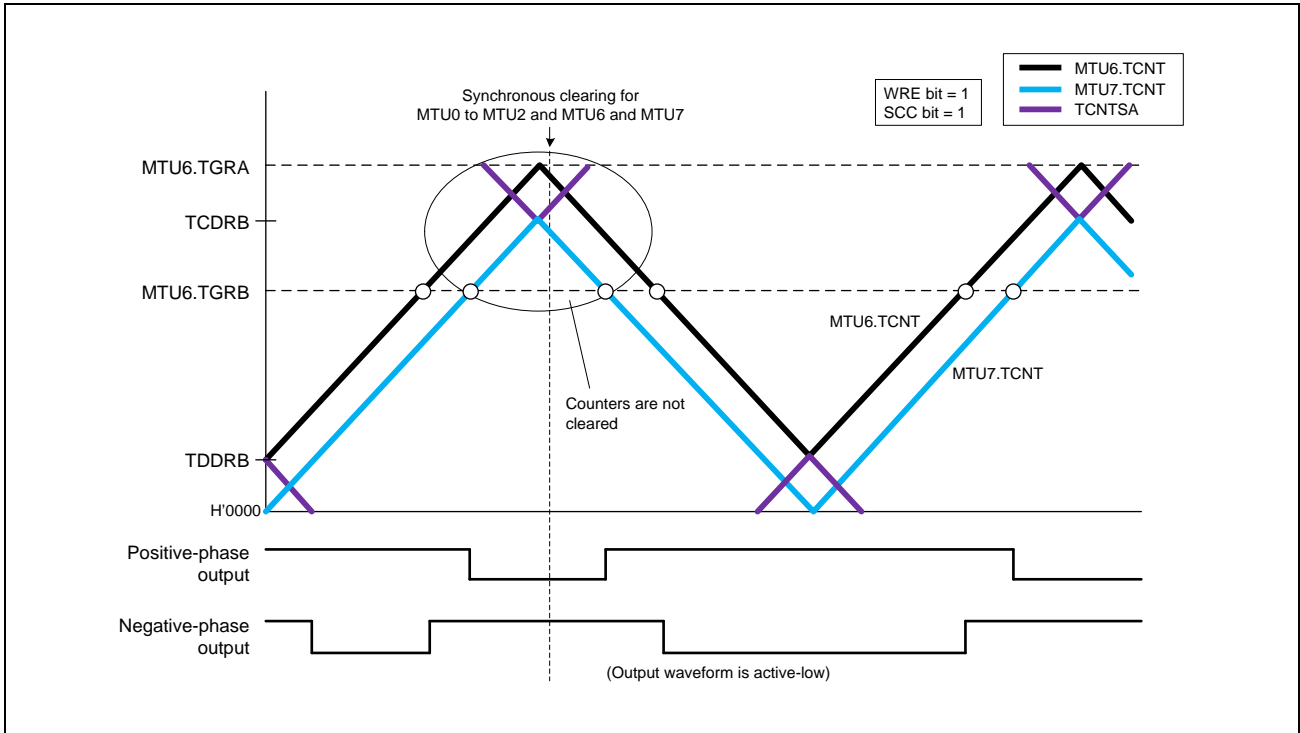

Figure 16.75 Example of Synchronous Clearing in Tb1 interval
(Timing (6) in Figure 16.66; TWCRB.WRE Bit is 1 and SCC Bit is 1 in MTU6 and MTU7)

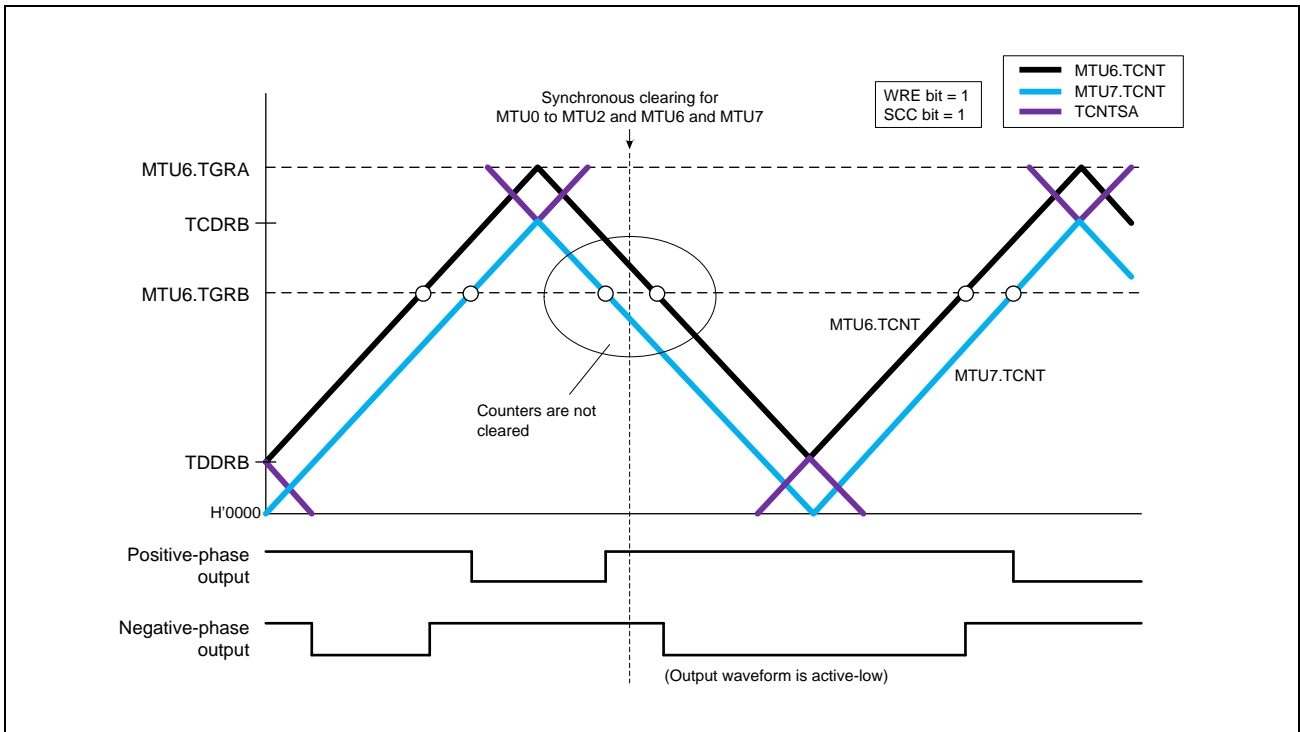

Figure 16.76 Example of Synchronous Clearing in Dead Time during Down-Counting
(Timing (8) in Figure 16.66; TWCRB.WRE Bit is 1 and SCC Bit is 1 in MTU6 and MTU7)

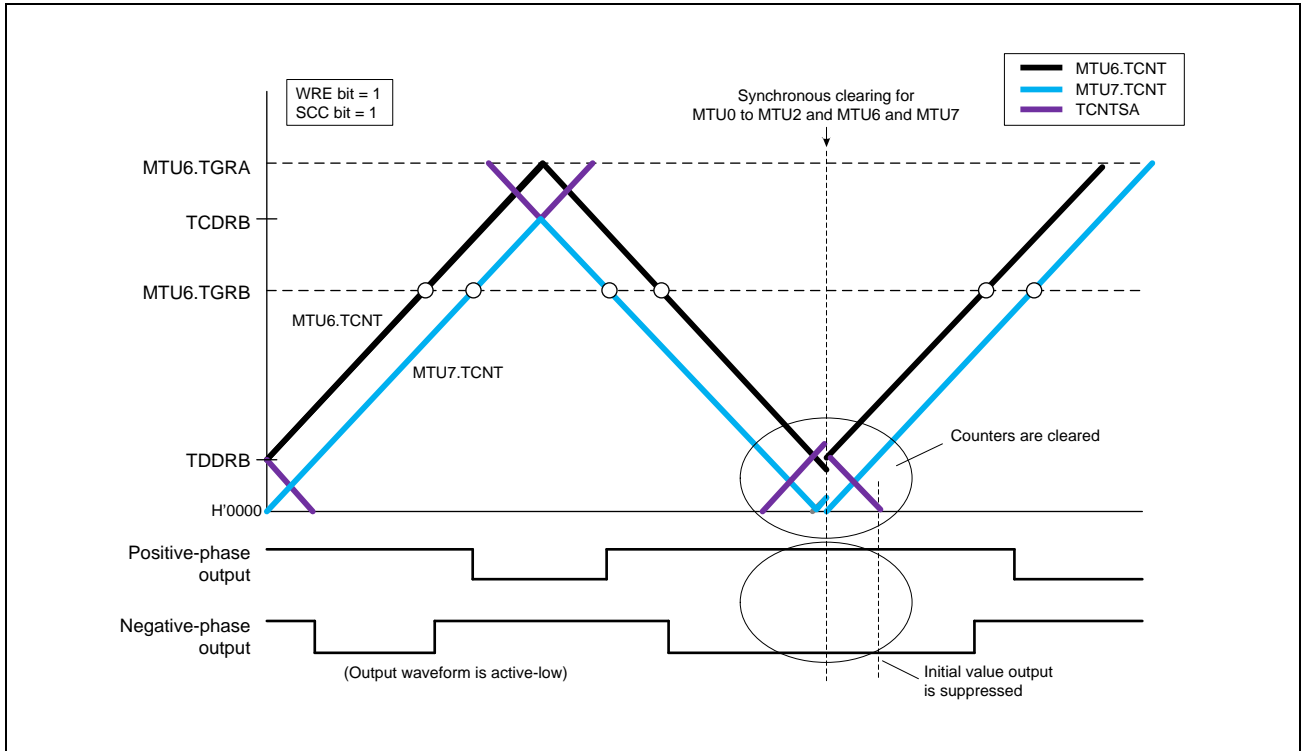

Figure 16.77 Example of Synchronous Clearing in Tb2 interval
(Timing (11) in **Figure 16.66**; TWCRB.WRE Bit is 1 and SCC Bit is 1 in MTU6 and MTU7)

(p) Counter Clearing by MTU3.TGRA (MTU6.TGRA) Compare Match

In complementary PWM mode, MTU3.TCNT, MTU4.TCNT, and TCNTSA (MTU6.TCNT, MTU7.TCNT, and TCNTSB) can be cleared by MTU3.TGRA (MTU6.TGRA) compare match when the TWCRA.CCE (TWCRB.CCE) bit.

Figure 16.78 illustrates an operation example.

NOTES

1. Use this function only in complementary PWM mode 1 (transfer at crest).
2. Do not specify synchronous clearing by another channel (do not set 1 in the SYNC0 to SYNC4 or SYNC6 to SYNC7 bits in the timer synchronous register (TSYRA or TSYRB) and the CEOA to CEOD or CEIA to CEID bits in TSYCR).
3. Do not set the PWM duty value to H'0000.
4. Do not set the PSYE bit in timer output control register 1 (TOCR1A or TOCR1B) to 1.

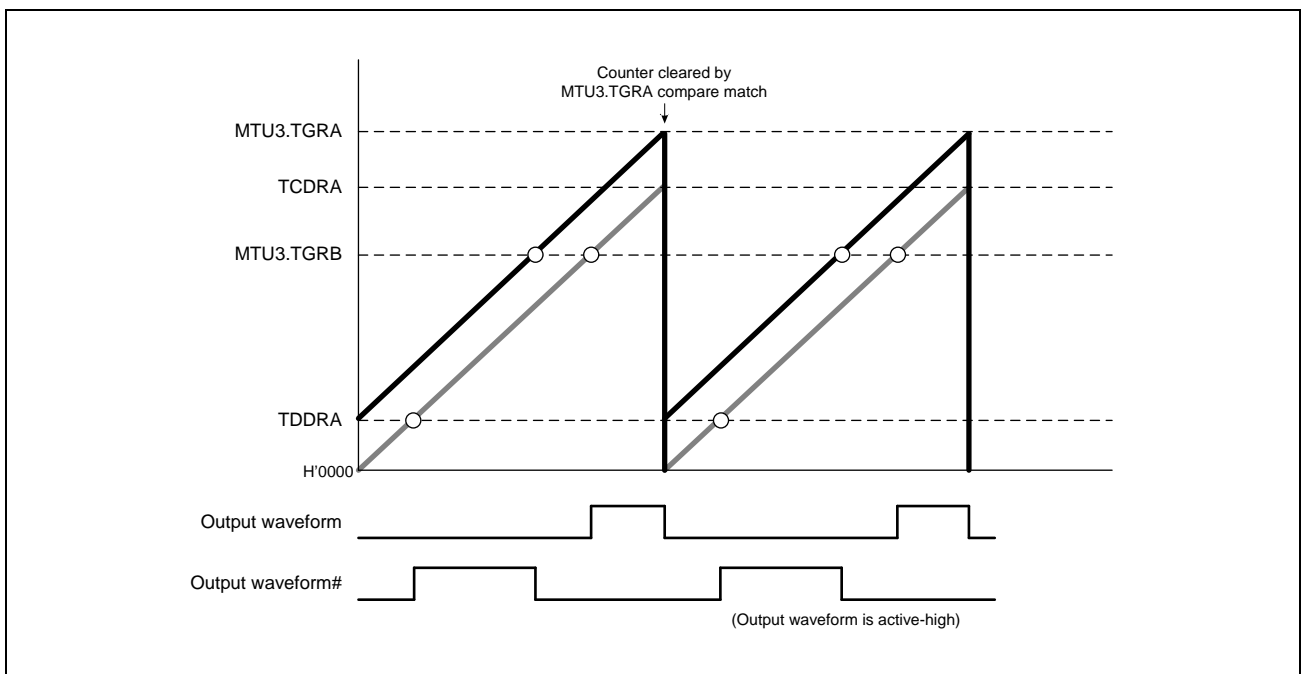

Figure 16.78 Example of Counter Clearing Operation by MTU3.TGRA Compare Match

(g) Example of Waveform Output for Driving AC Synchronous Motor (Brushless DC Motor)

In complementary PWM mode when MTU3 and MTU4 are used, a brushless DC motor can easily be controlled using TGCRA. **Figure 16.79** to **Figure 16.82** show examples of brushless DC motor driving waveforms created using TGCRA.

To switch the output phases for a 3-phase brushless DC motor by means of external signals detected with a Hall element, etc., clear the TGCRA.FB bit to 0. In this case, the external signals indicating the magnetic pole position should be input to pins MTIOC0A, MTIOC0B, and MTIOC0C in MTU0 (make appropriate settings with the port mode registers (PMn) and Pmn port function control register (PFCm) of the GPIO ports). When an edge is detected at pin MTIOC0A, MTIOC0B, or MTIOC0C, the output on/off state is switched automatically.

When the TGCRA.FB bit is 1, the output on/off state is switched when the UF, VF, or WF bit in TGCRA is cleared to 0 or set to 1.

The driving waveforms are output from the 6-phase PWM output pins for complementary PWM mode.

With this 6-phase output, while the output is turned on, chopping output is available through complementary PWM mode output function by setting the N bit or P bit in TGCRA to 1. When the N bit or P bit is 0, the level output is selected.

The active level of the 6-phase output (on output level) can be set with the TOCR1A.OLSN and TOCR1A.OLSP bits regardless of the setting of the N and P bits.

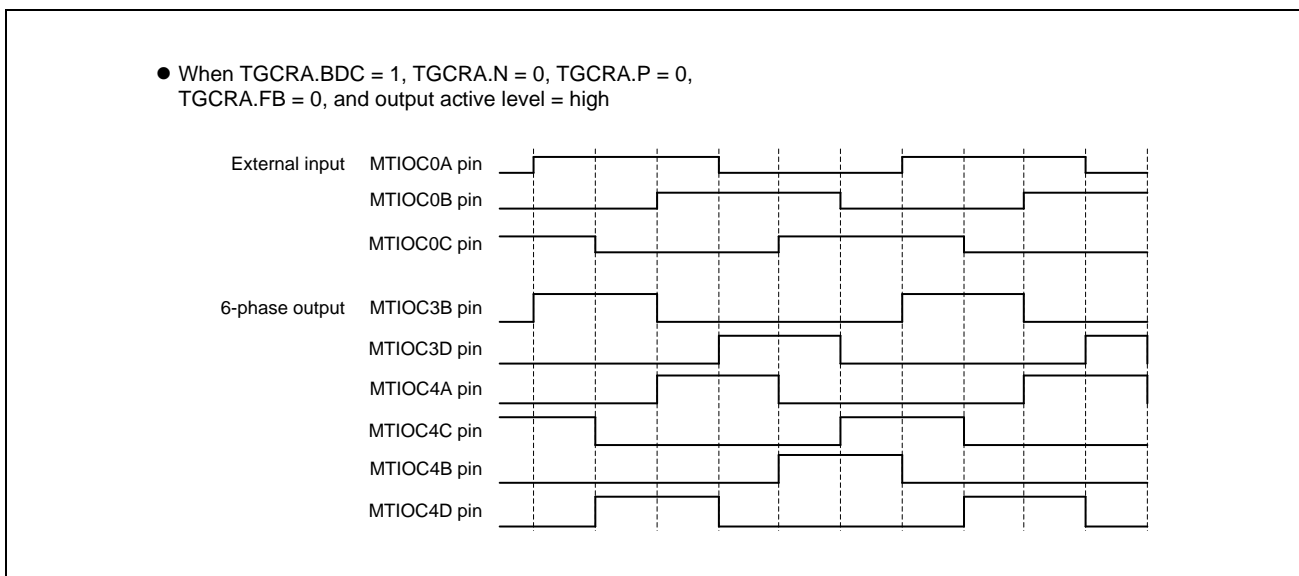

Figure 16.79 Example of Output Phase Switching by External Input (1)

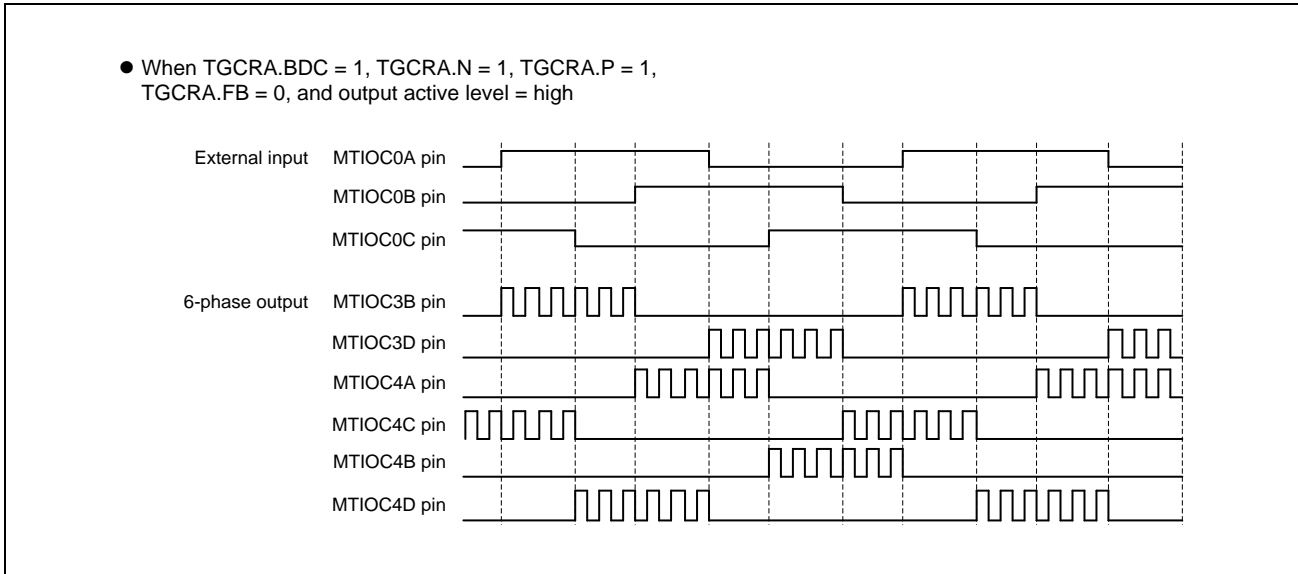

Figure 16.80 Example of Output Phase Switching by External Input (2)

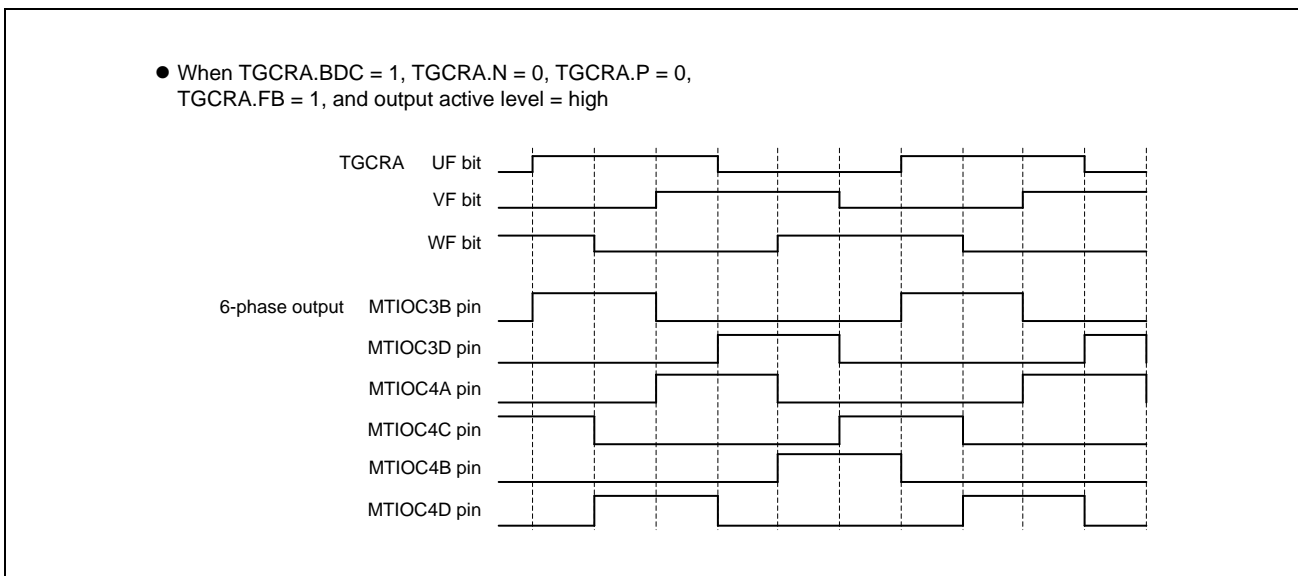

Figure 16.81 Example of Output Phase Switching through UF, VF, and WF Bit Settings (1)

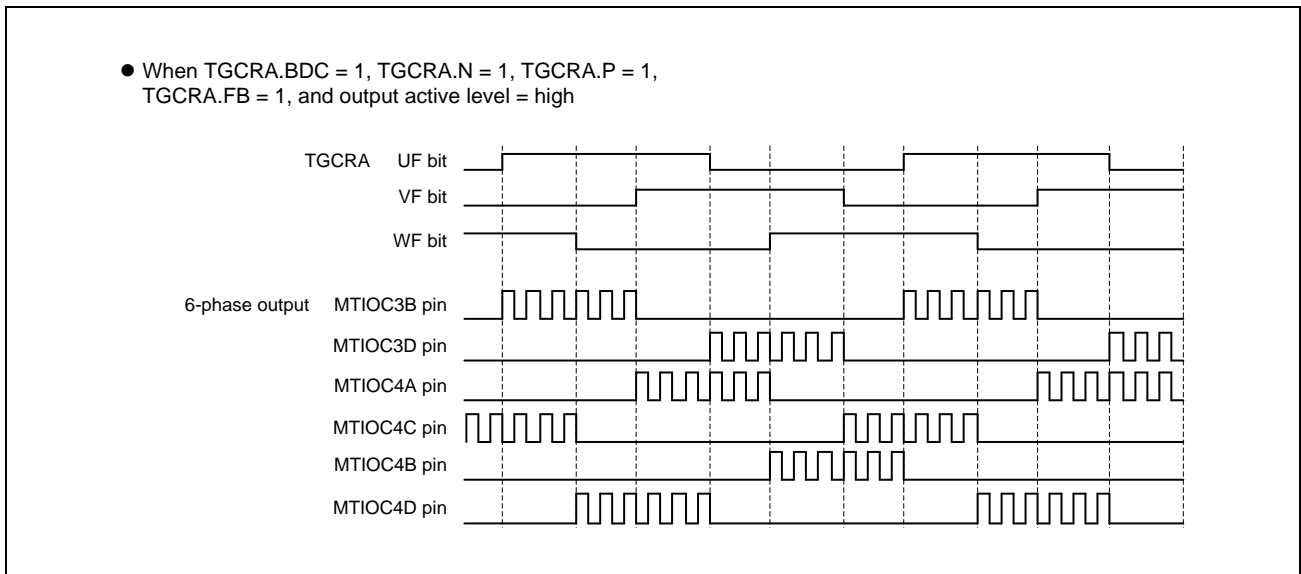

Figure 16.82 Example of Output Phase Switching through UF, VF, and WF Bit Settings (2)

(r) A/D Converter Start Request Setting

In complementary PWM mode, an A/D converter start request can be issued using MTU3.TGRA (MTU6.TGRA) compare match, MTU4.TCNT (MTU7.TCNT) underflow (trough), or compare match on a channel other than MTU3 and MTU4 (MTU6 and MTU7).

When start requests using MTU3.TGRA (MTU6.TGRA) compare match are specified, A/D conversion can be started at the crest of the MTU3.TCNT (MTU6.TCNT) count.

A/D converter start requests can be specified by setting the TIER.TTGE bit. To issue an A/D converter start request at an MTU4.TCNT (MTU7.TCNT) underflow (trough), set the MTU4.TIER.TTGE2 (MTU7.TIER.TTGE2) bit to 1.

(s) Double Buffer Function in Complementary PWM Mode

In complementary PWM mode 3 (transfer at the crest and trough), the PWM output setting resolution can be improved from ± 2 to ± 1 by setting the TMDR2A.DRS (TMDR2B.DRS) bit to 1.

When setting buffer registers A (TGRD in MTU3, TGRC and TGRD in MTU4, TGRD in MTU6, and TGRC and TGRD in MTU7), set also buffer registers B (TGRE in MTU3, TGRE and TGRF in MTU4, TGRE in MTU6, and TGRE and TGRF in MTU7) at the same time. Each buffer register B should be set to the buffer register A value or (buffer register A value - 1). For details of the setting procedure, refer to **Section 16.3.8(1), Example of Complementary PWM Mode Setting Procedure**.

NOTE

When a buffer register B is set to the buffer register A value, symmetric PWM waveforms are output. When a buffer register B is set to (buffer register A value - 1), asymmetric PWM waveforms are output.

Figure 16.83 shows an example of double buffer operation. Each register data is transferred as follows.

- After TGRD (buffer A) in MTU4 or MTU7 is written to, data is transferred from TGRD (buffer A) in MTU4 or MTU7 to Temp3A or Temp6A (temporary A) and from TGRF (buffer B) in MTU4 or MTU7 to Temp3B or Temp6B (temporary B).
- With timing (1) in the figure, data is transferred from Temp3A or Temp6A (temporary A) to TGRB (compare) in MTU4 or MTU7.
- With timing (2) in the figure, data is transferred from Temp3B or Temp6B (temporary B) to TGRB (compare) in MTU4 or MTU7.

In the crest interval (T_{b1} interval), the compare register and temporary register A are valid; in the trough interval (T_{b2} interval), the compare register and temporary register B are valid.

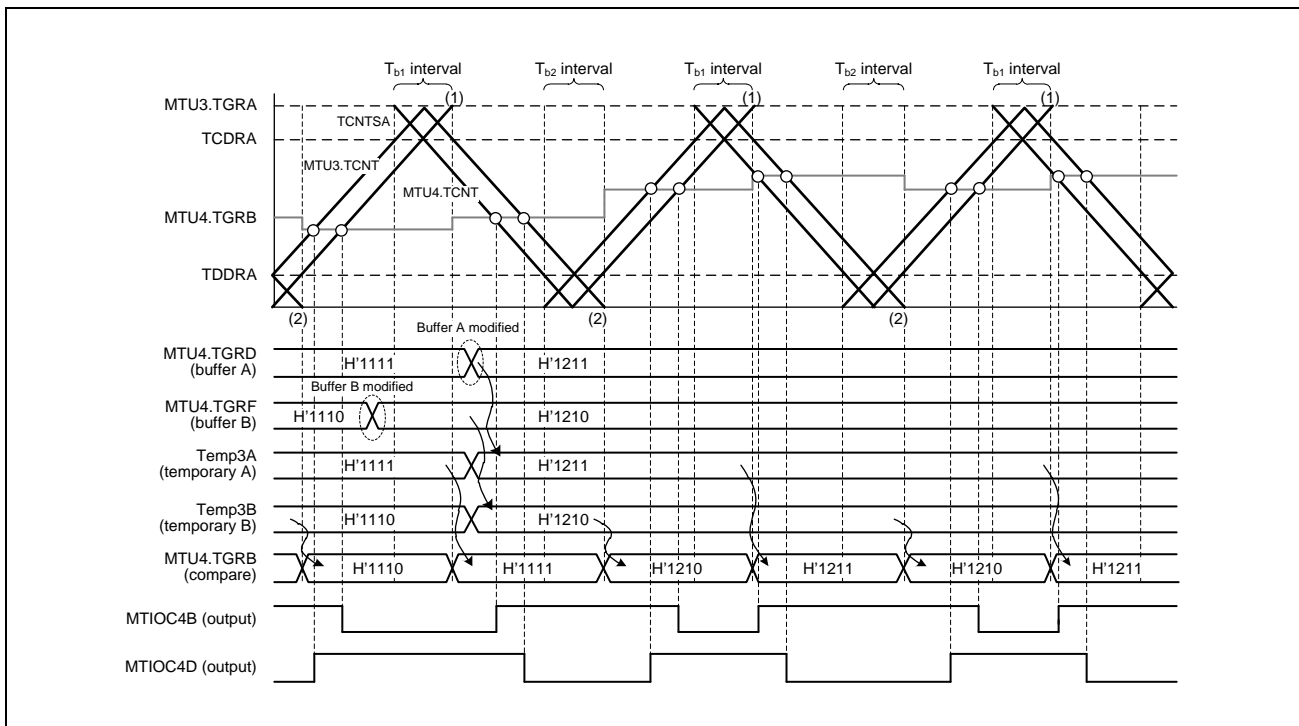

Figure 16.83 Example of Double Buffer Operation

Figure 16.84 shows an example when the buffer write value is smaller than the TDDRA (TDDRB) value, and **Figure 16.85** shows an example when the write value is greater than TCDRA (TCDRB).

In the crest interval, the output is controlled according to the compare match with the compare register or temporary register A; in the trough interval, the output is controlled according to the compare match with the compare register or temporary register B.

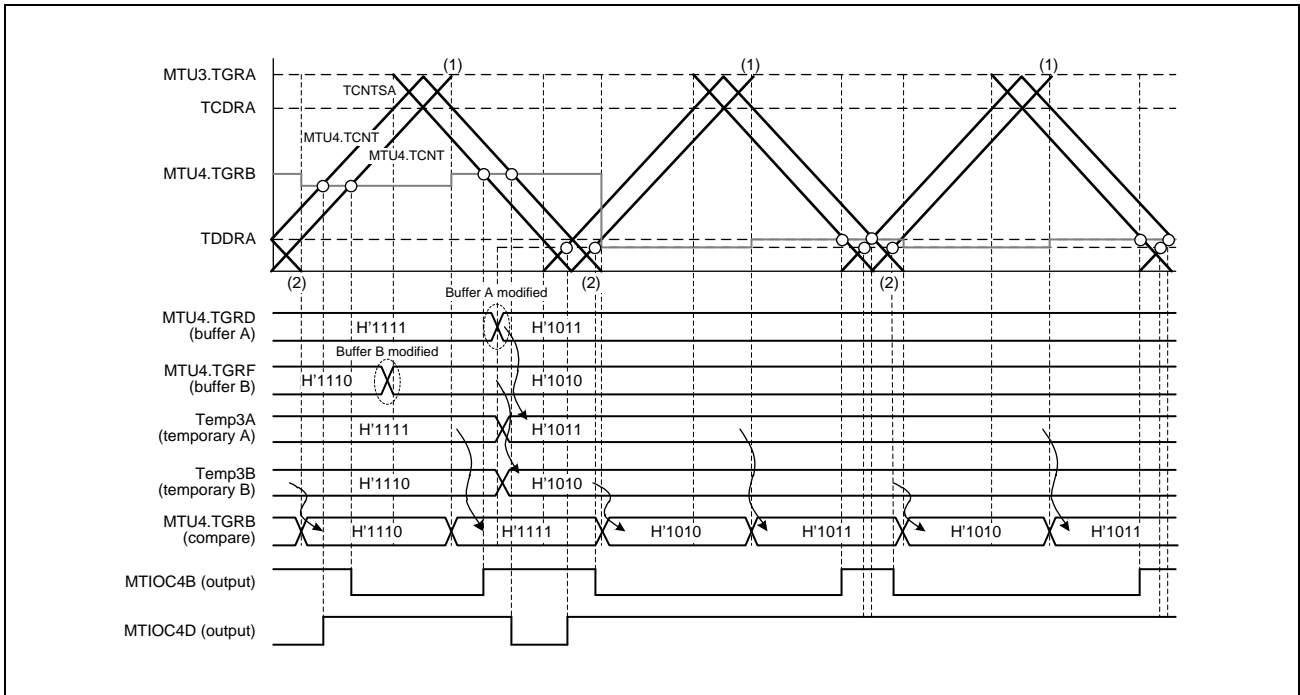

Figure 16.84 Example of Double Buffer Operation (Buffer Write Value is Smaller than TDDRA)

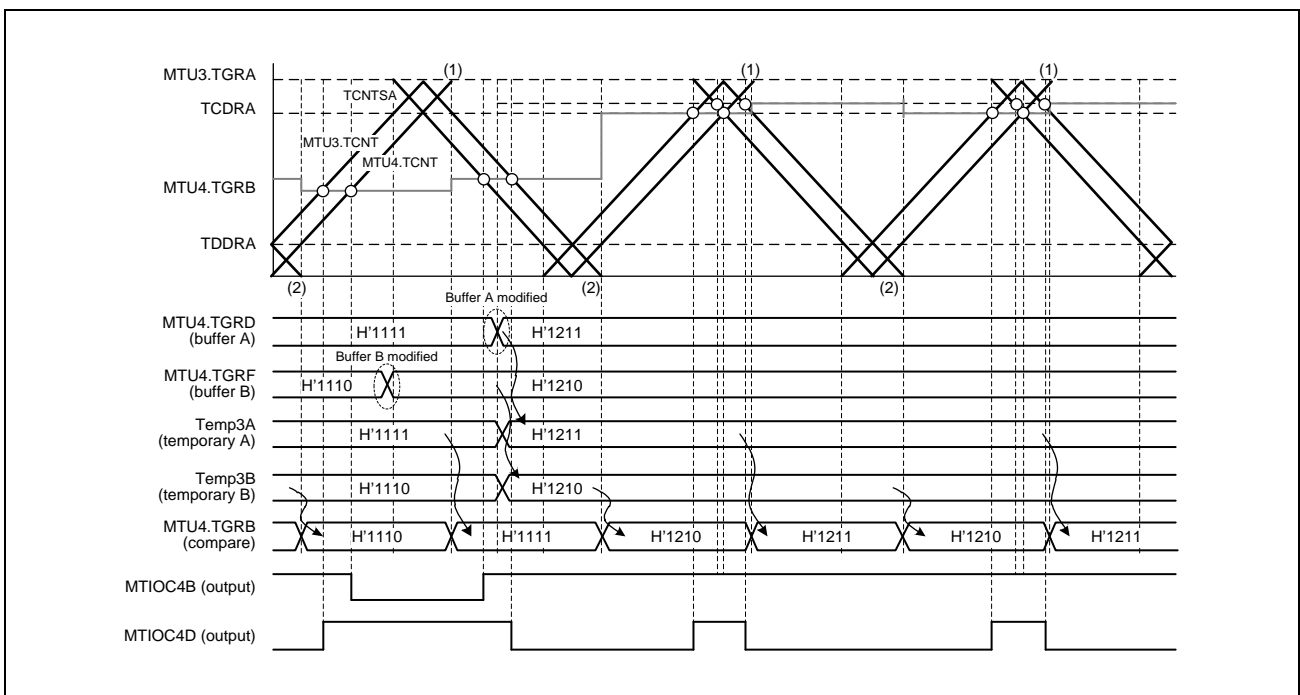

Figure 16.85 Example of Double Buffer Operation (Buffer Write Value is Greater than TCDRA)

(3) Interrupt Skipping Function 1 in Complementary PWM Mode

Interrupts TGIA3 (TGIA6) (at the crest) and TCIV4 (TCIV7) (at the trough) in MTU3 and MTU4 (MTU6 and MTU7) can be skipped up to seven times by making settings in the TITCR1A (TITCR1B) register.

Transfers from a buffer register to a temporary register or a compare register can be skipped in coordination with interrupt skipping by making settings in the TBTERA (TBTERB) register. For the linkage with buffer registers, refer to description (c), Buffer Transfer Control Linked with Interrupt Skipping, below.

A/D converter start requests generated by the A/D converter start request delaying function can also be skipped in coordination with interrupt skipping by making settings in the MTU4.TADCR (MTU7.TADCR) register. For the linkage with the A/D converter start request delaying function, refer to **Section 16.3.9, A/D Converter Start Request Delaying Function**.

The TITCR1A (TITCR1B) register should be set while interrupt skipping function 1 is selected by setting the TITM bit in the timer interrupt skipping mode register (TITMRA or TITMRB) to 0, TGIA3 (TGIA6) interrupt requests are disabled by setting the MTU3.TIER (MTU6.TIER) register, TCIV4 (TCIV7) interrupt requests are disabled by setting the MTU4.TIER (MTU7.TIER) register, and a compare match is not generated. Before changing the skipping count, be sure to clear the T3AEN (T6AEN) and T4VEN (T7VEN) bits to 0 to clear the skipping counter.

(a) Example of Interrupt Skipping Function 1 Setting Procedure

Figure 16.86 shows an example of the interrupt skipping function 1 setting procedure. **Figure 16.87** shows the periods during which interrupt skipping count can be changed.

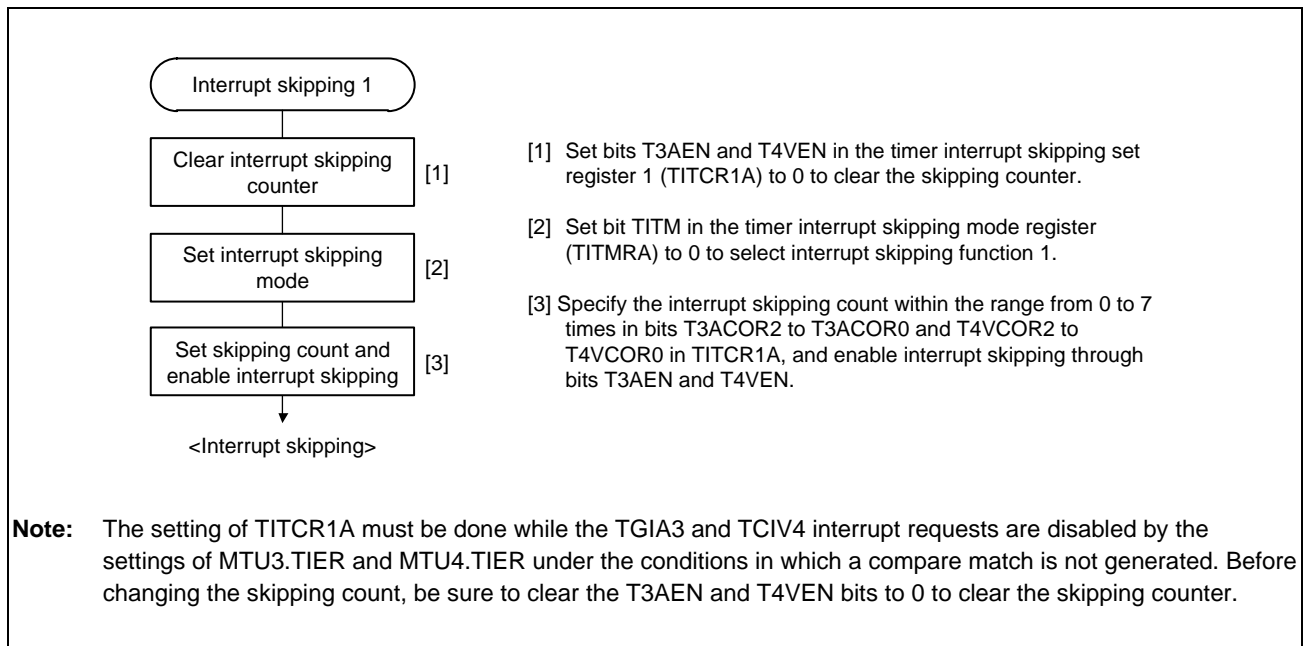

Figure 16.86 Example of Interrupt Skipping Function 1 Setting Procedure

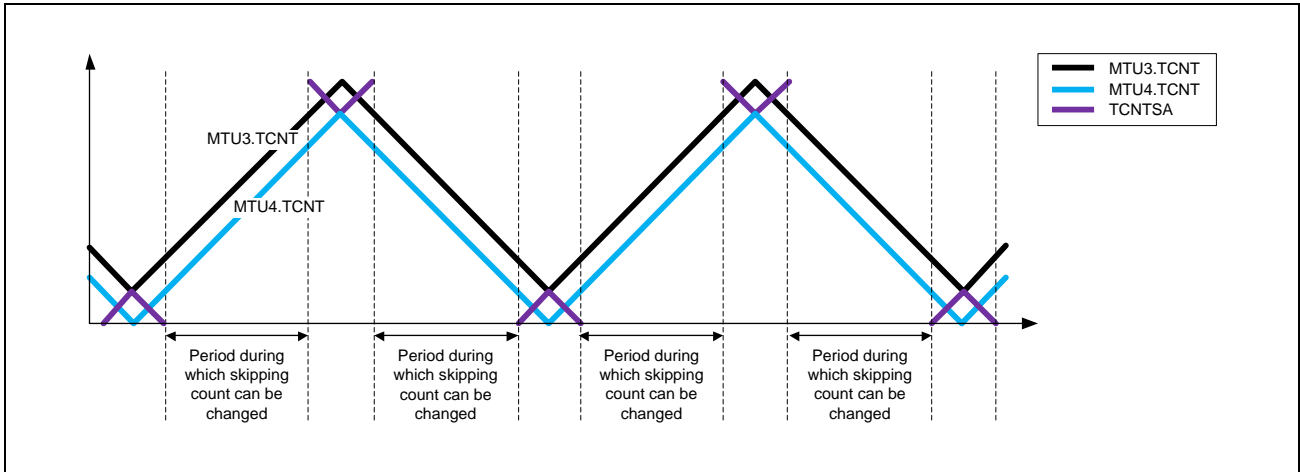

Figure 16.87 Periods during which Interrupt Skipping Count can be Changed

(b) Example of Interrupt Skipping Function 1

Figure 16.88 shows an example of TGIA3 (TGIA6) interrupt skipping in which the interrupt skipping count is set to three by the T3ACOR (T6ACOR) bits and the T3AEN (T6AEN) bit is set to 1 in the TITCR1A (TITCR1B) register.

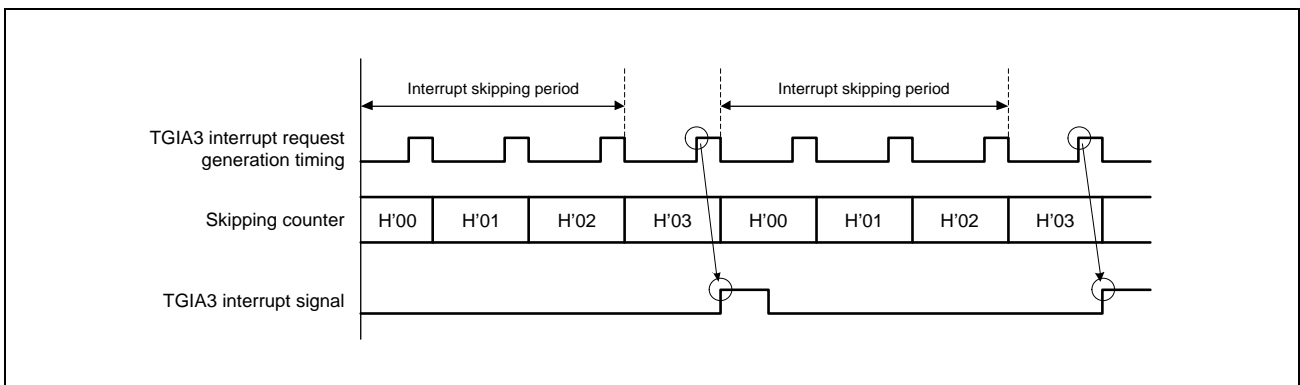

Figure 16.88 Example of Interrupt Skipping Function 1

(c) Buffer Transfer Control Linked with Interrupt Skipping

In complementary PWM mode, whether to transfer data from a buffer register to a temporary register and whether to link the transfer with interrupt skipping can be specified with the BTE[1:0] bits in the TBTERA (TBTERB) register.

Figure 16.89 shows an example of operation when buffer transfer is disabled (BTE[1:0] = 01b). While this setting is valid, data is not transferred from the buffer register to the temporary register.

Figure 16.90 shows an example of operation when buffer transfer is linked with interrupt skipping (BTE[1:0] = 10b). While this setting is valid, data is not transferred from the buffer register outside the buffer transfer-enabled period.

Note that the buffer transfer-enabled period differs depending on whether only the T3AEN (T6AEN) bit in the TITCR1A (TITCR1B) register is set to 1, only the T4VEN (T7VEN) bit in the TITCR1A (TITCR1B) register is set to 1, or both the T3AEN and T4VEN (T6AEN and T7VEN) bits are set to 1. **Figure 16.91** shows the relationship between the T3AEN (T6AEN) and T4VEN (T7VEN) bit settings in TITCR1A (TITCR1B) and buffer transfer-enabled period.

NOTE

This function must be used in combination with interrupt skipping function 1.

When interrupt skipping is disabled (the T3AEN and T4VEN (T6AEN and T7VEN) bits in the timer interrupt skipping set register 1 (TITCR1A or TITCR1B) are cleared to 0 or the skipping count set bits (T3ACOR and T4VCOR (T6ACOR and T7VCOR)) in TITCR1A (TITCR1B) are cleared to 0), make sure that buffer transfer is not linked with interrupt skipping (clear the BTE1 bit in TBTERA or TBTERB to 0).

If buffer transfer is linked with interrupt skipping while interrupt skipping is disabled, buffer transfer is never performed.

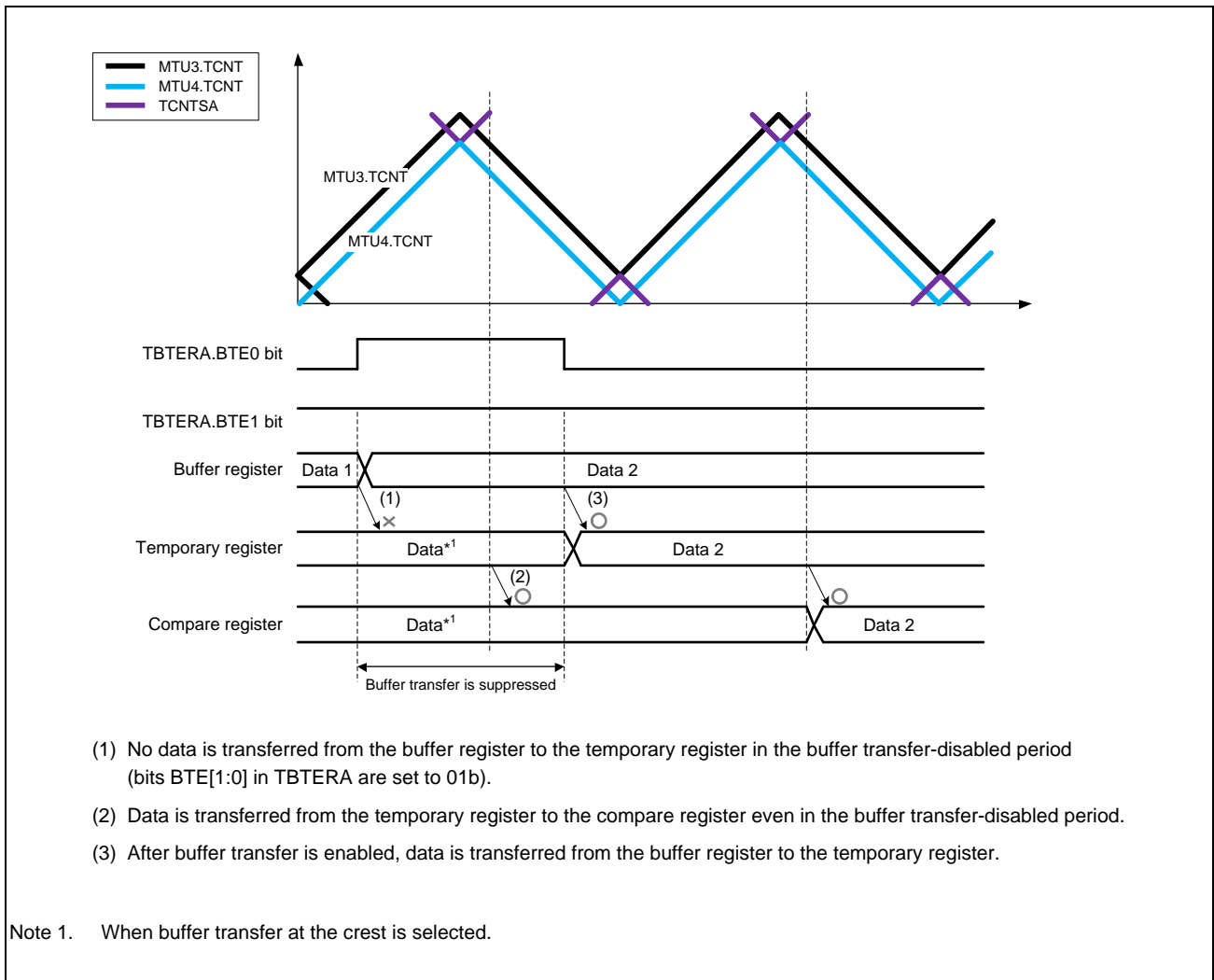

Figure 16.89 Example of Operation When Buffer Transfer is Disabled (BTE[1:0] = 01b)

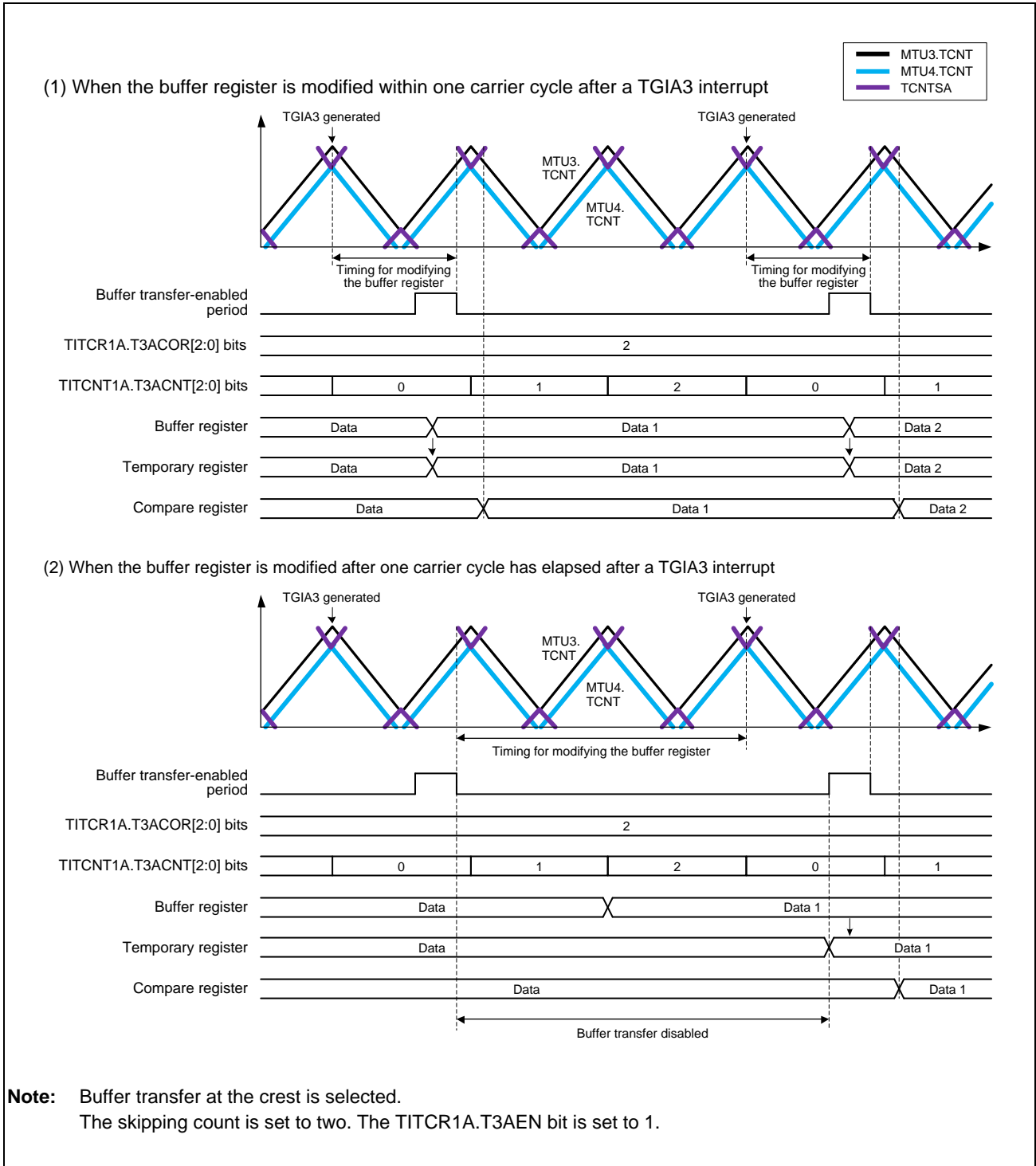

Figure 16.90 Example of Operation When Buffer Transfer is Linked with Interrupt Skipping (BTE[1:0] = 10b)

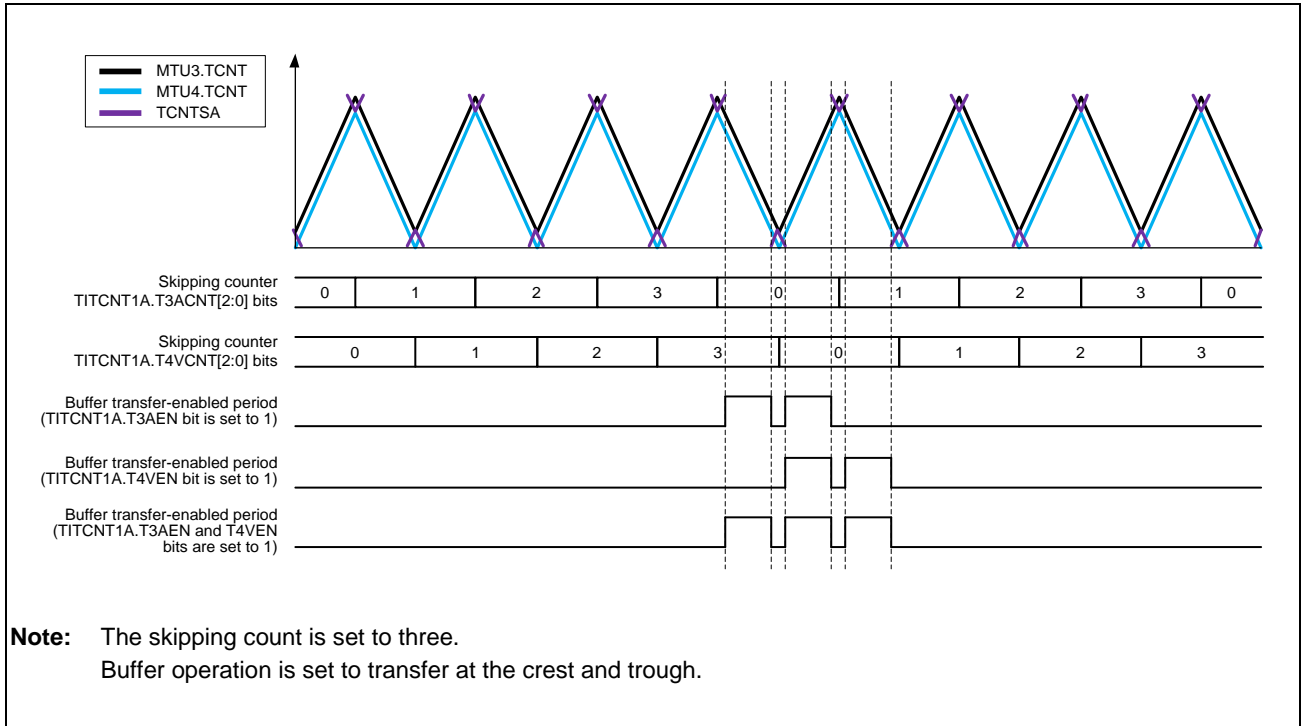

Figure 16.91 Relationship between Bits T3AEN and T4VEN in TITCR1A and Buffer Transfer-Enabled Period

(4) Complementary PWM Mode Output Protection Functions

The following output protection functions are provided for complementary PWM mode.

(a) Register and Counter Miswrite Prevention Function

Access from the CPU to the mode registers, control registers, compare registers, and counters can be enabled or disabled by setting the RWE bit in the TRWERA (TRWERB) register. The applicable registers are some of the registers in MTU3, MTU4, MTU6, and MTU7 shown below:

MTU3.TCR, MTU4.TCR, MTU3.TCR2, MTU4.TCR2, MTU3.TMDR1, MTU4.TMDR1, MTU3.TIORH, MTU4.TIORH, MTU3.TIORL, MTU4.TIORL, MTU3.TIER, MTU4.TIER, MTU3.TCNT, MTU4.TCNT, MTU3.TGRA, MTU4.TGRA, MTU3.TGRB, MTU4.TGRB, MTU.TOERA, MTU.TOCR1A, MTU.TOCR2A, MTU.TGCRA, MTU.TCDRA, MTU.TDDRA MTU6.TCR, MTU7.TCR, MTU6.TCR2, MTU7.TCR2, MTU6.TMDR1, MTU7.TMDR1, MTU6.TIORH, MTU7.TIORH, MTU6.TIORL, MTU7.TIORL, MTU6.TIER, MTU7.TIER, MTU6.TCNT, MTU7.TCNT, MTU6.TGRA, MTU7.TGRA, MTU6.TGRB, MTU7.TGRB, MTU.TOERB, MTU.TOCR1B, MTU.TOCR2B, MTU.TCDRB, and MTU.TDDRB

47 registers in total

This function can disable CPU access to the mode registers, control registers, and counters to prevent miswriting due to CPU runaway. In the access-disabled state, the applicable registers are read as undefined and writing to these registers is ignored.

(b) Halting of PWM Output by External Signal

The PWM output pins of MTU0, MTU3, MTU4, MTU6, and MTU7 can be set to the high-impedance state automatically.

See **Section 17, Port Output Enable 3 (POE3)**, for details.

16.3.9 A/D Converter Start Request Delaying Function

A/D converter start requests can be issued in MTU4 or MTU7 by making settings in the timer A/D converter start request control register (MTU4.TADCR or MTU7.TADCR), timer A/D converter start request cycle set registers (MTU4.TADCORA and MTU4.TADCORB, or MTU7.TADCORA and MTU7.TADCORB), and timer A/D converter start request cycle set buffer registers (MTU4.TADCOBRA and MTU4.TADCOBRB, or MTU7.TADCOBRA and MTU7.TADCOBRB).

The A/D converter start request delaying function compares MTU4.TCNT with MTU4.TADCORA or MTU4.TADCORB (MTU7.TCNT with MTU7.TADCORA or MTU7.TADCORB), and when their values match, the function issues a respective A/D converter start request (TRG4AN or TRG4BN (TRG7AN or TRG7BN)).

A/D converter start requests (TRG4AN and TRG4BN (TRG7AN and TRG7BN)) can be skipped in coordination with interrupt skipping by making settings in the ITA3AE, ITA4VE, ITB3AE, and ITB4VE bits in the TADCR register in MTU4 (the ITA6AE, ITA7VE, ITB6AE, and ITB7VE bits in the TADCR register in MTU7).

(1) Example of Procedure for Specifying A/D Converter Start Request Delaying Function

Figure 16.92 shows an example of procedure for specifying the A/D converter start request delaying function.

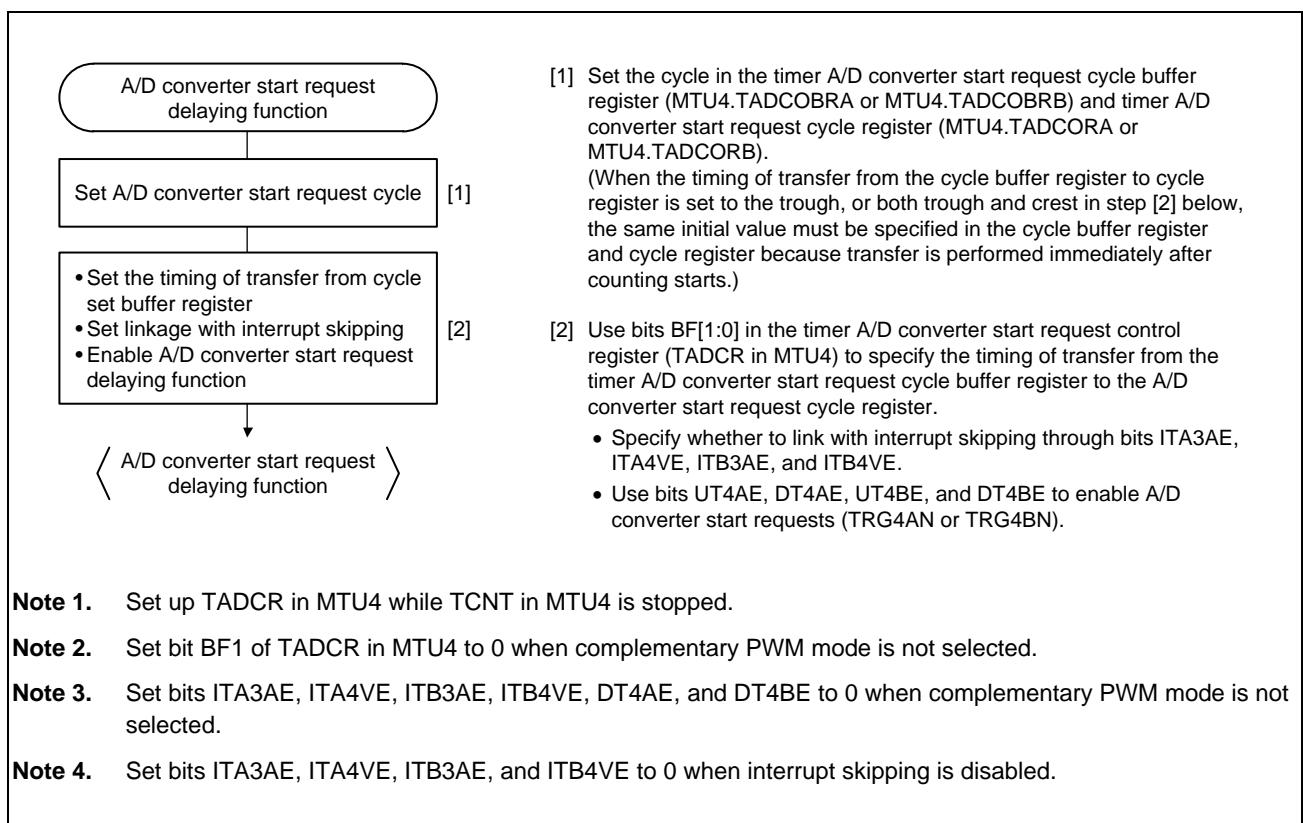

Figure 16.92 Example of Procedure for Specifying A/D Converter Start Request Delaying Function (MTU3 and MTU4)

(2) Basic Example of A/D Converter Start Request Delaying Function Operation

Figure 16.93 shows a basic example of A/D converter start request signal (TRG4AN (TRG7AN)) operation when the trough of MTU4.TCNT (MTU7.TCNT) is specified for the buffer transfer timing and an A/D converter start request signal is output during MTU4.TCNT (MTU7.TCNT) down-counting.

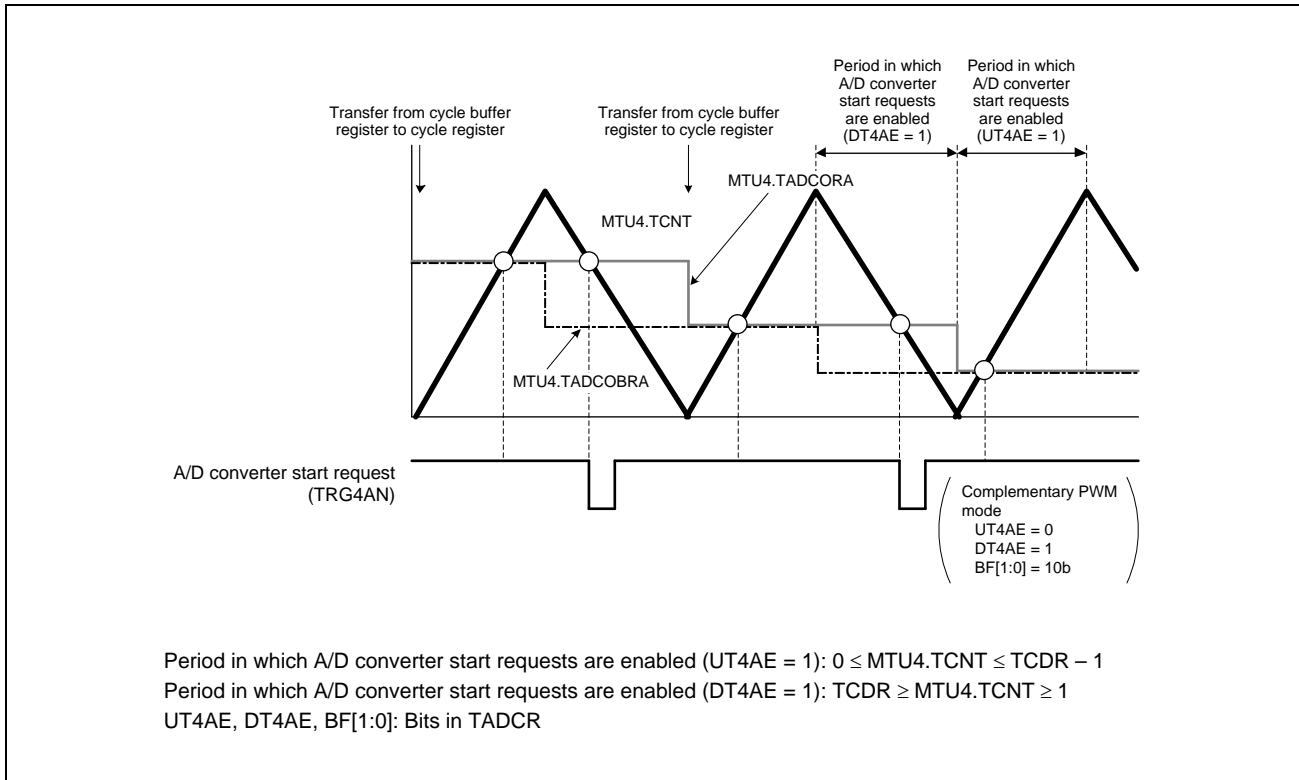

Figure 16.93 Basic Example of A/D Converter Start Request Signal (TRG4AN) Operation

(3) Period in which A/D Converter Start Requests are Enabled

An A/D converter start request (TRG4AN or TRG4BN) can be issued when the TCNT counter value in MTU4 (MTU7) matches the value of the corresponding cycle set register (TADCORA or TADCORB) in MTU4 (MTU7) within the period specified by the UT4AE or UT4BE (UT7AE or UT7BE) bit of TADCR in MTU4 (MTU7).

When the UT4AE or UT4BE (UT7AE or UT7BE) bit is set to 1 in complementary PWM mode, issuing of AD converter start requests is enabled for the period of TCNT up-counting ($0 \leq \text{TCNT} \leq \text{TCDR} - 1$) in MTU4 (MTU7). When the DT4AE or DT4BE (DT7AE or DT7BE) bit is set to 1, issuing of AD converter start requests is enabled for the period of TCNT down-counting ($\text{TCDR} \geq \text{TCNT} \geq 1$) in MTU4 (MTU7) (**Figure 16.93**).

(4) Buffer Transfer

The data in the timer A/D converter start request cycle set registers (MTU4.TADCORA and MTU4.TADCORB, or MTU7.TADCORA and MTU7.TADCORB) is updated by writing data to the timer A/D converter start request cycle set buffer registers (MTU4.TADCOBRA and MTU4.TADCOBRB, or MTU7.TADCOBRA and MTU7.TADCOBRB). Data is transferred from the buffer registers to the respective cycle set registers at the timing selected with the BF[1:0] bits in the MTU4.TADCR (MTU7.TADCR) register.

In complementary PWM mode, data is also transferred from the timer A/D converter start request cycle set buffer registers to the timer A/D converter start request cycle set registers when MTU4.TGRD (MTU7.TGRD) register is updated.

When using buffer transfer in complementary PWM mode, pay attention to the buffer transfer timing. For details, refer to **Section 16.6.26, Notes on A/D Converter Start Request Delaying Function in Complementary PWM Mode**. When complementary PWM mode is not selected, be sure to clear the BF1 bit of the TADCR register in MTU4 or MTU7.

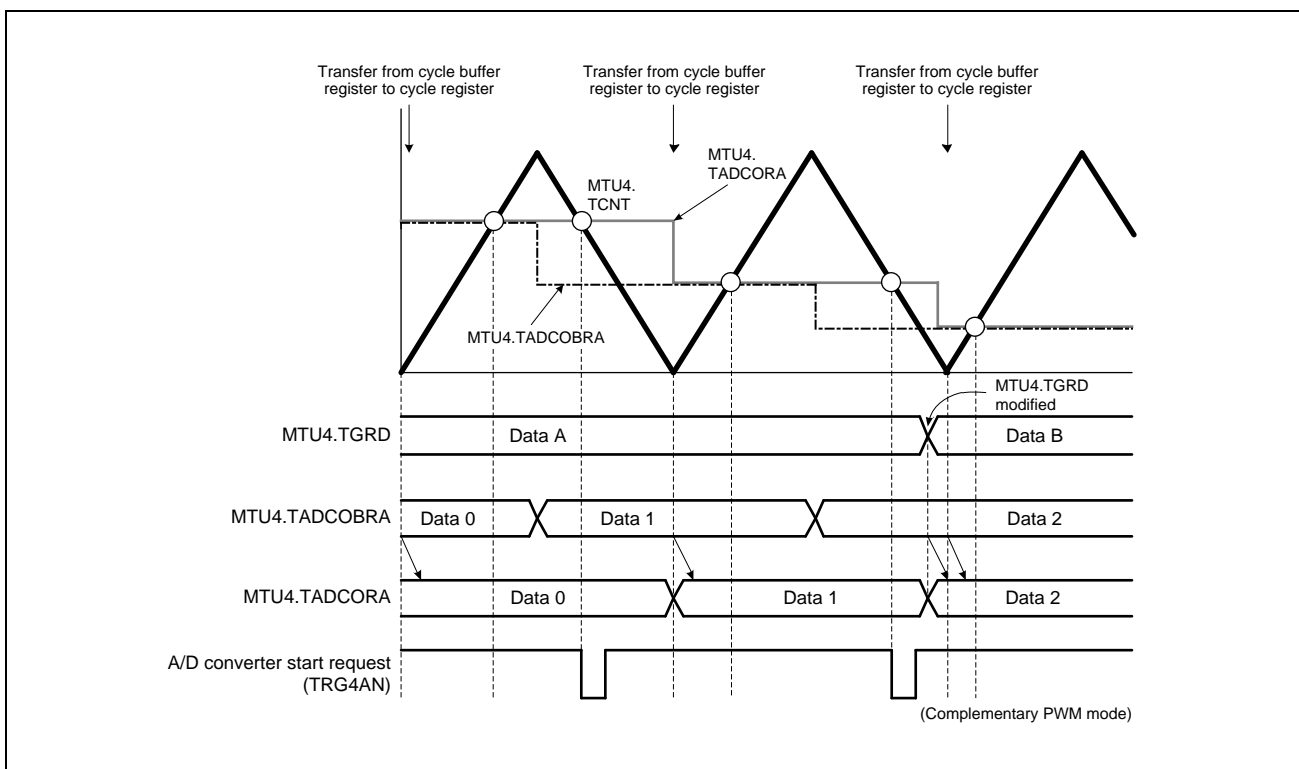

Figure 16.94 Example of A/D Converter Start Request Signal (TRG4AN) and Buffer Transfer Operation

(5) A/D Converter Start Request Delaying Function Linked with Interrupt Skipping Function 1

In complementary PWM mode, A/D converter start requests (TRG4AN and TRG4BN (TRG7AN and TRG7BN)) can be issued in coordination with interrupt skipping 1 by setting the ITA3AE, ITA4VE, ITB3AE, and ITB4VE (ITA6AE, ITA7VE, ITB6AE, and ITB7VE) bits of the TADCR register in MTU4 (MTU7).

Figure 16.95 shows an example of A/D converter start request signal (TRG4AN (TRG7AN)) operation when TRG4AN (TRG7AN) output is enabled during MTU4.TCNT (MTU7.TCNT) up-counting and down-counting and A/D converter start requests are linked with interrupt skipping 1.

Figure 16.96 shows another example of A/D converter start request signal (TRG4AN (TRG7AN)) operation when TRG4AN (TRG7AN) output is enabled during MTU4.TCNT (MTU7.TCNT) up-counting and A/D converter start requests are linked with interrupt skipping 1.

When complementary PWM mode is not selected, A/D converter start request delaying function cannot be used in coordination with interrupt skipping 1; clear the ITA3AE, ITA4VE, ITB3AE, and ITB4VE (ITA6AE, ITA7VE, ITB6AE, and ITB7VE) bits of the TADCR register to 0 in MTU4 (MTU7).

NOTE

This function should be used in combination with interrupt skipping 1.

When interrupt skipping is disabled (the T3AEN and T4VEN (T6AEN and T7VEN) bits in the timer interrupt skipping set register (TITCR1A (TITCR1B)) are cleared to 0 or the skipping count set bits (T3ACOR and T4VCOR (T6ACOR and T7VCOR)) in TITCR1A (TITCR1B) are cleared to 0), make sure that A/D converter start requests are not linked with interrupt skipping 1 (clear the ITA3AE, ITA4VE, ITB3AE, and ITB4VE (ITA6AE, ITA7VE, ITB6AE, and ITB7VE) bits in the timer A/D converter start request control register (MTU4.TADCR (MTU7.TADCR)) to 0).

When this function is used, MTU4.TADCORA and MTU4.TADCORB (MTU7.TADCORA and MTU7.TADCORB) should be set with the value ranging H'0002 to the value set in TCDRA minus 2 (value set in TCDRB minus 2).

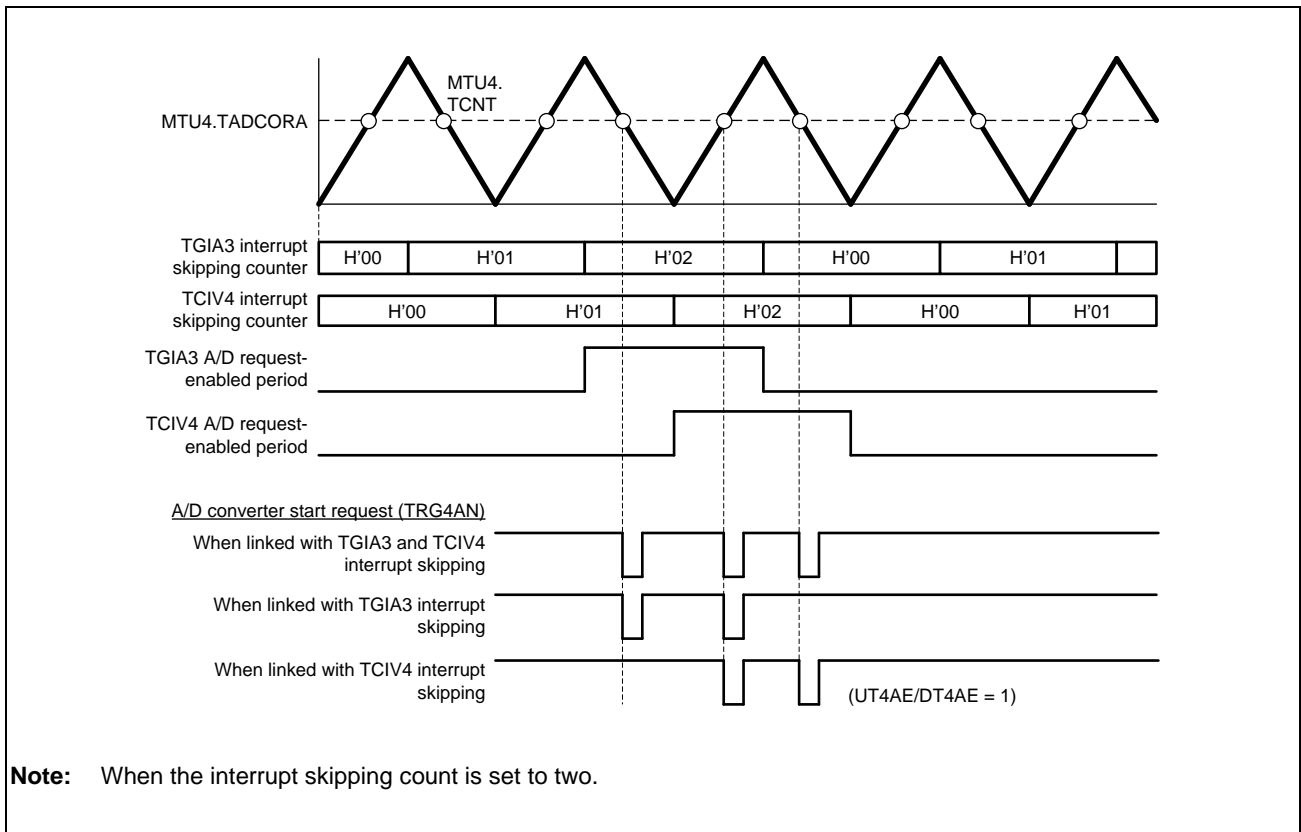

Figure 16.95 Example of A/D Converter Start Request Signal (TRG4AN) Operation Linked with Interrupt Skipping Function 1 (UT4AE and DT4AE = 1)

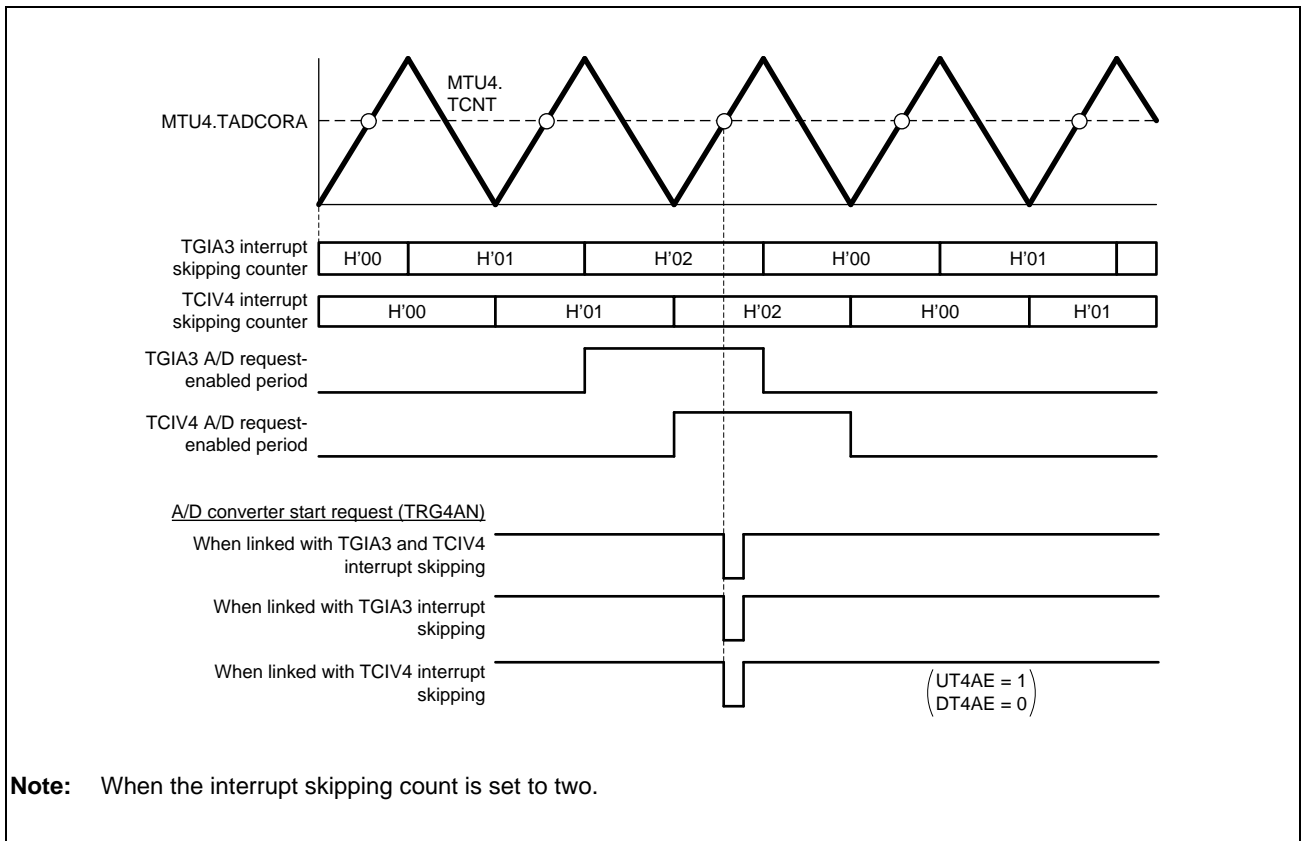

Figure 16.96 Example of A/D Converter Start Request Signal (TRG4AN) Operation Linked with Interrupt Skipping Function 1 (UT4AE = 1, DT4AE = 0)

(6) A/D Converter Start Request Delaying Function Linked with Interrupt Skipping Function 2

By setting the TITM bit to 1 in the TITMRA (TITMRB) register, the counter starts down-counting from the value (0 to 7) set in the TRG4COR[2:0] (TRG7COR[2:0]) bits in TITCR2A (TITCR2B) register every time an A/D converter start trigger (TRG4AN or TRG4BN (TRG7AN or TRG7BN)) is generated. When the counter value reaches 0 and is reloaded, the TRG4AN and TRG4BN (TRG7AN and TRG7BN) interrupts become valid and an A/D converter start request signal (TRG4ABN (TRG7ABN)) is output.

This function is valid only when the A/D converter request delaying function is enabled.

(a) Example of Procedure for Setting Interrupt Skipping Function 2

Figure 16.97 shows an example of procedure for setting interrupt skipping function 2.

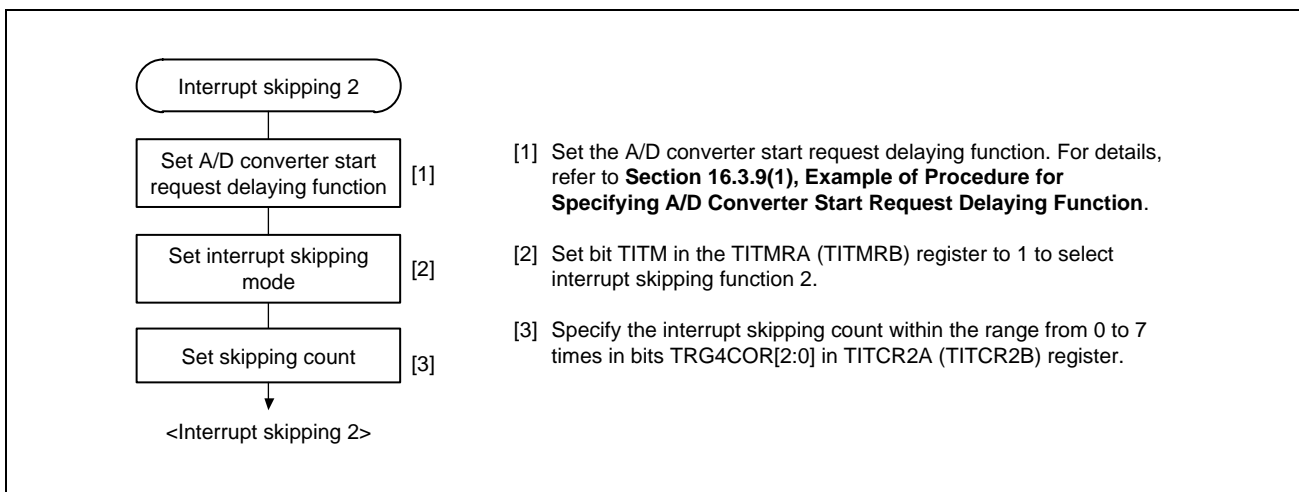

Figure 16.97 Example of Procedure for Setting Interrupt Skipping Function 2

(b) Example of Interrupt Skipping Function 2 Operation

Figure 16.98 shows an example of interrupt skipping 2 operation.

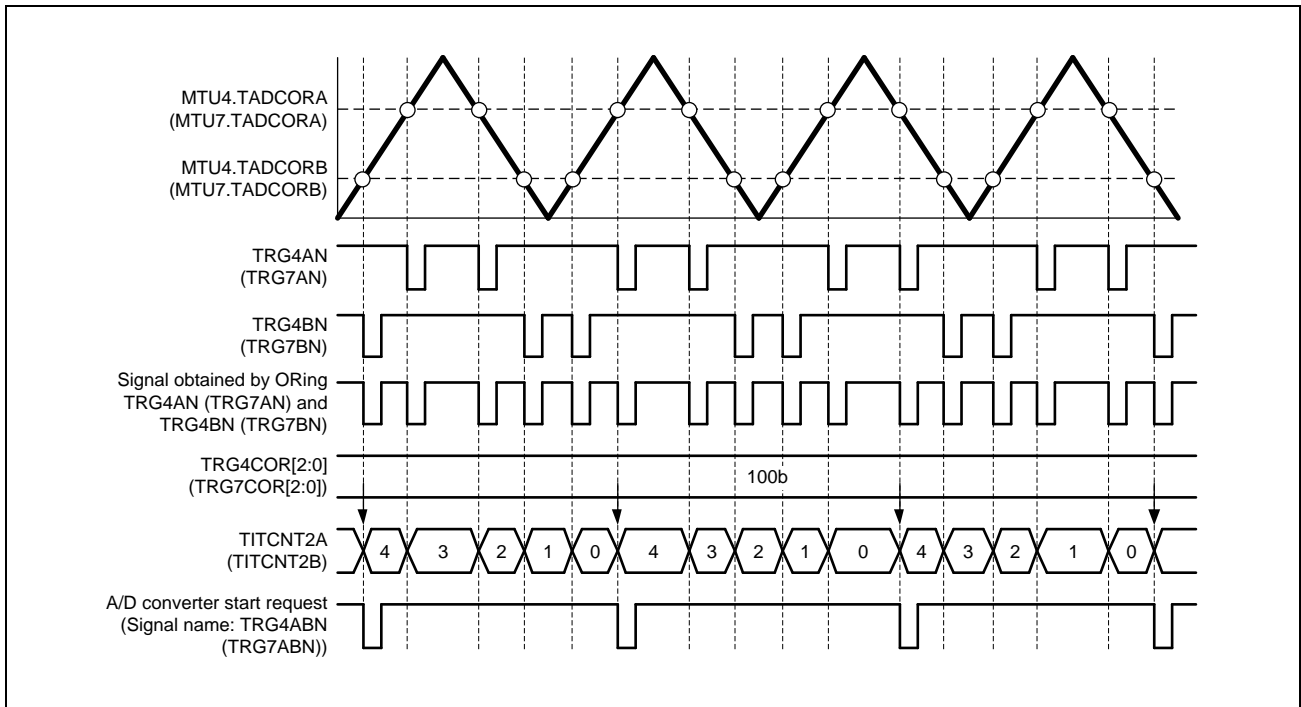

Figure 16.98 Example of Interrupt Skipping 2 Operation (Skipping Count is Set to Four)

16.3.10 Synchronous Operation of MTU0 to MTU4, MTU6, and MTU7

(1) Synchronous Counter Start for MTU0 to MTU4, MTU6, and MTU7

The counters in MTU0 to MTU4, MTU6, and MTU7 can be started synchronously by making the TCSYSTR settings.

(a) Example of Procedure for Setting Synchronous Counter Start for MTU0 to MTU4, MTU6, and MTU7

Figure 16.99 shows an example of the procedure for specifying synchronous counter start in MTU0 to MTU4, MTU6, and MTU7.

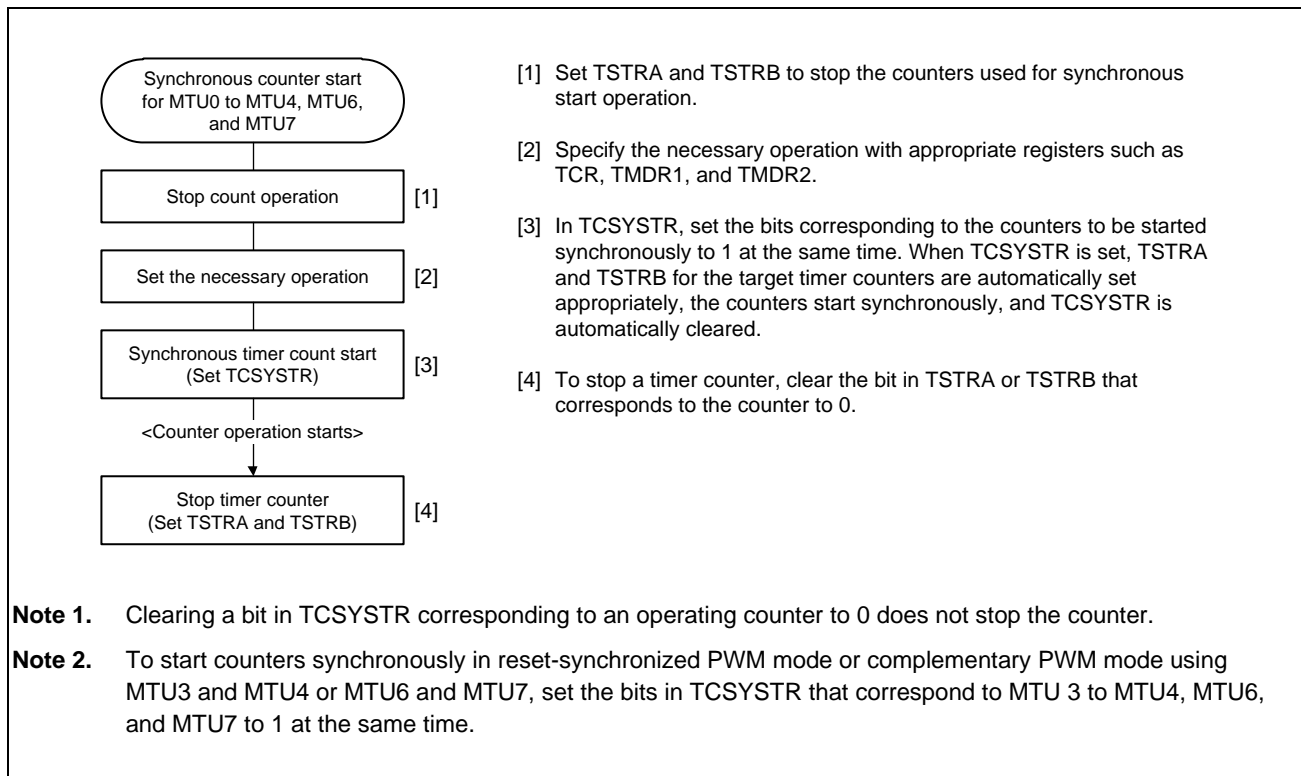

Figure 16.99 Example of Procedure for Specifying Synchronous Counter Start in MTU0 to MTU4, MTU6, and MTU7

(b) Examples of Synchronous Counter Start Operation

Figure 16.100 shows an example of the synchronous counter start operation in MTU0 to MTU4, MTU6, and MTU7.

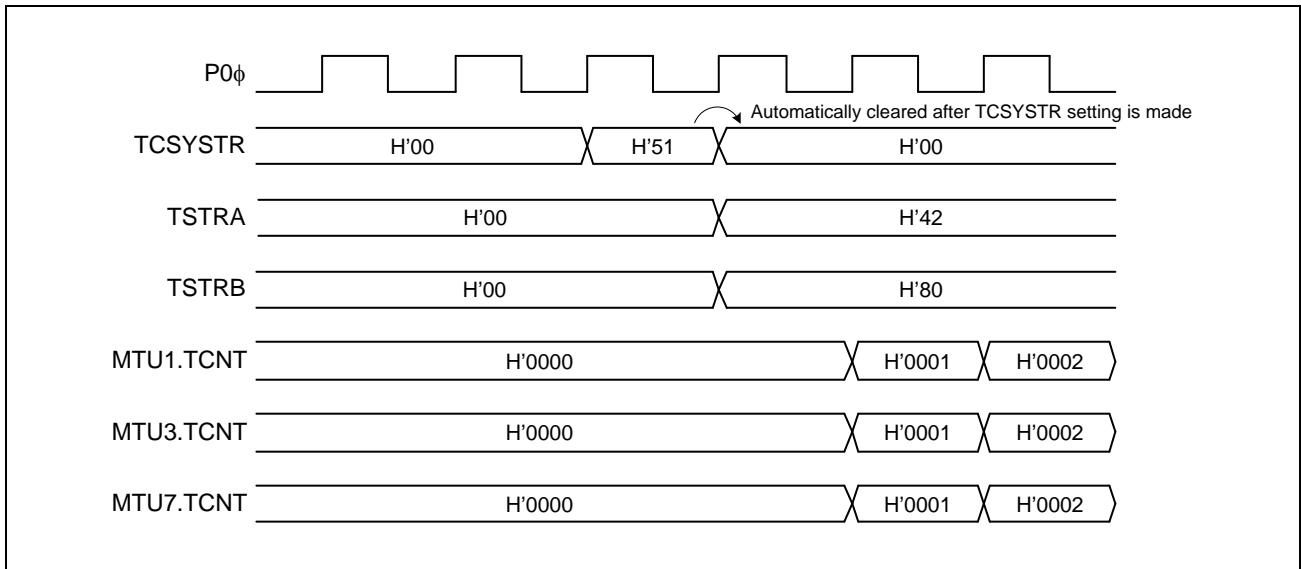

Figure 16.100 Example of Synchronous Counter Start Operation in MTU0 to MTU4, MTU6, and MTU7

(2) Synchronous Counter Clearing for MTU6 and MTU7

The counters in MTU6 and MTU7 can be cleared by the TGI_{mn} interrupt generation timing (m = A to D; n = 0 to 2) through the TSYCR setting.

(a) Example of Procedure for Specifying Synchronous Counter Clearing for MTU6 and MTU7

Figure 16.101 shows an example of the procedure for specifying synchronous counter clearing in MTU6 and MTU7 by using the interrupt generation timing.

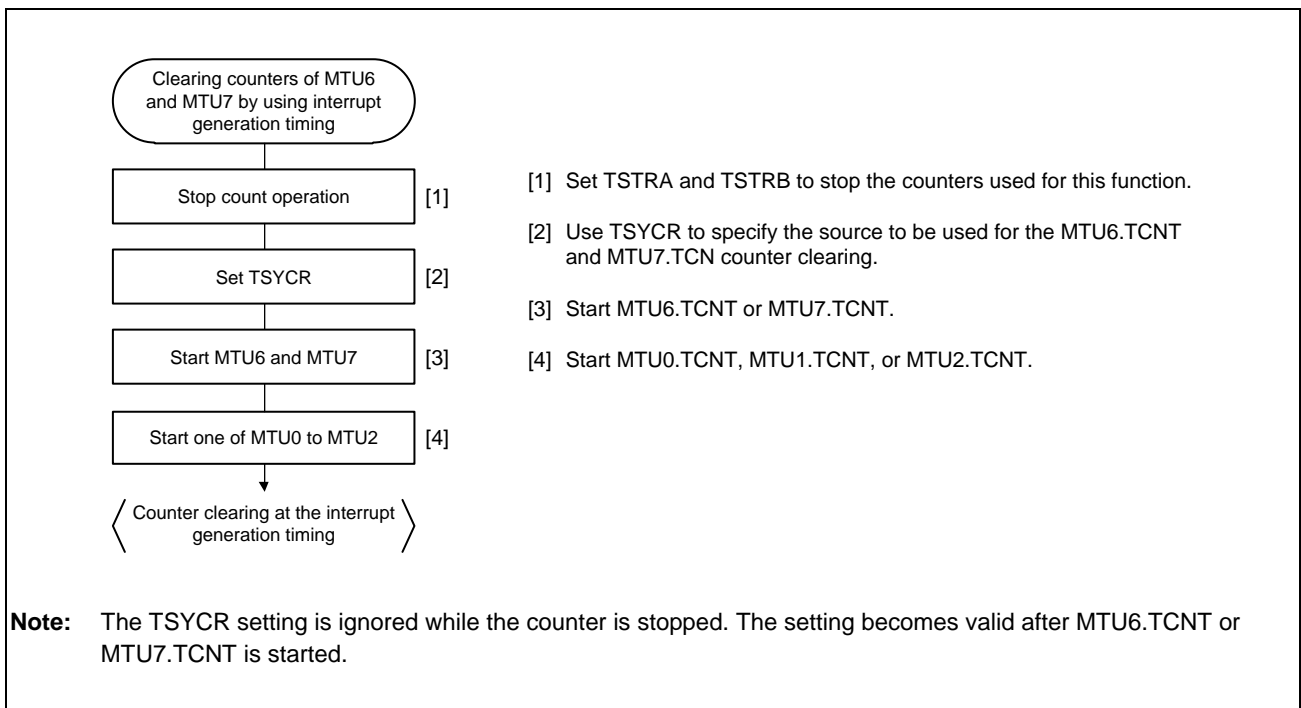

Figure 16.101 Example of Procedure for Specifying Synchronous Counter Clearing in MTU6 and MTU7

(b) Examples of Synchronous Counter Clearing in MTU6 and MTU7

Figure 16.102 and Figure 16.103 show examples of synchronous counter clearing in MTU6 and MTU7 by using the interrupt generation timing.

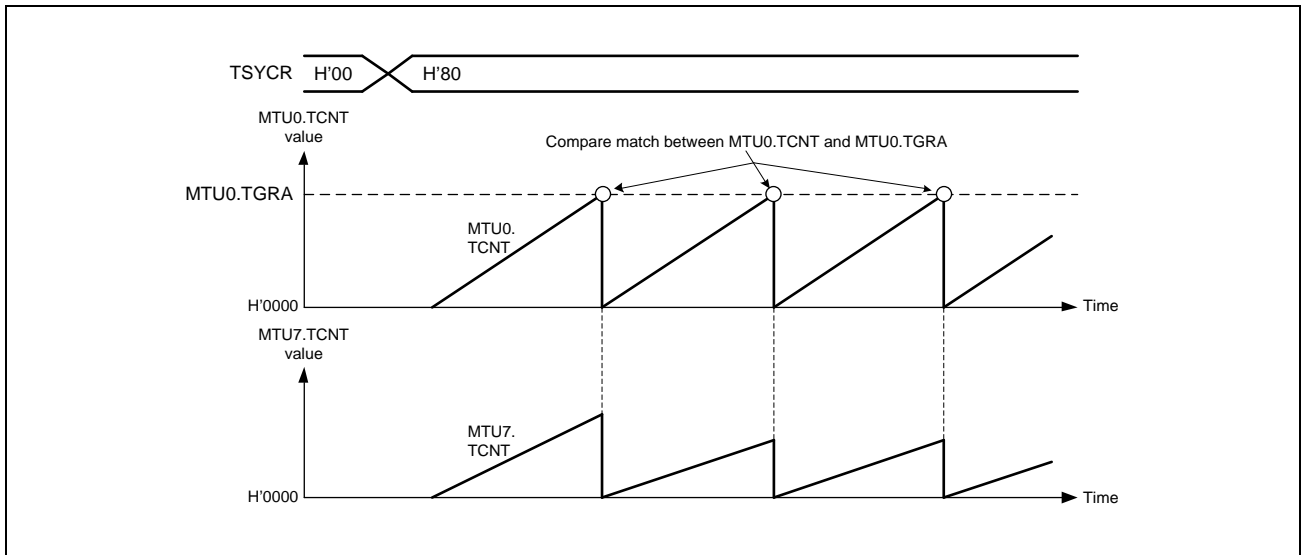

Figure 16.102 Example of Synchronous Counter Clearing in MTU6 and MTU7 (1)

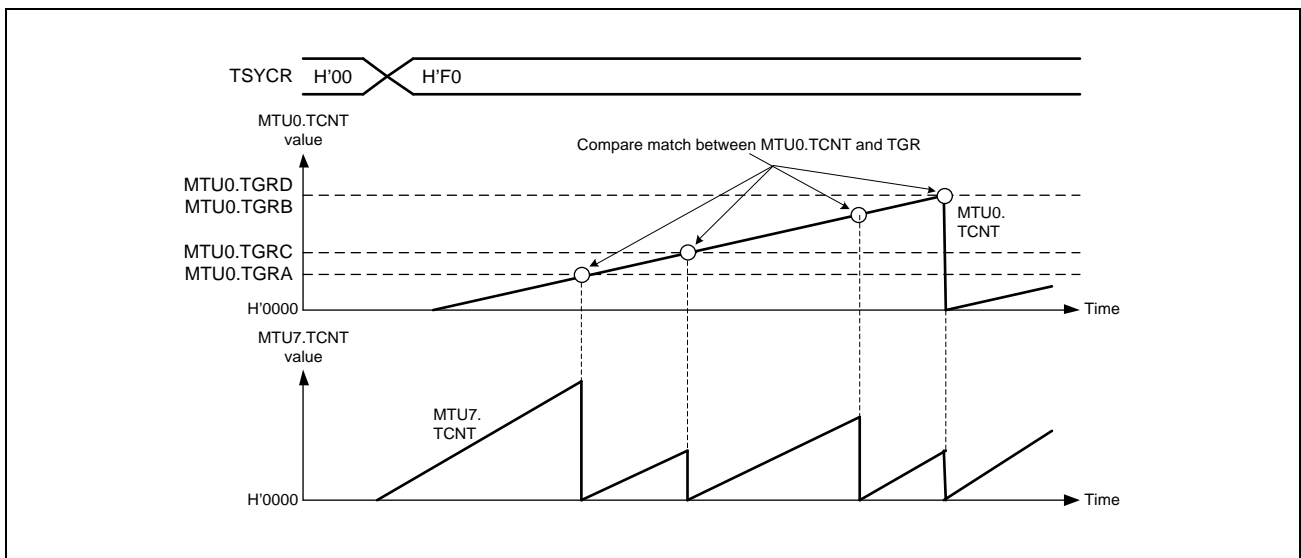

Figure 16.103 Example of Synchronous Counter Clearing in MTU6 and MTU7 (2)

16.3.11 External Pulse Width Measurement

The pulse widths of up to three external input lines can be measured in MTU5.

When the IOC[4:0] bits in MTU5.TIORU, MTU5.TIORV, MTU5.TIORW are set for pulse width measurement, the pulse width of the signal input to the MTIC5U, MTIC5V, and MTIC5W pins are measured. TCNTU, TCNTV, and TCNTW count up while the level specified by the IOC[4:0] bits is input.

Figure 16.104 shows an example of setting external pulse width measurement, and **Figure 16.105** an example of external pulse width measurement.

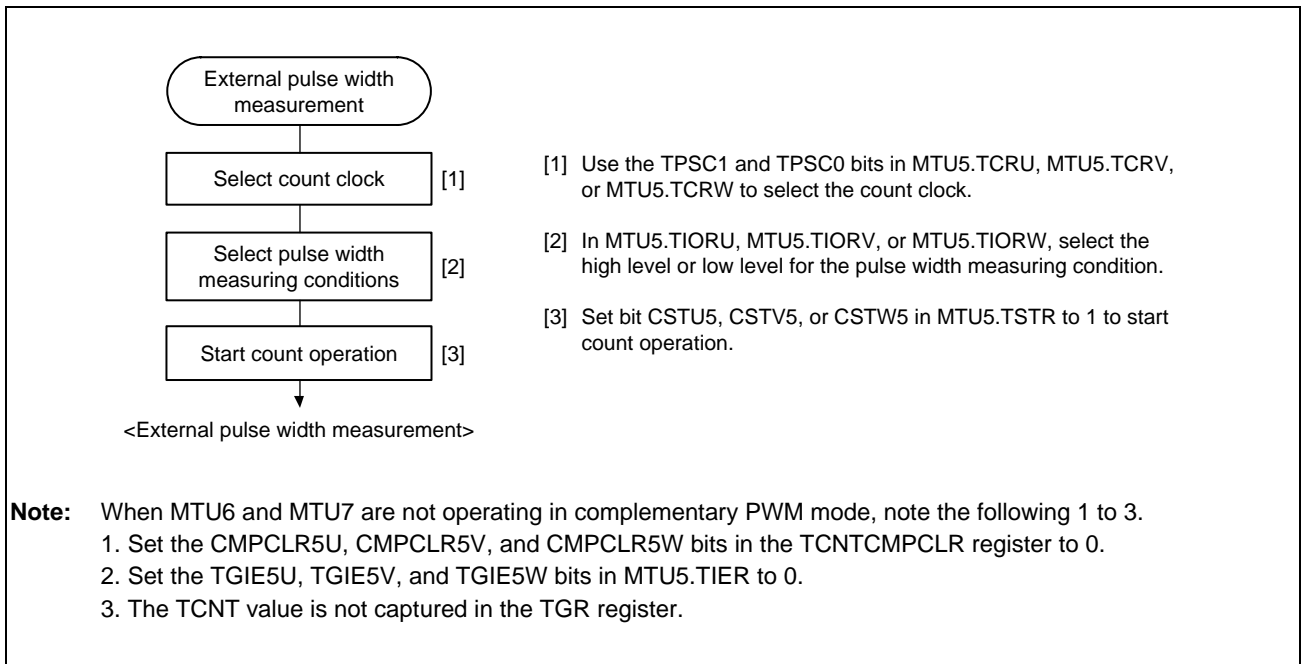

Figure 16.104 Example of External Pulse Width Measurement Setting Procedure

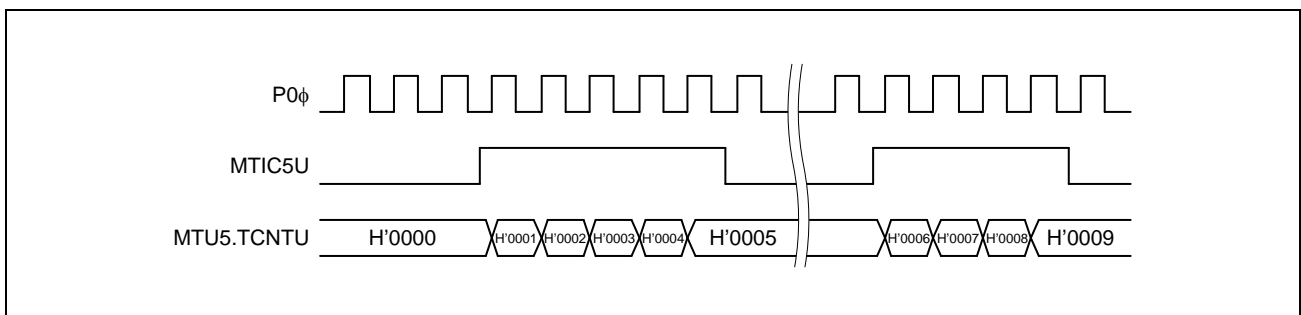

Figure 16.105 Example of External Pulse Width Measurement (Measuring High Pulse Width)

16.3.12 Dead Time Compensation

MTU5 to MTU7 can be used in combination to compensate for the delay in the dead time (the delay between complementary PWM output and inverter output).

Figure 16.106 shows an example of a motor control circuit in which the combination of MTU5 to MTU7 is used to compensate for the dead time delay.

The external pulse measurement function of MTU5 allows the specification of a correction to the duty cycle specified in the PWM output compare registers by measuring the delay between the complementary PWM output and inverter output. This can be used for dead time compensation for the PWM output waveform during complementary PWM operation of MTU6 and MTU7 (**Figure 16.107**).

Figure 16.108 shows the procedure for setting dead time compensation using MTU5 to MTU7. For details on MTU5 operation at this time, refer to **Section 16.3.13, TCNTU, TCNTV, and TCNTW Capture at Crest and/or Trough in Complementary PWM Mode**.

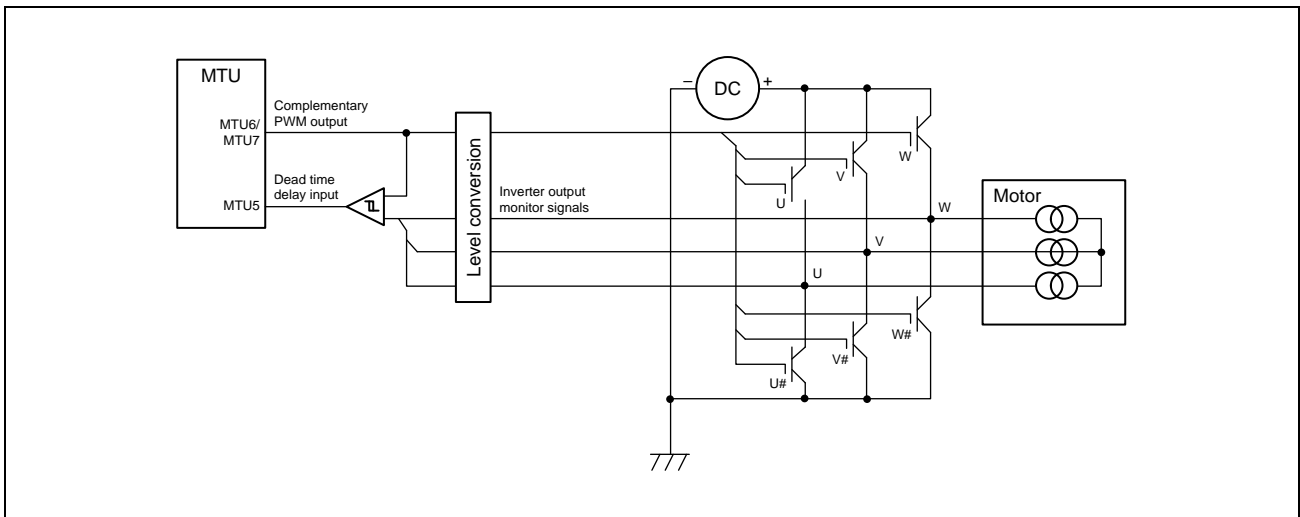

Figure 16.106 Motor Control Circuit Example

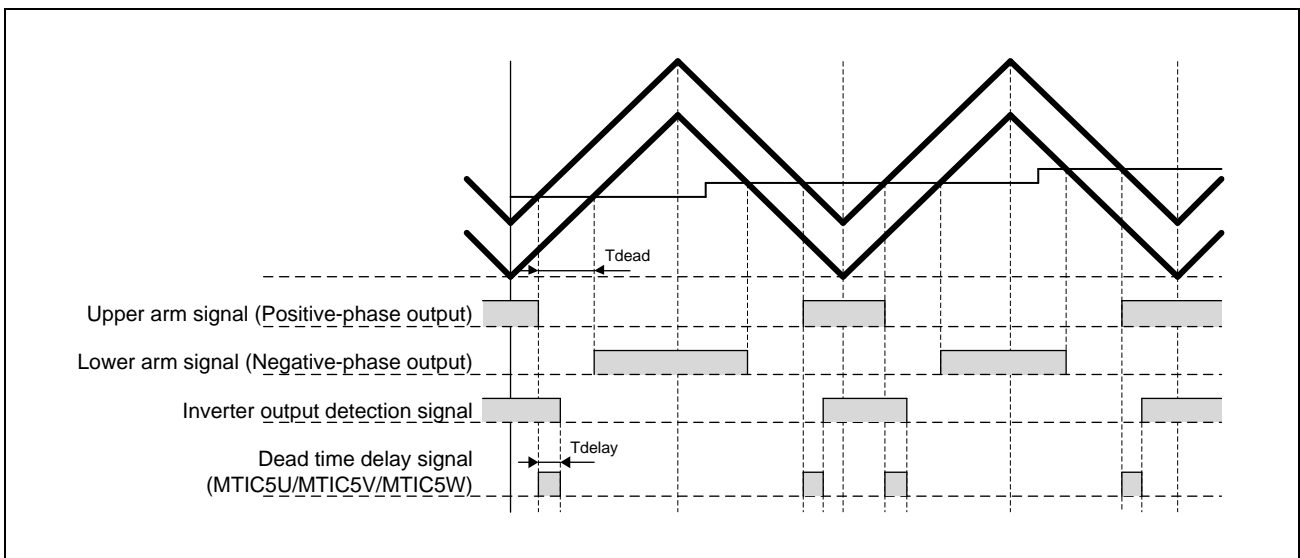

Figure 16.107 Delay in Dead Time in Complementary PWM Operation

(1) Example of Dead Time Compensation Setting Procedure

Figure 16.108 shows an example of dead time compensation setting procedure by using three counters in MTU5.

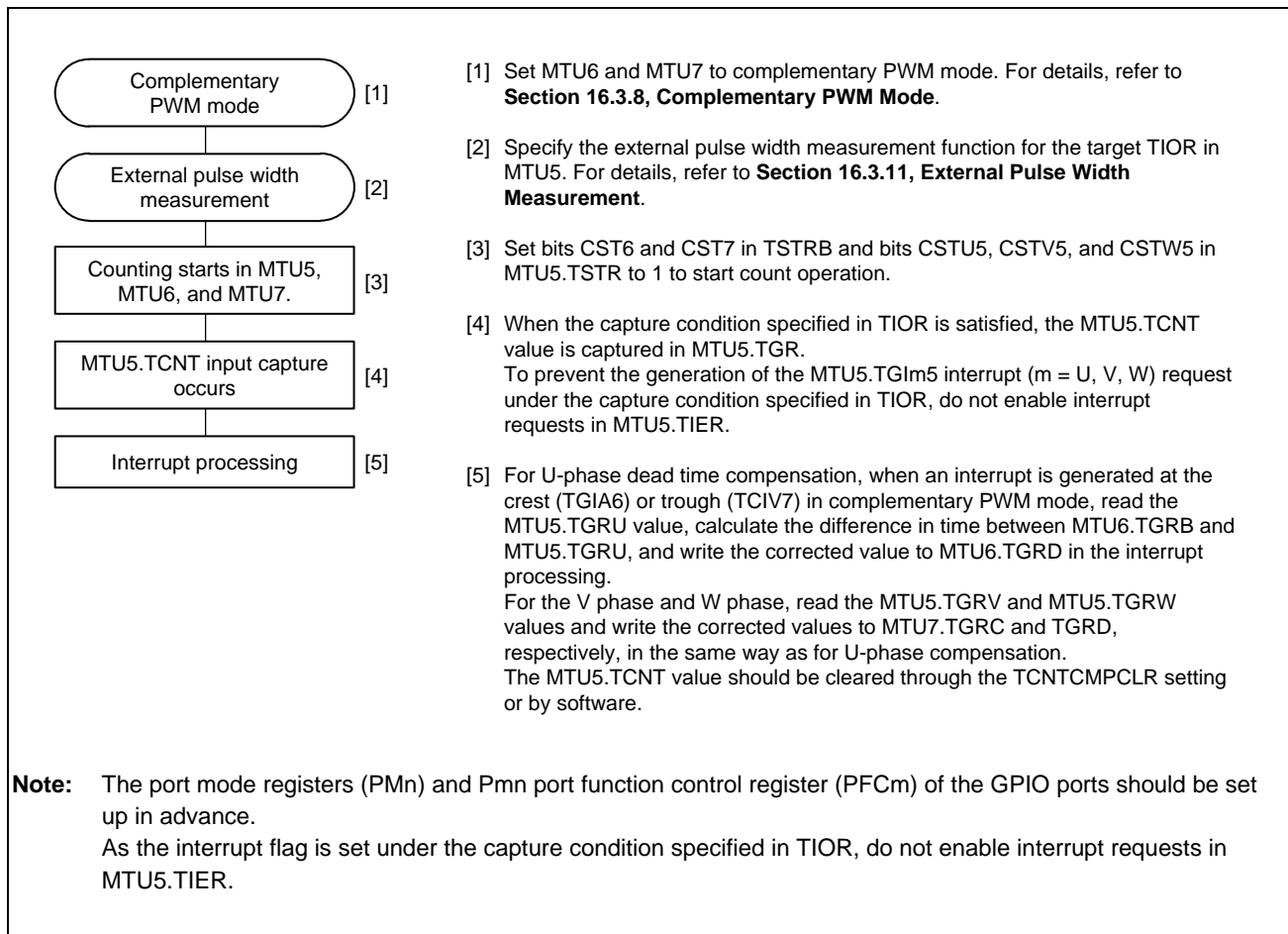

Figure 16.108 Example of Dead Time Compensation Setting Procedure

16.3.13 TCNTU, TCNTV, and TCNTW Capture at Crest and/or Trough in Complementary PWM Mode

The external pulse width measurement function of MTU5 can be used to transfer the values of TCNTU, TCNTV, and TCNTW to TGRU, TGRV, and TGRW at the crests, troughs, or both crests and troughs of the complementary PWM output when MTU6 and MTU7 are being used in complementary PWM mode. The type of transfer timing is specified in TIORU, TIORV, and TIORW. When the CMPCLR5U, CMPCLR5V, and CMPCLR5W bits in the TCNTCNPCR register are set to 1, TCNTU, TCNTV, and TCNTW are cleared to H'0000 at the timing for transfer to TGRU, TGRV, and TGRW.

Note that the TCNTU, TCNTV, and TCNTW capture operation at the crest and/or trough of complementary PWM output in MTU5 is not available when MTU3 and MTU4 are used in complementary PWM mode.

Figure 16.109 shows an operation example in which TCNTU is used as a free-running counter without being cleared and the value is captured in TGRU at the crest and trough in complementary PWM mode.

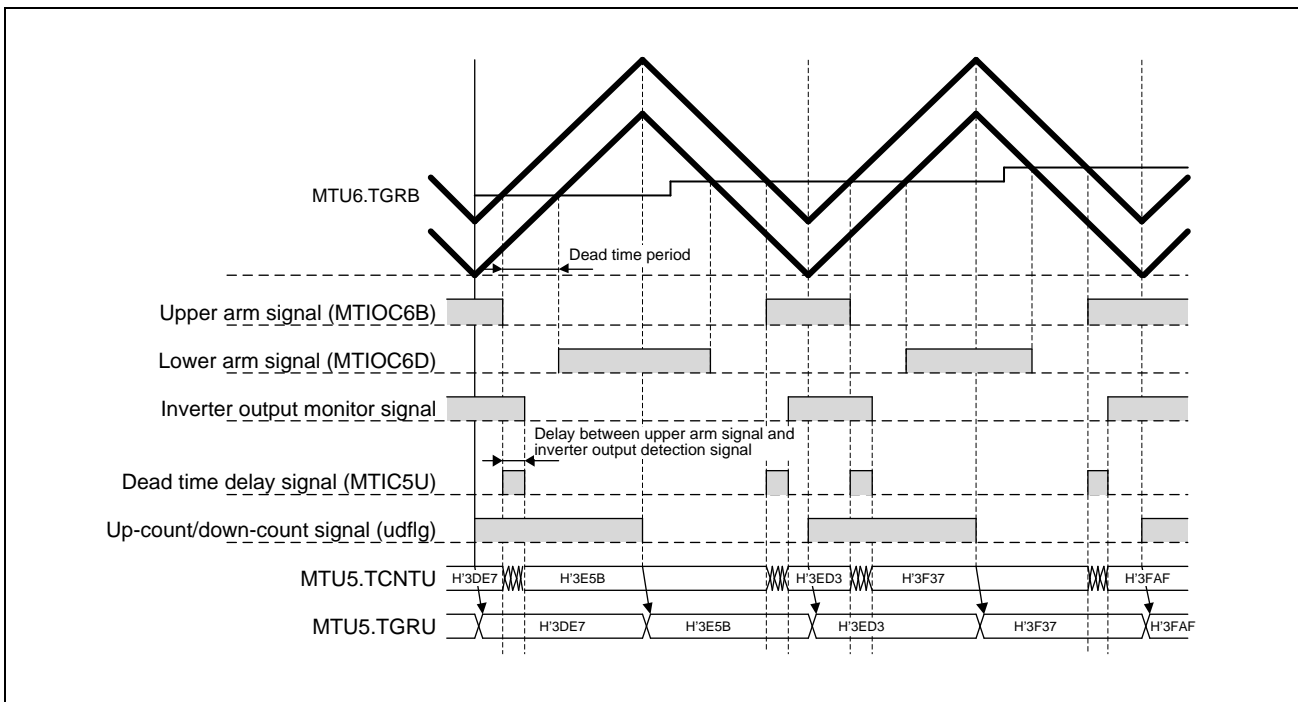

Figure 16.109 TCNTU Capture at Crest and Trough in Complementary PWM Operation

16.3.14 Noise Filter Function

The input capture input pins and external pulse input pins have a noise filter function.

Set the NFCRn register (n = 0 to 7, C) to enable or disable the noise filter function and set the sampling clock. The noise filter for each pin can be enabled or disabled individually, and the sampling clock can be set for each channel.

Figure 16.110 shows the timing of noise filtering.

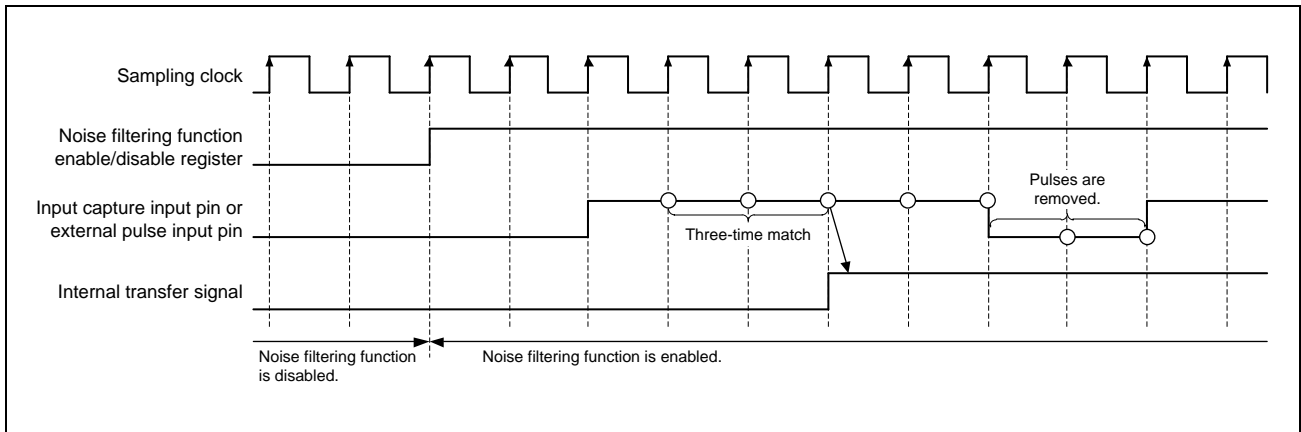

Figure 16.110 Timing of Noise Filtering

16.4 Interrupt Sources

16.4.1 Interrupt Sources and Priorities

There are three kinds of interrupt source; TGR input capture/compare match, TCNT overflow, and TCNT underflow. Each interrupt source has its own enable/disable bit, allowing the generation of interrupt request signals to be enabled or disabled individually.

When an interrupt source is generated, if the corresponding enable/disable bit in TIER is set to 1, an interrupt is requested.

Relative channel priorities can be changed by the interrupt controller; however the priority within a channel is fixed. For details, refer to **Section 8, Interrupt Controller. Table 16.78** lists the MTU interrupt sources.

Table 16.78 MTU Interrupt Sources (1/2)

Channel	Name	Interrupt Source	DMAC Activation
MTU0	TGIA0	MTU0.TGRA input capture/compare match	Possible
	TGIB0	MTU0.TGRB input capture/compare match	Possible
	TGIC0	MTU0.TGRC input capture/compare match	Possible
	TGID0	MTU0.TGRD input capture/compare match	Possible
	TCIV0	MTU0.TCNT overflow	Not possible
	TGIE0	MTU0.TGRE compare match	Not possible
	TGIF0	MTU0.TGRF compare match	Not possible
MTU1	TGIA1	MTU1.TGRA input capture/compare match	Possible
	TGIB1	MTU1.TGRB input capture/compare match	Possible
	TCIV1	MTU1.TCNT overflow	Not possible
	TCIU1	MTU1.TCNT underflow	Not possible
MTU2	TGIA2	MTU2.TGRA input capture/compare match	Possible
	TGIB2	MTU2.TGRB input capture/compare match	Possible
	TCIV2	MTU2.TCNT overflow	Not possible
	TCIU2	MTU2.TCNT underflow	Not possible
MTU3	TGIA3	MTU3.TGRA input capture/compare match	Possible
	TGIB3	MTU3.TGRB input capture/compare match	Possible
	TGIC3	MTU3.TGRC input capture/compare match	Possible
	TGID3	MTU3.TGRD input capture/compare match	Possible
	TCIV3	MTU3.TCNT overflow	Not possible
MTU4	TGIA4	MTU4.TGRA input capture/compare match	Possible
	TGIB4	MTU4.TGRB input capture/compare match	Possible
	TGIC4	MTU4.TGRC input capture/compare match	Possible
	TGID4	MTU4.TGRD input capture/compare match	Possible
	TCIV4	MTU4.TCNT overflow/underflow* ¹	Possible
MTU5	TGIU5	MTU5.TGRU input capture/compare match	Possible
	TGIV5	MTU5.TGRV input capture/compare match	Possible
	TGIW5	MTU5.TGRW input capture/compare match	Possible
MTU6	TGIA6	MTU6.TGRA input capture/compare match	Possible
	TGIB6	MTU6.TGRB input capture/compare match	Possible
	TGIC6	MTU6.TGRC input capture/compare match	Possible
	TGID6	MTU6.TGRD input capture/compare match	Possible
	TCIV6	MTU6.TCNT overflow	Not possible

Table 16.78 MTU Interrupt Sources (2/2)

Channel	Name	Interrupt Source	DMAC Activation
MTU7	TGIA7	MTU7.TGRA input capture/compare match	Possible
	TGIB7	MTU7.TGRB input capture/compare match	Possible
	TGIC7	MTU7.TGRC input capture/compare match	Possible
	TGID7	MTU7.TGRD input capture/compare match	Possible
	TCIV7	MTU7.TCNT overflow/underflow*1	Possible
MTU8	TGIA8	MTU8.TGRA input capture/compare match	Possible
	TGIB8	MTU8.TGRB input capture/compare match	Possible
	TGIC8	MTU8.TGRC input capture/compare match	Possible
	TGID8	MTU8.TGRD input capture/compare match	Possible
	TCIV8	MTU8.TCNT overflow	Possible

Note: This table shows the initial state immediately after a reset. The relative channel priorities can be changed by the interrupt controller.

Note 1. The underflow interrupt source is valid only in complementary PWM mode.

(1) Input Capture/Compare Match Interrupt

If the TIER.TGIE bit is set to 1 when a TGR input capture/compare match occurs on a channel, an interrupt is requested. The MTU has 33 input capture/compare match interrupts (six for MTU0, four each for MTU3, MTU4, MTU6, MTU7, and MTU8, two each for MTU1 and MTU2, and three for MTU5).

(2) Overflow Interrupt

If the TIER.TCIEV bit is set to 1 when a TCNT overflow occurs on a channel, clearing an interrupt is requested. The MTU provides a total of eight overflow interrupts (one for each channel except MTU5).

In complementary PWM mode, an overflow interrupt is generated even when an underflow occurs in TCNT in MTU4 or MTU7.

(3) Underflow Interrupt

If the TIER.TCIEU bit is set to 1 when a TCNT underflow occurs on a channel, an interrupt is requested. The MTU has two underflow interrupts (one each for MTU1, and MTU2).

16.4.2 DMAC Activation

(1) DMAC Activation

The DMAC can be activated by the TGR input capture/compare match interrupt and the overflow interrupt in MTU4 and MTU7. For details, see **Section 14, Direct Memory Access Controller**.

The MTU provides a total of 33 interrupts (input capture/compare match and overflow interrupts) that can be used as DMAC activation sources: four each for MTU0, MTU3, MTU6, and MTU8, two each for MTU1 and MTU2, five each for MTU4 and MTU7, and three for MTU5.

16.4.3 A/D Converter Activation

The A/D converter can be activated by one of the following three methods in the MTU. **Table 16.79** shows the relationship between interrupt sources and A/D converter start request signals.

(1) A/D Converter Activation by TGRA Input Capture/Compare Match or at MTU4.TCNT (MTU7.TCNT) Trough in Complementary PWM Mode

The A/D converter can be activated by the occurrence of a TGRA input capture/compare match in each channel. In addition, if complementary PWM operation is performed while the TTGE2 bit in MTU4.TIER (MTU7.TIER) is set to 1, the A/D converter can be activated at the trough of MTU4.TCNT (MTU7.TCNT) count ($MTU4.TCNT (MTU7.TCNT) = H'0000$).

A/D converter start request signal TRGAnN is issued to the A/D converter under either of the following conditions (n = 0 to 4, 6, or 7).

- When a TGRA input capture/compare match occurs on a channel while the TIER.TTG bit is set to 1
- When the MTU4.TCNT (MTU7.TCNT) count reaches the trough ($MTU4.TCNT (MTU7.TCNT) = H'0000$) during complementary PWM operation while the TTGE2 bit in MTU4.TIER (MTU7.TIER) is set to 1

When either condition is satisfied, if A/D converter start signal TRGAnN from the MTU is selected as the trigger in the A/D converter, A/D conversion will start.

(2) A/D Converter Activation by Compare Match between MTU0.TCNT and MTU0.TGRE

A/D converter start request signal TRG0N is issued to the A/D converter when a compare match occurs between MTU0.TCNT and MTU0.TGRE.

When a compare match occurs between MTU0.TCNT and MTU0.TGRE in MTU0 while the TTGE2 bit.TIER2 is set to 1, A/D converter start request TGR0N is issued to the A/D converter. If A/D converter start signal TRG0N from the MTU is selected as the trigger in the A/D converter, A/D conversion will start.

(3) A/D Converter Activation by A/D Converter Start Request Delaying Function

The A/D converter can be activated by generating A/D converter start request signal TRG4AN or TRG4BN (TRG7AN or TRG7BN) when the MTU4.TCNT (MTU7.TCNT) count matches the MTU4.TADCORA or MTU4.TADCORB (MTU7.TADCORA or MTU7.TADCORB) value if the UT4AE, DT4AE, UT4BE, or DT4BE (UT7AE, DT7AE, UT7BE, or DT7BE) bit in the A/D converter start request control register (MTU4.TADCR (MTU7.TADCR)) is set to 1. For details, refer to **Section 16.3.9, A/D Converter Start Request Delaying Function**.

A/D conversion will start when TRG4AN (TRG7AN) is generated if A/D converter start signal TRG4AN (TRG7AN) from the MTU is selected as the trigger in the A/D converter, when TRG4BN (TRG7BN) is generated if TRG4BN (TRG7BN) from the MTU is selected as the trigger in the A/D converter, or when TRG4ABN (TRG7ABN) is generated if TRG4ABN (TRG7ABN) from the MTU is selected as the trigger in the A/D converter.

Table 16.79 Interrupt Sources and A/D Converter Start Request Signals

Target Registers	Interrupt Source	A/D Converter Start Request Signal
MTU0.TGRA and MTU0.TCNT	Input capture/compare match	TRGA0N
MTU1.TGRA and MTU1.TCNT		TRGA1N
MTU2.TGRA and MTU2.TCNT		TRGA2N
MTU3.TGRA and MTU3.TCNT		TRGA3N
MTU4.TGRA and MTU4.TCNT* ¹		TRGA4N
MTU4.TCNT	MTU4.TCNT trough in complementary PWM mode	
MTU6.TGRA and MTU6.TCNT	Input capture/compare match	TRGA6N
MTU7.TGRA and MTU7.TCNT* ¹		TRGA7N
MTU7.TCNT	MTU7.TCNT trough in complementary PWM mode	
MTU0.TGRE and MTU0.TCNT	Compare match	TRG0N
MTU4.TADCORA and MTU4.TCNT		TRG4AN
MTU4.TADCORB and MTU4.TCNT		TRG4BN
MTU7.TADCORA and MTU7.TCNT		TRG7AN
MTU7.TADCORB and MTU7.TCNT		TRG7BN
MTU4.TADCORA and MTU4.TCNT, MTU4.TADCORB and MTU4.TCNT	Compare match (interrupt skipping function 2)	TRG4ABN
MTU7.TADCORA and MTU7.TCNT, MTU7.TADCORB and MTU7.TCNT		TRG7ABN

Note 1. Since PWM waveforms are generated in complementary PWM mode, MTU4.TGRA (MTU7.TGRA) compare match not only with MTU4.TCNT (MTU7.TCNT) but also with MTU3.TCNT (MTU6.TCNT) and TCNTSA (TCNTSB) is detected. Accordingly, when compare match with MTU3.TCNT (MTU6.TCNT) and TCNTSA (TCNTSB) occurs, TRGA4N (TRGA7N) is also generated.

When MTU3 and MTU 4 (MTU 6 and MTU7) are made to operate in complementary PWM mode for generating an A/D converter start request, use the A/D converter start request by compare match between MTU4.TCNT (MTU7.TCNT) and MTU4.TADCORA or TADCORB (MTU7.TADCORA or TADCORB).

16.5 Operation Timing

16.5.1 Input/Output Timing

(1) TCNT Count Timing

Figure 16.111 and Figure 16.112 show the TCNT count timing in internal clock operation, Figure 16.113 shows the TCNT count timing in external clock operation (normal mode), and Figure 16.114 shows the TCNT count timing in external clock operation (phase counting mode).

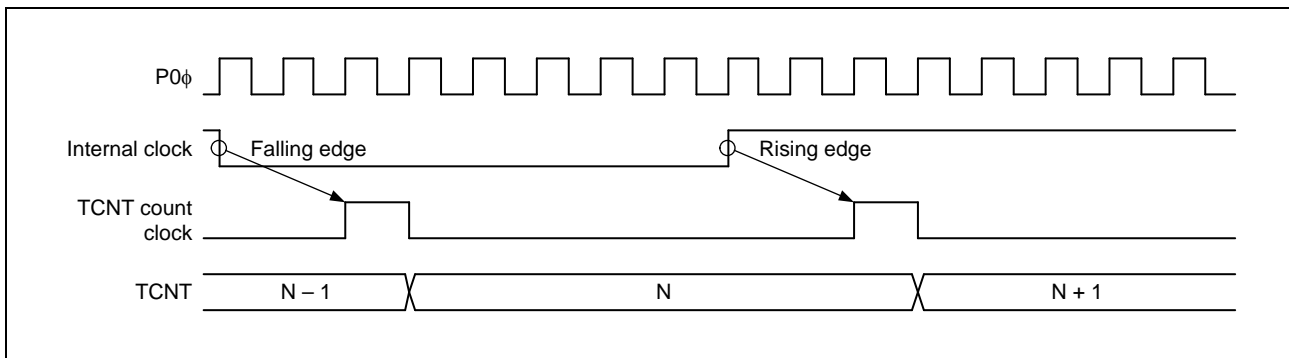

Figure 16.111 Count Timing in Internal Clock Operation (MTU0 to MTU4 and MTU6 to MTU8)

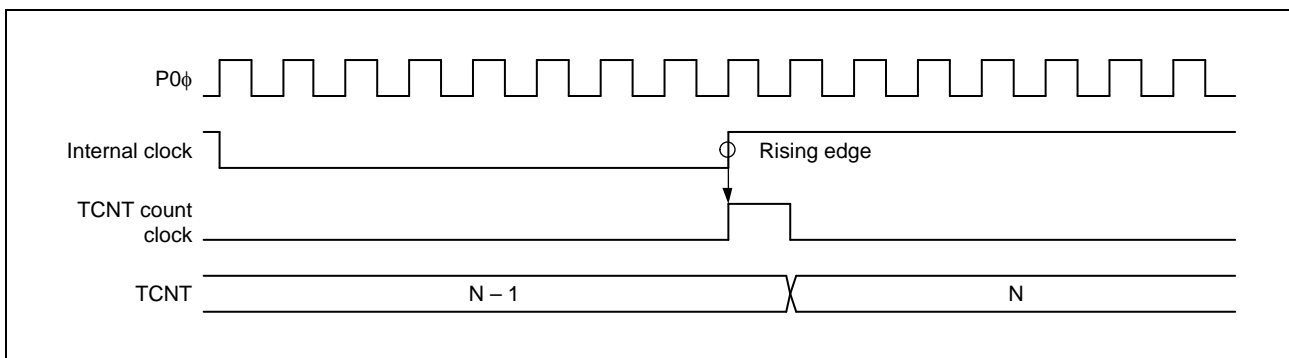

Figure 16.112 Count Timing in Internal Clock Operation (MTU5)

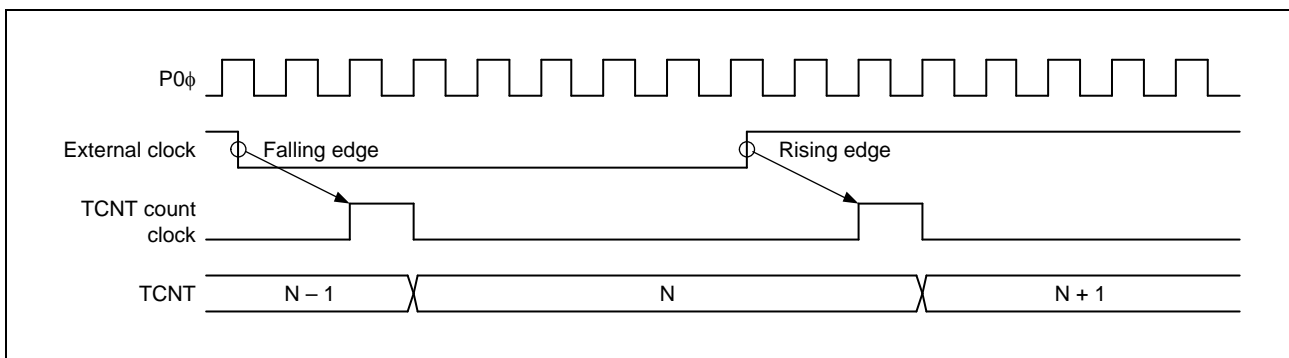

Figure 16.113 Count Timing in External Clock Operation (MTU0 to MTU4, MTU6 to MTU8)

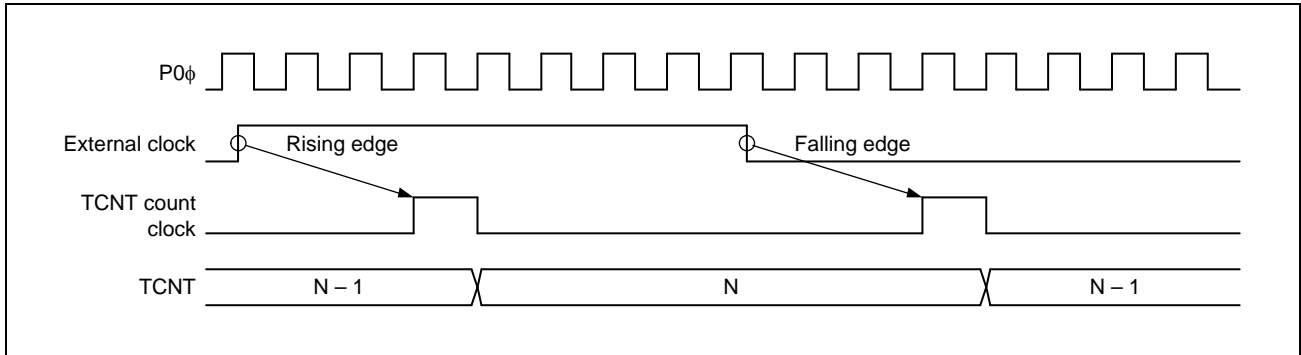
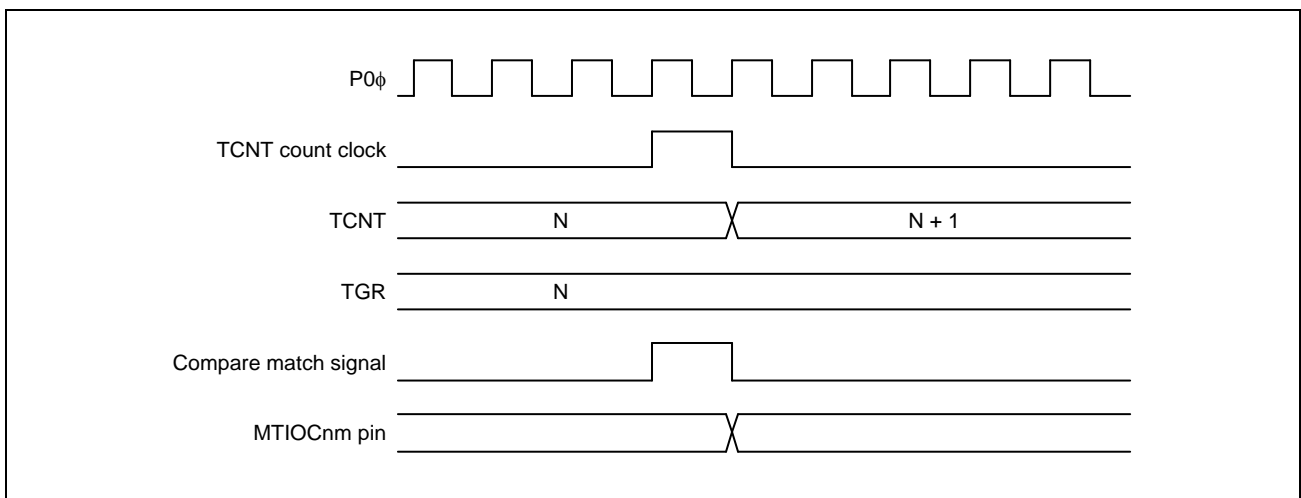

Figure 16.114 Count Timing in External Clock Operation (Phase Counting Mode)

(2) Output Compare Output Timing

A compare match signal is generated in the final state in which TCNT and TGR match (the point at which the count value matched by TCNT is updated). When a compare match signal is generated, the value set in TIOR is output from MTIOCnm pin ($n = 0$ to 4, 6, 7, 8; $m = A$ to D). After a match between TCNT and TGR, the compare match signal is not generated until the TCNT count clock is generated.

Figure 16.115 shows the output compare output timing (normal mode or PWM mode) and **Figure 16.116** shows the output compare output timing (complementary PWM mode or reset-synchronized PWM mode).

Figure 16.115 Output Compare Output Timing (Normal Mode or PWM Mode) ($n = 0$ to 4, 6, 7, 8; $m = A$ to D)

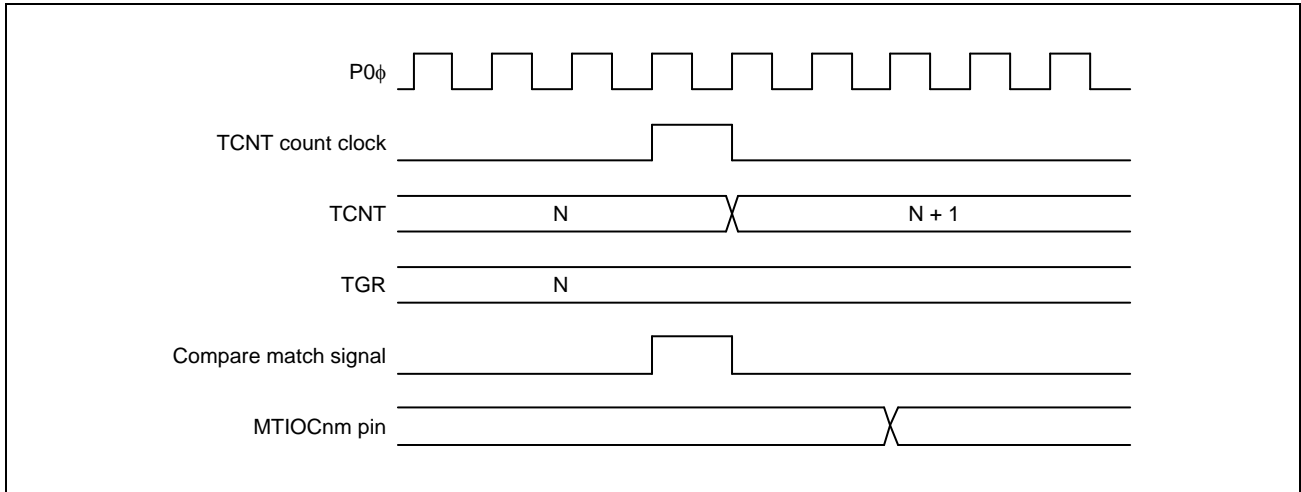

Figure 16.116 Output Compare Output Timing (Complementary PWM Mode or Reset-Synchronized PWM Mode)
 (n = 0 to 4, 6, 7, 8; m = A to D)

(3) Input Capture Signal Timing

Figure 16.117 shows the input capture signal timing.

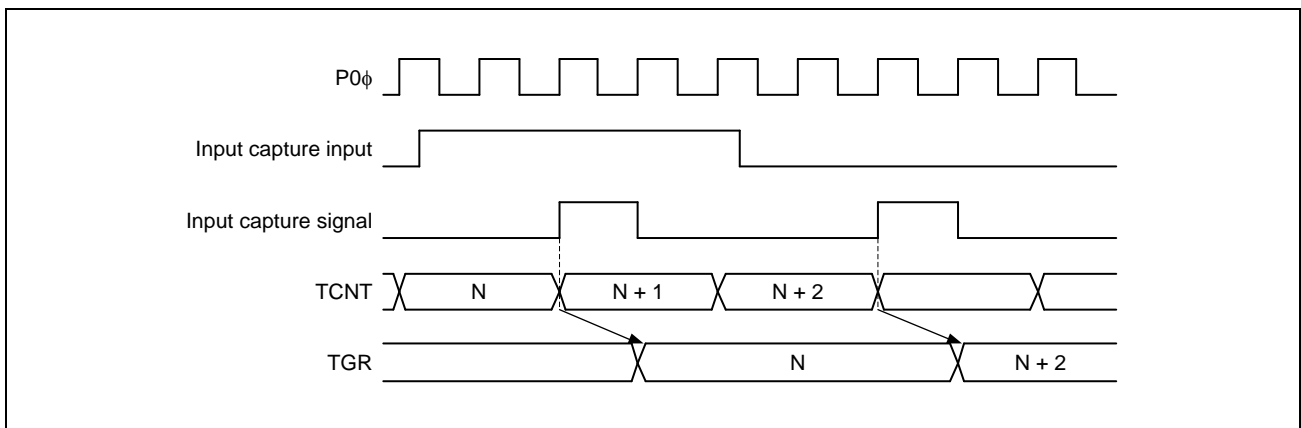

Figure 16.117 Input Capture Input Signal Timing

(4) Timing for Counter Clearing by Compare Match/Input Capture

Figure 16.118 and **Figure 16.119** show the timing when counter clearing on compare match is specified, and **Figure 16.120** shows the timing when counter clearing on input capture is specified.

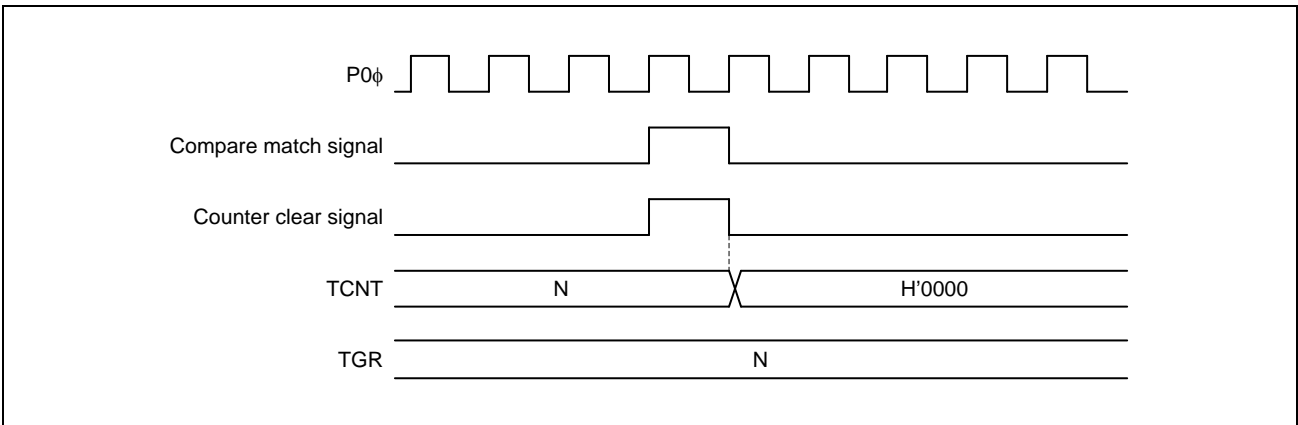

Figure 16.118 Counter Clear Timing (Compare Match) (MTU0 to MTU4 and MTU6 to MTU8)

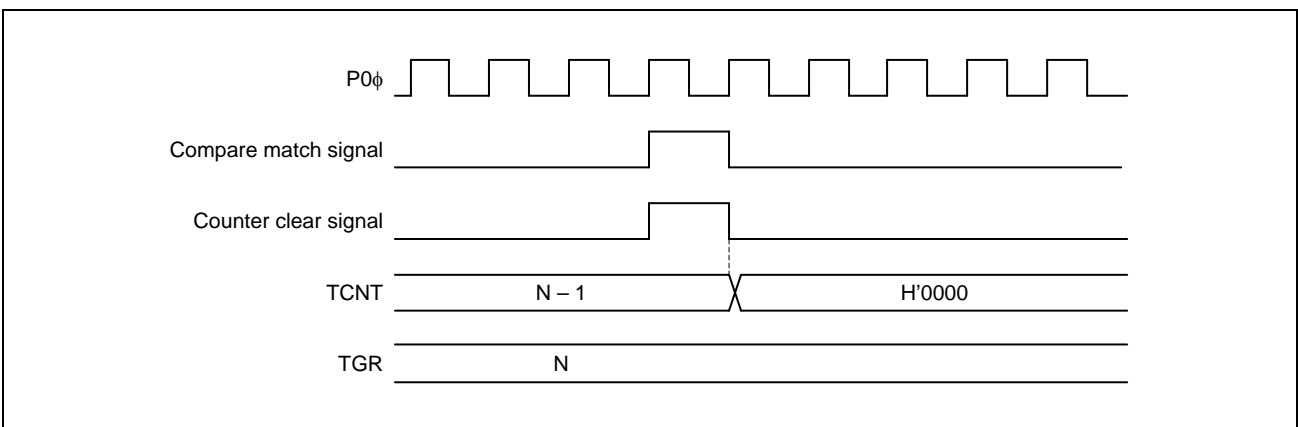

Figure 16.119 Counter Clear Timing (Compare Match) (MTU5)

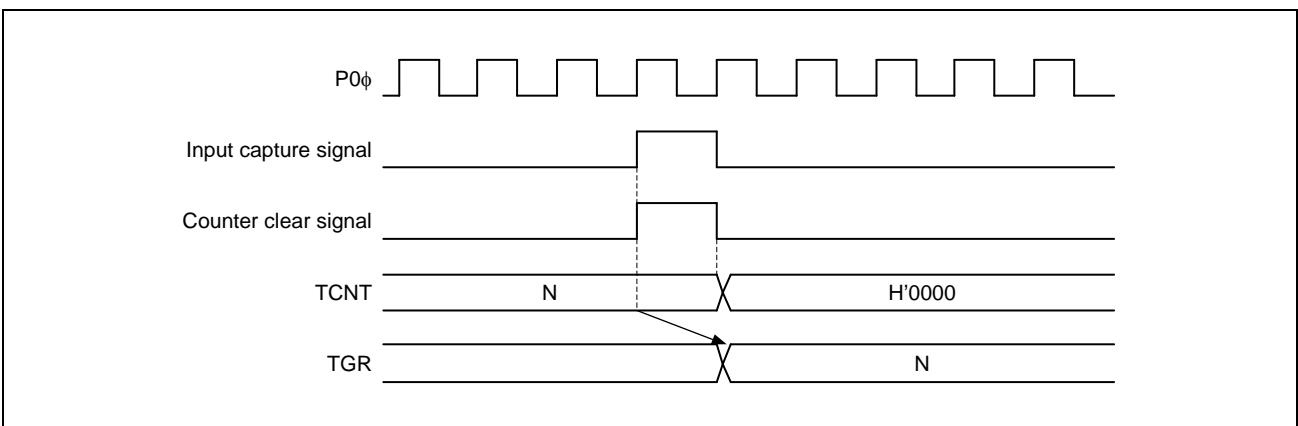

Figure 16.120 Counter Clear Timing (Input Capture) (MTU0 to MTU8)

(5) Buffer Operation Timing

Figure 16.121 to Figure 16.123 show the timing in buffer operation.

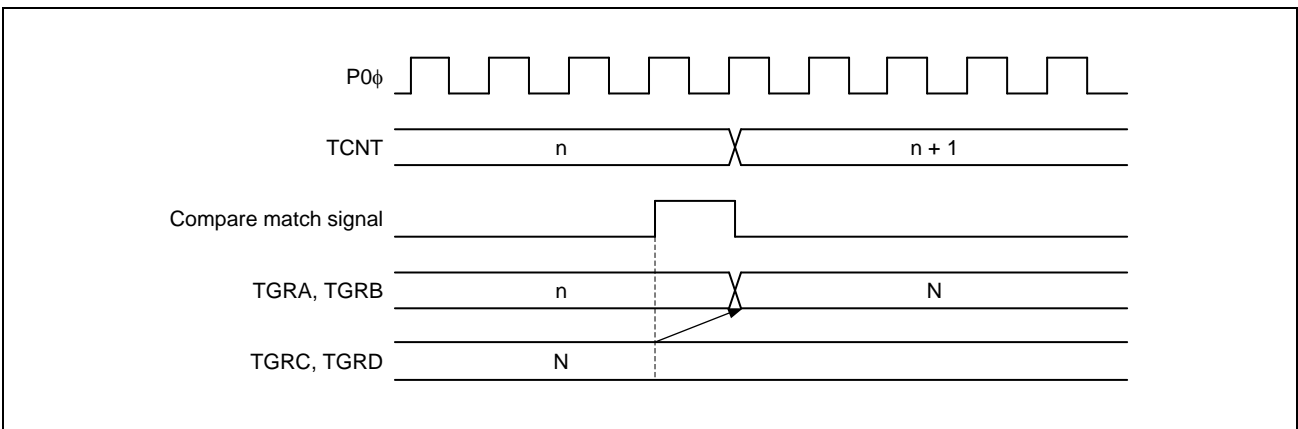

Figure 16.121 Buffer Operation Timing (Compare Match)

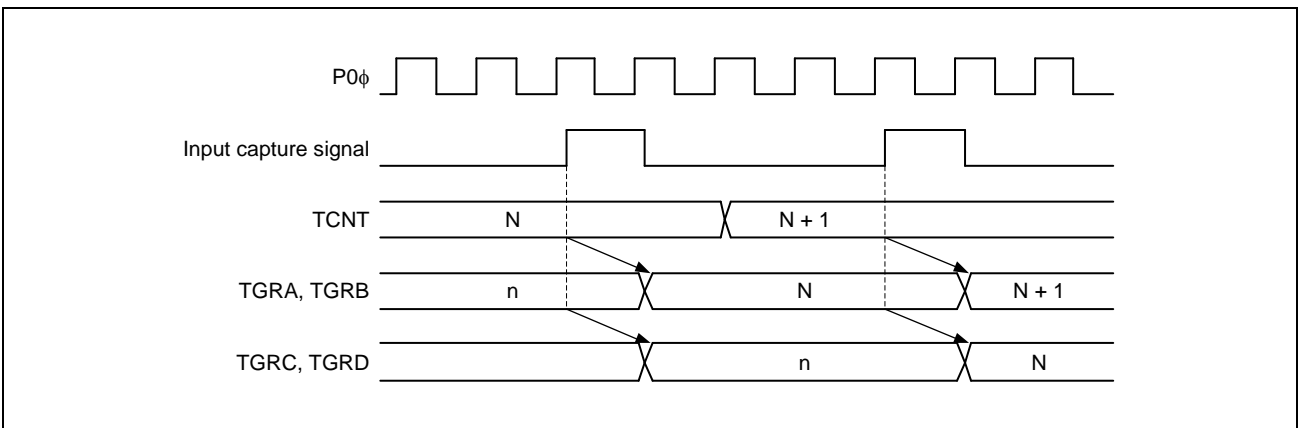

Figure 16.122 Buffer Operation Timing (Input Capture)

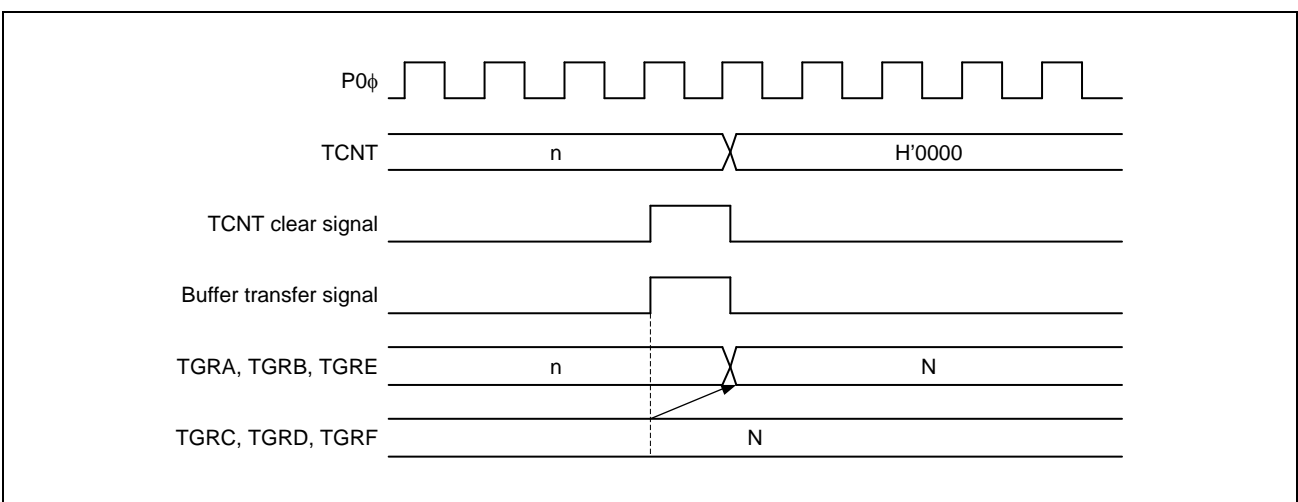

Figure 16.123 Buffer Operation Timing (When TCNT Cleared)

(6) Buffer Transfer Timing (Complementary PWM Mode)

Figure 16.124 to Figure 16.126 show the buffer transfer timing in complementary PWM mode.

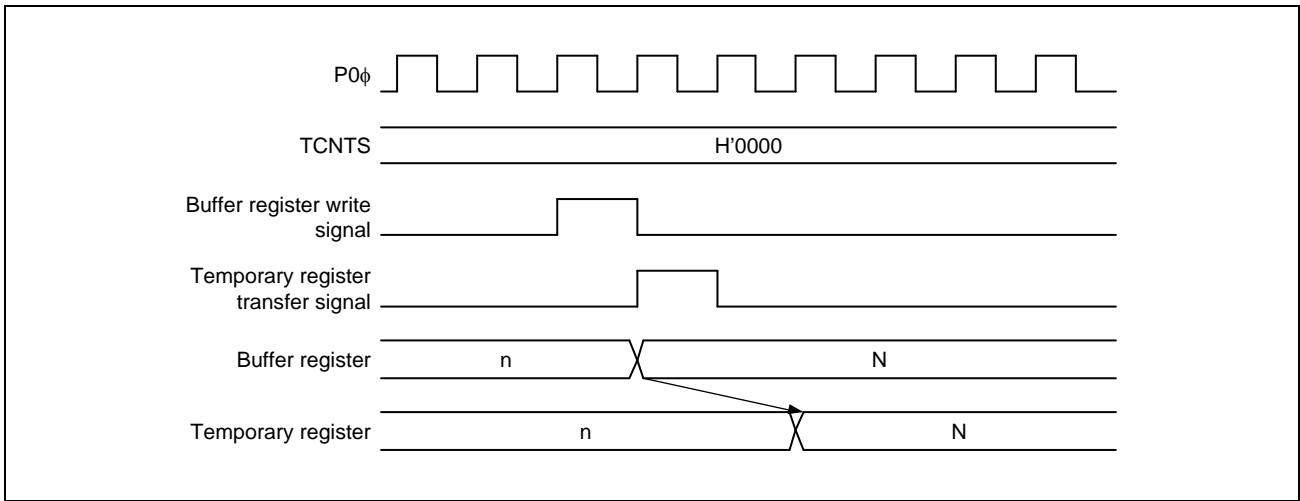

Figure 16.124 Transfer Timing from Buffer Register to Temporary Register (TCNTSA Stopped)

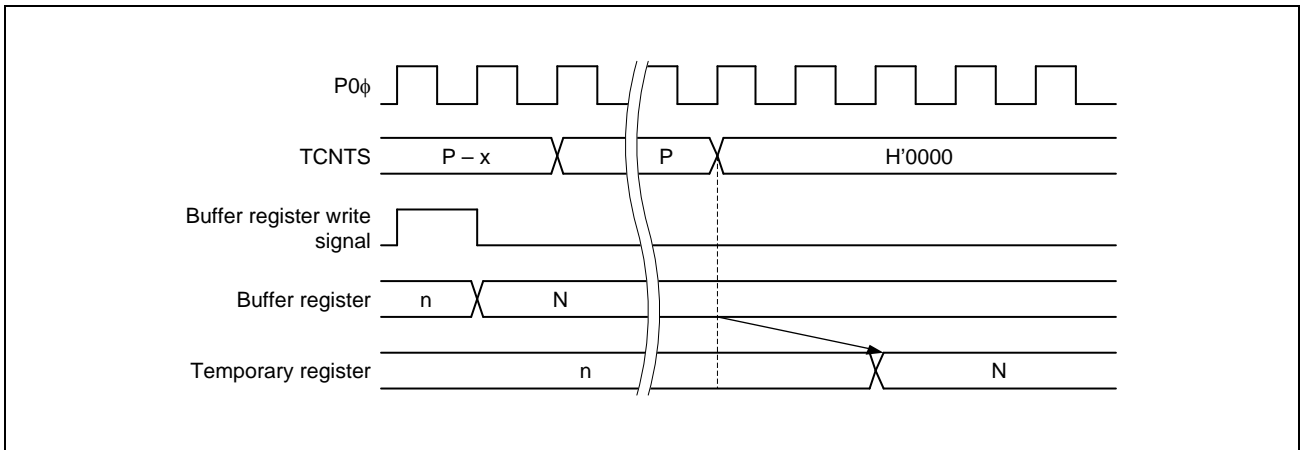

Figure 16.125 Transfer Timing from Buffer Register to Temporary Register (TCNTSA Operating)

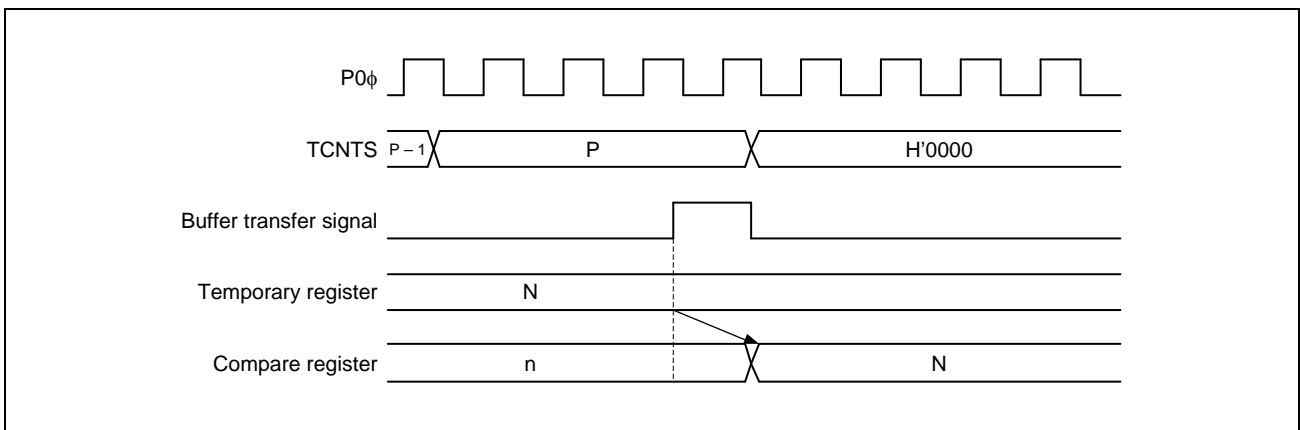

Figure 16.126 Transfer Timing from Temporary Register to Compare Register

16.5.2 Interrupt Signal Timing

(1) TGI Interrupt Timing by Compare Match

Figure 16.127 and Figure 16.128 show the TGI interrupt request signal timing when a compare match occurs.

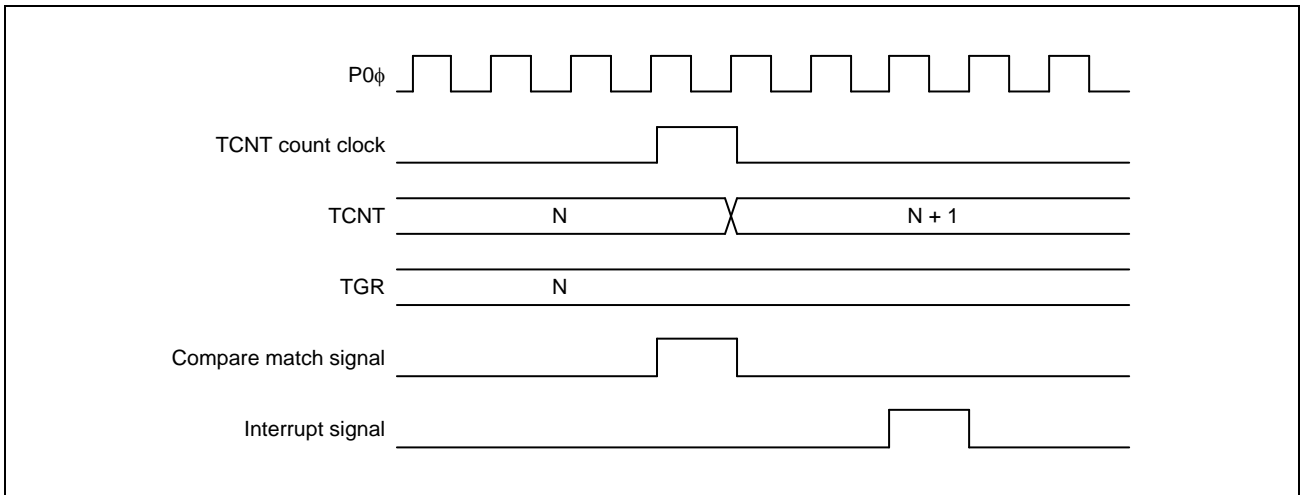

Figure 16.127 TGI Interrupt Timing (Compare Match) (MTU0 to MTU4 and MTU6 to MTU8)

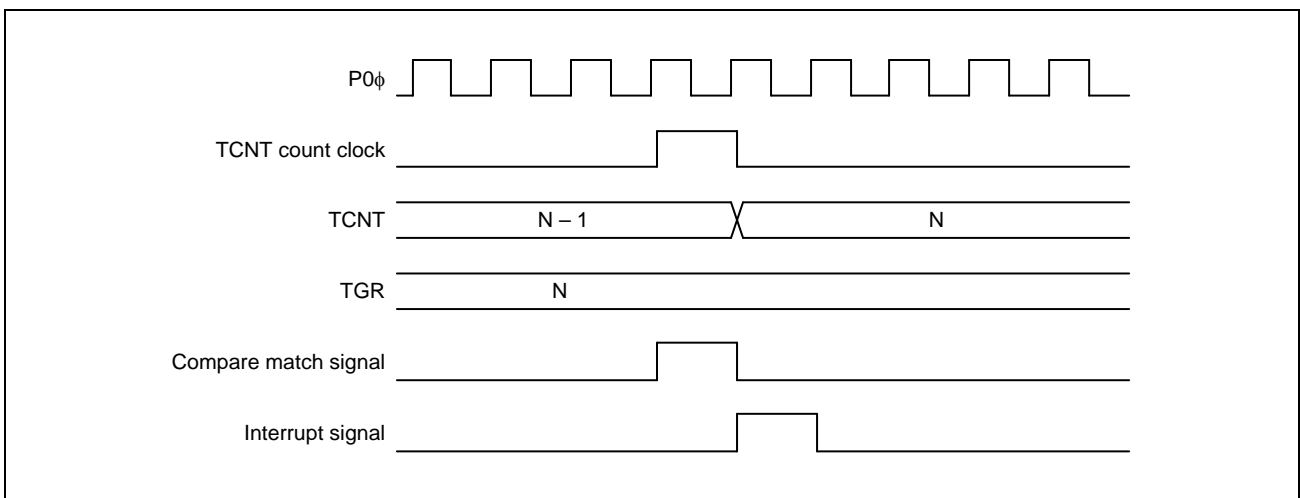

Figure 16.128 TGI Interrupt Timing (Compare Match) (MTU5)

(2) TGI Interrupt Timing by Input Capture

Figure 16.129 and Figure 16.130 show the TGI interrupt request signal timing when an input capture occurs.

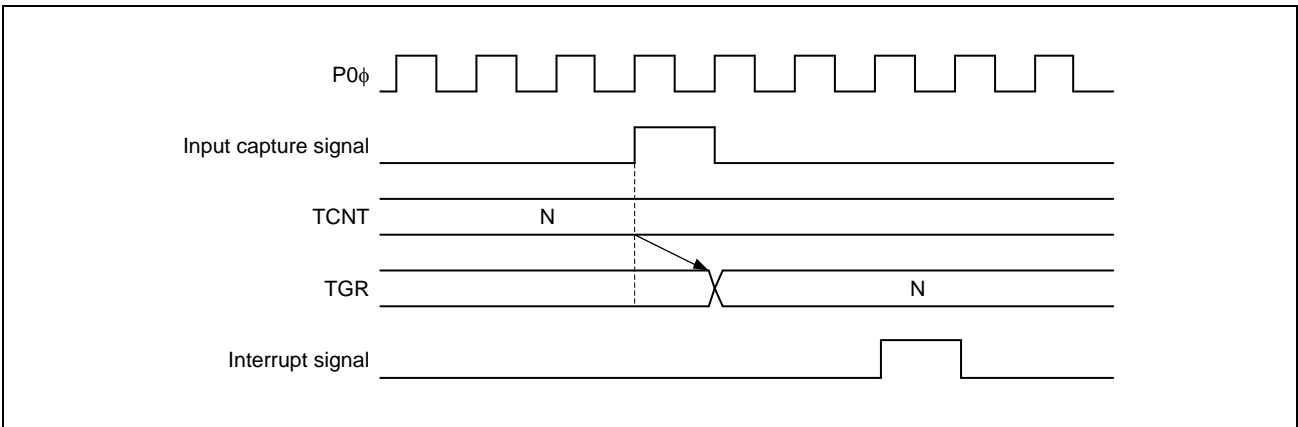

Figure 16.129 TGI Interrupt Timing (Input Capture) (MTU0 to MTU4 and MTU6 to MTU8)

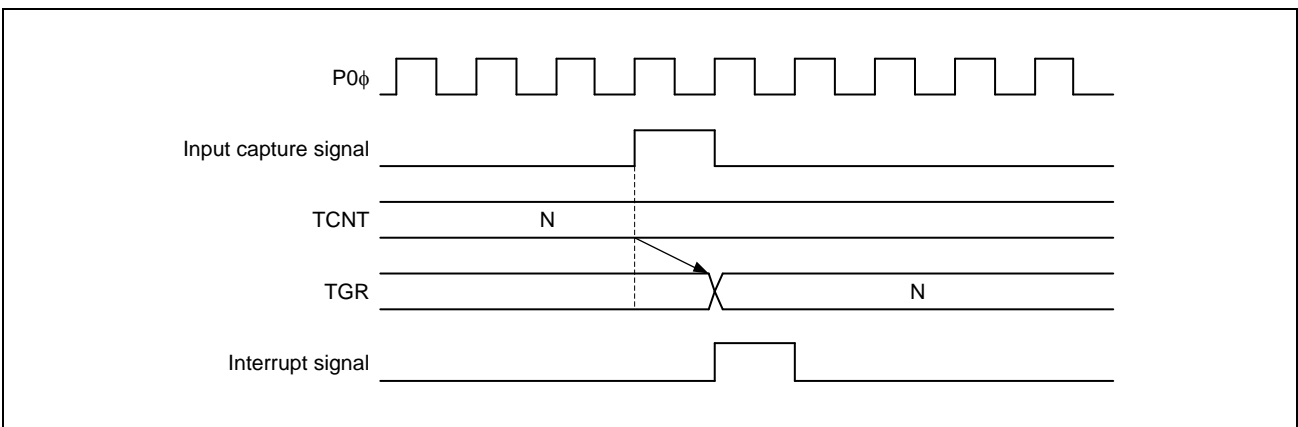

Figure 16.130 TGI Interrupt Timing (Input Capture) (MTU5)

(3) TCFV and TCFU Interrupt Timing

Figure 16.131 shows the TCIV interrupt request signal timing when an overflow is generated.

Figure 16.132 shows the TCIU interrupt request signal timing when an underflow is generated.

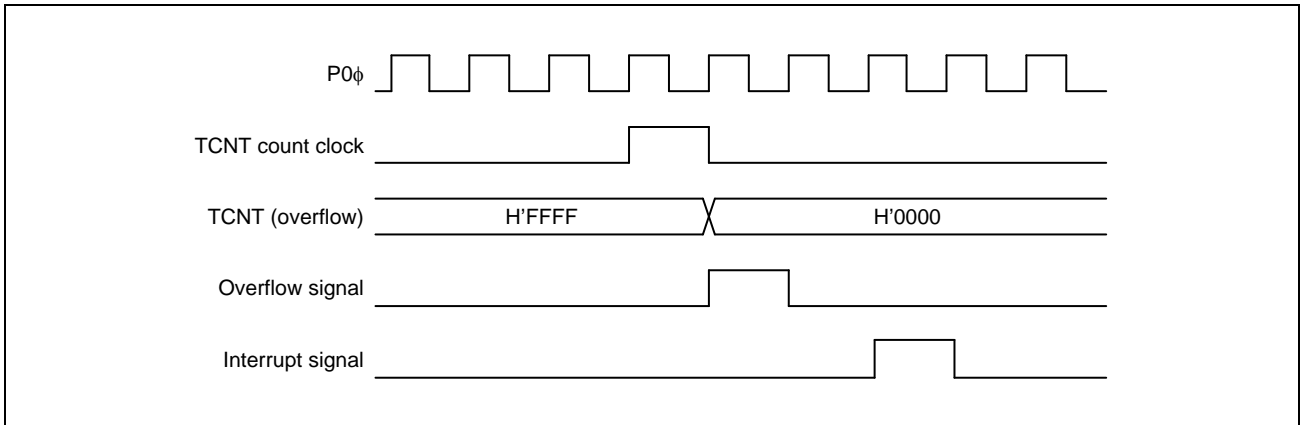

Figure 16.131 TCIV Interrupt Timing

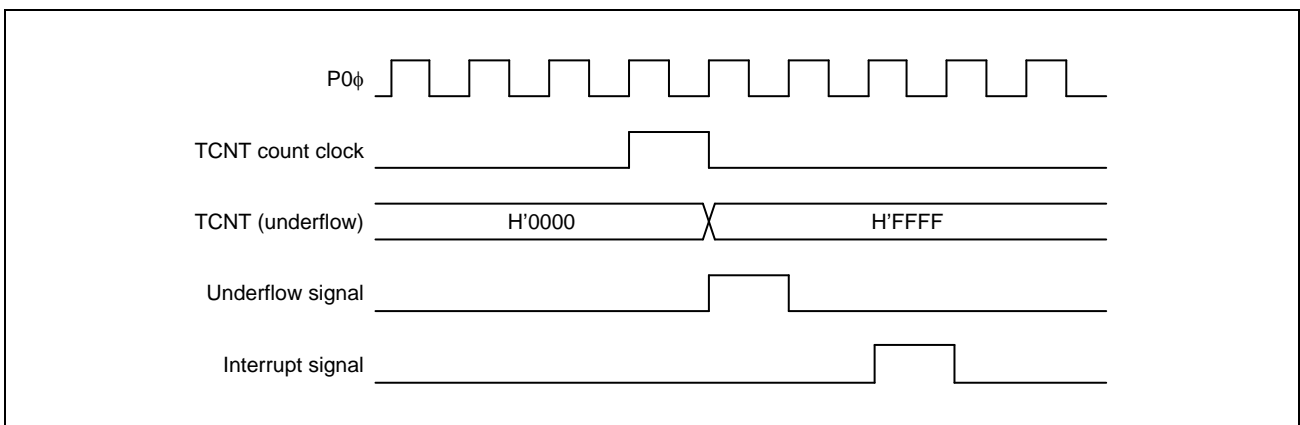

Figure 16.132 TCIU Interrupt Timing

16.6 Usage Note

16.6.1 Count Clock Restrictions

The count clock source pulse width must be at least three $P0\phi$ clock cycles for single-edge detection, and at least five $P0\phi$ clock cycles for both-edge detection. The MTU will not operate properly at narrower pulse widths.

In phase counting mode, the phase difference and overlap between the two input clocks must be at least three $P0\phi$ clock cycles, and the pulse width must be at least $5P0\phi$ clock cycles. **Figure 16.133** shows the input clock conditions in phase counting mode.

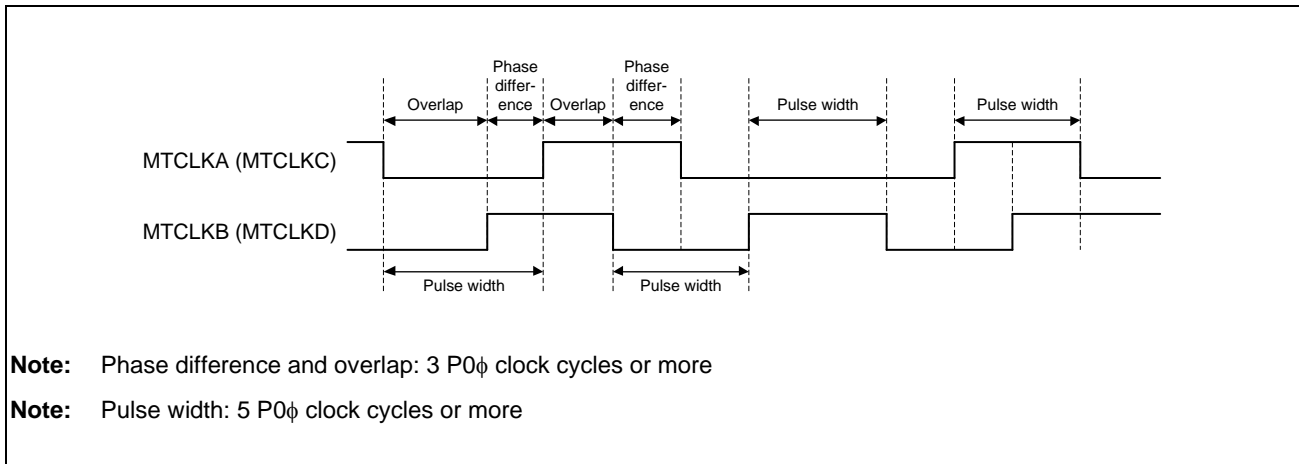

Figure 16.133 Phase Difference, Overlap, and Pulse Width in Phase Counting Mode

16.6.2 Note on Cycle Setting

When counter clearing on compare match is set, TCNT is cleared in the final state in which it matches the TGR value (the point at which TCNU updates the matched count value). Consequently, the actual counter frequency is given by the following formula:

- MTU0 to MTU4 and MTU6 to MTU8

$$f = \frac{\text{CNTCLK}}{N + 1}$$

- MTU5

$$f = \frac{\text{CNTCLK}}{N}$$

f: Counter frequency

CNTCLK: The count clock frequency set by TCR.TPSC[2:0] and TCR2.TPSC2[2:0]

N: TGR setting

16.6.3 Contention between TCNT Write and Clear Operations

If the counter clear signal is generated in the TCNT write cycle, TCNT clearing takes precedence and TCNT write operation is not performed.

Figure 16.134 shows the timing in this case.

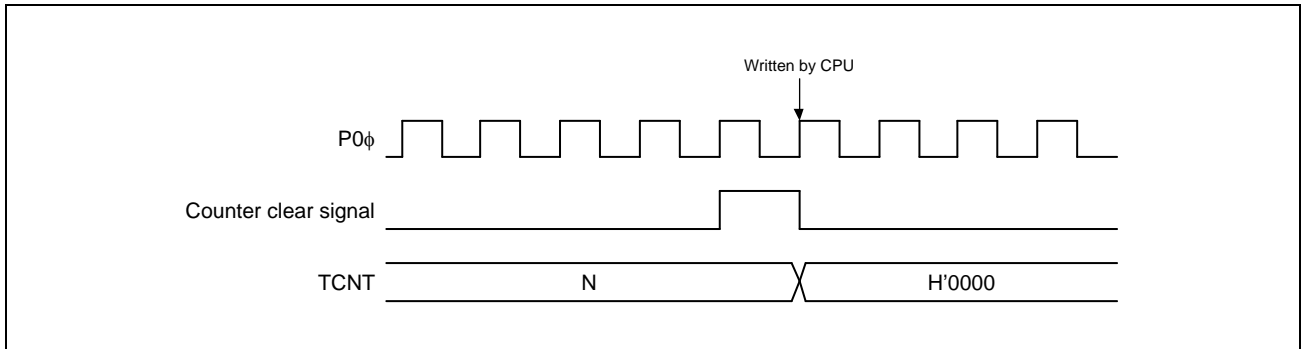

Figure 16.134 Contention between TCNT Write and Clear Operations

16.6.4 Contention between TCNT Write and Increment Operations

If incrementing occurs in a TCNT write cycle, TCNT write operation takes precedence and TCNT is not incremented.

Figure 16.135 shows the timing in this case.

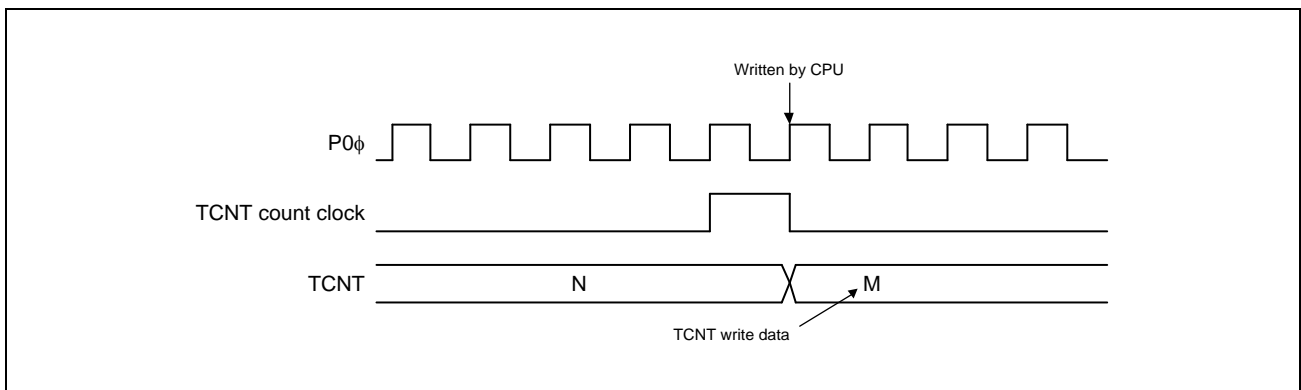

Figure 16.135 Contention between TCNT Write and Increment Operations

16.6.5 Contention between TGR Write Operation and Compare Match

If a compare match occurs in a TGR write cycle, TGR write operation is executed and the compare match signal is also generated.

Figure 16.136 shows the timing in this case.

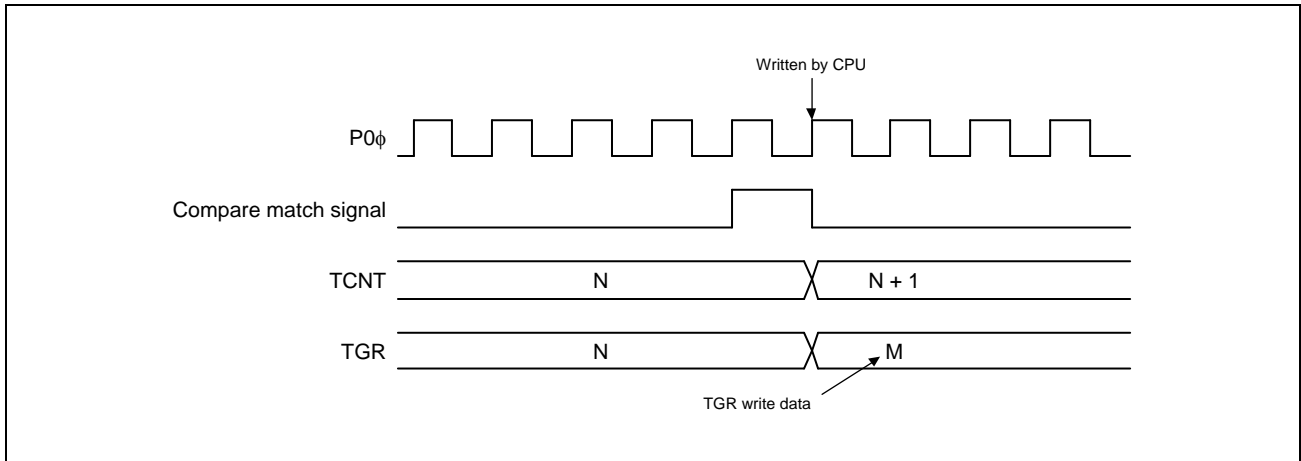

Figure 16.136 Contention between TGR Write Operation and Compare Match

16.6.6 Contention between Buffer Register Write Operation and Compare Match

If a compare match occurs in the T2 state in a TGR write cycle, the data before write operation is transferred to TGR by the buffer operation.

Figure 16.137 shows the timing in this case.

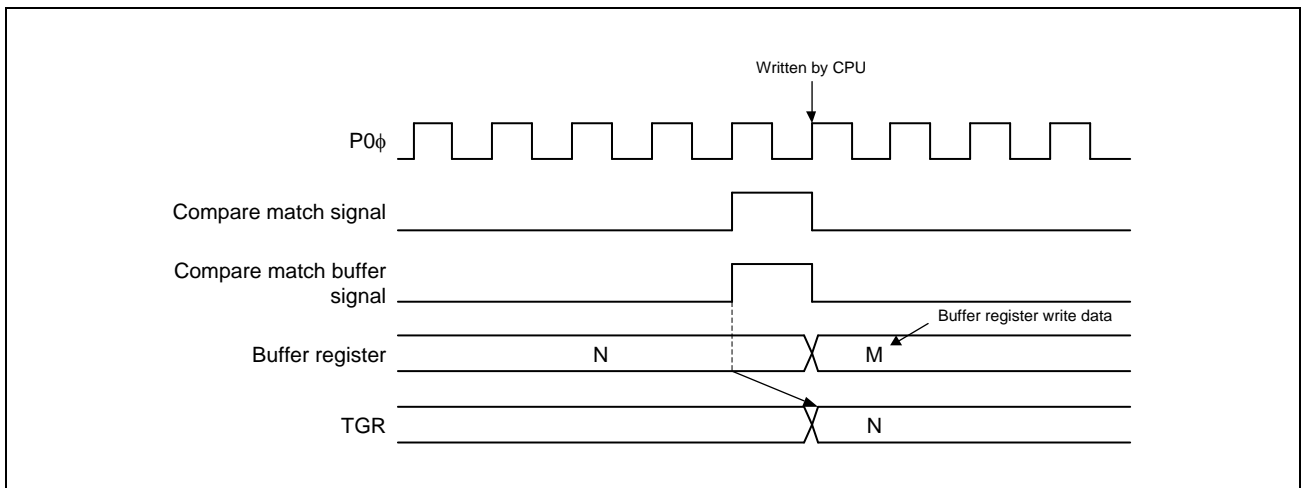

Figure 16.137 Contention between Buffer Register Write Operation and Compare Match

16.6.7 Contention between Buffer Register Write and TCNT Clear Operations

When the buffer transfer timing is set to the TCNT clear timing by the timer buffer transfer mode register (TBTM), if TCNT is cleared during the TGR write cycle, the data before write operation is transferred to TGR by the buffer operation.

Figure 16.138 shows the timing in this case.

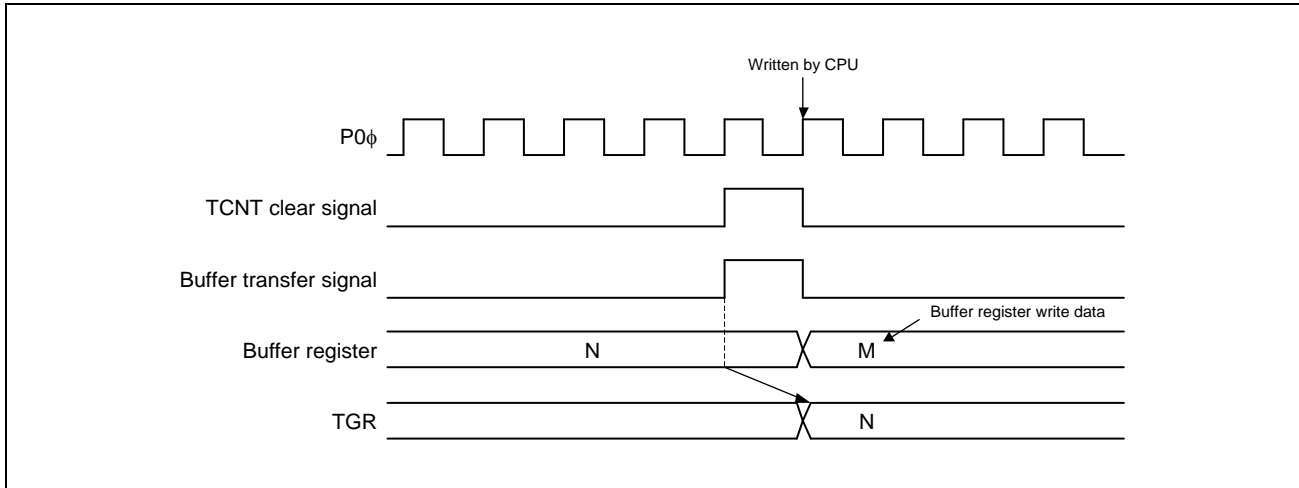

Figure 16.138 Contention between Buffer Register Write and TCNT Clear Operations

16.6.8 Contention between TGR Read Operation and Input Capture

If an input capture signal is generated in a TGR read cycle, the data before input capture transfer is read.

Figure 16.139 shows the timing in this case.

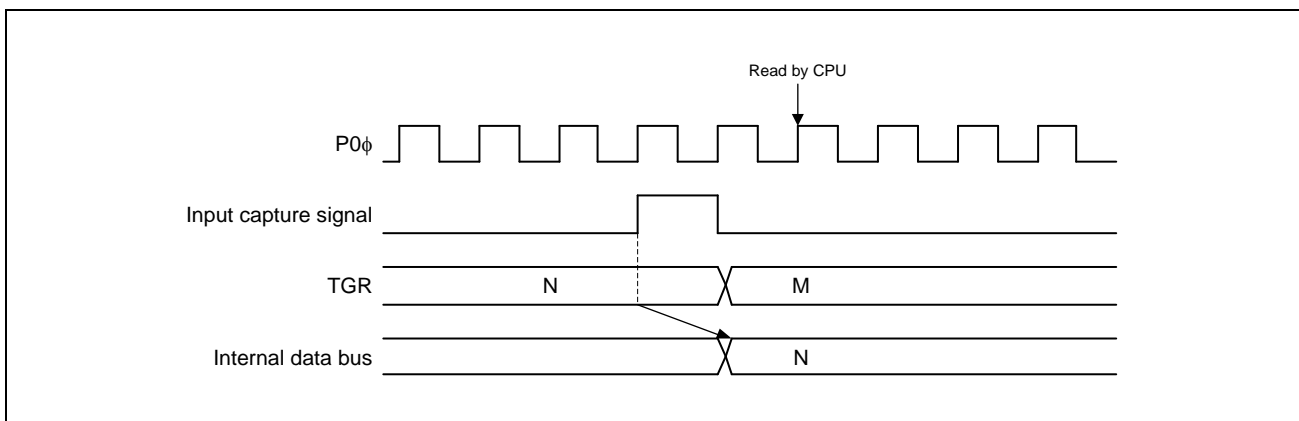

Figure 16.139 Contention between TGR Read Operation and Input Capture (MTU0 to MTU8)

16.6.9 Contention between TGR Write Operation and Input Capture

If an input capture signal is generated in the TGR write cycle, the input capture operation takes precedence and the TGR write operation is not performed in MTU0 to MTU4 and MTU6 to MTU8. In MTU5, the TGR write operation is performed and the input capture signal is generated.

Figure 16.140 and Figure 16.141 show the timing in this case.

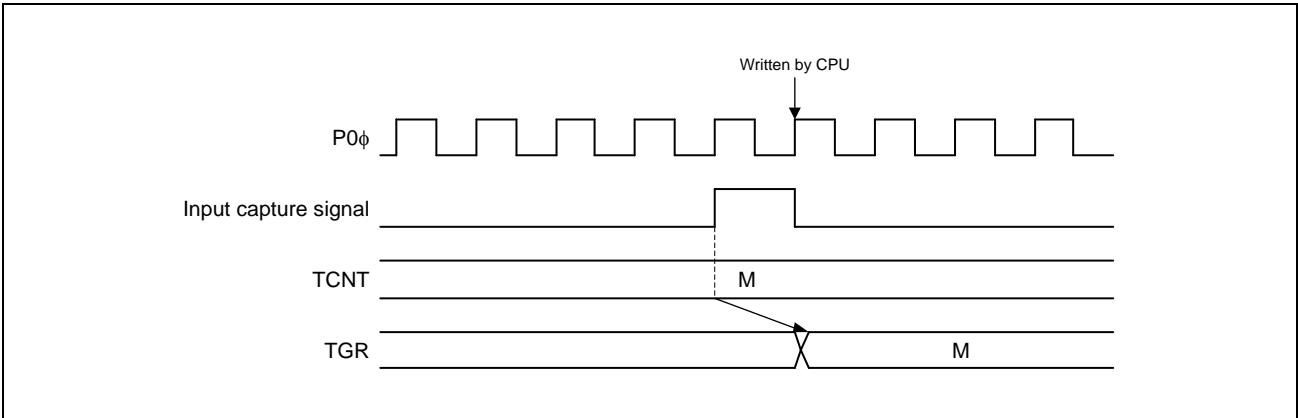

Figure 16.140 Contention between TGR Write Operation and Input Capture (MTU0 to MTU4 and MTU6 to MTU8)

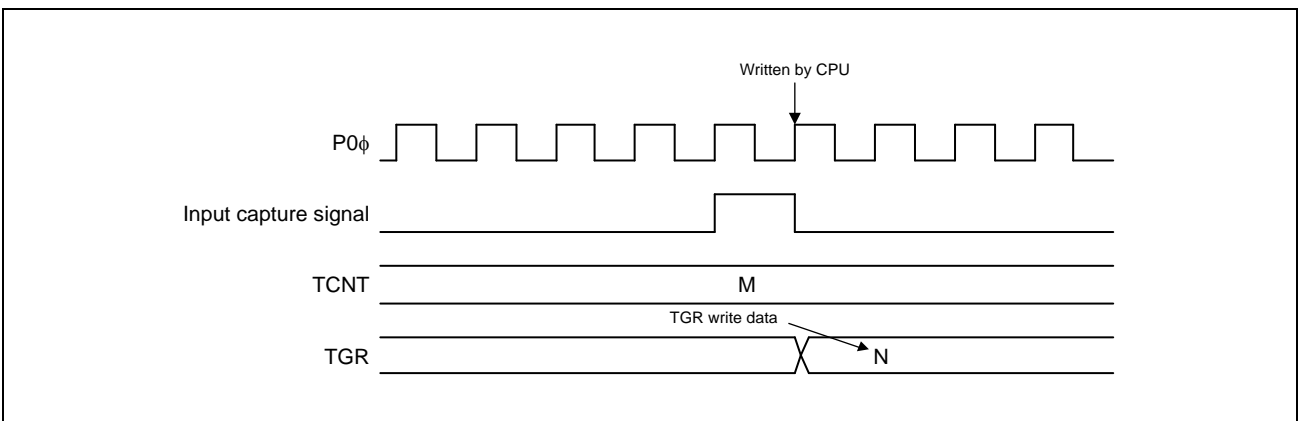

Figure 16.141 Contention between TGR Write Operation and Input Capture (MTU5)

16.6.10 Contention between Buffer Register Write Operation and Input Capture

If an input capture signal is generated in the buffer register write cycle, the buffer operation takes precedence and the buffer register write operation is not performed.

Figure 16.142 shows the timing in this case.

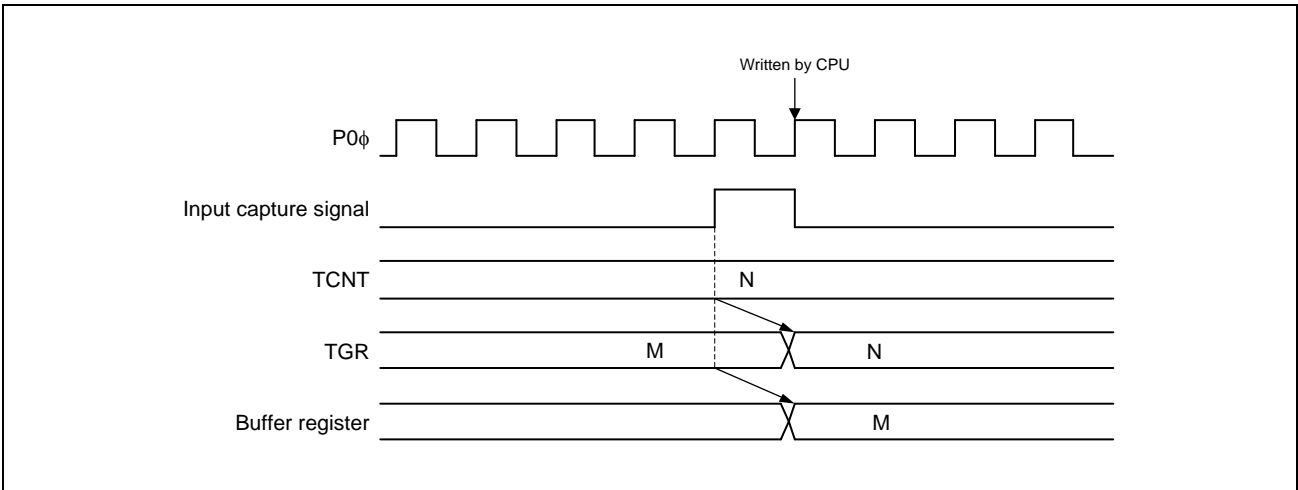

Figure 16.142 Contention between Buffer Register Write Operation and Input Capture

16.6.11 Contention between MTU2.TCNT Write Operation and Overflow/Underflow in Cascaded Operation

With timer counters TCNT in MTU1 and MTU2 cascaded, when a contention occurs between the counting by TCNT in MTU1 (a TCNT overflow/underflow in MTU2) and the writing to TCNT in MTU2, the TCNT write operation is performed in MTU2 and the TCNT count signal in MTU1 is disabled. In this case, if TGRA in MTU1 works as a compare match register and there is a match between the values of TGRA and TCNT in MTU1, a compare match signal is issued.

Furthermore, when the TCNT count clock in MTU1 is selected as the input capture source of MTU0, TGRA to TGRD in MTU0 work in input capture mode. In addition, when the TGRC compare match/input capture in MTU0 is selected as the input capture source of TGRB in MTU1, TGRB in MTU1 works in input capture mode.

Figure 16.143 shows the timing in this case.

When setting the TCNT clearing function in cascaded operation, be sure to synchronize MTU1 and MTU2.

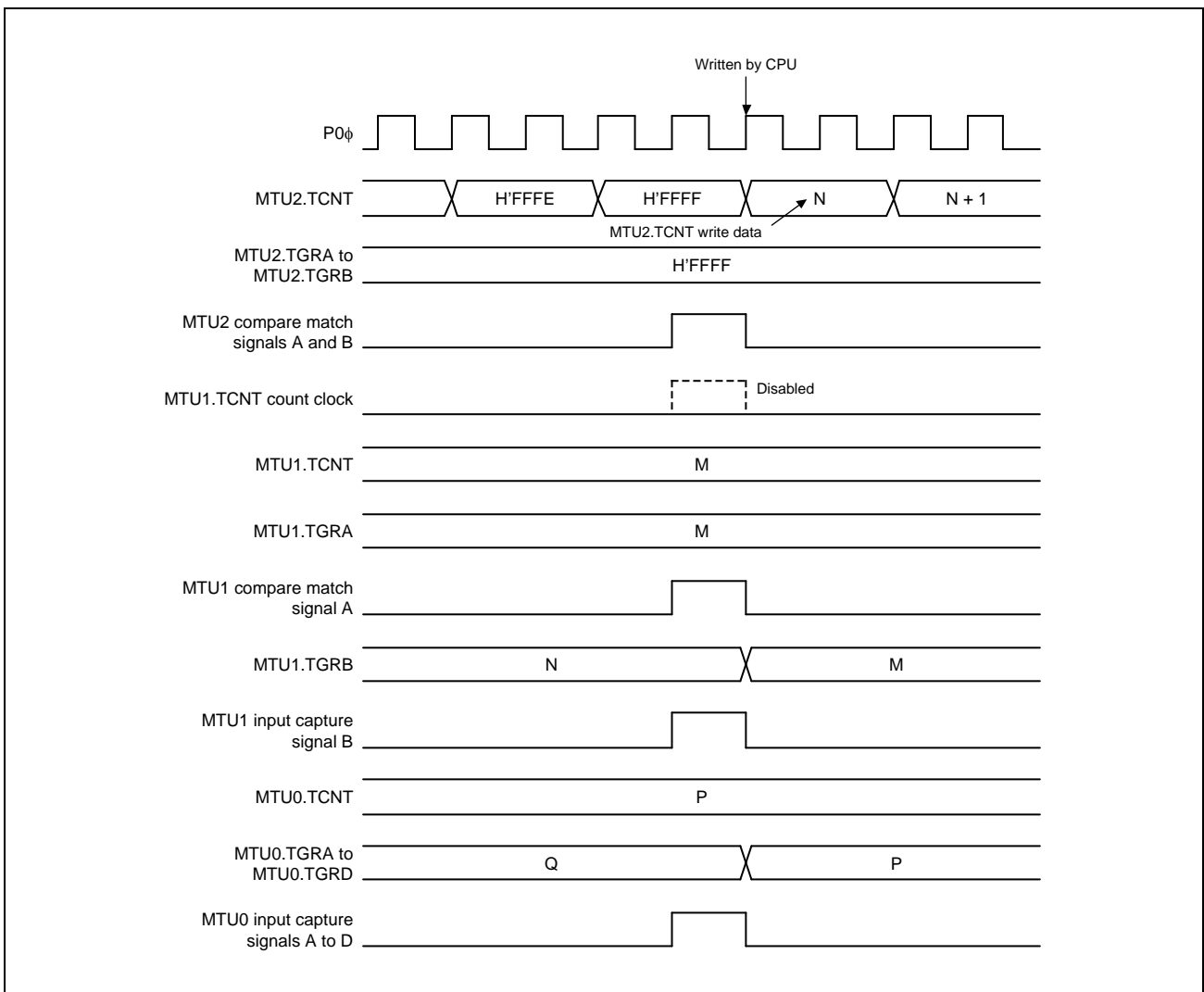

Figure 16.143 Contention between MTU2.TCNT Write Operation and Overflow/Underflow in Cascaded Operation

16.6.12 Counter Value When Count Operation is Stopped in Complementary PWM Mode

When counting operation in MTU3.TCNT and MTU4.TCNT (MTU6.TCNT and MTU7.TCNT) is stopped in complementary PWM mode, the MTU3.TCNT (MTU6.TCNT) value is set to the timer dead time register (TDDRA (TDDRb)) value and MTU4.TCNT (MTU7.TCNT) is set to H'0000.

When operation is restarted in complementary PWM mode, counting begins automatically from the initial setting state.

Figure 16.144 shows this operation.

When counting begins in another operating mode, be sure to make initial settings in MTU3.TCNT and MTU4.TCNT (MTU6.TCNT and MTU7.TCNT).

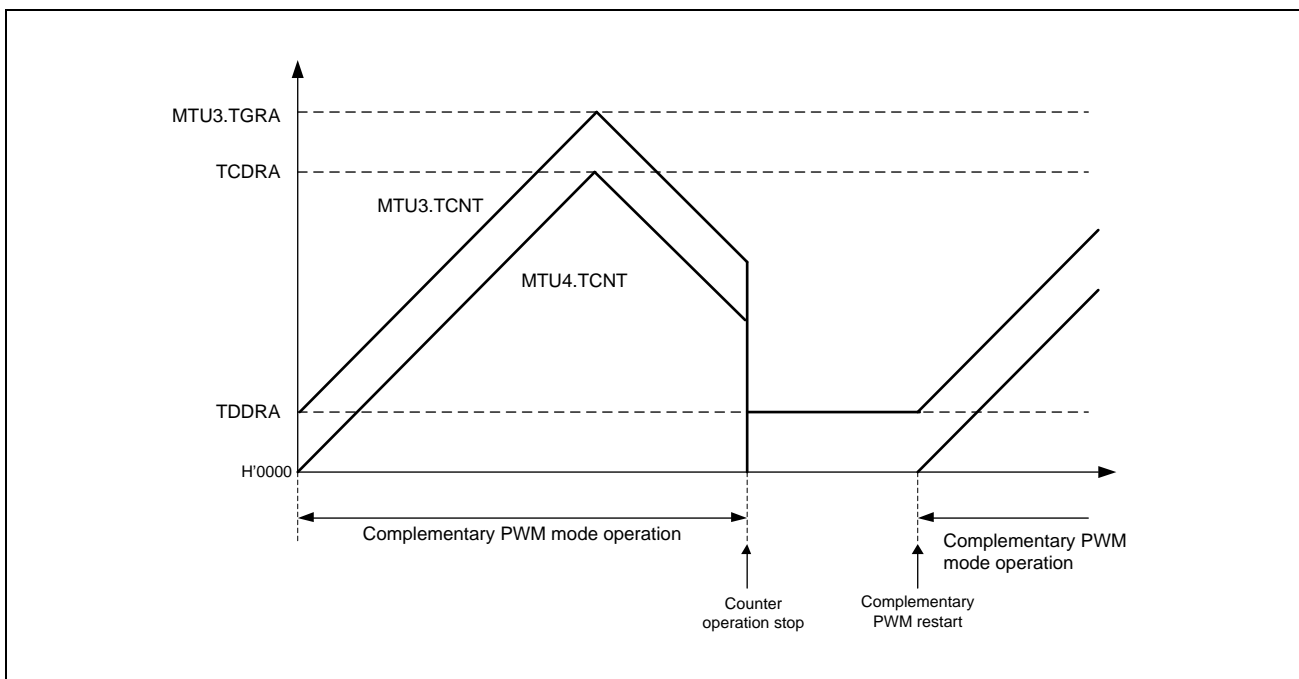

Figure 16.144 Counter Value When Stopped in Complementary PWM Mode

16.6.13 Buffer Operation Setting in Complementary PWM Mode

When modifying the PWM cycle set register (MTU3.TGRA or MTU6.TGRA), timer cycle data register (TCDRA or TCDRB), and duty set registers (MTU3.TGRB, MTU4.TGRA, and MTU4.TGRB (MTU6.TGRB, MTU7.TGRA, and MTU7.TGRB)) in complementary PWM mode, be sure to use buffer operation. In addition, set the BFA and BFB bits in MTU4.TMDR1 (MTU7.TMDR1) to 0. The MTIOC4C (MTIOC7C) pin cannot output waveforms if the BFA bit in MTU4.TMDR1 (MTU7.TMDR1) is set to 1. Likewise, the MTIOC4D (MTIOC7D) pin cannot output waveforms if the BFB bit in MTU4.TMDR1 (MTU7.TMDR1) is set to 1.

In complementary PWM mode, buffer operation in MTU3 and MTU4 (or MTU6 and MTU7) depends on the settings in bits BFA and BFB of MTU3.TMDR1 (MTU6.TMDR1). When the BFA bit in MTU3.TMDR1 (MTU6.TMDR1) is set to 1, MTU3.TGRC (MTU6.TGRC) functions as a buffer register for MTU3.TGRA (MTU6.TGRA). At the same time, MTU4.TGRC (MTU7.TGRC) functions as a buffer register for MTU4.TGRA (MTU7.TGRA), and TCBRA (TCBRB) functions as a buffer register for TCDRA (TCDRB).

16.6.14 Buffer Operation and Compare Match in Reset-Synchronized PWM Mode

When setting buffer operation in reset-synchronized PWM mode, set the BFA and BFB bits in MTU4.TMDR1 (MTU7.TMDR1) to 0. The MTIOC4C (MTIOC7C) pin cannot output waveforms if the BFA bit in MTU4.TMDR1 (MTU7.TMDR1) is set to 1. Likewise, the MTIOC4D (MTIOC7D) pin cannot output waveforms if the BFB bit in MTU4.TMDR1 (MTU7.TMDR1) is set to 1.

In reset-synchronized PWM mode, buffer operation in MTU3 and MTU4 (or MTU 6 and MTU7) depends on the settings in the BFA and BFB bits of MTU3.TMDR1 (MTU6.TMDR1). For example, if the BFA bit in MTU3.TMDR1 (MTU6.TMDR1) is set to 1, MTU3.TGRC (MTU6.TGRC) functions as a buffer register for MTU3.TGRA (MTU6.TGRA). At the same time, MTU4.TGRC (MTU7.TGRC) functions as a buffer register for MTU4.TGRA (MTU7.TGRA).

While the MTU3.TGRC (MTU6.TGRC) and MTU3.TGRD (MTU6.TGRD) are operating as buffer registers, a TGImm interrupt (m = C or D; n = 3, 4, 6, or 7) is not generated.

Figure 16.145 shows an example of MTU3.TGR (MTU6.TGR), MTU4.TGR (MTU7.TGR), MTIOC3 (MTIOC6), and MTIOC4 (MTIOC7) operation with the BFA and BFB bits in MTU3.TMDR1 (MTU6.TMDR1) set to 1 and the BFA and BFB bits in MTU4.TMDR1 (MTU7.TMDR1) set to 0.

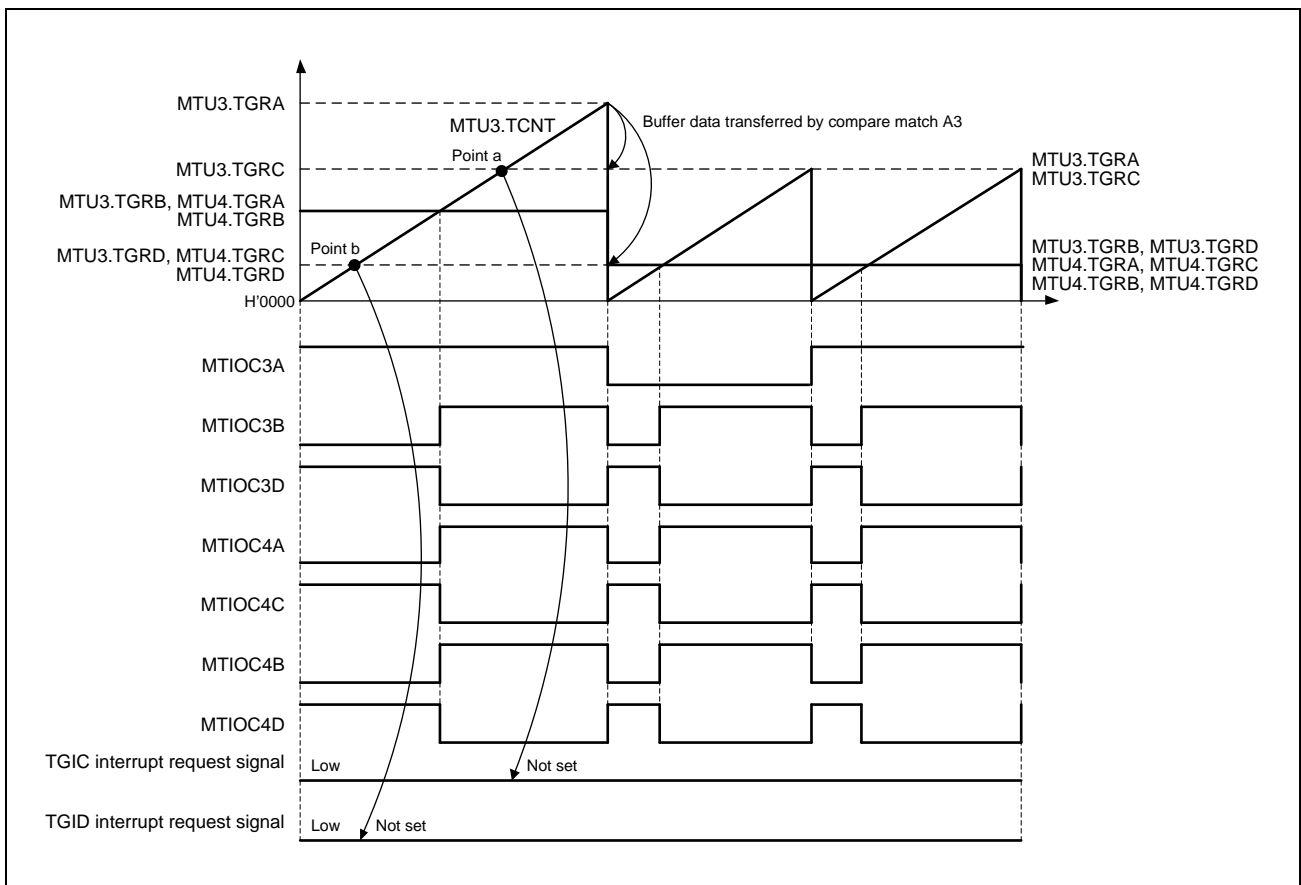

Figure 16.145 Buffer Operation and Compare Match in Reset-Synchronized PWM Mode

16.6.15 Overflow in Reset-Synchronized PWM Mode

After reset-synchronized PWM mode is selected, the TCNT counters in MTU3 and MTU4 (MTU6 and MTU7) start counting when the CST3 (CST6) bit of TSTRA (TSTRB) is set to 1. In this state, the TCNT count clock source and count edge in MTU4 (MTU7) are determined by the setting of TCR in MTU3 (MTU6).

In reset-synchronized PWM mode, with cycle register TGRA in MTU3 (MTU6) set to H'FFFF and the TGRA compare match in MTU3 (MTU6) selected as the counter clearing source, the TCNT counters in MTU3 and MTU4 (MTU6 and MTU7) count up to H'FFFF, then a compare match occurs with TGRA in MTU3 (MTU6), and the TCNT counters in MTU3 and MTU4 (MTU6 and MTU7) are both cleared. In this case, a TCIVn interrupt (n = 3, 4, 6, or 7) is not generated.

Figure 16.146 shows an example of the operation in reset-synchronized PWM mode with cycle register TGRA in MTU3 (MTU6) set to H'FFFF and the TGRA compare match in MTU3 (MTU6) specified for the counter clearing source.

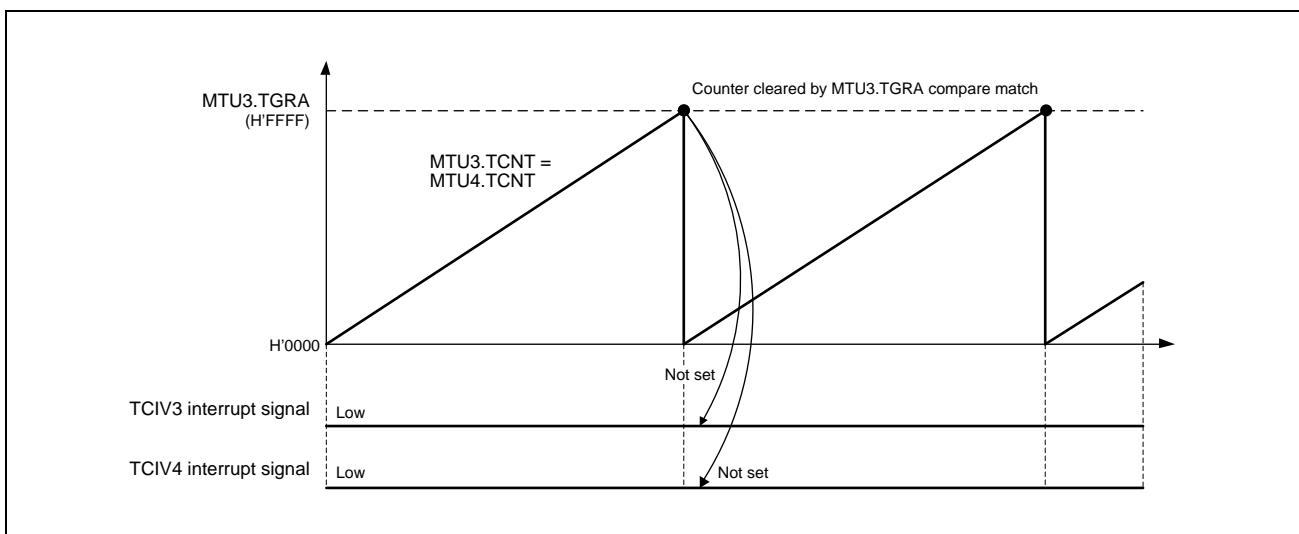

Figure 16.146 Overflow in Reset-Synchronized PWM Mode

16.6.16 Contention between Overflow/Underflow and Counter Clearing

If an overflow/underflow and counter clearing occur simultaneously, a TCIVn interrupt ($n = 0$ to 4 or 6 to 8) nor a TCIUn interrupt ($n = 1$ or 2) is not generated and TCNT clearing takes precedence.

Figure 16.147 shows the operation timing when a TGR compare match is specified as the clearing source and TGR is set to H'FFFF.

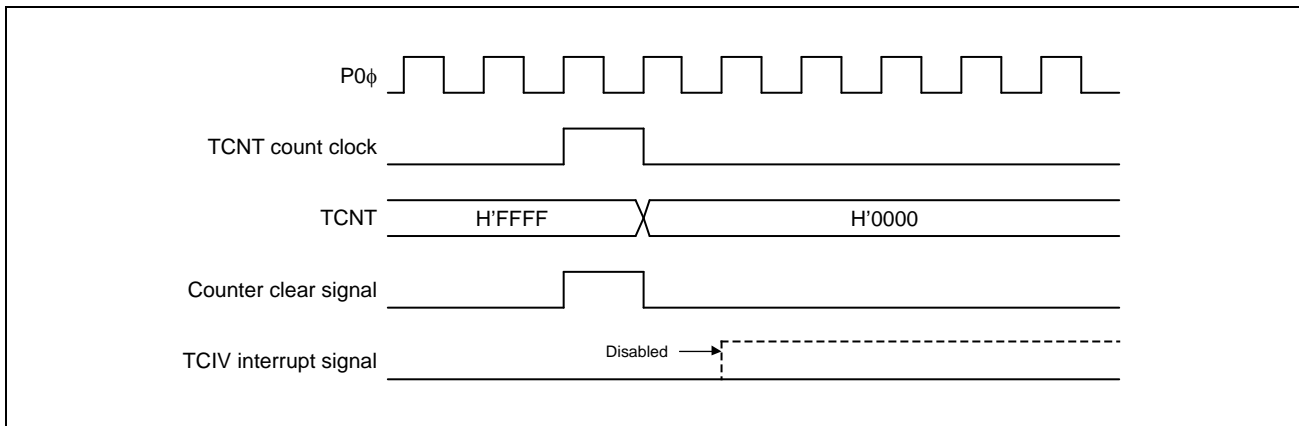

Figure 16.147 Contention between Overflow and Counter Clearing

16.6.17 Contention between TCNT Write Operation and Overflow/Underflow

If TCNT counts up or down in a TCNT write cycle and an overflow or an underflow occurs, the TCNT write operation takes precedence. A TCIVn interrupt ($n = 0$ to 4 or 6 to 8) nor a TCIUn interrupt ($n = 1$ or 2) is not generated.

Figure 16.148 shows the operation timing when there is contention between TCNT write operation and overflow.

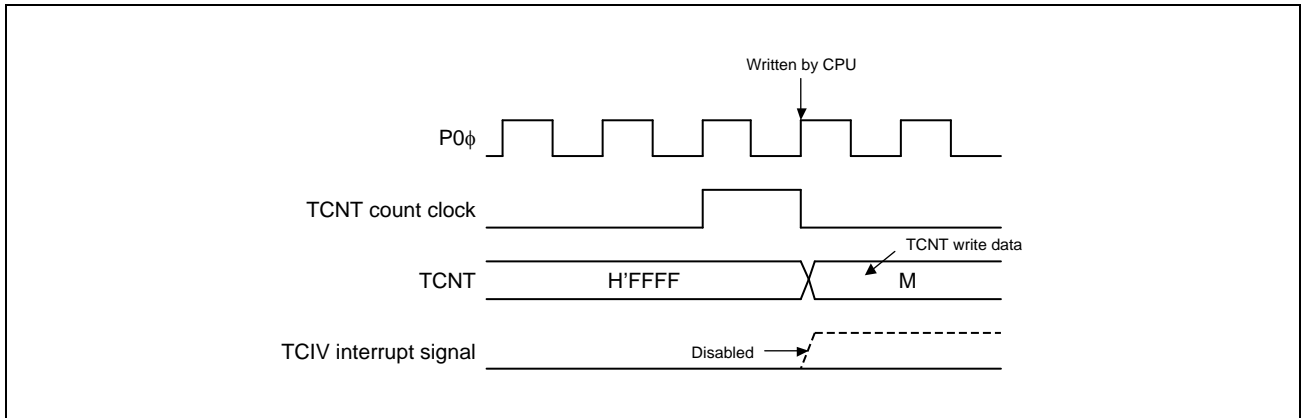

Figure 16.148 Contention between TCNT Write Operation and Overflow

16.6.18 Note on Transition from Normal Mode or PWM Mode 1 to Reset-Synchronized PWM Mode

When making a transition from normal mode or PWM mode 1 to reset-synchronized PWM mode in MTU3 and MTU4 (or MTU6 and MTU7), if the counter is stopped while the output pins (MTIOC3B, MTIOC3D, MTIOC4A, MTIOC4C, MTIOC4B, MTIOC4D, MTIOC6B, MTIOC6D, MTIOC7A, MTIOC7C, MTIOC7B, and MTIOC7D) are held at a high level and then operation is started after a transition to reset-synchronized PWM mode, the initial pin output will not be correct.

When making a transition from normal mode to reset-synchronized PWM mode, write H'11 to MTU3.TIORH, MTU3.TIORL, MTU4.TIORH, and MTU4.TIORL (MTU6.TIORH, MTU6.TIORL, MTU7.TIORH, and MTU7.TIORL) to initialize the output pin state to a low level, then set the registers to the initial value (H'00) before making the mode transition.

When making a transition from PWM mode 1 to reset-synchronized PWM mode, switch to normal mode, initialize the output pin state to a low level, and then set the registers to the initial value (H'00) before making the transition to reset-synchronized PWM mode.

16.6.19 Output Level in Complementary PWM Mode and Reset-Synchronized PWM Mode

When MTU3 and MTU4 (or MTU6 and MTU7) are in complementary PWM mode or reset-synchronized PWM mode, the PWM waveform output level is determined by the OLSP and OLSN bits in the timer output control register (TOCR1A or TOCR1B). In complementary PWM mode or reset-synchronized PWM mode, TIOR should be set to H'00. The output level in negative phase when the TDER bit in TDERA (TDERB) is set to 0 in complementary PWM mode (the dead time is not generated) does not depend on the setting of the OLSN bit in TOCR1A (TOCR1B). It is equivalent to the inverted level of positive phase output based on the setting of the OLSP bit in TOCR1A (TOCR1B).

16.6.20 Simultaneous Input Capture in MTU1.TCNT and MTU2.TCNT in Cascade Connection

When timer counters 1 and 2 (MTU1.TCNT and MTU2.TCNT) operate as a 32-bit counter in cascade connection, the cascaded counter value cannot be captured successfully in some cases even if input-capture input is simultaneously done to MTIOC1A and MTIOC2A or to MTIOC1B and MTIOC2B. This is because the input timing of MTIOC1A and MTIOC2A or to MTIOC1B and MTIOC2B may not be the same when external input-capture signals input into MTU1.TCNT and MTU2.TCNT are taken in synchronization with the internal clock.

For example, MTU1.TCNT (the counter for upper 16 bits) does not capture the count-up value by an overflow from MTU2.TCNT (the counter for lower 16 bits) but captures the count value before the up-counting. In this case, the values of MTU1.TCNT = H'FFF1 and MTU2.TCNT = H'0000 should be transferred to MTU1.TGRA and MTU2.TGRA or to MTU1.TGRB and MTU2.TGRB, but the values of MTU1.TCNT = H'FFF0 and MTU2.TCNT = H'0000 are erroneously transferred.

The MTU has a function that allows simultaneous capture of MTU1.TCNT and MTU2.TCNT with a single input capture input. This function can be used to read the 32-bit counter such that MTU1.TCNT and MTU2.TCNT are captured at the same time. For details, see **Section 16.2.11, Timer Input Capture Control Register (TICCR)**.

16.6.21 Interrupt-Skipping Function 2

When interrupt-skipping function 2 is in use and the difference between the values in MTU4.TADCORA and MTU4.TADCORB is small, correct counting of the number skipped may not be possible, in which case requests for A/D conversion will not be generated with the expected timing. The conditions listed below thus apply to these settings.

For MTU6 and MTU7, the same conditions apply to the settings of MTU7.TADCORA and MTU7.TADCORB.

(1) When the number skipped is zero for skipping function 2

- The difference between the values in MTU4.TADCORA and MTU4.TADCORB must be at least four.
- The interval of comparison for MTU4.TADCORA must be at least four cycles of P0φ clock (the updated value of MTU4.TADCORA is set to the previous value plus or minus at least four).
- The interval of comparison for MTU4.TADCORB must be at least four cycles of P0φ clock (the updated value of MTU4.TADCORB is set to the previous value plus or minus at least four).

(2) When the number skipped is one or more for skipping function 2

- The difference between the values in MTU4.TADCORA and MTU4.TADCORB must be at least two.
- The interval of comparison for MTU4.TADCORB must be at least two cycles of P0φ (the updated value of MTU4.TADCORB is set to the previous value plus or minus at least two).

16.6.22 Notes When Complementary PWM Mode Output Protection Function is Not Used

The complementary PWM mode output protection function is initially enabled. For details, refer to **Section 17, Port Output Enable 3 (POE3)**.

16.6.23 Notes Regarding Timer Counter (MTU5.TCNT) and Timer General Register (MTU5.TGR)

Do not set TGR_j (j = U, V, or W) in MTU5 to the value of the corresponding TCNT_j in MTU5 plus one while counting by TCNT_j in MTU5 is stopped. If such a setting is made, a compare match will be generated even though counting is stopped.

In this case, if the value of the compare match enable bit (TGIE5_j bit of TIER in MTU5) is 1 (enabled), a compare match interrupt will also be generated. If the value of the timer compare match clear register is 1 (enabled), the TCNT_j counter in MTU5 is automatically cleared to H'0000 when the compare match is generated, regardless of whether compare match interrupts are enabled or disabled.

16.6.24 Notes to Prevent Malfunctions in Synchronous Clearing for Complementary PWM Mode

If control of the output waveform is enabled (the WRE bit of TWCRA or TWCRB is 1) at the time of synchronous counter clearing in complementary PWM mode, satisfaction of either condition 1 or 2 below has the following effects.

- Dead time on the PWM output pins is shortened (or disappears).
- The active level is output on the negative phase PWM output pins beyond the period for active-level output.

Condition 1:

In portion (10) of the initial output inhibition period in **Figure 16.149**, synchronous clearing occurs within the dead-time period for PWM output.

Condition 2:

In portions (10) and (11) of the initial output inhibition period in **Figure 16.150**, synchronous clearing occurs when any condition from among TGRB in MTU3 ($MTU6 \leq TDDR$), TGRA in MTU4 ($MTU7 \leq TDDR$), and TGRB in MTU4 ($MTU7 \leq TDDR$) is satisfied.

The following method avoids the above phenomena.

Ensure that synchronous clearing proceeds with the value of each comparison register (TGRB in MTU3 (MTU6), TGRA in MTU4 (MTU7), and TGRB in MTU4 (MTU7)) set to at least double the value of the TDDRA register (TDDR register).

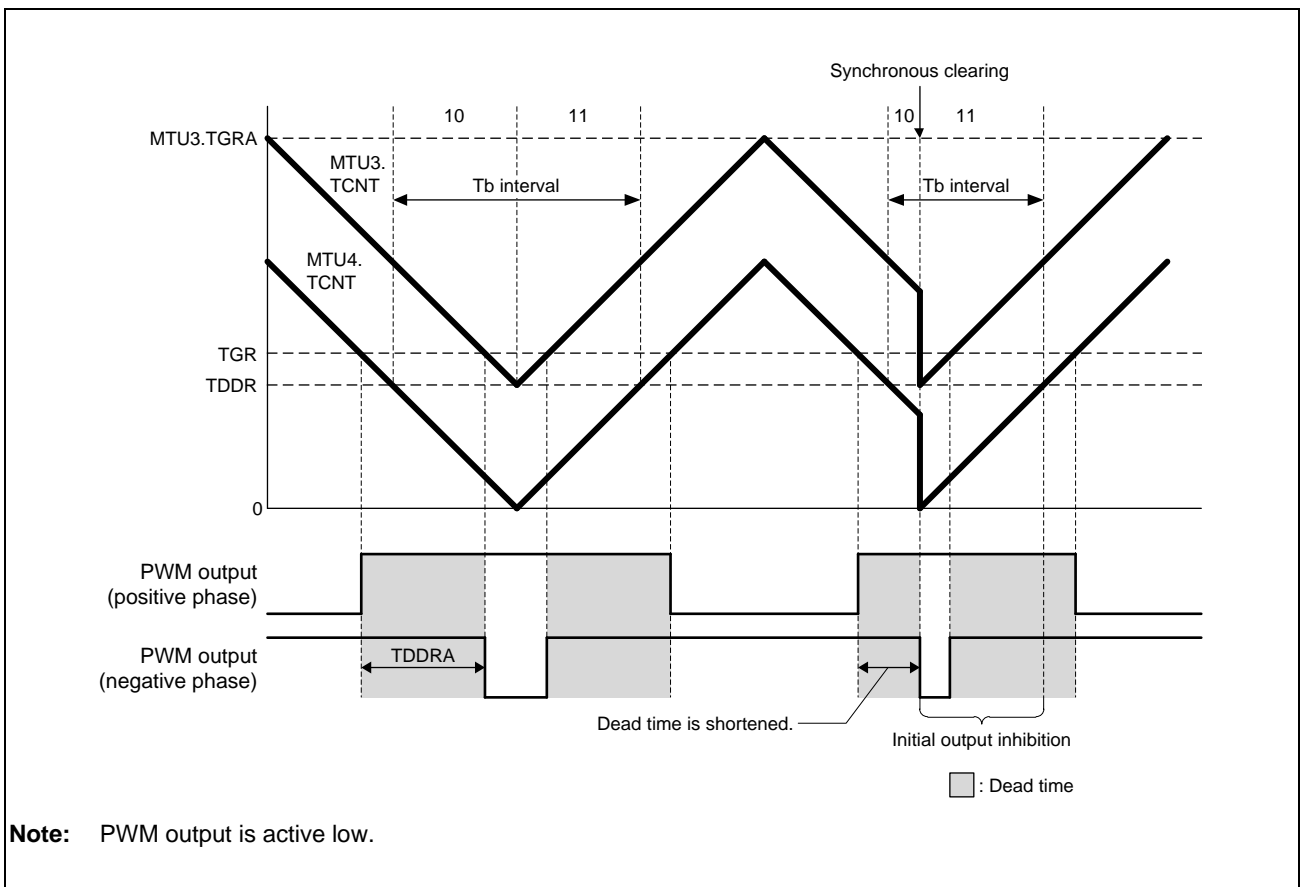

Figure 16.149 Example of Synchronous Clearing (When Condition 1 Applies)

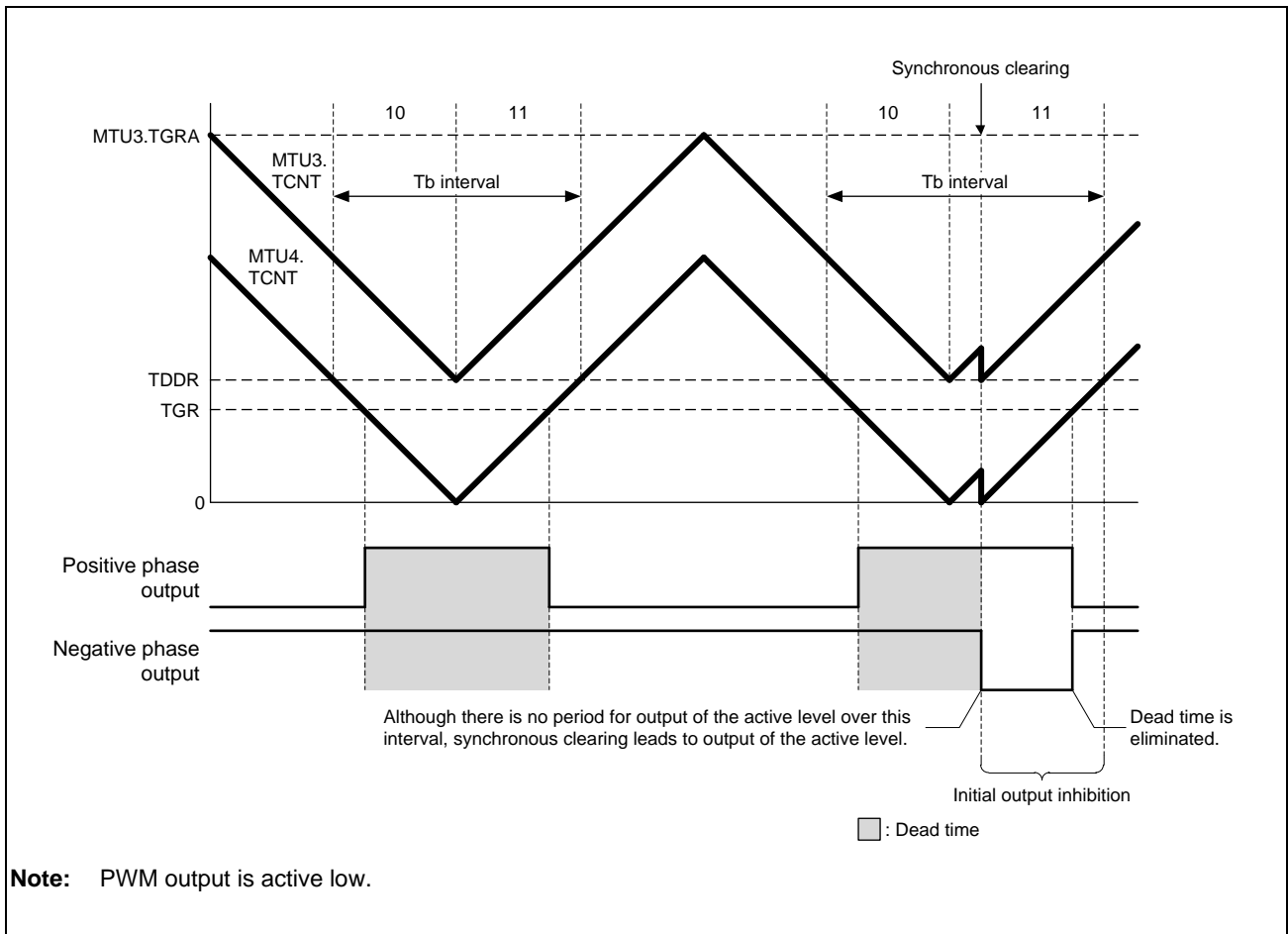

Figure 16.150 Example of Synchronous Clearing (When Condition 2 Applies)

16.6.25 Continuous Output of Interrupt Signal in Response to a Compare Match

When the TGR register is set to H'0000, the P0 ϕ /1 clock is set as the count clock, and compare match is set as the trigger for clearing of the count clock, the value of the TCNT counter remains H'0000, and the interrupt signal will be output continuously (i.e. its level will be flat) rather than output over a single cycle. Consequently, interrupts will not be detected in response to second and subsequent compare matches.

Figure 16.151 shows the timing for continuous output of the interrupt signal in response to a compare match.

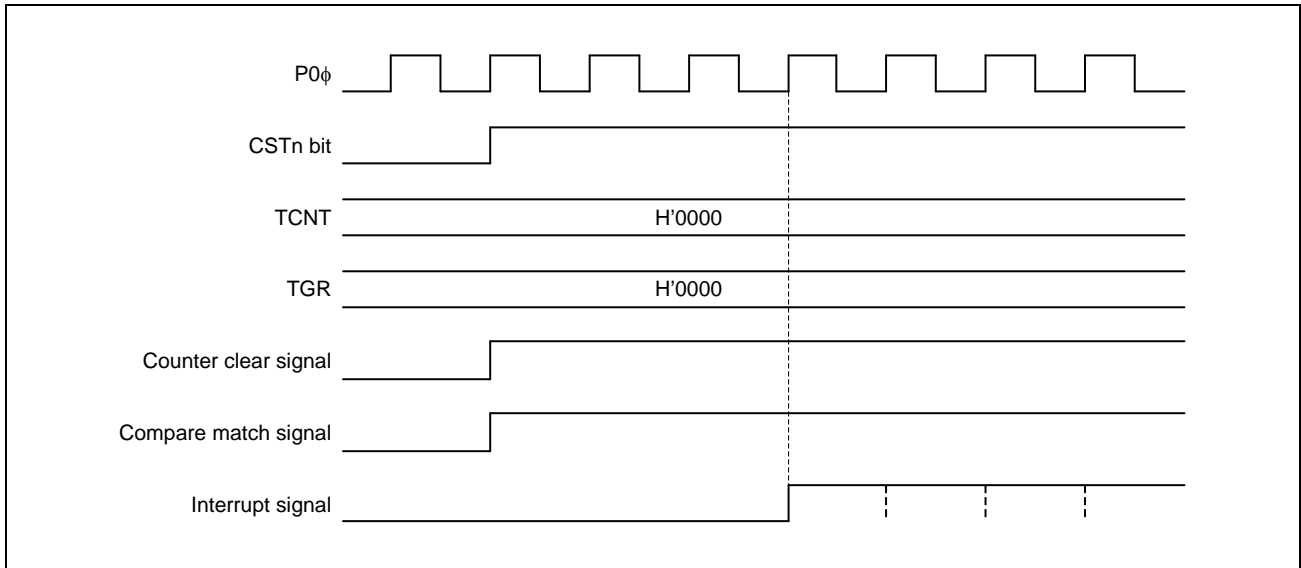

Figure 16.151 Continuous Output of Interrupt Signal in Response to a Compare Match

16.6.26 Notes on A/D Converter Start Request Delaying Function in Complementary PWM Mode

- When the TADCOBRA or TADCOBRB register in MTU4 (MTU7) is set to 0, the UT4AE or UT4BE (UT7AE or UT7BE) bit of TADCR in MTU4 (MTU7) is set to 1, and buffer transfer is performed at the trough of the value of the TCNT counter in MTU4 (MTU7), an A/D converter start request is not issued during up-counting immediately after the transfer (**Figure 16.152**).
- When the TADCOBRA or TADCOBRB register in MTU4 (MTU7) is set to the same value as that in the TCDR register, the DT4AE or DT4BE (DT7AE or DT7BE) bit of TADCR in MTU4 (MTU7) is set to 1, and buffer transfer is performed at the crest of the value of the TCNT counter in MTU4 (MTU7), an A/D converter start request is not issued during down-counting immediately after the transfer (**Figure 16.153**).
- When using A/D converter start requests in coordination with the interrupt skipping function, set up the TADCORA or TADCORB register in MTU4 (MTU7) so that the setting satisfies the condition " $2 \leq \text{TADCORA or TADCORB in MTU}_n \leq \text{TCDR} - 2$ " ($n = 4 \text{ or } 7$).

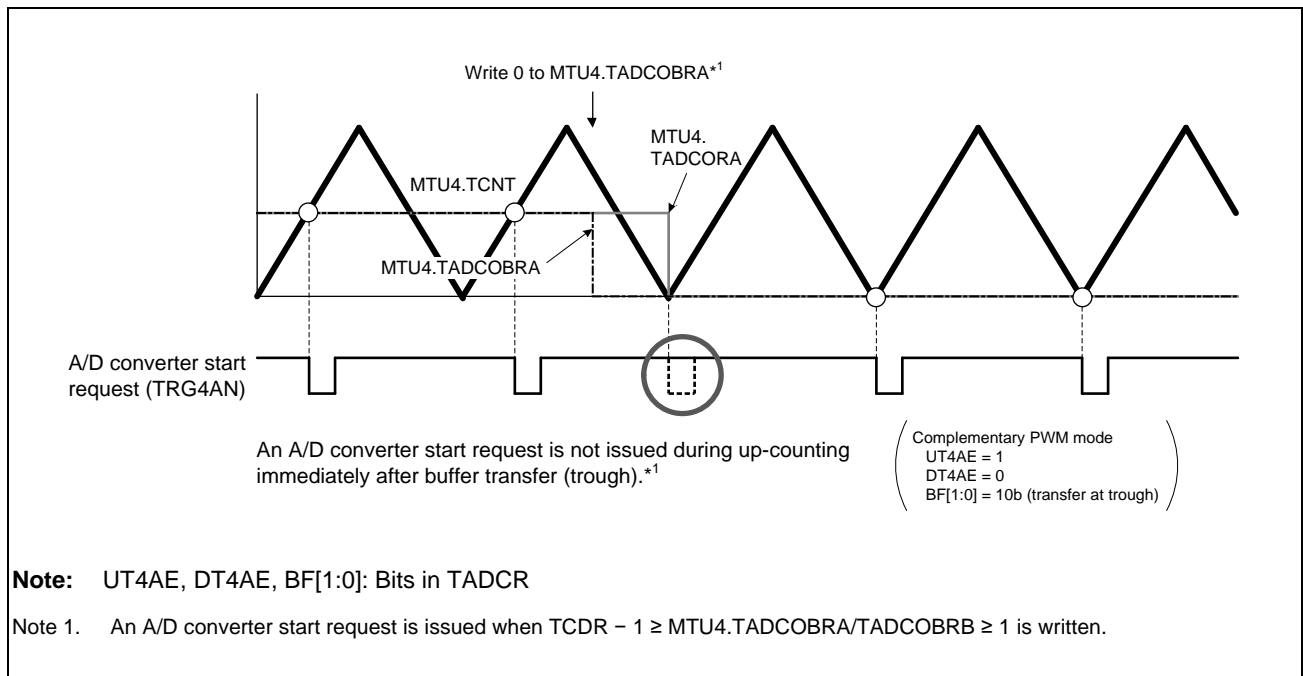

Figure 16.152 A/D Converter Start Request when TADCOBRA is Set to 0 in MTU4

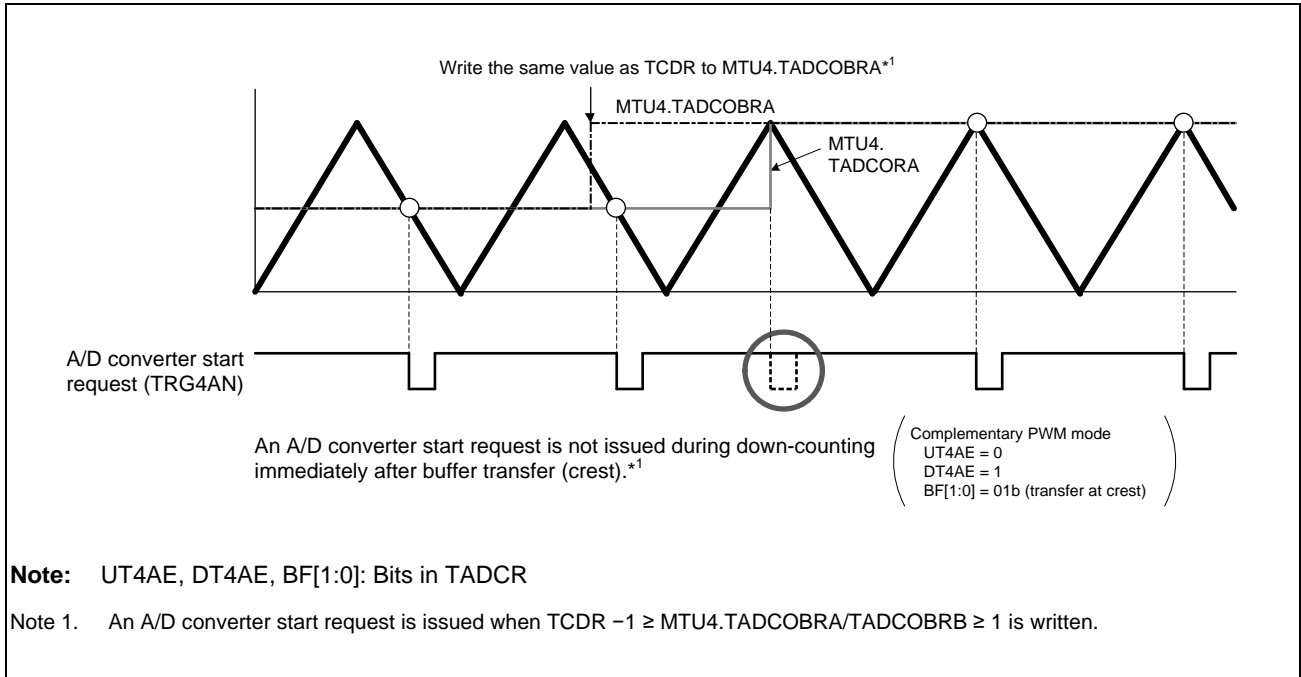

Figure 16.153 A/D Converter Start Request when TADCOBRA is Set to the Same Value as TCDR in MTU4

16.7 MTU Output Pin Initialization

16.7.1 Operating Modes

The MTU has the following six operating modes. Waveforms can be output in any of these modes.

- Normal mode (MTU0 to MTU4 and MTU6 to MTU8)
- PWM mode 1 (MTU0 to MTU4, MTU6, and MTU7)
- PWM mode 2 (MTU0 to MTU2)
- Phase counting modes 1 to 5 (MTU1 and MTU2)
- Complementary PWM mode (MTU3, MTU4, MTU6, and MTU7)
- Reset-synchronized PWM mode (MTU3, MTU4, MTU6, and MTU7)

This section describes how to initialize the MTU output pins in each of these modes.

16.7.2 Operation in Case of Re-Setting Due to Error during Operation

If an error occurs during MTU operation, MTU output should be cut off by the system. The output can be cut off by allowing non-active level output from the pins by setting the pins as general output ports using the port mode registers (PMn), port registers (Pn), and port mode control registers (PMcn) of the I/O ports. MTU output can be disabled through TIOR settings. Complementary PWM output (MTIOC3B, MTIOC3D, MTIOC4A, MTIOC4B, MTIOC4C, MTIOC4D, MTIOC6B, MTIOC6D, MTIOC7A, MTIOC7B, MTIOC7C, and MTIOC7D) should be specified through TOERA and TOERB settings. For PWM output pins, output can also be cut by hardware, using port output enable 3 (POE3). The pin initialization procedures for re-setting due to an error during operation and the procedures for restarting in a different mode after re-setting are described below.

The MTU has six operating modes, as stated above. There are thus 36 mode transition combinations, but some transitions are not available with certain channel and mode combinations. Available mode transition combinations are shown in **Table 16.80**.

Table 16.80 Mode Transition Combinations

	Normal	PWM1	PWM2	PCM	CPWM	RPWM
Normal	(1)	(2)	(3)	(4)	(5)	(6)
PWM1	(7)	(8)	(9)	(10)	(11)	(12)
PWM2	(13)	(14)	(15)	(16)	Not available	Not available
PCM	(17)	(18)	(19)	(20)	Not available	Not available
CPWM	(21)	(22)	Not available	Not available	(23) (24)	(25)
RPWM	(26)	(27)	Not available	Not available	(28)	(29)

Note: Normal: Normal mode
 PWM1: PWM mode 1
 PWM2: PWM mode 2
 PCM: Phase counting modes 1 to 5
 CPWM: Complementary PWM mode
 RPWM: Reset-synchronized PWM mode

16.7.3 Overview of Initialization Procedures and Mode Transitions in Case of Error during Operation

- When making a transition to a mode (Normal, PWM1, PWM2, or PCM) in which the pin output level is selected by the timer I/O control register (TIOR) setting, initialize the pins by means of TIOR setting.
- In PWM mode 1, waveforms are not output to the MTIOCnB and MTIOCnD pins ($n = 3, 4, 6, \text{ or } 7$). If the MTIOCnB or MTIOCnD output is selected as the function of the pins, they enter high-impedance state. To output a specified level, make necessary settings for general output ports in the port mode registers (PMn), port registers (Pn), and port mode control registers (PMCn) of the I/O ports.
- In PWM mode 2, waveforms are not output to the pins corresponding to the TGR registers used as cycle registers. If the MTIOCnm output ($n = 0 \text{ to } 2$ and $m = A \text{ to } D$) is selected as the function of the pins, they enter high-impedance state. To output a specified level, make necessary settings for general output ports in the port mode registers (PMn), port registers (Pn), and port mode control registers (PMCn) of the I/O ports.
- In normal mode or PWM mode 2, if TGRC and TGRD operate as buffer registers, waveforms are not output to the corresponding MTIOCnC and MTIOCnD pins ($n = 0, 3, 4, 6, \text{ or } 7$). If the MTIOCnC or MTIOCnD output is selected as the function of the pins, they enter high-impedance state. To output a specified level, make necessary settings for general output ports in the port mode registers (PMn), port registers (Pn), and port mode control registers (PMCn) of the I/O ports.
- In PWM mode 1, if either TGRC or TGRD operates as a buffer register, waveforms are not output to the corresponding MTIOCnC and MTIOCnD pins ($n = 0, 3, 4, 6, \text{ or } 7$). If the MTIOCnC or MTIOCnD output is selected as the function of the pins, they enter high-impedance state. To output a specified level, make necessary settings for general output ports in the port mode registers (PMn), port registers (Pn), and port mode control registers (PMCn) of the I/O ports.
- When making a transition to a mode (CPWM or RPWM) in which the pin output level is selected by the timer output control register (TOCR1A, TOCR2A, TOCR1B, or TOCR2B) setting, temporarily disable output in MTU3 and MTU4 (or MTU6 and MTU7) with the timer output master enable register (TOERA or TOERB). If the MTIOCnm output ($n = 3, 4, 6, \text{ or } 7$ and $m = A \text{ to } D$) is selected as the function of pins, they enter high-impedance state. To output a specified level, make necessary settings for general output ports in the port mode registers (PMn), port registers (Pn), and port mode control registers (PMCn) of the I/O ports. Switch to normal mode, perform initialization with TIOR, restore TIOR to its initial value, then operate the MTU in accordance with the mode setting procedure (TOCR1A setting, TOCR2A setting, TMDR1 setting, and TOERA setting (TOCR1B setting, TOCR2B setting, TMDR1 setting, and TOERB setting)).

NOTE

Channel number is substituted for “n” indicated in this section.

Pin initialization procedures are described below for the numbered combinations in **Table 16.80**. The active level is assumed to be low.

(1) Operation When Error Occurs in Normal Mode and Operation is Restarted in Normal Mode

Figure 16.154 shows a case in which an error occurs in normal mode and operation is restarted in normal mode after re- setting.

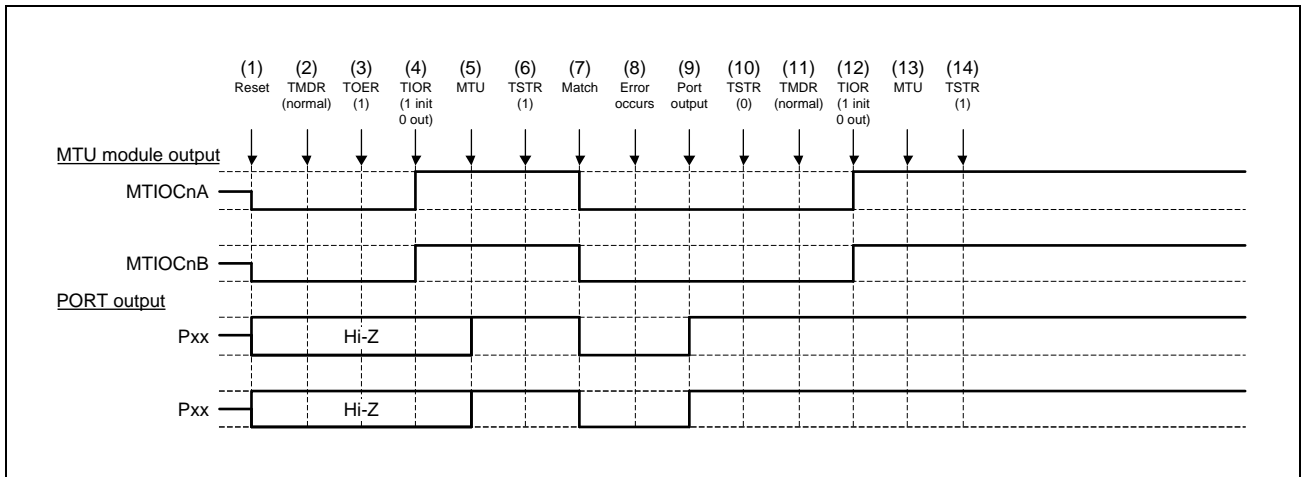

Figure 16.154 Error Occurrence in Normal Mode, Recovery in Normal Mode

- (1) After a reset, the MTU output goes low and the ports enter high-impedance state.
- (2) After a reset, the TMDR1 setting is for normal mode.
- (3) For MTU3 and MTU4 (MTU6 and MTU7), enable output with TOERA (TOERB) before initializing the pins with TIOR.
- (4) Initialize the pins with TIOR. (In the example, the initial output is a high level, and a low level is output on compare match occurrence.)
- (5) Set MTU output using the port mode control registers (PMCn) and port function control registers (PFCm) corresponding to the GPIO ports.
- (6) Start count operation by setting TSTRA (TSTRB).
- (7) Output goes low on compare match occurrence.
- (8) An error occurs.
- (9) Allow non-active level output by setting the pins as general output ports using the port mode registers (PMn), port registers (Pn), and port mode control registers (PMCn) of the I/O ports.
- (10) Stop count operation by setting TSTRA (TSTRB).
- (11) This step is not necessary when restarting in normal mode.
- (12) Initialize the pins with TIOR.
- (13) Set MTU output using the port mode control registers (PMCn) and Port function control registers (PFCm) corresponding to the GPIO ports.
- (14) Restart operation by setting TSTRA (TSTRB).

(2) Operation When Error Occurs in Normal Mode and Operation is Restarted in PWM Mode 1

Figure 16.155 shows a case in which an error occurs in normal mode and operation is restarted in PWM mode 1 after re-setting.

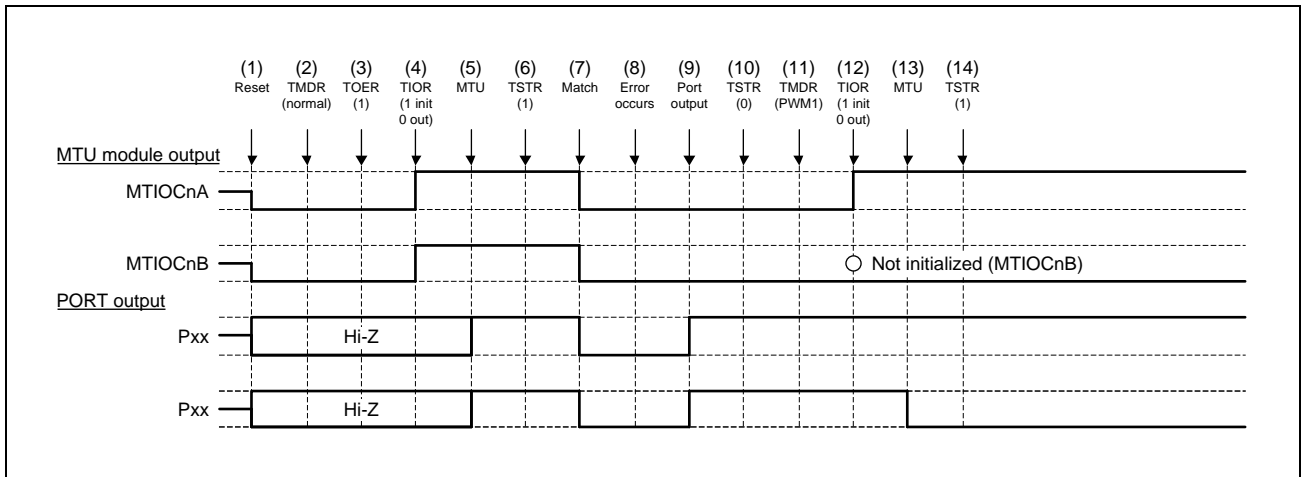

Figure 16.155 Error Occurrence in Normal Mode, Recovery in PWM Mode 1

(1) to (10) are the same as in **Figure 16.154**.

(11) Set PWM mode 1.

(12) Initialize the pins with TIOR. (In PWM mode 1, waveforms are not output to the MTIOCnB (MTIOCnD) pins. To output a specified level, make necessary settings for general output ports in the port mode registers (PMn) and port registers (Pn) of the I/O ports.)

(13) Set MTU output using the port mode control registers (PMcn) and Port function control registers (PFCm) corresponding to the GPIO ports.

(14) Restart operation by setting TSTRA (TSTRB).

(3) Operation When Error Occurs in Normal Mode and Operation is Restarted in PWM mode 2

Figure 16.156 shows a case in which an error occurs in normal mode and operation is restarted in PWM mode 2 after re-setting.

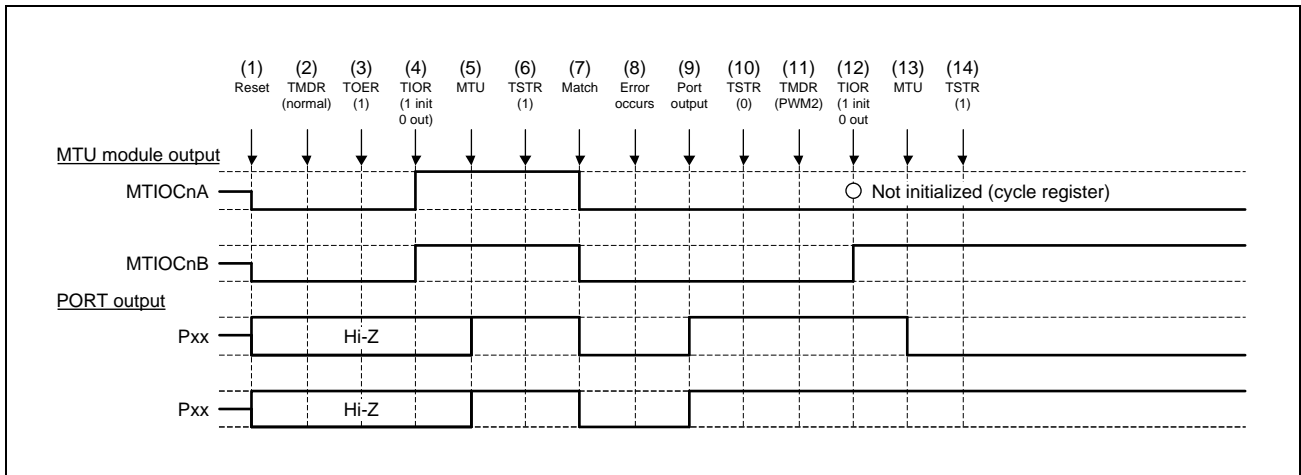

Figure 16.156 Error Occurrence in Normal Mode, Recovery in PWM Mode 2

(1) to (10) are the same as in **Figure 16.154**.

(11) Set PWM mode 2.

(12) Initialize the pins with TIOR. (In PWM mode 2, waveforms are not output to the pins corresponding to the TGR registers used as cycle registers. To output a specified level, set up the general output ports with the port mode registers (PMn) and port registers (Pn) of the I/O ports.)

(13) Set MTU output using the port mode control registers (PMcN) and Port function control registers (PFCm) corresponding to the GPIO ports.

(14) Restart operation by setting TSTR.

NOTE

PWM mode 2 can only be selected for MTU0 to MTU2, and therefore TOERA setting is not necessary.

(4) Operation When Error Occurs in Normal Mode and Operation is Restarted in Phase Counting Mode

Figure 16.157 shows a case in which an error occurs in normal mode and operation is restarted in phase counting mode after re-setting.

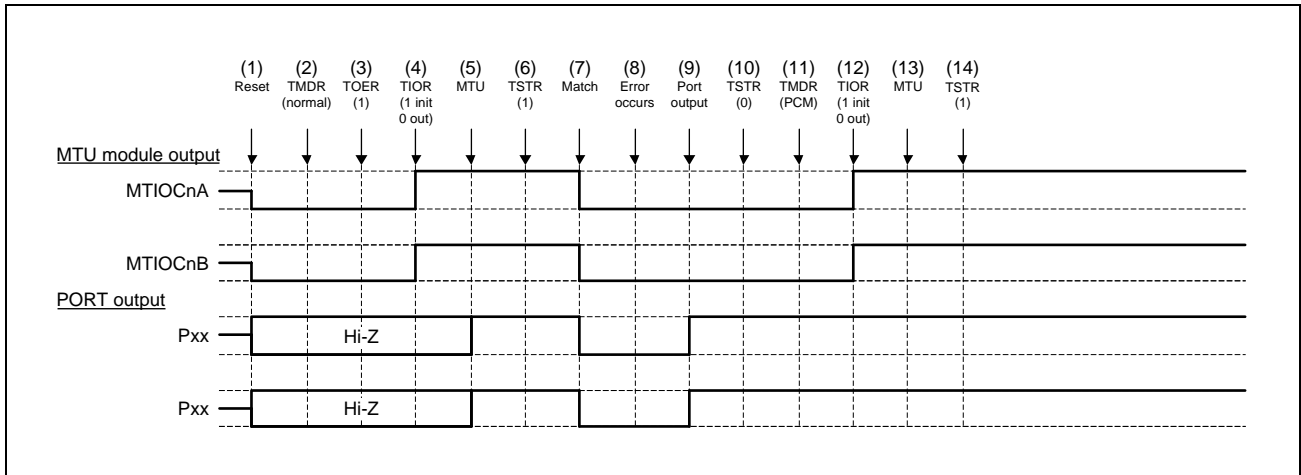

Figure 16.157 Error Occurrence in Normal Mode, Recovery in Phase Counting Mode

(1) to (10) are the same as in **Figure 16.154**.

(11) Set the phase counting mode.

(12) Initialize the pins with TIOR.

(13) Set MTU output using the port mode control registers (PMCn) and Port function control registers (PFCm) corresponding to the GPIO ports.

(14) Restart operation by setting TSTR.

NOTE

The phase counting mode can only be selected for MTU1 and MTU2, and therefore TOERA setting is not necessary.

(5) Operation When Error Occurs in Normal Mode and Operation is Restarted in Complementary PWM Mode

Figure 16.158 shows a case in which an error occurs in normal mode and operation is restarted in complementary PWM mode after re-setting.

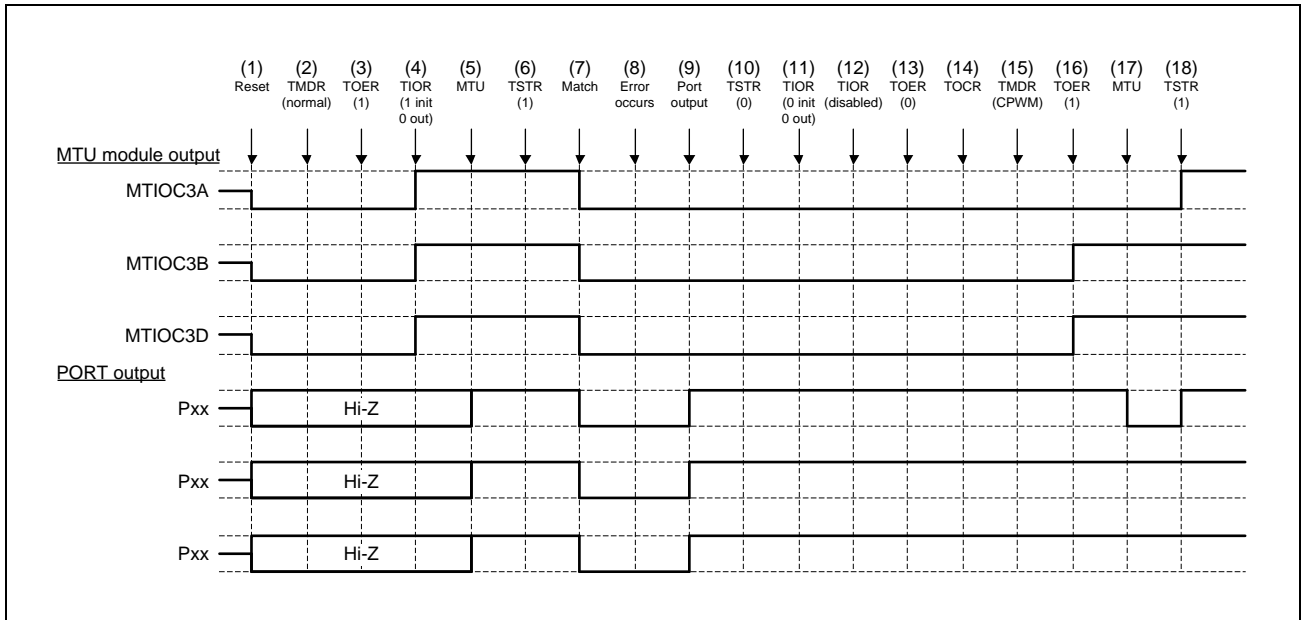

Figure 16.158 Error Occurrence in Normal Mode, Recovery in Complementary PWM Mode

(1) to (10) are the same as in **Figure 16.154**.

- (11) Initialize the normal mode waveform generation section with TIOR.
- (12) Disable operation of the normal mode waveform generation section with TIOR.
- (13) Disable output in MTU3 and MTU4 (MTU6 and MTU7) with TOERA (TOERB).
- (14) Select the complementary PWM output level and enable or disable cyclic output with TOCR1A and TOCR2A (TOCR1B and TOCR2B).
- (15) Set complementary PWM mode.
- (16) Enable output in MTU3 and MTU4 (MTU6 and MTU7) with TOERA (TOERB).
- (17) Set MTU output using the port mode control registers (PMCn) and Port function control registers (PFCm) corresponding to the GPIO ports.
- (18) Restart operation by setting TSTRA (TSTRB).

(6) Operation When Error Occurs in Normal Mode and Operation is Restarted in Reset-Synchronized PWM Mode

Figure 16.159 shows a case in which an error occurs in normal mode and operation is restarted in reset-synchronized PWM mode after re-setting.

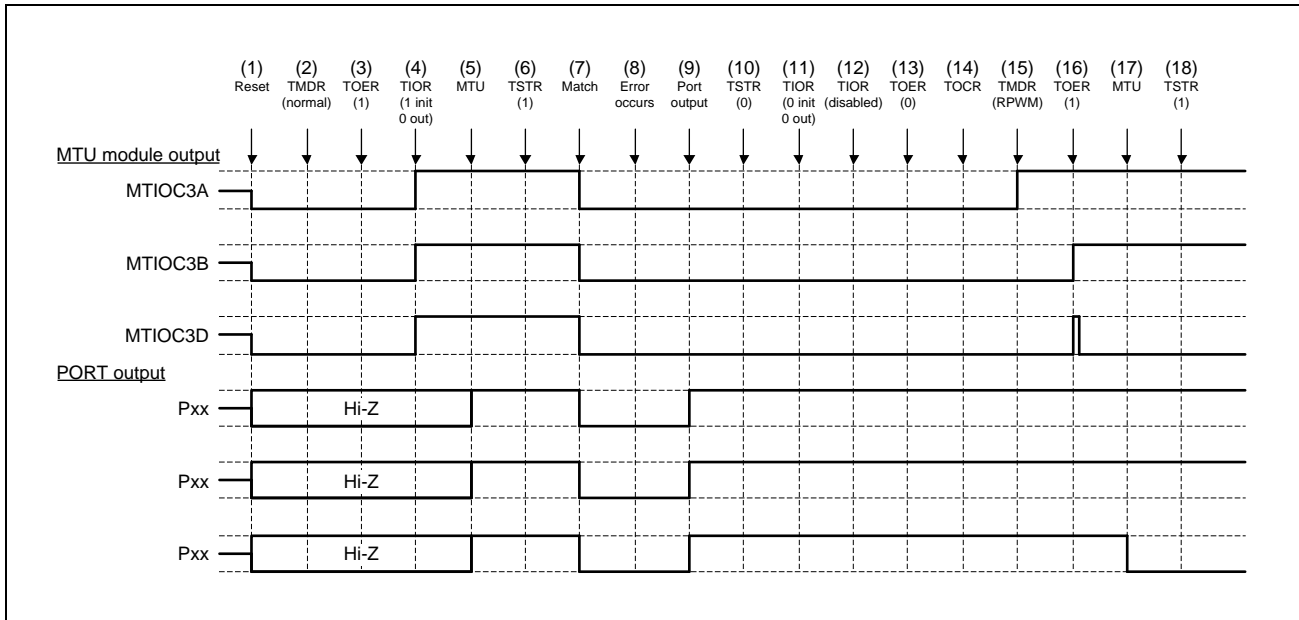

Figure 16.159 Error Occurrence in Normal Mode, Recovery in Reset-Synchronized PWM Mode

(1) to (13) are the same as in **Figure 16.156**.

(14) Select the reset-synchronized PWM output level and enable or disable cyclic output with TOCR1A and TOCR2A (TOCR1B and TOCR2B).

(15) Set reset-synchronized PWM mode.

(16) Enable output from MTU3 and MTU4 (MTU6 and MTU7) with TOERA (TOERB).

(17) Set MTU output using the port mode control registers (PMCn) and Port function control registers (PFCm) corresponding to the GPIO ports.

(18) Restart operation by setting TSTRA (TSTRB).

(7) Operation When Error Occurs in PWM Mode 1 and Operation is Restarted in Normal Mode

Figure 16.160 shows a case in which an error occurs in PWM mode 1 and operation is restarted in normal mode after re-setting.

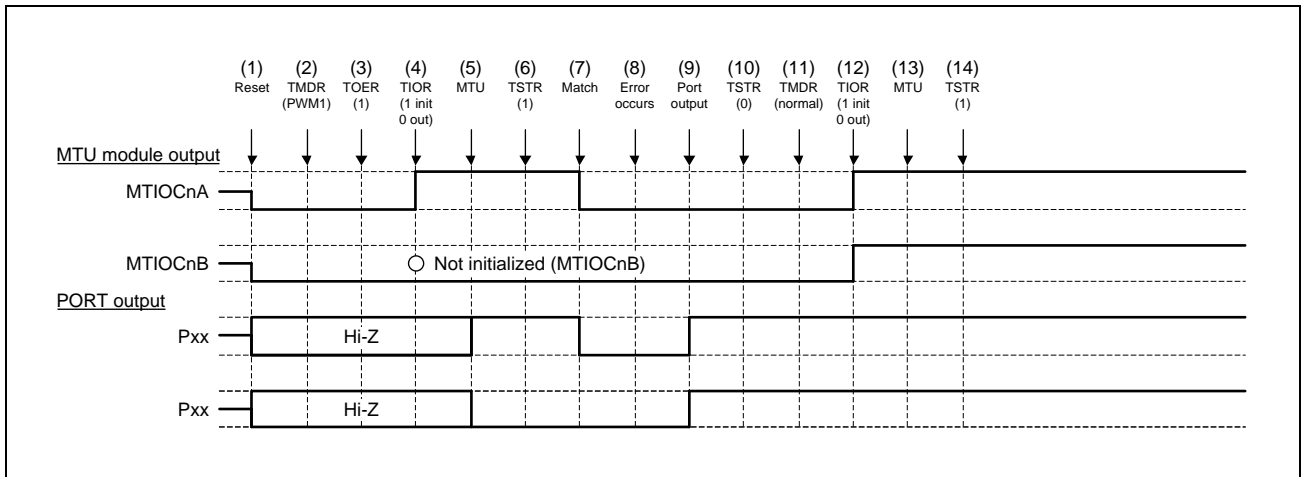

Figure 16.160 Error Occurrence in PWM Mode 1, Recovery in Normal Mode

- (1) After a reset, the MTU output goes low and the ports enter high-impedance state.
- (2) Set PWM mode 1.
- (3) For MTU3 and MTU4 (MTU6 and MTU7), enable output with TOERA (TOERB) before initializing the pins with TIOR.
- (4) Initialize the pins with TIOR. (In the example, the initial output is a high level, and a low level is output on compare match occurrence. In PWM mode 1, the MTIOCnB side is not initialized.)
- (5) Set MTU output using the port mode control registers (PMCn) and Port function control registers (PFCm) corresponding to the GPIO ports.
- (6) Start count operation by setting TSTRA (TSTRB).
- (7) Output goes low on compare match occurrence.
- (8) An error occurs.
- (9) Allow non-active level output by setting the pins as general output ports using the port mode registers (PMn), port registers (Pn), and port mode control registers (PMCn) of the I/O ports.
- (10) Stop count operation by setting TSTRA (TSTRB).
- (11) Set normal mode.
- (12) Initialize the pins with TIOR.
- (13) Set MTU output using the port mode control registers (PMCn) and Port function control registers (PFCm) corresponding to the GPIO ports.
- (14) Restart operation by setting TSTRA (TSTRB).

(8) Operation When Error Occurs in PWM Mode 1 and Operation is Restarted in PWM mode 1

Figure 16.161 shows a case in which an error occurs in PWM mode 1 and operation is restarted in PWM mode 1 after re-setting.

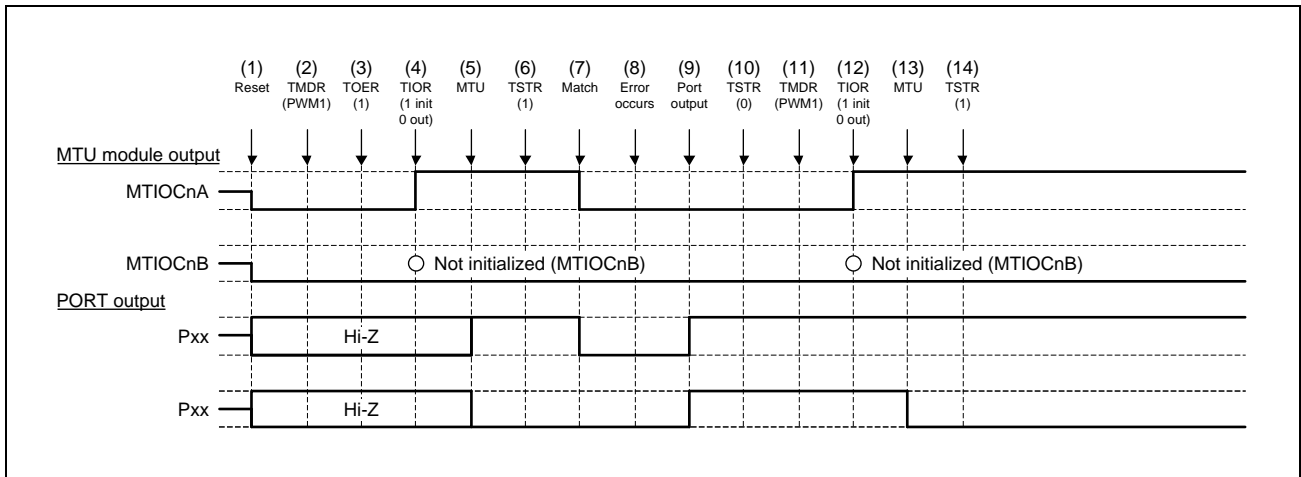

Figure 16.161 Error Occurrence in PWM Mode 1, Recovery in PWM Mode 1

(1) to (10) are the same as in **Figure 16.160**.

(11) This step is not necessary when restarting in PWM mode 1.

(12) Initialize the pins with TIOR. (In PWM mode 1, waveforms are not output to the MTIOCnB (MTIOCnD) pins. To output a specified level, make necessary settings for general output ports in the port mode registers (PMn) and port registers (Pn) of the I/O ports.)

(13) Set MTU output using the port mode control registers (PMcn) and Port function control registers (PFCm) corresponding to the GPIO ports.

(14) Restart operation by setting TSTRA (TSTRB).

(9) Operation When Error Occurs in PWM Mode 1 and Operation is Restarted in PWM mode 2

Figure 16.162 shows a case in which an error occurs in PWM mode 1 and operation is restarted in PWM mode 2 after re-setting.

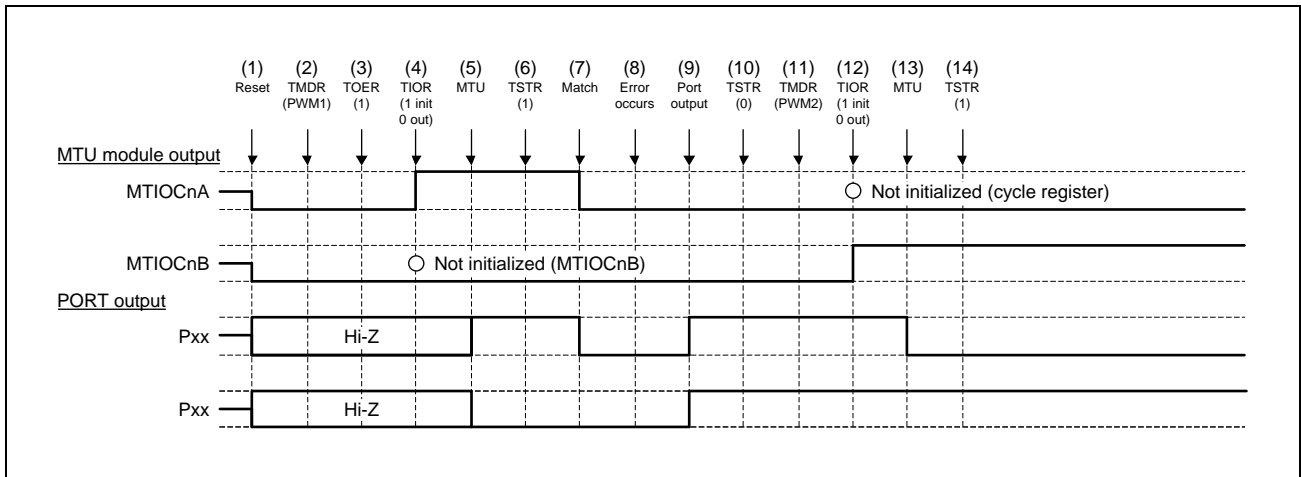

Figure 16.162 Error Occurrence in PWM Mode 1, Recovery in PWM Mode 2

(1) to (10) are the same as in **Figure 16.160**.

(11) Set PWM mode 2.

(12) Initialize the pins with TIOR. (In PWM mode 2, waveforms are not output to the pins corresponding to the TGR registers used as cycle registers.

To output a specified level, make necessary settings for general output ports in the port mode registers (PMn) and port registers (Pn) of the I/O ports.)

(13) Set MTU output using the port mode control registers (PMCn) and Port function control registers (PFCm) corresponding to the GPIO ports.

(14) Restart operation by setting TSTRA.

NOTE

PWM mode 2 can only be selected for MTU0 to MTU2, and therefore TOERA setting is not necessary.

(10) Operation When Error Occurs in PWM Mode 1 and Operation is Restarted in Phase Counting Mode

Figure 16.163 shows a case in which an error occurs in PWM mode 1 and operation is restarted in phase counting mode after re-setting.

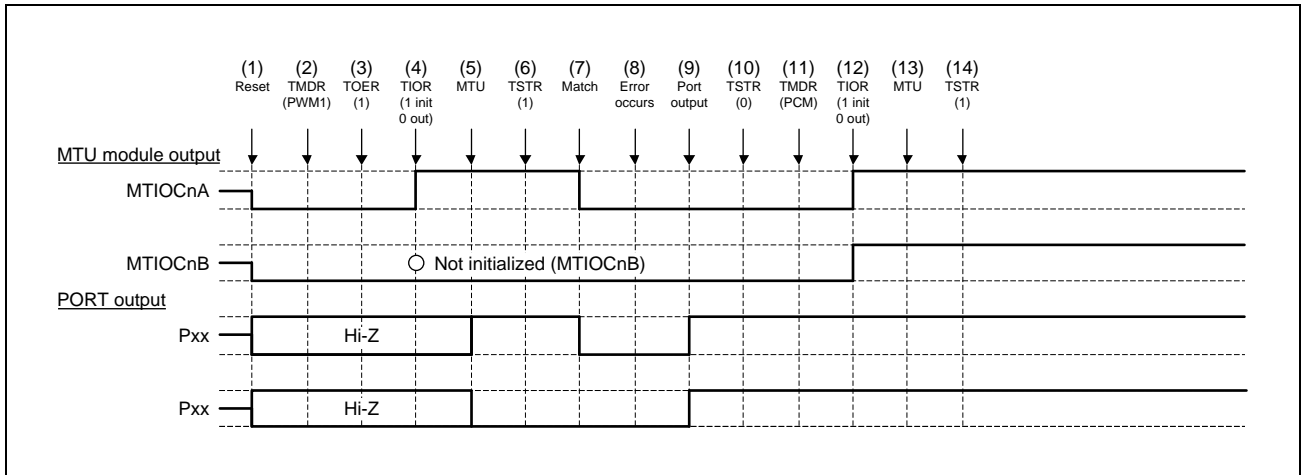

Figure 16.163 Error Occurrence in PWM Mode 1, Recovery in Phase Counting Mode

(1) to (10) are the same as in **Figure 16.160**.

(11) Set the phase counting mode.

(12) Initialize the pins with TIOR.

(13) Set MTU output using the port mode control registers (PMCn) and Port function control registers (PFCm) corresponding to the GPIO ports.

(14) Restart operation by setting TSTR.

NOTE

The phase counting mode can only be selected for MTU1 and MTU2, and therefore TOERA setting is not necessary.

(11) Operation When Error Occurs in PWM Mode 1 and Operation is Restarted in Complementary PWM Mode

Figure 16.164 shows a case in which an error occurs in PWM mode 1 and operation is restarted in complementary PWM mode after re-setting.

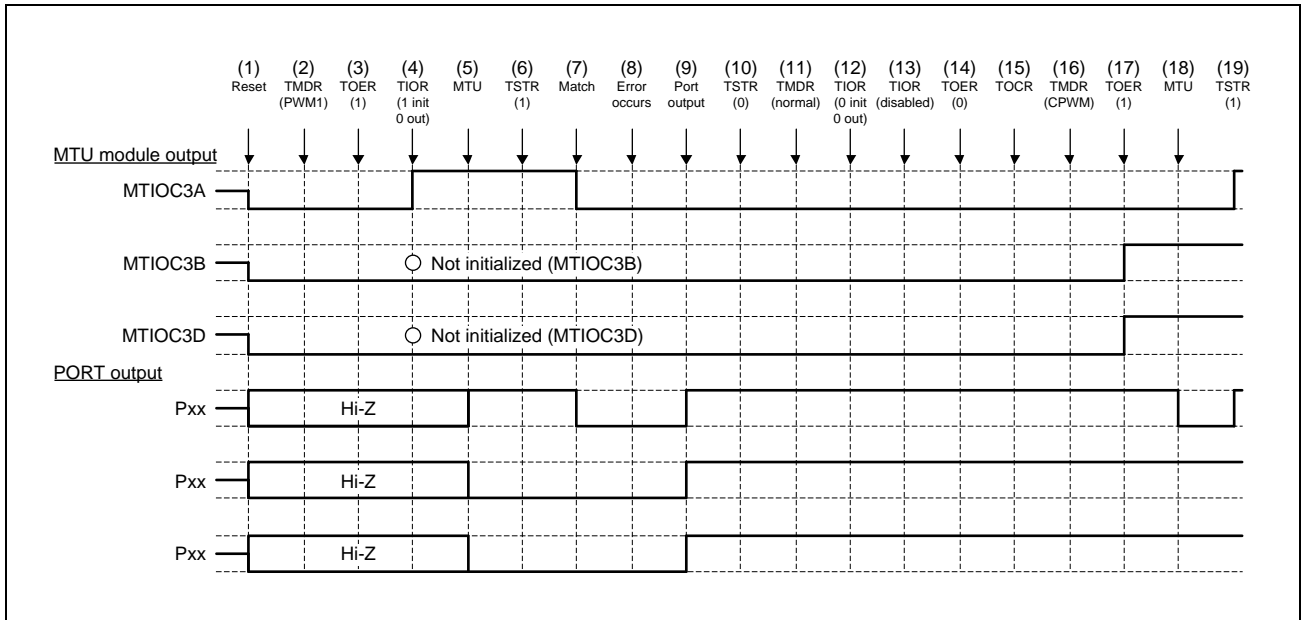

Figure 16.164 Error Occurrence in PWM Mode 1, Recovery in Complementary PWM Mode

(1) to (10) are the same as in **Figure 16.160**.

- (11) Set normal mode to initialize the normal mode waveform generation section.
- (12) Initialize the PWM mode 1 waveform generation section with TIOR.
- (13) Disable operation of the PWM mode 1 waveform generation section with TIOR
- (14) Disable output in MTU3 and MTU4 (MTU6 and MTU7) with TOERA (TOERB).
- (15) Select the complementary PWM output level and enable or disable cyclic output with TOCR1A and TOCR2A (TOCR1B and TOCR2B).
- (16) Set complementary PWM mode.
- (17) Enable output in MTU3 and MTU4 (MTU6 and MTU7) with TOERA (TOERB).
- (18) Set MTU output using the port mode control registers (PMCn) and Port function control registers (PFCm) corresponding to the GPIO ports.
- (19) Restart operation by setting TSTRA (TSTRB).

(12) Operation When Error Occurs in PWM Mode 1 and Operation is Restarted in Reset- Synchronized PWM Mode

Figure 16.165 shows a case in which an error occurs in PWM mode 1 and operation is restarted in reset-synchronized PWM mode after re-setting.

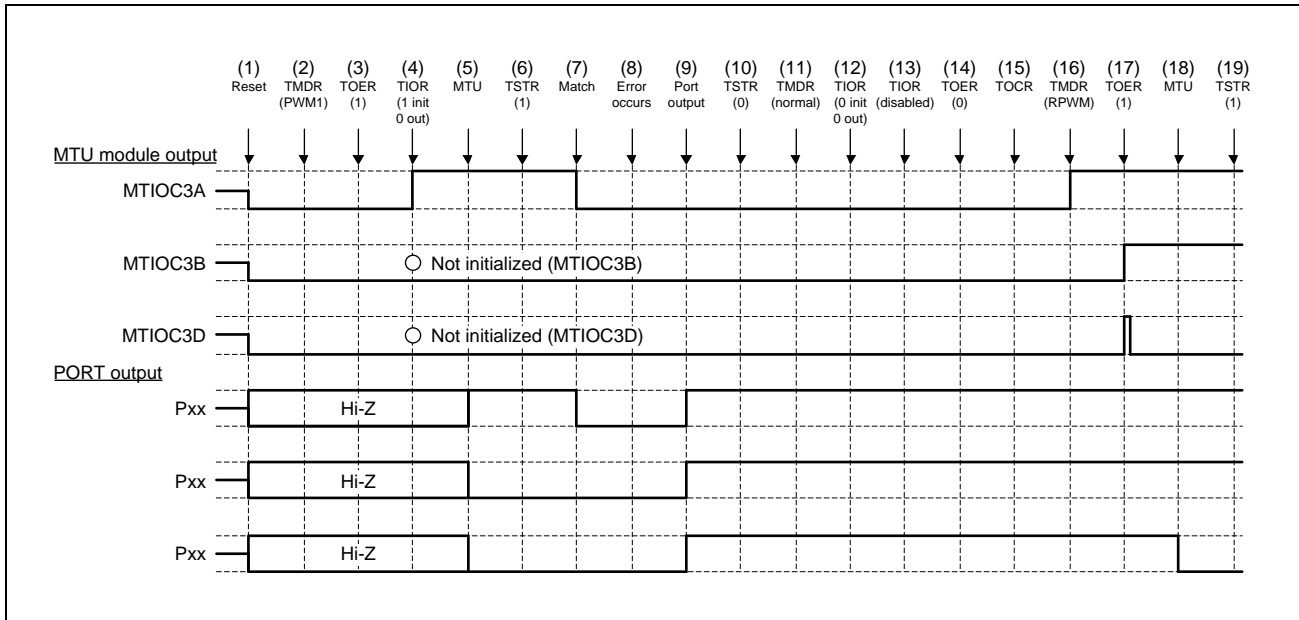

Figure 16.165 Error Occurrence in PWM Mode 1, Recovery in Reset-Synchronized PWM Mode

(1) to (14) are the same as in **Figure 16.164**.

(15) Select the reset-synchronized PWM output level and enable or disable cyclic output with TOCR1A and TOCR2A (TOCR1B and TOCR2B).

(16) Set reset-synchronized PWM mode.

(17) Enable output in MTU3 and MTU4 (MTU6 and MTU7) with TOERA (TOERB).

(18) Set MTU output using the port mode control registers (PMCn) and Port function control registers (PFCm) corresponding to the GPIO ports.

(19) Restart operation by setting TSTRA (TSTRB).

(13) Operation When Error Occurs in PWM Mode 2 and Operation is Restarted in Normal Mode

Figure 16.166 shows a case in which an error occurs in PWM mode 2 and operation is restarted in normal mode after re-setting.

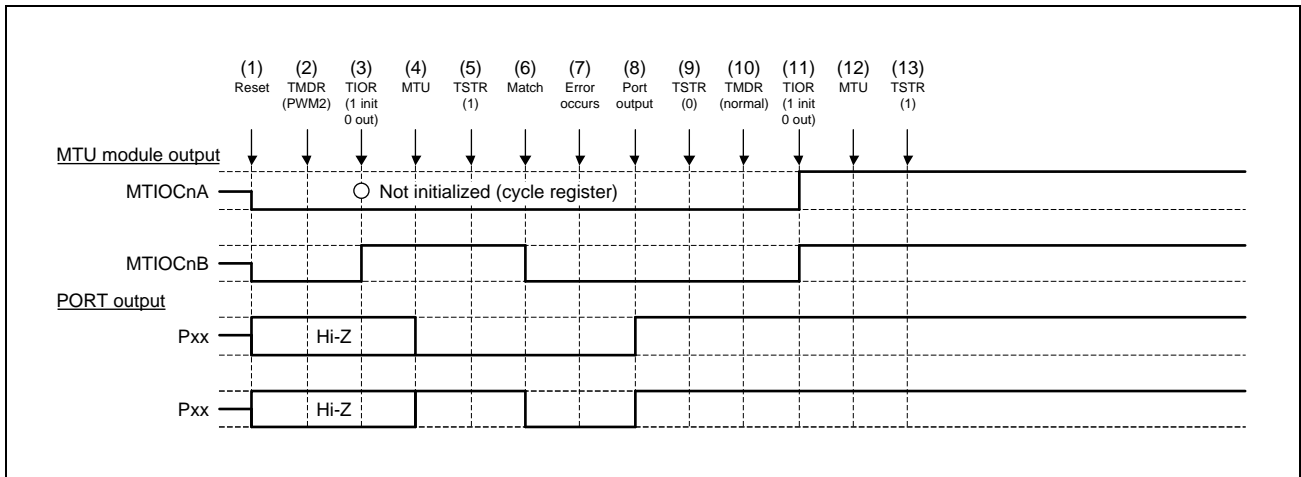

Figure 16.166 Error Occurrence in PWM Mode 2, Recovery in Normal Mode

- (1) After a reset, the MTU output goes low and the ports enter high-impedance state.
- (2) Set PWM mode 2.
- (3) Initialize the pins with TIOR. (In the example, the initial output is a high level, and a low level is output on compare match occurrence. In PWM mode 2, the pins corresponding to the TGR registers used as cycle registers are not initialized. In the example, TGRA in MTU_n is used as a cycle register.)
- (4) Set MTU output using the port mode control registers (PMC_n) and Port function control registers (PFC_m) corresponding to the GPIO ports.
- (5) Start count operation by setting TSTR_A.
- (6) Output goes low on compare match occurrence.
- (7) An error occurs.
- (8) Allow non-active level output by setting the pins as general output ports using the port mode registers (PM_n), port registers (P_n), and port mode control registers (PMC_n) of the I/O ports.
- (9) Stop count operation by setting TSTR_A.
- (10) Set normal mode.
- (11) Initialize the pins with TIOR.
- (12) Set MTU output using the port mode control registers (PMC_n) and Port function control registers (PFC_m) corresponding to the GPIO ports.
- (13) Restart operation by setting TSTR_A.

(14) Operation When Error Occurs in PWM Mode 2 and Operation is Restarted in PWM Mode 1

Figure 16.167 shows a case in which an error occurs in PWM mode 2 and operation is restarted in PWM mode 1 after re-setting.

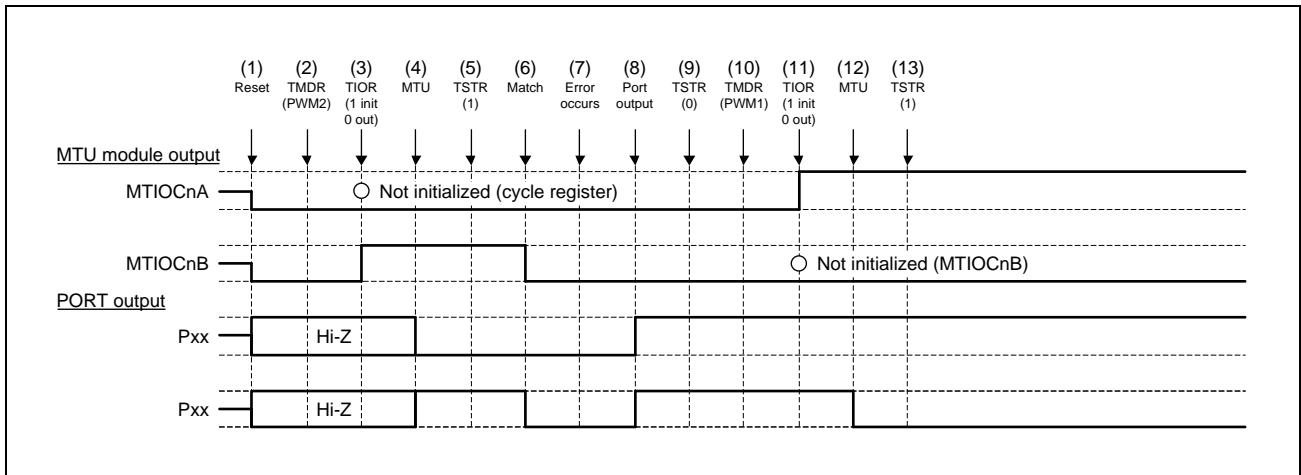

Figure 16.167 Error Occurrence in PWM Mode 2, Recovery in PWM Mode 1

(1) to (9) are the same as in **Figure 16.166**.

(10) Set PWM mode 1.

(11) Initialize the pins with TIOR. (In PWM mode 1, waveforms are not output to the MTIOcNB (MTIOcND) pins. To output a specified level, make necessary settings for general output ports in the port mode registers (PMn) and port registers (Pn) of the I/O ports.)

(12) Set MTU output using the port mode control registers (PMCn) and Port function control registers (PFCm) corresponding to the GPIO ports.

(13) Restart operation by setting TSTR.

(15) Operation When Error Occurs in PWM Mode 2 and Operation is Restarted in PWM Mode 2

Figure 16.168 shows a case in which an error occurs in PWM mode 2 and operation is restarted in PWM mode 2 after re-setting.

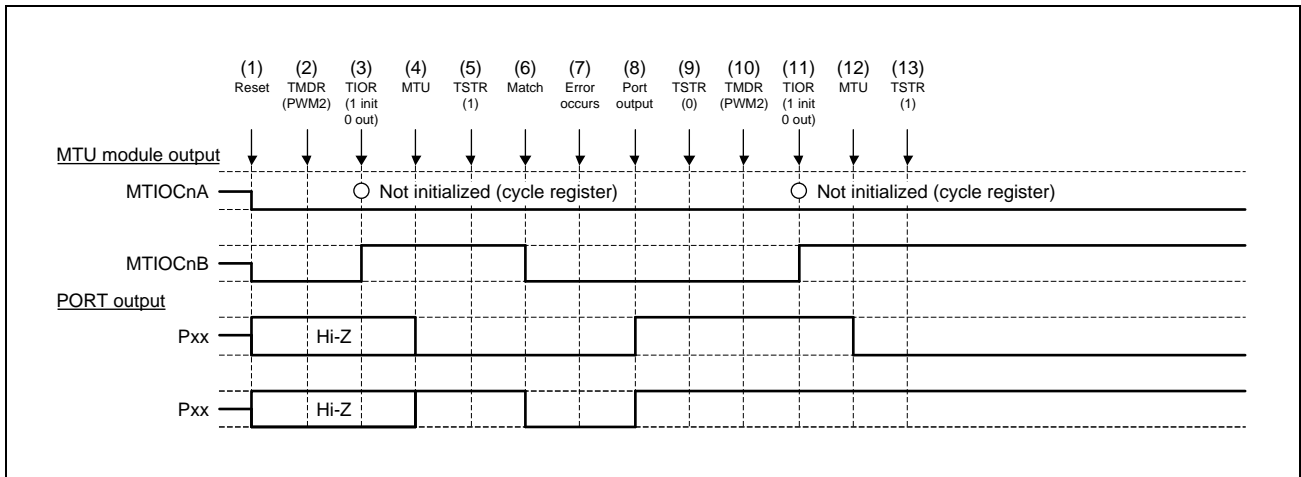

Figure 16.168 Error Occurrence in PWM Mode 2, Recovery in PWM Mode 2

(1) to (9) are the same as in **Figure 16.166**.

(10) This step is not necessary when restarting in PWM mode 2.

(11) Initialize the pins with TIOR. (In PWM mode 2, waveforms are not output to the pins corresponding to the TGR registers used as cycle registers.)

To output a specified level, make necessary settings for general output ports in the port mode registers (PMn) and port registers (Pn) of the I/O ports.)

(12) Set MTU output using the port mode control registers (PMCn) and Port function control registers (PFCm) corresponding to the GPIO ports.

(13) Restart operation by setting TSTRA.

(16) Operation When Error Occurs in PWM Mode 2 and Operation is Restarted in Phase Counting Mode

Figure 16.169 shows a case in which an error occurs in PWM mode 2 and operation is restarted in phase counting mode after re-setting.

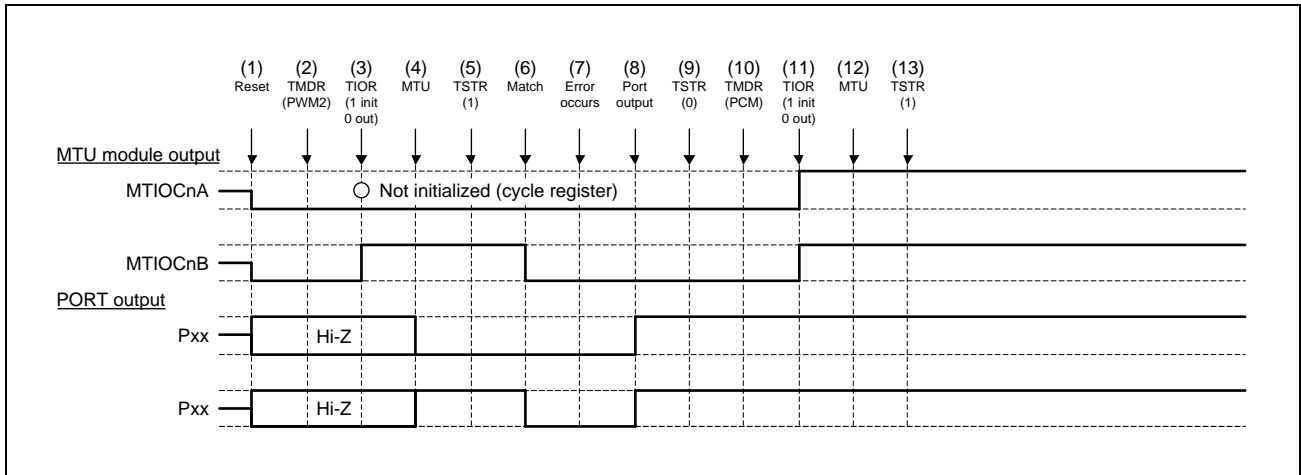

Figure 16.169 Error Occurrence in PWM Mode 2, Recovery in Phase Counting Mode

(1) to (9) are the same as in **Figure 16.166**.

(10) Set the phase counting mode.

(11) Initialize the pins with TIOR.

(12) Set MTU output using the port mode control registers (PMCn) and Port function control registers (PFCm) corresponding to the GPIO ports.

(13) Restart operation by setting TSTR.

(17) Operation When Error Occurs in Phase Counting Mode and Operation is Restarted in Normal Mode

Figure 16.170 shows a case in which an error occurs in phase counting mode and operation is restarted in normal mode after re-setting.

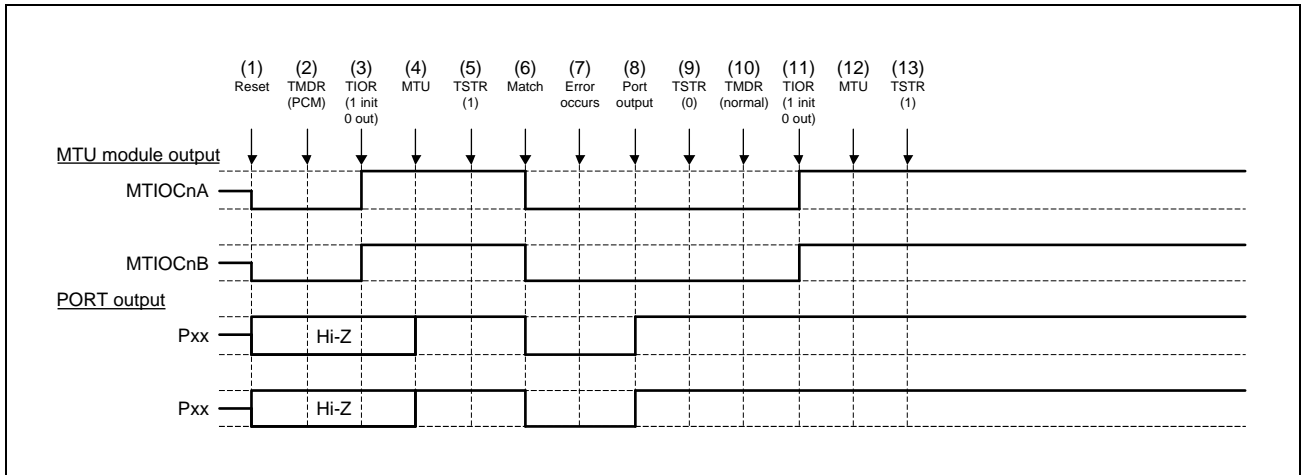

Figure 16.170 Error Occurrence in Phase Counting Mode, Recovery in Normal Mode

- (1) After a reset, the MTU output goes low and the ports enter high-impedance state.
- (2) Set phase counting mode.
- (3) Initialize the pins with TIOR. (In the example, the initial output is a high level, and a low level is output on compare match occurrence.)
- (4) Set MTU output using the port mode control registers (PMcN) and Port function control registers (PFCm) corresponding to the GPIO ports.
- (5) Start count operation by setting TSTR.
- (6) Output goes low on compare match occurrence.
- (7) An error occurs.
- (8) Allow non-active level output by setting the pins as general output ports using the port mode registers (PMn), port registers (Pn), and port mode control registers (PMcN) of the I/O ports.
- (9) Stop count operation by setting TSTR.
- (10) Set normal mode.
- (11) Initialize the pins with TIOR.
- (12) Set MTU output using the port mode control registers (PMcN) and Port function control registers (PFCm) corresponding to the GPIO ports.
- (13) Restart operation by setting TSTR.

(18) Operation When Error Occurs in Phase Counting Mode and Operation is Restarted in PWM Mode 1

Figure 16.171 shows a case in which an error occurs in phase counting mode and operation is restarted in PWM mode 1 after re-setting.

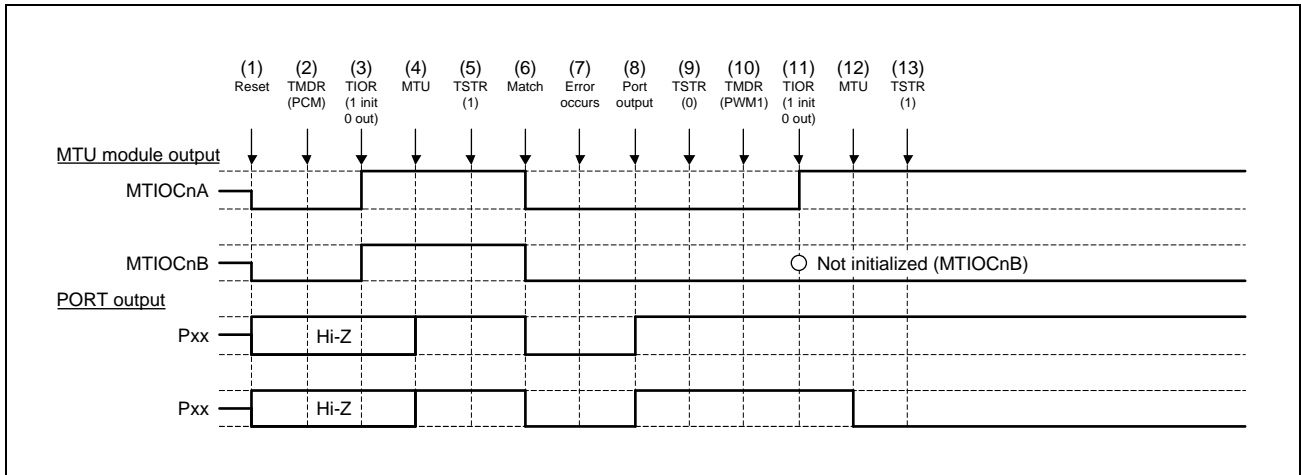

Figure 16.171 Error Occurrence in Phase Counting Mode, Recovery in PWM Mode 1

(1) to (9) are the same as in **Figure 16.170**.

(10) Set PWM mode 1.

(11) Initialize the pins with TIOR. (In PWM mode 1, waveforms are not output to the MTIOCnB (MTIOCnD) pins. To output a specified level, make necessary settings for general output ports in the port mode registers (PMn) and port registers (Pn) of the I/O ports.)

(12) Set MTU output using the port mode control registers (PMcn) and Port function control registers (PFCm) corresponding to the GPIO ports.

(13) Restart operation by setting TSTR.

(19) Operation When Error Occurs in Phase Counting Mode and Operation is Restarted in PWM Mode 2

Figure 16.172 shows a case in which an error occurs in phase counting mode and operation is restarted in PWM mode 2 after re-setting.

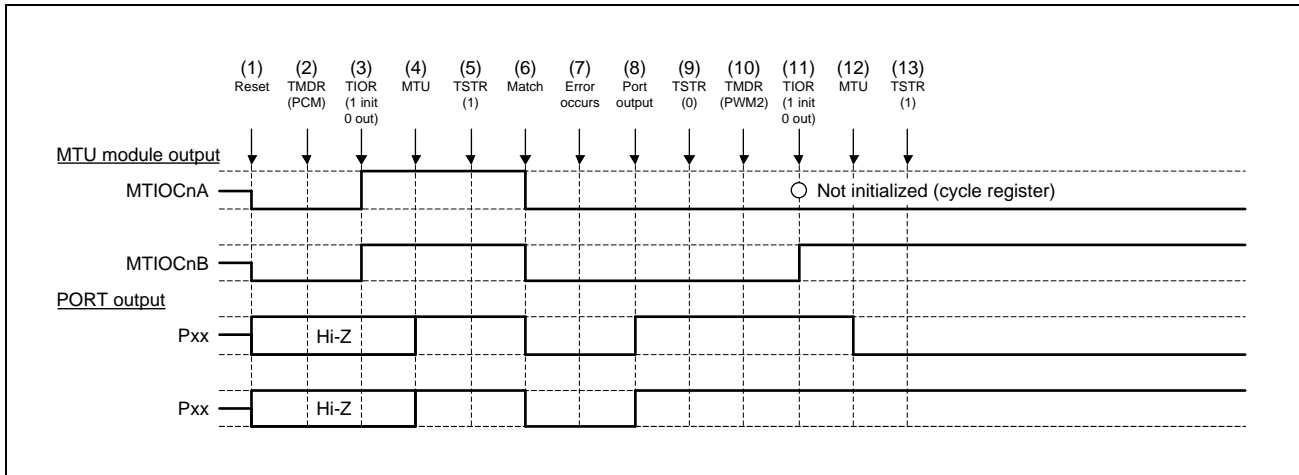

Figure 16.172 Error Occurrence in Phase Counting Mode, Recovery in PWM Mode 2

(1) to (9) are the same as in **Figure 16.170**.

(10) Set PWM mode 2.

(11) Initialize the pins with TIOR. (In PWM mode 2, waveforms are not output to the pins corresponding to the TGR registers used as cycle registers.)

To output a specified level, make necessary settings for general output ports in the port mode registers (PMn) and port registers (Pn) of the I/O ports.)

(12) Set MTU output using the port mode control registers (PMCn) and Port function control registers (PFCm) corresponding to the GPIO ports.

(13) Restart operation by setting TSTR.

(20) Operation When Error Occurs in Phase Counting Mode and Operation is Restarted in Phase Counting Mode

Figure 16.173 shows a case in which an error occurs in phase counting mode and operation is restarted in phase counting mode after re-setting.

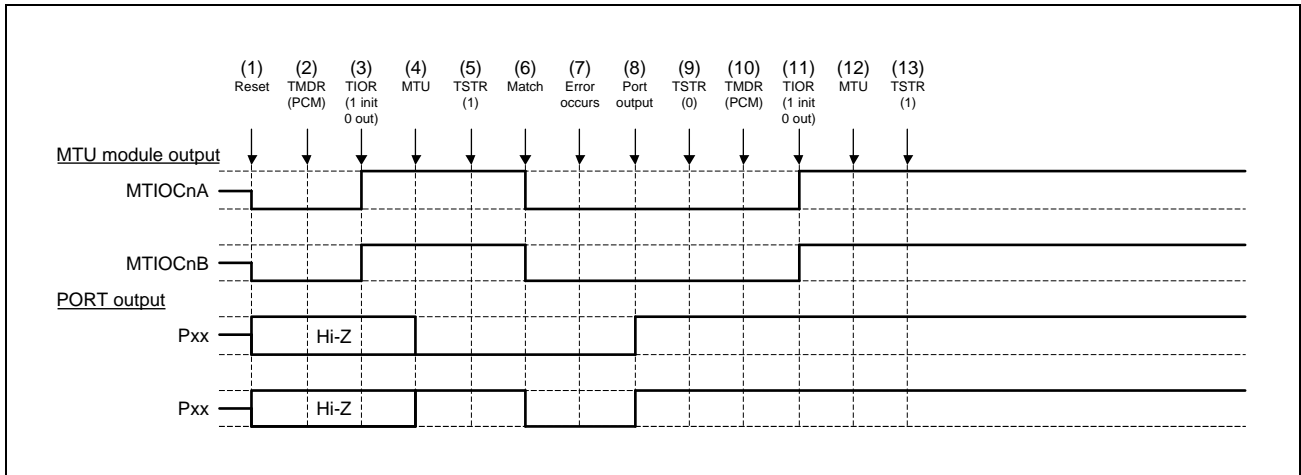

Figure 16.173 Error Occurrence in Phase Counting Mode, Recovery in Phase Counting Mode

(1) to (9) are the same as in **Figure 16.170**.

(10) This step is not necessary when restarting in phase counting mode.

(11) Initialize the pins with TIOR.

(12) Set MTU output using the port mode control registers (PMcN) and Port function control registers (PFCm) corresponding to the GPIO ports.

(13) Restart operation by setting TSTR.

(21) Operation When Error Occurs in Complementary PWM Mode and Operation is Restarted in Normal Mode

Figure 16.174 shows a case in which an error occurs in complementary PWM mode and operation is restarted in normal mode after re-setting.

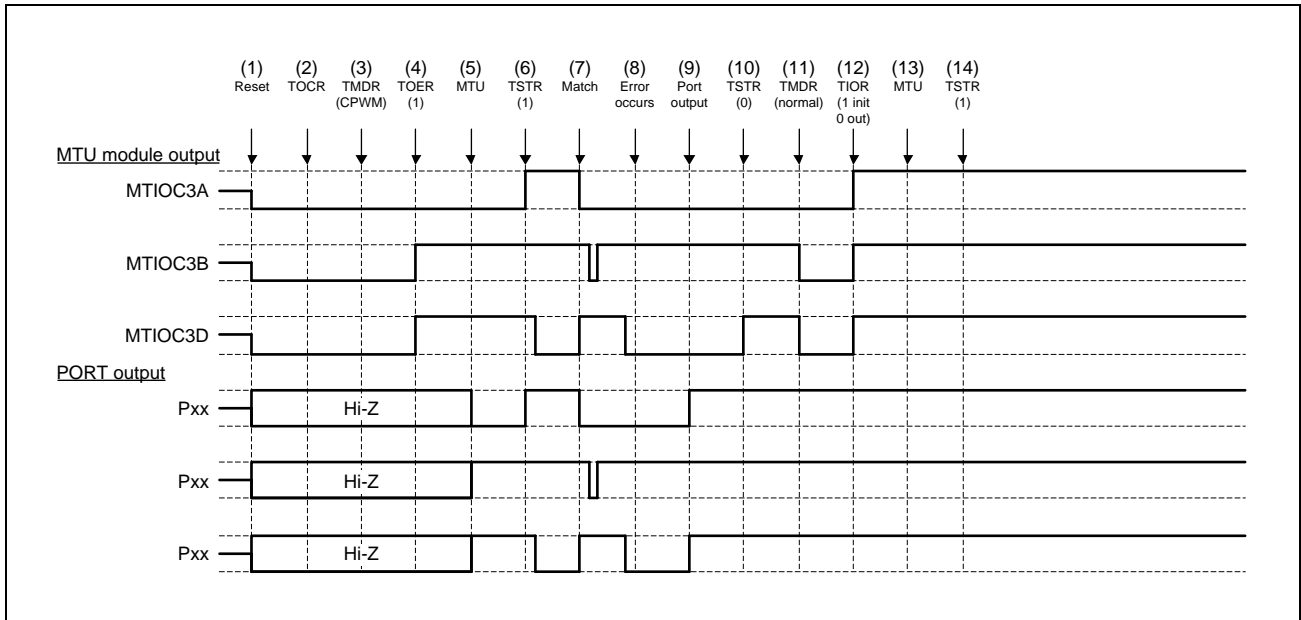

Figure 16.174 Error Occurrence in Complementary PWM Mode, Recovery in Normal Mode

- (1) After a reset, the MTU3 output goes low and the ports enter high-impedance state.
- (2) Select the complementary PWM output level and enable or disable cyclic output with TOCR1A and TOCR2A (TOCR1B and TOCR2B).
- (3) Set complementary PWM mode.
- (4) Enable output in MTU3 and MTU4 (MTU6 and MTU7) with TOERA (TOERB).
- (5) Set MTU output using the port mode control registers (PMCn) and Port function control registers (PFCm) corresponding to the GPIO ports.
- (6) Start count operation by setting TSTR (TSTRB).
- (7) The complementary PWM waveform is output on compare match occurrence.
- (8) An error occurs.
- (9) Allow non-active level output by setting the pins as general output ports using the port mode registers (PMn), port registers (Pn), and port mode control registers (PMCn) of the I/O ports.
- (10) Stop count operation by setting TSTR (TSTRB). (MTU output becomes the initial complementary PWM output value).
- (11) Set normal mode (MTU output goes low).
- (12) Initialize the pins with TIOR.
- (13) Set MTU output using the port mode control registers (PMCn) and Port function control registers (PFCm) corresponding to the GPIO ports.
- (14) Restart operation by setting TSTR (TSTRB).

(22) Operation When Error Occurs in Complementary PWM Mode and Operation is Restarted in PWM Mode 1

Figure 16.175 shows a case in which an error occurs in complementary PWM mode and operation is restarted in PWM mode 1 after re-setting.

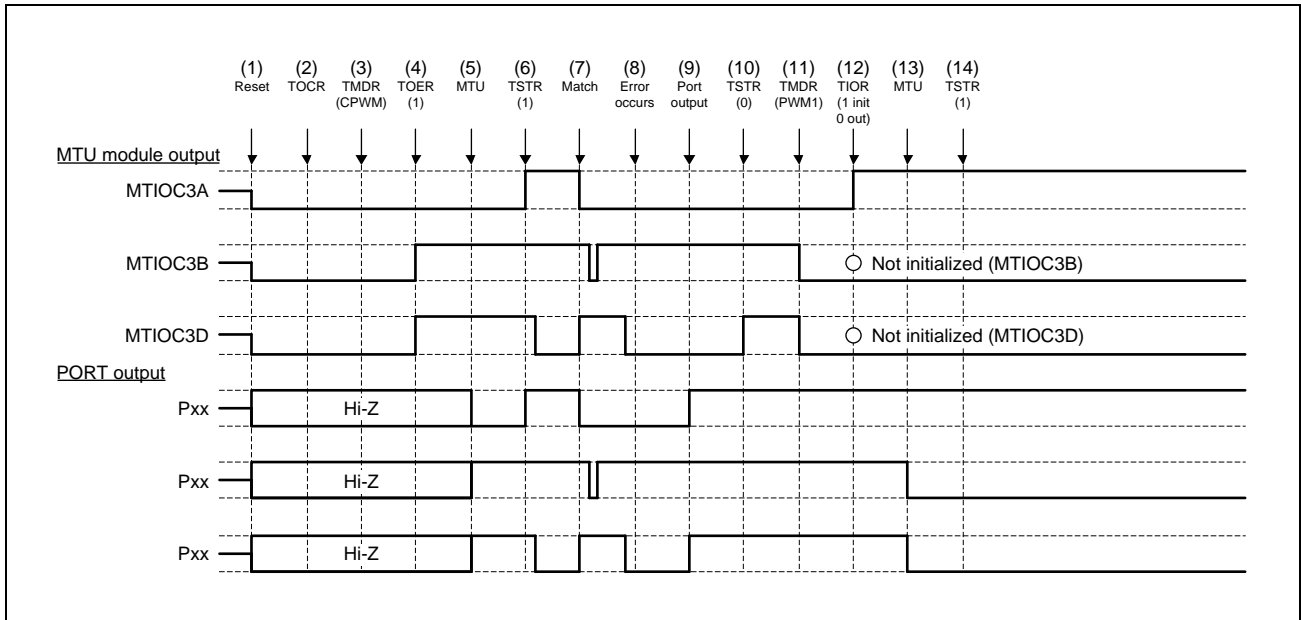

Figure 16.175 Error Occurrence in Complementary PWM Mode, Recovery in PWM Mode 1

(1) to (10) are the same as in **Figure 16.174**.

(11) Set PWM mode 1 (MTU output goes low).

(12) Initialize the pins with TIOR. (In PWM mode 1, waveforms are not output to the MTIOCnB (MTIOCnD) pins. To output a specified level, make necessary settings for general output ports in the port mode registers (PMn) and port registers (Pn) of the I/O ports.)

(13) Set MTU output using the port mode control registers (PMcn) and Port function control registers (PFCm) corresponding to the GPIO ports.

(14) Restart operation by setting TSTRA (TSTRB).

(23) Operation When Error Occurs in Complementary PWM Mode and Operation is Restarted in Complementary PWM Mode

Figure 16.176 shows a case in which an error occurs in complementary PWM mode and operation is restarted in complementary PWM mode after re-setting (when operation is restarted using the cycle and duty settings at the time of stopping the counter).

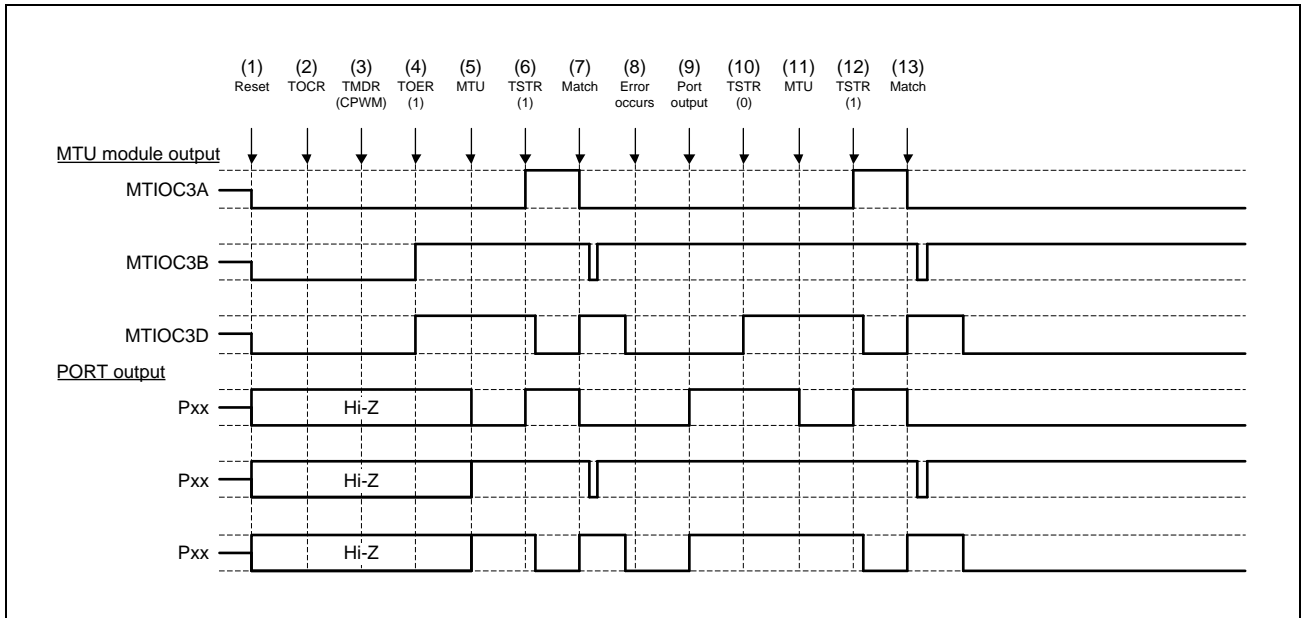

Figure 16.176 Error Occurrence in Complementary PWM Mode, Recovery in Complementary PWM Mode (1)

(1) to (10) are the same as in **Figure 16.174**.

(11) Set MTU output using the port mode control registers (PMCn) and Port function control registers (PFCm) corresponding to the GPIO ports.

(12) Restart operation by setting TSTRA (TSTRB).

(13) The complementary PWM waveform is output on compare match occurrence.

(24) Operation When Error Occurs in Complementary PWM Mode and Operation is Restarted in Complementary PWM Mode with New Settings

Figure 16.177 shows a case in which an error occurs in complementary PWM mode and operation is restarted in complementary PWM mode after re-setting (operation is restarted using new cycle and duty ratio settings).

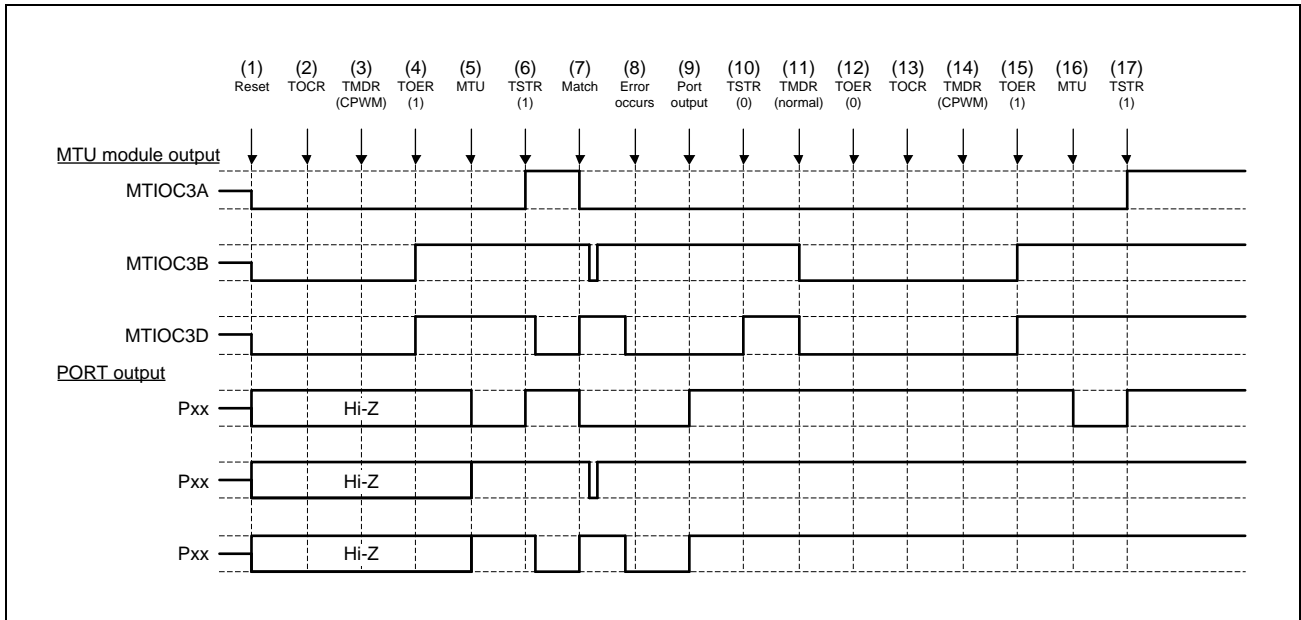

Figure 16.177 Error Occurrence in Complementary PWM Mode, Recovery in Complementary PWM Mode (2)

(1) to (10) are the same as in **Figure 16.174**.

(11) Set normal mode and make new settings (MTU output goes low).

(12) Disable output in MTU3 and MTU4 (MTU6 and MTU7) with TOERA (TOERB).

(13) Select the complementary PWM output level and enable or disable cyclic output with TOCR1A and TOCR2A (TOCR1B and TOCR2B).

(14) Set complementary PWM mode.

(15) Enable output in MTU3 and MTU4 (MTU6 and MTU7) with TOERA (TOERB).

(16) Set MTU output using the port mode control registers (PMCn) and Port function control registers (PFCm) corresponding to the GPIO ports.

(17) Restart operation by setting TSTRA (TSTRB).

(25) Operation When Error Occurs in Complementary PWM Mode and Operation is Restarted in Reset-Synchronized PWM Mode

Figure 16.178 shows a case in which an error occurs in complementary PWM mode and operation is restarted in reset- synchronized PWM mode after re-setting.

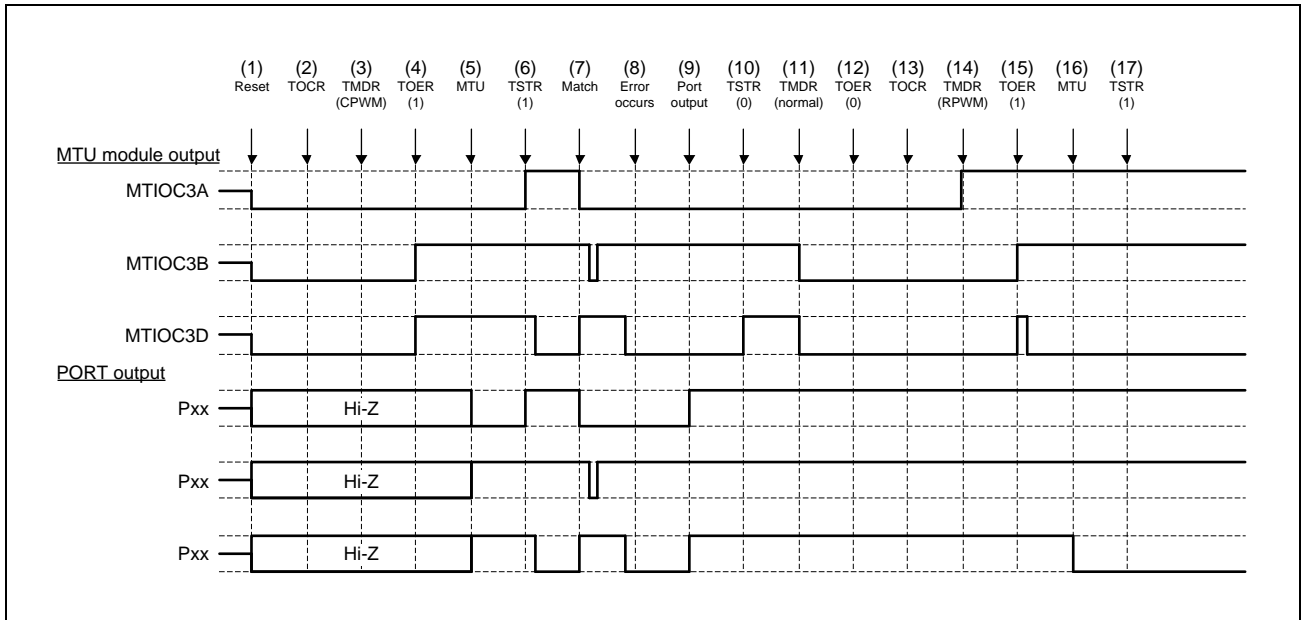

Figure 16.178 Error Occurrence in Complementary PWM Mode, Recovery in Reset-Synchronized PWM Mode

(1) to (10) are the same as in **Figure 16.174**.

(11) Set normal mode (MTU output goes low).

(12) Disable output in MTU3 and MTU4 (MTU6 and MTU7) with TOERA (TOERB).

(13) Select the reset-synchronized PWM output level and enable or disable cyclic output with TOCR1A and TOCR2A (TOCR1B and TOCR2B).

(14) Set reset-synchronized PWM mode.

(15) Enable output in MTU3 and MTU4 (MTU6 and MTU7) with TOERA (TOERB).

(16) Set MTU output using the port mode control registers (PMCn) and Port function control registers (PFCm) corresponding to the GPIO ports.

(17) Restart operation by setting TSTRA (TSTRB).

(26) Operation When Error Occurs in Reset-Synchronized PWM Mode and Operation is Restarted in Normal Mode

Figure 16.179 shows a case in which an error occurs in reset-synchronized PWM mode and operation is restarted in normal mode after re-setting.

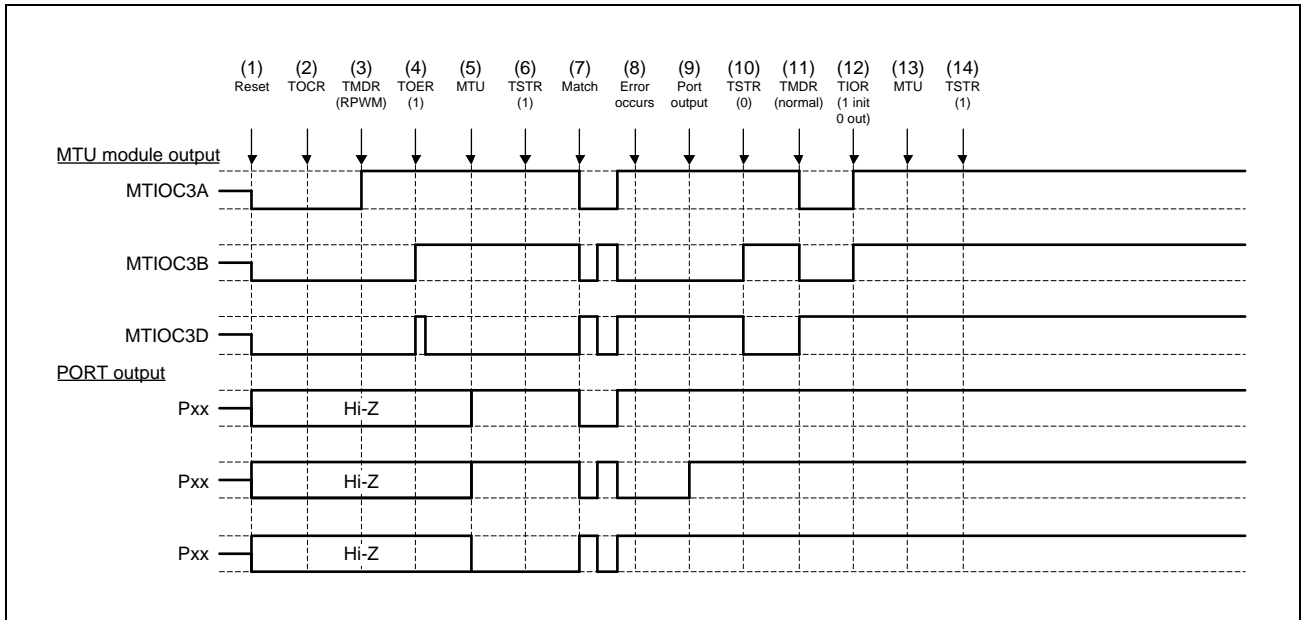

Figure 16.179 Error Occurrence in Reset-Synchronized PWM Mode, Recovery in Normal Mode

- (1) After a reset, the MTU output goes low and the ports enter high-impedance state.
- (2) Select the reset-synchronized PWM output level and enable or disable cyclic output with TOCR1A and TOCR2A (TOCR1B and TOCR2B).
- (3) Set reset-synchronized PWM mode.
- (4) Enable output in MTU3 and MTU4 (MTU6 and MTU7) with TOERA (TOERB).
- (5) Set MTU output using the port mode control registers (PMCn) and Port function control registers (PFCm) corresponding to the GPIO ports.
- (6) Start count operation by setting TSTRA (TSTRB).
- (7) The reset-synchronized PWM waveform is output on compare match occurrence.
- (8) An error occurs.
- (9) Allow non-active level output by setting the pins as general output ports using the port mode registers (PMn), port registers (Pn), and port mode control registers (PMCn) of the I/O ports.
- (10) Stop count operation by setting TSTRA (TSTRB). (MTU output becomes the initial reset-synchronized PWM output value.)
- (11) Set normal mode (positive-phase MTU output goes low, and negative-phase output goes high).
- (12) Initialize the pins with TIOR.
- (13) Set MTU output using the port mode control registers (PMCn) and Port function control registers (PFCm) corresponding to the GPIO ports.
- (14) Restart operation by setting TSTRA (TSTRB).

(27) Operation When Error Occurs in Reset-Synchronized PWM Mode and Operation is Restarted in PWM Mode 1

Figure 16.180 shows a case in which an error occurs in reset-synchronized PWM mode and operation is restarted in PWM mode 1 after re-setting.

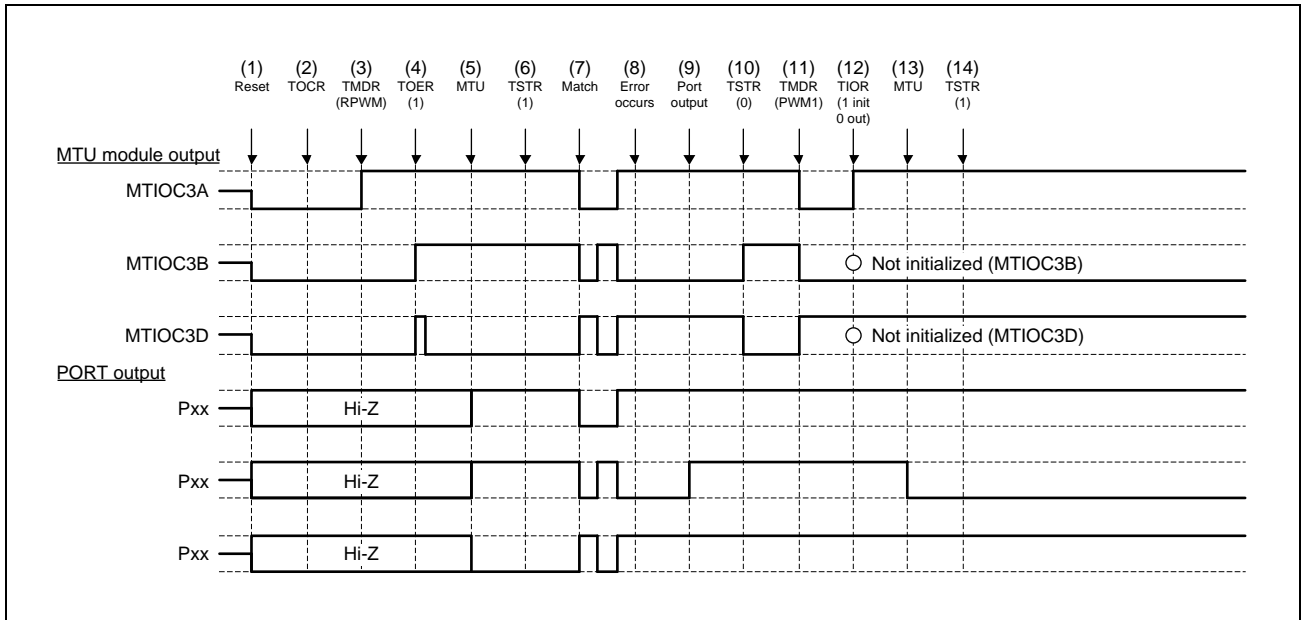

Figure 16.180 Error Occurrence in Reset-Synchronized PWM Mode, Recovery in PWM Mode 1

(1) to (10) are the same as in **Figure 16.179**.

(11) Set PWM mode 1 (positive-phase MTU output goes low, and negative-phase output goes high).

(12) Initialize the pins with TIOR. (In PWM mode 1, waveforms are not output to the MTIOCnB (MTIOCnD) pins. To output a specified level, make necessary settings for general output ports in the port mode registers (PMn) and port registers (Pn) of the I/O ports.)

(13) Set MTU output using the port mode control registers (PMcn) and Port function control registers (PFCm) corresponding to the GPIO ports.

(14) Restart operation by setting TSTRA (TSTRB).

(28) Operation When Error Occurs in Reset-Synchronized PWM Mode and Operation is Restarted in Complementary PWM Mode

Figure 16.181 shows a case in which an error occurs in reset-synchronized PWM mode and operation is restarted in complementary PWM mode after re-setting.

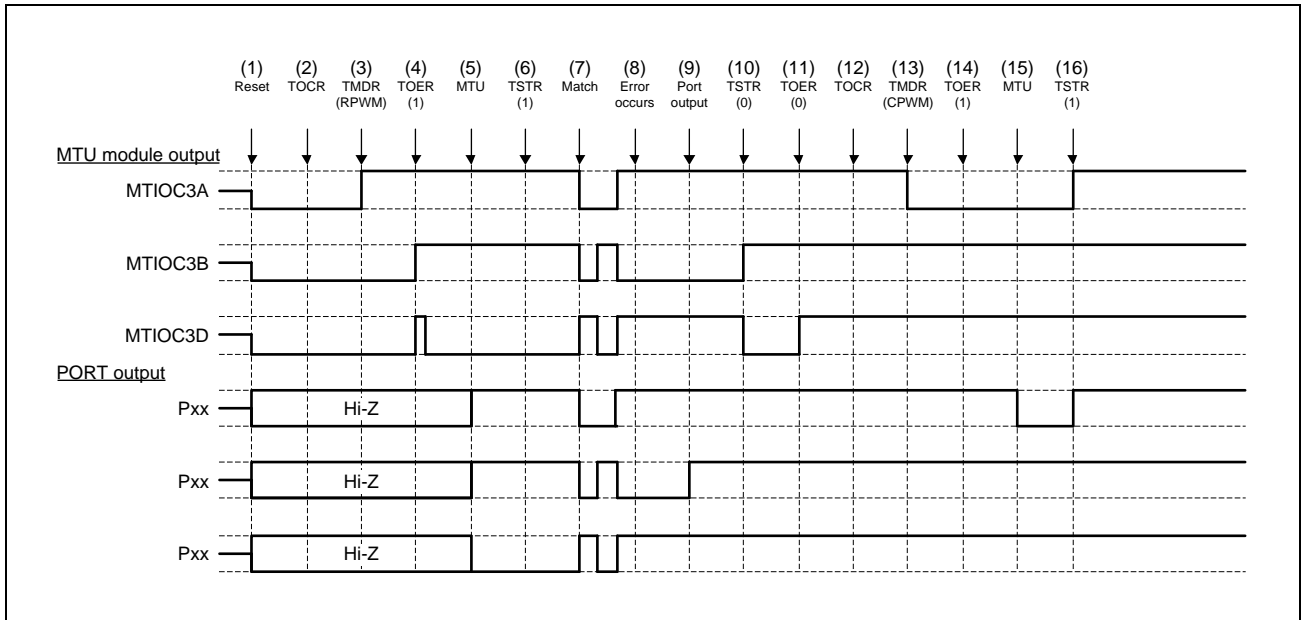

Figure 16.181 Error Occurrence in Reset-Synchronized PWM Mode, Recovery in Complementary PWM Mode

(1) to (10) are the same as in **Figure 16.179**.

(11) Disable output in MTU3 and MTU4 (MTU6 and MTU7) with TOERA (TOERB).

(12) Select the complementary PWM output level and enable or disable cyclic output with TOCR1A and TOCR2A (TOCR1B and TOCR2B).

(13) Set complementary PWM mode (MTU cyclic output pin goes low).

(14) Enable output in MTU3 and MTU4 (MTU6 and MTU7) with TOERA (TOERB).

(15) Set MTU output using the port mode control registers (PMCn) and Port function control registers (PFCm) corresponding to the GPIO ports.

(16) Restart operation by setting TSTRA (TSTRB).

(29) Operation When Error Occurs in Reset-Synchronized PWM Mode and Operation is Restarted in Reset-Synchronized PWM Mode

Figure 16.182 shows a case in which an error occurs in reset-synchronized PWM mode and operation is restarted in reset-synchronized PWM mode after re-setting.

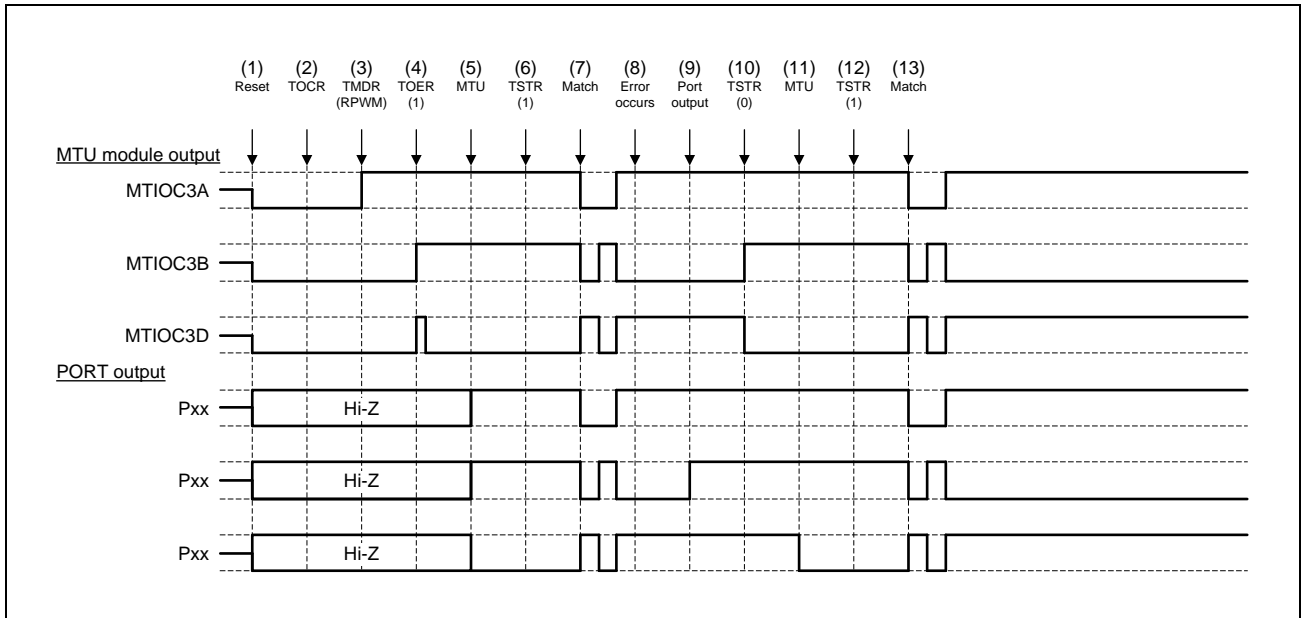

Figure 16.182 Error Occurrence in Reset-Synchronized PWM Mode, Recovery in Reset-Synchronized PWM Mode

(1) to (10) are the same as in **Figure 16.179**.

(11) Set MTU output using the port mode control registers (PMCn) and Port function control registers (PFCm) corresponding to the GPIO ports.

(12) Restart operation by setting TSTRA (TSTRB).

(13) The reset-synchronized PWM waveform is output on compare match occurrence.

17. Port Output Enable 3 (POE3)

The port output enable 3 (POE3) can be used to place output pins for the MTU3a in the high-impedance state in response to various conditions.

17.1 Overview

Table 17.1 lists the specifications of the POE3, and **Figure 17.1** shows a block diagram of the POE3.

Table 17.1 POE3 Specifications

Item	Description														
Target pins to be placed in the high-impedance state	<ul style="list-style-type: none"> MTU3a output pins <ul style="list-style-type: none"> MTU0 pin (MTIOC0A, MTIOC0B, MTIOC0C, MTIOC0D) MTU3 pin (MTIOC3B, MTIOC3D) MTU4 pin (MTIOC4A, MTIOC4B, MTIOC4C, MTIOC4D) MTU6 pin (MTIOC6B, MTIOC6D) MTU7 pin (MTIOC7A, MTIOC7B, MTIOC7C, MTIOC7D) 														
Conditions for the high-impedance state	<ul style="list-style-type: none"> Setting pins as inputs: setting the POE0#, POE4#, POE8#, or POE10# pins as inputs (falling edge or low-level sampling). Short-circuits between output pins: A match (short circuit) between the output signal levels at the active level over one or more cycle on (the following combination of pins) <table border="1" data-bbox="523 1039 983 1272"> <thead> <tr> <th colspan="2">MTU complementary PWM output pins</th> </tr> </thead> <tbody> <tr> <td>1</td> <td>MTIOC3B and MTIOC3D</td> </tr> <tr> <td>2</td> <td>MTIOC4A and MTIOC4C</td> </tr> <tr> <td>3</td> <td>MTIOC4B and MTIOC4D</td> </tr> <tr> <td>4</td> <td>MTIOC6B and MTIOC6D</td> </tr> <tr> <td>5</td> <td>MTIOC7A and MTIOC7C</td> </tr> <tr> <td>6</td> <td>MTIOC7B and MTIOC7D</td> </tr> </tbody> </table> SPOER register setting being made 	MTU complementary PWM output pins		1	MTIOC3B and MTIOC3D	2	MTIOC4A and MTIOC4C	3	MTIOC4B and MTIOC4D	4	MTIOC6B and MTIOC6D	5	MTIOC7A and MTIOC7C	6	MTIOC7B and MTIOC7D
MTU complementary PWM output pins															
1	MTIOC3B and MTIOC3D														
2	MTIOC4A and MTIOC4C														
3	MTIOC4B and MTIOC4D														
4	MTIOC6B and MTIOC6D														
5	MTIOC7A and MTIOC7C														
6	MTIOC7B and MTIOC7D														
Function	<ul style="list-style-type: none"> Each of the POE0#, POE4#, POE8#, and POE10# input pins can be set for falling edge, $P0\phi/4 \times 16$, $P0\phi/16 \times 16$, or $P0\phi/128 \times 16$ low-level sampling. Pins for the MTU complementary PWM output, and MTU0 pin can be placed in high-impedance state by POE0#, POE4#, POE8#, and POE10# pin falling-edge or low-level sampling. Pins for the MTU complementary PWM output can be placed in high-impedance state when output levels of the MTU complementary PWM output pins are compared and simultaneous active-level output continues for one cycle or more. Pins for the MTU complementary PWM output, and MTU0 can be placed in the high-impedance state by modifying the settings of the SPOER register of POE3. Interrupts can be generated by input-level sampling or output level comparison results. 														

The POE3 has input level detection circuits, pin selection circuits, output level comparison circuits, and a high-impedance request/interrupt request generating circuit as shown in **Figure 17.1**.

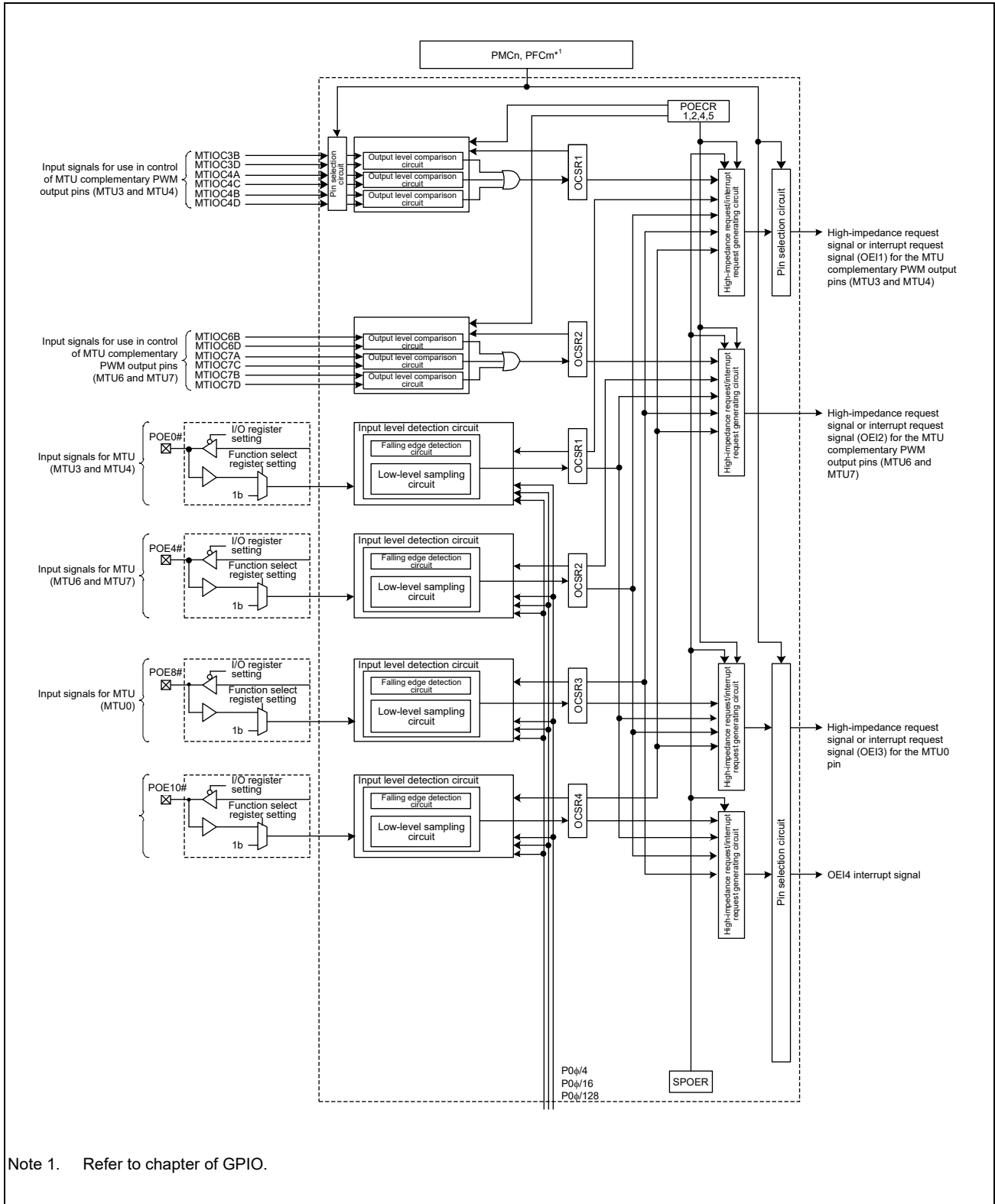

Figure 17.1 POE3 Block Diagram

Table 17.2 shows input/output pins to be used by the POE3.

Table 17.2 POE3 Input/Output Pins

Pin Name	I/O	Description
POE0#	Input	Input pin for the request signal to place the MTU3 and MTU4 pins for MTU complementary PWM output in high-impedance state. In accord with register settings, this pin is also capable of placing the MTU0, MTU6, and MTU7 pins in the high-impedance state.
POE4#	Input	Input pin for the request signal to place the MTU6 and MTU7 pins for MTU complementary PWM output in high-impedance state. In accord with register settings, this pin is also capable of placing the MTU0, MTU3, and MTU4 pins in the high-impedance state.
POE8#	Input	Input pin for the request signal to place the pins for MTU0 in high-impedance state. In accord with register settings, this pin is also capable of placing the MTU3 and MTU4 pins or MTU6 and MTU7 pins for MTU complementary PWM output in high-impedance state.
POE10#	Input	In accord with register settings, this pin is also capable of placing the MTU3 and MTU4 pins or MTU6 and MTU7 pins for MTU complementary PWM output, and MTU0 pins in high-impedance state.

Table 17.3 shows output level comparisons with pin combinations.

Table 17.3 Pin Combinations

Pin Combination	I/O	Description
MTIOC3B and MTIOC3D	Output	The MTU3 and MTU4 pins for MTU complementary PWM output set in the M3SELR, M4SELR1, and M4SELR2 registers are placed in high-impedance state when both pins of a pair simultaneously output the active level*1 for one or more cycles of the POE3_CLKM_POE (P0φ). Pin combinations for output comparison and high-impedance control can be selected by registers of POE3.
MTIOC4A and MTIOC4C	Output	
MTIOC4B and MTIOC4D	Output	
<p><i>Note 1.</i> The low level is output when the OLSP bit in TOCR1A of MTUn is 0 with the TOCS bit in TOCR1A of MTUn cleared to 0, or the high level is output when the OLSP bit is 1. Otherwise, the low level is output when the OLS3N, OLS3P, OLS2N, OLS2P, OLS1N, and OLS1P bits in TOCR2A of MTUn are 0 with the TOCS bit in TOCR1A of MTUn set to 1, or the high level is output when these bits are 1.</p>		
MTIOC6B and MTIOC6D	Output	The MTU6 and MTU7 pins for MTU complementary PWM output are placed in high-impedance state when both pins of a pair simultaneously output the active level*1 for one or more cycles of the POE3_CLKM_POE (P0φ). Pin combinations for output comparison and high-impedance control can be selected by registers of POE3.
MTIOC7A and MTIOC7C	Output	
MTIOC7B and MTIOC7D	Output	
<p><i>Note 1.</i> The low level is output when the OLSP bit in TOCR1B of MTUn is 0 with the TOCS bit in TOCR1B of MTUn cleared to 0, or the high level is output when the OLSP bit is 1. Otherwise, the low level is output when the OLS3N, OLS3P, OLS2N, OLS2P, OLS1N, and OLS1P bits in TOCR2B of MTUn are 0 with the TOCS bit in TOCR1B of MTUn set to 1, or the high level is output when these bits are 1.</p>		

17.2 Register Descriptions

Table 17.4 shows the register configuration. The POE3 registers are initialized by a reset.

Base Address: H'0_1004_9800 (AX45MP Address Space)

Table 17.4 Register configuration

Register Name	Abbreviation	Offset Address	Access size
Input level control/status register 1	ICSR1	H'00	16
Output level control/status register 1	OCSR1	H'02	16
Input level control/status register 2	ICSR2	H'04	16
Output level control/status register 2	OCSR2	H'06	16
Input level control/status register 3	ICSR3	H'08	16
Software port output enable register	SPOER	H'0A	8
Port output enable control register 1	POECR1	H'0B	8
Port output enable control register 2	POECR2	H'0C	16
Port output enable control register 4	POECR4	H'10	16
Port output enable control register 5	POECR5	H'12	16
Input level control/status register 4	ICSR4	H'16	16

17.2.1 Input Level Control/Status Register 1 (ICSR1)

ICSR1 selects the input modes for the POE0# pins, controls the enable/disable of interrupts, and indicates status.

Address(es): H'1004_9800

Bit	b15	b14	b13	b12	b11	b10	b9	b8	b7	b6	b5	b4	b3	b2	b1	b0
	—	—	—	POE0F	—	—	—	PIE1	—	—	—	—	—	—	POE0M[1:0]	
Initial Value	0	0	0	0	0	0	0	0	0	0	0	0	0	0	0	0
R/W	R/W	R/W	R/W	R/(W)*2	R/W	R/W	R/W	R/W	R/W	R/W	R/W	R/W	R/W	R/W	R/W*	R/W*

Bit	Bit Name	Initial Value	R/W	Description
b1, b0	POE0M[1:0]	All 0	R/W*	POE0 Mode Select b1 b0 0 0: Accepts a request on the falling edge of POE0# input. 0 1: Accepts a request when POE0# input has been sampled 16 times at P0φ/4 clock pulses and all are low level. 1 0: Accepts a request when POE0# input has been sampled 16 times at P0φ/16 clock pulses and all are low level. 1 1: Accepts a request when POE0# input has been sampled 16 times at P0φ/128 clock pulses and all are low level.
b7 to b2	—	All 0	R/W	Reserved These bits are read as 0. The write value should be 0.
b8	PIE1	0	R/W	Port Interrupt Enable 1 0: Interrupt requests disabled 1: Interrupt requests enabled
b11 to b9	—	All 0	R/W	Reserved These bits are read as 0. The write value should be 0.
b12	POE0F	0	R/(W)*2	POE0 Flag 0: Indicates that a high-impedance request has not been input to the POE0# pin. 1: Indicates that a high-impedance request has been input to the POE0# pin.
b15 to b13	—	All 0	R/W	Reserved These bits are read as 0. The write value should be 0.

Note 1. Can be modified only once after a reset. After the bits are modified once, writing these bits does not modify their values until the register is reset.

Note 2. Writing 0 to this bit after reading it as 1 clears the flag and is the only allowed way.

POE0M[1:0] Bits (POE0 Mode Select)

These bits select the input mode of the POE0# pin.

PIE1 Bit (Port Interrupt Enable 1)

This bit enables or disables interrupt requests when any one of the POE0F bit of the ICSR1 is set to 1.

POE0F Flag (POE0 Flag)

This flag indicates that a high-impedance request has been input to the POE0# pin.

[Setting condition]

- When the input set by POE0M[1:0] occurs at the POE0# pin

[Clearing condition]

- By writing 0 to POE0F after reading POE0F = 1

17.2.2 Input Level Control/Status Register 2 (ICSR2)

ICSR2 selects the input mode for the POE4# pin, controls the enable/disable of interrupts, and indicates status.

Address(es): H'1004_9804

Bit	b15	b14	b13	b12	b11	b10	b9	b8	b7	b6	b5	b4	b3	b2	b1	b0
	—	—	—	POE4F	—	—	—	PIE2	—	—	—	—	—	—	POE4M[1:0]	
Initial Value	0	0	0	0	0	0	0	0	0	0	0	0	0	0	0	0
R/W	R/W	R/W	R/W	R/(W)*2	R/W	R/W	R/W	R/W	R/W	R/W	R/W	R/W	R/W	R/W	R/W*	R/W*

Bit	Bit Name	Initial Value	R/W	Description
b1, b0	POE4M[1:0]	All 0	R/W*	POE4 Mode Select b1 b0 0 0: Accepts a request on the falling edge of POE4# input 0 1: Accepts a request when POE4# input has been sampled 16 times at P0φ/4 clock pulses and all are low level. 1 0: Accepts a request when POE4# input has been sampled 16 times at P0φ/16 clock pulses and all are low level. 1 1: Accepts a request when POE4# input has been sampled 16 times at P0φ/128 clock pulses and all are low level.
b7 to b2	—	All 0	R/W	Reserved These bits are read as 0. The write value should be 0.
b8	PIE2	0	R/W	Port Interrupt Enable 2 0: Interrupt requests disabled 1: Interrupt requests enabled
b11 to b9	—	All 0	R/W	Reserved These bits are read as 0. The write value should be 0.
b12	POE4F	0	R/(W)*2	POE4 Flag 0: Indicates that a high-impedance request has not been input to the POE4# pin. 1: Indicates that a high-impedance request has been input to the POE4# pin.
b15 to b13	—	All 0	R/W	Reserved These bits are read as 0. The write value should be 0.

Note 1. Can be modified only once after a reset. After the bits are modified once, writing these bits does not modify their values until the register is reset.

Note 2. Writing 0 to this bit after reading it as 1 clears the flag and is the only allowed way.

POE4M[1:0] Bits (POE4 Mode Select)

These bits select the input mode of the POE4# pin.

PIE2 Bit (Port Interrupt Enable 2)

This bit enables or disables interrupt requests when the POE4F flag in ICSR2 is set to 1.

POE4F Flag (POE4 Flag)

This flag indicates that a high-impedance request has been input to the POE4# pin.

[Setting condition]

- When the input set by POE4M[1:0] occurs at the POE4# pin

[Clearing condition]

- By writing 0 to POE4F after reading POE4F = 1

17.2.3 Input Level Control/Status Register 3 (ICSR3)

ICSR3 selects the input mode for the POE8# pin, controls the enable/disable of interrupts, and indicates status.

Address(es): H'1004_9808

Bit	b15	b14	b13	b12	b11	b10	b9	b8	b7	b6	b5	b4	b3	b2	b1	b0
	—	—	—	POE8F	—	—	POE8E	PIE3	—	—	—	—	—	—	POE8M[1:0]	
Initial Value	0	0	0	0	0	0	0	0	0	0	0	0	0	0	0	0
R/W	R/W	R/W	R/W	R/(W)*2	R/W	R/W	R/W*1	R/W	R/W	R/W	R/W	R/W	R/W	R/W	R/W*1	R/W*1

Bit	Bit Name	Initial Value	R/W	Description
b1, b0	POE8M[1:0]	All 0	R/W*1	POE8 Mode Select b1 b0 0 0: Accepts a request on the falling edge of POE8# input 0 1: Accepts a request when POE8# input has been sampled 16 times at P0φ/4 clock pulses and all are low level. 1 0: Accepts a request when POE8# input has been sampled 16 times at P0φ/16 clock pulses and all are low level. 1 1: Accepts a request when POE8# input has been sampled 16 times at P0φ/128 clock pulses and all are low level.
b7 to b2	—	All 0	R/W	Reserved These bits are read as 0. The write value should be 0.
b8	PIE3	0	R/W	Port Interrupt Enable 3 0: Interrupt requests disabled 1: Interrupt requests enabled
b9	POE8E	0	R/W*1	POE8 High- Impedance Enable 0: Does not place the pin in high-impedance state. 1: Places the pin in high-impedance state.
b11, b10	—	All 0	R/W	Reserved These bits are read as 0. The write value should be 0.
b12	POE8F	0	R/(W) *2	POE8 Flag 0: Indicates that a high-impedance request has not been input to the POE8# pin. 1: Indicates that a high-impedance request has been input to the POE8# pin.
b15 to b13	—	All 0	R/W	Reserved These bits are read as 0. The write value should be 0.

Note 1. Can be modified only once after a reset. After the bits are modified once, writing these bits does not modify their values until the register is reset.

Note 2. Writing 0 to this bit after reading it as 1 clears the flag and is the only allowed way.

POE8M[1:0] Bits (POE8 Mode Select)

These bits select the input mode of the POE8# pin.

PIE3 Bit (Port Interrupt Enable 3)

This bit enables or disables interrupt requests when the POE8F bit in ICSR3 is set to 1.

POE8E Bit (POE8 High-Impedance Enable)

This bit specifies whether to place the corresponding pin in high-impedance state when the POE8F bit is set to 1.

POE8F Flag (POE8 Flag)

This flag indicates that a high-impedance request has been input to the POE8# pin.

[Setting condition]

- When the input set by POE8M[1:0] occurs at the POE8# pin

[Clearing condition]

- By writing 0 to POE8F after reading POE8F = 1

17.2.4 Input Level Control/Status Register 4 (ICSR4)

ICSR4 selects the POE10# pin input mode, controls the enable/disable of interrupts, and indicates status.

Address(es): H'1004_9816

Bit	b15	b14	b13	b12	b11	b10	b9	b8	b7	b6	b5	b4	b3	b2	b1	b0
	—	—	—	POE10F	—	—	POE10E	PIE4	—	—	—	—	—	—	POE10M[1:0]	
Initial Value	0	0	0	0	0	0	0	0	0	0	0	0	0	0	0	0
R/W	R/W	R/W	R/W	R/(W)*2	R/W	R/W	R/W*1	R/W*1	R/W	R/W	R/W	R/W	R/W	R/W	R/W*1	R/W*1

Bit	Bit Name	Initial Value	R/W	Description
b1, b0	POE10M[1:0]	All 0	R/W*1	POE10 Mode Select b1 b0 0 0: Accepts a request on the falling edge of POE10# input 0 1: Accepts a request when POE10# input has been sampled 16 times at P0φ/4 clock pulses and all are low level. 1 0: Accepts a request when POE10# input has been sampled 16 times at P0φ/16 clock pulses and all are low level. 1 1: Accepts a request when POE10# input has been sampled 16 times at P0φ/128 clock pulses and all are low level.
b7 to b2	—	All 0	R/W	Reserved These bits are read as 0. The write value should be 0.
b8	PIE4	0	R/W	Port Interrupt Enable 4 0: Interrupt requests disabled 1: Interrupt requests enabled
b9	POE10E	0	R/W*1	POE10 High- Impedance Enable 0: Does not place the pin in high-impedance state. 1: Places the pin in high-impedance state.
b11, b10	—	All 0	R/W	Reserved These bits are read as 0. The write value should be 0.
b12	POE10F	0	R/(W) *2	POE10 Flag 0: Indicates that a high-impedance request has not been input to the POE10# pin. 1: Indicates that a high-impedance request has been input to the POE10# pin.
b15 to b13	—	All 0	R/W	Reserved These bits are read as 0. The write value should be 0.

Note 1. Can be modified only once after a reset. After the bits are modified once, writing these bits does not modify their values until the register is reset.

Note 2. Writing 0 to this bit after reading it as 1 clears the flag and is the only allowed way.

POE10M[1:0] Bits (POE10 Mode Select)

These bits select the input mode of the POE10# pin.

PIE4 Bit (Port Interrupt Enable 4)

This bit enables or disables interrupt requests when the POE10F bit is set to 1.

POE10E Bit (POE10 High-Impedance Enable)

This bit specifies whether to place the corresponding pin in high-impedance state when the POE10F bit is set to 1.

POE10F Bit (POE10 Flag)

This flag indicates that a request for the high-impedance state has been input to the POE10# pin.

[Setting condition]

- When the input set by POE10M[1:0] occurs at the POE10# pin

[Clearing condition]

- By writing 0 to POE10F after reading POE10F = 1

17.2.5 Output Level Control/Status Register 1 (OCSR1)

OCSR1 controls the enable/disable of output level comparison and interrupts, and indicates status.

Address(es): H'1004_9802

Bit	b15	b14	b13	b12	b11	b10	b9	b8	b7	b6	b5	b4	b3	b2	b1	b0
	OSF1	—	—	—	—	—	OCE1	OIE1	—	—	—	—	—	—	—	—
Initial Value	0	0	0	0	0	0	0	0	0	0	0	0	0	0	0	0
R/W	R/(W)*2	R/W	R/W	R/W	R/W	R/W	R/W*1	R/W	R/W	R/W	R/W	R/W	R/W	R/W	R/W	R/W

Bit	Bit Name	Initial Value	R/W	Description
b7 to b0	—	All 0	R/W	Reserved These bits are read as 0. The write value should be 0.
b8	OIE1	0	R/W	Output Short Interrupt Enable 1 0: Interrupt requests disabled 1: Interrupt requests enabled
b9	OCE1	0	R/W*1	Output Short High-Impedance Enable 1 0: Does not place the pins in high-impedance state. 1: Places the pins in high-impedance state.
b14 to b10	—	All 0	R/W	Reserved These bits are read as 0. The write value should be 0.
b15	OSF1	0	R/(W) *2	Output Short Flag 1 0: Indicates that outputs have not simultaneously become an active level. 1: Indicates that outputs have simultaneously become an active level.

Note 1. Can be modified only once after a reset. After the bit is modified once, writing this bit does not modify its value until the register is reset.

Note 2. Writing 0 to this bit after reading it as 1 clears the flag and is the only allowed way.

OIE1 Bit (Output Short Interrupt Enable 1)

This bit enables or disables interrupt requests when the OSF1 bit in OCSR1 is set to 1.

OCE1 Bit (Output Short High-Impedance Enable 1)

This bit specifies whether to place the pins in high-impedance state when the OSF1 bit in OCSR1 is set to 1.

OSF1 Flag (Output Short Flag 1)

This flag indicates that any one of the three pairs of two-phase MTU3 and MTU4 pins for MTU complementary PWM output to be compared has simultaneously become an active level.

[Setting condition]

- When any one of the three pairs of two-phase outputs has simultaneously become an active level

[Clearing condition]

- By writing 0 to OSF1 after reading OSF1 = 1

17.2.6 Output Level Control/Status Register 2 (OCSR2)

OCSR2 controls the enable/disable of output level comparison and interrupts, and indicates status.

Address(es): H'1004_9806

Bit	b15	b14	b13	b12	b11	b10	b9	b8	b7	b6	b5	b4	b3	b2	b1	b0
	OSF2	—	—	—	—	—	OCE2	OIE2	—	—	—	—	—	—	—	—
Initial Value	0	0	0	0	0	0	0	0	0	0	0	0	0	0	0	0
R/W	R/(W)*2	R/W	R/W	R/W	R/W	R/W	R/W*1	R/W	R/W	R/W	R/W	R/W	R/W	R/W	R/W	R/W

Bit	Bit Name	Initial Value	R/W	Description
b7 to b0	—	All 0	R/W	Reserved These bits are read as 0. The write value should be 0.
b8	OIE2	0	R/W	Output Short Interrupt Enable 2 0: Interrupt requests disabled 1: Interrupt requests enabled
b9	OCE2	0	R/W*1	Output Short High-Impedance Enable 2 0: Does not place the pins in high-impedance state. 1: Places the pins in high-impedance state.
b14 to b10	—	All 0	R/W	Reserved These bits are read as 0. The write value should be 0.
b15	OSF2	0	R/(W) *2	Output Short Flag 2 0: Indicates that outputs have not simultaneously become an active level. 1: Indicates that outputs have simultaneously become an active level.

Note 1. Can be modified only once after a reset. After the bit is modified once, writing this bit does not modify its value until the register is reset.

Note 2. Writing 0 to this bit after reading it as 1 clears the flag and is the only allowed way.

OIE2 Bit (Output Short Interrupt Enable 2)

This bit enables or disables interrupt requests when the OSF2 bit in OCSR2 is set to 1.

OCE2 Bit (Output Short High-Impedance Enable 2)

This bit specifies whether to place the pins in high-impedance state when the OSF2 bit in OCSR2 is set to 1.

OSF2 Flag (Output Short Flag 2)

This flag indicates that any one of the three pairs of two-phase MTU6 and MTU7 pins for MTU complementary PWM output to be compared has simultaneously become an active level.

[Setting condition]

- When any one of the three pairs of two-phase outputs has simultaneously become an active level

[Clearing condition]

- By writing 0 to OSF2 after reading OSF2 = 1

17.2.7 Software Port Output Enable Register (SPOER)

SPOER controls high-impedance state of the pins.

Address(es): H'1004_980A

Bit	b7	b6	b5	b4	b3	b2	b1	b0
	—	—	—	—	—	MTUCH0HIZ	MTUCH67HIZ	MTUCH34HIZ
Initial Value	0	0	0	0	0	0	0	0
R/W	R/W	R/W	R/W	R/W	R/W	R/W	R/W	R/W

Bit	Bit Name	Initial Value	R/W	Description
b0	MTUCH34HIZ	0	R/W	MTU3 or MTU4 Output High-Impedance Enable 0: Does not place the pins in high-impedance state. 1: Places the pins in high-impedance state.
b1	MTUCH67HIZ	0	R/W	MTU6 and MTU7 Output High-Impedance Enable 0: Does not place the pins in high-impedance state. 1: Places the pins in high-impedance state.
b2	MTUCH0HIZ	0	R/W	MTU0 Output High-Impedance Enable 0: Does not place the pins in high-impedance state. 1: Places the pins in high-impedance state.
b7 to b3	—	All 0	R/W	Reserved These bits are read as 0. The write value should be 0.

MTUCH34HIZ Bit (MTU3 or MTU4 Output High-Impedance Enable)

This bit specifies whether to place the MTU complementary PWM output pins (MTIOC3B, MTIOC3D, MTIOC4A, MTIOC4B, MTIOC4C, MTIOC4D) in high-impedance state.

[Setting condition]

- By writing 1 to MTUCH34HIZ

[Clearing conditions]

- Reset
- By writing 0 to MTUCH34HIZ after reading MTUCH34HIZ = 1*¹

Note 1. To write 0 to this bit, be sure to read 1 and then write 0.

MTUCH67HIZ Bit (MTU6 and MTU7 Output High-Impedance Enable)

This bit specifies whether to place the MTU complementary PWM output pins (MTIOC6B, MTIOC6D, MTIOC7A, MTIOC7B, MTIOC7C, and MTIOC7D) in high-impedance state.

[Setting condition]

- By writing 1 to MTUCH67HIZ

[Clearing conditions]

- Reset
- By writing 0 to MTUCH67HIZ after reading MTUCH67HIZ = 1*¹

Note 1. To write 0 to this bit, be sure to read 1 and then write 0.

MTUCH0HIZ Bit (MTU0 Output High-Impedance Enable)

This bit specifies whether to place the MTU0 pins in high-impedance state.

[Setting condition]

- By writing 1 to MTUCH0HIZ

[Clearing conditions]

- Reset
- By writing 0 to MTUCH0HIZ after reading MTUCH0HIZ = 1*¹

Note 1. To write 0 to this bit, be sure to read 1 and then write 0.

17.2.8 Port Output Enable Control Register 1 (POECR1)

POECR1 controls high-impedance state of the MTU0 pins.

Address(es): H'1004_980B

Bit	b7	b6	b5	b4	b3	b2	b1	b0
	—	—	—	—	MTU0D ZE	MTU0C ZE	MTU0B ZE	MTU0A ZE
Initial Value	0	0	0	0	0	0	0	0
R/W	R/W	R/W	R/W	R/W	R/W*1	R/W*1	R/W*1	R/W*1

Bit	Bit Name	Initial Value	R/W	Description
b0	MTU0AZE	0	R/W*1	MTIOC0A High-Impedance Enable 0: Does not place the pin in high-impedance state. 1: Places the pin in high-impedance state.
b1	MTU0BZE	0	R/W*1	MTIOC0B High-Impedance Enable 0: Does not place the pin in high-impedance state. 1: Places the pin in high-impedance state.
b2	MTU0CZE	0	R/W*1	MTIOC0C High-Impedance Enable 0: Does not place the pin in high-impedance state. 1: Places the pin in high-impedance state.
b3	MTU0DZE	0	R/W*1	MTIOC0D High-Impedance Enable 0: Does not place the pin in high-impedance state. 1: Places the pin in high-impedance state.
b7 to b4	—	All 0	R/W	Reserved These bits are read as 0. The write value should be 0.

Note 1. Can be modified only once after a reset. After the bit is modified once, writing this bit does not modify its value until the register is reset.

MTU0AZE Bit (MTIOC0A High-Impedance Enable)

This bit specifies whether to place the MTIOC0A output for the MTU0 pin in high-impedance state when any of the POE8F flag in ICSR3, MTUCH0HIZ bit in SPOER or, as additionally specified in POECR5, the POEmF (n = 1, 2, 4; m = 0, 4, 10) flag in ICSRn, is set to 1.

MTU0BZE Bit (MTIOC0B High-Impedance Enable)

This bit specifies whether to place the MTIOC0B output for the MTU0 pin in high-impedance state when any of the POE8F flag in ICSR3, MTUCH0HIZ bit in SPOER or, as additionally specified in POECR5, the POEmF (n = 1, 2, 4; m = 0, 4, 10) flag in ICSRn, is set to 1.

MTU0CZE Bit (MTIOC0C High-Impedance Enable)

This bit specifies whether to place the MTIOC0C output for the MTU0 pin in high-impedance state when any of the POE8F flag in ICSR3, MTUCH0HIZ bit in SPOER or, as additionally specified in POECR5, the POEmF (n = 1, 2, 4; m = 0, 4, 10) flag in ICSRn, is set to 1.

MTU0DZE Bit (MTIOC0D High-Impedance Enable)

This bit specifies whether to place the MTIOC0D output for the MTU0 pin in high-impedance state when any of the POE8F flag in ICSR3, MTUCH0HIZ bit in SPOER or, as additionally specified in POECR5, the POEmF (n = 1, 2, 4; m = 0, 4, 10) flag in ICSRn, is set to 1.

17.2.9 Port Output Enable Control Register 2 (POECR2)

POECR2 controls high-impedance state of the MTU complementary PWM output pins (MTU3, MTU4, MTU6, and MTU7 pins).

Address(es): H'1004_980C

Bit	b15	b14	b13	b12	b11	b10	b9	b8	b7	b6	b5	b4	b3	b2	b1	b0
	—	—	—	—	—	MTU3B DZE	MTU4A CZE	MTU4B DZE	—	—	—	—	—	MTU6B DZE	MTU7A CZE	MTU7B DZE
Initial Value	0	0	0	0	0	1	1	1	0	0	0	0	0	1	1	1
R/W	R/W	R/W	R/W	R/W	R/W	R/W*1	R/W*1	R/W*1	R/W	R/W	R/W	R/W	R/W	R/W*1	R/W*1	R/W*1

Bit	Bit Name	Initial Value	R/W	Description
b0	MTU7BDZE	1	R/W*1	MTIOC7B/7D High-Impedance Enable*2 0: Does not place the pins in high-impedance state. 1: Places the pins in high-impedance state.
b1	MTU7ACZE	1	R/W*1	MTIOC7A/7C High-Impedance Enable*2 0: Does not place the pins in high-impedance state. 1: Places the pins in high-impedance state.
b2	MTU6BDZE	1	R/W*1	MTIOC6B/6D High-Impedance Enable*2 0: Does not place the pins in high-impedance state. 1: Places the pins in high-impedance state.
b7 to b3	—	All 0	R/W	Reserved These bits are read as 0. The write value should be 0.
b8	MTU4BDZE	1	R/W*1	MTIOC4B/4D High-Impedance Enable 0: Does not place the pins in high-impedance state. 1: Places the pins in high-impedance state.
b9	MTU4ACZE	1	R/W*1	MTIOC4A/4C High-Impedance Enable 0: Does not place the pins in high-impedance state. 1: Places the pins in high-impedance state.
b10	MTU3BDZE	1	R/W*1	MTIOC3B/3D High-Impedance Enable 0: Does not place the pins in high-impedance state. 1: Places the pins in high-impedance state.
b15 to b11	—	All 0	R/W	Reserved These bits are read as 0. The write value should be 0.

Note 1. Can be modified only once after a reset. After the bit is modified once, writing this bit does not modify its value until the register is reset.

Note 2. Set this bit to 0 when MTU6 or MTU7 is not used.

MTU7BDZE Bit (MTIOC7B/7D High-Impedance Enable)

This bit specifies whether to place the MTIOC7B output and MTIOC7D output for the MTU3 pin in high-impedance state when any one of the OSF2 flag in OCSR2, POE4F flag in ICSR2, MTUCH67HIZ bit in SPOER, OSTSTF flag in ICSR6 (when the OSTSTE bit is 1), or, as additionally specified in POECR4, the POEmF (n = 1, 3, 4; m = 0, 8, 10) flag in ICSRn, is set to 1.

MTU7ACZE Bit (MTIOC7A/7C High-Impedance Enable)

This bit specifies whether to place the MTIOC7A output and MTIOC7C output for the MTU3 pin in high-impedance state when any one of the OSF2 flag in OCSR2, POE4F flag in ICSR2, MTUCH67HIZ bit in SPOER, OSTSTF flag in ICSR6 (when the OSTSTE bit is 1), or, as additionally specified in POECR4, the POEmF (n = 1, 3, 4; m = 0, 8, 10) flag in ICSRn, is set to 1.

MTU6BDZE Bit (MTIOC6B/6D High-Impedance Enable)

This bit specifies whether to place the MTIOC6B output and MTIOC6D output for the MTU3 pin in high-impedance state when any one of the OSF2 flag in OCSR2, POE4F flag in ICSR2, MTUCH67HIZ bit in SPOER, OSTSTF flag in ICSR6 (when the OSTSTE bit is 1), or, as additionally specified in POECR4, the POEmF (n = 1, 3, 4; m = 0, 8, 10) flag in ICSRn, is set to 1.

MTU4BDZE Bit (MTIOC4B/4D High-Impedance Enable)

This bit specifies whether to place the MTIOC4B output and MTIOC4D output for the MTU4 pin in high-impedance state when any one of the OSF1 flag in OCSR1, POE0F flag in ICSR1, MTUCH34HIZ bit in SPOER, OSTSTF flag in ICSR6 (when the OSTSTE bit is 1), or, as additionally specified in POECR4, the POEmF (n = 2 to 4; m = 4, 8, 10) flag in ICSRn, is set to 1.

MTU4ACZE Bit (MTIOC4A/4C High-Impedance Enable)

This bit specifies whether to place the MTIOC4A output and MTIOC4C output for the MTU4 pin in high-impedance state when any one of the OSF1 flag in OCSR1, POE0F flag in ICSR1, MTUCH34HIZ bit in SPOER, OSTSTF flag in ICSR6 (when the OSTSTE bit is 1), or, as additionally specified in POECR4, the POEmF (n = 2 to 4; m = 4, 8, 10) flag in ICSRn, is set to 1.

MTU3BDZE Bit (MTIOC3B/3D High-Impedance Enable)

This bit specifies whether to place the MTIOC3B output and MTIOC3D output for the MTU3 pin in high-impedance state when any one of the OSF1 flag in OCSR1, POE0F flag in ICSR1, MTUCH34HIZ bit in SPOER, OSTSTF flag in ICSR6 (when the OSTSTE bit is 1), or, as additionally specified in POECR4, the POEmF (n = 2 to 4; m = 4, 8, 10) flag in ICSRn, is set to 1.

17.2.10 Port Output Enable Control Register 4 (POECR4)

The POECR4 is used to extend the control conditions of the high-impedance state for the MTU3, MTU4, MTU6, and MTU7 pins for the MTU complementary PWM output.

For details about the targets and conditions of high-impedance control, see **Figure 17.2**.

Address(es): H'1004_9810

Bit	b15	b14	b13	b12	b11	b10	b9	b8	b7	b6	b5	b4	b3	b2	b1	b0
	—	—	—	IC4ADD MT67	IC3ADD MT67	—	IC1ADD MT67	—	—	—	—	IC4ADD MT34	IC3ADD MT34	IC2ADD MT34	—	—
Initial Value	0	0	0	0	0	1	0	0	0	0	0	0	0	0	1	0
	R/W	R/W	R/W	R/W*	R/W*	R/W	R/W*	R/W	R/W	R/W	R/W	R/W*	R/W*	R/W*	R/W	R/W

Bit	Bit Name	Initial Value	R/W	Description
b0	—	0	R/W	Reserved This bit is read as 0. The write value should be 0.
b1	—	1	R/W	Reserved This bit is read as 1. The write value should be 1.
b2	IC2ADDMT34 ZE	0	R/W*	MTU3 and MTU4 High- Impedance POE4F Add 0: Does not add the pins to the high-impedance control conditions. 1: Adds the pins to the high-impedance control conditions.
b3	IC3ADDMT34 ZE	0	R/W*	MTU3 and MTU4 High- Impedance POE8F Add 0: Does not add the pins to the high-impedance control conditions. 1: Adds the pins to the high-impedance control conditions.
b4	IC4ADDMT34 ZE	0	R/W*	MTU3 and MTU4 High- Impedance POE10F Add 0: Does not add the pins to the high-impedance control conditions. 1: Adds the pins to the high-impedance control conditions.
b8 to b5	—	All 0	R/W	Reserved These bits are read as 0. The write value should be 0
b9	IC1ADDMT67 ZE	0	R/W*	MTU6 and MTU7 High- Impedance POE0F Add 0: Does not add the pins to the high-impedance control conditions. 1: Adds the pins to the high-impedance control conditions.
b10	—	1	R/W	Reserved This bit is read as 1. The write value should be 1.
b11	IC3ADDMT67 ZE	0	R/W*	MTU6 and MTU7 High- Impedance POE8F Add 0: Does not add the pins to the high-impedance control conditions. 1: Adds the pins to the high-impedance control conditions.
b12	IC4ADDMT67 ZE	0	R/W*	MTU6 and MTU7 High- Impedance POE10F Add 0: Does not add the pins to the high-impedance control conditions. 1: Adds the pins to the high-impedance control conditions.
b15 to b13	—	All 0	R/W	Reserved These bits are read as 0. The write value should be 0.

Note 1. Can be modified only once after a reset. After the bit is modified once, writing this bit does not modify its value until the register is reset.

IC2ADDMT34ZE Bit (MTU3 and MTU4 High-Impedance POE4F Add)

Adds the POE4F flag in ICSR2 (POE4#) to the high-impedance control conditions for the MTU3 and MTU4 pins (MTIOC3B/MTIOC3D/MTIOC4A/MTIOC4C/MTIOC4B/MTIOC4D).

IC3ADDMT34ZE Bit (MTU3 and MTU4 High-Impedance POE8F Add)

Adds the POE8F flag in ICSR3 (POE8#) to the high-impedance control conditions for the MTU3 and MTU4 pins (MTIOC3B/MTIOC3D/MTIOC4A/MTIOC4C/MTIOC4B/MTIOC4D).

IC4ADDMT34ZE Bit (MTU3 and MTU4 High-Impedance POE10F Add)

Adds the POE10F flag in ICSR4 (POE10#) to the high-impedance control conditions for the MTU3 and MTU4 pins (MTIOC3B/MTIOC3D/MTIOC4A/MTIOC4C/MTIOC4B/MTIOC4D).

IC1ADDMT67ZE Bit (MTU6 and MTU7 High-Impedance POE0F Add)

Adds the POE0F flag in ICSR1 (POE0#) to the high-impedance control conditions for the MTU6, and MTU7 pins (MTIOC6B/MTIOC6D/MTIOC7A/MTIOC7C/MTIOC7B/MTIOC7D).

IC3ADDMT67ZE Bit (MTU6 and MTU7 High-Impedance POE8F Add)

Adds the POE8F flag in ICSR3 (POE8#) to the high-impedance control conditions for the MTU6, and MTU7 pins (MTIOC6B/MTIOC6D/MTIOC7A/MTIOC7C/MTIOC7B/MTIOC7D).

IC4ADDMT67ZE Bit (MTU6 and MTU7 High-Impedance POE10F Add)

Adds the POE10F flag in ICSR4 (POE10#) to the high-impedance control conditions for the MTU6, and MTU7 pins (MTIOC6B/MTIOC6D/MTIOC7A/MTIOC7C/MTIOC7B/MTIOC7D).

17.2.11 Port Output Enable Control Register 5 (POECR5)

The POECR5 is used to extend the control conditions of the high-impedance for the MTU0 pin.

For details about the targets and conditions of high-impedance control, see **Figure 17.2**.

Address(es): H'1004_9812

Bit	b15	b14	b13	b12	b11	b10	b9	b8	b7	b6	b5	b4	b3	b2	b1	b0
	—	—	—	—	—	—	—	—	—	—	—	IC4ADD MT0ZE	—	IC2ADD MT0ZE	IC1ADD MT0ZE	—
Initial Value	0	0	0	0	0	0	0	0	0	0	0	0	1	0	0	0
	R/W	R/W	R/W	R/W	R/W	R/W	R/W	R/W	R/W	R/W	R/W	R/W*	R/W	R/W*	R/W*	R/W

Bit	Bit Name	Initial Value	R/W	Description
b0	—	0	R/W	Reserved This bit is read as 0. The write value should be 0.
b1	IC1ADDMT0ZE	0	R/W*	MTU0 High-Impedance POE0F Add 0: Does not add the pins to the high-impedance control conditions. 1: Adds the pins to the high-impedance control conditions.
b2	IC2ADDMT0ZE	0	R/W*	MTU0 High-Impedance POE4F Add 0: Does not add the pins to the high-impedance control conditions. 1: Adds the pins to the high-impedance control conditions.
b3	—	1	R/W	Reserved This bit is read as 1. The write value should be 1.
b4	IC4ADDMT0ZE	0	R/W*	MTU0 High-Impedance POE10F Add 0: Does not add the pins to the high-impedance control conditions. 1: Adds the pins to the high-impedance control conditions.
b15 to b5	—	All 0	R/W	Reserved These bits are read as 0. The write value should be 0.

Note 1. Can be modified only once after a reset. After the bit is modified once, writing this bit does not modify its value until the register is reset.

IC1ADDMT0ZE Bit (MTU0 High-Impedance POE0F Add)

Adds the POE0F flag in ICSR1 (POE0#) to the high-impedance control conditions for the MTU0 pins (MTIOC0A, MTIOC0B, MTIOC0C, MTIOC0D).

IC2ADDMT0ZE Bit (MTU0 High-Impedance POE4F Add)

Adds the POE4F flag in ICSR2 (POE4#) to the high-impedance control conditions for the MTU0 pins (MTIOC0A, MTIOC0B, MTIOC0C, MTIOC0D).

IC4ADDMT0ZE Bit (MTU0 High-Impedance POE10F Add)

Adds the POE10F flag in ICSR4 (POE10#) to the high-impedance control conditions for the MTU0 pins (MTIOC0A, MTIOC0B, MTIOC0C, MTIOC0D).

17.3 Operation

Table 17.5 shows the target pins for high-impedance control and conditions to place the pins in high-impedance state.

Table 17.5 Target Pins and Conditions for High-Impedance Control (1/2)

Pins	Conditions	Detailed Conditions
MTU3 pins (MTIOC3B and MTIOC3D)	<ul style="list-style-type: none"> • Operation for detection of the POE0# input level • Operation for comparison of the output levels on the MTIOC3B and MTIOC3D pins • SPOER setting • Additional conditions of the POECR4 	MTU3BDZE• ((POE0F) +(OSF1•OCE1) +(MTUCH34HIZ) +(IC2ADDMT34ZE•POE4F) +(IC3ADDMT34ZE•POE8E•POE8F) +(IC4ADDMT34ZE•ICSR4.POE10E•ICSR4.POE10F)
MTU4 pins (MTIOC4A and MTIOC4C)	<ul style="list-style-type: none"> • Operation for detection of the POE0# input level • Operation for comparison of the output levels on the MTIOC4A and MTIOC4C pins • SPOER setting • Additional conditions of the POECR4 	MTU4ACZE• ((POE0F) +(OSF1•OCE1) +(MTUCH34HIZ) +(IC2ADDMT34ZE•POE4F) +(IC3ADDMT34ZE•POE8E•POE8F) +(IC4ADDMT34ZE•ICSR4.POE10E•ICSR4.POE10F)
MTU4 pins (MTIOC4B and MTIOC4D)	<ul style="list-style-type: none"> • Operation for detection of the POE0# input level • Operation for comparison of the output levels on the MTIOC4B and MTIOC4D pins • SPOER setting • Additional conditions of the POECR4 	MTU4BDZE• ((POE0F) +(OSF1•OCE1) +(MTUCH34HIZ) +(IC2ADDMT34ZE•POE4F) +(IC3ADDMT34ZE•POE8E•POE8F) +(IC4ADDMT34ZE•ICSR4.POE10E•ICSR4.POE10F)
MTU6 pins (MTIOC6B and MTIOC6D)	<ul style="list-style-type: none"> • Operation for detection of the POE4# input level • Operation for comparison of the output levels on the MTIOC6B and MTIOC6D pins • SPOER setting • Additional conditions of the POECR4 	MTU6BDZE• ((POE4F) +(OSF2•OCE2) +(MTUCH67HIZ) +(IC1ADDMT67ZE•POE0F) +(IC3ADDMT67ZE•POE8E•POE8F) +(IC4ADDMT67ZE•ICSR4.POE10E•ICSR4.POE10F)
MTU7 pins (MTIOC7A and MTIOC7C)	<ul style="list-style-type: none"> • Operation for detection of the POE4# input level • Operation for comparison of the output levels on the MTIOC7A and MTIOC7C pins • SPOER setting • Additional conditions of the POECR4 	MTU7ACZE• ((POE4F) +(OSF2•OCE2) +(MTUCH67HIZ) +(IC1ADDMT67ZE•POE0F) +(IC3ADDMT67ZE•POE8E•POE8F) +(IC4ADDMT67ZE•ICSR4.POE10E•ICSR4.POE10F)
MTU7 pins (MTIOC7B and MTIOC7D)	<ul style="list-style-type: none"> • Operation for detection of the POE4# input level • Operation for comparison of the output levels on the MTIOC7B and MTIOC7D pins • SPOER setting • Additional conditions of the POECR4 	MTU7BDZE• ((POE4F) +(OSF2•OCE2) +(MTUCH67HIZ) +(IC1ADDMT67ZE•POE0F) +(IC3ADDMT67ZE•POE8E•POE8F) +(IC4ADDMT67ZE•ICSR4.POE10E•ICSR4.POE10F)
MTU0 pin (MTIOC0A)	<ul style="list-style-type: none"> • Operation for detection of the POE8# input level • SPOER setting • Additional conditions of the POECR5 	MTU0AZE• ((POE8F•POE8E) +(MTUCH0HIZ) +(IC1ADDMT0ZE•POE0F) +(IC2ADDMT0ZE•POE4F) +(IC4ADDMT0ZE•ICSR4.POE10E•ICSR4.POE10F)

Table 17.5 Target Pins and Conditions for High-Impedance Control (2/2)

Pins	Conditions	Detailed Conditions
MTU0 pin (MTIOC0B)	<ul style="list-style-type: none"> • Operation for detection of the POE8# input level • SPOER setting • Additional conditions of the POECSR5 	$MTU0BZE \cdot ((POE8F \cdot POE8E) + (MTUCH0HIZ) + (IC1ADDMT0ZE \cdot POE0F) + (IC2ADDMT0ZE \cdot POE4F) + (IC4ADDMT0ZE \cdot ICSR4.POE10E \cdot ICSR4.POE10F))$
MTU0 pin (MTIOC0C)	<ul style="list-style-type: none"> • Operation for detection of the POE8# input level • SPOER setting • Additional conditions of the POECSR5 	$MTU0CZE \cdot ((POE8F \cdot POE8E) + (MTUCH0HIZ) + (IC1ADDMT0ZE \cdot POE0F) + (IC2ADDMT0ZE \cdot POE4F) + (IC4ADDMT0ZE \cdot ICSR4.POE10E \cdot ICSR4.POE10F))$
MTU0 pin (MTIOC0D)	<ul style="list-style-type: none"> • Operation for detection of the POE8# input level • SPOER setting • Additional conditions of the POECSR5 	$MTU0DZE \cdot ((POE8F \cdot POE8E) + (MTUCH0HIZ) + (IC1ADDMT0ZE \cdot POE0F) + (IC2ADDMT0ZE \cdot POE4F) + (IC4ADDMT0ZE \cdot ICSR4.POE10E \cdot ICSR4.POE10F))$

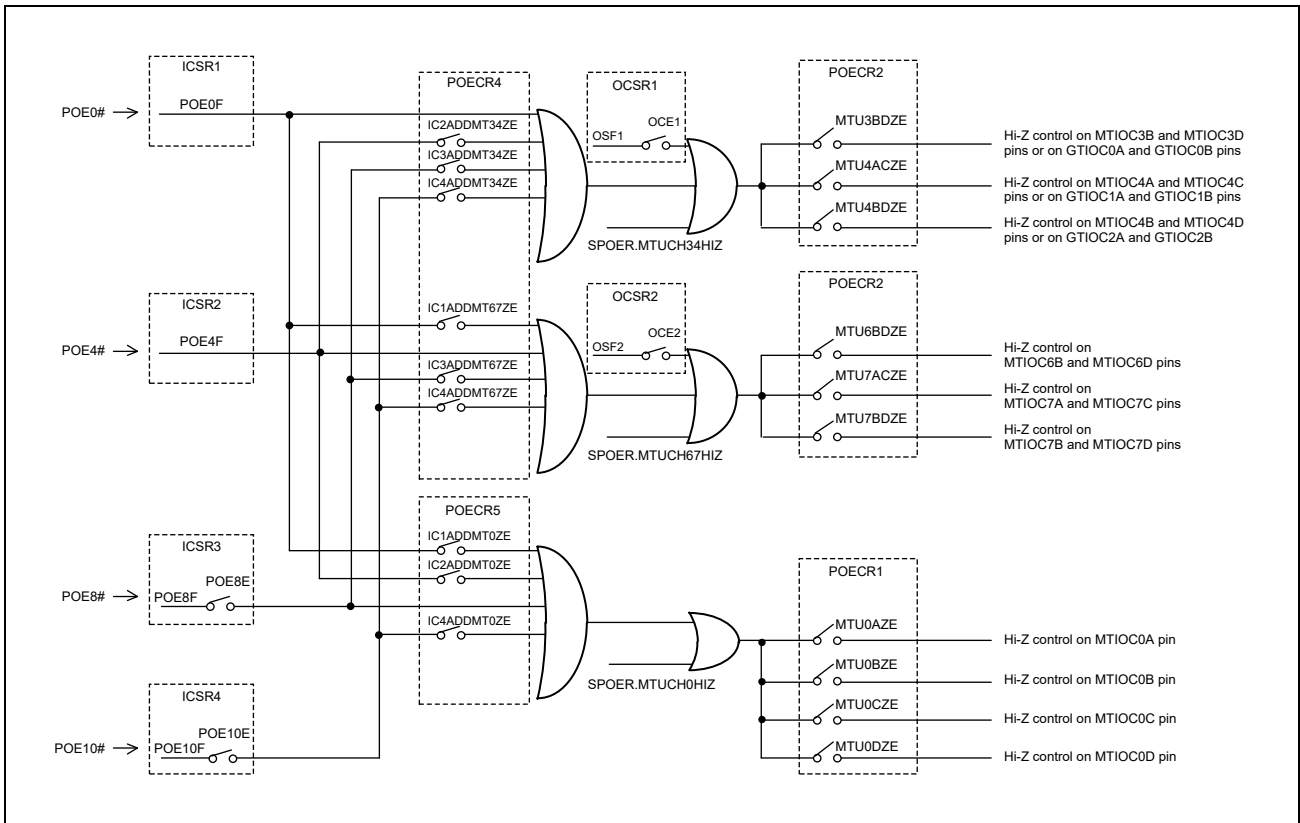

Figure 17.2 Target Pins and Conditions for High-Impedance Control

High-impedance requests to individual pins can be controlled by the settings in the POECR1 to POECR2 registers.

The following input pins can be added to high-impedance control conditions by the settings in the POECR4 to POECR5 registers: input pins other than the POE0# pin for the MTU3 and MTU4 pins; input pins other than the POE4# pin for the MTU6 and MTU7 pins; input pins other than the POE8# pin for the MTU0 pins.

For example, setting the IC2ADDMT34ZE bit in POECR4 to 1 outputs high-impedance requests to the MTU3 and MTU4 pins even when the POE4# input is detected.

High-impedance requests due to the detection of POE8# input or POE10# input can be controlled by the settings in the ICSR3 to ICSR4 registers. (The ICSR1 and ICSR2 registers do not control enabling or disabling of output of high-impedance requests.)

High-impedance requests to the MTU3, MTU4, MTU6, and MTU7 pins as the results of output level comparison can be controlled by the settings in the OCSR1 and OCSR2 registers.

17.3.1 MTU Pin Selection

In this LSI, each terminal function for MTU is assigned to multiple ports. **Table 17.6** shows the correspondence table of MTU terminal functions and compatible ports. The pin used as the MTU must be set separately in the general-purpose I / O port register. (Set by PMCN and PFCm registers of IO_TOP)

Table 17.6 Correspondence between MTU Pins (1/3)

MTU Pin Functions	Corresponding Ports
MTCLKA	P2_0
MTCLKB	P2_1
MTCLKC	P2_2
MTCLKD	P2_3
MTIOC0A	P3_0
	P7_0
	P12_0
	P23_1
MTIOC0B	P3_1
	P7_1
	P12_1
	P23_2
MTIOC0C	P3_2
	P7_2
MTIOC0D	P3_3
	P7_3
MTIOC1A	P0_2
	P1_0
MTIOC1B	P0_3
	P1_1
MTIOC2A	P0_0
	P4_0
MTIOC2B	P0_1
	P4_1
MTIOC3A	P4_2
	P17_0
	P20_3
MTIOC3B	P4_3
	P17_1
	P20_4
MTIOC3C	P4_4
	P17_2
	P20_5
MTIOC3D	P4_5
	P17_3
	P20_6

Table 17.6 Correspondence between MTU Pins (2/3)

MTU Pin Functions	Corresponding Ports
MTIOC4A	P9_0
	P13_0
	P19_1
	P23_3
MTIOC4B	P9_1
	P13_1
	P20_0
	P23_4
MTIOC4C	P9_2
	P13_2
	P20_1
	P23_5
MTIOC4D	P9_3
	P13_3
	P20_2
	P24_0
MTIC5U	P1_2
	P14_0
	P24_2
MTIC5V	P1_3
	P14_1
	P24_3
MTIC5W	P1_4
	P14_2
	P24_4
MTIOC6A	P10_0
	P20_3
MTIOC6B	P10_1
	P20_4
MTIOC6C	P10_2
	P20_5
MTIOC6D	P10_3
	P20_6
MTIOC7A	P5_0
	P6_0
	P8_0
MTIOC7B	P5_1
	P6_1
	P8_1
MTIOC7C	P5_2
	P6_2
	P8_2
MTIOC7D	P5_3
	P6_3
	P8_3

Table 17.6 Correspondence between MTU Pins (3/3)

MTU Pin Functions	Corresponding Ports
MTIOC8A	P4_0
	P15_0
	P19_0
MTIOC8B	P4_1
	P15_1
	P20_0
MTIOC8C	P4_2
	P15_2
	P20_1
MTIOC8D	P4_3
	P15_3
	P20_2

17.3.2 Input Level Detection Operation

If the input conditions set by ICSR1 to ICSR4 occur on the POE0#, POE4#, POE8#, and POE10# pins, the MTU3 and MTU4 or MTU6 and MTU7 pins for the MTU complementary PWM output, and MTU0 pin are placed in high-impedance state. Note however, that these pins are still placed in the high-impedance state even when the MTU functions are not selected for the pins.

(1) Falling Edge Detection

When a change from a high to low level is input to the POE0#, POE4#, POE8#, and POE10# pins, the pins for the MTU complementary PWM output, and pin functions multiplexed with the MTU0 pins are placed in high-impedance state.

Figure 17.3 shows a sample timing after the level changes in input to the POE0#, POE4#, POE8#, and POE10# pins until the respective pins enter high-impedance state.

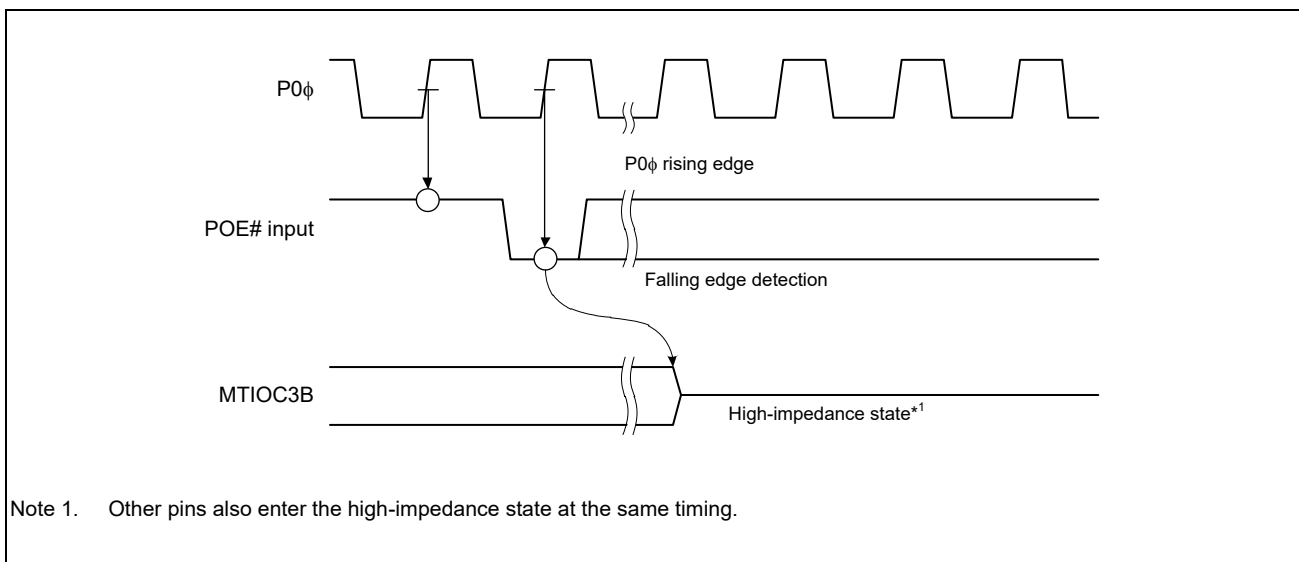

Figure 17.3 Falling Edge Detection

(2) Low-Level Detection

Figure 17.4 shows the low-level detection operation. Sixteen continuous low levels are sampled with the sampling clock selected by ICSR1 to ICSR4. If even one high level is detected during this interval, the low level is not accepted. The timing when pins for the MTU complementary PWM output, and MTU0 pins enter the high-impedance state after the sampling clock is input is the same in both falling-edge detection and in low-level detection.

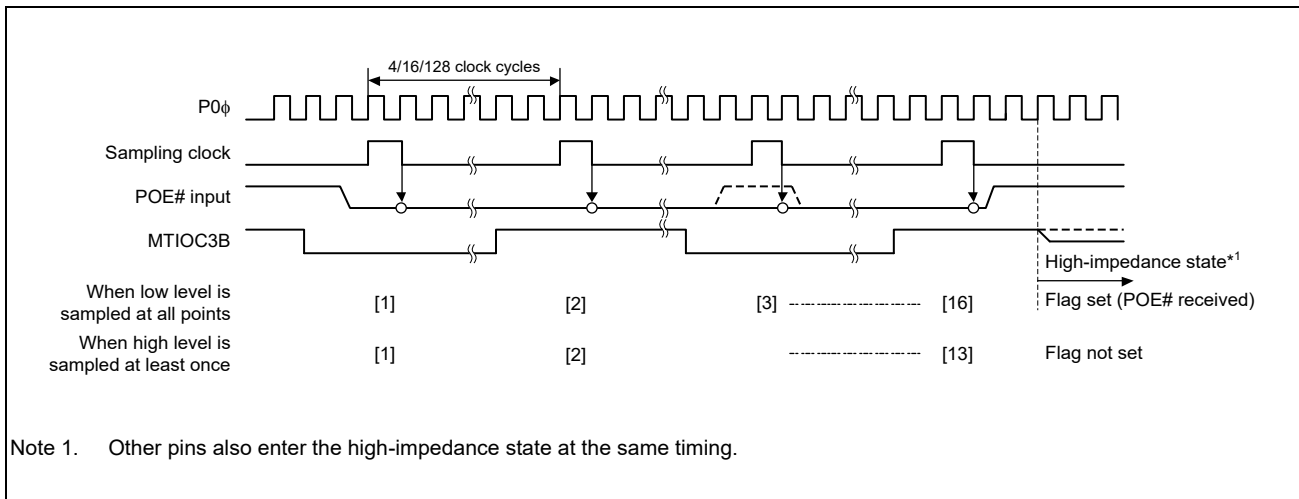

Figure 17.4 Low-Level Detection Operation

17.3.3 Output Level Compare Operation

Figure 17.5 shows an example of the output level compare operation for the combination of MTIOC3B and MTIOC3D. The operation is the same for the other pin combinations.

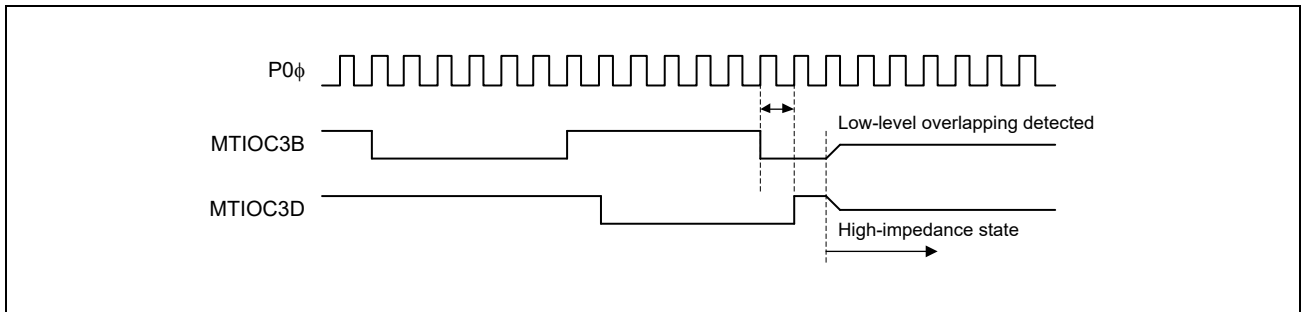

Figure 17.5 Output Level Compare Operation

17.3.4 High-Impedance Control Using Registers

The high-impedance state of the MTU pins (MTU0, MTU3, MTU4, MTU6, and MTU7) can be directly controlled by using the software port output enable register (SPOER).

For instance, setting the MTUCH34HIZ bit in SPOER to 1 places the MTU3 and MTU4 pins specified by the port output enable control register 2 (POECR2) in the high-impedance state.

The high-impedance state of other pins can also be controlled by setting the appropriate bits in SPOER.

17.3.5 Additional Functions for Controlling High-Impedance States

Settings in port enable registers 4 to 5 (POECR4 and POECR5) can add further high-impedance control conditions for the MTU complementary PWM output and MTU0 pins.

For instance, the settings listed below can be added as high-impedance control conditions for the MTU3 and MTU4 pins.

- Setting the IC2ADDMT34ZE bit in POECR4 to 1 adds the input level detection by the POE4#
- Setting the IC3ADDMT34ZE bit in POECR4 to 1 and adds the input level detection by the POE8#
- Setting the IC4ADDMT34ZE bit in POECR4 to 1 and adds the input level detection by the POE10# (ICSR4.POE10F)

The high-impedance state of other pins can also be controlled by setting the appropriate bits in the POECR4 and POECR5.

17.3.6 Release from High-Impedance State

MTU pins which have entered high-impedance state due to input-level detection can be released from the state either by returning them to their initial state with a reset, or by clearing all of the ICSR1.POE0F, ICSR2.POE4F, ICSR3.POE8F, and ICSR4.POE10F flags. However, note that when low-level sampling is selected with the ICSR1.POE0M[1:0], ICSR2.POE4M[1:0], ICSR3.POE8M[1:0], ICSR4.POE10M[1:0], and ICSR5.POE10M[1:0] bits, just writing 0 to a flag is ignored (the flag is not cleared); flags can be cleared by writing 0 to it only after a high level is input to the POE0#, POE4#, POE8#, and POE10# pins and is sampled.

MTU pins which have entered high-impedance state due to output level detection can be released from the state either by returning them to their initial state with a reset, or by clearing the OCSR1.OSF1 flag or the OCSR2.OSF2 flag.

17.4 POE3 Setting Procedure

Figure 17.6 shows the POE3 configuration procedure. As an example, high impedance control by comparing the output levels of the MTU 3 terminals (MTIOC3B / MTIOC3D) is shown. In **Figure 17.6**, select P32_1 for the MTIOC3B terminal and P36_1 for the MTIOC3D terminal.

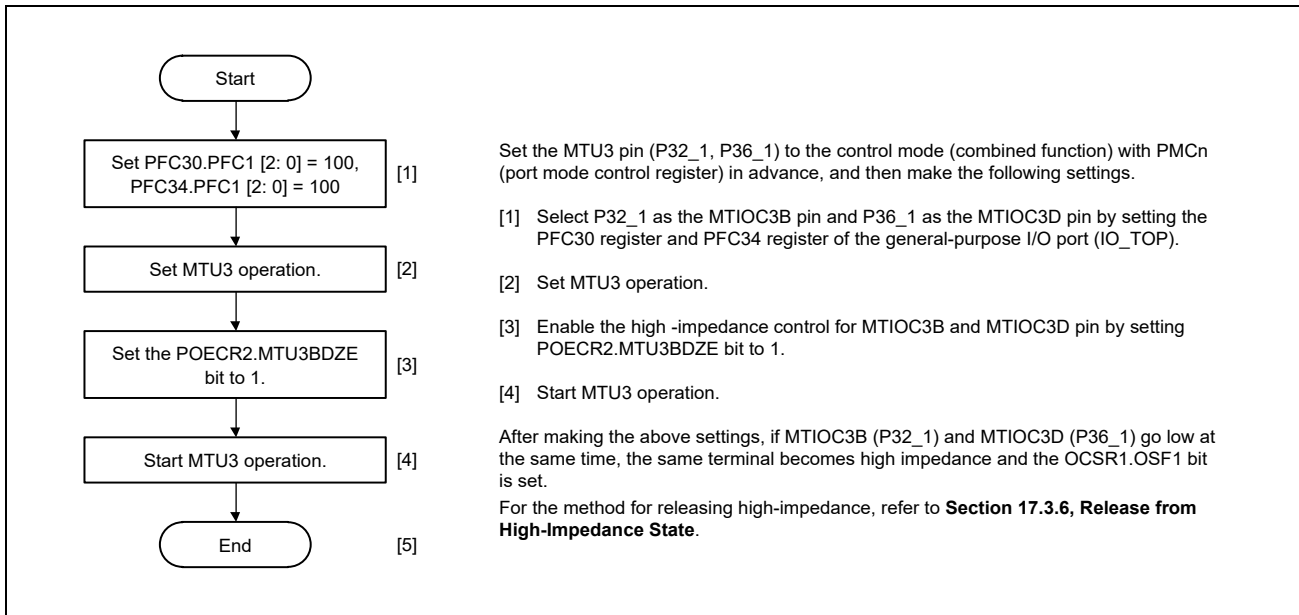

Figure 17.6 Procedure for Setting POE3

17.5 Interrupts

The POE3 issues a request to generate an interrupt when the specified condition is satisfied during input level detection or output level comparison. **Table 17.7** shows the interrupt sources and their conditions.

Table 17.7 Interrupt Sources and Conditions

Name	Interrupt Source	Interrupt Flag	Condition
OEI1	Output enable interrupt 1	POE0F and OSF1	PIE1•POE0F+OIE1•OSF1
OEI2	Output enable interrupt 2	POE4F and OSF2	PIE2•POE4F+OIE2•OSF2
OEI3	Output enable interrupt 3	POE8F	PIE3•POE8F
OEI4	Output enable interrupt 4	ICSR4.POE10F	PIE4•ICSR4.POE10F

17.6 Usage Notes

17.6.1 High-Impedance Control when MTU6 and MTU7 are not Used

When MTU6 and MTU7 are not to be used, set the POECR2.MTU6BDZE, MTU7ACZE, and MTU7BDZE bits to 0 to disable high-impedance control.

20. General Timer (GTM)

20.1 Functional Overview

The General timer has the following features.

- Two operating modes
 - Interval timer mode
 - Free-running comparison mode
- Choice between startup of DMA by compare match and generation of interrupt

20.1.1 Features of GTM

Channels

This product has the following number of channels of the General timer.

Table 20.1 Channels of General Timer

General Timer	
Number of Channels	3
Name	OSTMn

Note: n = 0, 1, 2

Meaning of n

Throughout this section, the individual channels of the General timer are identified by the index “n” (n = 0, 1, 2), for example OSTMnTO for the General timer n output register.

Register address

The register addresses of the General timer are given as offsets from the individual base addresses <OSTMn_base>. The register base addresses of each OSTMn are listed in the following table.

Table 20.2 Register Base Addresses

Base Address Name	Base Address
<OSTM0_base>	H'0_1280_1000
<OSTM1_base>	H'0_1280_1400
<OSTM2_base>	H'0_1280_1800

Interrupts

The General timers can generate the following interrupt requests.

Table 20.3 OSTMn Interrupt Requests

OSTMn Signal	Function	Startup of Direct Memory Access Controller
OSTM0TINT	OSTM0 interrupt	✓
OSTM1TINT	OSTM1 interrupt	✓
OSTM2TINT	OSTM2 interrupt	✓

20.2 Registers

The General timer is controlled by the following registers.

20.2.1 Registers Overview

The list of OSTMn (n = 0, 1, 2) registers and the memory addresses are as follows.

For the base addresses, see **Table 20.2**.

For the actual addresses, the offset values indicated in the following table are added to the base addresses.

Register Name	Function	R/W	Reset Value	Access Unit (bit)			Address
				8	16	32	
OSTMnCMP	OSTM compare register	R/W	H'0000 0000	—	—	✓	<OSTMn_base> + H'00
OSTMnCNT	OSTM counter register	R	H'FFFF FFFF	—	—	✓	<OSTMn_base> + H'04
OSTMnTE	OSTM count enable status register	R	H'00	✓	—	—	<OSTMn_base> + H'10
OSTMnTS	OSTM count start trigger register	W	H'00	✓	—	—	<OSTMn_base> + H'14
OSTMnTT	OSTM count stop trigger register	W	H'00	✓	—	—	<OSTMn_base> + H'18
OSTMnCTL	OSTM control register	R/W	H'00	✓	—	—	<OSTMn_base> + H'20

20.2.2 Details of OSTM Registers

20.2.2.1 OSTMnCMP — OSTM Compare Register

Depending on the mode of operation, this register holds the start value for the down-counter or the value for comparison with that of the counter.

Access Size: This register is readable/writable in 32-bit units.

Address(es): <OSTMn_base>

Initial Value: H'0000 0000

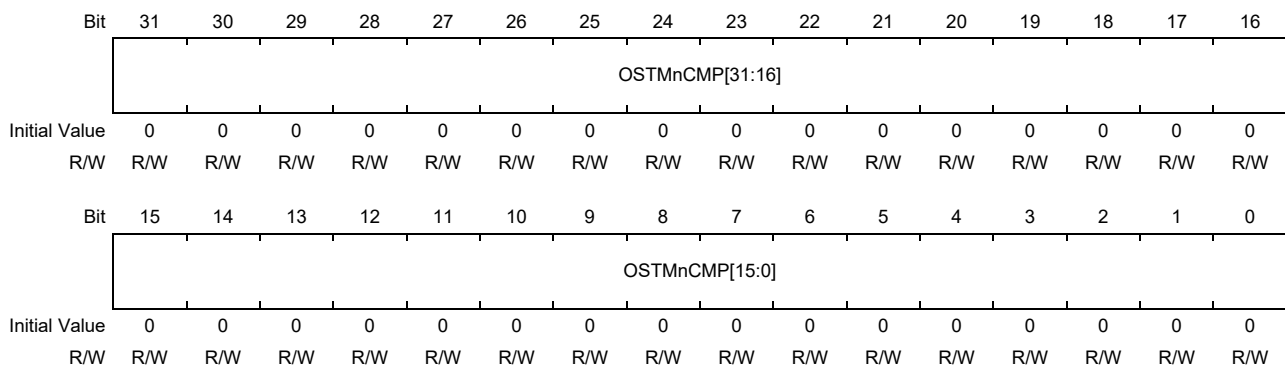

Bit	Bit Name	Initial Value	R/W	Description
31 to 0	OSTMnCMP[31:0]	All 0	R/W	<ul style="list-style-type: none"> In interval timer mode: start value of the down-counter In free-running comparison mode: value for comparison

20.2.2.2 OSTMnCNT — OSTM Counter Register

This register indicates the counter value of the timer.

Access Size: This register is readable in 32-bit units.

Address(es): <OSTMn_base> + H'4

Initial Value: The initial value depends on the operating mode of the General timer. Refer to **Table 20.4**

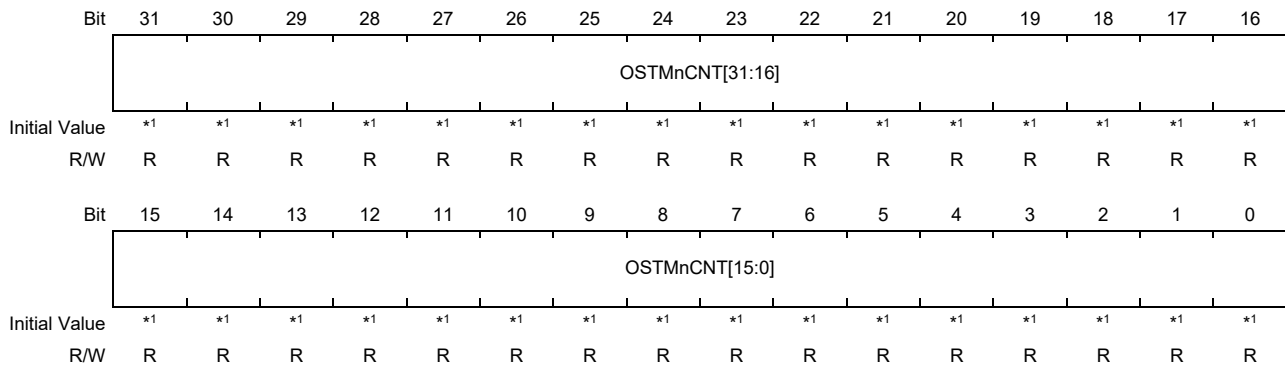

Bit	Bit Name	Initial Value	R/W	Description
31 to 0	OSTMnCNT [31:0]	*1	R	32-bit counter value

Note 1. The initial value depends on the operating mode of the General timer. Refer to **Table 20.4**

The following table shows the correspondence between operating mode, counting direction and initial value. The initial value is the value read from the counter after a change to the operating mode.

Table 20.4 Correspondence between Operating Mode, Counting Direction and Initial Value

Timer Operating Mode	OSTMnCTL.OSTMnMD1	Counting Direction	Initial value
Interval timer mode	0*1	Down	H'FFFF FFFF
Free-running comparison mode	1	Up	H'0000 0000

Note 1. Value after reset

20.2.2.3 OSTMnTE — OSTM Count Enable Status Register

This register indicates whether the counter is enabled or disabled.

Access Size: This register is readable in 8-bit units.

Address(es): <OSTMn_base>+ H'10

Initial Value: H'00

Bit	7	6	5	4	3	2	1	0
	—	—	—	—	—	—	—	OSTMn TE
Initial Value	0	0	0	0	0	0	0	0
R/W	R	R	R	R	R	R	R	R

Bit	Bit Name	Initial Value	R/W	Description
7 to 1	—	All 0	R	Reserved These bits are always read as 0. The write value should always be 0.
0	OSTMnTE	0	R	This bit indicates whether the counter is enabled or disabled. 0: Counter disabled 1: Counter enabled This bit is set to 1 in response to OSTMnTS.OSTMnTS being set to 1. This bit is reset to 0 in response to OSTMnTT.OSTMnTT being set to 1.

Note 1. When OSTMnTE = 0, the counter retains its value.
If the counter is restarted, it

- restarts counting down from the value in the OSTMnCMP register if it is in interval timer mode or
- restarts counting up from the counter value H'0000 0000 if it is in free running comparison mode.

Note 1. For debugging, the GTM counter can be paused by the counter stop request.

20.2.2.4 OSTMnTS — OSTM Count Start Trigger Register

This register starts the counter.

Access Size: This register is writable in 8-bit units. It is always read as H'00.

Address(es): <OSTMn_base>+ H'14

Initial Value: H'00

Bit	7	6	5	4	3	2	1	0
	—	—	—	—	—	—	—	OSTMnTS
Initial Value	0	0	0	0	0	0	0	0
R/W	R	R	R	R	R	R	R	W

Bit	Bit Name	Initial Value	R/W	Description
7 to 1	—	All 0	R	Reserved These bits are always read as 0. The write value should always be 0.
0	OSTMnTS	0	W	This bit starts the counter. 0: This setting has no effect. 1: Starts the counter and sets OSTMnTE.OSTMnTE = 1. <ul style="list-style-type: none"> In interval timer mode, a forced restart is executed if this bit is set while OSTMnTE.OSTMnTE = 1. In free-running comparison mode, setting this bit is ignored as long as OSTMnTE.OSTMnTE = 1.

20.2.2.5 OSTMnTT — OSTM Count Stop Trigger Register

This register stops the counter.

Access Size: This register is writable in 8-bit units. It is always read as H'00.

Address(es): <OSTMn_base>+ H'18

Initial Value: H'00

Bit	7	6	5	4	3	2	1	0
	—	—	—	—	—	—	—	OSTMnTT
Initial Value	0	0	0	0	0	0	0	0
R/W	R	R	R	R	R	R	R	W

Bit	Bit Name	Initial Value	R/W	Description
7 to 1	—	All 0	R	Reserved These bits are always read as 0. The write value should always be 0.
0	OSTMnTT	0	W	Stops the counter. 0: This setting has no effect. 1: Stops the counter and clears the OSTMnTE.OSTMnTE bit.

20.2.2.6 OSTMnCTL — OSTM Control Register

This register specifies the operating mode for the counter and controls enabling/disabling of OSTMnTINT interrupt requests when counting starts.

Access Size: This register is readable/writable in 8-bit units. Writing to this register is only possible if the counter is disabled (OSTMnTOE.OSTMnTOE = 0).

Address(es): <OSTMn_base>+ H'20

Initial Value: H'00

Bit	7	6	5	4	3	2	1	0
	—	—	—	—	—	—	OSTMnMD1	OSTMnMD0
Initial Value	0	0	0	0	0	0	0	0
R/W	R	R	R	R	R	R	R/W	R/W

Bit	Bit Name	Initial Value	R/W	Description
7 to 2	—	All 0	R	Reserved These bits are always read as 0. The write value should always be 0.
1	OSTMnMD1	0	R/W	Specifies the operating mode for the counter. 0: Interval timer mode 1: Free-running comparison mode
0	OSTMnMD0	0	R/W	Controls enabling/disabling of OSTMnTINT interrupt requests when counting starts. 0: Disables the interrupts when counting starts. 1: Enables the interrupts when counting starts.

20.3 Functional Description

Each General timer is a 32-bit timer/counter.

The settings for operating mode specify the direction of counting (up or down) and the generation of interrupt requests.

20.3.1 Block Diagram

The following block diagram shows the main components of GTM.

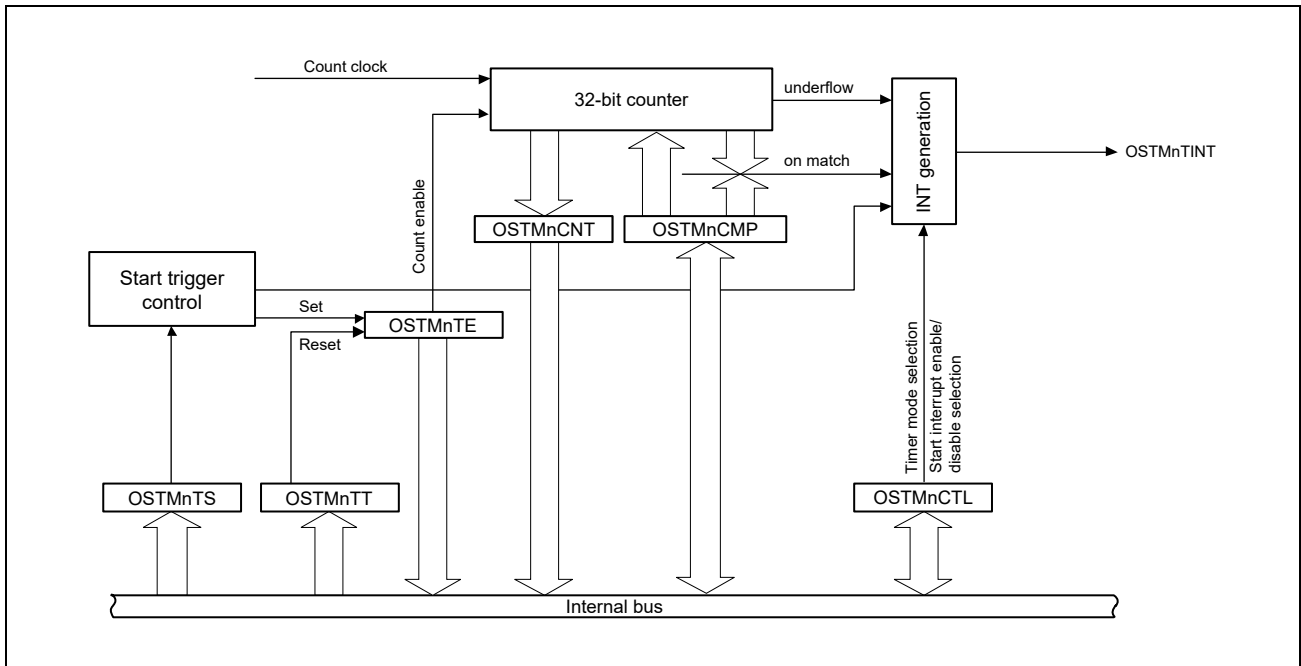

Figure 20.1 Block Diagram of GTM

20.3.2 Count Clock

The count clock of OSTMn is P0φ (OSTMn_PCLK).

20.3.3 Generation of Interrupt Request

An OSTMnTINT interrupt request is generated whenever the counter reaches H'0000 0000 (in interval timer mode) or matches the comparison value (in free-running comparison mode).

An interrupt request can also be generated on starting and restarting of the counter. This is controlled by the OSTMnCTL.OSTMnMD0 bit.

This operation is shown in the following figure.

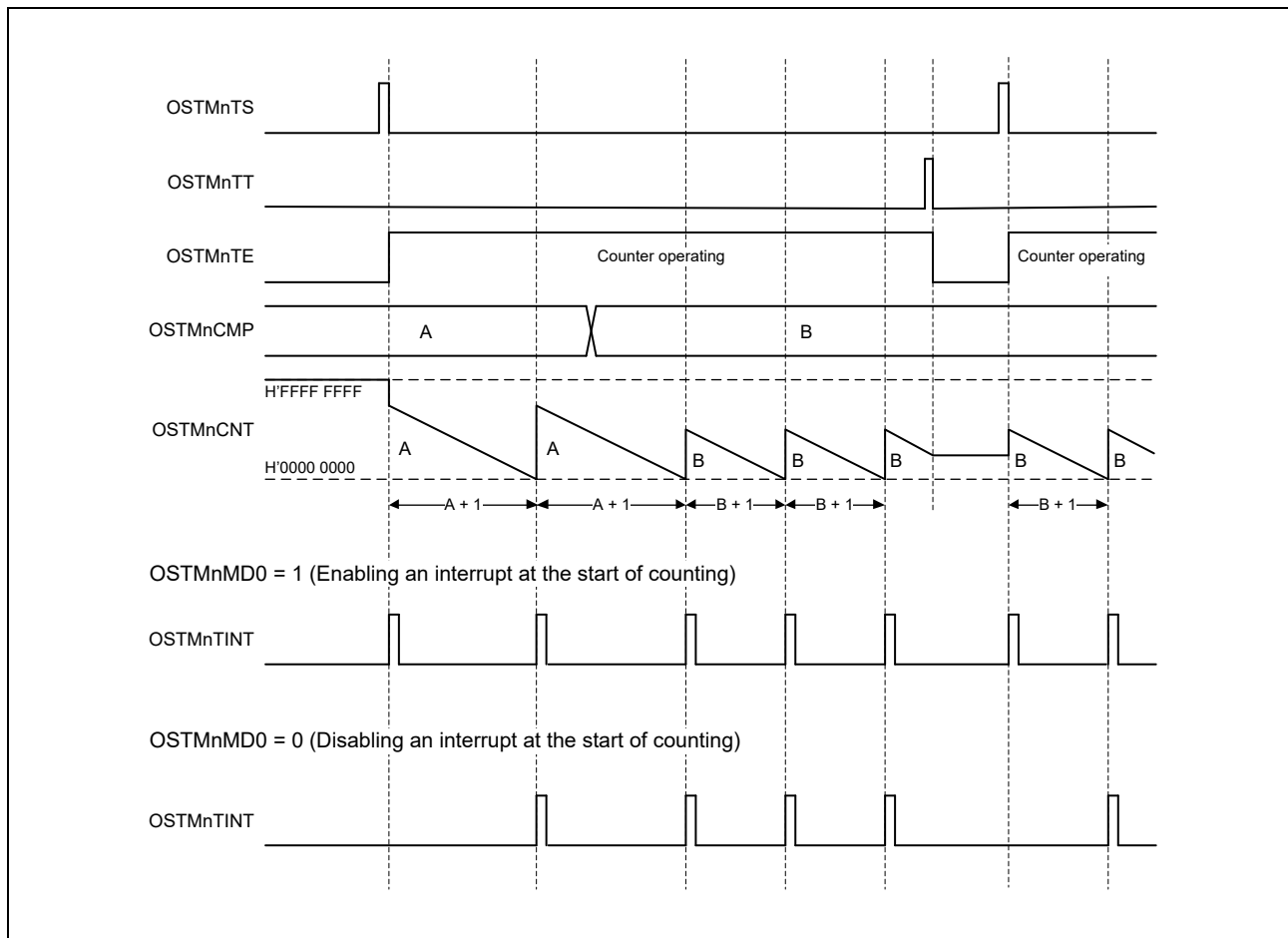

Figure 20.2 Generating an Interrupt when Counting Starts (in Interval Timer Mode)

20.3.4 Starting and Stopping the Timer

The General timer is started and stopped as follows.

Starting the timer

The timer is started in either of the following way:

- setting the OSTMnTS.OSTMnTSF bit to 1

Status bit OSTMnTE.OSTMnTE is set to 1.

The counter starts to count up or down in accord with the settings for operating mode.

Stopping the timer

Setting the OSTMnTT.OSTMnTT bit to 1 stops the timer.

This also clears the OSTMnTE.OSTMnTE status flag.

20.3.5 Interval Timer Mode

Select the interval timer mode when the General timer is to be used as a reference timer for generating interrupt requests at a fixed interval.

20.3.5.1 Basic Operation in Interval Timer Mode

In interval timer mode, the timer counts down from the value specified in the OSTMnCMP register. An OSTMnTINT interrupt request is generated when the counter reaches H'0000 0000.

Select interval timer mode by setting OSTMnCTL.OSTMnMD1 = 0.

New values can be written to the OSTMnCMP register at any time. If it is rewritten during count operation, the counter loads the new OSTMnCMP value when the next H'0000 0000 is reached.

Cycles of OSTMnTINT output

The cycle of OSTMnTINT output is as follows.

- OSTMnTINT generation cycle = counter-clock cycle × (OSTMnCMP + 1)

The following figure shows the basic operation of OSTM when counter-start interrupts is enabled in interval timer mode.

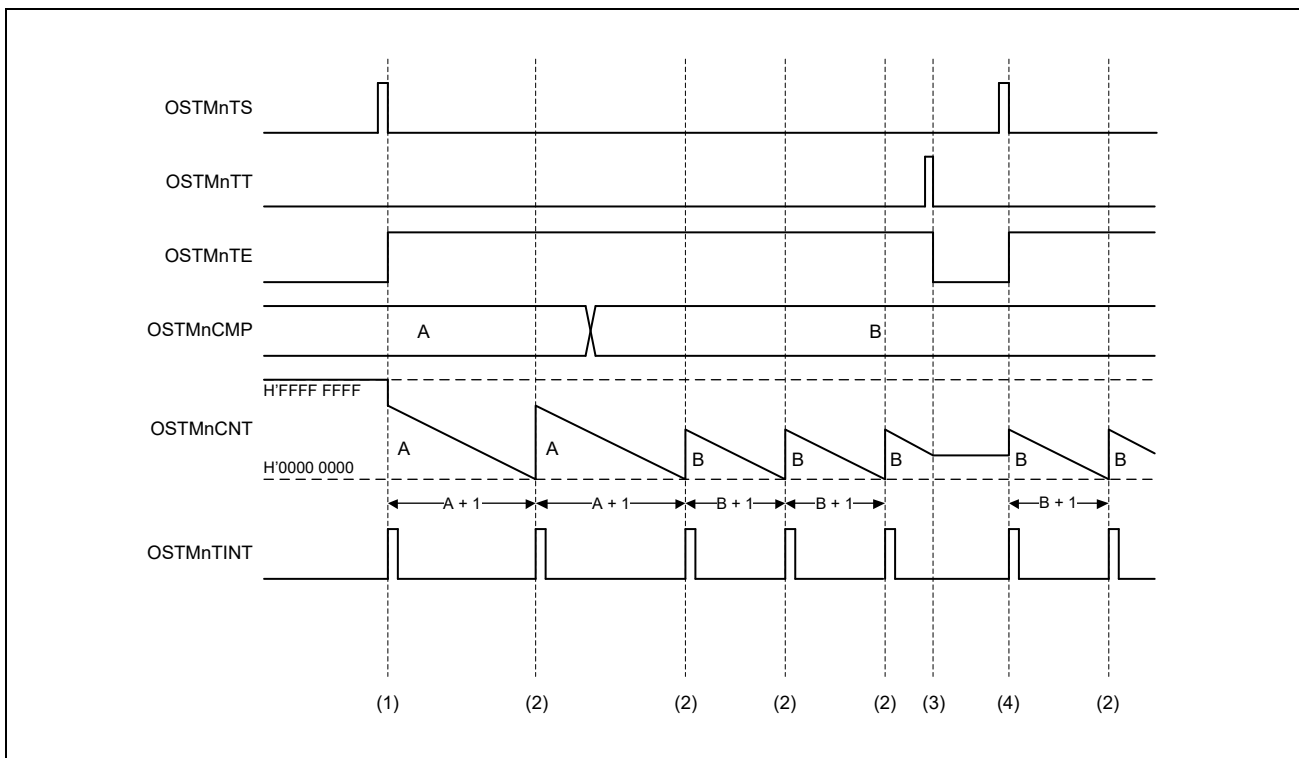

Figure 20.3 Timing Diagram of OSTM in Interval Timer Mode

The timing diagram above shows the following:

- (1) The counter starts counting when OSTMnTS.OSTMnTS = 1. The OSTMnTE.OSTMnTE bit is set to indicate enabling of the counter.
The counter starts counting down from the value of OSTMnCMP.
If OSTMnCTL.OSTMnMD0 is 1, OSTMnTINT interrupt requests are generated at the start of counting. The OSTMnCNT register contains the current value as the counter.

- (2) When the counter reaches H'0000 0000, an OSTMTINT interrupt request is generated. The counter loads the new start value from OSTMnCMP and continues counting down.
- (3) When the counter is stopped (OSTMnTT.OSTMnTT = 1), the OSTMnTE.OSTMnTE bit is cleared to indicate disabling of the counter. The counter retains its current value until it is restarted.
- (4) When counting is restarted (OSTMnTS.OSTMnTS = 1), the counter loads the new start value from OSTMnCMP and starts counting down.

Forced restart

The counter is forcibly restarted by setting OSTMnTS.OSTMnTS = 1 during counting.

The counter loads the start value from the OSTMnCMP register and continues to count down.

The following figure shows the forced restart of the General Timer in interval timer mode, with counter-start interrupts enabled (OSTMnCTL.OSTMnMD0 = 1).

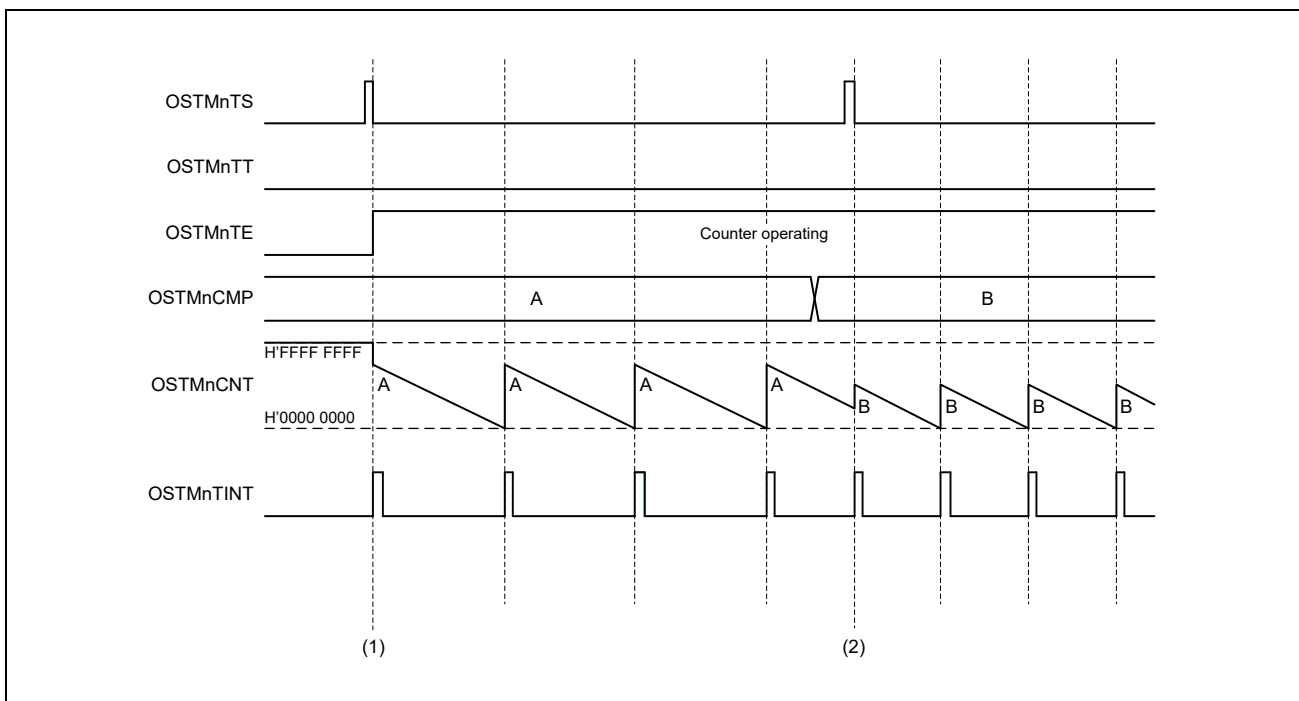

Figure 20.4 Timing Diagram of Forced Restart in Interval Timer Mode

Operations shown in the above timing diagram are as follows.

- (1) The counter is started and stopped as described under **Figure 20.3, Timing Diagram of OSTM in Interval Timer Mode**.
- (2) Setting OSTMnTS.OSTMnTS = 1 restarts the counter while counting is in progress (i.e. while OSTMnTE.OSTMnTE = 1).
The counter immediately restarts counting down, starting with the current value of OSTMnCMP.
When OSTMnCTL.OSTMnMD0 = 1, an OSTMTINT interrupt request is generated when counting starts.

20.3.5.2 Operation when OSTMnCMP = H'0000 0000

When OSTMnCMP = H'0000 0000, OSTM behaves as follows.

- When the counter is enabled, the OSTMTINT interrupt request is always set to 1.

The following figure shows operations of OSTM when OSTMnCMP = H'0000 0000, and counter-start interrupts are enabled.

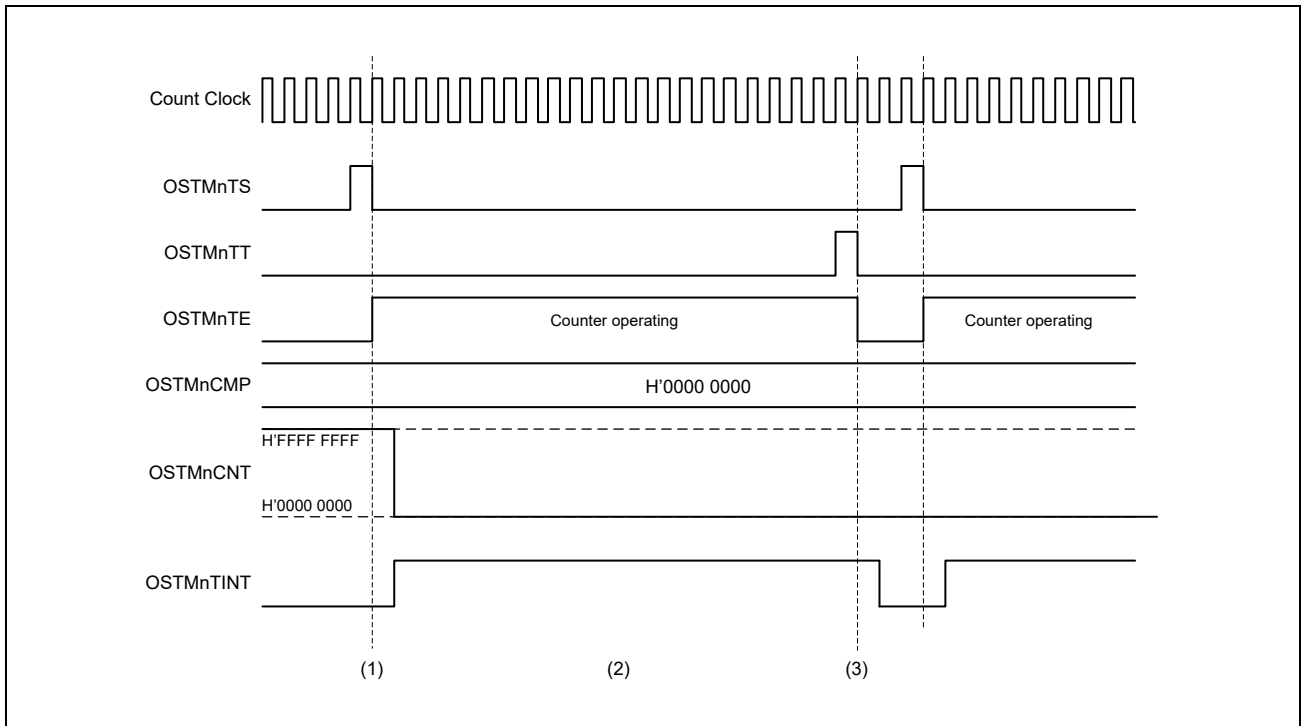

Figure 20.5 Timing Diagram when OSTMnCMP = H'0000 0000 in Interval Timer Mode

The timing diagram above shows the following operations:

- (1) The counter is reloaded with the value in OSTMnCMP as soon as it starts counting, so the value H'0000 0000 is retained in OSTMnCMP.
- (2) The OSTMTINT interrupt request is continuously asserted.
- (3) After the counter stops, the OSTMTINT interrupt request signal is deasserted.
- (4) When interrupts on starting of the counter are disabled, no interrupt is generated when counting starts.

20.3.6 Free-Running Comparison Mode

20.3.6.1 Basic Operation in Free-Running Comparison Mode

In free-running comparison mode, the counter counts up from H'0000 0000 to H'FFFF FFFF. An OSTMnTINT interrupt request is output when the current value of the counter matches the value of the OSTMnCMP register. The free-running comparison mode is selected by setting the OSTMnCTL.OSTMnMD1 bit to 1.

New values can be written to the OSTMnCMP register at any time.

The following figure shows the basic operation of OSTM in free-run compare mode with the start of counting enabled (OSTMnCTL.OSTMnMD0 = 1).

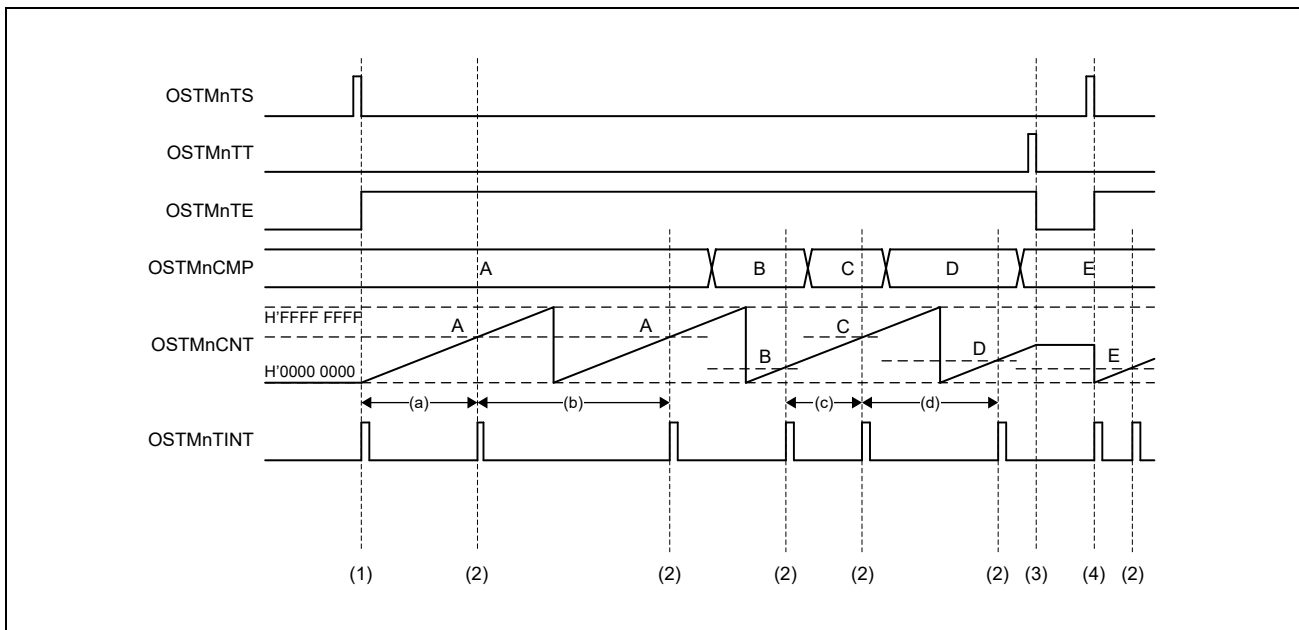

Figure 20.6 Timing Diagram of OSTM in Free-Run Compare Mode

The timing diagram above shows the following:

- (1) The counter starts counting when OSTMnTS.OSTMnTS = 1.
The OSTMnTE.OSTMnTE bit is set to indicate enabling of the counter. The counter counts up from H'0000 0000 to H'FFFF FFFF. The OSTMnCNT register is the counter, so it contains the current value.
When OSTMnCTL.OSTMnMD0 = 1, an OSTMTINT interrupt request is generated at the start of counting.
- (2) When the current counter value matches the value in the OSTMnCMP register, an OSTMTINT interrupt request is generated.
- (3) When the counter is stopped (OSTMnTT.OSTMnTT = 1), the OSTMnTE.OSTMnTE bit is cleared to indicate disabling of the counter.
The counter retains its current value until it is restarted.
- (4) Counting by the counter restarts from H'0000 0000 when OSTMnTS.OSTMnTS = 1.

OSTMTINT period

The OSTMTINT generation period is different at the start of counting and depends on the old and new compare values if OSTMnCMP is rewritten during operation.

Table 20.5 OSTMTINT Generation Timing

Old Value for Comparison	New Value for Comparison	Counter Value at Time of Rewriting	Period of OSTMTINT Generation	Label in Timing Diagram
Counter starts			$(A + 1) \times \text{counter clock period}$	(a)
A	A	No rewriting	$(\text{H'FFFF FFFF} + 1) \times \text{counter clock period}$	(b)
B	$C > B$	$B < \text{counter value} < C$	$(C - B) \times \text{counter clock period}$	(c)
C	$D < C$	Counter value $> D, C$	$(\text{H'FFFF FFFF} - C + D + 1) \times \text{counter clock period}$	(d)

Forced restart

Forced restarting does not proceed during counting even if the OSTMnTS.OSTMnTS bit is set. The counter ignores the attempted setting and continues counting.

20.3.6.2 Operation when OSTMnCMP = H'0000 0000

The following figure shows the operation of OSTM when OSTMnCMP = H'0000 0000, and counter-start interrupts are enabled (OSTMnCTL.OSTMnMD0 = 1).

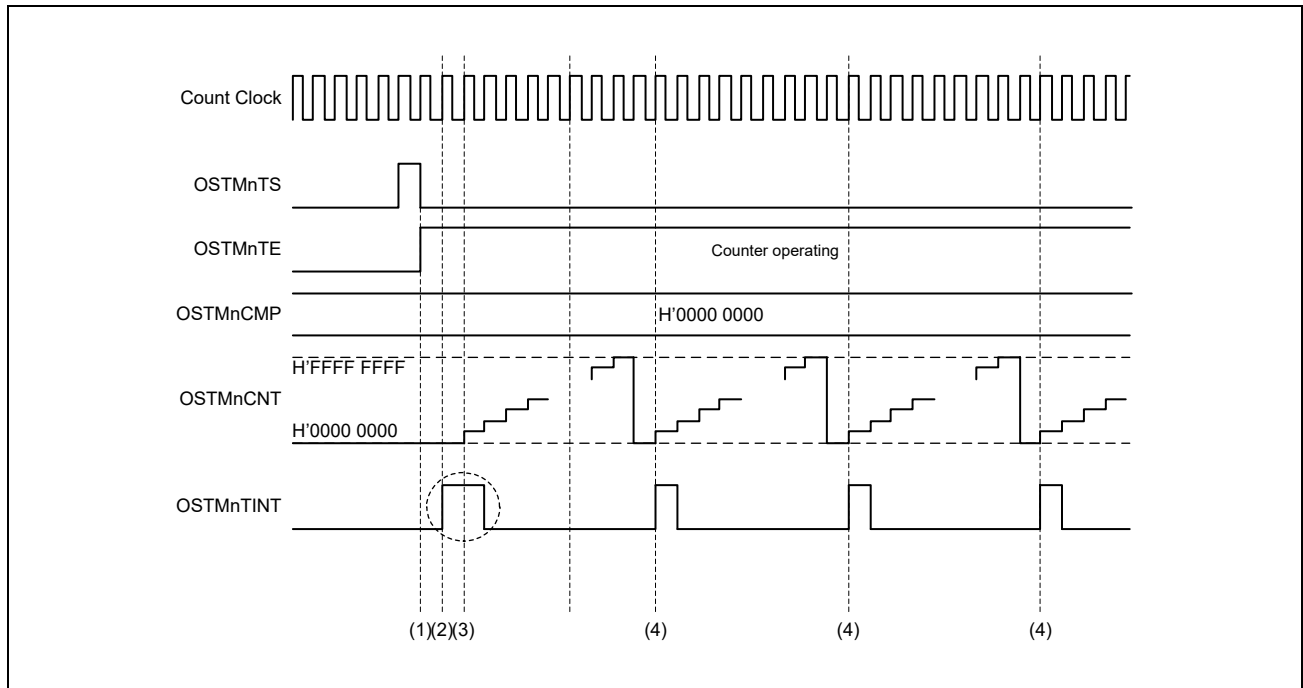

Figure 20.7 Timing Diagram when OSTMnCMP = H'0000 0000 in Free-Run Compare Mode

The timing diagram above shows the following operations.

- (1) Once the counter starts, it counts up from H'0000 0000 to H'FFFF FFFF.
- (2) An OSTMTINT interrupt request is generated when counting starts.
- (3) If the current counter value matches OSTMnCMP, an OSTMTINT interrupt request is generated. If OSTMnCMP = H'0000 0000 in the above case, OSTMTINT is generated over two clock cycles.
- (4) Every (H'FFFF FFFF + 1) clock cycles the OSTMTINT interrupt request is asserted.

When interrupts on starting of the counter are disabled, no interrupt is generated when counting starts.

21. Watchdog Timer (WDT)

This LSI has 1 channel of watchdog timer as **Table 21.1** and generates a reset request signal when the counter value is not rewritten and overflows due to system runaway.

Table 21.1 WDT Channels

Channel	Functions
WDT CH0	WDT to check the operation of AX45MP-CPU

Also, a reset request signal or interrupt signal can be generated by inputting a parity error signal due to a parity error in the CPU of this LSI.

21.1 Features

All WDT module has the following functions implemented in common as basic WDT functions.

21.1.1 Normal Watchdog Timer Function

- Bus interface: Compatible with AMBA[®] 2.0 APB.
- Operating frequency: Bus interface 100 [MHz], counter control 24 [MHz]
- The counter operation and the bus interface are asynchronous and can operate without depending on the size relationship of the clock cycles of each other.
- A 32-bit counter that operates with the clock (WDTn_CLK (n = 0)) input to this module.
- An interrupt request signal is generated every cycle set in the counter of this module.
- When WDTn_CLK (n = 0) = 24 MHz, the counter cycle can be set in 43.69 msec unit from 43.69 msec to 178956.97 msec.
- After the interrupt request signal is generated, if the software does not clear the watchdog timer until the next counter overflow, the reset request signal is generated.
- The set value of each register and the eElapsed time of the watchdog timer can be read.

21.1.2 Reset Request Function due to CPU Parity Error

- A reset request signal (WDTRSTB) or interrupt signal (PERROUT) is generated by inputting a parity error signal.
- The reset request signal is generated as the OR of the reset request of this module and the reset request of the parity error circuit.
- The polarity of the parity error signal can be set with this module.
- Function can be turned ON/OFF for each 32-bit parity error signal.
- The output of the reset request signal and the interrupt signal can be switched by inputting the parity error signal.
- It is possible to force a parity error to occur by register setting.

21.1.3 Internal Block Diagram

Figure 21.1 shows the internal block of WDT. WDT consists of a WDT-CORE part that implements the function of a normal watchdog timer and a part that detects a parity error.

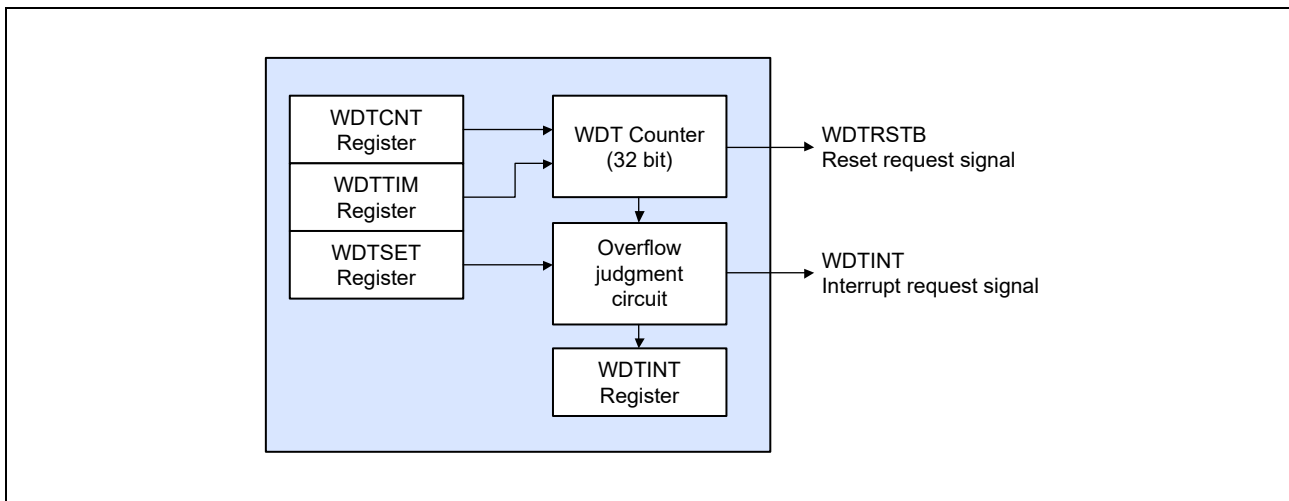

Figure 21.1 WDT_CORE Internal Block

In addition to the above WDT-Core function, WDT receives a parity error interrupt signal generated by the CPU when a Parity Error occurs in the CPU monitored by WDT and generates a reset request signal or interrupt request signal.

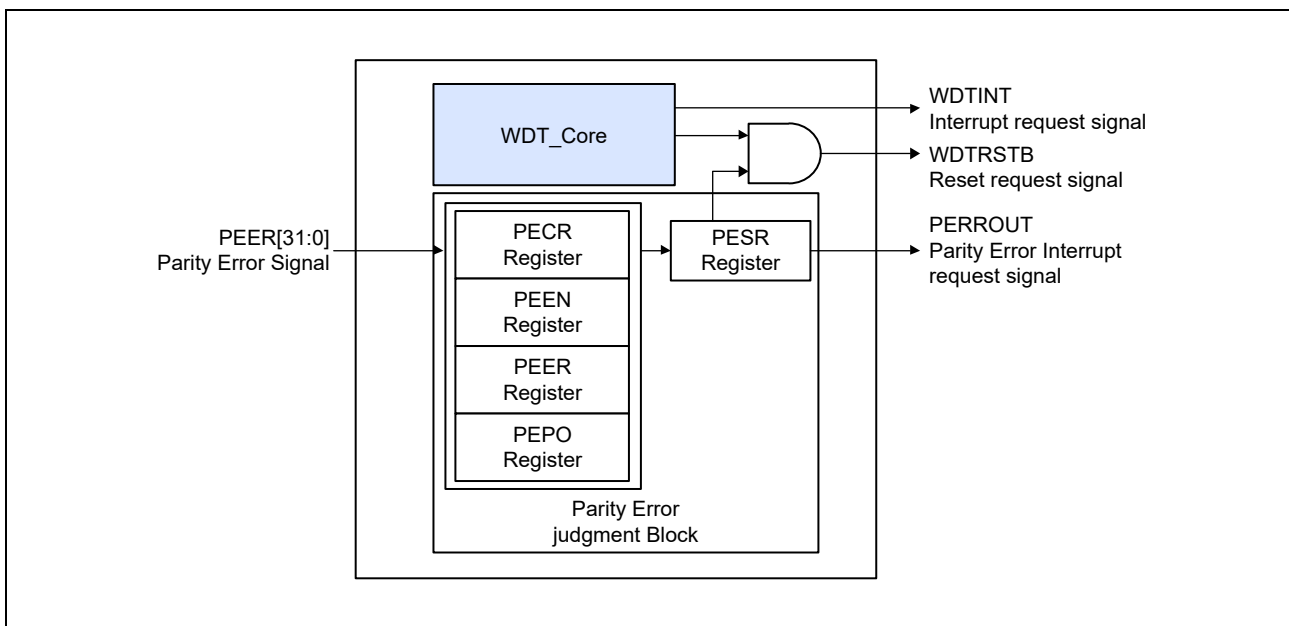

Figure 21.2 WDT_CORE and Parity Error handling block

21.1.4 Input/Output Pin

Table 21.2 shows the pin configuration.

Table 21.2 Pin Configuration

Watchdog timer overflow/ CPU parity error	WDTOVF_PERROUT#	Output	Watchdog timer counter overflow signal output/ Interrupt signal output when CPU parity error occurs

Note: When using with pin compatibility with RZ/G2UL or RZ/A3UL, please refer to the "RZ/G2UL Type-1, RZ/A3UL and RZ/Five Pin Compatibility Guide" (See Renesas web site).

21.2 Register Configuration

Table 21.3 shows the base address for WDT channel.

Table 21.3 Base Address for each WDT channel

	Channel	WDT	Base Address
AX45MP Address Space	WDT CH0	WDT to check the operation of AX45MP-CPU	H'0_1280_0800

Table 21.4 shows WDT Register Configuration on all WDT Channel.

Table 21.4 WDT Register Configuration

Channel	Register Name	Abbreviation	R/W	Initial Value	Address	Access Size
WDT CH0	WDT Control Register_0	WDTCNT_0	R/W	H'0000_0000	H'0000	32
	WDT Period Setting Register_0	WDTSET_0	R/W	H'FFF0_0000	H'0004	32
	WDT Elapsed Time Register_0	WDTTIM_0	R/W	H'0000_0000	H'0008	32
	WDT Interrupt control Register_0	WDTINT_0	R/W	H'0000_0000	H'000C	32
	Parity Error Control Register_0	PECR_0	R/W	H'0000_0000	H'0010	32
	Parity Error forced Enable Register_0	PEEN_0	R/W	H'0000_0000	H'0014	32
	Parity Status Register_0	PESR_0	R/W	H'0000_0000	H'0018	32
	Parity Error Enable Register_0	PEER_0	R/W	H'0000_0000	H'001C	32
	Parity Error Polarity setting Register_0	PEPO_0	R/W	H'0000_0000	H'0020	32

21.3 Register Descriptions

21.3.1 WDT Control Register_n (WDTCNT_n) (n = 0)

This register sets the operation enable of the watchdog timer function. Once the software activates the watchdog timer, the watchdog timer does not stop*¹ until it is reset. Also, the setting register*² of the watchdog timer cannot be changed. The setting register change must be completed*² before enabling the watchdog timer operation.

Note 1. For debugging, the internal counter can be paused with the CNTSTOP signal.

Note 2. WDT cycle setting register (WDTSET) and WDT eElapsed time register (WDTTIM)

Note 3. When changing the setting register, wait until the write data value of the setting register is reflected before enabling the watchdog timer operation. The reflection time of the setting register is $6 \times P0\phi + 9 \times OSCCLK$ or more. If this reflection time is not observed, the setting register value will not be reflected and will be ignored.

Bit	31	30	29	28	27	26	25	24	23	22	21	20	19	18	17	16
	—	—	—	—	—	—	—	—	—	—	—	—	—	—	—	—
Initial Value	0	0	0	0	0	0	0	0	0	0	0	0	0	0	0	0
R/W	R	R	R	R	R	R	R	R	R	R	R	R	R	R	R	R
Bit	15	14	13	12	11	10	9	8	7	6	5	4	3	2	1	0
	—	—	—	—	—	—	—	—	—	—	—	—	—	—	—	WDTEN
Initial Value	0	0	0	0	0	0	0	0	0	0	0	0	0	0	0	0
R/W	R	R	R	R	R	R	R	R	R	R	R	R	R	R	R	R/W

Bit	Bit Name	Initial Value	R/W	Description
31 to 1	—	All 0	R	Reserved When read, the initial value is read. The written value will be ignored.
0	WDTEN	0	R/W	Watchdog timer enable register 1: Watchdog timer operation enabled 0: Disabled

21.3.2 WDT Period Setting Register_n (WDTSET_n) (n = 0)

This register is used to set the cycle of the 32-bit counter that composes the watchdog timer. Writing is not possible while the watchdog timer is running. If you write continuously, the data written later will be valid. Calculate the watchdog timer cycle using the following formula.

$$\text{Watchdog timer cycle} = \text{WDTn_CLK (n = 0) cycle} \times 1024 \times 1024 \times (\text{WDTTIME setting value} + 1)$$

$$\text{WDTTIME setting value} = \frac{\text{WDT cycle}}{(\text{WDTn_CLK (n = 0) cycle} \times 1024 \times 1024) - 1}$$

For example, WDTn_CLK (n = 0) = 24 MHz, the counter cycle can be set in 43.69 msec unit from 43.69 msec to 178956.97 msec.

It can be set in units. The setting value of WDTTIME is the value set in WDTSET[31:20], and the value from H'000 to H'FFF can be set.

Bit	31	30	29	28	27	26	25	24	23	22	21	20	19	18	17	16
	WDTTI ME11	WDTTI ME10	WDTTI ME9	WDTTI ME8	WDTTI ME7	WDTTI ME6	WDTTI ME5	WDTTI ME4	WDTTI ME3	WDTTI ME2	WDTTI ME1	WDTTI ME0	—	—	—	—
Initial Value	1	1	1	1	1	1	1	1	1	1	1	1	0	0	0	0
R/W	R/W	R/W	R/W	R/W	R/W	R/W	R/W	R/W	R/W	R/W	R/W	R/W	R	R	R	R

Bit	15	14	13	12	11	10	9	8	7	6	5	4	3	2	1	0
	—	—	—	—	—	—	—	—	—	—	—	—	—	—	—	—
Initial Value	0	0	0	0	0	0	0	0	0	0	0	0	0	0	0	0
R/W	R	R	R	R	R	R	R	R	R	R	R	R	R	R	R	R

Bit	Bit Name	Initial Value	R/W	Description
31 to 20	WDTTIME [11:0]	All 1	R/W	Watchdog timer period cycle setting It cannot be written while the watchdog timer is running.
19 to 0	—	All 0	R	Reserved When read, the initial value is read. The written value will be ignored.

CAUTION

The value that the watchdog timer compares when an interrupt occurs is "WDTSET[31:0] + H'000F_FFFF". Therefore, when the setting value of this register is H'0010_0000, the interrupt occurrence count is "H'001F_FFFF" (not H'0010_0000).

21.3.3 WDT Elapsed Time Register_n (WDTTIM_n (n = 0))

This register indicates the 32-bit count value that composes the watchdog timer. If the watchdog timer is read during operation, the eElapsed time from the time it is cleared to the time of reading can be read.

By writing to this register when the watchdog timer is stopped, the value at the start of counting can be set in the 32-bit counter that configures the watchdog timer. When a value larger than the counter cycle (value when clearing) set in the WDT cycle setting register is written and the watchdog timer operation is started, the 32-bit counter once overflows and returns to 0. It operates at the set correct cycle.

You cannot write while the watchdog timer is running. If you write continuously, the data written later will be valid.

Bit	31	30	29	28	27	26	25	24	23	22	21	20	19	18	17	16
	CRTTIM E31	CRTTIM E30	CRTTIM E29	CRTTIM E28	CRTTIM E27	CRTTIM E26	CRTTIM E25	CRTTIM E24	CRTTIM E23	CRTTIM E22	CRTTIM E21	CRTTIM E20	CRTTIM E19	CRTTIM E18	CRTTIM E17	CRTTIM E16
Initial Value	0	0	0	0	0	0	0	0	0	0	0	0	0	0	0	0
	R/W	R/W	R/W	R/W	R/W	R/W	R/W	R/W	R/W	R/W	R/W	R/W	R/W	R/W	R/W	R/W
Bit	15	14	13	12	11	10	9	8	7	6	5	4	3	2	1	0
	CRTTIM E15	CRTTIM E14	CRTTIM E13	CRTTIM E12	CRTTIM E11	CRTTIM E10	CRTTIM E9	CRTTIM E8	CRTTIM E7	CRTTIM E6	CRTTIM E5	CRTTIM E4	CRTTIM E3	CRTTIM E2	CRTTIM E1	CRTTIM E0
Initial Value	0	0	0	0	0	0	0	0	0	0	0	0	0	0	0	0
	R/W	R/W	R/W	R/W	R/W	R/W	R/W	R/W	R/W	R/W	R/W	R/W	R/W	R/W	R/W	R/W

Bit	Bit Name	Initial Value	R/W	Description
31 to 0	CRTTIME [31:0]	All 0	R/W	Watchdog timer count value. It cannot be written while the watchdog timer is running.

CAUTION

When setting a value in the WDTTIM register, do not set a value that is WDTSET[31:0] register + H'000F_FFFF.

21.3.4 WDT Interrupt Control Register_n (WDTINT_n (n = 0))

This register reads the interrupt status of the watchdog timer, clears interrupts, and clears the counters that compose the watchdog timer. Set the INTDISP bit of this register to “1” within the time set by WDTSET. If not set, the WDTINT pin is asserted. After that, within the time set by WDTSET

When the INTDISP bit is not set to “1”, the WDTRSTB pin is asserted.

When performing continuous write access to the WDTINT register, leave a write interval of $5 \times P0\phi + 5 \times OSCCLK$ or more. If the write interval is not observed, the register will not be written.

Bit	31	30	29	28	27	26	25	24	23	22	21	20	19	18	17	16
	—	—	—	—	—	—	—	—	—	—	—	—	—	—	—	—
Initial Value	0	0	0	0	0	0	0	0	0	0	0	0	0	0	0	0
R/W	R	R	R	R	R	R	R	R	R	R	R	R	R	R	R	R
Bit	15	14	13	12	11	10	9	8	7	6	5	4	3	2	1	0
	—	—	—	—	—	—	—	—	—	—	—	—	—	—	—	INTDISP
Initial Value	0	0	0	0	0	0	0	0	0	0	0	0	0	0	0	0
R/W	R	R	R	R	R	R	R	R	R	R	R	R	R	R	R	R/W

Bit	Bit Name	Initial Value	R/W	Description
31 to 1	—	All 0	R	Reserved When read, the initial value is read. The written value will be ignored.
0	INTDISP	0	R/W	Register for interrupt status read and clear Read: Interrupt status 1: With interrupt 0: Without interrupt Write: Interrupt clear 1: Interrupt clear 0: Invalid (no change)

21.3.5 Parity Error Control Register_n (PECR_n (n = 0))

This register controls whether a reset (WDTRSTB) or an interrupt (PERROUT) is generated due to a CPU parity error.

Bit	31	30	29	28	27	26	25	24	23	22	21	20	19	18	17	16
	PECR3 1	PECR3 0	PECR2 9	PECR2 8	PECR2 7	PECR2 6	PECR2 5	PECR2 4	PECR2 3	PECR2 2	PECR2 1	PECR2 0	PECR1 9	PECR1 8	PECR1 7	PECR1 6
Initial Value	0	0	0	0	0	0	0	0	0	0	0	0	0	0	0	0
R/W	R/W	R/W	R/W	R/W	R/W	R/W	R/W	R/W	R/W	R/W	R/W	R/W	R/W	R/W	R/W	R/W
Bit	15	14	13	12	11	10	9	8	7	6	5	4	3	2	1	0
	PECR1 5	PECR1 4	PECR1 3	PECR1 2	PECR1 1	PECR1 0	PECR9	PECR8	PECR7	PECR6	PECR5	PECR4	PECR3	PECR2	PECR1	PECR0
Initial Value	0	0	0	0	0	0	0	0	0	0	0	0	0	0	0	0
R/W	R/W	R/W	R/W	R/W	R/W	R/W	R/W	R/W	R/W	R/W	R/W	R/W	R/W	R/W	R/W	R/W

Bit	Bit Name	Initial Value	R/W	Description
31 to 0	PECR [31:0]	All 0	R/W	Parity error control Controls the following operations when the value is 1 for each bit of PESR[31:0] 0: Reset (WDTRSTB) is generated 1: Generate interrupt (PEEROUT)

21.3.6 Parity Error Forced Enable Register_n (PEEN_n (n = 0))

This register forcibly asserts reset (WDTRSTB) or PERROUT even when no CPU parity error has occurred.

Bit	31	30	29	28	27	26	25	24	23	22	21	20	19	18	17	16
	—	—	—	—	—	—	—	—	—	—	—	—	—	—	—	—
Initial Value	0	0	0	0	0	0	0	0	0	0	0	0	0	0	0	0
R/W	R	R	R	R	R	R	R	R	R	R	R	R	R	R	R	R
Bit	15	14	13	12	11	10	9	8	7	6	5	4	3	2	1	0
	—	—	—	—	—	—	—	—	—	—	—	—	—	—	—	PEEN
Initial Value	0	0	0	0	0	0	0	0	0	0	0	0	0	0	0	0
R/W	R	R	R	R	R	R	R	R	R	R	R	R	R	R	R	R/W

Bit	Bit Name	Initial Value	R/W	Description
31 to 1	—	All 0	R	Reserved When read, the initial value is read. The written value will be ignored.
0	PEEN	0	R/W	Parity error forced enable 0: Reset (WDTRSTB) or PERROUT generation follows the operation of the parity error register 1: Force reset (WDTRSTB) or assert PERROUT

21.3.7 Parity Error Status Register_n (PESR_n (n = 0))

This register holds the cause of CPU parity error.

Bit	31	30	29	28	27	26	25	24	23	22	21	20	19	18	17	16
	PESR31	PESR30	PESR29	PESR28	PESR27	PESR26	PESR25	PESR24	PESR23	PESR22	PESR21	PESR20	PESR19	PESR18	PESR17	PESR16
Initial Value	0	0	0	0	0	0	0	0	0	0	0	0	0	0	0	0
R/W	R/W	R/W	R/W	R/W	R/W	R/W	R/W	R/W	R/W	R/W	R/W	R/W	R/W	R/W	R/W	R/W
Bit	15	14	13	12	11	10	9	8	7	6	5	4	3	2	1	0
	PESR15	PESR14	PESR13	PESR12	PESR11	PESR10	PESR9	PESR8	PESR7	PESR6	PESR5	PESR4	PESR3	PESR2	PESR1	PESR0
Initial Value	0	0	0	0	0	0	0	0	0	0	0	0	0	0	0	0
R/W	R/W	R/W	R/W	R/W	R/W	R/W	R/W	R/W	R/W	R/W	R/W	R/W	R/W	R/W	R/W	R/W

Bit	Bit Name	Initial Value	R/W	Description
31 to 0	PESR[31:0]	All 0	R/W	Parity error flag 0 to 31 Indicates that a parity error has occurred. Read: Interrupt status 1: With interrupt 0: Without interrupt Write: Interrupt clear 1: Interrupt clear 0: Invalid (nothing changed)

21.3.8 Parity Error Enable Register_n (PEER_n (n = 0))

This register controls the assertion of the WDTRSTB signal and PERROUT signal due to a CPU parity error. Each bit controls the behavior of parity error.

Bit	31	30	29	28	27	26	25	24	23	22	21	20	19	18	17	16
	PEER31	PEER30	PEER29	PEER28	PEER27	PEER26	PEER25	PEER24	PEER23	PEER22	PEER21	PEER20	PEER19	PEER18	PEER17	PEER16
Initial Value	0	0	0	0	0	0	0	0	0	0	0	0	0	0	0	0
R/W	R/W	R/W	R/W	R/W	R/W	R/W	R/W	R/W	R/W	R/W	R/W	R/W	R/W	R/W	R/W	R/W

Bit	15	14	13	12	11	10	9	8	7	6	5	4	3	2	1	0
	PEER15	PEER14	PEER13	PEER12	PEER11	PEER10	PEER9	PEER8	PEER7	PEER6	PEER5	PEER4	PEER3	PEER2	PEER1	PEER0
Initial Value	0	0	0	0	0	0	0	0	0	0	0	0	0	0	0	0
R/W	R/W	R/W	R/W	R/W	R/W	R/W	R/W	R/W	R/W	R/W	R/W	R/W	R/W	R/W	R/W	R/W

Bit	Bit Name	Initial Value	R/W	Description
31 to 0	PEER[31:0]	All 0	R/W	Parity error enable 31-0 Controls the operation of PESR. 0: Disables reset (WDTRSTB) and PERROUT generation operations 1: Permits reset (WDTRSTB) and PERROUT generation operation

21.3.9 Parity Error Polarity Setting Register_n (PEPO_n (n = 0))

This register sets the polarity of CPU parity error.

Bit	31	30	29	28	27	26	25	24	23	22	21	20	19	18	17	16
	PEPO3 1	PEPO3 0	PEPO2 9	PEPO2 8	PEPO2 7	PEPO2 6	PEPO2 5	PEPO2 4	PEPO2 3	PEPO2 2	PEPO2 1	PEPO2 0	PEPO1 9	PEPO1 8	PEPO1 7	PEPO1 6
Initial Value	0	0	0	0	0	0	0	0	0	0	0	0	0	0	0	0
R/W	R/W	R/W	R/W	R/W	R/W	R/W	R/W	R/W	R/W	R/W	R/W	R/W	R/W	R/W	R/W	R/W
Bit	15	14	13	12	11	10	9	8	7	6	5	4	3	2	1	0
	PEPO1 5	PEPO1 4	PEPO1 3	PEPO1 2	PEPO1 1	PEPO1 0	PEPO9	PEPO8	PEPO7	PEPO6	PEPO5	PEPO4	PEPO3	PEPO2	PEPO1	PEPO0
Initial Value	0	0	0	0	0	0	0	0	0	0	0	0	0	0	0	0
R/W	R/W	R/W	R/W	R/W	R/W	R/W	R/W	R/W	R/W	R/W	R/W	R/W	R/W	R/W	R/W	R/W

Bit	Bit Name	Initial Value	R/W	Description
31 to 0	PEPO [31:0]	All 0	R/W	Active polarity of parity 31-0 Set the Active polarity (H/L) of each parity error signal connected to PEERR. 0: Active High 1: Active Low

21.3.10 Register Setting Order for Each WDT Channel

The following shows the register setting sequence for controlling the watchdog timer and parity error circuit of each channel. The control of the original watchdog timer and the parity error circuit do not affect each other, so there is no restriction on the setting order in the following diagrams (1) and (2).

The parity error circuit cannot accept the parity error that occurred before setting PEER = 1. When rewriting PEEN from 0 to 1, it is possible to rewrite at any timing. However, when rewriting PEEN from 1 to 0, once PEER = 0 and (2) flow execution is required.

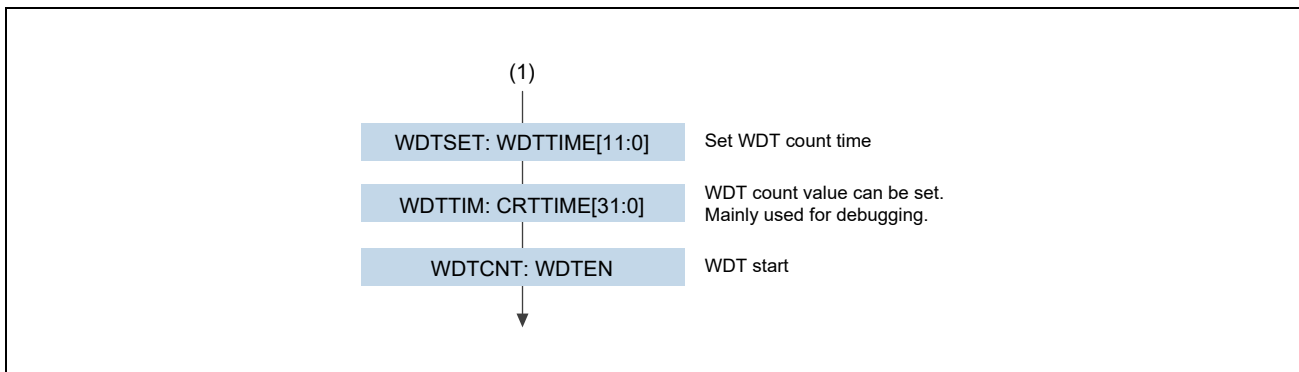

Figure 21.3 WDT Register Setting Order

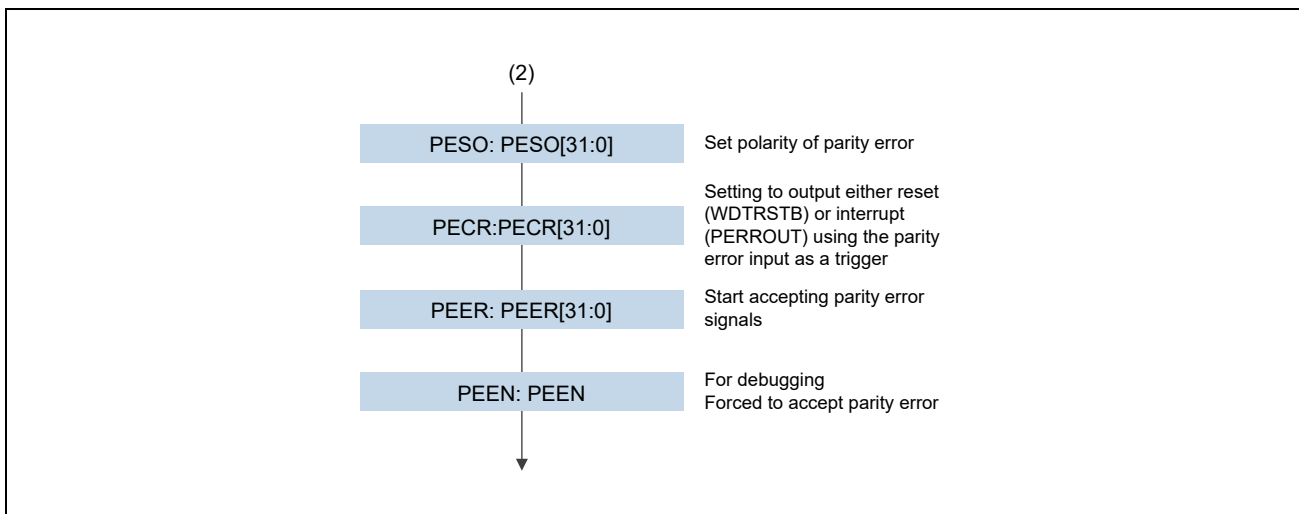

Figure 21.4 Parity Error Circuit Register Setting Order

21.4 Operation

21.4.1 WDT_CORE Operaton Timing

Figure 21.5 shows the operation diagram of the WDT-Core block. When 1 is set in Bit [0] of the WDTCNT register, the 32-bit internal counter WDT-Counter starts counting. If the counter value matches the value set in the WDTSET register, the counter becomes overflow, clears the counter to 0, and then generates an interrupt request signal.

An interrupt signal is output at the first counter overflow, and a reset request signal is output if the counter is not cleared and the second counter overflow occurs.

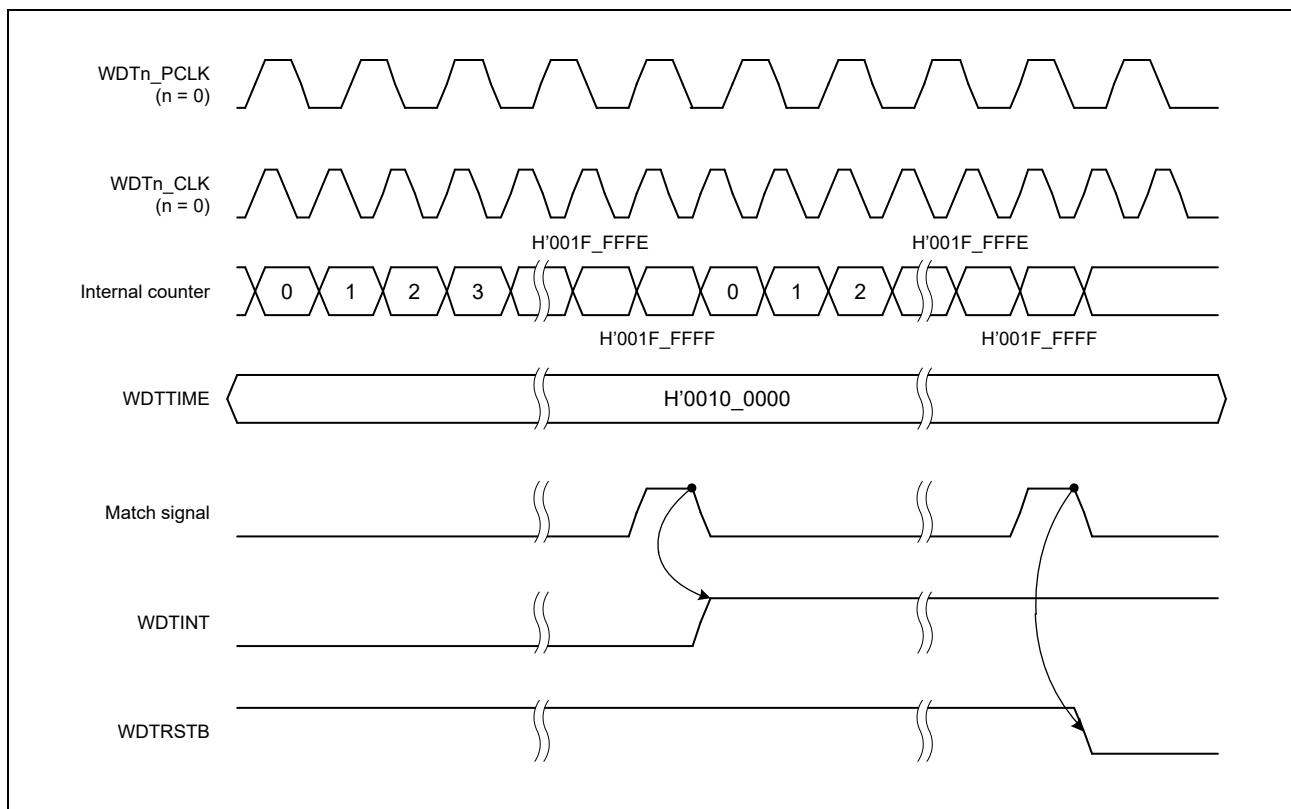

Figure 21.5 WDT Output Signal Operation Timing

21.4.2 WDT Interrupt Control Register (WDTINT) Specification for Write Access Interval

After the write access to the WDT interrupt control register is completed, the written data is synchronized with WDTn_CLK ($n = 0$), so a synchronization period is required. When performing write access to the WDTINT register, it is necessary to leave a write interval of $5 \times P0\phi + 5 \times OSCCLK$ or more between the next write access.*¹

Note 1. If the write interval is not observed, the interrupt request may not be cleared.

In this case, after making a write access and confirming that the interrupt factor has been cleared, perform the following write access.

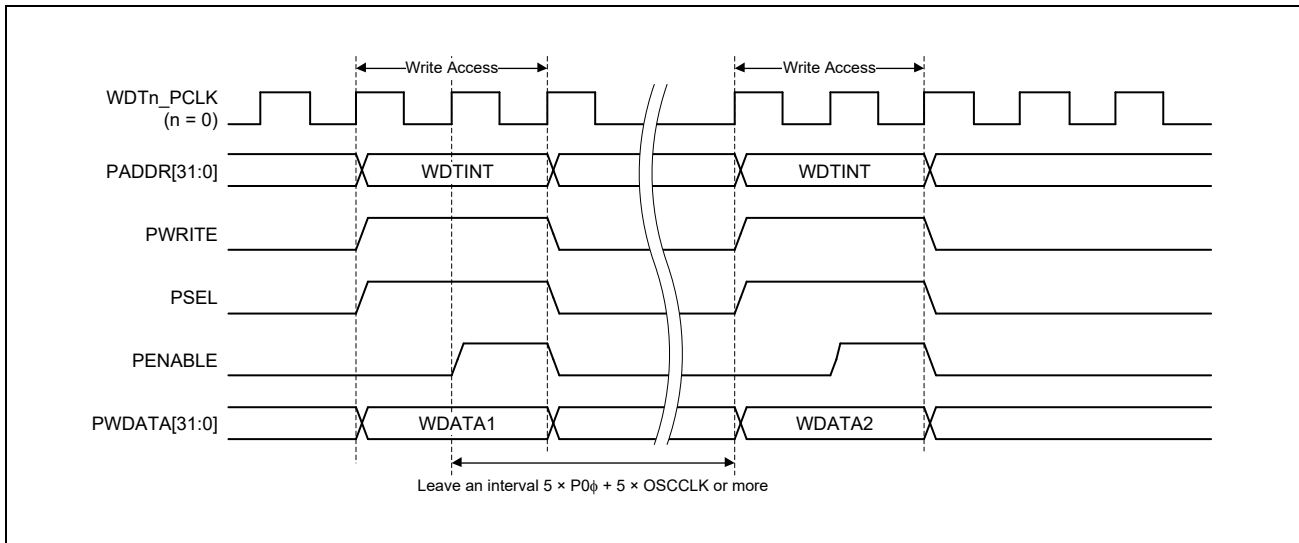

Figure 21.6 WDTINT Write Access Interval Regulation

21.4.3 Watchdog Timer Operation Reflection Timing of Register Setting Value

Each register other than the WDT interrupt control register (WDTINT) is always synchronized with WDTn_CLK (n = 0) at regular intervals. The timing at which the written data is reflected in the watchdog timer operation is in the range of small $2 \times P0\phi + 4 \times OSCCLK$ to large value ($6 \times P0\phi + 9 \times OSCCLK$).

Figure 21.7 (Watchdog timer operation reflection timing 1 of register setting value) shows how write data is small and synchronized.

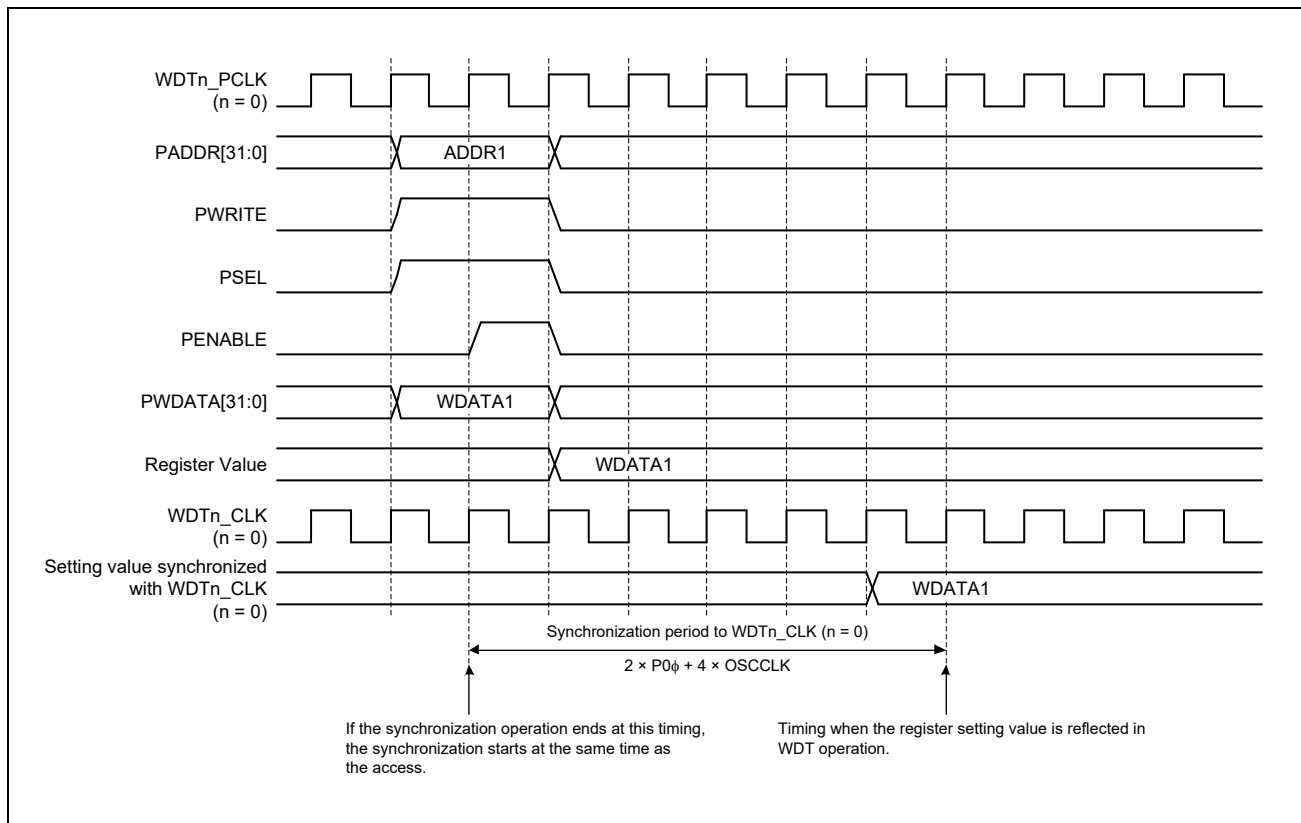

Figure 21.7 Watchdog Timer Operation Reflection Timing of Register Setting Value - 1

In addition, **Figure 21.8** (Watchdog timer operation reflection timing 2 of register setting value) shows how write data is large and synchronized.

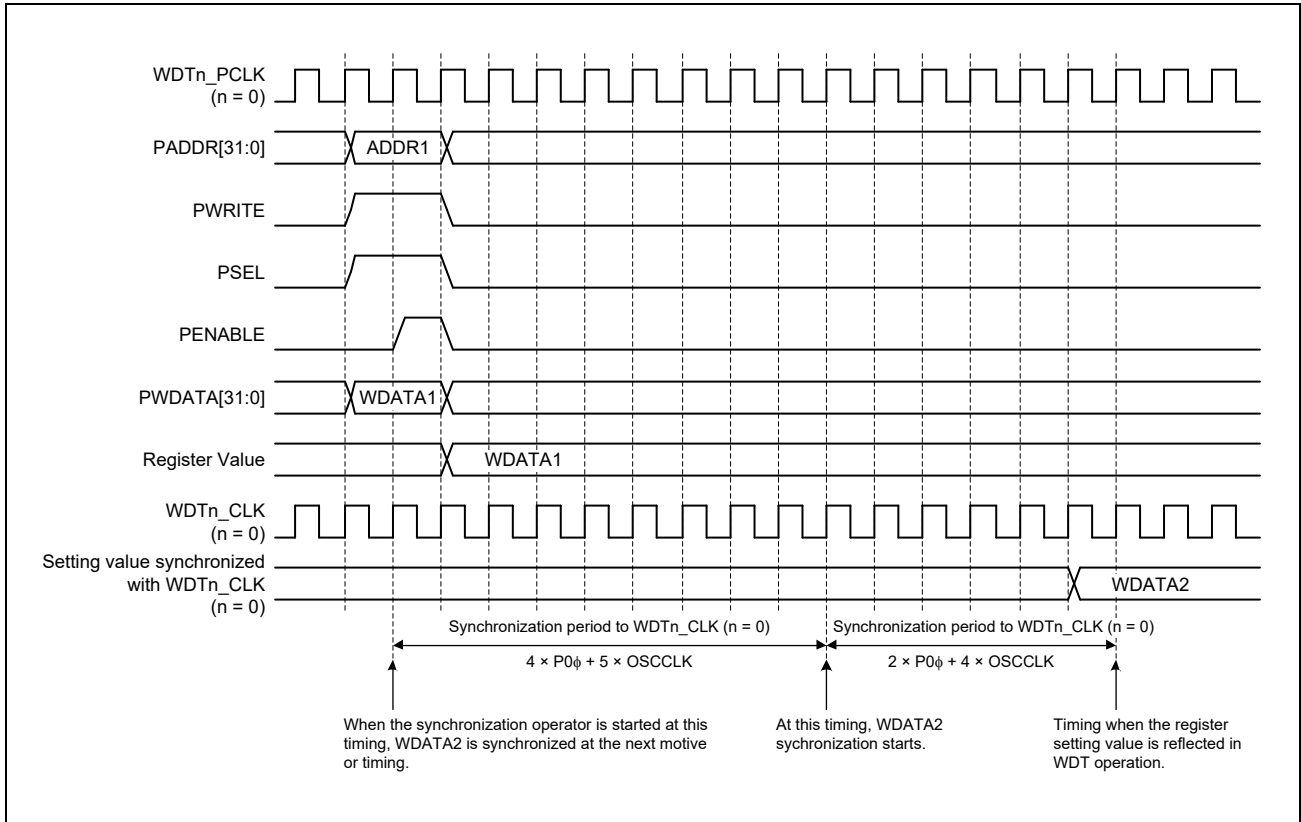

Figure 21.8 Watchdog Timer Operation Reflection Timing of Register Setting Value - 2

21.4.4 Timing of Reflecting WDT Counter Value to WDTTIM Register

The value stored in the WDTTIM register is the value obtained by synchronizing the counter value with P0φ. Therefore, the interval at which the value is updated in the WDTTIM register is $5 \times \text{OSCCLK} + 5 \times \text{P0}\phi$ at most, and the value before the actual counter value is read.

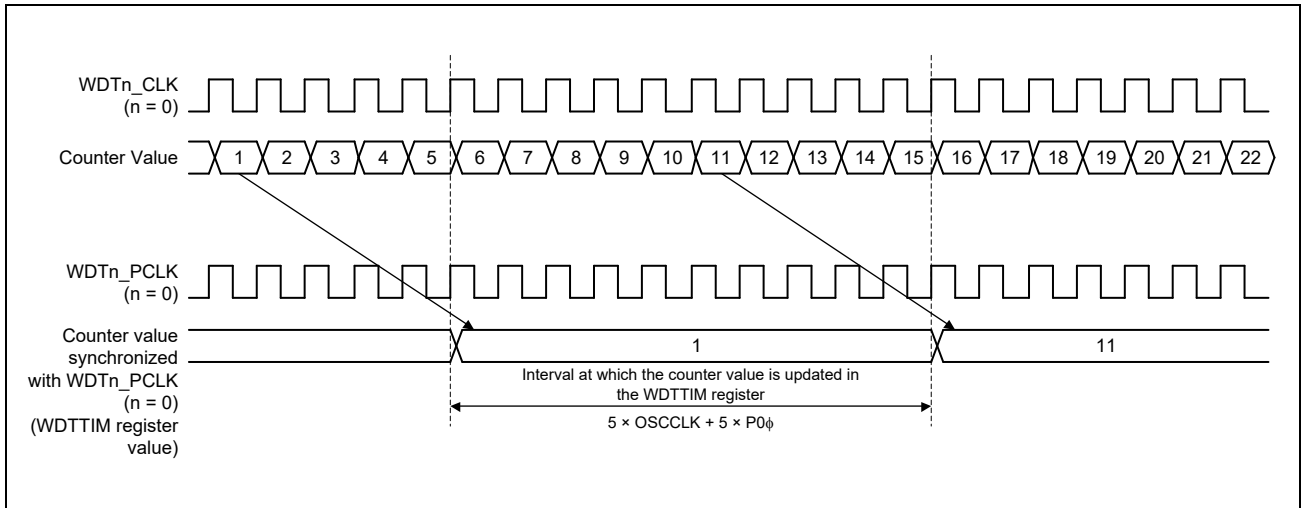

Figure 21.9 Timing of Reflecting the Counter Value to the WDTTIM Register

21.4.5 Conditions Under which WDTRSTB and PERROUT Operate

Table 21.5 shows the conditions under which WDTRSTB and PERROUT operate.

When PEER = 0, WDTRSTB follows the watchdog timer operation described in **Section 21.4.1** to **Section 21.4.5** regardless of the occurrence of parity error. PERROUT holds 0. (No. 1, No. 2) No. 3 to No. 6 show the operating conditions when the parity error input is enabled by PEER = 1. When a parity error occurs (No. 3, No. 4), PESR holds the error status, and WDTRSTB or PERROUT is asserted depending on the value of PECR. If no parity error occurs, PESR = 0, WDTRSTB propagates the WDT-Core logic, and PERROUT is in the unasserted state. (No. 5, No. 6) When PEEN = 1 forces a parity error to occur, WDTRSTB or PERROUT is asserted depending on the PECR value regardless of the parity error.

Table 21.5 WDTRSTB/PERROUT Operating Conditions

No.	PEERR	PEPO	PEER	PEEN	PECR	PESR	WDTRSTB	PERROUT
1	X	1/0	0	0	0	0 (Fixed)	Original WDT	0: de-assert
2		1/0	0	0	1	0 (Fixed)	Original WDT	0: de-assert
3	With parity	1/0	1	0	0	1	0: assert	0: de-assert
4		1/0	1	0	1	1	Original WDT	1: assert
5	No parity	1/0	1	0	0	0	Original WDT	0: de-assert
6		1/0	1	0	1	0	Original WDT	0: de-assert
7	X	X	X	1	0	X	0: assert	0: de-assert
8		X	X	1	1	X	Original WDT	1: assert

The timing waveforms for No. 1 to No. 4 in **Table 21.5** are shown below.

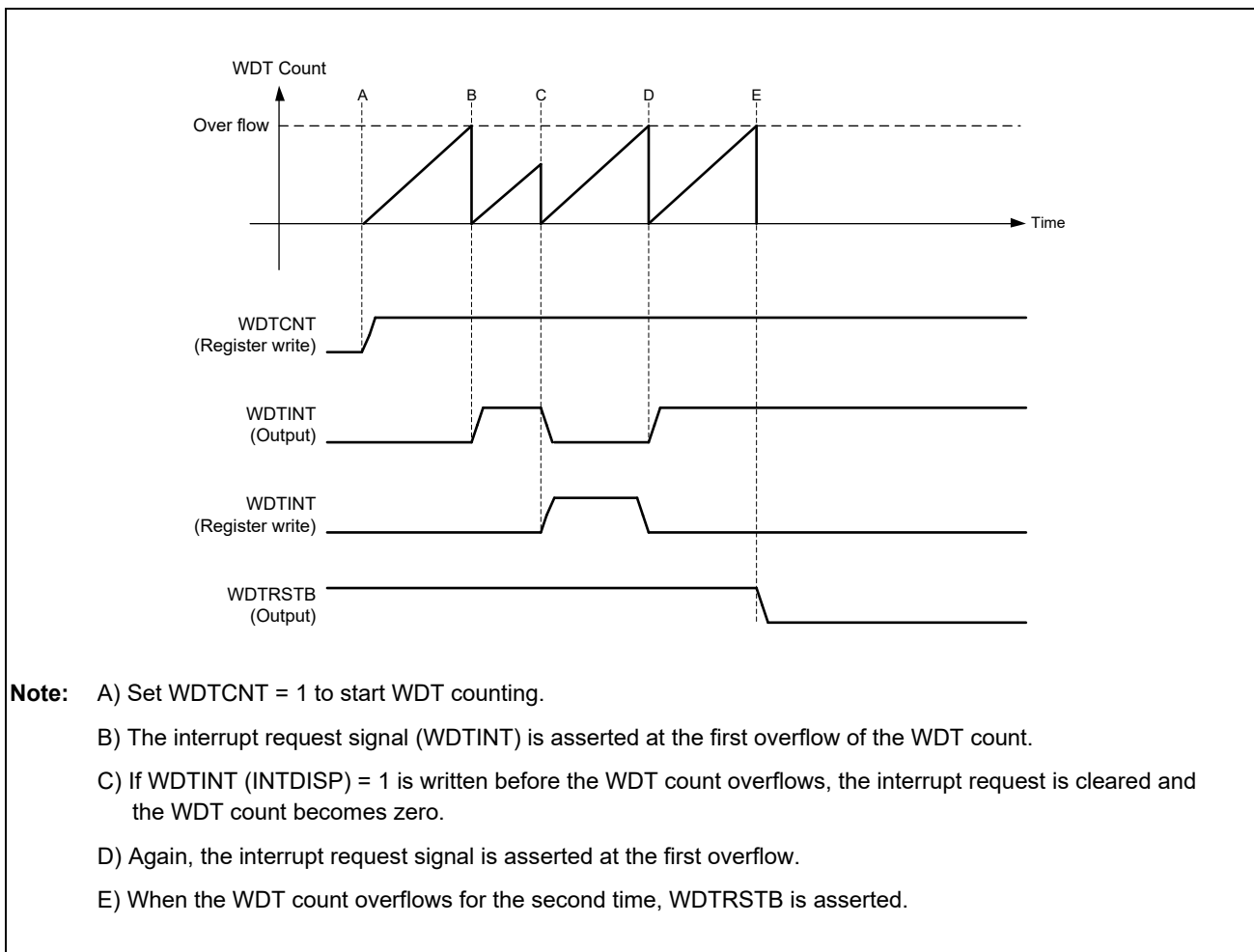
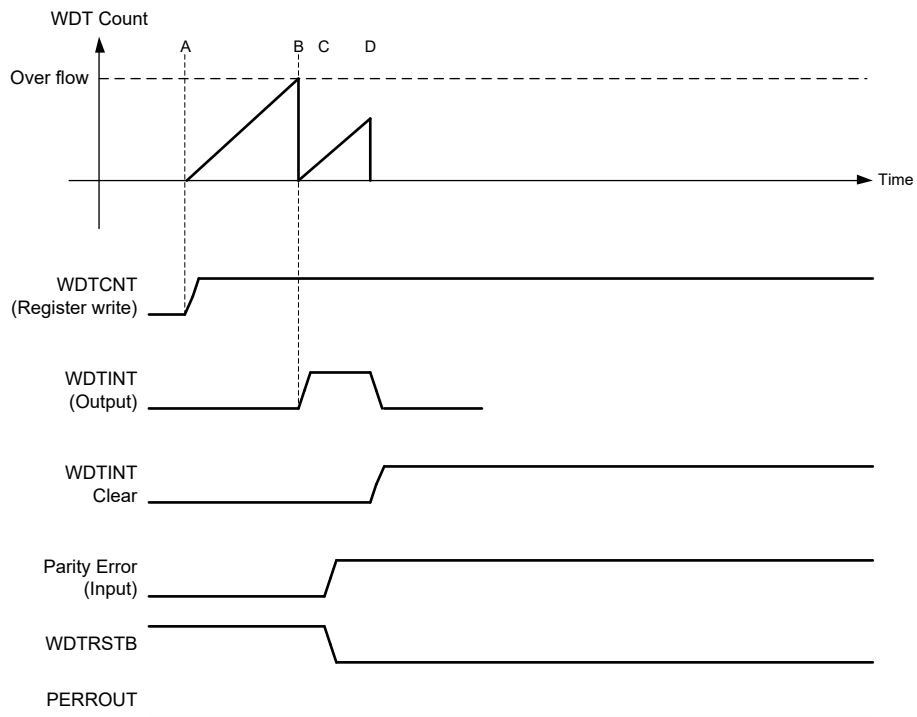
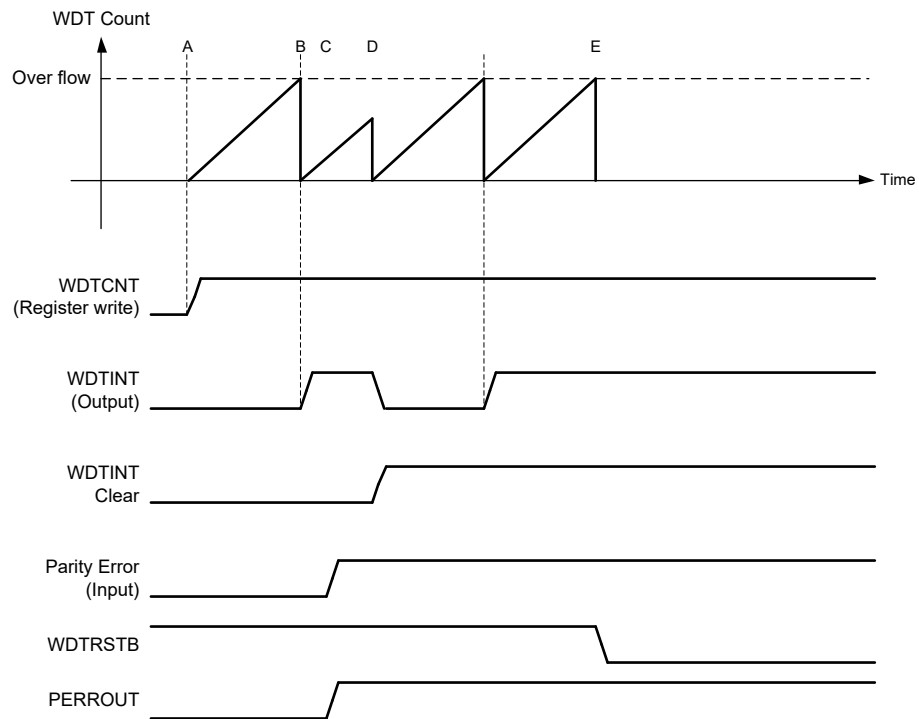

Figure 21.10 Normal Watchdog Timer Operation No. 1/No. 2



- Note:**
- A) Set WDCNT = 1 to start WDT counting.
 - B) The interrupt request signal (WDTINT) is asserted at the first overflow of the WDT count.
 - C) When a parity error occurs, WDTRSTB = 0. At the same time, hold PERROUT = 0.
 - D) Even if WDTCount is reset by WDTINT = 1, WDTRSTB = 0 and PERROUT = 0 are retained.

Figure 21.11 Watchdog Timer Operation when a Parity Error Signal Occurs No. 3



- Note:**
- A) Set WDCNT = 1 to start WDT counting.
 - B) The interrupt request signal (WDTINT) is asserted at the first overflow of the WDT count.
 - C) When a parity error occurs, WDTRSTB = 1. At the same time, hold PERROUT = 1.
 - D) Even if WDTCount is reset by WDTINT = 1, WDTRSTB = 1 and PERROUT = 1 are retained.
 - E) WDTRSTB = 0 is asserted due to WDT Count overflow.

Figure 21.12 Watchdog Timer Operation when a Parity Error Signal Occurs No. 4

21.5 Reset Control

21.5.1 WDTRST Control of Each WDT Channels

WDT CH0 generates WDTINT every cycle set in WDTSET. The CPU (AX45MP) receives the WDT CH0 interrupt signal WDTINT, clears the WDT CH0 counter at regular intervals, and suppresses the overflow of the WDT counter.

If the counter is not cleared before the cycle set for each WDT elapses, the uncleared WDT sends a reset request signal to the CPG. Based on the setting of the built-in register CPG_WDTRST_SEL, CPG can select whether to reset only the CPU corresponding to the WDT that caused the reset from the WDT reset request signal from each channel, or to reset the entire system. is. You can also choose whether to assert the WDTOVF_PERROUT# pin to notify the outside world that the entire system has been reset.

(For details about CPG_WDTRST_SEL register in CPG, refer to the CPG chapter.)

Table 21.6 WDT Reset Target by CPG_WDTRST_SEL Register

Bit	Initial Value	R/W	Reset Factor	Function
CPG_WDTRST_SEL[0]	0	R/W	WDT CH0	When the target WDT executes a reset request due to overflow etc. 0: Mask system reset 1: System reset implementation
CPG_WDTRST_SEL[4]	0	R/W	WDT CH0	When the target WDT executes a reset request due to overflow etc. 0: Mask WDTOVF_PERROUT assert 1: WDTOVF_PERROUT assert
CPG_WDTRST_SEL[8]	0	R/W	WDT CH0	When either WDT CH0 makes a reset request 0: Mask the Cold-Reset of AX45MP 1: Implemented AX45MP Cold-Reset

When the WDT system reset is executed, it is also possible to set the CPG_WDTRST_SEL[4] bit to notify the system outside the LSI from the WDTOVF_PERROUT# pin of the GPIO pin that the system reset has occurred due to the WDT overflow. When using WDTOVF_PERROUT# as a signal to notify the system reset to the outside, set the CPG_WDTRST_SEL[4] bit to 1 when CPG_WDTRST_SEL[0] is 1 as shown below.

CPG_WDTRST_SEL[4] Set 1 when CPG_WDTRST_SEL[0] = 1

For example, if CPG_WDTRST_SEL[0] = 0 and WDTRST_SEL[4] = 1 are set, the system reset will not be executed even if WDT CH0 asserts a reset request because CPG_WDTRST_SEL[0] = 0, but WDTRST_SEL[4] = 1 so WDTOVF_PERROUT# pin will be asserted. In other words, the system reset execution status and WDTOVF_PERROUT do not match.

21.6 Usage Note

[Cautions]

- When setting a value in the WDTTIM register, do not set a value that is WDTSET register + H'F_FFFF.
- The reset request signal WDTRSTB and WDT interrupt signal WDTINT cannot be masked.

22. Serial Communications Interface with FIFO (SCIFA)

This LSI has five channels of serial communication interface (SCIFA) with FIFO that support both asynchronous and clock synchronous serial communication. The SCIFA has 16-stage FIFO buffers for transmission and reception, respectively, for each channel that enable this LSI to perform efficient high-speed continuous communication.

22.1 Overview

Table 22.1 lists the specifications of the SCIFA.

Table 22.1 Specifications of SCIFA

Item	Description	
Channel	5 channels (ch 0,1,2,3,4)	
Serial communication method	Asynchronous communication mode and clock synchronous communication mode	
Transfer speed	Selectable bit rate with an on-chip baud rate generator	
Full duplex communication	Transmitting section: realizes continuous data transmission using 16-stage FIFO buffer Receiving section: realizes continuous data reception using 16-stage FIFO buffer	
Data transmission	Selectable either LSB-first or MSB-first transfer	
Interrupt source	The following six sources: <ul style="list-style-type: none"> • Transmit-end (TEIF) • Transmit-FIFO-data-empty (TXIF) • Receive-FIFO-data-full (RXIF) • Receive-data-ready (DRIF)*1 • Receive-error (ERIF) • Break detection or overrun (BRIF) 	
Asynchronous communication mode	Character length	7 or 8 bits
	Transmission stop bit length	1 or 2 bits
	Parity	Even, odd, or none
	Receive error detection	Parity, overrun, and framing errors
	Hardware flow control	Controls data transmission and reception using the CTS# and RTS# pins. Not applicable to channel 3 (SCIF3) and channel 4 (SCIF4)
	Break detection	Break signal detection function by hardware.
	Clock source	Selectable from internal or external clock
	Noise cancellation	Incorporates a digital noise filter in the RXD pin input path.
Clock synchronous communication mode	Character length	8 bits
	Receive error detection	Detects an overrun error as a receive error.
	Clock source	Selectable either internal or external clock
Bit rate modulation	Enables errors to be decreased by correcting the output of the on-chip baud rate generator.	

Note 1. Effective only for asynchronous communication mode

Figure 22.1 shows a block diagram of the SCIFA.

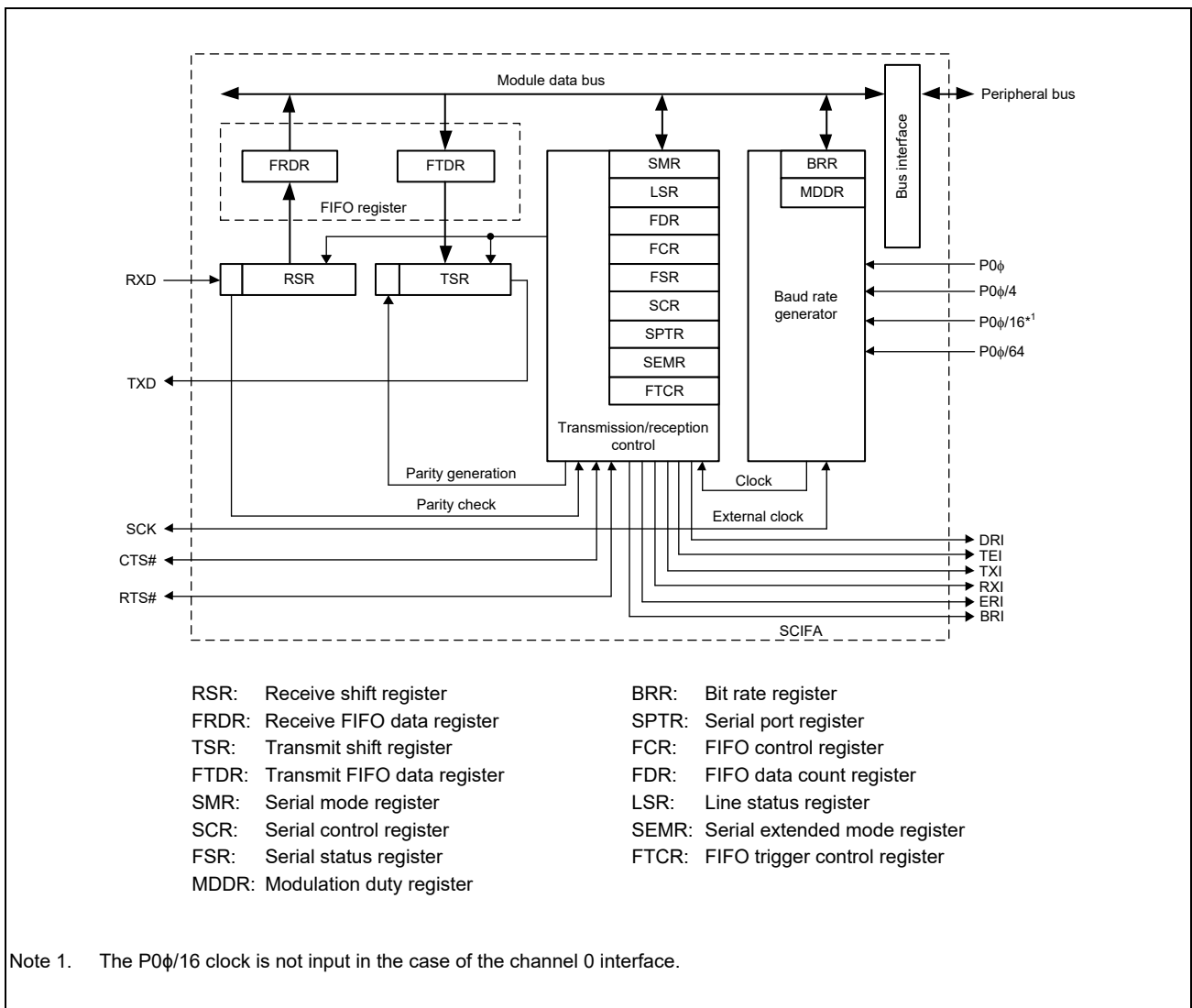

Figure 22.1 Block Diagram of SCIFA

Table 22.2 lists the input/output pins of the SCIFA.

Table 22.2 Pin Configuration of the SCIFA

Channel	Item	Pin Name	I/O	Function
0 to 4 (n = 0-4)	Serial clock pin	SCIFn_SCK	I/O	Transmission/reception clock input/output, general output
	Receive data pin	SCIFn_RXD	Input	Receive data input
	Transmit data pin	SCIFn_TXD	Output	Transmit data output
0 to 2 (n = 0-2)	Transmission/reception start control pin	SCIFn_CTS#	I/O	Input for hardware flow control (transmission enable signal) / general output
		SCIFn_RTS#	Output	Output for hardware flow control (transmission request signal) / general output

Note: Channels of each pin is omitted.

22.2 Register Descriptions

Table 22.3 Base Address Table

Address Space	Channel 0	Channel 1	Channel 2	Channel 3	Channel 4
AX45MP Address Space	H'0_1004_B800	H'0_1004_BC00	H'0_1004_C000	H'0_1004_C400	H'0_1004_C800

Table 22.4 List of Registers

Register Name	Abbreviation	R/W	Initial Value	Offset Address	Access Size
Serial mode register	SMR	R/W	H'0000	H'00	16
Bit rate register	BRR	R/W	H'FF	H'02	8
Modulation duty register	MDDR	R/W	H'FF	H'02	8
Serial control register	SCR	R/W	H'0000	H'04	16
Transmit FIFO data register	FTDR	W	Undefined	H'06	8
Serial status register	FSR	R/W	H'0020	H'08	16
Receive FIFO data register	FRDR	R	Undefined	H'0A	8
FIFO control register	FCR	R/W	H'0000	H'0C	16
FIFO data count register	FDR	R	H'0000	H'0E	16
Serial port register	SPTR	R/W	H'00xx	H'10	16
Line status register	LSR	R/W	H'0000	H'12	16
Serial extended mode register	SEMR	R/W	H'00	H'14	8
FIFO trigger control register	FTCR	R/W	H'1F1F	H'16	16

Note: BRR and MDDR are located in the same address. Setting the MDDRS bit of the SEMR register switches these registers.

22.2.1 Receive Shift Register (RSR)

The RSR register receives serial data and temporally stores the data. The SCIFA stores the serial data input via the RXD pin into the RSR register and converts the data to the parallel form. When one byte of data has been received, it is automatically transferred to the receive FIFO data register (FRDR).

The CPU cannot read from or write to the RSR register directly.

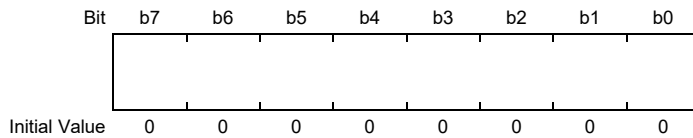

22.2.2 Receive FIFO Data Register (FRDR)

The FRDR register is a 8-bit, 16-stage FIFO register that stores the received serial data. When the SCIFA receives one byte of serial data, it transfers the received data from the receive shift register (RSR) to the FRDR register and completes the receive operation. Continuous reception is possible until the received 16 bytes of data are stored. If the FRDR register is read when there is no received data in the FRDR register, an undefined value is read.

When the FRDR register is full of received data, subsequently received serial data is lost.

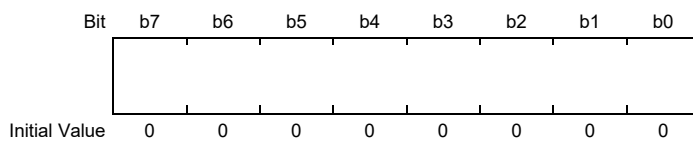

22.2.3 Transmit Shift Register (TSR)

The SCIFA transfers the transmit data from the transmit FIFO data register (FTDR) to the TSR register, and then transmits the data serially to the TXD pin. After transmitting one byte of data, the SCIFA automatically transfers the next transmit data from the FTDR register into the TSR register and starts transmission.

The CPU cannot read from or write to the TSR register directly.

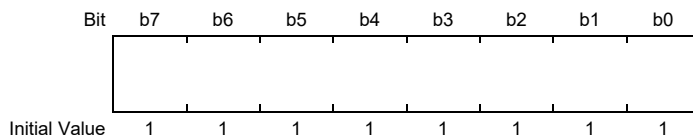

22.2.4 Transmit FIFO Data Register (FTDR)

The FTDR register is a 8-bit, 16-stage FIFO register that stores serial transmission data. When the SCIFA detects that the transmit shift register (TSR) is empty, it transmits data written in the FTDR register to the TSR register and starts serial transmission. Continuous serial transmission is executed until there is no transmit data left in the FTDR register. Writing the transmit data to the FTDR register should be done when a transmit data empty interrupt (TXI) request is generated. When the FTDR register becomes full of transmit data (16 bytes), no more data can be written. Even if new data is written, the data is ignored.

CPU can read from the FTDR register but cannot write to it.

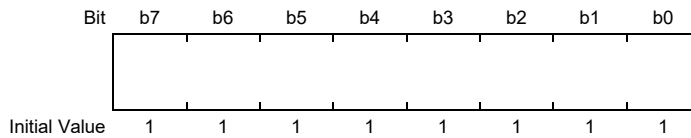

22.2.5 Serial Mode Register (SMR)

The SMR register specifies the SCIFA serial communication format and selects the clock source for the baud rate generator.

The CPU can always read and write to the SMR register.

Bit	b15	b14	b13	b12	b11	b10	b9	b8	b7	b6	b5	b4	b3	b2	b1	b0
	—	—	—	—	—	—	—	—	CM	CHR	PE	PM	STOP	—	CKS[1:0]	
Initial Value	0	0	0	0	0	0	0	0	0	0	0	0	0	0	0	0
	R/W	R/W	R/W	R/W	R/W	R/W	R/W	R/W	R/W	R/W	R/W	R/W	R/W	R/W	R/W	R/W

Bit	Bit Name	Initial Value	R/W	Description
b1, b0	CKS[1:0]	All 0	R/W	Clock Select b1 b0 0 0: $1 \times P0\phi^{*1}$ 0 1: $1/4 \times P0\phi^{*1}$ 1 0: $1/16 \times P0\phi^{*1,*2}$ 1 1: $1/64 \times P0\phi^{*1}$
b2	—	0	R/W	Reserved This bit is read as 0. The write value should be 0.
b3	STOP	0	R/W	Stop Bit Length 0: One stop bit 1: Two stop bits
b4	PM	0	R/W	Parity Mode 0: Even parity 1: Odd parity
b5	PE	0	R/W	Parity Enable 0: Parity bit addition or check is disabled. 1: Parity bit addition or check is enabled.
b6	CHR	0	R/W	Character Length 0: 8-bit data 1: 7-bit data*3
b7	CM	0	R/W	Communication Mode 0: Asynchronous mode 1: Clock synchronous mode
b15 to b8	—	All 0	R/W	Reserved These bits are read as 0. The write value should be 0.

Note 1. $P0\phi$: SCIFn_CLK_PCK (n = 0 to 4)

Note 2. This setting is not applicable to channel 0. It is only applicable to channels 1 to 4.

Note 3. When 7-bit data is selected, the MSB (bit 7) of the transmit FIFO data register is not transmitted.

CKS[1:0] Bits (Clock Select)

Select an internal clock source for the on-chip baud rate generator. For further information on the clock source, bit rate register settings, and baud rates, see **Section 22.2.8, Bit Rate Register (BRR)**.

STOP Bit (Stop Bit Length)

Selects one bit or two bits as the stop bit length in asynchronous mode. This setting is used only in asynchronous mode. It is ignored in clock synchronous mode because no stop bits are added. When receiving, only the first stop bit is checked, regardless of the STOP bit setting. If the second stop bit is 1, it is treated as a stop bit, but if the second stop bit is 0, it is treated as the start bit of the next incoming character.

Note: When transmitting with one stop bit, a single 1 bit (stop bit) is added at the end of each transmission character.

Note: When transmitting with two stop bits, two 1 bits (stop bits) are added at the end of each transmission character.

PM Bit (Parity Mode)

Selects either the even or odd parity check. The setting of this bit is effective only when the parity enable (PE) bit of this register is set to 1 in asynchronous mode. The setting of this bit is ignored in clock synchronous mode, or when parity addition/check is disabled in asynchronous mode.

Note: If even parity is selected, the parity bit is added to data to be transmitted to make the total number of 1s even in the transmission character and parity bit combined. When receiving, the SCIFA verifies that the total number of 1s in the received character and parity bit combined is even.

Note: If odd parity is selected, the parity bit is added to data to be transmitted to make the total number of 1s odd in the transmission character and parity bit combined. When receiving, the SCIFA verifies that the total number of 1s in the received character and parity bit combined is odd.

PE Bit (Parity Enable)

Selects whether to add a parity bit on data transmission and whether to enable/disable the parity check on data reception in asynchronous mode. In clock synchronous mode, a parity bit is neither added nor checked, regardless of the setting of this bit.

Note: When this bit is set to 1, an even or odd parity bit specified in the PM bit is added to data to be transmitted. The SCIFA verifies whether the parity bit of the received data is even or odd as specified in the PM bit when receiving.

CHR Bit (Character Length)

Selects 7- or 8-bit data length in asynchronous mode. In clock synchronous mode, the data length is always 8 bits, regardless of the CHR setting.

CM Bit (Communication Mode)

Selects whether the SCIFA operates in asynchronous or clock synchronous mode.

22.2.6 Serial Control Register (SCR)

The SCR register enables or disables the SCIFA transmission/reception and interrupt requests, and selects the transmit/receive clock source. The CPU can always read from and write to the SCR register.

Bit	b15	b14	b13	b12	b11	b10	b9	b8	b7	b6	b5	b4	b3	b2	b1	b0
	—	—	—	—	—	—	—	—	TIE	RIE	TE	RE	REIE	TEIE	CKE[1:0]	
Initial Value	0	0	0	0	0	0	0	0	0	0	0	0	0	0	0	0
R/W	R/W	R/W	R/W	R/W	R/W	R/W	R/W	R/W	R/W	R/W	R/W	R/W	R/W	R/W	R/W	R/W

Bit	Bit Name	Initial Value	R/W	Description
b1, b0	CKE[1:0]	All 0	R/W	Clock Enable In asynchronous mode: b1 b0 0 0: Internal clock or SCK pin is used for input pin (input signal is ignored). The SCK pin state depends on the SCKIO and SCKDT bits in SPTR. 0 1: Internal clock or SCK pin is used for clock output (The output clock frequency is 16 or 8 times of the bit rate). 1 0: External clock or SCK pin is used for clock input (The input clock frequency is 16 or 8 times of the bit rate). 1 1: Setting prohibited In clock synchronous mode: b1 b0 0 0: Internal clock or SCK pin is used for synchronous clock output. 0 1: Internal clock or SCK pin is used for synchronous clock output. 1 0: External clock or SCK pin is used for synchronous clock input. 1 1: Setting prohibited
b2	TEIE*1	0	R/W	Transmit End Interrupt Enable 0: Transmit end interrupt (TEI) request is disabled. 1: Transmit end interrupt (TEI) request is enabled.
b3	REIE	0	R/W	Receive Error Interrupt Enable 0: Receive-error interrupt (ERI) and break interrupt (BRI) requests are disabled. 1: Receive-error interrupt (ERI) and break interrupt (BRI) requests are enabled.
b4	RE	0	R/W	Receive Enable 0: Data reception is disabled. 1: Data reception is enabled.
b5	TE	0	R/W	Transmit Enable 0: Data transmission is disabled. 1: Data transmission is enabled.
b6	RIE	0	R/W	Receive Interrupt Enable 0: Receive-FIFO-data-full interrupt (RXI), receive-data ready interrupt (DRI), receive-error interrupt (ERI), and break interrupt (BRI) requests are disabled. 1: Receive-FIFO-data-full interrupt (RXI), receive-data ready interrupt (DRI), receive-error interrupt (ERI), and break interrupt (BRI) requests are enabled.
b7	TIE	0	R/W	Transmit Interrupt Enable 0: Transmit-FIFO-data-empty interrupt request (TXI) is disabled. 1: Transmit-FIFO-data-empty interrupt request (TXI) is enabled.
b15 to b8	—	All 0	R/W	Reserved These bits are read as 0. The write value should be 0.

Note 1. TEI interrupt requests can be cleared by reading 1 from the TEND flag, and then clearing the setting to 0, or by setting the TEIE bit to 0.

CKE[1:0] Bits (Clock Enable)

Select the SCIFA clock source and enable or disable clock output from the SCK pin. Depending on the settings of these bits, the SCK pin can be used for serial clock output or serial clock input. If the SCK pin is set for the synchronous clock output in the clock synchronous mode, set the CM bit in the SMR register to 1, and then set the CKE[1:0] bits. The settings of the CKE[1:0] bits are listed in **Table 22.17**.

REIE Bit (Receive Error Interrupt Enable)

Specifies whether to enable or disable a receive-error interrupt (ERI) request and a break interrupt (BRI) request. The setting of this bit is only valid when the RIE bit is set to 0.

Note: ERI interrupt requests can be cleared by reading 1 from the ER bit in the FSR register, and then clearing the setting to 0, or by clearing both the RIE and REIE bits in this register to 0. BRI interrupt requests can be cleared by reading 1 from the BRK bit in the FSR register, or from the ORER flag in the LSR register, and then clearing the setting to 0, or by clearing both the RIE and REIE bits in this register to 0.

RE Bit (Receive Enable)

Specifies whether to enable or disable the serial data reception.

Note: Setting this bit to 0 does not affect the receive flags (DR, ER, BRK, RDF, FER, and PER in the FSR register, and ORER in the LSR register). These flags retain their previous values.

Note: Serial reception starts when a start bit is detected in asynchronous mode, or a synchronous clock input is detected in clock synchronous mode. Before setting this bit to 1, be sure to set the serial mode register (SMR) and the FIFO control register (FCR) to select the receive format and reset the receive FIFO.

TE Bit (Transmit Enable)

Specifies whether to enable or disable the serial data transmission.

Note: Serial transmission starts after writing of data to be transmitted into the FTDR register under this condition. Before setting this bit to 1, be sure to set the serial mode register (SMR) and the FIFO control register (FCR) to select the transmit format and reset the transmit FIFO.

RIE Bit (Receive Interrupt Enable)

Specifies whether to enable or disable a receive-FIFO-data-full (RXI) interrupt request when the RDF flag in the serial status register (FSR) is set to 1, a receive-data ready (DRI) interrupt request when the DR flag in the FSR register is set to 1, a receive-error (ERI) interrupt request when the ER flag in the FSR register is set to 1, and a break (BRI) interrupt request when the BRK flag in the FSR register or the ORER flag in the line status register (LSR) is set to 1.

Note: RXI interrupt requests can be cleared by reading 1 from the DR or RDF flag in the FSR register, then clearing the flag to 0, or by clearing the RIE bit to 0. DRI interrupt requests can be cleared by reading 1 from the DR flag in the FSR register, and then clearing the setting to 0, or by clearing the RIE bit in this register to 0. Receive error interrupt (ERI) requests and break interrupt (BRI) requests can be cleared by clearing both the RIE and REIE bits in this register to 0.

TIE Bit (Transmit Interrupt Enable)

Specifies whether to enable or disable a transmit-FIFO-data-empty interrupt (TXI) request when the serial transmit data is transferred from the transmit FIFO data register (FTDR) into the transmit shift register (TSR), the quantity of data in the transmit FIFO data register falls below the specified trigger number for transmission, and the TDFE flag in the serial status register (FSR) is set to 1.

Note: TXI interrupt requests can be cleared either by writing a greater quantity of transmit data than the specified transmission trigger number into the FTDR register, reading 1 from the TDFE flag, and then clearing the TDFE flag to 0, or by clearing this bit to 0.

22.2.7 Serial Status Register (FSR)

The FSR register is a 16-bit register. The 8 lower-order bits indicate the status flag representing the SCIFA operating state.

The CPU can always read and write to the FSR register, but cannot write 1 to the status flags (ER, TEND, TDFE, BRK, RDF, and DR bits) in this register. These flags can be only cleared to 0 when they have first been read (after being set to 1). b3 (FER) and b2 (PER) are read-only bits that cannot be written.

Bit	b15	b14	b13	b12	b11	b10	b9	b8	b7	b6	b5	b4	b3	b2	b1	b0
	—	—	—	—	—	—	—	—	ER	TEND	TDFE	BRK	FER	PER	RDF	DR
Initial Value	0	0	0	0	0	0	0	0	0	0	1	0	0	0	0	0
R/W	R/W	R/W	R/W	R/W	R/W	R/W	R/W	R/W	R/(W)*1	R/(W)*1	R/(W)*1	R/(W)*1	R	R	R/(W)*1	R/(W)*1

Bit	Bit Name	Initial Value	R/W	Description
b0	DR	0	R/(W) *1	Receive Data Ready Flag 0: Reception is in progress, or no received data has remained in the FRDR register after normally completed receiving. 1: Next receive data has not been received.
b1	RDF	0	R/(W) *1	Receive FIFO Data Full Flag 0: The quantity of receive data in the FRDR register falls below the specified reception trigger number. 1: The quantity of receive data written in the FRDR register is equal to or greater than the specified reception trigger number.
b2	PER	0	R	Parity Error Flag*4 0: No receive parity error occurred in the next receive data read from the FRDR register. 1: A receive parity error occurred in the next receive data read from the FRDR register.
b3	FER	0	R	Framing Error Flag*4 0: No receive framing error occurred in the next data read from the FRDR register. 1: A receive framing error occurred in the next data read from the FRDR register.
b4	BRK	0	R/(W) *1	Break Detect Flag 0: No break signal is received. 1: A break signal is received.*2
b5	TDFE	1	R/(W) *1	Transmit FIFO Data Empty Flag 0: The quantity of transmit data written in the FTDR register exceeds the specified transmission trigger number. 1: The quantity of transmit data written in the FTDR register is equal to or less than the specified transmission trigger number.*3
b6	TEND	0	R/(W) *1	Transmit End Flag 0: Transmission is in the waiting state or in progress. 1: Transmission is completed.
b7	ER	0	R/(W) *1	Receive Error Flag 0: Reception is in progress or has normally completed. 1: A framing error or parity error has occurred during reception.
b15 to b8	—	All 0	R/W	Reserved These bits are read as 0. The write value should be 0.

Note 1. 0 can be only written to clear the flag after 1 is read.

Note 2. When a break signal is detected, transfer of the receive data (H'00) to the FRDR register stops after the detection. When the break ends and the receive signal becomes mark state (high level), the transfer of receive data resumes.

Note 3. Since the FTDR register is a 16-byte FIFO register, the maximum quantity of data that can be written when TDFE is 1 is "16 minus the number of non-transmitted data units". If additional data is written, the data is ignored. The quantity of data in the FTDR register is indicated by the 8 higher-order bits of the FDR register.

Note 4. When the DMAC is used to read data, the generation of errors cannot be checked by reading this flag.

DR Bit (Receive Data Ready Flag)

Indicates that the quantity of data stored in the receive FIFO data register (FRDR) falls below the specified reception trigger number, and that no next data has been received yet after the elapse of 15 ETUs from the last stop bit in asynchronous mode. In clock synchronous mode, this bit is not set to 1.

[Setting condition]

- DR is set to 1 when the FRDR register contains less data than the specified reception trigger number, and no next data has been received yet after the elapse of 15 ETUs*¹ from the last stop bit.

[Clearing conditions]

When either of the following is satisfied:

- DR is cleared to 0 when DR = 1 is read and then 0 is written to the DR flag.
- DR is cleared to 0 when all received data in the FRDR register are read.

Note 1. This is equivalent to one and a half (1.5) frames in the 8-bit format with one stop bit (ETU: elementary time unit).

Note: When the RE bit in SCR is cleared to 0, the DR bit is not affected and retains its previous value.

RDF Bit (Receive FIFO Data Full Flag)

Indicates that receive data has been transferred to the receive FIFO data register (FRDR), and the quantity of data in FRDR becomes equal to or greater than the specified reception trigger number.

[Setting condition]

- RDF is set to 1 when the quantity of receive data which is equal to or greater than the specified reception trigger number are stored in the FRDR register*¹.

[Clearing conditions]

- RDF is cleared to 0 when RDF = 1 is read and then 0 is written to this bit.
- RDF is cleared to 0 when the FRDR register is read.

Note 1. Since the FRDR register is a 16-byte FIFO register, the maximum quantity of data that can be read when this bit is 1 is equivalent to the specified reception trigger number. If an attempt is made to read after all the data in the FRDR register has been read, the read data is undefined. The quantity of receive data in the FRDR register is indicated by the 8 lower-order bits of the FDR register.

PER Bit (Parity Error Flag)

Indicates whether there is a parity error in the data read from the receive FIFO data register (FRDR) in asynchronous mode.

[Setting condition]

- PER is set to 1 when a parity error is present in the next data read from the FRDR register.

[Clearing condition]

- PER is cleared to 0 when no parity error is present in the next data read from the FRDR register.

FER Bit (Framing Error Flag)

Indicates whether there is a framing error in the data read from the receive FIFO data register (FRDR) in asynchronous mode.

[Setting condition]

- FER is set to 1 when a framing error is present in the next data read from the FRDR register.

[Clearing condition]

- FER is cleared to 0 when no framing error is present in the next data read from the FRDR register.

BRK Bit (Break Detect Flag)

Indicates that a break signal has been detected in receive data.

[Setting condition]

- BRK is set to 1 when data including a framing error is received, and the framing error is followed by at least one frame of data received at the space 0 level (low level).

[Clearing condition]

- BRK is cleared to 0 when software reads BRK after it has been set to 1 and then writes 0 to BRK.

TDFE Bit (Transmit FIFO Data Empty Flag)

Indicates that data has been transferred from the transmit FIFO data register (FTDR) into the transmit shift register (TSR), the quantity of data in the FRDR register becomes equal to or less than the specified transmission trigger number, and writing of transmit data to the FRDR register is enabled.

[Setting conditions]

When either of the following is satisfied:

- TDFE is set to 1 when the TE bit in SCR is 0.
- TDFE is set to 1 when the quantity of transmit data written in the FRDR register is equal to or less than the specified transmission trigger number.

[Clearing conditions]

- TDFE is cleared to 0 when 0 is written in the TDFE bit after reading TDFE = 1.
- When transmit data is written to the FTDR register

TEND Bit (Transmit End Flag)

Indicates that the FRDR register contains no more valid data and transmission is completed when transmitting the last bit of the transmit data.

[Setting condition]

When the following is satisfied:

- TEND is set to 1 when the FTDR register does not contain transmit data when the last bit of the serial transmission data is transmitted.

[Clearing conditions]

- When transmit data is written to the FTDR register
- When 0 is written to TEND after it has been read as 1

ER Bit (Receive Error Flag)

Indicates the occurrence of a framing error, or of a parity error when receiving the parity-added data*1.

[Setting conditions]

When either of the following is satisfied:

- ER is set to 1 when the stop bit is found to be 0 after checking whether the stop bit of the received data is 1 at the end of one data receive operation*1.
- ER is set to 1 when the total number of 1s in the received data and parity bit combined does not match the even or odd parity setting specified by the PM bit in the SMR register.

[Clearing condition]

- When 0 is written to ER after it has been read as 1

Note 1. Clearing the RE bit to 0 in the SCR register does not affect this bit, which retains its previous value. Even if a receive error occurs, the receive data is transferred to the FRDR register and the receive operation is continued. Whether the data read from the FRDR register includes a receive error can be detected by the FER and PER bits in the FSR register.

Note: In two stop bits mode, only the first stop bit is checked; the second stop bit is not checked.

22.2.8 Bit Rate Register (BRR)

The BRR register is an 8-bit register that, together with the baud rate generator clock source selected by the CKS[1:0] bits in the serial mode register (SMR), determines the serial transmit/receive bit rate.

This register is located in the same address as that of the MDDR register and selected when the MDDRS bit in SEMR is 0. The CPU can read and write to BRR. Writing to BRR should be executed when TE = RE = 0 in the SCR register.

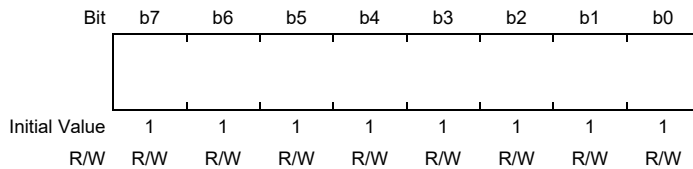

The BRR setting is calculated using the following formulae.

[Asynchronous mode]

- When the baud rate generator is in normal mode (SEMR.BGDM = 0):

$$N = \frac{P0\phi}{64 \times 2^{2n-1} \times B} \times 10^6 - 1$$

(When operating on the base clock with a frequency 16 times the bit rate (SMER.ABCS0 = 0))

$$N = \frac{P0\phi}{32 \times 2^{2n-1} \times B} \times 10^6 - 1$$

(When operating on the base clock with a frequency 8 times the bit rate (SMER.ABCS0 = 1))

- When the baud rate generator is in double-speed mode (SEMR.BGDM = 1):

$$N = \frac{P0\phi}{32 \times 2^{2n-1} \times B} \times 10^6 - 1$$

(When operating on the base clock with a frequency 16 times the bit rate (SMER.ABCS0 = 0))

$$N = \frac{P0\phi}{16 \times 2^{2n-1} \times B} \times 10^6 - 1$$

(When operating on the base clock with a frequency 8 times the bit rate (SMER.ABCS0 = 1))

[Clock synchronous mode]

$$N = \frac{P0\phi}{8 \times 2^{2n-1} \times B} \times 10^6 - 1$$

B: Bit rate (bit/s)

N: Setting of the BRR register ($0 \leq N \leq 255$) (The setting must satisfy the electrical characteristics).

P0φ: Operating frequency for peripheral modules (MHz)

n: Baud rate generator clock source (n = 0, 1, 2, 3) (For the clock sources and values of n, see **Table 22.5**).

NOTE

The MDDR register is used to adjust the bit rate. For details, see **Section 22.2.9, Modulation Duty Register (MDDR)**.

Table 22.5 SMR Register Setting

n	Clock Source	SMR Register Settings	
		CKS1	CKS0
0	P0φ	0	0
1	P0φ/4	0	1
2	P0φ/16	1	0
3	P0φ/64	1	1

The bit rate error in asynchronous mode is calculated using the following formulae.

- When the baud rate generator is in normal mode (SEMR.BGDM = 0):

$$\text{Error (\%)} = \left\{ \frac{P0\phi \times 10^6}{(N + 1) \times B \times 64 \times 2^{2n-1}} - 1 \right\} \times 100$$

(When operating on the base clock with a frequency 16 times the bit rate (SMER.ABCS0 = 0))

$$\text{Error (\%)} = \left\{ \frac{P0\phi \times 10^6}{(N + 1) \times B \times 32 \times 2^{2n-1}} - 1 \right\} \times 100$$

(When operating on the base clock with a frequency 8 times the bit rate (SMER.ABCS0 = 1))

- When the baud rate generator is in double-speed mode (SEMR.BGDM = 1):

$$\text{Error (\%)} = \left\{ \frac{P0\phi \times 10^6}{(N + 1) \times B \times 32 \times 2^{2n-1}} - 1 \right\} \times 100$$

(When operating on the base clock with a frequency 16 times the bit rate (SMER.ABCS0 = 0))

$$\text{Error (\%)} = \left\{ \frac{P0\phi \times 10^6}{(N + 1) \times B \times 16 \times 2^{2n-1}} - 1 \right\} \times 100$$

(When operating on the base clock with a frequency 8 times the bit rate (SMER.ABCS0 = 1))

Table 22.6 list the examples of the BRR register setting in asynchronous mode, and **Table 22.7** list the examples of the BRR register setting in clock synchronous mode.

Table 22.6 Bit Rates and BRR Register Settings in Asynchronous Mode

Bit Rate (bps)	P0 ϕ (MHz)		
	100		
	n	N	Error (%)
150	—	—	—
300	3	162	-0.15
600	3	80	0.47
1200	2	162	-0.15
2400	2	80	0.47
4800	1	162	-0.15
9600	1	80	0.47
14400	0	216	0.01
19200	0	162	-0.15
28800	0	108	-0.45
31250	0	99	0.00
38400	0	80	0.47
115200	0	26	0.47
500000	0	5	*1

Note: These values assume bits SEMR.ABCS0 and SEMR.BGDM are both 0.
 When either the SEMR.ABCS0 bit or SEMR.BGDM bit is set to 1, the bit rate is doubled.
 When bits SEMR.ABCS0 and SEMR.BGDM are both 1, the bit rate is quadrupled.
 Configure settings so the range of error is no greater than 1%.

Note 1. Values for the blank cells in the table can be set using the MDDR register.
 For details, see **Section 22.2.9, Modulation Duty Register (MDDR)** and the **Table 22.12**.

Table 22.7 Bit Rates and BRR Register Settings in Clock Synchronous Mode

Bit Rate (bps)	P0 ϕ (MHz)	
	100	
	n	N
250	—	—
500	—	—
1000	—	—
2500	3	155
5000	3	77
10000	3	38
25000	1	249
50000	1	124
100000	0	249
250000	0	99
500000	0	49
1000000	0	24
2500000	0	9
5000000	0	4

Note: Continuous transmission or reception is not possible.
Set the BRR register so that the range of error can fall within 1% or less.

Remarks: —: Setting is prohibited.

Table 22.8 lists the maximum bit rates for various frequencies in asynchronous mode when the baud rate generator is used. **Table 22.9** lists the maximum bit rates for various frequencies in clock synchronous mode when the baud rate generator is used. **Table 22.10** and **Table 22.11** list the maximum rates for external clock inputs in asynchronous mode and clock synchronous mode, respectively.

Table 22.8 Maximum Bit Rates for Various Frequencies with Baud Rate Generator (in Asynchronous Mode)

P0 ϕ (MHz)	Maximum Bit Rate (bit/s)	Settings	
		n	N
100	12500000	0	0

Note: These values assume bits SEMR.ABCS0 and SEMR.BGDM are both 1. When either the SEMR.ABCS0 bit or SEMR.BGDM bit is set to 1, the bit rate is 1/2. When bits SEMR.ABCS0 and SEMR.BGDM are both 1, the bit rate is 1/4.

Table 22.9 Maximum Bit Rates for Various Frequencies with Baud Rate Generator (in Clock Synchronous Mode)

P0 ϕ (MHz)	Discontinuous Transmission/Reception			Continuous Transmission/Reception		
	Maximum Bit Rate (bit/s)	Settings		Maximum Bit Rate (bit/s)	Settings	
		n	N		n	N
100	25000000	0	0	12500000	0	1

Table 22.10 Maximum Bit Rates with External Clock Input (in Asynchronous Mode)

P0 ϕ (MHz)	External Input Clock (MHz)	Maximum Bit Rate (bit/s)
100	25.00	3125000

Note: This is an example when the SEMR.ABCS0 bit is 1. When the ABCS0 bit is set to 0, the bit rate is 1/2.

Table 22.11 Maximum Bit Rates with External Clock Input (in Clock Synchronous Mode)

P0 ϕ (MHz)	External Input Clock (MHz)	Maximum Bit Rate (bit/s)
100	8.33	8330000

22.2.9 Modulation Duty Register (MDDR)

The MDDR register corrects the bit rate adjusted by the BRR register. The value after reset of this register is H'FF. When the BRME bit in SEMR is set to 1, the bit rate generated by the on-chip baud rate generator is evenly corrected according to the settings of MDDR (MDDR/256). The relationship between the MDDR register setting and the bit rate (B) is given by the following formula. The MDDR register is located in the same address as that of the BRR register and is selected when the MDDRS bit in SEMR is 1. This register is only writable when TE = RE = 0 in the SCR register. b7 in this register is fixed to 1.

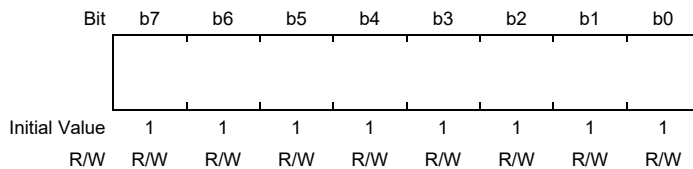

The formulae below show the relationships between the MDDR setting and the bit rate (B) when the bit rate modulation function is used.

[Asynchronous mode]

- When the baud rate generator is in normal mode (SEMR.BGDM = 0):

$$B = \frac{P0\phi \times 10^6}{64 \times 2^{2n-1} \times (256/MDDR) \times (N + 1)}$$

(When operating on the base clock with a frequency 16 times the bit rate (SEMR.ABCS0 = 0))

$$B = \frac{P0\phi \times 10^6}{32 \times 2^{2n-1} \times (256/MDDR) \times (N + 1)}$$

(When operating on the base clock with a frequency 8 times the bit rate (SEMR.ABCS0 = 1))

- When the baud rate generator is in double-speed mode (SEMR.BGDM = 1):

$$B = \frac{P0\phi \times 10^6}{32 \times 2^{2n-1} \times (256/MDDR) \times (N + 1)}$$

(When operating on the base clock with a frequency 16 times the bit rate (SEMR.ABCS0 = 0))

$$B = \frac{P0\phi \times 10^6}{16 \times 2^{2n-1} \times (256/MDDR) \times (N + 1)}$$

(When operating on the base clock with a frequency 8 times the bit rate (SEMR.ABCS0 = 1))

[Clock synchronous mode]

$$B = \frac{P0\phi \times 10^6}{8 \times 2^{2n-1} \times (256/MDDR) \times (N + 1)}$$

When the bit rate modulation is used, the bit rate average error is given by the following formulae.

- When the baud rate generator is in normal mode (SEMR.BGDM = 0):

$$\text{Error (\%)} = \left\{ \frac{P0\phi \times 10^6}{B \times 64 \times 2^{2n-1} \times (256/MDDR) \times (N + 1)} - 1 \right\} \times 100$$

(When operating on the base clock with a frequency 16 times the bit rate (SEMR.ABCS0 = 0))

$$\text{Error (\%)} = \left\{ \frac{P0\phi \times 10^6}{B \times 32 \times 2^{2n-1} \times (256/MDDR) \times (N + 1)} - 1 \right\} \times 100$$

(When operating on the base clock with a frequency 8 times the bit rate (SEMR.ABCS0 = 1))

- When the baud rate generator is in double-speed mode (SEMR.BGDM = 1):

$$\text{Error (\%)} = \left\{ \frac{P0\phi \times 10^6}{B \times 32 \times 2^{2n-1} \times (256/MDDR) \times (N + 1)} - 1 \right\} \times 100$$

(When operating on the base clock with a frequency 16 times the bit rate (SEMR.ABCS0 = 0))

$$\text{Error (\%)} = \left\{ \frac{P0\phi \times 10^6}{B \times 16 \times 2^{2n-1} \times (256/MDDR) \times (N + 1)} - 1 \right\} \times 100$$

(When operating on the base clock with a frequency 8 times the bit rate (SEMR.ABCS0 = 1))

B: Bit rate (bits/s)

N: BRR register setting ($0 \leq N \leq 255$)

The setting must satisfy the electrical characteristics).

P0φ: Operating frequency for peripheral modules (MHz)

MDDR: MDDR setting ($128 \leq MDDR \leq 256$)

n: Baud rate generator clock source (n = 0, 1, 2, 3) (For the clock sources and values of n, see **Table 22.5**).

Table 22.12 Bit Rates and BRR and MDDR Registers Settings in Asynchronous Mode

Bit Rate (bps)	P0 ϕ (MHz)			
	100			
	n	N	MDDR	Error (%)
150	3	252	199	0.02
300	3	161	255	0.08
600	3	80	255	0.08
1200	2	161	255	0.08
2400	2	80	255	0.08
4800	1	161	255	0.08
9600	1	80	255	0.08
14400	—	—	—	—
19200	0	161	255	0.08
28800	0	107	254	0.08
31250	—	—	—	—
38400	0	80	253	0.08
115200	0	26	255	0.08
500000	0	5	246	0.10

Note: These values assume bits SEMR.ABCS0 and SEMR.BGDM are both 0. When either the SEMR.ABCS0 bit or SEMR.BGDM bit is set to 1, the bit rate is doubled. When bits SEMR.ABCS0 and SEMR.BGDM are both 1, the bit rate is quadrupled. Configure settings so the range of error is no greater than 1%.

22.2.10 FIFO Control Register (FCR)

The FCR register resets the quantity of data in the transmit FIFO data register (FTDR) and the receive FIFO data register (FRDR) and specifies the number of triggers. This register also specifies whether to enable the loop-back test.

The CPU can always read and write to the FCR register.

Bit	b15	b14	b13	b12	b11	b10	b9	b8	b7	b6	b5	b4	b3	b2	b1	b0
	—	—	—	—	—	RSTRG[2:0]			RTRG[1:0]		TTRG[1:0]		MCE	TFRST	RFRST	LOOP
Initial Value	0	0	0	0	0	0	0	0	0	0	0	0	0	0	0	0
	R/W	R/W	R/W	R/W	R/W	R/W	R/W	R/W	R/W	R/W	R/W	R/W	R/W	R/W	R/W	R/W

Bit	Bit Name	Initial Value	R/W	Description
b0	LOOP	0	R/W	Loop-Back Test 0: Loop back test is disabled. 1: Loop back test is enabled
b1	RFRST	0	R/W	Receive FIFO Data Register Reset 0: Normal operation 1: Resets the FRDR register.
b2	TFRST	0	R/W	Transmit FIFO Data Register Reset 0: Normal operation 1: Resets the FTDR register.
b3	MCE	0	R/W	Modem Control Enable 0: Model signal is disabled.*1 1: Model signal is enabled.
b5, b4	TTRG[1:0]	All 0	R/W	Transmit FIFO Data Trigger Number Select b5 b4 0 0: 8 (8)*2 0 1: 4 (12)*2 1 0: 2 (14)*2 1 1: 0 (16)*2
b7, b6	RTRG[1:0]	All 0	R/W	Receive FIFO Data Trigger Number Select In asynchronous mode: b7 b6 0 0: 1 0 1: 4 1 0: 8 1 1: 14 In clock synchronous mode: b7 b6 0 0: 1 0 1: 2 1 0: 8 1 1: 14
b10 to b8	RSTRG[2:0]	All 0	R/W	RTS# Output Active Trigger Number Select b10 b8 0 0 0: 15 0 0 1: 1 0 1 0: 4 0 1 1: 6 1 0 0: 8 1 0 1: 10 1 1 0: 12 1 1 1: 14

Bit	Bit Name	Initial Value	R/W	Description
b15 to b11	—	All 0	R/W	Reserved These bits are read as 0. The write value should be 0.

Note 1. The CTS# input level does not affect the transmit operation. Similarly, the RTS# input level does not affect the receive operation.

Note 2. Values in parentheses mean the number of empty bytes in the FTDR register when the TDFE flag is set to 1 and a transmit FIFO data empty interrupt (TXI) request is generated.

LOOP Bit (Loop-Back Test)

Internally connects between the transmit output pin (TXD) and the receive input pin (RXD) and between the RTS# pin and the CTS# pin, to perform loop-back testing.

RFRST Bit (Receive FIFO Data Register Reset)

Disables the receive data in the receive FIFO data register (FRDR) and makes the data to the empty state. If you set this bit to 1, be sure to clear it to 0 afterward.

TFRST Bit (Transmit FIFO Data Register Reset)

Disables the transmit data in the transmit FIFO data register (FTDR) and makes the data to the empty state. If you set this bit to 1, be sure to clear it to 0 afterward.

MCE Bit (Modem Control Enable)

Specifies whether to enable or disable the modem control signals, CTS# and RTS#. In clock synchronous mode, this bit should always be set to 0.

TTRG[1:0] Bits (Transmit FIFO Data Trigger Number Select)

Specify the reference quantity of data for transmission (i.e., the threshold number of entries to trigger the writing of further data for transmission) for setting of the TDFE flag in the serial status register (FSR). When the number of entries for transmission in the transmission FIFO, i.e. the number of entries written to the transmit FIFO data register (FTDR) that are yet to be transmitted, falls to or below the specified trigger number for transmission, the TDFE flag is set to 1 and a transmit FIFO data empty interrupt (TXI) request is generated.

The setting in these bits is valid when the TTRGS bit in the FTDR register is 0. When the TTRGS bit in the FTDR register is 1, the setting of the TTRG[4:0] bits in the FTDR register is valid.

RTRG[1:0] Bits (Receive FIFO Data Trigger Number Select)

Specify the reference quantity of receive data (i.e., the threshold number of entries to trigger the reading of received data) for setting of the RDF flag in the serial status register (FSR). When the number of entries in the reception FIFO, i.e. the number of entries yet to be read from the receive FIFO data register (FRDR), rises to or above the specified trigger number for reception, the RDF flag is set to 1 and a receive FIFO data full interrupt (RXI) request is generated.

The setting in these bits is valid when the RTRGS bit in the FTDR register is 0. When the RTRGS bit in the FTDR register is 1, the setting of the RTRG[4:0] bits in the FTDR register is valid.

RSTRG[2:0] Bits (RTS# Output Active Trigger Number Select)

When the number of entries in the reception FIFO, i.e. the number of entries yet to be read from the receive FIFO data register (FRDR), rises to or above the specified trigger number, the RTS# signal is in the high state.

The setting in these bits is only valid when a modem signal is enabled by the MCE bit in this register in asynchronous mode.

22.2.11 FIFO Data Count Register (FDR)

The FDR register indicates the quantity of data stored in the transmit FIFO data register (FTDR) and the receive FIFO data register (FRDR).

This register indicates the quantity of transmit data in the FTDR register with the 8 higher-order bits, and the quantity of receive data in the FRDR register with the 8 lower-order bits. The CPU can always read the FDR register.

Bit	b15	b14	b13	b12	b11	b10	b9	b8	b7	b6	b5	b4	b3	b2	b1	b0
	—	—	—	T[4:0]				—	—	—	R[4:0]					
Initial Value	0	0	0	0	0	0	0	0	0	0	0	0	0	0	0	0
R/W	R	R	R	R	R	R	R	R	R	R	R	R	R	R	R	R

Bit	Bit Name	Initial Value	R/W	Description
b4 to b0	R[4:0]	All 0	R	Receive Data Quantity in FRDR Indicate the quantity of receive data stored in the FRDR register.
b7 to b5	—	All 0	R	Reserved These bits are read as 0.
b12 to b8	T[4:0]	All 0	R	Non-Transmitted Data Quantity in FTDR Indicate the quantity of non-transmitted data stored in the FTDR register.
b15 to b13	—	All 0	R	Reserved These bits are read as 0.

R[4:0] Bits

Indicate the quantity of receive data stored in the FRDR register.

H'00 means no received data, and H'10 means that all of the received data is stored in the FRDR register.

T[4:0] Bits

Indicate the quantity of non-transmitted data stored in the FTDR register.

H'00 means no transmit data, and H'10 means that all of the data for transmission is stored in the FTDR register.

22.2.12 Serial Port Register (SPTR)

The SPTR register controls input/output and data of the pins multiplexed to SCIFA function. The CPU can always read and write to the SPTR register.

NOTE

b6, b4, b2, and b0 of this register respectively indicate the input status of their corresponding pins. See the descriptions for each bit for details. Writings to these bits in 1-bit unit are handled as read-modify-write, which may lead to undesired values to be written. To avoid this, when modifying the SPB2DT or SPB2IO bit, for example, write the other bit (the bit used in combination) at the same time.

Bit	b15	b14	b13	b12	b11	b10	b9	b8	b7	b6	b5	b4	b3	b2	b1	b0
	—	—	—	—	—	—	—	—	RTS2IO	RTS2DT	CTS2IO	CTS2DT	SCKIO	SCKDT	SPB2IO	SPB2DT
Initial Value	0	0	0	0	0	0	0	0	0	x	0	x	0	x	0	x
R/W	R/W	R/W	R/W	R/W	R/W	R/W	R/W	R/W	R/W	R/W	R/W	R/W	R/W	R/W	R/W	R/W

Remarks: x: Undefined

Bit	Bit Name	Initial Value	R/W	Description
b0	SPB2DT	x	R/W	Serial Port Break Data Select Controls the TXD pin in combination with the TE bit in the SCR register and the SPB2IO bit. See Table 22.15 .
b1	SPB2IO	0	R/W	Serial Port Break Input/Output Controls the TXD pin in combination with the TE bit in the SCR register and the SPB2DT bit.
b2	SCKDT	x	R/W	SCK Port Data Select Controls the SCK pin in combination with the CM bit in the SMR register, the SCKIO bit, and the CKE1 and CKE0 bits in the SCR register. See Table 22.17 .
b3	SCKIO	0	R/W	SCK Port Input/Output Controls the SCK pin in combination with the CM bit in the SMR register, the SCKDT bit, and the CKE1 and CKE0 bits in the SCR register. See Table 22.17 .
b4	CTS2DT	x	R/W	CTS# Port Data Select Controls the CTS# pin in combination with MCE bit in FCR and CTS2IO bit. See Table 22.14 . The SCIF 3 and SCIF 4 channels are not supported.
b5	CTS2IO	0	R/W	CTS# Port Output Specify Controls the CTS# pin in combination with MCE bit in FCR and CTS2IO bit. See Table 22.14 . The SCIF 3 and SCIF 4 channels are not supported.
b6	RTS2DT	x	R/W	RTS# Port Data Select Controls the RTS# pin in combination with MCE bit in FCR and RTS2IO bit. See Table 22.13 . The SCIF 3 and SCIF 4 channels are not supported.
b7	RTS2IO	0	R/W	RTS# Port Output Specify Controls the RTS# pin in combination with MCE bit in FCR and RTS2IO bit. See Table 22.13 . The SCIF 3 and SCIF 4 channels are not supported.
b15 to b8	—	All 0	R/W	Reserved These bits are read as 0. The write value should be 0.

Remarks: x: Undefined

SPB2DT Bit (Serial Port Break Data Select)

This bit specifies the output level of the TXD pin when the setting of the SCR.TE bit is 0. The RXD pin input status can be read from this bit regardless of the SPB2IO bit setting. However, the RXD pin function must have been selected with the general I/O port.

SPB2IO Bit (Serial Port Break Input/Output)

Controls the TXD pin in combination with the TE bit in the SCR register and the SPB2DT bit.

SCKDT Bit (SCK Port Data Select)

The SCK pin status can be read from this bit regardless of the SCKIO bit setting. (When the SCK pin is used for input, the input signal is invalid (has no means) but the pin status can be read.) However, the SCK pin function must have been selected with the general I/O port.

SCKIO Bit (SCK Port Input/Output)

Specifies input or output status of the SCK pin. This bit controls the SCK pin in combination with the SCKDT bit, the CM bit in the SMR register, and the CKE1 and CKE0 bits in the SCR register.

CTS2DT Bit (CTS# Port Data Select)

The status of the CTS# pin can be read from this bit regardless of the CTS2IO bit setting. However, the CTS# pin function must have been selected with the general I/O port.

RTS2DT Bit (RTS# Port Data Select)

The status of the RTS# pin can be read from this bit regardless of the RTS2IO bit setting. However, the RTS# pin function must have been selected with the general I/O port.

Table 22.13 RTS# Pin Status

FCR.MCE Bit Setting	RTS2IO Bit Setting	RTS2DT Bit Setting	RTS# Pin Status
0	0	×	Setting prohibited* ¹
0	1	0	Low output
0	1	1	High output
1	×	×	Modem control output

Remarks: ×: Don't care

Note 1. There is no problem with the initial setting if the RTS# pin is not used.

Table 22.14 CTS# Pin Status

FCR.MCE Bit Setting	CTS2IO Bit Setting	CTS2DT Bit Setting	CTS# Pin Status
0	0	×	Setting prohibited* ¹
0	1	0	Low output
0	1	1	High output
1	×	×	Modem control input

Remarks: ×: Don't care

Note 1. There is no problem with the initial setting if the CTS# pin is not used.

Table 22.15 TXD Pin Status

SCR.TE Bit Setting	SPB2IO Bit Setting	SPB2DT Bit Setting	TXD Pin Status
0	0	×	Setting prohibited
0	1	0	Low output
0	1	1	High output
1	×	×	Transmit data output

Remarks: ×: Don't care

22.2.13 Line Status Register (LSR)

The LSR register is a 16-bit register. The PER and FER bits indicate the number of receive errors in the receive FIFO data register. 1 cannot be written to the OREER status flag. The flag should be read as 1 prior to clearing it to 0.

Bit	b15	b14	b13	b12	b11	b10	b9	b8	b7	b6	b5	b4	b3	b2	b1	b0
	—	—	—	—	PER[3:0]				—	—	FER[3:0]				—	ORER
Initial Value	0	0	0	0	0	0	0	0	0	0	0	0	0	0	0	0
R/W	R	R	R	R	R	R	R	R	R	R	R	R	R	R	R	R(W)*1

Bit	Bit Name	Initial Value	R/W	Description
b0	ORER	0	R/(W) *1	Overrun Error Flag 0: Reception is in progress or has normally completed. 1: An overrun error has occurred during reception.
b1	—	0	R	Reserved This bit is read as 0.
b5 to b2	FER[3:0]	All 0	R	Framing Error Count Indicates the quantity of data with a framing error among the receive data stored in the receive FIFO data register (FRDR).
b7, b6	—	All 0	R	Reserved These bits are read as 0.
b11 to b8	PER[3:0]	All 0	R	Parity Error Count Indicates the quantity of data with a parity error among the receive data stored in the receive FIFO data register (FRDR).
b15 to b12	—	All 0	R	Reserved These bits are read as 0.

Note 1. To clear the flag, 0 can be only written after 1 is read.

ORER Bit (Overrun Error Flag)

Indicates that receive operation abnormally stops due to occurrence of an overrun error. This flag is not affected and retains its previous state if the RE bit in the serial control register (SCR) is cleared to 0. The receive FIFO data register (FRDR) retains the data before an overrun error occurred, and newly received data is lost. When the ORER bit is set to 1, the SCIFA cannot continue subsequent serial reception.

[Setting condition]

- When the next serial reception is completed with the receive FIFO in full state (16-byte data is received)

[Clearing condition]

- When 0 is written to ORER after being read as 1.

Note: When the internal clock is selected while the SCIFA is in clock synchronous mode, the amount of receive data can be controlled, so no overrun occurs.

FER[3:0] Bits (Framing Error Count)

The values of bits 5 to 2 indicate the quantity of data with a framing error after the ER bit in the FSR register is set. Reading 0000 from the FER[3:0] bits means all 16-byte receive data in the FRDR register have a framing error.

PER[3:0] Bits (Parity Error Count)

The values of bits 11 to 8 indicate the quantity of data with a parity error after the ER bit in the FSR register is set. Reading 0000 from the PER[3:0] bits means all 16-byte receive data in the FRDR register have a parity error.

22.2.14 Serial Extended Mode Register (SEMR)

The SEMR register specifies either LSB or MSB first, enables the noise cancellation, operation in normal or double-speed mode of the baud rate generator, and bit rate modulation, and selects the modulation register and the sampling count (either 8 or 16 times).

Bit	b7	b6	b5	b4	b3	b2	b1	b0
	BGDM	—	BRME	MDDRS	DIR	NFEN	—	ABCS0
Initial Value	0	0	0	0	0	0	0	0
R/W	R/W	R/W	R/W	R/W	R/W	R/W	R/W	R/W

Bit	Bit Name	Initial Value	R/W	Description
b0	ABCS0	0	R/W	Asynchronous Base Clock Select 0: Operates on a frequency 16 times the transfer rate as the base clock. 1: Operates on a frequency 8 times the transfer rate as the base clock.
b1	—	0	R/W	Reserved This bit is read as 0. The write value should be 0.
b2	NFEN	0	R/W	Noise Cancellation Enable 0: Noise cancellation for the RxD pin is disabled. 1: Noise cancellation for the RxD pin is enabled.
b3	DIR	0	R/W	Data Transfer Direction Select 0: Transmits the data in the FTDR register by the LSB-first method. The received data is stored in the FRDR register by the LSB- first method. 1: Transmits the data in the FTDR register by the MSB-first method. The received data is stored in the FRDR register by the MSB- first method.
b4	MDDRS	0	R/W	Modulation Duty Register Select 0: BRR register is accessible. 1: MDDR register is accessible.
b5	BRME	0	R/W	Bit Rate Modulation Enable 0: Bit rate modulation is disabled. 1: Bit rate modulation is enabled.
b6	—	0	R/W	Reserved This bit is read as 0. The write value should be 0.
b7	BGDM	0	R/W	Baud Rate Generator Double- Speed Mode Select 0: Baud rate generator normal mode: Baud rate generator operates on the clock signal produced by dividing the clock source by two. 1: Baud rate generator double-speed mode: Baud rate generator operates on the clock signal produced by the clock source (no frequency division).

ABCS0 Bit (Asynchronous Base Clock Select)

Selects the base clock for 1-bit period in asynchronous mode.

This bit setting is valid only in asynchronous mode (i.e., when the CM bit in the SMR register is 0).

NFEN Bit (Noise Cancellation Enable)

Reduces noise of the input to the RxD pin. This function is only valid in asynchronous mode. For details, see **Section 22.7, Noise Cancellation**.

In clock synchronous mode, this bit should always be set to 0.

DIR Bit (Data Transfer Direction Select)

Selects the serial communication format. This bit is valid only when the transmit/receive data is in 8-bit formats.*1

Note 1. Asynchronous mode or clock synchronous mode with the 8-bit data length

MDDRS Bit (Modulation Duty Register Select)

Selects the register to be enabled access to it.

BRME Bit (Bit Rate Modulation Enable)

Specifies whether to enable or disable the bit rate modulation.

BGDM Bit (Baud Rate Generator Double-Speed Mode Select)

Selects operating mode of the baud rate generator. When setting 1 in this bit, the baud rate generator included in the SCIFA operates in double-speed mode. The setting of this bit is only effective in asynchronous mode (SMR.CM bit = 0) when the internal clock is selected as the clock source (SCR.CKE[1:0] = 00b). Use normal mode under any other settings.

22.2.15 FIFO Trigger Control Register (FTCR)

The FTCCR register is a 16-bit register that specifies FIFO trigger conditions. The CPU can always read from and write to the FTCCR register.

Bit	b15	b14	b13	b12	b11	b10	b9	b8	b7	b6	b5	b4	b3	b2	b1	b0
	RTRGS	—	—	RFTC[4:0]				TTRGS	—	—	TFTC[4:0]					
Initial Value	0	0	0	1	1	1	1	1	0	0	0	1	1	1	1	1
R/W	R/W	R/W	R/W	R/W	R/W	R/W	R/W	R/W	R/W	R/W	R/W	R/W	R/W	R/W	R/W	R/W

Bit	Bit Name	Initial Value	R/W	Description
b4 to b0	TFTC[4:0]	All 1	R/W	Transmit FIFO Data Trigger Number H'00: Transmit data trigger number is 0. H'0F: Transmit data trigger number is 15. Do not set H'10 to H'1F in these bits.
b6, b5	—	All 0	R/W	Reserved These bits are read as 0. The write value should be 0.
b7	TTRGS	0	R/W	Transmit Trigger Select 0: TTRG[1:0] bits in FCR are valid. 1: TFTC[4:0] bits in FTCCR are valid.
b12 to b8	RFTC[4:0]	All 1	R/W	Receive FIFO Data Trigger Number H'01: Receive data trigger number is 1. H'10: Receive data trigger number is 16. Do not set H'00 and H'11 to H'1F in these bits.
b14, b13	—	All 0	R/W	Reserved These bits are read as 0. The write value should be 0.
b15	RTRGS	0	R/W	Receive Trigger Select 0: RTRG[1:0] bits in FCR are valid. 1: RFTC[4:0] bits in FTCCR are valid.

TFTC[4:0] Bits (Transmit FIFO Data Trigger Number)

Specify the reference quantity of data for transmission (i.e., the threshold number of entries to trigger the writing of further data for transmission) for setting of the TDFE flag in the serial status register (FSR).

When the number of entries for transmission in the transmission FIFO, i.e. the number of entries written to the transmit FIFO data register (FTDR) that are yet to be transmitted, falls to or below the specified trigger number for transmission, the TDFE flag is set to 1 and a transmit FIFO data empty interrupt (TXI) request is generated.

RFTC[4:0] Bits (Receive FIFO Data Trigger Number)

Specify the reference quantity of receive data (i.e., the threshold number of entries to trigger the reading of received data) for setting of the RDF flag in the serial status register (FSR).

When the number of entries in the reception FIFO, i.e. the number of entries yet to be read from the receive FIFO data register (FRDR), rises to or above the specified trigger number for reception, the RDF flag is set to 1 and a receive FIFO data full interrupt (RXI) request is generated.

22.3 Operation

22.3.1 Overview

For serial communication, the SCIFA can select either asynchronous mode in which characters are synchronized individually or a clock synchronous mode in which communication is synchronized with clock pulses.

The SCIFA has a 16-stage FIFO buffer for both transmission and receptions, reducing the overhead of the CPU and enabling continuous high-speed communication. The RTS# and CTS# signals are provided as modem control signals. Selection of a transmission/reception format is enabled with the serial mode register (SMR). **Table 22.16** shows the transmission format which can be selected in the serial mode register (SMR). As shown in **Table 22.17**, the SCIFA clock source can be selected by the combination of the CKE1 and CKE0 bits in the serial control register (SCR).

(1) Asynchronous Mode

- Data length is selectable either 7 or 8 bits
- Parity addition and 1- or 2-bit stop bit addition are selectable.
(The combination of the preceding selections determines the transmission/reception format and character length).
- In reception, it is possible to detect framing errors, parity errors, receive FIFO data full, overrun errors, receive data ready, and breaks.
- The stored data quantities are indicated in the FIFO data count register (FDR), respectively for transmit and receive FIFO data.
- An internal or external clock can be selected as the SCIFA clock source.
When an internal clock is selected, the SCIFA operates using the clock of on-chip baud rate generator and can output the clock with a frequency 16 (or 8) times the bit rate.
When an external clock is selected, the external clock input must have a frequency 16 (or 8) times the bit rate. (The on-chip baud rate generator is not used.)

(2) Clock Synchronous Mode

- The transmission/reception format is fixed to the 8-bit data length.
- In reception, it is possible to detect overrun errors (ORER).
- An internal or external clock can be selected as the SCIFA clock source.
When an internal clock is selected, the SCIFA operates using the clock of the on-chip baud rate generator, and outputs this clock to external devices as the synchronous clock.
When an external clock is selected, the SCIFA operates on the input synchronous clock not using the on-chip baud rate generator.

Table 22.16 SMR Register Settings and SCIFA Communication Formats

SMR Register				Mode	SCIFA Transmission/Reception Format		
b7	b6	b5	b3		Data Length	Parity Bit	Stop Bit Length
CM	CHR	PE	STOP				
0	0	0	0	Asynchronous mode	8 bits	Not set	1 bit
			1				2 bits
		1	0			Set	1 bit
			1			2 bits	
	1	0	0		7 bits	Not set	1 bit
			1				2 bits
		1	0			Set	1 bit
			1			2 bits	
1	x	x	x	Clock synchronous mode	8 bits	Not set	None

Remarks: x: Don't care

Table 22.17 SMR, SCR, and SPTR Register Settings and SCIFA Clock Source Selection

SMR Register	SCR Register		SPTR Register		Mode	Clock Source	SCK Pin Function		
	b7	b1	b0	b3				b2	
CM	CKE1	CKE0	SCKIO	SCKDT					
0	0	0	0	x	Asynchronous mode	Internal	Input pin (input signal invalid) (Initial state)		
			1	0			SCK pin state: Low		
			1	1			SCK pin state: High		
		1	x	x			Outputs a clock with frequency 16/8 times the bit rate*1		
			0	x			x	External	Inputs a clock with frequency 16/8 times the bit rate*2
				1			x		
1	0	x	x	Clock synchronous mode	Internal	Outputs the synchronous clock			
		1	0			x	External	Inputs the synchronous clock	
			1			x	Setting prohibited		

Remarks: x: Don't care

Note 1. SEMR.ABCS0 = 0: Output a clock that has a frequency 16 times the bit rate. SEMR.ABCS0 = 1: Output a clock that has a frequency 8 times the bit rate.

Note 2. SEMR.ABCS0 = 0: Input a clock that has a frequency 16 times the bit rate. SEMR.ABCS0 = 1: Input a clock that has a frequency 8 times the bit rate.

22.3.2 Operation in Asynchronous Mode

In asynchronous mode, each transmitted or received character begins with a start bit and ends with a stop bit. Serial communication is synchronized one character at a time.

The transmitting and receiving sections of the SCIFA are independent, so full duplex communication is possible. The transmitter and receiver are 16-stage FIFO buffered, so data can be written and read while transmitting and receiving are in progress, enabling continuous transmission and reception.

Figure 22.2 shows the general format of asynchronous serial communication.

In asynchronous serial communication, the communication line is normally held in the mark (high) state. The SCIFA monitors the line and starts serial communication when the line goes to the space (low) state, considered as a start bit. One serial character consists of a start bit (low), data (LSB first when LSB-first transfer is selected), parity bit (high or low), and stop bit (high), in that order.

When receiving in asynchronous mode, the SCIFA synchronizes at the falling edge of the start bit. The SCIFA samples each data bit on the eighth pulse of a clock with a frequency 16 or 8 times the bit rate*¹. Receive data is latched at the center of each bit.

- Note 1.** When the SEMR.ABCS0 bit = 0, data is sampled on the eighth pulse of a clock with a frequency 16 times the bit rate.
When the SEMR.ABCS0 bit = 1, data is sampled on the fourth pulse of a clock with a frequency 8 times the bit rate.

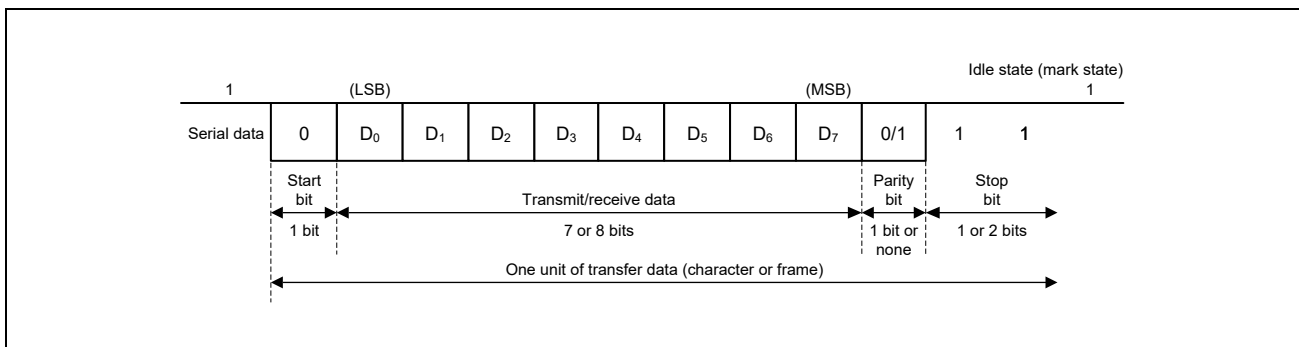

Figure 22.2 Data Format in Asynchronous Communication
(8-Bit Data with Parity and Two Stop Bits when LSB-First Transfer is Selected)

(1) Transmit/Receive Formats

Table 22.18 lists the eight communications formats that can be selected in asynchronous mode. The format is selected by setting in the serial mode register (SMR).

Table 22.18 Serial Communications Formats (in Asynchronous Mode)

SMR Setting			Serial Transmit/Receive Format and Frame Length												
CHR	PE	STOP	1	2	3	4	5	6	7	8	9	10	11	12	
0	0	0	START	8-bit data							STOP				
		1	START	8-bit data							STOP	STOP			
	1	0	START	8-bit data							P	STOP			
		1	START	8-bit data							P	STOP	STOP		
1	0	0	START	7-bit data						STOP					
		1	START	7-bit data						STOP	STOP				
	1	0	START	7-bit data						P	STOP				
		1	START	7-bit data						P	STOP	STOP			

Note: START: Start bit
 STOP: Stop bit
 P: Parity bit

(2) Clock

An SCIFA transmit/receive clock can be selected from two types of clock sources: the internal clock generated by the on-chip baud rate generator, the external clock input from the SCK pin. The clock source is selected by the settings of the CM bit in the serial mode register (SMR), the CKE[1:0] bits in the serial control register (SCR), and the ACS0 bit in the serial extended mode register (SEMR). For clock source selection, refer to **Table 22.17**.

When an external clock is input at the SCK pin, it must have a frequency equal to 16/8 times the desired bit rate.

When the SCIFA operates on an internal clock, it can output a clock signal on the SCK pin. The frequency of this output clock is 16/8 times the desired bit rate.

(3) Transmitting and Receiving Data

SCIFA Initialization (in Asynchronous Mode)

Before transmitting or receiving data, clear the TE and RE bits to 0 in the serial control register (SCR), and then initialize the SCIFA as follows.

When changing operating mode or communication format, always clear the TE and RE bits in the SCR register to 0 before following the procedure given below. Clearing TE to 0 initializes the transmit shift register (TSR). Clearing TE and RE to 0, however, does not initialize the serial status register (FSR), transmit FIFO data register (FTDR), or receive FIFO data register (FRDR), which retain their previous contents. Clear TE to 0 after all transmit data has been transmitted and the TEND flag in the FSR register is set. The TE bit can be cleared to 0 during transmission, but the transmit data (the TXD pin output level) after the TE bit is cleared to 0 depends on the settings of the SPB2IO and SPB2DT bits in the SPTR register. Set the TFRST bit in the FCR register to 1 and reset the FTDR register before TE is set to 1 again to start transmission.

When an external clock is used, the clock should not be stopped during initialization or subsequent operation. SCIFA operation becomes unreliable if the clock is stopped. **Figure 22.3** shows a sample flowchart for initializing the SCIFA in asynchronous mode.

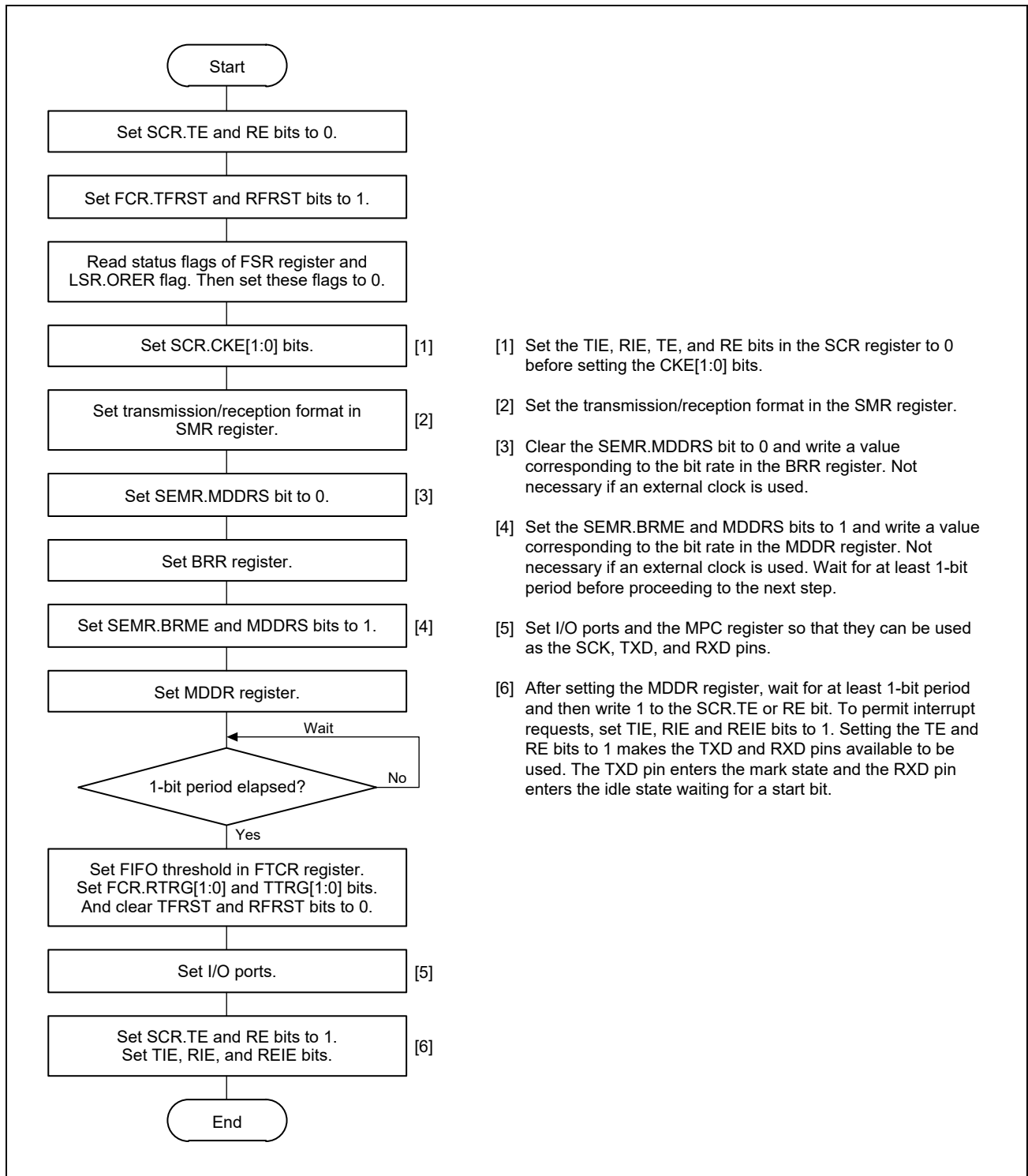

Figure 22.3 Sample Flowchart for SCIFA Initialization in Asynchronous Mode

Transmitting Serial Data (in Asynchronous Mode)

Figure 22.4 shows a sample flowchart for serial transmission in asynchronous mode.

Follow the procedure given below for serial data transmission after enabling the SCIFA for transmission.

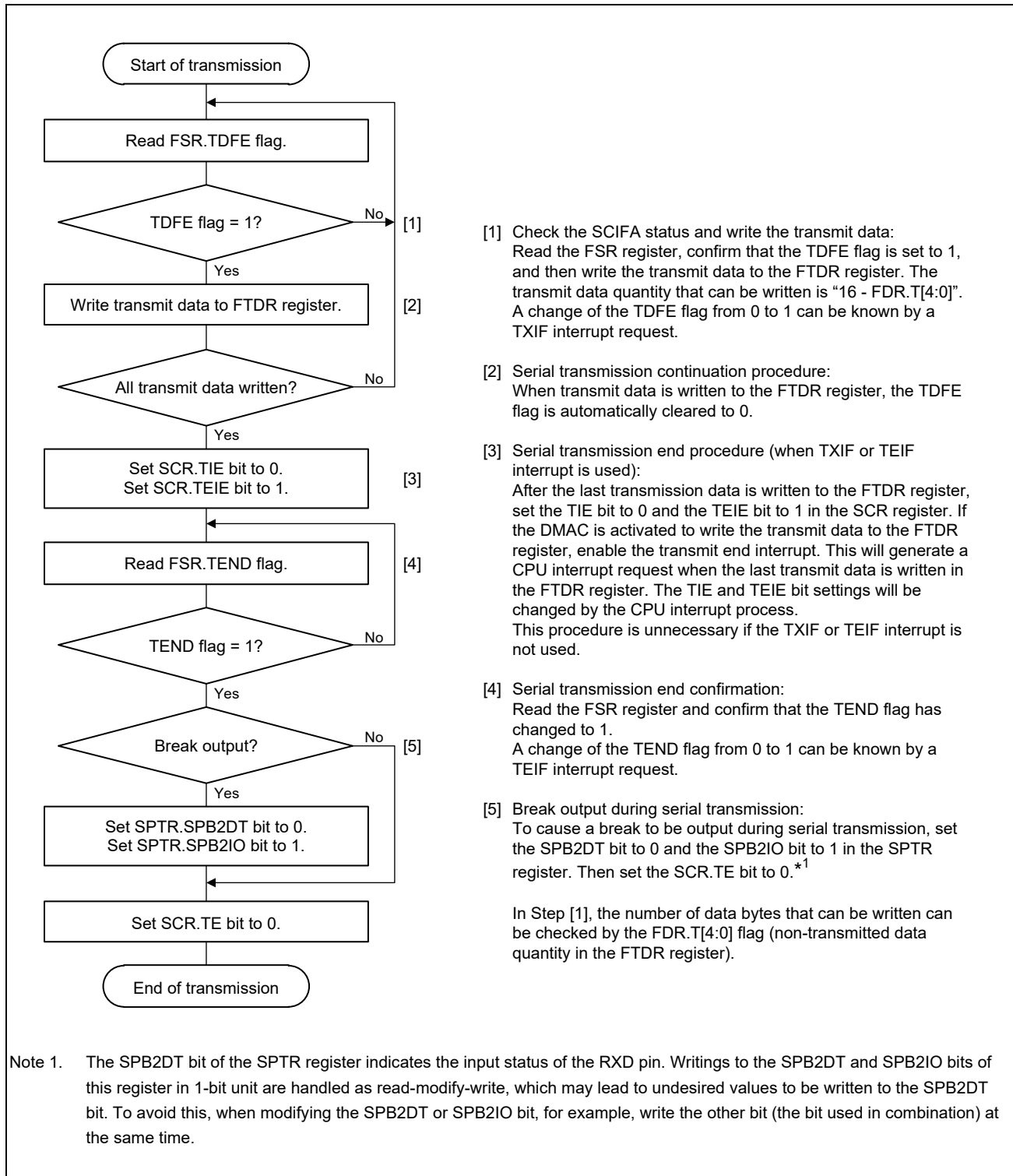

Figure 22.4 Sample Flowchart for Transmitting Serial Data in Asynchronous Mode

In asynchronous mode, the SCIFA performs serial transmission as described below.

1. When data is written into the transmit FIFO data register (FTDR) by the TXI interrupt processing routine, the SCIFA transfers the data from the FTDR register to the transmit shift register (TSR) and starts transmission. Confirm that the TDFE flag in the serial status register (FSR) is set to 1 before writing transmit data to the FTDR register. The number of data bytes that can be written is “16 minus the number of non-transmitted data units”.
2. When data is transferred from the FTDR register to the TSR register and transmission is started, consecutive transmit operations are performed until there is no transmit data left in the FTDR register. When the number of transmit data bytes in the FTDR register becomes equal to or less than the transmission trigger number specified in the FIFO control register (FCR) or FIFO trigger control register (FTCR), the TDFE flag is set. If the TIE bit in the serial control register (SR) is set to 1 at this time, a transmit-FIFO-data-empty interrupt (TXI) request is generated. The serial transmit data is output from the TXD pin in the following order.
 - a) Start bit: One-bit 0 is output.
 - b) Transmit data: 8- or 7-bit data is output in LSB-first order (when LSB-first transfer is selected).
 - c) Parity bit: One parity bit (even or odd parity) is output. (A format in which a parity bit is not output can also be selected.)
 - d) Stop bit(s): One or two 1 bits (stop bits) are output.
 - e) Mark state: 1 is output continuously until the start bit that starts the next transmission is output.
3. The SCIFA checks the transmit data of the FTDR register at the timing for sending the stop bit. If data is present, the data is transferred from the FTDR register to the TSR register, the stop bit is output, and then serial transmission of the next frame is started. If there is no data to be transmitted, the TEND flag in the FSR register is set to 1, the stop bit is output, and then the SCIFA enters the mark state (high level) in which 1 is output continuously.

Figure 22.5 shows an example of the operation for transmission in asynchronous mode.

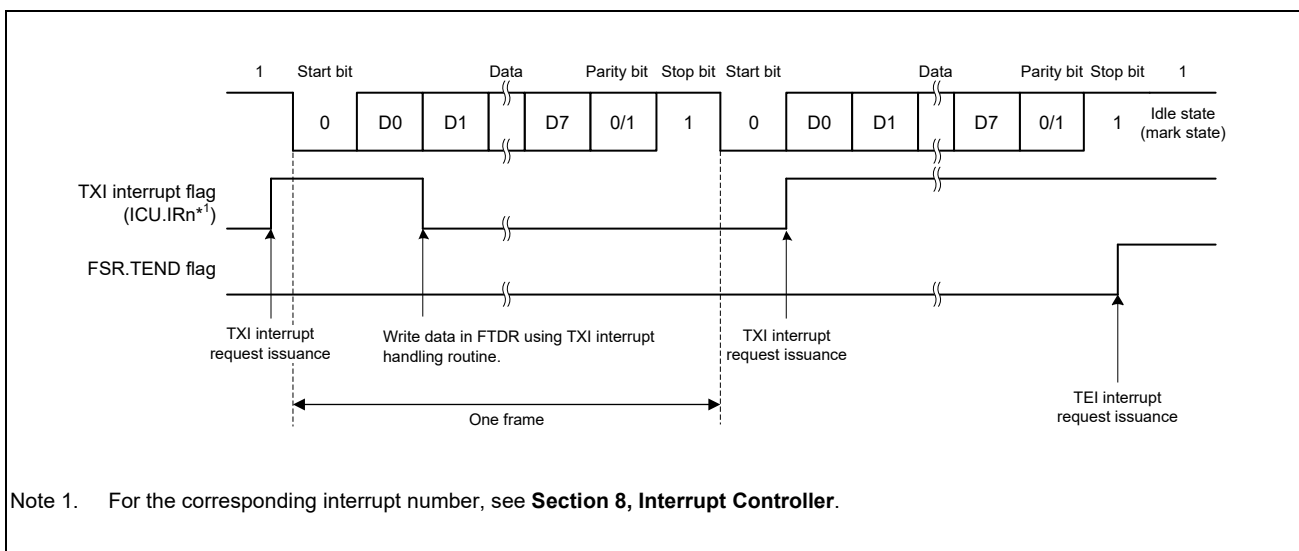

Figure 22.5 Example of Transmit Operation in Asynchronous Mode
(8-Bit Data with Parity and One Stop Bit when LSB-First Transfer is Selected)

4. When modem control is enabled, transmission can be stopped/resumed by the input level to the CTS# pin. When a high level is input to the CTS# pin during transmission, the SCIFA enters the mark state (high level) after completion of one-frame data transmission. When a low level is input to the CTS# pin, output of the next data to be transmitted begins with a start bit. **Figure 22.6** shows an example of the operation for transmission when using the modem control function.

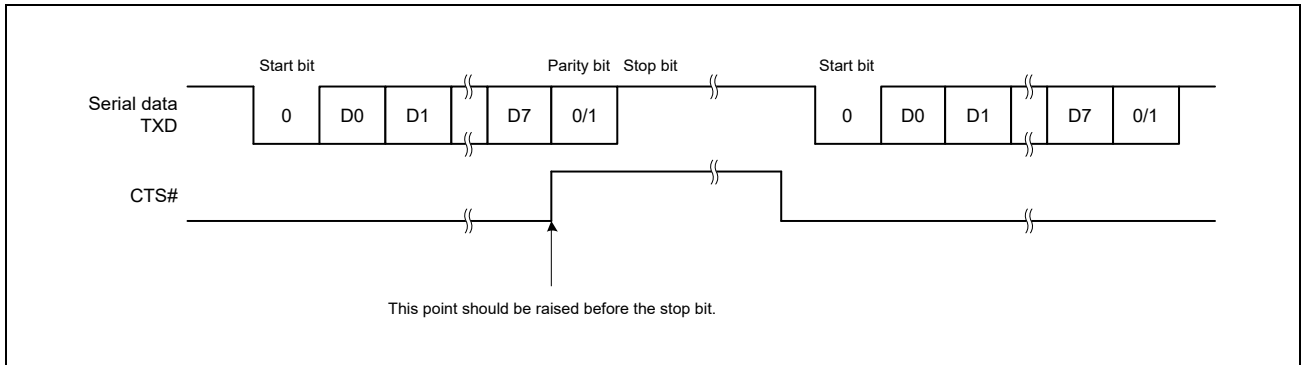

Figure 22.6 Example of Transmit Operation in Asynchronous Mode Using Modem Control Function (CTS#)

Receiving Serial Data (in Asynchronous Mode)

Figure 22.7 and Figure 22.8 show sample flowcharts for serial reception in asynchronous mode. Follow the procedure given below for serial data reception after enabling the SCIFA for reception.

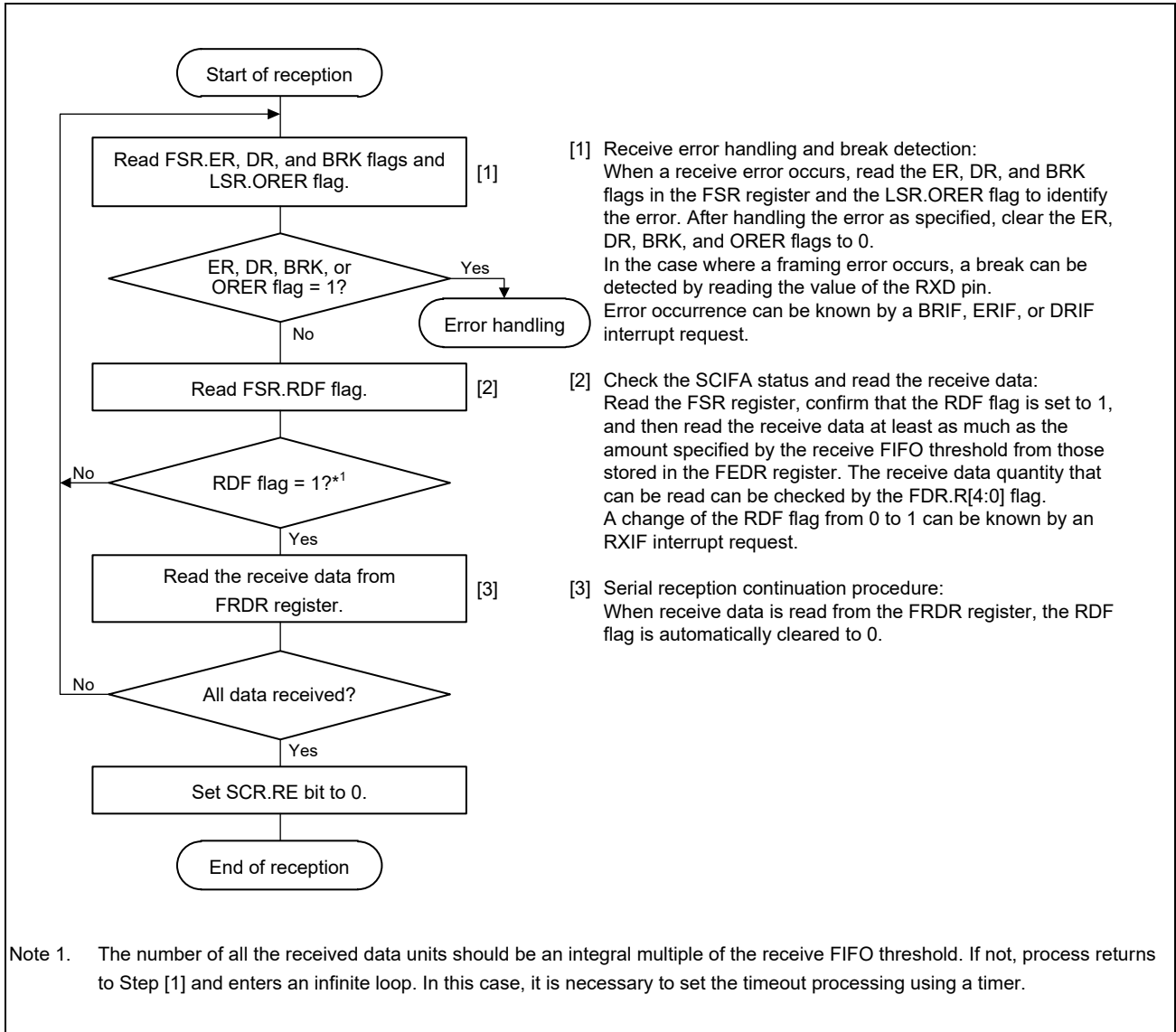
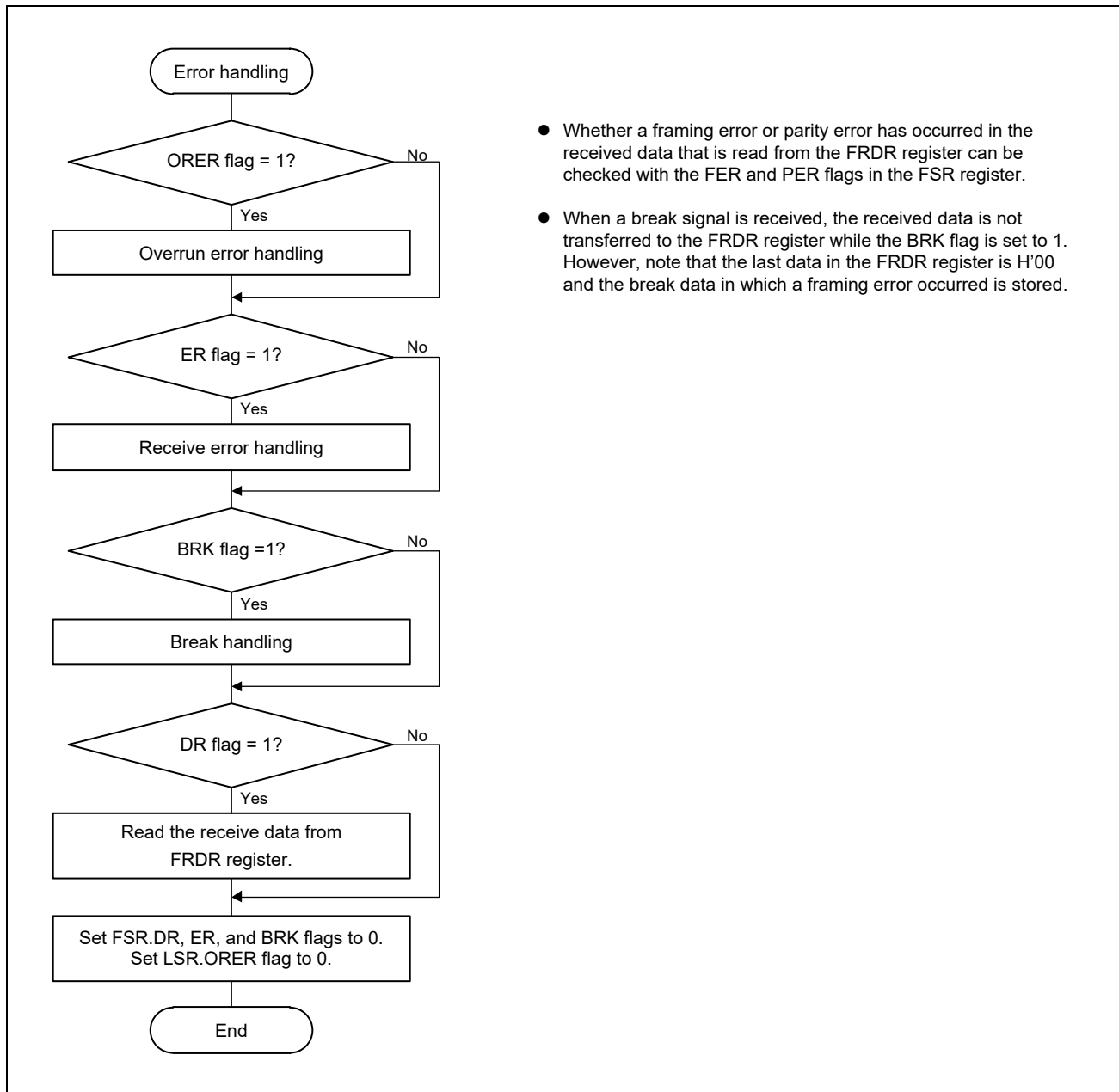

Figure 22.7 Sample Flowchart for Receiving Serial Data in Asynchronous Mode (1)



- Whether a framing error or parity error has occurred in the received data that is read from the FRDR register can be checked with the FER and PER flags in the FSR register.
- When a break signal is received, the received data is not transferred to the FRDR register while the BRK flag is set to 1. However, note that the last data in the FRDR register is H'00 and the break data in which a framing error occurred is stored.

Figure 22.8 Sample Flowchart for Receiving Serial Data in Asynchronous Mode (2)

In asynchronous mode, the SCIFA performs serial reception as described below.

1. The SCIFA monitors the communication line, and if a 0 start bit is detected, it performs internal synchronization to start reception.
2. The received data is stored into the RSR register in LSB-to-MSB order (when LSB-first transfer is selected).
3. The parity bit and stop bit are received.

After receiving these bits, the SCIFA carries out the following checks.

- a) Stop bit check: The SCIFA checks whether the stop bit is 1. If there are two stop bits, only the first is checked.
- b) The SCIFA checks whether receive data can be transferred from the receive shift register (RSR) to the receive FIFO data register (FRDR).
- c) Parity bit check: The SCIFA checks whether the parity bit is an expected value.
- d) Overrun error check: The SCIFA checks whether the ORER flag is 0, indicating that the overrun error has not occurred.
- e) Break check: The SCIFA checks whether the BRK flag is 0, indicating that the break state is not set.

If all the above checks are passed, the receive data is stored in the FRDR register.

NOTE

When a parity error or a framing error occurs, reception is not suspended.

4. When receive data units equaling or exceeding the specified reception trigger number are stored in the receive FIFO data register (FRDR) and the RDF flag is changed to 1, a receive FIFO data full interrupt (RXI) request is generated while the RIE bit in the SCR register is set to 1. When the quantity of data in the FRDR register falls below the specified reception trigger number and the RIE bit in the SCR register is set to 1, a receive data ready interrupt (DRI) request is generated if no next data is received after the elapse of 15 ETUs*¹ from the last stop bit (the DR flag in the FSR register is 1). When the ER flag in the FSR register is changed to 1, a receive error interrupt (ERI) request is generated while the RIE or REIE bit in the SCR register is set to 1. When the BRK or ORER flag is changed to 1 in the FSR register, a break reception interrupt (BRI) request is generated while the RIE or REIE bit in the SCR register is set to 1.

Note 1. It is equivalent to 1 and half frames of 8-bit format with one stop bit (ETU: Element Time Unit).

Figure 22.9 shows an example of the operation for reception in asynchronous mode.

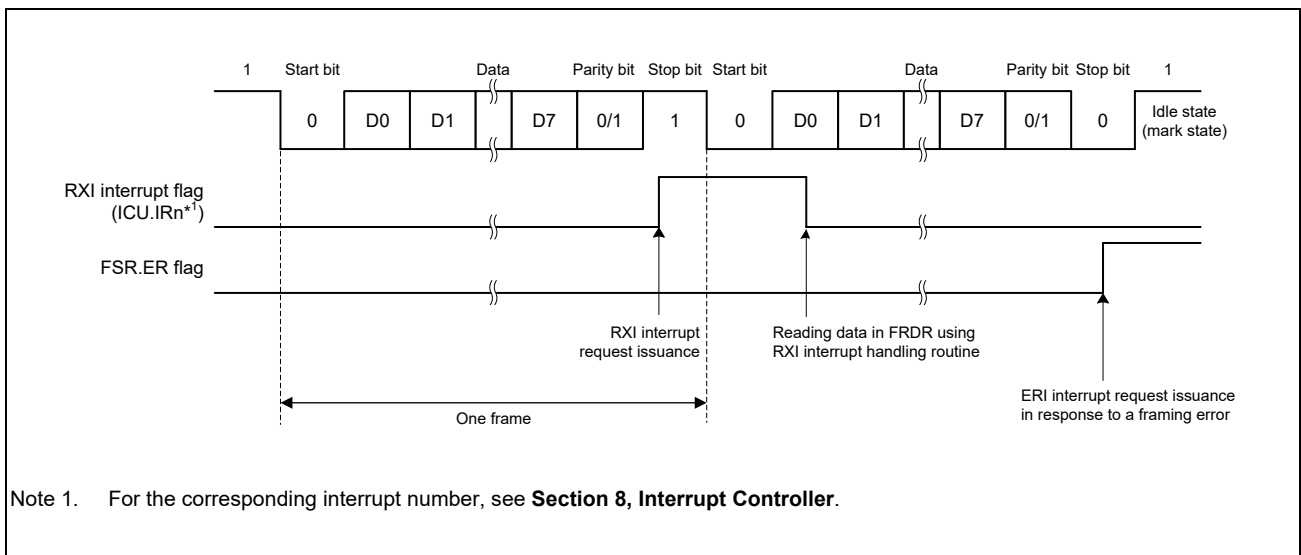

Figure 22.9 Example of SCIFA Receive Operation in Asynchronous Mode (8-Bit Data with Parity and One Stop Bit when LSB-First Transfer is Selected)

- When modem control is enabled, the RTS# signal that indicates the FRDR register has space is output. When the RTS# pin is at low level, reception is possible. The RTS# pin being at the high level indicates that the number of entries in the FRDR register is equal to or greater than the threshold for output of the active level of the RTS# signal and that the transmission of further data needs to be suspended until the FRDR register has enough space. **Figure 22.10** shows an example of the operation for reception in asynchronous mode when using the modem control function.

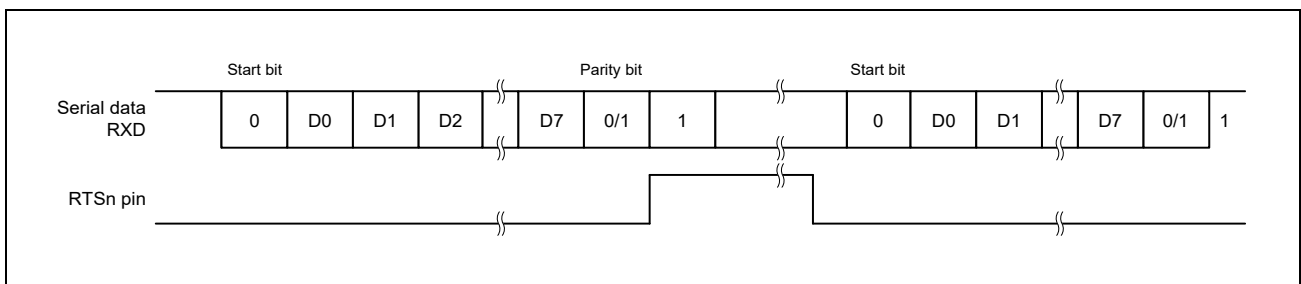

Figure 22.10 Example of SCIFA Receive Operation in Asynchronous Mode Using Modem Control Function (RTS#)

22.3.3 Operation in Clock Synchronous Mode

In clock synchronous mode, the SCIFA transmits and receives data in synchronization with clock pulses. This mode is suitable for high-speed serial communication.

Full-duplex communication is possible because the SCIFA transmitter and receiver are independent and share the same clock. Since the transmitter and the receiver have 16-stage FIFO buffers, respectively, continuous transmission or reception is possible by reading or writing data while transmission or reception is in progress.

Figure 22.11 shows the general format in clock synchronous serial communication.

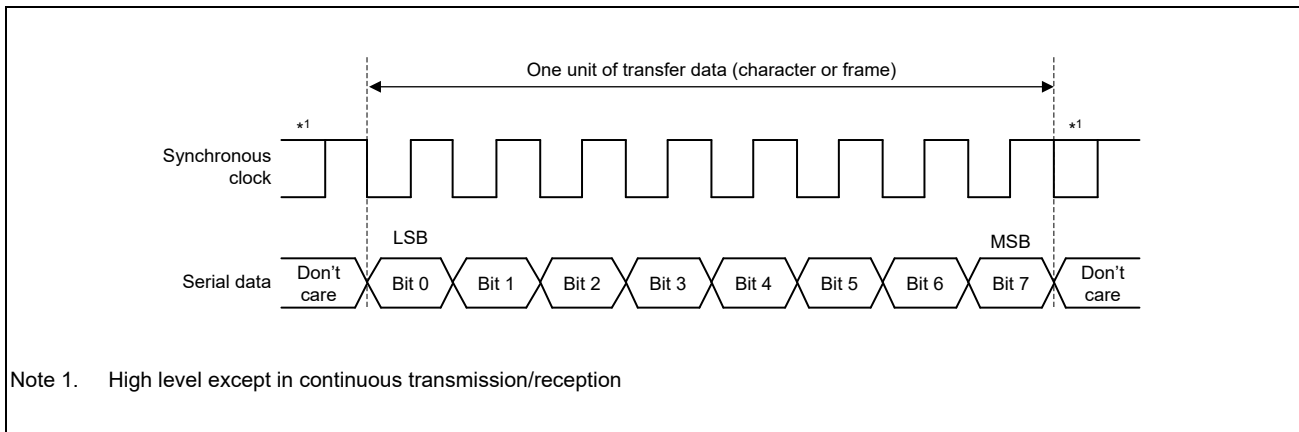

Figure 22.11 Data Format in Clock Synchronous Communication (when LSB-First Transfer is Selected)

In clock synchronous serial communication, each data bit is output on the communication line from one falling edge of the synchronous clock to the next. Data is guaranteed valid at the rising edge of the synchronous clock.

In each character, the serial data bits are transmitted in order from the LSB (first) to the MSB (last). After output of the MSB, the communication line remains in the state of the MSB (when LSB-first transfer is selected).

In clock synchronous mode, the SCIFA receives data by synchronizing with the rising edge of the synchronous clock.

(1) Transmit/Receive Formats

The data length is fixed at eight bits.

No parity bit can be added.

(2) Clock

An internal clock generated by the on-chip baud rate generator or an external clock input from the SCK pin can be selected as the SCIFA transmit/receive clock according to the settings of the CM bit in the serial mode register (SMR) and the CKE[1:0] bits in the serial control register (SCR).

When the SCIFA operates on an internal clock, it outputs the synchronous clock signal at the SCK pin. Eight synchronous clock pulses are output per transmitted or received character. Unless the SCIFA is transmitting or receiving, the synchronous clock signal remains in the high state. When the SCIFA only receives data on an internal clock, the internal clock signal outputs while the RE bit in the SCR register is 1 until the number of data units in the receive FIFO reaches the specified reception trigger number.

(3) Transmitting and Receiving Data

SCIFA Initialization (in Clock Synchronous Mode)

Before transmitting or receiving, clear the TE and RE bits to 0 in the serial control register (SCR), and then initialize the SCIFA by performing the following procedure.

Similarly, before changing the mode or communication format, clear the TE and RE bits to 0, and then change it by performing the following procedure. Clearing TE to 0 initializes the transmit shift register (TSR). Clearing RE to 0, however, does not initialize the RDF, PER, FER, and ORER flags and the receive FIFO data register (FRDR), which retain their previous contents.

Figure 22.12 shows a sample flowchart for initializing the SCIFA in clock synchronous mode.

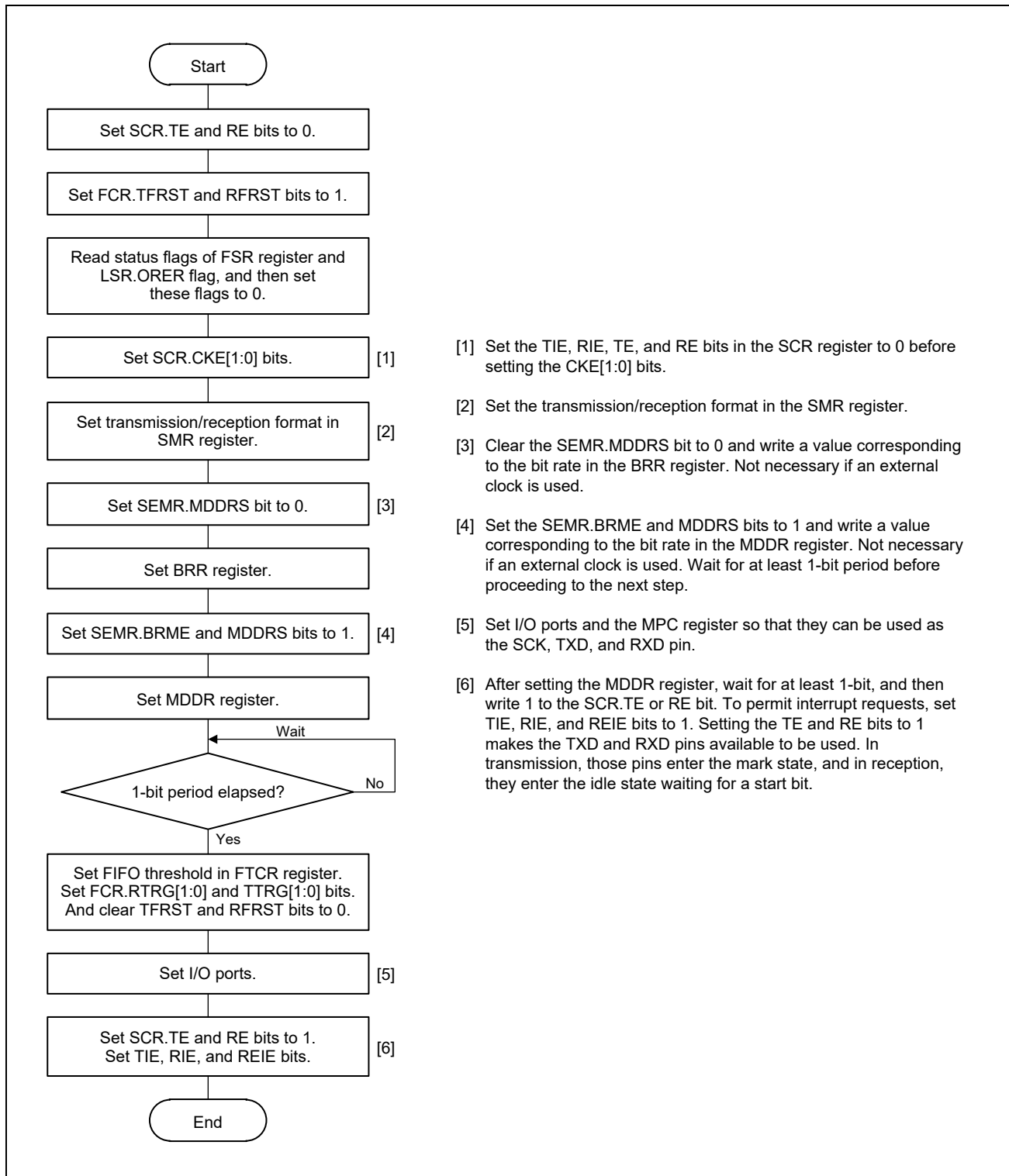

Figure 22.12 Sample Flowchart for SCIFA Initialization in Clock Synchronous Mode

Transmitting Serial Data (in Clock Synchronous Mode)

Figure 22.13 shows a sample flowchart for transmitting serial data in clock synchronous mode.

Follow the procedure given below for serial data transmission after enabling the SCIFA for transmission.

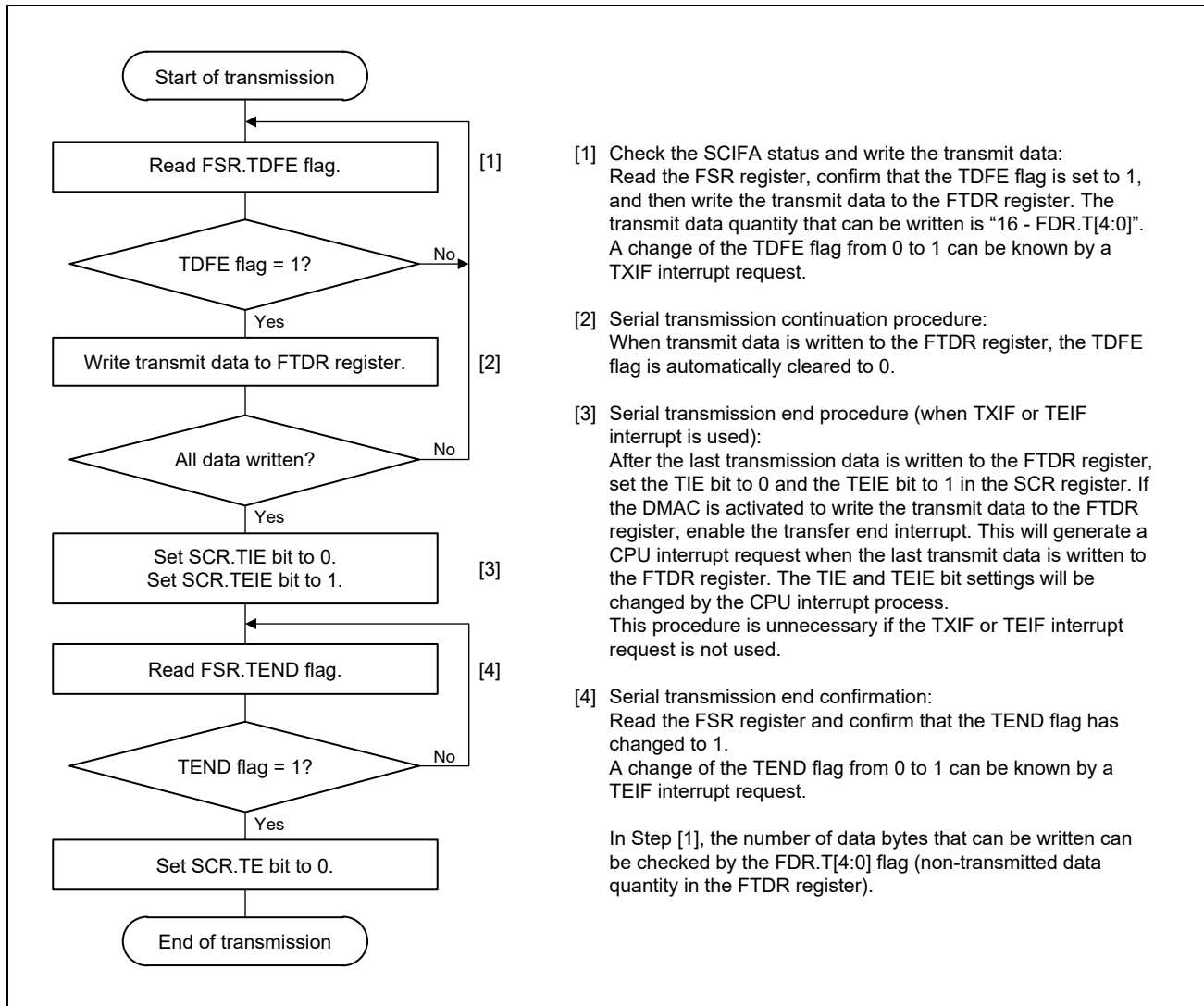

Figure 22.13 Sample Flowchart for Transmitting Serial Data in Clock Synchronous Mode

In clock synchronous mode, the SCIFA performs serial transmission as described below.

1. When data is written into the transmit FIFO data register (FTDR) by the TXI interrupt processing routine, the SCIFA transfers the data from the FTDR register to the transmit shift register (TSR) and starts transmission. Confirm that the TDFE flag in the serial status register (FSR) is set to 1 before writing transmit data to the FTDR register. The number of data bytes that can be written is “16 minus the specified number of non-transmitted data units”.
2. When data is transferred from the FTDR register to the TSR register and transmission is started, consecutive transmit operations are performed until there is no transmit data left in the FTDR register. When the number of transmit data bytes in the FTDR register becomes equal to or less than the transmission trigger number set in the FIFO control register (FCR) or FIFO trigger control register (FTCR), the TDFE flag in the FSR register is set. If the TIE bit in the serial control register (SCR) is set to 1 at this time, a transmit-FIFO-data-empty interrupt (TXI) request is generated.

If clock output mode is selected, the SCIFA outputs eight synchronous clock pulses. If an external clock source is selected, the SCIFA outputs data in synchronization with the input clock. Data is output from the TXD pin in order from the LSB (b0) to the MSB (b7) (when LSB-first transfer is selected).

3. The SCIFA checks the transmit data of the FTDR register at the timing for sending the MSB (bit 7). If data is present, the data is transferred from the FTDR register to the TSR register, and then serial transmission of the next frame is started. If there is no data, the TXD pin holds the output level of the last data after the TEND flag in the FSR register is set to 1 and the MSB (bit 7) is output.
4. After the end of serial transmission, the SCK pin is held in the high state.

Figure 22.14 shows an example of SCIFA transmit operation in clock synchronous mode.

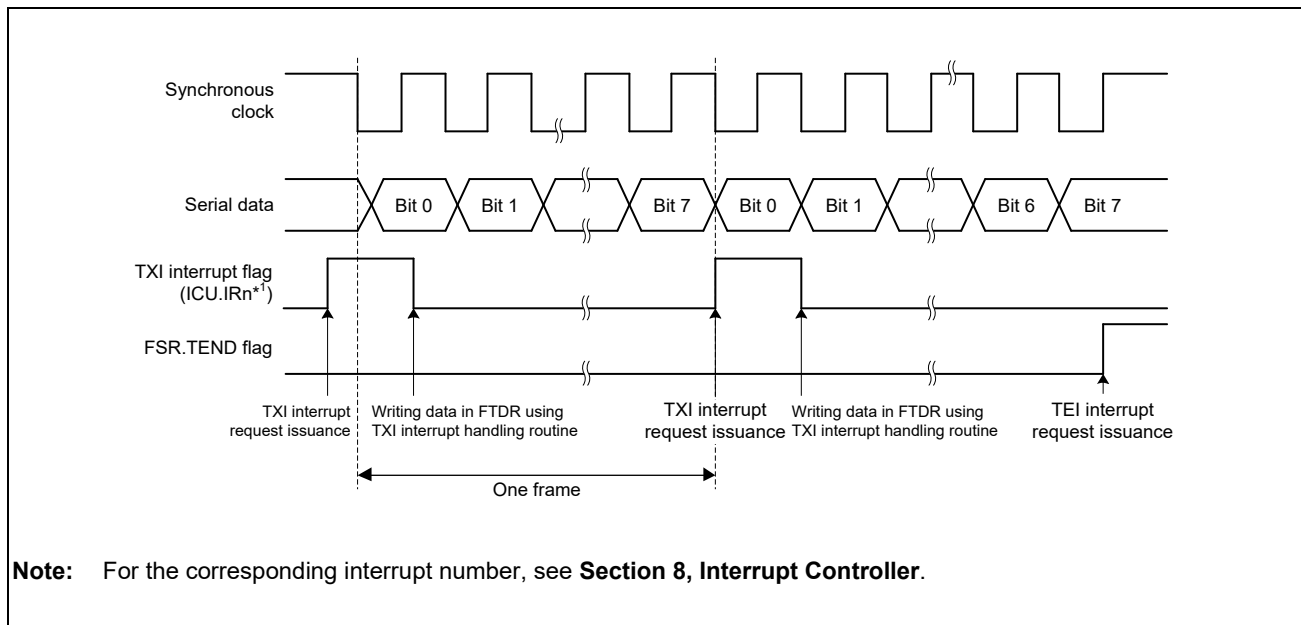

Figure 22.14 Example of SCIFA Transmit Operation in Clock Synchronous Mode
(when LSB-First Transfer is Selected)

Receiving Serial Data (in Clock Synchronous Mode)

Figure 22.15 and Figure 22.16 show sample flowcharts for receiving serial data in clock synchronous mode.

Follow the procedure given below for serial data reception after enabling the SCIFA for reception. When switching from asynchronous mode to clock synchronous mode without SCIFA initialization, make sure that the ORER, PER, and FER flags in the line status register (LSR) are cleared to 0.

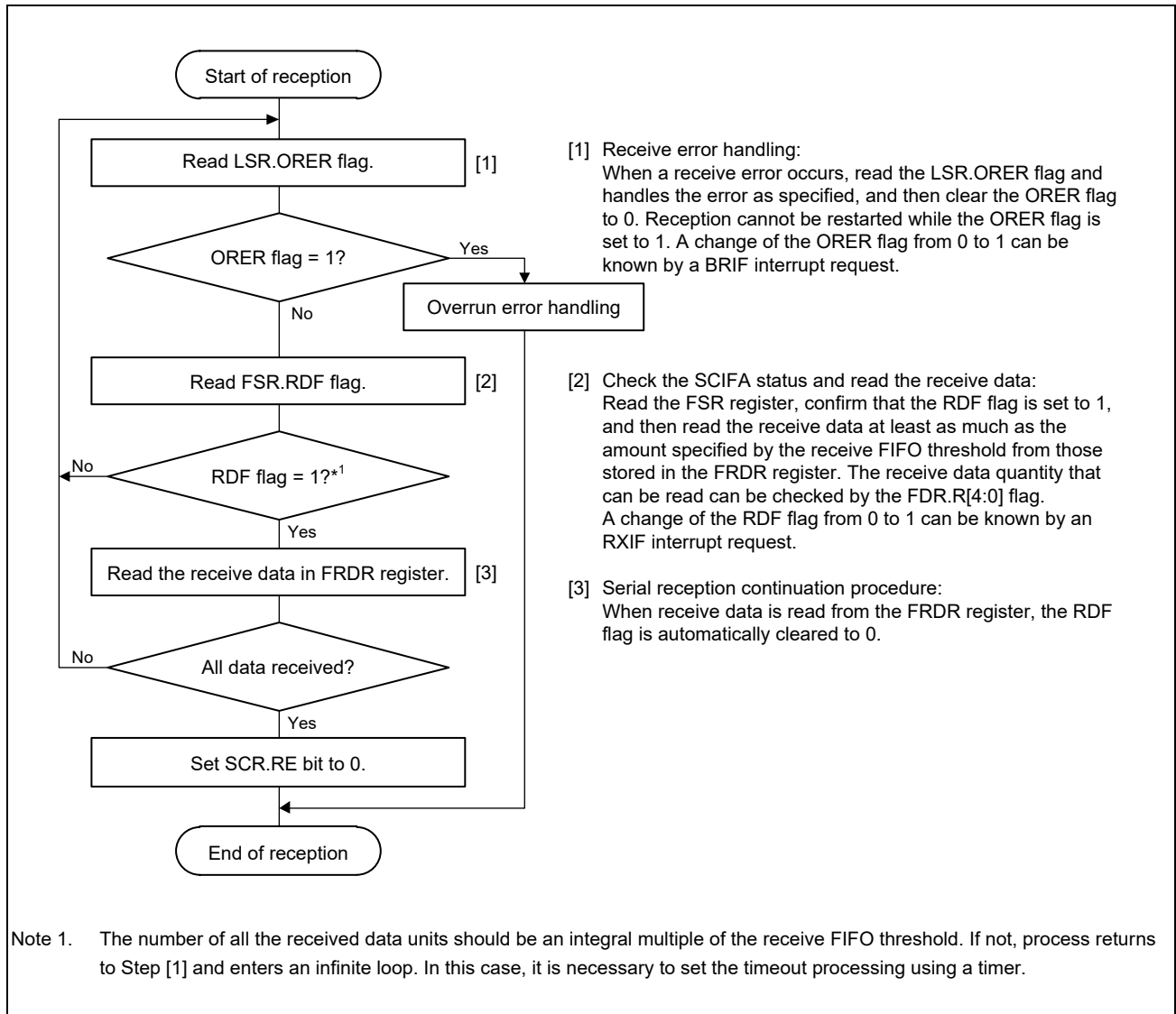

Figure 22.15 Sample Flowchart for Receiving Serial Data in Clock Synchronous Mode

In clock synchronous mode, the SCIFA performs serial reception as described below.

1. The SCIFA synchronizes with the synchronous clock input or output and starts reception.
2. Receive data is stored into the receive shift register (RSR) in order from the LSB to the MSB (when LSB-first transfer is selected). After receiving the data, the SCIFA checks whether the receive data can be transferred from the RSR register to the FRDR register. If data can be transferred, the SCIFA stores the received data in the FRDR register. If an overrun error is detected during the error check, further reception is not performed.
3. After the received data units equaling or exceeding the specified reception trigger number are stored in the FRDR register and the RDF flag is set to 1, a receive-data-full interrupt (RXI) request is generated when the RIE bit in the serial control register (SCR) is set to 1. When the ORER flag in the line status register (LSR) is set to 1 and the RIE or REIE bit in the SCR register is also set to 1, a break interrupt (BRI) request is generated.

Figure 22.16 shows an example of SCIFA receive operation in clock synchronous mode.

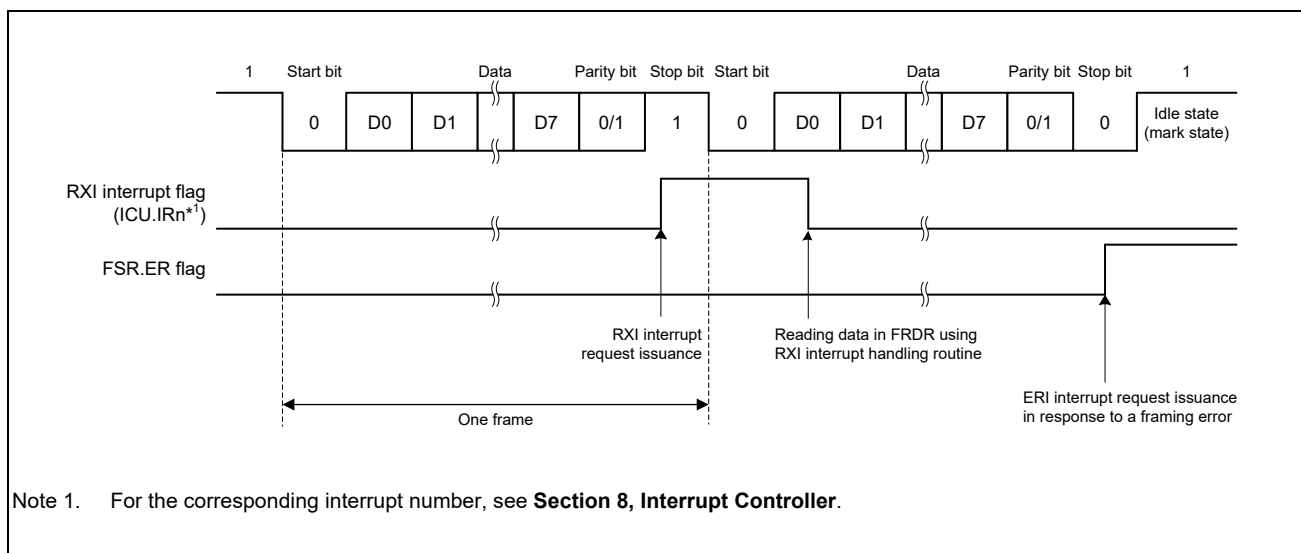

Figure 22.16 Example of SCIFA Receive Operation (when LSB-First Transfer is Selected)

Transmitting and Receiving Serial Data Simultaneously (in Clock Synchronous Mode)

Figure 22.17 shows a sample flowchart for transmitting and receiving serial data simultaneously in clock synchronous mode.

In simultaneous transmission/reception of serial data, number of receive data = number of transmit data = number of transmit data to be written to the FTDR register.

Follow the procedure given below for the simultaneous transmission/reception of serial data, after enabling the SCIFA for transmission/reception.

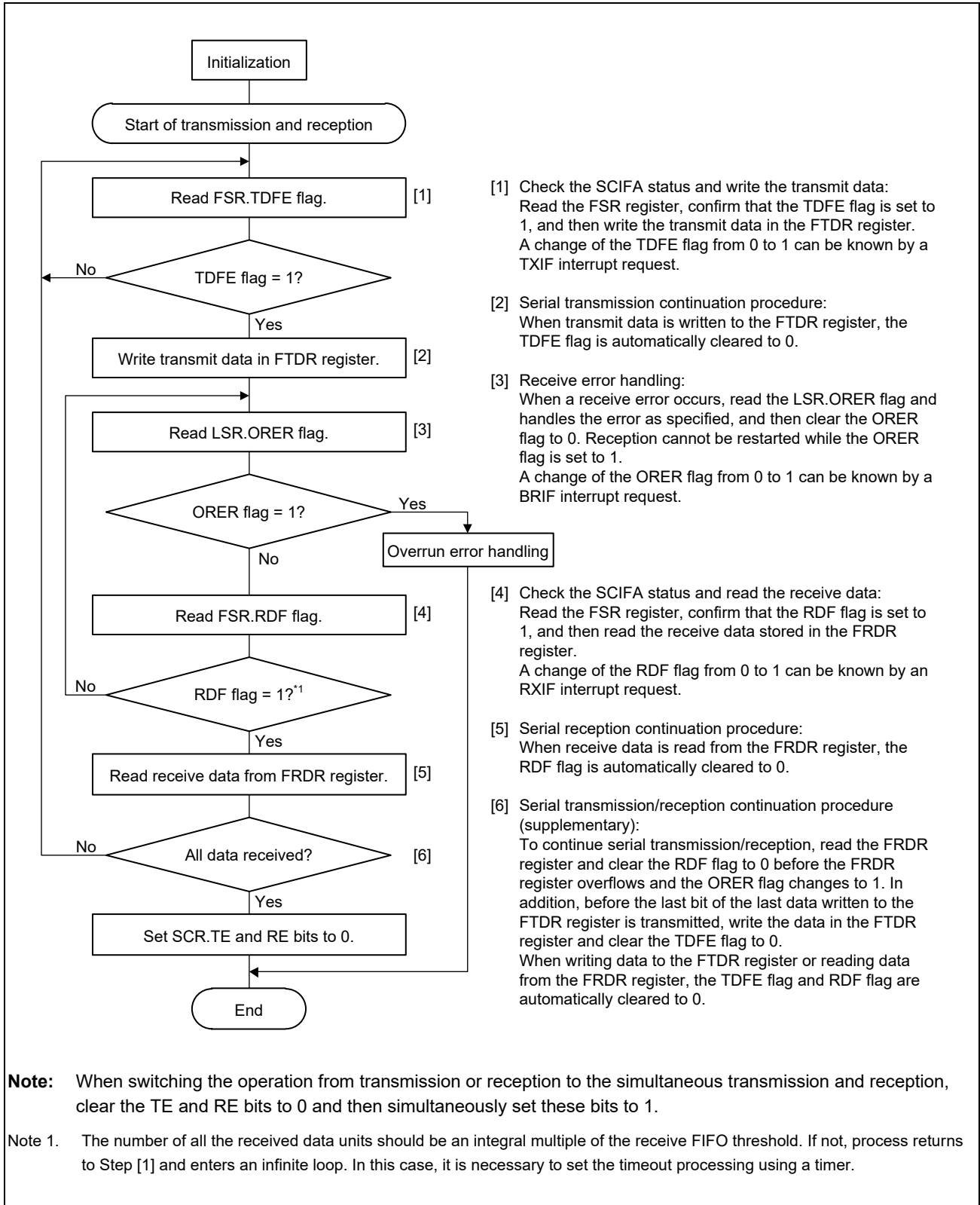

Figure 22.17 Sample Flowchart for Simultaneous Transmitting/Receiving Serial Data in Clock Synchronous Mode

22.4 Bit Rate Modulation

Using the bit rate modulation, the bit rate can be corrected by skipping the specified number of clock pulses input to the baud rate generator. To correct the bit rate, only the number of clock pulses specified in the MDDR register are enabled among 256 internal clock pulses specified by the CKS1 and CKS0 bits in the SMR register in a way that forms average intervals.

Figure 22.18 shows an example where $P0\phi$ is selected by the CKS[1:0] bits in SMR and BRR and MDDR are set to 0 and 160, respectively, in asynchronous mode. In this example, the cycle of the base clock is evenly corrected ($256/160$) and the bit rate is also corrected ($160/256$). Note that skipping an internal clock causes bias and expansion or contraction is generated in the pulse width of the base clock.

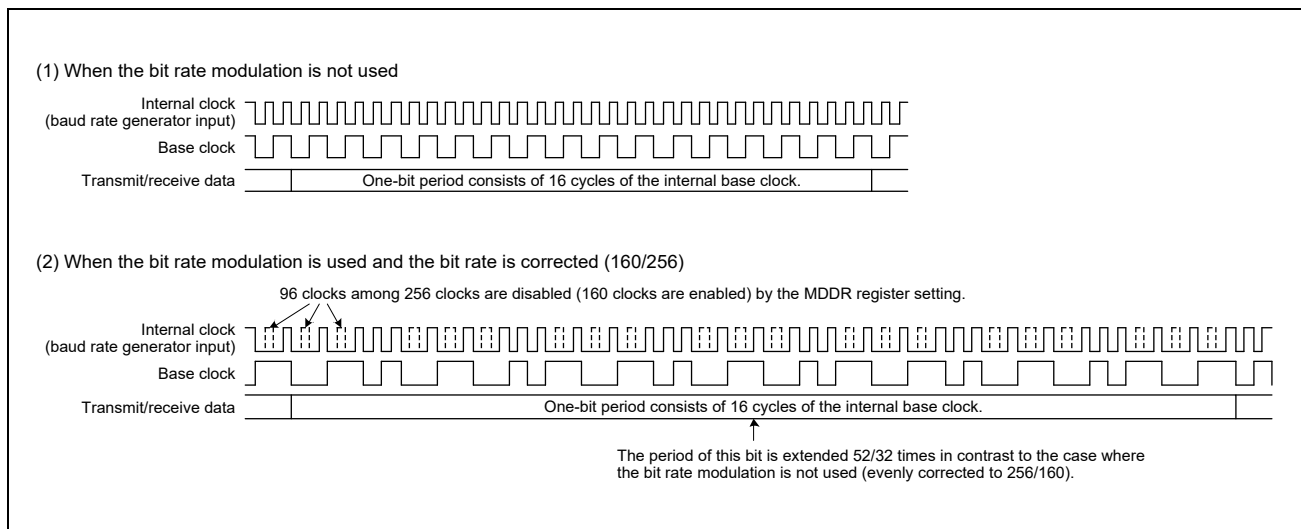

Figure 22.18 Example of Internal Base Clock when Bit Modulation is Used

22.5 Interrupt Sources

The SCIFA has six interrupt sources: transmit-FIFO-data-empty (TXI), receive-error (ERI), receive-FIFO-data-full (RXI), break (BRI), transmit-end (TEI), receive-data-ready (DRI). The TEI, DRI, ERI, and BRI interrupts share the same vector number.

Table 22.19 shows the interrupt sources and priority. The interrupt sources can be enabled or disabled using the TIE, RIE, REIE, TEIE bits in the SCR register and are separately input to the interrupt controller.

When the quantity of transmit data written in the FTDR register as a result of transmission is equal to or less than the specified transmission trigger number, the TDFE flag in the serial status register (FSR) is set to 1 and a TXI interrupt request is generated.

When the data units equaling or exceeding the specified transmission trigger number are stored in the receive FIFO register (FRDR) and the RDF flag in the FSR register is set to 1, a receive data full interrupt (RXI) request is generated. When the quantity of received data in the FRDR register is below the specified reception trigger number and no next data has been received yet even after the period of 15 ETUs elapsed*¹ from the last stop bit, the DR flag in the FSR register is set to 1 and a receive data ready interrupt (DRI) request is generated. In clock synchronous mode, a DRI interrupt request is not generated.

When the BRK flag in the FSR register or the ORER flag in the LSR register is set to 1, a BRI interrupt request is issued. When the ER flag in the FSR register is set to 1, an ERI interrupt request is issued.

When the TEND flag in the FSR register is set to 1, a TEI interrupt request is issued.

When the RIE bit is cleared to 0 and the REIE bit in the SCR register is set to 1, an ERI and a BRI interrupt requests are issued but an RXI interrupt request is not.

An TXI interrupt indicates that transmit data can be written and an RXI interrupt indicates that receive data is stored in the FRDR register.

Note 1. It is equivalent to 1 and half frames of 8-bit format with one stop bit (ETU: Element Time Unit).

Table 22.19 SCIFA Interrupt Sources

Name	Level/Edge	Interrupt Source	Interrupt Enable Bit	DMAC Activation	Priority
BRI	Level	Interrupt caused by break (BRK) or overrun (ORER).	RIE or REIE	Impossible	High
ERI	Level	Interrupt caused by framing or parity (ER).	RIE or REIE	Impossible	↑ ↓
RXI	Level	Interrupt caused by receive FIFO data full (RDF).	RIE	Possible	
TXI	Level	Interrupt caused by transmit FIFO data empty (TDFE).	TIE	Possible	
TEI	Level	Interrupt caused by transmit end (TEND).	TEIE	Impossible	
DRI	Level	Interrupt caused by receive data ready (DR).	RIE	Impossible	

Note: The TEI and DRI interrupts share the same vector number.

The ERI and BRI interrupts share the same vector number.

If CPU processing is used, clear the flag after the block transfer. If the DMAC is activated, access to the flags is prohibited.

22.6 Serial Port Register (SPTR) and SCIFA-Related Pins

Figure 22.19 to Figure 22.22 show the relationships between the SPTR register and the SCIFA-related pins.

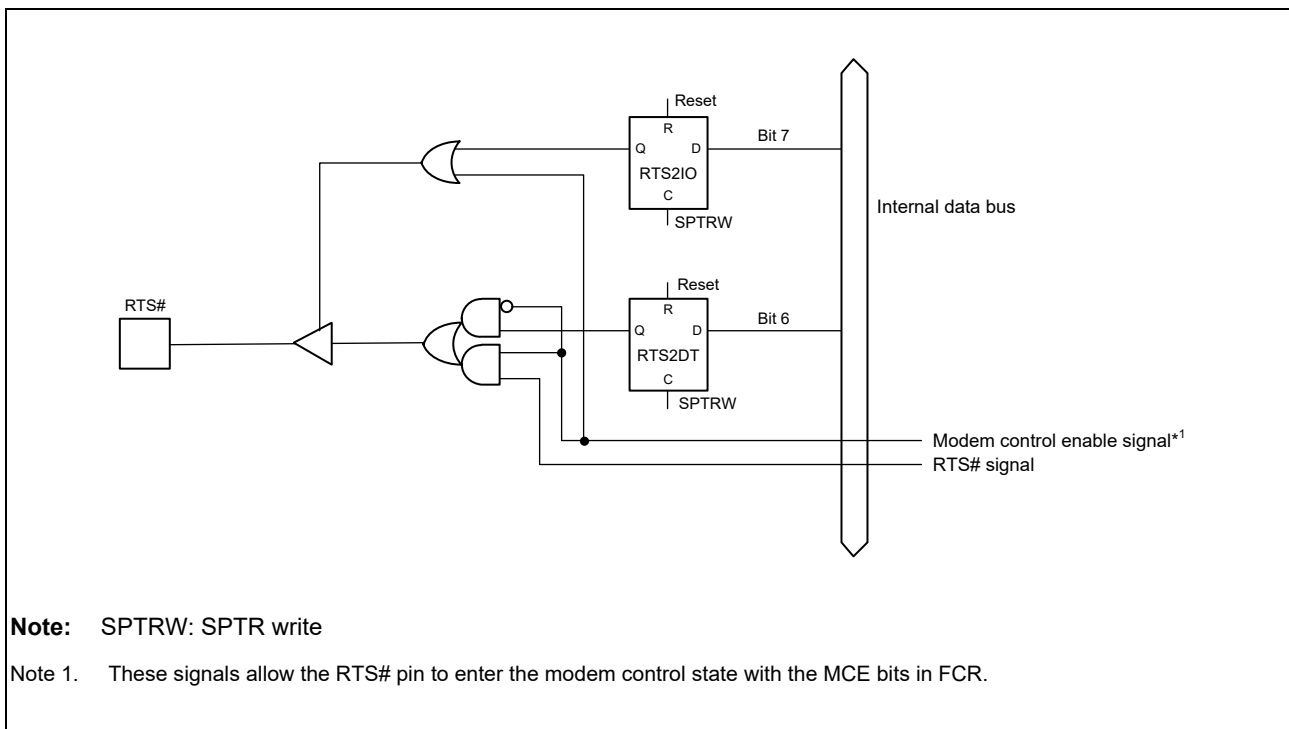

Figure 22.19 RTS2IO Bit and RTS2DT Bit in the SPTR Register, and RTS# Pin

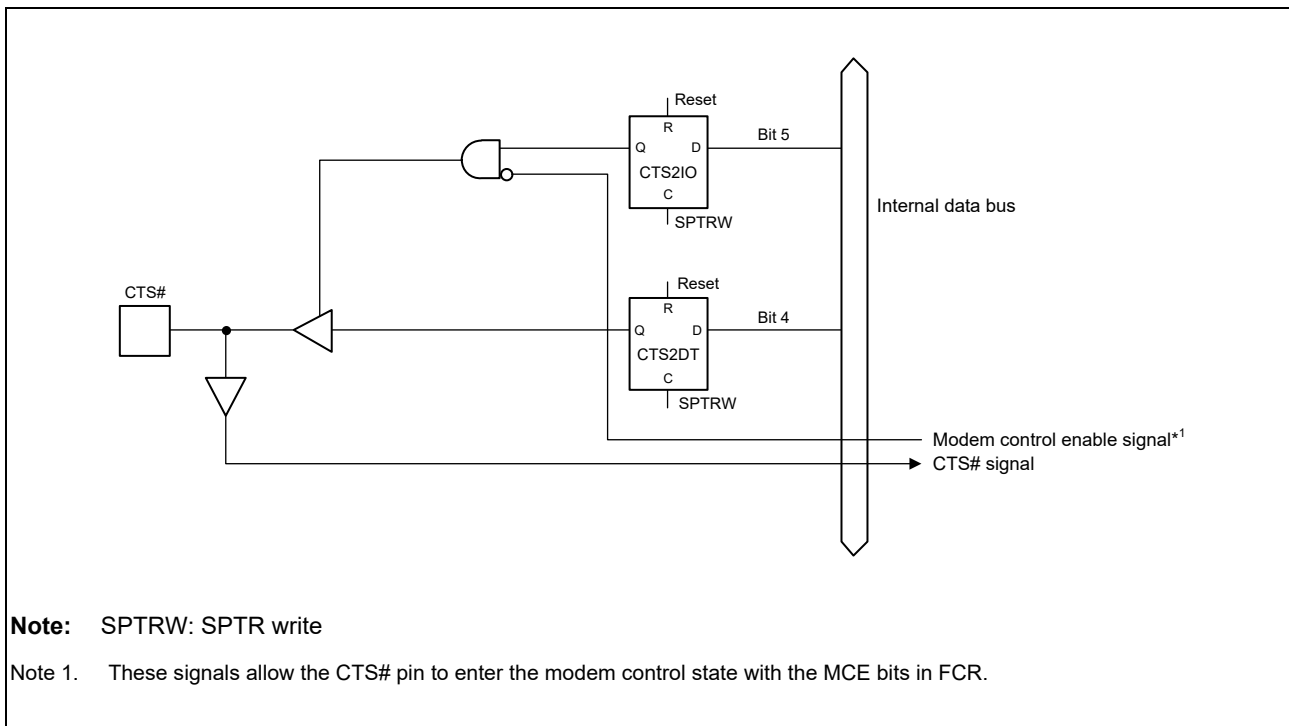

Figure 22.20 CTS2IO Bit and CTS2DT Bit in the SPTR Register, and CTS# Pin

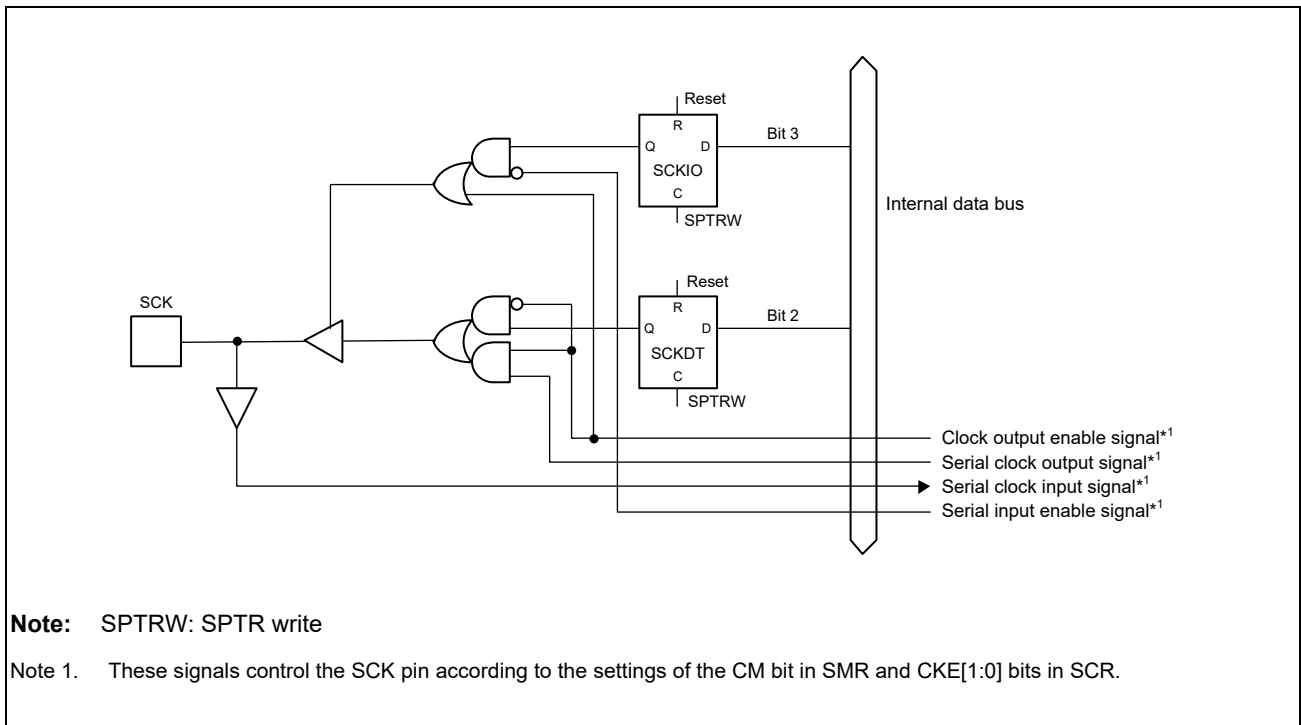

Figure 22.21 SCKIO Bit and SCKDT Bit in the SPTR Register, and SCK Pin

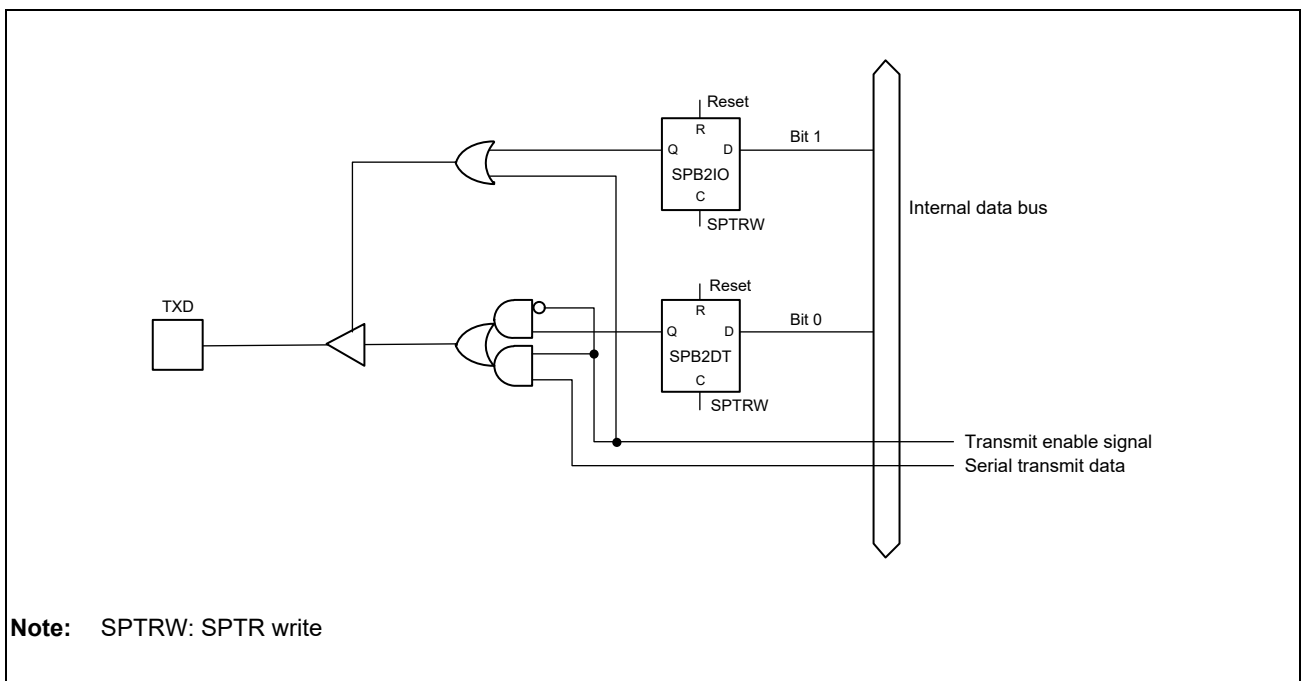

Figure 22.22 SPB2IO Bit and SPB2DT Bit in the SPTR Register, and TXD Pin

22.7 Noise Cancellation

Figure 22.23 shows the configuration of the noise filter used for noise cancellation. The noise filter consists of a two-stage flip-flop circuits and a match detection circuit. When the input signals of the noise filter and the output signals of the two-stage flip-flop circuits completely match, the matched level is conveyed as an internal signal. Unless otherwise matched, the previous value is retained. (When the levels sampled on three consecutive cycles of the sampling clock of the noise filter match, the signal is considered valid. If three consecutive sampled values do not match, the signal is considered to be noise rather than a received signal).

In asynchronous mode, the noise cancellation can be applied to the receive signal input to the RXDn pin. The receive level of the RXDn pin is taken in the flip-flop circuit of the noise filter on the base clock (the clock with a frequency 16 or 8 times the transfer rate*¹).

If the base clock is stopped once with the noise filter enabled and then the base clock input is restarted again, the noise filter operation resumes from the state where the clock was stopped. When SCR.RE is set to 0 during input of the base clock, the noise filter outputs 0 as the internal RxDn signal. The internal match detector continues operating even while operations for reception are stopped, and the result from the last time previous consecutive samples matched is output at the same time as operations for reception are resumed.

Note 1. A frequency 16 times bit rate when the SEMR.ABCS0 bit and the SEMR.BGDM bit are both 0, and a frequency 8 times bit rate when either the SEMR.ABCS0 bit or the SEMR.BGDM bit is 1.

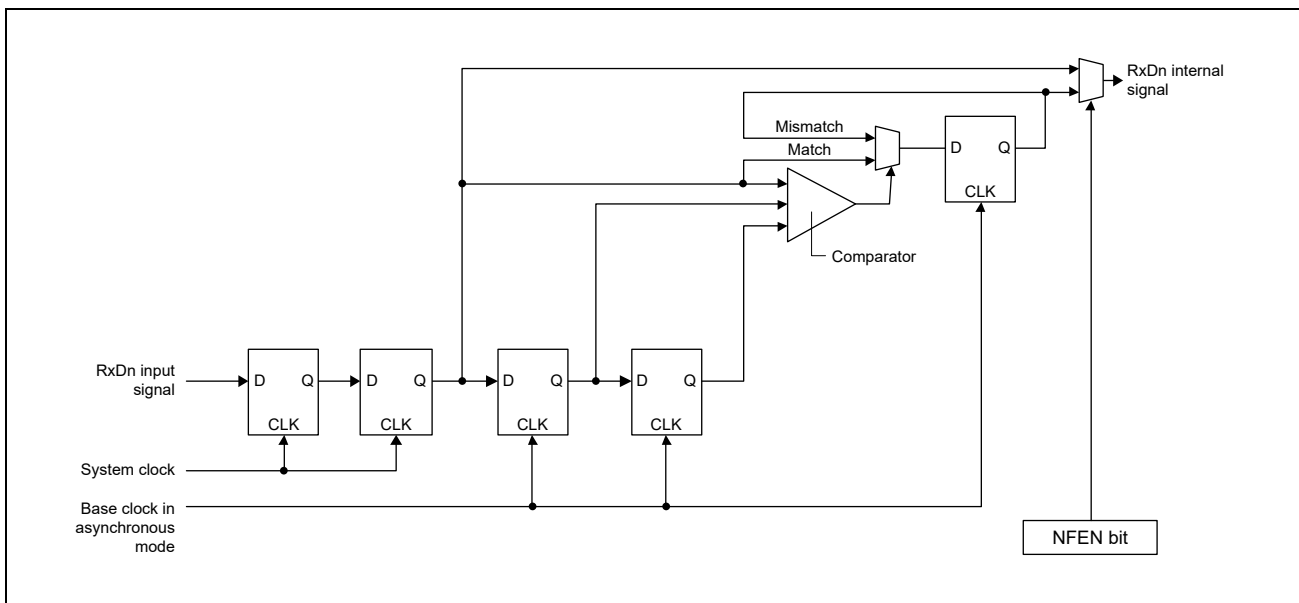

Figure 22.23 Block Diagram of Digital Noise Filter Circuit

22.8 Usage Notes

The following is the notes on using the SCIFA.

22.8.1 FTDR Register Writing and TDFE Flag

The TDFE flag in the serial status register (FSR) is set when the number of transmit data bytes written in the transmit FIFO data register (FTDR) has fallen below the transmission trigger number set by bits TTRG[1:0] in the FIFO control register (FCR) or bits TFTC[4:0] in the FIFO trigger control register (FTCR). After the TDFE flag is set, transmit data up to the number of empty bytes in the FTDR register can be written, allowing efficient continuous transmission.

However, if the number of data bytes written in the FTDR register is equal to or less than the specified transmission trigger number, the TDFE flag will be set to 1 again even after being read as 1 and cleared to 0.

The number of transmit data bytes in the FTDR register can be checked by the 8 higher-order bits of the FIFO data count register (FDR).

22.8.2 FRDR Register Reading and RDF Flag

The RDF flag in the serial status register (FSR) is set when the number of receive data bytes in the receive FIFO data register (FRDR) has become equal to or greater than the reception trigger number set by bits RTRG[1:0] in the FIFO control register (FCR) or bits RFTC[4:0] in the FIFO trigger control register (FTCR). After the RDF flag is set, receive data equivalent to the trigger number can be read from the FRDR register, allowing efficient continuous reception.

However, if the number of data bytes in the FRDR register exceeds the reception trigger number, the RDF flag will be set to 1 again even after being read as 1 and cleared to 0.

The number of receive data bytes in the FRDR register can be checked by the 8 lower-order bits of the FIFO data count register (FDR).

22.8.3 Break Detection and Processing

When a framing error (FER) is detected, a break signal can be detected by reading the RXD pin value directly. In a break, the input from the RXD pin becomes all low. Therefore, the FER flag in the serial status register (FSR) is set to 1 and the parity error flag (PER) may also be set to 1.

Upon detection of a break signal, the SCIFA stops the received data transfer to the FRDR register but continues the receive operation.

22.8.4 Writing to the SPTR Register

b6, b4, b2, and b0 of the SPTR register respectively indicate the input status of their corresponding pins. (See the description of each bit of **Section 22.2.12, Serial Port Register (SPTR)** for details.)

Writings to these bits in 1-bit unit are handled as read-modify-write, which may lead to undesired values to be written. To avoid this, when modifying the SPB2DT or SPB2IO bit, for example, write the other bit (the bit used in combination) at the same time.

22.8.5 Break Signal Transmission

The output signal from the TXD pin is determined by the SPB2IO bit and the SPB2DT bit in the serial port register (SPTR). The break signal can be sent by using these bits.

The TXD pin does not function as a transmit data output pin during the period from when the SCIFA is initialized to when the TE bit in the SCR register is set to 1 (transmission possible). The TXD pin status during this period is replaced by the SPB2DT bit value. Therefore, the SPB2IO and SPB2DT bits in the SPTR register must have been set to 1 (high output) at first (mark (high) status).

To transmit the break signal during serial transmission, set the SPB2IO bit in the SPTR register to 1, clear the SPB2DT bit to 0 (specify a low level), and then clear the TE bit in the SCR register to 0 (transmission stop). Clearing the TE bit to 0 initializes the transmitter regardless of the current transmission status, and outputs a low level from the TXD pin.

22.8.6 Receive Data Sampling Timing and Receive Margin in Asynchronous Mode

The SCIFA operates on a base clock with a frequency 16 times the transfer rate*¹. In reception, the SCIFA internally latches the received data at the rising edge of the eighth base clock pulse*¹. The timing is shown in **Figure 22.24**.

Note 1. This is an example when the SEMR.ABCS0 bit is 0. When the ABCS0 bit is 1, a frequency of 8 times the bit rate is used as a base clock and receive data is sampled at the rising edge of the 4th pulse of the base clock. The receive margin in asynchronous mode can therefore be expressed as shown in equation 1.

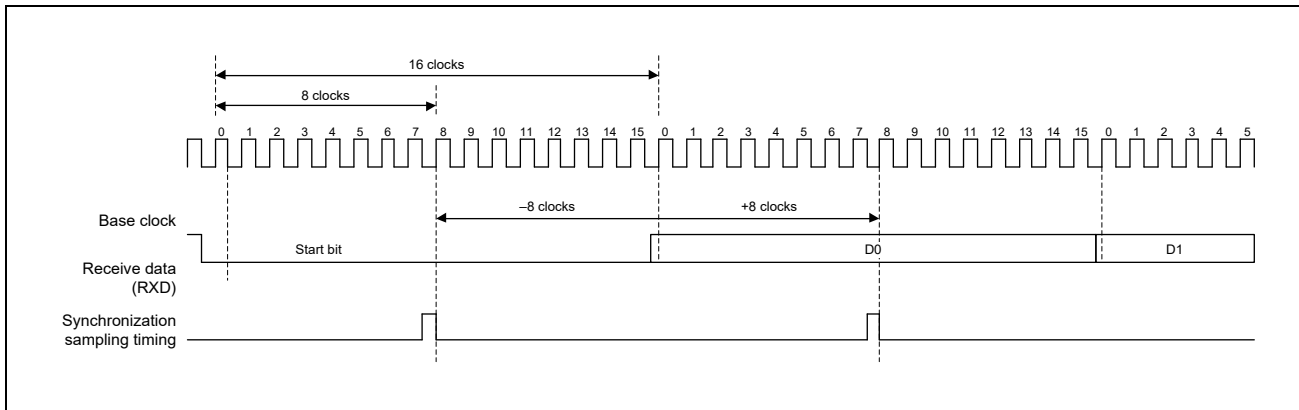

Figure 22.24 Receive Data Sampling Timing in Asynchronous Mode

The receive margin in asynchronous mode can therefore be expressed as shown in equation 1.

[Equation 1]

$$M = \left\{ 0.5 - \frac{1}{2N} - (L - 0.5)F - \frac{|D - 0.5|}{N} (1 + F) \right\} \times 100[\%]$$

Where: M: Receive margin (%)

N: Ratio of clock frequency to bit rate (N = 16)

D: Clock duty (D = 0 to 1.0)

L: Frame length (L = 9 to 12)

F: Absolute deviation of clock frequency

From equation 1, if F = 0 and D = 0.5, the receive margin is 46.875%, as given by equation 2.

[Equation 2]

When D = 0.5 and F = 0:

$$M = (0.5 - 1/(2 \times 16)) \times 100\% = 46.875\%$$

This is a theoretical value. A reasonable margin to allow in system designs is 20% to 30%.

22.8.7 Note on FER Flag and PER Flag in Serial Status Register (FSR)

The FER flag and PER flag in the serial status register (FSR) are status flags that apply to next entry to be read from the receive FIFO data register (FRDR). After the CPU or DMAC reads the receive FIFO data register, the flags of framing errors and parity errors in the receive data will be cleared. To check the received data for the states of framing errors and parity errors, only read the receive FIFO data register after reading the serial status register.

22.8.8 Notes on External Clock Input in Clock Synchronous Mode

Before setting the TE and RE bits in the serial control register (SCR) to 1, wait for four or more cycles of the peripheral operating clock after the external clock (SCK) is changed from 0 (low) to 1 (high). To input the external clock (SCK) (to start communication), wait for one or more cycles of the external clock after the TE and RE bits in the SCR register are set to 1.

22.8.9 Module Standby Mode Setting

SCIFA operation can be disabled or enabled using the standby control register. As the initial setting, the SCIFA operation is halted. Register access is enabled by clearing module standby mode. For details, refer to **Section 42, Low Power Mode**.

22.8.10 Notes on Operation for Reception when an Internal Clock is Selected in Clock Synchronous Mode

When an internal clock is selected as the clock for reception in clock-synchronous mode, if the number of data stored through the receive FIFO data register (FRDR) becomes equal to or greater than the specified reception trigger number, the RDF flag is set, the RXI interrupt request is generated and, at the same time, output of the synchronizing clock and reception of serial data are stopped. Once the number of data are again less than the specified reception trigger number, output of the synchronizing clock and the reception of serial data are restarted. In addition, if an internal clock is selected for reception in clock synchronous mode, the ORER flag is not set to 1 since no overrun occurs. Accordingly, overruns (indicated by the ORER flag) cannot be used as a BRI interrupt source.

23. Serial Communications Interface (SCIg)

This MCU has two independent serial communications interface (SCI) channels. The SCIs consist of the SCI0 and SCI1 modules, referred to in common as “SCIg modules”.

The SCIg modules (SCI0 and SCI1) can handle both asynchronous and clock synchronous serial communications. Asynchronous serial data communications can be carried out with standard asynchronous communications chips such as a Universal Asynchronous Receiver/Transmitter (UART) or Asynchronous Communications Interface Adapter (ACIA). As an extended function in asynchronous communications mode, the SCI also supports smart card (IC card) interfaces conforming to ISO/IEC 7816-3 (standard for Identification Cards).

23.1 Overview

Table 23.1 lists the specifications of the SCIg modules. **Figure 23.1** shows the block diagram of the SCI0 and SCI1 modules.

Table 23.1 SCIg Specifications (1/2)

Item	Description	
Serial communications modes	<ul style="list-style-type: none"> • Asynchronous • Clock synchronous • Smart card interface • IrDA (only for channel 0) 	
Transfer speed	Bit rate specifiable with the on-chip baud rate generator.	
Full-duplex communications	Transmitter: Continuous transmission possible using double-buffer structure. Receiver: Continuous reception possible using double-buffer structure.	
I/O pins	See Table 23.2 .	
Data transfer	Selectable as LSB first or MSB first transfer	
Interrupt sources	Transmit end, transmit data empty, receive data full, and receive error	
Low power consumption function	Module stop state can be set for each channel.	
Asynchronous mode	Data length	7, 8, or 9 bits
	Transmission stop bit	1 or 2 bits
	Parity	Even parity, odd parity, or no parity
	Receive error detection	Parity, overrun, and framing errors
	Hardware flow control	CTS# and RTS# pins can be used in controlling transmission/reception.
	Start-bit detection	Low level or falling edge is selectable.
	Break detection	When a framing error occurs, a break can be detected by reading the RXDn pin level directly.
	Clock source	An internal or external clock can be selected.
	Double-speed mode	Baud rate generator double-speed mode is selectable.
	Multi-processor communications function	Serial communication among multiple processors
	Noise cancellation	The signal paths from input on the RXDn pins incorporate digital noise filters.
Clock synchronous mode	Data length	8 bits
	Receive error detection	Overrun error
	Hardware flow control	CTS# and RTS# pins can be used in controlling transmission/reception.

Table 23.1 SCIg Specifications (2/2)

Item	Description
Smart card interface mode	<p>Error processing</p> <p>An error signal can be automatically transmitted when detecting a parity error during reception</p> <p>Data can be automatically retransmitted when receiving an error signal during transmission</p>
Data type	Both direct convention and inverse convention are supported.
Bit rate modulation function	Correction of outputs from the on-chip baud rate generator can reduce errors.

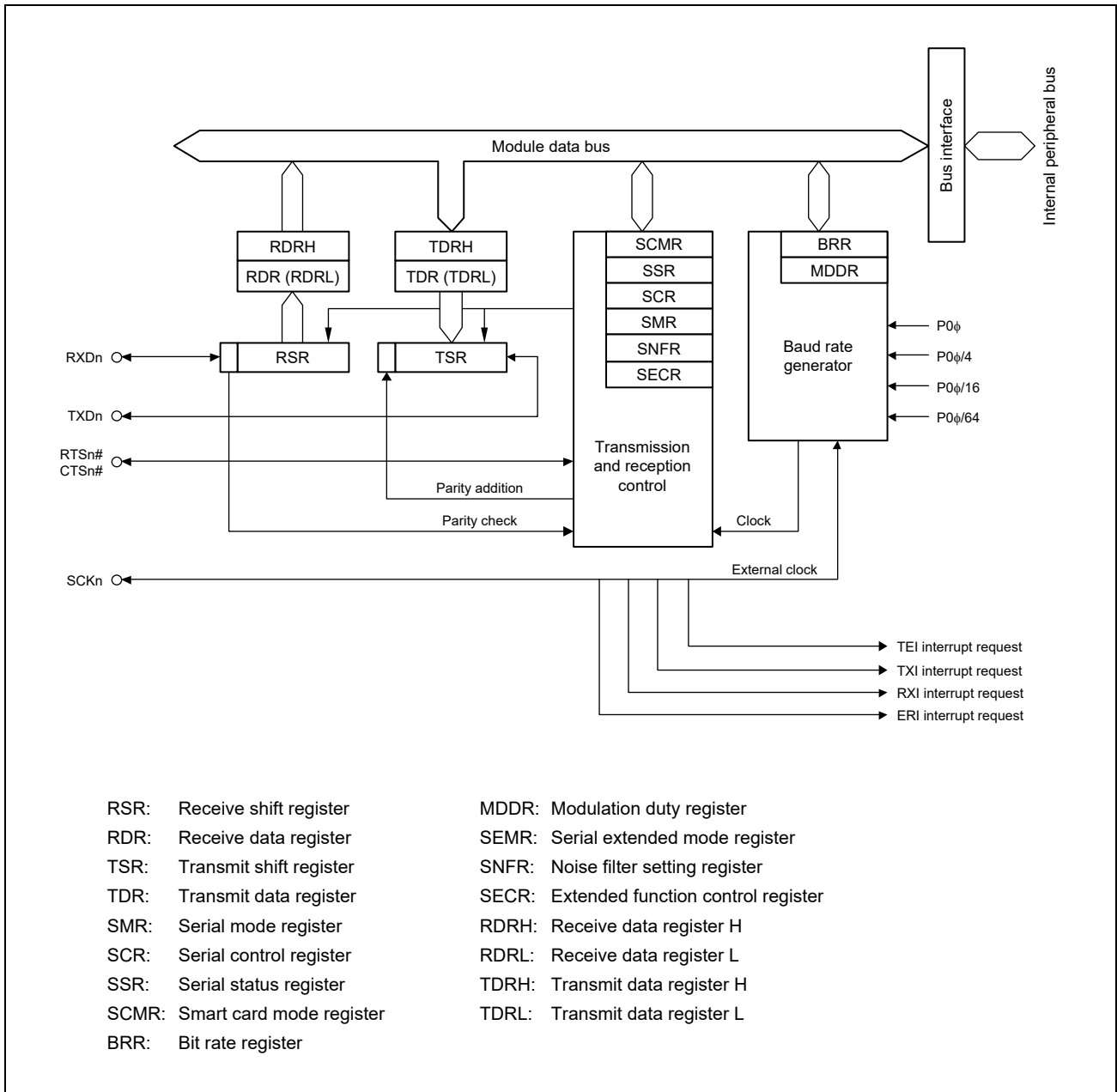

Figure 23.1 Block Diagram of SCIg (SCI0 and SCI1)

Table 23.2 lists the pin configuration of the SCIs for the individual modes.

Table 23.2 SCI Pin Configuration in Asynchronous Mode and Clock Synchronous Mode

Channel	Pin Name	I/O	Function
SCI0	SCI0_SCK	I/O	SCI0 clock input/output
	SCI0_RXD	Input	SCI0 receive data input
	SCI0_TXD	Output	SCI0 transmit data output
	SCI0_CTS#/RTS#	I/O	SCI0 transfer start control input/output
SCI1	SCI1_SCK	I/O	SCI1 clock input/output
	SCI1_RXD	Input	SCI1 receive data input
	SCI1_TXD	Output	SCI1 transmit data output
	SCI1_CTS#/RTS#	I/O	SCI1 transfer start control input/output

23.2 Register Descriptions

Table 23.3 Register configuration

BASE Address (AX45MP Address Space): (ch0) H'0_1004_D000 (ch1) H'0_1004_D400

Channel	Register Name	Abbreviation	R/W	Initial Value	Address	Access Size
0	Serial Mode Register	SMR	R/W	H'00	BASE(ch0) + H'0000	8
	Bit Rate Register	BRR	R/W	H'FF	BASE(ch0) + H'0001	8
	Serial Control Register	SCR	R/W	H'00	BASE(ch0) + H'0002	8
	Transmit Data Register	TDR	R/W	H'FF	BASE(ch0) + H'0003	8
	Serial Status Register	SSR	R/W*1	H'84	BASE(ch0) + H'0004	8
	Receive Data Register	RDR	R	H'00	BASE(ch0) + H'0005	8
	Smart Card Mode Register	SCMR	R/W*1	H'F2	BASE(ch0) + H'0006	8
	Serial Extended Mode Register	SEMR	R	H'00	BASE(ch0) + H'0007	8
	Noise Filter Setting Register	SNFR	R	H'00	BASE(ch0) + H'0008	8
	Extended Function Control Register	SECR	R/W	H'00	BASE(ch0) + H'000D	8
	Transmit Data Register H	TDRH	R/W	H'FF	BASE(ch0) + H'000E	8
	Transmit Data Register L	TDRL	R/W	H'FF	BASE(ch0) + H'000F	8
	Transmit Data Register HL	TDRHL	R/W	H'FFFF	BASE(ch0) + H'000E	16
	Receive Data Register H	RDRH	R	H'00	BASE(ch0) + H'0010	8
	Receive Data Register L	RDRL	R	H'00	BASE(ch0) + H'0011	8
	Receive Data Register HL	RDRHL	R	H'0000	BASE(ch0) + H'0010	16
Modulation Duty Register	MDDR	R/W	H'FF	BASE(ch0) + H'0012	8	
1	Serial Mode Register	SMR	R/W	H'00	BASE(ch1) + H'0000	8
	Bit Rate Register	BRR	R/W	H'FF	BASE(ch1) + H'0001	8
	Serial Control Register	SCR	R/W	H'00	BASE(ch1) + H'0002	8
	Transmit Data Register	TDR	R/W	H'FF	BASE(ch1) + H'0003	8
	Serial Status Register	SSR	R/W*1	H'84	BASE(ch1) + H'0004	8
	Receive Data Register	RDR	R	H'00	BASE(ch1) + H'0005	8
	Smart Card Mode Register	SCMR	R/W*1	H'F2	BASE(ch1) + H'0006	8
	Serial Extended Mode Register	SEMR	R	H'00	BASE(ch1) + H'0007	8
	Noise Filter Setting Register	SNFR	R	H'00	BASE(ch1) + H'0008	8
	Extended Function Control Register	SECR	R/W	H'00	BASE(ch1) + H'000D	8
	Transmit Data Register H	TDRH	R/W	H'FF	BASE(ch1) + H'000E	8
	Transmit Data Register L	TDRL	R/W	H'FF	BASE(ch1) + H'000F	8
	Transmit Data Register HL	TDRHL	R/W	H'FFFF	BASE(ch1) + H'000E	16
	Receive Data Register H	RDRH	R	H'00	BASE(ch1) + H'0010	8
	Receive Data Register L	RDRL	R	H'00	BASE(ch1) + H'0011	8
	Receive Data Register HL	RDRHL	R	H'0000	BASE(ch1) + H'0010	16
Modulation Duty Register	MDDR	R/W	H'FF	BASE(ch1) + H'0012	8	

Note 1. Partly, R only

23.2.1 Receive Shift Register (RSR)

RSR is a shift register which is used to receive serial data input from the RXDn pin and converts it into parallel data. When one frame of data has been received, it is automatically transferred to the RDR register.

The RSR register cannot be directly accessed by the CPU.

23.2.2 Receive Data Register (RDR)

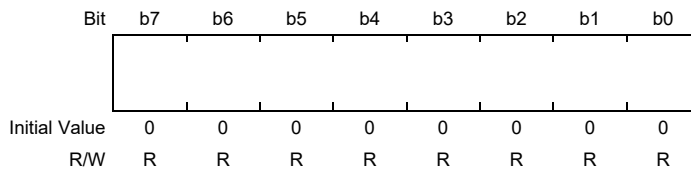

RDR is an 8-bit register that stores receive data.

When one frame of serial data has been received, the received serial data is transferred from RSR to RDR. Then the RSR register can receive the next data.

Since RSR and RDR function as a double buffer in this way, continuous receive operations can be performed.

Read RDR only once after a receive data full interrupt (RXI) has occurred. Note that if next one frame of data is received before reading receive data from RDR, an overrun error occurs.

RDR cannot be written to by the CPU.

23.2.3 Receive Data Register H, L, HL (RDRH, RDRL, RDRHL)

Receive Data Register H (RDRH)

Receive Data Register L (RDRL)

Receive Data Register HL (RDRHL)

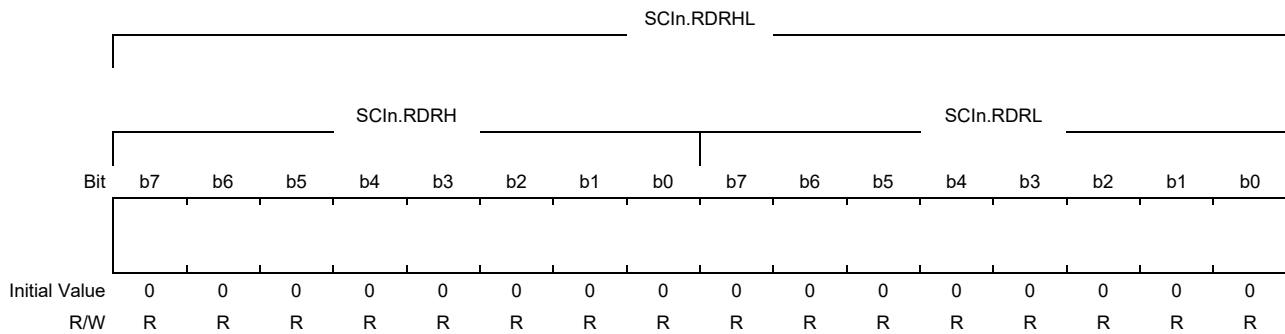

RDRH and RDRL are 8-bit registers that store receive data. Use these registers when asynchronous mode and 9-bit data length are selected.

RDRL is the shadow register of RDR; i.e. access to RDRL is equivalent to access to RDR.

After one frame of data is received, the received data is transferred from the RSR register to these registers, thus allowing the RSR register to receive the next data.

The RSR, RDRH and RDRL registers have a double-buffered construction to enable continuous reception.

Read RDRH and RDRL should be performed only once in the order from RDRH to RDRL when a receive data full interrupt (RXI) request is issued. Note that an overrun error occurs when the next frame of data is received before the received data has been read from RDRL.

The CPU cannot write to the RDRH and RDRL registers. Bits 0 to 7 in RDRH are fixed to 0. These bits are read as 0. The write value should be 0.

The RDRHL register can be accessed in 16-bit units.

23.2.4 Transmit Data Register (TDR)

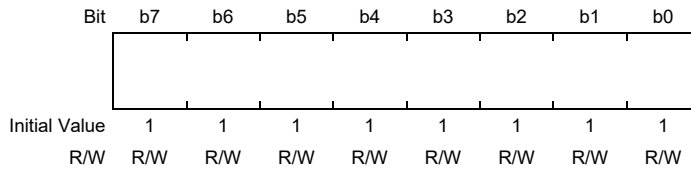

TDR is an 8-bit register that stores transmit data.

When the SCI detects that TSR is empty, it transfers the transmit data written in TDR to TSR and starts transmission. The double-buffered structures of TDR and TSR enable continuous serial transmission. If the next transmit data has already been written to TDR when one frame of data is transmitted, the SCI transfers the written data to TSR to continue transmission.

The CPU is able to read from or write to TDR at any time. Only write transmit data to TDR once after each instance of the transmit data empty interrupt (TXI).

23.2.5 Transmit Data Register H, L, HL (TDRH, TDRL, TDRHL)

Transmit Data Register H (TDRH)

Transmit Data Register L (TDRL)

Transmit Data Register HL (TDRHL)

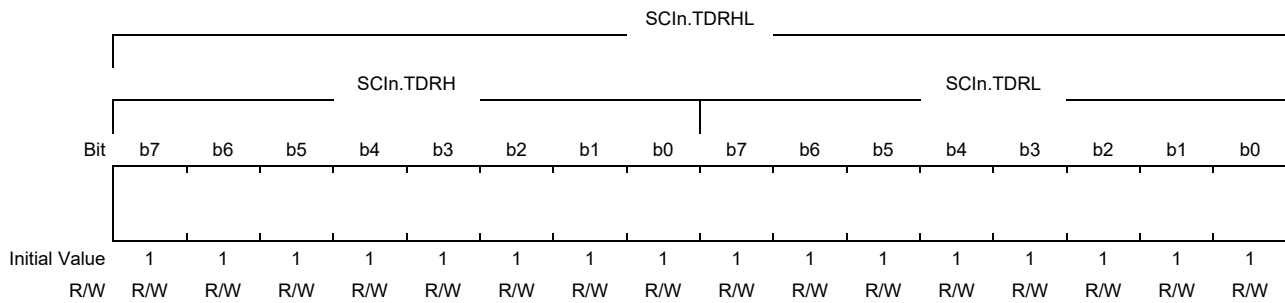

TDRH and TDRL are 8-bit registers that store transmit data. Use these registers when asynchronous mode and 9-bit data length are selected.

TDRL is the shadow register of TDR; i.e. access to TDRL is equivalent to access to TDR.

When empty space is detected in the TSR register, the transmit data stored in the TDRH and TDRL registers is transferred to TSR; i.e., transmitting is started.

The TSR, TDRH and TDRL registers have a double-buffered construction to realize continuous reception. When the next data to be transmitted is stored in TDRL after one frame of data has been transmitted, the transmitting operation is continued by transfer to the TSR register.

The CPU can read and write to the TDRH and TDRL registers. Bits 0 to 7 in RDRH are fixed to 1. These bits are read as 1. The write value should be 1.

Writing transmit data to the TDRH and TDRL registers should be performed only once in the order from TDRH to TDRL when a transmit data empty interrupt (TXI) request is issued.

The TDRHL register can be accessed in 16-bit units.

23.2.6 Transmit Shift Register (TSR)

TSR is a shift register that transmits serial data.

To perform serial data transmission, the SCI first automatically transfers transmit data from TDR to TSR, and then sends the data to the TXDn pin.

TSR cannot be directly accessed by the CPU.

23.2.7 Serial Mode Register (SMR)

NOTE

Some bits in SMR have different functions in smart card interface mode and non-smart card interface mode.

(1) Non-Smart Card Interface Mode (SCMR.SMIF = 0)

Bit	b7	b6	b5	b4	b3	b2	b1	b0
	CM	CHR	PE	PM	STOP	MP	CKS[1:0]	
Initial Value	0	0	0	0	0	0	0	0
R/W	R/W*4	R/W*4	R/W*4	R/W*4	R/W*4	R/W*4	R/W*4	R/W*4

Bit	Bit Name	Initial Value	R/W	Description
b1, b0	CKS[1:0]	00b	R/W*4	Clock Select b1 b0 0 0: P0 ϕ clock (n = 0)*1 0 1: P0 ϕ /4 clock (n = 1)*1 1 0: P0 ϕ /16 clock (n = 2)*1 1 1: P0 ϕ /64 clock (n = 3)*1
b2	MP	0b	R/W*4	Multi-Processor Mode (Valid only in asynchronous mode) 0: Multi-processor communications function is disabled 1: Multi-processor communications function is enabled
b3	STOP	0b	R/W*4	Stop Bit Length (Valid only in asynchronous mode) 0: 1 stop bit 1: 2 stop bits
b4	PM	0b	R/W*4	Parity Mode (Valid only when the PE bit is 1) 0: Selects even parity 1: Selects odd parity
b5	PE	0b	R/W*4	Parity Enable (Valid only in asynchronous mode) <ul style="list-style-type: none"> When transmitting <ul style="list-style-type: none"> 0: Parity bit addition is not performed 1: The parity bit is added When receiving <ul style="list-style-type: none"> 0: Parity bit checking is not performed 1: The parity bit is checked
b6	CHR	0b	R/W*4	Character Length (Valid only in asynchronous mode*2) Selects in combination with the SCMR.CHR1 bit. CHR1 CHR 0 0: Transmit/receive in 9-bit data length 0 1: Transmit/receive in 9-bit data length 1 0: Transmit/receive in 8-bit data length (initial value) 1 1: Transmit/receive in 7-bit data length*3
b7	CM	0b	R/W*4	Communications Mode 0: Asynchronous mode 1: Clock synchronous mode

Note 1. n is the decimal notation of the value of n in BRR (refer to **Section 23.2.11, Bit Rate Register (BRR)**).

Note 2. In other than asynchronous mode, this bit setting is invalid and a fixed data length of 8 bits is used.

Note 3. LSB first is fixed and the MSB (bit 7) in TDR is not transmitted in transmission.

Note 4. Writable only when TE in SCR = 0 and RE in SCR = 0 (both serial transmission and reception are disabled).

CKS[1:0] Bits (Clock Select)

These bits select the clock source for the on-chip baud rate generator.

For the relation between the settings of these bits and the baud rate, refer to **Section 23.2.11, Bit Rate Register (BRR)**.

MP Bit (Multi-Processor Mode)

Disables/enables the multi-processor communications function. The settings of the PE bit and PM bit are invalid in multi-processor mode.

STOP Bit (Stop Bit Length)

Selects the stop bit length in transmission.

In reception, only the first stop bit is checked regardless of this bit setting. If the second stop bit is 0, it is treated as the start bit of the next transmit frame.

PM Bit (Parity Mode)

Selects the parity mode (even or odd) for transmission and reception. The setting of the PM bit is invalid in multi-processor mode.

PE Bit (Parity Enable)

When this bit is set to 1, the parity bit is added to transmit data, and the parity bit is checked in reception. Irrespective of the setting of the PE bit, the parity bit is not added or checked in multi-processor format.

CHR Bit (Character Length)

Selects the data length for transmission and reception. Selects in combination with the CHR1 bit in SCMR.

In other than asynchronous mode, a fixed data length of 8 bits is used.

(2) Smart Card Interface Mode (SCMR.SMIF = 1)

Bit	b7	b6	b5	b4	b3	b2	b1	b0
	GM	BLK	PE	PM	BCP[1:0]		CKS[1:0]	
Initial Value	0	0	0	0	0	0	0	0
R/W	R/W*2	R/W*2	R/W*2	R/W*2	R/W*2	R/W*2	R/W*2	R/W*2

Bit	Bit Name	Initial Value	R/W	Description
b1, b0	CKS[1:0]	00b	R/W*2	Clock Select b1 b0 0 0: P0 ϕ clock (n = 0)*1 0 1: P0 ϕ /4 clock (n = 1)*1 1 0: P0 ϕ /16 clock (n = 2)*1 1 1: P0 ϕ /64 clock (n = 3)*1
b3, b2	BCP[1:0]	00b	R/W*2	Base Clock Pulse Selects the number of base clock cycles in combination with the SCMR.BCP2 bit. Table 23.4 lists the combinations of the SCMR.BCP2 bit and SMR.BCP[1:0] bits.
b4	PM	0b	R/W*2	Parity Mode (Valid only when the PE bit is 1) 0: Selects even parity 1: Selects odd parity
b5	PE	0b	R/W*2	Parity Enable When this bit is set to 1, a parity bit is added to transmit data, and the parity of received data is checked. Set this bit to 1 in smart card interface mode.
b6	BLK	0b	R/W*2	Block Transfer Mode 0: Normal mode operation 1: Block transfer mode operation
b7	GM	0b	R/W*2	GSM Mode 0: Normal mode operation 1: GSM mode operation

Note 1. n is the decimal notation of the value of n in BRR (refer to **Section 23.2.11, Bit Rate Register (BRR)**).

Note 2. Writable only when TE in SCR = 0 and RE in SCR = 0 (both serial transmission and reception are disabled).

CKS[1:0] Bits (Clock Select)

These bits select the clock source for the on-chip baud rate generator.

For the relationship between the settings of these bits and the baud rate, refer to **Section 23.2.11, Bit Rate Register (BRR)**.

BCP[1:0] Bits (Base Clock Pulse)

These bits select the number of base clock cycles in a 1-bit data transfer time in smart card interface mode. Set these bits in combination with the SCMR.BCP2 bit.

For details, refer to **Section 23.6.4, Receive Data Sampling Timing and Reception Margin**.

Table 23.4 Combinations of the SCMR.BCP2 Bit and SMR.BCP[1:0] Bits

SCMR.BCP2 Bit	SMR.BCP[1:0] Bits		Number of Base Clock Cycles for 1-Bit Transfer Period
0	0	0	93 clock cycles (S = 93)* ¹
0	0	1	128 clock cycles (S = 128)* ¹
0	1	0	186 clock cycles (S = 186)* ¹
0	1	1	512 clock cycles (S = 512)* ¹
1	0	0	32 clock cycles (S = 32)* ¹ (Initial Value)
1	0	1	64 clock cycles (S = 64)* ¹
1	1	0	372 clock cycles (S = 372)* ¹
1	1	1	256 clock cycles (S = 256)* ¹

Note 1. S is the value of Base Clock Cycles for 1-bit Period in BRR (refer to **Section 23.2.11, Bit Rate Register (BRR), Table 23.8 Base Clock Settings in Smart Card Interface Mode**).

PM Bit (Parity Mode)

Selects the parity mode for transmission and reception (even or odd).

For details on the usage of this bit in smart card interface mode, refer to **Section 23.6.2, Data Format (Except in Block Transfer Mode)**.

PE Bit (Parity Enable)

Set the PE bit to 1.

The parity bit is added to transmit data before transmission, and the parity bit is checked in reception.

BLK Bit (Block Transfer Mode)

Setting this bit to 1 allows block transfer mode operation.

For details, refer to **Section 23.6.3, Block Transfer Mode**.

GM Bit (GSM Mode)

Setting this bit to 1 allows GSM mode operation.

In GSM mode, the SSR.TEND flag set timing is put forward to 11.0 etu (elementary time unit = 1-bit transfer time) from the start and the clock output control function is appended. For details, refer to **Section 23.6.6, Serial Data Transmission (Except in Block Transfer Mode)** and **Section 23.6.8, Clock Output Control**.

23.2.8 Serial Control Register (SCR)

NOTE

Some bits in SCR have different functions in smart card interface mode and non-smart card interface mode.

(1) Non-Smart Card Interface Mode (SCMR.SMIF = 0)

Bit	b7	b6	b5	b4	b3	b2	b1	b0
	TIE	RIE	TE	RE	MPIE	TEIE	CKE[1:0]	
Initial Value	0	0	0	0	0	0	0	0
R/W	R/W	R/W	R/W*2	R/W*2	R/W	R/W	R/W*1	R/W*1

Bit	Bit Name	Initial Value	R/W	Description
b1, b0	CKE[1:0]	00b	R/W*1	Clock Enable <ul style="list-style-type: none"> • For SCI0 and SCI1 (Asynchronous mode) <ul style="list-style-type: none"> b1 b0 0 0: On-chip baud rate generator The SCKn pin functions as I/O port. 0 1: On-chip baud rate generator The clock with the same frequency as the bit rate is output from the SCKn pin. 1 x: External clock The clock with a frequency 16 times the bit rate should be input from the SCKn pin. Input a clock signal with a frequency eight times the bit rate when the SEMR.ABCS bit is 1. (Clock synchronous mode) <ul style="list-style-type: none"> b1 b0 0 x: Internal clock The SCKn pin functions as the clock output pin. 1 x: External clock The SCKn pin functions as the clock input pin.
b2	TEIE	0b	R/W	Transmit End Interrupt Enable <ul style="list-style-type: none"> 0: A TEI interrupt request is disabled 1: A TEI interrupt request is enabled
b3	MPIE	0b	R/W	Multi-Processor Interrupt Enable (Valid in asynchronous mode when SMR.MP = 1) <ul style="list-style-type: none"> 0: Normal reception 1: When the data with the multi-processor bit set to 0 is received, the data is not read, and setting the status flags ORER and FER in SSR to 1 is disabled. When the data with the multi-processor bit set to 1 is received, the MPIE bit is automatically cleared to 0, and normal reception is resumed.
b4	RE	0b	R/W*2	Receive Enable <ul style="list-style-type: none"> 0: Serial reception is disabled 1: Serial reception is enabled
b5	TE	0b	R/W*2	Transmit Enable <ul style="list-style-type: none"> 0: Serial transmission is disabled 1: Serial transmission is enabled
b6	RIE	0b	R/W	Receive Interrupt Enable <ul style="list-style-type: none"> 0: RXI and ERI interrupt requests are disabled 1: RXI and ERI interrupt requests are enabled

Bit	Bit Name	Initial Value	R/W	Description
b7	TIE	0b	R/W	Transmit Interrupt Enable 0: A TXI interrupt request is disabled 1: A TXI interrupt request is enabled

Remarks: x: Don't care

Note 1. Writable only when TE = 0 and RE = 0.

Note 2. 1 can be written only when TE = 0 and RE = 0, while the SMR.CM bit is 1. After setting TE or RE to 1, only 0 can be written to TE and RE. While the SMR.CM bit is 0 and the SIMR1.IICM bit is 0, writing is enabled under any condition.

CKE[1:0] Bits (Clock Enable)

These bits select the clock source and SCKn pin function.

The combination of the settings of these bits and of the SEMR.ACS0 bit sets the internal TMR clock.

TEIE Bit (Transmit End Interrupt Enable)

Enables or disables a TEI interrupt request.

A TEI interrupt request is disabled by setting the TEIE bit to 0.

MPIE Bit (Multi-Processor Interrupt Enable)

When this bit is set to 1 and the data with the multi-processor bit set to 0 is received, the data is not read and setting the status flags ORER and FER in SSR to 1 is disabled. When the data with the multi-processor bit set to 1 is received, the MPIE is automatically cleared to 0, and normal reception is resumed. For details, refer to **Section 23.4, Multi-Processor Communications Function**.

When the receive data includes the MPB bit is SSR set to 0, the receive data is not transferred from the RSR to the RDR, a receive error is not detected, and setting the flags ORER and FER to 1 is disabled.

When the receive data includes the MPB bit set to 1, the MPB bit is set to 1, the MPIE bit is automatically cleared to 0, the RXI and ERI interrupt requests are enabled (if the RIE bit in SCR is set to 1), and setting the flags ORER and FER to 1 is enabled.

MPIE should be set to 0 if multi-processor communications function is not to be used.

RE Bit (Receive Enable)

Enables or disables serial reception.

When this bit is set to 1, serial reception is started by detecting the start bit in asynchronous mode or the synchronous clock input in clock synchronous mode. Note that SMR should be set prior to setting the RE bit to 1 in order to designate the reception format.

Even if reception is halted by setting the RE bit to 0, the ORER, FER, and PER flags in SSR are not affected and the previous value is retained.

TE Bit (Transmit Enable)

Enables or disables serial transmission.

When this bit is set to 1, serial transmission is started by writing transmit data to TDR. Note that SMR should be set prior to setting the TE bit to 1 in order to designate the transmission format.

RIE Bit (Receive Interrupt Enable)

Enables or disables RXI and ERI interrupt requests.

An RXI interrupt request is disabled by setting the RIE bit to 0.

An ERI interrupt request can be canceled by reading 1 from the ORER, FER, or PER flag in SSR and then setting the flag to 0, or setting the RIE bit to 0.

(2) Smart Card Interface Mode (SCMR.SMIF = 1)

Bit	b7	b6	b5	b4	b3	b2	b1	b0
	TIE	RIE	TE	RE	MPIE	TEIE	CKE[1:0]	
Initial Value	0	0	0	0	0	0	0	0
R/W	R/W	R/W	R/W*2	R/W*2	R/W	R/W	R/W*1	R/W*1

Bit	Bit Name	Initial Value	R/W	Description
b1, b0	CKE[1:0]	00b	R/W*1	Clock Enable <ul style="list-style-type: none"> • When SMR.GM = 0 <ul style="list-style-type: none"> b1 b0 0 0: Output disabled (The SCKn pin is available for use as an I/O port according to the I/O port settings.) 0 1: Clock output 1 x: (Setting prohibited) • When SMR.GM = 1 <ul style="list-style-type: none"> b1 b0 0 0: Output fixed low x 1: Clock output 1 0: Output fixed high
b2	TEIE	0b	R/W	Transmit End Interrupt Enable This bit should be 0 in smart card interface mode.
b3	MPIE	0b	R/W	Multi-Processor Interrupt Enable This bit should be 0 in smart card interface mode.
b4	RE	0b	R/W*2	Receive Enable 0: Serial reception is disabled 1: Serial reception is enabled
b5	TE	0b	R/W*2	Transmit Enable 0: Serial transmission is disabled 1: Serial transmission is enabled
b6	RIE	0b	R/W	Receive Interrupt Enable 0: RXI and ERI interrupt requests are disabled 1: RXI and ERI interrupt requests are enabled
b7	TIE	0b	R/W	Transmit Interrupt Enable 0: A TXI interrupt request is disabled 1: A TXI interrupt request is enabled

Remarks: x: Don't care

Note 1. Writable only when TE = 0 and RE = 0.

Note 2. 1 can be written only when TE = 0 and RE = 0. After setting TE or RE to 1, only 0 can be written in TE and RE.

For details on interrupt requests, refer to **Section 23.8, Interrupt Sources**.

CKE[1:0] Bits (Clock Enable)

These bits control the clock output from the SCKn pin.

In GSM mode, clock output can be dynamically switched. For details, refer to **Section 23.6.8, Clock Output Control**.

TEIE Bit (Transmit End Interrupt Enable)

This bit should be 0 in smart card interface mode.

MPIE Bit (Multi-Processor Interrupt Enable)

This bit should be 0 in smart card interface mode.

RE Bit (Receive Enable)

Enables or disables serial reception.

When this bit is set to 1, serial reception is started by detecting the start bit. Note that SMR should be set prior to setting the RE bit to 1 in order to designate the reception format.

Even if reception is halted by setting the RE bit to 0, the ORER, FER, and PER flags in SSR are not affected and the previous value is retained.

TE Bit (Transmit Enable)

Enables or disables serial transmission.

When this bit is set to 1, serial transmission is started by writing transmit data to TDR. Note that SMR should be set prior to setting the TE bit to 1 in order to designate the transmission format.

RIE Bit (Receive Interrupt Enable)

Enables or disables RXI and ERI interrupt requests.

An RXI interrupt request is disabled by setting the RIE bit to 0.

An ERI interrupt request can be canceled by reading 1 from the ORER, FER, or PER flag in SSR and then setting the flag to 0, or setting the RIE bit to 0.

23.2.9 Serial Status Register (SSR)

Some bits in SSR have different functions in smart card interface mode and non-smart card interface mode.

(1) Non-Smart Card Interface Mode (SCMR.SMIF = 0)

Bit	b7	b6	b5	b4	b3	b2	b1	b0
	TDRE	RDRF	ORER	FER	PER	TEND	MPB	MPBT
Initial Value	1	0	0	0	0	1	0	0
R/W	R/(W)*2	R/(W)*2	R/(W)*1	R/(W)*1	R/(W)*1	R	R	R/W

Bit	Bit Name	Initial Value	R/W	Description
b0	MPBT	0b	R/W	Multi-Processor Bit Transfer Sets the multi-processor bit for adding to the transmission frame 0: Data transmission cycles 1: ID transmission cycles
b1	MPB	0b	R	Multi-Processor Value of the multi-processor bit in the reception frame 0: Data transmission cycles 1: ID transmission cycles
b2	TEND	1b	R	Transmit End Flag 0: A character is being transmitted. 1: Character transfer has been completed.
b3	PER	0b	R/(W) *1	Parity Error Flag 0: No parity error occurred 1: A parity error has occurred
b4	FER	0b	R/(W) *1	Framing Error Flag 0: No framing error occurred 1: A framing error has occurred
b5	ORER	0b	R/(W) *1	Overrun Error Flag 0: No overrun error occurred 1: An overrun error has occurred
b6	RDRF	0b	R/(W) *2	Receive Data Full Flag 0: When data is transferred from RDR 1: When data has been received normally, and transferred from RSR to RDR
b7	TDRE	1b	R/(W) *2	Transmit Data Empty Flag 0: When data is transferred to TDR 1: When data is transferred from TDR to TSR

Note 1. Only 0 can be written to this bit, to clear the flag.

Note 2. Write 1 when writing is necessary.

MPB Bit (Multi-Processor)

Holds the value of the multi-processor bit in the reception frame. This bit does not change when the SCR.RE bit is 0.

TEND Flag (Transmit End Flag)

Indicates completion of transmission.

[Setting conditions]

- When the SCR.TE bit is set to 0 (serial transmission is disabled)
When the SCR.TE bit is changed from 0 to 1, the TEND flag is not affected and retains the value 1.
- When the TDR register is not updated at the time of transmission of the tail-end bit of a character being transmitted

[Clearing condition]

- When transmit data are written to the TDR register while the SCR.TE bit is 1

PER Flag (Parity Error Flag)

Indicates that a parity error has occurred during reception in asynchronous mode and the reception ends abnormally.

[Setting condition]

- When a parity error is detected during reception
Although receive data when the parity error occurs is transferred to RDR, no RXI interrupt request occurs. Note that when the PER flag is being set to 1, the subsequent receive data is not transferred to RDR.

[Clearing condition]

- When 0 is written to PER after reading PER = 1
Even when the SCR.RE bit is set to 0 (serial reception is disabled), the PER flag is not affected and retains its previous value.

FER Flag (Framing Error Flag)

Indicates that a framing error has occurred during reception in asynchronous mode and the reception ends abnormally.

[Setting condition]

- When the stop bit is 0
In 2-stop-bit mode, only the first stop bit is checked whether it is 1 but the second stop bit is not checked. Note that although receive data when the framing error occurs is transferred to RDR, no RXI interrupt request occurs. In addition, when the FER flag is being set to 1, the subsequent receive data is not transferred to RDR.

[Clearing condition]

- When 0 is written to FER after reading FER = 1
Even when the SCR.RE bit is set to 0, the FER flag is not affected and retains its previous value.

ORER Flag (Overrun Error Flag)

Indicates that an overrun error has occurred during reception and the reception ends abnormally.

[Setting condition]

- When the next data is received before receive data is read from RDR
In RDR, receive data prior to an overrun error occurrence is retained, but data received after the overrun error occurrence is lost. When the ORER flag is set to 1, subsequent serial reception cannot be performed. Note that, in clock synchronous mode, serial transmission also cannot continue.

[Clearing condition]

- When 0 is written to ORER after reading ORER = 1
Even when the SCR.RE bit is set to 0, the ORER flag is not affected and retains its previous value.

RDRF Flag (Receive Data Full Flag)

Indicates whether RDR has received data.

[Setting condition]

- When data has been received normally, and transferred from RSR to RDR

[Clearing condition]

- When data is transferred from RDR

TDRE Flag (Transmit Data Empty Flag)

Indicates whether TDR has data to be transmitted.

[Setting condition]

- When data is transferred from TDR to TSR

[Clearing condition]

- When data is transferred to TDR

(2) Smart Card Interface Mode (SCMR.SMIF = 1)

Bit	b7	b6	b5	b4	b3	b2	b1	b0
	TDRE	RDRF	ORER	ERS	PER	TEND	MPB	MPBT
Initial Value	1	0	0	0	0	1	0	0
R/W	R/(W)* ²	R/(W)* ²	R/(W)* ¹	R/(W)* ¹	R/(W)* ¹	R	R	R/W

Bit	Bit Name	Initial Value	R/W	Description
b0	MPBT	0b	R/W	Multi-Processor Bit Transfer This bit should be set to 0 in smart card interface mode.
b1	MPB	0b	R	Multi-Processor This bit is not used in smart card interface mode. It should be set to 0.
b2	TEND	1b	R	Transmit End Flag 0: A character is being transmitted. 1: Character transfer has been completed.
b3	PER	0b	R/(W) ^{*1}	Parity Error Flag 0: No parity error occurred 1: A parity error has occurred
b4	ERS	0b	R/(W) ^{*1}	Error Signal Status Flag 0: Low error signal not responded 1: Low error signal responded
b5	ORER	0b	R/(W) ^{*1}	Overrun Error Flag 0: No overrun error occurred 1: An overrun error has occurred
b6	RDRF	0b	R/(W) ^{*2}	Receive Data Full Flag 0: When data is transferred from RDR 1: When data has been received normally, and transferred from RSR to RDR
b7	TDRE	1b	R/(W) ^{*2}	Transmit Data Empty Flag 0: When data is transferred to TDR 1: When data is transferred from TDR to TSR

Note 1. Only 0 can be written to this bit, to clear the flag.

Note 2. Write 1 when writing is necessary.

TEND Flag (Transmit End Flag)

With no error signal from the receiving side, this bit is set to 1 when further data for transfer is ready to be transferred to the TDR register.

[Setting conditions]

- When the SCR.TE bit = 0 (serial transmission is disabled)
When the SCR.TE bit is changed from 0 to 1, the TEND flag is not affected and retains the value 1.
- When a specified period has elapsed after the latest transmission of 1 byte, the ERS flag is 0, and the TDR register is not updated
The set timing is determined by register settings as listed below.
When SMR.GM = 0 and SMR.BLK = 0, 12.5 etu after the start of transmission
When SMR.GM = 0 and SMR.BLK = 1, 11.5 etu after the start of transmission
When SMR.GM = 1 and SMR.BLK = 0, 11.0 etu after the start of transmission
When SMR.GM = 1 and SMR.BLK = 1, 11.0 etu after the start of transmission

[Clearing condition]

- When transmit data are written to the TDR register while the SCR.TE bit is 1

PER Flag (Parity Error Flag)

Indicates that a parity error has occurred during reception in asynchronous mode and the reception ends abnormally.

[Setting condition]

- When a parity error is detected during reception
Although receive data when the parity error occurs is transferred to RDR, no RXI interrupt request occurs. Note that when the PER flag is being set to 1, the subsequent receive data is not transferred to RDR.

[Clearing condition]

- When 0 is written to PER after reading PER = 1
Even when the SCR.RE bit is set to 0 (serial reception is disabled), the PER flag is not affected and retains its previous value.

ERS Flag (Error Signal Status Flag)

[Setting condition]

- When a low error signal is sampled

[Clearing condition]

- When 0 is written to ERS after reading ERS = 1
Even when the SCR.RE bit is set to 0, the ERS flag is not affected and retains its previous value.

ORER Flag (Overrun Error Flag)

Indicates that an overrun error has occurred during reception and the reception ends abnormally.

[Setting condition]

- When the next data is received before receive data is read from RDR
In RDR, the receive data prior to an overrun error occurrence is retained, but data received following the overrun error occurrence is lost. When the ORER flag is set to 1, subsequent serial reception cannot be performed.

[Clearing condition]

- When 0 is written to ORER after reading ORER = 1
Even when the SCR.RE bit is set to 0, the ORER flag is not affected and retains its previous value.

RDRF Flag (Receive Data Full Flag)

Indicates whether RDR has received data.

[Setting condition]

- When data has been received normally, and transferred from RSR to RDR

[Clearing condition]

- When data is transferred from RDR

TDRE Flag (Transmit Data Empty Flag)

Indicates whether TDR has data to be transmitted.

[Setting condition]

- When data is transferred from TDR to TSR

[Clearing condition]

- When data is transferred to TDR

23.2.10 Smart Card Mode Register (SCMR)

Bit	b7	b6	b5	b4	b3	b2	b1	b0
	BCP2	—	—	CHR1	SDIR	SINV	—	SMIF
Initial Value	1	1	1	1	0	0	1	0
R/W	R/W*1	R/W	R/W	R/W*1	R/W*1	R/W*1	R/W	R/W*1

Bit	Bit Name	Initial Value	R/W	Description										
b0	SMIF	0b	R/W*1	Smart Card Interface Mode Select 0: Non-smart card interface mode (Asynchronous mode, clock synchronous mode,) 1: Smart card interface mode										
b1	—	1b	R/W	Reserved This bit is read as 1. The write value should be 1.										
b2	SINV	0b	R/W*1	Transmitted/Received Data Invert 0: TDR contents are transmitted as they are. Receive data is stored as it is in RDR. 1: TDR contents are inverted before being transmitted. Receive data is stored in inverted form in RDR.										
b3	SDIR	0b	R/W*1	Transmitted/Received Data Transfer Direction This bit can be used in the following modes. <ul style="list-style-type: none"> • Smart card interface mode • Asynchronous mode (multi-processor mode) • Clock synchronous mode 0: Transfer with LSB first 1: Transfer with MSB first										
b4	CHR1	1b	R/W*1	Character Length 1 (Only valid in asynchronous mode)*2 Selects in combination with the SMR.CHR bit. <table border="1"> <thead> <tr> <th>CHR1</th> <th>CHR</th> </tr> </thead> <tbody> <tr> <td>0</td> <td>0: Transmit/receive in 9-bit data length</td> </tr> <tr> <td>0</td> <td>1: Transmit/receive in 9-bit data length</td> </tr> <tr> <td>1</td> <td>0: Transmit/receive in 8-bit data length (initial value)</td> </tr> <tr> <td>1</td> <td>1: Transmit/receive in 7-bit data length*3</td> </tr> </tbody> </table>	CHR1	CHR	0	0: Transmit/receive in 9-bit data length	0	1: Transmit/receive in 9-bit data length	1	0: Transmit/receive in 8-bit data length (initial value)	1	1: Transmit/receive in 7-bit data length*3
CHR1	CHR													
0	0: Transmit/receive in 9-bit data length													
0	1: Transmit/receive in 9-bit data length													
1	0: Transmit/receive in 8-bit data length (initial value)													
1	1: Transmit/receive in 7-bit data length*3													
b6, b5	—	1b	R/W	Reserved These bits are read as 1. The write value should be 1.										
b7	BCP2	1b	R/W*1	Base Clock Pulse 2 Selects the number of base clock cycles in combination with the SMR.BCP[1:0] bits. Table 23.5 lists the combinations of the SCMR.BCP2 bit and SMR.BCP[1:0] bits.										

Note 1. Writable only when TE in SCR = 0 and RE in SCR = 0 (both serial transmission and reception are disabled).

Note 2. The setting is invalid and a fixed data length of 8 bits is used in modes other than asynchronous mode.

Note 3. LSB first should be selected and the value of MSB (b7) in TDR cannot be transmitted.

SMIF Bit (Smart Card Interface Mode Select)

When this bit is set to 1, smart card interface mode is selected.

When this bit is set to 0, non-smart card interface mode, i.e., asynchronous mode (including multi-processor mode), clock synchronous mode is selected.

SINV Bit (Transmitted/Received Data Invert)

Inverts the transmit/receive data logic level. This bit does not affect the logic level of the parity bit. To invert the parity bit, invert the PM bit in SMR.

CHR1 bit (Character Length 1)

Selects the data length of transmit/receive data. Selects in combination with the CHR bit in SMR.

A fixed data length of 8 bits is used in modes other than asynchronous mode.

BCP2 Bit (Base Clock Pulse 2)

Selects the number of base clock cycles in a 1-bit data transfer time in smart card interface mode. Set this bit in combination with the SMR.BCP[1:0] bits.

Table 23.5 Combinations of the SCMR.BCP2 Bit and SMR.BCP[1:0] Bits

SCMR.BCP2 Bit	SMR.BCP[1:0] Bits		Number of Base Clock Cycles for 1-Bit Transfer Period
0	0	0	93 clock cycles (S = 93)* ¹
0	0	1	128 clock cycles (S = 128)* ¹
0	1	0	186 clock cycles (S = 186)* ¹
0	1	1	512 clock cycles (S = 512)* ¹
1	0	0	32 clock cycles (S = 32)* ¹ (Initial Value)
1	0	1	64 clock cycles (S = 64)* ¹
1	1	0	372 clock cycles (S = 372)* ¹
1	1	1	256 clock cycles (S = 256)* ¹

Note 1. S is the value of Base Clock Cycles for 1-bit Period BRR (refer to **Section 23.2.11, Bit Rate Register (BRR), Table 23.8 Base Clock Settings in Smart Card Interface Mode**).

23.2.11 Bit Rate Register (BRR)

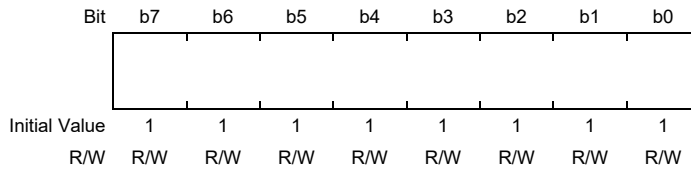

BRR is an 8-bit register that adjusts the bit rate.

As each SCI channel has independent baud rate generator control, different bit rates can be set for each. **Table 23.6** shows the relationship between the setting (N) in the BRR and the bit rate (B) for normal asynchronous mode, multi-processor communication, clock synchronous mode, and smart card interface mode.

The initial value of BRR is H'FF.

BRR can be read from by the CPU, but it can be written to only when the TE and RE bits in SCR are 0.

Table 23.6 Relationship between N Setting in BRR and Bit Rate B

Mode	SEMR	Setting	BRR Setting	Error
	BGDM Bit	ABCS Bit		
Asynchronous or multi-processor communication	0	0	$N = \frac{P0\phi \times 10^6}{64 \times 2^{2n-1} \times B} - 1$	$\text{Error (\%)} = \left\{ \frac{P0\phi \times 10^6}{B \times 64 \times 2^{2n-1} \times (N+1)} - 1 \right\} \times 100$
	0	1	$N = \frac{P0\phi \times 10^6}{32 \times 2^{2n-1} \times B} - 1$	$\text{Error (\%)} = \left\{ \frac{P0\phi \times 10^6}{B \times 32 \times 2^{2n-1} \times (N+1)} - 1 \right\} \times 100$
	1	0		
	1	1	$N = \frac{P0\phi \times 10^6}{16 \times 2^{2n-1} \times B} - 1$	$\text{Error (\%)} = \left\{ \frac{P0\phi \times 10^6}{B \times 16 \times 2^{2n-1} \times (N+1)} - 1 \right\} \times 100$
Clock synchronous			$N = \frac{P0\phi \times 10^6}{8 \times 2^{2n-1} \times B} - 1$	
Smart card interface			$N = \frac{P0\phi \times 10^6}{S \times 2^{2n+1} \times B} - 1$	$\text{Error (\%)} = \left\{ \frac{P0\phi \times 10^6}{B \times S \times 2^{2n+1} \times (N+1)} - 1 \right\} \times 100$

Remarks: B: Bit rate (bps)

N: BRR setting for on-chip baud rate generator ($0 \leq N \leq 255$)

P0φ: Operating frequency (MHz)

n and S: Determined by the settings of the SMR and SCMR registers as listed in the table below.

Table 23.7 Clock Source Settings

SMR.CKS[1:0] Bit Setting	Clock Source	n
0 0	P0 ϕ clock	0
0 1	P0 ϕ /4 clock	1
1 0	P0 ϕ /16 clock	2
1 1	P0 ϕ /64 clock	3

Table 23.8 Base Clock Settings in Smart Card Interface Mode

SCMR.BCP2 Bit Setting	SMR.BCP[1:0] Bit Setting	Base Clock Cycles for 1-bit Period	S
0	0 0	93 clock cycles	93
0	0 1	128 clock cycles	128
0	1 0	186 clock cycles	186
0	1 1	512 clock cycles	512
1	0 0	32 clock cycles	32
1	0 1	64 clock cycles	64
1	1 0	372 clock cycles	372
1	1 1	256 clock cycles	256

Table 23.9 lists examples of N settings in BRR in normal asynchronous mode. **Table 23.10** lists the maximum bit rate settable for each operating frequency. Examples of BRR (N) settings in clock synchronous mode are listed in **Table 23.12**. Examples of BRR (N) settings in smart card interface mode are listed in **Table 23.14**. In smart card interface mode, the number of base clock cycles S in a 1-bit data transfer time can be selected. For details, refer to **Section 23.6.4, Receive Data Sampling Timing and Reception Margin**. **Table 23.11** and **Table 23.13** list the maximum bit rates with external clock input.

When either the asynchronous mode base clock select bit (ABCS) or the baud rate generator double-speed mode select bit (BGDM) in the serial extended mode register (SEMR) is set to 1 in asynchronous mode, the bit rate becomes twice that listed in **Table 23.9**. When both of those registers are set to 1, the bit rate becomes four times the listed value.

Table 23.9 Examples of BRR Settings for Various Bit Rates (Asynchronous Mode)

Bit Rate (bps)	Operating Frequency P0 ϕ (MHz)		
	100		
	n	N	Error (%)
110	—	—	—
150	—	—	—
300	3	162	-0.15
600	3	80	0.47
1200	2	162	-0.15
2400	2	80	0.47
4800	1	162	-0.15
9600	1	80	0.47
19200	0	162	-0.15
31250	0	99	0.00
38400	0	80	0.47

Note: This is an example when the ABCS and BGDM bits in SEMR are 0.
 When either the ABCS bit or BGDM bit is set to 1, the bit rate doubles.
 When both ABCS and BGDM bits in SEMR are set to 1, the bit rate increases four times.

Table 23.10 Maximum Bit Rate for Each Operating Frequency (Asynchronous Mode)

P0 ϕ (MHz)	SEMR Settings				Maximum Bit Rate (bps)
	BGDM Bit	ABCS Bit	n	N	
100	0	0	0	0	3125000
		1	0	0	6250000
	1	0	0	0	6250000
		1	0	0	12500000

Table 23.11 Maximum Bit Rate with External Clock Input (Asynchronous Mode)

P0 ϕ (MHz)	Maximum Bit Rate (bps)		
	External Input Clock (MHz)	SEMR.ABCS Bit = 0	SEMR.ABCS Bit = 1
100	25.000	1562500	3125000

Table 23.12 BRR Settings for Various Bit Rates (Clock Synchronous Mode)

Bit Rate (bps)	Operating Frequency P0 ϕ (MHz)	
	100	
	n	N
110	—	—
250	—	—
500	—	—
1 k	—	—
2.5 k	3	155
5 k	3	77
10 k	2	155
25 k	1	249
50 k	1	124
100 k	0	249
250 k	0	99
500 k	0	49
1 M	0	24
2.5 M	0	9
5 M	0	4
7.5 M	0	2

Note: Continuous transmission or reception is impossible. After transmitting or receiving one frame of data, there is an interval of a 1-bit period before starting transmitting or receiving the next frame of data. The output of the synchronization clock is stopped for a 1-bit period. For this reason, it takes 9 bits worth of time to transfer one frame (8 bits) of data, and the average transfer rate is 8/9 times the bit rate.

Remarks: Space: Setting prohibited.

—: Can be set, but an error will occur.

Table 23.13 Maximum Bit Rate with External Clock Input (Clock Synchronous Mode)

P0 ϕ (MHz)	External Input Clock (MHz)	Maximum Bit Rate (Mbps)
100	16.6667	16.6667

Table 23.14 BRR Settings for Various Bit Rates (Smart Card Interface Mode, n = 0, S = 372)

Bit Rate (bps)	P0 ϕ (MHz)	n	N	Error (%)
9600	100	0	13	0.01

Table 23.15 Maximum Bit Rate for Each Operating Frequency (Smart Card Interface Mode, S = 32)

P0 ϕ (MHz)	Maximum Bit Rate (bps)	n	N
100.00	1562500	0	0

Table 23.16 Maximum Bit Rate for Each Operating Frequency (Smart Card Interface Mode, S = 372)

P0 ϕ (MHz)	Maximum Bit Rate (bps)	n	N
100.00	134409	0	0

23.2.12 Modulation Duty Register (MDDR)

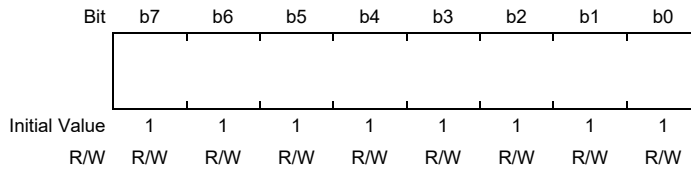

MDDR corrects the bit rate adjusted by the BRR register.

When the BRME bit in SEMR is set to 1, the bit rate generated by the on-chip baud rate generator is evenly corrected according to the settings of MDDR (M/256). The relationship between the MDDR setting (M) and the bit rate (B) is given in **Table 23.17**.

The initial value of MDDR is H'FF. Bit 7 in this register is fixed to 1.

The CPU can read the MDDR register, but this register is only writable when the TE and RE bits in SCR are 0.

Table 23.17 Relationship between MDDR Setting (M) and Bit Rate (B)
When Bit Rate Modulation Function is Used

Mode	SEMR	Setting	BRR Setting	Error
	BGDM Bit	ABCS Bit		
Asynchronous or multi-processor communication	0	0	$N = \frac{P0\phi \times 10^6}{64 \times 2^{2n-1} \times (256/M) \times B} - 1$	$\text{Error (\%)} = \left\{ \frac{P0\phi \times 10^6}{B \times 64 \times 2^{2n-1} \times (256M) \times (N+1)} - 1 \right\} \times 100$
	0	1	$N = \frac{P0\phi \times 10^6}{32 \times 2^{2n-1} \times (256/M) \times B} - 1$	$\text{Error (\%)} = \left\{ \frac{P0\phi \times 10^6}{B \times 32 \times 2^{2n-1} \times (256M) \times (N+1)} - 1 \right\} \times 100$
	1	0		
	1	1	$N = \frac{P0\phi \times 10^6}{16 \times 2^{2n-1} \times (256/M) \times B} - 1$	$\text{Error (\%)} = \left\{ \frac{P0\phi \times 10^6}{B \times 16 \times 2^{2n-1} \times (256M) \times (N+1)} - 1 \right\} \times 100$
Clock synchronous			$N = \frac{P0\phi \times 10^6}{8 \times 2^{2n-1} \times (256/M) \times B} - 1$	
Smart card interface			$N = \frac{P0\phi \times 10^6}{S \times 2^{2n-1} \times (256/M) \times B} - 1$	$\text{Error (\%)} = \left\{ \frac{P0\phi \times 10^6}{B \times S \times 2^{2n-1} \times (256M) \times (N+1)} - 1 \right\} \times 100$

Note: Do not use this function in clock synchronous mode with the highest speed setting (SMR.CKS[1:0] = 00b, SCR.CKE[1] = 0, and BRR = 0).

Remarks: B: Bit rate (bps)

M: MDDR setting (128 ≤ MDDR ≤ 256)

N: BRR setting for baud rate generator (0 ≤ N ≤ 255)

P0φ: Operating frequency (MHz)

n and S: Determined by the settings of the SMR and SCMR registers as listed in **Table 23.7** and **Table 23.8, Section 23.2.11, Bit Rate Register (BRR)**.

23.2.13 Serial Extended Mode Register (SEMR)

Bit	b7	b6	b5	b4	b3	b2	b1	b0
	RXDESEL	BGDM	NFEN	ABCS	—	BRME	—	ACS0
Initial Value	0	0	0	0	0	0	0	0
R/W	R/W*1	R/W	R/W*1	R/W*1	R/W	R/W	R/W	R/W*1

Bit	Bit Name	Initial Value	R/W	Description
b0	ACS0	0b	R/W*1	Asynchronous Mode Clock Source Select (Valid only in asynchronous mode) 0: External clock input 1: Reserved bit
b1	—	0b	R/W	Reserved This bit is read as 0. The write value should be 0.
b2	BRME	0b	R/W	Bit Rate Modulation Enable 0: Bit rate modulation function is disabled. 1: Bit rate modulation function is enabled.
b3	—	0b	R/W	Reserved This bit is read as 0. The write value should be 0.
b4	ABCS	0b	R/W*1	Asynchronous Mode Base Clock Select (Valid only in asynchronous mode) 0: Selects 16 base clock cycles for 1-bit period. 1: Selects 8 base clock cycles for 1-bit period.
b5	NFEN	0b	R/W*1	Digital Noise Filter Function Enable (In asynchronous mode) 0: Noise cancellation function for the RXDn input signal is disabled. 1: Noise cancellation function for the RXDn input signal is enabled.
b6	BGDM	0b	R/W	Baud Rate Generator Double-Speed Mode Select (Only valid the CKE[1] bit in SCR is 0 in asynchronous mode). 0: Baud rate generator outputs the clock with normal frequency. 1: Baud rate generator outputs the clock with doubled frequency.
b7	RXDESEL	0b	R/W*1	Asynchronous Start Bit Edge Detection Select (Valid only in asynchronous mode) 0: The low level on the RXDn pin is detected as the start bit. 1: A falling edge on the RXDn pin is detected as the start bit.

Note 1. Writable only when TE in SCR = 0 and RE in SCR = 0 (both serial transmission and reception are disabled).

SEMR selects the clock source for 1-bit period in asynchronous mode.

ACS0 Bit (Asynchronous Mode Clock Source Select)

Selects the clock source in the asynchronous mode.

The ACS0 bit is valid in asynchronous mode (CM bit in SMR = 0) and when an external clock input is selected (CKE[1:0] bits in SCR = 10b or 11b).

Set the ACS0 bit to 0 in other than asynchronous mode.

BRME bit (Bit Rate Modulation Enable)

Enables and disables the bit rate modulation function. The bit rate generated by on-chip baud rate generator is evenly corrected when this function is enabled.

NFEN Bit (Digital Noise Filter Function Enable)

This bit enables or disables the digital noise filter function.

When the function is enabled, noise cancellation is applied to the RXDn input signal in asynchronous mode. In any mode other than above, set the NFEN bit to 0 to disable the digital noise filter function.

When the function is disabled, input signals are transferred as is, as internal signals.

BGDM bit (Baud Rate Generator Double-Speed Mode Select)

Selects the cycle of output clock for the baud rate generator.

This bit is valid when the on-chip baud rate generator is selected as the clock source ($SCR.CKE[1] = 0$) in asynchronous mode ($SMR.CM = 0$). For the clock output from the baud rate generator, either normal or doubled frequency can be selected. The base clock is generated by the clock output from the baud rate generator. When the BGDM bit is set to 1, the base clock cycle is halved and the bit rate is doubled. Set this bit to 0 in modes other than asynchronous mode.

RXDESEL Bit (Asynchronous Start Bit Edge Detection Select)

Selects the detection method of the start bit for reception in asynchronous mode. When a break occurs, data receiving operation depends on the settings of this bit. Set this bit to 1 when reception should be stopped while a break occurs or when reception should be started without retaining the RXDn pin input at high level for the period of one data frame or longer after completion of the break.

Set this bit to 0 in modes other than asynchronous mode.

23.2.14 Noise Filter Setting Register (SNFR)

Bit	b7	b6	b5	b4	b3	b2	b1	b0
	—	—	—	—	—	NFCS[2:0]		
Initial Value	0	0	0	0	0	0	0	0
R/W	R/W	R/W	R/W	R/W	R/W	R/W* ¹	R/W* ¹	R/W* ¹

Bit	Bit Name	Initial Value	R/W	Description
b2 to b0	NFCS[2:0]	All 0	R/W* ¹	Noise Filter Clock Select In asynchronous mode, the standard setting for the base clock is as follows. b2 b0 0 0 0: The clock signal divided by 1 is used with the noise filter. Settings other than above are prohibited.
b7 to b3	—	All 0	R/W	Reserved These bits are read as 0. The write value should be 0.

Note 1. Writing to these bits is only possible when the RE and TE bits in the SCR are 0 (serial reception and transmission disabled).

NFCS[2:0] Bits (Noise Filter Clock Select)

These bits select the sampling clock for the digital noise filter. To use the noise filter in asynchronous mode, set these bits to 000b.

23.2.15 Extended function control register (SECR)

Bit	b7	b6	b5	b4	b3	b2	b1	b0
	—	—	—	—	—	—	CTSE	—
Initial Value	0	0	0	0	0	0	0	0
R/W	R/W	R/W	R/W	R/W	R/W	R/W	R/W* ¹	R/W

Bit	Bit Name	Initial Value	R/W	Description
b0	—	0b	R/W	Reserved This bit is read as 0. The write value should be 0.
b1	CTSE	0b	R/W* ¹	CTS Enable 0: CTS function is disabled (RTS output function is enabled). 1: CTS function is enabled.
B7 to b2	—	All 0	R/W	Reserved These bits are read as 0. The write value should be 0.

Note 1. Writing to the bit is only possible when the SCR.RE and SCR.TE bits are 0.

SECR is used to select the extension settings in asynchronous and clock synchronous modes.

CTSE Bit (CTS Enable)

Set this bit to 1 if the SSn# pin is to be used for inputting of the CTS control signal to control of transmission and reception. The RTS signal is output when this bit is set to 0. Set this bit to 0 in smart card interface mode. Do not set both the CTSE and SSE bits to enabled (even if this setting is made, operation is the same as that when these bits are set to 0).

23.3 Operation in Asynchronous Mode

Figure 23.2 shows the general format for asynchronous serial communications.

One frame consists of a start bit (low level), transmit/receive data, a parity bit, and stop bits (high level).

In asynchronous serial communications, the communications line is usually held in the mark state (high level).

The SCI monitors the communications line. When the SCI detects a low, it regards that as a start bit and starts serial communication.

Inside the SCI, the transmitter and receiver are independent units, enabling full-duplex communications. Both the transmitter and the receiver also have a double-buffered structure, so that data can be read or written during transmission or reception, enabling continuous data transmission and reception.

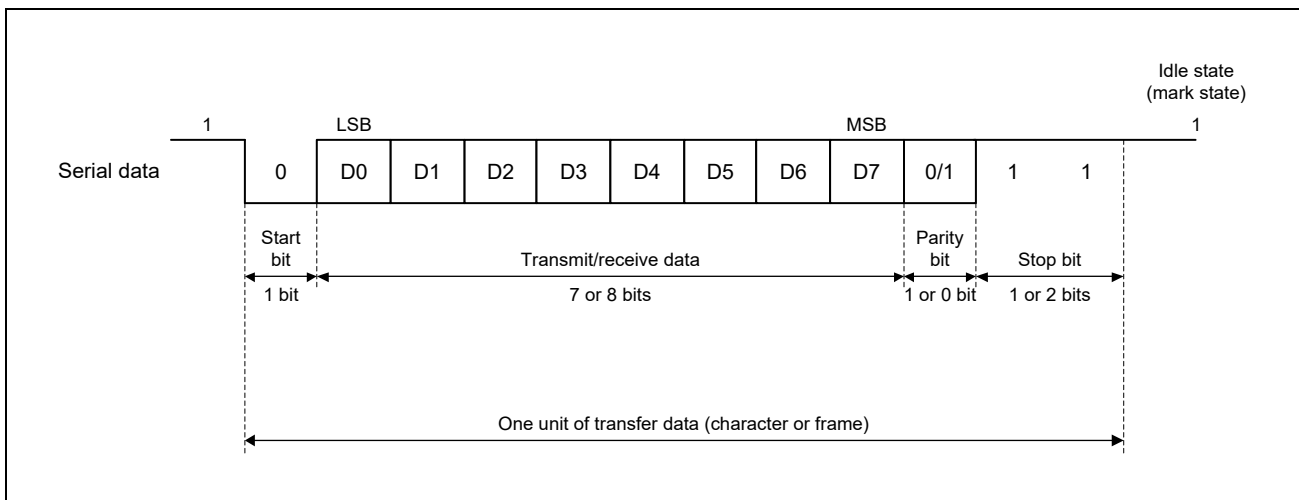

Figure 23.2 Data Format in Asynchronous Serial Communications (Example with 8-Bit Data, Parity, 2 Stop Bits)

23.3.1 Serial Data Transfer Format

Table 23.18 lists the serial data transfer formats that can be used in asynchronous mode.

Any of 18 transfer formats can be selected according to the SMR and SCMR setting. For details of multi-processor function, refer to **Section 23.4, Multi-Processor Communications Function**.

Table 23.18 Serial Transfer Formats (Asynchronous Mode)

SCMR Setting	SMR Setting				Serial Transfer Format and Frame Length																	
	CHR1	CHR	PE	MP	STOP	1	2	3	4	5	6	7	8	9	10	11	12	13				
0	0	0	0	0	0	S	9-bit data									STOP						
0	0	0	0	1	1	S	9-bit data									STOP	STOP					
0	0	1	0	0	0	S	9-bit data									P	STOP					
0	0	1	0	1	1	S	9-bit data									P	STOP	STOP				
1	0	0	0	0	0	S	8-bit data								STOP							
1	0	0	0	1	1	S	8-bit data								STOP	STOP						
1	0	1	0	0	0	S	8-bit data								P	STOP						
1	0	1	0	1	1	S	8-bit data								P	STOP	STOP					
1	1	0	0	0	0	S	7-bit data							STOP								
1	1	0	0	1	1	S	7-bit data							STOP	STOP							
1	1	1	0	0	0	S	7-bit data							P	STOP							
1	1	1	0	1	1	S	7-bit data							P	STOP	STOP						
0	0	—	1	0	0	S	9-bit data									MPB	STOP					
0	0	—	1	1	1	S	9-bit data									MPB	STOP	STOP				
1	0	—	1	0	0	S	8-bit data								MPB	STOP						
1	0	—	1	1	1	S	8-bit data								MPB	STOP	STOP					
1	1	—	1	0	0	S	7-bit data							MPB	STOP							
1	1	—	1	1	1	S	7-bit data							MPB	STOP	STOP						

Note: S: Start bit
 STOP: Stop bit
 P: Parity bit
 MPB: Multi-processor bit

23.3.2 Receive Data Sampling Timing and Reception Margin in Asynchronous Mode

In asynchronous mode, the SCI operates on a base clock with a frequency of 16 times*¹ the bit rate.

In reception, the SCI samples the falling edge of the start bit using the base clock, and performs internal synchronization. Since receive data is sampled at the rising edge of the 8th pulse*¹ of the base clock, data is latched at the middle of each bit, as shown in **Figure 23.3**. Thus the reception margin in asynchronous mode is determined by formula (1) below.

$$M = \left| \left(0.5 - \frac{1}{2N} \right) - (L - 0.5)F - \frac{|D - 0.5|}{N} (1 + F) \right| \times 100 [\%] \dots \text{Formula (1)}$$

M: Reception margin

N: Ratio of bit rate to clock (N = 16 when ABCS in SEMR = 0, N = 8 when ABCS in SEMR = 1)

D: Duty cycle of clock (D = 0.5 to 1.0)

L: Frame length (L = 9 to 13)

F: Absolute value of clock frequency deviation

Assuming values of F = 0 and D = 0.5 in formula (1), the reception margin is determined by the formula below.

$$M = \{ 0.5 - 1/(2 \times 16) \} \times 100 (\%) = 46.875\%$$

However, this is only the computed value, and a margin of 20% to 30% should be allowed in system design.

Note 1. This is an example when the ABCS bit in SEMR is 0. When the ABCS bit is 1, a frequency of 8 times the bit rate is used as a base clock and receive data is sampled at the rising edge of the 4th pulse of the base clock.

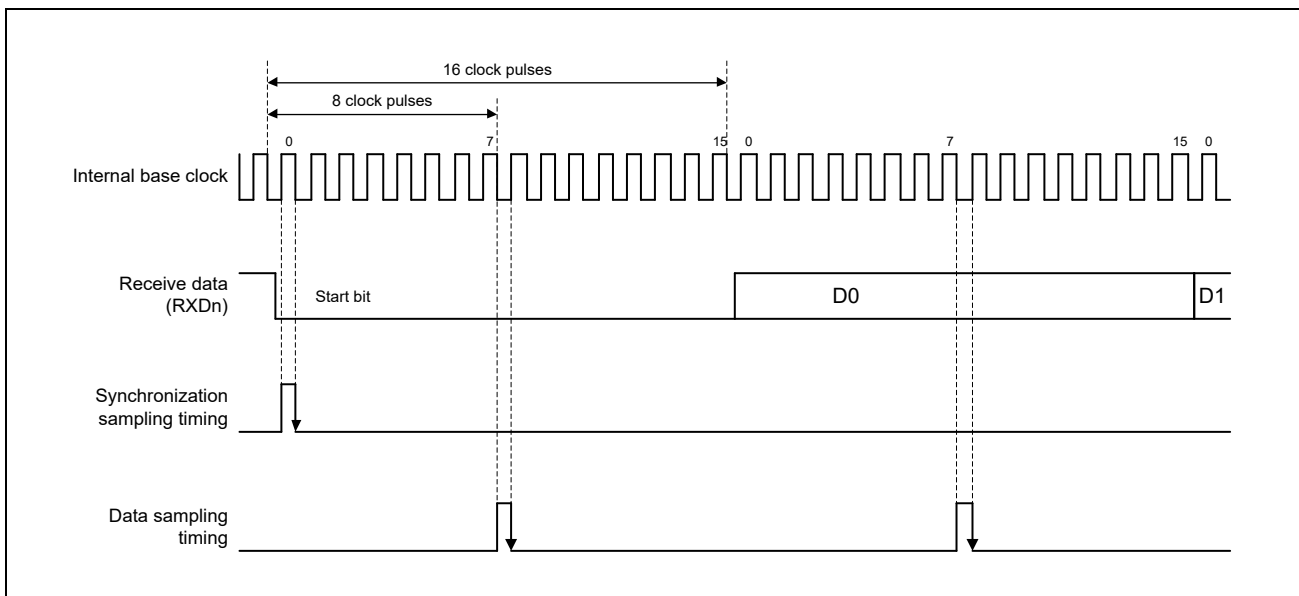

Figure 23.3 Receive Data Sampling Timing in Asynchronous Mode

23.3.3 Clock

Either an internal clock generated by the on-chip baud rate generator or an external clock input to the SCKn pin can be selected as the SCI's transfer clock, according to the setting of the CM bit in SMR and the CKE[1:0] bits in SCR. When an external clock is input to the SCKn pin, the clock frequency should be 16 times the bit rate (when ABCS in SEMR = 0) and 8 times the bit rate (when ABCS in SEMR = 1).

When the SCI is operated on an internal clock, the clock can be output from the SCKn pin. The frequency of the clock output in this case is equal to the bit rate, and the phase is such that the rising edge of the clock is in the middle of the transmit data, as shown in **Figure 23.4**.

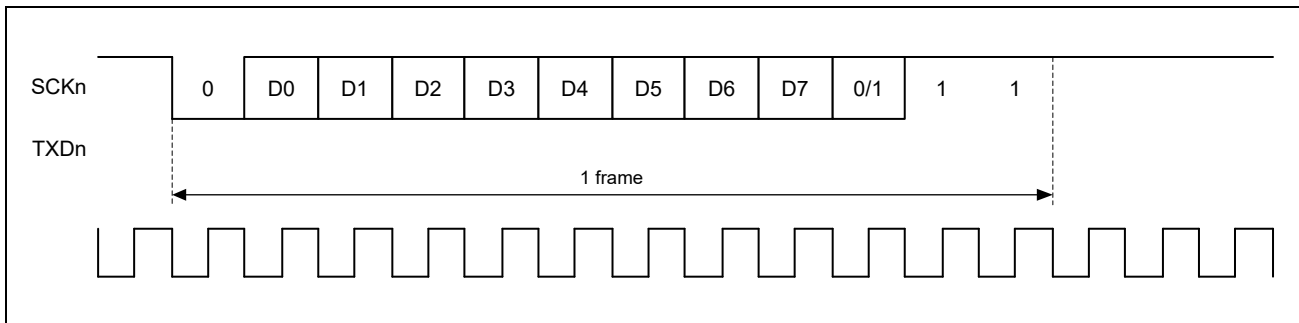

Figure 23.4 Phase Relationship between Output Clock and Transmit Data
(Asynchronous Mode: SMR.CHR = 0, PE = 1, MP = 0, STOP = 1)

23.3.4 Double-Speed Mode

The output clock frequency of the on-chip baud rate generator is doubled by setting the SEMR.BGDM bit to 1, enabling high-speed communication at a doubled bit rate. If the SEMR.ABCS bit is set to 1 under the above condition, the number of base clock cycles changes from 16 to 8, so the bit rate becomes four times faster than the initial state.

As shown by Formula (1) in **Section 23.3.2, Receive Data Sampling Timing and Reception Margin in Asynchronous Mode**, setting the SEMR.ABCS bit to 1 changes the number of cycles to 8, and the sampling interval becomes longer. This causes the reception margin to decrease. Therefore, setting the SEMR.BGDM bit to 1 and the SEMR.ABCS bit to 0 is recommended instead of setting the SEMR.BGDM bit to 0 and the SEMR.ABCS bit to 1 for high-speed operation at a doubled bit rate.

23.3.5 CTS and RTS Functions

The CTS function is the use of input on the CTSn# pin in transmission control. Setting the SECR.CTSE bit to 1 enables the CTS function. When the CTS function is enabled, placing the low level on the CTSn# pin causes transmission to start.

Applying the high level to the CTS# pin while transmission is in progress does not affect transmission of the current frame, which continues.

In the RTS function, by using the function of output on the RTSn# pin, a low level is output when reception becomes possible. Conditions for output of the low and high level are shown below.

[Conditions for low-level output]

Satisfaction of all conditions listed below

- The value of the RE bit in the SCR is 1
- Reception is not in progress
- There are no received data yet to be read
- The ORER, FER, and PER flags in the SSR are all 0

[Condition for high-level output]

- The conditions for low-level output have not been satisfied.

23.3.6 SCI Initialization (Asynchronous Mode)

Before transmitting and receiving data, start by writing the initial value H'00 to SCR and then continue through the procedure for SCI given in **Figure 23.5**. Whenever the operating mode or transfer format is changed, SCR must be initialized before the change is made.

When the external clock is used in asynchronous mode, ensure that the clock signal is supplied even during initialization. Note that setting the SCR.RE bit to 0 initializes neither the ORER, FER, and PER flags in SSR nor RDR, RDRH, and RDRL.

Moreover, note that switching the value of the SCR.TE bit from 1 to 0 or 0 to 1 while the SCR.TIE bit is 1 leads to the generation of a TXI interrupt request.

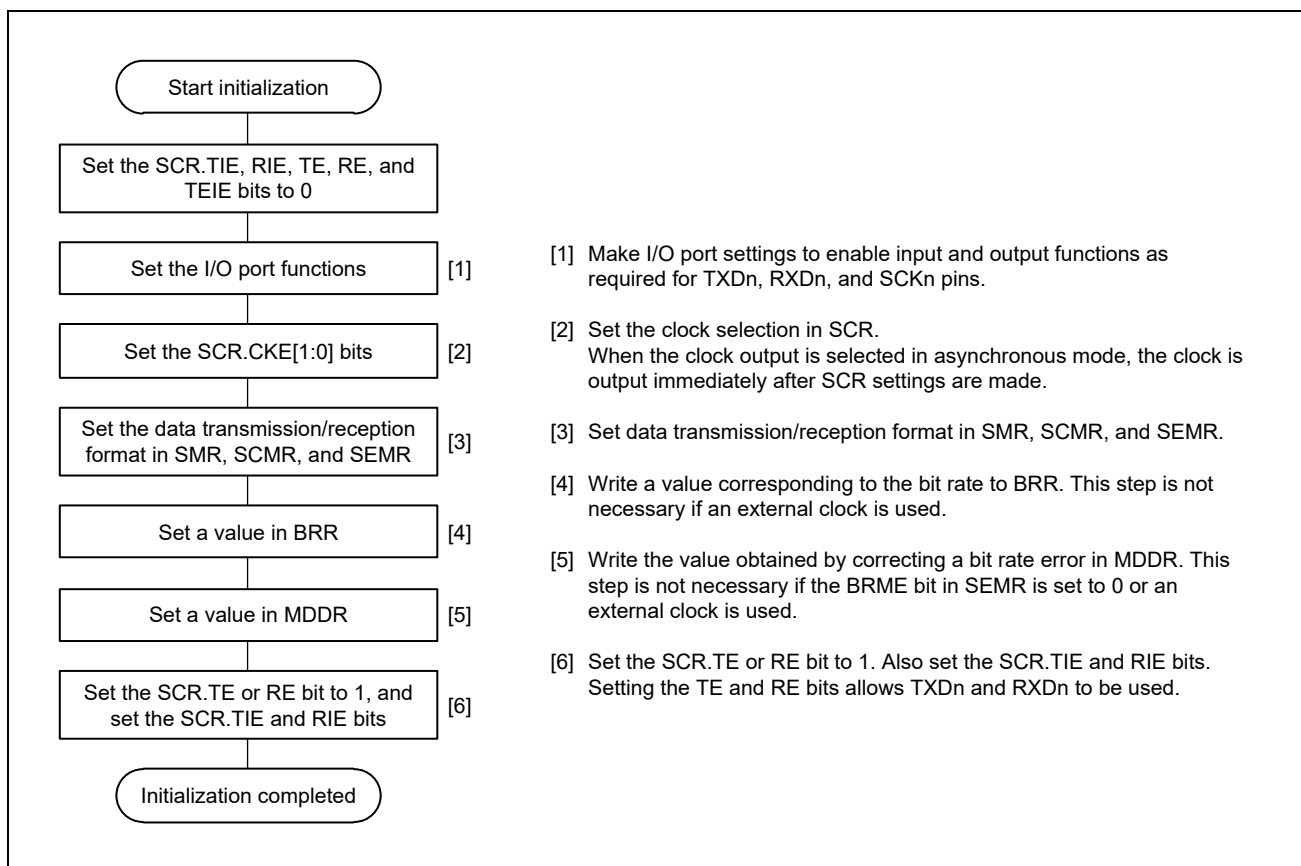

Figure 23.5 Sample SCI Initialization Flowchart (Asynchronous Mode)

23.3.7 Serial Data Transmission (Asynchronous Mode)

Figure 23.6 to **Figure 23.8** show an example of the operation for serial transmission in asynchronous mode. In serial transmission, the SCI operates as described below.

1. The SCI transfers data from TDR*¹ to TSR when data is written to TDR*¹ in the TXI interrupt handling routine. The TXI interrupt request at the beginning of transmission is generated when the TE bit in SCR is set to 1 after the TIE bit in SCR is set to 1 or when these 2 bits are set to 1 simultaneously by a single instruction.
2. Transmission starts after the CTSE bit in SECR is set to 0 (CTS function is disabled) and a low level on the CTSn# pin causes data transfer from TDR*¹ to TSR. If the TIE bit in SCR is 1 at this time, a TXI interrupt request is generated. Continuous transmission is obtainable by writing the next transmit data to TDR*¹ in the TXI interrupt handling routine before transmission of the current transmit data is completed. When TEI interrupt requests are in use, set the SCR.TIE bit to 0 (a TXI interrupt request is disabled) and the SCR.TEIE bit to 1 (a TEI interrupt request is enabled) after the last of the data to be transmitted are written to the TDR*^{1*2} from the handling routine for TXI requests.
3. Data is sent from the TXDn pin in the following order: start bit, transmit data, parity bit or multi-processor bit (may be omitted depending on the format), and stop bit.
4. The SCI checks for updating of (writing to) TDR*³ at the time of stop bit output.
5. When TDR*³ is updated, setting of the CTSE bit in SECR to 0 (CTS function is disabled) or a low level input on the CTSn# pin cause the next transfer of the next transmit data from TDR*¹ to TSR and sending of the stop bit, after which serial transmission of the next frame starts.
6. If TDR*³ is not updated, the TEND flag in SSR is set to 1, the stop bit is sent, and then the mark state is entered in which 1 is output. If the TEIE bit in SCR is 1 at this time, the TEND flag in SSR is set to 1 and a TEI interrupt request is generated.

Note 1. Write data not to TDR but to the TDRH and TDRL registers when 9-bit data length is selected.

Note 2. Write data in the order from TDRH to TDRL when 9-bit data length is selected.

Note 3. The SCI checks for updating of the TDRL register only and does not check for updating of the TDRH register when 9-bit data length is selected.

Figure 23.9 shows a sample flowchart for serial transmission in asynchronous mode.

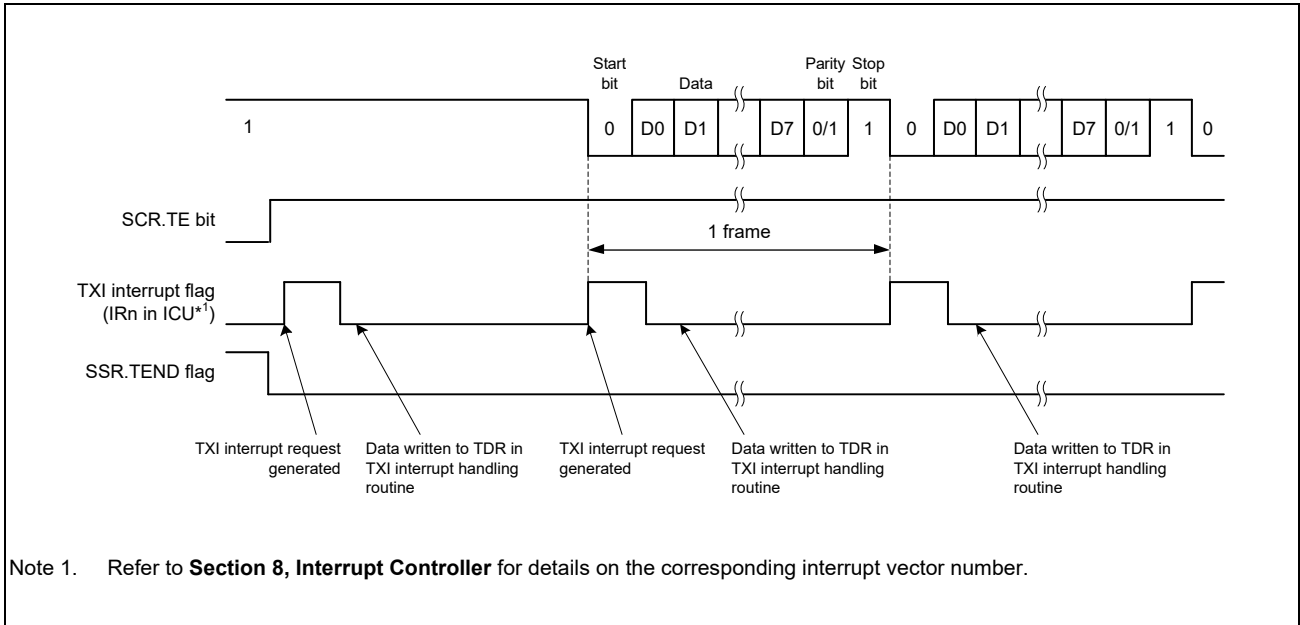

Figure 23.6 Example of Operation for Serial Transmission in Asynchronous Mode (1)
(with 8-Bit Data, Parity, 1 Stop Bit, CTS Function Not Used, at the Beginning of Transmission)

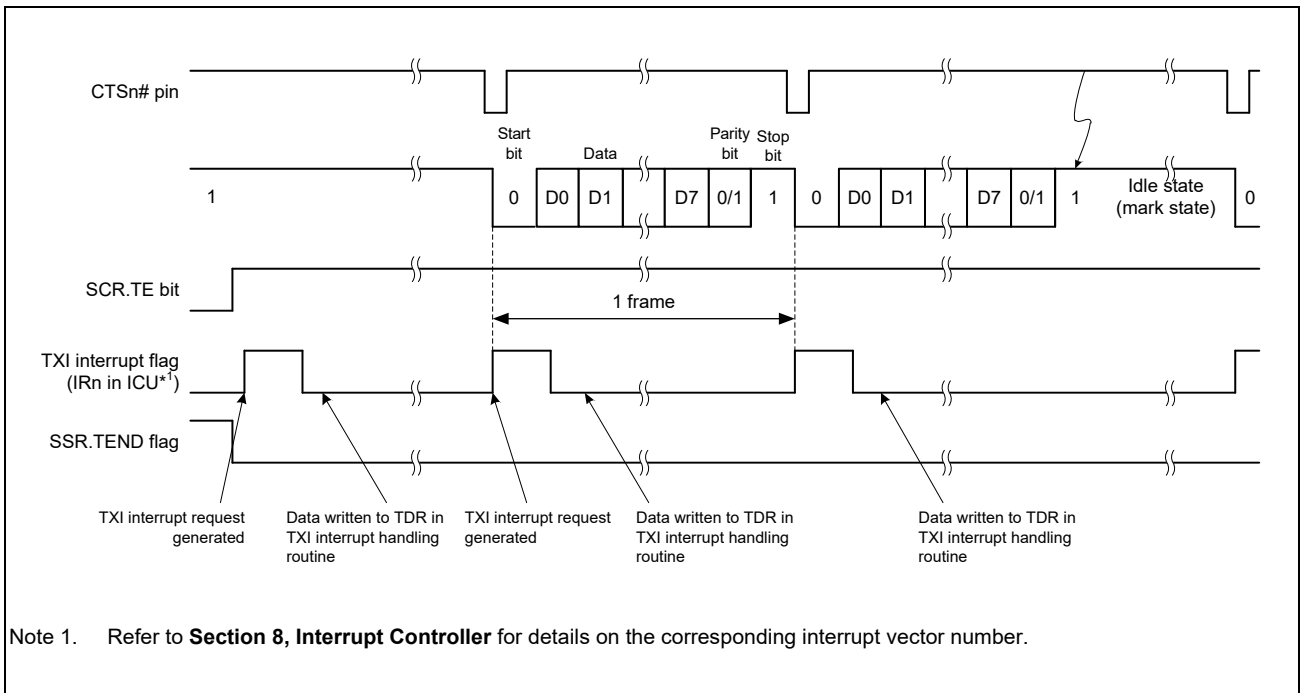

Figure 23.7 Example of Operation for Serial Transmission in Asynchronous Mode (2)
(with 8-Bit Data, Parity, 1 Stop Bit, CTS Function Used, at the Beginning of Transmission)

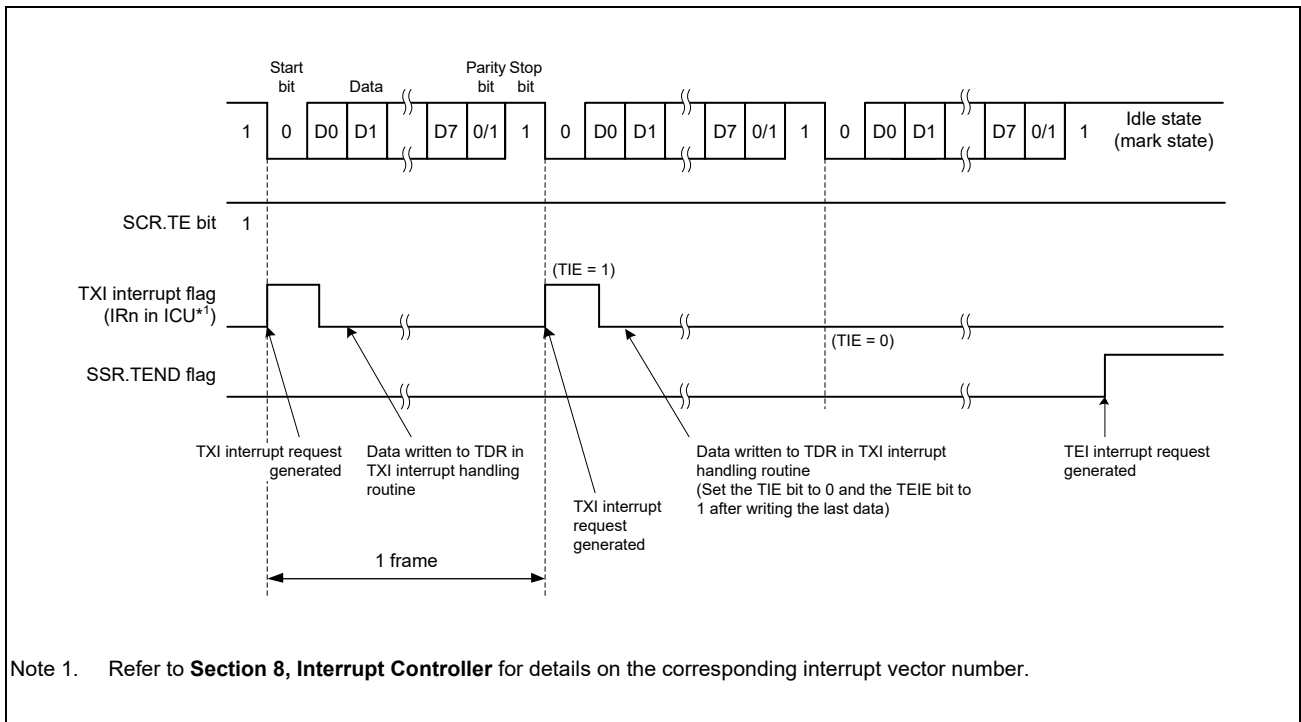

Figure 23.8 Example of Operation for Serial Transmission in Asynchronous Mode (3)
 (with 8-Bit Data, Parity, 1 Stop Bit, CTS Function Not Used, from the Middle of Transmission until Transmission Completion)

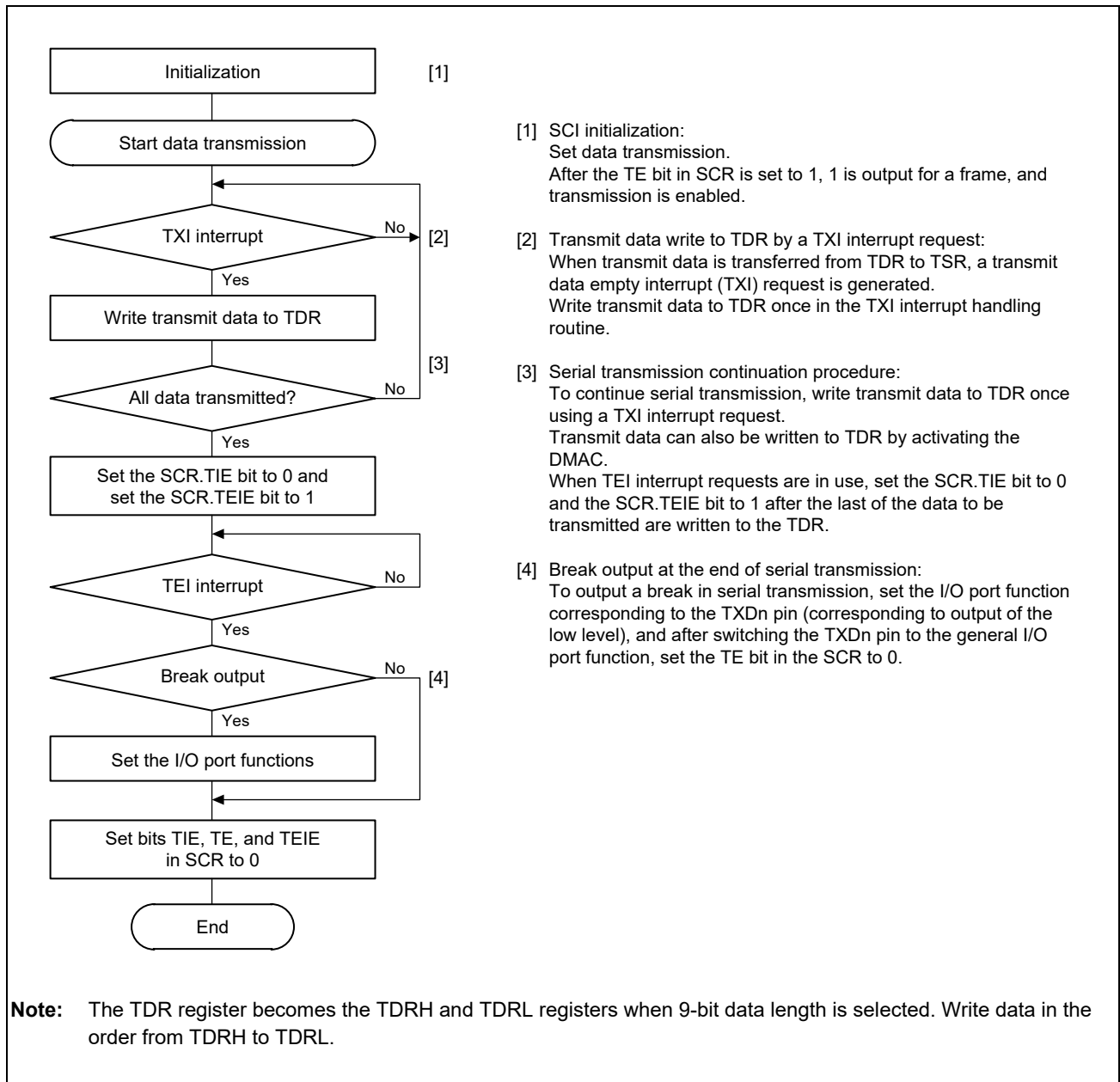

Figure 23.9 Example of Serial Transmission Flowchart in Asynchronous Mode

23.3.8 Serial Data Reception (Asynchronous Mode)

Figure 23.10 and **Figure 23.11** show an example of the operation for serial data reception in asynchronous mode. In serial data reception, the SCI operates as described below.

1. When the value of the RE bit in SCR becomes 1, the output signal on the RTSn# pin goes to the low level.
2. When the SCI monitors the communications line and detects a start bit, it performs internal synchronization, stores receive data in RSR, and checks the parity bit and stop bit.
3. If an overrun error occurs, the ORER flag in SSR is set to 1. If the RIE bit in SCR is 1 at this time, an ERI interrupt request is generated. Receive data is not transferred to RDR*¹.
4. If a parity error is detected, the PER bit in SSR is set to 1 and receive data is transferred to RDR*¹. If the RIE bit in SCR is 1 at this time, an ERI interrupt request is generated.
5. If a framing error (when the stop bit is 0) is detected, the FER bit in SSR is set to 1 and receive data is transferred to RDR*¹. If the RIE bit in SCR is 1 at this time, an ERI interrupt request is generated.
6. When reception finishes successfully, receive data is transferred to RDR*¹. If the RIE bit in SCR is 1 at this time, an RXI interrupt request is generated. Continuous reception is enabled by reading the receive data transferred to RDR*¹ in this RXI interrupt handling routine before reception of the next receive data is completed. Reading the received data that have been transferred to RDR*¹ causes the RTSn# pin to output the low level.

Note 1. Read data not in RDR but in the RDRH and RDRL registers when 9-bit data length is selected.

NOTE

The SCI checks for reading of the RDRL register only and does not check for reading of the RDRH register when 9-bit data length is selected.

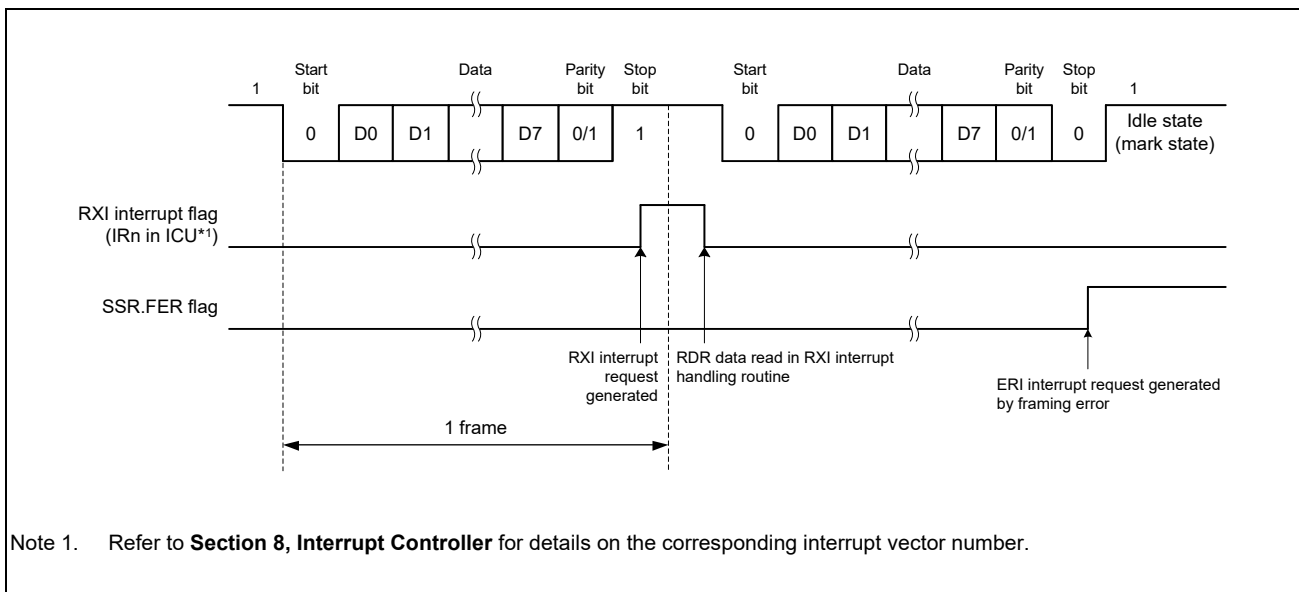

Figure 23.10 Example of SCI Operation for Serial Reception in Asynchronous Mode (1)
(When RTS Function is Not Used) (Example with 8-Bit Data, Parity, 1 Stop Bit)

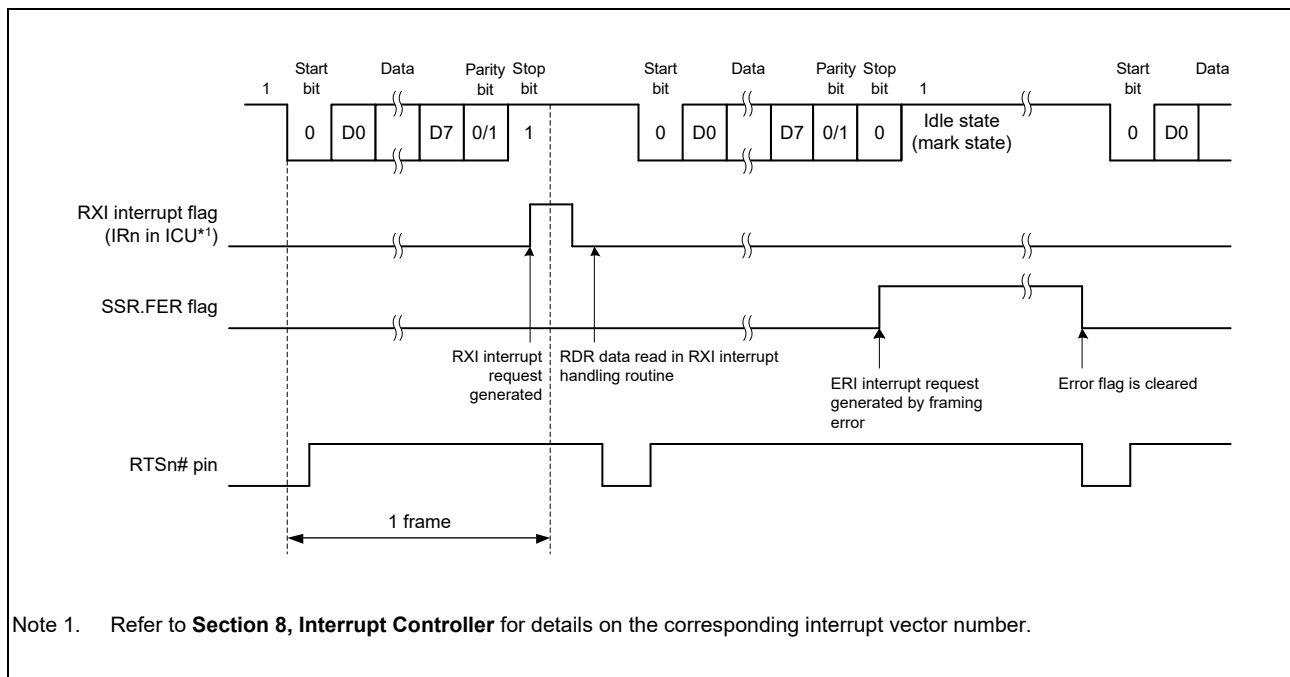

Figure 23.11 Example of SCI Operation for Serial Reception in Asynchronous Mode (2)
(When RTS Function is Used) (Example with 8-Bit Data, Parity, 1 Stop Bit)

Table 23.19 lists the states of the flags in the SSR status register and receive data handling when a receive error is detected.

If a receive error is detected, an ERI interrupt request is generated but an RXI interrupt request is not generated. Data reception cannot be resumed while the receive error flag is 1. Accordingly, set the ORER, FER, and PER bits to 0 before resuming reception. Moreover, be sure to read the RDR (or the RDRL) during overrun error processing. When a reception is forcibly terminated by setting the SCR.RE bit to 0 during operation, read the RDR (or the RDRL) register because received data which has not yet been read may be left in RDR (or the RDRL).

Figure 23.12 and **Figure 23.13** show samples of flowcharts for serial data reception.

Table 23.19 Flags in the SSR Status Register and Receive Data Handling

Flags in the SSR Status Register			Receive Data	Receive Error Type
ORER	FER	PER		
1	0	0	Lost	Overrun error
0	1	0	Transferred to RDR*1	Framing error
0	0	1	Transferred to RDR*1	Parity error
1	1	0	Lost	Overrun error + framing error
1	0	1	Lost	Overrun error + parity error
0	1	1	Transferred to RDR*1	Framing error + parity error
1	1	1	Lost	Overrun error + framing error + parity error

Note 1. Read data not in RDR but in the RDRH and RDRL registers when 9-bit data length is selected.

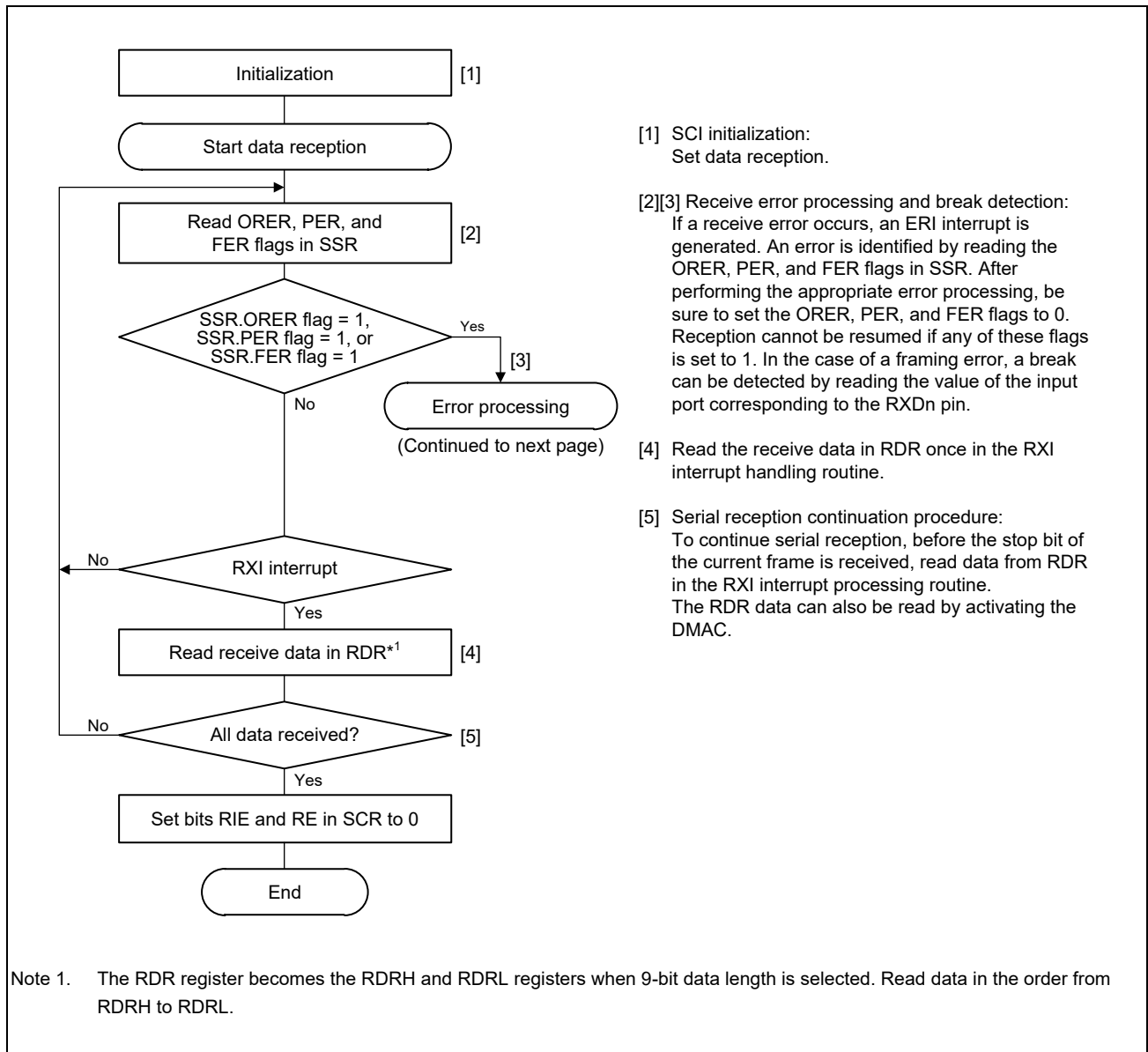

Figure 23.12 Example Flowchart of Serial Reception in Asynchronous Mode (1)

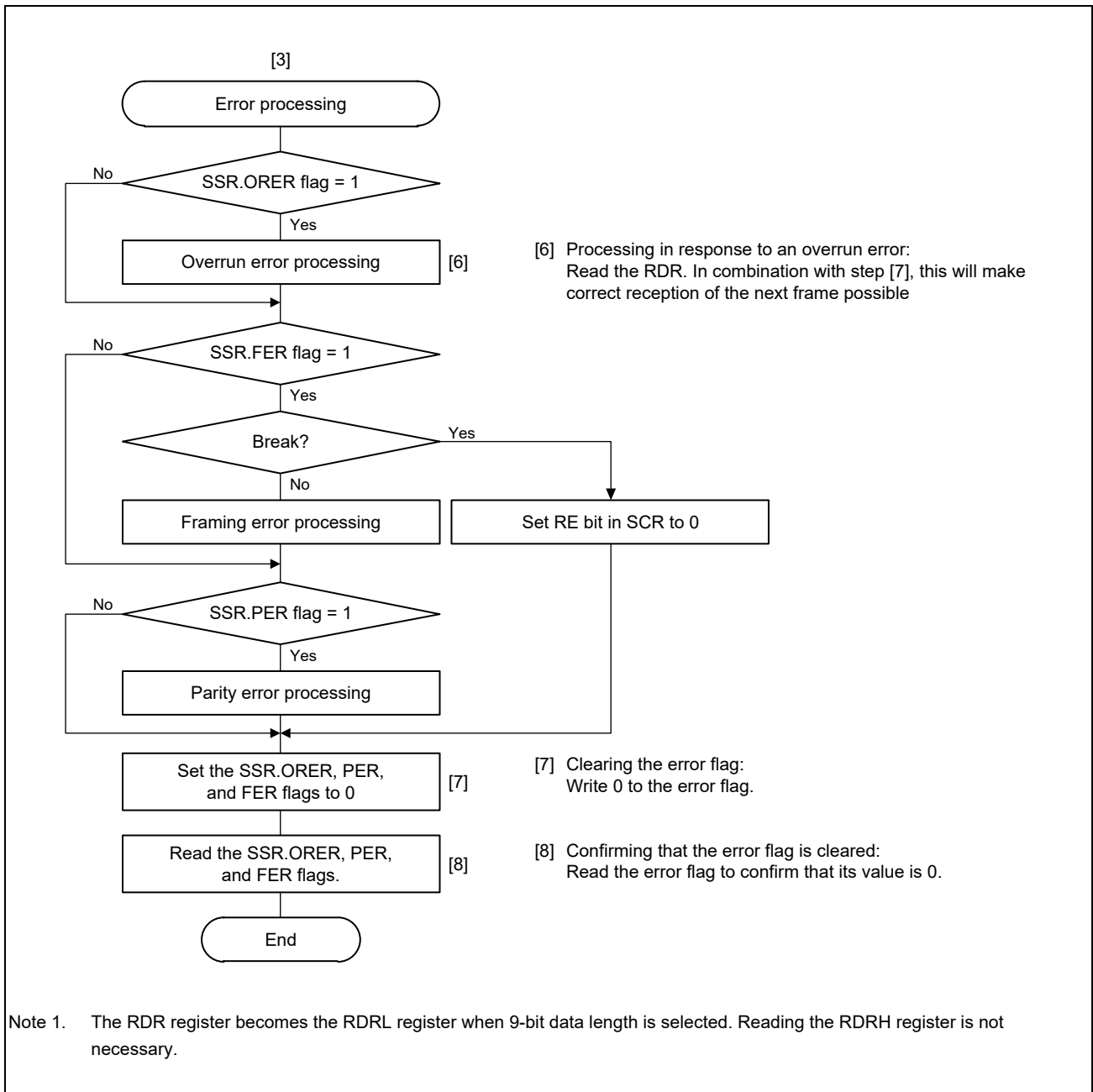

Figure 23.13 Example Flowchart of Serial Reception in Asynchronous Mode (2)

23.4 Multi-Processor Communications Function

Using the multi-processor communication functions enables to transmit and receive data by sharing a communication line between multiple processors by using asynchronous serial communication in which the multi-processor bit is added. In multi-processor communication, a unique ID code is allocated to each receiving station. Serial communication cycles consist of an ID transmission cycle to specify the receiving station and a data transmission cycle to transmit data to the specified receiving station. The multi-processor bit is used to distinguish between the ID transmission cycle and the data transmission cycle. When the multi-processor bit is set to 1, it indicates the ID transmission cycle and when the multi-processor bit is set to 0, it indicates the data transmission cycle. **Figure 23.14** shows an example of communication between processors by using a multi-processor format. First, a transmitting station transmits communication data in which the multi-processor bit set to 1 is added to the ID code of the receiving station. Next, the transmitting station transmits the communication data in which the multi-processor bit set to 0 is added to the transmit data. Upon receiving the communication data in which the multi-processor bit is set to 1, the receiving station compares the received ID with the ID of the receiving station itself and if the two match, receives the communication data that is subsequently transmitted. If the received ID does not match with the ID of the receiving station, the receiving station skips the communication data until again receiving the communication data in which the multi-processor bit is set to 1.

For supporting this function, the SCI provides the MPIE bit in SCR. When the MPIE bit is set to 1, transfer of receive data from the RSR to the RDR (the RDRH and RDRL registers when 9-bit data length is selected), detection of a receive error, and setting the respective status flags ORER and FER in SSR are disabled until reception of data in which the multi-processor bit is set to 1. Upon receiving a reception character in which the multi-processor bit is set to 1, the MPBT bit in SSR is set to 1 and the MPIE bit in SCR is automatically cleared, thus returning to a normal reception operation. During this time, an RXI interrupt is generated if the RIE bit in SCR is set.

When the multi-processor format is specified, specification of the parity bit is disabled. Apart from this, there is no difference from the operation in the normal asynchronous mode. A clock which is used for the multi-processor communication is also the same as the clock used in the normal asynchronous mode.

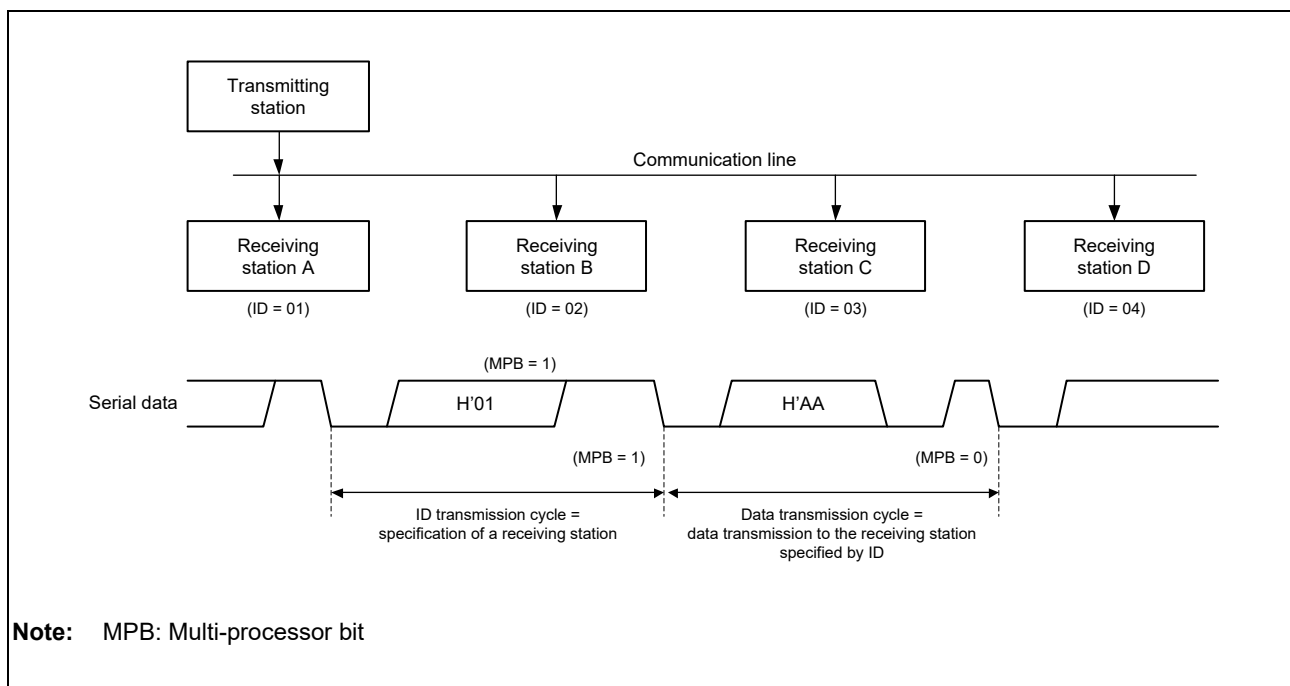

Figure 23.14 An Example of Communication using the Multi-Processor Format
(Example of Transmission of Data H'AA to Receiving Station A)

23.4.1 Multi-Processor Serial Data Transmission

Figure 23.15 is a sample flowchart of multi-processor data transmission. In the ID transmission cycle, the ID should be transmitted with the MPBT bit in SSR set to 1. In the data transmission cycle, the data should be transmitted with the MPBT bit set to 0. The other operations are the same as the operations in asynchronous mode.

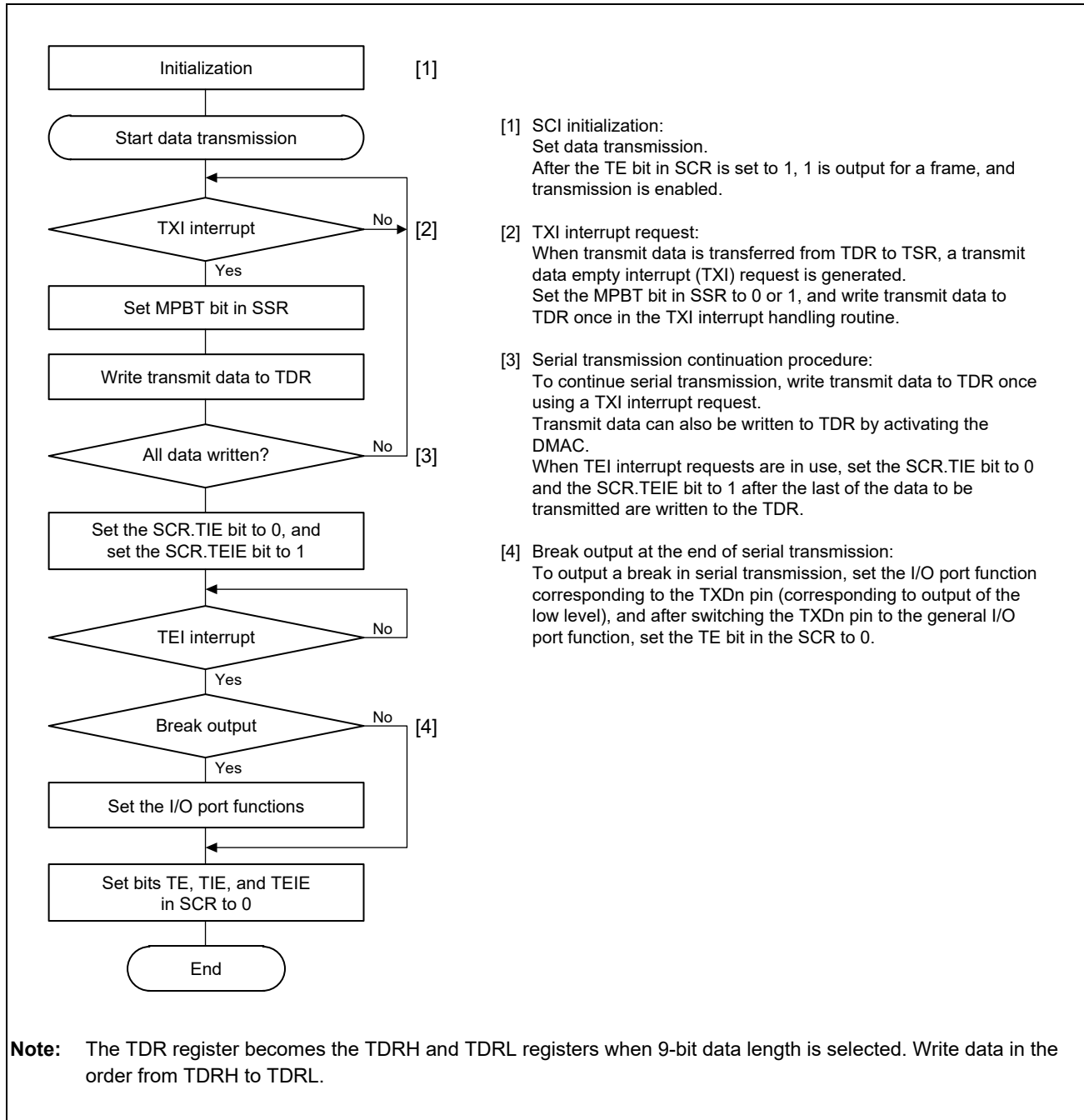

Figure 23.15 Example of Multi-Processor Serial Transmission Flowchart

23.4.2 Multi-Processor Serial Data Reception

Figure 23.17 and Figure 23.18 are sample flowcharts of multi-processor data reception. When the MPIE bit in SCR is set to 1, reading the communication data is skipped until reception of the communication data in which the multi-processor bit is set to 1. When the communication data in which the multi-processor bit is set to 1 is received, the received data is transferred to RDR (the RDRH and RDRL registers when 9-bit data length is selected). During this time, the RXI interrupt request is generated. The other operations are the same as the operations in asynchronous mode.

Figure 23.16 is the example of operation for reception.

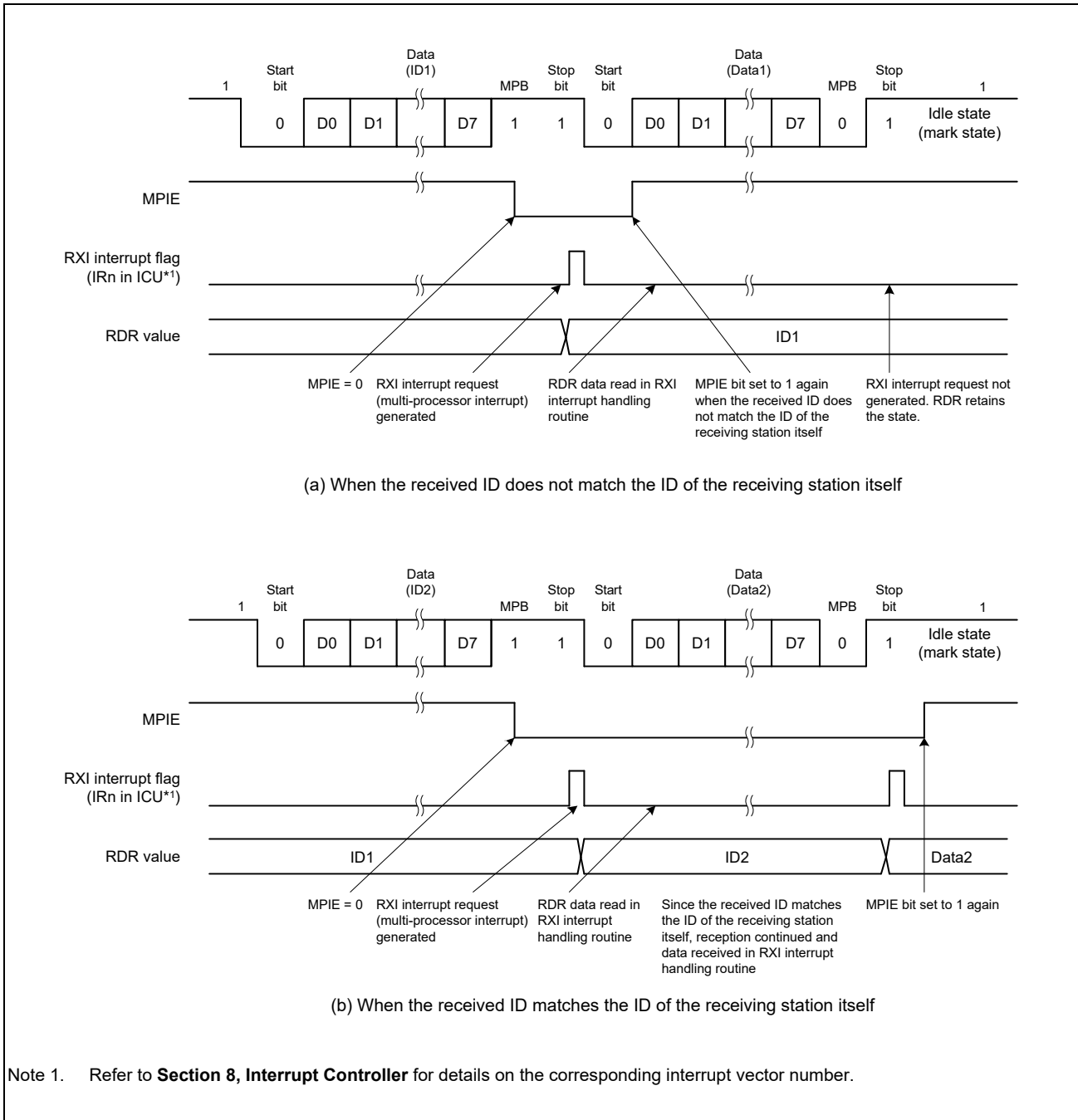

Figure 23.16 Example of SCI Reception (8-Bit Data/Multi-Processor Bit/1 Stop Bit)

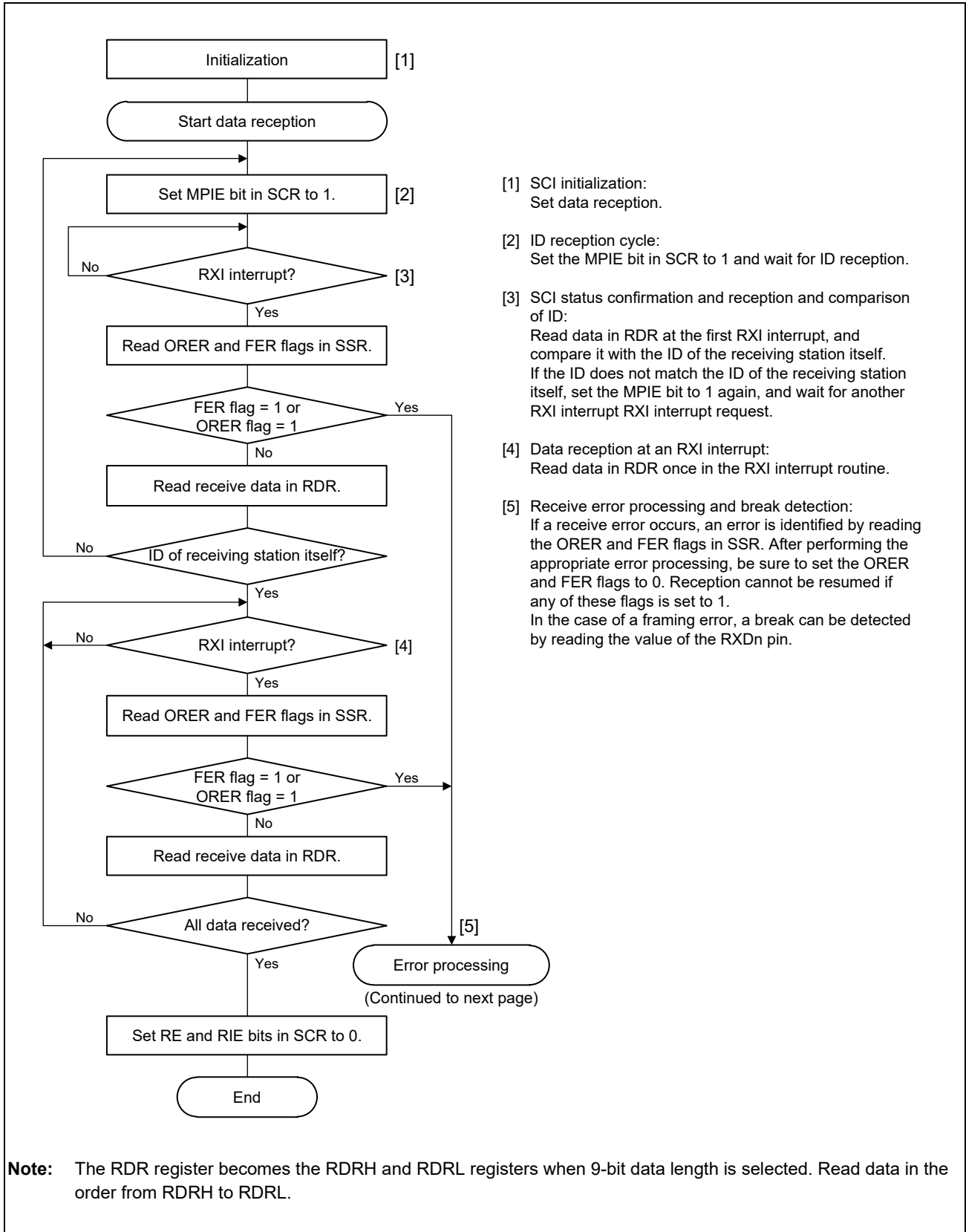

Figure 23.17 Example of Multi-Processor Serial Reception Flowchart (1)

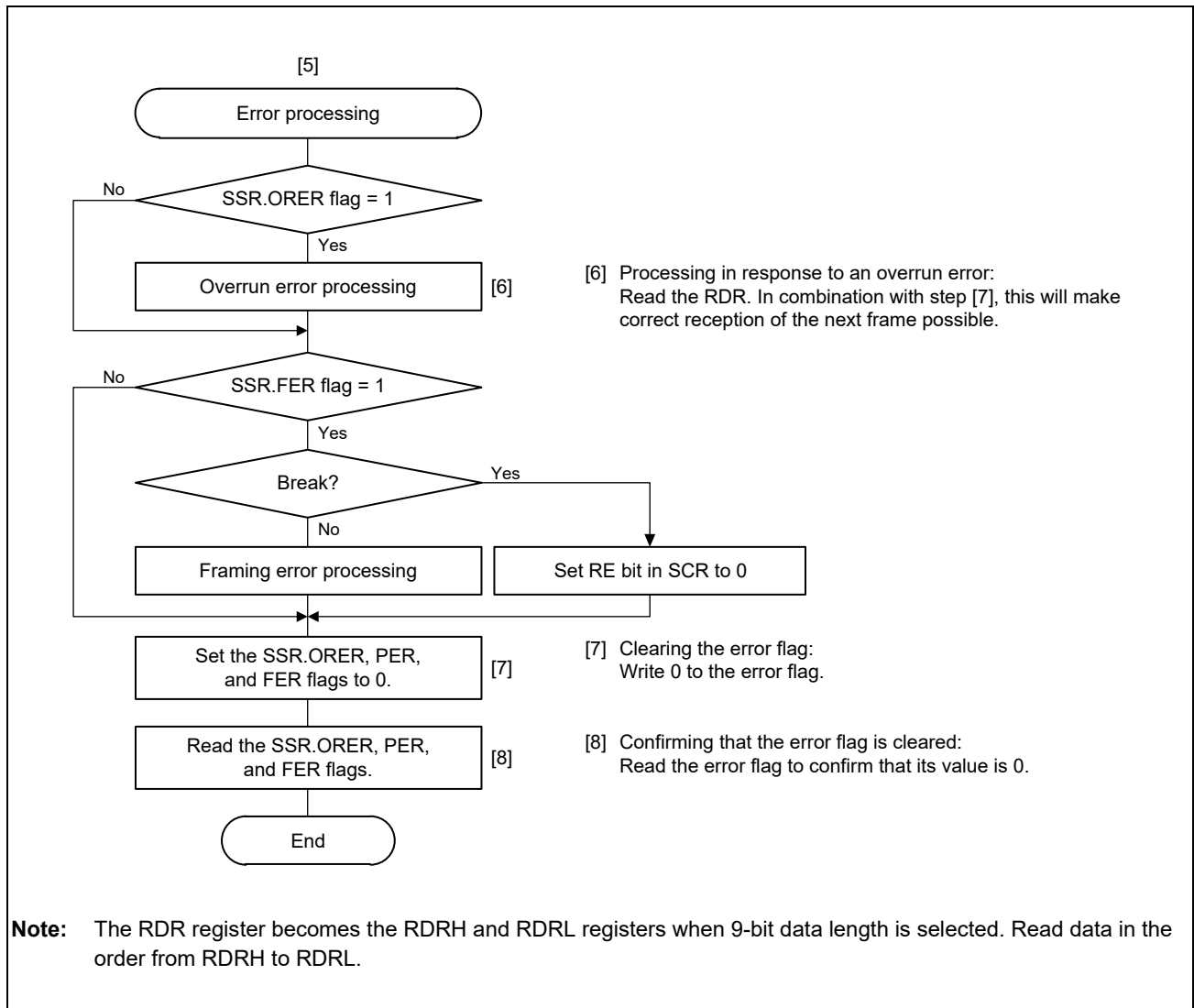

Figure 23.18 Example of Multi-Processor Serial Reception Flowchart (2)

23.5 Operation in Clock Synchronous Mode

Figure 23.19 shows the data format for clock synchronous serial data communications.

In clock synchronous mode, data is transmitted or received in synchronization with clock pulses. One character in transfer data consists of 8-bit data. In clock synchronous mode, no parity bit can be added.

In data transmission, the SCI outputs data from one falling edge of the synchronization clock to the next. In data reception, the SCI receives data in synchronization with the rising edge of the synchronization clock. After 8-bit data is output, the communication line holds the last bit output state.

Inside the SCI, the transmitter and receiver are independent units, enabling full-duplex communications by use of a common clock. Both the transmitter and the receiver also have a double-buffered structure, so that the next transmit data can be written during transmission or the previous receive data can be read during reception, enabling continuous data transfer.

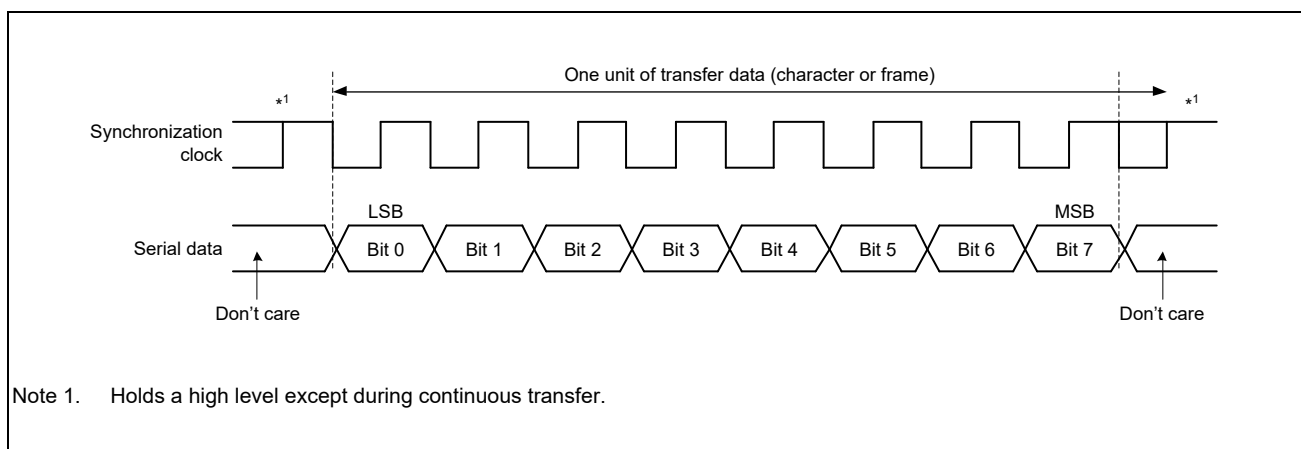

Figure 23.19 Data Format in Clock Synchronous Serial Communications (LSB First)

23.5.1 Clock

Either an internal clock generated by the on-chip baud rate generator or an external synchronization clock input at the SCKn pin can be selected, according to the setting of the SCR.CKE[1:0] bits.

When the SCI is operated on an internal clock, the synchronization clock is output from the SCKn pin. Eight synchronization clock pulses are output in the transfer of one character, and when no transfer is performed the clock is held high. However, when only data reception is performed while the CTS function is disabled, the synchronization clock output is started at the same time when the SCR.RE bit set to 1. The synchronization clock is stopped at the high level when an overrun error occurs or the SCR.RE bit is set to 0.

When only data reception is performed and the CTS function is enabled, the clock output is not started even when the SCR.RE bit set to 1 if the CTSn# pin input is high when the SCR.RE bit is 0. The synchronization clock output is started when the SCR.RE bit is set to 1 and the CTSn# pin input is low. After that, if the CTSn# pin input is high on completion of the frame reception, the synchronization clock output is stopped at the high level. If the CTSn# pin input continues to be low, the synchronization clock is stopped at the high level when an overrun error occurs or the SCR.RE bit is set to 0.

23.5.2 CTS and RTS Functions

In the CTS function, CTSn# pin input is used to control reception/transmission start when the clock source is the internal clock. Setting the SECR.CTSE bit to 1 enables the CTS function.

When the CTS function is enabled, placing the low level on the CTSn# pin causes reception/transmission to start.

In the RTS function, RTSn# pin output is used to request reception/transmission start when the clock source is an external synchronizing clock. A low level is output when serial communications become possible. Conditions for output of the low and high level are shown below.

[Conditions for low-level output] Satisfaction of all conditions listed below

- The value of the RE or TE bit in the SCR is 1
- Neither transmission nor reception is in progress
- There are no received data yet to be read (when the SCR.RE bit is 1)
- Transmit data has been written (when the SCR.TE bit is 1)
- ORER flag in SSR is 0

[Condition for high-level output]

- The conditions for low-level output have not been satisfied.

23.5.3 SCI Initialization (Clock Synchronous Mode)

Before transmitting and receiving data, start by writing the initial value H'00 to the SCR and then continue through the procedure for SCI given in **Figure 23.20**. Whenever the operating mode or transfer format is changed, the SCR must be initialized before the change is made.

Note that setting the SCR.RE bit to 0 initializes neither the ORER, FER, and PER flags in SSR nor RDR.

Moreover, note that switching the value of the SCR.TE bit from 1 to 0 or 0 to 1 while the SCR.TIE bit is 1 leads to the generation of a TXI interrupt request.

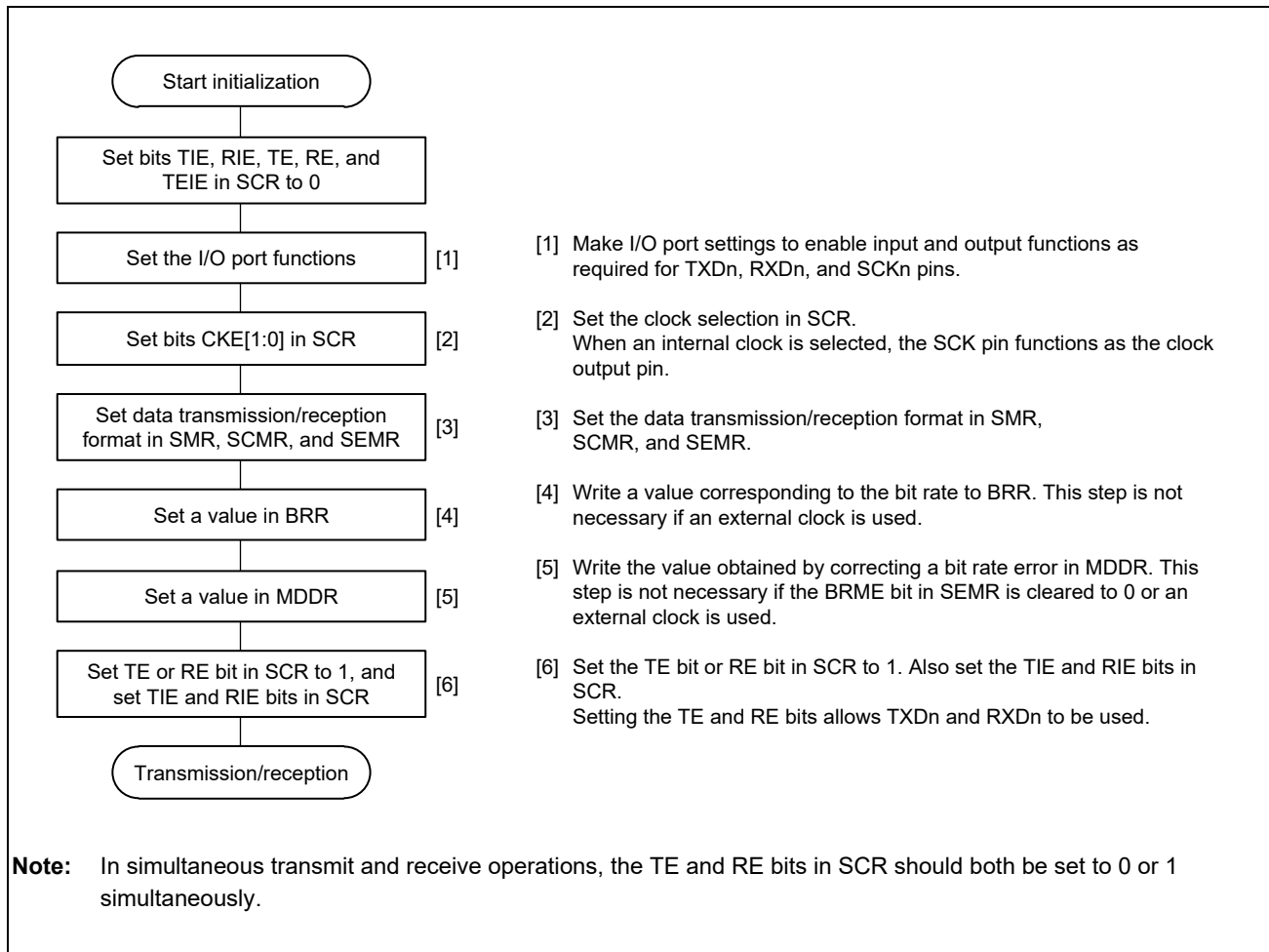

Figure 23.20 Example of SCI Initialization Flowchart (Clock Synchronous Mode)

23.5.4 Serial Data Transmission (Clock Synchronous Mode)

Figure 23.21, **Figure 23.22**, and **Figure 23.23** show an example of the operation for serial transmission in clock synchronous mode.

In serial data transmission, the SCI operates as described below.

1. The SCI transfers data from TDR to TSR when data is written to TDR in the TXI interrupt handling routine. The TXI interrupt request at the beginning of transmission is generated when the TE bit in SCR is set to 1 after the TIE bit in SCR is set to 1 or when these 2 bits are set to 1 simultaneously by a single instruction.
2. After transferring data from TDR to TSR, the SCI starts transmission. When the SCR.TIE bit is set to 1 at this time, a TXI interrupt request is generated. Continuous transmission is enabled by writing the next transmit data to TDR in this TXI interrupt handling routine before transmission of the current transmit data has finished. When TEI interrupt requests are in use, set the SCR.TIE bit to 0 (a TXI interrupt request is disabled) and the SCR.TEIE bit to 1 (a TEI interrupt request is enabled) after the last of the data to be transmitted are written to the TDR from the handling routine for TXI requests.
3. 8-bit data is sent from the TXDn pin in synchronization with the output clock when clock output mode has been specified and in synchronization with the input clock when use of an external clock has been specified. Output of the clock signal is suspended until the input CTS signal is at the low level while the CTSE bit in SECR is 1 (CTS function is enabled).
4. The SCI checks for updating of (writing to) the TDR at the time of the last bit output.
5. When TDR is updated, the next transmit data is transferred from TDR to TSR, and serial transmission of the next frame is started.
6. If TDR is not updated, set the SSR.TEND flag to 1 and the TXDn pin retains the output state of the last bit. If the TEIE bit in SCR is 1 at this time, a TEI interrupt request is generated. The SCKn pin is held high.

Figure 23.24 shows a sample flowchart of serial data transmission.

Transmission will not start while a receive error flag (ORER, FER, or PER in SSR) is set to 1. Be sure to set the receive error flags to 0 before starting transmission. Note that setting the RE bit in SCR to 0 does not clear the receive error flags.

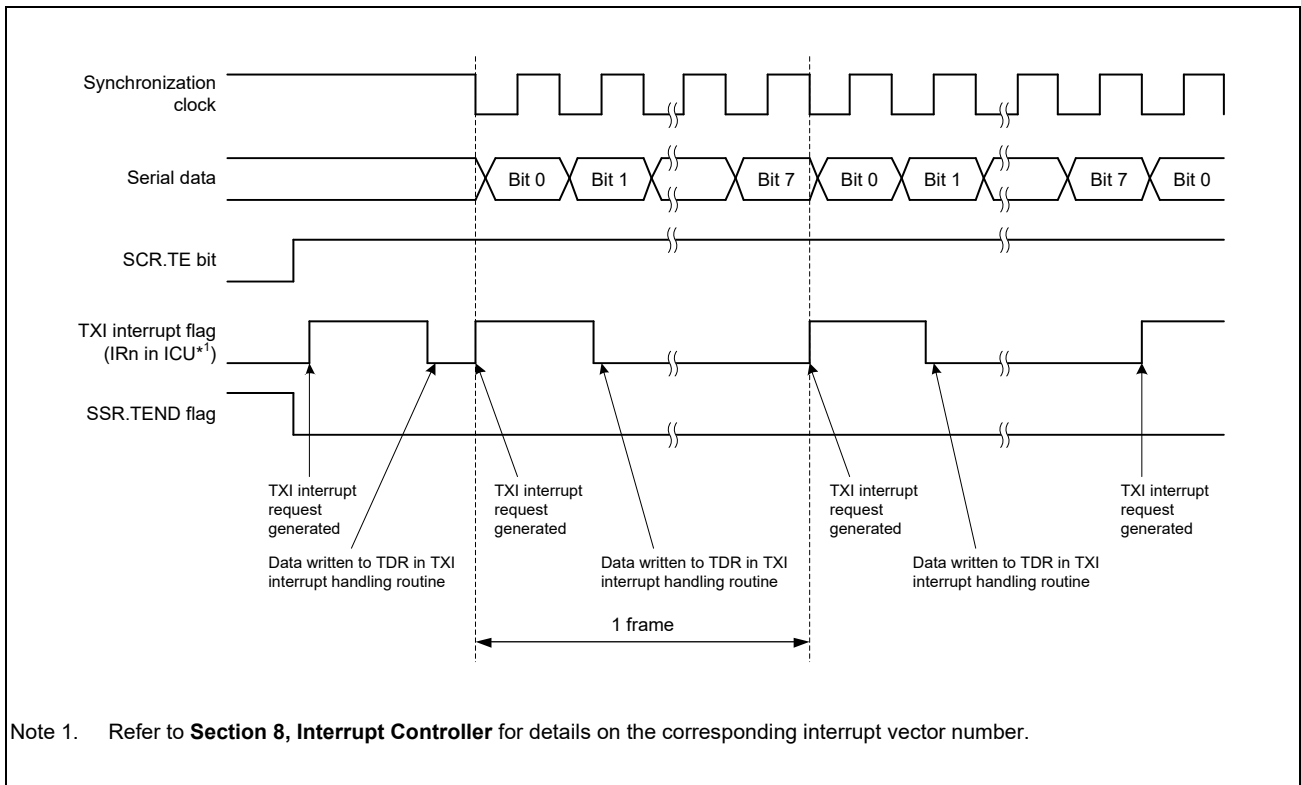

Figure 23.21 Example of Serial Data Transmission in Clock Synchronous Mode (1)
(When the CTS Function is Not Used at the Beginning of Transmission)

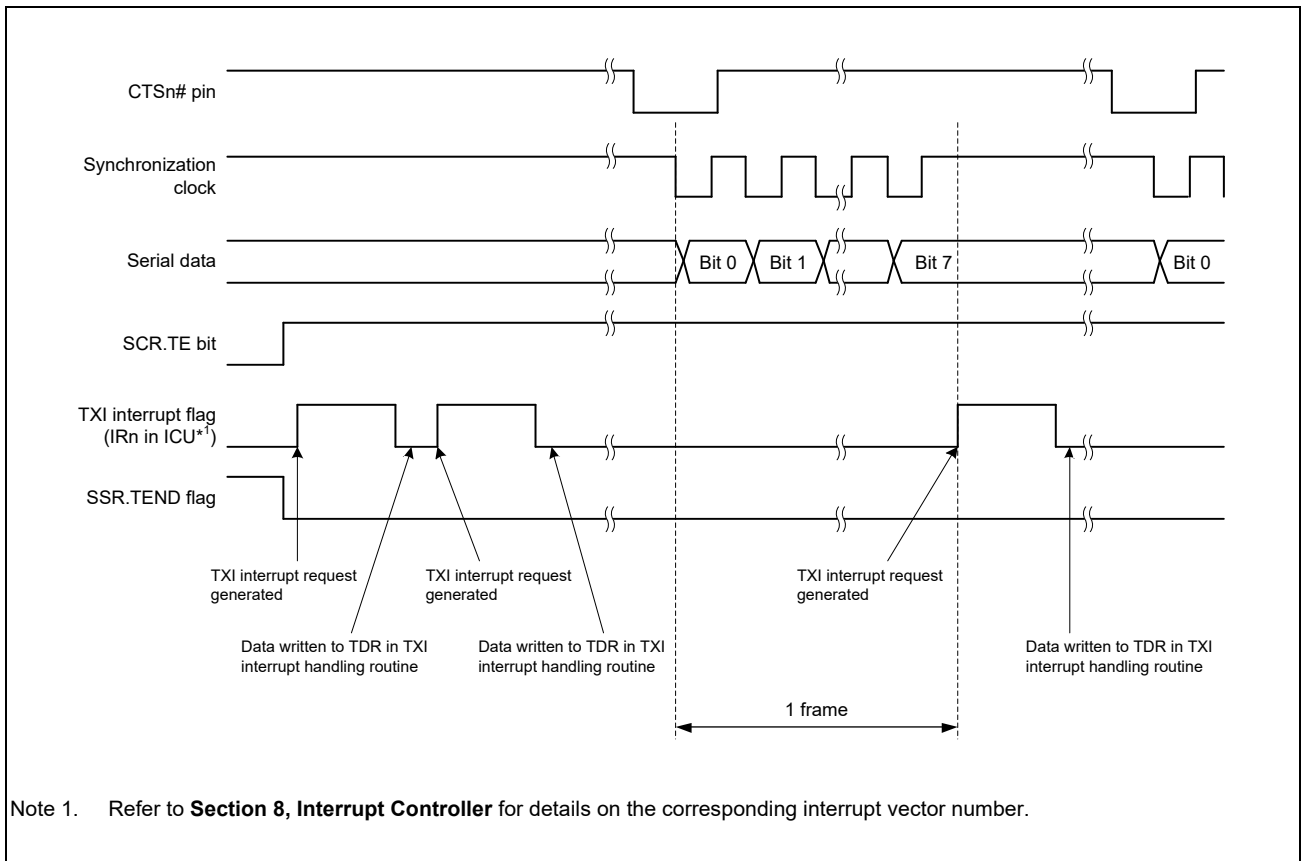

Figure 23.22 Example of Serial Data Transmission in Clock Synchronous Mode (2)
(When the CTS Function is Used at the Beginning of Transmission)

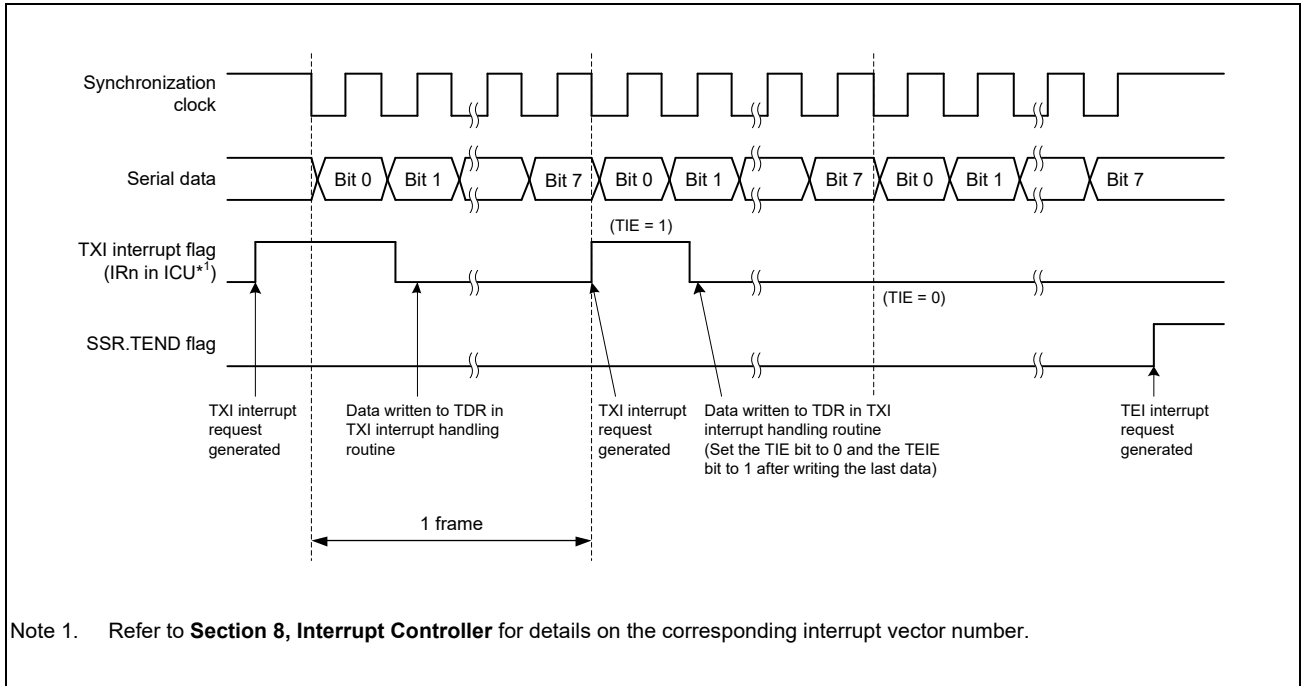

Figure 23.23 Example of Serial Data Transmission in Clock Synchronous Mode (3)
(From the Middle of Transmission until Transmission Completion)

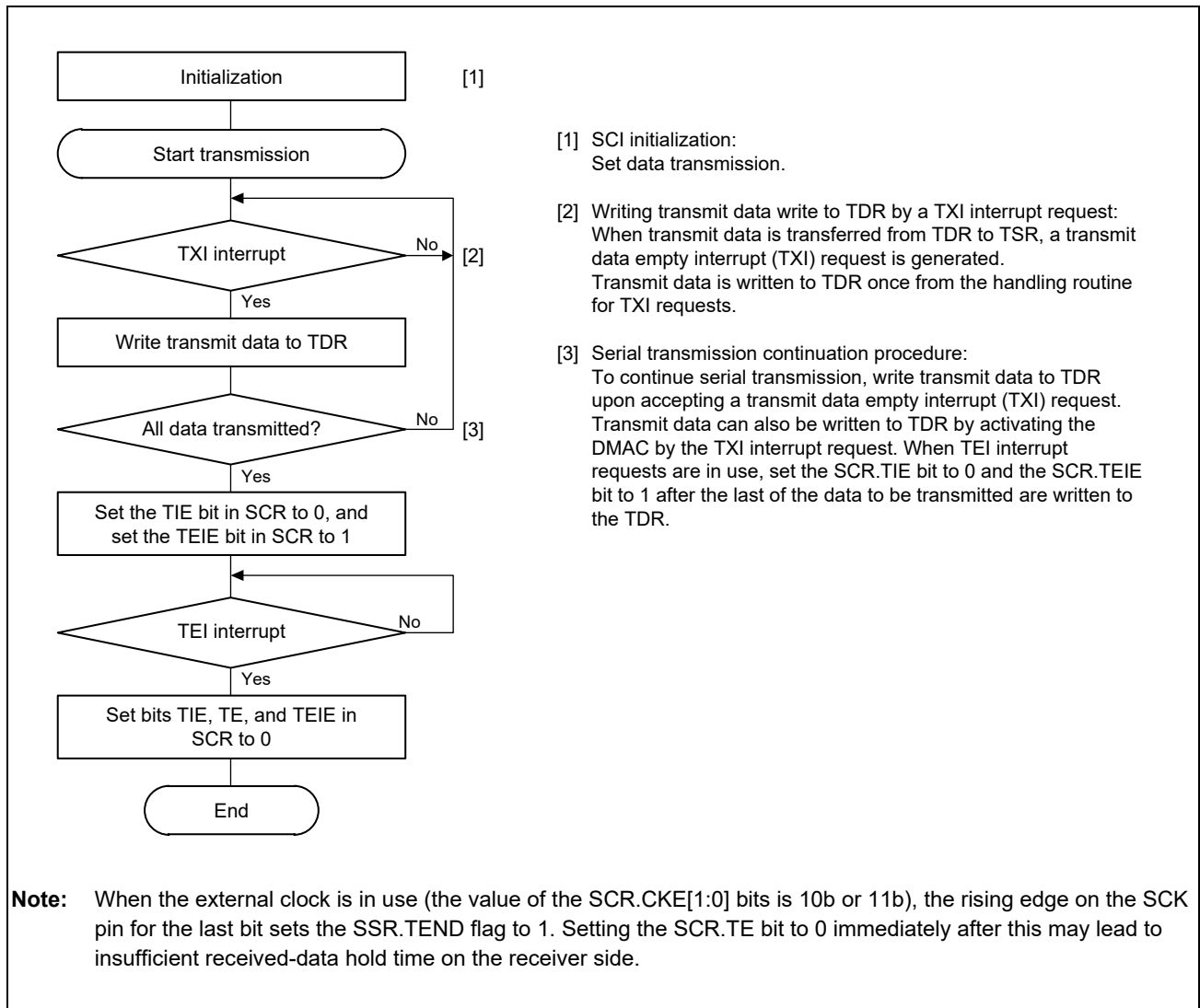

Figure 23.24 Example Flowchart of Serial Transmission in Clock Synchronous Mode

23.5.5 Serial Data Reception (Clock Synchronous Mode)

Figure 23.25 and **Figure 23.26** show an example of SCI operation for serial reception in clock synchronous mode. In serial data reception, the SCI operates as described below.

1. The value of the RE bit in SCR becoming 1 places the signal output on the RTSn# pin at the low level (when the RTS function is in use).
2. The SCI performs internal initialization and starts receiving data in synchronization with a synchronization clock input or output, and stores the receive data in RSR.
3. If an overrun error occurs, the ORER bit in SSR is set to 1. If the RIE bit in SCR is 1 at this time, an ERI interrupt request is generated. Receive data is not transferred to RDR.
4. When reception finishes successfully, receive data is transferred to RDR. If the RIE bit in SCR is 1 at this time, an RXI interrupt request is generated. Continuous reception is enabled by reading the receive data transferred to RDR in this RXI interrupt handling routine before reception of the next receive data is completed. Reading out the received data that have been transferred to RDR causes the RTSn# pin to output the low level (when the RTS function is in use).

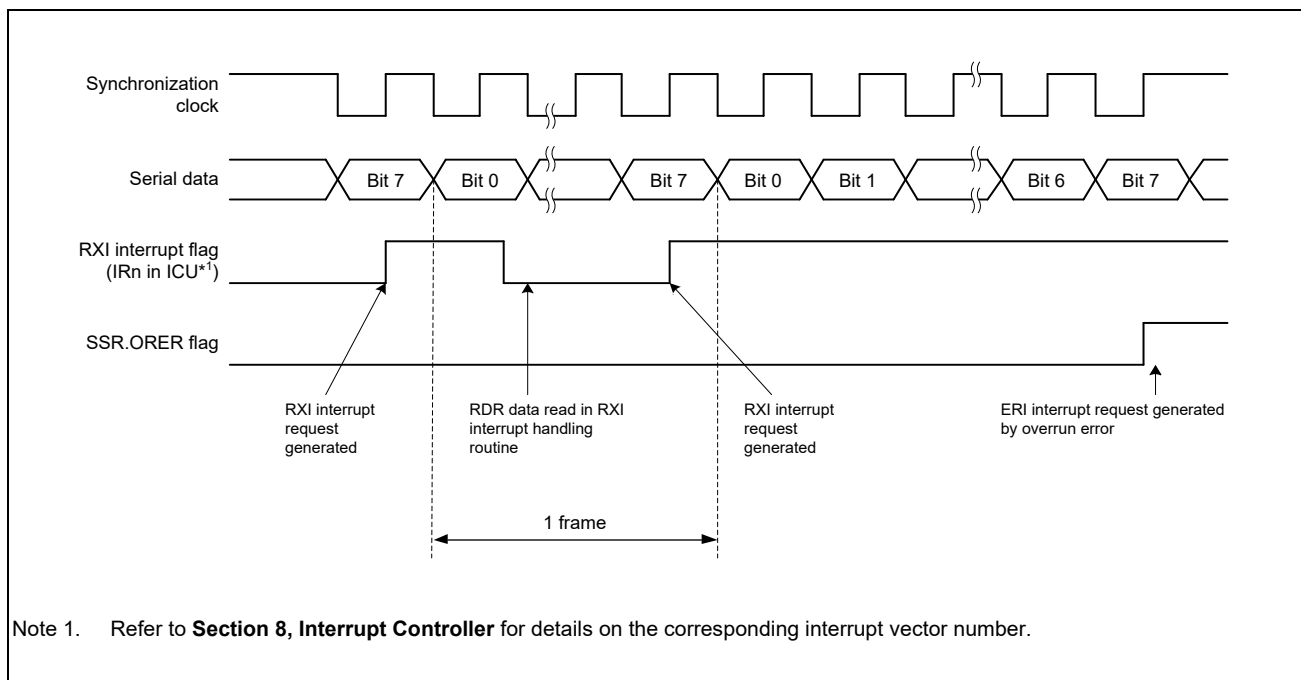

Figure 23.25 Example of Operation for Serial Reception in Clock Synchronous Mode (1)
(When RTS Function is Not Used)

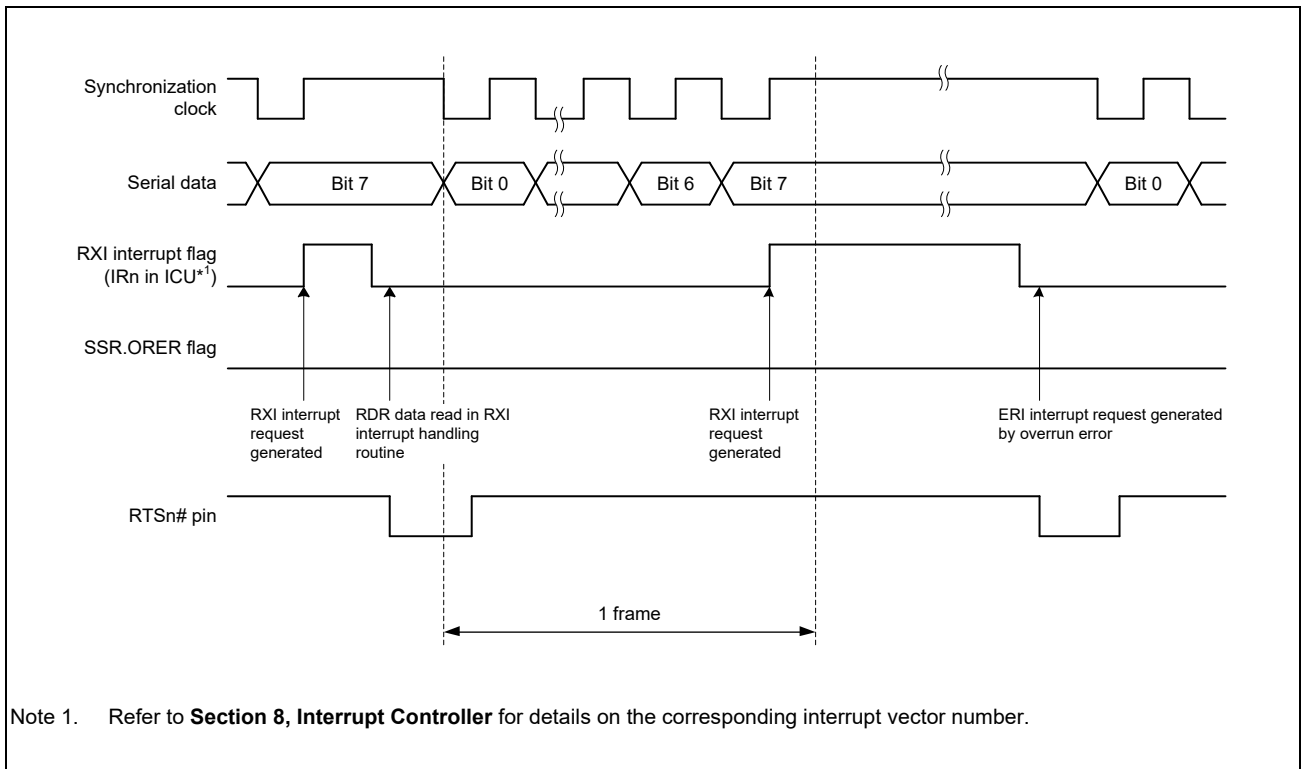

Figure 23.26 Example of Operation for Serial Reception in Clock Synchronous Mode (2) (When RTS Function is Used)

Data transfer cannot be resumed while a receive error flag is 1. Accordingly, clear the ORER, FER, and PER bits in SSR to 0 before resuming reception. Moreover, be sure to read the RDR during overrun error processing. When a reception is forcibly terminated by setting the SCR.RE bit to 0 during operation, read RDR because received data which has not yet been read may be left in RDR.

Figure 23.27 shows a sample flowchart for serial data reception.

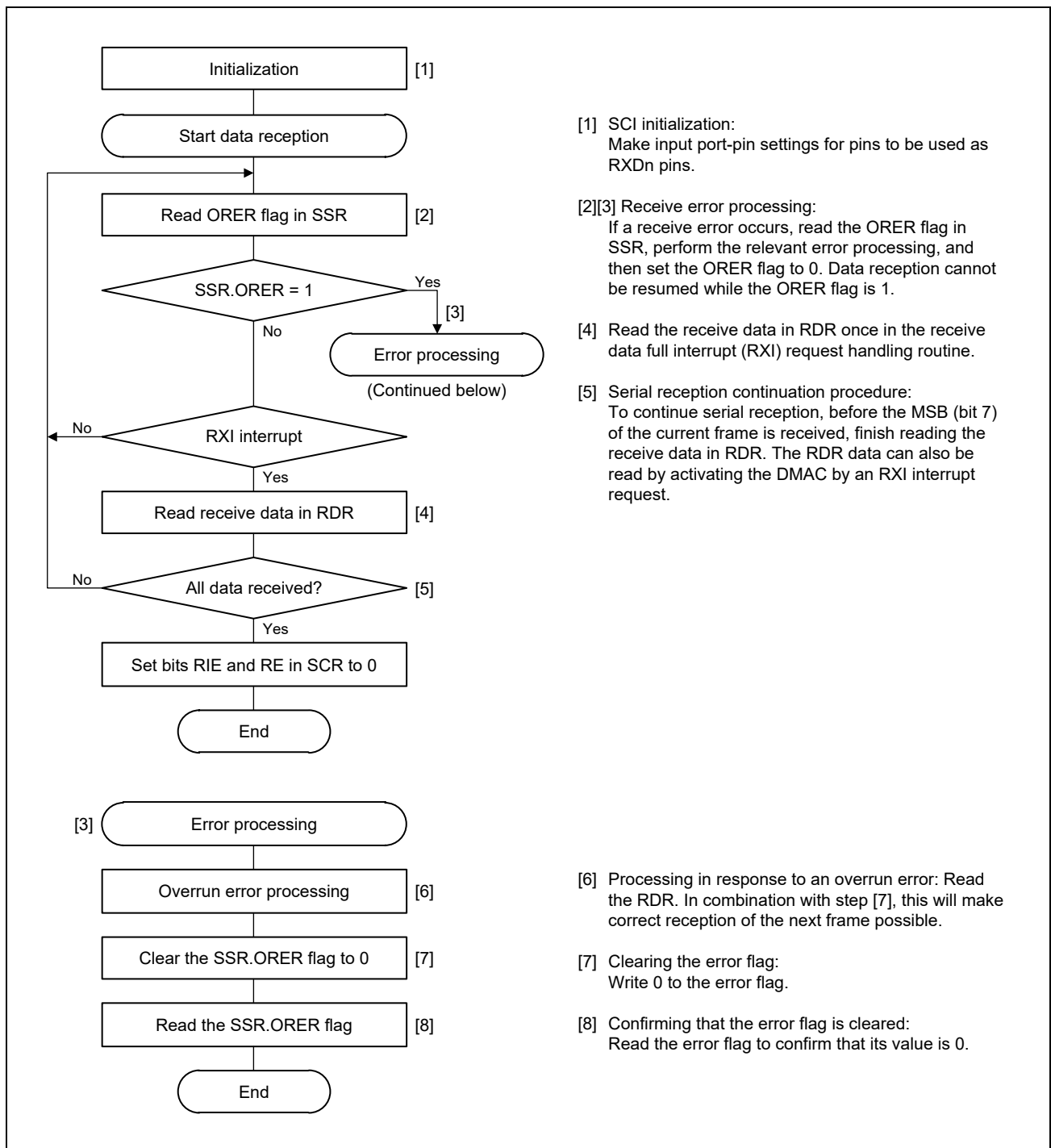

Figure 23.27 Example Flowchart of Serial Reception in Clock Synchronous Mode

23.5.6 Simultaneous Serial Data Transmission and Reception (Clock Synchronous Mode)

Figure 23.28 shows a sample flowchart for simultaneous serial transmit and receive operations in clock synchronous mode.

After initializing the SCI, the following procedure should be used for simultaneous serial data transmit and receive operations.

To switch from transmit mode to simultaneous transmit and receive mode, check that the SCI has finished transmission by reading that the TEND flag in SSR is 1, and then initialize the SCR register. Then set the TIE, RIE, TE, and RE bits in SCR to 1 simultaneously by a single instruction.

To switch from receive mode to simultaneous transmit and receive mode, check that the SCI has finished reception, and then set the RIE and RE bits to 0. Then check that the receive error flags (ORER, FER, and PER in SSR) are 0, and then set the TIE, RIE, TE, and RE bits in SCR to 1 simultaneously by a single instruction.

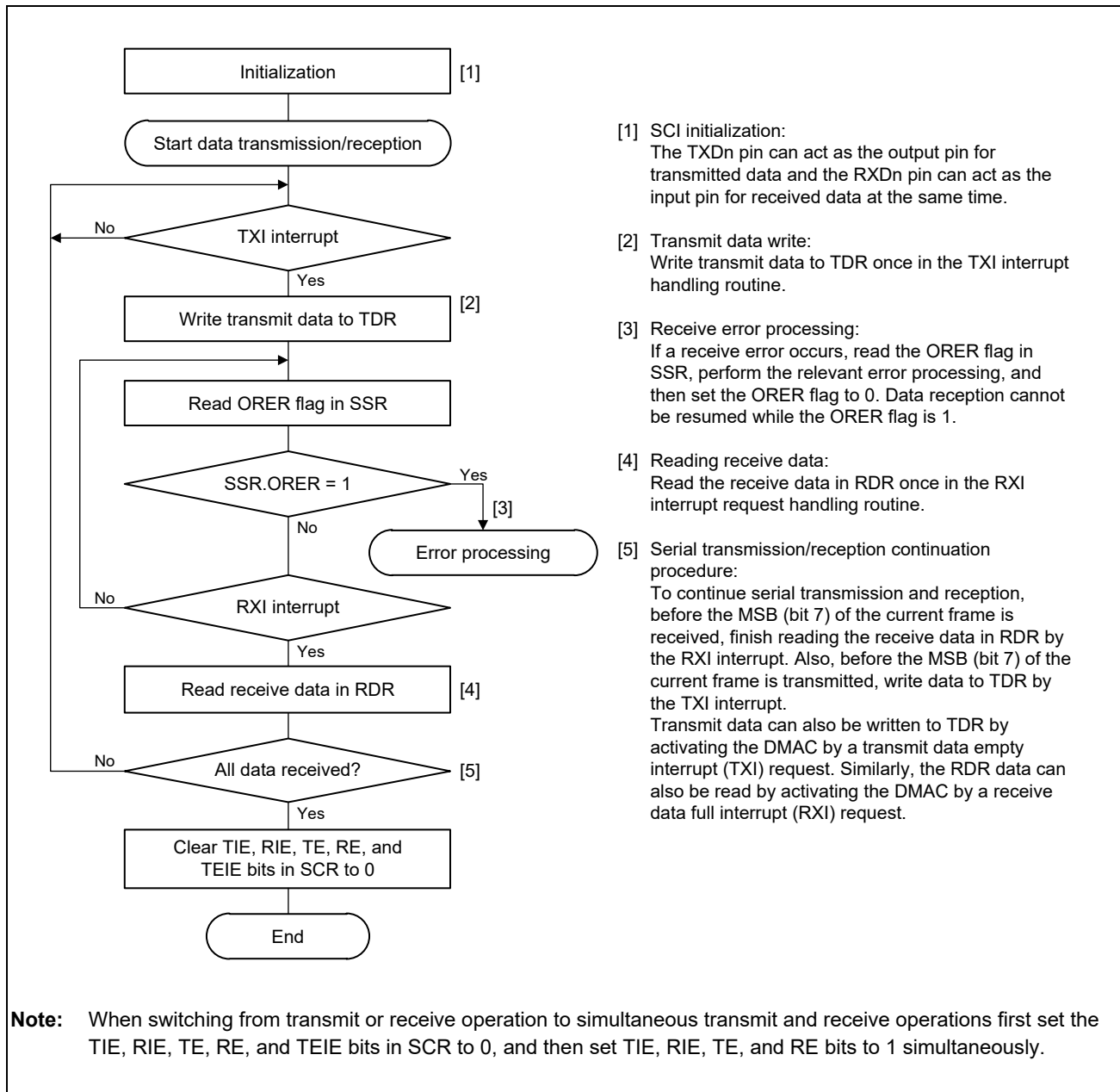

Figure 23.28 Example Flowchart of Simultaneous Serial Transmission and Reception in Clock Synchronous Mode

23.6 Operation in Smart Card Interface Mode

The SCI supports smart card (IC card) interfaces conforming to ISO/IEC 7816-3 (standard for Identification Cards), as an extended function of the SCI.

Smart card interface mode can be selected using the appropriate register.

23.6.1 Sample Connection

Figure 23.29 shows a sample connection between a smart card (IC card) and this MCU.

As in the figure, since this MCU communicates with an IC card using a single transmission line, interconnect the TXDn and RXDn pins and pull up the data transmission line to VCC using a resistor.

Setting the TE and RE bits in SCR to 1 with an IC card disconnected enables closed transmission/reception allowing self-diagnosis.

To supply an IC card with the clock pulses generated by the SCI, input the SCKn pin output to the CLK pin of an IC card. The output port of this MCU can be used to output a reset signal.

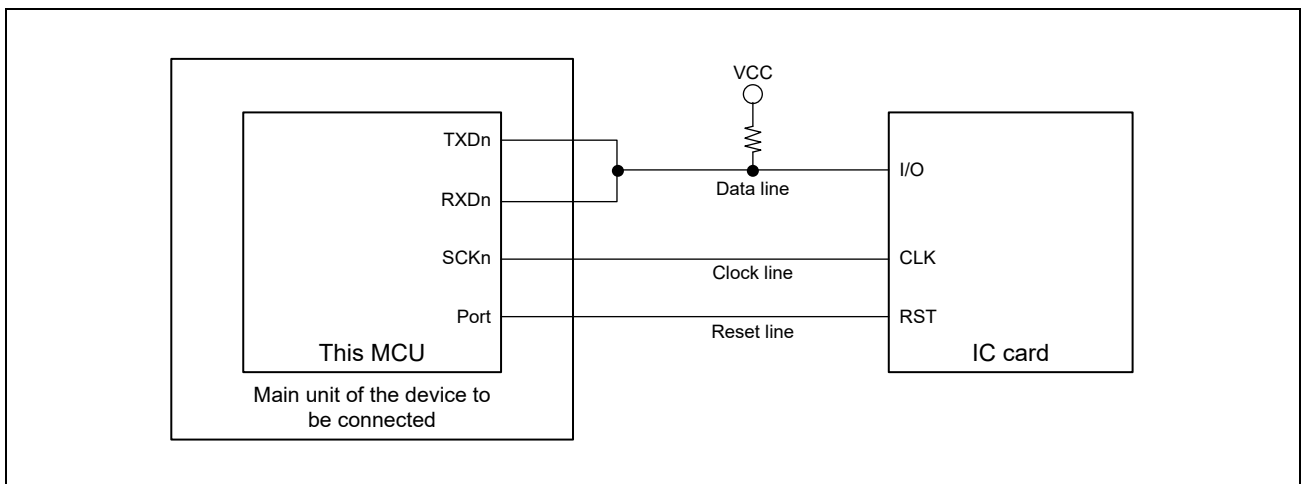

Figure 23.29 Sample Connection with a Smart Card (IC Card)

23.6.2 Data Format (Except in Block Transfer Mode)

Figure 23.30 shows the data transfer formats in smart card interface mode.

- One frame consists of 8-bit data and a parity bit in asynchronous mode.
- During transmission, at least 2 etu (elementary time unit: time required for transferring 1 bit) is secured as a guard time from the end of the parity bit until the start of the next frame.
- If a parity error is detected during reception, a low-level error signal is output for 1 etu after 10.5 etu has passed from the start bit.
- If an error signal is sampled during transmission, the same data is automatically retransmitted after at least 2 etu.

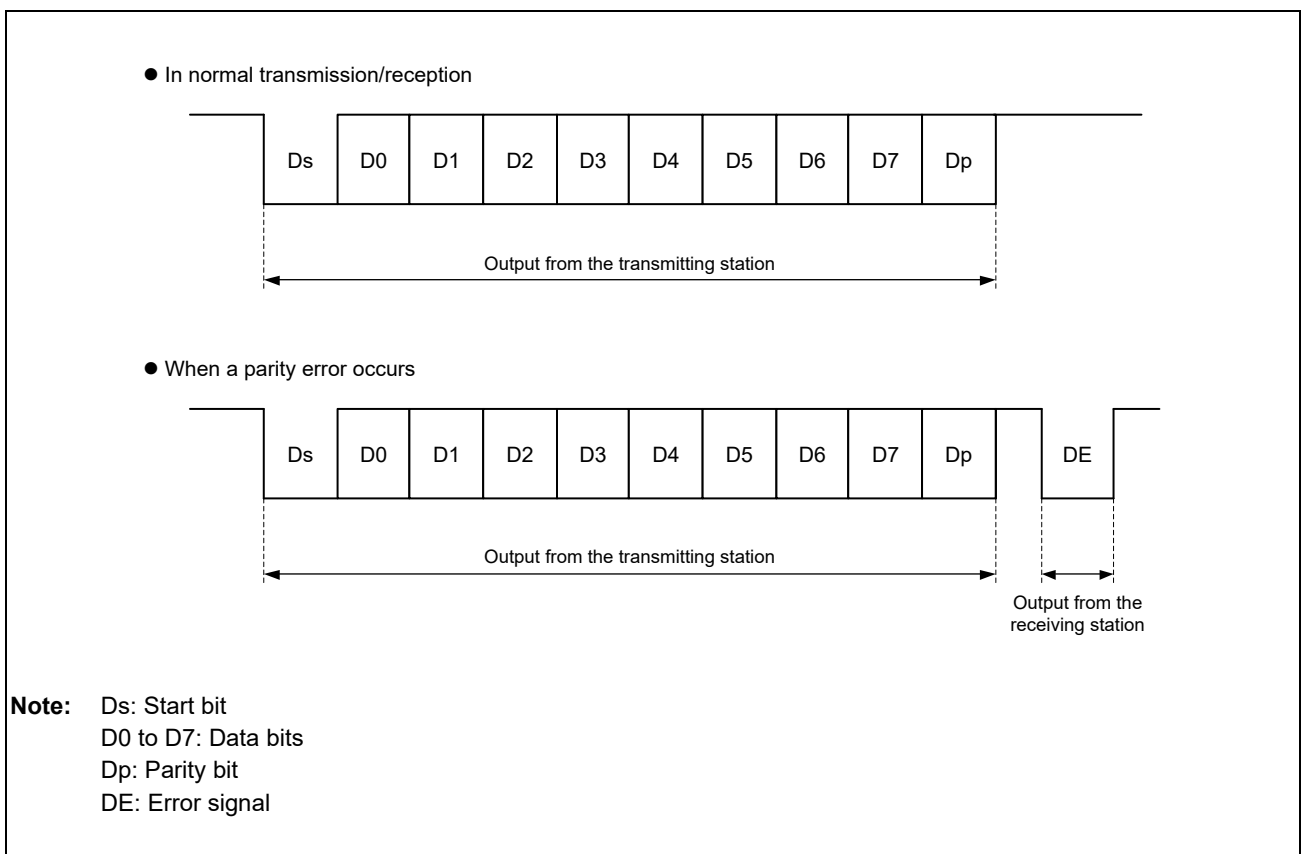

Figure 23.30 Data Formats in Smart Card Interface Mode

For communications with IC cards of the direct convention type and inverse convention type, follow the procedure below.

(1) Direct Convention Type

For the direct convention type, logic levels 1 and 0 correspond to states Z and A, respectively, and data is transferred with LSB first as the start character, as shown in **Figure 23.31**. Therefore, data in the start character in the figure is H'3B.

When using the direct convention type, write 0 to both the SDIR and SINV bits in SCMR. Write 0 to the PM bit in SMR in order to use even parity, which is prescribed by the smart card standard.

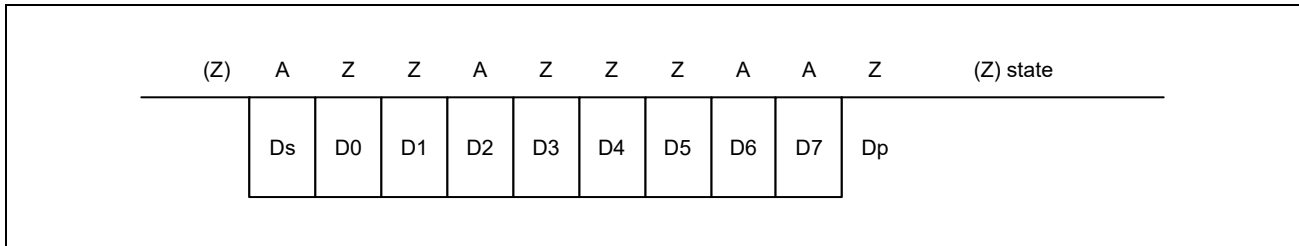

Figure 23.31 Direct Convention (SDIR in SCMR = 0, SINV in SCMR = 0, PM in SMR = 0)

(2) Inverse Convention Type

For the inverse convention type, logic levels 1 and 0 correspond to states A and Z, respectively and data is transferred with MSB first as the start character, as shown in **Figure 23.32**. Therefore, data in the start character in the figure is H'3F. When using the inverse convention type, write 1 to both the SDIR and SINV bits in SCMR. The parity bit is logic level 0 to produce even parity, which is prescribed by the smart card standard, and corresponds to state Z. Since the SINV bit of this MCU only inverts data bits D7 to D0, write 1 to the PM bit in SMR to invert the parity bit for both transmission and reception.

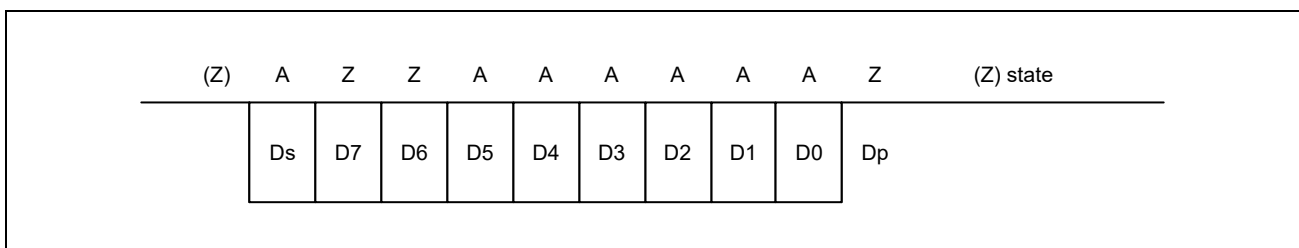

Figure 23.32 Inverse Convention (SDIR in SCMR = 1, SINV in SCMR = 1, PM in SMR = 1)

23.6.3 Block Transfer Mode

Block transfer mode is different from normal smart card interface mode in the following respects.

- Even if a parity error is detected during reception, no error signal is output. Since the PER bit in SSR is set by error detection, clear the PER bit before receiving the parity bit of the next frame.
- During transmission, at least 1 etu is secured as a guard time from the end of the parity bit until the start of the next frame.
- Since the same data is not retransmitted during transmission, the TEND flag in SSR is set 11.5 etu after transmission start.
- In block transfer mode, the ERS flag in SSR indicates the error signal status as in normal smart card interface mode, but the flag is read as 0 because no error signal is transferred.

23.6.4 Receive Data Sampling Timing and Reception Margin

Only the internal clock generated by the on-chip baud rate generator can be used as a transfer clock in smart card interface mode.

In this mode, the SCI can operate on a base clock with a frequency of 32, 64, 372, 256, 93, 128, 186, or 512 times the bit rate according to the settings of the BCP2 bit in SCMR and the BCP[1:0] bits in SMR (the frequency is always 16 times the bit rate in normal asynchronous mode).

For data reception, the falling edge of the start bit is sampled with the base clock to perform internal synchronization. Receive data is sampled on the 16th, 32nd, 186th, 128th, 46th, 64th, 93rd, and 256th rising edges of the base clock so that it can be latched at the middle of each bit as shown in **Figure 23.33**. The reception margin here is determined by the following formula.

$$M = \left| \left(0.5 - \frac{1}{2N} \right) - (L - 0.5)F - \frac{|D - 0.5|}{N} (1 + F) \right| \times 100 [\%]$$

M: Reception margin (%)

N: Ratio of bit rate to clock (N = 32, 64, 372, 256) D: Duty cycle of clock (D = 0 to 1.0)

L: Frame length (L = 10)

F: Absolute value of clock frequency deviation

Assuming values of F = 0, D = 0.5, and N = 372 in the above formula, the reception margin is determined by the formula below.

$$M = \{ 0.5 - 1/(2 \times 372) \} \times 100 [\%] = 49.866\%$$

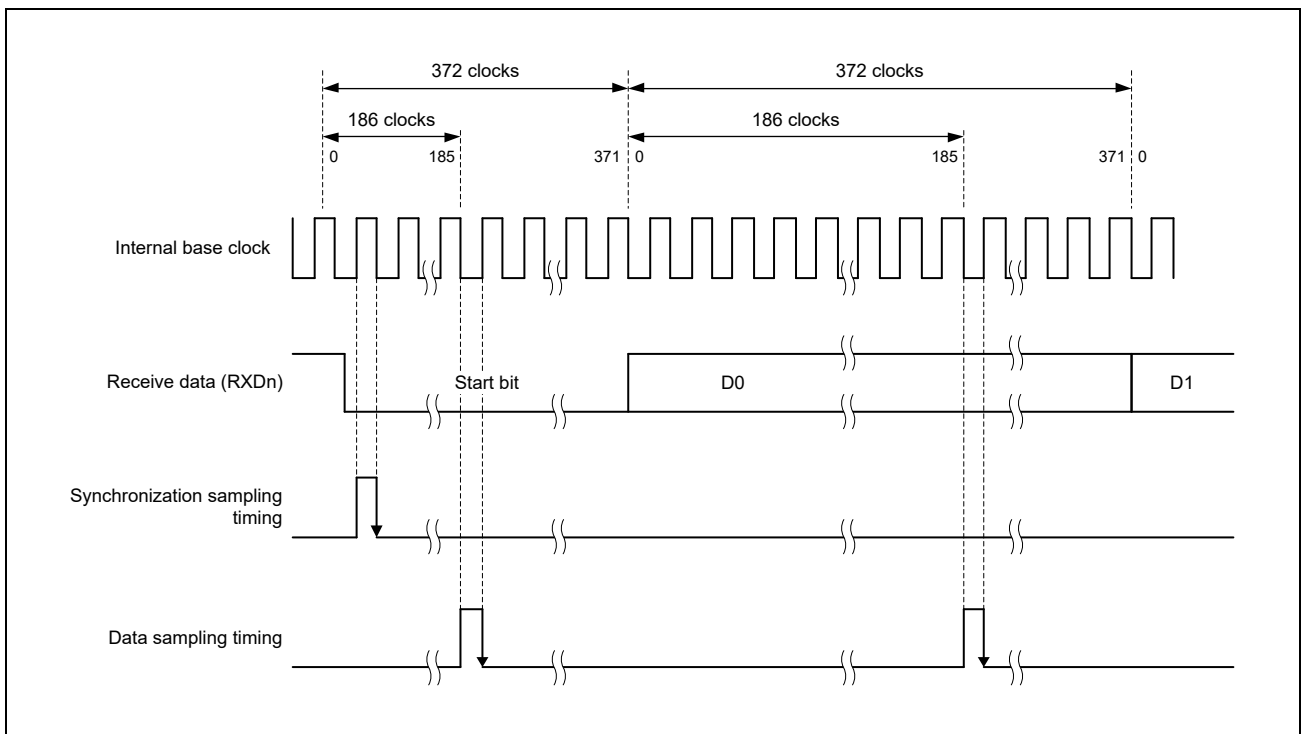

Figure 23.33 Receive Data Sampling Timing in Smart Card Interface Mode
(When Clock Frequency is 372 Times the Bit Rate)

23.6.5 SCI Initialization (Smart Card Interface Mode)

Initialize the SCI following the example of flowchart shown in **Figure 23.34**.

Be sure to initialize the SCI before switching from transmission mode to reception mode and vice versa. Even if the RE bit is set to 0, the RDR register is not initialized.

To change reception mode to transmission mode, first check that reception has completed, and then initialize the SCI. At the end of initialization, set TE = 1 and RE = 0. Reception completion can be verified by reading the RXI request, ORER, or PER flag in SSR.

To change transmission mode to reception mode, first check that transmission has completed, and then initialize the SCI. At the end of initialization, set TE = 0 and RE = 1. Transmission completion can be verified by reading the TEND flag in SSR.

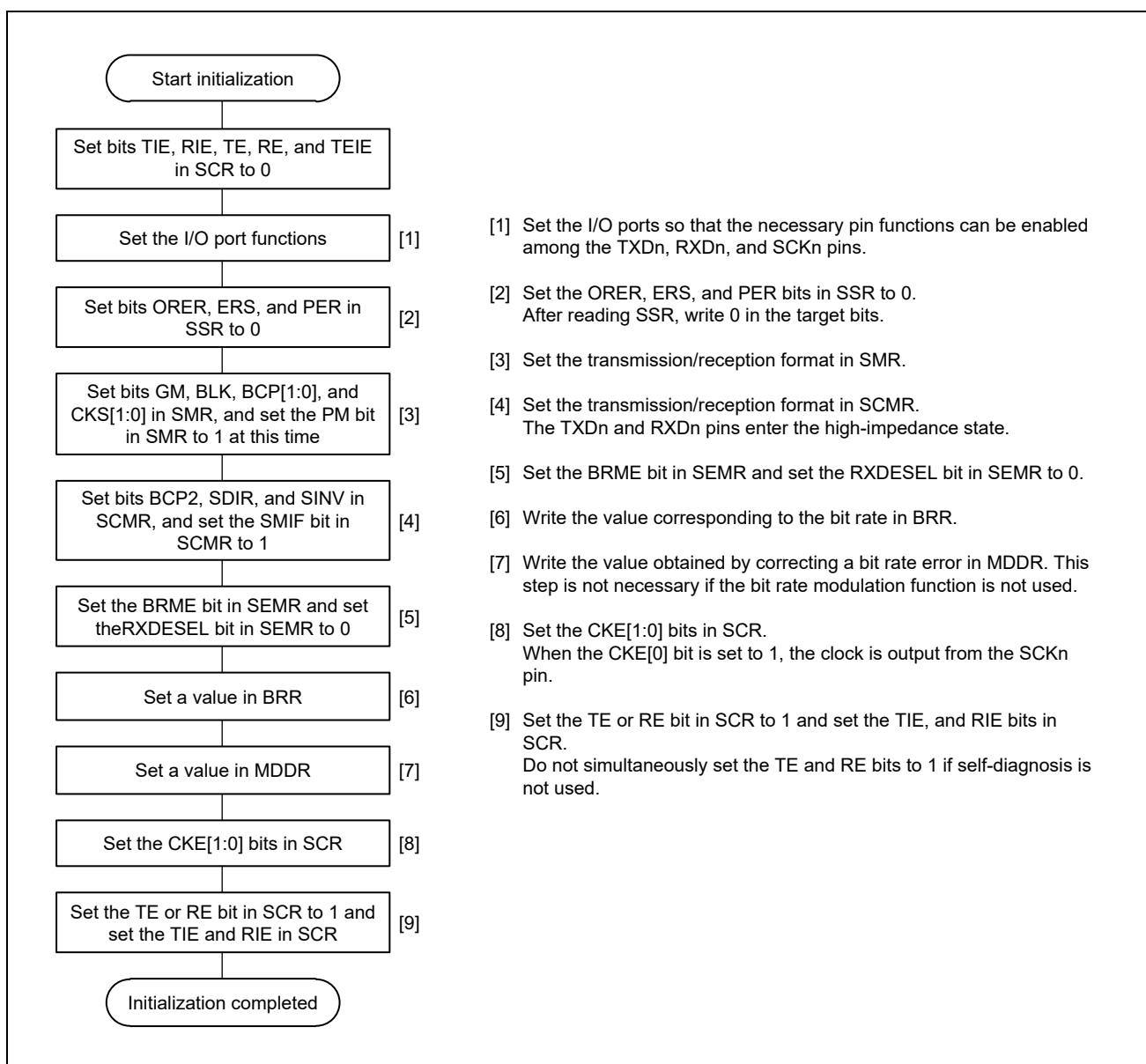

Figure 23.34 Example of SCI Initialization Flowchart (Smart Card Interface Mode)

23.6.6 Serial Data Transmission (Except in Block Transfer Mode)

Serial data transmission in smart card interface mode (except in block transfer mode), in that an error signal is sampled and data can be retransmitted, is different from that in non-smart card interface mode. **Figure 23.35** shows the data retransfer operation during transmission.

1. When an error signal from the receiver end is sampled after one-frame data has been transmitted, the ERS flag in SSR is set to 1. If the RIE bit in SCR is 1 at this time, an ERI interrupt request is generated. Clear the ERS flag to 0 before the next parity bit is sampled.
2. For a frame in which an error signal is received, the TEND flag in SSR is not set. Data is retransferred from TDR to TSR allowing automatic data retransmission.
3. If no error signal is returned from the receiver, the ERS flag is not set to 1.
4. In this case, the SCI judges that transmission of one-frame data (including retransfer) has been completed, and the TEND flag is set. If the TIE bit in SCR is 1 at this time, a TXI interrupt request is generated. Writing transmit data to TDR starts transmission of the next data.

Figure 23.37 shows a sample flowchart of serial transmission. All the processing steps are automatically performed using a TXI interrupt request to activate the DMAC.

When the TEND flag in SSR is set to 1 in transmission, if the TIE bit in SCR is 1, a TXI interrupt request is generated. The DMAC is activated by a TXI interrupt request if the TXI interrupt request is specified as a source of DMAC activation beforehand, allowing transfer of transmit data. The TEND flag is automatically set to 0 when the DMAC transfers the data.

If an error occurs, the SCI automatically retransmits the same data. During this retransmission, the TEND flag is kept to 0 and the DMAC is not activated. Therefore, the SCI and DMAC automatically transmit the specified number of bytes, including retransmission in the case of error occurrence. However, since the ERS flag is not automatically cleared, set the RIE bit to 1 beforehand to enable an ERI interrupt request to be generated at error occurrence, and clear the ERS flag to 0. When transmitting/receiving data using the DMAC, be sure to make settings to enable the DMAC before making SCI settings.

For DMAC settings, refer to **Section 14, Direct Memory Access Controller**.

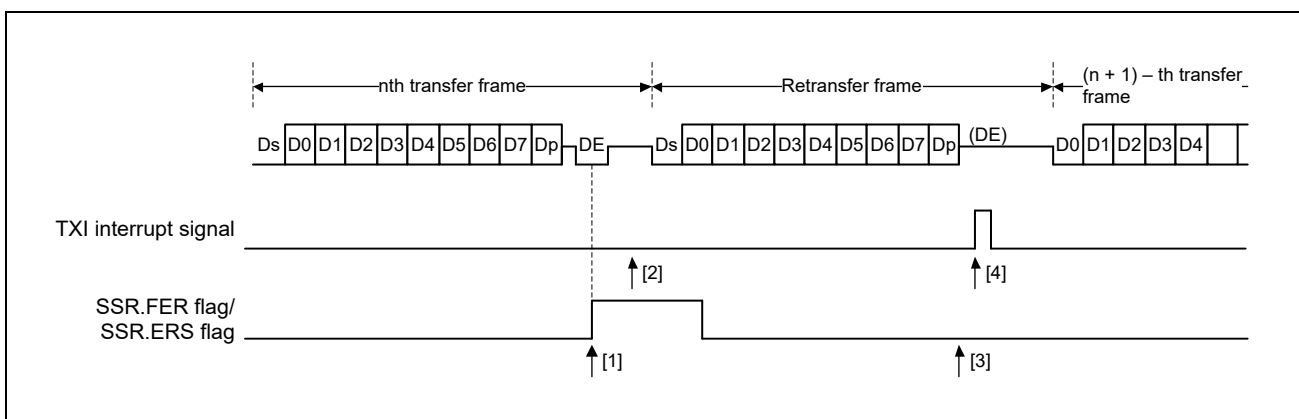

Figure 23.35 Data Retransfer Operation in SCI Transmission Mode

Note that the SSR.TEND flag is set in different timings depending on the GM bit setting in SMR. **Figure 23.36** shows the TEND flag generation timing.

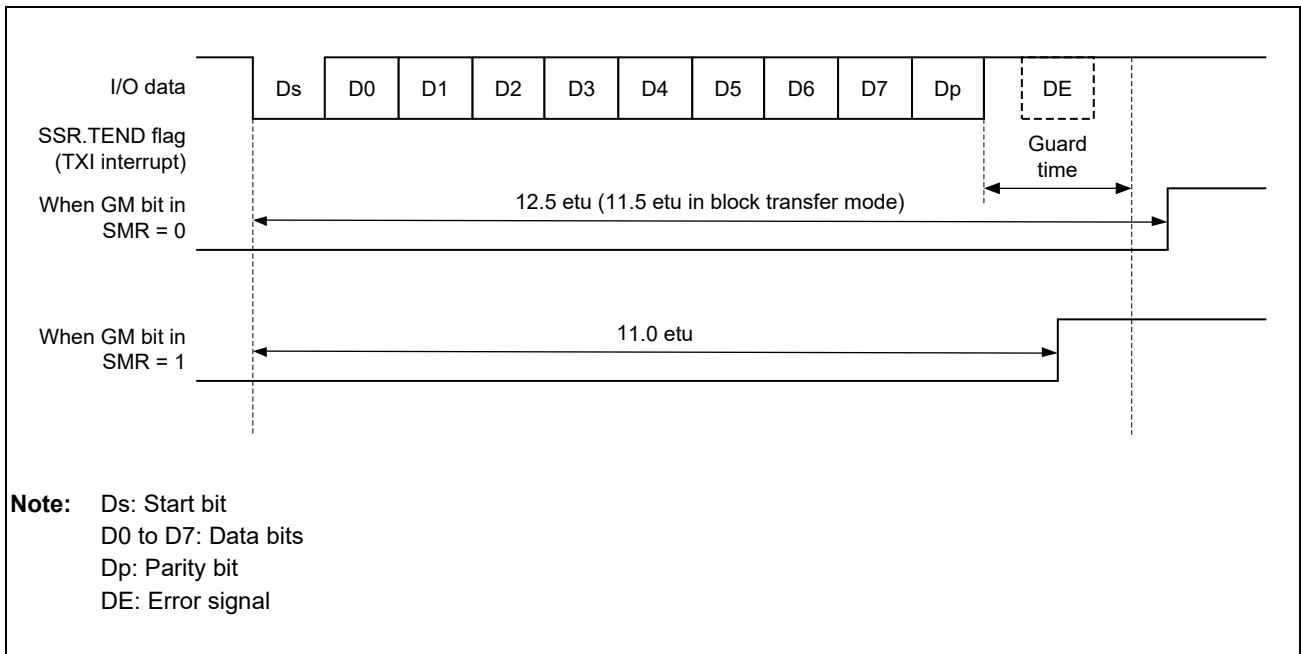

Figure 23.36 SSR.TEND Flag Generation Timing during Transmission

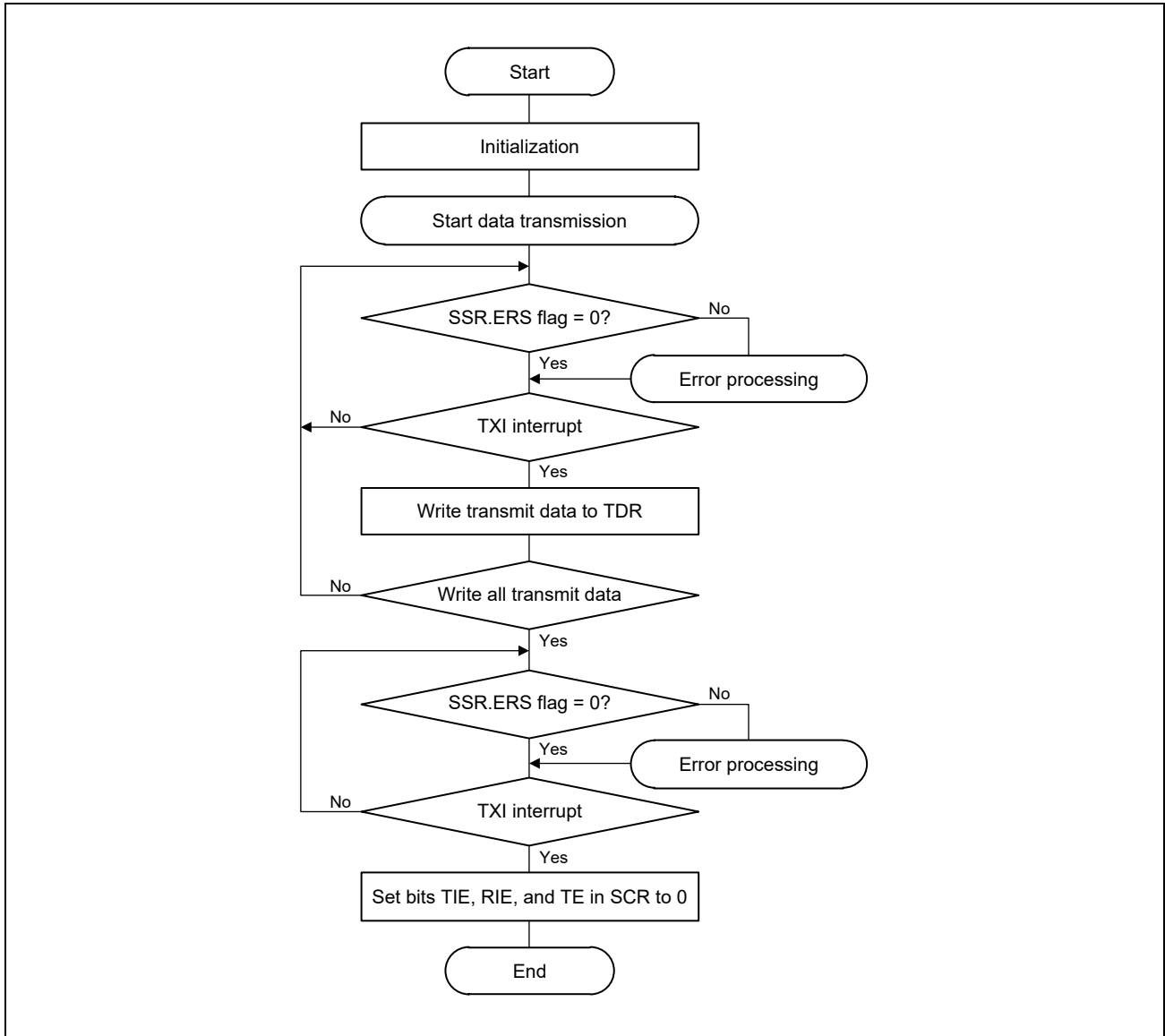

Figure 23.37 Sample Smart Card Interface Transmission Flowchart

23.6.7 Serial Data Reception (Except in Block Transfer Mode)

Serial data reception in smart card interface mode is similar to that in non-smart card interface mode. **Figure 23.38** shows the data retransfer operation in reception mode.

1. If a parity error is detected in receive data, the PER flag in SSR is set to 1. When the RIE bit in SCR is 1 at this time, an ERI interrupt request is generated. Clear the PER flag to 0 before the next parity bit is sampled.
2. For a frame in which a parity error is detected, no RXI interrupt is generated.
3. When no parity error is detected, the PER flag in SSR is not set to 1.
4. In this case, data is determined to have been received successfully. When the RIE bit in SCR is 1, an RXI interrupt request is generated.

Figure 23.39 shows a sample flowchart for serial data reception. All the processing steps are automatically performed using an RXI interrupt request to activate the DMAC.

In reception, setting the RIE bit to 1 allows an RXI interrupt request to be generated. The DMAC is activated by an RXI interrupt request if the RXI interrupt request is specified as a source of DMAC activation beforehand, allowing transfer of receive data.

If an error occurs during reception and either the ORER or PER flag in SSR is set to 1, a receive error interrupt (ERI) request is generated. Clear the error flag after the error occurrence. If an error occurs, the DMAC is not activated and receive data is skipped. Therefore, the number of bytes of receive data specified in the DMAC is transferred.

Even if a parity error occurs and the PER flag is set to 1 during reception, receive data is transferred to RDR, thus allowing the data to be read.

When a reception is forcibly terminated by setting the RE bit in SCR to 0 during operation, read the RDR register because the received data which has not yet been read may be left in RDR.

NOTE

For operations in block transfer mode, refer to **Section 23.3, Operation in Asynchronous Mode**.

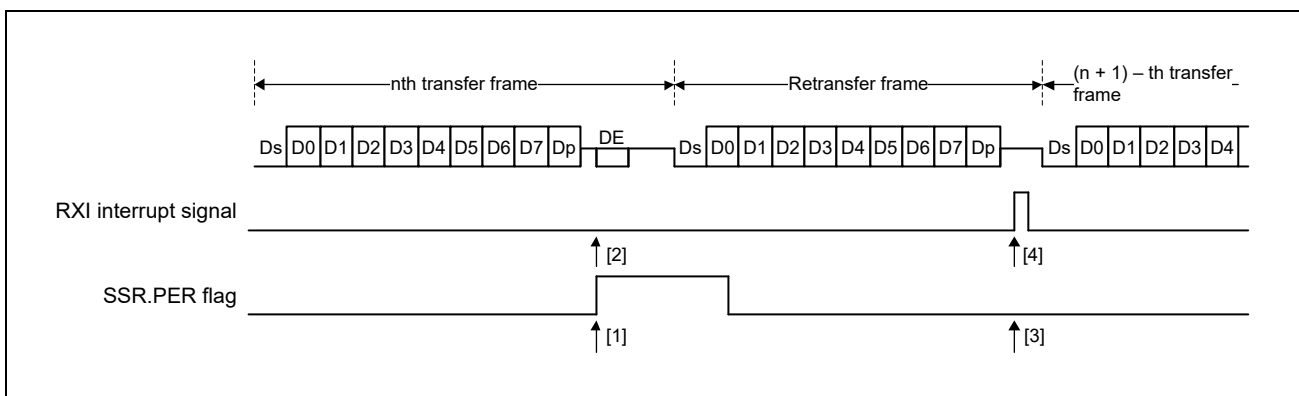

Figure 23.38 Data Retransfer Operation in SCI Reception Mode (Data Retransfer Operation during Reception)

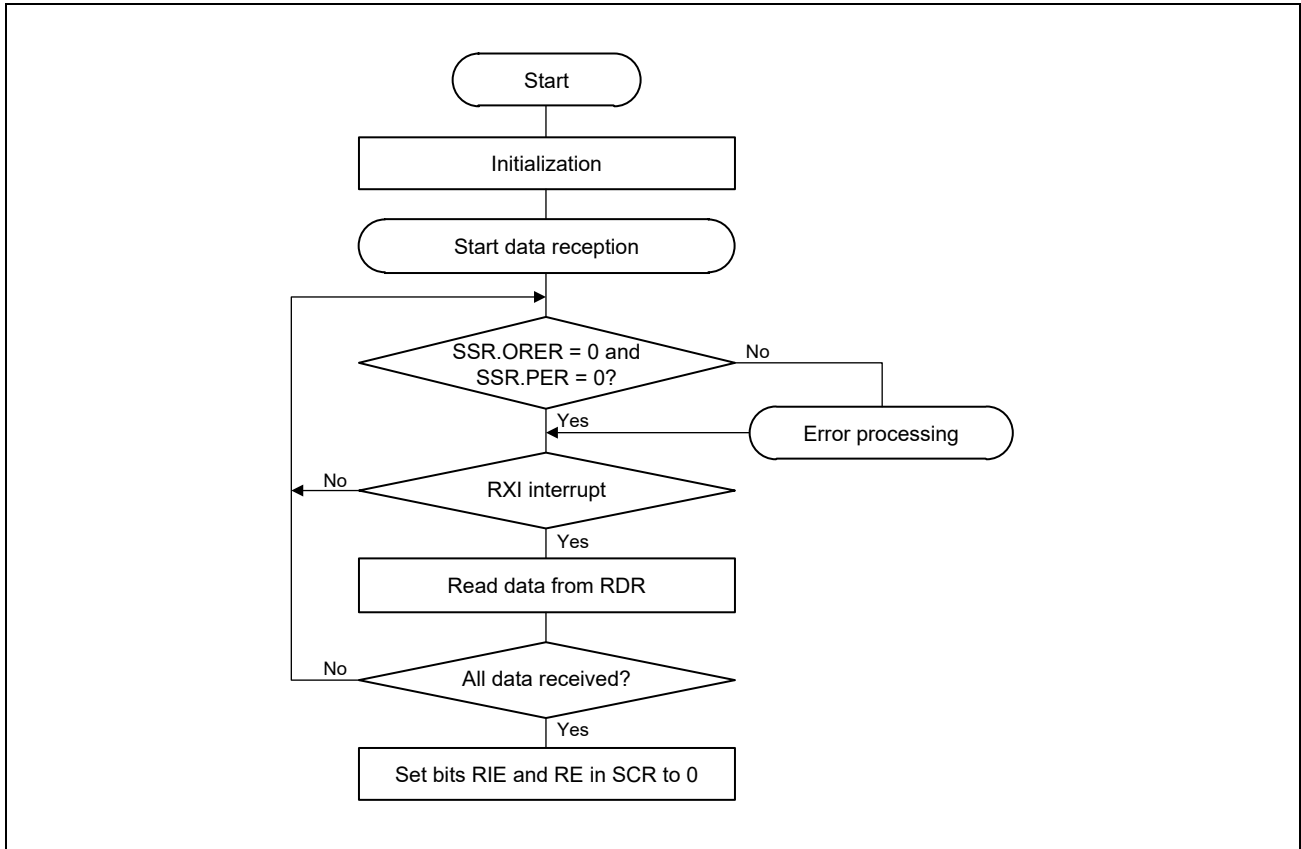

Figure 23.39 Sample Smart Card Interface Reception Flowchart

23.6.8 Clock Output Control

Clock output can be fixed using the `CKE[1:0]` bits in `SCR` when the `GM` bit in `SMR` is 1. Specifically, the minimum width of a clock pulse can be specified.

Figure 23.40 shows an example of clock output fixing timing when the `CKE[0]` bit is controlled with `GM = 1` and `CKE[1] = 0`.

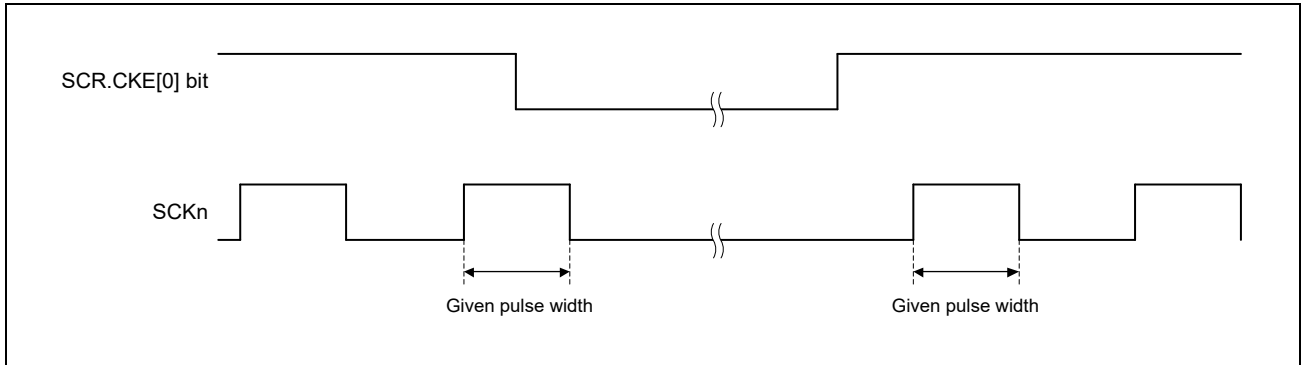

Figure 23.40 Clock Output Fixing Timing

At power-on, use the following procedure to secure the appropriate clock duty cycle.

(1) At Power-On

To secure the appropriate clock duty cycle simultaneously with power-on, use the following procedure.

1. Initially, port input is enabled in the high-impedance state. To fix the potential level, use a pull-up or pull-down resistor.
2. Fix the `SCKn` pin to the specified output by setting the `SCR.CKE[1]` bit and I/O port functions.
3. Set `SMR` and `SCMR` to enable smart card interface mode.
4. Set the `SCR.CKE[0]` bit to 1 to start clock output.

23.7 Noise Cancellation Function

Figure 23.41 shows the configuration of the noise filter used for noise cancellation. The noise filter consists of two stages of flip-flop circuits and a match-detection circuit. When the level on the pin matches in three consecutive samples taken at the set sampling interval, the matching level continues to be conveyed internally until the level on the pin again matches in three consecutive samples.

In asynchronous mode, the noise cancellation function can be applied on the RXDn input signal. The period of the base clock (1/16th of a bit-period when SEMR.ABCS = 0 and 1/8th of a bit-period when SEMR.ABCS = 1) is the sampling interval.

If the base clock is stopped with the noise filter enabled and then the clock input is started again, the noise filter operation resumes from where the clock was stopped. If SCR.TE and SCR.RE are set to 0 during base clock input, all of the noise filter flip-flop values are initialized to 1. Accordingly, if the input data is 1 when reception operation resumes, it is determined that a level match is detected and is conveyed to the internal signal. When the level being input corresponds to 0, the initial output of the noise filter is retained until the level matches in three consecutive samples.

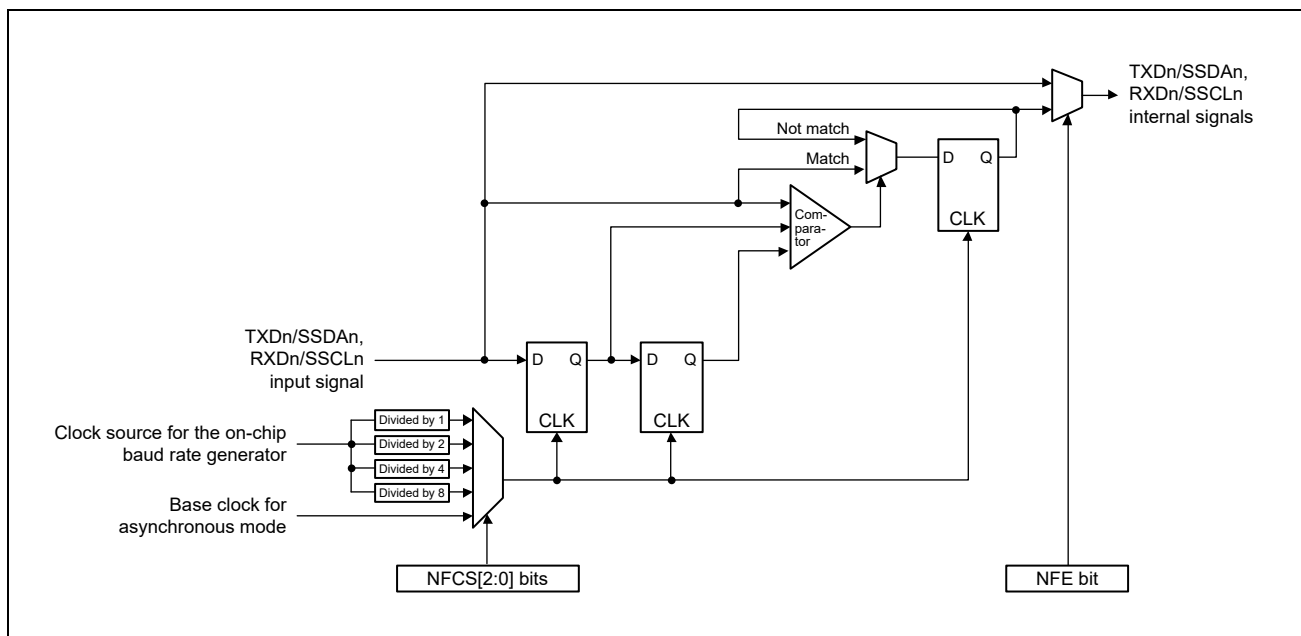

Figure 23.41 Block Diagram of Digital Noise Filter Circuit

23.8 Interrupt Sources

23.8.1 Buffer Operations for TXI and RXI Interrupts

If the conditions for a TXI and RXI interrupt are satisfied while the interrupt status flag in the interrupt controller is 1, the interrupt controller does not output the interrupt request but retains it internally (with a capacity for retention of one request per source).

When the value of the interrupt status flag in the interrupt controller becomes 0, the interrupt request retained within the interrupt controller is output. The internally retained interrupt request is automatically discarded once the actual interrupt is output. Clearing of the corresponding interrupt enable bit (the TIE or RIE bit in the SCR) can also be used to discard an internally retained interrupt request.

23.8.2 Interrupts in Asynchronous Mode and Clock Synchronous Mode

Table 23.20 lists interrupt sources in asynchronous mode and clock synchronous mode. A different interrupt vector is assigned to each interrupt source, and individual interrupt sources can be enabled or disabled with the enable bits in SCR. If the SCR.TIE bit is 1, a TXI interrupt request is generated when transmit data is transferred from the TDR or TDRL register*¹ to the TSR. A TXI interrupt request can also be generated by setting the SCR.TE bit to 1 after setting the SCR.TIE bit to 1 or by using a single instruction to set the SCR.TE and SCR.TIE bit to 1 at the same time. A TXI interrupt request can activate the DMAC to handle data transfer.

A TXI interrupt request is not generated by setting the SCR.TE bit to 1 while the setting of the SCR.TIE bit is 0 or by setting the SCR.TIE bit to 1 while the setting of the SCR.TE bit is 1.*¹

When new data is not written by the time of transmission of the last bit of the current transmit data and the setting of the SCR.TEIE bit is 1, the SSR.TEND flag becomes 1 and a TEI interrupt request is generated. Furthermore, when the setting of the SCR.TE bit is 1, the SSR.TEND flag retains the value 1 until further transmit data are written to the TDR or TDRL register*¹, and setting the SCR.TEIE bit to 1 leads to the generation of a TEI interrupt request.

Writing data to the TDR or TDRL register*¹ leads to clearing of the SSR.TEND flag and, after a certain time, discarding of the TEI interrupt request.

If the SCR.RIE bit is 1, an RXI interrupt request is generated when received data is stored in the RDR. An RXI interrupt request can activate the DMAC to handle data transfer.

Setting of any from among the ORER, FER, and PER flags in the SSR to 1 while the SCR.RIE bit is 1 leads to the generation of an ERI interrupt request. An RXI interrupt request is not generated at this time. Clearing all three flags (ORER, FER, and PER) leads to discarding of the ERI interrupt request.

Note 1. In the case where asynchronous mode and 9-bit data length are selected

NOTE

To temporarily prohibit TXI interrupts at the time of transmission of the last of the data and so on when you wish a new round of transmission to start after handling of the transmission-completed interrupt, control prohibiting and permitting of the interrupt by using the interrupt request enable bit in the interrupt controller rather than using the SCR.TIE bit. This can prevent the suppression of TXI interrupt requests in the transfer of new data.

Table 23.20 Interrupt Sources

Name	Interrupt Source	Interrupt Flag	DMAC Activation	Priority
ERI	Receive error	ORER, FER, or PER	Not possible	High
RXI	Receive data full	—	Possible	↑ Low
TXI	Transmit data empty	—	Possible	
TEI	Transmit end	TEND	Not possible	Low

23.8.3 Interrupts in Smart Card Interface Mode

Table 23.21 lists interrupt sources in smart card interface mode. A transmit end interrupt (TEI) request cannot be used in this mode.

Table 23.21 SCI Interrupt Sources

Name	Interrupt Source	Interrupt Flag	DMAC Activation	Priority
ERI	Receive error or error signal detection	ORER, PER, or ERS	Not possible	High
RXI	Receive data full	—	Possible	↑ Low
TXI	Transmit data empty	TEND	Possible	

Data transmission/reception using the DMAC is also possible in smart card interface mode, similar to in the normal SCI mode. In transmission, when the TEND flag in SSR is set to 1, a TXI interrupt request is generated. This TXI interrupt request activates the DMAC allowing transfer of transmit data if the TXI request is specified beforehand as a source of DMAC activation. The TEND flag is automatically set to 0 when the DMAC transfers the data.

If an error occurs, the SCI automatically retransmits the same data. During the retransmission, the TEND flag is kept to 0 and the DMAC is not activated. Therefore, the SCI and DMAC automatically transmit the specified number of bytes, including retransmission in the case of error occurrence. However, the ERS flag in SSR is not automatically cleared to 0 at error occurrence. Therefore, the ERS flag must be cleared by previously setting the RIE bit in SCR to 1 to enable an ERI interrupt request to be generated at error occurrence.

When transmitting/receiving data using the DMAC, be sure to make settings to enable the DMAC before making SCI settings. For DMAC settings, refer to **Section 14, Direct Memory Access Controller**.

In reception, an RXI interrupt request is generated when receive data is set to RDR. This RXI interrupt request activates the DMAC allowing transfer of receive data if the RXI request is specified beforehand as a source of DMAC activation. If an error occurs, the error flag is set. Therefore, the DMAC is not activated and an ERI interrupt request is issued to the CPU instead; the error flag must be cleared.

23.9 Usage Notes

23.9.1 Break Detection and Processing

When a framing error is detected, a break can be detected by reading the RXDn pin value directly. In a break, the input from the RXDn pin becomes all 0s, and so the FER flag in SSR is set to 1 (framing error has occurred), and the PER flag in SSR may also be set to 1 (parity error has occurred). The SCI continues the receive operation even after a break is received. Therefore, note that even if the FER flag is set to 0 (no framing error occurred), it will be set to 1 again.

When the SEMR.RXDESEL bit is 1, the SCI sets the SSR.FER flag to 1 and stops receiving operation until a start bit of the next data frame is detected. If the SSR.FER flag is set to 0 at this time, the SSR.FER flag retains 0 during the break.

When the RXDn pin is set to 1 and the break ends, detecting the beginning of the start bit at the first falling edge of the RXDn pin allows the SCI to start the receiving operation.

23.9.2 Mark State and Production of Breaks

When the SCR.TE bit is 0 (serial transmission is disabled), setting the I/O port function makes selection of the level and direction (input or output) of the TXDn pin possible. If this is done, the TXDn pin can be placed in the mark state to send a break at the time of data transmission. Until the SCR.TE bit is set to 1 (serial transmission is enabled), the I/O port function is used to set the TXDn pin to output 1 and set the pin mode to a general I/O port pin, and thus place the communication line in the mark state (state of having the value 1). On the other hand, to output a break at the time of data transmission, set the TXDn pin to output 0 and make the pin mode settings for a general I/O port pin. When the SCR.TE bit is set to 0, the transmitter is initialized regardless of the current state of transmission.

23.9.3 Receive Error Flags and Transmit Operations (Clock Synchronous Mode)

Transmission cannot be started when a receive error flag (ORER) in SSR is set to 1, even if data is written to TDR. Be sure to set the receive error flags to 0 before starting transmission. Note also that the receive error flags cannot be set to 0 even if the RE bit in SCR is set to 0 (serial reception is disabled).

23.9.4 Writing Data to TDR

Data can be written to TDR, TDRH, and TDRL. However, if new data is written to TDR, TDRH, and TDRL when transmit data is remaining in TDR, TDRH, and TDRL, the previous data in TDR, TDRH, and TDRL is lost because it has not been transferred to TSR yet. Be sure to write transmit data to TDR, TDRH, and TDRL in the TXI interrupt request handling routine.

23.9.5 Restrictions on Clock Synchronous Transmission (Clock Synchronous Mode)

When the external clock source is used as a synchronization clock, the following restrictions apply.

(1) Start of transmission

Update TDR by the CPU or DMAC and wait for at least five P0 ϕ cycles before allowing the transmit clock to be input (see **Figure 23.42**).

(2) Continuous transmission

- (a) Write the next transmit data to TDR or TDRL before the falling edge of the transmit clock (bit 7) (see **Figure 23.42**).
- (b) When updating TDR after bit 7 has started to transmit, update TDR while the synchronization clock is in the low-level period, and set the high-level width of the transmit clock (bit 7) to four P0 ϕ cycles or longer (see **Figure 23.42**).

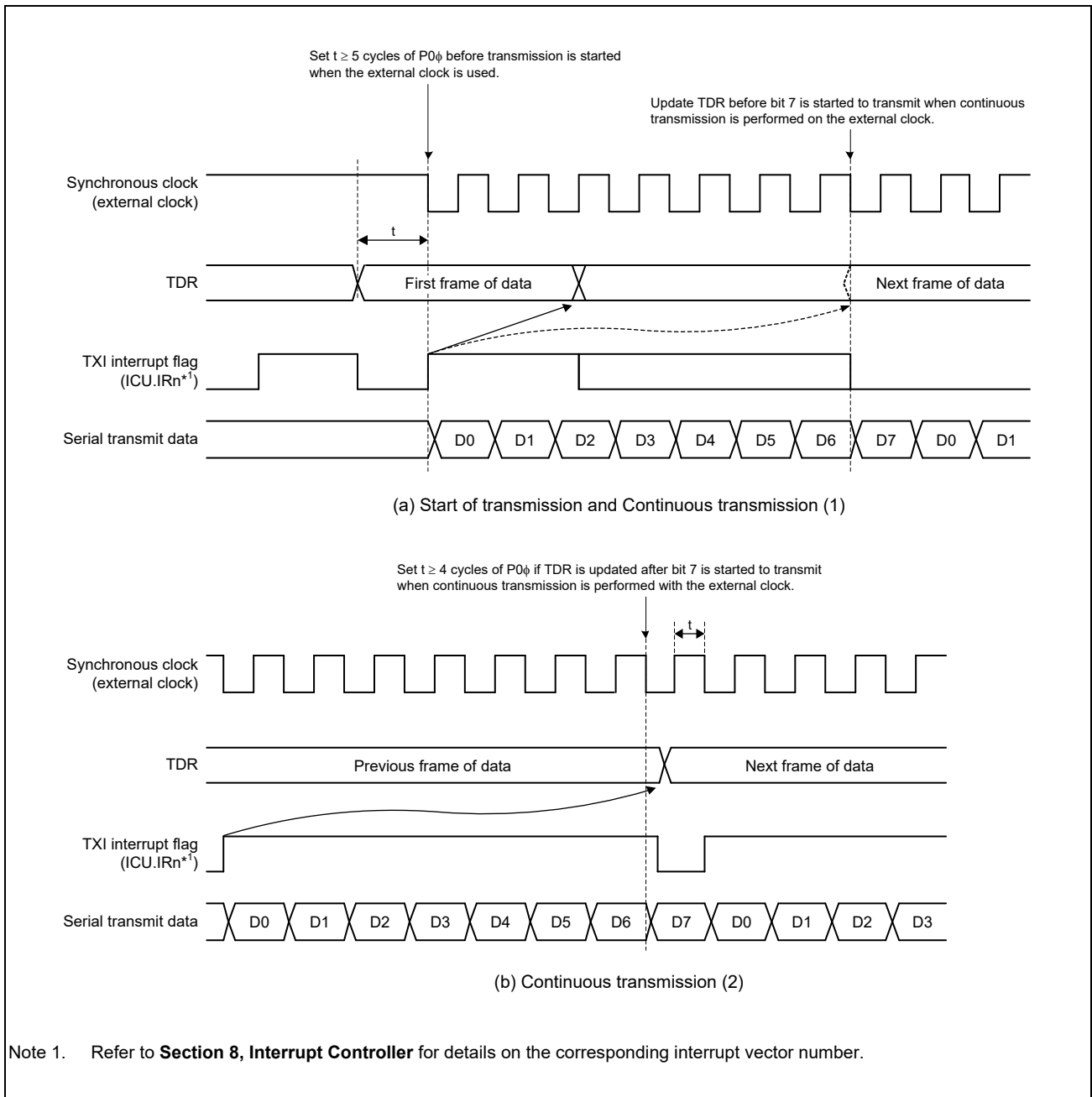

Figure 23.42 Restrictions on Use of External Clock in Clock Synchronous Transmission

23.9.6 Restrictions on Using DMAC

When using the DMAC or DTC to read RDR, RDRH, and RDRL, be sure to set the receive data full interrupt (RXI) as the activation source of the relevant SCI.

23.9.7 Notes on Starting Transfer

At the point where transfer starts when the interrupt status flag (IRn.IR bit) in the interrupt controller is 1, follow the procedure below to clear interrupt requests before permitting operations (by setting the SCR.TE or SCR.RE bit to 1). For details on the interrupt status flag, refer to **Section 8, Interrupt Controller**.

- Confirm that transfer has stopped (the setting of the SCR.TE or SCR.RE bits is 0).
- Set the corresponding interrupt enable bit (SCR.TIE or SCR.RIE) to 0.
- Read the corresponding interrupt enable bit (SCR.TIE or SCR.RIE bit) to check that it has become 0.
- Set the interrupt status flag (IRn.IR bit) in the interrupt controller to 0.

23.9.8 External Clock Input in Clock Synchronous Mode

In clock synchronous mode, the external clock SCKn must be input as follows:

High-pulse period, low-pulse period = 2 P0φ cycles or more, period = 6 P0φ cycles or more

23.9.9 Note on Transmit Enable Bit (TE bit)

When setting the SCR.TE bit to 0 (serial transmission is disabled) while the pin function is “TXDn”, output of the pin becomes high impedance.

Prevent the TXDn line from becoming high impedance by any of the following ways:

- (1) Connect a pull-up resistor to the TXDn line.
- (2) Change the pin function to “general-purpose I/O port, output” before setting the SCR.TE bit to 0. Set the SCR.TE bit to 1 before changing the pin function to “TXDn”.

23.10 IrDA Communications

The channel 0 serial communications interface (SCI) is capable of working with the Infrared Data Association (IrDA) module to handle transfer through IrDA communications in conformance with version 1.0 of the IrDA protocol.

Using the IRE bit in IRCR to enable the IrDA function leads to encoding and decoding of the SCI0_TXD and SCI0_RXD signals of the channel 0 serial communications interface, respectively, to convert them to and from waveforms in conformance with version 1.0 of the IrDA protocol. Infrared transfer in conformance with version 1.0 of the IrDA protocol can be handled by connecting a transceiver for use in infrared communications.

In version 1.0 of the IrDA protocol, IrDA transfer starts at a transfer rate of 9600 bps. The transfer rate is changeable during transfer as required. The IrDA module itself does not have a function for automatically changing the transfer rate. Accordingly, change the transfer rate by changing that for the serial communications interface.

A block diagram and pin configuration for IrDA transfer are shown in **Figure 23.43** and **Table 23.22**, respectively.

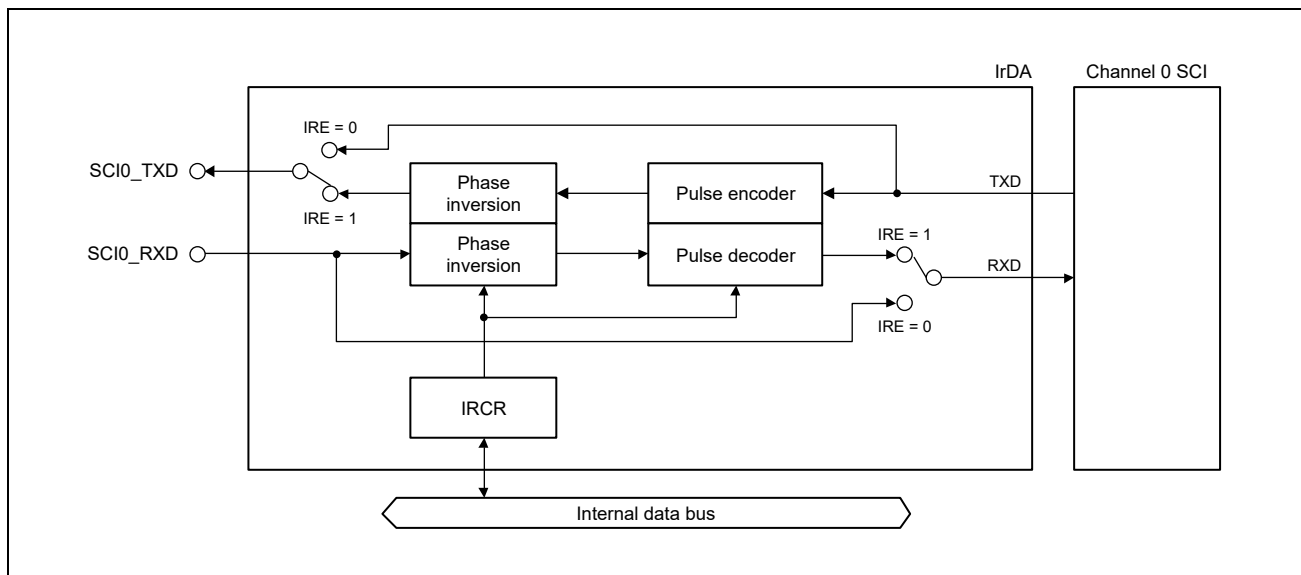

Figure 23.43 Block Diagram

Table 23.22 Pin Configuration

Pin Name	Symbol	I/O	Function
IrDA data transmission pin	SCI0_TXD	Output	IrDA data transmission output
IrDA data reception pin	SCI0_RXD	Input	IrDA data reception input

23.11 Description of the IrDA Register

Table 23.23 shows the register configuration.

BASE Address (AX45MP Address Space): H'0_1004_CC00

Table 23.23 Register Configuration

Register Name	Abbreviation	R/W	Initial Value	Address	Access Size
IrDA Control Register	IRCR	R/W	H'00	H'0_1004_CC00	8

23.11.1 IrDA Control Register (IRCR)

IRCR sets the operation of the IrDA module.

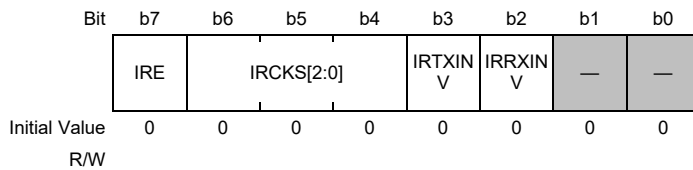

Bit	Bit Name	Initial Value	R/W	Description
b1, b0	—		R	Reserved These bits are read as 0. The write value should be 0.
b2	IRRXINV		R/W	SCI_RXD0 Data Level Switching Sets inversion of the logic level of inputs on SCI0_RXD. 0: The input on SCI0_RXD is used without change as the received data. 1: The input on SCI0_RXD is inverted before it is treated as the received data.
b3	IRTXINV		R/W	SCI_TXD0 Data Level Switching Sets inversion of the logic level of outputs on SCI0_TXD. 0: Data for transmission is output without change to SCI0_TXD. The pulse-width setting in the IRCKS bits determines the period over which the pulses are at the high level. 1: Data for transmission is inverted before being output to SCI0_TXD. The pulse-width setting in the IRCKS bits determines the period over which the pulses are at the low level.
b6 to b4	IRCKS[2:0]		R/W	IrDA Clock Select Selects the pulse width for use in encoding output pulses from SCI0_TXD when the setting of the IRE bit is 1. 000: Bit rate × 3/16 Settings other than above are prohibited.
b7	IRE		R/W	IrDA Enable Sets the function for use with the SCI0_TXD and SCI0_RXD pins as normal serial or IrDA. 0: Disables the IrDA function. Data from the TXD pin of the channel 0 serial communications interface is output without change to SCI0_TXD. Data on SCI0_RXD is output without change to the RXD pin of the channel 0 serial communications interface. 1: Enables the IrDA function. Data from the TXD pin of the channel 0 serial communications interface is encoded before being output through SCI0_TXD. Data on SCI0_RXD is decoded before being output to the RXD pin of the channel 0 serial communications interface.

23.12 IrDA Operation

23.12.1 Flow of Settings for IrDA Operation

Set up IrDA operation by following the procedure listed below.

1. Make the general-purpose I/O port-pin settings.
2. Set the IRCR register.
3. Set the registers related to the serial communications interface.

23.12.2 Transmission

In transmission with the IrDA function enabled, serial data (UART frames of data) from the TXD pin of the serial communications interface are converted to IR frames (see **Figure 23.44**). If the IRTXINV bit is set to 0, when the value of the serial data is 0, a high-level pulse with the width equivalent to three sixteenths of the bit period is output to the SCI0_TXD pin by default. In the IrDA protocol, the specifiable high-level pulse widths are from a minimum of 1.41 μs to a maximum of $(3/16 + 2.5\%) \times \text{bit period}$ or $(3/16 \times \text{bit period}) + 1.08 \mu\text{s}$. On the other hand, if the value of the serial data is 1, no high-level pulse is output.

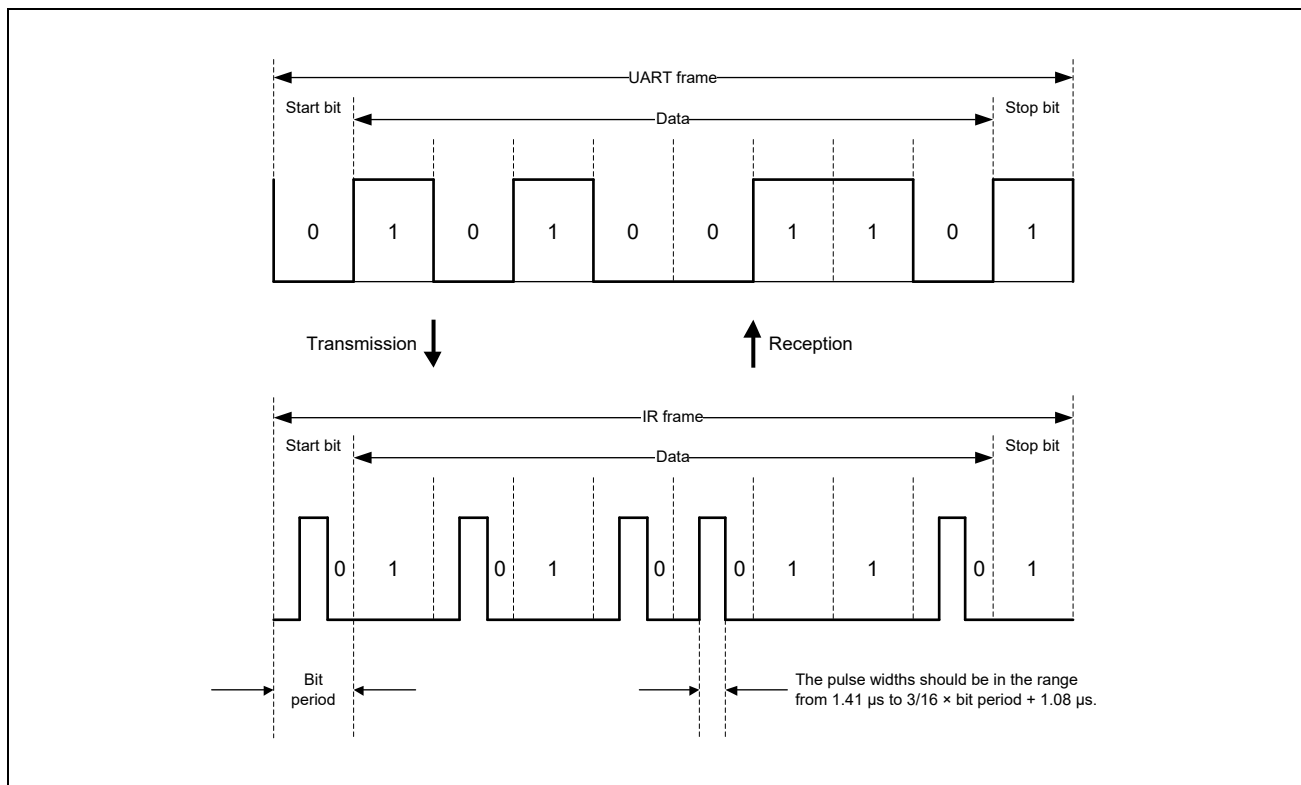

Figure 23.44 Example of the Operation in IrDA Transfer

23.12.3 Reception

In reception with the IrDA function enabled, IR frames of data from the SCIO_RXD pin are converted to serial data and output to the RXD pin of the serial communications interface. If the setting of the IRRXINV bit is 0, the value 0 is output when a high-level pulse is detected and the value 1 is output when no high-level pulse is detected during each bit period. Note that pulses with a width shorter than the minimum pulse width of 1.41 μ s cannot be recognized.

23.12.4 Relationship between Bit Rate and High-Level Pulse Width

The relationship between the Bit Rate during transmission and the High-Level Pulse is shown in **Table 23.24**.

Table 23.24 Upper Row: Bit Rate (bps); Lower Row: Bit Period \times 3/16 (μ s)

2400	9600	19200	38400	57600	115200
78.13	19.53	9.77	4.88	3.26	1.63

23.13 Note on IrDA Usage

23.13.1 Minimum Pulse Width in Reception

Pulses with a width shorter than the minimum pulse width of 1.41 μs cannot be recognized

23.13.2 Base Clock in Asynchronous Mode for the Serial Communications Interface

The IrDA module works with the serial communications interface by receiving the base clock with a frequency 16 times the bit rate for communications from the interface. For the serial communications interface, either 16 or 8 cycles of the base clock are selectable as the bit period. On the other hand, the IrDA module is only capable of operation when the setting for the bit period of the serial communications interface is 16 cycles of the base clock.

24. Renesas Serial Peripheral Interface

This LSI circuit includes three independent Renesas serial peripheral interfaces.

This module is capable of full-duplex synchronous serial communication.

24.1.1 Features

This module has the following features.

SPI transfer functions

- Use of MOSI (master out/slave in), MISO (master in/slave out), SSL (slave select), and RSPCK (SPI clock) signals allows for serial communications through SPI operation (four-wire method).
- Capable of serial communications in master/slave mode
- Supports mode fault error detection (only in SPI slave mode)
- Supports overrun error detection (only in SPI slave mode)
- Switching of the polarity of the serial transfer clock
- Switching of the clock phase of serial transfer

Data format

- MSB-first/LSB-first selectable
- Transfer bit-length is selectable as 8, 16, or 32 bits.

Bit rate

- RSPCK can be divided by a maximum of 4096 in master mode
- RSPCK can be generated by dividing P0 ϕ by the on-chip baud rate generator.
- An externally input clock can be used as a serial clock.

Buffer configuration

- 8 bytes for transmission and 32 bytes for reception

SSL control function

- One SSL signal for each channel
 - In master mode, outputs SSL signal.
 - In slave mode, inputs SSL signal.
- Controllable delay from SSL output assertion to RSPCK operation (RSPCK delay)
 - Range: 1 to 8 RSPCK cycles (set in RSPCK-cycle units)
- Controllable delay from RSPCK stoppage to SSL output negation (SSL negation delay)
 - Range: 1 to 8 RSPCK cycles (set in RSPCK-cycle units)
- Controllable wait for next-access SSL output assertion (next-access delay)
 - Range: 1 to 8 RSPCK cycles (set in RSPCK-cycle units)
- Function for changing SSL polarity

Control in master transfer

- A transfer of up to four commands can be executed sequentially in looped execution.
- For each command, the following can be set:
 - SSL signal value, bit rate, RSPCK polarity/phase, transfer data length, LSB/MSB first, burst, RSPCK delay, SSL negation delay, and next-access delay.
 - A transfer can be initiated by writing to the transmit buffer.
 - A transfer can be initiated by clearing the SPTEF bit.
 - MOSI signal value specifiable in SSL negation

Interrupt sources

- Maskable interrupt sources:
 - Receive interrupt (receive buffer full)
 - Transmit interrupt (transmit buffer empty)
 - Error interrupt (mode fault, overrun)

Others

- Provides loop back mode
- Provides a function for disabling (initializing) this module

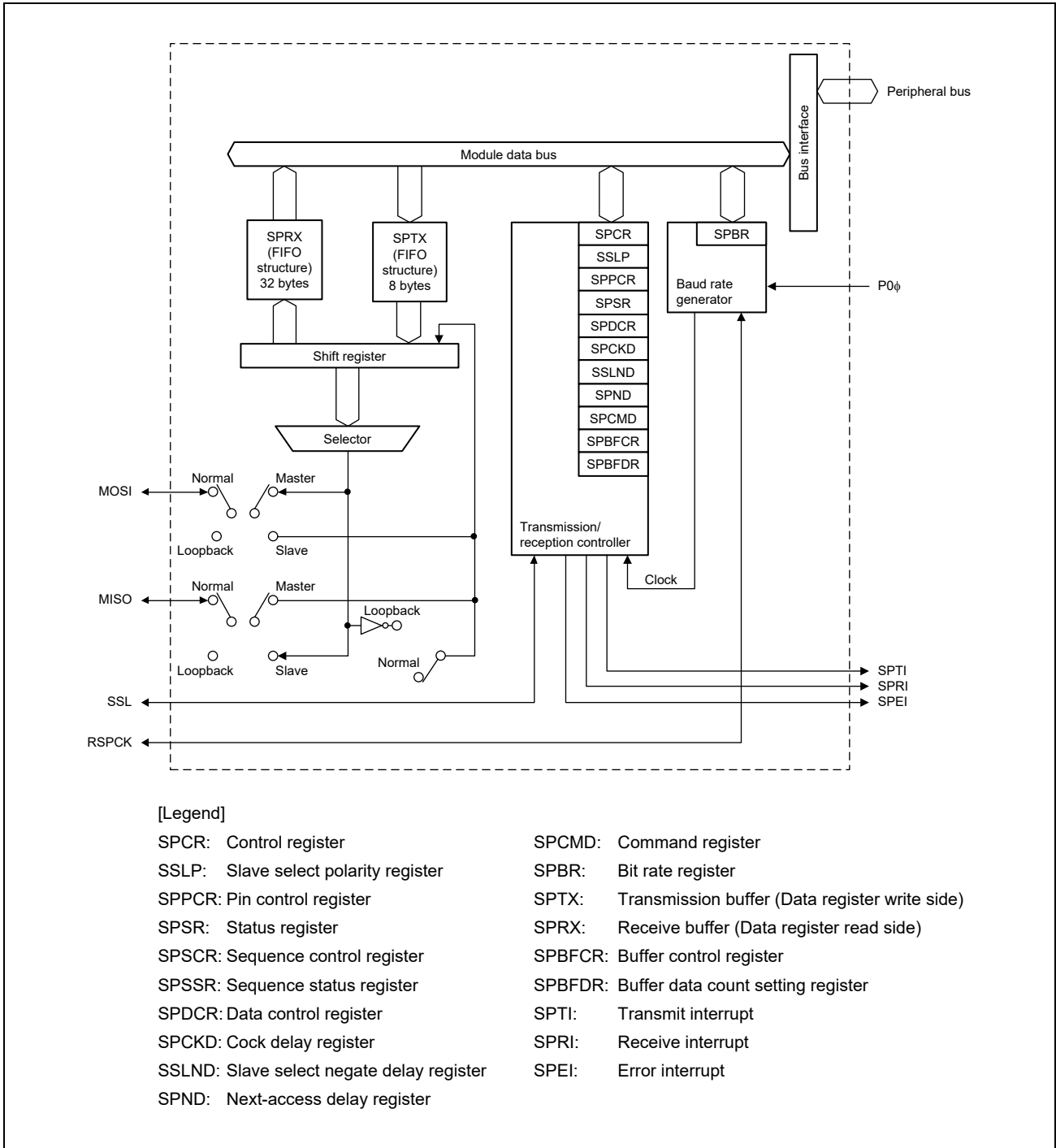

Figure 24.1 Block Diagram (for One Channel)

24.2 Input/Output Pins

Table 24.1 shows the pin configuration. This module automatically switches the input/output direction of the SSL pin. SSL is set as an output in master mode and as an input in slave mode. Pins RSPCK, MOSI, and MISO are automatically set as inputs or outputs according to the setting of master or slave and the level input on SSL (see **Section 24.4.2, Pin Control**).

Table 24.1 Pin Configuration

Channel	Pin Name	Pin Name	I/O	Function
0	Clock pin	RSPI0_CK	I/O	Clock input/output
	Master transmit data pin	RSPI0_MOSI	I/O	Master transmit data
	Slave transmit data pin	RSPI0_MISO	I/O	Slave transmit data
	Slave select 0 pin	RSPI0_SSL	I/O	Slave selection
1	Clock pin	RSPI1_CK	I/O	Clock input/output
	Master transmit data pin	RSPI1_MOSI	I/O	Master transmit data
	Slave transmit data pin	RSPI1_MISO	I/O	Slave transmit data
	Slave select 0 pin	RSPI1_SSL	I/O	Slave selection
2	Clock pin	RSPI2_CK	I/O	Clock input/output
	Master transmit data pin	RSPI2_MOSI	I/O	Master transmit data
	Slave transmit data pin	RSPI2_MISO	I/O	Slave transmit data
	Slave select 0 pin	RSPI2_SSL	I/O	Slave selection

Note: In the description of the pins, the channel is omitted, and pin names are described as RSPCK, MOSI, MISO, and SSL.

24.3 Register Descriptions

Table 24.2 shows the register configuration. The address of the RSPI register is represented by the offset address from the base address. RSPI base address is as follows:

Base address: H'0_1004_0000 (Overall Address Space)

Table 24.2 Register Configuration (1/2)

Channel	Register Name	Abbreviation*1	R/W	Initial Value	Offset Address	Access Size
0	Control register_0	SPCR_0	R/W	H'00	H'AC00	8
	Slave select polarity register_0	SSLP_0	R/W	H'00	H'AC01	8
	Pin control register_0	SPPCR_0	R/W	H'00	H'AC02	8
	Status register_0	SPSR_0	R/(W)*2	H'60	H'AC03	8
	Data register_0	SPDR_0	R/W	Undefined	H'AC04	8, 16, 32
	Sequence control register_0	SPSCR_0	R/W	H'00	H'AC08	8
	Sequence status register_0	SPSSR_0	R	H'00	H'AC09	8
	Bit rate register_0	SPBR_0	R/W	H'FF	H'AC0A	8
	Data control register_0	SPDCR_0	R/W	H'20	H'AC0B	8
	Clock delay register_0	SPCKD_0	R/W	H'00	H'AC0C	8
	Slave select negation delay register_0	SSLND_0	R/W	H'00	H'AC0D	8
	Next-access delay register_0	SPND_0	R/W	H'00	H'AC0E	8
	Command register0_0	SPCMD0_0	R/W	H'070D	H'AC10	16
	Command register1_0	SPCMD1_0	R/W	H'070D	H'AC12	16
	Command register2_0	SPCMD2_0	R/W	H'070D	H'AC14	16
	Command register3_0	SPCMD3_0	R/W	H'070D	H'AC16	16
	Buffer control register_0	SPBFCR_0	R/W	H'00	H'AC20	8
Buffer data count setting register_0	SPBFDR_0	R	H'0000	H'AC22	16	
1	Control register_1	SPCR_1	R/W	H'00	H'B000	8
	Slave select polarity register_1	SSLP_1	R/W	H'00	H'B001	8
	Pin control register_1	SPPCR_1	R/W	H'00	H'B002	8
	Status register_1	SPSR_1	R/(W)*2	H'60	H'B003	8
	Data register_1	SPDR_1	R/W	Undefined	H'B004	8, 16, 32
	Sequence control register_1	SPSCR_1	R/W	H'00	H'B008	8
	Sequence status register_1	SPSSR_1	R	H'00	H'B009	8
	Bit rate register_1	SPBR_1	R/W	H'FF	H'B00A	8
	Data control register_1	SPDCR_1	R/W	H'20	H'B00B	8
	Clock delay register_1	SPCKD_1	R/W	H'00	H'B00C	8
	Slave select negation delay register_1	SSLND_1	R/W	H'00	H'B00D	8
	Next-access delay register_1	SPND_1	R/W	H'00	H'B00E	8
	Command register0_1	SPCMD0_1	R/W	H'070D	H'B010	16
	Command register1_1	SPCMD1_1	R/W	H'070D	H'B012	16
	Command register2_1	SPCMD2_1	R/W	H'070D	H'B014	16
	Command register3_1	SPCMD3_1	R/W	H'070D	H'B016	16
	Buffer control register_1	SPBFCR_1	R/W	H'00	H'B020	8
Buffer data count setting register_1	SPBFDR_1	R	H'0000	H'B022	16	

Table 24.2 Register Configuration (2/2)

Channel	Register Name	Abbreviation* ¹	R/W	Initial Value	Offset Address	Access Size
2	Control register_2	SPCR_2	R/W	H'00	H'B400	8
	Slave select polarity register_2	SSLP_2	R/W	H'00	H'B401	8
	Pin control register_2	SPPCR_2	R/W	H'00	H'B402	8
	Status register_2	SPSR_2	R/(W)* ²	H'60	H'B403	8
	Data register_2	SPDR_2	R/W	Undefined	H'B404	8, 16, 32
	Sequence control register_2	SPSCR_2	R/W	H'00	H'B408	8
	Sequence status register_2	SPSSR_2	R	H'00	H'B409	8
	Bit rate register_2	SPBR_2	R/W	H'FF	H'B40A	8
	Data control register_2	SPDCR_2	R/W	H'20	H'B40B	8
	Clock delay register_2	SPCKD_2	R/W	H'00	H'B40C	8
	Slave select negation delay register_2	SSLND_2	R/W	H'00	H'B40D	8
	Next-access delay register_2	SPND_2	R/W	H'00	H'B40E	8
	Command register0_2	SPCMD0_2	R/W	H'070D	H'B410	16
	Command register1_2	SPCMD1_2	R/W	H'070D	H'B412	16
	Command register2_2	SPCMD2_2	R/W	H'070D	H'B414	16
	Command register3_2	SPCMD3_2	R/W	H'070D	H'B416	16
	Buffer control register_2	SPBFCR_2	R/W	H'00	H'B420	8
	Buffer data count setting register_2	SPBFDR_2	R	H'0000	H'B422	16

Note 1. In the description of the register names, the channel is omitted.

Note 2. Only 0 can be written to clear the flag.

24.3.1 Control Register (SPCR)

SPCR sets the operating mode. If the MSTR and MODFEN bits are changed while the function of this module is enabled by setting the SPE bit to 1, subsequent operations cannot be guaranteed.

Bit	7	6	5	4	3	2	1	0
	SPRIE	SPE	SPTIE	SPEIE	MSTR	MODFEN	—	—
Initial Value	0	0	0	0	0	0	0	0
R/W	R/W	R/W	R/W	R/W	R/W	R/W	R	R

Bit	Bit Name	Initial Value	R/W	Description
7	SPRIE	0	R/W	Receive Interrupt Enable Enables or disables generation of receive interrupt requests (SPRI) when the number of receive data units in the receive buffer (SPRX) is equal to or greater than the specified receive buffer data triggering number and the SPRF flag in SPSR is set to 1. 0: Disables the generation of receive interrupt requests. 1: Enables the generation of receive interrupt requests.
6	SPE	0	R/W	Function Enable Setting this bit to 1 enables the module function. When the MODF bit in the status register (SPSR) is 1, the SPE bit cannot be set to 1 (see Section 24.4.6, Error Detection). Setting the SPE bit to 0 disables the module function, and initializes a part of the module function (see Section 24.4.7, Initialization). 0: Disables the module function. 1: Enables the module function.
5	SPTIE	0	R/W	Transmit Interrupt Enable Enables or disables generation of transmit interrupt requests (SPTI) when the number of transmit data units in the transmit buffer (SPTX) is equal to or less than the specified transmit buffer data triggering number and the SPTEF flag in SPSR is set to 1. 0: Disables the generation of transmit interrupt requests. 1: Enables the generation of transmit interrupt requests.
4	SPEIE	0	R/W	Error Interrupt Enable Enables or disables the generation of error interrupt requests when this module detects a mode fault error and sets the MODF bit in the status register (SPSR) to 1, or when this module detects an overrun error and sets the OVRF bit in SPSR to 1 (see Section 24.4.6, Error Detection). 0: Disables the generation of error interrupt requests. 1: Enables the generation of error interrupt requests. <i>Note:</i> This bit is valid only in SPI slave mode.
3	MSTR	0	R/W	Master/Slave Mode Select Selects master/slave mode. According to MSTR bit settings, this module determines the direction of the RSPCK, MOSI, MISO, and SSL pins. 0: Slave mode 1: Master mode
2	MODFEN	0	R/W	Mode Fault Error Detection Enable Enables or disables the detection of a mode fault error (see Section 24.4.6, Error Detection). 0: Disables the detection of a mode fault error. 1: Enables the detection of a mode fault error. <i>Note:</i> This bit is valid only in SPI slave mode. When master mode is specified with the MSTR bit, this bit should always be cleared to 0.
1, 0	—	All 0	R	Reserved The write value should always be 0. Otherwise, operation cannot be guaranteed.

24.3.2 Slave Select Polarity Register (SSLP)

SSLP sets the polarity of the SSL signal. If the contents of SSL0P are changed while the function of this module is enabled by setting the SPE bit in the control register (SPCR) to 1, subsequent operations cannot be guaranteed.

Bit	7	6	5	4	3	2	1	0
	—	—	—	—	—	—	—	SSL0P
Initial Value	0	0	0	0	0	0	0	0
R/W	R	R	R	R	R	R	R	R/W

Bit	Bit Name	Initial Value	R/W	Description
7 to 1	—	All 0	R	Reserved The write value should always be 0. Otherwise, operation cannot be guaranteed.
0	SSL0P	0	R/W	SSL Signal Polarity Setting Sets the polarity of the SSL signal. The value of SSL0P indicates the active polarity of the SSL signal. 0: SSL signal 0-active 1: SSL signal 1-active

24.3.3 Pin Control Register (SPPCR)

SPPCR sets the modes of the pins. If the contents of this register are changed while the function of this module is enabled by setting the SPE bit in the control register (SPCR) to 1, subsequent operations cannot be guaranteed.

Bit	7	6	5	4	3	2	1	0
	—	—	MOIFE	MOIFV	—	—	—	SPLP
Initial Value	0	0	0	0	0	0	0	0
R/W	R	R	R/W	R/W	R	R	R	R/W

Bit	Bit Name	Initial Value	R/W	Description
7, 6	—	All 0	R	Reserved The write value should always be 0. Otherwise, operation cannot be guaranteed.
5	MOIFE	0	R/W	MOSI Idle Value Fixing Enable Fixes the MOSI output value when this module in master mode is in an SSL negation period (including the SSL retention period during a burst transfer). When MOIFE is 0, this module outputs the last output value from the previous serial transfer during the SSL negation period to the MOSI pin. (The value is undefined when CPHA is 0). When MOIFE is 1, this module outputs the fixed value set in the MOIFV bit to the MOSI pin. 0: MOSI output value equals the last output value from previous transfer. (The value is undefined when CPHA is 0). 1: MOSI output value equals the value set in the MOIFV bit.
4	MOIFV	0	R/W	MOSI Idle Fixed Value If the MOIFE bit is 1 in master mode, this module, according to MOIFV bit settings, determines the MOSI signal value during the SSL negation period (including the SSL retention period during a burst transfer). 0: MOSI Idle fixed value equals 0. 1: MOSI Idle fixed value equals 1.
3 to 1	—	All 0	R	Reserved The write value should always be 0. Otherwise, operation cannot be guaranteed.
0	SPLP	0	R/W	Loopback When the SPLP bit is set to 1, this module shuts off the path between the MISO pin and the shift register, and between the MOSI pin and the shift register, and connects (reverses) the input path and the output path for the shift register. 0: Normal mode 1: Loopback mode

24.3.4 Status Register (SPSR)

SPSR indicates the operating status.

Bit	7	6	5	4	3	2	1	0
	SPRF	TEND	SPTEF	—	—	MODF	—	OVRF
Initial Value	0	1	1	0	0	0	0	0
R/W	R	R	R	R	R	R/(W)*1	R	R/(W)*1

Note 1. Only 0 can be written to clear the flag after reading 1.

Bit	Bit Name	Initial Value	R/W	Description
7	SPRF	0	R	<p>Receive Buffer Full Flag</p> <p>Indicates that the number of receive data units in the receive buffer (SPRX) is equal to or greater than the receive buffer data triggering number specified in the buffer control register (SPBFCR).</p> <p>0: The number of receive data units in the receive buffer is less than the receive buffer data triggering number.</p> <p>1: The number of receive data units in the receive buffer is equal to or greater than the receive buffer data triggering number.</p> <p>[Clearing conditions]</p> <ul style="list-style-type: none"> The receive buffer data is read until the number of data units in the receive buffer becomes less than the specified receive buffer data triggering number. Receive buffer data reset is enabled. Power-on reset <p>[Setting condition]</p> <ul style="list-style-type: none"> The number of data units in the receive buffer is equal to or greater than the specified receive buffer data triggering number.
6	TEND	1	R	<p>Transmit End</p> <p>This bit is set to 1 when transmission is completed, and this bit is 0 when transmission is not completed.</p> <p>[Clearing condition]</p> <ul style="list-style-type: none"> When transmit data are transferred from the transmit register to the shift register. <p>[Setting condition]</p> <ul style="list-style-type: none"> When the number of data units in the transmit buffer (SPTX) is zero when a serial transfer is completed. <p><i>Note:</i> This bit is valid only in SPI master mode.</p>
5	SPTEF	1	R	<p>Transmit Buffer Empty Flag</p> <p>Indicates that the number of transmit data units in the transmit buffer (SPTX) is equal to or less than the transmit buffer data triggering number specified in the buffer control register (SPBFCR).</p> <p>0: The number of transmit data units in the transmit buffer is equal to or greater than the specified transmit buffer data triggering number.</p> <p>1: The number of transmit data units in the transmit buffer is less than the specified transmit buffer data triggering number.</p> <p>[Clearing condition]</p> <ul style="list-style-type: none"> When data is written to the transmit buffer until the number of transmit data units in the transmit buffer exceeds the specified transmit buffer data triggering number. <p>[Setting conditions]</p> <ul style="list-style-type: none"> When the number of transmit data units in the transmit buffer is less than the specified transmit buffer data triggering number. When transmit buffer data reset is enabled. Power-on reset
4, 3	—	All 0	R	<p>Reserved</p> <p>The write value should always be 0. Otherwise, operation cannot be guaranteed.</p>

Bit	Bit Name	Initial Value	R/W	Description
2	MODF	0	R/(W) *1	<p>Mode Fault Error Flag</p> <p>Indicates the occurrence of a mode fault error. If the MODFEN bit is set to 1 when this module is in slave mode and the SSL pin is negated before the RSPCK cycle necessary for data transfer ends, this module detects a mode fault error. The active level of the SSL signal is determined by the SSL0P bit in the slave select polarity register (SSLP).</p> <p>[Clearing conditions]</p> <ul style="list-style-type: none"> • SPSR is read when the MODF bit is 1, and then 0 is written to the MODF bit. • Power-on reset <p>0: No mode fault error occurred 1: A mode fault error occurred</p> <p><i>Note:</i> This bit is valid only in SPI slave mode.</p>
1	—	0	R	<p>Reserved</p> <p>The write value should always be 0. Otherwise, operation cannot be guaranteed.</p>
0	OVRF	0	R/(W) *1	<p>Overrun Error Flag</p> <p>Indicates the occurrence of an overrun error. If a serial transfer ends when there is not enough space for receiving the specified length of data in the receive buffer (SPRX), this module detects an overrun error, and sets the OVRF bit to 1.</p> <p>[Clearing conditions]</p> <ul style="list-style-type: none"> • SPSR is read when the OVRF bit is 1, and then 0 is written to the OVRF bit. • Power-on reset <p>0: No overrun error occurred 1: An overrun error occurred</p> <p><i>Note:</i> This bit is valid only in SPI slave mode.</p>

Note 1. Only 0 can be written to clear the flag after reading 1.

24.3.5 Data Register (SPDR)

SPDR is a buffer that holds data for transmission and reception.

The transmit buffer (SPTX) and receive buffer (SPRX) are independent and are mapped to SPDR.

SPDR should be read or written to in byte, word, or longword units according to the access width specification bit (SPLW) in the data control register (SPDCR).

The bit length to be used is determined by the data length specification bits (SPB3 to SPB0) in the command register (SPCMD).

The access width set by SPDCR must agree with the data length set by SPCMD.

When data is written to SPDR, the data will be written to the transmit buffer from SPDR if the transmit buffer has a space equal to or more than the SPDR access width. If there is not enough space, data will not be written to the transmit buffer. Even if an attempt is made to write data to the buffer, the data is ignored.

When data is read from SPDR, receive data in the receive buffer will be read. If SPDR is read when there is no receive data in the receive buffer, the read value is undefined.

When SPDR is written to with the longword-, word-, or byte-access width, the transmit data should be written to address 0 irrespective of the access width. If data is written to the other addresses, the data is not guaranteed.

When SPDR is read with the longword-, word-, or byte-access width, the receive data should be read from address 0. If data is read from the other addresses, the data is not guaranteed.

Bit	31	30	29	28	27	26	25	24	23	22	21	20	19	18	17	16
	SPD31	SPD30	SPD29	SPD28	SPD27	SPD26	SPD25	SPD24	SPD23	SPD22	SPD21	SPD20	SPD19	SPD18	SPD17	SPD16
Initial Value	Undefined	Undefined	Undefined	Undefined	Undefined	Undefined	Undefined	Undefined	Undefined	Undefined	Undefined	Undefined	Undefined	Undefined	Undefined	Undefined
R/W	R/W	R/W	R/W	R/W	R/W	R/W	R/W	R/W	R/W	R/W	R/W	R/W	R/W	R/W	R/W	R/W
Bit	15	14	13	12	11	10	9	8	7	6	5	4	3	2	1	0
	SPD15	SPD14	SPD13	SPD12	SPD11	SPD10	SPD9	SPD8	SPD7	SPD6	SPD5	SPD4	SPD3	SPD2	SPD1	SPD0
Initial Value	Undefined	Undefined	Undefined	Undefined	Undefined	Undefined	Undefined	Undefined	Undefined	Undefined	Undefined	Undefined	Undefined	Undefined	Undefined	Undefined
R/W	R/W	R/W	R/W	R/W	R/W	R/W	R/W	R/W	R/W	R/W	R/W	R/W	R/W	R/W	R/W	R/W

24.3.6 Sequence Control Register (SPSCR)

SPSCR sets the sequence control method when this module operates in master mode. If the contents of SPSCR are changed while the MSTR and SPE bits in the control register (SPCR) are 1 with the function of this module enabled in master mode, the subsequent operation cannot be guaranteed.

Bit	7	6	5	4	3	2	1	0
	—	—	—	—	—	—	SPSLN1	SPSLN0
Initial Value	0	0	0	0	0	0	0	0
R/W	R	R	R	R	R	R	R/W	R/W

Bit	Bit Name	Initial Value	R/W	Description
7 to 2	—	All 0	R	Reserved The write value should always be 0. Otherwise, operation cannot be guaranteed.
1	SPSLN1	0	R/W	Sequence Length Specification
0	SPSLN0	0	R/W	These bits specify a sequence length when this module in master mode performs sequential operations. This module in master mode changes command registers 0 to 3 (SPCMD0 to SPCMD3) to be referenced and the order in which they are referenced according to the sequence length that is set in the SPSLN1 and SPSLN0 bits. The relationship among the setting of bits SPSLN1 and SPSLN0, sequence length, and SPCMD0 to SPCMD3 referenced by this module is shown below. In slave mode, SPCMD0 is always referenced.

	Sequence Length	Referenced SPCMD #
00:	1	0 → 0 → ...
01:	2	0 → 1 → 0 → ...
10:	3	0 → 1 → 2 → 0 → ...
11:	4	0 → 1 → 2 → 3 → 0 → ...

24.3.7 Sequence Status Register (SPSSR)

SPSSR indicates the sequence control status when this module operates in master mode.

Bit	7	6	5	4	3	2	1	0
	—	—	—	—	—	—	SPCP1	SPCP0
Initial Value	0	0	0	0	0	0	0	0
R/W	R	R	R	R	R	R	R	R

Bit	Bit Name	Initial Value	R/W	Description
7 to 2	—	All 0	R	Reserved The write value should always be 0. Otherwise, operation cannot be guaranteed.
1	SPCP1	0	R	Command Pointer
0	SPCP0	0	R	During sequence control, these bits indicate one of the command registers 0 to 3 (SPCMD0 to SPCMD3) that is currently pointed to by the pointer. The relationship between the setting of SPCP1 and SPCP0 and SPCMD0 to SPCMD3 is shown below. For the sequence control, see Section 24.4.8(1)(c), Sequence Control . 00: SPCMD0 01: SPCMD1 10: SPCMD2 11: SPCMD3

24.3.8 Bit Rate Register (SPBR)

SPBR sets the bit rate in master mode. If the contents of SPBR are changed while the MSTR and SPE bits in the control register (SPCR) are 1 with the function of this module enabled in master mode, the subsequent operation cannot be guaranteed.

Bit	7	6	5	4	3	2	1	0
	SPR7	SPR6	SPR5	SPR4	SPR3	SPR2	SPR1	SPR0
Initial Value	1	1	1	1	1	1	1	1
	R/W	R/W	R/W	R/W	R/W	R/W	R/W	R/W

When this module is used in slave mode, the bit rate depends on the bit rate of the input clock regardless of the settings of SPBR and BRDV.

The bit rate is determined by combinations of SPBR settings and the bit settings in the BRDV1 and BRDV0 bits in the command registers (SPCMD0 to SPCMD3). The equation for calculating the bit rate is given below. In the equation, n denotes an SPBR setting (0, 1, 2, ..., 255), and N denotes a BRDV1 and BRDV0 bit setting (0, 1, 2, 3).

$$\text{Bit rate} = \frac{f(P0\phi)}{2 \times (n + 1) \times 2^N}$$

Table 24.3 shows examples of the relationship between the SPBR register and BRDV1 and BRDV0 bit settings.

Table 24.3 Relationship between SPBR and BRDV1 and BRDV0 Settings

SPBR (n)	BRDV[1:0] (N)	Division Ratio	Bit Rate*1
			P0φ = 100 MHz
0	0	2	Not Available
1	0	4	25.00 Mbps
2	0	6	16.67 Mbps
3	0	8	12.50 Mbps
4	0	10	10.00 Mbps
5	0	12	8.33 Mbps
5	1	24	4.17 Mbps
5	2	48	2.08 Mbps
5	3	96	1.04 Mbps
255	3	4096	24.41 Kbps

Note 1. Decide the bit rate to be actually used in the system considering timing specifications.

24.3.9 Data Control Register (SPDCR)

SPDCR selects the width to access SPDR from longword-, word-, and byte-width, and enables or disables dummy data transmission for the master mode operation.

If the contents of SPDCR are changed while bit TEND in the status register (SPSR) indicates that transmission is not completed, the subsequent operation cannot be guaranteed.

Bit	7	6	5	4	3	2	1	0
	TXDMY	SPLW1	SPLW0	—	—	—	—	—
Initial Value	0	0	1	0	0	0	0	0
R/W	R/W	R/W	R/W	R	R	R	R	R

Bit	Bit Name	Initial Value	R/W	Description
7	TXDMY	0	R/W	<p>Dummy Data Transmission Enable</p> <p>Enables or disables dummy data transmission.</p> <p>When communication is performed with this bit set to 1, dummy data is transmitted from the MOSI pin and a serial communication can be performed even if there is no transmit data in the transmit buffer.</p> <p>Specifically, if there is no transmit data in the transmit buffer and this bit is set to 1, dummy data is transferred to the shift register. Data previously transmitted from the pin is used as dummy data. If this bit is set to 1 after the initialization and a transfer is performed, the transmitted dummy data is undefined.</p> <p>0: Disables dummy data transmission. 1: Enables dummy data transmission.</p> <p><i>Note:</i> This bit is valid only in the master mode.</p>
6	SPLW1	0	R/W	Access Width Specification
5	SPLW0	1	R/W	<p>Specifies the width for accessing the data register (SPDR). If the length of data transferred to SPDR does not agree with these bit settings, operation is not guaranteed.*1</p> <p>00: Setting prohibited 01: SPDR is accessed in bytes (8 bits). 10: SPDR is accessed in words (16 bits). 11: SPDR is accessed in longwords (32 bits).</p>
4 to 0	—	All 0	R	<p>Reserved</p> <p>The write value should always be 0. Otherwise, operation cannot be guaranteed.</p>

Note 1. The data length is specified by the SPB3 to SPB0 bits in the command register (SPCMD).
See **Section 24.3.5, Data Register (SPDR)**.

24.3.10 Clock Delay Register (SPCKD)

SPCKD sets a period from the beginning of SSL signal assertion to RSPCK oscillation (RSPCK delay) when the SCKDEN bit in the command register (SPCMD) is 1. If the contents of SPCKD are changed while the MSTR and SPE bits in the control register (SPCR) are 1 with the function of this module enabled in master mode, the subsequent operation cannot be guaranteed.

When using this module in slave mode, set 000b to SCKDL2 to SCKDL0.

Bit	7	6	5	4	3	2	1	0
	—	—	—	—	—	SCKDL 2	SCKDL 1	SCKDL 0
Initial Value	0	0	0	0	0	0	0	0
R/W	R	R	R	R	R	R/W	R/W	R/W

Bit	Bit Name	Initial Value	R/W	Description
7 to 3	—	All 0	R	Reserved The write value should always be 0. Otherwise, operation cannot be guaranteed.
2	SCKDL2	0	R/W	RSPCK Delay Setting
1	SCKDL1	0	R/W	These bits set an RSPCK delay value when the SCKDEN bit in SPCMD is 1.
0	SCKDL0	0	R/W	The relationship between the setting of SCKDL2 to SCKDL0 and the RSPCK delay value is shown below. 000: 1 RSPCK 001: 2 RSPCK 010: 3 RSPCK 011: 4 RSPCK 100: 5 RSPCK 101: 6 RSPCK 110: 7 RSPCK 111: 8 RSPCK

24.3.11 Slave Select Negation Delay Register (SSLND)

SSLND sets a period (SSL negation delay) from the transmission of a final RSPCK edge to the negation of the SSL signal during a serial transfer by this module in master mode. If the contents of SSLND are changed while the MSTR and SPE bits in the control register (SPCR) are 1 with the function of this module enabled in master mode, the subsequent operation cannot be guaranteed.

When using this module in slave mode, set 000b to SLNDL2 to SLNDL0.

Bit	7	6	5	4	3	2	1	0
	—	—	—	—	—	SLNDL2	SLNDL1	SLNDL0
Initial Value	0	0	0	0	0	0	0	0
R/W	R	R	R	R	R	R/W	R/W	R/W

Bit	Bit Name	Initial Value	R/W	Description
7 to 3	—	All 0	R	Reserved The write value should always be 0. Otherwise, operation cannot be guaranteed.
2	SLNDL2	0	R/W	SSL Negation Delay Setting
1	SLNDL1	0	R/W	These bits set an SSL negation delay when the SLNDEN bit in SPCMD is 1.
0	SLNDL0	0	R/W	The relationship between the setting of SLNDL2 to SLNDL0 and the SSL negation delay value is shown below. 000: 1 RSPCK 001: 2 RSPCK 010: 3 RSPCK 011: 4 RSPCK 100: 5 RSPCK 101: 6 RSPCK 110: 7 RSPCK 111: 8 RSPCK

24.3.12 Next-Access Delay Register (SPND)

SPND sets a non-active period (next-access delay) after termination of a serial transfer when the SPNDEN bit in the command register (SPCMD) is 1. If the contents of SPND are changed while the MSTR and SPE bits in the control register (SPCR) are 1 with the function of this module enabled in master mode, the subsequent operation cannot be guaranteed.

When using this module in slave mode, set 000b to SPNDL2 to SPNDL0.

Bit	7	6	5	4	3	2	1	0
	—	—	—	—	—	SPNDL 2	SPNDL 1	SPNDL 0
Initial Value	0	0	0	0	0	0	0	0
R/W	R	R	R	R	R	R/W	R/W	R/W

Bit	Bit Name	Initial Value	R/W	Description
7 to 3	—	All 0	R	Reserved The write value should always be 0. Otherwise, operation cannot be guaranteed.
2	SPNDL2	0	R/W	Next-Access Delay Setting
1	SPNDL1	0	R/W	These bits set a next-access delay when the SPNDEN bit in SPCMD is 1.
0	SPNDL0	0	R/W	The relationship between the setting of SPNDL2 to SPNDL0 and the next-access delay value is shown below. 000: 1 RSPCK + 2 P0φ 001: 2 RSPCK + 2 P0φ 010: 3 RSPCK + 2 P0φ 011: 4 RSPCK + 2 P0φ 100: 5 RSPCK + 2 P0φ 101: 6 RSPCK + 2 P0φ 110: 7 RSPCK + 2 P0φ 111: 8 RSPCK + 2 P0φ

24.3.13 Command Register (SPCMD)

Each channel has four command registers (SPCMD0 to SPCMD3). SPCMD0 to SPCMD3 are used to set a transfer format for master mode operation. Some of the bits in SPCMD0 are used to set a transfer mode for slave mode operation. In master mode, this module sequentially references SPCMD0 to SPCMD3 according to the settings in bits SPSTN1 and SPSTN0 in the sequence control register (SPSCR), and executes the serial transfer that is set in the referenced SPCMD. While bit TEND in the status register (SPSR) indicates that transmission is not completed, correct operation of this module cannot be guaranteed if SPCMD is changed that is referred by this module. SPCMD referenced by this module in master mode can be checked by means of bits SPCP1 and SPCP0 in the sequence status register (SPSSR). When the function of this module in slave mode is enabled, operation cannot be guaranteed if the value set in SPCMD0 is changed.

Bit	15	14	13	12	11	10	9	8	7	6	5	4	3	2	1	0
	SCKDEN	SLNDEN	SPNDEN	LSBF	SPB3	SPB2	SPB1	SPB0	SSLKP	—	—	—	BRDV1	BRDV0	CPOL	CPHA
Initial Value	0	0	0	0	0	1	1	1	0	0	0	0	1	1	0	1
R/W	R/W	R/W	R/W	R/W	R/W	R/W	R/W	R/W	R/W	R	R	R	R/W	R/W	R/W	R/W

Bit	Bit Name	Initial Value	R/W	Description
15	SCKDEN	0	R/W	<p>RSPCK Delay Setting Enable</p> <p>Sets the period from the point this module in master mode activates the SSL signal until the RSPCK starts oscillation (RSPCK delay). If the SCKDEN bit is 0, this module sets the RSPCK delay to 1 RSPCK. If the SCKDEN bit is 1, this module starts the oscillation of RSPCK at an RSPCK delay in compliance with the clock delay register (SPCKD) settings.</p> <p>To use this module in slave mode, the SCKDEN bit should be set to 0.</p> <p>0: An RSPCK delay of 1 RSPCK 1: An RSPCK delay equal to SPCKD settings.</p>
14	SLNDEN	0	R/W	<p>SSL Negation Delay Setting Enable</p> <p>Sets the period from the point this module in master mode stops RSPCK oscillation until this module sets the SSL signal inactive (SSL negation delay). If the SLNDEN bit is 0, this module sets the SSL negation delay to 1 RSPCK. If the SLNDEN bit is 1, this module negates the SSL signal at an SSL negation delay in compliance with the slave select negation delay register (SSLND) settings.</p> <p>To use this module in slave mode, the SLNDEN bit should be set to 0.</p> <p>0: An SSL negation delay of 1 RSPCK 1: An SSL negation delay equal to SSLND settings.</p>
13	SPNDEN	0	R/W	<p>Next-Access Delay Enable</p> <p>Sets the period from the point this module in master mode terminates a serial transfer and sets the SSL signal inactive until this module enables the SSL signal assertion for the next access (next-access delay). If the SPNDEN bit is 0, this module sets the next-access delay to 1 RSPCK + 2P0φ. If the SPNDEN bit is 1, this module inserts a next-access delay in compliance with the next-access delay register (SPND) settings.</p> <p>To use this module in slave mode, the SPNDEN bit should be set to 0.</p> <p>0: A next-access delay of 1 RSPCK + 2 P0φ 1: A next-access delay equal to SPND settings.</p>
12	LSBF	0	R/W	<p>LSB First</p> <p>Sets the data format in master mode or slave mode to MSB first or LSB first.</p> <p>0: MSB first 1: LSB first</p>

Bit	Bit Name	Initial Value	R/W	Description
11	SPB3	0	R/W	Data Length Setting
10	SPB2	1	R/W	These bits set a transfer data length in master mode or slave mode. 0100 to 0111: 8 bits 1111: 16 bits 0010, 0011: 32 bits Others: Setting prohibited
9	SPB1	1	R/W	
8	SPB0	1	R/W	
7	SSLKP	0	R/W	<p>SSL Signal Level Keeping</p> <p>When this module in master mode performs a serial transfer, this bit specifies whether the SSL signal level for the current command is to be kept or negated between the SSL negation timing associated with the current command and the SSL assertion timing associated with the next command.</p> <p>To use this module in slave mode, the SSLKP bit should be set to 0.</p> <p>0: Negates the SSL signal upon completion of transfer. 1: Keeps the SSL signal level from the end of the transfer until the beginning of the next access.</p>
6 to 4	—	All 0	R	<p>Reserved</p> <p>The write value should always be 0. Otherwise, operation cannot be guaranteed.</p>
3	BRDV1	1	R/W	<p>Bit Rate Division Setting</p> <p>These bits are used to determine the bit rate. A bit rate is determined by combinations of bits BRDV1 and BRDV0 and the settings in the bit rate register (SPBR) (see Section 24.3.8, Bit Rate Register (SPBR)). The settings in SPBR determine the base bit rate. The settings in bits BRDV1 and BRDV0 are used to select a bit rate which is obtained by dividing the base bit rate by 1, 2, 4, or 8. In the bits SPCMD0 to SPCMD3, different BRDV1 and BRDV0 settings can be specified. This permits the execution of serial transfers at a different bit rate for each command.</p> <p>00: Select the base bit rate. 01: Select the base bit rate divided by 2. 10: Select the base bit rate divided by 4. 11: Select the base bit rate divided by 8.</p>
2	BRDV0	1	R/W	
1	CPOL	0	R/W	<p>RSPCK Polarity Setting</p> <p>Sets an RSPCK polarity in master or slave mode. When data communication is performed between the Renesas serial peripheral interface module and the other modules, the same RSPCK polarity should be set for both modules.</p> <p>0: RSPCK = 0 when idle 1: RSPCK = 1 when idle</p>
0	CPHA	1	R/W	<p>RSPCK Phase Setting</p> <p>Sets an RSPCK phase in master or slave mode. When data communication is performed between the Renesas serial peripheral interface module and the other modules, the same RSPCK phase should be set for both modules.</p> <p>0: Data sampling on odd edge, data variation on even edge 1: Data variation on odd edge, data sampling on even edge</p>

24.3.14 Buffer Control Register (SPBFCR)

SPBFCR resets the number of data units in the transmit buffer (SPTX) or receive buffer (SPRX) and sets the number of triggering data units.

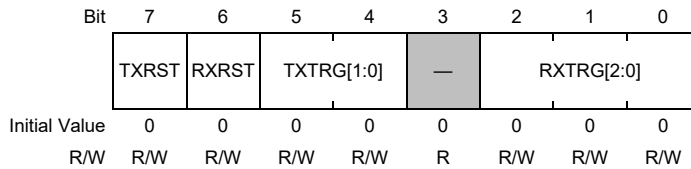

Bit	Bit Name	Initial Value	R/W	Description
7	TXRST	0	R/W	<p>Transmit Buffer Data Reset</p> <p>Resets the transmit buffer to an empty state. Transmit data in the transmit buffer becomes invalid when this bit is set to 1.</p> <p>0: Disables the reset operation.*1 1: Enables the reset operation</p> <p><i>Note 1.</i> The reset operation is performed after a power-on reset.</p>
6	RXRST	0	R/W	<p>Receive Buffer Data Reset</p> <p>Resets the receive buffer to an empty state. Receive data in the receive buffer becomes invalid when this bit is set to 1.</p> <p>0: Disables the reset operation.*1 1: Enables the reset operation</p> <p><i>Note 1.</i> The reset operation is performed after a power-on reset.</p>
5, 4	TXTRG[1:0]	00	R/W	<p>Transmit Buffer Data Triggering Number*2</p> <p>Specifies the timing at which the transmit buffer empty state is determined, that is when the SPTEF flag in the status register is set. When the number of bytes of data in the transmit buffer (SPTX) is equal to or less than the specified triggering number, the SPTEF flag is set to 1.</p> <p>00: 7 bytes (1)*1 01: 6 bytes (2)*1 10: 4 bytes (4)*1 11: 0 bytes (8)*1</p> <p><i>Note 1.</i> The value in the parenthesis shows the number of available bytes in the transmit buffer (SPTX).</p> <p><i>Note 2.</i> When transferring the data by using DMA, set the following values according to the data transfer length. (The data transfer length is set in SPBn (n = 0-3) of the command register (SPCMD)).</p> <p>1) Data transfer length is 1 byte SPBFCR (TXTRG): 01 (6 bytes) or 10 (4 byte) or 11 (0 byte)</p> <p>2) Data transfer length is 2 bytes SPBFCR (TXTRG): 10 (4 bytes) or 11 (0 byte)</p> <p>3) Data transfer length is 4bytes SPBFCR (TXTRG): 11 (0 byte)</p>
3	—	0	R	<p>Reserved</p> <p>The write value should always be 0. Otherwise, operation cannot be guaranteed.</p>

Bit	Bit Name	Initial Value	R/W	Description
2 to 0	RXTRG[2:0]	000	R/W	<p>Receive Buffer Data Triggering Number</p> <p>Specifies the timing at which the receive buffer full state is determined, that is when the SPRF flag in the status register is set. When the number of bytes of data in the receive buffer (SPRX) is equal to or greater than the specified triggering number, the SPRF flag is set to 1.</p> <p>000: 1 byte (31)*¹ 001: 2 bytes (30)*¹ 010: 4 bytes (28)*¹ 011: 8 bytes (24)*¹ 100: 16 bytes (16)*¹ 101: 24 bytes (8)*¹ 110: 32 bytes (0)*¹ 111: 5 bytes (27)*¹</p> <p><i>Note 1.</i> The value in the parenthesis shows the number of available bytes in the receive buffer (SPRX).</p>

24.3.15 Buffer Data Count Setting Register (SPBFDR)

SPBFDR indicates the number of data units stored in the transmit buffer (SPTX) and receive buffer (SPRX). The upper eight bits indicate the number of transmit data units in SPTX and the lower eight bits indicate the number of receive data units in SPRX.

Bit	15	14	13	12	11	10	9	8	7	6	5	4	3	2	1	0
	—	—	—	—	T[3:0]				—	—	R[5:0]					
Initial Value	0	0	0	0	0	0	0	0	0	0	0	0	0	0	0	0
R/W	R	R	R	R	R	R	R	R	R	R	R	R	R	R	R	R

Bit	Bit Name	Initial Value	R/W	Description
15 to 12	—	All 0	R	Reserved The write value should always be 0. Otherwise, operation cannot be guaranteed.
11 to 8	T[3:0]	0000	R	Indicates the number of bytes of data to be transmitted in SPTX. 0000b indicates that SPTX is empty. 1000b indicates that SPTX is full.
7, 6	—	All 0	R	Reserved The write value should always be 0. Otherwise, operation cannot be guaranteed.
5 to 0	R[5:0]	000000	R	Shows the number of bytes of received data in SPRX. 000000b indicates that SPRX is empty. 100000b indicates that SPRX is full.

24.4 Operation

In this section, the serial transfer period means a period from the beginning of driving valid data to the fetching of the final valid data.

24.4.1 Overview of Operations

This module is capable of serial transfers in slave mode and master mode. A particular mode of this module can be selected by using the MSTR bit in the control register (SPCR). **Table 24.4** gives the relationship between the modes and SPCR settings, and a description of each mode.

Table 24.4 Relationship between Modes and SPCR and Description of Each Mode

Mode	Slave (SPI Operation)	Master (SPI Operation)
MSTR bit setting	0	1
MODFEN bit setting	0 or 1	0
RSPCK signal	Input	Output
MOSI signal	Input	Output
MISO signal	Output/Hi-Z	Input
SSL signal	Input	Output
SSL polarity modification function	Supported	Supported
Transfer rate	Up to $P0\phi/8$	Up to $P0\phi/2$ (Up to $P0\phi/4$ when $P0\phi$ is 100 MHz)
Clock source	RSPCK input	On-chip baud rate generator
Clock polarity	Two	Two
Clock phase	Two	Two
First transfer bit	MSB/LSB	MSB/LSB
Transfer data length	8, 16, or 32 bits	8, 16, or 32 bits
Burst transfer	Possible (CPHA = 1)	Possible (CPHA = 0, 1)
RSPCK delay control	Not supported	Supported
SSL negation delay control	Not supported	Supported
Next-access delay control	Not supported	Supported
Transfer activation method	SSL input active or RSPCK oscillation	Transmit buffer is written when SPE = 1
Sequence control	Not supported	Supported
Transmit buffer empty detection	Supported	Supported
Receive buffer full detection	Supported	Supported
Overrun error detection	Supported	Not Supported
Mode fault error detection	Supported (MODFEN = 1)	Not supported

24.4.2 Pin Control

According to the MSTR bit in the control register (SPCR), this module can automatically switch pin directions and output modes. **Table 24.5** shows the relationship between pin states and bit settings.

Table 24.5 Relationship between Pin States and Bit Settings

Mode	Pin	Pin State*1
Master mode (SPI operation) (MSTR = 1)	RSPCK	CMOS output
	SSL	CMOS output
	MOSI	CMOS output
	MISO	Input
Slave mode (SPI operation) (MSTR = 0)	RSPCK	Input
	SSL	Input
	MOSI	Input
	MISO*1	CMOS output/Hi-Z

Note 1. When SSL is at the non-active level or the SPE bit in SPCR is cleared to 0, the pin state is Hi-Z.

This module in master mode (SPI operation) determines MOSI signal values during the SSL negation period (including the SSL retention period during a burst transfer) according to MOIFE and MOIFV bit settings in SPPCR, as shown in **Table 24.6**.

Table 24.6 MOSI Signal Value Determination during SSL Negation Period

MOIFE	MOIFV	MOSI Signal Value during SSL Negation Period
0	0, 1	Last output value from previous transfer (The value is undefined when CPHA is 0)
1	0	Always 0
1	1	Always 1

24.4.3 System Configuration Example

(1) Master/Slave (with This LSI Acting as Master)

Figure 24.2 shows a master/slave system configuration example when this LSI is used as a master. In master/slave configuration, the SSL output of this LSI (master) is not used. The SSL input of the slave is fixed to the low level, and the slave is always maintained in a selected state. In the transfer format corresponding to the case where the CPHA bit in the control register (SPCR) is 0, there are slave devices for which the SSL signal cannot be fixed to the active level. In situations where the SSL signal cannot be fixed, the SSL output of this LSI should be connected to the SSL input of the slave device.

This LSI (master) always drives the RSPCK and MOSI. The slave always drives the MISO.

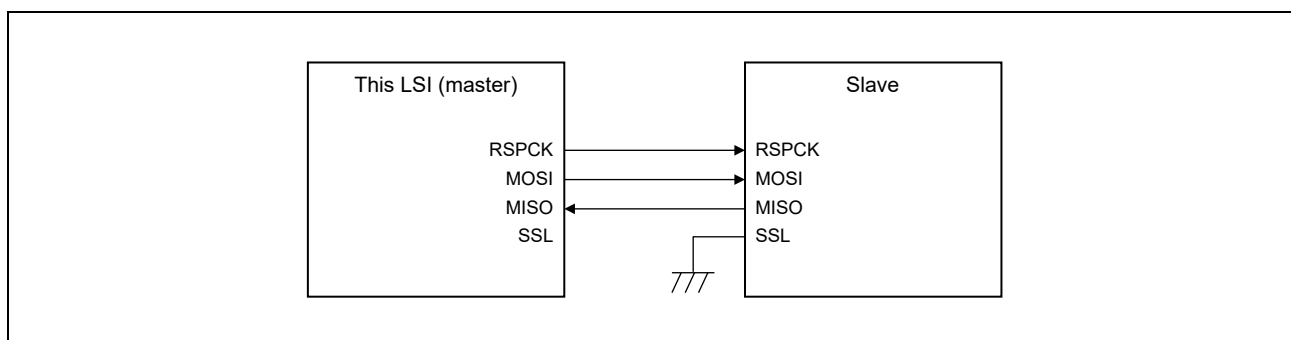

Figure 24.2 Master/Slave Configuration Example (This LSI = Master)

(2) Master/Slave (with This LSI Acting as Slave)

Figure 24.3 shows a master/slave system configuration example when this LSI is used as a slave. When this LSI is to operate as a slave, the SSL pin is used as SSL input. The master always drives the RSPCK and MOSI. This LSI (slave) always drives the MISO. When SSL is at the non-active level, the pin state is Hi-Z.

In the slave configuration in which the CPHA bit in the command register (SPCMD) is set to 1, the SSL input of this LSI (slave) is fixed to the 0 level, this LSI (slave) is always maintained in a selected state, and in this manner it is possible to execute serial transfer (**Figure 24.4**).

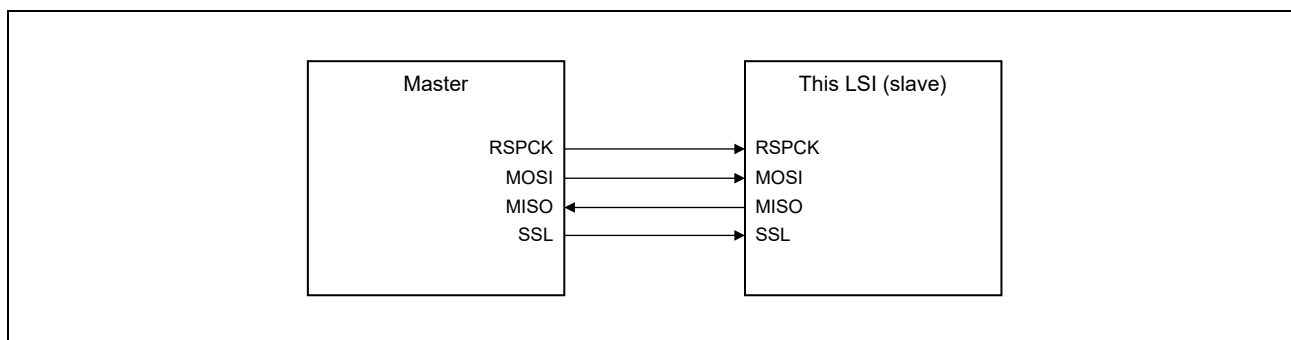

Figure 24.3 Master/Slave Configuration Example (This LSI = Slave)

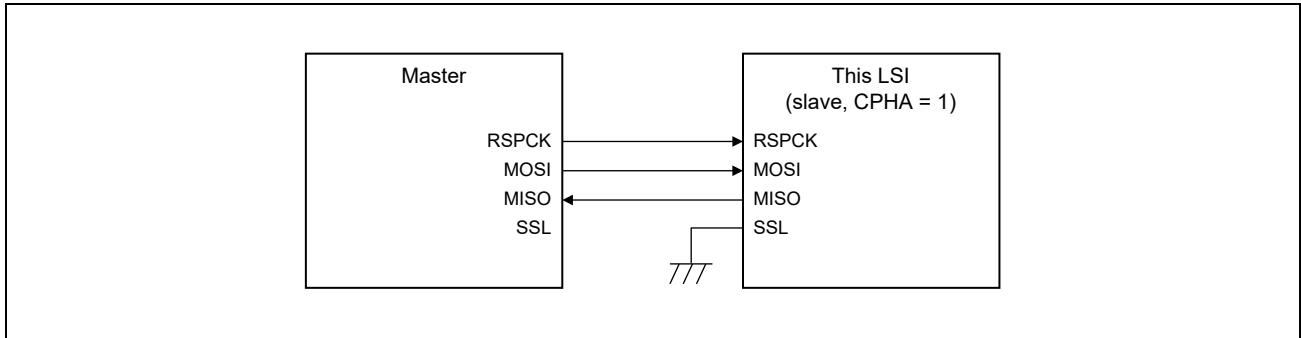

Figure 24.4 Master/Slave Configuration Example (This LSI = Slave, CPHA = 1)

(3) Master/Multi-Slave (with This LSI Acting as Slave)

Figure 24.5 shows a master/multi-slave system configuration example when this LSI is used as a slave. In the example of **Figure 24.5**, the system is comprised of a master and two LSIs (slave X and slave Y).

The RSPCK and MOSI outputs of the master are connected to the RSPCK and MOSI inputs of the LSIs (slave X and slave Y). The MISO outputs of the LSIs (slave X and slave Y) are all connected to the MISO input of the master. SSLX and SSLY outputs of the master are connected to the SSL inputs of the LSIs (slave X and slave Y), respectively.

The master always drives RSPCK, MOSI, SSLX, and SSLY. Of the LSIs (slave X and slave Y), the slave that receives low level input into the SSL0 input drives MISO.

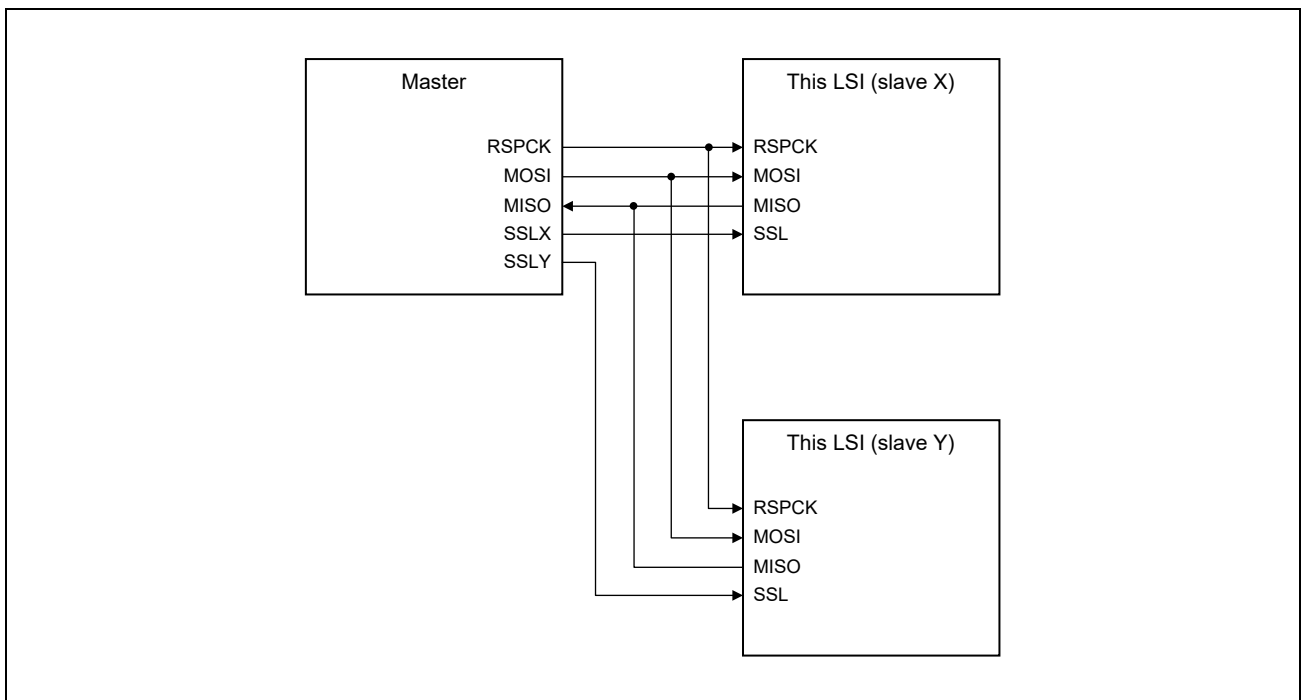

Figure 24.5 Master/Multi-Slave Configuration Example (This LSI = Slave)

24.4.4 Transfer Format

(1) CPHA = 0

Figure 24.6 shows a sample transfer format for the serial transfer of 8-bit data when the CPHA bit in the command register (SPCMD) is 0. In **Figure 24.6**, RSPCK (CPOL = 0) indicates the RSPCK signal waveform when the CPOL bit in SPCMD is 0; RSPCK (CPOL = 1) indicates the RSPCK signal waveform when the CPOL bit is 1. The sampling timing represents the timing at which this module fetches serial transfer data into the shift register. The input/output directions of the signals depend on the settings of this module. For details, see **Section 24.4.2, Pin Control**.

When the CPHA bit is 0, the driving of valid data to the MOSI and MISO signals commences at an SSL signal assertion timing. The first RSPCK signal change timing that occurs after the SSL signal assertion becomes the first transfer data fetching timing. After this timing, data is sampled at every 1 RSPCK cycle. The change timing for MOSI and MISO signals is always 1/2 RSPCK cycle after the transfer data fetch timing. The settings in the CPOL bit do not affect the RSPCK signal operation timing; they only affect the signal polarity.

t1 denotes a period from an SSL signal assertion to RSPCK oscillation (RSPCK delay). t2 denotes a period from the cessation of RSPCK oscillation to an SSL signal negation (SSL negation delay). t3 denotes a period in which SSL signal assertion is suppressed for the next transfer after the end of serial transfer (next-access delay). t1, t2, and t3 are controlled by a master device running on the system. For a description of t1, t2, and t3 when this module is in master mode, see **Section 24.4.3(1), Master/Slave (with This LSI Acting as Master)**.

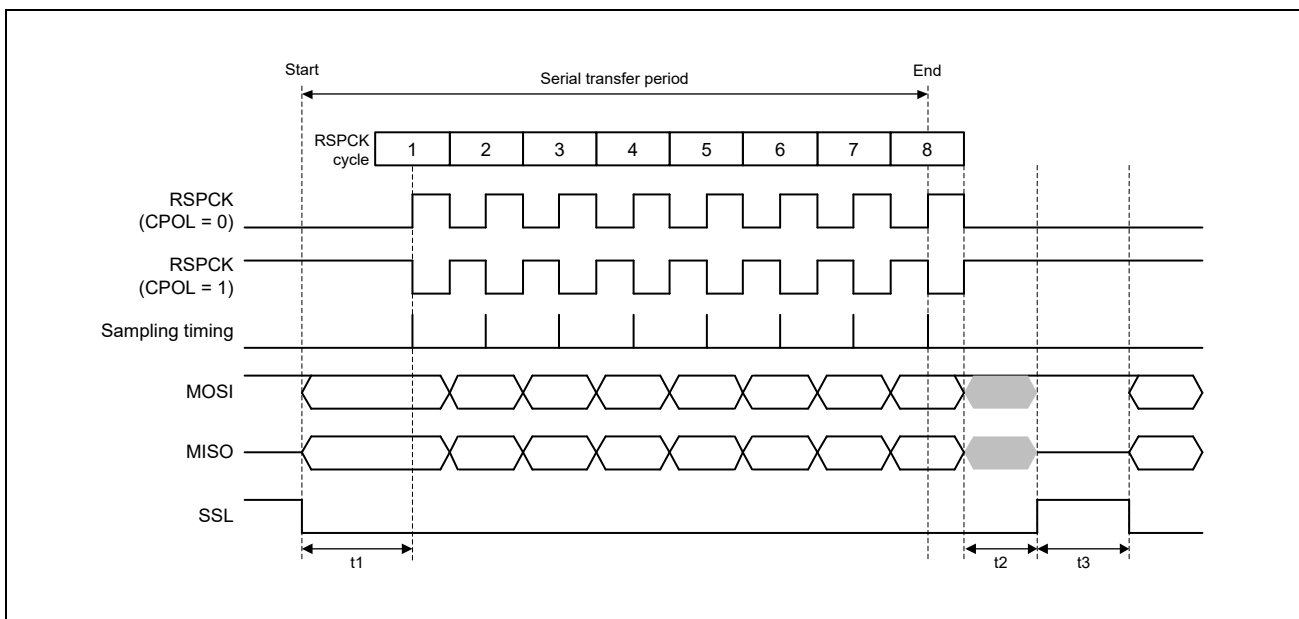

Figure 24.6 Transfer Format (CPHA = 0)

(2) CPHA = 1

Figure 24.7 shows a sample transfer format for the serial transfer of 8-bit data when the CPHA bit in the command register (SPCMD) is 1. In **Figure 24.7**, RSPCK (CPOL = 0) indicates the RSPCK signal waveform when the CPOL bit in SPCMD is 0; RSPCK (CPOL = 1) indicates the RSPCK signal waveform when the CPOL bit is 1. The sampling timing represents the timing at which this module fetches serial transfer data into the shift register. The input/output directions of the signals depend on the modes (master or slave). For details, see **Section 24.4.2, Pin Control**.

When the CPHA bit is 1, the driving of invalid data to the MOSI and MISO signals commences at an SSL signal assertion timing. The driving of valid data to the MOSI and MISO signals commences at the first RSPCK signal change timing that occurs after the SSL signal assertion. After this timing, data is updated at every 1 RSPCK cycle. The transfer data fetch timing is always 1/2 RSPCK cycle after the data update timing. The settings in the CPOL bit do not affect the RSPCK signal operation timing; they only affect the signal polarity.

t_1 , t_2 , and t_3 are the same as those in the case of CPHA = 0. For a description of t_1 , t_2 , and t_3 when this module is in master mode, see **Section 24.4.3(1), Master/Slave (with This LSI Acting as Master)**.

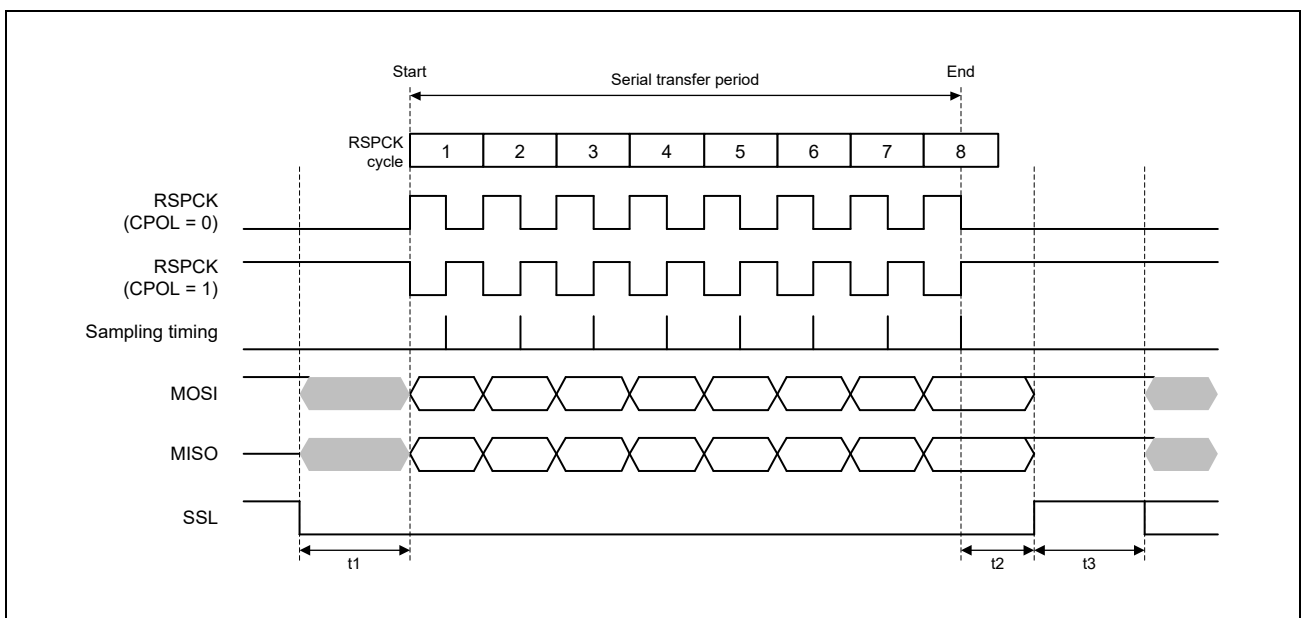

Figure 24.7 Transfer Format (CPHA = 1)

24.4.5 Data Format

The data format depends on the settings in the command register (SPCMD). Irrespective of MSB/LSB first, this module treats the range from the LSB of the data register (SPDR) to the assigned data length as transfer data.

(1) MSB First Transfer (32-Bit Data)

Figure 24.8 shows the operation of the transmit buffer (SPTX) and the shift register when this module performs a 32-bit data length MSB-first data transfer.

The CPU or direct memory access controller writes T31 to T00 to the transmit buffer of SPDR. If the shift register is empty, this module copies the data in the transmit buffer to the shift register, and fully populates the shift register. When serial transfer starts, this module outputs data from the MSB (bit 31) in the shift register, and shifts in the data from the LSB (bit 0) in the shift register. When the RSPCK cycle required for the serial transfer of 32 bits has passed, data R31 to R00 is stored in the shift register. In this state, this module copies the data from the shift register to the receive buffer, and empties the shift register. If the receive buffer does not have a space for the receive data length after the receive data has been copied from the shift register to the receive buffer, another serial transfer will not be started. In order to start another serial transfer, data for the receive data length should be read from the receive buffer to secure the necessary space in the receive buffer.

If another serial transfer is started before the CPU or direct memory access controller writes to the transmit buffer, received data R31 to R00 is shifted out from the shift register.

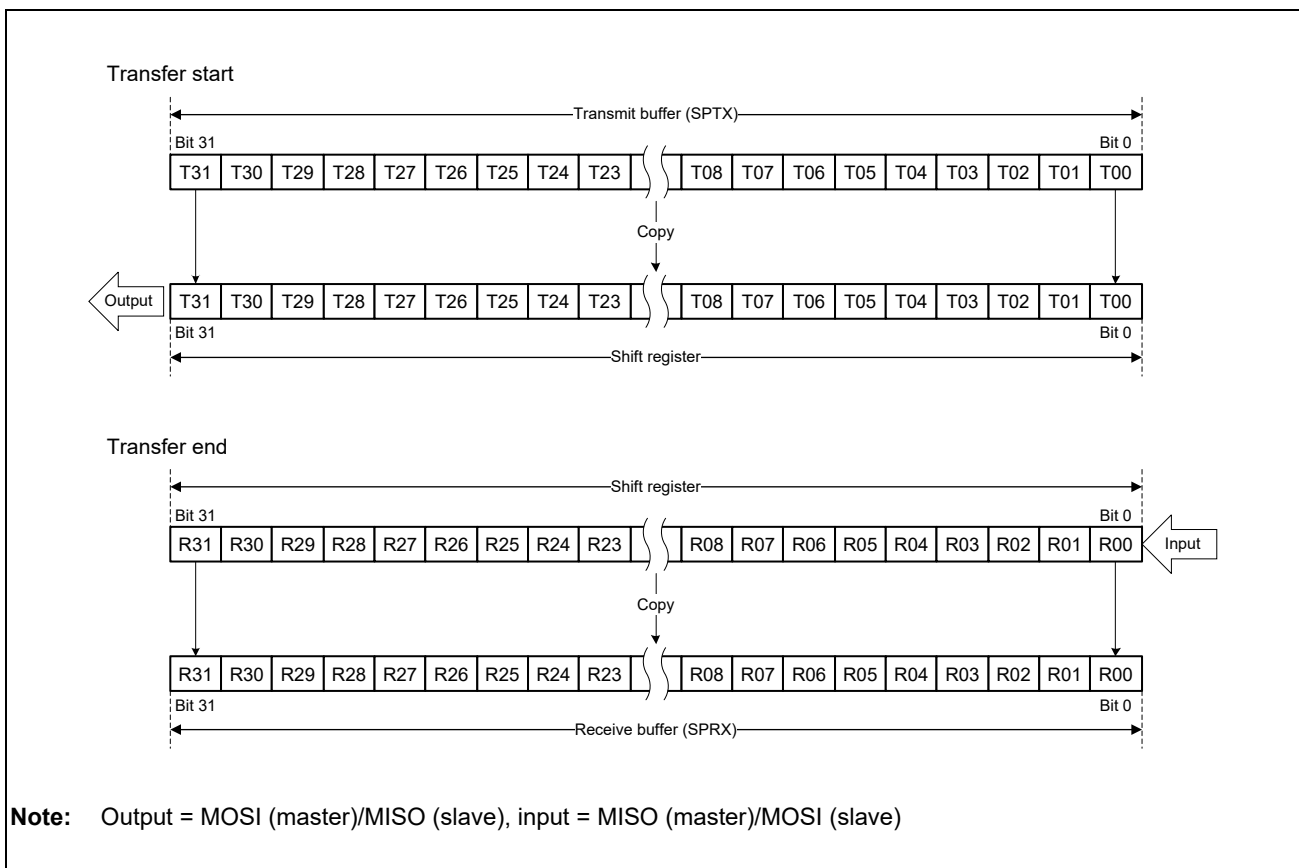

Figure 24.8 MSB First Transfer (32-Bit Data)

(2) MSB First Transfer (16-Bit Data)

Figure 24.9 shows the operation of the transmit buffer (SPTX) and the shift register when this module performs a 16-bit data length MSB-first data transfer.

The CPU or direct memory access controller writes T15 to T00 to the transmit buffer. If the shift register is empty, this module copies the data in the transmit buffer to the shift register, and fully populates the shift register. When serial transfer starts, this module outputs data from bit 15 in the shift register, and shifts in the data from the LSB (bit 0) in the shift register. When the RSPCK cycle required for the serial transfer of 16 bits has passed, received data R15 to R00 is stored in bits 15 to 0 in the shift register. After completion of the serial transfer, data that existed before the transfer is retained in bits 31 to 16 in the shift register. In this state, this module copies the data from the shift register to the receive buffer, and empties the shift register. If the receive buffer does not have a space for the receive data length after receive data has been copied from the shift register to the receive buffer, another serial transfer will not be started. In order to start another serial transfer, data for the receive data length should be read from the receive buffer to secure the necessary space in the receive buffer.

If another serial transfer is started before the CPU or direct memory access controller writes to the transmit buffer, received data R15 to R00 is shifted out from the shift register.

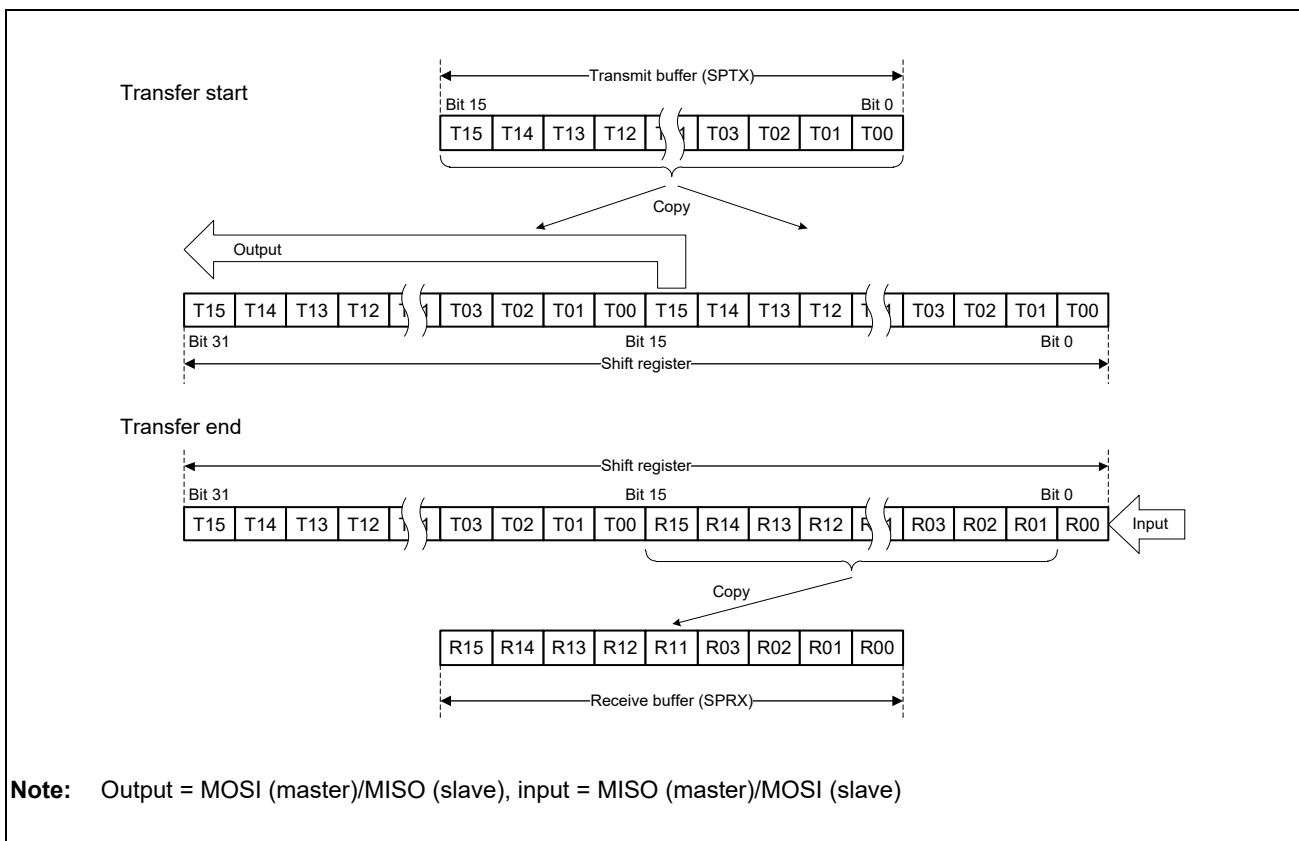

Figure 24.9 MSB First Transfer (16-Bit Data)

(3) MSB First Transfer (8-Bit Data)

Figure 24.10 shows the operation of the transmit buffer (SPTX) and the shift register when this module performs an 8-bit data length MSB-first data transfer.

The CPU or direct memory access controller writes T07 to T00 to the transmit buffer. If the shift register is empty, this module copies the data in the transmit buffer to the shift register, and fully populates the shift register. When serial transfer starts, this module outputs data from bit 7 in the shift register, and shifts in the data from the LSB (bit 0) in the shift register. When the RSPCK cycle required for the serial transfer of 8 bits has passed, received data R07 to R00 is stored in bits 7 to 0 in the shift register. After completion of the serial transfer, data that existed before the transfer is retained in bits 31 to 8 in the shift register. In this state, this module copies the data from the shift register to the receive buffer, and empties the shift register. If the receive buffer does not have a space for the receive data length after receive data has been copied from the shift register to the receive buffer, another serial transfer will not be started. In order to start another serial transfer, data for the receive data length should be read from the receive buffer to secure the necessary area in the receive buffer.

If another serial transfer is started before the CPU or direct memory access controller writes to the transmit buffer, received data R07 to R00 is shifted out from the shift register.

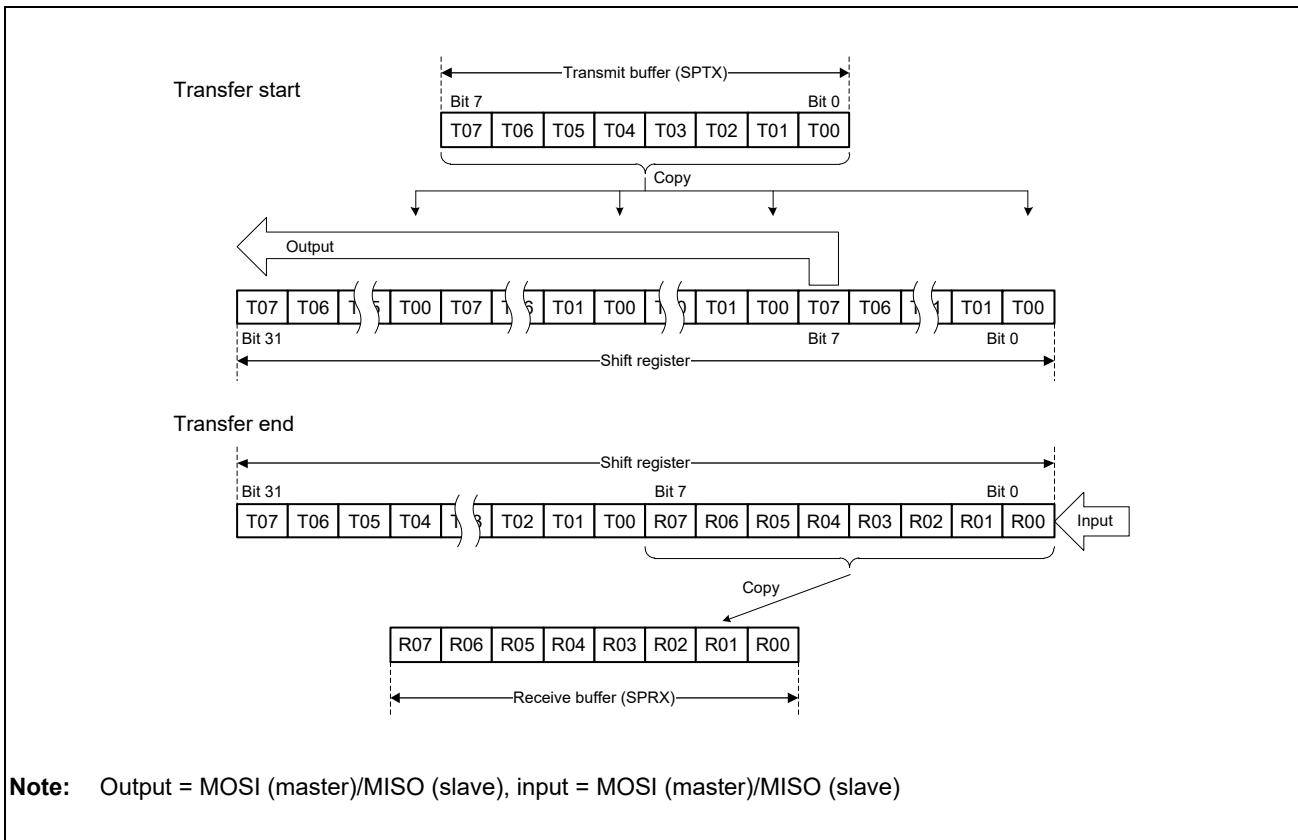

Figure 24.10 MSB First Transfer (8-Bit Data)

(4) LSB First Transfer (32-Bit Data)

Figure 24.11 shows the operation of the transmit buffer (SPTX) and the shift register when this module performs a 32-bit data length LSB-first data transfer.

The CPU or direct memory access controller writes T31 to T00 to the transmit buffer. If the shift register is empty, this module reverses the order of the bits of the data in the transmit buffer, copies it to the shift register, and fully populates the shift register. When serial transfer starts, this module outputs data from the MSB (bit 31) in the shift register, and shifts in the data from the LSB (bit 0) in the shift register. When the RSPCK cycle required for the serial transfer of 32 bits has passed, data R00 to R31 is stored in the shift register. In this state, this module copies the data, in which the order of the bits is reversed, from the shift register to the receive buffer, and empties the shift register. If the receive buffer does not have a space for the receive data length after receive data has been copied from the shift register to the receive buffer, another serial transfer will not be started. In order to start another serial transfer, data for the receive data length should be read from the receive buffer to secure the necessary space in the receive buffer.

If another serial transfer is started before the CPU or direct memory access controller writes to the transmit buffer of the SPDR, received data R00 to R31 is shifted out from the shift register.

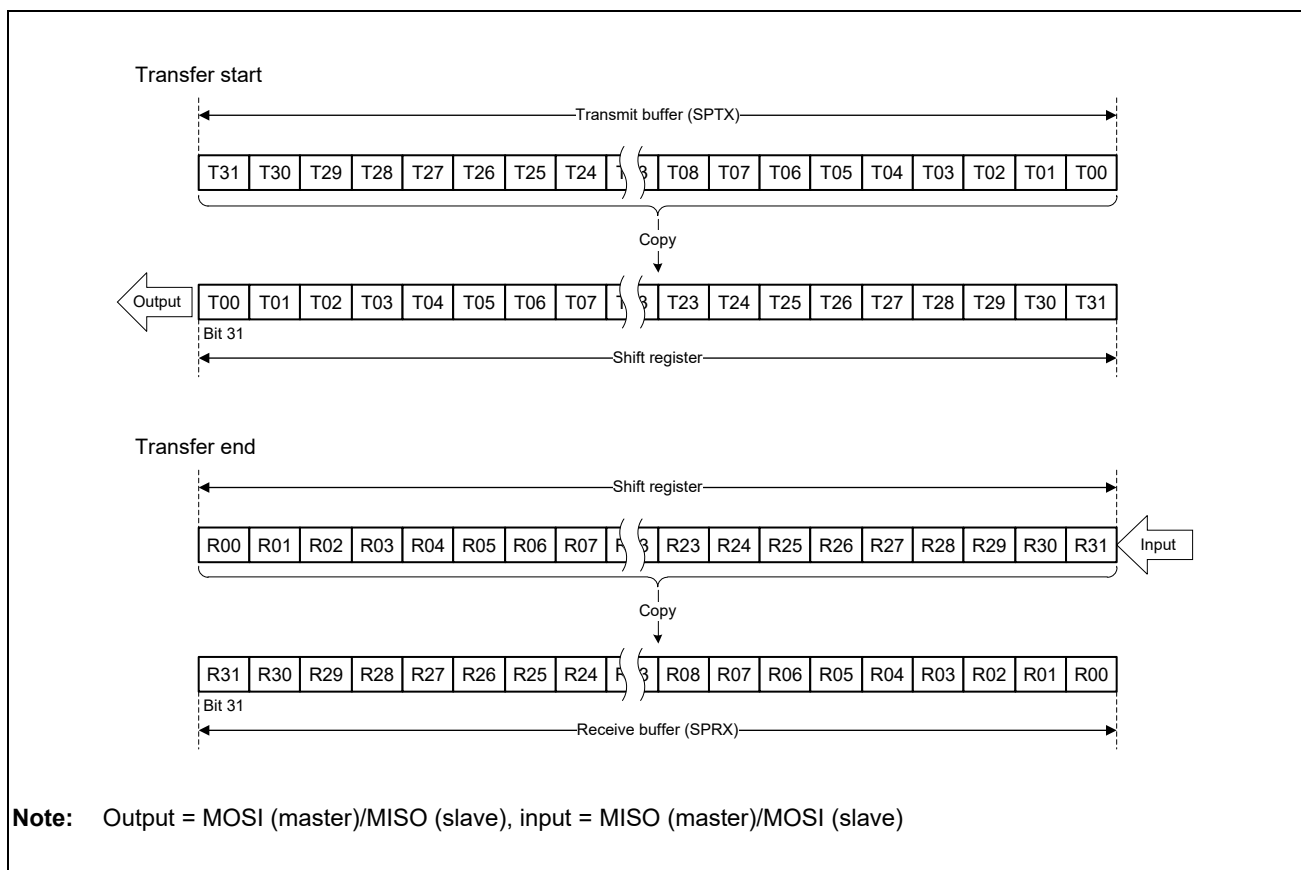

Figure 24.11 LSB First Transfer (32-Bit Data)

(5) LSB First Transfer (16-Bit Data)

Figure 24.12 shows the operation of the transmit buffer (SPTX) and the shift register when this module performs a 16-bit data length LSB-first data transfer.

The CPU or direct memory access controller writes T15 to T00 to the transmit buffer. If the shift register is empty, this module reverses the order of the bits of the data in the transmit buffer, copies it to the shift register, and fully populates the shift register. When serial transfer starts, this module outputs data from the MSB (bit 31) in the shift register, and shifts in the data from bit 16 in the shift register. When the RSPCK cycle required for the serial transfer of 16 bits has passed, received data R00 to R15 is stored in bits 31 to 16 in the shift register. After completion of the serial transfer, data that existed before the transfer is retained in bits 15 to 0 in the shift register. In this state, this module copies the data, in which the order of the bits is reversed, from the shift register to the receive buffer of SPDR, and empties the shift register. If the receive buffer does not have a space for the receive data length after receive data has been copied from the shift register to the receive buffer, another serial transfer will not be started. In order to start another serial transfer, data for the receive data length should be read from the receive buffer to secure the necessary space in the receive buffer.

If another serial transfer is started before the CPU or direct memory access controller writes to the transmit buffer of SPDR, received data R00 to R15 is shifted out from the shift register.

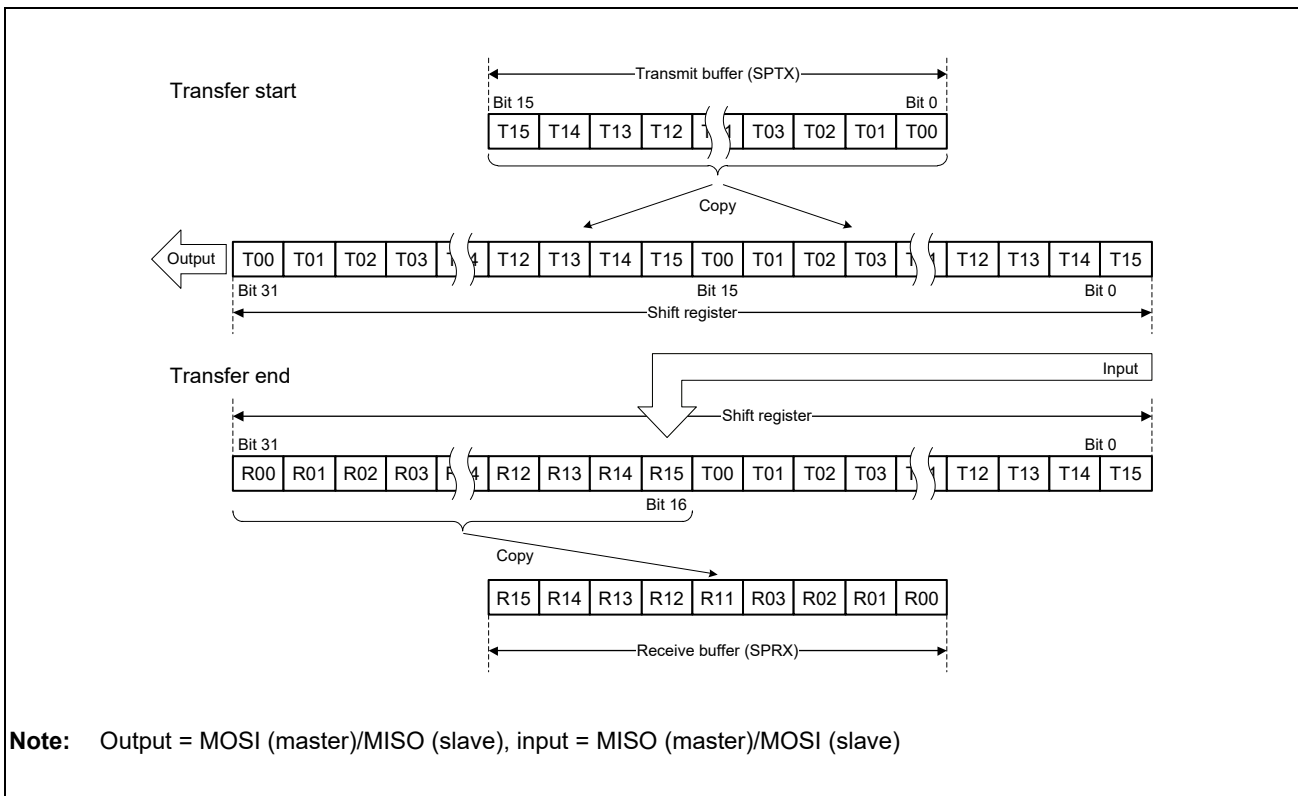

Figure 24.12 LSB First Transfer (16-Bit Data)

(6) LSB First Transfer (8-Bit Data)

Figure 24.13 shows the operation of the transmit buffer (SPTX) and the shift register when this module performs an 8-bit data length LSB-first data transfer.

The CPU or direct memory access controller writes T07 to T00 to the transmit buffer. If the shift register is empty, this module reverses the order of the bits of the data in the transmit buffer, copies it to the shift register, and fully populates the shift register. When serial transfer starts, this module outputs data from the MSB (bit 31) in the shift register, and shifts in the data from bit 24 in the shift register. When the RSPCK cycle required for the serial transfer of 8 bits has passed, received data R00 to R07 is stored in bits 31 to 24 of the shift register. After completion of the serial transfer, data that existed before the transfer is retained in bits 23 to 0 in the shift register. In this state, this module copies the data, in which the order of the bits is reversed, from the shift register to the receive buffer of SPDR, and empties the shift register. If the receive buffer does not have a space for the receive data length after the receive data has been copied from the shift register to the receive buffer, another serial transfer will not be started. In order to start another serial transfer, data for the receive data length should be read from the receive buffer to secure the necessary space in the receive buffer.

If another serial transfer is started before the CPU or direct memory access controller writes to the transmit buffer of SPDR, received data R00 to R07 is shifted out from the shift register.

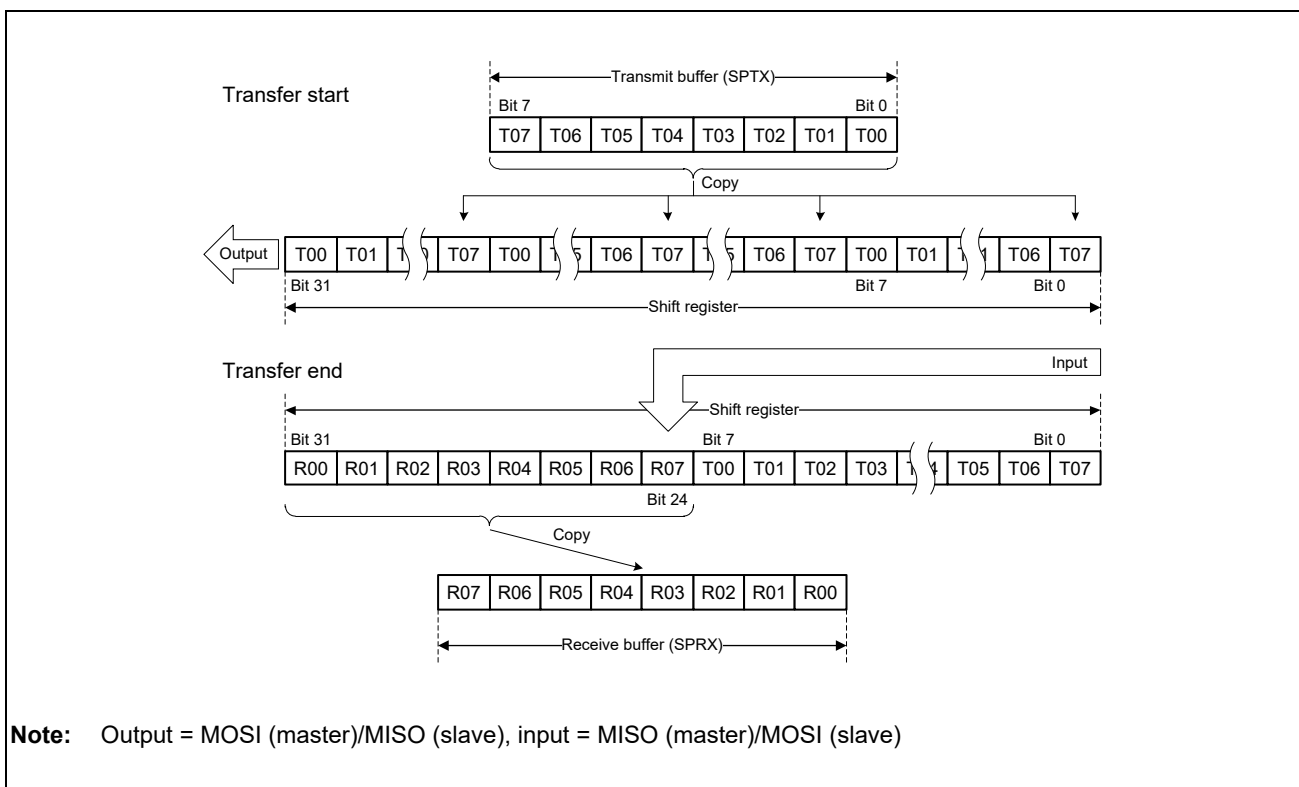

Figure 24.13 LSB First Transfer (8-Bit Data)

24.4.6 Error Detection

In the normal serial transfer, the data written to the transmit buffer of the data register (SPDR) is serially transmitted, and the serially received data can be read from the receive buffer of SPDR. If access is made to SPDR, depending on the status of the transmit buffer/receive buffer or the status at the beginning or end of serial transfer, in some cases non-normal transfers can be executed.

If a non-normal transfer operation occurs, this module detects the event as an overrun error or a mode fault error. **Table 24.7** shows the relationship between non-normal transfer operations and the error detection function.

Table 24.7 Relationship between Non-Normal Transfer Operations and Error Detection Function

	Occurrence Condition	Operation	Error Detection
A	SPDR is written when the transmit buffer is full.	Missing write data.	None
B	Serial transfer is started in slave mode when transmit data is still not loaded on the shift register.	Data received in previous serial transfer is serially transmitted.	None
C	SPDR is read when the receive buffer is empty.	The output data is undefined.	None
D	Serial transfer terminates when the receive buffer is full.	Missing serial receive data.	Overrun error (only in slave mode)
E	The SSL input signal is negated during serial transfer in slave mode.	Serial transfer suspended. Missing send/receive data. Operation disabled.	Mode fault error

On operation A shown in **Table 24.7**, this module does not detect an error. Whether SPDR can be written to or not can be checked using the T[3:0] bits in the buffer data count setting register (SPBFDR).

Likewise, this module does not detect an error on operation B. In a serial transfer that was started before the shift register was updated, this module sends the data that was received in the previous serial transfer, and does not treat the operation indicated in B as an error. Note that the received data from the previous serial transfer is retained in the receive buffer of SPDR, thus it can be correctly read.

Similarly, this module does not detect an error on operation C. To prevent extraneous data from being read, the number of receive data units stored in the receive buffer should be read from the R[5:0] bits in the buffer data count setting register (SPBFDR).

An overrun error shown in D is described in **Section 24.4.6(1), Overrun Error**. A mode fault error shown in E is described in **Section 24.4.6(2), Mode Fault Error**.

(1) Overrun Error

If serial transfer ends when the receive buffer of the data register (SPDR) is full, this module detects an overrun error, and sets the OVRF bit in SPSR to 1. When the OVRF bit is 1, this module does not copy data from the shift register to the receive buffer so that the data prior to the occurrence of the error is retained in the receive buffer. To reset the OVRF bit in SPSR to 0, either perform a power-on reset, or write a 0 to the OVRF bit after SPSR has been read with the OVRF bit set to 1.

Figure 24.14 shows an example of operation of the SPRF and OVRF bits in SPSR. The SPSR and SPDR accesses shown in **Figure 24.14** indicate the condition of accesses to SPSR and SPDR, respectively, where I denotes an idle cycle, W a write cycle, and R a read cycle. In the example of **Figure 24.14**, this module performs an 8-bit serial transfer in which the CPHA bit in the command register (SPCMD) is 1, and CPOL is 0. The numbers given under the RSPCK waveform represent the number of RSPCK cycles (i.e., the number of transferred bits).

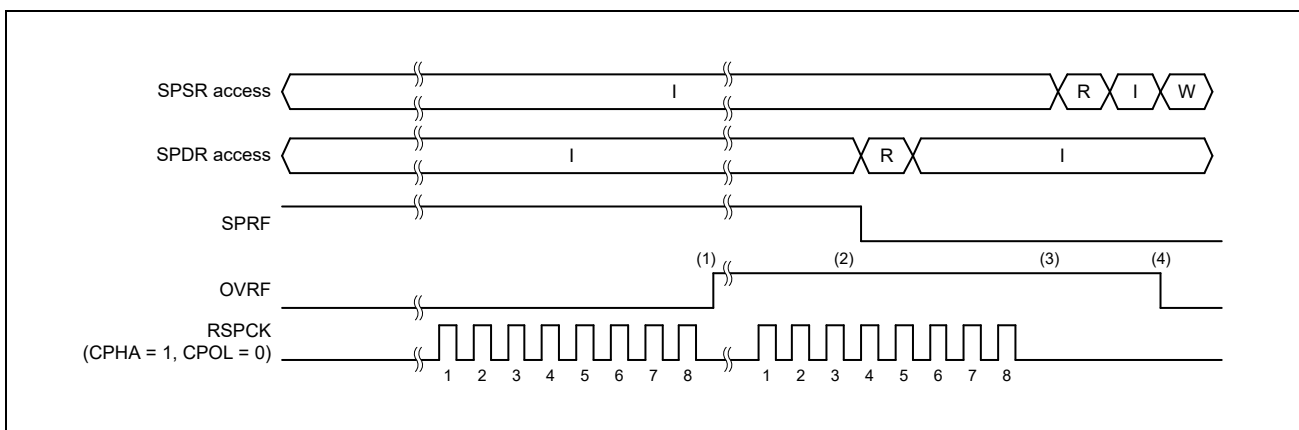

Figure 24.14 SPRF and OVRF Bit Operation Example

The operation of the flags at the timing shown in steps (1) to (4) in the figure is described below.

1. If a serial transfer terminates when the receive buffer does not have a space for the receive data length, this module detects an overrun error, and sets the OVRF bit to 1. This module does not copy the data in the shift register to the receive buffer.
2. The OVRF bit is not cleared even when SPDR is read and thus the number of data bytes in the receive buffer becomes less than the number of the receive buffer data triggering number specified by the RXTRG bits.
3. If the serial transfer terminates in an overrun error state, this module determines that the shift register is empty; in this manner, data transfer is enabled from the transmit buffer to the shift register.
4. If 0 is written to the OVRF bit after SPSR is read with OVRF = 1, this module clears the OVRF bit.

The occurrence of an overrun can be checked either by reading SPSR or by using an error interrupt and reading SPSR. When using an error interrupt, set the SPEIE bit in the control register (SPCR) to 1. When executing a serial transfer without using an error interrupt, measures should be taken to ensure the early detection of overrun errors, such as reading SPSR immediately after SPDR is read.

The OVRF bit is cleared to 0 under the following conditions:

- After SPSR is read in a condition in which the OVRF bit is set to 1, 0 is written to the OVRF bit.
- Power-on reset

NOTE

When the receive buffer has area enough to store receive data with an overrun error, this module receives receive data.

(2) Mode Fault Error

When the MSTR bit is 0, this module operates in slave mode. This module detects a mode fault error if the SSL input signal is negated during the serial transfer period (from the time the driving of valid data is started to the time the final valid data is fetched) when the MODFEN bit is 1 in slave mode.

Upon detecting a mode fault error, this module stops driving of the output signals and clears the SPE bit in SPCR to 0. When the SPE bit is cleared to 0, the function of this module is disabled, and this module stops driving external signals. For details of disabling the function of this module by clearing the SPE bit to 0, see **Section 24.4.7, Initialization**.

The occurrence of a mode fault error can be checked either by reading SPSR or by using an error interrupt and reading SPSR. When using an error interrupt, set the SPEIE bit in the control register (SPCR) to 1. To detect a mode fault error without using an error interrupt, it is necessary to poll SPSR.

When the MODF bit is 1, writing 1 to the SPE bit is ignored. To enable the function of this module after the detection of a mode fault error, the MODF bit must be set to 0. The MODF bit is cleared to 0 under the following conditions:

- After SPSR is read in a condition where the MODF bit has turned 1, 0 is written to the MODF bit.
- Power-on reset

24.4.7 Initialization

If 0 is written to the SPE bit in the control register (SPCR) or this module clears the SPE bit to 0 because of the detection of a mode fault error, this module disables the module function, and initializes a part of the module function. When a power-on reset is generated, this module initializes all of the module function. An explanation follows of initialization by the clearing of the SPE bit.

(1) Initialization by Clearing SPE Bit

When the SPE bit in SPCR is cleared, this module performs the following initialization:

- Suspending any serial transfer that is being executed
- Stopping the driving of output signals (Hi-Z) in slave mode
- Initializing the internal state
- Initializing the TEND bit in SPSR

Initialization by the clearing of the SPE bit does not initialize the control bits of this module. For this reason, this module can be started in the same transfer mode as prior to the initialization if the SPE bit is re-set to 1.

24.4.8 SPI Operation

(1) Multi-Master Mode Operation

This section explains the operation in multi-master mode.

(a) Starting Serial Transfer

A serial transfer is started when transmit data is copied from the transmit buffer to the shift register, the shift register becomes full, and the receive buffer has a space for the receive data length. If transmit data has already been written to the shift register, data is not copied from the transmit buffer to the shift register.

For details of the transfer format, see **Section 24.4.4, Transfer Format**.

(b) Terminating Serial Transfer

Irrespective of the CPHA bit in the command register (SPCMD), this module terminates the serial transfer after transmitting an RSPCK edge corresponding to the final sampling timing. After the serial transfer is completed, receive data is copied from the shift register to the receive buffer. If the receive buffer does not have a space for the receive data length after receive data is copied from the shift register to the receive buffer, another serial transfer will not be performed. In order to perform another serial transfer, data for the receive data length should be read from the receive buffer to secure the space for the receive data.

It should be noted that the final sampling timing varies depending on the bit length of transfer data. In master mode, the data length depends on the settings in bits SPB3 to SPB0 in SPCMD. For details on the transfer format, see **Section 24.4.4, Transfer Format**.

(c) Sequence Control

The transfer format that is employed in master mode is determined by the sequence control register (SPSCR), command registers 0 to 3 (SPCMD0 to SPCMD3), the bit rate register (SPBR), the clock delay register (SPCKD), the slave select negation delay register (SSLND), and the next-access delay register (SPND).

SPSCR is a register used to determine the sequence configuration for serial transfers that are executed by this module in master mode. The following items are set in command registers SPCMD0 to SPCMD3: SSL output signal value, MSB/LSB first, data length, some of the bit rate settings, RSPCK polarity/phase, whether SPCKD is to be referenced, whether SSLND is to be referenced, and whether SPND is to be referenced. SPBR holds some of the bit rate settings; SPCKD, a clock delay value; SSLND, an SSL negation delay; and SPND, a next-access delay value.

According to the sequence length that is assigned to SPSCR, this module makes up a sequence comprised of a part or all of SPCMD0 to SPCMD3. This module contains a pointer to the SPCMD that makes up the sequence. The value of this pointer can be checked by reading bits SPCP1 and SPCP0 in the sequence status register (SPSSR). When the SPE bit in the control register (SPCR) is set to 1 and the function of this module is enabled, this module loads the pointer to the commands in SPCMD0, and incorporates the SPCMD0 settings into the transfer format at the beginning of serial transfer. This module increments the pointer each time the next-access delay period for a data transfer ends. Upon completion of the serial transfer that corresponds to the final command comprising the sequence, this module sets the pointer in SPCMD0, and in this manner the sequence is executed repeatedly.

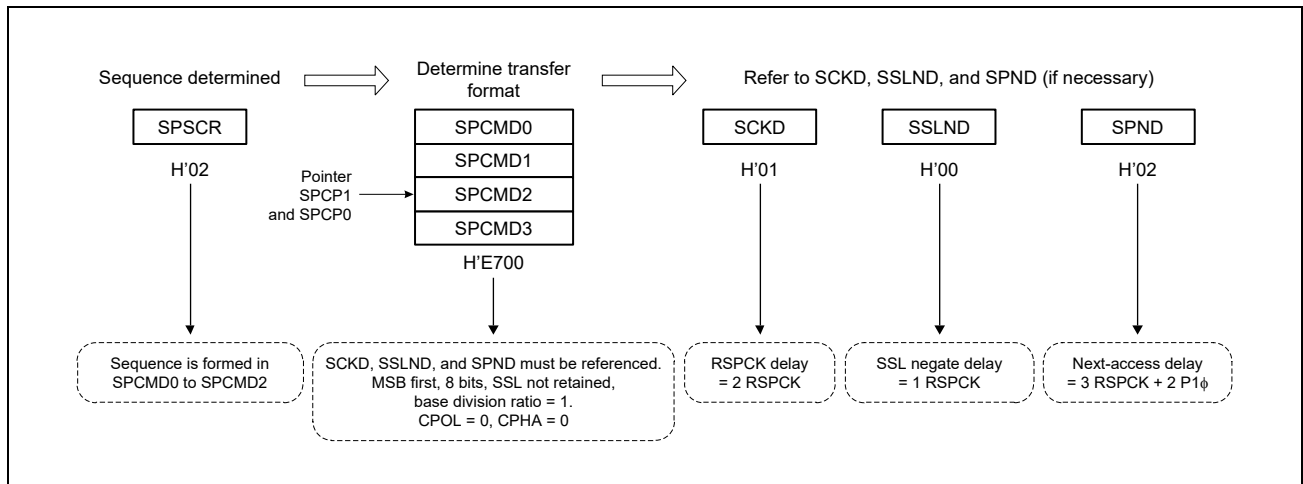

Figure 24.15 Determination Procedure of Serial Transfer Mode in Master Mode

(d) Burst Transfer

If the SSLKP bit in the command register (SPCMD) that this module references during the current serial transfer is 1, this module keeps the SSL signal level during the serial transfer until the beginning of the SSL signal assertion for the next serial transfer. If the SSL signal level for the next serial transfer is the same as the SSL signal level for the current serial transfer, this module can execute continuous serial transfers while keeping the SSL signal assertion status (burst transfer).

Figure 24.16 shows an example of an SSL signal operation for the case where a burst transfer is implemented using SPCMD0 and SPCMD1 settings. The text below explains operations (1) to (7) as depicted in **Figure 24.16**. It should be noted that the polarity of the SSL output signal depends on the settings in the slave select polarity register (SSLP).

1. Based on SPCMD0, this module asserts the SSL signal and inserts RSPCK delays.
2. Serial transfers are executed according to SPCMD0.
3. SSL negation delays are inserted.
4. Because the SSLKP bit in SPCMD0 is 1, this module keeps the SSL signal value on SPCMD0. This period is sustained, at the shortest, for a period equal to the next-access delay of SPCMD0. If the shift register is empty after the passage of a minimum period, this period is sustained until such time as the transmit data is stored in the shift register for another transfer.
5. Based on SPCMD1, this module asserts the SSL signal and inserts RSPCK delays.
6. Serial transfers are executed according to SPCMD1.
7. Because the SSLKP bit in SPCMD1 is 0, this module negates the SSL signal. In addition, a next-access delay is inserted according to SPCMD1.

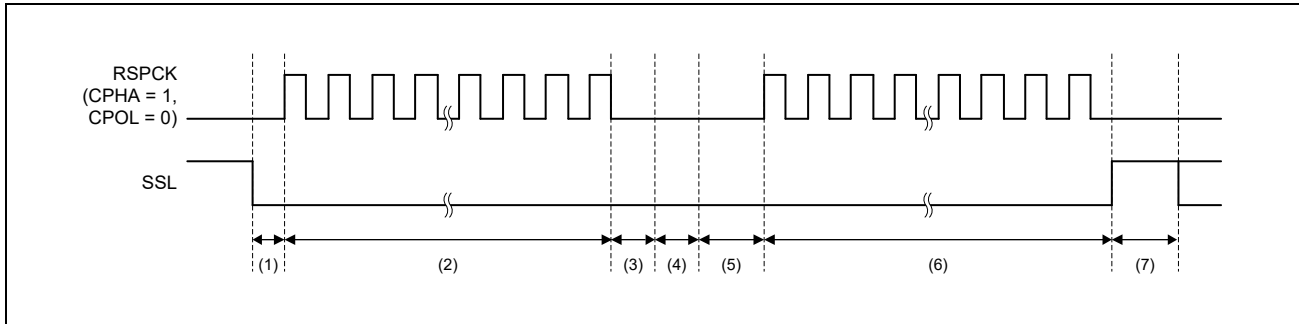

Figure 24.16 Example of Burst Transfer Operation using SSLKP Bit

If the SSL signal settings in the SPCMD in which 1 is assigned to the SSLKP bit are different from the SSL signal output settings in the SPCMD to be used in the next transfer, this module switches the SSL signal status to SSL signal assertion ((5) in **Figure 24.16**) corresponding to the command for the next transfer. Notice that if such an SSL signal switching occurs, the slaves that drive the MISO signal compete, and the possibility arises of the collision of signal levels.

This module in master mode references within the module the SSL signal operation for the case where the SSLKP bit is not used. Even when the CPHA bit in SPCMD is 0, this module can accurately start serial transfers by asserting the SSL signal for the next transfer. For this reason, burst transfers in master mode can be executed irrespective of CPHA bit settings (see **Section 24.4.8(2), Slave Mode Operation**).

(e) RSPCK Delay (t1)

The RSPCK delay value in master mode depends on SCKDEN bit settings in the command register (SPCMD) and on clock delay register (SPCKD) settings. This module determines the SPCMD to be referenced during serial transfer by pointer control, and determines an RSPCK delay value during serial transfer by using the SCKDEN bit in the selected SPCMD and SPCKD, as shown in **Table 24.8**. For a definition of RSPCK delay, see **Section 24.4.4, Transfer Format**.

Table 24.8 Relationship among SCKDEN and SPCKD Settings and RSPCK Delay Values

SCKDEN	SPCKD	RSPCK Delay Value
0	000 to 111	1 RSPCK
1	000	1 RSPCK
	001	2 RSPCK
	010	3 RSPCK
	011	4 RSPCK
	100	5 RSPCK
	101	6 RSPCK
	110	7 RSPCK
	111	8 RSPCK

(f) SSL Negation Delay (t2)

The SSL negation delay value in master mode depends on SLNDEN bit settings in the command register (SPCMD) and on SSL negation delay register (SSLND) settings. This module determines the SPCMD to be referenced during serial transfer by pointer control, and determines an SSL negation delay value during serial transfer by using the SLNDEN bit in the selected SPCMD and SSLND, as shown in **Table 24.9**. For a definition of SSL negation delay, see **Section 24.4.4, Transfer Format**.

Table 24.9 Relationship among SLNDEN and SSLND Settings and SSL Negation Delay Values

SLNDEN	SSLND	SSL Negation Delay Value
0	000 to 111	1 RSPCK
1	000	1 RSPCK
	001	2 RSPCK
	010	3 RSPCK
	011	4 RSPCK
	100	5 RSPCK
	101	6 RSPCK
	110	7 RSPCK
	111	8 RSPCK

(g) Next-Access Delay (t3)

The next-access delay value in master mode depends on SPNDEN bit settings in the command register (SPCMD) and on next-access delay register (SPND) settings. This module determines the SPCMD to be referenced during serial transfer by pointer control, and determines a next-access delay value during serial transfer by using the SPNDEN bit in the selected SPCMD and SPND, as shown in **Table 24.10**. For a definition of next-access delay, see **Section 24.4.4, Transfer Format**.

Table 24.10 Relationship among SPNDEN and SPND Settings and Next-Access Delay Values

SPNDEN	SPND	Next-Access Delay Value
0	000 to 111	1 RSPCK + 2 P0φ
1	000	1 RSPCK + 2 P0φ
	001	2 RSPCK + 2 P0φ
	010	3 RSPCK + 2 P0φ
	011	4 RSPCK + 2 P0φ
	100	5 RSPCK + 2 P0φ
	101	6 RSPCK + 2 P0φ
	110	7 RSPCK + 2 P0φ
	111	8 RSPCK + 2 P0φ

(h) Initialization Flowchart

Figure 24.17 is a flowchart illustrating an example of initialization in SPI operation when this module is used in master mode. For a description of how to set up the interrupt controller, direct memory access controller, and input/output ports, see the descriptions given in the individual blocks.

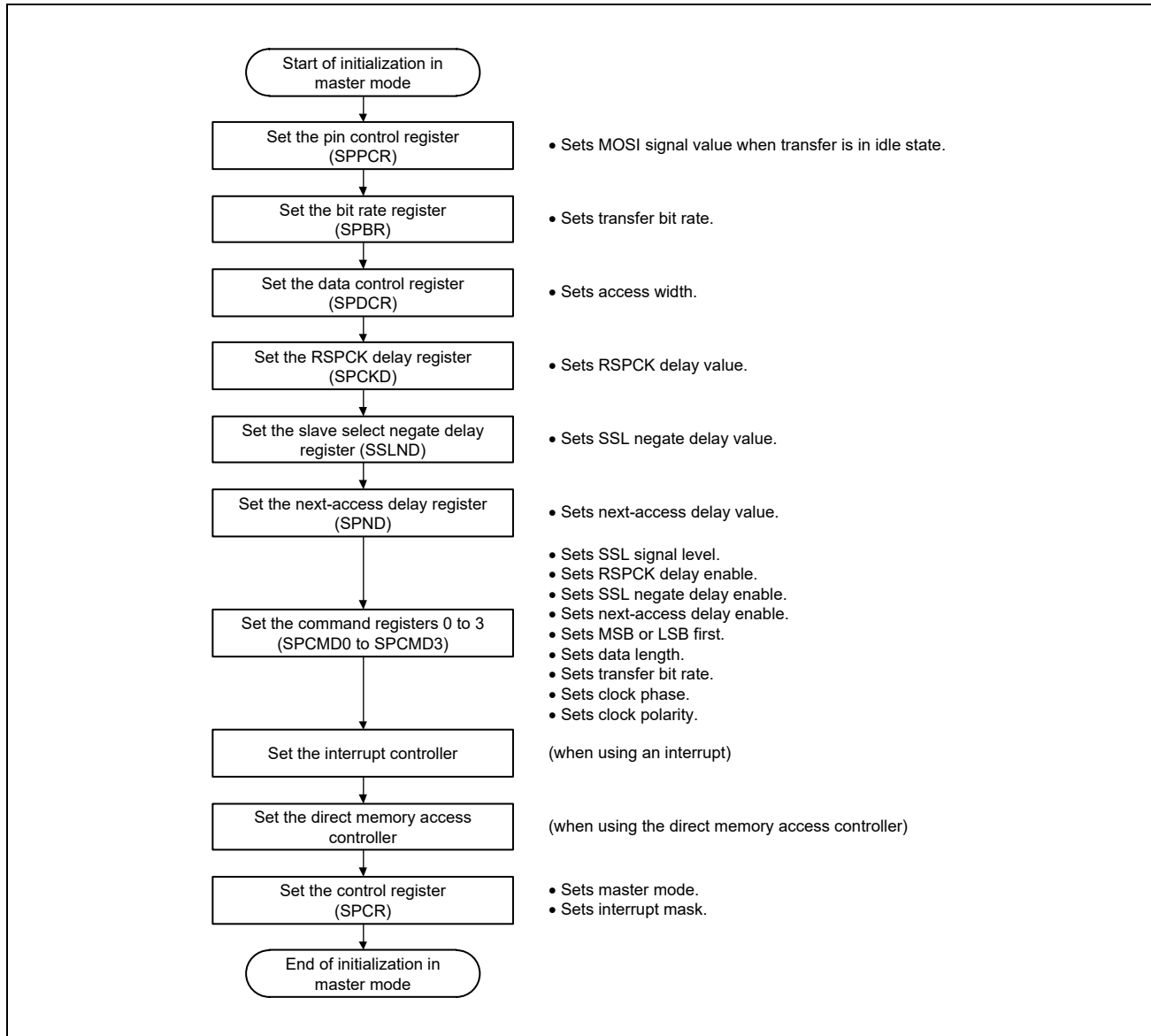

Figure 24.17 Example of Initialization Flowchart in Master Mode

(i) Transfer Operation Flowchart

Figure 24.18 is a flowchart illustrating a transfer in SPI operation when this module is used in master mode.

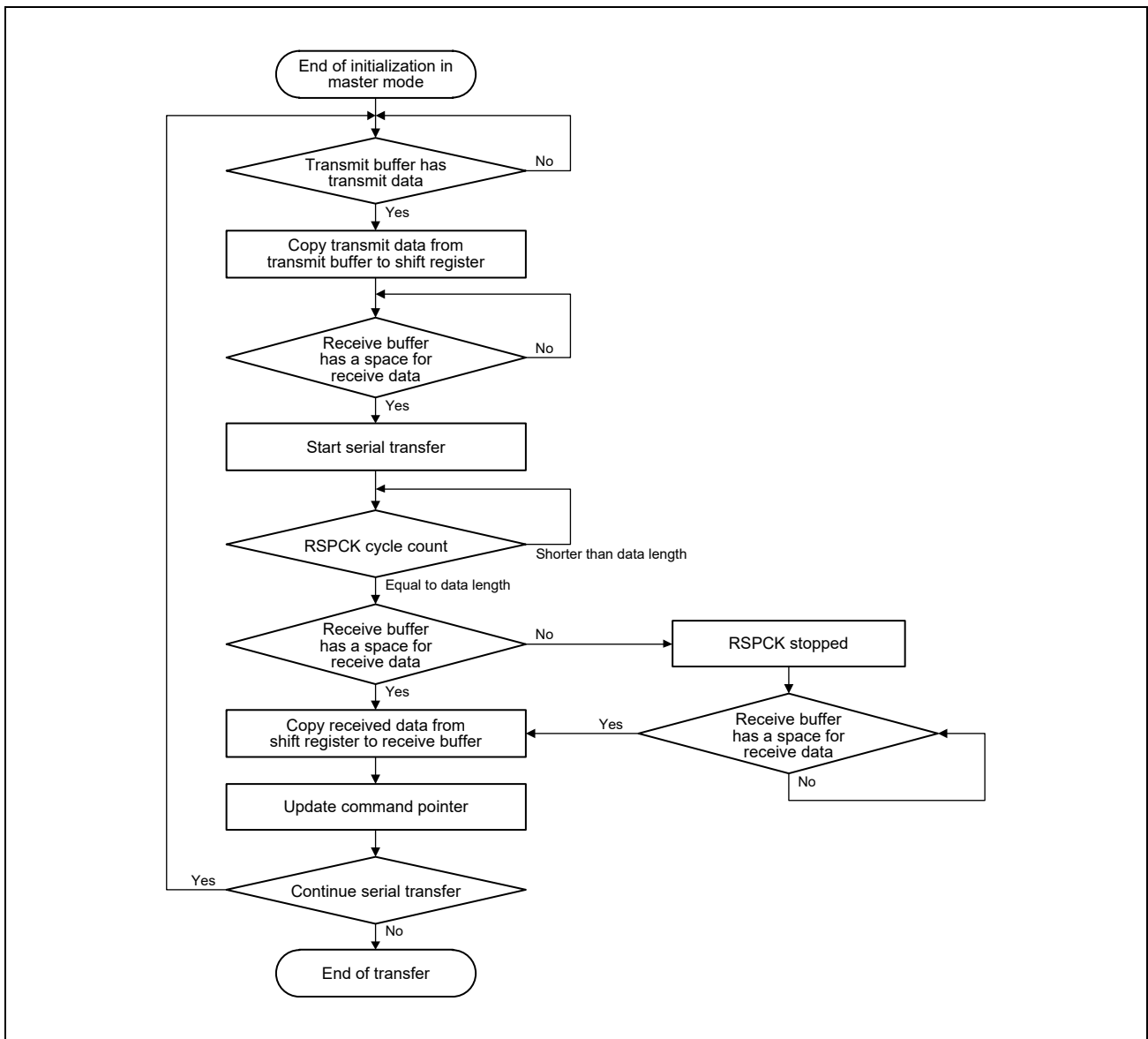

Figure 24.18 Transfer Operation Flowchart in Master Mode

(2) Slave Mode Operation

(a) Starting Serial Transfer

If this module detects an SSL input signal assertion when the CPHA bit in the command register 0 (SPCMD0) is 0, this module is required to start driving valid data to the MISO output signal. For this reason, when the CPHA bit is 0, the asserting of the SSL input signal triggers the start of a serial transfer.

If this module detects the first RSPCK edge in an SSL signal asserted condition when the CPHA bit is 1, this module is required to start driving valid data to the MISO output signal. For this reason, when the CPHA bit is 1, the first RSPCK edge in an SSL signal asserted condition triggers the start of a serial transfer.

When detecting the start of a serial transfer in a condition in which the shift register is empty, this module changes the status of the shift register to “full”, so that data cannot be copied from the transmit buffer to the shift register when serial transfer is in progress. If the shift register was full before the serial transfer started, this module leaves the status of the shift register intact, in the full state.

Irrespective of CPHA bit settings, this module starts driving MISO output signals at the SSL signal assertion timing. Whether the data output from this module is valid or invalid differs depending on CPHA bit settings.

For details on the transfer format, see **Section 24.4.4, Transfer Format**. The polarity of the SSL input signal depends on the setting of the SSL0P bit in the slave select polarity register (SSLP).

(b) Terminating Serial Transfer

Irrespective of the CPHA bit in the command register 0 (SPCMD0), this module terminates the serial transfer after detecting an RSPCK edge corresponding to the final sampling timing. When the receive buffer has an enough space for receive data, this module copies received data from the shift register to the receive buffer of the data register (SPDR) upon termination of the serial transfer. Irrespective of the value of the SPRF bit, this module changes the status of the shift register to “empty” upon termination of the serial transfer. If this module detects an SSL input signal negation from the beginning of serial transfer to the end of serial transfer, a mode fault error occurs (see **Section 24.4.6, Error Detection**).

The final sampling timing changes depending on the bit length of the transfer data. In slave mode, the data length depends on the settings in bits SPB3 to SPB0 bits in SPCMD0. The polarity of the SSL input signal depends on the setting in the SSL0P bit in the slave select polarity register (SSLP). For details on the transfer format, see **Section 24.4.4, Transfer Format**.

(c) Notes on Slave Operations

If the CPHA bit in the command register 0 (SPCMD0) is 0, this module starts serial transfers when it detects the assertion edge for an SSL input signal. In the type of configuration shown in **Figure 24.4** as an example, if this module is used in single-slave mode, the SSL signal is always fixed at active state. Therefore, when the CPHA bit is set to 0, this module cannot correctly start a serial transfer. To correctly execute send/receive operation in a configuration in which the SSL input signal is fixed at active state, the CPHA bit should be set to 1. When it is necessary to set the CPHA bit to 0, the SSL input signal should not be fixed.

(d) Burst Transfer

If the CPHA bit in the command register 0 (SPCMD0) is 1, continuous serial transfer (burst transfer) can be executed while retaining the assertion state for the SSL input signal. If the CPHA bit is 1, the period from the first RSPCK edge to the sampling timing for the reception of the final bit in an SSL signal active state corresponds to a serial transfer period. Even when the SSL input signal remains at the active level, this module can accommodate burst transfers because it can detect the start of access.

If the CPHA bit is 0, for the reason given in **Section 24.4.8(2)(c), Notes on Slave Operations**, second and subsequent serial transfers during the burst transfer cannot be executed correctly.

(e) Initialization Flowchart

Figure 24.19 is a flowchart illustrating an example of initialization in SPI operation when this module is used in slave mode. For a description of how to set up the interrupt controller, direct memory access controller, and input/output ports, see the descriptions given in the individual blocks.

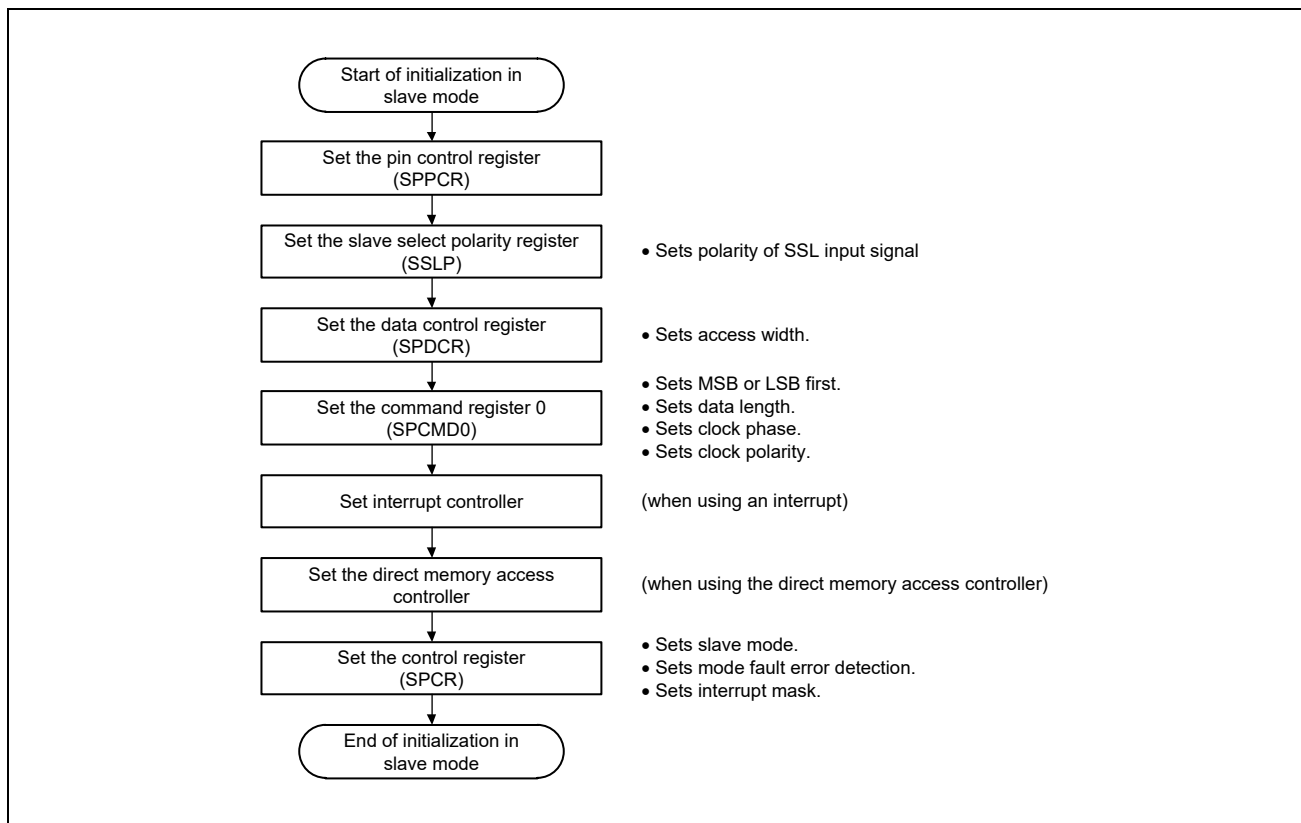

Figure 24.19 Example of Initialization Flowchart in Slave Mode

(f) Transfer Operation Flowchart (CPHA = 0)

Figure 24.20 is a flowchart illustrating a transfer in SPI operation when this module is used in slave mode with the CPHA bit in the command register 0 (SPCMD0) set to 0.

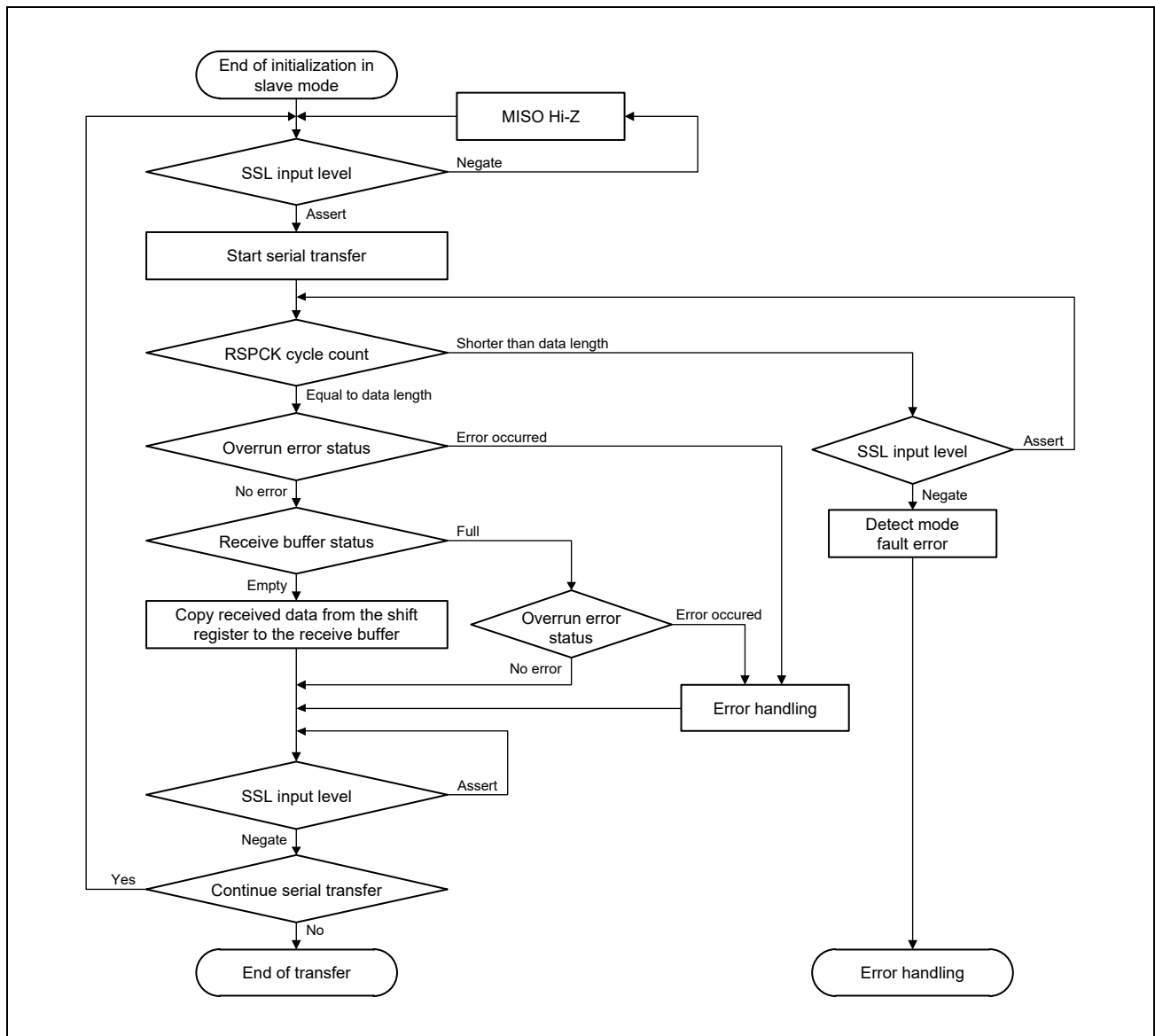

Figure 24.20 Transfer Operation Flowchart in Slave (CPHA = 0)

(g) Transfer Operation Flowchart (CPHA = 1)

Figure 24.21 is a flowchart illustrating a transfer in SPI operation when this module is used in slave mode with the CPHA bit in the command register 0 (SPCMD0) and the MODFEN bit in the control register (SPCR) set to 1, respectively. The subsequent operation is not guaranteed when the serial transfer is started with the MODFEN bit set to 0 and the SSL input level is negated with the number of RSPCK cycles shorter than the data length.

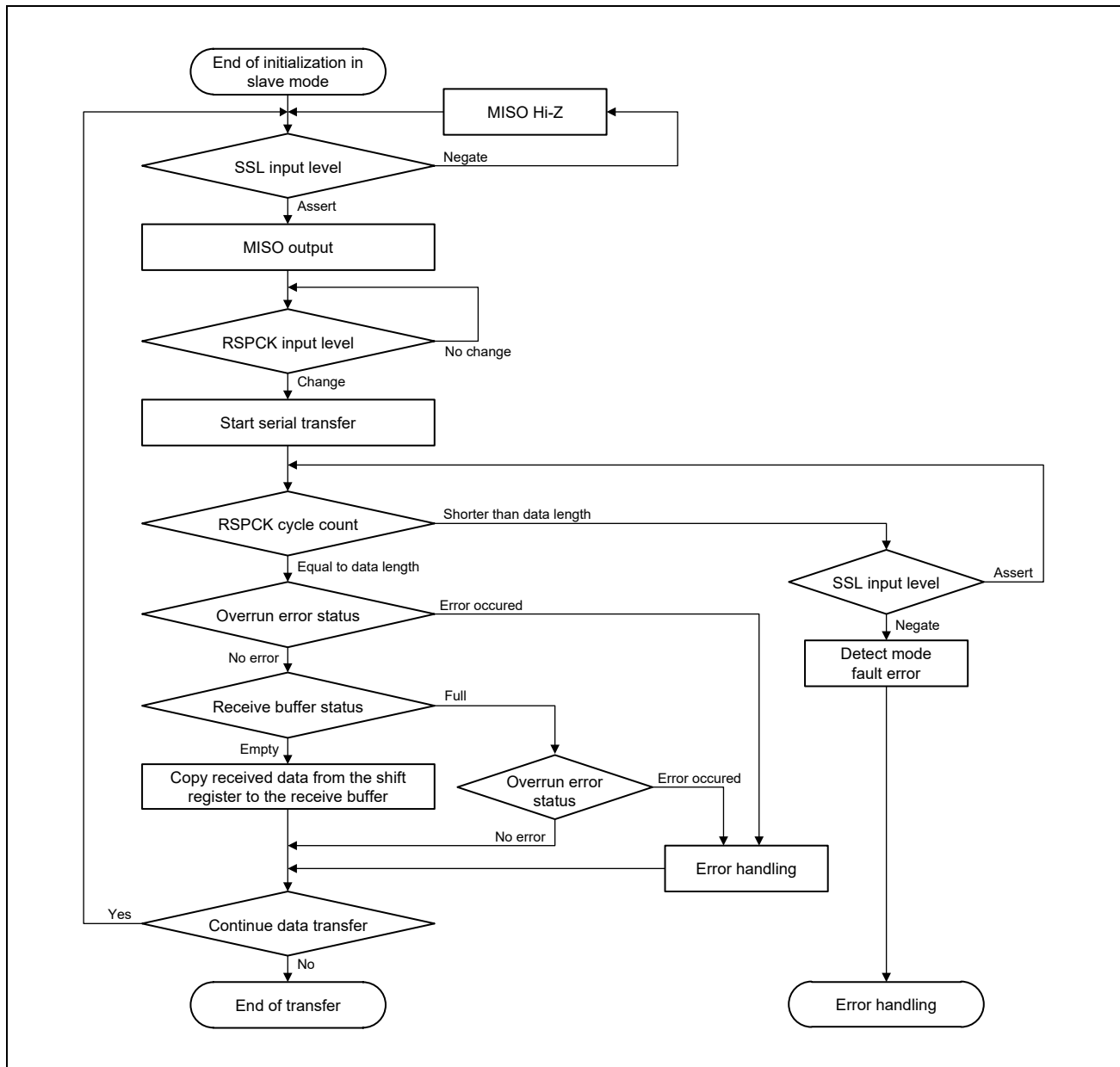

Figure 24.21 Transfer Operation Flowchart in Slave Mode (CPHA = 1)

24.4.9 Error Handling

Figure 24.22 and Figure 24.23 show the error handling. The following error handling is used to return from the error state after an error in master or slave mode.

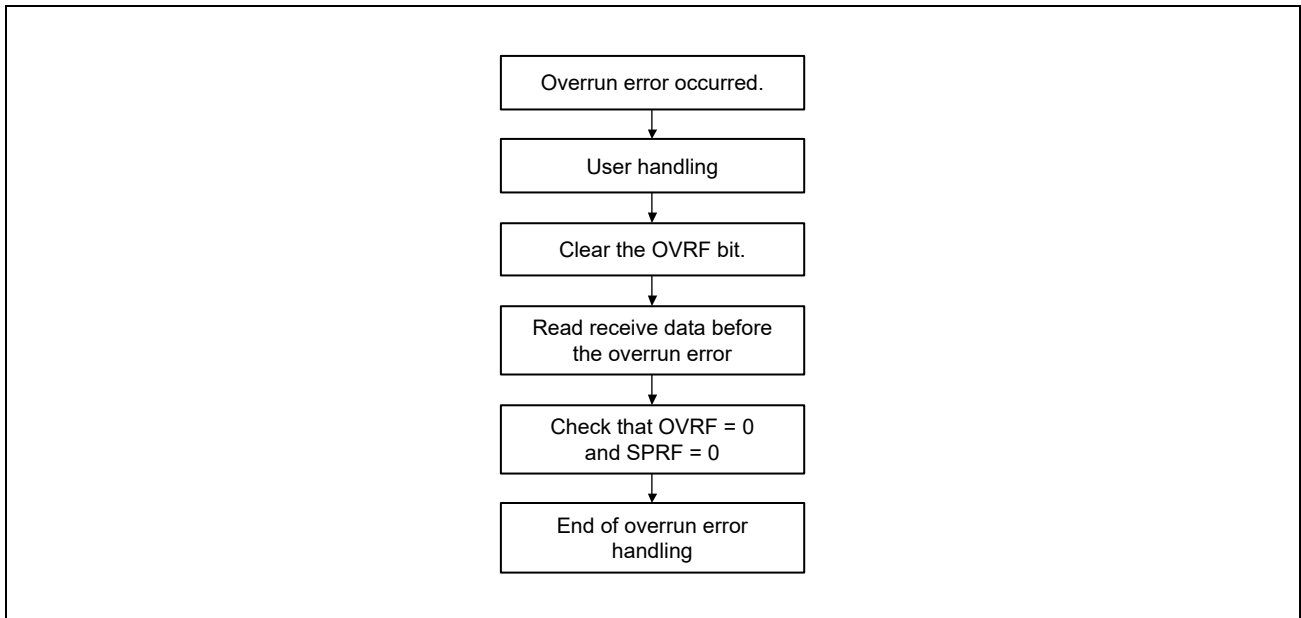

Figure 24.22 Error Handling (Overrun Error)

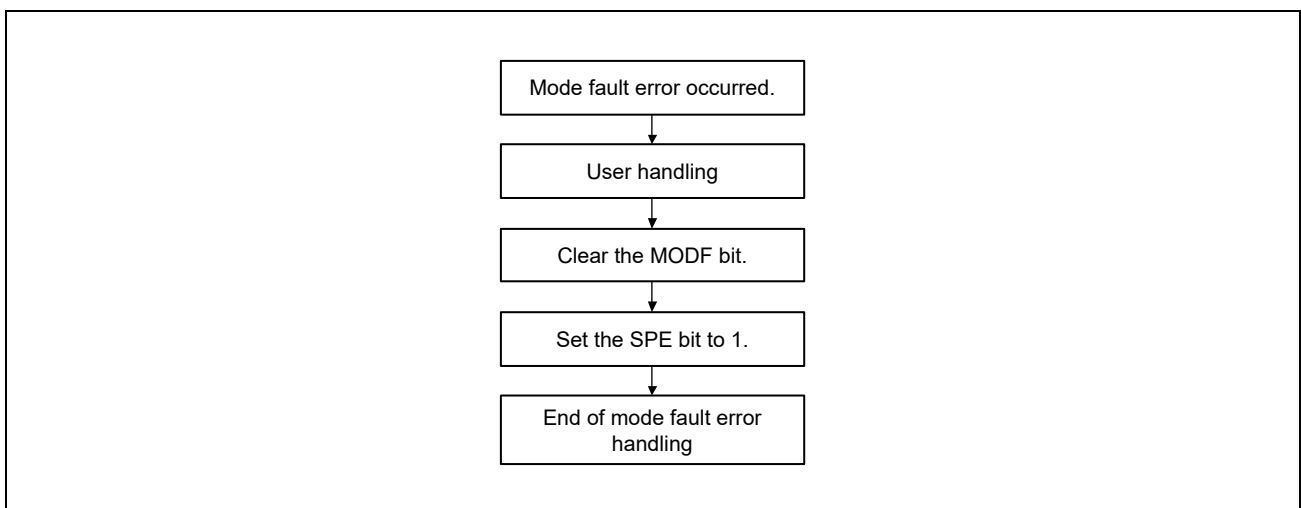

Figure 24.23 Error Handling (Mode Fault Error)

24.4.10 Loopback Mode

When 1 is written to the SPLP bit in the pin control register (SPPCR), this module shuts off the path between the MISO pin and the shift register, and between the MOSI pin and the shift register, and connects the input path and the output path (reversed) of the shift register. This is called loopback mode. When a serial transfer is executed in loopback mode, the transmit data becomes the received data. **Figure 24.24** shows the configuration of the shift register input/output paths for the case where this module in master mode is set in loopback mode.

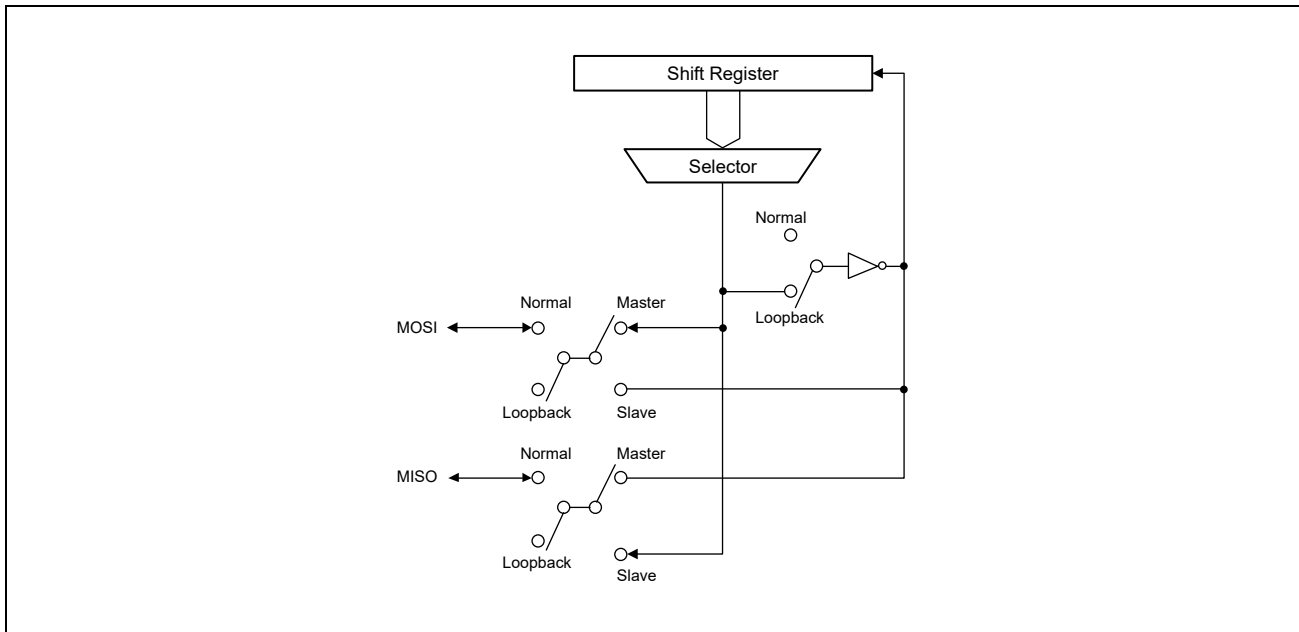

Figure 24.24 Configuration of Shift Register Input/Output Paths in Loopback Mode (Master Mode)

24.4.11 Interrupt Sources

This module has interrupt sources of receive buffer full, transmit buffer empty, mode fault, and overrun. In addition, the direct memory access controller can be activated by the receive buffer full or transmit buffer empty interrupt for data transfer.

Table 24.11 shows the interrupt sources.

When any of the interrupt conditions in **Table 24.11** is met, an interrupt is generated. The interrupt sources should be cleared with data transfer by the CPU or direct memory access controller.

Table 24.11 Interrupt Sources

Name	Interrupt Source	Abbreviation	Interrupt Condition	Activation of Direct Memory Access Controller
SPRI	Receive buffer full	RXI	$(SPRIE = 1) \cdot (SPRF = 1)$	Possible
SPTI	Transmit buffer empty	TXI	$(SPTIE = 1) \cdot (SPTEF = 1)$	Possible
SPEI	Mode fault	MOI	$(SPEIE = 1) \cdot (MODF = 1)$	—
	Overrun	OVI	$(SPEIE = 1) \cdot (OVRF = 1)$	—

25. SPI Multi I/O Bus Controller

The SPI multi I/O bus controller enables the direct connection of serial flash memory device to this LSI chip.

25.1 Features

This module allows the connected serial flash memory device to be accessed by reading the external address space, or using Manual mode to transmit and receive data.

25.1.1 Serial Flash Memory Interface

- SPI_PVDD: 1.8V/3.3V
- QSPI0_SPCLK: 66MHz (SDR), 50MHz (DDR)
- A data bus size of 1 bit or 4 bits can be selected for one serial flash memory device.
- Both single data rate (SDR) and double data rate (DDR) transfers are supported.
- Supports master operation. (Slave operation is not supported.)

25.1.2 External Address Space Read Mode

- Read access from the bus master to the SPI multi I/O space is automatically converted to a read command, and the read data is returned to the bus master.
- Normal read operation and burst read operation
- Efficient data reception due to built-in read cache (64-bit line × 32 entries)

25.1.3 Manual Mode

- Read and write commands are available for serial flash memory.
- A write buffer is provided to improve the efficiency of data write operations.
- The cache is not usable for reading.

25.2 Block Diagram

Figure 25.1 shows a block diagram of this module.

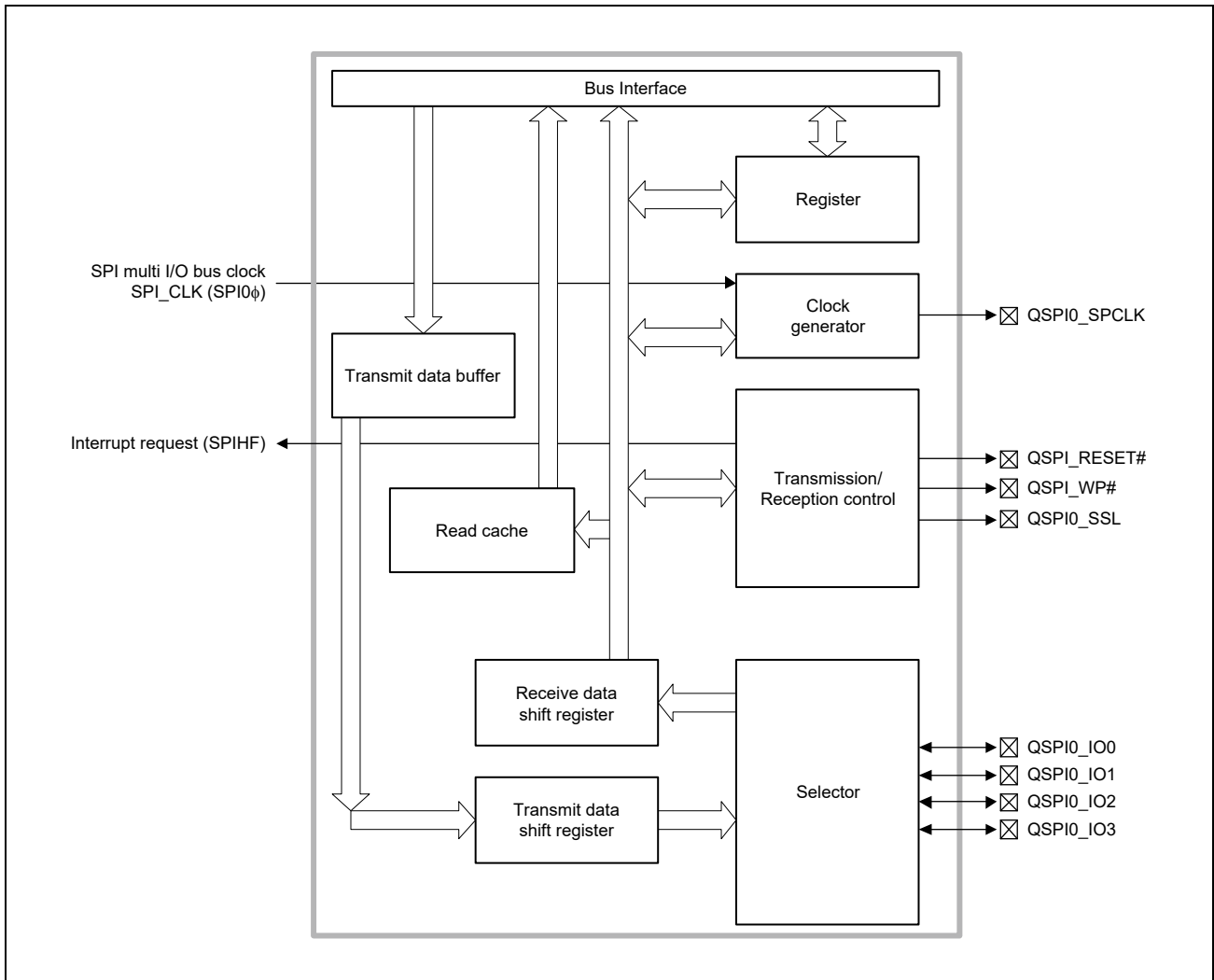

Figure 25.1 Block Diagram

25.3 Input/Output Pins

Table 25.1 shows the pin configuration for one channel.

The operating voltage on pins of the SPI multi I/O bus controller is 3.3 V or 1.8 V.

Before using the pins of the SPI multi I/O bus controller, be sure to set up the QSPI IO Voltage Control Register(QSPI) and Driving Ability Control Register (IOLH).

For details, see **Section 41.3.19, QSPI IO Voltage Control Register(QSPI)** and **Section 41.3.7, Driving Ability Control Register(IOLH)**.

Table 25.1 Pin Configuration

Pin Name	Symbol	I/O	One 4-bit Serial Flash connected. CMNCR.BSZ = 00
Clock* ¹	QSPI0_SPCLK* ³	Output	SCK
Data 0* ¹	QSPI0_IO0	I/O	SI/IO0
Data 1* ¹	QSPI0_IO1	I/O	SO/IO1
Data 2* ¹	QSPI0_IO2	I/O	WP#/IO2
Data 3* ¹	QSPI0_IO3	I/O	HOLD#/IO3
Slave select* ¹	QSPI0_SSL	Output	CS#
Reset* ²	QSPI_RESET#	Output	RESET#
Write protect* ²	QSPI_WP#	Output	For one 1-bit serial flash memory: WP#/IO2

Note 1. When connecting a serial flash memory device with the BSZ[1:0] bits set to 00, connect the serial flash memory to the QSPI0 pin group of this LSI.

Note 2. These pin connections must meet to the flash specifications.

Note 3. QSPI0_SPCLK is one-half frequency of SPI0φ.

25.4 Register Descriptions

Table 25.2 shows the register configuration.

Base Address: H'0_1006_0000 (AX45MP Address Space)

Table 25.2 Register Configuration

Register Name	Abbreviation	R/W	Initial Value	Address	Access Size
Common control register	CMNCR	R/W	H'01557301	H'0000	32
SSL delay register	SSLDR	R/W	H'00000000	H'0004	32
Data read control register	DRCR	R/W	H'001F0100	H'000C	32
Data read command setting register	DRCMR	R/W	H'00A00000	H'0010	32
Data read extended address setting register	DREAR	R/W	H'00000000	H'0014	32
Data read option setting register	DROPR	R/W	H'00000000	H'0018	32
Data read enable setting register	DRENR	R/W	H'A222D400	H'001C	32
Manual mode control register	SMCR	R/W	H'00000000	H'0020	32
Manual mode command setting register	SMCMR	R/W	H'00000000	H'0024	32
Manual mode address setting register	SMADR	R/W	H'00000000	H'0028	32
Manual mode option setting register	SMOPR	R/W	H'00000000	H'002C	32
Manual mode enable setting register	SMENR	R/W	H'00004000	H'0030	32
Manual mode read data register 0	SMRDR0	R	Undefined	H'0038	8, 16, 32
Manual mode write data register 0	SMWDR0	R/W	H'00000000	H'0040	8, 16, 32
Common status register	CMNSR	R	H'00000001	H'0048	32
Data read dummy cycle setting register	DRDMCR	R/W	H'0000000B	H'0058	32
Data read DDR enable register	DRDREN	R/W	H'00005101	H'005C	32
Manual mode dummy cycle setting register	SMDMCR	R/W	H'00000000	H'0060	32
Manual mode DDR enable register	SMDREN	R/W	H'00000000	H'0064	32
PHY control register	PHYCNT	R/W	H'00000263	H'007C	32
PHY offset register 1	PHYOFFSET1	R/W	H'21511144	H'0080	32
PHY offset register 2	PHYOFFSET2	R/W	H'00000431	H'0084	32
PHY interrupt register	PHYINT	R/W	H'07070002	H'0088	32
PHY adjustment register 1	PHYADJ1	R/W	H'00000000	H'0070	32
PHY adjustment register 2	PHYADJ2	R/W	H'00000000	H'0074	32

Note: Do not write to any address those listed in the table. Otherwise, correct operation cannot be guaranteed. Reading from a non-listed address returns an undefined value.

25.4.1 Common Control Register (CMNCR)

CMNCR is a 32-bit register that controls the SPI multi I/O bus controller. The settings of this register are reflected both in external address space read mode and manual mode.

The settings of this register should be changed when the TEND flag in CMNSR is 1; otherwise, the operation cannot be guaranteed.

Bit	31	30	29	28	27	26	25	24	23	22	21	20	19	18	17	16
	MD	—	—	—	—	—	—	—	MOIIIO3[1:0]		MOIIIO2[1:0]		MOIIIO1[1:0]		MOIIIO0[1:0]	
Initial Value	0	0	0	0	0	0	0	1	0	1	0	1	0	1	0	1
R/W	R/W	R	R	R	R	R	R	R	R/W	R/W	R/W	R/W	R/W	R/W	R/W	R/W
Bit	15	14	13	12	11	10	9	8	7	6	5	4	3	2	1	0
	IO3FV[1:0]		IO2FV[1:0]		—	—	IO0FV[1:0]		—	—	—	—	—	—	BSZ[1:0]	
Initial Value	0	1	1	1	0	0	1	1	0	0	0	0	0	0	0	1
R/W	R/W	R/W	R/W	R/W	R	R	R/W	R/W	R	R	R	R	R	R	R/W	R/W

Bit	Bit Name	Initial Value	R/W	Description
31	MD	0	R/W	Operating Mode Switch Switches the operating modes. 0: External address space read mode 1: Manual mode
30 to 25	—	All 0	R	Reserved These bits are always read as 0. The write value should always be 0.
24	—	1	R	Reserved This bit is always read as 1. The write value should always be 1.
23, 22	MOIIIO3[1:0]	01	R/W	QSPIn_SSL Output Idle Value Fix QSPIn_IO3 Fixes the output value on QSPIn_IO3 while QSPIn_SSL is negated. 00: The output value is 0. 01: The output value is 1. 10: The output value is that of the last bit in the previous transfer (the pin is placed in the Hi-Z state if that was the case in the previous transfer). 11: The pin is placed in the Hi-Z state.
21, 20	MOIIIO2[1:0]	01	R/W	QSPIn_SSL Output Idle Value Fix QSPIn_IO2 Fixes the output value on QSPIn_IO2 while QSPIn_SSL is negated. 00: The output value is 0. 01: The output value is 1. 10: The output value is that of the last bit in the previous transfer (the pin is placed in the Hi-Z state if that was the case in the previous transfer). 11: The pin is placed in the Hi-Z state.
19, 18	MOIIIO1[1:0]	01	R/W	QSPIn_SSL Output Idle Value Fix QSPIn_IO1 Fixes the output value on QSPIn_IO1 while QSPIn_SSL is negated. 00: The output value is 0. 01: The output value is 1. 10: The output value is that of the last bit in the previous transfer (the pin is placed in the Hi-Z state if that was the case in the previous transfer). 11: The pin is placed in the Hi-Z state.

Bit	Bit Name	Initial Value	R/W	Description
17, 16	MOII00[1:0]	01	R/W	<p>QSPIn_SSL Output Idle Value Fix QSPIn_IO0</p> <p>Fixes the output value on QSPIn_IO0 while QSPIn_SSL is negated.</p> <p>00: The output value is 0.</p> <p>01: The output value is 1.</p> <p>10: The output value is that of the last bit in the previous transfer (the pin is placed in the Hi-Z state if that was the case in the previous transfer).</p> <p>11: The pin is placed in the Hi-Z state.</p>
15, 14	IO3FV[1:0]	01	R/W	<p>QSPIn_IO3 Fixed Value for 1-bit Size</p> <p>Fixes the output value of QSPIn_IO3 pin for 1-bit size.</p> <p>00: The output value is 0.</p> <p>01: The output value is 1.</p> <p>10: The output value is that of the last bit in the previous transfer (the pin is placed in the Hi-Z state if that was the case in the previous transfer).</p> <p>11: The pin is placed in the Hi-Z state.</p>
13, 12	IO2FV[1:0]	11	R/W	<p>QSPIn_IO2 Fixed Value for 1-bit Size</p> <p>Fixes the output value of QSPIn_IO2 pin for 1-bit size.</p> <p>00: The output value is 0.</p> <p>01: The output value is 1.</p> <p>10: The output value is that of the last bit in the previous transfer (the pin is placed in the Hi-Z state if that was the case in the previous transfer).</p> <p>11: The pin is placed in the Hi-Z state.</p>
11, 10	—	All 0	R	<p>Reserved</p> <p>These bits are always read as 0. The write value should always be 0.</p>
9, 8	IO0FV[1:0]	11	R/W	<p>QSPIn_IO0 Fixed Value for 1-bit Size</p> <p>Fixes the output value of QSPIn_IO0 pin for 1-bit size.</p> <p>00: The output value is 0.</p> <p>01: The output value is 1.</p> <p>10: The output value is that of the last bit in the previous transfer (the pin is placed in the Hi-Z state if that was the case in the previous transfer).</p> <p>11: The pin is placed in the Hi-Z state.</p>
7 to 2	—	All 0	R	<p>Reserved</p> <p>These bits are always read as 0. The write value should always be 0.</p>
1, 0	BSZ[1:0]	01	R/W	<p>Data Bus Size</p> <p>Specifies the number of serial flash memories to be connected.</p> <p>00: one serial flash memory connected</p> <p>01: Setting prohibited</p> <p>1X: Setting prohibited</p> <p><i>Note:</i> After changing (the value of) this bit field, all the entries in the read cache must be cleared by setting the RCF bit in DRCCR to 1.</p>

Note: The settings of the MOII03, MOII02, MOII01, and MOII00 bits for control over fixing the output values are reflected at the time QSPIn_SSL is negated on completion of data transfer.

25.4.2 SSL Delay Register (SSLDLDR)

SSLDLDR is a 32-bit register that adjusts the timing between the QSPIn_SSL signal and the QSPIn_SPCLK signal. The settings of this register are reflected both in external address space read mode and manual mode.

The settings of this register should be changed when the TEND flag in CMNSR is 1; otherwise, the operation cannot be guaranteed.

Bit	31	30	29	28	27	26	25	24	23	22	21	20	19	18	17	16
	—	—	—	—	—	—	—	—	—	—	—	—	—	SPNDL[2:0]		
Initial Value	0	0	0	0	0	0	0	0	0	0	0	0	0	0	0	0
R/W	R	R	R	R	R	R	R	R	R	R	R	R	R	R/W	R/W	R/W
Bit	15	14	13	12	11	10	9	8	7	6	5	4	3	2	1	0
	—	—	—	—	—	SLNDL[2:0]			—	—	—	—	—	SCKDL[2:0]		
Initial Value	0	0	0	0	0	0	0	0	0	0	0	0	0	0	0	0
R/W	R	R	R	R	R	R/W	R/W	R/W	R	R	R	R	R	R/W	R/W	R/W

Bit	Bit Name	Initial Value	R/W	Description
31 to 19	—	All 0	R	Reserved These bits are always read as 0. The write value should always be 0.
18 to 16	SPNDL[2:0]	000	R/W	Next Access Delay Sets the period from transfer end to next transfer start (next access). 000: 1 QSPIn_SPCLK (3 QSPIn_SPCLK when SSLE = 0) 001: 2 QSPIn_SPCLK 010: 3 QSPIn_SPCLK 011: 4 QSPIn_SPCLK 100: 5 QSPIn_SPCLK 101: 6 QSPIn_SPCLK 110: 7 QSPIn_SPCLK 111: 8 QSPIn_SPCLK
15 to 11	—	All 0	R	Reserved These bits are always read as 0. The write value should always be 0.
10 to 8	SLNDL[2:0]	000	R/W	QSPIn_SSL Negation Delay Sets the period from the time the last QSPIn_SPCLK edge is sent of a transfer to QSPIn_SSL pin negation (QSPIn_SSL negation delay). 000: 1 QSPIn_SPCLK 001: 2 QSPIn_SPCLK 010: 3 QSPIn_SPCLK 011: 4 QSPIn_SPCLK 100: 5 QSPIn_SPCLK 101: 6 QSPIn_SPCLK 110: 7 QSPIn_SPCLK 111: 8 QSPIn_SPCLK
7 to 3	—	All 0	R	Reserved These bits are always read as 0. The write value should always be 0.

Bit	Bit Name	Initial Value	R/W	Description
2 to 0	SCKDL[2:0]	000	R/W	Clock Delay Sets the period from QSPIn_SSL pin assertion to QSPIn_SPCLK oscillation (clock delay). 000: 1.5 QSPIn_SPCLK 001: 2.5 QSPIn_SPCLK 010: 3.5 QSPIn_SPCLK 011: 4.5 QSPIn_SPCLK 100: 5.5 QSPIn_SPCLK 101: 6.5 QSPIn_SPCLK 110: 7.5 QSPIn_SPCLK 111: 8.5 QSPIn_SPCLK

25.4.3 Data Read Control Register (DRCR)

DRCR is a 32-bit register that sets the operation in external address space read mode.

The bits except the SSLN bit should be changed when the TEND flag in CMNSR is 1; otherwise, the operation cannot be guaranteed.

Bit	31	30	29	28	27	26	25	24	23	22	21	20	19	18	17	16
	—	—	—	—	—	—	—	SSLN	—	—	—	RBURST[4:0]				
Initial Value	0	0	0	0	0	0	0	0	0	0	0	1	1	1	1	1
R/W	R	R	R	R	R	R	R	W	R	R	R	R/W	R/W	R/W	R/W	R/W
Bit	15	14	13	12	11	10	9	8	7	6	5	4	3	2	1	0
	—	—	—	—	—	—	RCF	RBE	—	—	—	—	—	—	—	SSLE
Initial Value	0	0	0	0	0	0	0	1	0	0	0	0	0	0	0	0
R/W	R	R	R	R	R	R	W	R/W	R	R	R	R	R	R	R	R/W

Bit	Bit Name	Initial Value	R/W	Description
31 to 25	—	All 0	R	Reserved These bits are always read as 0. The write value should always be 0.
24	SSLN	0	W	QSPIn_SSL Negation Asserted QSPIn_SSL can be negated by writing 1 to this bit when both the RBE and SSLE bits are 1. This bit is always read as 0. <i>Note:</i> To start next access after QSPIn_SSL negation using this bit, read SSLF in CMNSR = 0 to confirm that the QSPIn_SSL has been negated.
23 to 21	—	All 0	R	Reserved These bits are always read as 0. The write value should always be 0.
20 to 16	RBURST[4:0]	11111	R/W	Read Data Burst Length Sets the burst length (data unit count) when reading. This bit field is enabled when the RBE bit is set to 1. 00000: 1 data unit 00001: 2 continuous data units : 11110: 31 continuous data units 11111: 32 continuous data units One data unit is 64 bits long.
15 to 10	—	All 0	R	Reserved These bits are always read as 0. The write value should always be 0.
9	RCF	0	W	Read Cache Flush When 1 is written to this bit, all the entries in the read cache are cleared. This bit is always read as 0. After using the cache area as the write buffer, the cache area must be cleared by writing 1 to the RCF bit. <i>Note:</i> After flushing the read cache by writing 1 to the RCF bit, read the DRCR register before proceeding to read from the external address space.

Bit	Bit Name	Initial Value	R/W	Description
8	RBE	1	R/W	<p>Read Burst</p> <p>Turns burst ON or OFF when reading.</p> <p>0: Data is read according to the access size.</p> <p>1: Read cache is enabled, and as many data units as the burst count specified in RBURST[4:0] bits is read.</p> <p><i>Note:</i> When the cache is enabled and read access reaches the last address of the flash memory, the access address does not match the address held in the cache. Control the read address and access size so that read access does not reach the last address of the flash memory.</p>
7 to 1	—	All 0	R	<p>Reserved</p> <p>These bits are always read as 0. The write value should always be 0.</p>
0	SSLE	0	R/W	<p>QSPIn_SSL Negation</p> <p>Sets the conditions for QSPIn_SSL negation during read burst.</p> <p>QSPIn_SSL is negated for each access during normal read.</p> <p>0: QSPIn_SSL is negated after transfer of data set in burst length.</p> <p>1: QSPIn_SSL is negated when the accessed address is not continuous with the previously transferred address.</p> <p><i>Note 1.</i> Set up this bit when a serial flash memory device is connected.</p> <p><i>Note 2.</i> When this bit is set to 1, setting the RBURST[4:0] bits to H'01 is prohibited.</p>

25.4.4 Data Read Command Setting Register (DRCMR)

DRCMR is a 32-bit register that sets the commands issued in external address space read mode.

The settings of this register should be changed when the TEND flag in CMNSR is 1; otherwise, the operation cannot be guaranteed.

Bit	31	30	29	28	27	26	25	24	23	22	21	20	19	18	17	16
	—	—	—	—	—	—	—	—	CMD[7:0]							
Initial Value	0	0	0	0	0	0	0	0	1	0	1	0	0	0	0	0
R/W	R	R	R	R	R	R	R	R	R/W	R/W	R/W	R/W	R/W	R/W	R/W	R/W
Bit	15	14	13	12	11	10	9	8	7	6	5	4	3	2	1	0
	—	—	—	—	—	—	—	—	OCMD[7:0]							
Initial Value	0	0	0	0	0	0	0	0	0	0	0	0	0	0	0	0
R/W	R	R	R	R	R	R	R	R	R/W	R/W	R/W	R/W	R/W	R/W	R/W	R/W

Bit	Bit Name	Initial Value	R/W	Description
31 to 24	—	All 0	R	Reserved These bits are always read as 0. The write value should always be 0.
23 to 16	CMD[7:0]	H'A0	R/W	Command Sets the command.
15 to 8	—	All 0	R	Reserved These bits are always read as 0. The write value should always be 0.
7 to 0	OCMD[7:0]	H'00	R/W	Optional Command Sets the optional command.

25.4.5 Data Read Extended Address Setting Register (DREAR)

DREAR is a 32-bit register that sets the address when the serial flash address is output in 32-bit mode.

The settings of this register should be changed when the TEND flag in CMNSR is 1; otherwise, the operation cannot be guaranteed.

Bit	31	30	29	28	27	26	25	24	23	22	21	20	19	18	17	16
	—								EAV[7:0]							
Initial Value	0	0	0	0	0	0	0	0	0	0	0	0	0	0	0	0
R/W	R	R	R	R	R	R	R	R	R/W	R/W	R/W	R/W	R/W	R/W	R/W	R/W
Bit	15	14	13	12	11	10	9	8	7	6	5	4	3	2	1	0
	—													EAC[2:0]		
Initial Value	0	0	0	0	0	0	0	0	0	0	0	0	0	0	0	0
R/W	R	R	R	R	R	R	R	R	R	R	R	R	R	R	R/W	R/W

Bit	Bit Name	Initial Value	R/W	Description
31 to 24	—	All 0	R	Reserved These bits are always read as 0. The write value should always be 0.
23 to 16	EAV[7:0]	H'00	R/W	32-Bit Extended Upper Address Fixed Value Sets the upper address bit values of the external address specified by the EAC[2:0] bits when the serial flash address is output in 32-bit mode. Bit 0 corresponds to the serial flash address bit [25], and bit 7 corresponds to the bit [32]. This setting is valid when the ADE[3] bit in DRENr is 1. When EAC[2:0] are 000, serial flash address [32:25] fixed values should set to EAV[7:0]. When EAC[2:0] are 001, serial flash address [32:26] fixed values should set to EAV[7:1]. When EAC[2:0] are 010, serial flash address [32:27] fixed values should set to EAV[7:2]. When EAC[2:0] are 011, serial flash address [32:28] fixed values should set to EAV[7:3]. When BSZ[1:0] in CMNCR = 00 (one serial flash memory connected) Serial flash addresses [31:0] are used for accessing.
15 to 3	—	All 0	R	Reserved These bits are always read as 0. The write value should always be 0.
2 to 0	EAC[2:0]	000	R/W	32-Bit Extended External Address Valid Range Sets the range of the external address to be used as serial flash address when the serial flash address is output in 32-bit mode. This setting is valid when the ADE[3] bit in DRENr is 1. 000: External address bits [24:0] enabled 001: External address bits [25:0] enabled 010: External address bits [26:0] enabled 011: External address bits [27:0] enabled Other than above: Setting prohibited

25.4.6 Data Read Option Setting Register (DROPR)

DROPR is a 32-bit register that sets the option data in external address space read mode.

The settings of this register should be changed when the TEND flag in CMNSR is 1; otherwise, the operation cannot be guaranteed.

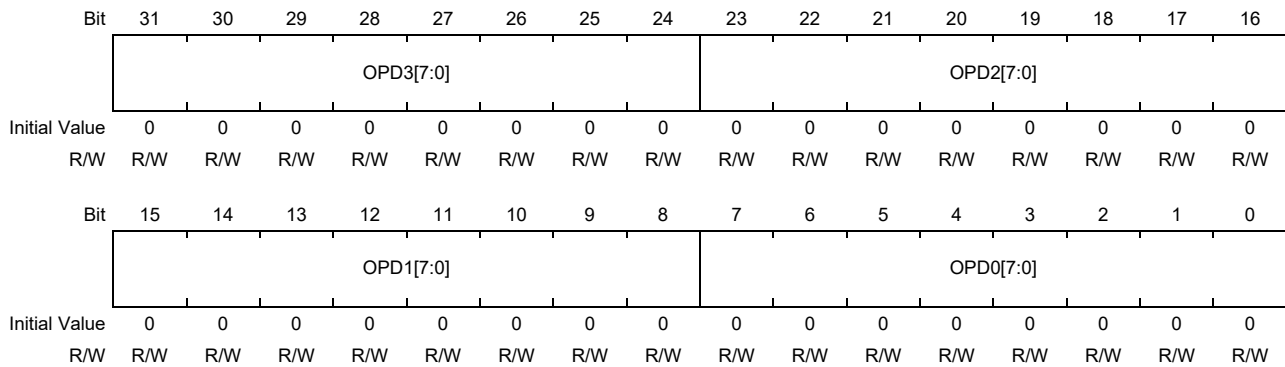

Bit	Bit Name	Initial Value	R/W	Description
31 to 24	OPD3[7:0]	H'00	R/W	Option Data 3 Sets the option data 3.
23 to 16	OPD2[7:0]	H'00	R/W	Option Data 2 Sets the option data 2.
15 to 8	OPD1[7:0]	H'00	R/W	Option Data 1 Sets the option data 1.
7 to 0	OPD0[7:0]	H'00	R/W	Option Data 0 Sets the option data 0.

Note: OPD3, OPD2, OPD1, and OPD0 are output in this order.

25.4.7 Data Read Enable Setting Register (DRENr)

DRENr is a 32-bit register that sets the bit size of the command, optional command, address, option data, and read data in external address space read mode and enables outputting them other than read data.

The settings of this register should be changed when the TEND flag in CMNSR is 1; otherwise, the operation cannot be guaranteed.

Bit	31	30	29	28	27	26	25	24	23	22	21	20	19	18	17	16
	CDB[1:0]		OCDB[1:0]		—	—	ADB[1:0]		—	—	OPDB[1:0]		—	—	DRDB[1:0]	
Initial Value	1	0	1	0	0	0	1	0	0	0	1	0	0	0	1	0
R/W	R/W	R/W	R/W	R/W	R	R	R/W	R/W	R	R	R/W	R/W	R	R	R/W	R/W
Bit	15	14	13	12	11	10	9	8	7	6	5	4	3	2	1	0
	DME	CDE	—	OCDE	ADE[3:0]				OPDE[3:0]				—	—	—	—
Initial Value	1	1	0	1	0	1	0	0	0	0	0	0	0	0	0	0
R/W	R/W	R/W	R	R/W	R/W	R/W	R/W	R/W	R/W	R/W	R/W	R/W	R	R	R	R

Bit	Bit Name	Initial Value	R/W	Description
31, 30	CDB[1:0]	10	R/W	Command Bit Size Sets the command size in bit units. 00: 1 bit 10: 4 bits Other than above: Setting prohibited
29, 28	OCDB[1:0]	10	R/W	Optional Command Bit Size Sets the optional command size in bit units. 00: 1 bit 10: 4 bits Other than above: Setting prohibited
27, 26	—	All 0	R	Reserved These bits are always read as 0. The write value should always be 0.
25, 24	ADB[1:0]	10	R/W	Address Bit Size Sets the address size in bit units. 00: 1 bit 10: 4 bits Other than above: Setting prohibited
23, 22	—	All 0	R	Reserved These bits are always read as 0. The write value should always be 0.
21, 20	OPDB[1:0]	10	R/W	Option Data Bit Size Sets the option data size in bit units. 00: 1 bit 10: 4 bits Other than above: Setting prohibited
19, 18	—	All 0	R	Reserved These bits are always read as 0. The write value should always be 0.
17, 16	DRDB[1:0]	10	R/W	Data Read Bit Size Sets the data read size in bit units. 00: 1 bit 10: 4 bits Other than above: Setting prohibited

Bit	Bit Name	Initial Value	R/W	Description
15	DME	1	R/W	<p>Dummy Cycle Enable Enables insertion of the dummy cycle before the read data.</p> <p><i>Note:</i> A setting is prohibited for a transfer starting with a dummy cycle. 0: Dummy cycle insertion disabled 1: Dummy cycle insertion enabled</p>
14	CDE	1	R/W	<p>Command Enable Sets whether or not the command is to be output. 0: Command output disabled 1: Command output enabled</p>
13	—	0	R	<p>Reserved This bit is always read as 0. The write value should always be 0.</p>
12	OCDE	1	R/W	<p>Optional Command Enable Sets whether or not the optional command is to be output. 0: Optional command output disabled 1: Optional command output enabled</p>
11 to 8	ADE[3:0]	0100	R/W	<p>Address Enable Sets the address to be output. Be sure to use the following setting; otherwise, the operation is not guaranteed. When a serial flash memory device is connected 0000: Output disabled 0111: Address[23:0] 1111: Address[31:0] Other than above: Setting prohibited</p>
7 to 4	OPDE[3:0]	0000	R/W	<p>Option Data Enable Sets the option data to be output. Use only the settings given below. Otherwise, the operation cannot be guaranteed. 0000: Output disabled 1000: OPD3 1100: OPD3, OPD2 1110: OPD3, OPD2, OPD1 1111: OPD3, OPD2, OPD1, OPD0 Other than above: Setting prohibited</p>
3 to 0	—	All 0	R	<p>Reserved These bits are always read as 0. The write value should always be 0.</p>

25.4.8 Manual Mode Control Register (SMCR)

SMCR is a 32-bit register that sets the operation in Manual mode.

The settings of this register should be changed when the TEND flag in CMNSR is 1; otherwise, the operation cannot be guaranteed.

Bit	31	30	29	28	27	26	25	24	23	22	21	20	19	18	17	16
	—	—	—	—	—	—	—	—	—	—	—	—	—	—	—	—
Initial Value	0	0	0	0	0	0	0	0	0	0	0	0	0	0	0	0
R/W	R	R	R	R	R	R	R	R	R	R	R	R	R	R	R	R
Bit	15	14	13	12	11	10	9	8	7	6	5	4	3	2	1	0
	—	—	—	—	—	—	—	SSLKP	—	—	—	—	—	SPIRE	SPIWE	SPIE
Initial Value	0	0	0	0	0	0	0	0	0	0	0	0	0	0	0	0
R/W	R	R	R	R	R	R	R	R/W	R	R	R	R	R	R/W	R/W	W

Bit	Bit Name	Initial Value	R/W	Description
31 to 9	—	All 0	R	Reserved These bits are always read as 0. The write value should always be 0.
8	SSLKP	0	R/W	QSPIn_SSL Signal Level Determines the QSPIn_SSL status after the end of transfer. 0: QSPIn_SSL signal is negated at the end of transfer. 1: QSPIn_SSL signal level is maintained from the end of transfer to the start of next access. <i>Note:</i> The setting to start data transfer for reading is prohibited while the setting of SSLKP is 1.
7 to 3	—	All 0	R	Reserved These bits are always read as 0. The write value should always be 0.
2	SPIRE	0	R/W	Data Read Enable Enables reading in manual mode. 0: Data reading disabled 1: Data reading enabled <i>Note:</i> When the transfer data bit size is set to 4 bits with the SPIDB[1:0] bits, the SPIRE and SPIWE bits should not be set to 1 at the same time.
1	SPIWE	0	R/W	Data Write Enable Enables writing in manual mode. 0: Data writing disabled 1: Data writing enabled <i>Note:</i> When the transfer data bit size is set to 4 bits with the SPIDB[1:0] bits, the SPIRE and SPIWE bits should not be set to 1 at the same time.
0	SPIE	0	W	SPI Data Transfer Enable Data is transferred by setting this bit to 1. This bit is enabled only when the TEND bit in CMNSR is set to 1. The operation cannot be guaranteed when this bit is set to 1 with the TEND bit set to 0. This bit is always read as 0. <i>Note:</i> When the QSPIn_SSL pin is de-asserted, the command, optional command, address, and option data that are output enabled are output even if the SPIRE and SPIWE bits are set to 0. When the QSPIn_SSL pin is asserted, follow the notes described in Section 25.6.3, Notes on Starting Transfer from the QSPIn_SSL Retained State in Manual Mode.

25.4.9 Manual Mode Command Setting Register (SMCMR)

SMCMR is a 32-bit register that sets the commands issued in Manual mode.

The settings of this register should be changed when the TEND flag in CMNSR is 1; otherwise, the operation cannot be guaranteed.

Bit	31	30	29	28	27	26	25	24	23	22	21	20	19	18	17	16	
	—	—	—	—	—	—	—	—	CMD[7:0]								
Initial Value	0	0	0	0	0	0	0	0	0	0	0	0	0	0	0	0	0
R/W	R	R	R	R	R	R	R	R	R/W	R/W	R/W	R/W	R/W	R/W	R/W	R/W	R/W
Bit	15	14	13	12	11	10	9	8	7	6	5	4	3	2	1	0	
	—	—	—	—	—	—	—	—	OCMD[7:0]								
Initial Value	0	0	0	0	0	0	0	0	0	0	0	0	0	0	0	0	
R/W	R	R	R	R	R	R	R	R	R/W	R/W	R/W	R/W	R/W	R/W	R/W	R/W	

Bit	Bit Name	Initial Value	R/W	Description
31 to 24	—	All 0	R	Reserved These bits are always read as 0. The write value should always be 0.
23 to 16	CMD[7:0]	H'00	R/W	Command Sets the command.
15 to 8	—	All 0	R	Reserved These bits are always read as 0. The write value should always be 0.
7 to 0	OCMD[7:0]	H'00	R/W	Optional Command Sets the optional command.

25.4.10 Manual Mode Address Setting Register (SMADR)

SMADR is a 32-bit register that sets the addresses in Manual mode.

The settings of this register should be changed when the TEND flag in CMNSR is 1; otherwise, the operation cannot be guaranteed.

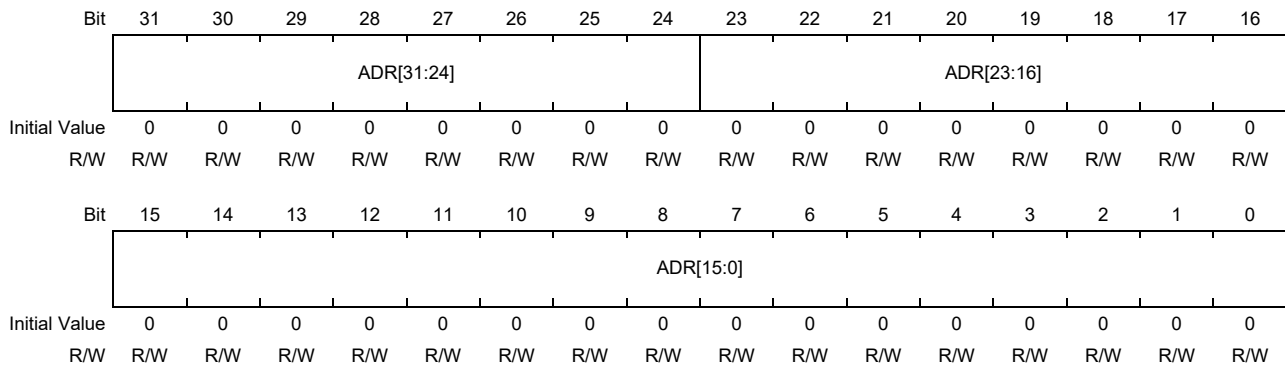

Bit	Bit Name	Initial Value	R/W	Description
31 to 24	ADR[31:24]	H'00	R/W	Address Sets the value of bits 31 to 24 when the serial flash address is output in 32-bit units. This setting is valid when ADE[3] in SMENR is 1.
23 to 0	ADR[23:0]	H'000000	R/W	Address Sets the address.

25.4.11 Manual Mode Option Setting Register (SMOPR)

SMOPR is a 32-bit register that sets the option data in Manual mode.

The settings of this register should be changed when the TEND flag in CMNSR is 1; otherwise, the operation cannot be guaranteed.

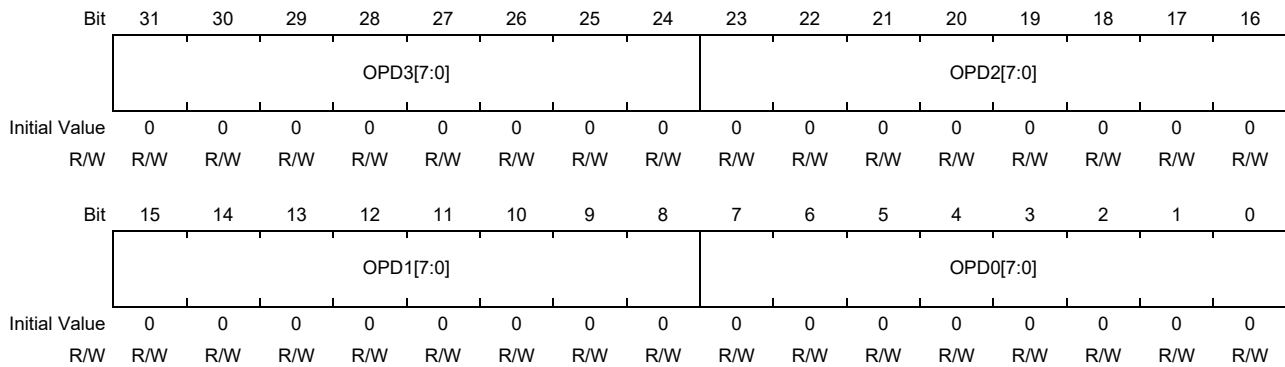

Bit	Bit Name	Initial Value	R/W	Description
31 to 24	OPD3[7:0]	H'00	R/W	Option Data 3 Sets the option data 3.
23 to 16	OPD2[7:0]	H'00	R/W	Option Data 2 Sets the option data 2.
15 to 8	OPD1[7:0]	H'00	R/W	Option Data 1 Sets the option data 1.
7 to 0	OPD0[7:0]	H'00	R/W	Option Data 0 Sets the option data 0.

Note: OPD3, OPD2, OPD1, and OPD0 are output in this order.

25.4.12 Manual Mode Enable Setting Register (SMENR)

SMENR is a 32-bit register that sets the bit size of the command, optional command, address, option data, and transfer data in Manual mode and enables their output. SMENR also enables dummy cycle insertion. Disabling all of the command, optional command, address, option data, dummy cycle, and transfer data is prohibited. At least one of them except dummy cycle must be enabled.

The settings of this register should be changed when the TEND flag in CMNSR is 1; otherwise, the operation cannot be guaranteed.

Bit	31	30	29	28	27	26	25	24	23	22	21	20	19	18	17	16
	CDB[1:0]		OCDB[1:0]		—	—	ADB[1:0]		—	—	OPDB[1:0]		—	—	SPIDB[1:0]	
Initial Value	0	0	0	0	0	0	0	0	0	0	0	0	0	0	0	0
R/W	R/W	R/W	R/W	R/W	R	R	R/W	R/W	R	R	R/W	R/W	R	R	R/W	R/W
Bit	15	14	13	12	11	10	9	8	7	6	5	4	3	2	1	0
	DME	CDE	—	OCDE	ADE[3:0]				OPDE[3:0]				SPIDE[3:0]			
Initial Value	0	1	0	0	0	0	0	0	0	0	0	0	0	0	0	0
R/W	R/W	R/W	R	R/W	R/W	R/W	R/W	R/W	R/W	R/W	R/W	R/W	R/W	R/W	R/W	R/W

Bit	Bit Name	Initial Value	R/W	Description
31, 30	CDB[1:0]	00	R/W	Command Bit Size Sets the command size in bit units. 00: 1 bit 10: 4 bits Other than above: Setting prohibited
29, 28	OCDB[1:0]	00	R/W	Optional Command Bit Size Sets the optional command size in bit units. 00: 1 bit 10: 4 bits Other than above: Setting prohibited
27, 26	—	All 0	R	Reserved These bits are always read as 0. The write value should always be 0.
25, 24	ADB[1:0]	00	R/W	Address Bit Size Sets the address size in bit units. 00: 1 bit 10: 4 bits Other than above: Setting prohibited
23, 22	—	All 0	R	Reserved These bits are always read as 0. The write value should always be 0.
21, 20	OPDB[1:0]	00	R/W	Option Data Bit Size Sets the option data size in bit units. 00: 1 bit 10: 4 bits Other than above: Setting prohibited
19, 18	—	All 0	R	Reserved These bits are always read as 0. The write value should always be 0.
17, 16	SPIDB[1:0]	00	R/W	Transfer Data Bit Size Sets the transfer data size in bit units. 00: 1 bit 10: 4 bits Other than above: Setting prohibited

Bit	Bit Name	Initial Value	R/W	Description
15	DME	0	R/W	<p>Dummy Cycle Enable Enables insertion of the dummy cycle before the read data.</p> <p><i>Note:</i> Dummy cycle insertion is prohibited for write in Manual mode including the case in which a transfer ends with a dummy cycle.</p> <p><i>Note:</i> A setting is prohibited for a transfer starting with a dummy cycle. 0: Dummy cycle insertion disabled 1: Dummy cycle insertion enabled</p>
14	CDE	1	R/W	<p>Command Enable Sets the command to be output. 0: Command output disabled 1: Command output enabled</p>
13	—	0	R	<p>Reserved This bit is always read as 0. The write value should always be 0.</p>
12	OCDE	0	R/W	<p>Optional Command Enable Sets the optional command to be output. 0: Optional command output disabled 1: Optional command output enabled</p>
11 to 8	ADE[3:0]	0000	R/W	<p>Address Enable Sets the address to be output. Use only the settings given below. Otherwise, the operation cannot be guaranteed. When a serial flash memory device is connected 0000: Output disabled 0100: ADR[23:16] 0110: ADR[23:8] 0111: ADR[23:0] 1111: ADR[31:0] Other than above: Setting prohibited</p> <p><i>Note:</i> The setting of these bits is required to be 0111 or 1111 when the write buffer is in use.</p>
7 to 4	OPDE[3:0]	0000	R/W	<p>Option Data Enable Sets the option data to be output. Use only the settings given below. Otherwise, the operation cannot be guaranteed. 0000: Output disabled 1000: OPD3 1100: OPD3, OPD2 1110: OPD3, OPD2, OPD1 1111: OPD3, OPD2, OPD1, OPD0 Other than above: Setting prohibited</p>
3 to 0	SPIDE[3:0]	0000	R/W	<p>Transfer Data Enable Sets valid transfer data. The following settings must be used. Otherwise, the operation is not guaranteed. BSZ[1:0] bits in CMNCR = 00 (one serial flash memory connected) 0000: Not transferred 1000: 8 bits transferred (enables data at address 0 of the Manual mode read/write data registers 0) 1100: 16 bits transferred (enables data at addresses 0 and 1 of the Manual mode read/write data registers 0) 1111: 32 bits transferred (enables data at addresses 0 to 3 of the Manual mode read/write data registers 0) Other than above: Setting prohibited</p>

25.4.13 Manual Mode Read Data Register 0 (SMRDR0)

SMRDR0 is a 32-bit register that stores the read data in Manual mode.

Access to this register should be performed in the same size as the transfer size specified in the SPIDE[3:0] bits in the Manual mode enable setting register (SMENR). Be sure to access from LSB.

The settings of this register should be read when the TEND flag in CMNSR is 1; otherwise, the operation cannot be guaranteed.

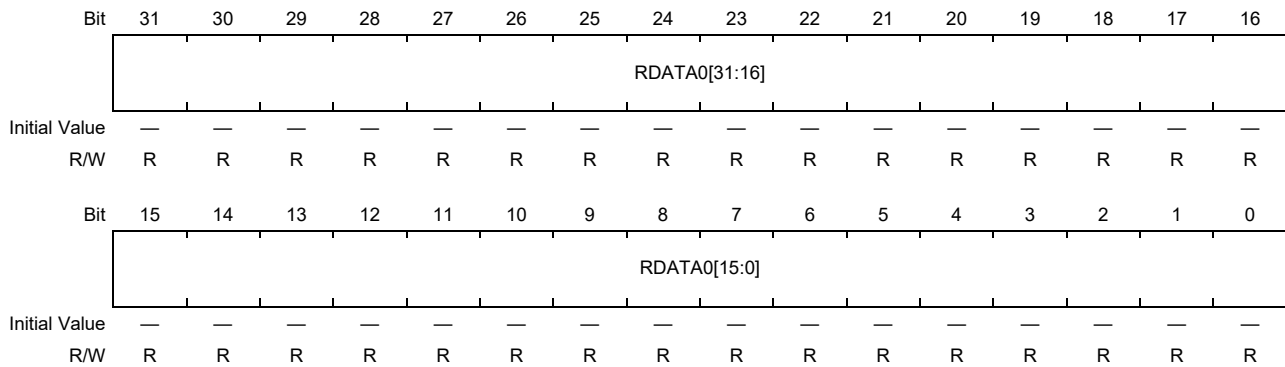

Bit	Bit Name	Initial Value	R/W	Description
31 to 0	RDATA0[31:0]	Undefined	R	Read Data Holds the data read in Manual mode. Data bits differ depending on the BSZ[1:0] bit setting in CMNCR.

Note: The contents of this register is modified upon completion of reception in manual mode. Be sure to read data when reception in manual mode is completed.

25.4.14 Manual Mode Write Data Register 0 (SMWDR0)

SMWDR0 is a 32-bit register that sets the write data in Manual mode.

Access to this register should be performed in the same size as the transfer size specified in the SPIDE[3:0] bits in the Manual mode enable setting register (SMENR). Be sure to access from address 0.

The settings of this register should be changed when the TEND flag in CMNSR is 1; otherwise, the operation cannot be guaranteed.

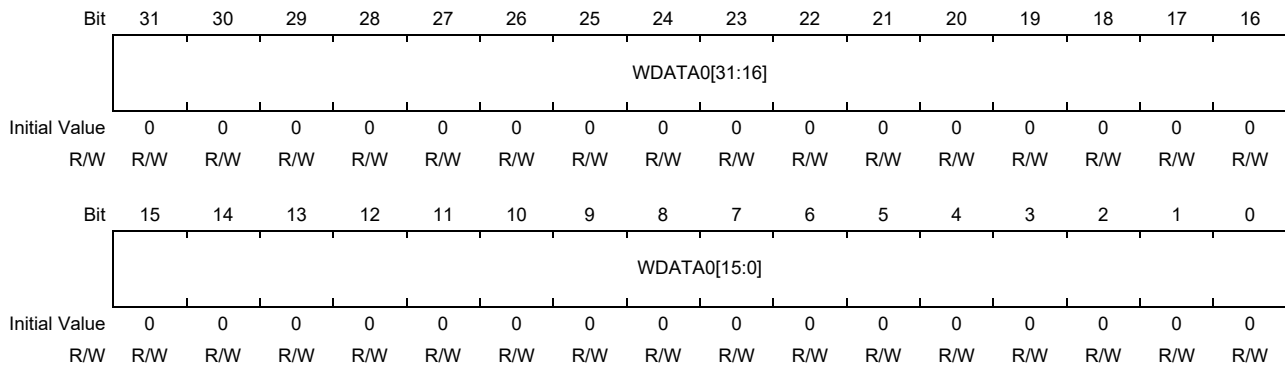

Bit	Bit Name	Initial Value	R/W	Description
31 to 0	WDATA0 [31:0]	All 0	R/W	Write Data Holds the data to be written in Manual mode. Data bits differ depending on the BSZ[1:0] bit setting in CMNCR.

25.4.15 Common Status Register (CMNSR)

CMNSR is a 32-bit register that holds flags indicating the operating state.

The settings of this register are reflected both in external address space read mode and Manual mode.

Bit	31	30	29	28	27	26	25	24	23	22	21	20	19	18	17	16
	—	—	—	—	—	—	—	—	—	—	—	—	—	—	—	—
Initial Value	0	0	0	0	0	0	0	0	0	0	0	0	0	0	0	0
R/W	R	R	R	R	R	R	R	R	R	R	R	R	R	R	R	R
Bit	15	14	13	12	11	10	9	8	7	6	5	4	3	2	1	0
	—	—	—	—	—	—	—	—	—	—	—	—	—	—	SSLF	TEND
Initial Value	0	0	0	0	0	0	0	0	0	0	0	0	0	0	0	1
R/W	R	R	R	R	R	R	R	R	R	R	R	R	R	R	R	R

Bit	Bit Name	Initial Value	R/W	Description
31 to 2	—	All 0	R	Reserved These bits are always read as 0. The write value should always be 0.
1	SSLF	0	R	QSPIn_SSL Pin Monitor 0: QSPIn_SSL pin is negated 1: QSPIn_SSL pin is asserted
0	TEND	1	R	Transfer End Flag Indicates whether the data transfer has ended. 0: Indicates that data transfer is in progress 1: Indicates that data transfer has ended

25.4.16 Data Read Dummy Cycle Setting Register (DRDMCR)

DRDMCR is a 32-bit register that sets the number of dummy cycles to be inserted in external address space read mode. The settings of this register are enabled when the DME bit in the data read enable setting register (DRENr) is 1.

The settings of this register should be changed when the TEND flag in CMNSR is 1; otherwise, the operation cannot be guaranteed.

Bit	31	30	29	28	27	26	25	24	23	22	21	20	19	18	17	16
	—	—	—	—	—	—	—	—	—	—	—	—	—	—	—	—
Initial Value	0	0	0	0	0	0	0	0	0	0	0	0	0	0	0	0
R/W	R	R	R	R	R	R	R	R	R	R	R	R	R	R	R	R
Bit	15	14	13	12	11	10	9	8	7	6	5	4	3	2	1	0
	—	—	—	—	—	—	—	—	—	—	—	DMCYC[4:0]				
Initial Value	0	0	0	0	0	0	0	0	0	0	0	0	1	0	1	1
R/W	R	R	R	R	R	R	R	R	R	R	R	R/W	R/W	R/W	R/W	R/W

Bit	Bit Name	Initial Value	R/W	Description
31 to 5	—	All 0	R	Reserved These bits are always read as 0. The write value should always be 0.
4 to 0	DMCYC[4:0]	H'0B	R/W	Number of Dummy Cycles Sets the number of dummy cycles to be inserted when the DME bit in the data read enable setting register (DRENr) is 1. 00001: 2 cycles 00010: 3 cycles ... 10010: 19 cycles 10011: 20 cycles Other than above: Setting prohibited

25.4.17 Data Read DDR Enable Register (DRDRENr)

DRDRENr is a 32-bit register that sets SDR or DDR transfer of the address, option data, and read data in external address space read mode.

The settings of this register should be changed when the TEND flag in CMNSR is 1; otherwise, the operation cannot be guaranteed.

Bit	31	30	29	28	27	26	25	24	23	22	21	20	19	18	17	16
	—	—	—	—	—	—	—	—	—	—	—	—	—	—	—	—
Initial Value	0	0	0	0	0	0	0	0	0	0	0	0	0	0	0	0
R/W	R	R	R	R	R	R	R	R	R	R	R	R	R	R	R	R
Bit	15	14	13	12	11	10	9	8	7	6	5	4	3	2	1	0
	—	HYPE		—	—	—	ADDRE	—	—	—	OPDRE	—	—	—	—	DRDRE
Initial Value	0	1	0	1	0	0	0	1	0	0	0	0	0	0	0	1
R/W	R	R/W	R/W	R/W	R	R	R	R/W	R	R	R	R/W	R	R	R	R/W

Bit	Bit Name	Initial Value	R/W	Description
31 to 15	—	All 0	R	Reserved These bits are always read as 0. The write value should always be 0.
14 to 12	HYPE	101	R/W	HyperFlash, Octal-SPI flash memory DDR mode enable 000: SPI flash mode Other than above: Setting prohibited <i>Note:</i> Be sure to change the HYPE bits from the initial value to "000"
11 to 9	—	All 0	R	Reserved These bits are always read as 0. The write value should always be 0.
8	ADDRE	1	R/W	Address DDR Enable Sets SDR or DDR transfer of the address. 0: SDR transfer 1: DDR transfer
7 to 5	—	All 0	R	Reserved These bits are always read as 0. The write value should always be 0.
4	OPDRE	0	R/W	Option Data DDR Enable Sets SDR or DDR transfer of the option data. 0: SDR transfer 1: DDR transfer
3 to 1	—	All 0	R	Reserved These bits are always read as 0. The write value should always be 0.
0	DRDRE	1	R/W	Data Read DDR Enable Sets SDR or DDR transfer of the read data. 0: SDR transfer 1: DDR transfer

25.4.18 Manual Mode Dummy Cycle Setting Register (SMDMCR)

SMDMCR is a 32-bit register that sets the number of dummy cycles to be inserted in Manual mode.

The settings of this register are enabled when the DME bit in the Manual mode enable setting register (SMENR) is 1.

The settings of this register should be changed when the TEND flag in CMNSR is 1; otherwise, the operation cannot be guaranteed.

Bit	31	30	29	28	27	26	25	24	23	22	21	20	19	18	17	16
	—	—	—	—	—	—	—	—	—	—	—	—	—	—	—	—
Initial Value	0	0	0	0	0	0	0	0	0	0	0	0	0	0	0	0
R/W	R	R	R	R	R	R	R	R	R	R	R	R	R	R	R	R
Bit	15	14	13	12	11	10	9	8	7	6	5	4	3	2	1	0
	—	—	—	—	—	—	—	—	—	—	—	DMCYC[4:0]				
Initial Value	0	0	0	0	0	0	0	0	0	0	0	0	0	0	0	0
R/W	R	R	R	R	R	R	R	R	R	R	R	R/W	R/W	R/W	R/W	R/W

Bit	Bit Name	Initial Value	R/W	Description
31 to 5	—	All 0	R	Reserved These bits are always read as 0. The write value should always be 0.
4 to 0	DMCYC[4:0]	00000	R/W	Number of Dummy Cycles Sets the number of dummy cycles to be inserted when the DME bit in the Manual mode enable setting register (SMENR) is 1. 00001: 2 cycles 00010: 3 cycles 10010: 19 cycles 10011: 20 cycles Other than above: Setting prohibited

25.4.19 Manual Mode DDR Enable Register (SMDRENR)

SMDRENR is a 32-bit register that sets SDR or DDR transfer of the address, option data, and transfer data in Manual mode.

The settings of this register should be changed when the TEND flag in CMNSR is 1; otherwise, the operation cannot be guaranteed.

Bit	31	30	29	28	27	26	25	24	23	22	21	20	19	18	17	16
	—	—	—	—	—	—	—	—	—	—	—	—	—	—	—	—
Initial Value	0	0	0	0	0	0	0	0	0	0	0	0	0	0	0	0
R/W	R	R	R	R	R	R	R	R	R	R	R	R	R	R	R	R
Bit	15	14	13	12	11	10	9	8	7	6	5	4	3	2	1	0
	—	—	—	—	—	—	—	ADDRE	—	—	—	OPDRE	—	—	—	SPIDRE
Initial Value	0	0	0	0	0	0	0	0	0	0	0	0	0	0	0	0
R/W	R	R	R	R	R	R	R	R/W	R	R	R	R/W	R	R	R	R/W

Bit	Bit Name	Initial Value	R/W	Description
31 to 15	—	All 0	R	Reserved These bits are always read as 0. The write value should always be 0.
14 to 12	—	000	R	Reserved When read, the initial value is read. When writing, be sure to write the initial value. Operation is not guaranteed if a value other than the initial value is written.
11 to 9	—	All 0	R	Reserved These bits are always read as 0. The write value should always be 0.
8	ADDRE	0	R/W	Address DDR Enable Sets SDR or DDR transfer of the address. 0: SDR transfer 1: DDR transfer
7 to 5	—	All 0	R	Reserved These bits are always read as 0. The write value should always be 0.
4	OPDRE	0	R/W	Option Data DDR Enable Sets SDR or DDR transfer of the option data. 0: SDR transfer 1: DDR transfer
3 to 1	—	All 0	R	Reserved These bits are always read as 0. The write value should always be 0.
0	SPIDRE	0	R/W	Transfer Data DDR Enable Sets SDR or DDR transfer of the transfer data. 0: SDR transfer 1: DDR transfer

25.4.20 PHY Control Register (PHYCNT)

PHYCNT is a 32-bit register that sets the PHY operation mode.

The settings of this register should be changed when the TEND flag in CMNSR is 1; otherwise, the operation cannot be guaranteed.

Bit	31	30	29	28	27	26	25	24	23	22	21	20	19	18	17	16
	CAL	—	—	—	—	—	—	—	—	—	—	—	—	HS	CKSEL[1:0]	
Initial Value	0	0	0	0	0	0	0	0	0	0	0	0	0	0	0	0
R/W	W	R	R	R	R	R	R	R	R	R	R	R	R	R/W	R/W	R/W
Bit	15	14	13	12	11	10	9	8	7	6	5	4	3	2	1	0
	—	—	—	—	—	—	—	—	—	—	—	WBUF2	—	WBUF	PHYMEM[1:0]	
Initial Value	0	0	0	0	0	0	1	0	0	1	1	0	0	0	1	1
R/W	R	R	R	R	R	R	R	R	R	R	R	R/W	R	R/W	R/W	R/W

Bit	Bit Name	Initial Value	R/W	Description
31	CAL	0	W	PHY Calibration Specifies whether to perform PHY calibration. Be sure to perform calibration before access in Manual mode. 0: Calibration is not performed. 1: Calibration is performed.
30	—	0	R	Reserved When read, the initial value is read. When writing, be sure to write the initial value. Operation is not guaranteed if a value other than the initial value is written.
29 to 24	—	All 0	R	Reserved These bits are always read as 0. The write value should always be 0.
23 to 20	—	All 0	R	Reserved When read, the initial value is read. When writing, be sure to write the initial value. Operation is not guaranteed if a value other than the initial value is written.
19	—	0	R	Reserved This bit is always read as 0. The write value should always be 0.
18	HS	0	R/W	High-Speed Response Mode Specifies the high-speed response mode. 0: Data is read for the number of data units specified in the RBURST bits of the DRCCR register and then output to the bus master. 1: The read data is output to bus master in parallel of device access when DRCCR.RBE = 1. <i>Note 1.</i> When this bit is set to 1, use DMA transfer. The transfer size in the RBURST[4:0] bits of the DRCCR register should be fixed to H'1F. <i>Note 2.</i> Do not access the register area during DMA transfer.
17, 16	CKSEL[1:0]	00	R/W	Clock Timing Switching Adjusts the timing of the clock when serial flash is connected. Always follow the procedure for setting shown in Section 25.5.14, Timing Adjustment.
15 to 10	—	All 0	R	Reserved These bits are always read as 0. The write value should always be 0.
9	—	1	R	Reserved This bit is always read as 1. The write value should always be 1.

Bit	Bit Name	Initial Value	R/W	Description
8, 7	—	All 0	R	Reserved These bits are always read as 0. The write value should always be 0.
6, 5	—	All 1	R	Reserved These bits are always read as 1. The write value should always be 1.
4	WBUF2	0	R/W	Write Buffer Enable 2 Specifies whether to use the write buffer to write data to the flash memory. For the usage of the write buffer, refer to Section 25.5.12, Write Buffer Operation . 0: The write buffer is not used. 1: The write buffer is used to write data to the flash memory.
3	—	0	R	Reserved This bit is always read as 0. The write value should always be 0.
2	WBUF	0	R/W	Write Buffer Enable Specifies whether to use the write buffer to write data to the flash memory. For the usage of the write buffer, refer to Section 25.5.12, Write Buffer Operation . 0: The write buffer is not used. 1: The write buffer is used to write data to the flash memory.
1, 0	PHYMEM[1:0]	11	R/W	Device Selection Selects the device to be connected. 00: Serial flash memory in SDR mode 01: Serial flash memory in DDR mode Other than above: Setting prohibited

25.4.21 PHY Offset Register 1 (PHYOFFSET1)

PHYOFFSET1 is a 32-bit register that sets the timing adjustment in the DDR operation.

The settings of this register should be changed when the TEND flag in CMNSR is 1; otherwise, the operation cannot be guaranteed.

Bit	31	30	29	28	27	26	25	24	23	22	21	20	19	18	17	16
	—	—	DDRTMG		—	—	—	—	—	—	—	—	—	—	—	—
Initial Value	0	0	1	0	0	0	0	1	0	1	0	1	0	0	0	1
R/W	R	R	R/W	R/W	R	R	R	R	R	R	R	R	R	R	R	R
Bit	15	14	13	12	11	10	9	8	7	6	5	4	3	2	1	0
	—	—	—	—	—	—	—	—	—	—	—	—	—	—	—	—
Initial Value	0	0	0	1	0	0	0	1	0	1	0	0	0	1	0	0
R/W	R	R	R	R	R	R	R	R	R	R	R	R	R	R	R	R

Bit	Bit Name	Initial Value	R/W	Description
31, 30	—	All 0	R	Reserved These bits are always read as 0. The write value should always be 0.
29, 28	DDRTMG	10	R/W	DDR Operation Timing Adjusts the timing of reading in the DDR mode. 10: Specify this value for reading when SMDREN.R.SPIDRE = 1 or DRDREN.R.DRDRE = 1. 11: Specify this value for reading when SMDREN.R.SPIDRE = 0 or DRDREN.R.DRDRE = 0. Other than above: Setting prohibited
27 to 25	—	All 0	R	Reserved These bits are always read as 0. The write value should always be 0.
24	—	1	R	Reserved This bit is always read as 1. The write value should always be 1.
23	—	0	R	Reserved This bit is always read as 0. The write value should always be 0.
22	—	1	R	Reserved This bit is always read as 1. The write value should always be 1.
21	—	0	R	Reserved This bit is always read as 0. The write value should always be 0.
20	—	1	R	Reserved This bit is always read as 1. The write value should always be 1.
19 to 17	—	All 0	R	Reserved These bits are always read as 0. The write value should always be 0.
16	—	1	R	Reserved This bit is always read as 1. The write value should always be 1.
15 to 13	—	All 0	R	Reserved These bits are always read as 0. The write value should always be 0.
12	—	1	R	Reserved This bit is always read as 1. The write value should always be 1.
11 to 9	—	All 0	R	Reserved These bits are always read as 0. The write value should always be 0.
8	—	1	R	Reserved This bit is always read as 1. The write value should always be 1.

Bit	Bit Name	Initial Value	R/W	Description
7	—	0	R	Reserved This bit is always read as 0. The write value should always be 0.
6	—	1	R	Reserved This bit is always read as 1. The write value should always be 1.
5 to 3	—	All 0	R	Reserved These bits are always read as 0. The write value should always be 0.
2	—	1	R	Reserved This bit is always read as 1. The write value should always be 1.
1, 0	—	All 0	R	Reserved These bits are always read as 0. The write value should always be 0.

25.4.22 PHY Offset Register 2 (PHYOFFSET2)

PHYOFFSET2 is a 32-bit register that sets the timing adjustment in the DDR operation.

The settings of this register should be changed when the TEND flag in CMNSR is 1; otherwise, the operation cannot be guaranteed.

Bit	31	30	29	28	27	26	25	24	23	22	21	20	19	18	17	16
	—	—	—	—	—	—	—	—	—	—	—	—	—	—	—	—
Initial Value	0	0	0	0	0	0	0	0	0	0	0	0	0	0	0	0
R/W	R	R	R	R	R	R	R	R	R	R	R	R	R	R	R	R
Bit	15	14	13	12	11	10	9	8	7	6	5	4	3	2	1	0
	—	—	—	—	—	OCTTMG		—	—	—	—	—	—	—	—	—
Initial Value	0	0	0	0	0	1	0	0	0	0	1	1	0	0	0	1
R/W	R	R	R	R	R	R/W	R/W	R/W	R	R	R	R	R	R	R	R

Bit	Bit Name	Initial Value	R/W	Description
31 to 11	—	All 0	R	Reserved These bits are always read as 0. The write value should always be 0.
10 to 8	OCTTMG	100	R/W	Serial flash memory Operation Timing Adjusts the timing of writing to the serial flash memory 000: Specify this value when using the serial flash memory with write buffer operation of the bit width 1-1-4 or 1-4-4 in Table 25.10 . 100: Specify this value when the serial flash memory is used. Other than above: Setting prohibited
7, 6	—	All 0	R	Reserved These bits are always read as 0. The write value should always be 0.
5, 4	—	All 1	R	Reserved These bits are always read as 1. The write value should always be 1.
3 to 1	—	All 0	R	Reserved These bits are always read as 0. The write value should always be 0.
0	—	1	R	Reserved This bit is always read as 1. The write value should always be 1.

25.4.23 PHY Interrupt Register (PHYINT)

PHYINT is a 32-bit register for making settings to do with interrupt signals and pins.

The settings of this register should be changed when the TEND flag in CMNSR is 1; otherwise, the operation cannot be guaranteed.

Bit	31	30	29	28	27	26	25	24	23	22	21	20	19	18	17	16
	—	—	—	—	—	RSTEN	WPEN	—	—	—	—	—	—	—	—	—
Initial Value	0	0	0	0	0	1	1	1	0	0	0	0	0	1	1	1
R/W	R	R	R	R	R	R/W	R/W	R	R	R	R	R	R	R	R	R
Bit	15	14	13	12	11	10	9	8	7	6	5	4	3	2	1	0
	—	—	—	—	—	—	—	—	—	—	—	—	—	RSTVAL	WPVAL	—
Initial Value	0	0	0	0	0	0	0	0	0	0	0	0	0	0	1	0
R/W	R	R	R	R	R	R	R	R	R	R	R	R	R	R/W	R/W	R

Bit	Bit Name	Initial Value	R/W	Description
31 to 27	—	All 0	R	Reserved These bits are always read as 0. The write value should always be 0.
26	RSTEN	1	R/W	QSPI_RESET# Pin Enable Enables or disables the QSPI_RESET# pin. 0: The QSPI_RESET# pin is disabled. 1: The QSPI_RESET# pin is enabled and the value specified in the RSTVAL bit is output.
25	WPEN	1	R/W	QSPI_WP# Pin Enable Enables or disables the QSPI_WP# pin. 0: The QSPI_WP# pin is disabled. 1: The QSPI_WP# pin is enabled and the value specified in the WPVAL bit is output.
24	—	1	R	Reserved When read, the initial value is read. When writing, be sure to write the initial value. Operation is not guaranteed if a value other than the initial value is written.
23 to 19	—	All 0	R	Reserved These bits are always read as 0. The write value should always be 0.
18 to 16	—	All 1	R	Reserved These bits are always read as 1. The write value should always be 1.
15 to 3	—	All 0	R	Reserved These bits are always read as 0. The write value should always be 0.
2	RSTVAL	0	R/W	Value Output through QSPI_RESET# Pin Specifies the value to be output through the QSPI_RESET# pin. This setting takes effect when the RSTEN bit is set to 1. 0: QSPI_RESET# = H 1: QSPI_RESET# = L
1	WPVAL	1	R/W	Value Output through QSPI_WP# Pin Specifies the value to be output through the QSPI_WP# pin. This setting takes effect when the WPEN bit is set to 1. 0: QSPI_WP# = H 1: QSPI_WP# = L
0	—	0	R	Reserved. Whenever it is read, 0 is read. The written value will be ignored.

25.4.24 PHY Adjustment Register 1 (PHYADJ1)

PHYADJ1 is a 32-bit register used to adjust the timing when serial flash memory is connected.

The settings of this register should be changed when the TEND flag in CMNSR is 1; otherwise, the operation cannot be guaranteed.

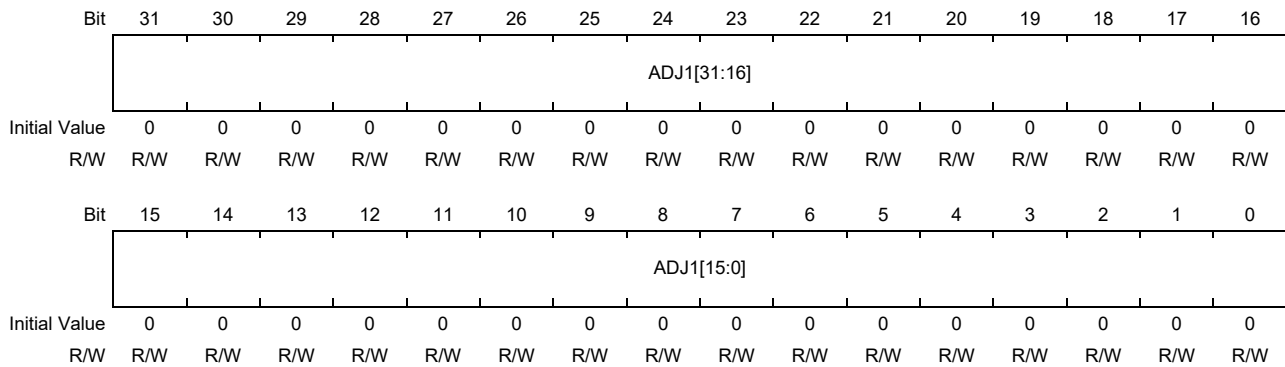

Bit	Bit Name	Initial Value	R/W	Description
31 to 0	ADJ1[31:0]	All 0	R/W	Serial Flash Memory Operation Timing Adjustment Before timing adjustment: Set these bits to H'80000000. During timing adjustment: Set these bits to H'80000032. <i>Note:</i> Do not set any value other than the specified ones.

25.4.25 PHY Adjustment Register 2 (PHYADJ2)

PHYADJ2 is a 32-bit register used to adjust the timing when serial flash memory is connected.

The settings of this register should be changed when the TEND flag in CMNSR is 1; otherwise, the operation cannot be guaranteed.

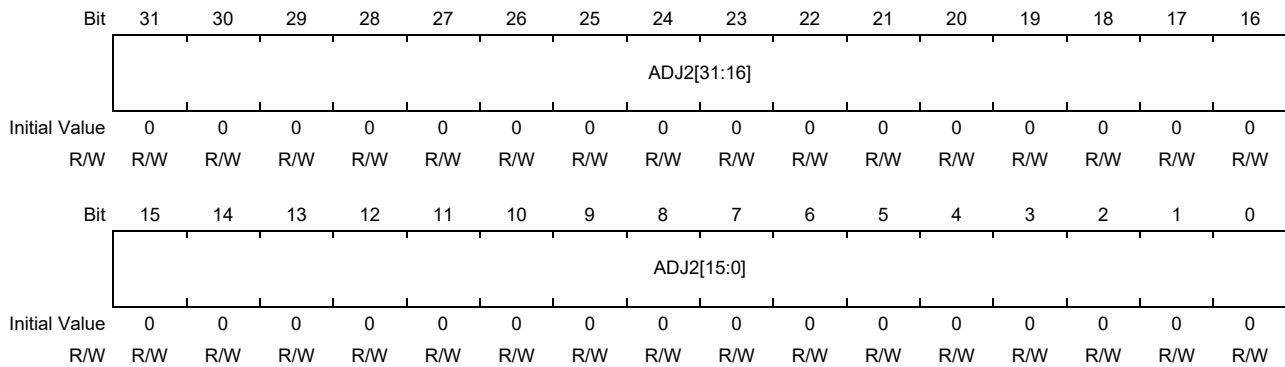

Bit	Bit Name	Initial Value	R/W	Description
31 to 0	ADJ2[31:0]	All 0	R/W	Serial Flash Memory Operation Timing Adjustment Before timing adjustment: Set these bits to H'A5390000. During timing adjustment: Set these bits by following the procedure shown in Figure 25.19, Flow of Timing Adjustment when the Serial Flash Memory is Connected (SDR Mode) and Figure 25.20, Flow of Timing Adjustment when the Serial Flash Memory is Connected (DDR Mode) . <i>Note:</i> Do not set any value other than the specified ones.

25.5 Operation

25.5.1 System Configuration

This module can connect one serial flash memory device.

Examples of system configuration are shown in **Figure 25.2**.

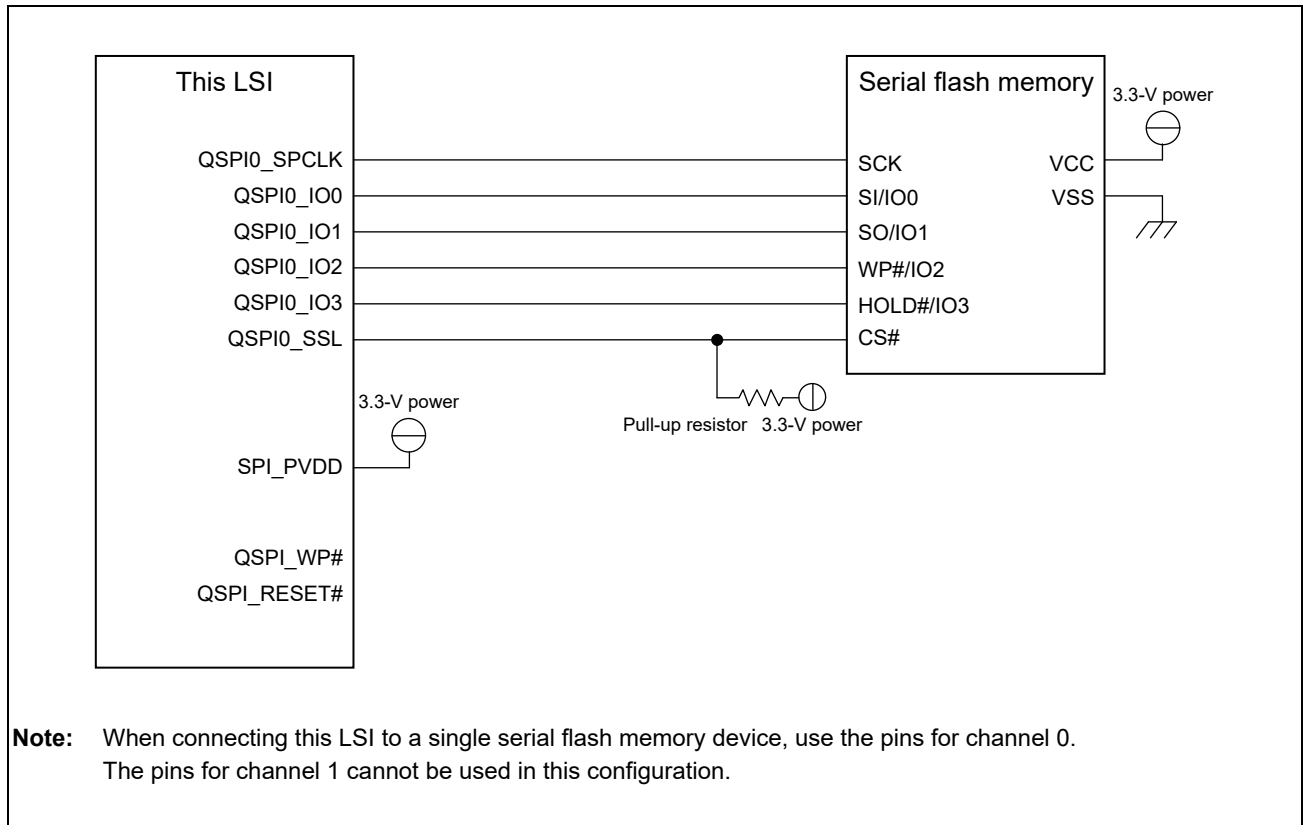

Figure 25.2 System Configuration Example with 4-Bit Data Size and One Serial Flash Memory Connected

25.5.2 Address Map

In external address space read mode, the serial flash connected is assigned in the SPI multi I/O bus space. In combination with DREAR, a maximum of 4 Gbytes can be accessed when one serial flash memory is connected.

Table 25.3 Address Map

Internal Address for AX45MP	Max. Access Area
H'0_20000000 to H'0_2FFFFFFF	One serial flash memory connected: 4 G-byte

Note: When access protection is set, not only this address space, but also the register area is protected.

25.5.3 32-bit Serial Flash Addresses

Since the SPI multi I/O bus space is 256 Mbytes, only a part of the 32-bit serial flash address area can be directly accessed. Here, the fixed value set in the pertinent register is used as the upper bit value of a 32-bit address.

To output serial flash addresses in 32 bits, set the ADE[3] bit in DRENr to 1, set the range of the external addresses used as the serial flash addresses to the EAC[2:0] bits in DREAR, and set the upper bit value of the 32-bit address as the fixed value to the EAV[7:0] bits in DREAR.

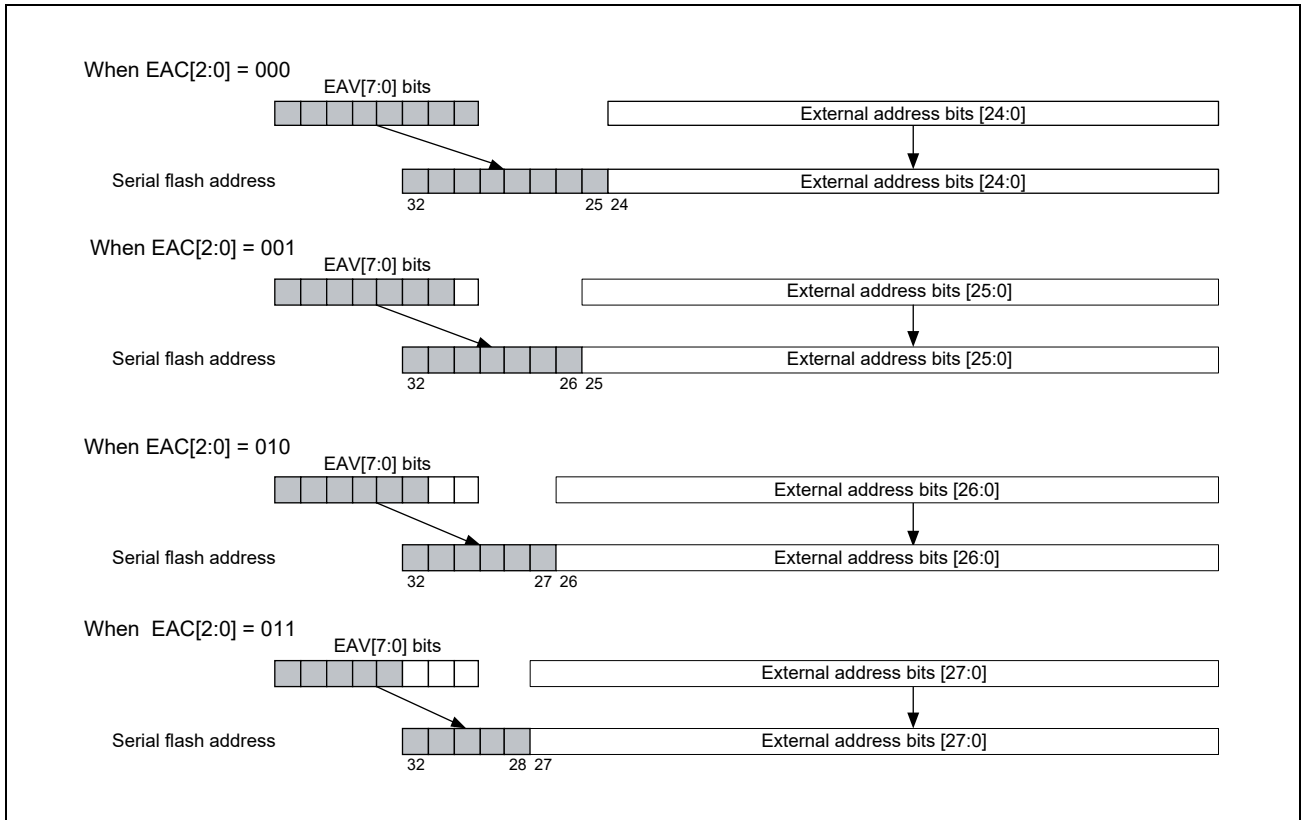

Figure 25.3 32-Bit Address Setting

Setting the ADE[3] bit in DRENr to 1 allows the serial flash address to be output using [31:0] bits.

When EAC[2:0] = 000, external address bits [24:0] are valid; set the value for [32:25] bits to EAV[7:0].

When EAC[2:0] = 001, external address bits [25:0] are valid; set the value for [32:26] bits to EAV[7:1].

When EAC[2:0] = 010, external address bits [26:0] are valid; set the value for [32:27] bits to EAV[7:2].

When EAC[2:0] = 011, external address bits [27:0] are valid; set the value for [32:28] bits to EAV[7:3].

The addresses actually used for external devices are as follows.

- Use the address [31: 0] when connecting one serial flash.

25.5.4 Operating Modes

This module has two operating modes: external address space read mode and Manual mode.

In external address space read mode, a read access to the SPI multi I/O bus space is converted into Data read protocol and data is received. After data acquisition, data is returned to the bus master that is the issuing source. For details, see **Section 25.5.5, External Address Space Read Mode**.

In Manual mode, arbitrary protocol is carried out using register settings. For details, see **Section 25.5.7, Manual mode**.

25.5.5 External Address Space Read Mode

A read access to the SPI multi I/O bus space can be converted into Data read protocol in external address space read mode. Further, the commands, optional commands, option data, and dummy cycle issued for reading can be modified using registers.

In external address space read mode, either normal read operation or burst read operation can be selected. The transfer format is determined based on the common control register (CMNCR), SSL delay register (SSLDR), data read control register (DRCR), data read command setting register (DRCMR), data read extended address setting register (DREAR), data read option setting register (DROPR), data read enable setting register (DRENr), data read dummy cycle setting register (DRDMCR), and data read DDR enable register (DRDRENr).

(1) Normal Read Operation

When the RBE bit in the DRCR register is set to 0, normal read operation is performed. In the normal read operation, data is read from the external device when the bus master executes read access. After data is read, the QSPIn_SSL pins are negated.

The timing of normal read operation for the serial flash memory is shown in **Figure 25.4**.

t_1 is the time period from QSPIn_SSL pin assertion to QSPIn_SPCLK oscillation (clock delay), t_2 is the time period from transmission of the last QSPIn_CLK edge of a transfer to QSPIn_SSL pin negation (QSPIn_SSL negation delay), and t_3 is the time period from one transfer end to the next transfer start (next access).

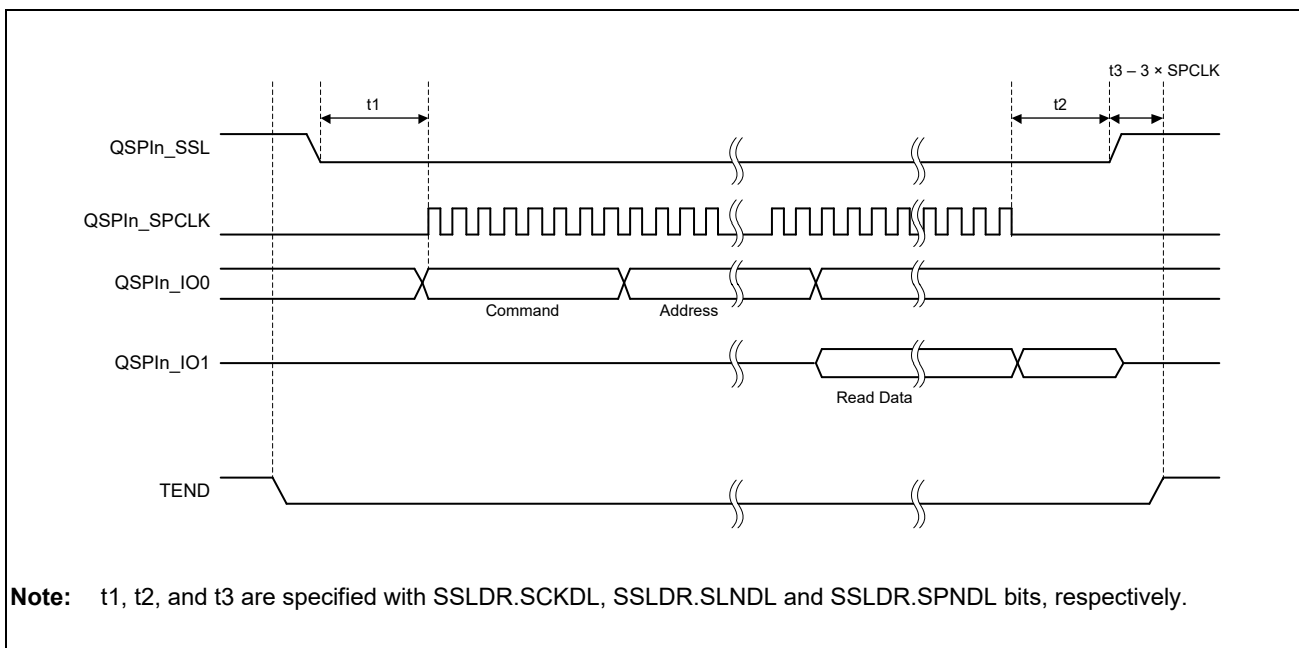

Figure 25.4 Normal Read Operation Timing

(2) Burst Read Operation

When the RBE bit in DRCCR is set to 1, burst read operation is performed.

Read cache is enabled in the burst read operation. For read cache operation, see **Section 25.5.6, Read Cache**.

When the bus master executes read access, the read cache is first searched for the target data. When the read cache contains the data, it is read from the cache instead of accessing the external device. When the read cache does not contain the data, the external device is read in the burst mode and the read data is stored in the read cache and returned to the bus master. In this operation, the data transfer length is 64 bits \times the value in the RBURST[4:0] bits, and data is always read from a 64-bit boundary address.

The QSPIn_SSL pin status after data transfer can be selected by using the SSLE bit in DRCCR. When the SSLE bit is set to 0, the QSPIn_SSL pin is negated after data transfer. For an operation performed when the SSLE bit is set to 1, see **Section 25.5.5(3), Burst Read Operation with Automatic QSPIn_SSL Negation**, just below.

A pattern diagram of this operation and a burst read operation timing diagram when SSLE bit is set to 0 are shown in **Figure 25.5** and **Figure 25.6**.

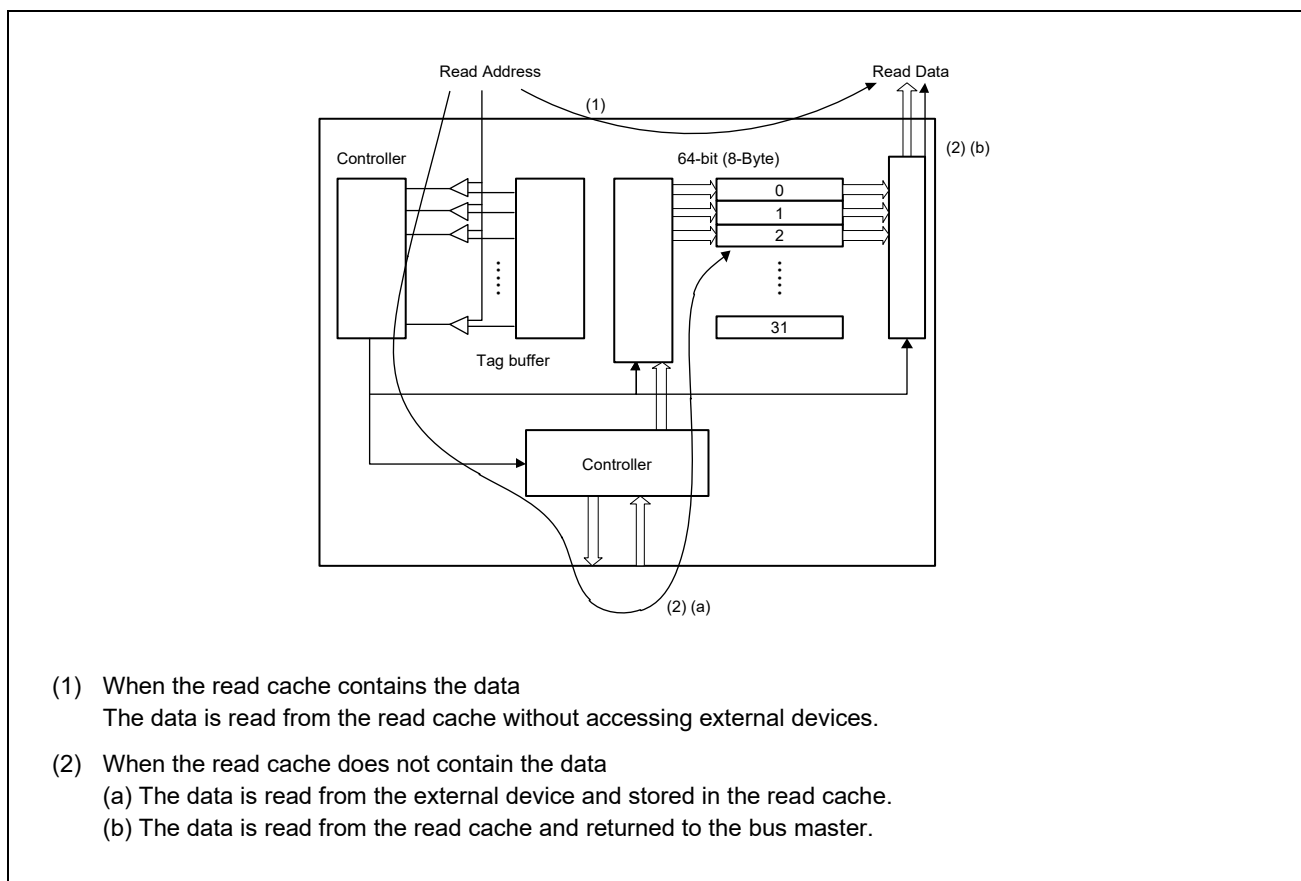

Figure 25.5 Burst Read Operation

NOTE

When connecting this LSI to a single serial flash memory device, use the pins for channel 0.

The pins for channel 1 cannot be used in this configuration.

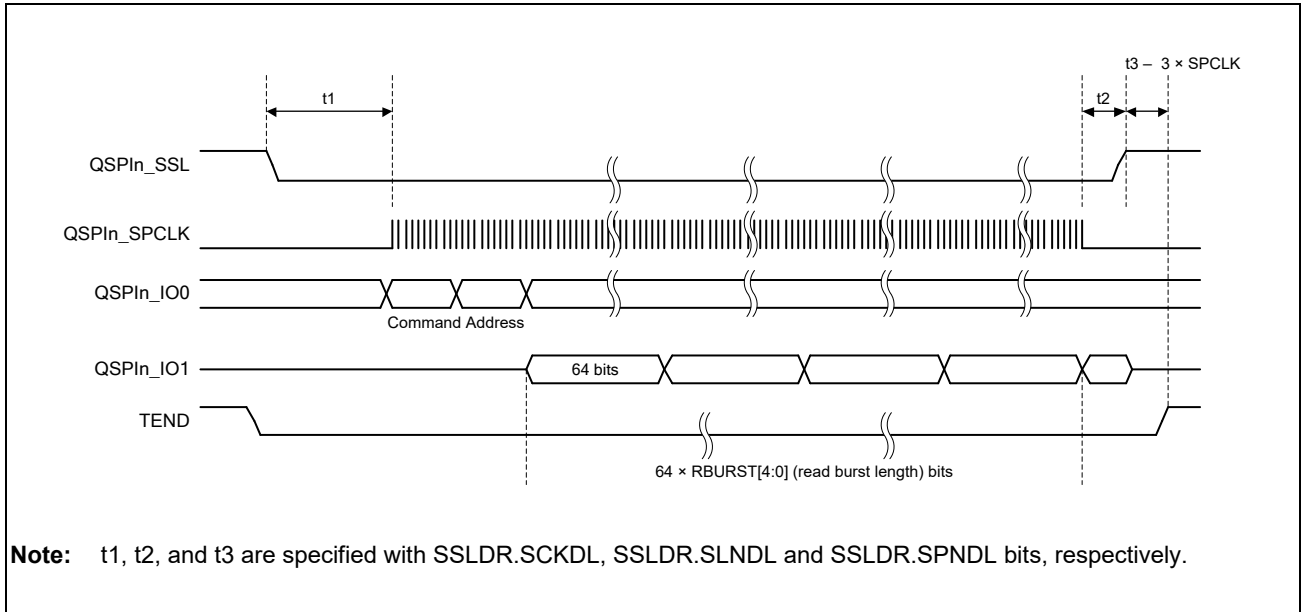

Figure 25.6 Burst Read Operation Timing

(3) Burst Read Operation with Automatic QSPIn_SSL Negation

When SSLE bit in DRCCR is set to 1, this module does not negate the QSPIn_SSL pin after the burst read transfer. When accessing the next time, if the address is continuous with the previous read address, the burst read operation is performed without issuing the command, optional command, address, option data, or dummy cycle. If the address is not continuous with the previous read address, the QSPIn_SSL pin is once negated and the burst read operation is performed after issuing the command, optional command, address, option data, or dummy cycle.

Burst read timing diagrams for continuous address and non-continuous address are shown in **Figure 25.7** and **Figure 25.8**.

For the next access after negation of the QSPIn_SSL with the SSLN bit in DRCCR with this operation, read SSLF = 0 in CMNSR to confirm that the QSPIn_SSL has been negated.

This function is available when serial flash memory is connected.

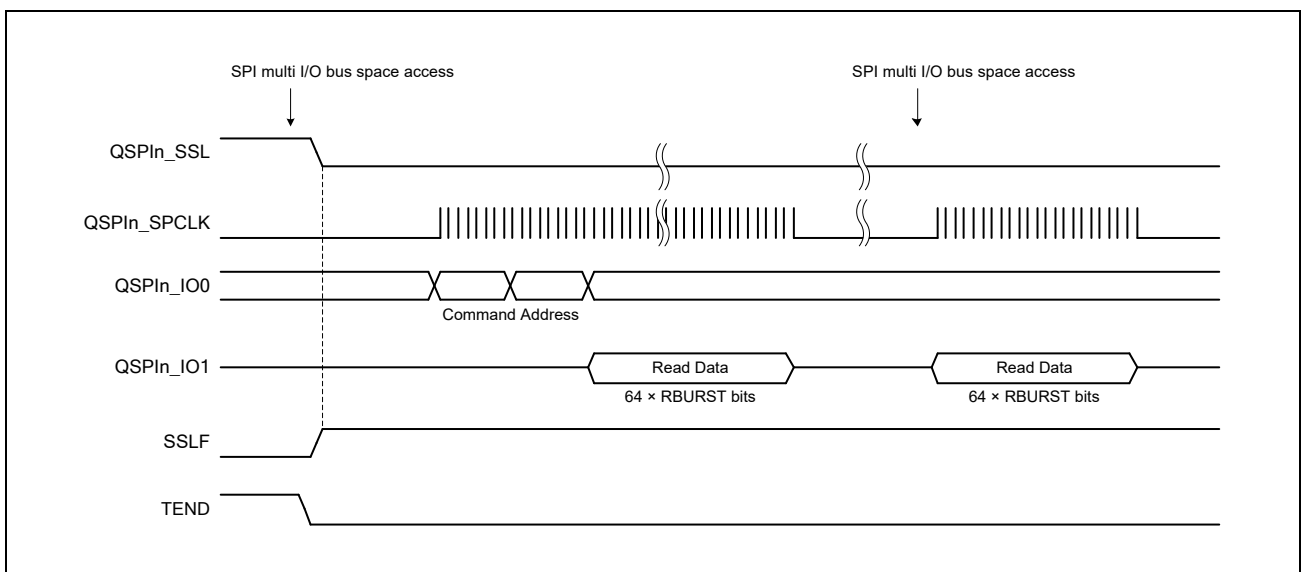

Figure 25.7 Burst Read Timing for Continuous Address (SSLE Bit = 1)

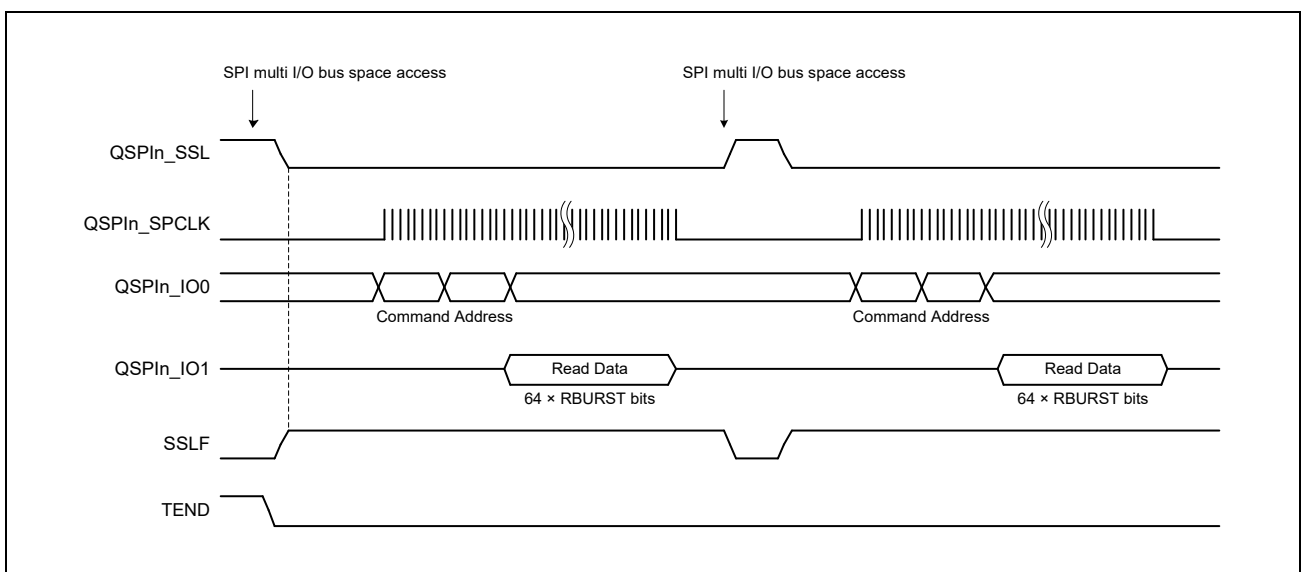

Figure 25.8 Burst Read Timing for Non-Continuous Address (SSLE Bit = 1)

(4) Initial Setting Flow

An example of an initial setting flow in external address space read mode is shown in **Figure 25.9**.

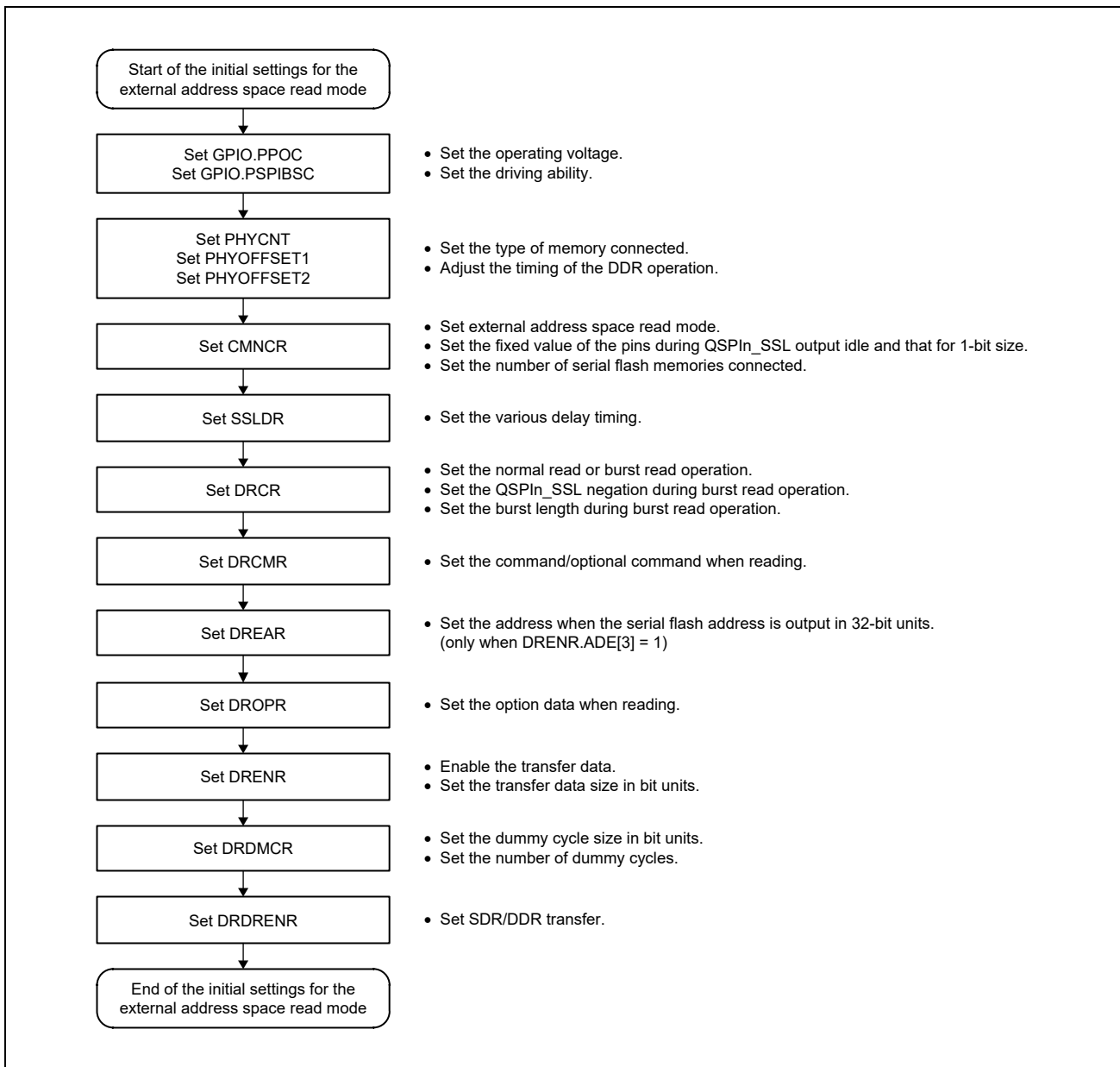

Figure 25.9 Example of Initial Setting Flow in External Address Space Read Mode

25.5.6 Read Cache

This module has a simple built-in read cache. The read cache can be used during external address space read mode and burst read operation. The read cache is configured with a line size of 64 bits and 32 entries.

Read cache configuration is shown in **Figure 25.10**.

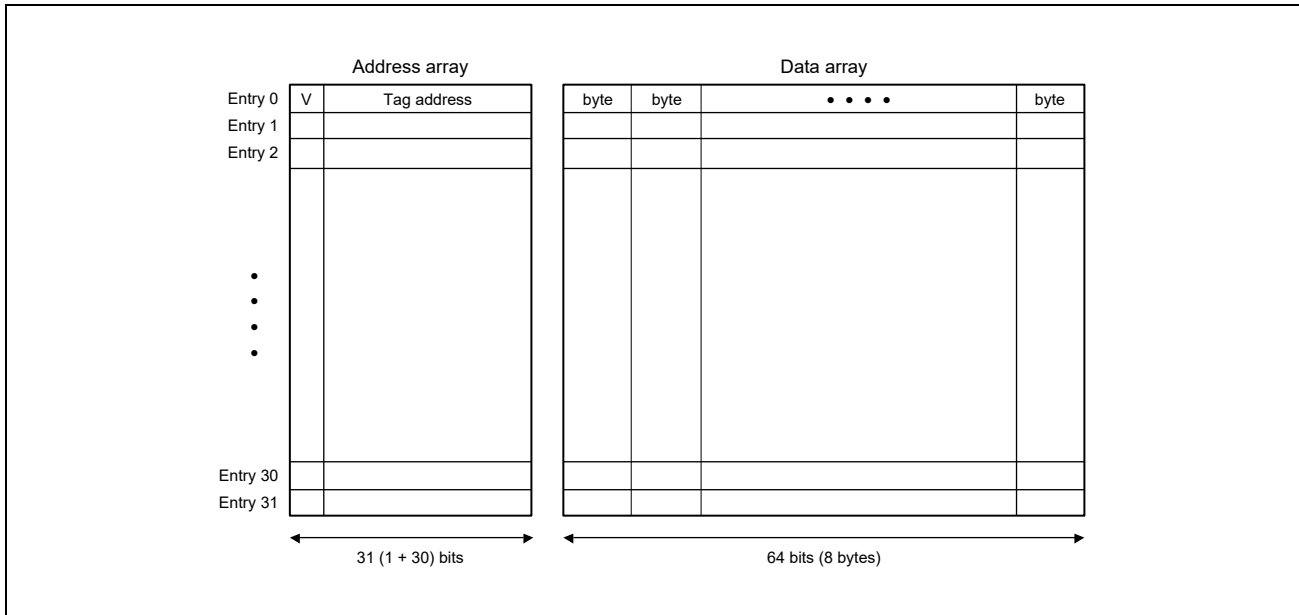

Figure 25.10 Read Cache Configuration

(1) Address Array

The V bit indicates whether the entry data is valid. When the V bit is 1, the data is valid and when V bit is 0, the data is invalid.

The tag address bits hold the address used for the serial flash memory. Address bits 32 to 3 are used for the purpose. Address bits 23 to 3 are enabled when address output is 24 bits and one serial flash memory is connected; and address bits 24 to 3 are enabled when two serial flash memories are connected.

Address bits 31 to 3 are enabled when address output is 32 bits and one serial flash memory is connected; and address bits 32 to 3 are enabled when two serial flash memories are connected.

(2) Data Array

It retains the 64-bit read data. Registration in the read cache is performed in line units.

(3) Read Operation

In case of read-hit, data is read from the read cache. In case of read-miss, after the $64 \times \text{RBURST}$ (read burst length) data is read from the serial flash memory and the read cache is updated, the data is returned to the bus master.

(4) Data Replacement

The write pointer is used to update data. In case of read-miss, the RBURST (read burst length) portion data is replaced starting at the entry specified by the write pointer. In other words, the data is replaced in the storage order of the data.

Whether data is referred to or not will not affect the replacement order of data.

25.5.7 Manual mode

This module can carry out an arbitrary serial transmission operation by using the register settings.

The transfer format is determined based on the common control register (CMNCR), SSL delay register (SSLDR), Manual mode control register (SMCR), Manual mode command setting register (SMCMR), Manual mode address setting register (SMADR), Manual mode option setting register (SMOPR), and Manual mode enable setting register (SMENR), Manual mode read data register (SMRDR), Manual mode write data register (SMWDR), Manual mode dummy cycle setting register (SMDMCR), and Manual mode DDR enable register (SMDRENR).

Manual mode can be used for reading the status of the serial flash memory and writing to the serial flash memory.

In this mode, one transfer refers to the operation from when the SPIE bit in SMCR is set to 1 to when the TEND bit is set to 1.

(1) Transfer Start

The transfer of data is started in the set transfer format by setting the SPIE bit in SMCR to 1. When write operation is enabled, the Manual mode write data register is transmitted to the serial flash memory. When read operation is enabled, data read from the serial flash memory is stored into the Manual mode read data register.

The Manual operation timing is shown in **Figure 25.11**.

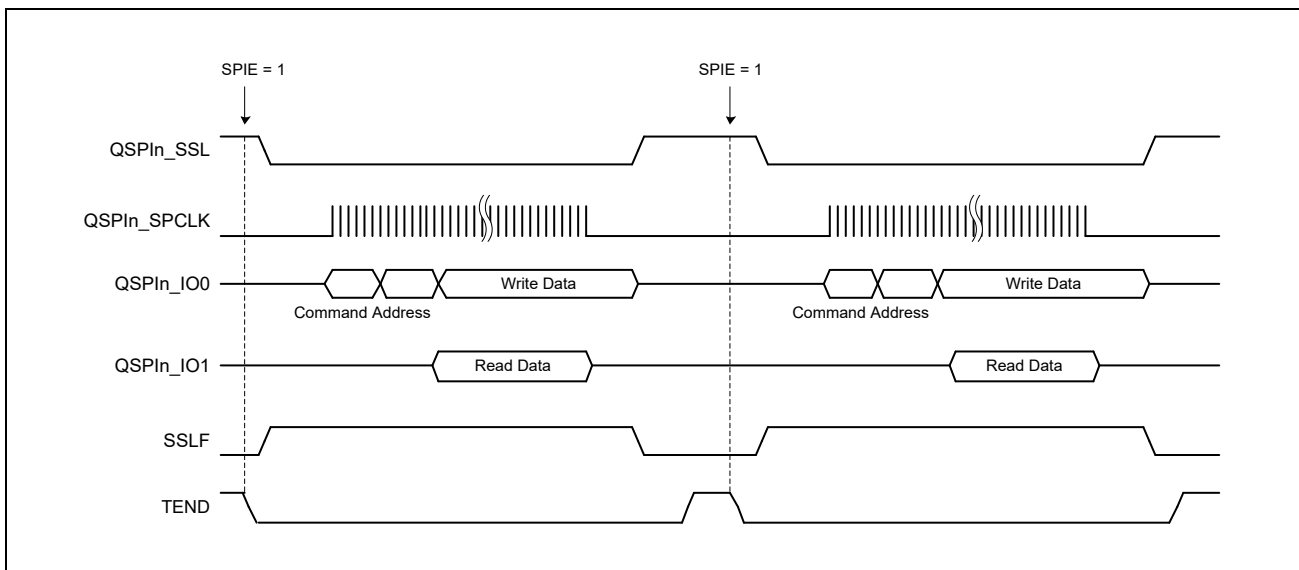

Figure 25.11 Serial transmission operation timing

(2) Read/Write Enable

- Read operation: Data can be read by setting the SPIRE bit in SMCR to 1. The read data is stored into SMRDR.
- Write operation: Data can be written by setting the SPIWE bit in SMCR to 1. The data stored in SMWDR is output.

When the data size is set to 1 bit using the SPIDB[1:0] bits in SMENR, data can be transmitted and received by setting the SPIRE and SPIWE bits to 1. However, when the data size is set to 4 bits by using the SPIDB[1:0] bits, only one of the SPIRE and SPIWE bits should be enabled. The operation is not guaranteed if the both bits are enabled.

(3) Retention of QSPIn_SSL Pin Assertion

By setting the SSLKP bit in SMCR to 1, assertion of the QSPIn_SSL pin can be continued till the next transfer. With this function, the transfer can be carried out continuously with the QSPIn_SSL kept in the asserted state.

The data transfer timing using the SSLKP bit is shown in **Figure 25.12**.

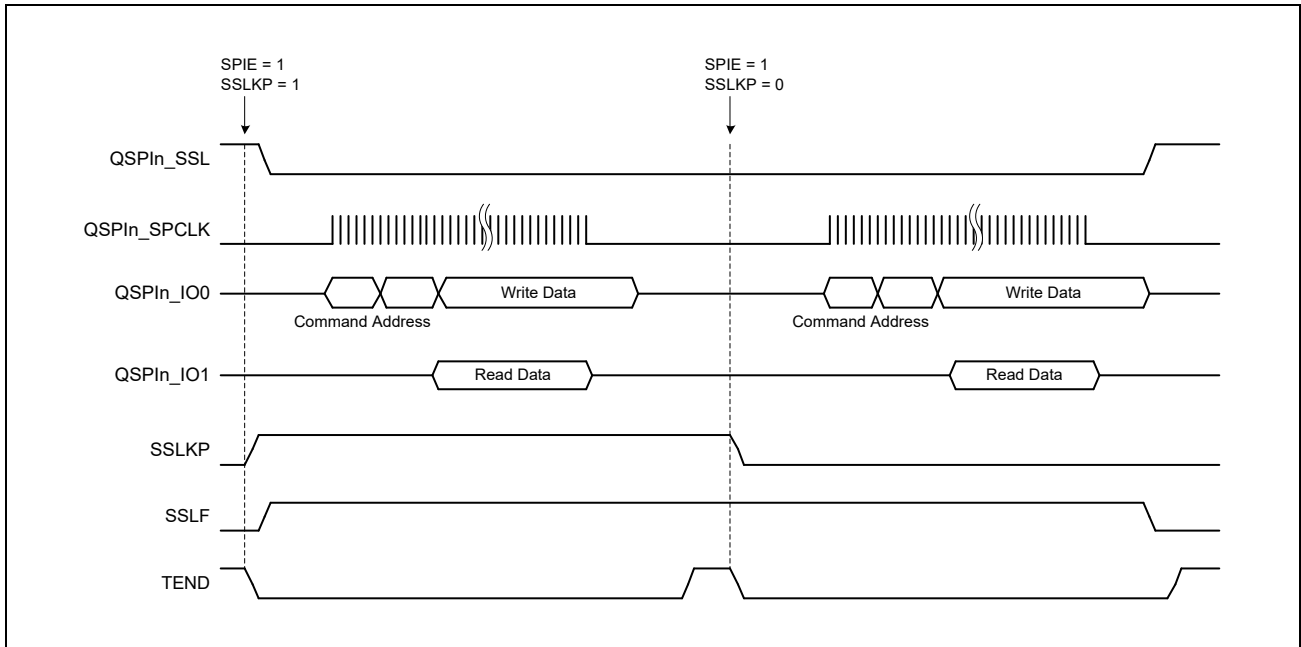

Figure 25.12 Data Transfer Timing using the SSLKP Bit

(4) Initial Setting Flow

An example of an initial setting flow in Manual mode is shown in **Figure 25.13**.

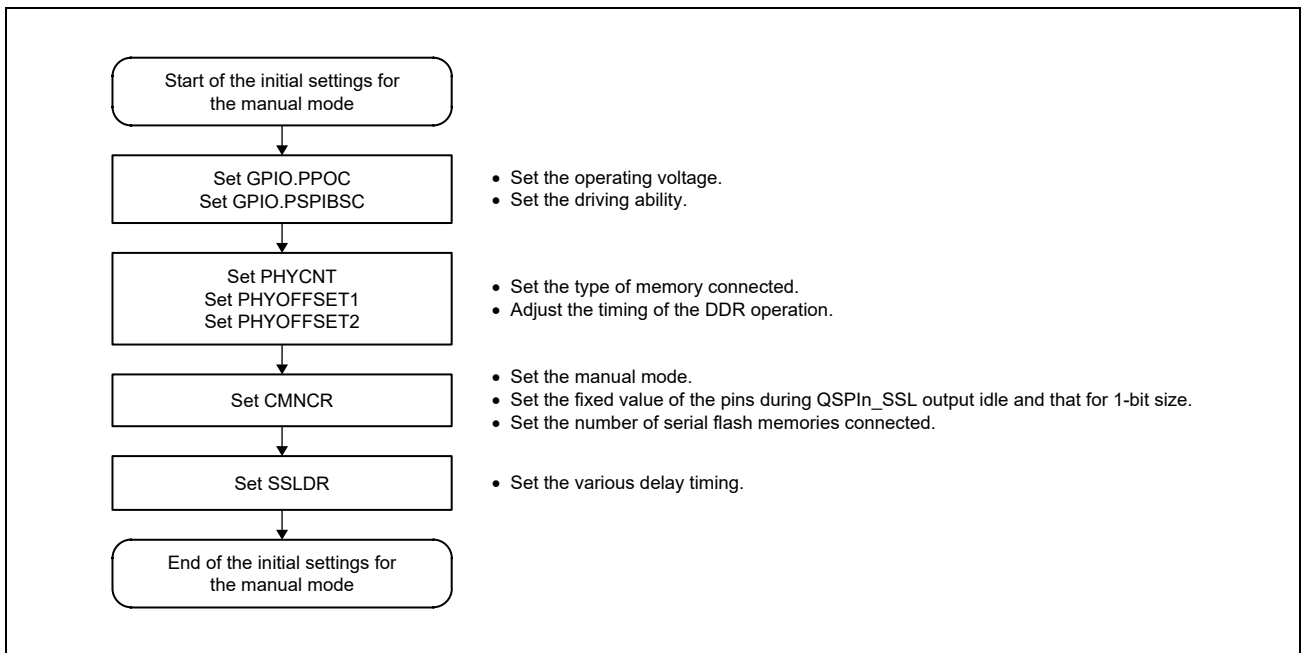

Figure 25.13 Example of Initial Setting Flow in Manual mode

(5) Data Transfer Setting Flow

An example of a data transfer setting flow in manual mode is shown in **Figure 25.14**.

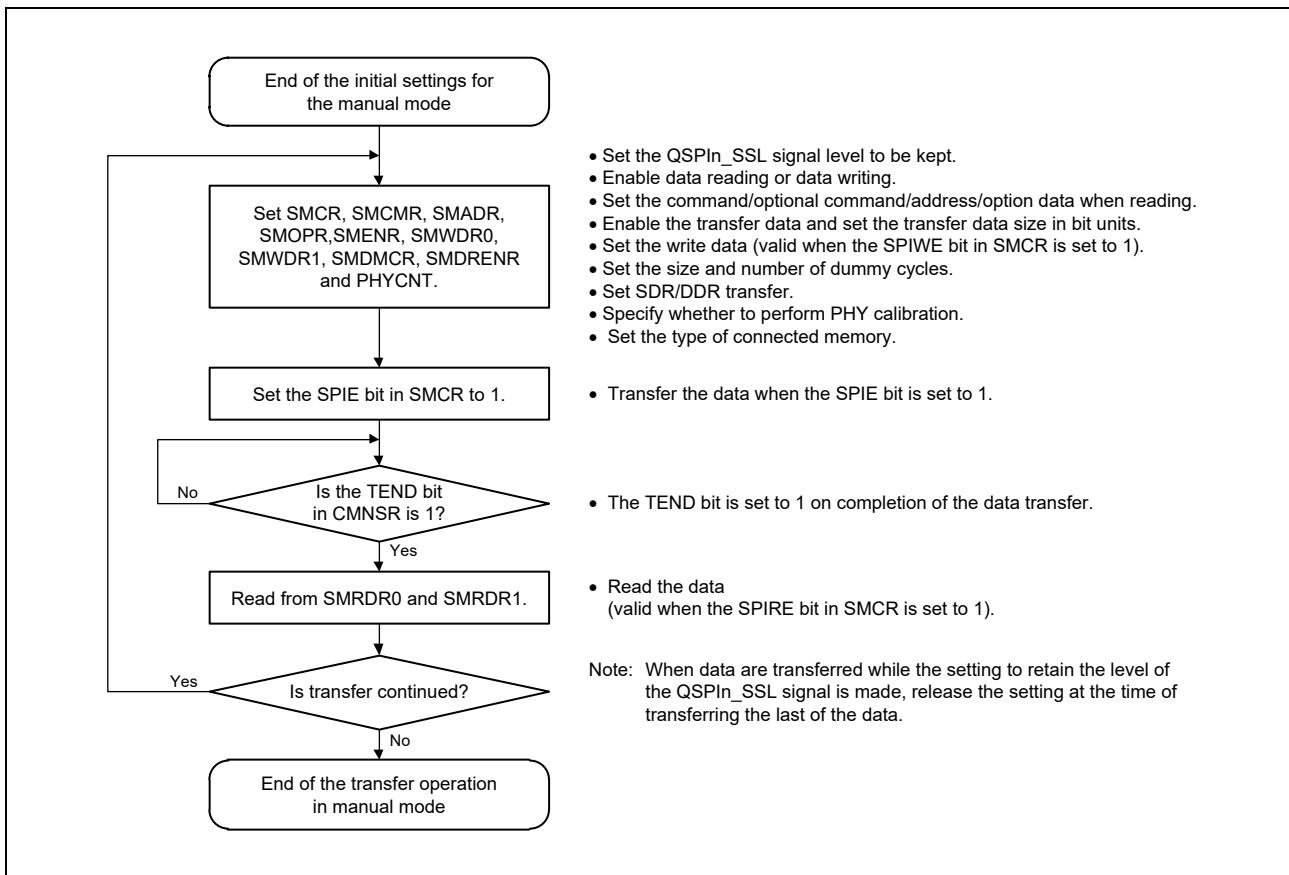

Figure 25.14 Example of a Data Transfer Setting Flow in Manual Mode

25.5.8 Command Sequence

This module can input and output data in the order of command, optional command, address, option data, dummy cycle, and data.

(1) Data Registers

Table 25.4 shows the input and output data.

Table 25.4 Data Registers

Data		External Address Space Read Mode	Manual Mode
Command (8 bits)		CMD[7:0] bits in DRCMR	CMD[7:0] bits in SMCMR
Optional command (8 bits)		OCMD[7:0] bits in DRCMR	OCMD[7:0] bits in SMCMR
Address (32/24 bits)	BSZ[1:0] = 00 (one flash memory connected)	32 bits: DREAR.EAV[6:3 to 0] bits + lower [27 to 24:0] bits of the read address.	32 bits: ADR[31:0] bits in SMADR
		24 bits: Lower [23:0] bits of the read address.	24 bits: ADR[23:0] bits in SMADR
Option data (8 bits × 4)		DROPR	SMOPR
Dummy cycle (2 to 20 cycles)		DRDMCR	SMDMCR (only when read)
Transfer data		Normal read: 8, 16, and 32 bits	Read: SMRDR0, SMRDR1
		Burst read: 64 × RBURST bits	Write: SMWDR0, SMWDR1

(2) Data Enable

In external address space read mode, enabling or disabling transfer of the command, optional command, address, option data, and dummy cycle can be controlled with the CDE, OCDE, ADE[3:0], OPDE[3:0], and DME bits in DRENr, respectively. The number of dummy cycles can be controlled with the data read dummy cycle setting register (DRDMCR).

Similarly, in manual mode, enabling or disabling the command, optional command, address, option data, dummy cycle, and transfer data can be controlled with the CDE, OCDE, ADE[3:0], OPDE[3:0], DME, and SPIDE[3:0] bits in SMENr, respectively. However, disabling all the above parameters is prohibited in manual mode. At least one of them except dummy cycle must be enabled. The number of dummy cycles can be controlled with the Manual mode dummy cycle setting register (SMDMCR).

For the address and option data in external address space read mode and the address, option data, and transfer data in manual mode, the enable bit setting allowed is determined according to the transfer data size. For the allowed setting combinations of the enable bits and transfer data size, refer to the description of the pertinent register.

If data is disabled, that data is skipped, and input and output of the next data is carried out. The command, optional command, address, and option data are always output. During dummy cycles, the state of the used pins is Hi-Z. In external address space read mode, data is always input; and in manual mode, input and output of data is determined based on the settings of the SPIRE and SPIWE bits in SMCR.

There are some restrictions on dummy cycle insertion; refer to the description of the DME bits in DRENr and SMENr for details.

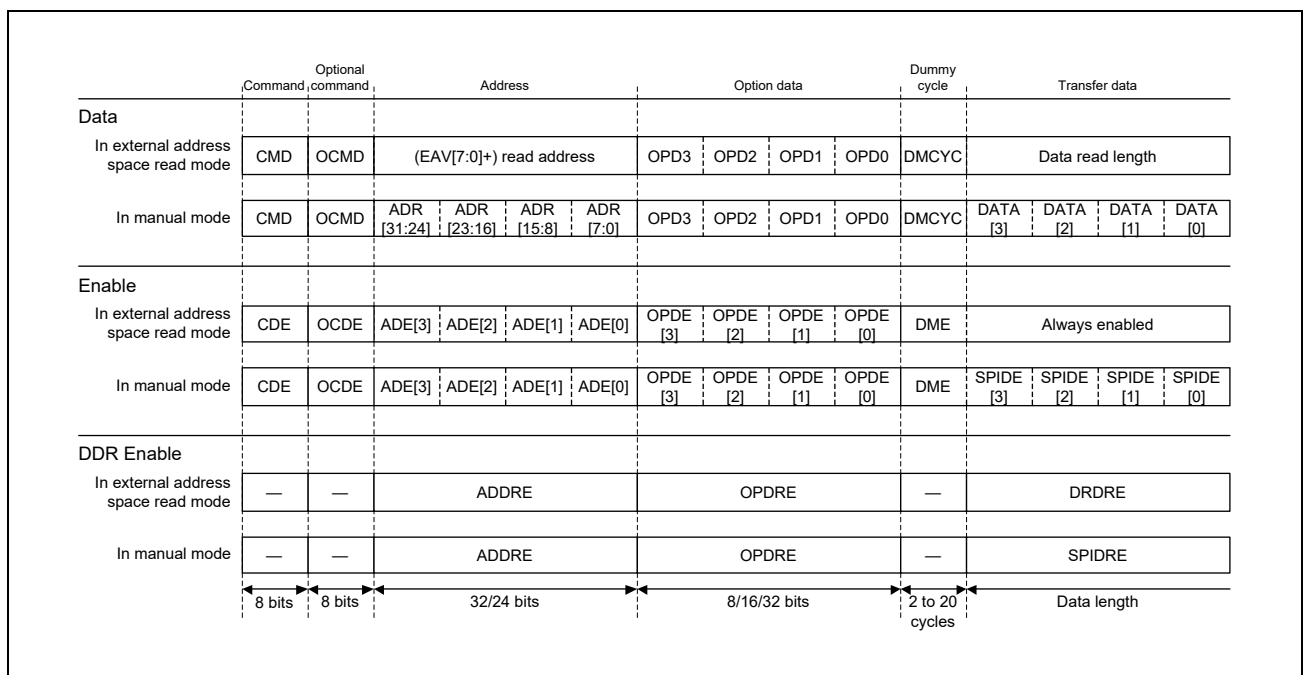

Figure 25.15 Data and Enable (Serial Flash)

(3) Bit Size

In external address space read mode, the size of the command, optional command, address, option data, and the read data in bit units is respectively controlled with the CDB[1:0], OCDB[1:0], ADB[1:0], OPDB[1:0], and DRDB[1:0] bits in DRENr.

Similarly, in manual mode, the size of the command, optional command, address, option data, and read write data in bit units is controlled with the CDB[1:0], OCDB[1:0], ADB[1:0], OPDB[1:0], and SPIDB[1:0] bits in SMENr.

(a) 1-bit Size

When the size is set to 1 bit, QSPI0_IO1 pin will be the input pin and QSPI0_IO0 pin will be the output pin. QSPI0_IO2 and QSPI0_IO3 pins are not used.

Figure 25.16 show the transfer format examples.

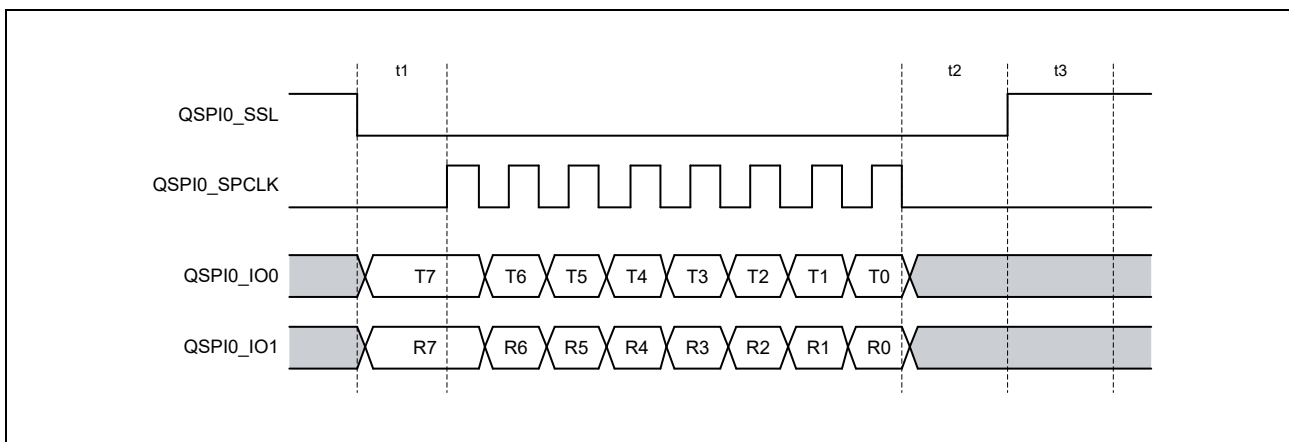

Figure 25.16 Transfer Format Example with 1-Bit Data Size and One Serial Flash Memory Connected

(b) 4-bit Size (Serial Flash)

When the size is set to 4 bits, QSPI0_IO0, QSPI0_IO1, QSPI0_IO2, and QSPI0_IO3 pins will be either the input pins or the output pins.

Figure 25.17 show the transfer format examples.

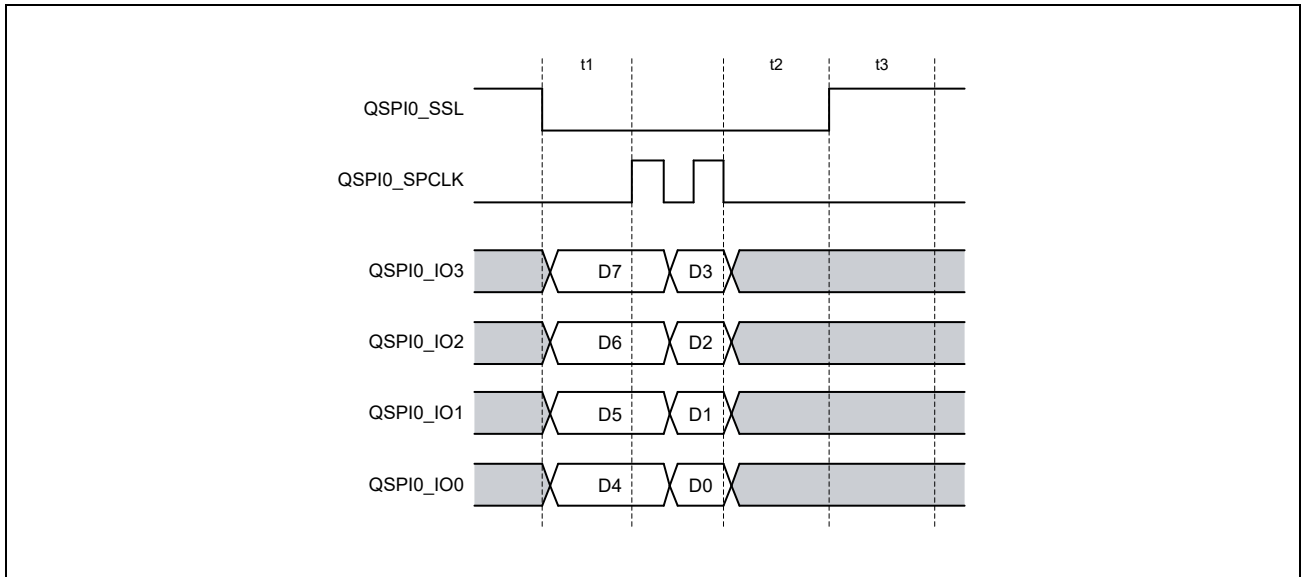

Figure 25.17 Transfer Format Example with 4-Bit Data Size and One Serial Flash Memory Connected

25.5.9 Data Pin Control

With this module, the status of pins can be automatically changed based on the data size to be used and the read/write settings. The pin status during the QSPIn_SSL negation can be set with the MOIIO3, MOIIO2, MOIIO1, and MOIIO0 bits in CMNCR. The QSPIn_SSL and QSPIn_SPCLK pins are always output pins.

The status of respective pins is specified in **Table 25.5** to **Table 25.8**.

Table 25.5 Pin Status (1)

Pin	QSPIn_SSL Negation	QSPIn_SSL Assertion	
		Command, Optional Command, Address, Option Data	
		1-bit Size	4-bit Size
QSPI0_IO0	MOIIO0 bit value	Output	Output
QSPI0_IO1	MOIIO1 bit value	Hi-Z	Output
QSPI0_IO2	MOIIO2 bit value	IO2FV bit value	Output
QSPI0_IO3	MOIIO3 bit value	IO3FV bit value	Output

Table 25.6 Pin Status (2)

Pin	Transfer Data			
	External Address Space Read Mode		SPI Operation	
	1-bit Size	4-bit Size	SPIRE Bit = 1, SPIWE Bit = 0	
			1-bit Size	4-bit Size
QSPI0_IO0	IO0FV bit value	Input	IO0FV bit value	Input
QSPI0_IO1	Input	Input	Input	Input
QSPI0_IO2	Hi-Z	Input	Hi-Z	Input
QSPI0_IO3	Hi-Z	Input	Hi-Z	Input

Table 25.7 Pin Status (3)

Pin	Transfer Data			
	SPI Operation			
	SPIRE Bit = 0, SPIWE Bit = 1		SPIRE Bit = 1, SPIWE Bit = 1	
	1-bit Size	4-bit Size	1-bit Size	4-bit Size
QSPI0_IO0	Output	Output	Output	Setting prohibited
QSPI0_IO1	Hi-Z	Output	Input	Setting prohibited
QSPI0_IO2	IO2FV bit value	Output	IO2FV bit value	Setting prohibited
QSPI0_IO3	IO3FV bit value	Output	IO3FV bit value	Setting prohibited

Table 25.8 Pin Status (4)

Pin	Dummy Cycle
QSPI0_IO0	IO0FV bit value
QSPI0_IO1	Hi-Z
QSPI0_IO2	Hi-Z
QSPI0_IO3	Hi-Z

25.5.10 QSPIn_SSL Pin Control

Negation conditions of the QSPIn_SSL pin are as follows.

(1) External Address Space Read Mode

(a) Normal read operation (RBE bit in DRCCR = 0)

QSPIn_SSL negated after completing the data transfer and t2 cycle.

(b) Burst read without automatic QSPIn_SSL negation (RBE bit in DRCCR = 1, SSLE bit in DRCCR = 0)

QSPIn_SSL negated after completing the data transfer and t2 cycle.

(c) Burst read with automatic QSPIn_SSL negation (RBE bit in DRCCR = 1, SSLE bit in DRCCR = 1)

- QSPIn_SSL negated after t2 cycle when the read address is not continuous with the previously read address
- QSPIn_SSL negated after the SSLN bit in DRCCR is set to 1

(2) Manual Mode

(a) QSPIn_SSL pin assertion not retained (SSLKP bit in SMCR = 0)

QSPIn_SSL negated after completing the data transfer and t2 cycle.

(b) QSPIn_SSL pin assertion retained (SSLKP bit in SMCR = 1)

QSPIn_SSL not negated.

When to be negated, data should be transferred after setting the SSLKP bit to 0.

25.5.11 Flags

This module has two flag bits SSLF and TEND in CMNSR. These bits are read-only bits.

(1) SSLF Bit

This bit indicates the QSPIn_SSL pin status. The status is 1 when the QSPIn_SSL is asserted, and the status is 0 when the QSPIn_SSL is negated.

(2) TEND Bit

This bit indicates whether transfer of data is in progress or the transfer of data has ended.

During t1 time period, data transfer, t2 time period, t3 time period, and waiting for read access by burst read and QSPIn_SSL automatic negation, the TEND bit is read as 0 to indicate that the transfer of data is in progress.

Otherwise, the TEND bit is read as 1 to indicate that transfer of data has ended.

(3) Register Re-writing Timing

The status of the TEND bit determines the rewritable registers.

The registers which can be written to, except the SSLN bit in DRCCR, should be modified when TEND = 1. Read SMRDR0 and SMRDR1 when TEND = 1. CMNSR can always be read.

25.5.12 Write Buffer Operation

This module uses the read cache space also as the write buffer space during write operation. The write buffer improves the performance of write access.

Table 25.9 Write Buffer Space

Address for AX45MP	Access Size
H'0_1007 0000 ~ H'0_1007 00FF	4, 8, 16, 32, or 64 bytes

Note: Be sure to sequentially access this space beginning from its start address with the transfer size set to eight bytes.
If access is non-sequential or random, correct operation is not guaranteed.
After an operation in Manual mode or with the use of the cache area as the write buffer, clearing of this cache area by writing 1 to the RCF bit is required.

Figure 25.18 shows the procedure for using the write buffer. For the initial settings in Manual mode, see **Figure 25.13**.

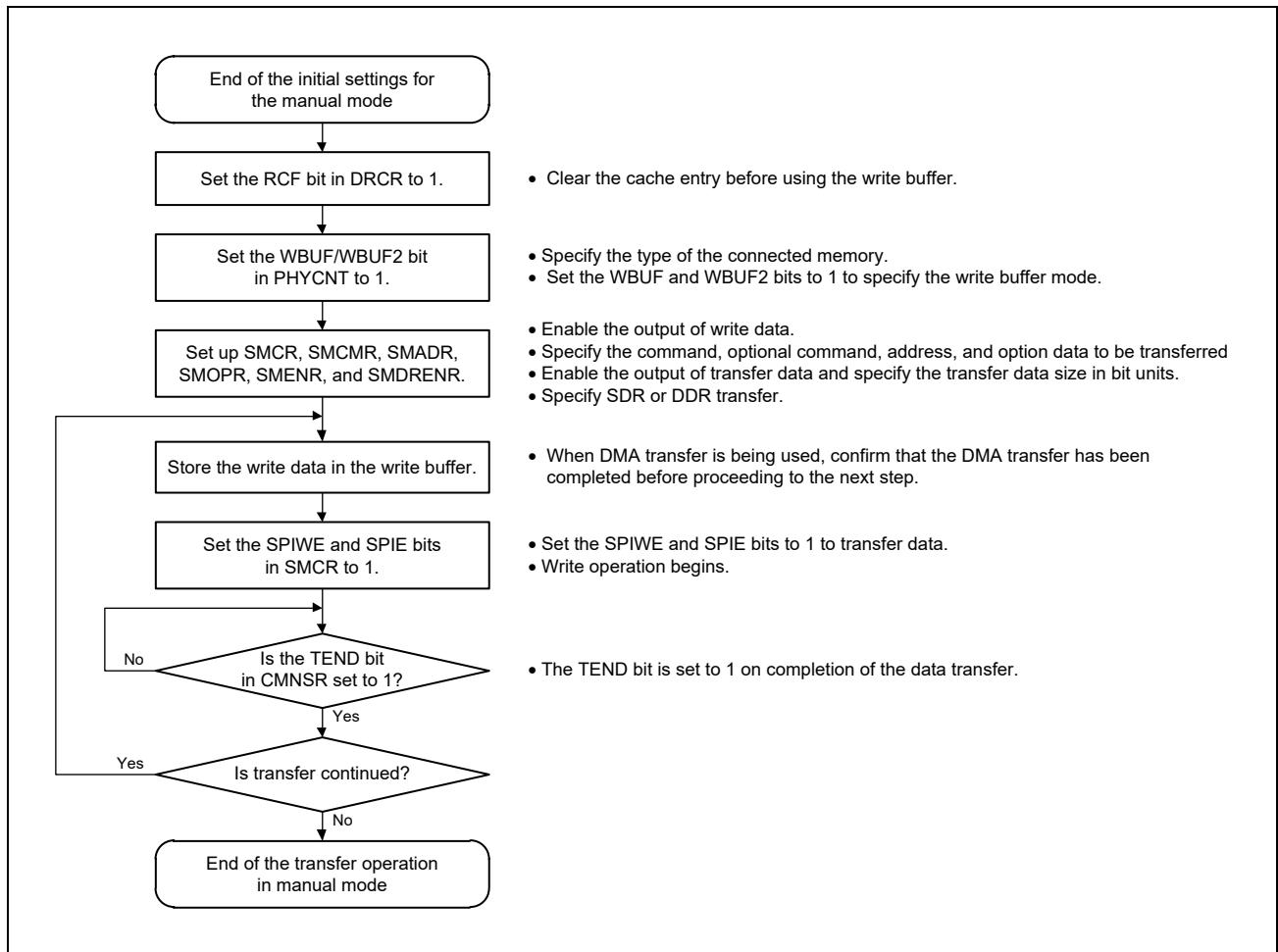

Figure 25.18 Procedure for Using the Write Buffer

25.5.13 Supported Protocol for Serial Flash Memory

The protocol for serial flash memory that this LSI supports is indicated in **Table 25.10**.

Table 25.10 Supported Protocol for Serial Flash Memory

Bit Width (Command-Address-Data)	Command	Address	Data
1-0-0	SDR	NA	NA
1-0-1	SDR	NA	SDR
1-1-1	SDR	SDR	SDR
	SDR	DDR	DDR
1-1-4	SDR	SDR	SDR
1-4-4	SDR	SDR	SDR
	SDR	DDR	DDR

25.5.14 Timing Adjustment

When data is transferred with serial flash memory connected, adjustment of the timing between the clock operation and the acquisition of input data is required.

Figure 25.19 shows the timing adjustment flow for serial flash (SDR mode) connection.

Execute this flow before changing the setting of SCLKSEL.SPICR[1:0] from its initial value when the serial flash memory is connected (SDR mode). Execution of this flow at regular intervals is not required.

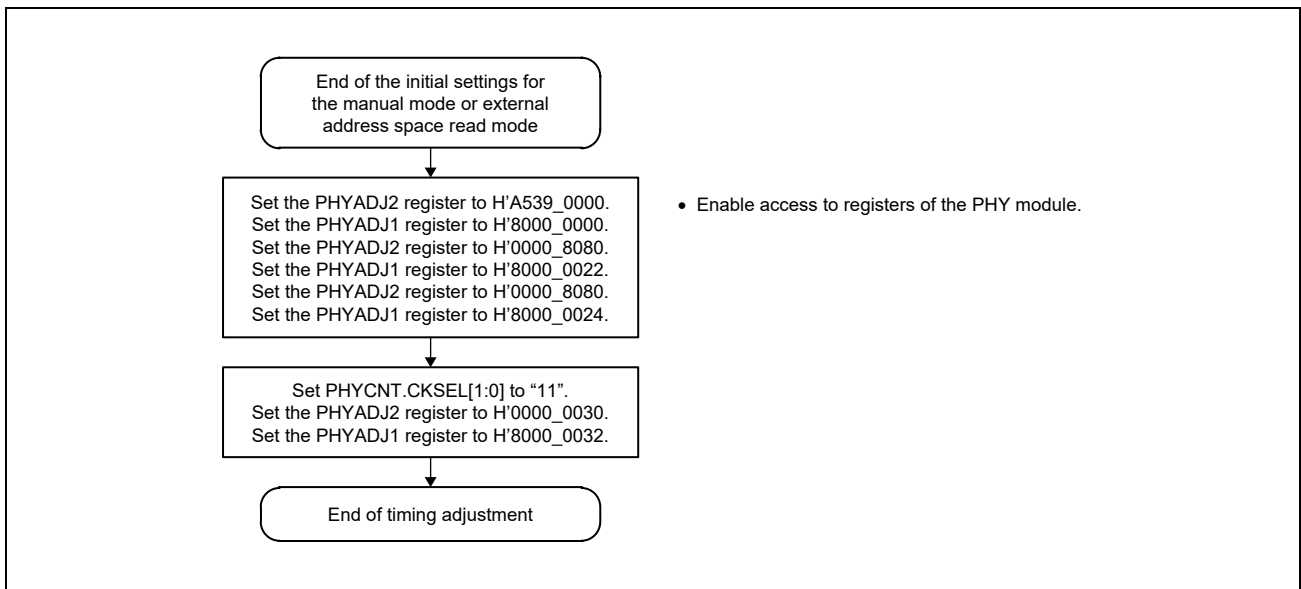

Figure 25.19 Flow of Timing Adjustment when the Serial Flash Memory is Connected (SDR Mode)

Figure 25.20 shows the timing adjustment flow for serial flash (DDR mode) connection.

Since the set value acquired in this timing adjustment flow is affected by voltage and temperature variation, this flow should be performed periodically.

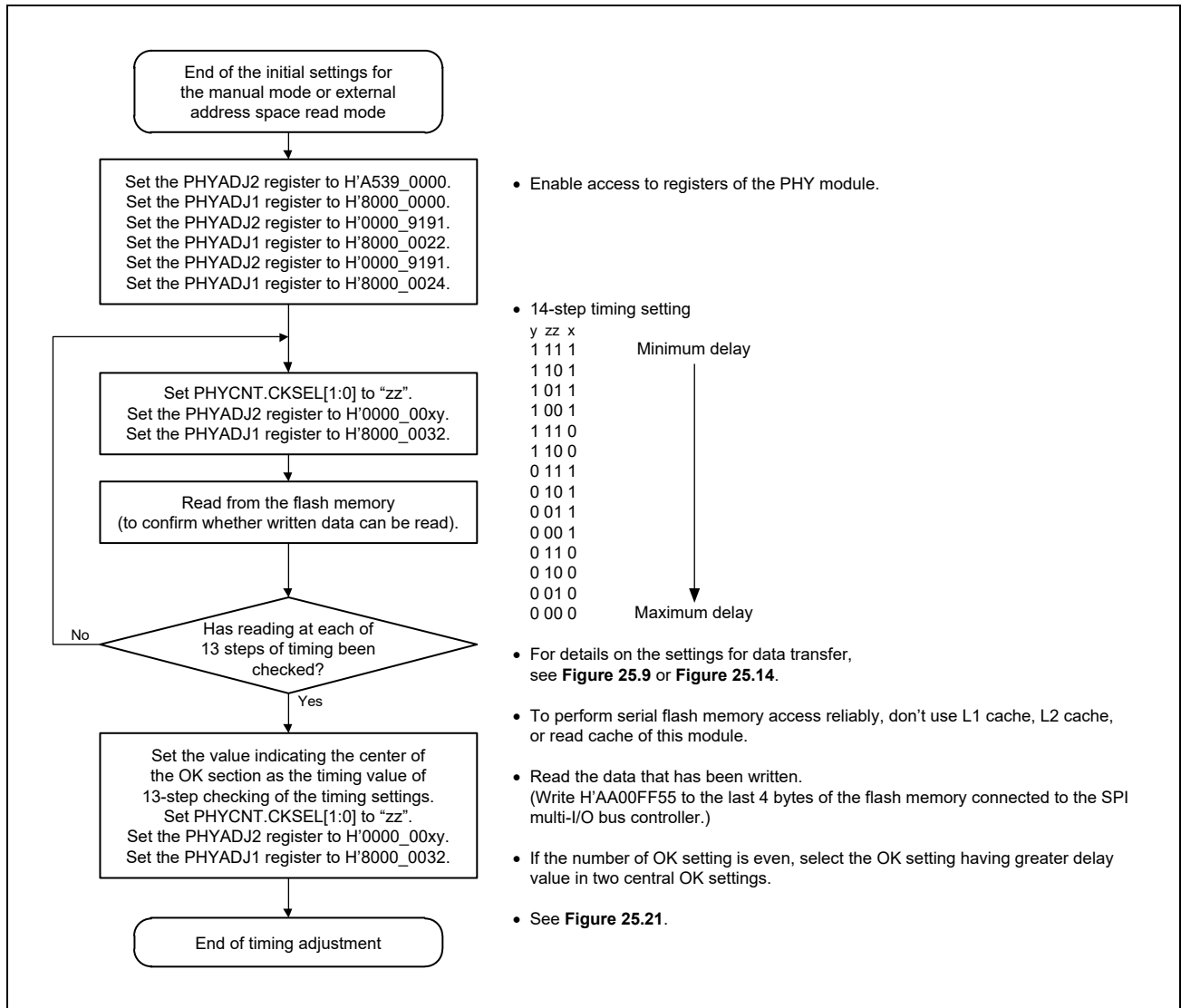

Figure 25.20 Flow of Timing Adjustment when the Serial Flash Memory is Connected (DDR Mode)

Figure 25.21 shows an example of timing setting for serial flash (DDR mode) connection.

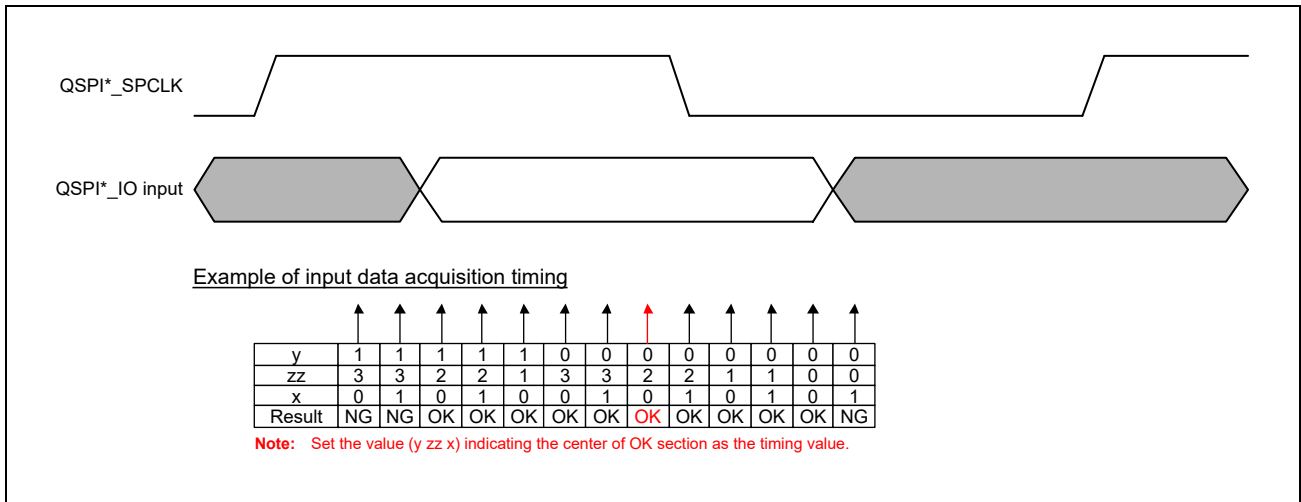

Figure 25.21 Example of Timing Adjustment when the Serial Flash Memory is Connected (DDR Mode)

25.5.15 Data Alignment

Data alignments in external address space read mode and Manual mode are shown in **Figure 25.22** and **Figure 25.23**, respectively. When two serial flash memory devices are connected, the addresses of one device connected to pins QSPI0_IO0 to QSPI0_IO3 are treated as $2n$ and those of the other device connected to pins QSPI1_IO0 to QSPI1_IO3 are treated as $2n + 1$. Be sure that access is in at least word units. Access in byte units is not supported.

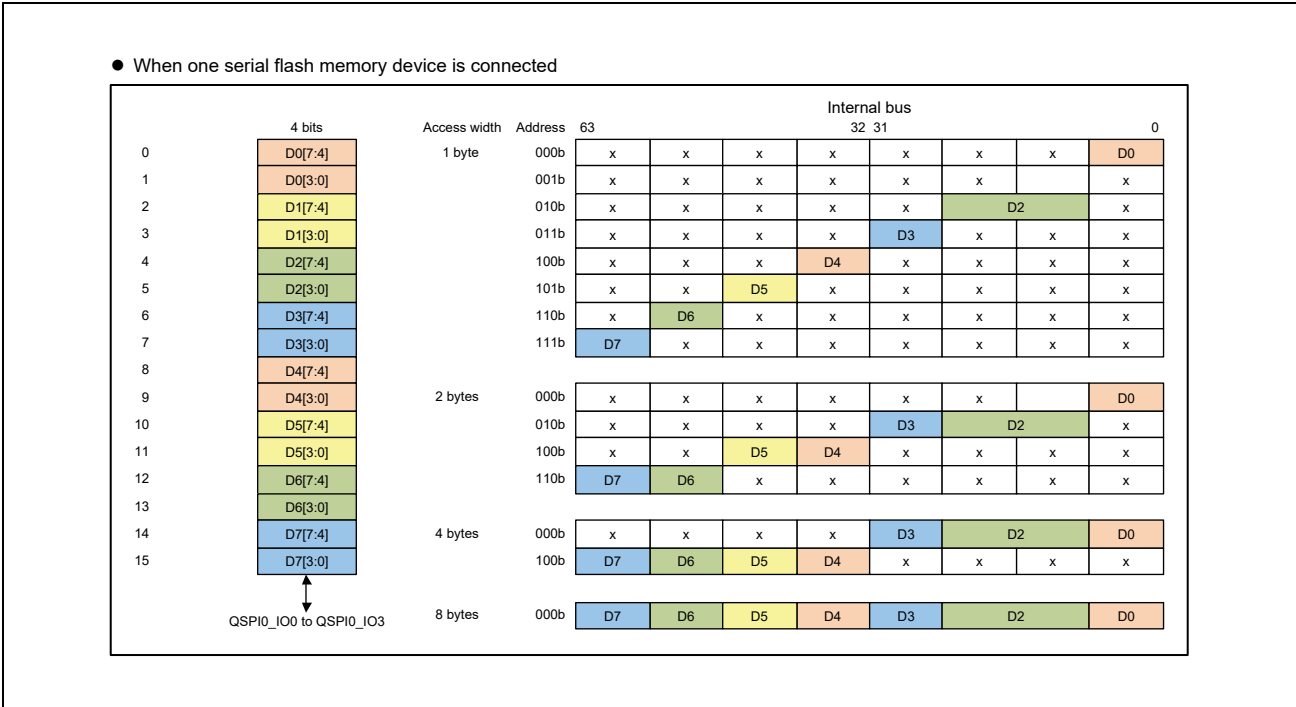

Figure 25.22 Data Alignment in External Address Space Read Mode

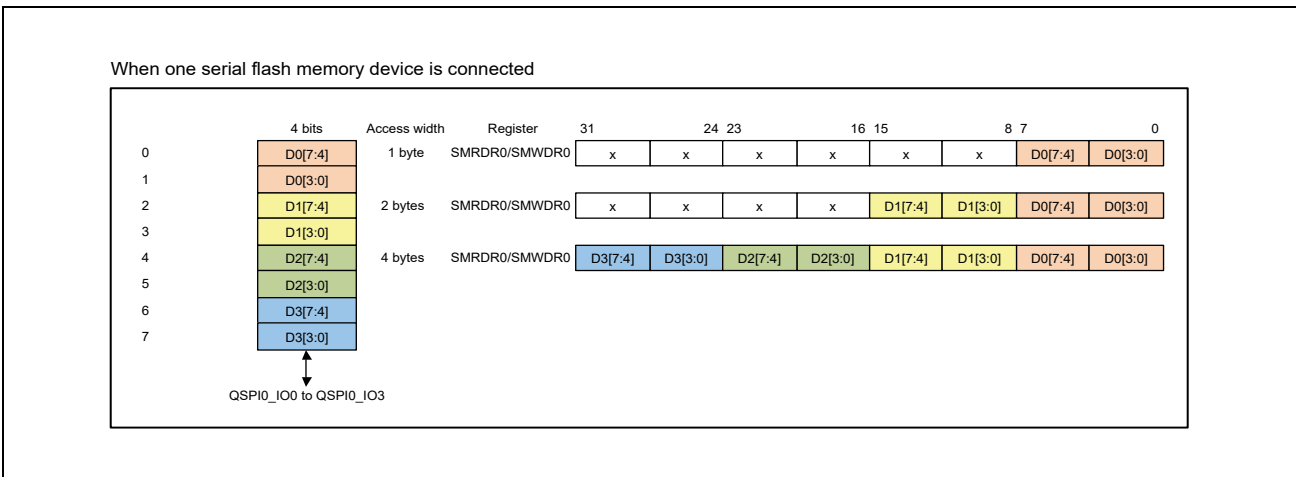

Figure 25.23 Data Alignment in Manual Mode

25.6 Usage Notes

25.6.1 Transfer to read data while the signal on the QSPIn_SSL pin is de-asserted

Set the SMENR.SPIDE[3:0] bits to 1100 or 1111 when transfer only for reading data is to proceed.

Transfer will not proceed normally if the setting of the SMENR.SPIDE[3:0] bits is 1000.

25.6.2 Transfer to read data while the signal on the QSPIn_SSL pin is asserted

When transfer only for reading data is to proceed, set the SMENR.SPIDE[3:0] bits to 1100 or 1111, or end the immediately preceding transfer with reading data.

When the immediately preceding transfer is of a command, optional command, address, or option data, or is transfer for writing data, the subsequent transfer only for reading data will not proceed normally if the setting of the SMENR.SPIDE[3:0] bits is 1000.

25.6.3 Notes on Starting Transfer from the QSPIn_SSL Retained State in Manual Mode

Be sure to set the SPIWE bit in the SMCR register to 1 when the transfer of a command, optional command, address, or option data is started while the QSPIn_SSL pin is being asserted in Manual mode.

In addition, while the QSPIn_SSL signal is being asserted in Manual mode, the setting to start data transfer for reading is prohibited.

25.6.4 Handling of QSPI_RESET#

The state of the QSPI_RESET# pin can be changed in the following two ways.

1. Use the RSTEN and RSTVAL bits in the PHYINT register.
The state of the QSPI_RESET# pin depends on the value of the RETVAL bits in the PHYINT register.
2. Activate the reset to this module.
While a power-on reset or a software reset is applied to this LSI, the signal on the QSPI_RESET# pin goes low.
When the reset is deactivated, the signal on the QSPI_RESET# pin goes high.

25.6.5 Software Reset after Release from the Module Stop State

When resetting SPI Multi I/O using the CPG reset ON/OFF register, set the clock ON/OFF register to ON before releasing the reset to supply the clock. While the SPI Multi I/O is in the reset state, the state of the QSPI_RESET# pin is L. Guarantee the reset period and accessible period after reset required by the connected device.

26. I²C Bus Interface

This section gives an overall description of the I²C bus interface (RIIC).

The first section describes the features specific to this LSI, including the number of units and the register base addresses. The subsequent sections describe the RIIC's functions and registers.

26.1 Features

26.1.1 Channels

This LSI has the following number of channels of the I²C bus interface (RIIC).

Table 26.1 Channels of RIIC

Item	Description
Number of channels	4
Name	RIICn (n = 0 to 3)

Table 26.2 Index

Index	Description
n	Throughout this section, the individual channels of the I ² C bus interface are identified by the index "n" (n = 0 to 3); for example, RIICnCR1 for the I ² C bus control register 1.

26.1.2 Register Base Addresses

The base address <RIICn_base> of each RIICn is listed in the following table.

All RIICn register addresses are given as values obtained by adding offsets to the register base address <RIICn_base> for each channel.

Table 26.3 Register Base Address

Channel	Base Address Name	Base Address
RIIC0	<RIIC0_base>	H'0_1005_8000 (AX45MP Address Space)
RIIC1	<RIIC1_base>	H'0_1005_8400 (AX45MP Address Space)
RIIC2	<RIIC2_base>	H'0_1005_8800 (AX45MP Address Space)
RIIC3	<RIIC3_base>	H'0_1005_8C00 (AX45MP Address Space)

26.1.3 External I/O Signals

The following table shows the external I/O signals of the RIIC.

Table 26.4 RIICn Pin Configuration

Channel	Alternative Port Pin Name	Function
RIIC0	RIIC0_SCL	RIIC0 serial clock I/O pin
	RIIC0_SDA	RIIC0 serial data I/O pin
RIIC1	RIIC1_SCL	RIIC1 serial clock I/O pin
	RIIC1_SDA	RIIC1 serial data I/O pin
RIIC2	RIIC2_SCL	RIIC2 serial clock I/O pin
	RIIC2_SDA	RIIC2 serial data I/O pin
RIIC3	RIIC3_SCL	RIIC3 serial clock I/O pin
	RIIC3_SDA	RIIC3 serial data I/O pin

Table 26.5 I²C Bus Interface

Channel Number* ³	Pin Name* ¹	I/O	Function	This LSI
				Output Buffer Type* ²
0	SCL	I/O	SCL: I ² C serial clock input/output pin SDA: I ² C serial data input/output pin	OD
	SDA			
1	SCL			OD
	SDA			
2	SCL			LVTTTL
	SDA			
3	SCL			LVTTTL
	SDA			

Note 1. The actual pin names are RIICnSCL and RIICnSDA.

Note 2. Output buffer type: "OD" is open drain buffer and "LVTTTL" is low level drive only LVTTTL buffer.

Note 3. AC specification is different between channel 0, 1 and channel 2, 3.

26.2 Overview

26.2.1 Functional Overview

Communications format

- I²C bus format or SMBus format
- Master mode or slave mode selectable
- Automatic securing of the various set-up times, hold times, and bus-free times for the transfer rate

Transfer rate

Up to 1 Mbps

SCL clock

For master operation, the duty cycle of the SCL clock is selectable in the following range. $0\% < \text{Duty cycle} < 100\%$.

Issuing and detecting conditions

- Start, restart, and stop conditions are automatically generated.
- Start conditions (including restart conditions) and stop conditions are detected.

Slave address

- Up to three slave-address settings can be made.
- Seven- and ten-bit address formats are supported (along with the use of both at once).
- General call addresses, device ID addresses, and SMBus host addresses are detected.

Acknowledgement

- For transmission, the acknowledge bit is automatically loaded
 - Transfer of the next data for transmission can be automatically suspended on detection of a not-acknowledge bit.
- For reception, the acknowledge bit is automatically transmitted
 - If a wait between the eighth and ninth clock cycles has been selected, software control of the value in the acknowledge field in response to the received value is possible.

Wait function

- In reception, the following periods of waiting can be obtained by holding the clock signal (SCL) at the low level:
 - Waiting between the eighth and ninth clock cycles
 - Waiting between the ninth clock cycle and the first clock cycle of the next transfer (WAIT function)

SDA output delay function

Timing of the output of transmitted data, including the acknowledge bit, can be delayed.

Arbitration

- For multi-master operation
 - Operation to synchronize the SCL (clock) signal in cases of conflict with the SCL signal from another master is possible.
 - When issuing the start condition would create conflict on the bus, loss of arbitration is detected by testing for non-matching between the internal signal for the SDA line and the level on the SDA line.
 - In master operation, loss of arbitration is detected by testing for non-matching between the signal on the SDA line and the internal signal for the SDA line.
- Loss of arbitration due to detection of the start condition while the bus is busy is detectable (to prevent the issuing of double start conditions).
- Loss of arbitration in transfer of a not-acknowledge bit due to the internal signal for the SDA line and the level on the SDA line not matching is detectable.
- Loss of arbitration due to non-matching of internal and line levels for data is detectable in slave transmission.

Timeout function

The internal time-out function is capable of detecting long-interval stop of the SCL (clock signal).

Noise removal

The interface incorporates analog noise filters and digital noise filters for input on the RIICnSCL and RIICnSDA pins, and the width for noise cancellation by the digital noise filters is adjustable by software.

Interrupt sources

- Eight sources:
 - Transmission complete
 - Receive-data-full
 - Transmit-data-empty
 - Detection of a stop condition
 - Detection of a start condition
 - Reception of a NACK
 - Arbitration lost
 - Timeout

Low power consumption function

Module-stop state can be set.

26.2.2 Block Diagram

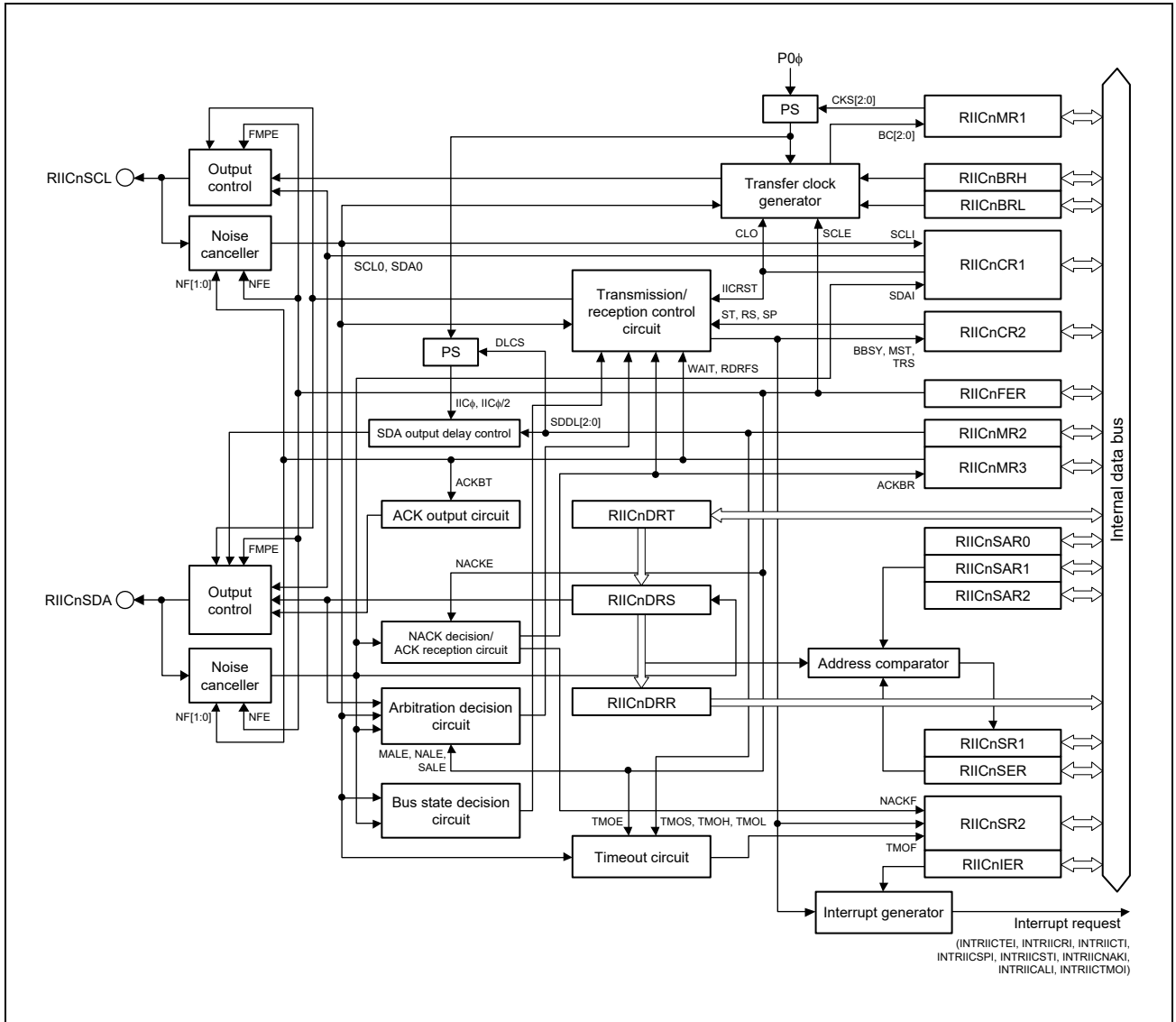

Figure 26.1 Block Diagram of IIC

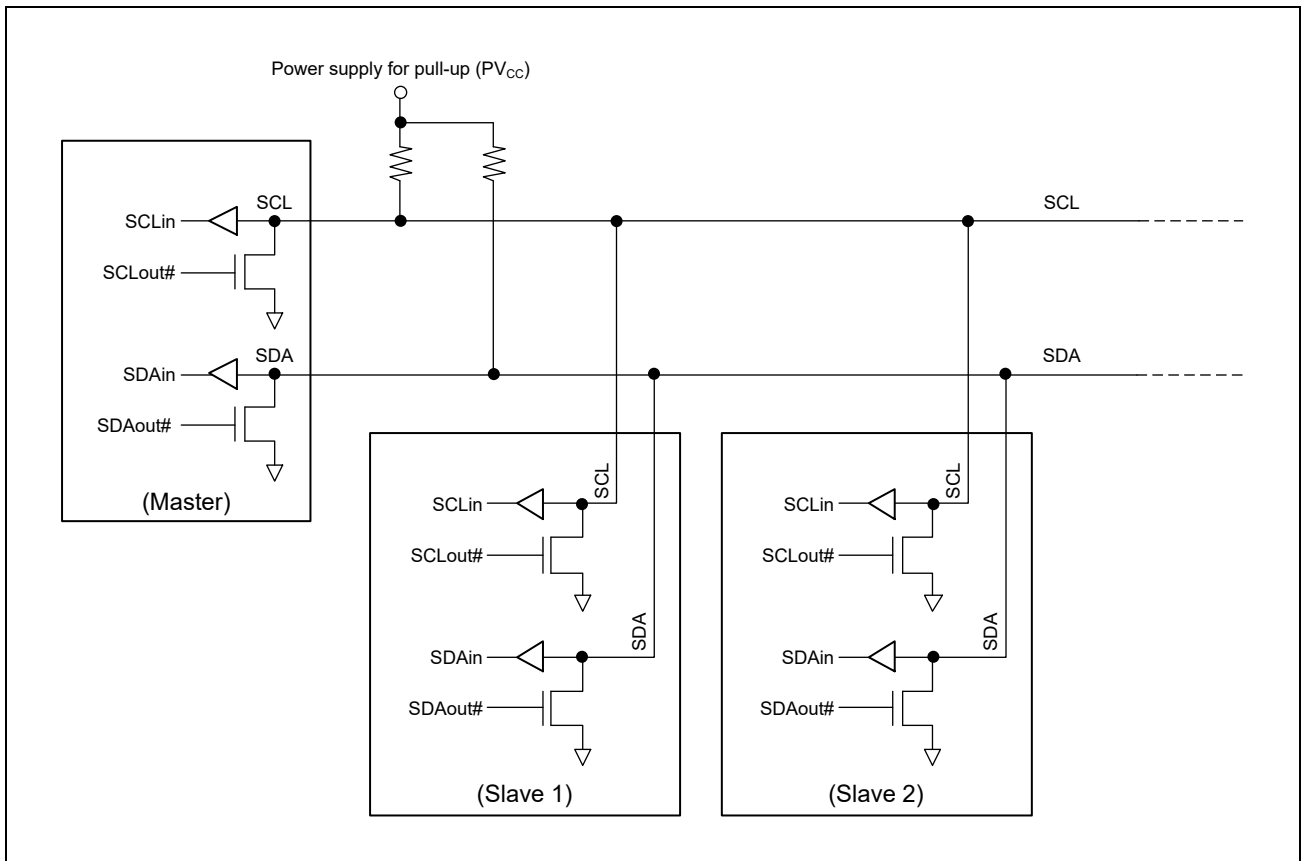

Figure 26.2 Connections to the External Circuit by the I/O Pins (I²C Bus Configuration Example)

RIICnSCL and RIICnSDA are Schmitt input/open-drain output pins for both master and slave operations. Because the output is open drain, an external pull-up resistor is required.

26.3 Registers

Channel	Register Name	Abbreviation	Offset Address	Access Size
RIICn	I ² C bus control register 1	ICCR1	H'00	8, 16, 32
(n = 0 to 3)	I ² C bus control register 2	ICCR2	H'04	8, 16, 32
	I ² C bus mode register 1	ICMR1	H'08	8, 16, 32
	I ² C bus mode register 2	ICMR2	H'0C	8, 16, 32
	I ² C bus mode register 3	ICMR3	H'10	8, 16, 32
	I ² C bus function enable register	ICFER	H'14	8, 16, 32
	I ² C bus status enable register	ICSER	H'18	8, 16, 32
	I ² C bus interrupt enable register	ICIER	H'1C	8, 16, 32
	I ² C bus status register 1	ICSR1	H'20	8, 16, 32
	I ² C bus status register 2	ICSR2	H'24	8, 16, 32
	I ² C slave address register 0	ICSAR0	H'28	8, 16, 32
	I ² C slave address register 1	ICSAR1	H'2C	8, 16, 32
	I ² C slave address register 2	ICSAR2	H'30	8, 16, 32
	I ² C bus bit rate low-level register	ICBRL	H'34	8, 16, 32
	I ² C bus bit rate high-level register	ICBRH	H'38	8, 16, 32
	I ² C bus transmit data register	ICDRT	H'3C	8, 16, 32
	I ² C bus receive data register	ICDRR	H'40	8, 16, 32

26.3.1 RIICnCR1 — I²C Bus Control Register 1

- Access Size:** RIICnCR1 is a 32-bit readable/writable register.
 RIICnCR1L and RIICnCR1H are 16-bit readable/writable registers.
 RIICnCR1LL, RIICnCR1LH, RIICnCR1HL, and RIICnCR1HH are 8-bit readable/writable registers.
- Address(es):** RIICnCR1: <RIICn_base> + H'0000
 RIICnCR1L: <RIICn_base> + H'0000, RIICnCR1H: <RIICn_base> + H'0002
 RIICnCR1LL: <RIICn_base> + H'0000, RIICnCR1LH: <RIICn_base> + H'0001,
 RIICnCR1HL: <RIICn_base> + H'0002, RIICnCR1HH: <RIICn_base> + H'0003
- Initial Value:** H'0000 001F. This register is initialized by any reset.

Bit	31	30	29	28	27	26	25	24	23	22	21	20	19	18	17	16
	—	—	—	—	—	—	—	—	—	—	—	—	—	—	—	—
Initial Value	0	0	0	0	0	0	0	0	0	0	0	0	0	0	0	0
R/W	R	R	R	R	R	R	R	R	R	R	R	R	R	R	R	R
Bit	15	14	13	12	11	10	9	8	7	6	5	4	3	2	1	0
	—	—	—	—	—	—	—	—	ICE	IICRST	CLO	SOWP	SCLO	SDAO	SCLI	SDAI
Initial Value	0	0	0	0	0	0	0	0	0	0	0	1	1	1	1	1
R/W	R	R	R	R	R	R	R	R	R/W	R/W	R/W	R/W	R/W	R/W	R	R

Bit	Bit Name	Initial Value	R/W	Description
31 to 8	—	All 0	R	Reserved These bits are read as 0. The write value should be 0.
7	ICE	0	R/W	I ² C Bus Interface Enable 0: Output to the RIICnSCL and RIICnSDA pins is disabled. (Input to the RIICnSCL and RIICnSDA pins is enabled.) 1: Enabled (RIICnSCL and RIICnSDA pins are in the driving state) (An RIIC reset or an internal reset is selected according to the combination of this bit and IICRST bit settings.)
6	IICRST	0	R/W	I ² C Bus Interface Internal Reset 0: Clears the RIIC reset or internal reset. 1: Initiates the RIIC reset or internal reset. (Clears the bit counter and the SCL/SDA output latch)
5	CLO	0	R/W	Extra SCL Clock Cycle Output 0: Does not output an extra SCL clock cycle (default). 1: Outputs an extra SCL clock cycle. (The CLO bit is cleared automatically after one clock cycle is output.)
4	SOWP*2	1	R/W	SCLO/SDAO Write Protect 0: Allows the SCLO and SDAO bits to be rewritten. (This bit is read as 1.)
3	SCLO*1,*2	1	R/W	SCL Output Control • Read: 0: RIICnSCL pin output is at a low level. 1: RIICnSCL pin is in a high-impedance state. • Write: 0: Changes the RIICnSCL pin output to a low level. 1: Changes the RIICnSCL pin in a high-impedance state. (High level output is achieved through an external pull-up resistor.)

Bit	Bit Name	Initial Value	R/W	Description
2	SDAO*1,*2	1	R/W	SDA Output Control <ul style="list-style-type: none"> • Read: <ul style="list-style-type: none"> 0: RIICnSDA pin output is at a low level. 1: RIICnSDA pin is in a high-impedance state. • Write: <ul style="list-style-type: none"> 0: Changes the RIICnSDA pin output to a low level. 1: Changes the RIICnSDA pin in a high-impedance state. (High level output is achieved through an external pull-up resistor.)
1	SCLI	1	R	SCL Bus Input Monitor <ul style="list-style-type: none"> 0: RIICnSCL pin input is at a low level. 1: RIICnSCL pin input is at a high level.
0	SDAI	1	R	SDA Bus Input Monitor <ul style="list-style-type: none"> 0: RIICnSDA pin input is at a low level. 1: RIICnSDA pin input is at a high level.

Note 1. Do not write to these bits during communication. Changing a value during communication may cause a transmission or reception failure or an AL error.

Note 2. To change the SDAO and SCLO bits, set the SOWP bit to 0 at the same timing to set the SDAO and SCLO bits to 0.

CLO Bit (Extra SCL Clock Cycle Output)

This bit is used to output an extra SCL clock cycle for debugging or error processing.

Normally, set the bit to 0. Setting the bit to 1 in a normal communication state causes a communication error. For details on this function, see **Section 26.13.2, Extra SCL Clock Cycle Output Function**.

IICRST Bit (I²C Bus Interface Internal Reset)

This bit is used to reset the internal states of the RIIC. Setting this bit to 1 initiates an RIIC reset or internal reset.

Whether an RIIC reset or internal reset is initiated is determined according to the combination with the ICE bit. **Table 26.6** lists the resets of the RIIC.

The RIIC reset resets all registers including the RIICnCR2.BBSY flag (except ICE and IICRST) and internal states of the RIIC, and the internal reset resets the bit counter (RIICnMR1.BC[2:0] bits), the I²C bus shift register (RIICnDRS), and the I²C bus status registers (RIICnSR1 and RIICnSR2) as well as the internal states of the RIIC. For the reset conditions for each register, see **Section 26.15, Reset Function of RIIC**.

An internal reset initiated with the IICRST bit set to 1 during operation (with the ICE bit set to 1) resets the internal states of the RIIC without initializing the port settings and the control and setting registers of the RIIC when the bus or RIIC hangs up due to a communication error.

If the RIIC hangs up in a low level output state, resetting the internal states cancels the low level output state and releases the bus with the RIICnSCL pin and RIICnSDA pin at a high impedance.

CAUTION

If an internal reset is initiated using the IICRST bit for a bus hang-up occurred during communication with the master device in slave mode, the states may become different between the slave device and the master device (due to the difference in the bit counter information). For this reason, do not initiate an internal reset in slave mode, but initiate restoration processing from the master device. If an internal reset is necessary because the RIIC hangs up with the SCL line in a low level output state in slave mode, initiate an internal reset and then issue a restart condition from the master device or resume communication from the start condition issuance after issuing a stop condition. If communication is restarted by initiating a reset solely in the slave device without issuing a start condition or restart condition from the master device, synchronization will be lost because the master and slave devices operate asynchronously.

Table 26.6 RIIC Resets

IICRST	ICE	State	Specifications
1	0	RIIC reset	Resets all registers (except ICE and IICRST) and internal states of the RIIC.
	1	Internal reset	Reset the RIICnMR1.BC[2:0] bits, and the RIICnSR1, RIICnSR2, RIICnDRS registers and the internal states of the RIIC.

ICE Bit (I²C Bus Interface Enable)

The ICE bit selects driving or non-driving of the RIICnSCL and RIICnSDA pins. Moreover, this bit can perform two types of reset in combination with the IICRST bit. For the types of reset, see **Table 26.6**.

Set the ICE bit to 1 when using RIIC. Setting the ICE bit to 1 selects driving of the RIICnSCL and RIICnSDA pins. Set the ICE bit to 0 when RIIC is not to be used. Clearing the ICE bit to 0 disables output from the RIICnSCL and RIICnSDA pins.

26.3.2 RIICnCR2 — I²C Bus Control Register 2

Access Size: RIICnCR2 is a 32-bit readable/writable register.
 RIICnCR2L and RIICnCR2H are 16-bit readable/writable registers.
 RIICnCR2LL, RIICnCR2LH, RIICnCR2HL, and RIICnCR2HH are 8-bit readable/writable registers.

Address(es): RIICnCR2: <RIICn_base> + H'0004
 RIICnCR2L: <RIICn_base> + H'0004, RIICnCR2H: <RIICn_base> + H'0006
 RIICnCR2LL: <RIICn_base> + H'0004, RIICnCR2LH: <RIICn_base> + H'0005,
 RIICnCR2HL: <RIICn_base> + H'0006, RIICnCR2HH: <RIICn_base> + H'0007

Initial Value: H'0000 0000 This register is initialized by any reset.

Bit	31	30	29	28	27	26	25	24	23	22	21	20	19	18	17	16
	—	—	—	—	—	—	—	—	—	—	—	—	—	—	—	—
Initial Value	0	0	0	0	0	0	0	0	0	0	0	0	0	0	0	0
R/W	R	R	R	R	R	R	R	R	R	R	R	R	R	R	R	R
Bit	15	14	13	12	11	10	9	8	7	6	5	4	3	2	1	0
	—	—	—	—	—	—	—	—	BBSY	MST	TRS	—	SP	RS	ST	—
Initial Value	0	0	0	0	0	0	0	0	0	0	0	0	0	0	0	0
R/W	R	R	R	R	R	R	R	R	R	R	R	R	R/W	R/W	R/W	R

Bit	Bit Name	Initial Value	R/W	Description
31 to 8	—	All 0	R	Reserved These bits are read as 0. The write value should be 0.
7	BBSY	0	R	Bus Busy Detection Flag 0: The I ² C bus is released (bus free state). 1: The I ² C bus is occupied (bus busy state or in the bus free state).
6	MST	0	R	Master/Slave Mode 0: Slave mode 1: Transmit mode
5	TRS	0	R	Transmit/Receive Mode 0: Receive mode 1: Transmit mode
4	—	0	R	Reserved These bits are read as 0. The write value should be 0.
3	SP	0	R/W	Stop Condition Issuance Request 0: Does not request to issue a stop condition. 1: Requests to issue a stop condition.
2	RS	0	R/W	Restart Condition Issuance Request 0: Does not request to issue a restart condition. 1: Requests to issue a restart condition.
1	ST	0	R/W	Start Condition Issuance Request 0: Does not request to issue a start condition. 1: Requests to issue a start condition.
0	—	0	R	Reserved These bits are read as 0. The write value should be 0.

ST Bit (Start Condition Issuance Request)

This bit is used to request transition to master mode and issuance of a start condition.

When this bit is set to 1 to request to issue a start condition, a start condition is issued when the BBSY flag is set to 0 (bus free).

For details on the start condition issuance, see **Section 26.12, Start Condition/Restart Condition/Stop Condition Issuing Function**.

[Setting condition]

When 1 is written to the ST bit

[Clearing conditions]

- When 0 is written to the ST bit
- When a start condition has been issued
- When the RIICnSR2.AL (arbitration-lost) flag is set to 1
- When 1 is written to the RIICnCR1.IICRST bit to apply an RIIC reset or an internal reset

CAUTION

Set the ST bit to 1 (start condition issuance request) when the BBSY flag is set to 0 (bus free).

Note that arbitration may be lost if the ST bit is set to 1 (start condition issuance request) when the BBSY flag is set to 1 (bus busy).

RS Bit (Restart Condition Issuance Request)

This bit is used to request that a restart condition be issued in master mode.

When this bit is set to 1 to request to issue a restart condition, a restart condition is issued when the BBSY flag is set to 1 (bus busy) and the MST bit is set to 1 (master mode).

For details on the restart condition issuance, see **Section 26.12, Start Condition/Restart Condition/Stop Condition Issuing Function**.

[Setting condition]

When 1 is written to the RS bit with the RIICnCR2.BBSY flag set to 1

[Clearing conditions]

- When 0 is written to the RS bit
- When a restart condition has been issued or a start condition is detected
- When a stop condition is detected
- When the RIICnCR2.AL (arbitration-lost) flag is set to 1
- When 1 is written to the RIICnCR1.IICRST bit to apply an RIIC reset or an internal reset

CAUTIONS

1. Do not set the RS bit to 1 while issuing a stop condition.
2. It is commended to issue a restart condition in master transmit mode. If the RS bit is set to 1 (restart condition issuance request) in mode other than master mode, the restart condition is not issued in this mode but the restart condition issuance request bit remains set. If the operating mode changes to master mode with the bit not being cleared, the restart condition may be issued.

SP Bit (Stop Condition Issuance Request)

This bit is used to request that a stop condition be issued in master mode.

When this bit is set to 1 to request to issue a stop condition, a stop condition is issued when the BBSY flag is set to 1 (bus busy) and the MST bit is set to 1 (master mode).

For details on the stop condition issuance, see **Section 26.12, Start Condition/Restart Condition/Stop Condition Issuing Function**.

[Setting condition]

When 1 is written to the SP bit with both the RIICnCR2.BBSY flag and the RIICnCR2.MST bit set to 1

[Clearing conditions]

- When 0 is written to the SP bit
- When a stop condition has been issued or a stop condition is detected
- When the RIICnSR2.AL (arbitration-lost) flag is set to 1
- When a start condition and a restart condition are detected
- When 1 is written to the RIICnCR1.IICRST bit to apply an RIIC reset or an internal reset

CAUTIONS

1. Writing to the SP bit is not possible while the setting of the BBSY flag is 0 (bus free).
2. Do not set the SP bit to 1 while a restart condition is being issued.

TRS Bit (Transmit/Receive Mode)

This bit indicates transmit or receive mode.

The RIIC is in receive mode when the TRS bit is set to 0 and is in transmit mode when the bit is set to 1. Combination of this bit and the MST bit indicates the operating mode of the RIIC.

The value of the TRS bit is automatically changed to the value for transmission mode or reception mode by detection or issuing of a start condition, setting or clearing of the R/W# bit, etc.

[Setting conditions]

- When a start condition is issued normally according to the start condition issuance request (when a start condition is detected with the ST bit set to 1)
- When the R/W# bit added to the slave address is set to 0 in master mode
- When the address received in slave mode matches the address enabled in RIICnSER, with the R/W# bit set to 1

[Clearing conditions]

- When a stop condition is detected
- The RIICnSR2.AL (arbitration-lost) flag being set to 1
- In master mode, reception of a slave address to which an R/W# bit with the value 1 is appended
- In slave mode, a match between the received address and the address enabled in RIICnSER when the value of the received R/W# bit is 0 (including cases where the received address is the general call address)
- In slave transmit mode, a restart condition is detected (a restart condition is detected with RIICnCR2.BBSY = 1 and RIICnCR2.MST = 0)
- When 1 is written to the RIICnCR1.IICRST bit to apply an RIIC reset or an internal reset

MST Bit (Master/Slave Mode)

This bit indicates master or slave mode.

The RIIC is in slave mode when the MST bit is set to 0 and is in master mode when the bit is set to 1. Combination of this bit and the TRS bit indicates the operating mode of the RIIC.

The value of the MST bit is automatically changed to the value for master mode or slave mode by detection or issuing of a start condition, etc.

[Setting conditions]

- When a start condition is issued normally according to the start condition issuance request (when a start condition is detected with the ST bit set to 1)

[Clearing conditions]

- When a stop condition is detected
- When the RIICnSR2.AL (arbitration-lost) flag is set to 1
- When 1 is written to the RIICnCR1.IICRST bit to apply an RIIC reset or an internal reset

BBSY Flag (Bus Busy Detection)

The BBSY flag indicates whether the I²C bus is occupied (bus busy) or released (bus free).

This bit is set to 1 when the SDA line changes from high to low under the condition of SCL = high, assuming that a start condition has been issued.

When the SDA line changes from low to high under the condition of SCL = high, this bit is cleared to 0 after the bus free time (specified in RIICnBRL) start condition is not detected, assuming that a stop condition has been issued.

[Setting condition]

- When a start condition is detected

[Clearing conditions]

- When the bus free time (specified in RIICnBRL) start condition is not detected after detecting a stop condition
- When 1 is written to the RIICnCR1.IICRST bit with the RIICnCR1.ICE bit set to 0 (RIIC reset)

26.3.3 RIICnMR1 — I²C Bus Mode Register 1

- Access Size:** RIICnMR1 is a 32-bit readable/writable register.
 RIICnMR1L and RIICnMR1H are 16-bit readable/writable registers.
 RIICnMR1LL, RIICnMR1LH, RIICnMR1HL, and RIICnMR1HH are 8-bit readable/writable registers.
- Address(es):** RIICnMR1: <RIICn_base> + H'0008
 RIICnMR1L: <RIICn_base> + H'0008, RIICnMR1H: <RIICn_base> + H'000A
 RIICnMR1LL: <RIICn_base> + H'0008, RIICnMR1LH: <RIICn_base> + H'0009,
 RIICnMR1HL: <RIICn_base> + H'000A, RIICnMR1HH: <RIICn_base> + H'000B
- Initial Value:** H'0000 0008 This register is initialized by any reset.

Bit	31	30	29	28	27	26	25	24	23	22	21	20	19	18	17	16
	—	—	—	—	—	—	—	—	—	—	—	—	—	—	—	—
Initial Value	0	0	0	0	0	0	0	0	0	0	0	0	0	0	0	0
R/W	R	R	R	R	R	R	R	R	R	R	R	R	R	R	R	R
Bit	15	14	13	12	11	10	9	8	7	6	5	4	3	2	1	0
	—	—	—	—	—	—	—	—	—	CKS[2:0]		BCWP		BC[2:0]		
Initial Value	0	0	0	0	0	0	0	0	0	0	0	0	1	0	0	0
R/W	R	R	R	R	R	R	R	R	R	R/W	R/W	R/W	R/W	R/W	R/W	R/W

Bit	Bit Name	Initial Value	R/W	Description																											
31 to 7	—	All 0	R	Reserved These bits are read as 0. The write value should be 0.																											
6 to 4	CKS[2:0]	All 0	R/W	Internal Reference Clock (IIC ϕ) Selection <table border="0"> <tr> <td>b6</td> <td>b4</td> <td></td> </tr> <tr> <td>0</td> <td>0</td> <td>0: IICϕ = P0ϕ/1</td> </tr> <tr> <td>0</td> <td>0</td> <td>1: IICϕ = P0ϕ/2</td> </tr> <tr> <td>0</td> <td>1</td> <td>0: IICϕ = P0ϕ/4</td> </tr> <tr> <td>0</td> <td>1</td> <td>1: IICϕ = P0ϕ/8</td> </tr> <tr> <td>1</td> <td>0</td> <td>0: IICϕ = P0ϕ/16</td> </tr> <tr> <td>1</td> <td>0</td> <td>1: IICϕ = P0ϕ/32</td> </tr> <tr> <td>1</td> <td>1</td> <td>0: IICϕ = P0ϕ/64</td> </tr> <tr> <td>1</td> <td>1</td> <td>1: IICϕ = P0ϕ/128</td> </tr> </table>	b6	b4		0	0	0: IIC ϕ = P0 ϕ /1	0	0	1: IIC ϕ = P0 ϕ /2	0	1	0: IIC ϕ = P0 ϕ /4	0	1	1: IIC ϕ = P0 ϕ /8	1	0	0: IIC ϕ = P0 ϕ /16	1	0	1: IIC ϕ = P0 ϕ /32	1	1	0: IIC ϕ = P0 ϕ /64	1	1	1: IIC ϕ = P0 ϕ /128
b6	b4																														
0	0	0: IIC ϕ = P0 ϕ /1																													
0	0	1: IIC ϕ = P0 ϕ /2																													
0	1	0: IIC ϕ = P0 ϕ /4																													
0	1	1: IIC ϕ = P0 ϕ /8																													
1	0	0: IIC ϕ = P0 ϕ /16																													
1	0	1: IIC ϕ = P0 ϕ /32																													
1	1	0: IIC ϕ = P0 ϕ /64																													
1	1	1: IIC ϕ = P0 ϕ /128																													
3	BCWP*1	1	R/W	BC Write Protect 0: Enables a value to be written in the BC[2:0] bits. (This bit is read as 1.)																											
2 to 0	BC[2:0]	All 0	R/W	Bit Counter <table border="0"> <tr> <td>b2</td> <td>b0</td> <td></td> </tr> <tr> <td>0</td> <td>0</td> <td>0: 9 bits</td> </tr> <tr> <td>0</td> <td>0</td> <td>1: 2 bits</td> </tr> <tr> <td>0</td> <td>1</td> <td>0: 3 bits</td> </tr> <tr> <td>0</td> <td>1</td> <td>1: 4 bits</td> </tr> <tr> <td>1</td> <td>0</td> <td>0: 5 bits</td> </tr> <tr> <td>1</td> <td>0</td> <td>1: 6 bits</td> </tr> <tr> <td>1</td> <td>1</td> <td>0: 7 bits</td> </tr> <tr> <td>1</td> <td>1</td> <td>1: 8 bits</td> </tr> </table>	b2	b0		0	0	0: 9 bits	0	0	1: 2 bits	0	1	0: 3 bits	0	1	1: 4 bits	1	0	0: 5 bits	1	0	1: 6 bits	1	1	0: 7 bits	1	1	1: 8 bits
b2	b0																														
0	0	0: 9 bits																													
0	0	1: 2 bits																													
0	1	0: 3 bits																													
0	1	1: 4 bits																													
1	0	0: 5 bits																													
1	0	1: 6 bits																													
1	1	0: 7 bits																													
1	1	1: 8 bits																													

Note 1. When rewriting the BC[2:0] bits, write 0 to the BCWP bit simultaneously.

BC[2:0] Bits (Bit Counter)

These bits function as a counter that indicates the number of bits remaining to be transferred at the detection of a rising edge on the SCL line. Although these bits are writable and readable, it is not necessary to access these bits under normal conditions.

To write to these bits, specify the number of bits to be transferred plus one (data is transferred with an additional acknowledge bit) between transferred frames when the SCL line is at a low level.

The values of the BC[2:0] bits return to 000b at the end of a data transfer including the acknowledge bit or when a start condition including a restart condition is detected.

26.3.4 RIICnMR2 — I²C Bus Mode Register 2

- Access Size:** RIICnMR2 is a 32-bit readable/writable register.
 RIICnMR2L and RIICnMR2H are 16-bit readable/writable registers.
 RIICnMR2LL, RIICnMR2LH, RIICnMR2HL, and RIICnMR2HH are 8-bit readable/writable registers.
- Address(es):** RIICnMR2: <RIICn_base> + H'000C
 RIICnMR2L: <RIICn_base> + H'000C, RIICnMR2H: <RIICn_base> + H'000E
 RIICnMR2LL: <RIICn_base> + H'000C, RIICnMR2LH: <RIICn_base> + H'000D,
 RIICnMR2HL: <RIICn_base> + H'000E, RIICnMR2HH: <RIICn_base> + H'000F
- Initial Value:** H'0000 0006 This register is initialized by any reset.

Bit	31	30	29	28	27	26	25	24	23	22	21	20	19	18	17	16
	—	—	—	—	—	—	—	—	—	—	—	—	—	—	—	—
Initial Value	0	0	0	0	0	0	0	0	0	0	0	0	0	0	0	0
R/W	R	R	R	R	R	R	R	R	R	R	R	R	R	R	R	R
Bit	15	14	13	12	11	10	9	8	7	6	5	4	3	2	1	0
	—	—	—	—	—	—	—	—	DLCS	SDDL[2:0]		—	—	TMOH	TMOL	TMOS
Initial Value	0	0	0	0	0	0	0	0	0	0	0	0	0	1	1	0
R/W	R	R	R	R	R	R	R	R	R/W	R/W	R/W	R/W	R	R/W	R/W	R/W

Bit	Bit Name	Initial Value	R/W	Description																																																						
31 to 8	—	All 0	R	Reserved These bits are read as 0. The write value should be 0.																																																						
7	DLCS	0	R/W	SDA Output Delay Clock Source Selection 0: The internal reference clock (IIC ϕ) is selected as the clock source of the SDA output delay counter. 1: The internal reference clock divided by 2 (IIC ϕ /2) is selected as the clock source of the SDA output delay counter.*1																																																						
6 to 4	SDDL[2:0]	All 0	R/W	SDA Output Delay Counter • When RIICnMR2.DLCS = 0 (IIC ϕ) <table border="0"> <tr> <td>b6</td> <td>b4</td> <td></td> </tr> <tr> <td>0</td> <td>0</td> <td>0: No output delay</td> </tr> <tr> <td>0</td> <td>0</td> <td>1: 1 IICϕ cycle</td> </tr> <tr> <td>0</td> <td>1</td> <td>0: 2 IICϕ cycles</td> </tr> <tr> <td>0</td> <td>1</td> <td>1: 3 IICϕ cycles</td> </tr> <tr> <td>1</td> <td>0</td> <td>0: 4 IICϕ cycles</td> </tr> <tr> <td>1</td> <td>0</td> <td>1: 5 IICϕ cycles</td> </tr> <tr> <td>1</td> <td>1</td> <td>0: 6 IICϕ cycles</td> </tr> <tr> <td>1</td> <td>1</td> <td>1: 7 IICϕ cycles</td> </tr> </table> • When RIICnMR2.DLCS = 1 (IIC ϕ /2) <table border="0"> <tr> <td>b6</td> <td>b4</td> <td></td> </tr> <tr> <td>0</td> <td>0</td> <td>0: No output delay</td> </tr> <tr> <td>0</td> <td>0</td> <td>1: 1 or 2 IICϕ cycles</td> </tr> <tr> <td>0</td> <td>1</td> <td>0: 3 or 4 IICϕ cycles</td> </tr> <tr> <td>0</td> <td>1</td> <td>1: 5 or 6 IICϕ cycles</td> </tr> <tr> <td>1</td> <td>0</td> <td>0: 7 or 8 IICϕ cycles</td> </tr> <tr> <td>1</td> <td>0</td> <td>1: 9 or 10 IICϕ cycles</td> </tr> <tr> <td>1</td> <td>1</td> <td>0: 11 or 12 IICϕ cycles</td> </tr> <tr> <td>1</td> <td>1</td> <td>1: 13 or 14 IICϕ cycles</td> </tr> </table>	b6	b4		0	0	0: No output delay	0	0	1: 1 IIC ϕ cycle	0	1	0: 2 IIC ϕ cycles	0	1	1: 3 IIC ϕ cycles	1	0	0: 4 IIC ϕ cycles	1	0	1: 5 IIC ϕ cycles	1	1	0: 6 IIC ϕ cycles	1	1	1: 7 IIC ϕ cycles	b6	b4		0	0	0: No output delay	0	0	1: 1 or 2 IIC ϕ cycles	0	1	0: 3 or 4 IIC ϕ cycles	0	1	1: 5 or 6 IIC ϕ cycles	1	0	0: 7 or 8 IIC ϕ cycles	1	0	1: 9 or 10 IIC ϕ cycles	1	1	0: 11 or 12 IIC ϕ cycles	1	1	1: 13 or 14 IIC ϕ cycles
b6	b4																																																									
0	0	0: No output delay																																																								
0	0	1: 1 IIC ϕ cycle																																																								
0	1	0: 2 IIC ϕ cycles																																																								
0	1	1: 3 IIC ϕ cycles																																																								
1	0	0: 4 IIC ϕ cycles																																																								
1	0	1: 5 IIC ϕ cycles																																																								
1	1	0: 6 IIC ϕ cycles																																																								
1	1	1: 7 IIC ϕ cycles																																																								
b6	b4																																																									
0	0	0: No output delay																																																								
0	0	1: 1 or 2 IIC ϕ cycles																																																								
0	1	0: 3 or 4 IIC ϕ cycles																																																								
0	1	1: 5 or 6 IIC ϕ cycles																																																								
1	0	0: 7 or 8 IIC ϕ cycles																																																								
1	0	1: 9 or 10 IIC ϕ cycles																																																								
1	1	0: 11 or 12 IIC ϕ cycles																																																								
1	1	1: 13 or 14 IIC ϕ cycles																																																								
3	—	0	R	Reserved These bits are read as 0. The write value should be 0.																																																						

Bit	Bit Name	Initial Value	R/W	Description
2	TMOH	1	R/W	Timeout H Count Control 0: Count is disabled while the SCL line is at a high level. 1: Count is enabled while the SCL line is at a high level.
1	TMOL	1	R/W	Timeout L Count Control 0: Count is disabled while the SCL line is at a low level. 1: Count is enabled while the SCL line is at a low level.
0	TMOS	0	R/W	Timeout Detection Time Selection 0: Long mode is selected. 1: Short mode is selected.

Note 1. The setting DLCS = 1 (IIC ϕ /2) only becomes valid when SCL is at the low level. When SCL is at the high level, the setting DLCS = 1 becomes invalid and the clock source becomes the internal reference clock (IIC ϕ).

TMOS Bit (Timeout Detection Time Selection)

This bit is used to select long mode or short mode for the timeout detection time when the timeout function is enabled (RIICnFER.TMOE bit = 1). When this bit is set to 0, long mode is selected. When this bit is set to 1, short mode is selected. In long mode, the timeout detection internal counter functions as a 16 bit-counter. In short mode, the counter functions as a 14 bit-counter. While the SCL line is in the state that enables this counter as specified by bits TMOH and TMOL, the counter counts up in synchronization with the internal reference clock (IIC ϕ) as a count source.

For details on the timeout function, see **Section 26.13.1, Timeout Function**.

TMOL Bit (Timeout L Count Control)

This bit is used to enable or disable the internal counter of the timeout function to count up while the SCL line is held low when the timeout function is enabled (RIICnFER.TMOE bit = 1).

TMOH Bit (Timeout H Count Control)

This bit is used to enable or disable the internal counter of the timeout function to count up while the SCL line is held high when the timeout function is enabled (RIICnFER.TMOE bit = 1).

SDDL[2:0] Bits (SDA Output Delay Setup Counter)

The SDA output can be delayed by the SDDL[2:0] setting. This counter works with the clock source selected by the DLCS bit. The setting of this function can be used for all types of SDA output, including the transmission of the acknowledge bit.

For details on this function, see **Section 26.7, Facility for Delaying SDA Output**.

CAUTION

Set the SDA output delay time to meet the I²C bus standard (within the data enable time/acknowledge enable time*¹) or the SMBus standard (within the data hold time: 300 [ns] or more, and SCL-clock low-level period - the data setup time: 250 [ns]). Note that, if a value outside the standard is set, communication with communication devices may malfunction or it may seemingly become a start condition or stop condition depending on the bus state.

Note 1. Data enable time/acknowledge enable time
 3,450 [ns] (0 to 100 [kbps]: standard mode (Sm))
 900 [ns] (0 to 400 [kbps]: fast mode (Fm))
 450 [ns] (0 to 1 [Mbps]: fast mode plus (Fm+))

26.3.5 RIICnMR3 — I²C Bus Mode Register 3

- Access Size:** RIICnMR3 is a 32-bit readable/writable register.
 RIICnMR3L and RIICnMR3H are 16-bit readable/writable registers.
 RIICnMR3LL, RIICnMR3LH, RIICnMR3HL, and RIICnMR3HH are 8-bit readable/writable registers.
- Address(es):** RIICnMR3: <RIICn_base> + H'0010
 RIICnMR3L: <RIICn_base> + H'0010, RIICnMR3H: <RIICn_base> + H'0012
 RIICnMR3LL: <RIICn_base> + H'0010, RIICnMR3LH: <RIICn_base> + H'0011,
 RIICnMR3HL: <RIICn_base> + H'0012, RIICnMR3HH: <RIICn_base> + H'0013
- Initial Value:** H'0000 0000 This register is initialized by any reset.

Bit	31	30	29	28	27	26	25	24	23	22	21	20	19	18	17	16
	—	—	—	—	—	—	—	—	—	—	—	—	—	—	—	—
Initial Value	0	0	0	0	0	0	0	0	0	0	0	0	0	0	0	0
R/W	R	R	R	R	R	R	R	R	R	R	R	R	R	R	R	R
Bit	15	14	13	12	11	10	9	8	7	6	5	4	3	2	1	0
	—	—	—	—	—	—	—	—	SMBE	WAIT	RDRFS	ACKWP	ACKBT	ACKBR	NF[1:0]	
Initial Value	0	0	0	0	0	0	0	0	0	0	0	0	0	0	0	0
R/W	R	R	R	R	R	R	R	R	R/W	R/W	R/W	W	R/W	R	R/W	R/W

Bit	Bit Name	Initial Value	R/W	Description
31 to 8	—	All 0	R	Reserved These bits are read as 0. The write value should be 0.
7	SMBE	0	R/W	SMBus/I ² C Bus Selection 0: I ² C bus is selected. 1: SMBus is selected.
6	WAIT* ²	0	R/W	WAIT 0: No WAIT (The period between ninth clock cycle and first clock cycle is not held low.) 1: WAIT (The period between ninth clock cycle and first clock cycle is held low.) Low-hold is released by reading RIICnDRR.
5	RDRFS* ²	0	R/W	RDRF Flag Set Timing Selection 0: The RDRF flag is set at the rising edge of the ninth SCL clock cycle. (The SCL line is not held low at the falling edge of the eighth clock cycle.) 1: The RDRF flag is set at the rising edge of the eighth SCL clock cycle. (The SCL line is held low at the falling edge of the eighth clock cycle.) Low-hold is released by writing a value to the ACKBT bit.
4	ACKWP* ¹	0	W	ACKBT Write Protect 0: Modification of the ACKBT bit is disabled. 1: Modification of the ACKBT bit is enabled.
3	ACKBT* ¹	0	R/W	Transmit Acknowledge 0: A 0 is sent as the acknowledge bit (ACK transmission). 1: A 1 is sent as the acknowledge bit (NACK transmission).
2	ACKBR	0	R	Receive Acknowledge 0: A 0 is received as the acknowledge bit (ACK reception). 1: A 1 is received as the acknowledge bit (NACK reception).

Bit	Bit Name	Initial Value	R/W	Description
1, 0	NF[1:0]	All 0	R/W	Noise Filter Stage Selection <div style="margin-left: 20px;"> b1 b0 0 0: Noise of up to one IICϕ cycle is filtered out (single-stage filter). 0 1: Noise of up to two IICϕ cycles is filtered out (2-stage filter). 1 0: Noise of up to three IICϕ cycles is filtered out (3-stage filter). 1 1: Noise of up to four IICϕ cycles is filtered out (4-stage filter). </div>

Note 1. If it is attempted to write 1 to both ACKWP and ACKBT bits, the ACKBT bit cannot be set to 1.

Note 2. The WAIT and RDRFS bits are valid only in receive mode (invalid in transmit mode).

NF[1:0] Bits (Noise Filter Stage Selection)

These bits are used to select the width of noise that can be removed from the signals input to RIICnSCL or RIICnSDA pin.

ACKBR Bit (Receive Acknowledge)

This bit is used to store the acknowledge bit information received from the receive device in transmit mode.

[Setting condition]

When 1 is received as the acknowledge bit with the RIICnCR2.TRS bit set to 1

[Clearing conditions]

- When 0 is received as the acknowledge bit with the RIICnCR2.TRS bit set to 1
- When 1 is written to the RIICnCR1.IICRST bit while the RIICnCR1.ICE bit is 0 (RIIC reset)

ACKBT Bit (Transmit Acknowledge)

This bit is used to set the bit to be sent at the acknowledge timing in receive mode.

[Setting condition]

When 1 is written to this bit with the ACKWP bit set to 1

[Clearing conditions]

- When 0 is written to this bit with the ACKWP bit set to 1
- When stop condition issuance is detected
- When 1 is written to the RIICnCR1.IICRST bit while the RIICnCR1.ICE bit is 0 (RIIC reset)

CAUTION

The ACKBT bit must be written to while the ACKWP bit is 1. If the ACKBT bit is written to with the ACKWP bit cleared to 0, writing to the ACKBT bit is disabled.

ACKWP Bit (ACKBT Write Protect)

This bit is used to control the modification of the ACKBT bit.

RDRFS Bit (RDRF Flag Set Timing Selection)

This bit is used to select the RDRF flag set timing in receive mode and also to select whether to hold the SCL line low at the falling edge of the eighth SCL clock cycle.

When the RDRFS bit is 0, the SCL line is not held low at the falling edge of the eighth SCL clock cycle, and the RDRF flag is set to 1 at the rising edge of the ninth SCL clock cycle.

When the RDRFS bit is 1, the RDRF flag is set to 1 at the rising edge of the eighth SCL clock cycle and the SCL line is held low at the falling edge of the eighth SCL clock cycle. The low-hold of the SCL line is released by writing a value to the ACKBT bit.

After data is received with this setting, the SCL line is automatically held low before the acknowledge bit is sent. This enables processing to send ACK (ACKBT = 0) or NACK (ACKBT = 1) according to receive data.

WAIT Bit (WAIT)

This bit is used to control whether to hold the period between the ninth SCL clock cycle and the first SCL clock cycle low until the receive data buffer (RIICnDRR) is completely read each time single-byte data is received in receive mode. When the WAIT bit is 0, the receive operation is continued without holding the period between the ninth and the first SCL clock cycle low. When both the RDRFS and WAIT bits are 0, continuous receive operation is enabled with the double buffer.

When the WAIT bit is 1, the SCL line is held low from the falling edge of the ninth clock cycle until the RIICnDRR value is read each time single-byte data is received. This enables receive operation in byte units.

CAUTION

When the value of the WAIT bit is to be read, be sure to read the RIICnDRR beforehand.

SMBE Bit (SMBus Select)

Setting this bit to 1 enables the RIICnSER.HOAE bit.

26.3.6 RIICnFER — I²C Bus Function Enable Register

Access Size: RIICnFER is a 32-bit readable/writable register.
 RIICnFERL and RIICnFERH are 16-bit readable/writable registers.
 RIICnFERLL, RIICnFERLH, RIICnFERHL, and RIICnFERHH are 8-bit readable/writable registers.

Address(es): RIICnFER: <RIICn_base> + H'0014
 RIICnFERL: <RIICn_base> + H'0014, RIICnFERH: <RIICn_base> + H'0016
 RIICnFERLL: <RIICn_base> + H'0014, RIICnFERLH: <RIICn_base> + H'0015,
 RIICnFERHL: <RIICn_base> + H'0016, RIICnFERHH: <RIICn_base> + H'0017

Initial Value: H'0000 0072 This register is initialized by any reset.

Bit	31	30	29	28	27	26	25	24	23	22	21	20	19	18	17	16
	—	—	—	—	—	—	—	—	—	—	—	—	—	—	—	—
Initial Value	0	0	0	0	0	0	0	0	0	0	0	0	0	0	0	0
R/W	R	R	R	R	R	R	R	R	R	R	R	R	R	R	R	R
Bit	15	14	13	12	11	10	9	8	7	6	5	4	3	2	1	0
	—	—	—	—	—	—	—	—	FMPE	SCLE	NFE	NACKE	SALE	NALE	MALE	TMOE
Initial Value	0	0	0	0	0	0	0	0	0	1	1	1	0	0	1	0
R/W	R	R	R	R	R	R	R	R	R/W	R/W	R/W	R/W	R/W	R/W	R/W	R/W

Bit	Bit Name	Initial Value	R/W	Description
31 to 8	—	All 0	R	Reserved These bits are read as 0. The write value should be 0.
7	FMPE	0	R/W	Fast-mode Plus Enable 0: No fm+ slope control circuit is used for the SCLn pin and SDAn pin 1: An fm+ slope control circuit is used for the SCLn pin and SDAn pin
6	SCLE	1	R/W	SCL Synchronous Circuit Enable 0: No SCL synchronous circuit is used. 1: An SCL synchronous circuit is used.
5	NFE	1	R/W	Digital Noise Filter Circuit Enable 0: No digital noise filter circuit is used. 1: A digital noise filter circuit is used.
4	NACKE	1	R/W	NACK Reception Transfer Suspension Enable 0: Transfer operation is not suspended during NACK reception (transfer suspension disabled). 1: Transfer operation is suspended during NACK reception (transfer suspension enabled).
3	SALE	0	R/W	Slave Arbitration-Lost Detection Enable 0: Slave arbitration-lost detection is disabled. 1: Slave arbitration-lost detection is enabled.
2	NALE	0	R/W	NACK Transmission Arbitration-Lost Detection Enable 0: NACK transmission arbitration-lost detection is disabled. 1: NACK transmission arbitration-lost detection is enabled.
1	MALE	1	R/W	Master Arbitration-Lost Detection Enable 0: Master arbitration-lost detection is disabled. (Disables the arbitration-lost detection function and does not clear the RIICnCR2.MST and TRS bits automatically when arbitration is lost.) 1: Master arbitration-lost detection is enabled. (Enables the arbitration-lost detection function and clears the RIICnCR2.MST and TRS bits automatically when arbitration is lost.)

Bit	Bit Name	Initial Value	R/W	Description
0	TMOE	0	R/W	Timeout Function Enable 0: The timeout function is disabled. 1: The timeout function is enabled.

TMOE Bit (Timeout Function Enable)

This bit is used to enable or disable the timeout function.

For details on the timeout function, see **Section 26.13.1, Timeout Function**.

MALE Bit (Master Arbitration-Lost Detection Enable)

This bit is used to specify whether to use the arbitration-lost detection function in master mode. Normally, set this bit to 1.

NALE Bit (NACK Transmission Arbitration-Lost Detection Enable)

This bit is used to specify whether to cause arbitration to be lost when ACK is detected during transmission of NACK in receive mode (such as when slaves with the same address exist on the bus or when two or more masters select the same slave device simultaneously with different number of receive bytes).

SALE Bit (Slave Arbitration-Lost Detection Enable)

This bit is used to specify whether to cause arbitration to be lost when a value different from the value being transmitted is detected on the bus in slave transmit mode (such as when slaves with the same address exist on the bus or when a mismatch with the transmit data occurs due to noise).

NACKE Bit (NACK Reception Transfer Suspension Enable)

This bit is used to specify whether to continue or discontinue the transfer operation when NACK is received in transmit mode. Normally, set this bit to 1.

When NACK is received with the NACKE bit set to 1, the next transfer operation is suspended.

When the NACKE bit is 0, the next transfer operation is continued regardless of the received acknowledge content.

SCLE Bit (SCL Synchronous Circuit Enable)

This bit is used to specify whether to synchronize the SCL clock with the SCL input clock. Normally, set this bit to 1. When the SCLE bit is cleared to 0 (SCL synchronous circuit not used), the RIIC does not synchronize the SCL clock with the SCL input clock. In this setting, the RIIC outputs the SCL clock with the transfer rate set in RIICnBRH and RIICnBRL regardless of the SCL line state. For this reason, if the bus load of the I²C bus line is much larger than the specification value or if the SCL clock output overlaps in multiple masters, the short-cycle SCL clock that does not meet the specification may be output. When no SCL synchronous circuit is used, it also affects the issuance of a start condition, restart condition, and stop condition, and the continuous output of extra SCL clock cycles.

This bit must not be cleared to 0 except for checking the output of the transfer rate.

FMPE Bit (Fast-mode Plus Enable)

This bit is used to specify whether to use a slope control circuit for Fast-mode Plus [fm+].

When this bit is set to 1, a slope control circuit conforming to the Fast-mode Plus [fm+] slope control standard (tof) of the I²C bus is selected. When this bit is cleared to 0, a slope control circuit conforming to the Standard-mode [Sm] and Fast-mode [fm] slope control standard (tof) of the I²C bus is selected.

Set this bit to 1 when using the transmission rate within a range up to 1 Mbps (Fast-mode Plus[fm+]) of the I²C bus standard. Clear this bit to 0 when using the transmission rate at other rates (up to 100 kbps[Sm], up to 400 kbps[fm]) or for SMBus (10 to 100 kbps).

26.3.7 RIICnSER — I²C Bus Status Enable Register

Access Size: RIICnSER is a 32-bit readable/writable register.
 RIICnSERL and RIICnSERH are 16-bit readable/writable registers.
 RIICnSERLL, RIICnSERLH, RRIICnSERHL, and RIICnSERHH are 8-bit readable/writable registers.

Address(es): RIICnSER: <RIICn_base> + H'0018
 RIICnSERL: <RIICn_base> + H'0018, RIICnSERH: <RIICn_base> + H'001A
 RIICnSERLL: <RIICn_base> + H'0018, RIICnSERLH: <RIICn_base> + H'0019,
 RIICnSERHL: <RIICn_base> + H'001A, RIICnSERHH: <RIICn_base> + H'001B

Initial Value: H'0000 0009 This register is initialized by any reset.

Bit	31	30	29	28	27	26	25	24	23	22	21	20	19	18	17	16
	—	—	—	—	—	—	—	—	—	—	—	—	—	—	—	—
Initial Value	0	0	0	0	0	0	0	0	0	0	0	0	0	0	0	0
R/W	R	R	R	R	R	R	R	R	R	R	R	R	R	R	R	R
Bit	15	14	13	12	11	10	9	8	7	6	5	4	3	2	1	0
	—	—	—	—	—	—	—	—	HOAE	—	DIDE	—	GCE	SAR2	SAR1	SAR0
Initial Value	0	0	0	0	0	0	0	0	0	0	0	0	1	0	0	1
R/W	R	R	R	R	R	R	R	R	R/W	R	R/W	R	R/W	R/W	R/W	R/W

Bit	Bit Name	Initial Value	R/W	Description
31 to 8	—	All 0	R	Reserved These bits are read as 0. The write value should be 0.
7	HOAE	0	R/W	Host Address Enable 0: Host address detection is disabled. 1: Host address detection is enabled.
6	—	0	R	Reserved This bit is read as 0. The write value should be 0.
5	DIDE	0	R/W	Device-ID Address Detection Enable 0: Device-ID address detection is disabled. 1: Device-ID address detection is enabled.
4	—	0	R	Reserved This bit is read as 0. The write value should be 0.
3	GCE	1	R/W	General Call Address Enable 0: General call address detection is disabled. 1: General call address detection is enabled.
2	SAR2	0	R/W	Slave Address Register 2 Enable 0: Slave address in RIICnSAR2 is disabled. 1: Slave address in RIICnSAR2 is enabled.
1	SAR1	0	R/W	Slave Address Register 1 Enable 0: Slave address in RIICnSAR1 is disabled. 1: Slave address in RIICnSAR1 is enabled.
0	SAR0	1	R/W	Slave Address Register 0 Enable 0: Slave address in RIICnSAR0 is disabled. 1: Slave address in RIICnSAR0 is enabled.

SARy Bit (Slave Address Register y Enable) (y = 0 to 2)

This bit is used to enable or disable the received slave address and the slave address set in RIICnSARy.

When this bit is set to 1, the slave address set in RIICnSARy is enabled and is compared with the received slave address. When this bit is cleared to 0, the slave address set in RIICnSARy is disabled and is ignored even if it matches the received slave address.

GCE Bit (General Call Address Enable)

This bit is used to specify whether to ignore the general call address (0000 000b + 0 [W]: All 0) when it is received.

When this bit is set to 1, if the received slave address matches the general call address, the RIIC recognizes the received slave address as the general call address independently of the slave addresses set in RIICnSARy (y = 0 to 2) and performs data receive operation.

When this bit is cleared to 0, the received slave address is ignored even if it matches the general call address.

DIDE Bit (Device-ID Address Detection Enable)

This bit is used to specify whether to recognize and execute the Device-ID address when a device ID (1111 100b) is received in the first frame after a start condition or restart condition is detected.

When this bit is set to 1, if the received first frame matches the device ID, the RIIC recognizes that the Device-ID address has been received. When the following R/W# bit is 0 [W], the RIIC recognizes the second and the following frames as slave addresses and continues the receive operation.

When this bit is cleared to 0, the RIIC ignores the received first frame even if it matches the device ID address and recognizes the first frame as a normal slave address.

For details on the device-ID address detection, see **Section 26.9.3, Device-ID Address Detection**.

HOAE Bit (Host Address Enable)

This bit is used to specify whether to ignore received host address (0001 000b) when the RIICnMR3.SMBS bit is 1.

When this bit is set to 1 while the RIICnMR3.SMBS bit is 1, if the received slave address matches the host address, the RIIC recognizes the received slave address as the host address independently of the slave addresses set in RIICnSARy (y = 0 to 2) and performs the receive operation.

When the RIICnMR3.SMBS bit or the HOAE bit is cleared to 0, the received slave address is ignored even if it matches the host address.

26.3.8 RIICnIER — I²C Bus Interrupt Enable Register

- Access Size:** RIICnIER is a 32-bit readable/writable register.
 RIICnIERL and RIICnIERH are 16-bit readable/writable registers.
 RIICnIERLL, RIICnIERLH, RIICnIERHL, and RIICnIERHH are 8-bit readable/writable registers.
- Address(es):** RIICnIER: <RIICn_base> + H'001C
 RIICnIERL: <RIICn_base> + H'001C, RIICnIERH: <RIICn_base> + H'001E
 RIICnIERLL: <RIICn_base> + H'001C, RIICnIERLH: <RIICn_base> + H'001D,
 RIICnIERHL: <RIICn_base> + H'001E, RIICnIERHH: <RIICn_base> + H'001F
- Initial Value:** H'0000 0000 This register is initialized by any reset.

Bit	31	30	29	28	27	26	25	24	23	22	21	20	19	18	17	16
	—	—	—	—	—	—	—	—	—	—	—	—	—	—	—	—
Initial Value	0	0	0	0	0	0	0	0	0	0	0	0	0	0	0	0
R/W	R	R	R	R	R	R	R	R	R	R	R	R	R	R	R	R
Bit	15	14	13	12	11	10	9	8	7	6	5	4	3	2	1	0
	—	—	—	—	—	—	—	—	TIE	TEIE	RIE	NAKIE	SPIE	STIE	ALIE	TMOIE
Initial Value	0	0	0	0	0	0	0	0	0	0	0	0	0	0	0	0
R/W	R	R	R	R	R	R	R	R	R/W	R/W	R/W	R/W	R/W	R/W	R/W	R/W

Bit	Bit Name	Initial Value	R/W	Description
31 to 8	—	All 0	R	Reserved These bits are read as 0. The write value should be 0.
7	TIE	0	R/W	Transmit Data Empty Interrupt Enable 0: Transmit data empty interrupt request (INTRIICTI) is disabled. 1: Transmit data empty interrupt request (INTRIICTI) is enabled.
6	TEIE	0	R/W	Transmit End Interrupt Enable 0: Transmit end interrupt request (INTRIICTEI) is disabled. 1: Transmit end interrupt request (INTRIICTEI) is enabled.
5	RIE	0	R/W	Receive Data Full Interrupt Enable 0: Receive data full interrupt request (INTRIICRI) is disabled. 1: Receive data full interrupt request (INTRIICRI) is enabled.
4	NAKIE	0	R/W	NACK Reception Interrupt Enable 0: NACK reception interrupt request (INTRIICNAKI) is disabled. 1: NACK reception interrupt request (INTRIICNAKI) is enabled.
3	SPIE	0	R/W	Stop Condition Detection Interrupt Enable 0: Stop condition detection interrupt request (INTRIICSPI) is disabled. 1: Stop condition detection interrupt request (INTRIICSPI) is enabled.
2	STIE	0	R/W	Start Condition Detection Interrupt Enable 0: Start condition detection interrupt request (INTRIICSTI) is disabled. 1: Start condition detection interrupt request (INTRIICSTI) is enabled.
1	ALIE	0	R/W	Arbitration-Lost Interrupt Enable 0: Arbitration-lost interrupt request (INTRIICALI) is disabled. 1: Arbitration-lost interrupt request (INTRIICALI) is enabled.
0	TMOIE	0	R/W	Timeout Interrupt Enable 0: Timeout interrupt request (INTRIICTMOI) is disabled. 1: Timeout interrupt request (INTRIICTMOI) is enabled.

TMOIE Bit (Timeout Interrupt Enable)

This bit is used to enable or disable timeout interrupt requests (INTRIICTMOI) when the RIICnSR2.TMOF flag is set to 1. An INTRIICTMOI interrupt request is canceled by clearing the TMOF flag or the TMOIE bit to 0.

ALIE Bit (Arbitration-Lost Interrupt Enable)

This bit is used to enable or disable arbitration-lost interrupt requests (INTRIICALII) when the RIICnSR2.AL flag is set to 1. An INTRIICALII interrupt request is canceled by clearing the AL flag or the ALIE bit to 0.

STIE Bit (Start Condition Detection Interrupt Enable)

This bit is used to enable or disable start condition detection interrupt requests (INTRIICSTI) when the RIICnSR2.START flag is set to 1. An INTRIICSTI interrupt request is canceled by clearing the START flag or the STIE bit to 0.

SPIE Bit (Stop Condition Detection Interrupt Enable)

This bit is used to enable or disable stop condition detection interrupt requests (INTRIICSPI) when the RIICnSR2.STOP flag is set to 1. An INTRIICSPI interrupt request is canceled by clearing the STOP flag or the SPIE bit to 0.

NAKIE Bit (NACK Reception Interrupt Enable)

This bit is used to enable or disable NACK reception interrupt requests (INTRIICNAKI) when the RIICnSR2.NACKF flag is set to 1. An INTRIICNAKI interrupt request is canceled by clearing the NACKF flag or the NAKIE bit to 0.

RIE Bit (Receive Data Full Interrupt Enable)

This bit is used to enable or disable receive data full interrupt requests (INTRIICRI) when the RIICnSR2.RDRF flag in ICSR2 is set to 1. An INTRIICRI interrupt request is canceled by clearing the RDRF flag or the RIE bit to 0.

TEIE Bit (Transmit End Interrupt Enable)

This bit is used to enable or disable transmit end interrupts (INTRIICTEI) when the RIICnSR2.TEND flag is set to 1. An INTRIICTEI interrupt request is canceled by clearing the TEND flag or the TEIE bit to 0.

TIE Bit (Transmit Data Empty Interrupt Enable)

This bit is used to enable or disable transmit data empty interrupts (INTRIICTI) when the RIICnSR2.TDRE flag is set to 1.

26.3.9 RIICnSR1 — I²C Bus Status Register 1

Access Size: RIICnSR1 is a 32-bit readable/writable register.
 RIICnSR1L and RIICnSR1H are 16-bit readable/writable registers.
 RIICnSR1LL, RIICnSR1LH, RIICnSR1HL, and RIICnSR1HH are 8/1-bit readable/writable registers.

Address(es): RIICnSR1: <RIICn_base> + H'0020
 RIICnSR1L: <RIICn_base> + H'0020, RIICnSR1H: <RIICn_base> + H'0022
 RIICnSR1LL: <RIICn_base> + H'0020, RIICnSR1LH: <RIICn_base> + H'0021,
 RIICnSR1HL: <RIICn_base> + H'0022, RIICnSR1HH: <RIICn_base> + H'0023

Initial Value: H'0000 0000 This register is initialized by any reset.

Bit	31	30	29	28	27	26	25	24	23	22	21	20	19	18	17	16
	—	—	—	—	—	—	—	—	—	—	—	—	—	—	—	—
Initial Value	0	0	0	0	0	0	0	0	0	0	0	0	0	0	0	0
R/W	R	R	R	R	R	R	R	R	R	R	R	R	R	R	R	R
Bit	15	14	13	12	11	10	9	8	7	6	5	4	3	2	1	0
	—	—	—	—	—	—	—	—	HOA	—	DID	—	—	—	—	—
Initial Value	0	0	0	0	0	0	0	0	0	0	0	0	0	0	0	0
R/W	R	R	R	R	R	R	R	R	R/(W)*1	R	R/(W)*1	R	R/W*1	R/(W)*1	R/(W)*1	R/(W)*1

Bit	Bit Name	Initial Value	R/W	Description
31 to 8	—	All 0	R	Reserved These bits are read as 0. The write value should be 0.
7	HOA	0	R/(W) *1	Host Address Detection Flag 0: Host address is not detected. 1: Host address is detected.
6	—	0	R	Reserved This bit is read as 0. The write value should be 0.
5	DID	0	R/(W) *1	Device-ID Address Detection Flag 0: Device-ID command is not detected. 1: Device-ID command is detected.
4	—	0	R	Reserved This bit is read as 0. The write value should be 0.
3	GCA	0	R/W *1	General Call Address Detection Flag 0: General call address is not detected. 1: General call address is detected.
2	AAS2	0	R/(W) *1	Slave Address 2 Detection Flag 0: Slave address 2 is not detected. 1: Slave address 2 is detected.
1	AAS1	0	R/(W) *1	Slave Address 1 Detection Flag 0: Slave address 1 is not detected. 1: Slave address 1 is detected.
0	AAS0	0	R/(W) *1	Slave Address 0 Detection Flag 0: Slave address 0 is not detected. 1: Slave address 0 is detected.

Note 1. Only 0 can be written to this bit.

AASy Flag (Slave Address y Detection) (y = 0 to 2)

[Setting conditions]

<For 7-bit address format: RIICnSARy.FSy = 0>

When the received slave address matches the RIICnSARy.SVA[7:1] value with the RIICnSER.SARy bit set to 1 (slave address y detection enabled)

This flag is set to 1 at the rising edge of the ninth SCL clock cycle in the frame.

<For 10-bit address format: RIICnSARy.FSy = 1>

When the received slave address matches a value of (1111 0b + RIICnSARy.SVA[9:8]) and the following address matches the RIICnSARy.SVA[7:0] value with the RIICnSER.SARy bit set to 1 (slave address y detection enabled)

This flag is set to 1 at the rising edge of the ninth SCL clock cycle in the frame.

[Clearing conditions]

- When 0 is written to the AASy bit after reading AASy = 1
- When a stop condition is detected
- When 1 is written to the RIICnCR1.IICRST bit to apply an RIIC reset or an internal reset

<For 7-bit address format: RIICnSARy.FSy = 0>

- When the received slave address does not match the RIICnSARy.SVA[7:1] value with the RIICnSER.SARy bit set to 1 (slave address y detection enabled)

This flag is cleared to 0 at the rising edge of the ninth SCL clock cycle in the frame.

<For 10-bit address format: RIICnSARy.FSy = 1>

- When the received slave address does not match a value of (1111 0b + RIICnSARy.SVA[9:8]) with the RIICnSER.SARy bit set to 1 (slave address y detection enabled)
- When the received slave address matches a value of (1111 0b + RIICnSARy.SVA[9:8]) and the following address does not match the RIICnSARy.SVA[7:0] value with the RIICnSER.SARy bit set to 1 (slave address y detection enabled)

This flag is cleared to 0 at the rising edge of the ninth SCL clock cycle in the frame.

GCA Flag (General Call Address Detection)

[Setting condition]

When the received slave address matches the general call address (0000 000b + 0 [W]) with the RIICnSER.GCE bit set to 1 (general call address detection enabled)

This flag is set to 1 at the rising edge of the ninth SCL clock cycle in the frame.

[Clearing conditions]

- When 0 is written to the GCA bit after reading GCA = 1
 - When a stop condition is detected
 - When the received slave address does not match the general call address (0000 000b + 0 [W]) with the RIICnSER.GCE bit set to 1 (general call address detection enabled)
- This flag is cleared to 0 at the rising edge of the ninth SCL clock cycle in the frame.
- When 1 is written to the RIICnCR1.IICRST bit to apply an RIIC reset or an internal reset

DID Flag (Device-ID Address Detection)

[Setting condition]

- When the first frame received immediately after a start condition or restart condition is detected matches a value of (device ID (1111 100b) + 0 [W]) with the RIICnSER.DIDE bit set to 1 (Device-ID address detection enabled) This flag is set to 1 at the rising edge of the ninth SCL clock cycle in the frame.
- When a restart condition is detected after a match with the device ID address and the device ID address (1111 100b) + 1 [R] has matched with the RIICnSER.DIDE bit set to 1 (Device-ID address detection enabled) This flag is set to 1 at the rising edge of the ninth SCL clock cycle in the frame.

[Clearing conditions]

- When 0 is written to the DID bit after reading DID = 1
- When a stop condition is detected
- When the first frame received immediately after a start condition or restart condition is detected does not match a value of (device ID (1111 100b)) with the RIICnSER.DIDE bit set to 1 (Device-ID address detection enabled) This flag is cleared to 0 at the rising edge of the ninth SCL clock cycle in the frame.
- When the first frame received immediately after a start condition or restart condition is detected matches a value of (device ID (1111 100b) + 0 [W]) and the second frame does not match any of slave addresses 0 to 2 with the RIICnSER.DIDE bit set to 1 (Device-ID address detection enabled) This flag is cleared to 0 at the rising edge of the ninth SCL clock cycle in the frame.
- When 1 is written to the RIICnCR1.IICRST bit to apply an RIIC reset or an internal reset

HOA Flag (Host Address Detection)

[Setting condition]

When the received slave address matches the host address (0001 000b) while the RIICnMR3.SMBS bit and RIICnSER.HOAE bit are set to 1 (host address detection enabled)

This flag is set to 1 at the rising edge of the ninth SCL clock cycle in the frame.

[Clearing conditions]

- When 0 is written to the HOA bit after reading HOA = 1
- When a stop condition is detected
- When 0 is written to the RIICnMR3.SMBS bit in ICMR3 or the RIICnSER.HOAE bit
- When the received slave address does not match the host address (0001 000b) with the RIICnSER.HOAE bit set to 1 (host address detection enabled) This flag is cleared to 0 at the rising edge of the ninth SCL clock cycle in the frame.
- When 1 is written to the RIICnCR1.IICRST bit 1 to apply an RIIC reset or an internal reset

26.3.10 RIICnSR2 — I²C Bus Status Register 2

Access Size: RIICnSR2 is a 32-bit readable/writable register.
 RIICnSR2L and RIICnSR2H are 16-bit readable/writable registers.
 RIICnSR2LL, RIICnSR2LH, RIICnSR2HL, and RIICnSR2HH are 8/1-bit readable/writable registers.

Address(es): RIICnSR2: <RIICn_base> + H'0024
 RIICnSR2L: <RIICn_base> + H'0024, RIICnSR2H: <RIICn_base> + H'0026
 RIICnSR2LL: <RIICn_base> + H'0024, RIICnSR2LH: <RIICn_base> + H'0025,
 RIICnSR2HL: <RIICn_base> + H'0026, RIICnSR2HH: <RIICn_base> + H'0027

Initial Value: H'0000 0000 This register is initialized by any reset.

Bit	31	30	29	28	27	26	25	24	23	22	21	20	19	18	17	16
	—	—	—	—	—	—	—	—	—	—	—	—	—	—	—	—
Initial Value	0	0	0	0	0	0	0	0	0	0	0	0	0	0	0	0
R/W	R	R	R	R	R	R	R	R	R	R	R	R	R	R	R	R
Bit	15	14	13	12	11	10	9	8	7	6	5	4	3	2	1	0
	—	—	—	—	—	—	—	—	TDRE	TEND	RDRF	NACKF	STOP	STAT	AL	TMOF
Initial Value	0	0	0	0	0	0	0	0	0	0	0	0	0	0	0	0
R/W	R	R	R	R	R	R	R	R	R	R(W)*1	R(W)*1	R(W)*1	R(W)*1	R(W)*1	R(W)*1	R(W)*1

Bit	Bit Name	Initial Value	R/W	Description
31 to 8	—	All 0	R	Reserved These bits are read as 0. The write value should be 0.
7	TDRE	0	R	Transmit Data Empty Flag 0: RIICnDRT contains transmit data. 1: RIICnDRT contains no transmit data.
6	TEND	0	R(W) *1	Transmit End Flag 0: Data is being transmitted. 1: Data has been transmitted.
5	RDRF	0	R(W) *1	Receive Data Full Flag 0: RIICnDRR contains no receive data. 1: RIICnDRR contains receive data.
4	NACKF	0	R(W) *1	NACK Reception Flag 0: NACK is not received. 1: NACK is received.
3	STOP	0	R(W) *1	Stop Condition Detection Flag 0: Stop condition is not detected. 1: Stop condition is detected.
2	START	0	R(W) *1	Start Condition Detection Flag 0: Start condition is not detected. 1: Start condition is detected.
1	AL	0	R(W) *1	Arbitration-Lost Flag 0: Arbitration is not lost. 1: Arbitration is lost.
0	TMOF	0	R(W) *1	Timeout Flag 0: No timeout has occurred. 1: Timeout has occurred.

Note 1. Only 0 can be written to this bit.

TMOF Flag (Timeout)

This flag is set to 1 when the RIIC recognizes timeout after the SCL line state remains unchanged for a certain period.
[Setting condition]

The timeout function is enabled when the RIICnFER.TMOE bit is 1. It detects an abnormal bus state that the SCL line is held low or high during the following conditions:

- The bus is busy (RIICnCR2.BBSY = 1) in master mode (RIICnCR2.MST = 1).
- The slave address matches that of this module (RIICnSR1 register is not H'00) and the bus is busy (RIICnCR2.BBSY = 1) in slave mode (RIICnCR2.MST = 0).
- Issuing of a start condition is being requested (RIICnCR2.ST = 1) and the bus is free (RIICnCR2.BBSY = 0).

[Clearing conditions]

- When 0 is written to the TMOF bit after reading TMOF = 1
- When 1 is written to the RIICnCR1.IICRST bit to apply an RIIC reset or an internal reset

AL Flag (Arbitration-Lost)

This flag shows that bus mastership has been lost (loss in arbitration) due to a bus conflict or some other reason when a start condition is issued or an address and data are transmitted. The RIIC monitors the level on the SDA line during transmission and, if the level on the line does not match the value of the bit being output, sets the value of the AL bit to 1 to indicate that the bus is occupied by another device.

The RIIC can also set the flag to indicate the detection of loss of arbitration during NACK transmission in receive mode or during data transmission in slave mode.

[Setting conditions]

<When master arbitration-lost detection is enabled: RIICnFER.MALE = 1>

- When the internal SDA output state does not match the SDA line level at the rising edge of SCL clock except for the ACK period during data (including slave address) transmission in master transmit mode (when the SDA line is driven low while the internal SDA output is at a high level (the SDA pin is in the high-impedance state))
- When a start condition is detected while the RIICnCR2.ST bit is 1 (start condition issuance request) or the internal SDA output state does not match the SDA line level
- When the RIICnCR2.ST bit is set to 1 (start condition issuance request) with the RIICnCR2.BBSY flag set to 1.

<When NACK arbitration-lost detection is enabled: RIICnFER.NALE = 1>

When the internal SDA output state does not match the SDA line level at the rising edge of SCL clock in the ACK period during NACK transmission in receive mode

<When slave arbitration-lost detection is enabled: RIICnFER.SALE = 1>

When the internal SDA output state does not match the SDA line level at the rising edge of SCL clock except for the ACK period during data transmission in slave transmit mode

[Clearing conditions]

- When 0 is written to the AL bit after reading AL = 1
- When 1 is written to the RIICnCR1.IICRST bit to apply an RIIC reset or an internal reset

Table 26.7 Relationship between Arbitration-Lost Generation Sources and Arbitration-Lost Enable Functions

RIICnFER			RIICnSR2	Error	Arbitration-Lost Generation Source
MALE	NALE	SALE	AL		
1	x	x	1	Start condition issuance error	When internal SDA output state does not match SDA line level when a start condition is detected while the RIICnCR2.ST bit is 1
			1		When RIICnCR2.ST is set to 1 with RIICnCR2.BBSY set to 1
x	1	x	1	NACK transmission mismatch	When ACK is detected during transmission of NACK in master receive mode or slave receive mode
x	x	1	1	Transmit data mismatch	When transmit data does not match the bus state in slave transmit mode

Note: x: Don't care

START Flag (Start Condition Detection)

[Setting condition]

When a start condition (or a restart condition) is detected

[Clearing conditions]

- When 0 is written to the START bit after reading START = 1
- When a stop condition is detected
- When 1 is written to the RIICnCR1.IICRST bit to apply an RIIC reset or an internal reset

STOP Flag (Stop Condition Detection)

[Setting condition]

When a stop condition is detected

[Clearing conditions]

- When 0 is written to the STOP bit after reading STOP = 1
- When 1 is written to the RIICnCR1.IICRST bit to apply an RIIC reset or an internal reset

NACKF Flag (NACK Reception)

[Setting condition]

When acknowledge is not received (NACK is received) from the receive device in transmit mode with the RIICnFER.NACKE bit set to 1 (transfer suspension enabled)

[Clearing conditions]

- When 0 is written to the NACKF bit after reading NACKF = 1
- When 1 is written to the RIICnCR1.IICRST bit to apply an RIIC reset or an internal reset

CAUTION

When the NACKF flag is set to 1, the RIIC suspends data transmission/reception. Writing to RIICnDRT in transmit mode or reading from RIICnDRR in receive mode with the NACKF flag set to 1 does not enable data transmit/ receive operation. To restart data transmission/reception, clear the NACKF flag to 0.

RDRF Flag (Receive Data Full)

[Setting conditions]

- Slave receive mode
 - When the received slave address matches and the RIICnCR2.TRS bit is cleared to 0 after a start condition (or a restart condition) is detected
 - At the rising edge of the eighth or ninth SCL clock cycle (selected by the RIICnMR3.RDRFS bit) after receive data is transferred from RIICnDRS to RIICnDRR
- Master receive mode
 - When the slave address and the data direction are transmitted and the receive mode is entered (the RIICnCR2.TRS bit is set to 1) after a start condition (or a restart condition) is issued
 - At the rising edge of the eighth or ninth SCL clock cycle (selected by the RIICnMR3.RDRFS bit) after receive data is transferred from RIICnDRS to RIICnDRR

[Clearing conditions]

- When 0 is written to the RDRF bit after reading RDRF = 1
- When data is read from RIICnDRR
- When 1 is written to the RIICnCR1.IICRST bit to apply an RIIC reset or an internal reset

TEND Flag (Transmit End)

[Setting condition]

At the rising edge of the ninth SCL clock cycle while the TDRE flag is 1

[Clearing conditions]

- When 0 is written to the TEND bit after reading TEND = 1
- When data is written to RIICnDRT
- When a stop condition is detected
- When 1 is written to the RIICnCR1.IICRST bit to apply an RIIC reset or an internal reset

TDRE Flag (Transmit Data Empty)

[Setting conditions]

- When data has been transferred from RIICnDRT to RIICnDRS and RIICnDRT becomes empty
- When the RIICnCR2.TRS bit is set to 1
 - When the RIICnCR2.MST bit is set to 1 after a start condition (or a restart condition) is detected
 - When the RIIC enters transmit mode from receive mode
- When the received slave address matches while the TRS bit is 1

[Clearing conditions]

- When data is written to RIICnDRT
- When the RIICnCR2.TRS bit is cleared to 0
 - When a stop condition is detected
 - When the RIIC enters receive mode from transmit mode
- When 1 is written to the RIICnCR1.IICRST bit to apply an RIIC reset or an internal reset

CAUTION

When the NACKF flag is set to 1 while the RIICnFER.NACKE bit is 1, the RIIC suspends data transmission/ reception. Here, if the TDRE flag is 0 (next transmit data has been written), data is transferred to the RIICnDRS register and the RIICnDRT register becomes empty at the rising edge of the ninth clock cycle, but the TDRE flag is not set to 1.

26.3.11 RIICnSARy — I²C Slave Address Register y (y = 0 to 2)

Access Size: RIICnSARy is a 32-bit readable/writable register.
 RIICnSARyL and RIICnSARyH are 16-bit readable/writable registers.
 RIICnSARyLL, RIICnSARyLH, RIICnSARyHL, and RIICnSARyHH are 8-bit readable/writable registers.

Address(es): RIICnSAR0: <RIICn_base> + H'0028
 RIICnSAR0L: <RIICn_base> + H'0028, RIICnSAR0H: <RIICn_base> + H'002A
 RIICnSAR0LL: <RIICn_base> + H'0028, RIICnSAR0LH: <RIICn_base> + H'0029,
 RIICnSAR0HL: <RIICn_base> + H'002A, RIICnSAR0HH: <RIICn_base> + H'002B
 RIICnSAR1: <RIICn_base> + H'002C
 RIICnSAR1L: <RIICn_base> + H'002C, RIICnSAR1H: <RIICn_base> + H'002E
 RIICnSAR1LL: <RIICn_base> + H'002C, RIICnSAR1LH: <RIICn_base> + H'002D,
 RIICnSAR1HL: <RIICn_base> + H'002E, RIICnSAR1HH: <RIICn_base> + H'002F
 RIICnSAR2: <RIICn_base> + H'0030
 RIICnSAR2L: <RIICn_base> + H'0030, RIICnSAR2H: <RIICn_base> + H'0032
 RIICnSAR2LL: <RIICn_base> + H'0030, RIICnSAR2LH: <RIICn_base> + H'0031,
 RIICnSAR2HL: <RIICn_base> + H'0032, RIICnSAR2HH: <RIICn_base> + H'0033

Initial Value: H'0000 0000 This register is initialized by any reset.

Bit	31	30	29	28	27	26	25	24	23	22	21	20	19	18	17	16
	—	—	—	—	—	—	—	—	—	—	—	—	—	—	—	—
Initial Value	0	0	0	0	0	0	0	0	0	0	0	0	0	0	0	0
R/W	R	R	R	R	R	R	R	R	R	R	R	R	R	R	R	R
Bit	15	14	13	12	11	10	9	8	7	6	5	4	3	2	1	0
	FSy	—	—	—	—	—	SVA[9:1]									SVA0
Initial Value	0	0	0	0	0	0	0	0	0	0	0	0	0	0	0	0
R/W	R/W	R	R	R	R	R	R/W	R/W	R/W	R/W	R/W	R/W	R/W	R/W	R/W	R/W

Bit	Bit Name	Initial Value	R/W	Description
31 to 16	—	All 0	R	Reserved These bits are read as 0. The write value should be 0.
15	FSy	0	R/W	7-Bit/10-Bit Address Format Selection 0: The 7-bit address format is selected. 1: The 10-bit address format is selected.
14 to 10	—	All 0	R	Reserved These bits are read as 0. The write value should be 0.
9 to 1	SVA[9:1]	All 0	R/W	7-Bit Address/10-Bit Address Upper Bits A slave address is set. <ul style="list-style-type: none"> When the FSy bit is 0 (7-bit address format), the SVA[7:1] bits are Valid and form a 7-bit slave address. When the FSy bit is 1 (10-bit address format), SVA[9:1] bits form a 10-bit slave address (combined with the SVA0 bit).
0	SVA0	0	R/W	10-Bit Address LSB The least significant bit (LSB) of a 10-bit slave address is set. <ul style="list-style-type: none"> When the FSy bit is 0 (7-bit address format), this bit is invalid. When the FSy bit is 1 (10-bit address format), this bit is a 10-bit slave address (combined with the SVA[9:1] bits).

SVA0 Bit (10-Bit Address LSB)

When the 10-bit address format is selected (RIICnSARy.FSy = 1), this bit functions as the LSB of a 10-bit address and forms a 10-bit address in combination with the SVA[9:1] bits.

When the RIICnSER.SARy bit is set to 1 (RIICnSARy enabled) and the RIICnSARy.FSy bit is 1, this bit is valid. While the RIICnSARy.FSy bit or SARy bit is 0, the setting of this bit is ignored.

SVA[9:1] Bits (7-Bit Address/10-Bit Address Upper Bits)

When the 7-bit address format is selected (RIICnSARy.FSy = 0), these bits function as a 7-bit address. When the 10-bit address format is selected (RIICnSARy.FSy = 1), these bits function as a 10-bit address in combination with the SVA0 bit.

While the RIICnSER.SARy bit is 0, the setting of these bits is ignored.

FSy Bit (7-Bit/10-Bit Address Format Selection)

This bit is used to select 7-bit address or 10-bit address for slave address y (in RIICnSARy).

When the RIICnSER.SARy bit is set to 1 (RIICnSARy enabled) and the RIICnSARy.FSy bit is 0, the 7-bit address format is selected for slave address y, the RIICnSARy.SVA[7:1] setting is valid, and the settings of the SVA[9:8] bits and the RIICnSARy.SVA0 bit are ignored.

When the RIICnSER.SARy bit is set to 1 (RIICnSARy enabled) and the RIICnSARy.FSy bit is 1, the 10-bit address format is selected for slave address y and the settings of the SVA[9:1] bits and the SVA0 bit are valid.

While the RIICnSER.SARy bit is 0 (RIICnSARy disabled), the setting of the RIICnSARy.FSy bit is invalid.

26.3.12 RIICnBRL — I²C Bus Bit Rate Low-Level Register

Access Size: RIICnBRL is a 32-bit readable/writable register.
 RIICnBRLL and RIICnBRLH are 16-bit readable/writable registers.
 RIICnBRLLL, RIICnBRLLH, RIICnBRLHL, and RIICnBRLHH are 8-bit readable/writable registers.

Address(es): RIICnBRL: <RIICn_base> + H'0034
 RIICnBRLL: <RIICn_base> + H'0034, RIICnBRLH: <RIICn_base> + H'0036
 RIICnBRLLL: <RIICn_base> + H'0034, RIICnBRLLH: <RIICn_base> + H'0035,
 RIICnBRLHL: <RIICn_base> + H'0036, RIICnBRLHH: <RIICn_base> + H'0037

Initial Value: H'0000 00FF This register is initialized by any reset.

Bit	31	30	29	28	27	26	25	24	23	22	21	20	19	18	17	16
	—	—	—	—	—	—	—	—	—	—	—	—	—	—	—	—
Initial Value	0	0	0	0	0	0	0	0	0	0	0	0	0	0	0	0
R/W	R	R	R	R	R	R	R	R	R	R	R	R	R	R	R	R
Bit	15	14	13	12	11	10	9	8	7	6	5	4	3	2	1	0
	—	—	—	—	—	—	—	—	—	—	—	BRL[4:0]				
Initial Value	0	0	0	0	0	0	0	0	1	1	1	1	1	1	1	1
R/W	R	R	R	R	R	R	R	R	R	R	R	R/W	R/W	R/W	R/W	R/W

Bit	Bit Name	Initial Value	R/W	Description
31 to 8	—	All 0	R	Reserved These bits are read as 0. The write value should be 0.
7 to 5	—	All 1	R	Reserved These bits are read as 1. The write value should be 1.
4 to 0	BRL[4:0]	All 1	R/W	Bit Rate Low-Level Period Low-level period of SCL clock

The RIICnBRL register is a 5-bit register that is used to set the width at low level for the SCL clock.

It also works to generate the data setup time for automatic SCL low-hold operation (see **Section 26.10, Automatically Low-Hold Function for SCL**); when the RIIC is used only in slave mode, this register needs to be set to a value at least the same as the data setup time*1.

RIICnBRL counts the low-level period with the internal reference clock source (IIC ϕ) specified by the RIICnMR1.CKS[2:0] bits.

Note 1. Data setup time (t_{SU}: DAT)
 250 [ns] (0 to 100 [kbps]: standard mode (Sm))
 100 [ns] (0 to 400 [kbps]: fast mode (Fm))
 50 [ns] (0 to 1 [Mbps]: fast mode plus (Fm+))

26.3.13 RIICnBRH — I²C Bus Bit Rate High-Level Register

- Access Size:** RIICnBRH is a 32-bit readable/writable register.
 RIICnBRHL and RIICnBRHH are 16-bit readable/writable registers.
 RIICnBRHLL, RIICnBRHLH, RIICnBRHHL, and RIICnBRHHH are 8-bit readable/writable registers.
- Address(es):** RIICnBRH: <RIICn_base> + H'0038
 RIICnBRHL: <RIICn_base> + H'0038, RIICnBRHH: <RIICn_base> + H'003A
 RIICnBRHLL: <RIICn_base> + H'0038, RIICnBRHLH: <RIICn_base> + H'0039,
 RIICnBRHHL: <RIICn_base> + H'003A, RIICnBRHHH: <RIICn_base> + H'003B
- Initial Value:** H'0000 00FF This register is initialized by any reset.

Bit	31	30	29	28	27	26	25	24	23	22	21	20	19	18	17	16
	—	—	—	—	—	—	—	—	—	—	—	—	—	—	—	—
Initial Value	0	0	0	0	0	0	0	0	0	0	0	0	0	0	0	0
R/W	R	R	R	R	R	R	R	R	R	R	R	R	R	R	R	R
Bit	15	14	13	12	11	10	9	8	7	6	5	4	3	2	1	0
	—	—	—	—	—	—	—	—	—	—	—	BRH[4:0]				
Initial Value	0	0	0	0	0	0	0	0	1	1	1	1	1	1	1	1
R/W	R	R	R	R	R	R	R	R	R	R	R	R/W	R/W	R/W	R/W	R/W

Bit	Bit Name	Initial Value	R/W	Description
31 to 8	—	All 0	R	Reserved These bits are read as 0. The write value should be 0.
7 to 5	—	All 1	R	Reserved These bits are read as 1. The write value should be 1.
4 to 0	BRH[4:0]	All 1	R/W	Bit Rate High-Level Period High-level period of SCL clock

RIICnBRH is a 5-bit register to set the high-level period of SCL clock. RIICnBRH is valid in master mode. If the RIIC is used only in slave mode, this register need not to set the high-level period.

RIICnBRH counts the high-level period with the internal reference clock source (IIC ϕ) specified by the RIICnMR1.CKS[2:0] bits in ICMR1.

The frequency and duty cycle are calculated using one of the following expressions (1) to (5) according to the register settings.

CAUTION

The minimum value that can be specified in RIICnBRL and RIICnBRH is determined according to the values of the SCLE and NFE bits in RIICnFER and the NF bit in RIICnMR3. For details of the minimum specifiable value, see **Table 26.8**.

- (1) When SCLE = 0

$$\text{Frequency} = 1 / \{[(\text{BRH} + 1) + (\text{BRL} + 1)] / \text{IIC}\phi + \text{tr} + \text{tf}\}$$

$$\text{Duty cycle} = \{\text{tr} + (\text{BRH} + 1) / \text{IIC}\phi\} / \{\text{tr} + \text{tf} + [(\text{BRH} + 1) + (\text{BRL} + 1)] / \text{IIC}\phi\}$$

- (2) When SCLE = 1, NFE = 0, CKS = 000 (IIC ϕ = P0 ϕ) Frequency = 1 / {[(BRH + 3) + (BRL + 3)] / IIC ϕ + tr + tf}

$$\text{Duty cycle} = \{\text{tr} + (\text{BRH} + 3) / \text{IIC}\phi\} / \{\text{tr} + \text{tf} + [(\text{BRH} + 3) + (\text{BRL} + 3)] / \text{IIC}\phi\}$$

- (3) When SCLE = 1, NFE = 1, CKS = 000 (IIC ϕ = P0 ϕ)
 Frequency = $1 / \{[(BRH + 3 + nf) + (BRL + 3 + nf)] / IIC\phi + tr + tf\}$
 Duty cycle = $\{tr + (BRH + 3 + nf) / IIC\phi\} / \{tr + tf + [(BRH + 3 + nf) + (BRL + 3 + nf)] / IIC\phi\}$
- (4) When SCLE = 1, NFE = 0, CKS = 1 000 (IIC ϕ < P0 ϕ)
 Frequency = $1 / \{[(BRH + 2) + (BRL + 2)] / IIC\phi + tr + tf\}$
 Duty cycle = $\{tr + (BRH + 2) / IIC\phi\} / \{tr + tf + [(BRH + 2) + (BRL + 2)] / IIC\phi\}$
- (5) When SCLE = 1, NFE = 1, CKS = 1 000 (IIC ϕ < P0 ϕ)
 Frequency = $1 / \{[(BRH + 2 + nf) + (BRL + 2 + nf)] / IIC\phi + tr + tf\}$
 Duty cycle = $\{tr + (BRH + 2 + nf) / IIC\phi\} / \{tr + tf + [(BRH + 2 + nf) + (BRL + 2 + nf)] / IIC\phi\}$

Symbols in the expressions

SCLE: RIICnFER.SCLE bit

BRH: RIICnBRH.BRH[4:0] bits

BRL: RIICnBRL.BRL[4:0] bits

CKS: RIICnMR1.CKS bits

NFE: RIICnFER.NFE bit

IIC ϕ : Internal reference clock selected by the CKS bits

tf: SCL signal falling time [s]*¹

tr: SCL signal rising time [s]*¹

nf: Number of digital noise filter stages specified in the RIICnMR3.NF[1:0] bits

Note 1. The rising time (tr) and falling time (tf) of the SCL signal depend on the total capacitance of the bus line (Cb) and pull-up resistor (Rp). For details, see I²C Bus Standard from NXP Semiconductors.

Table 26.8 Minimum Specifiable Value for RIICnBRL and RIICnBRH

SCLE	NFE	nf	Minimum Pulse Width that Passes through Digital Filter	Minimum Specifiable Value for BRH and BRL	Pulse Width when Minimum Value is Specified
0	0	—	1 × IIC ϕ	1	2 × IIC ϕ
0	1	1	2 × IIC ϕ	2	3 × IIC ϕ
0	1	2	3 × IIC ϕ	3	4 × IIC ϕ
0	1	3	4 × IIC ϕ	4	5 × IIC ϕ
0	1	4	5 × IIC ϕ	5	6 × IIC ϕ
IIC ϕ cycle > P0 ϕ cycle (CKS ≠ 000)					
1	0	—	1 × IIC ϕ	0	2 × IIC ϕ
1	1	1	2 × IIC ϕ	1	4 × IIC ϕ
1	1	2	3 × IIC ϕ	2	6 × IIC ϕ
1	1	3	4 × IIC ϕ	3	8 × IIC ϕ
1	1	4	5 × IIC ϕ	4	10 × IIC ϕ
IIC ϕ cycle = P0 ϕ cycle (CKS = 000)					
1	0	—	2 × P0 ϕ	0	3 × IIC ϕ
1	1	1	3 × P0 ϕ	1	5 × IIC ϕ
1	1	2	4 × P0 ϕ	2	7 × IIC ϕ
1	1	3	5 × P0 ϕ	3	9 × IIC ϕ
1	1	4	6 × P0 ϕ	4	11 × IIC ϕ

Table 26.9 and **Table 26.10** list examples of RIICnBRH/RIICnBRL settings.

Table 26.9 Examples of RIICnBRH/RIICnBRL Settings for Transfer Rate (when RIICnFER.SCLE = 1 and RIICnFER.NFE = 0)

Transfer Rate [kbps]	Peripheral Clock Operating Frequency P0φ [MHz]			
	100			
	RIICnMR1.CKS[2:0]	RIICnBRH.BRH	RIICnBRL.BRL	Actual transfer rate [kbps]
12	111b	30 (H'FE)	31 (H'FF)	12
50	101b	28 (H'FC)	30 (H'FE)	50.4
100	100b	28 (H'FC)	31 (H'FF)	99.2
400	010b	29 (H'FD)	30 (H'FE)	396.8
1000	001b	20 (H'F4)	25 (H'F9)	1020.4

Table 26.10 Examples of RIICnBRH/RIICnBRL Settings for Transfer Rate (when RIICnFER.SCLE = 1, RIICnFER.NFE = 1, and Number of NF Stages = 4)

Transfer Rate [kbps]	Peripheral Clock Operating Frequency P0φ [MHz]			
	100			
	RIICnMR1.CKS[2:0]	RIICnBRH.BRH	RIICnBRL.BRL	Actual transfer rate [kbps]
12	111b	25 (H'F9)	28 (H'FC)	12
50	101b	23 (H'F7)	28 (H'FC)	49.6
100	100b	24 (H'F8)	27 (H'FB)	99.2
400	010b	25 (H'F9)	26 (H'FA)	396.8
1000	001b	14 (H'EE)	24 (H'F8)	1000

26.3.14 RIICnDRT — I²C Bus Transmit Data Register

Access Size: RIICnDRT is a 32-bit readable/writable register.
 RIICnDRTL and RIICnDRTH are 16-bit readable/writable registers.
 RIICnDRTLL, RIICnDRTLH, RIICnDRTHL, and RIICnDRTHH are 8-bit readable/writable registers.

Address(es): RIICnDRT: <RIICn_base> + H'003C
 RIICnDRTL: <RIICn_base> + H'003C, RIICnDRTH: <RIICn_base> + H'003E
 RIICnDRTLL: <RIICn_base> + H'003C, RIICnDRTLH: <RIICn_base> + H'003D,
 RIICnDRTHL: <RIICn_base> + H'003E, RIICnDRTHH: <RIICn_base> + H'003F

Initial Value: H'0000 00FF This register is initialized by any reset.

Bit	31	30	29	28	27	26	25	24	23	22	21	20	19	18	17	16
	—	—	—	—	—	—	—	—	—	—	—	—	—	—	—	—
Initial Value	0	0	0	0	0	0	0	0	0	0	0	0	0	0	0	0
R/W	R	R	R	R	R	R	R	R	R	R	R	R	R	R	R	R
Bit	15	14	13	12	11	10	9	8	7	6	5	4	3	2	1	0
	—	—	—	—	—	—	—	—	DRT[7:0]							
Initial Value	0	0	0	0	0	0	0	0	1	1	1	1	1	1	1	1
R/W	R	R	R	R	R	R	R	R	R/W	R/W	R/W	R/W	R/W	R/W	R/W	R/W

When RIICnDRT detects a space in the I²C bus shift register (RIICnDRS), it transfers the transmit data that has been written to RIICnDRT to RIICnDRS and starts transmitting data in transmit mode.

The double-buffer structure of RIICnDRT and RIICnDRS allows continuous transmit operation if the next transmit data has been written to RIICnDRT while the RIICnDRS data is being transmitted.

RIICnDRT can always be read and written. Write transmit data to RIICnDRT once when a transmit data empty interrupt (INTRIICTI) request is generated. When writing to bits 8 to 15, be sure to write 0 to these bits.

26.3.15 RIICnDRR — I²C Bus Receive Data Register

Access Size: RIICnDRR is a 32-bit readable/writable register.
 RIICnDRRL and RIICnDRRH are 16-bit readable/writable registers.
 RIICnDRRLL, RIICnDRRLH, RIICnDRRHLL, and RIICnDRRHHL are 8-bit readable/writable registers.

Address(es): RIICnDRR: <RIICn_base> + H'0040
 RIICnDRRL: <RIICn_base> + H'0040, RIICnDRRH: <RIICn_base> + H'0042
 RIICnDRRLL: <RIICn_base> + H'0040, RIICnDRRLH: <RIICn_base> + H'0041,
 RIICnDRRHLL: <RIICn_base> + H'0042, RIICnDRRHHL: <RIICn_base> + H'0043

Initial Value: H'0000 0000 This register is initialized by any reset.

Bit	31	30	29	28	27	26	25	24	23	22	21	20	19	18	17	16
	—	—	—	—	—	—	—	—	—	—	—	—	—	—	—	—
Initial Value	0	0	0	0	0	0	0	0	0	0	0	0	0	0	0	0
R/W	R	R	R	R	R	R	R	R	R	R	R	R	R	R	R	R
Bit	15	14	13	12	11	10	9	8	7	6	5	4	3	2	1	0
	—	—	—	—	—	—	—	—	DRR[7:0]							
Initial Value	0	0	0	0	0	0	0	0	0	0	0	0	0	0	0	0
R/W	R	R	R	R	R	R	R	R	R	R	R	R	R	R	R	R

When 1 byte of data has been received, the received data is transferred from the I²C bus shift register (RIICnDRS) to RIICnDRR to enable the next data to be received.

The double-buffer structure of RIICnDRS and RIICnDRR allows continuous receive operation if the received data has been read from RIICnDRR while RIICnDRS is receiving data.

RIICnDRR cannot be written. Read data from RIICnDRR once when a receive data full interrupt (INTRIICRI) request is generated.

If DRR receives the next receive data before the current data is read from RIICnDRR (while the RIICnSR2.RDRF flag is 1), the RIIC automatically holds the SCL clock low one cycle before the RDRF flag is set to 1 next.

26.3.16 RIICnDRS — I²C Bus Shift Register

Access Size: This register is not accessible.

Address(es): —

Initial Value: H'0000 00FF

Bit	31	30	29	28	27	26	25	24	23	22	21	20	19	18	17	16
	—	—	—	—	—	—	—	—	—	—	—	—	—	—	—	—
Initial Value	0	0	0	0	0	0	0	0	0	0	0	0	0	0	0	0
R/W	—	—	—	—	—	—	—	—	—	—	—	—	—	—	—	—
Bit	15	14	13	12	11	10	9	8	7	6	5	4	3	2	1	0
	—	—	—	—	—	—	—	—	DRS[7:0]							
Initial Value	0	0	0	0	0	0	0	0	1	1	1	1	1	1	1	1
R/W	—	—	—	—	—	—	—	—	—	—	—	—	—	—	—	—

RIICnDRS is an 8-bit shift register to transmit and receive data.

During transmission, transmit data is transferred from RIICnDRT to RIICnDRS and is sent from the SDA pin. During reception, data is transferred from RIICnDRS to RIICnDRR after 1 byte of data has been received.

RIICnDRS cannot be accessed directly.

26.4 Interrupt Sources

The RIIC issues eight types of interrupt request: transmit end, receive data full, transmit data empty, stop condition detection, start condition detection, NACK reception, arbitration-lost, and timeout.

Table 26.11 lists details of the several interrupt requests. The receive data full and transmit data empty sources are both capable of launching data transfer by the DMAC.

Table 26.11 Interrupt Sources

Symbol	Interrupt Source	Interrupt Flag	DMAC Launching	Priority* ¹	Interrupt Condition
INTRIICRI	Receive-data-full	RDRF	Possible	High ↑	$RDRF = 1 \cdot RIE = 1$
INTRIICTI	Transmit-data-empty	TDRE	Possible		$TDRE = 1 \cdot TIE = 1$
INTRIICTEI	Transmission complete	TEND	Not possible		$TEND = 1 \cdot TEIE = 1$
INTRIICNAKI	Reception of a NACK	NACKF	Not possible		$NACKF = 1 \cdot NAKIE = 1$
INTRIICSPI	Detection of a stop condition	STOP	Not possible		$STOP = 1 \cdot SPIE = 1$
INTRIICSTI	Detection of a start condition	START	Not possible		$START = 1 \cdot STIE = 1$
INTRIICALI	Arbitration lost	AL	Not possible		$AL = 1 \cdot ALIE = 1$
INTRIICTMOI	Timeout	TMOF	Not possible	Low	$TMOF = 1 \cdot TMOIE = 1$

Note 1. When the interrupt priority register (ICDIPRn) setting is the same

Clear or mask the each flag during interrupt handling.

CAUTIONS

1. There is a latency (delay) between the execution of a write instruction for a peripheral module by the CPU and actual writing to the module. Thus, when an interrupt flag has been cleared or masked, read the relevant flag again to check whether clearing or masking has been completed, and then return from interrupt processing. Returning from interrupt processing without checking that writing to the module has been completed creates a possibility of repeated processing of the same interrupt.
2. Since INTRIICRI and INTRIICTI are edge-detected interrupts, they do not require clearing.
3. When using the INTRIICTEI interrupt, clear the RIICnSR2.TEND flag in the INTRIICTEI interrupt processing.
4. When using the INTRIICSPI interrupt, clear the RIICnSR2.STOP flag in the INTRIICSPI interrupt processing.
5. When using the INTRIICSTI interrupt, clear the RIICnSR2.START flag in the INTRIICSTI interrupt processing.
6. When using the INTRIICNAKI interrupt, clear the RIICnSR2.NACKF flag in the INTRIICNAKI interrupt processing.
7. When using the INTRIICALI interrupt, clear the RIICnSR2.AL flag in the INTRIICALI interrupt processing.
8. When using the INTRIICTMOI interrupt, clear the RIICnSR2.TMOF flag in the INTRIICTMOI interrupt processing.

26.5 Operation

26.5.1 Communication Data Format

The I²C bus format consists of 8-bit data and 1-bit acknowledge (one frame). After a start condition or restart condition is issued, the master device sends the slave address and data direction in the first frame. The specified slave is valid until a stop condition is issued or a new slave is specified by a restart condition.

Figure 26.3 shows the I²C bus format, and **Figure 26.4** shows the I²C bus timing.

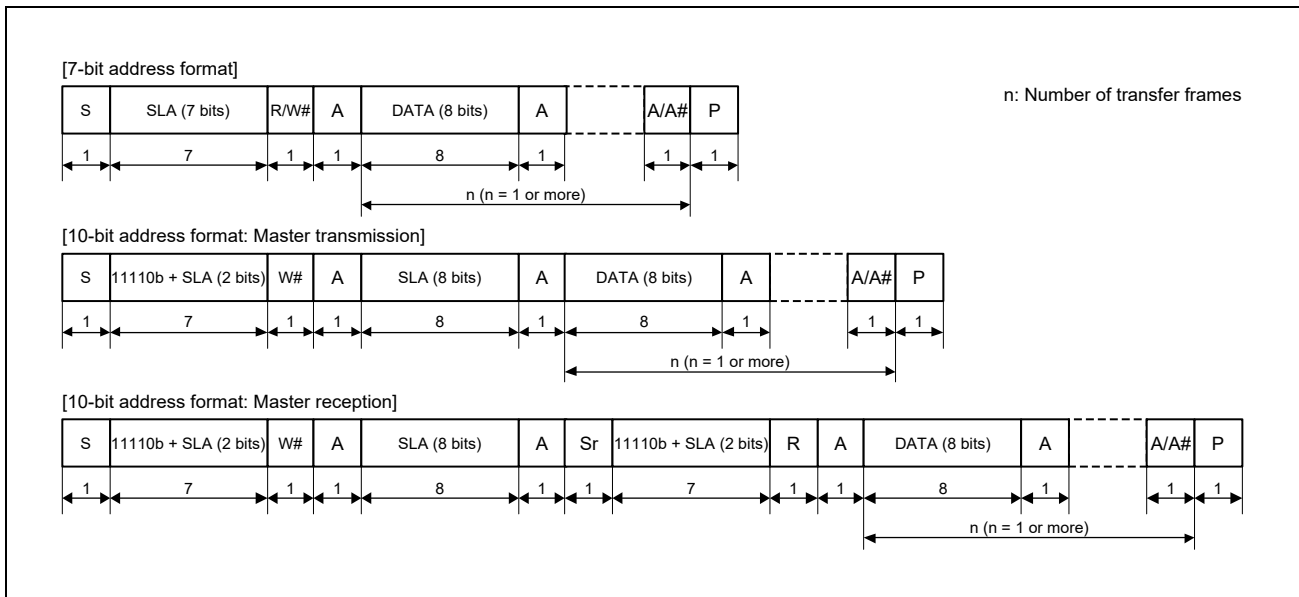
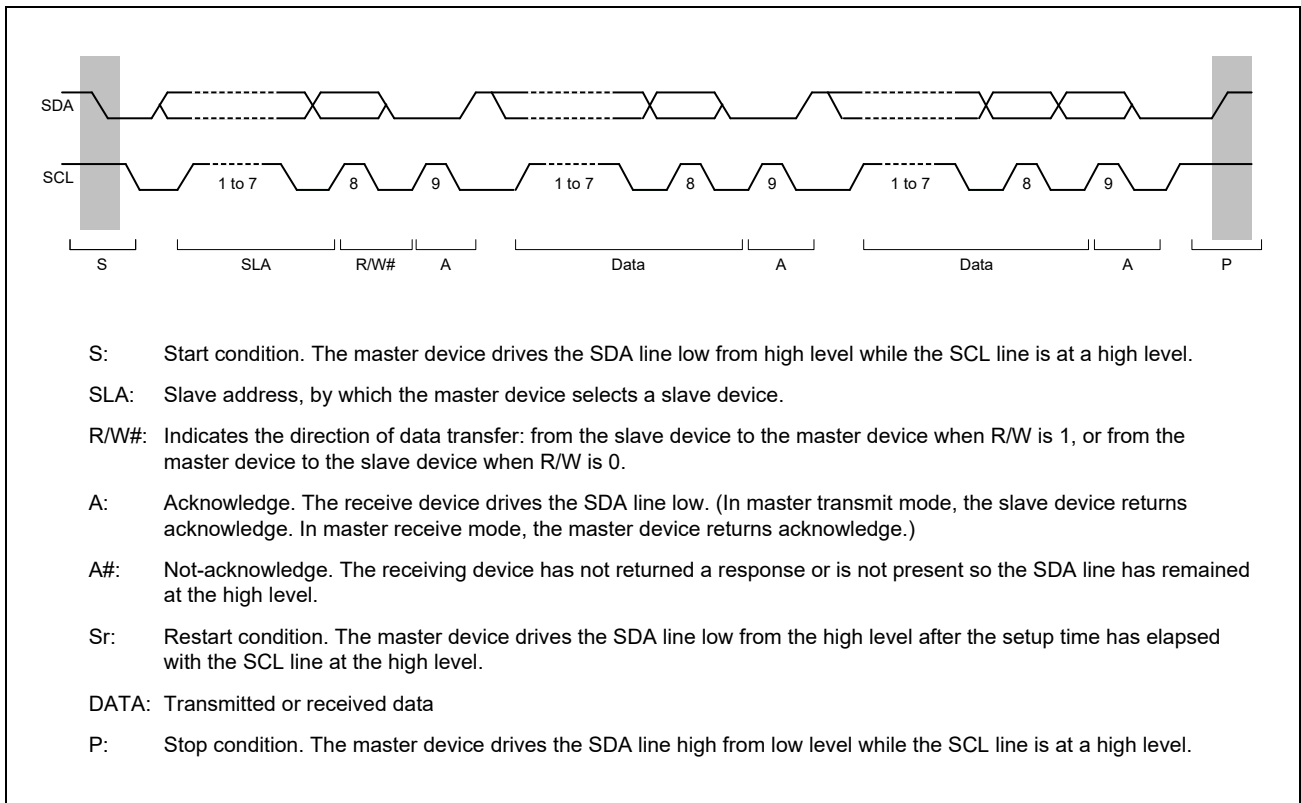

Figure 26.3 I²C Bus Format

Figure 26.4 I²C Bus Timing (SLA = 7 Bits)

26.5.2 Initial Settings

Before starting data transmission and reception, initialize the RIIC according to the procedure in **Figure 26.5**.

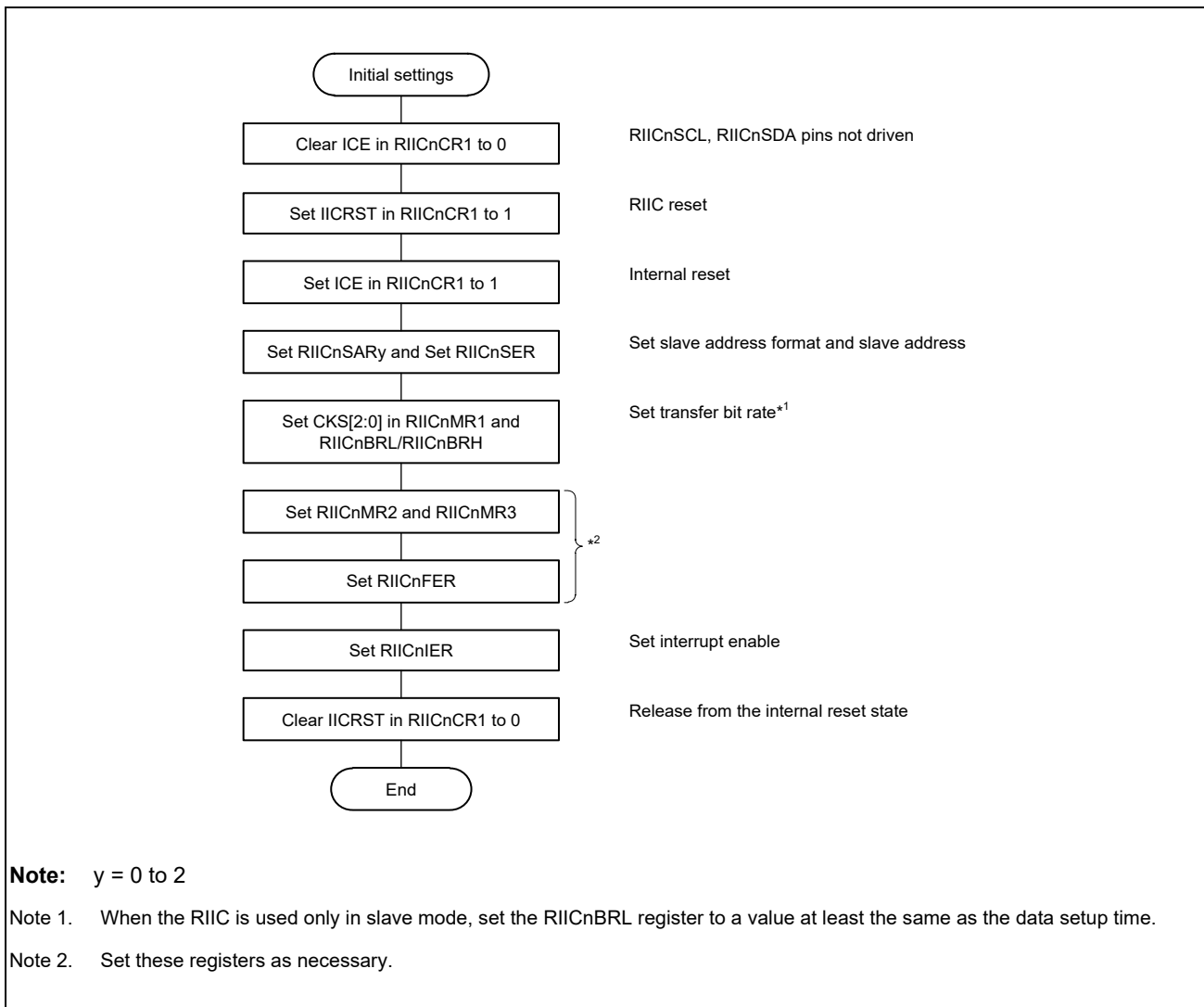

Figure 26.5 Example of RIIC Initialization Flowchart

26.5.3 Master Transmit Operation

In master transmit operation, the RIIC outputs the SCL (clock) and transmitted data signals as the master device, and the slave device returns acknowledgements. **Figure 26.6** shows an example of usage of master transmission and **Figure 26.7** to **Figure 26.9** show the timing of operations in master transmission.

The following describes the procedure and operations for master transmission.

- (1) Set the RIICnCR1.IICRST bit to 1 (RIIC reset) and then set the RIICnCR1.ICE bit to 1 (internal reset) with the RIICnCR1.ICE bit cleared to 0 (RIICnSCL and RIICnSDA pins not driven). This initializes the internal state and the various flags of RIICnSR1. After that, set registers RIICnSARy, RIICnSER, RIICnMR1, RIICnBRH, and RIICnBRL (y = 0 to 2), and set the other registers as necessary (for initial settings of the RIIC, see **Figure 26.5**). When the necessary register settings have been completed, set the RIICnCR1.IICRST bit to 0 (for release from the reset state). This step is not necessary if initialization of the RIIC has already been completed.
- (2) Read the RIICnCR2.BBSY flag to check that the bus is open, and then set the RIICnCR2.ST bit to 1 (start condition issuance request). Upon receiving the request, the RIIC issues a start condition. At the same time, the BBSY flag and the RIICnSR2.START flag are automatically set to 1 and the ST bit is automatically cleared to 0. At this time, if the start condition is detected and the internal levels for the SDA output state and the levels on the SDA line have matched while the ST bit is 1, the RIIC recognizes that issuing of the start condition as requested by the ST bit has been successfully completed, and the RIICnCR2.MST and TRS bits are automatically set to 1, placing the RIIC in master transmit mode. The RIICnSR2.TDRE flag is also automatically set to 1 in response to setting of the TRS bit to 1.
- (3) Check that the RIICnSR2.TDRE flag is 1, and then write the value for transmission (the slave address and the R/W# bit) to RIICnDRT. Once the data for transmission are written to RIICnDRT, the TDRE flag is automatically cleared to 0, the data are transferred from RIICnDRT to RIICnDRS, and the TDRE flag is again set to 1. After the byte containing the slave address and R/W# bit has been transmitted, the value of the TRS bit is automatically updated to select master transmit or master receive mode in accord with the value of the transmitted R/W# bit. If the value of the R/W# bit was 0, the RIIC continues in master transmit mode.

Since the RIICnSR2.NACKF flag being 1 at this time indicates that no slave device recognized the address or there was an error in communications, write 1 to the RIICnCR2.SP bit to issue a stop condition.

For data transmission with an address in the 10-bit format, start by writing 1111 0b, the two higher-order bits of the slave address, and W# to RIICnDRT as the first address transmission. Then, as the second address transmission, write the eight lower-order bits of the slave address to RIICnDRT.

- (4) After confirming that the RIICnSR2.TDRE flag is 1, write the data for transmission to the RIICnDRT register. The RIIC automatically holds the SCL line low until the data for transmission are ready or a stop condition is issued.
- (5) After the last byte of the data to be transmitted is written to the RIICnDRT register, wait until the value of the RIICnSR2.TEND flag returns to 1, and then set the RIICnCR2.SP bit to 1 (stop condition issuance request). Upon receiving a stop condition issuance request, the RIIC issues the stop condition.
- (6) Upon detecting the stop condition, the RIIC automatically clears the RIICnCR2.MST and TRS bits to 00b and enters slave receive mode. Furthermore, it automatically clears the RIICnSR2.TDRE and TEND flags to 0, and sets the RIICnSR2.STOP flag in to 1.
- (7) Clear the RIICnSR2.NACKF and STOP flags to 0.

CAUTION

Operations for transfer start if the RIICnSR2.NACKF flag is cleared to 0 before RIICnSR2.STOP is set to 1. Be sure to confirm that RIICnSR2.STOP is set to 1 before clearing RIICnSR2.NACKF to 0. In particular, when the NACK receive interrupt (INTRIICNAKI) is in use, take care not to clear the NACKF flag to 0 before the STOP flag is set to 1 during interrupt processing.

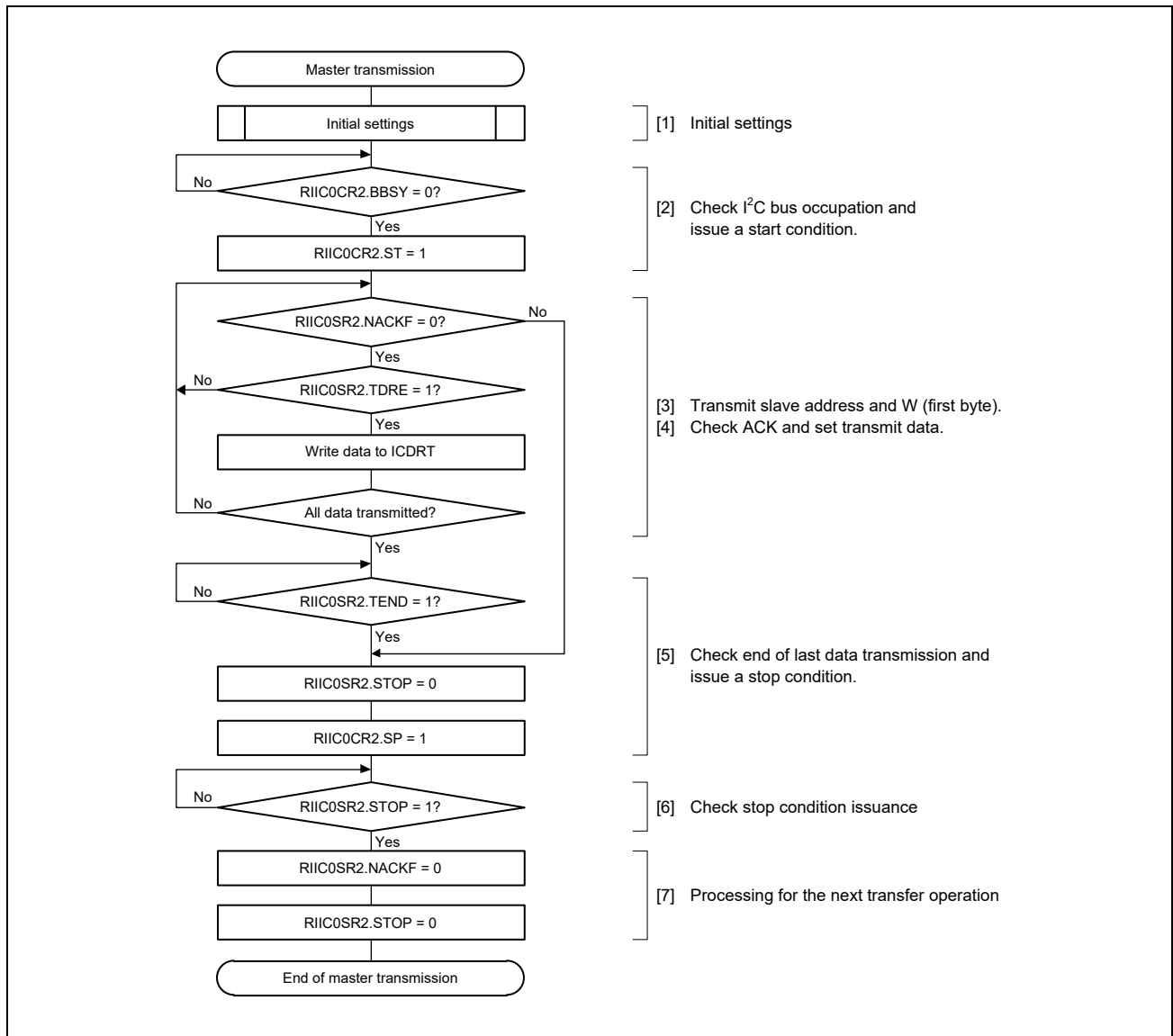

Figure 26.6 Example of Master Transmission Flowchart

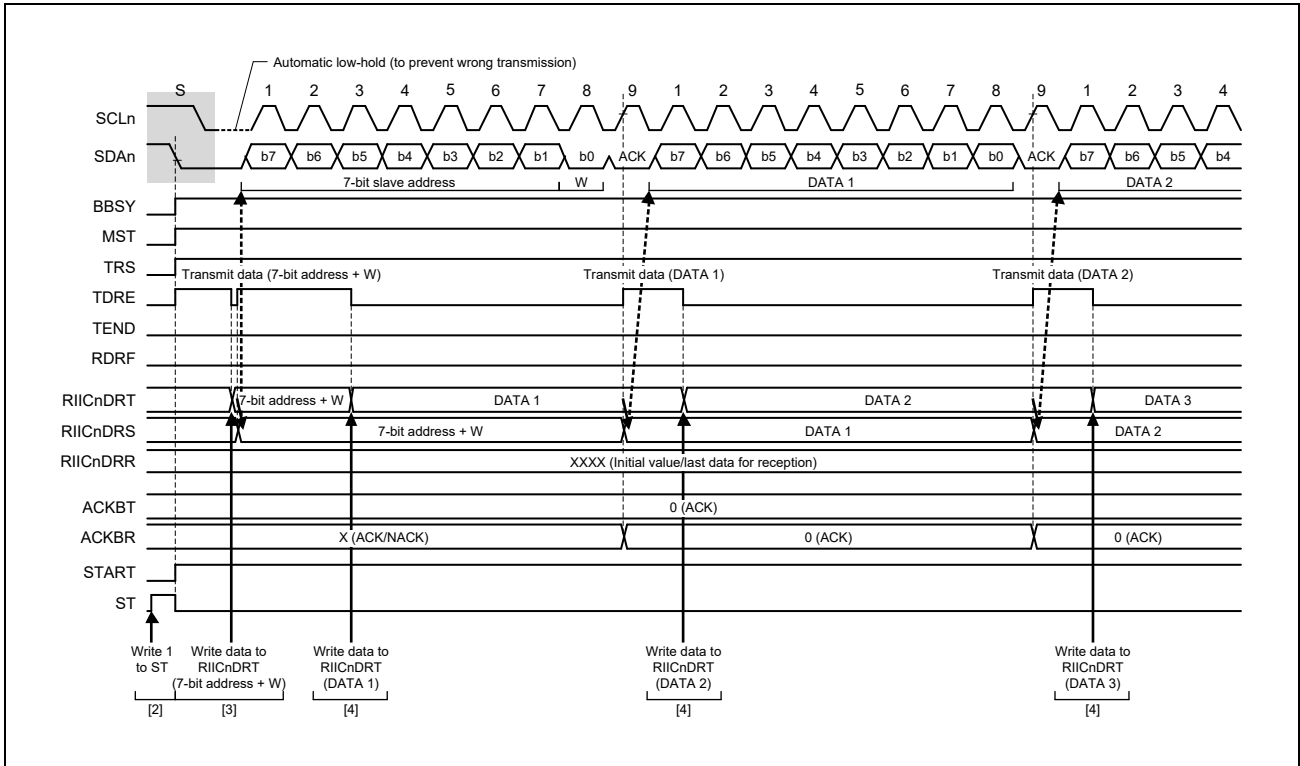

Figure 26.7 Master Transmit Operation Timing (1) (7-Bit Address Format)

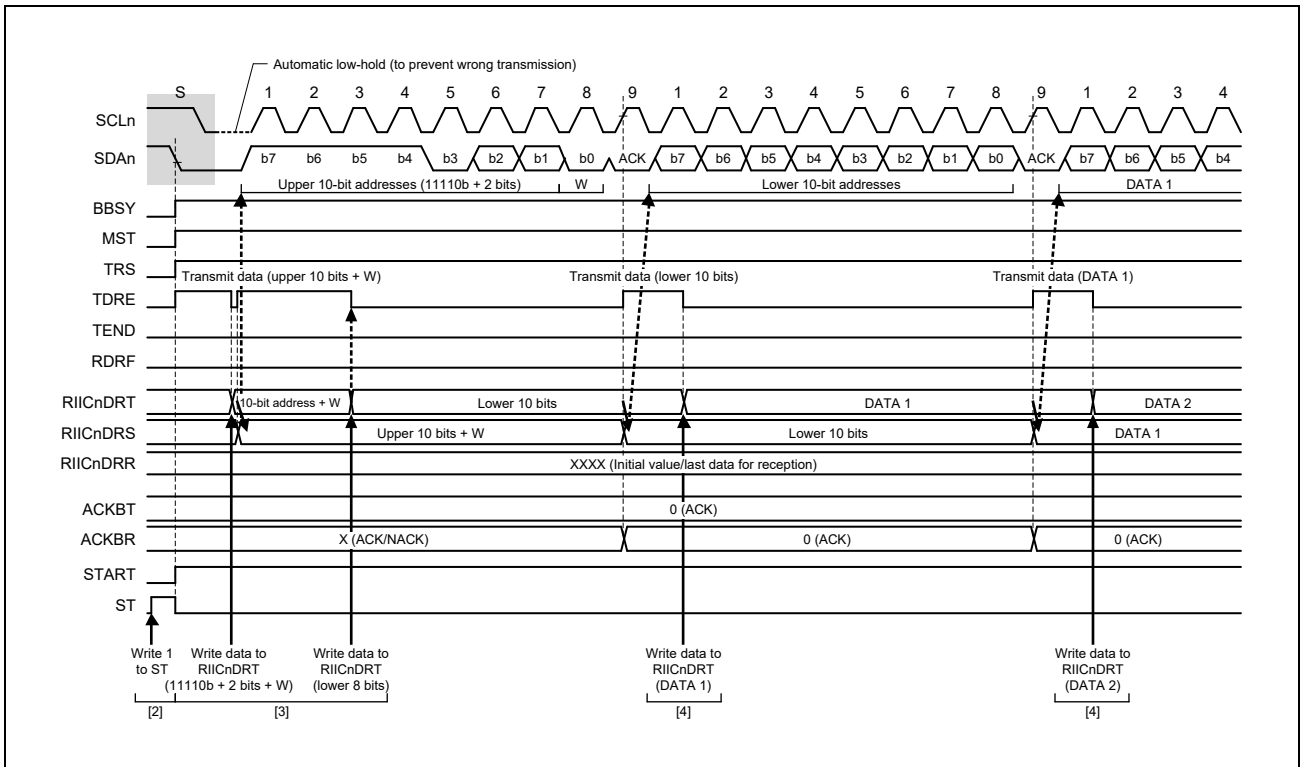

Figure 26.8 Master Transmit Operation Timing (2) (10-Bit Address Format)

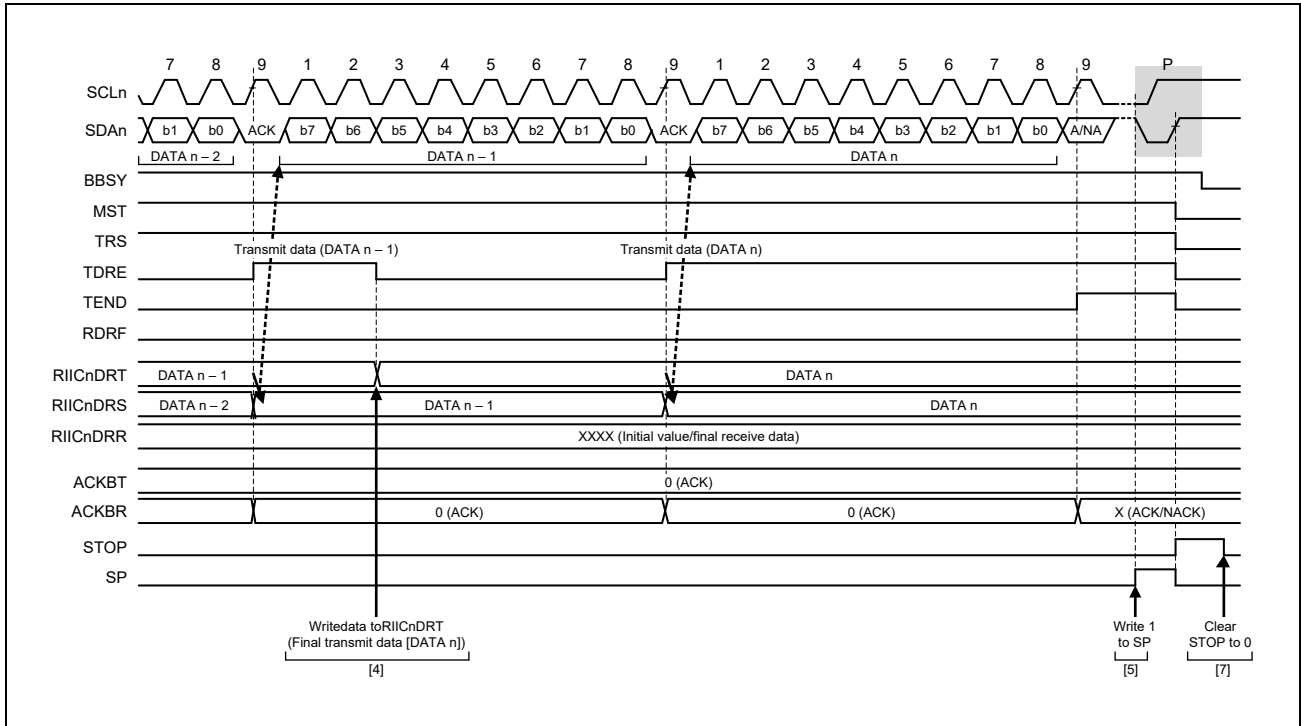

Figure 26.9 Master Transmit Operation Timing (3)

26.5.4 Master Receive Operation

In master receive operation, the RIIC as a master device outputs the SCL (clock) signal, receives data from the slave device, and returns acknowledgements. Since the RIIC must start by sending a slave address to the corresponding slave device, this part of the procedure is performed in master transmit mode, but the subsequent steps are in master receive mode.

Figure 26.10 shows an example of usage for the master reception of 3 or more bytes (7-bit address format), **Figure 26.14** shows an example of usage for the master reception of 1 or 2 bytes (7-bit address format), and **Figure 26.11** to **Figure 26.13** show the timing of operations in master reception.

The following describes the procedure and operations for master reception.

- (1) Set the RIICnCR1.IICRST bit to 1 (RIIC reset) and then set the RIICnCR1.ICE bit to 1 (internal reset) with the RIICnCR1.ICE bit cleared to 0 (RIICnSCL and RIICnSDA pins not driven). This initializes the internal state and the various flags of RIICnSR1. After that, set registers RIICnSARy, RIICnSER, RIICnMR1, RIICnBRH, and RIICnBRL (y = 0 to 2), and set the other registers as necessary (for initial settings of the RIIC, see **Figure 26.5**). When the necessary register settings have been completed, set the RIICnCR1.IICRST bit to 0 (for release from the reset state). This step is not necessary if initialization of the RIIC has already been completed.
- (2) Read the RIICnCR2.BBSY flag to check that the bus is open, and then set the RIICnCR2.ST bit to 1 (start condition issuance request). Upon receiving the request, the RIIC issues a start condition. When the RIIC detects the start condition, the BBSY flag and the RIICnSR2.START flag are automatically set to 1 and the ST bit is automatically cleared to 0. At this time, if the start condition is detected and the levels for the SDA output and the levels on the SDA line have matched while the ST bit is 1, the RIIC recognizes that issuing of the start condition as requested by the ST bit has been successfully completed, and the RIICnCR2.MST and TRS bits are automatically set to 1, placing the RIIC in master transmit mode. The RIICnSR2.TDRE flag is also automatically set to 1 in response to setting of the TRS bit to 1.
- (3) Check that the RIICnSR2.TDRE flag is 1, and then write the value for transmission (the first byte indicates the slave address and value of the R/W# bit) to RIICnDRT. Once the data for transmission are written to RIICnDRT, the TDRE flag is automatically cleared to 0, the data are transferred from RIICnDRT to RIICnDRS, and the TDRE flag is again set to 1. Once the byte containing the slave address and R/W# bit has been transmitted, the value of the RIICnCR2.TRS bit is automatically updated to select transmit or receive mode in accord with the value of the transmitted R/W# bit. If the value of the R/W# bit was 1, the RIICnCR2.TRS bit is cleared to 0 on the rising edge of the ninth cycle of SCL (the clock signal), placing the RIIC in master receive mode. At this time, the TDRE flag is automatically cleared to 0 and the RIICnSR2.RDRF flag is automatically set to 1.

Since the RIICnSR2.NACKF flag being 1 at this time indicates that no slave device recognized the address or there was an error in communications, write 1 to the RIICnCR2.SP bit to issue a stop condition.

For master reception from a device with a 10-bit address, start by using master transmission to issue the 10-bit address, and then issue a restart condition. After that, transmitting 1111 0b, the two higher-order bits of the slave address, and the R bit places the RIIC in master receive mode.

- (4) Dummy read RIICnDRR after confirming that the RIICnSR2.RDRF flag is 1; this makes the RIIC start output of the SCL (clock) signal and start data reception.
- (5) After 1 byte of data has been received, the RIICnSR2.RDRF flag is set to 1 on the rising edge of the eighth or ninth cycle of SCL clock (the clock signal) as selected by the RIICnMR3.RDRFS bit. Reading out RIICnDRR at this time will produce the received data, and the RDRF flag is automatically cleared to 0 at the same time. Furthermore, the value of the acknowledgement field received during the ninth cycle of SCL clock is returned as the value set in the RIICnMR3.ACKBT bit. Furthermore, if the next byte to be received is the next to last byte, set the RIICnMR3.WAIT bit to 1 (for wait insertion) before reading the RIICnDRR (containing the second byte from last). As well as enabling NACK output even in the case of delays in processing to set the RIICnMR3.ACKBT bit

to 1 (NACK) in step (6), due to other interrupts, etc., this fixes the SCL line to the low level on the rising edge of the ninth clock cycle in reception of the last byte, so the state is such that issuing a stop condition is possible.

- (6) When the RIICnMR3.RDRFS bit is 0 and the slave device must be notified that it is to end transfer for data reception after transfer of the next (final) byte, set the RIICnMR3.ACKBT bit to 1 (NACK).
- (7) After reading out the byte before last from the RIICnDRR register, if the value of the RIICnSR2.RDRF flag is confirmed to be 1, write 1 to the RIICnCR2.SP bit (stop condition issuance request) and then read the last byte from RIICnDRR. When RIICnDRR is read, the RIIC is released from the wait state and issues the stop condition after low-level output in the ninth clock cycle is completed or the SCL line is released from the low-hold state.
- (8) Upon detecting the stop condition, the RIIC automatically clears the RIICnCR2.MST and TRS bits to 00b and enters slave receive mode. Furthermore, detection of the stop condition leads to setting of the RIICnSR2.STOP flag to 1.
- (9) After checking that the RIICnSR2.STOP flag is 1, clear the RIICnSR2.NACKF and STOP flags to 0 for the next transfer operation.

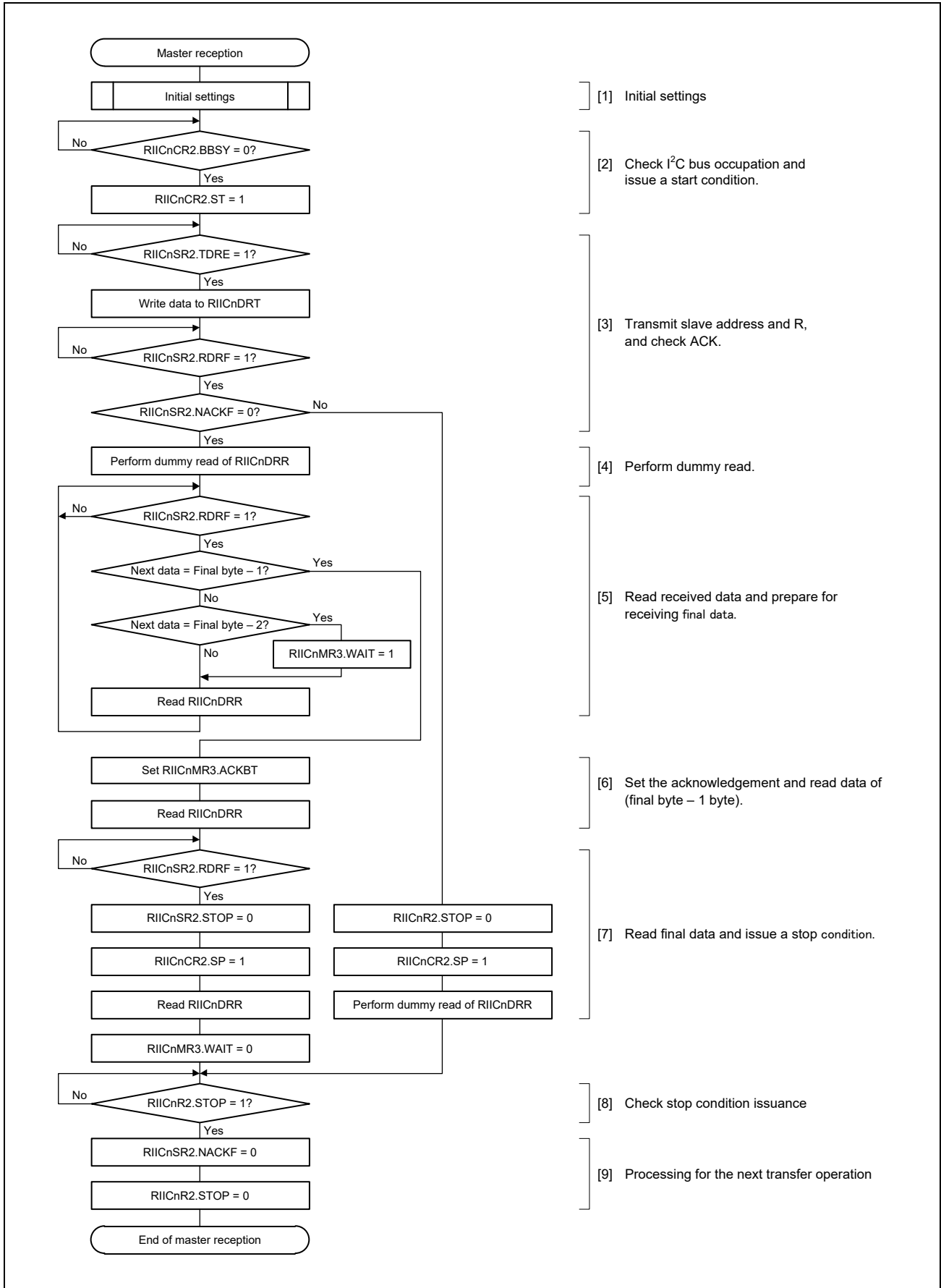

Figure 26.10 Example Flowchart for the Master Reception of 3 or More Bytes (7-Bit Address Format)

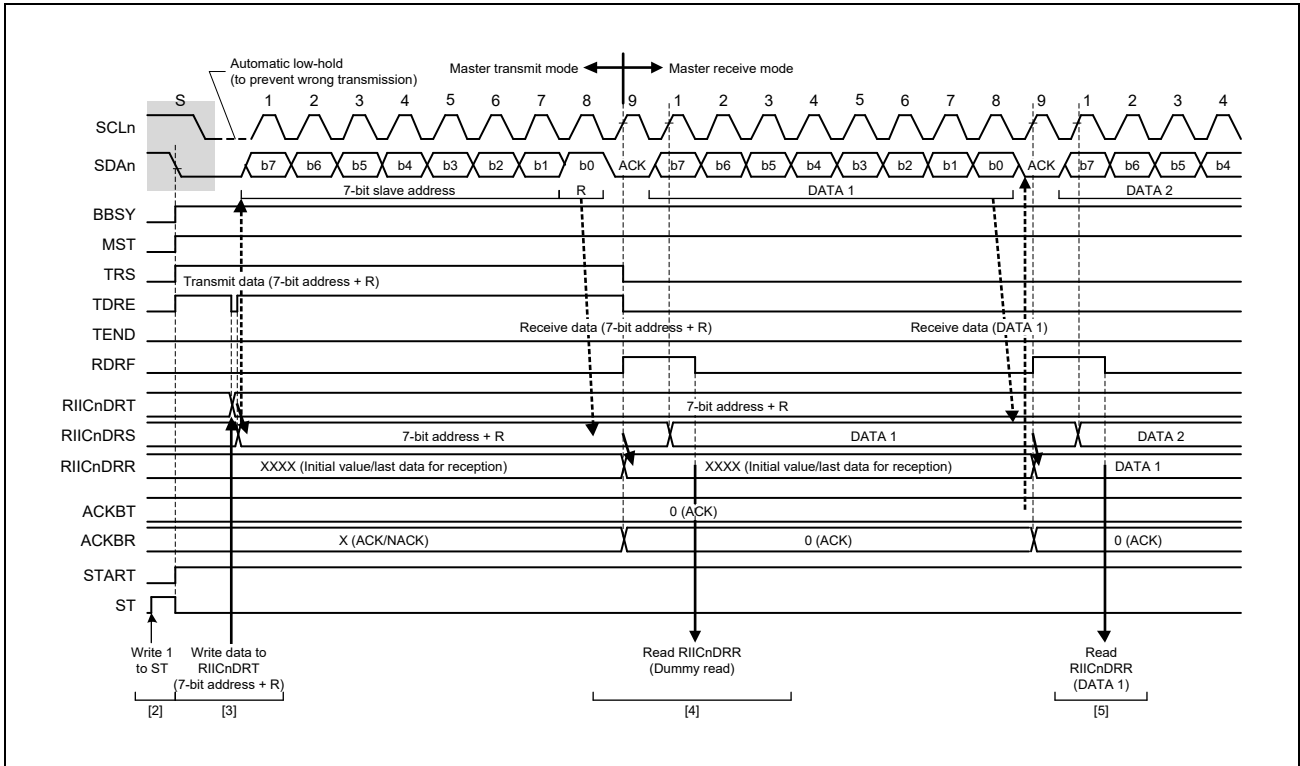

Figure 26.11 Master Receive Operation Timing (1) (7-Bit Address Format, when RDRFS = 0)

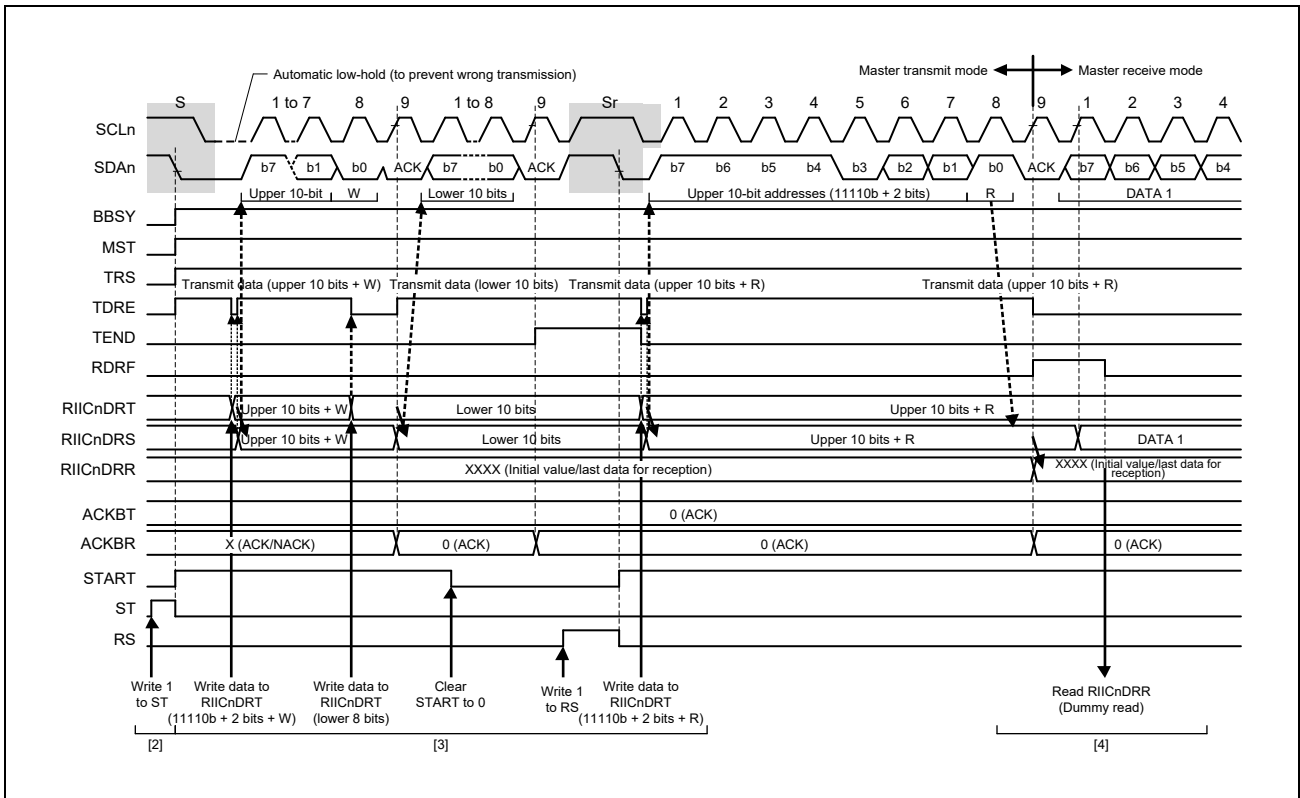

Figure 26.12 Master Receive Operation Timing (2) (10-Bit Address Format, when RDRFS = 0)

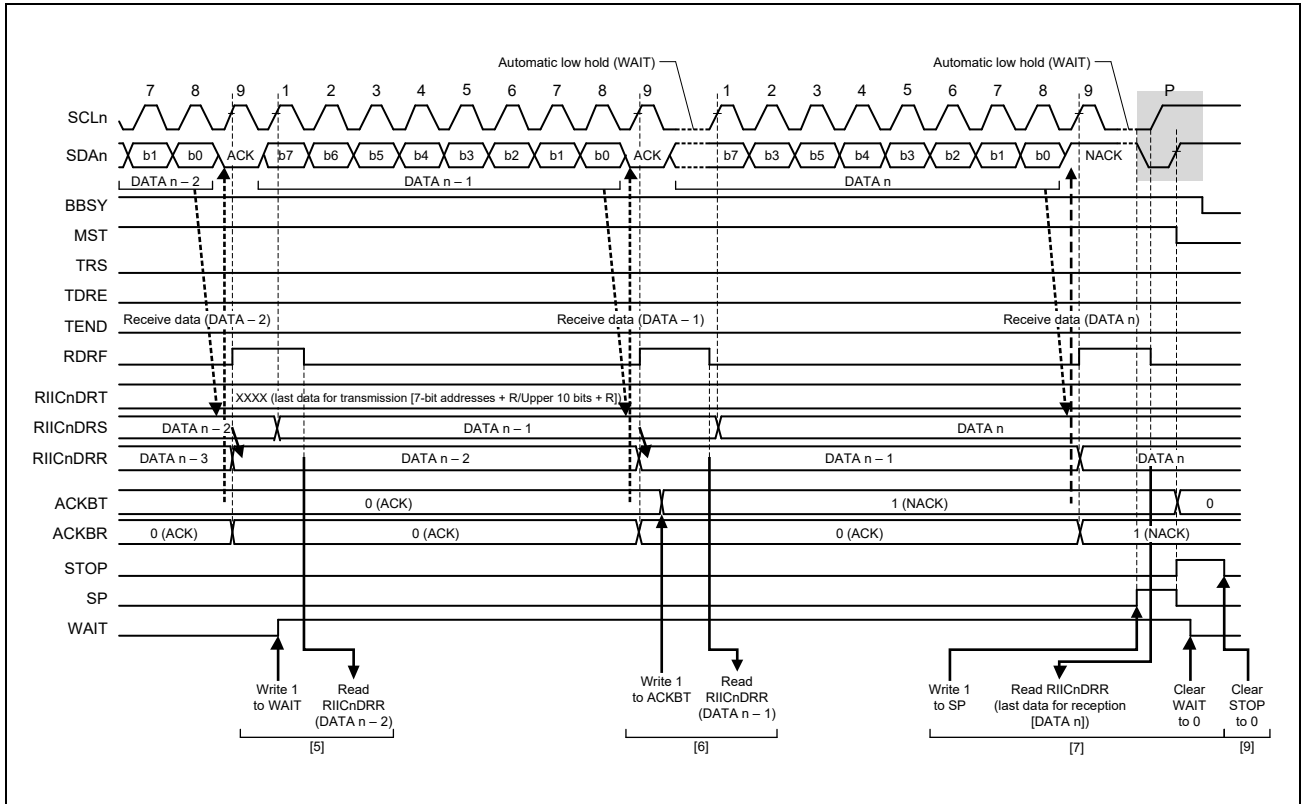

Figure 26.13 Master Receive Operation Timing (3) (when RDRFS = 0)

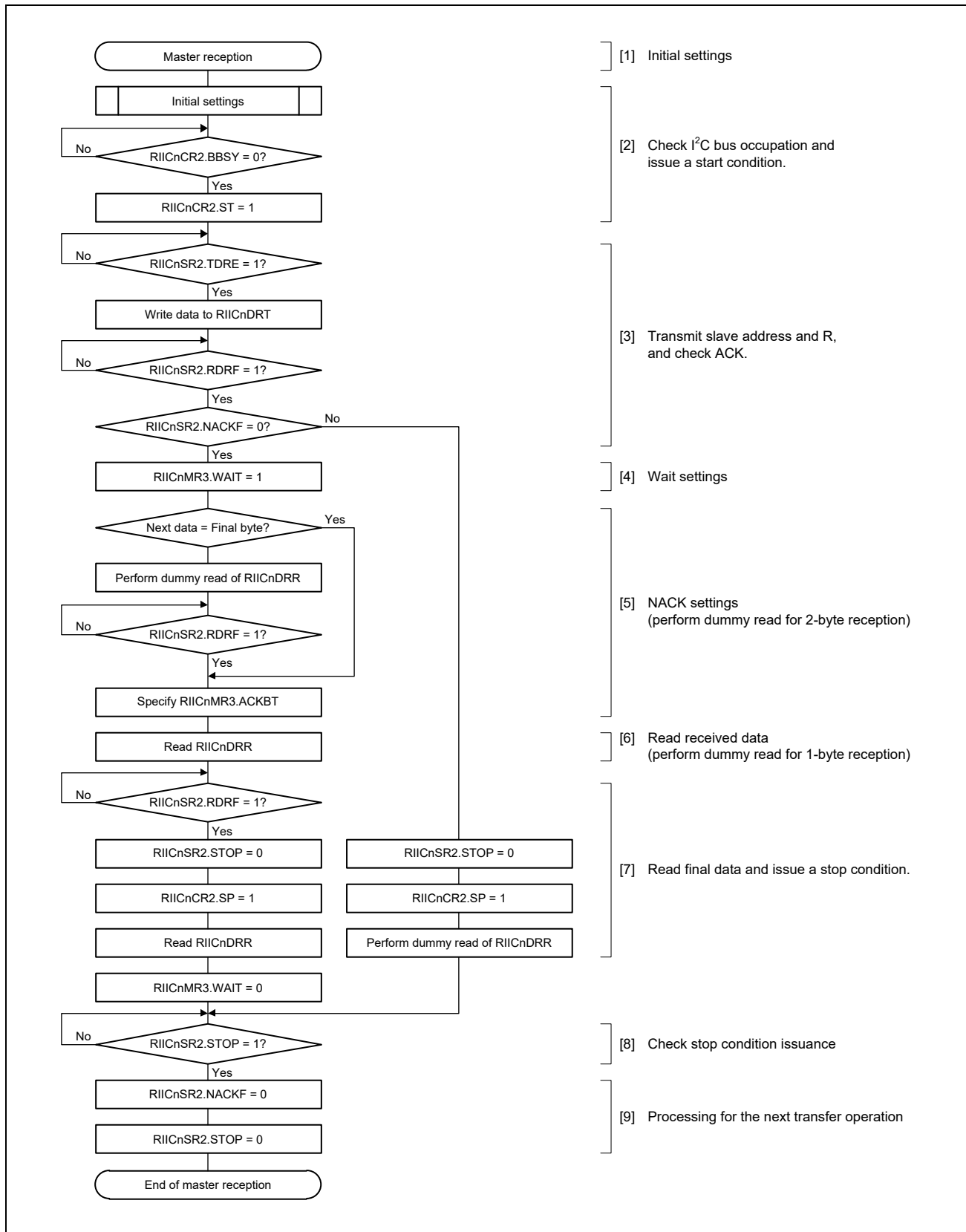

Figure 26.14 Example Flowchart for the Master Reception of 1 or 2 Bytes (7-Bit Address Format)

26.5.5 Slave Transmit Operation

In slave transmit operation, the master device outputs the SCL (clock) signal, the RIIC transmits data as a slave device, and the master device returns acknowledgements.

Figure 26.15 shows an example of usage of slave transmission and **Figure 26.16** and **Figure 26.17** show the timing of operations in slave transmission.

The following describes the procedure and operations for slave transmission.

- (1) Follow the procedure in **Figure 26.5** to make initial settings for the RIIC. This step is not necessary if initialization of the RIIC has already been completed. After initial settings, the RIIC will stay in the standby state until it receives a slave address that it matches.
- (2) After receiving a matching slave address, the RIIC sets one of the corresponding bits RIICnSR1.HOA, GCA, and AAS_y ($y = 0$ to 2) to 1 on the rising edge of the ninth cycle of SCL clock (the clock signal) and outputs the value set in the RIICnMR3.ACKBT bit to the acknowledge bit on the ninth cycle of SCL clock. If the value of the R/W# bit that was also received at this time is 1, the RIIC automatically places itself in slave transmit mode by setting both the RIICnCR2.TRS bit and the RIICnSR2.TDRE flag to 1.
- (3) After the RIICnSR2.TEND flag is confirmed to be 1, write the data for transmission to the RIICnDRT register. At this time, if the RIIC receives no acknowledge from the master device (receives an NACK signal) while the RIICnFER.NACKE bit is 1, the RIIC suspends transfer of the next data.
- (4) Wait until the RIICnSR2.TEND flag is set to 1 while the RIICnSR2.TDRE flag is 1, after the RIICnSR2.NACKF flag is set to 1 or the last byte for transmission is written to the RIICnDRT register. When the RIICnSR2.NACKF flag or the TEND flag is 1, the RIIC drives the SCL line low on the ninth falling edge of SCL clock.
- (5) When the RIICnSR2.NACKF flag or the RIICnSR2.TEND flag is 1, dummy read RIICnDRR to complete the processing. This releases the SCL line.
- (6) Upon detecting the stop condition, the RIIC automatically clears bits RIICnSR1.HOA, GCA, and AAS_y ($y = 0$ to 2), flags RIICnSR2.TDRE and TEND, and the RIICnCR2.TRS bit to 0, and enters slave receive mode.
- (7) Clear the RIICnSR2.NACKF and STOP flags to 0.

CAUTION

Operations for transfer start if the RIICnSR2.NACKF flag is cleared to 0 before RIICnSR2.STOP is set to 1. Be sure to confirm that RIICnSR2.STOP is set to 1 before clearing RIICnSR2.NACKF to 0. In particular, when the NACK receive interrupt (INTRIICNAKI) is in use, take care not to clear the NACKF flag to 0 before the STOP flag is set to 1 during interrupt processing.

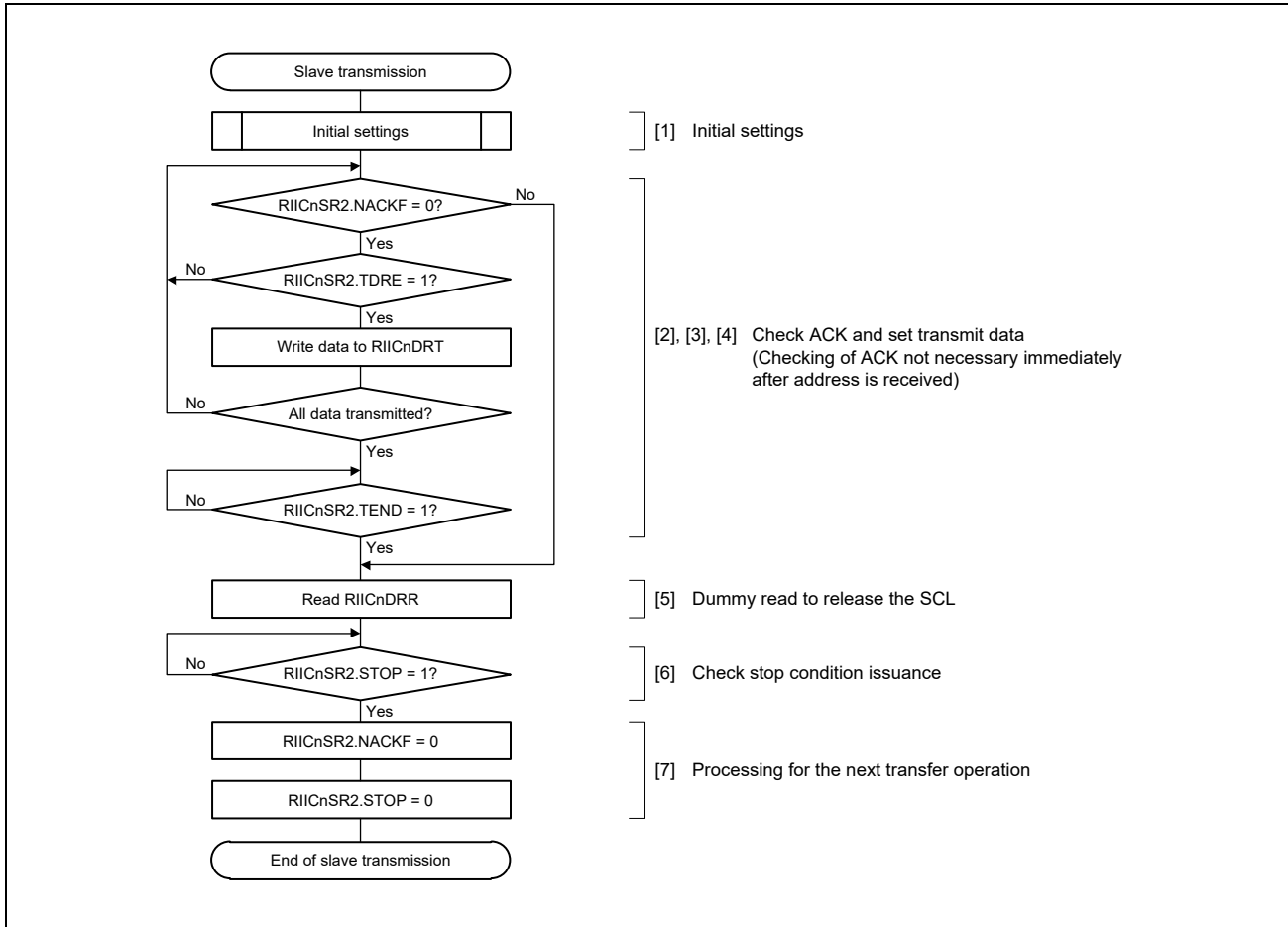

Figure 26.15 Example of Slave Transmission Flowchart

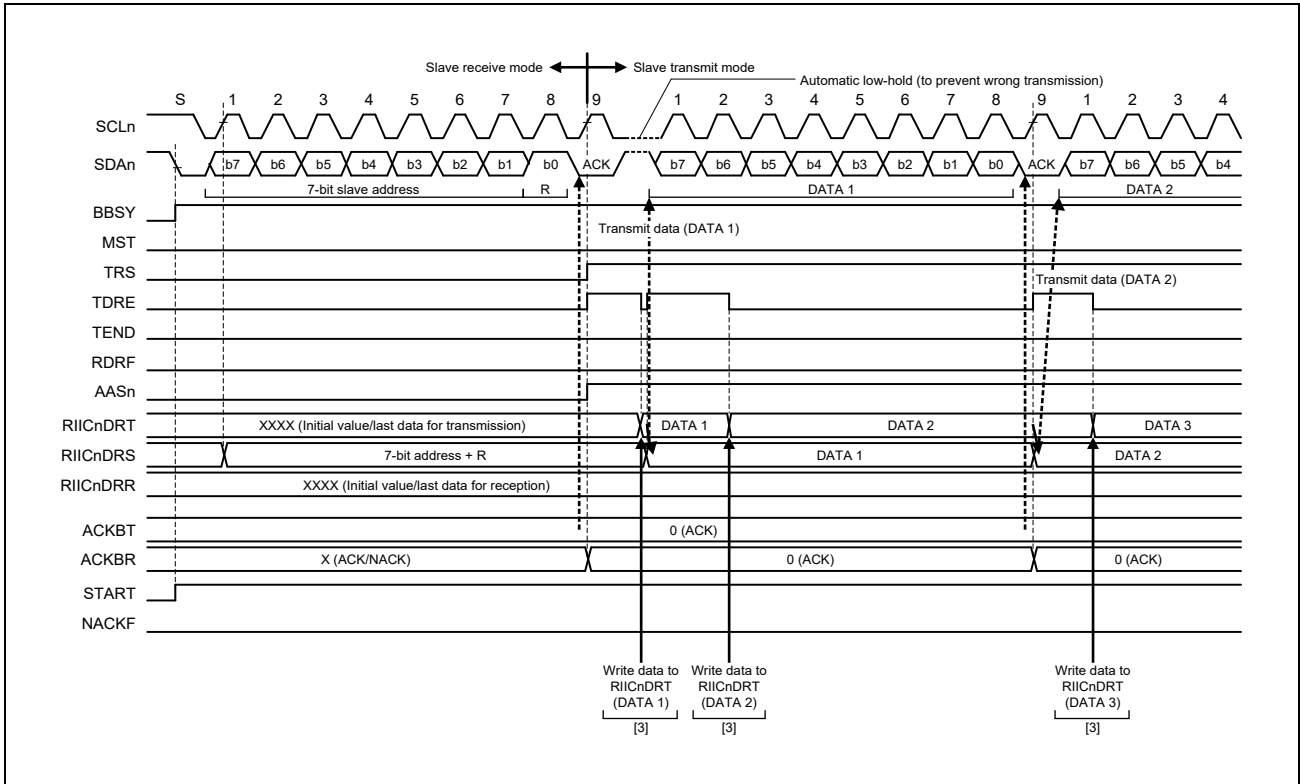

Figure 26.16 Slave Transmit Operation Timing (1) (7-Bit Address Format)

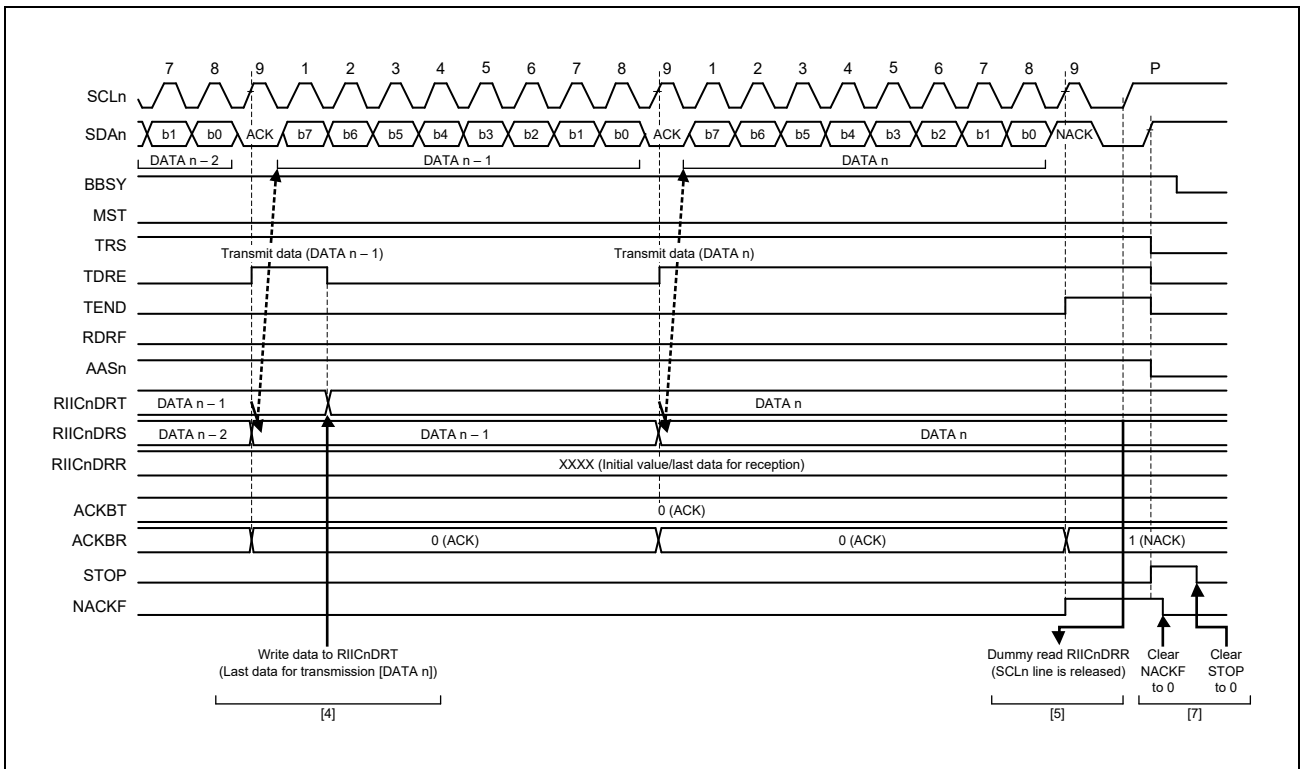

Figure 26.17 Slave Transmit Operation Timing (2)

26.5.6 Slave Receive Operation

In slave receive operation, the master device outputs the SCL clock and transmit data, and the RIIC returns acknowledgements as a slave device.

Figure 26.18 shows an example of usage of slave reception and **Figure 26.19** and **Figure 26.20** show the timing of operations in slave reception.

The following describes the procedure and operations for slave reception.

- (1) Follow the procedure in **Figure 26.5** to make initial settings for the RIIC. This step is not necessary if initialization of the RIIC has already been completed. After initial settings, the RIIC will stay in the standby state until it receives a slave address that it matches.
- (2) After receiving a matching slave address, the RIIC sets one of the corresponding bits RIICnSR1.HOA, GCA, and AASy (y = 0 to 2) to 1 on the rising edge of the ninth cycle of SCL clock (the clock signal) and outputs the value set in the RIICnMR3.ACKBT bit to the acknowledge bit on the ninth cycle of SCL clock. If the value of the R/W# bit that was also received at this time is 0, the RIIC continues to place itself in slave receive mode and sets the RIICnSR2.RDRF flag to 1.
- (3) After the RIICnSR2.STOP flag is confirmed to be 0 and the RIICnSR2.RDRF flag to be 1, dummy read RIICnDRR (the dummy value consists of the slave address and R/W# bit when the 7-bit address format is selected, or the lower eight bits when the 10-bit address format is selected).
- (4) When RIICnDRR is read, the RIIC automatically clears the RIICnSR2.RDRF flag to 0. If reading of RIICnDRR is delayed and a next byte is received while the RDRF flag is still set to 1, the RIIC holds the SCL line low from one SCL cycle before the timing with which RDRF should be set. In this case, reading RIICnDRR releases the SCL line from being held at the low level.

When the RIICnSR2.STOP flag is 1 and the RIICnSR2.RDRF flag is also 1, read RIICnDRR until all the data is completely received.

- (5) Upon detecting the stop condition, the RIIC automatically clears bits RIICnSR1.HOA, GCA, and AASy (y = 0 to 2) to 0.
- (6) After checking that the RIICnSR2.STOP flag is 1, clear the RIICnSR2.STOP flag to 0 for the next transfer operation.

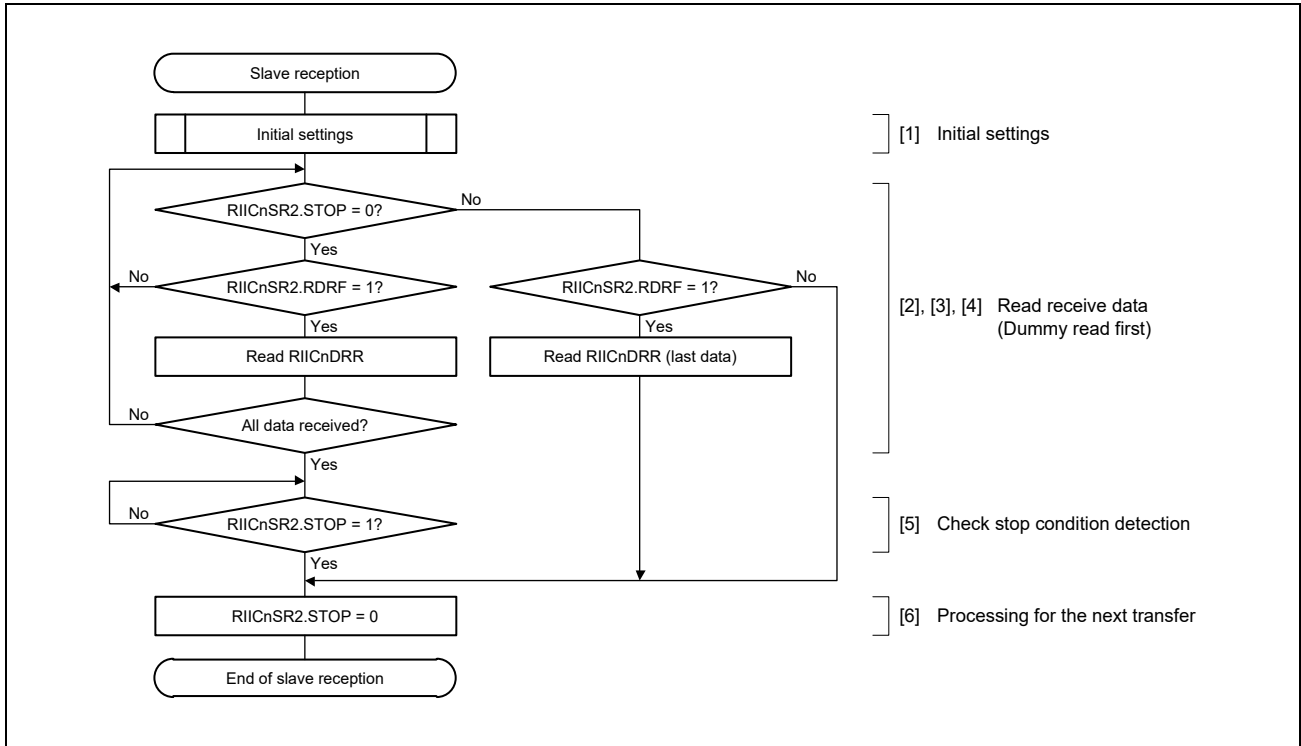

Figure 26.18 Example of Slave Reception Flowchart

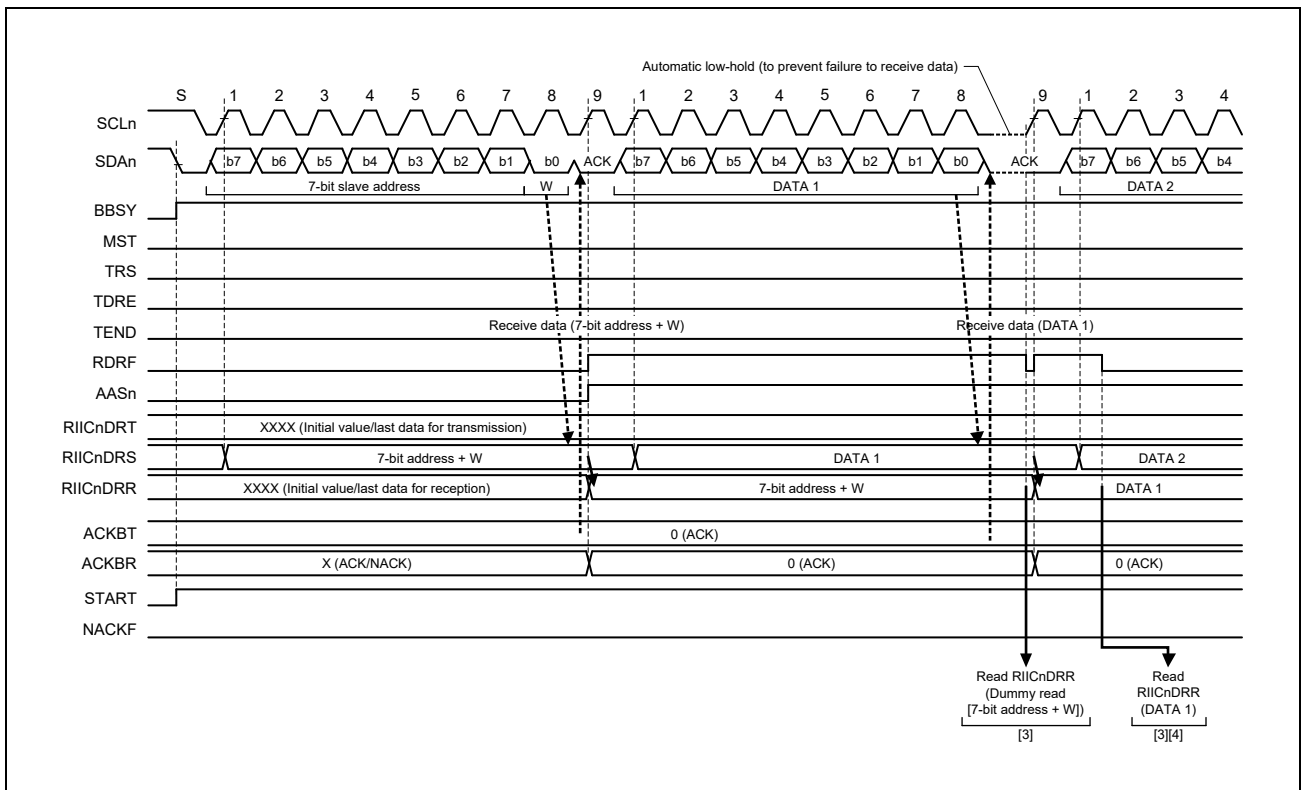

Figure 26.19 Slave Receive Operation Timing (1) (7-Bit Address Format, when RDRFS = 0)

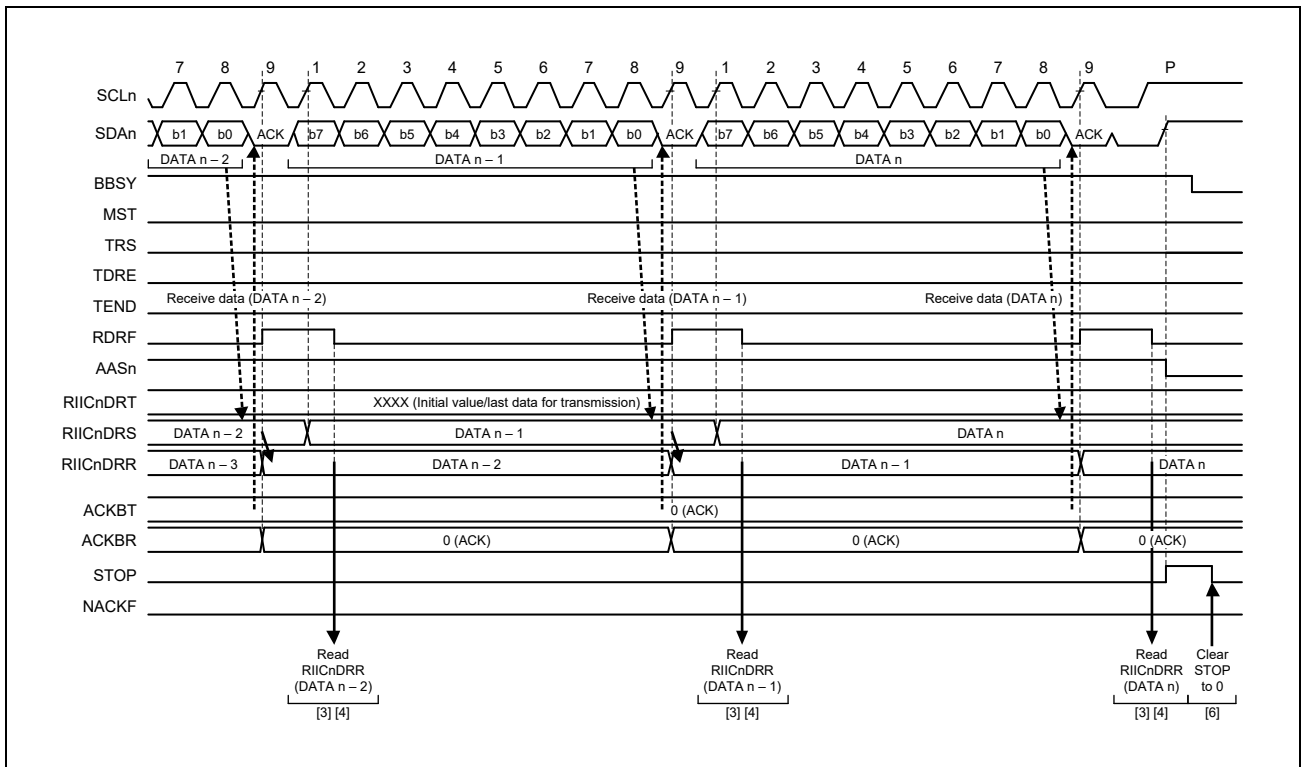

Figure 26.20 Slave Receive Operation Timing (2) (when RDRFS = 0)

26.6 SCL Synchronization Circuit

In generation of the SCL (clock) signal, the RIIC starts counting out the value for width at high level specified in RIICnBRH when it detects a rising edge on the SCL line and drives the SCL line low once counting of the width at high level is complete. When the RIIC detects the falling edge of the SCL line, it starts counting out the width at low level period specified in RIICnBRL, and then stops driving the SCL line (releases the line) once counting of the width at low level is complete. The SCL (clock) signal is thus generated.

If multiple master devices are connected to the I²C bus, a collision of SCL signals may arise due to contention with another master device. In such cases, the master devices have to synchronize their SCL signals. Since this synchronization of SCL signals must be bit by bit, the RIIC is equipped with a facility (the SCL synchronization circuit) to obtain bit-by-bit synchronization of the SCL clock signals by monitoring the SCL line during communication.

When the RIIC has detected a rising edge on the SCL line and thus started counting out the width at high level specified in RIICnBRH, and the level on the SCL line falls because an SCL signal is being generated by another master device, the RIIC stops counting when it detects the falling edge, drives the level on the SCL line low, and starts counting out the width at low level specified in RIICnBRL. When the RIIC finishes counting out the width at low level, it stops driving the SCL line to the low level (i.e. releases the line). At this time, if the width at low level of the SCL clock signal from the other master device is longer than the width at low level set in the RIIC, the width at low level of the SCL signal will be extended. Once the width at low level for the other master device has ended, the SCL signal rises because the SCL line has been released. When the RIIC finishes outputting the low-level period of the SCL clock, the SCL line is released and the SCL clock rises. That is, in cases of contention of SCL signals from more than one master, the width at high level of the SCL signal is synchronized with that of the clock having the narrower width, and the width at low level of the SCL signal is synchronized with that of the clock having the broader width. However, such synchronization of the SCL signal is only enabled when the RIICnFER.SCLE bit is set to 1.

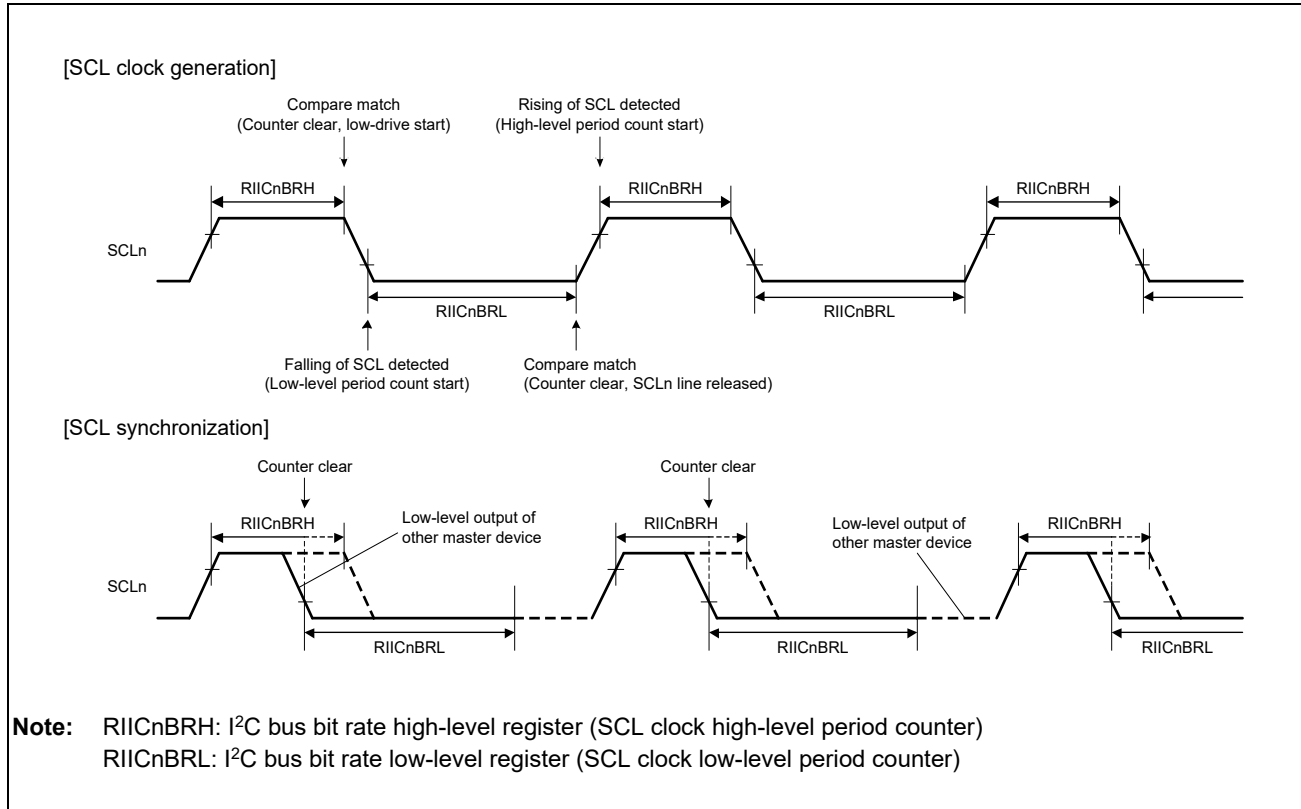

Figure 26.21 Generation and Synchronization of the SCL Signal from the RIIC

26.7 Facility for Delaying SDA Output

The RIIC module incorporates a facility for delaying output on the SDA line. The delay can be applied to all output (issuing of the start, restart, and stop conditions, data, and the ACK and NACK signals) on the SDA line.

With the SDA output delay facility, SDA output is delayed from detection of a falling edge of the SCL signal to ensure that the SDA signal is output within the interval over which the SCL (clock) signal is at the low level. Doing this leads to usage with the aim of preventing erroneous operation of communications devices, with the aim of satisfying the 300-ns (min.) data-hold time requirement of the SMBus specification.

The output delay facility is enabled by setting the RIICnMR2.SDDL[2:0] bits to any value other than 000b, and disabled by setting the same bits to 000b.

While the SDA output delay facility is enabled (i.e. while the SDDL[2:0] bits in IMCR2 are set to any value other than 000b), the RIICnMR2.DLCS bit selects the clock source for counting by the SDA output delay counter as the internal base clock (IIC ϕ) for the RIIC module or as a clock signal derived by dividing the frequency of the internal base clock by two (IIC ϕ /2). The counter counts the number of cycles set in the SDDL[2:0] bits in IMCR2. After counting of the set number of cycles of delay is completed, the RIIC module places the required output (start, restart, or stop condition, data, or an ACK or NACK signal) on the SDA line.

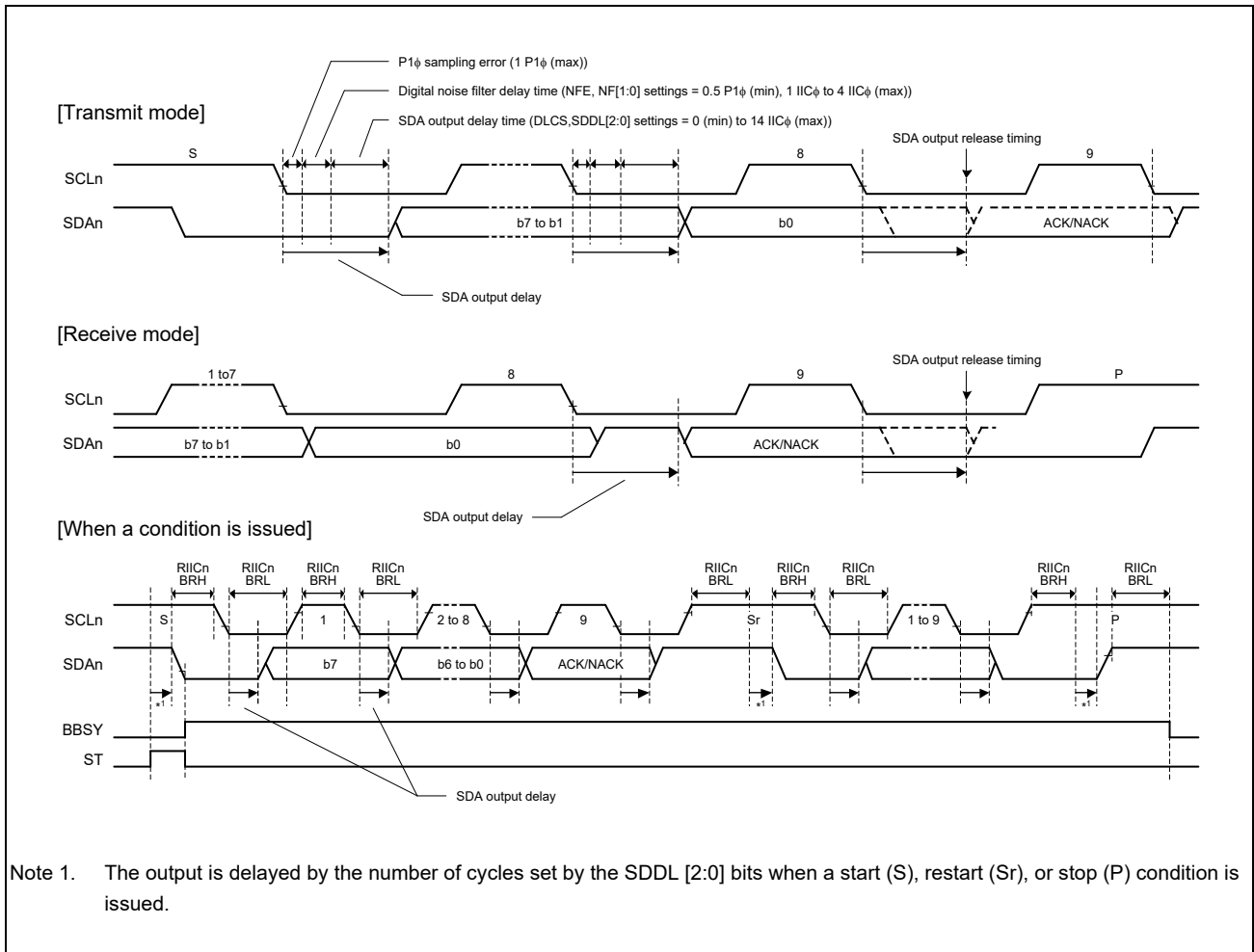

Figure 26.22 SDA Output Delay Facility

26.8 Digital Noise-Filter Circuits

Figure 26.23 is a block diagram of the digital noise-filter circuit. When the NFE bit in the RIICnFER register is set to 1, input to the RIICnSCL and RIICnSDA pins are conveyed to the internal circuitry through digital noise-filter circuits.

The on-chip digital noise-filter circuit of the RIIC consists of four flip-flop circuit stages connected in series and a match-detection circuit.

The number of effective stages in the digital noise filter is selected by the RIICnMR3.NF[1:0] bits. The selected number of effective stages determines the noise-filtering capability as a period from one to four IIC ϕ cycles.

The input signal to the RIICnSCL pin (or RIICnSDA pin) is sampled on falling edges of the IIC ϕ signal. When the input signal level matches the output level of the number of effective flip-flop circuit stages as selected by the RIICnMR3.NF[1:0] bits, the signal level is conveyed to the subsequent stage. If the signal levels do not match, the previous value is retained.

If the ratio between P0 ϕ and IIC ϕ is small when the RIICnMR1.CKS[2:0] bits are set to 000b, note that the characteristics of the digital noise filter may lead to the elimination of needed signals as noise.

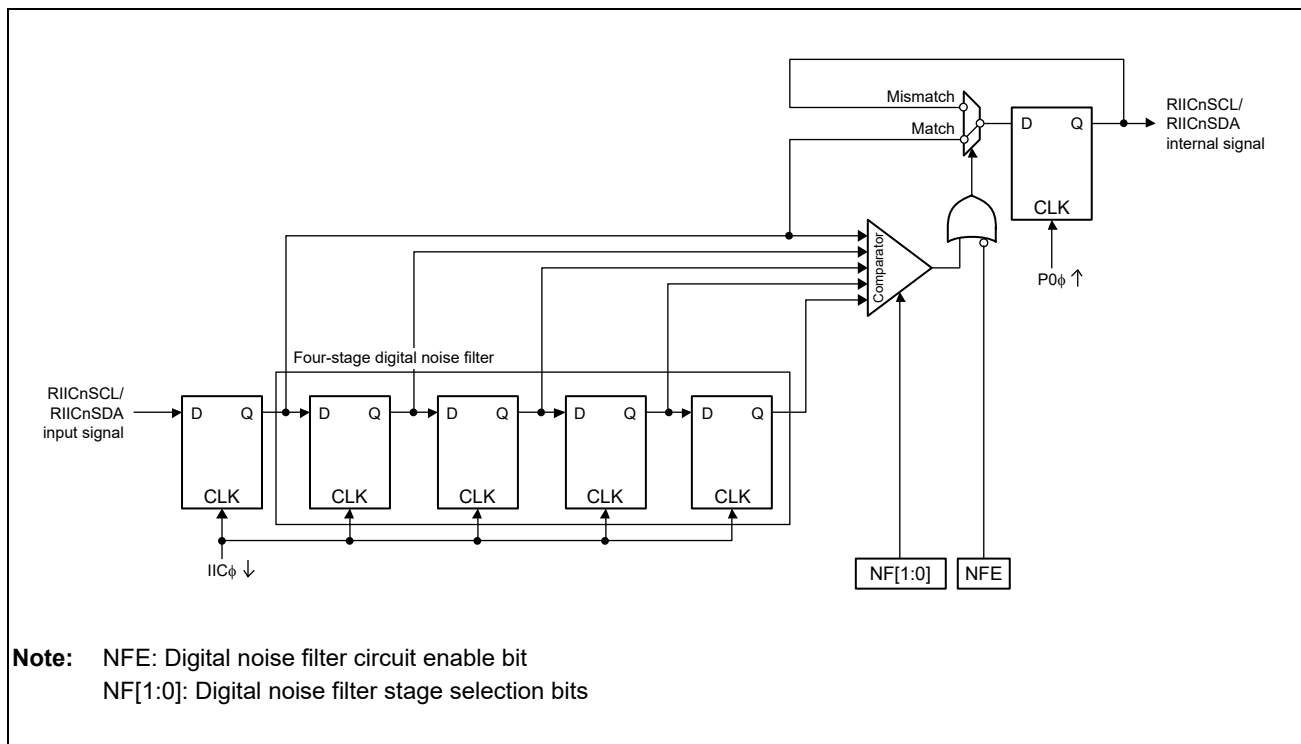

Figure 26.23 Block Diagram of Digital Noise Filter Circuit

26.9 Address Match Detection

The RIIC can set three unique slave addresses in addition to the general call address and host address, and also can set 7-bit or 10-bit slave addresses.

26.9.1 Slave-Address Match Detection

The RIIC can set three unique slave addresses, and has a slave address detection function for each unique slave address. When the RIICnSER.SARy bit (y = 0 to 2) is set to 1, the slave addresses set in RIICnSARy (y = 0 to 2) can be detected. When the RIIC detects a match of the set slave address, the corresponding RIICnSR1.AASy flag (y = 0 to 2) is set to 1 at the rising edge of the ninth SCL clock cycle, and the RIICnSR2.RDRF flag or the RIICnSR2.TDRE flag is set to 1 by the following R/W# bit. This causes a receive data full interrupt (INTRIICRI) or transmit data empty interrupt (INTRIICTI) to be generated. The AASy flag is used to identify which slave address has been specified.

Figure 26.24 to Figure 26.26 show the AASy flag set timing in three cases.

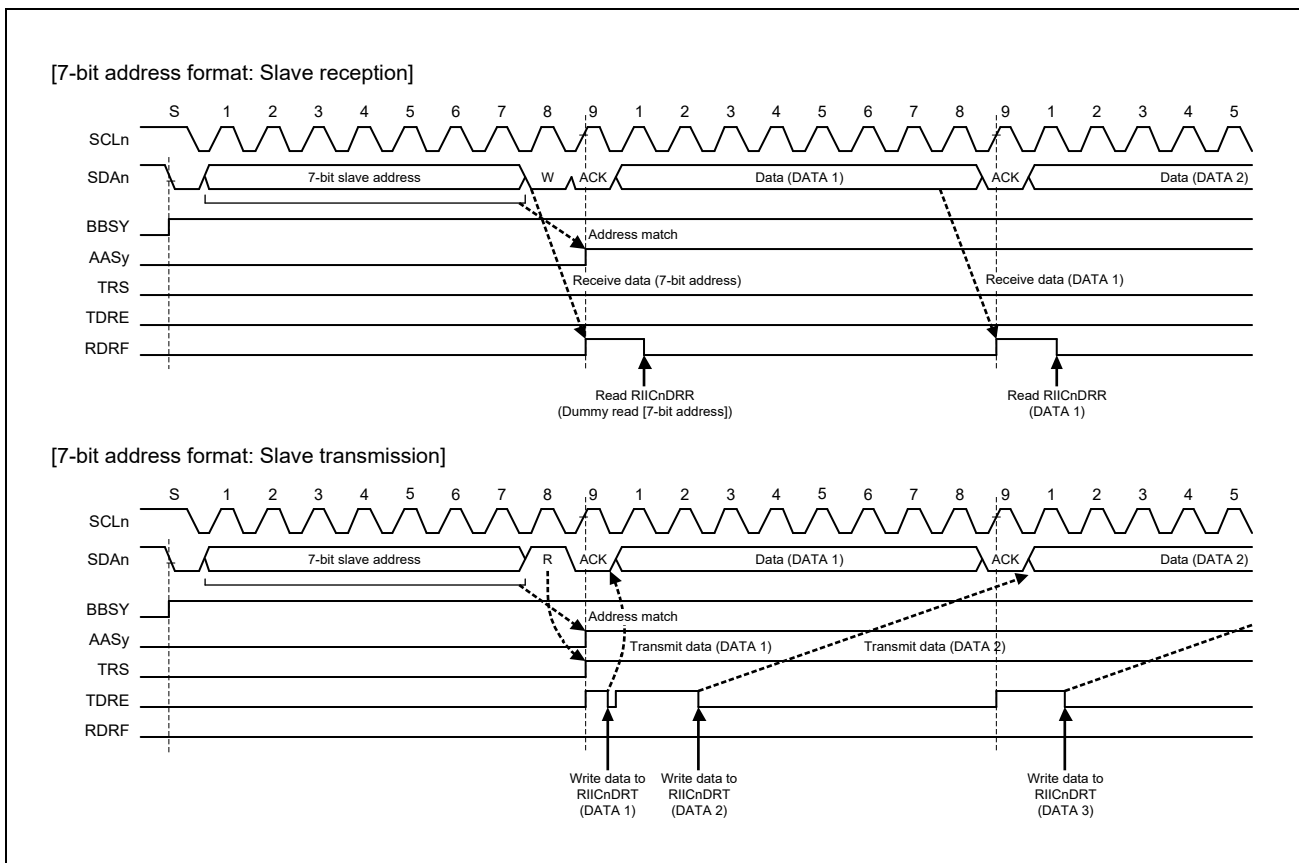

Figure 26.24 AASy Flag Set Timing with 7-Bit Address Format Selected

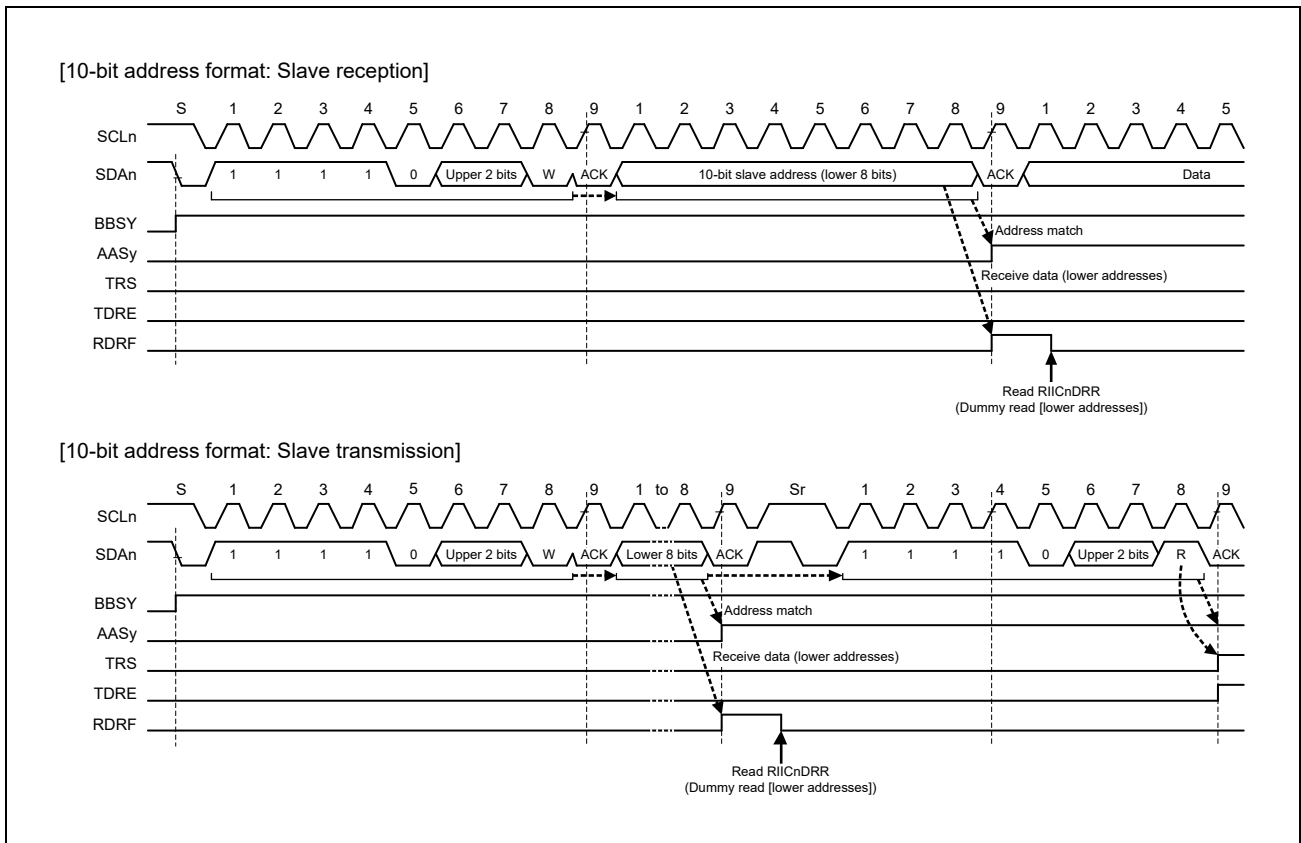

Figure 26.25 AASy Flag Set Timing with 10-Bit Address Format Selected

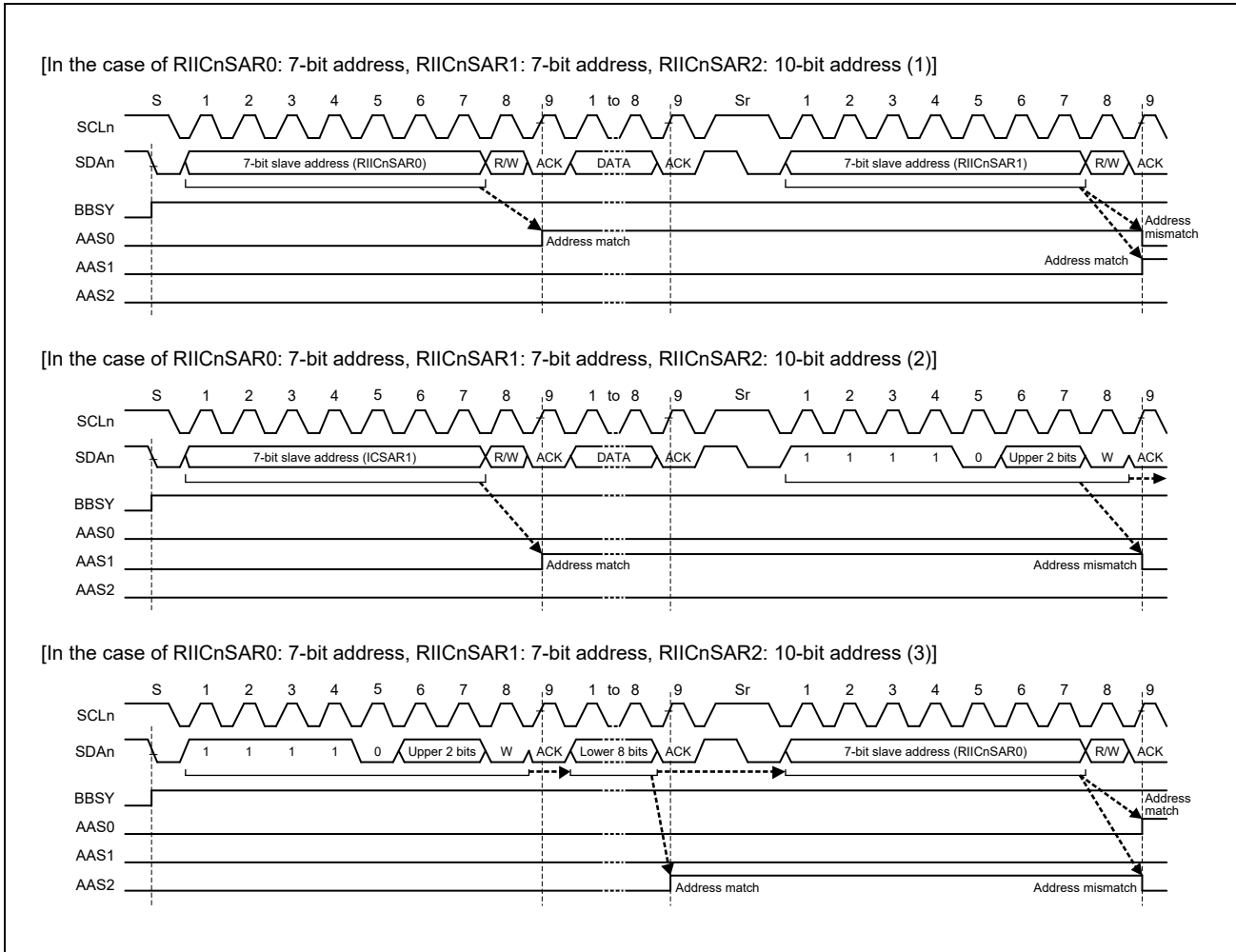

Figure 26.26 AASy Flag Set/Clear Timing with 7-Bit/10-Bit Address Formats Mixed

26.9.2 Detection of the General Call Address

The RIIC has a facility for detecting the general call address (0000 000b + 0 [W]). This is enabled by setting the RIICnSER.GCE bit to 1.

If the address received after a start or restart condition is issued is 0000 000b + 1[R] (start byte), the RIIC recognizes this as the address of a slave device with an “all-zero” address but not as the general call address.

When the RIIC detects the general call address, both the RIICnSR1.GCA flag and the RIICnSR2.RDRF flag are set to 1 on the rising edge of the ninth cycle of SCL clock. This leads to the generation of a receive data full interrupt (INTRIICRI). The value of the GCA flag can be confirmed to recognize that the general call address has been transmitted.

Operation after detection of the general call address is the same as normal slave receive operation.

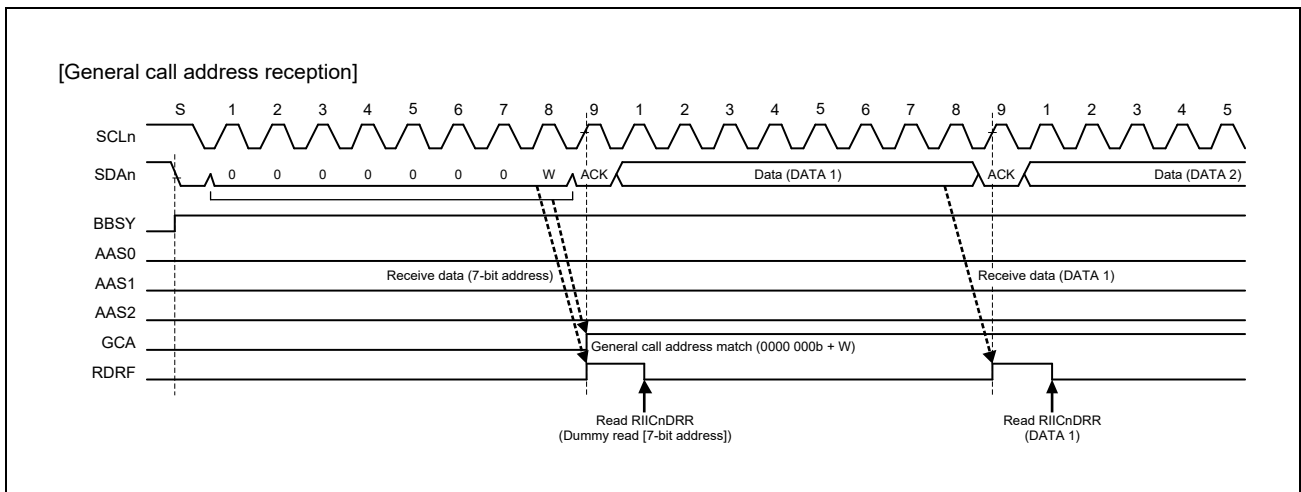

Figure 26.27 Timing of GCA Flag Setting during Reception of General Call Address

26.9.3 Device-ID Address Detection

The RIIC module has a facility for detecting device-ID addresses conformant with the I²C bus specification (Rev. 03). When the RIIC receives 1111 100b as the first byte after a start condition or restart condition was issued with the RIICnSER.DIDE bit set to 1, the RIIC recognizes the address as a device ID, sets the RIICnSR1.DID flag to 1 on the rising edge of the ninth SCL clock cycle when the following R/W# bit is 0, and then compares the second and subsequent bytes with its own slave address. If the address matches the value in the slave address register, the RIIC sets the corresponding RIICnSR1.AASy flag (y = 0 to 2) to 1.

After that, when the first byte received after a start or restart condition is issued matches the device ID address (1111 100b) again and the following R/W# bit is 1, the RIIC does not compare the second and subsequent bytes and sets the RIICnSR2.TDRE flag to 1.

In the device-ID address detection function, the RIIC clears the DID flag to 0 if a match with the RIIC's own slave address is not obtained or a match with the device ID address is not obtained after a match with the RIIC's own slave address and the detection of a restart condition. If the first byte after detection of a start or restart condition matches the device ID address (1111 100b) and the R/W# bit is 0, the RIIC sets the DID flag to 1 and compares the second and subsequent bytes with the RIIC's slave address. If the R/W# bit is 1, the DID flag holds the previous value and the RIIC does not compare the second and subsequent bytes. Therefore, the reception of a device-ID address can be checked by reading the DID flag after confirming that TDRE = 1.

Furthermore, prepare the device-ID fields (three bytes: 12 bits indicating the manufacturer + 9 bits identifying the part + 3 bits indicating the revision) that must be sent to the host after reception of a continuous device-ID field as normal data for transmission. For details, see I²C Bus Standard from NXP Semiconductors.

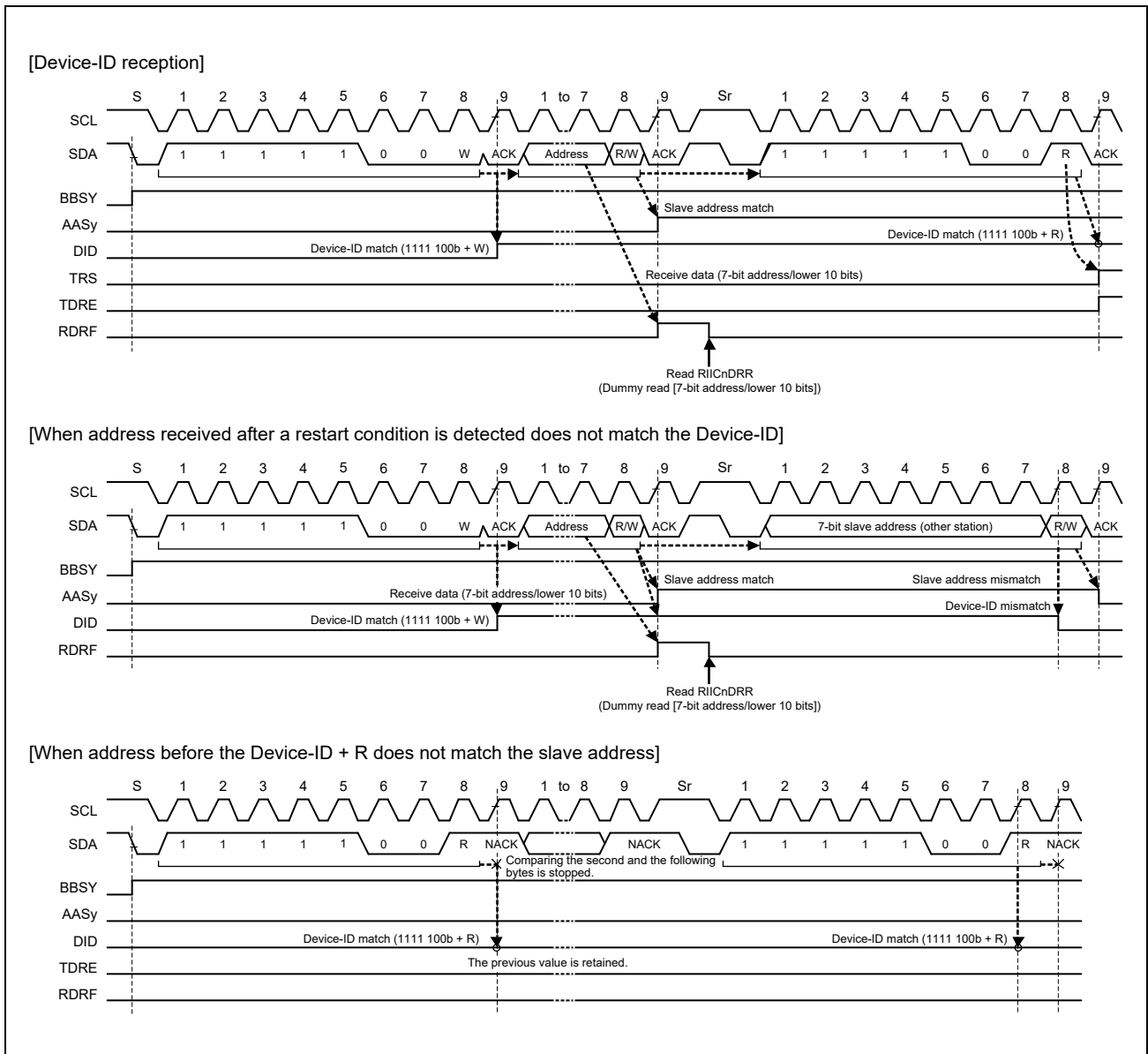

Figure 26.28 AASy/DID Flag Set/Clear Timing during Reception of Device-ID

26.9.4 Host Address Detection

The RIIC has a function to detect the host address while the SMBus is operating. When the RIICnSER.HOAE bit is set to 1 while the RIICnMR3.SMBS bit is 1, the RIIC can detect the host address (0001 000b) in slave receive mode (RIICnCR2.MST and TRS bits = 00b).

When the RIIC detects the host address, the RIICnSR1.HOA flag is set to 1 at the rising edge of the ninth SCL clock cycle, and at the same time, the RIICnSR2.RDRF flag is set to 1 when the R/W# bit is 0 (Wr bit). This causes a receive data full interrupt (INTRIICRI) to be generated. The HOA flag is used to recognize that the host address was sent from the smart battery or other devices.

If the bit following the host address (0001 000b) is an Rd bit (R/W# bit = 1), the RIIC can also detect the host address. After the host address is detected, the RIIC operates in the same manner as normal slave operation.

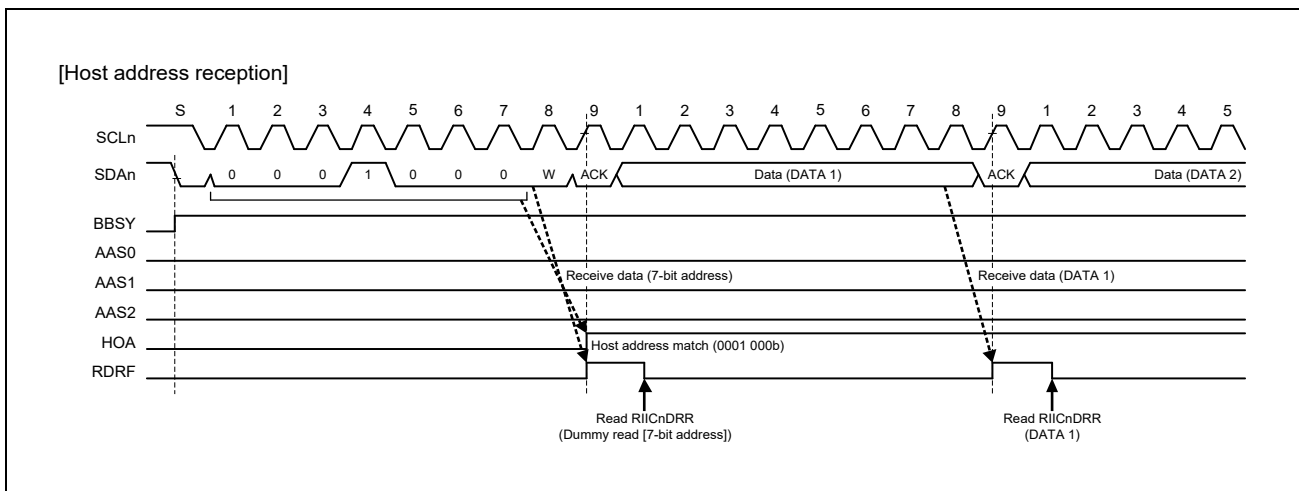

Figure 26.29 HOA Flag Set Timing during Reception of Host Address

26.10 Automatically Low-Hold Function for SCL

26.10.1 Function to Prevent Wrong Transmission of Transmit Data

If the shift register (RIICnDRS) is empty when data have not been written to the transmit data register (RIICnDRT) with the RIIC in transmission mode (RIICnCR2.TRS bit = 1), the SCL signal is automatically held at the low level over the intervals shown below. This low-hold period is extended until data for transmission have been written, which prevents the unintended transmission of erroneous data.

<Master transmit mode>

- Low-level interval after a start condition or restart condition is issued
- Low-level interval of one clock cycle between the ninth clock cycle of one transfer and the first clock cycle of the next

<Slave transmit mode>

- Low-level interval between the ninth clock cycle of one transfer and the first clock cycle of the next

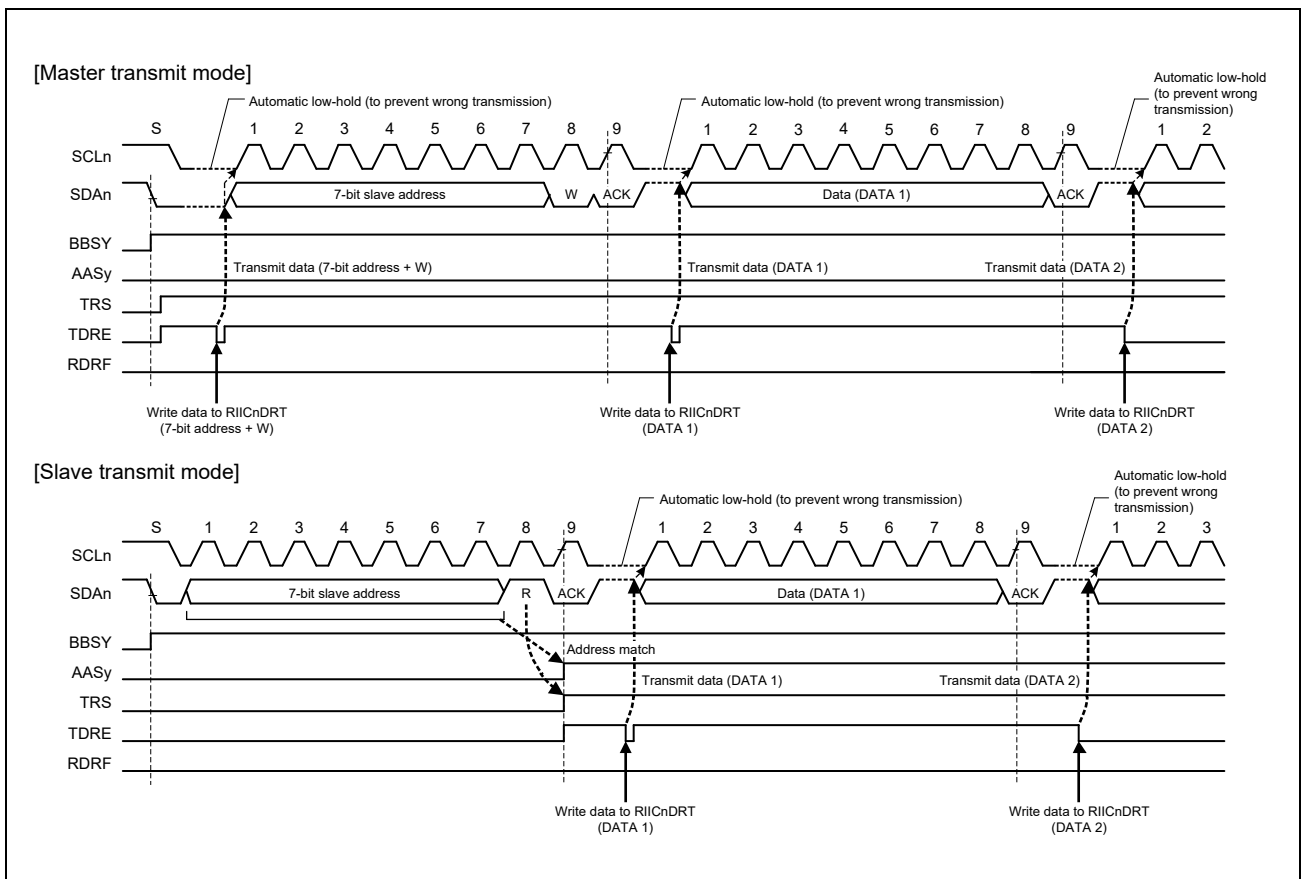

Figure 26.30 Automatic Low-Hold Operation in Transmit Mode

26.10.2 NACK Reception Transfer Suspension Function

The RIIC has a function to suspend transfer operation when NACK is received in transmit mode (RIICnCR2.TRS bit = 1). This function is enabled when the RIICnFER.NACKE bit is set to 1 (transfer suspension enabled). If the next transmit data has already been written (RIICnSR2.TDRE flag = 0) when NACK is received, next data transmission at the falling edge of the ninth SCL clock cycle is automatically suspended. This prevents the SDA line output level from being held low when the MSB of the next transmit data is 0.

If the transfer operation is suspended by this function (RIICnSR2.NACKF flag = 1), transmit operation and receive operation are discontinued. To restore transmit/receive operation, be sure to clear the NACKF flag to 0. In master transmit mode, clear the NACKF flag to 0 after issuing a restart condition or clear the NACKF and STOP flags to 0 after confirming that a stop condition has been issued, and then issue a start condition.

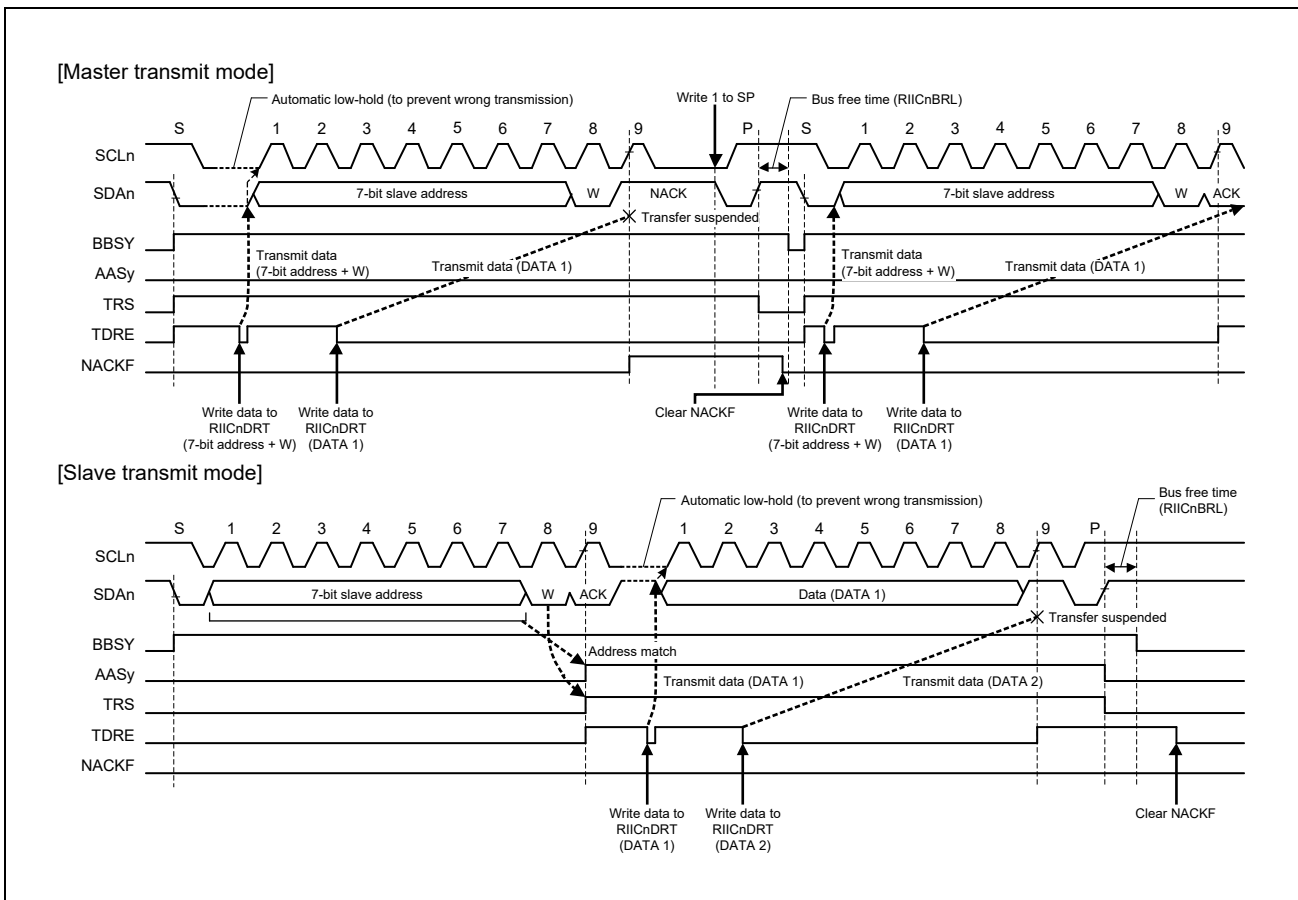

Figure 26.31 Suspension of Data Transfer when NACK is Received (NACKE = 1)

26.10.3 Function to Prevent Failure to Receive Data

If response processing is delayed when receive data (RIICnDRR) read is delayed for a period of one transfer frame or more with receive data full (RIICnSR2.RDRF flag = 1) in receive mode (RIICnCR2.TRS = 0), the RIIC holds the SCL line low automatically immediately before the next data is received to prevent failure to receive data.

This function to prevent failure to receive data using the automatic low-hold function is also enabled even if the read processing of the final receive data is delayed and, in the meantime, the RIIC's own slave address is designated after a stop condition is issued. This function does not disturb other communication because the RIIC does not hold the SCL line low when a mismatch with its own slave address occurs after a stop condition is issued.

Sections in which the SCL line is held low can be selected with a combination of the RIICnMR3.WAIT and RDRFS bits.

(1) One-Byte Receive Operation and Automatic Low-Hold Function Using the WAIT Bit

When the RIICnMR3.WAIT bit is set to 1, the RIIC performs one-byte receive operation using the WAIT bit function. Furthermore, when the RIICnMR3.RDRFS bit is 0, the RIIC automatically sends the RIICnMR3.ACKBT bit value for the acknowledge bit in the period from the falling edge of the eighth SCL clock cycle to the falling edge of the ninth SCL clock cycle, and automatically holds the SCL line low at the falling edge of the ninth SCL clock cycle using the WAIT bit function. This low-hold is released by reading data from RIICnDRR, which enables bitwise receive operation.

The WAIT bit function is enabled for receive frames after a match with the RIIC's own slave address (including the general call address and host address) is obtained in master receive mode or slave receive mode.

(2) One-Byte Receive Operation (ACK/NACK Transmission Control) and Automatic Low-Hold Function Using the RDRFS Bit

When the RIICnMR3.RDRFS bit is set to 1, the RIIC performs one-byte receive operation using the RDRFS bit function. When the RIICnSR2.RDRFS bit is set to 1, the RDRF flag (receive data full) in RIICnSR2 is set to 1 at the rising edge of the eighth SCL clock cycle, and the SCL line is automatically held low at the falling edge of the eighth SCL clock cycle. This lowhold is released by writing a value to the RIICnMR3.ACKBT bit, but cannot be released by reading data from RIICnDRR, which enables receive operation by the ACK/NACK transmission control according to the data received in byte units.

The RDRFS bit function is enabled for receive frames after a match with the RIIC's own slave address (including the general call address and host address) is obtained in master receive mode or slave receive mode.

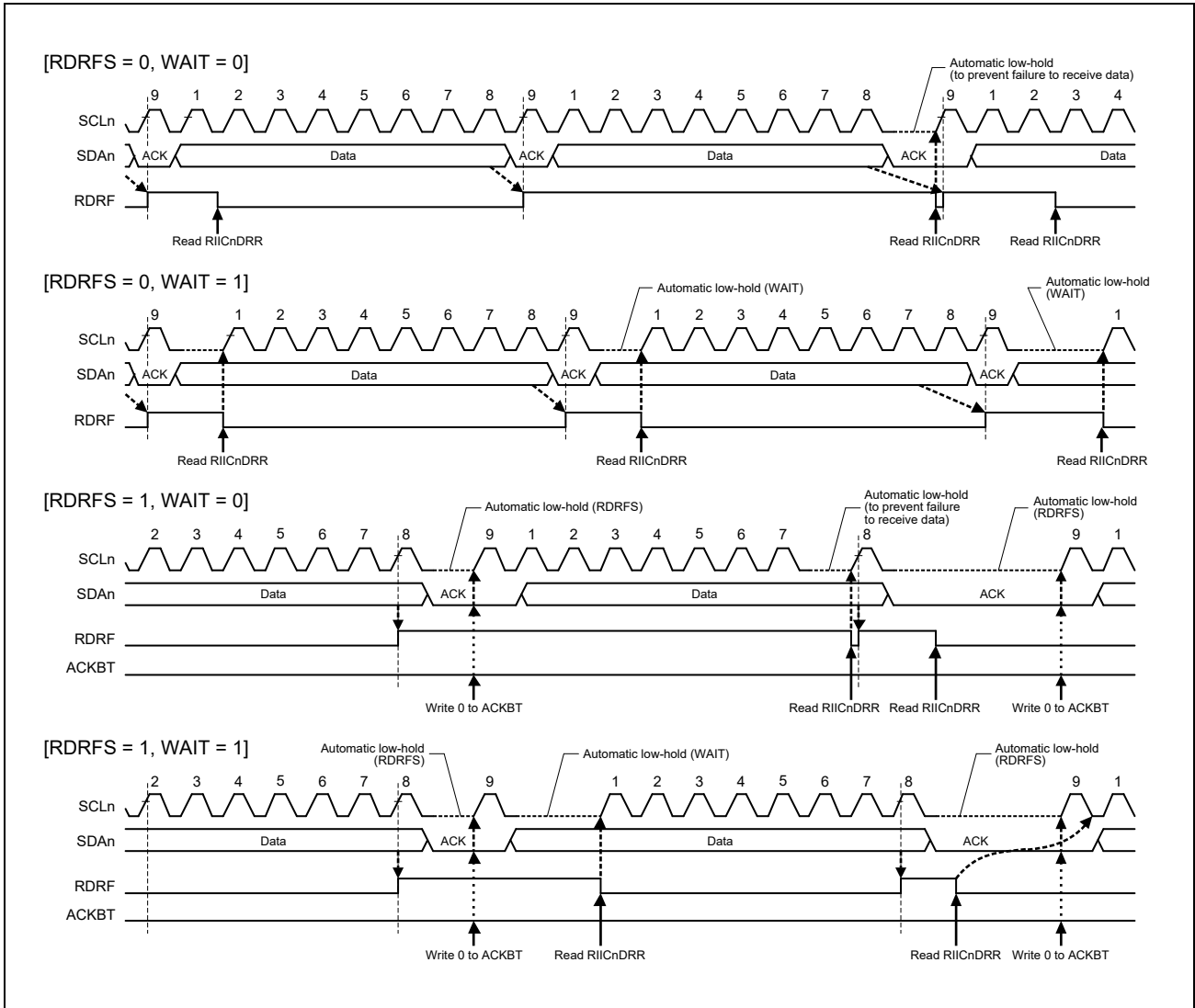

Figure 26.32 Automatic Low-Hold Operation in Receive Mode (Using RDRFS and WAIT Bits)

26.11 Arbitration-Lost Detection Functions

In addition to the normal arbitration-lost detection function defined by the I²C bus standard, the RIIC has functions to prevent double-issue of a start condition, to detect arbitration-lost during transmission of NACK, and to detect arbitration-lost in slave transmit mode.

26.11.1 Master Arbitration-Lost Detection (MALE Bit)

The RIIC drives the SDA line low to issue a start condition. However, if the SDA line has already been driven low by another master device issuing a start condition, the RIIC regards its own issuing of a start condition as an error and considers this a loss in arbitration, so priority is given to transfer by the other master device. Similarly, if a request to issue a start condition is made by setting the RIICnCR2.ST bit to 1 while the bus is busy (RIICnCR2.BBSY flag = 1), the RIIC regards this as a double-issuing-of-start-condition error and considers itself to have lost in arbitration, thus preventing a failure of transfer due to issuing of a start condition while transfer is in progress.

When a start condition is issued successfully, if the data for transmission including the address bits (i.e. the internal SDA output level) and the level on the SDA line do not match (the high output as the internal SDA output; i.e. the SDA pin is in the high-impedance state) and the low level is detected on the SDA line, the RIIC loses in arbitration.

After a loss in arbitration of mastership, the RIIC immediately enters slave receive mode. If a slave address (including the general call address) matches its own address at this time, the RIIC continues in slave operation.

A loss in arbitration of mastership is detected when the following conditions are met while the RIICnFER.MALE bit is 1 (master arbitration-lost detection enabled).

[Master arbitration-lost conditions]

- Non-matching of the internal level for output on SDA and the level on the SDA line after a start condition was issued by setting the RIICnCR2.ST bit to 1 while the RIICnCR2.BBSY flag was cleared to 0 (erroneous issuing of a start condition)
- Setting of the RIICnCR2.ST bit to 1 (start condition double-issue error) while the RIICnCR2.BBSY flag is set to 1
- When the transmit data excluding acknowledge (internal SDA output level) does not match the level on the SDA line in master transmit mode (RIICnCR2.MST and TRS bits = 11b)

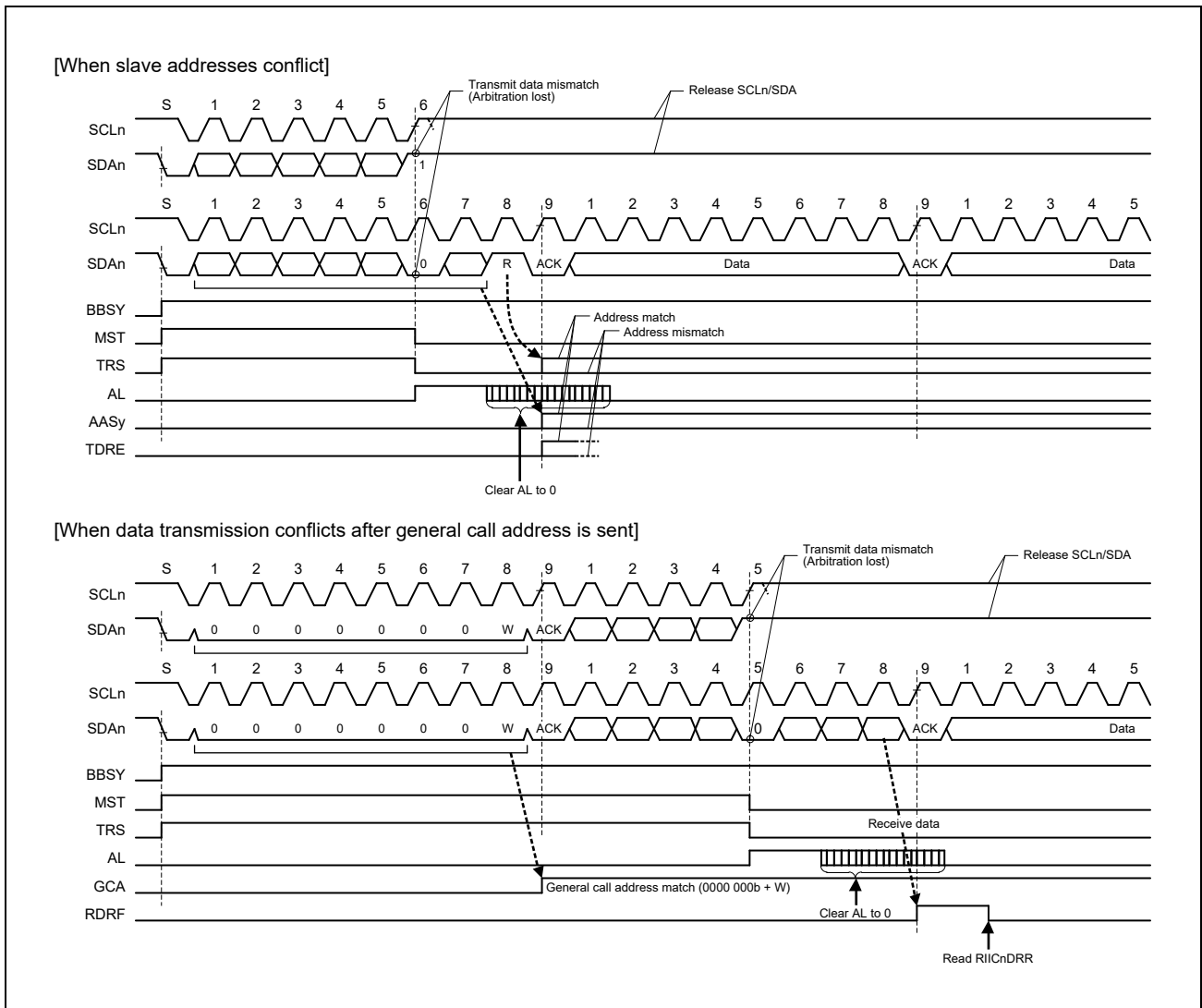

Figure 26.33 Examples of Master Arbitration-Lost Detection (MALE = 1)

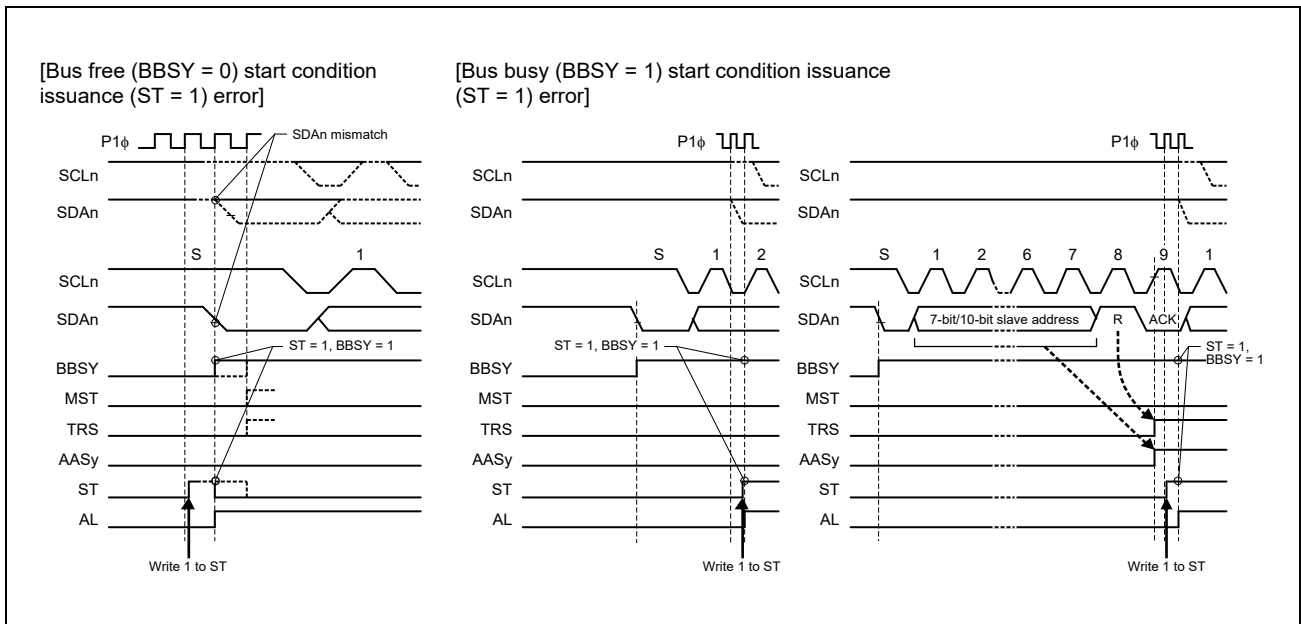

Figure 26.34 Arbitration-Lost when a Start Condition is Issued (MALE = 1)

26.11.2 Function to Detect Loss of Arbitration during NACK Transmission (NALE Bit)

The RIIC has a function to cause arbitration to be lost if the internal SDA output level does not match the level on the SDA line (the high output as the internal SDA output; i.e. the SDA pin is in the high-impedance state) and the low level is detected on the SDA line during transmission of NACK in receive mode. Arbitration is lost due to a conflict of NACK transmission and ACK transmission when two or more master devices receive data from the same slave device simultaneously in a multi-master system. Such conflict occurs when multiple master devices send/receive the same information through a single slave device. **Figure 26.35** shows an example of arbitration-lost detection during transmission of NACK.

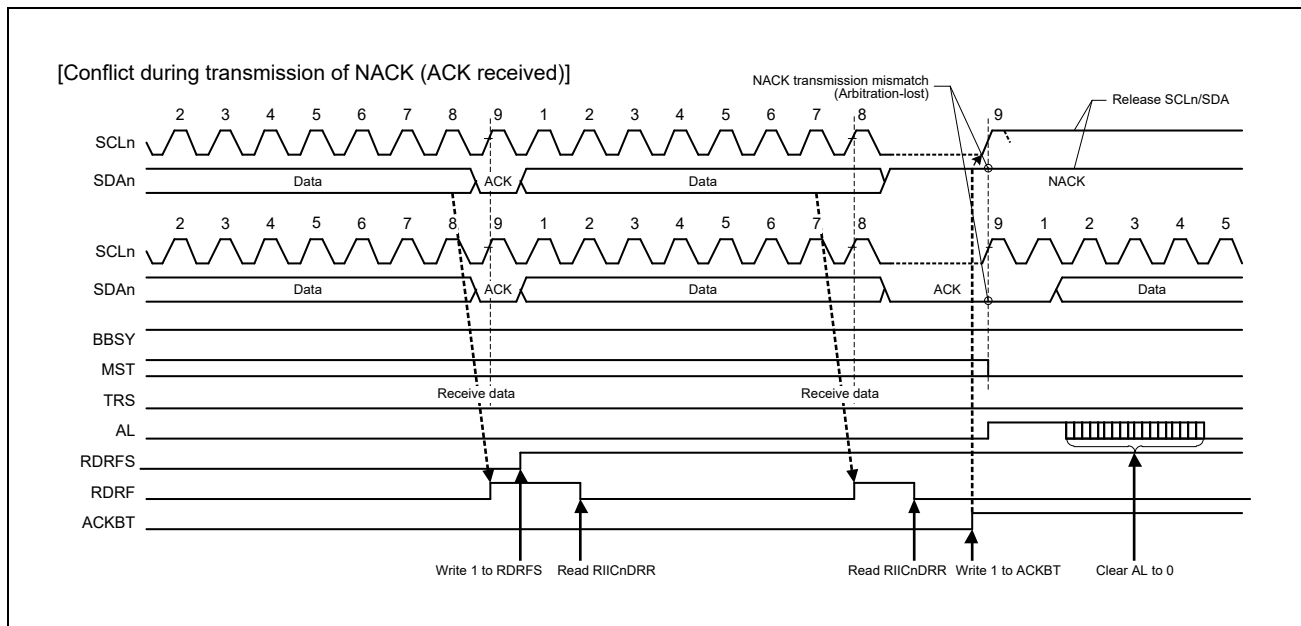

Figure 26.35 Example of Arbitration-Lost Detection during Transmission of NACK (NALE = 1)

The following explains arbitration-lost detection using an example where two master devices (master A and master B) and a single slave device are connected through the bus. In this example, master A receives two bytes of data from the slave device, and master B receives four bytes of data from the slave device.

If master A and master B access the slave device simultaneously, because the slave address is identical, arbitration is not lost in both master A and master B during access to the slave device. Therefore, both master A and master B recognize that they have obtained the bus mastership and operate as such. Here, master A sends NACK when it has received two final bytes of data from the slave device. Meanwhile, master B sends ACK because it has not received necessary four bytes of data. At this time, the NACK transmission from master A and the ACK transmission from master B conflict. In general, if a conflict like this occurs, master A cannot detect ACK transmitted by master B and issues a stop condition. Therefore, the issuance of the stop condition conflicts with the SCL clock output of master B, which disturbs communication.

When the RIIC receives ACK during transmission of NACK, it detects a defeat in conflict with other master devices and causes arbitration to be lost.

If arbitration is lost during transmission of NACK, the RIIC enters slave receive mode. This prevents a stop condition from being issued, preventing a communication failure on the bus.

Similarly, in the ARP command processing of SMBus, the function to detect loss of arbitration during transmission of NACK is also available for eliminating the extra clock cycle processing (such as H'FF transmission processing)

necessary if the UDID (Unique Device Identifier) of assign address does not match in the Get UDID (general) processing after the Assign address command.

The RIIC detects arbitration-lost during transmission of NACK when the following condition is met with the RIICnFER.NALE bit set to 1 (arbitration-lost detection during NACK transmission enabled).

[Condition for arbitration-lost during NACK transmission]

When the internal SDA output level does not match the SDA line (ACK is received) during transmission of NACK (RIICnMR3.ACKBT bit = 1).

26.11.3 Slave Arbitration-Lost Detection (SALE Bit)

The RIIC has a function to cause arbitration to be lost if the data for transmission (i.e. the internal SDA output level) and the level on the SDA line do not match (the high output as the internal SDA output; i.e. the SDA pin is in the highimpedance state) and the low level is detected on the SDA line in slave transmit mode. This arbitration-lost detection function is mainly used when transmitting a UDID (Unique Device Identifier) over an SMBus.

When it loses slave arbitration, the RIIC enters slave receive mode. This function can detect conflicts of data during transmission of UDIDs over an SMBus and eliminates subsequent redundant processing (processing for the transmission of H'FF).

The RIIC detects slave arbitration-lost when the following condition is met with the RIICnFER.SALE bit set to 1 (slave arbitration-lost detection enabled). [Condition for slave arbitration-lost]

When transmit data excluding acknowledge (internal SDA output level) does not match the SDA line in slave transmit mode (RIICnCR2.MST and TRS bits = 01b)

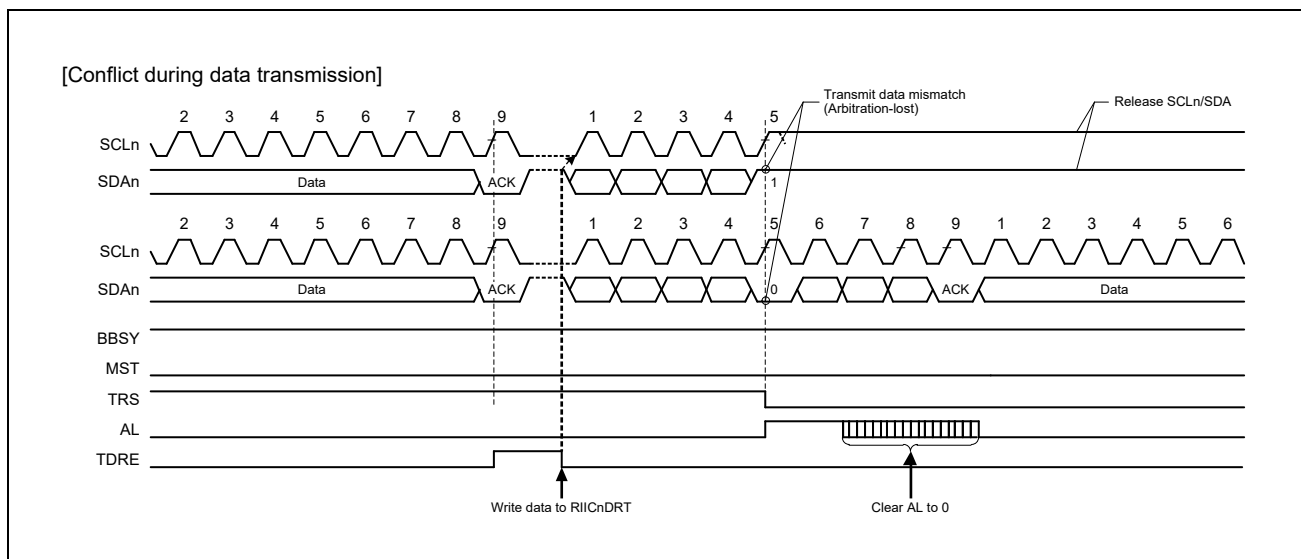

Figure 26.36 Example of Slave Arbitration-Lost Detection (SALE = 1)

26.12 Start Condition/Restart Condition/Stop Condition Issuing Function

26.12.1 Issuing a Start Condition

The RIIC issues a start condition when the RIICnCR2.ST bit is set to 1.

When the ST bit is set to 1, a start condition issuance request is made and the RIIC issues a start condition when the RIICnCR2.BBSY flag is 0 (bus free). When a start condition is issued normally, the RIIC automatically shifts to the master transmit mode.

A start condition is issued in the following sequence.

[Start condition issuance]

- Drive the SDA line low (high level to low level).
- Ensure the time set in RIICnBRH and the start condition hold time.
- Drive the SCL line low (high level to low level).
- Detect low level of the SCL line and ensure the low-level period of SCL line set in RIICnBRL.

26.12.2 Issuing a Restart Condition

The RIIC issues a restart condition when the RIICnCR2.RS bit is set to 1.

When the RS bit is set to 1, a restart condition issuance request is made and the RIIC issues a restart condition when the RIICnCR2.BBSY flag is 1 (bus busy) and the RIICnCR2.MST bit is 1 (master mode).

A restart condition is issued in the following sequence.

[Restart condition issuance]

- Release the SDA line.
- Ensure the low-level period of SCL line set in RIICnBRL.
- Release the SCL line (low level to high level).
- Detect a high level of the SCL line and ensure the time set in RIICnBRL and the restart condition setup time.
- Drive the SDA line low (high level to low level).
- Ensure the time set in RIICnBRH and the restart condition hold time.
- Drive the SCL line low (high level to low level).
- Detect a low level of the SCL line and ensure the low-level period of SCL line set in RIICnBRL.

CAUTION

To issue a restart condition request, set RIICnSR2.RS to 1 after setting RIICnSR2.START to 0. After checking that RIICnSR2.START is 1, set RIICnSR2.START to 0, and then write the slave address to RIICnDRT.

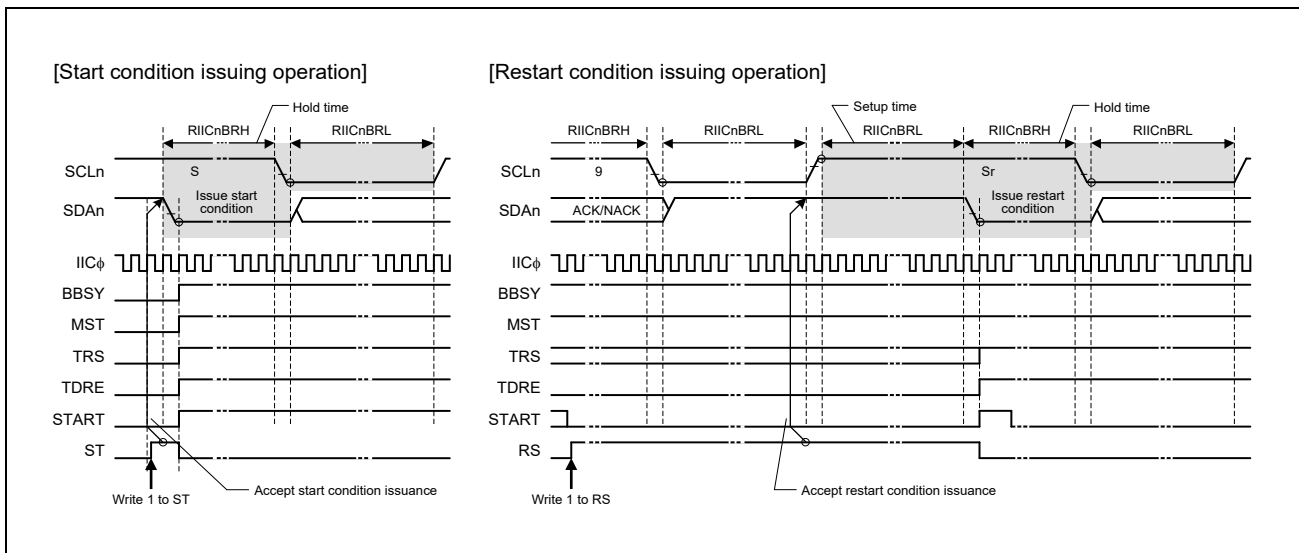

Figure 26.37 Start Condition/Restart Condition Issue Timing (ST and RS Bits)

26.12.3 Issuing a Stop Condition

The RIIC issues a stop condition when the RIICnCR2.SP bit is set to 1.

When the SP bit is set to 1, a stop condition issuance request is made and the RIIC issues a stop condition when the RIICnCR2.BBSY flag is 1 (bus busy) and the RIICnCR2.MST bit is 1 (master mode).

A stop condition is issued in the following sequence.

[Stop condition issuance]

- Drive the SDA line low (high level to low level).
- Ensure the low-level period of SCL line set in RIICnBRL.
- Release the SCL line (low level to high level).
- Detect a high level of the SCL line and ensure the time set in RIICnBRH and the stop condition setup time.
- Release the SDA line (low level to high level).
- Ensure the time set in RIICnBRL and the bus free time.
- Clear the BBSY flag to 0 (to release the bus mastership).

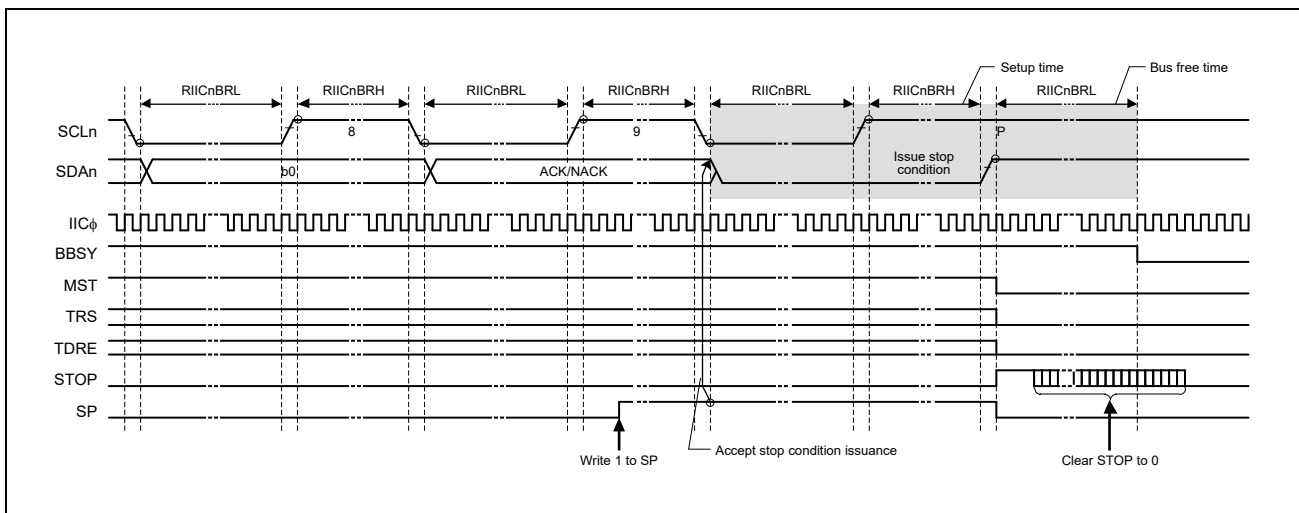

Figure 26.38 Stop Condition Issue Timing (SP Bit)

26.13 Bus Hanging

If the clock signals from the master and slave devices go out of synchronization due to noise or other factors, the I²C bus might hang with a fixed level on the SCL line and/or SDA line.

As measures against the bus hanging, the RIIC has a timeout function to detect hanging by monitoring the SCL line, a function for the output of an extra SCL clock cycle to release the bus from a hung state due to clock signals being out of synchronization, and the RIIC/internal reset function.

By checking the RIICnCR1.SCLO, SDAO, SCLI, and SDAI bits, it is possible to see whether the RIIC or its partner in communications is placing the low level on the SCL or SDA lines.

26.13.1 Timeout Function

The RIIC has the timeout function to detect an abnormality that the SCL line is held for a certain period of time. The RIIC can detect an abnormal bus state by monitoring that the SCL line is held low or high for a predetermined time. The timeout function monitors the SCL line state and counts the low-level period or high-level period using the internal counter. The timeout function resets the internal counter each time the SCL line changes (rising or falling), but continues to count unless the SCL line changes. If the internal counter overflows due to no SCL line change, the RIIC can detect the timeout and report the bus abnormality.

This timeout function is enabled when the RIICnFER.TMOE bit is 1. It detects an abnormal bus state in which the SCL line is held low or high in the following cases.

1. When the bus is busy (RIICnCR2.BBSY = 1) in master mode (RIICnCR2.MST = 1)
2. When the bus is busy (RIICnCR2.BBSY = 1) and the RIIC's own slave address matches (RIICnSR1 is not H'00) in slave mode (RIICnCR2.MST = 0)
3. While the bus is free (RIICnCR2.BBSY = 0) and issuing of a start condition is being requested (RIICnCR2.ST = 1).

The internal counter of the timeout function works using the internal reference clock (IIC ϕ) set by the RIICnMR1.CKS[2:0] bits as a count source. It functions as a 16-bit counter when long mode is selected (RIICnMR2.TMOS bit = 0) or a 14-bit counter when short mode is selected (TMOS bit = 1).

The SCL line level (low/high or both levels) during which this counter is activated can be selected by the setting of the RIICnMR2.TMOH and TMOL bits. If both TMOL and TMOH bits are cleared to 0, the internal counter does not work.

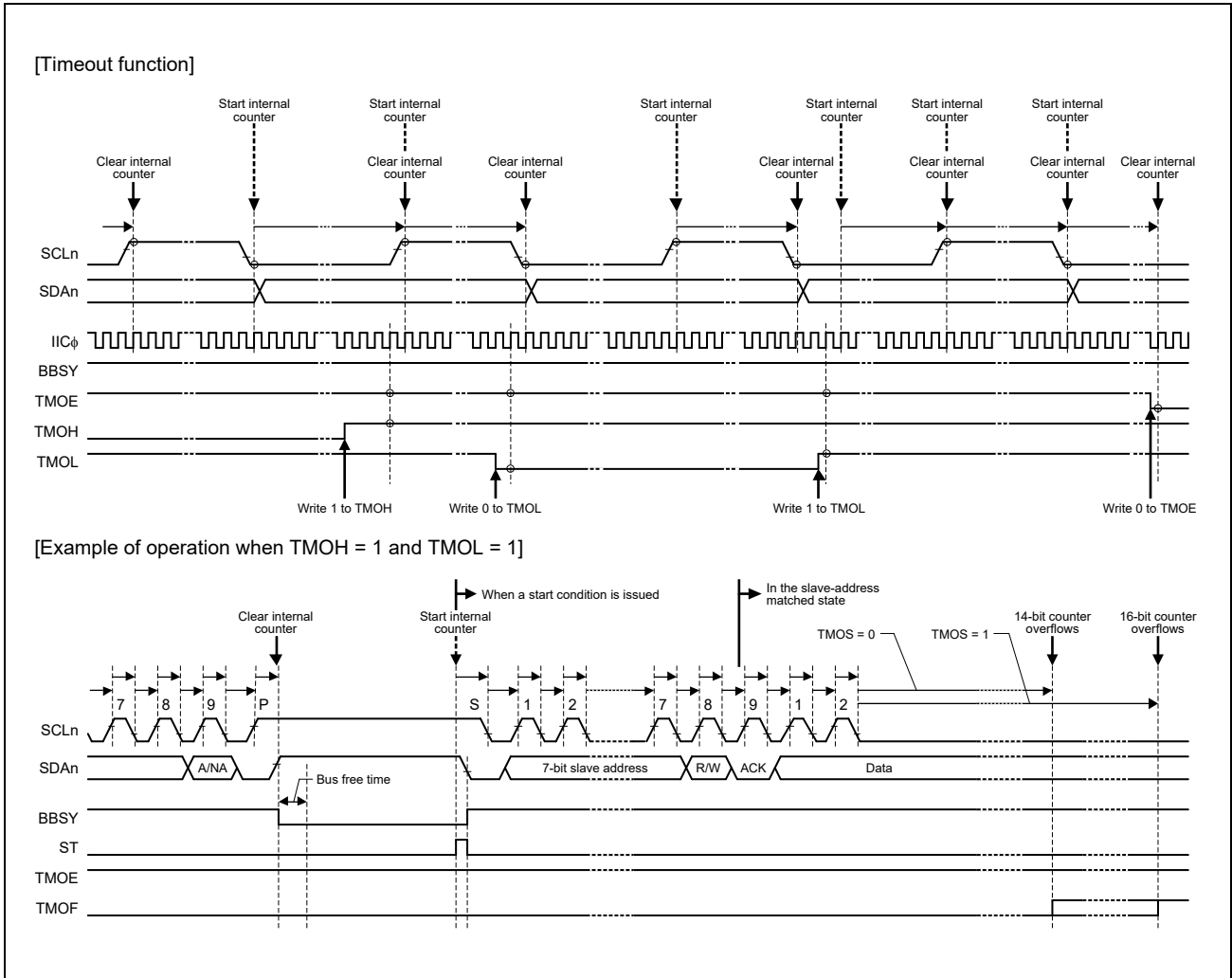

Figure 26.39 Timeout Function (TMOE, TMOS, TMOH, and TMOL Bits)

26.13.2 Extra SCL Clock Cycle Output Function

In master mode, the RIIC module has a facility for the output of extra SCL (clock) cycles to release the SDA line of the slave device from being held at the low level due to the master being out of synchronization with the slave device.

This function is mainly used in master mode to release the SDA line of the slave device from the state of being fixed to the low level by including extra cycles of SCL output from the RIIC with single cycles of the SCL (clock) signal as the unit in the case of a bus error where the RIIC cannot issue a stop condition because the slave device is holding the SDA line at the low level. Do not use this facility in normal situations. Using it when communications are proceeding correctly will lead to malfunctions.

When the RIICnCR1.CLO bit is set to 1 in master mode, a single cycle of the SCL clock at the frequency corresponding to the transfer rate settings (settings of the RIICnMR1.CKS[2:0] bits, and of the RIICnBRH and RIICnBRL registers) is output as an extra clock cycle. After output of this single cycle of the SCL clock, the CLO bit is automatically cleared to 0. At this point, the SCL pin output is held at a low level if the BBSY flag is 1, or the SCL pin outputs at high level if the BBSY flag is 0. Further clock cycles can consecutively be output by writing 1 to the CLO bit after having read CLO is 0 by software.

When the RIIC module is in master mode and the slave device is holding the SDA line at the low level because synchronization with the slave device has been lost due to the effects of noise, etc., the output of a stop condition is not possible. The facility for output of an extra cycle of the SCL (clock) signal can be used to output extra cycles of SCL one by one to make the slave device release the SDA line from being held at the low level, thus recovering the bus from an unusable state. Release of the SDA line by the slave device can be monitored by reading the RIICnCR1.SDAI bit. After confirming release of the SDA line by the slave device, complete communications by reissuing the stop condition.

[Output conditions for using the RIICnCR1.CLO bit]

- When the bus is free (RIICnCR2.BBSY flag = 0) or in master mode (RIICnCR2.MST bit = 1 and BBSY flag = 1)
- When the communication device does not hold the SCL line low

Figure 26.40 shows the operation timing of the extra SCL clock cycle output function (CLO bit).

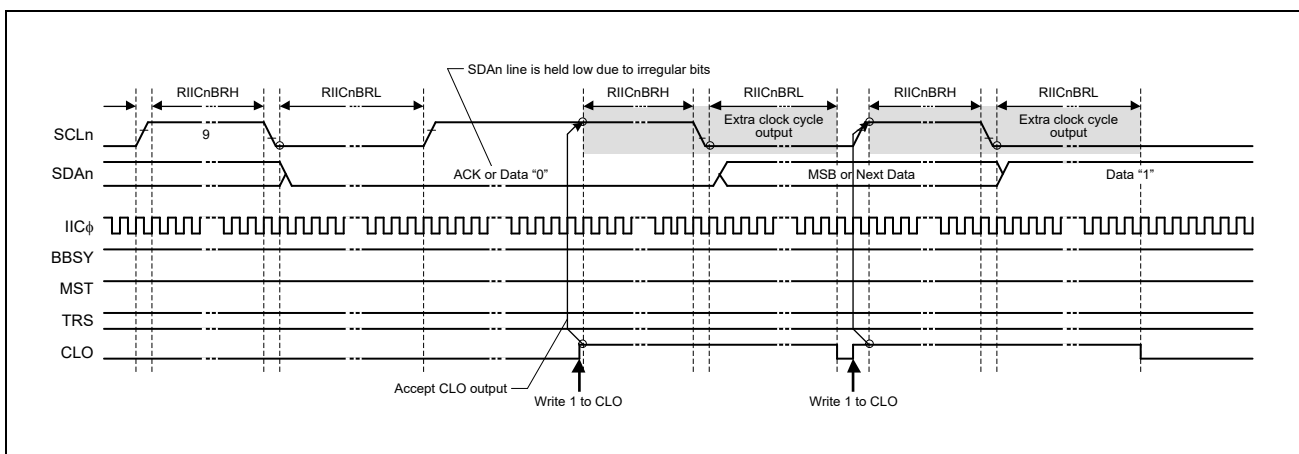

Figure 26.40 Extra SCL Clock Cycle Output Function (CLO Bit)

26.13.3 RIIC Reset and Internal Reset

The RIIC module incorporates a function for resetting itself. There are two types of reset. One is referred to as an RIIC reset; this initializes all registers including the RIICnCR2.BBSY flag. The other is referred to as an internal reset; this releases the RIIC from the slave-address matched state and initializes the internal counter while retaining other settings. After issuing a reset, be sure to clear the RIICnCR1.IICRST bit to 0.

Both types of reset are effective for release from bus-hung states since both restore the output state of the SCL and SDA pins to the high impedance state.

Issuing a reset during slave operation may lead to a loss of synchronization between the master device clock and the slave device clock, so avoided this where possible. Note that monitoring of the bus state, such as for the presence of a start condition, is not possible during an RIIC reset (RIICnCR1.IICE and IICRST bits = 01b).

For a detailed description of the RIIC and internal resets, see **Section 26.15, Reset Function of RIIC**.

26.14 SMBus Operation

The RIIC is available for data communication conforming to the SMBus (Version 2.0). To perform SMBus communication, set the RIICnMR3.SMBS bit to 1. To use the transfer rate within a range of 10 kbps to 100 kbps of the SMBus standard, set the RIICnMR1.CKS[2:0] bits, RIICnCBRH, and RIICnBRL. In addition, determine the values of the RIICnMR2.DLCS bit and the RIICnMR2.SDDL[2:0] bits to meet the data hold time specification of 300 ns or more. If the RIIC is used only as a slave device, the transfer rate setting is not necessary. When the RIIC is used only as a slave device, the transfer rate setting is not necessary, whereas the RIICnBRL needs to be set to a value at least the same as the data setup time (250 ns).

For the SMBus device default address (1100 001b), use one of the slave address registers L0 to L2 (RIICnSAR0, RIICnSAR1, and RIICnSAR2), and set the corresponding RIICnSARy.FSy bit (7-bit/10-bit address format select) (y = 0 to 2) to 0 (7-bit address format).

When transmitting the UDID (Unique Device Identifier), set the RIICnFER.SALE bit to 1 to enable the slave arbitration lost detection function.

26.14.1 SMBus Timeout Measurement

(1) Measuring timeout of slave device

The following period (timeout interval: $T_{\text{LOW:SEXT}}$) must be measured for slave devices in SMBus communication.

- From start condition to stop condition

To measure timeout for slave devices, measure the period from start condition detection to stop condition detection with the internal timer using a start condition detection interrupt (INTRIICSTI) and stop condition detection interrupt (INTRIICSPI) of the RIIC. The measured timeout period must be within the total clock low-level period [slave device] $T_{\text{LOW:SEXT}}$: 25 ms (max.) of the SMBus standard.

If the time measured with the internal timer exceeds the clock low-level detection timeout T_{TIMEOUT} : 25 ms (min.) of the SMBus standard, the slave device must release the bus by writing 1 to the RIICnCR1.IICRST bit to issue an internal reset of the RIIC. When an internal reset is issued, the RIIC stops driving the bus for the SCL pin and SDA pin and make the SCL/SDA pin outputs high impedance, which releases the bus.

(2) Measuring timeout of master device

The following periods (timeout interval: $T_{\text{LOW:MEXT}}$) must be measured for master devices in SMBus communication.

- From start condition to acknowledge bit
- Between acknowledge bits
- From acknowledge bit to stop condition

To measure timeout for master devices, measure these periods with the internal timer using a start condition detection interrupt (INTRIICSTI), stop condition detection interrupt (INTRIICSPI), and transmit end interrupt (INTRIICTEI) or receive data full interrupt (INTRIICRI) of the RIIC. The measured timeout period must be within the total clock low-level extended period [master device] $T_{\text{LOW:MEXT}}$: 10 ms (max.) of the SMBus standard, and the total of all $T_{\text{LOW:MEXT}}$ from start condition to stop condition must be within $T_{\text{LOW:SEXT}}$: 25 ms (max.).

For the ACK receive timing (rising edge of the ninth SMBCLK clock cycle), monitor the RIICnSR2.TEND flag in master transmit mode (master transmitter) and the RIICnSR2.RDRF flag in master receive mode (master receiver). For this reason, perform bitwise transmit operation in master transmit mode, and hold the RIICnMR3.RDRFS bit 0 until the byte just before reception of the final byte in master receive mode. While the RDRFS bit is 0, the RDRF flag is set to 1 at the rising edge of the ninth SMBCLK clock cycle.

If the period measured with the internal timer exceeds the total clock low-level extended period [master device] $T_{LOW:MEXT}$: 10 ms (max.) of the SMBus standard or the total of measured periods exceeds the clock low-level detection timeout $T_{TIMEOUT}$: 25 ms (min.) of the SMBus standard, the master device must stop the transaction by issuing a stop condition. In master transmit mode, immediately stop the transmit operation (writing data to RIICnDRT).

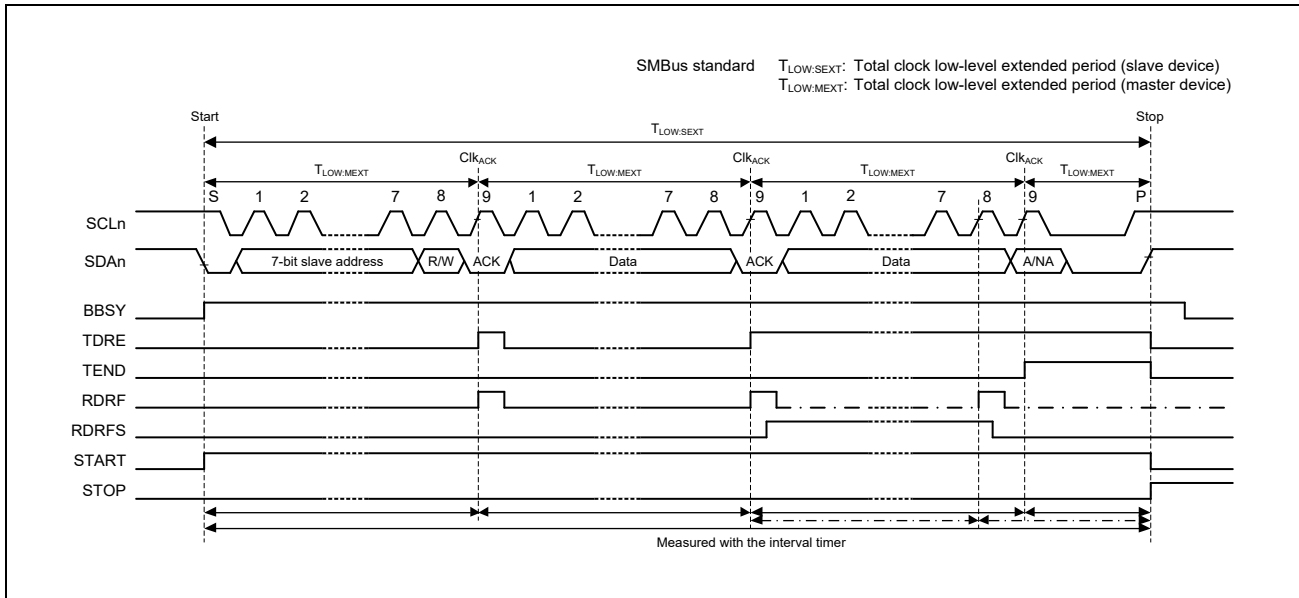

Figure 26.41 SMBus Timeout Measurement

26.14.2 SMBus Host Notification Protocol/Notify ARP Master

In communications over an SMBus, a slave device can temporarily act as a master device to notify the SMBus host (or ARP master) of (or request the SMBus host for) its own slave address or to request its own slave address from the SMBus host.

For this LSI to operate as an SMBus host (or ARP master), the host address (0001 000b) sent from the slave device must be detected as a slave address, so the RIIC has a function for detecting the host address. To detect the host address as a slave address, set the RIICnMR3.SMBS bit and the RIICnSER.HOAE bit to 1. Operation after the host address has been detected is the same as normal slave operation.

26.15 Reset Function of RIIC

The RIIC has chip reset, RIIC reset, and internal reset functions. **Table 26.12** lists the scope of each reset and reset conditions.

Table 26.12 RIIC Reset Functions (1/2)

Register		RIIC Reset (ICE = 0, IICRST = 1)	Internal Reset (ICE = 1, IICRST = 1)	Start Condition/Restart Condition Detection	Stop Condition Detection
RIICnCR1	ICE	0	1	Retained	Retained
	IICRST	1	1	Retained	Retained
	CLO	Initialized	Retained	Retained	Retained
	SOWP	Initialized	Retained	Retained	Retained
	SCLO	Initialized	Initialized	Retained	Retained
	SDAO	Initialized	Initialized	Retained	Retained
	SCLI	Initialized	Retained	Retained	Retained
	SDAI	Initialized	Retained	Retained	Retained
RIICnCR2	BBSY	Initialized	Initialized* ¹	Operation	Retained
	MST	Initialized	Initialized	Operation (retained)	Initialized
	TRS	Initialized	Initialized	Operation (retained)	Initialized
	SP	Initialized	Initialized	Initialized	Initialized
	RS	Initialized	Initialized	Initialized	Initialized
	ST	Initialized	Initialized	Initialized	Retained
RIICnMR1	CKS[2:0]	Initialized	Retained	Retained	Retained
	BCWP	Initialized	Retained	Retained	Retained
	BC[2:0]	Initialized	Initialized	Initialized	Retained
RIICnMR2		Initialized	Retained	Retained	Retained
RIICnMR3	WAIT	Initialized	Retained	Retained	Retained
	RDRFS	Initialized	Retained	Retained	Retained
	ACKWP	Initialized	Retained	Retained	Retained
	ACKBT	Initialized	Retained	Retained	Initialized
	ACKBR	Initialized	Retained	Retained	Retained
	NF[1:0]	Initialized	Retained	Retained	Retained
RIICnFER		Initialized	Retained	Retained	Retained
RIICnSER		Initialized	Retained	Retained	Retained
RIICnIER		Initialized	Retained	Retained	Retained
RIICnSR1	DID	Initialized	Initialized	Retained	Initialized
	GCA	Initialized	Initialized	Retained	Initialized
	AAS2	Initialized	Initialized	Retained	Initialized
	AAS1	Initialized	Initialized	Retained	Initialized
	AAS0	Initialized	Initialized	Retained	Initialized

Table 26.12 RIIC Reset Functions (2/2)

Register		RIIC Reset (ICE = 0, IICRST = 1)	Internal Reset (ICE = 1, IICRST = 1)	Start Condition/Restart Condition Detection	Stop Condition Detection
RIICnSR2	TDRE	Initialized	Initialized	Retained	Initialized
	TEND	Initialized	Initialized	Retained	Initialized
	RDRF	Initialized	Initialized	Retained	Retained
	NACKF	Initialized	Initialized	Retained	Retained
	STOP	Initialized	Initialized	Retained	Operation
	START	Initialized	Initialized	Operation	Initialized
	AL	Initialized	Initialized	Retained	Retained
	TMOF	Initialized	Initialized	Retained	Retained
RIICnSAR0, RIICnSAR1, RIICnSAR2		Initialized	Retained	Retained	Retained
RIICnBRH, RIICnBRL		Initialized	Retained	Retained	Retained
RIICnDRT		Initialized	Retained	Retained	Retained
RIICnDRR		Initialized	Retained	Retained	Retained
RIICnDRS		Initialized	Initialized	Retained	Retained

Note 1. When an internal reset is applied while the bus is free after detection of a stop condition, the setting of the BBSY flag is 0 while the bus is free following de-assertion of the internal reset signal.
When an internal reset is applied while the bus is not free, the BBSY flag is not cleared.

27. Serial Sound Interface (SSIF-2)

27.1 Overview

The serial sound interface (SSIF-2) transmits and receives audio data to and from various devices that are compatible with I²S format, monaural format and TDM format.

27.1.1 Features

Table 27.1 Features of SSIF-2

Item		Description
Number of interfaces		<ul style="list-style-type: none"> • 4
Communication mode		<ul style="list-style-type: none"> • Master/slave • Full-duplex communication is available in interfaces 0, 1, and 3. Half-duplex communication is only available in interface 2.
Communication format		<ul style="list-style-type: none"> • I²S format • Monaural format • TDM format
Serial data		<ul style="list-style-type: none"> • MSB first • Data can be left-justified or right-justified. • Data delay (one clock cycle) or no delay selectable for the period from SSI_RCK to SSI_TXD/SSI_RXD • System word length: 8, 16, 24, 32, 48, 64, 128, or 256 bits • Data word length: 8, 16, 18, 20, 22, 24, or 32 bits • Padding polarity: Low or high
Bit clock (SSIBCK)	In master mode	<ul style="list-style-type: none"> • Clock source division ratio: 1/1, 1/2, 1/4, 1/6, 1/8, 1/12, 1/16, 1/24, 1/32, 1/48, 1/64, 1/96, and 1/128. • Supply/stop of SSI_BCK is selectable while communication is halted.
	In slave mode	<ul style="list-style-type: none"> • SSI_BCK input method: Direct input or via the noise canceller
	In master/slave mode	<ul style="list-style-type: none"> • Polarity: Rising/falling edge canceler
Left and right clock/frame synchronization (SSILRCK/SSIFS)	In master mode	<ul style="list-style-type: none"> • Polarity: Low/high level selectable • Supply/stop of SSI_RCK is selectable while communication is halted.
	In slave mode	<ul style="list-style-type: none"> • Two input methods: Direct input or via the noise canceller
Transmit data (SSITxD) and receive data (SSIRxD)	Transmission	<ul style="list-style-type: none"> • Mute: Transmission of transmit FIFO data or fixed value 0 selectable
	Reception (in slave mode)	<ul style="list-style-type: none"> • Two input methods: Direct input or via the noise canceller
FIFO	Capacity	<ul style="list-style-type: none"> • Transmit FIFO/receive FIFO: 4 bytes × 32 stages, • Receive FIFO: 4 bytes × 32 stages
	Data alignment	<ul style="list-style-type: none"> • Method of data transfer between FIFO and shift register (Left-justification and right-justification) selectable.
Interrupt	Interrupt output	<ul style="list-style-type: none"> • Communication error/idle mode error (level) • Receive data full interrupt (edge) • Transmit data empty interrupt (edge) • Receive data full/transmit data empty interrupt (edge)
	Interrupt capture spilling solution function	<ul style="list-style-type: none"> • Edge Interrupt supports inhibition function of capture spilling.
Low power consumption function		<ul style="list-style-type: none"> • Supply/stop of audio clock is selectable in master-mode communication.

The definition of words and phrases used by the format of the communication of SSIF-2 is as follows.

Table 27.2 Word Definition List

Word	Definition
Start trigger	The first edge that reaches value that set to LRCKP in SSI_RCK pin after SSIF-2 permit communication.
Frame boundary	When SSIF-2 begins to transmit the first data of one frame. When SSIF-2 forwarding ends final data of one frame.
Frame word number	Sound channel number in one frame
System word length	Bit length in one frame.
Data word length	Effective bit length in one frame.
Control bit of communication format	<ul style="list-style-type: none"> • SSICR register: FRM,DWL,SWL,LRCKP,SPDP,SDTA,PDTA,DEL • SSIFCR register: BSW • SSIOFR register: OMOD • SSISCR register: TDES, RDFS

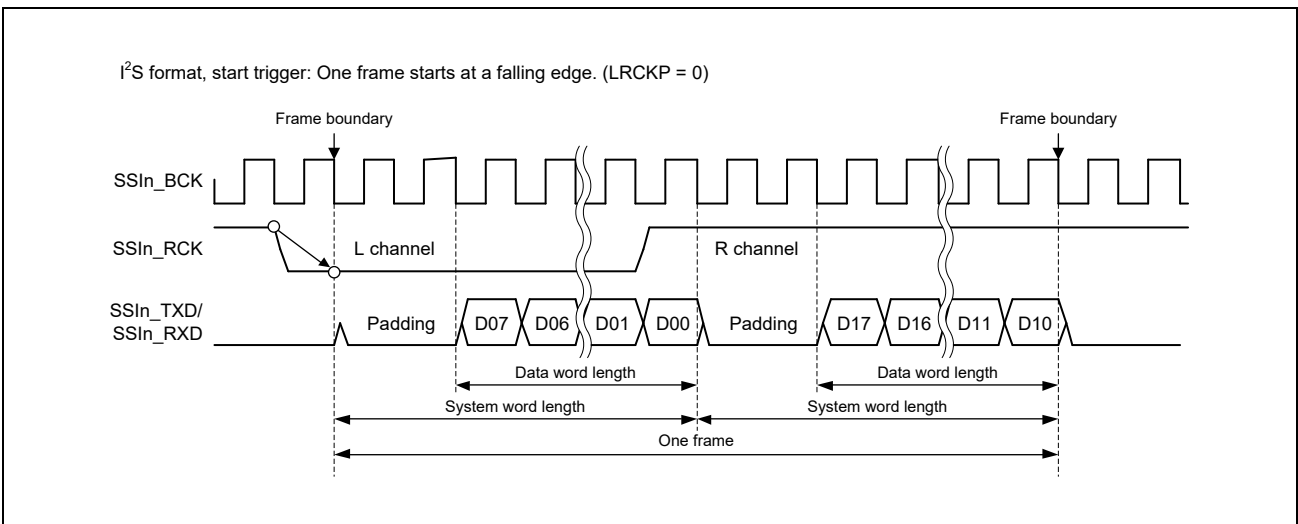

Figure 27.1 Communication Format Definition

27.1.2 Block Diagram

Figure 27.2 shows the block diagram of SSIF-2.

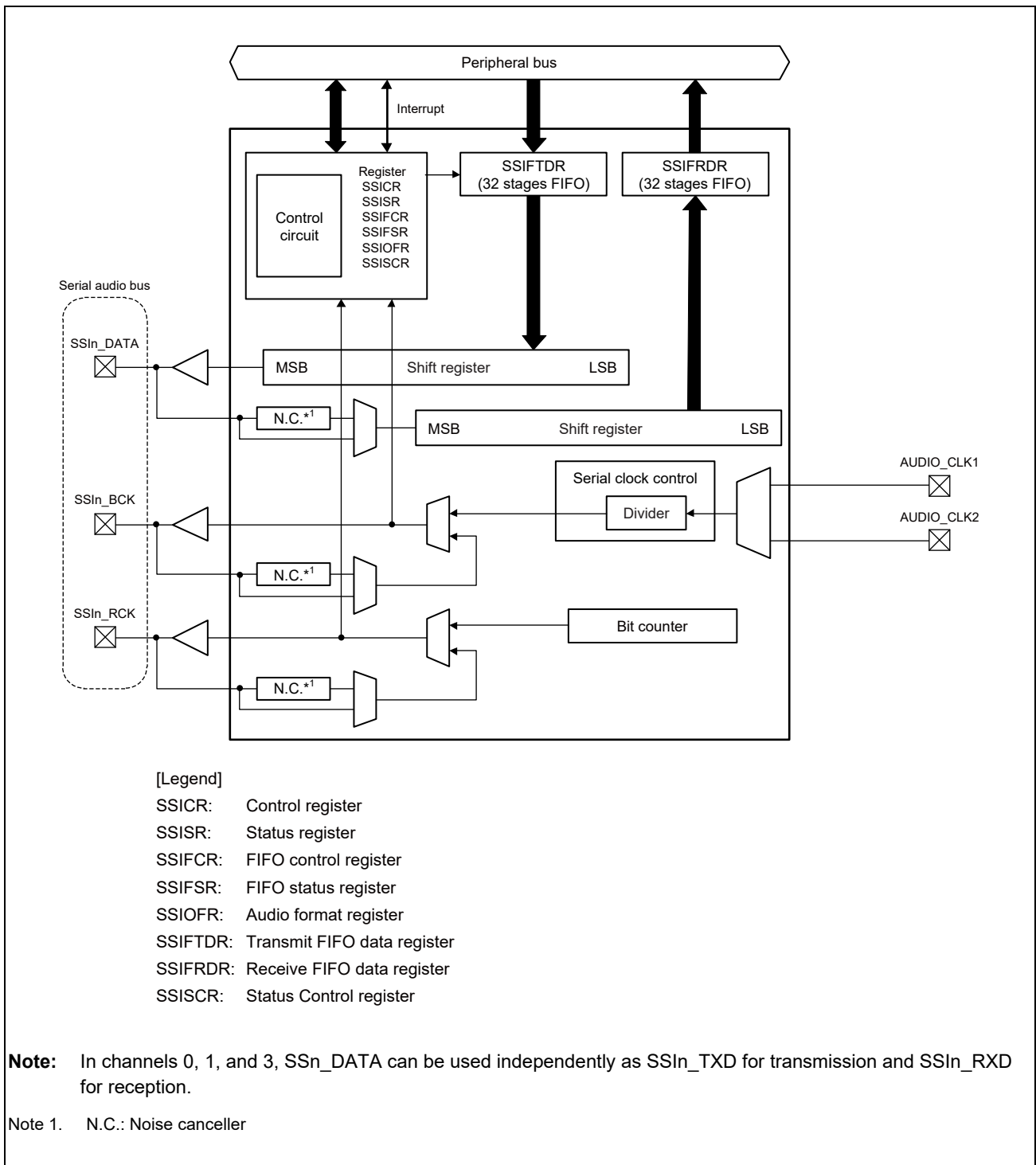

Figure 27.2 SSIF-2 Block Diagram

Figure 27.3 shows the clock configuration of SSIF-2.

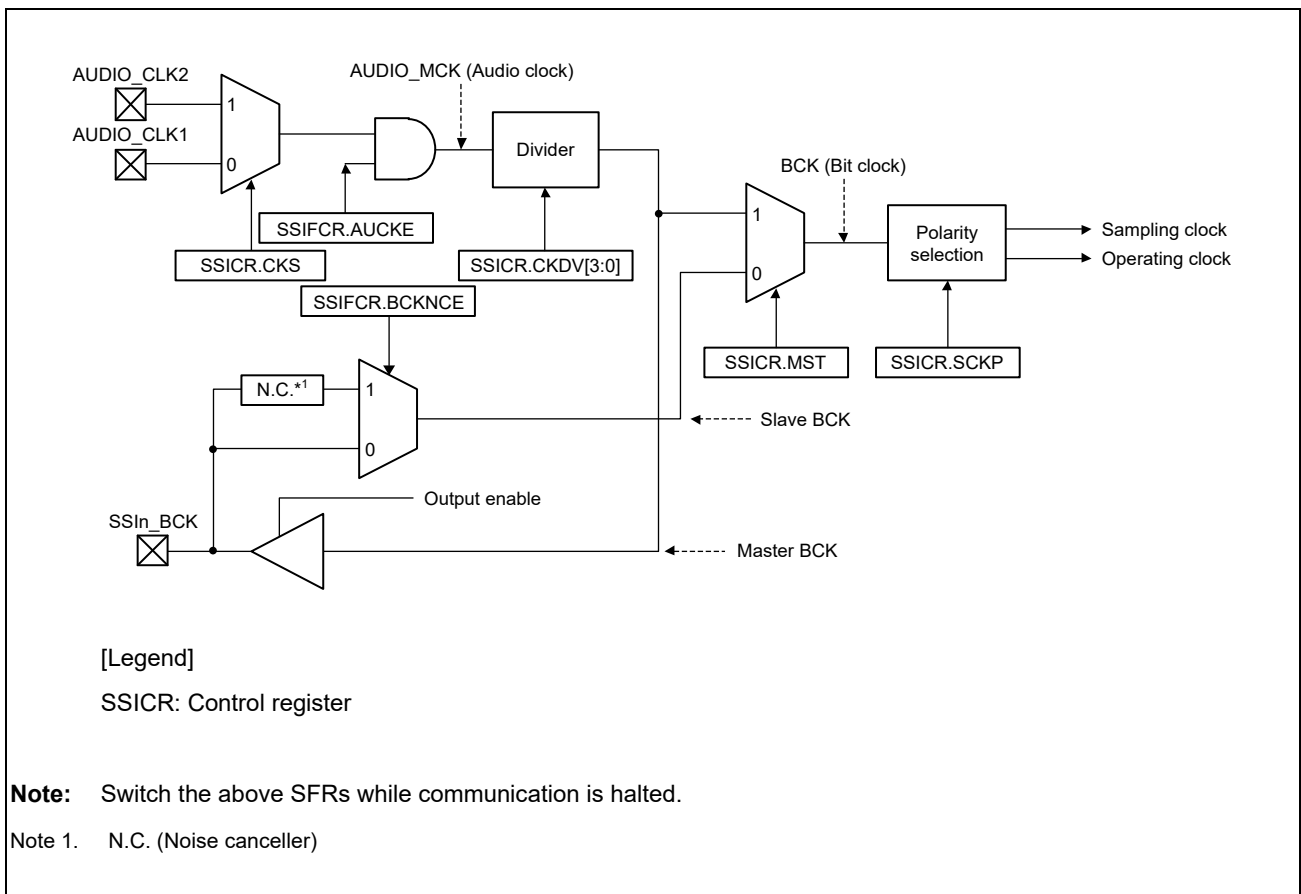

Figure 27.3 SSIF-2 Clock Configuration

27.2 Input/Output Pins

Table 27.3 shows the pin configuration

Table 27.3 Pin Configuration

Interface	name	I/O	Function
0, 1, 3 (n = 0,1,3)	SSIn_BCK	I/O	Bit clock
	SSIn_RCK	I/O	LR clock/frame synchronization
	SSIn_TXD	Output	Serial data output
	SSIn_RXD	Input	Serial data input
2 (n = 2)	SSIn_BCK	I/O	Bit clock
	SSIn_RCK	I/O	LR clock/frame synchronization
	SSIn_DATA	I/O	Serial data I/O
Common	AUDIO_CLK1	Input	External clock1 for audio (The oversampling clock signal is input.)
	AUDIO_CLK2	Input	External clock2 for audio (The oversampling clock signal is input.)

27.3 List of Registers

Table 27.4 shows the register configuration of SSIF-2. The address of the SSIF-2 register is represented by the offset address from the base address. SSIF-2 base address is as follows:

SSIF-2 base address: H'0_1004_9C00 (ch0), H'0_1004_A000 (ch1), H'0_1004_A400 (ch2),
H'0_1004_A800 (ch3) (Overall Address Space)

Table 27.4 List of Control Registers (1/2)

Channel	Register Name	Symbol	R/W	Initial Value	Address	Access Size	
0	Control register	SSICR	RW	H'0000_0000	H'00	32 bits	
	Status register	SSISR	RW	H'0200_0000	H'04	32 bits	
	<i>Note:</i> Bits 31, 30, and 25 to 0 are read only.						
	FIFO control register	SSIFCR	RW	H'0000_0000	H'10	32 bits	
	FIFO status register	SSIFSR	RW	H'0001_0000	H'14	32 bits	
	<i>Note:</i> Bits 31 to 17 and 15 to 1 are read only.						
	Transmit FIFO data register	SSIFTDR	W	H'0000_0000	H'18	32 bits, 16 bits, 8 bits	
	Receive FIFO data register	SSIFRDR	R	H'0000_0000	H'1C	32 bits, 16 bits, 8 bits	
	Audio format register	SSIOFR	RW	H'0000_0000	H'20	32 bits	
	Status control register	SSISCR	RW	H'0000_0000	H'24	32 bits	
1	Control register	SSICR	RW	H'0000_0000	H'00	32 bits	
	Status register	SSISR	RW	H'0200_0000	H'04	32 bits	
	<i>Note:</i> Bits 31, 30, and 25 to 0 are read only.						
	FIFO control register	SSIFCR	RW	H'0000_0000	H'10	32 bits	
	FIFO status register	SSIFSR	RW	H'0001_0000	H'14	32 bits	
	<i>Note:</i> Bits 31 to 17 and 15 to 1 are read only.						
	Transmit FIFO data register	SSIFTDR	W	H'0000_0000	H'18	32 bits, 16 bits, 8 bits	
	Receive FIFO data register	SSIFRDR	R	H'0000_0000	H'1C	32 bits, 16 bits, 8 bits	
	Audio format register	SSIOFR	RW	H'0000_0000	H'20	32 bits	
	Status control register	SSISCR	RW	H'0000_0000	H'24	32 bits	

Table 27.4 List of Control Registers (2/2)

Channel	Register Name	Symbol	R/W	Initial Value	Address	Access Size	
2	Control register	SSICR	RW	H'0000_0000	H'00	32 bits	
	Status register	SSISR	RW	H'0200_0000	H'04	32 bits	
	<i>Note:</i> Bits 31, 30, and 25 to 0 are read only.						
	FIFO control register	SSIFCR	RW	H'0000_0000	H'10	32 bits	
	FIFO status register	SSIFSR	RW	H'0001_0000	H'14	32 bits	
	<i>Note:</i> Bits 31 to 17 and 15 to 1 are read only.						
	Transmit FIFO data register	SSIFTDR	W	H'0000_0000	H'18	32 bits, 16 bits, 8 bits	
	Receive FIFO data register	SSIFRDR	R	H'0000_0000	H'1C	32 bits, 16 bits, 8 bits	
	Audio format register	SSIOFR	RW	H'0000_0000	H'20	32 bits	
	Status control register	SSISCR	RW	H'0000_0000	H'24	32 bits	
3	Control register	SSICR	RW	H'0000_0000	H'00	32 bits	
	Status register	SSISR	RW	H'0200_0000	H'04	32 bits	
	<i>Note:</i> Bits 31, 30, and 25 to 0 are read only.						
	FIFO control register	SSIFCR	RW	H'0000_0000	H'10	32 bits	
	FIFO status register	SSIFSR	RW	H'0001_0000	H'14	32 bits	
	<i>Note:</i> Bits 31 to 17 and 15 to 1 are read only.						
	Transmit FIFO data register	SSIFTDR	W	H'0000_0000	H'18	32 bits, 16 bits, 8 bits	
	Receive FIFO data register	SSIFRDR	R	H'0000_0000	H'1C	32 bits, 16 bits, 8 bits	
	Audio format register	SSIOFR	RW	H'0000_0000	H'20	32 bits	
	Status control register	SSISCR	RW	H'0000_0000	H'24	32 bits	

Note: Access to the addresses other than those listed above is prohibited.

27.4 Function Details

27.4.1 Register Descriptions

27.4.1.1 Control Register (SSICR)

This is a 32-bit readable/writable register. With this register, select an audio clock, control IRQ, select data formats, and set an operation mode.

Bit	31	30	29	28	27	26	25	24	23	22	21	20	19	18	17	16
	—	CKS	TUIEN	TOIEN	RUIEN	ROIEN	IEN	—	FRM[1:0]		DWL[2:0]				SWL[2:0]	
Initial Value	0	0	0	0	0	0	0	0	0	0	0	0	0	0	0	0
R/W	R	R/W	R/W	R/W	R/W	R/W	R/W	R	R/W	R/W	R/W	R/W	R/W	R/W	R/W	R/W
Bit	15	14	13	12	11	10	9	8	7	6	5	4	3	2	1	0
	—	MST	BCKP	LRCKP	SPDP	SDTA	PDTA	DEL		CKDV[3:0]			MUEN	—	TEN	REN
Initial Value	0	0	0	0	0	0	0	0	0	0	0	0	0	0	0	0
R/W	R	R/W	R/W	R/W	R/W	R/W	R/W	R/W	R/W	R/W	R/W	R/W	R/W	R	R/W	R/W

Bit	Bit Name	Initial Value	R/W	Description
31	—	0	R	Reserved. Write 0. The read value is 0.
30	CKS	0	RW	Selects an audio clock for master-mode communication*1 0: Selects the AUDIO_CLK2 input 1: Selects the AUDIO_CLK1 input
29	TUIEN	0	RW	Transmit underflow interrupt output enable 0: Disables transmit underflow interrupt output 1: Enables transmit underflow interrupt output
28	TOIEN	0	RW	Transmit overflow interrupt output enable 0: Disables transmit overflow interrupt output 1: Enables transmit overflow interrupt output
27	RUIEN	0	RW	Receive underflow interrupt output enable 0: Disables receive underflow interrupt output 1: Enables receive underflow interrupt output
26	ROIEN	0	RW	Receive overflow interrupt output enable 0: Disables receive overflow interrupt output 1: Enables receive overflow interrupt output
25	IEN	0	RW	Idle mode interrupt output enable 0: Disables idle mode interrupt output 1: Enables idle mode interrupt output
24	—	0	R	Reserved. Write 0. The read value is 0.
23, 22	FRM[1:0]	00b	RW	Select frame word number*1
Communication format (SSIOFR.OMOD[1:0])				
	FRM[1:0]	I ² S (00b)	Monaural (10b)	TDM (01b)
	00b	2	1	Set prohibition
	01b	Set	Set prohibition	4
	10b	prohibition		6
	11b			8

Bit	Bit Name	Initial Value	R/W	Description
21 to 19	DWL[2:0]	000b	R/W	Selects data word length*1 000: 8 bits 001: 16 bits 010: 18 bits 011: 20 bits 100: 22 bits 101: 24 bits 110: 32 bits 111: Setting prohibited
18 to 16	SWL[2:0]	000b	RW	Selects system word length*1 000: 8 bits 001: 16 bits 010: 24 bits 011: 32 bits 100: 48 bits 101: 64 bits 110: 128 bits 111: 256 bits
15	—	0	R	Reserved. Write 0. The read value is 0.
14	MST	0	RW	Master enable*1 0: Slave-mode communication 1: Master-mode communication
13	BCKP	0	RW	Selects bit clock polarity*1 0: SSILRCK/SSIFS and SSIFTxD/SSIFRxD change at a falling edge (sampling SSILRCK/SSIFS and SSIFRxD at a rising edge of SSIBCK). 1: SSILRCK/SSIFS and SSIFTxD/SSIFRxD change at a rising edge (sampling SSILRCK/SSIFS and SSIFRxD at a falling edge of SSIBCK).
12	LRCKP	0	RW	Selects the initial value and polarity of LRCK/FS*1 0: The initial value is at a high level For SSILRCK/SSIFS, one frame start trigger is falling edge of SSILRCK/SSIFS. 1: The initial value is at a low level For SSILRCK/SSIFS, one frame start trigger is rising edge of SSILRCK/SSIFS.
11	SPDP	0	RW	Selects serial padding polarity*1 0: Padding data is at a low level 1: Padding data is at a high level
10	SDTA	0	RW	Selects serial data alignment*1 0: Transmits and receives serial data first and then padding bits. 1: Transmit and receives padding bits first and then serial data.
9	PDTA	0	RW	Selects placement data alignment*1 0: Left-justifies placement data (SSIFTDR, SSIFRDR) 1: Right-justifies placement data (SSIFTDR, SSIFRDR)
8	DEL	0	RW	Selects serial data delay*1 0: Delay of one cycle of SSIBCK between SSILRCK/SSIFS and SSIFTxD/SSIFRxD. 1: No delay between SSILRCK/SSIFS and SSIFTxD/SSIFRxD. This bit control SSILRCK/SSIFS in monaural format (Refer to Section 27.4.2.2, Monaural Format for details).

Bit	Bit Name	Initial Value	R/W	Description
7 to 4	CKDV[3:0]	H'0	RW	Selects bit clock division ratio*1 CKDV[3:0] 0000: AUDIO_MCK 0001: AUDIO_MCK/2 0010: AUDIO_MCK/4 0011: AUDIO_MCK/8 0100: AUDIO_MCK/16 0101: AUDIO_MCK/32 0110: AUDIO_MCK/64 0111: AUDIO_MCK/128 1000: AUDIO_MCK/6 1001: AUDIO_MCK/12 1010: AUDIO_MCK/24 1011: AUDIO_MCK/48 1100: AUDIO_MCK/96 1101: Setting prohibited 1110: Setting prohibited 1111: Setting prohibited
3	MUEN	0	RW	Mute (silent) enable 0: Disables muting on the next frame boundary. 1: Enables muting on the next frame boundary.
2	—	0	R	Reserved. Write 0. The read value is 0.
1	TEN	0	RW	Transmission and reception enable*2
0	REN	0	RW	(TEN, REN): Operating 00: Disables transmission and reception 01: Enables reception (starts reception) 10: Enables transmission (starts transmission) 11: Enables transmission and reception (starts transmission and reception)

Note 1. Writing to these bits while SSIF-2 is in a communication state (SSISR.IIRQ = 0) is prohibited. If written, the operation performed immediately after writing is not guaranteed.

Note 2. If the TEN bit or REN bit is rewritten, make sure that the SSISR.IIRQ bit is in the desired status. If written, the operation performed immediately after writing is not guaranteed. For example, after enabling operation, make sure that SSISR.IIRQ = 0 and after disabling operation, make sure that SSISR.IIRQ = 1.

CKS Bit

This bit sets the audio clock in master-mode communication (MST = 1). In slave-mode communication (MST = 0), setting of this bit is invalid.

To write this bit, do so when AUDIO_MCK is not supplied. Refer to the AUCKE bit details explanation in **Section 27.4.1.3, FIFO Control Register (SSIFCR)** for detailed timing.

TUIEN Bit

This bit enables/disables output of transmit underflow interrupts. By enabling this bit (set it to 1), an interrupt is output at a rising edge of SSISR.TUIRQ = 1. An interrupt is also output when this bit is changed from 0 to 1 while SSISR.TUIRQ = 1.

TOIEN Bit

This bit enables/disables output of transmit overflow interrupts. By enabling this bit (set it to 1), an interrupt is output at a rising edge of SSISR.TOIRQ = 1. An interrupt is also output when this bit is changed from 0 to 1 while SSISR.TOIRQ = 1.

RUIEN Bit

This bit enables/disables output of receive underflow interrupts. By enabling this bit (set it to 1), an interrupt is output at a rising edge of $SSISR.RUIRQ = 1$. An interrupt is also output when this bit is changed from 0 to 1 while $SSISR.RUIRQ = 1$.

ROIEN Bit

This bit enables/disables output of receive overflow interrupts. By enabling this bit (set it to 1), an interrupt is output at a rising edge of $SSISR.ROI RQ = 1$. An interrupt is also output when this bit is changed from 0 to 1 while $SSISR.ROI RQ = 1$.

I IEN Bit

This bit enables/disables output of idle mode interrupts. By enabling this bit (set it to 1), an interrupt is output at a rising edge of $SSISR.IIRQ = 1$. An interrupt is also output when this bit is changed from 0 to 1 while $SSISR.IIRQ = 1$.

FRM[1:0] Bits

These bits set system word number in one frame of the communication formats.

Rewrite these bits when the LR clock supply to the terminal SSILRCK stops. Refer to the LRCONT bit details explanation in **Section 27.4.1.7, Audio Format Register (SSIOFR)** for the output operation of the LR clock.

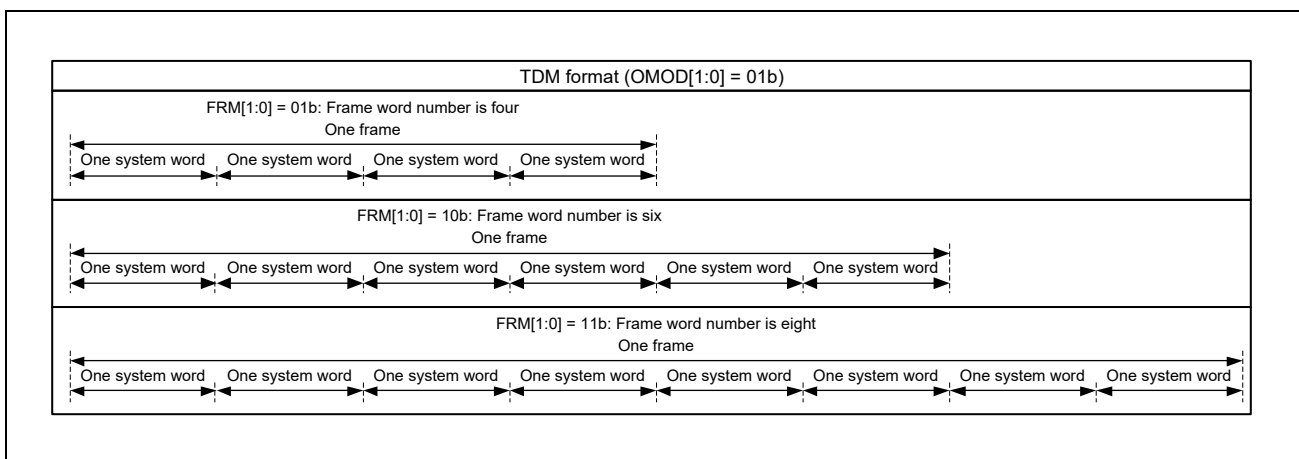

Figure 27.4 Frame word number

DWL[2:0] Bits

These bits set the number of bits in one data word. The setting whose number of data of system word lengths is shorter than that of the data word length is a prohibition. Refer to **Table 27.13** in **Section 27.4.2, Communication Formats** for details.

SWL[2:0] Bits

These bits set the number of bits in one system word. Padding bits are sent and received in relation with one data word set with DWL[2:0]. See **Table 27.13** in **Section 27.4.2, Communication Formats** for details.

Rewrite these bits when the LR clock supply to the terminal SSILRCK stops. Refer to the LRCONT bit details explanation in **Section 27.4.1.7, Audio Format Register (SSIOFR)** for the output operation of the LR clock.

MST Bit

This bit sets master-/slave-mode communication.

To write this bit, do so when AUDIO_MCK is not supplied. Refer to the AUCKE bit details explanation in **Section 27.4.1.3, FIFO Control Register (SSIFCR)** for detailed timing.

BCKP Bit

This bit sets the bit clock polarity (**Table 27.5**).

To write this bit, do so when AUDIO_MCK is not supplied. Refer to the AUCKE bit details explanation in **Section 27.4.1.3, FIFO Control Register (SSIFCR)** for detailed timing.

Table 27.5 Bit Clock Polarity

Communication	Master/Slave	Timing	BCKP = 0	BCKP = 1
Reception	Slave	At SSILRCK/SSIFS sampling	SSIBCK rising edge	SSIBCK falling edge
	Master/slave	At SSIFRxD sampling	SSIBCK rising edge	SSIBCK falling edge
Transmission	Master	At change of SSILRCK/SSIFS output	SSIBCK falling edge	SSIBCK rising edge
	Master/slave	At change of SSIFTxD output	SSIBCK falling edge	SSIBCK rising edge

LRCKP Bit

This bit sets the initial value and polarity of SSILRCK/SSIFS. Set this bit according to the communication format to be used in SSIF-2 (**Table 27.6**). Only the start trigger is used at slave communication (MST=0).

Rewrite this bit when the LR clock supply to the terminal SSILRCK stops. Refer to the LRCONT bit details explanation in **Section 27.4.1.7, Audio Format Register (SSIOFR)** for the output operation of the LR clock.

Table 27.6 Initial Output Value and Polarity of SSILRCK/SSIFS Pin

Communication Format	Expected Initial State	Setting Value of LRCKP
I ² S	H	0
Monaural	L	1
TDM	L	1

Note: Do the setting that can be communicated respectively to I²S, monaural, and TDM at the compatible format.

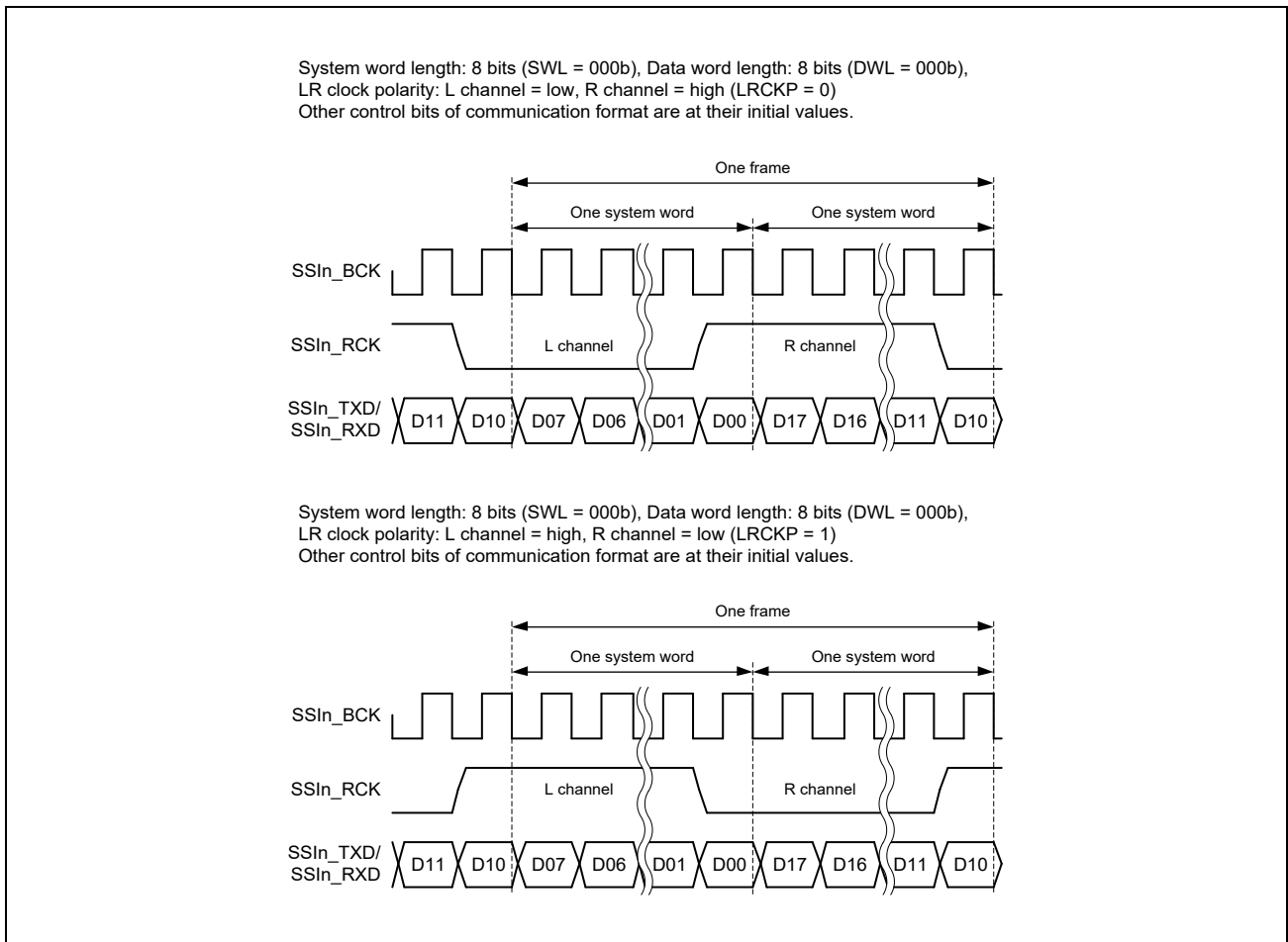

Figure 27.5 LRCK/FS Polarity Setting

SPDP Bit

This bit sets polarity of padding bits.

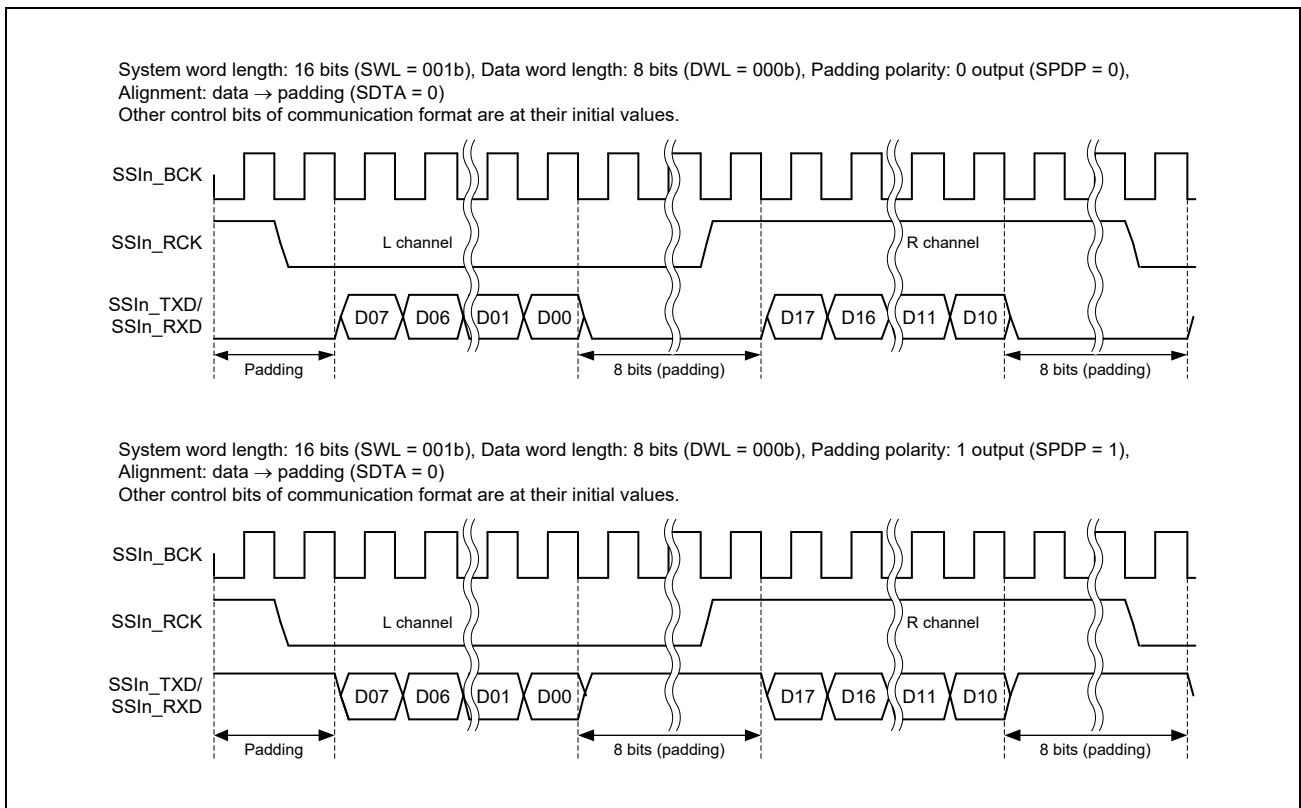

Figure 27.6 Padding Bit Polarity

SDTA Bit

This bit sets alignment of serial data (data bits and padding bits). For communication without padding bits, this bit is invalid.

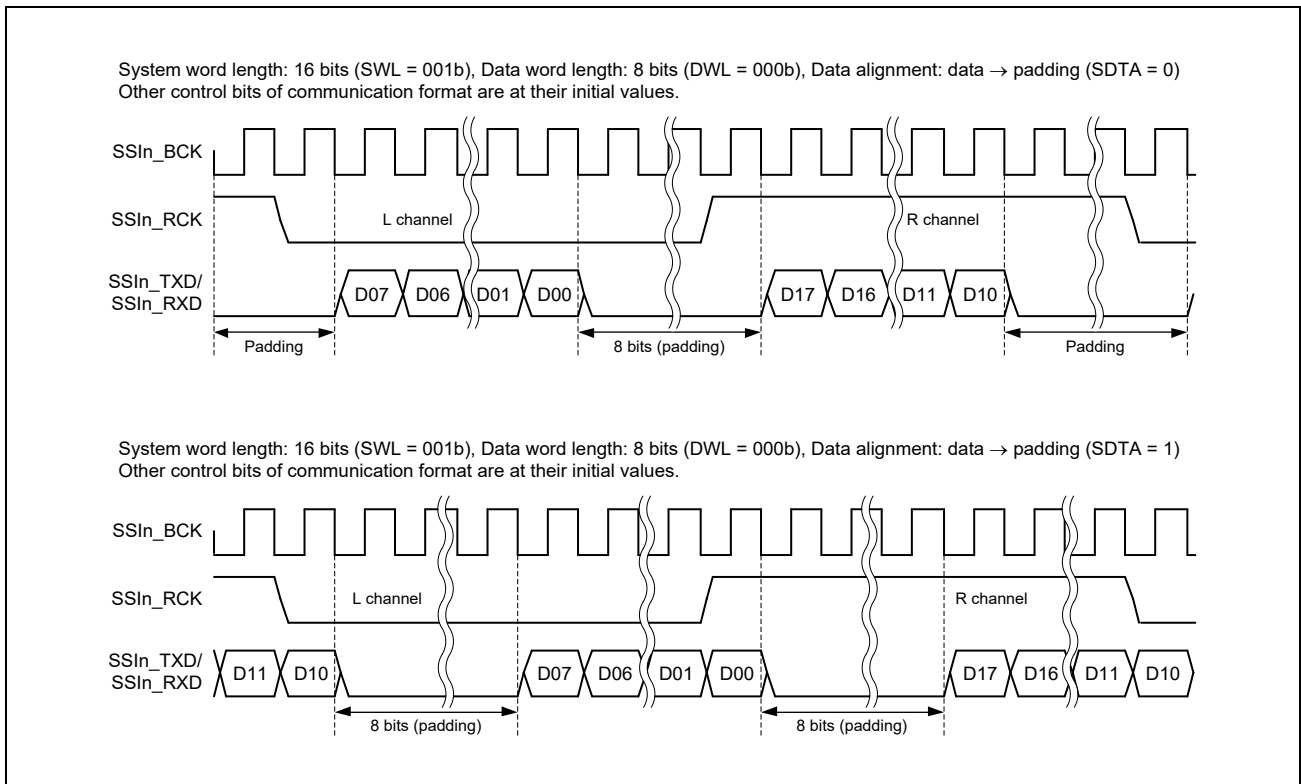

Figure 27.7 Alignment Setting of Serial Data with Padding Bits

PDTA Bit

This bit sets alignment of placement data. With the setting of data word length as 32 bits (DWL[2:0] = 110b), this bit is invalid.

At transmission:

		First transfer data	Second transfer data	Third transfer data	Fourth transfer data	
DWL [2:0]	SSIFTDR				Transmission shift register	
	PDTA = 0 (Left aligned)		PDTA = 1 (Right aligned)			
000 (8-bit)		7	0	Disable		
		7	0	Disable		
		7	0	Disable		
		7	0	Disable		
001 (16-bit)		15	0	Disable		
		15	0	Disable		
		15	0	Disable		
		15	0	Disable		
010 to 101 18-bit: X = 17 20-bit: X = 19 22-bit: X = 21 24-bit: X = 23		X	0	Disable		
		X	0	Disable		
		X	0	Disable		
		X	0	Disable		
110 (32-bit)		31	0	Disable		
		31	0	Disable		
		31	0	Disable		
		31	0	Disable		
111 (setting prohibited)	Setting prohibited					

Figure 27.8 Alignment Setting of Placement Data in Transmission

At reception:

		First transfer data	Second transfer data	Third transfer data	Fourth transfer data
DWL [2:0]	Reception shift register	SSIFRDR			
		PDTA = 0 (Left aligned)		PDTA = 1 (Right aligned)	
000 (8-bit)	Disable	7	0	7	0
	Disable	7	0	7	0
		7	0	7	0
		7	0	7	0
		Setting prohibited			
001 (16-bit)		15	0	15	0
		15	0	15	0
		15	0	15	0
		15	0	15	0
		Setting prohibited			
010 to 101 18-bit: X = 17 20-bit: X = 19 22-bit: X = 21 24-bit: X = 23	X	X	0	X	0
	X	X	0	X	0
	X	X	0	X	0
	X	X	0	X	0
110 (32-bit)	31	31	0	31	0
	31	31	0	31	0
	31	31	0	31	0
	31	31	0	31	0
		Setting prohibited			
111 (setting prohibited)	Setting prohibited				

Figure 27.9 Alignment Setting of Placement Data in Reception

DEL Bit

This bit sets whether or not there will be a delay between SSILRCK/SSIFS and SSITxD/SSIRxD.

With the I²S format and TDM format, set 0 to DEL (**Figure 27.10**). With the monaural format, this bit changes the high period width. Refer to **Section 27.4.2.2, Monaural Format** for details. Do the setting that can be communicated at the compatible communication format.

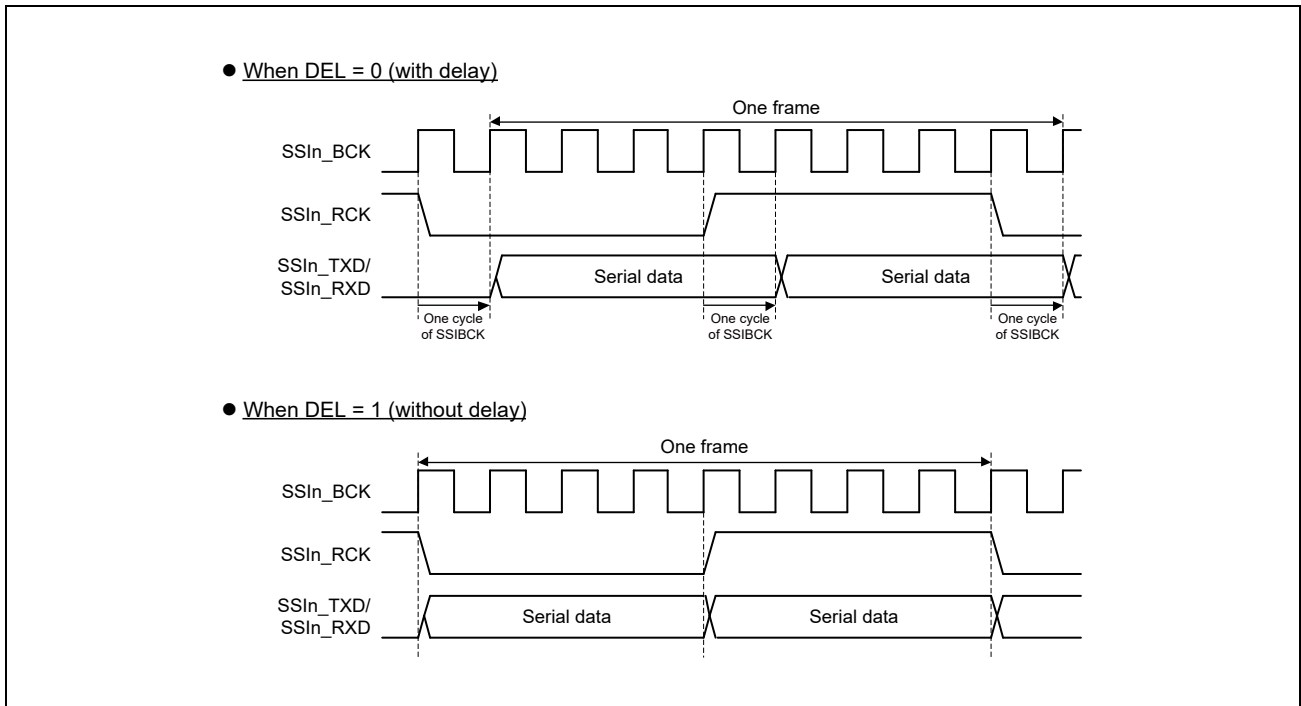

Figure 27.10 Setting of Delay in Serial Data

CKDV[3:0] Bits

These bits set the division ratio of the bit clock based on AUDIO_MCK in master-mode communication (MST = 1) (**Figure 27.11**). In slave-mode communication (MST = 0), setting of these bits are invalid.

To write this bit, do so when AUDIO_MCK is not supplied. Refer to the AUCKE bit details explanation in **Section 27.4.1.3, FIFO Control Register (SSIFCR)** for detailed timing.

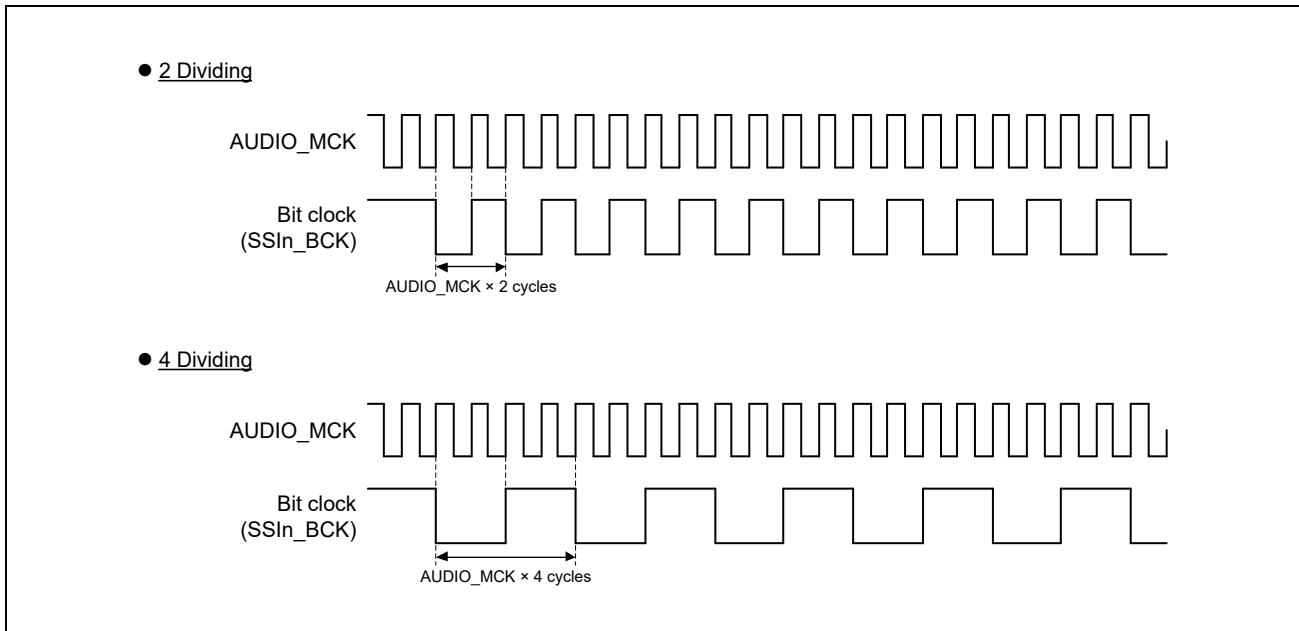

Figure 27.11 Sampling Frequencies in Master-mode Communication

MUEN Bit

This bit sets/clears the mute function for the data output from the terminal SSITxD. When you set this bit to 1, the output value of SSITxD becomes 0 from the next frame boundary. When you set this bit to 0, the output value of SSITxD can be made the data of the FIFO transmission data register from the following frame boundary.

Note that this bit controls data only. Status flags and interrupt signals are normally generated. Set this bit after setting completing the communication format.

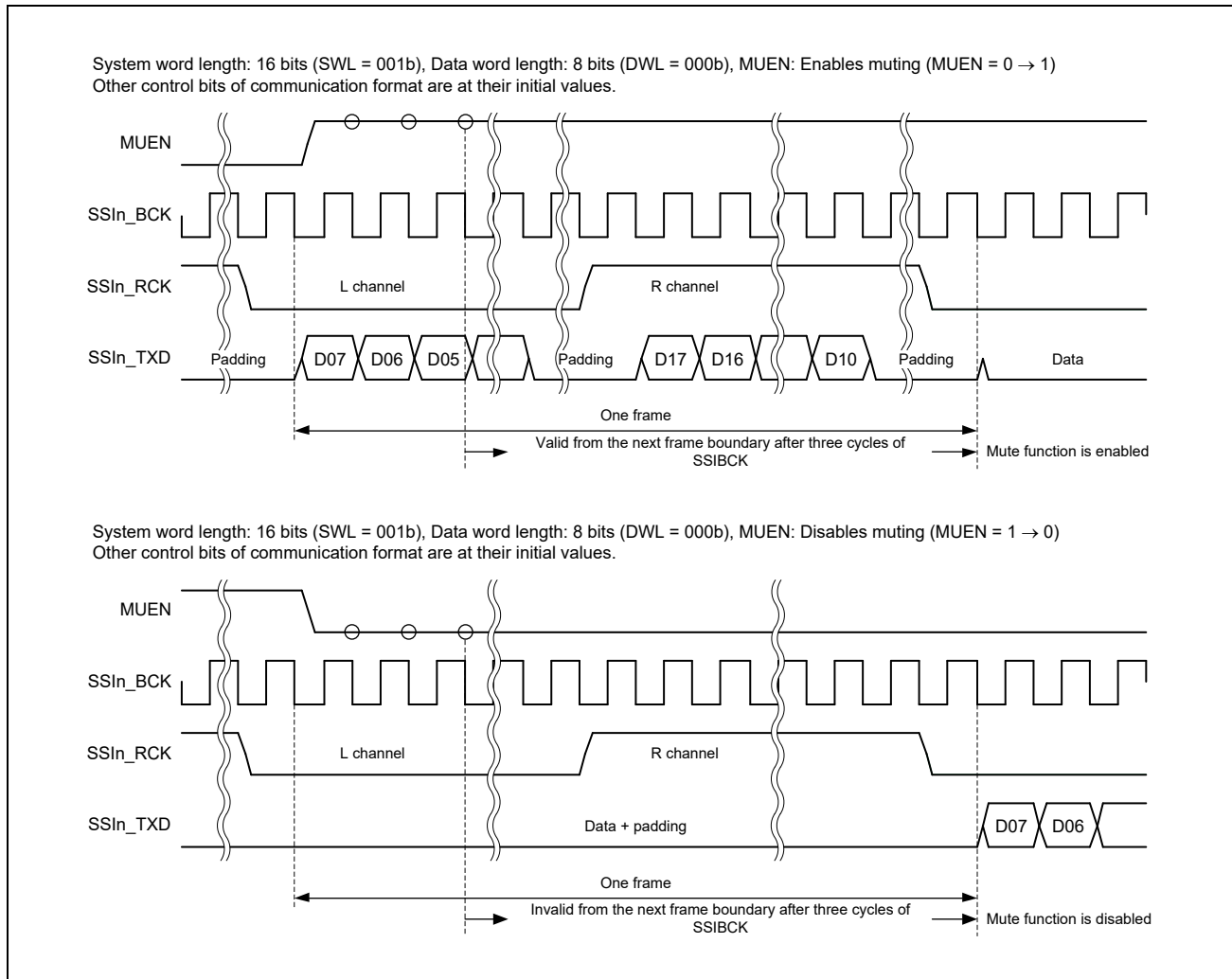

Figure 27.12 Transmit Data with the Mute Function Set

TEN and REN Bits

These bits enable/disable transmission and reception. Writing 1 to these bits, transmission starts in synchronization with start trigger. Refer to **Section 27.5.2.2, Transmission**, **Section 27.5.2.3, Reception**, and **Section 27.5.2.4, Transmission and Reception** for details. Writing 0 to these bits, transmission stops in synchronization with next frame boundary. Set 1 at the same time when you use SSIF-2 as transmission and reception. To stop communication, make sure to stop transmission and reception (TEN = 0 and REN = 0).

To stop communication without waiting for the frame boundary, follow the software reset procedure.

27.4.1.2 Status Register (SSISR)

This is a readable/writable 32-bit register. It is configured with status flags that indicate SSIF-2 operational state.

Bit	31	30	29	28	27	26	25	24	23	22	21	20	19	18	17	16
	—	—	TUIRQ	TOIRQ	RUIRQ	ROIRQ	IIRQ	—	—	—	—	—	—	—	—	—
Initial Value	0	0	0	0	0	0	1	0	0	0	0	0	0	0	0	0
R/W	R	R	R/W0	R/W0	R/W0	R/W0	R	R	R	R	R	R	R	R	R	R
Bit	15	14	13	12	11	10	9	8	7	6	5	4	3	2	1	0
	—	—	—	—	—	—	—	—	—	—	—	—	—	—	—	—
Initial Value	0	0	0	0	0	0	0	0	0	0	0	0	0	0	0	0
R/W	R	R	R	R	R	R	R	R	R	R	R	R	R	R	R	R

Bit	Bit Name	Initial Value	R/W	Description
31, 30	—	00b	R	Reserved. Write 0. The read value is 0.
29	TUIRQ	0	RW0	Transmit underflow error status flag 0: No transmit underflow error is generated. 1: A transmit underflow error is generated.
28	TOIRQ	0	RW0	Transmit overflow error status flag 0: No transmit overflow error is generated. 1: A transmit overflow error is generated.
27	RUIRQ	0	RW0	Receive underflow error status flag 0: No receive underflow error is generated. 1: A receive underflow error is generated.
26	ROIRQ	0	RW0	Receive overflow error status flag 0: No receive overflow error is generated. 1: A receive overflow error is generated.
25	IIRQ	1	R	Idle mode status flag 0: In the communication state 1: In the idle state
24 to 0	—	H'000000 0	R	Reserved. Write 0. The read value is 0.

TUIRQ Bit

This is a status flag that indicates a transmit underflow error. This flag is set by automatic determination but it must be cleared by register access. This flag indicates that writing serial data necessary for one frame to SSIFTDR was slower than one frame of the transmission operation. Even if this flag is cleared after this flag becomes '1', the output value of SSIFTxD is 0. Follow the communication stop procedure (**Figure 27.55**) and the error procedure (**Figure 27.56**) to output the data written in transmission FIFO data register (SSIFTDR) to the terminal SSIFTxD. See **Section 27.5.2.6, Error Handling** for the error recovery procedure. This flag is not cleared by transmission FIFO data register reset (SSIFCR.TFRST).

[Priority order for setting and clearing]

Setting is prioritized.*1

[Clearing condition]

When either of the following is approved.

- (1) Writing 0 to this flag after reading this flag as 1.*2
- (2) When you do the communication permission (SSICR.TEN is changed from 0 to 1)

[Clearing timing]

Timing according to the above-mentioned clear condition.

- (1) At completion of writing 0 to this flag after reading this flag as 1 (**Figure 27.13**).
- (2) Write 1 in SSICR.TEN, complete, and after one cycle of P0φ (**Figure 27.13**).

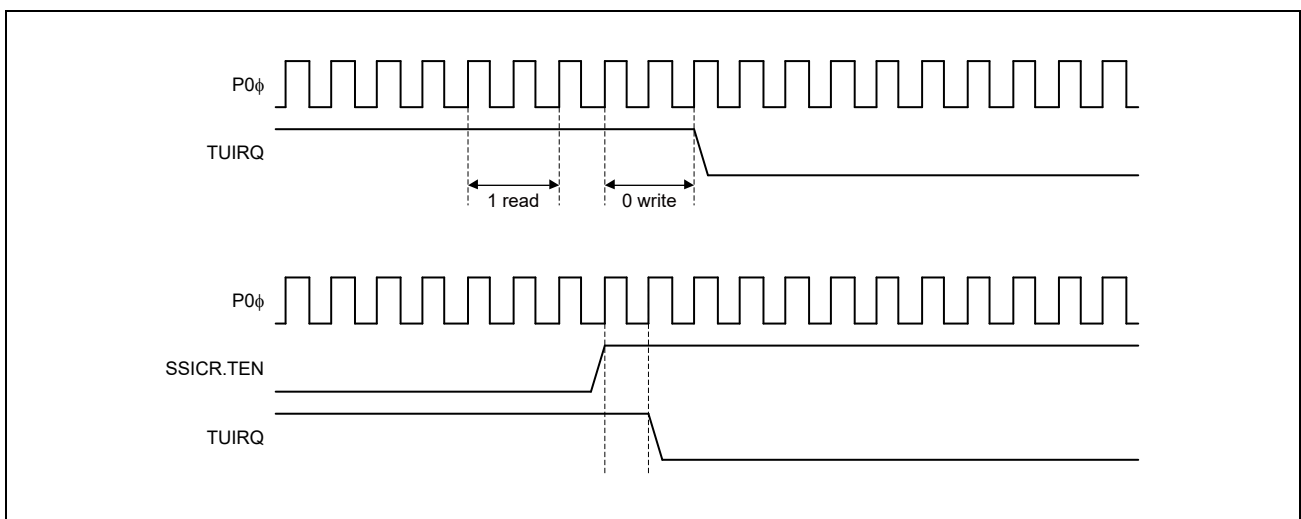

Figure 27.13 TUIRQ Clearing Timing

Note 1. This bit is also cleared by a software reset (SSIFCR.SSIRST = 1). The software reset has priority over all the clearing conditions described above.

Note 2. The state of reading this bit as one is cleared by any of the following three conditions being met:

- Software reset (SSIFCR.SSIRST=1).
- Completion of writing 0 to this flag after having read it as 1.
- One cycle of P0φ elapsing after the completion of writing 1 to SSICR.TEN.

NOTE

After the communication is permitted (SSICR.TEN is written and '1' is written from '0'), the transmission error flag (TOIRQ and TUIRQ of the SSISR register) is cleared. However, when the SSISR register is continuously read, the clearness of the transmission error flag might not be able to be read.

[Setting condition]

When data to be transmitted in the next frame is not fully written to SSIFTDR at the frame boundary of continuance communication.

[Setting timing]

After three cycles of P0φ from frame boundary (**Figure 27.14**).

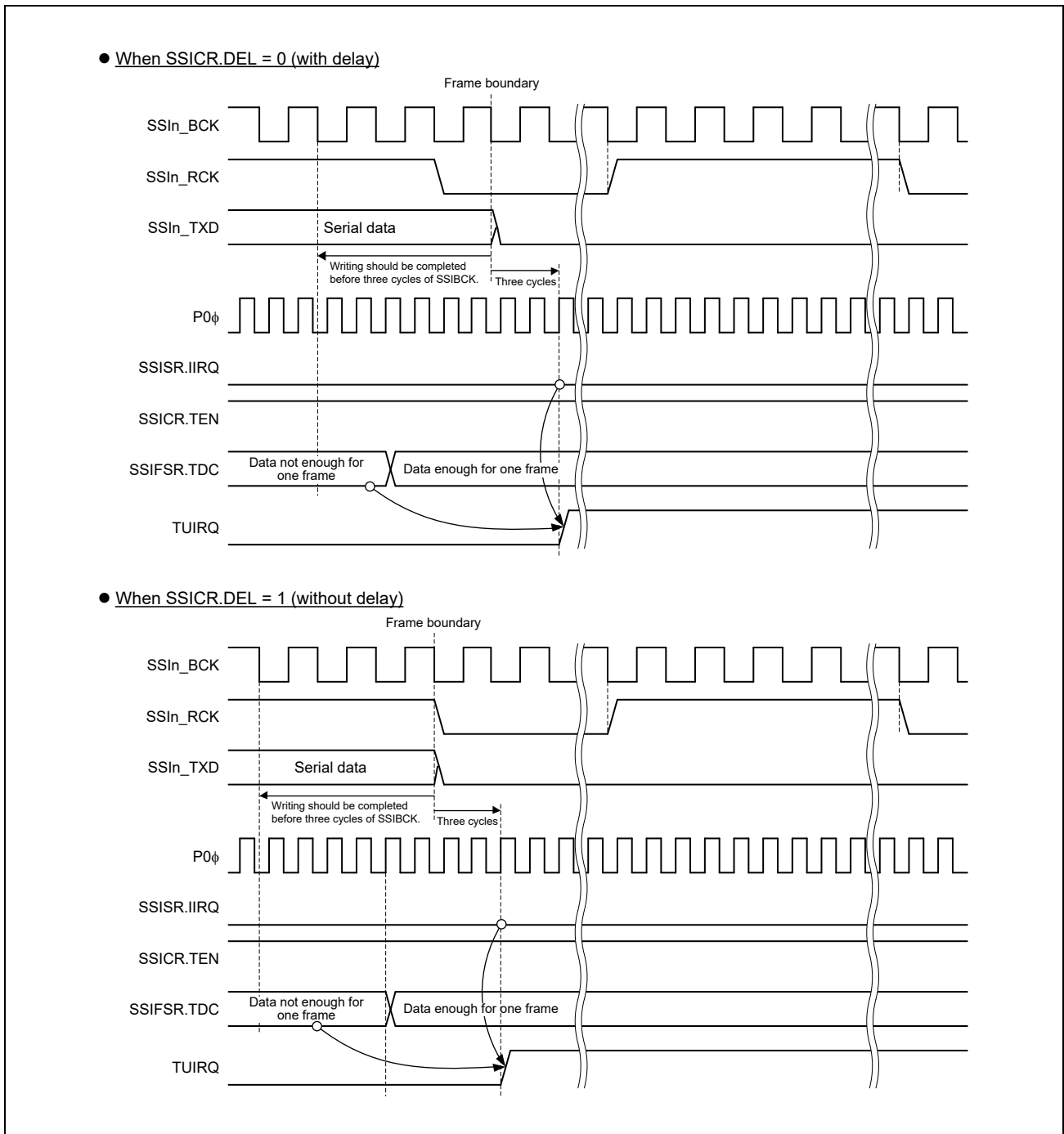

Figure 27.14 TUIRQ Setting Timing (When you continue communicating)

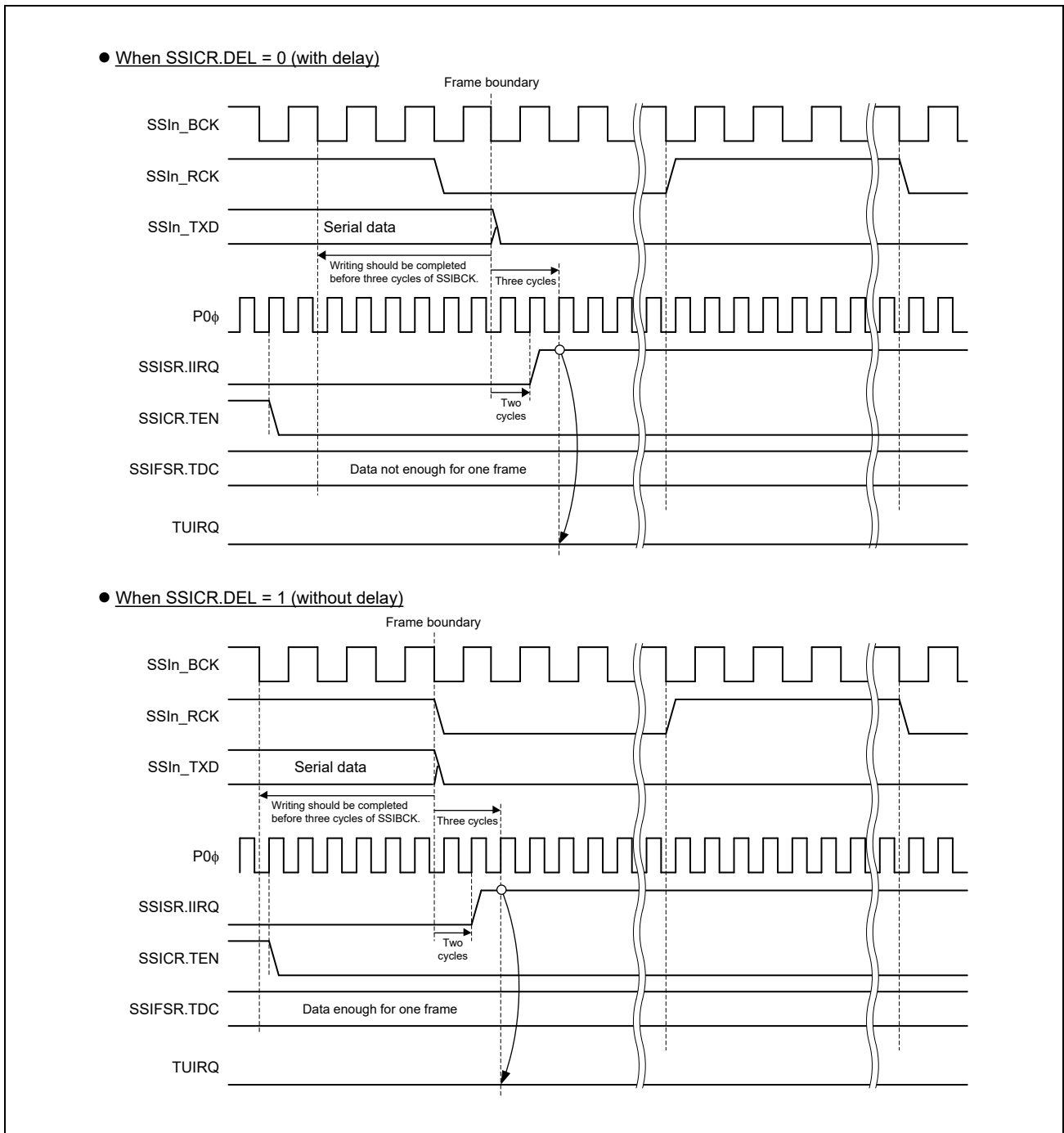

Figure 27.15 TUIRQ Setting Timing (When you stop communicating)

TOIRQ Bit

This is a status flag that indicates a transmit overflow error. This flag is set by automatic determination but it must be cleared by register access. This flag indicates that serial data is written to SSIFTDR when it is full during transmission (SSICR.TEN=1). Data is not written to SSIFTDR where a transmit overflow error is generated. See **Section 27.5.2.6, Error Handling** for the error recovery procedure. This flag is not cleared by transmission FIFO data register reset (SSIFCR.TFRST).

[Priority order for setting and clearing]

Setting is prioritized.*¹

[Clearing condition]

When either of the following is approved.

- (1) Writing 0 to this flag after reading this flag as 1.*²
- (2) When you do the communication permission (SSICR.TEN is changed from 0 to 1)

[Clearing timing]

Timing according to the above-mentioned clear condition.

- (1) At completion of writing 0 to this flag after reading this flag as 1 (same as **Figure 27.13**).
- (2) Write 1 in SSICR.TEN, complete, and after one cycle of P0 ϕ (same as **Figure 27.13**).

Note 1. This bit is also cleared by a software reset (SSIFCR.SSIRST = 1). The software reset has priority over all the clearing conditions described above.

Note 2. The state of reading this bit as one is cleared by any of the following three conditions being met:

- Software reset (SSIFCR.SSIRST=1).
- Completion of writing 0 to this flag after having read it as 1.
- One cycle of P0 ϕ elapsing after the completion of writing 1 to SSICR.TEN.

NOTE

After the communication is permitted (SSICR.TEN is written and '1' is written from '0'), the transmission error flag (TOIRQ and TUIRQ of the SSISR register) is cleared. However, when the SSISR register is continuously read, the clearness of the transmission error flag might not be able to be read.

[Setting condition]

During transmission operation (SSICR.TEN = 1), data is written to SSIFTDR while it is full.

[Setting timing]

At completion of writing to SSIFTDR (**Figure 27.16**)

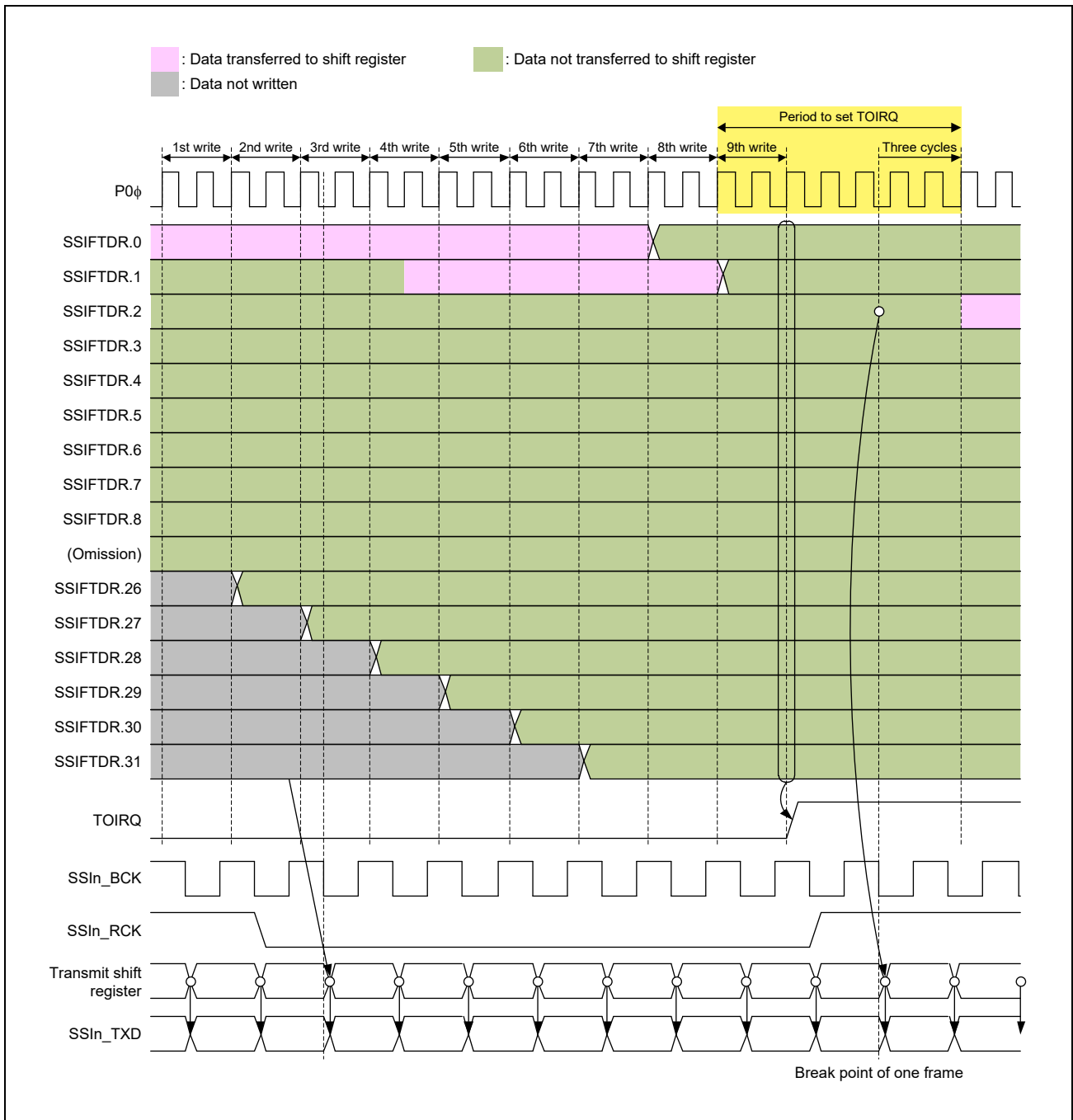

Figure 27.16 TOIRQ Setting Timing

RUIRQ Bit

This is a status flag that indicates a receive underflow error. This flag is set by automatic determination but it must be cleared by register access. This flag indicates that SSIFRDR is read while it is empty. Data read from SSIFRDR where a receive underflow error is generated is invalid. See **Section 27.5.2.6, Error Handling** for the error recovery procedure. This flag is not cleared by reception FIFO data register reset (SSIFCR.RFRST). Even if SSIFRDR is read to (SSIFCR.RFRST=1) while resetting reception FIFO data register, it doesn't set 1.

[Priority order for setting and clearing]

Setting is prioritized.*¹

[Clearing condition]

When either of the following is approved.

- (1) Writing 0 to this flag after reading this flag as 1.*²
- (2) When you do the communication permission (SSICR.REN is changed from 0 to 1)

[Clearing timing]

Timing according to the above-mentioned clear condition.

- (1) At completion of writing 0 to this flag after reading this flag as 1 (same as **Figure 27.13**).
- (2) Write 1 in SSICR.REN, complete, and after one cycle of P0φ (same as **Figure 27.13**).

Note 1. This bit is also cleared by a software reset (SSIFCR.SSIRST = 1). The software reset has priority over all the clearing conditions described above.

Note 2. The state of reading this bit as one is cleared by any of the following three conditions being met:

- Software reset (SSIFCR.SSIRST=1).
- Completion of writing 0 to this flag after having read it as 1.
- One cycle of P0φ elapsing after the completion of writing 1 to SSICR.TEN.

NOTE

After the communication is permitted (SSICR.REN is written and '1' is written from '0'), the transmission error flag (ROIRQ and RUIRQ of the SSISR register) is cleared. However, when the SSISR register is continuously read, the clearness of the reception error flag might not be able to be read.

[Setting condition]

Reading from SSIFRDR while it is empty.

[Setting timing]

At completion of reading from SSIFRDR (**Figure 27.17**).

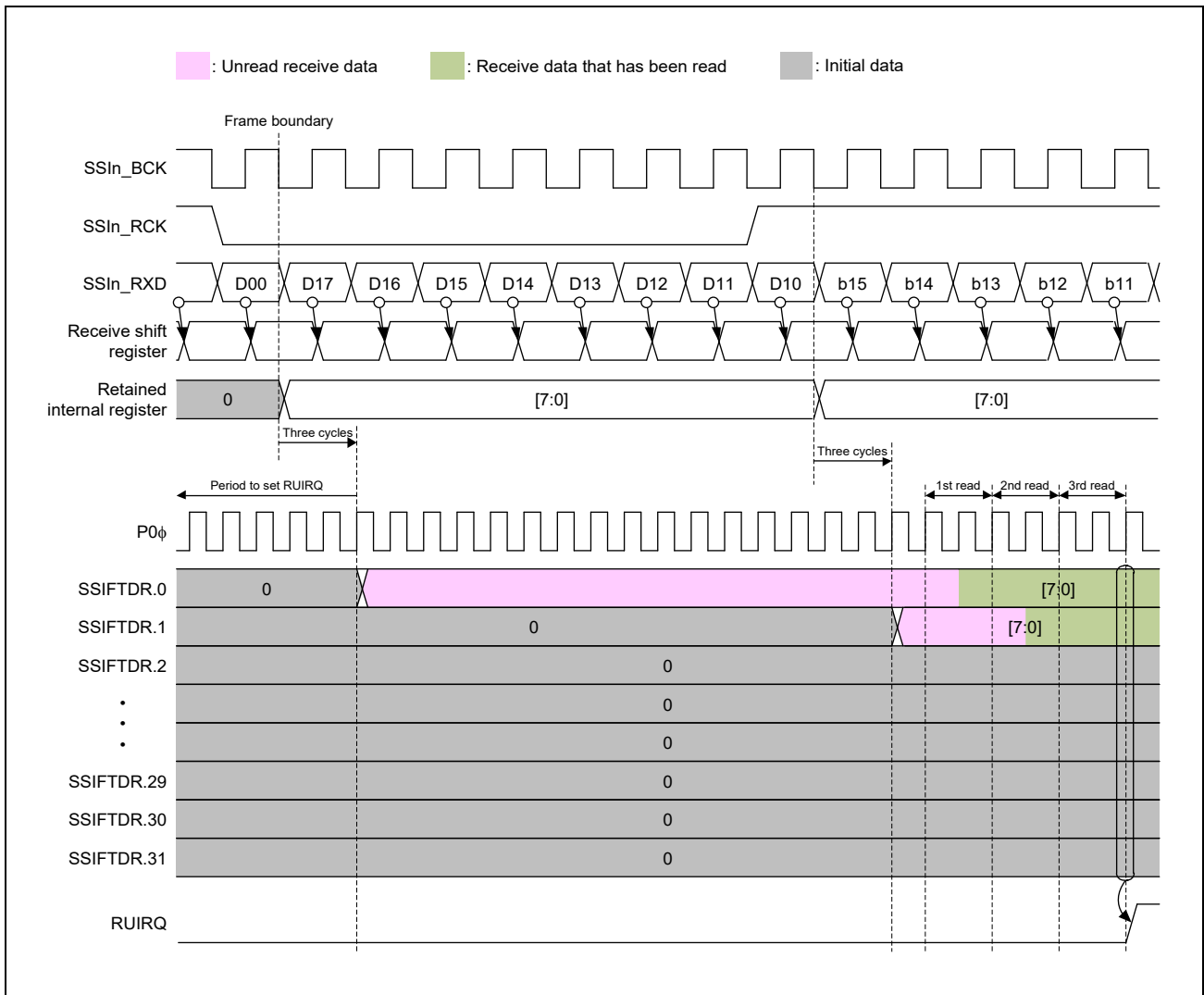

Figure 27.17 RUIRQ Setting Timing

ROIRQ Bit

This is a status flag that indicates a receive overflow error. This flag is set by automatic determination but it must be cleared by register access. This flag indicates that received data is supplied at a higher rate than requested. Data is not transferred from the receive shift register to SSIFRDR where a receive overflow error is generated. See **Section 27.5.2.6, Error Handling** for the error recovery procedure. This flag is not cleared by reception FIFO data register reset (SSIFCR.RFRST).

[Priority order for setting and clearing]

Setting is prioritized.

[Clearing condition]

Writing 0 to this flag after reading this flag as 1.

[Clearing timing]

At completion of writing 0 after reading 1 from an SFR (same as **Figure 27.13**).

[Priority order for setting and clearing]

Setting is prioritized.*¹

[Clearing condition]

When either of the following is approved.

- (1) Writing 0 to this flag after reading this flag as 1.*²
- (2) When you do the communication permission (SSICR.REN is changed from 0 to 1)

[Clearing timing]

Timing according to the above-mentioned clear condition.

- (1) At completion of writing 0 to this flag after reading this flag as 1 (same as **Figure 27.13**).
- (2) Write 1 in SSICR.REN, complete, and after one cycle of P0φ (same as **Figure 27.13**).

Note 1. This bit is also cleared by a software reset (SSIFCR.SSIRST = 1). The software reset has priority over all the clearing conditions described above.

Note 2. The state of reading this bit as one is cleared by any of the following three conditions being met:

- Software reset (SSIFCR.SSIRST=1).
- Completion of writing 0 to this flag after having read it as 1.
- One cycle of P0φ elapsing after the completion of writing 1 to SSICR.TEN.

NOTE

After the communication is permitted (SSICR.REN is written and '1' is written from '0'), the transmission error flag (ROIRQ and RUIRQ of the SSISR register) is cleared. However, when the SSISR register is continuously read, the clearness of the reception error flag might not be able to be read.

[Setting condition]

At completion of receiving new data while SSIFRDR is full.

[Setting timing]

Three cycles of P0φ after reception is completed (**Figure 27.18**).

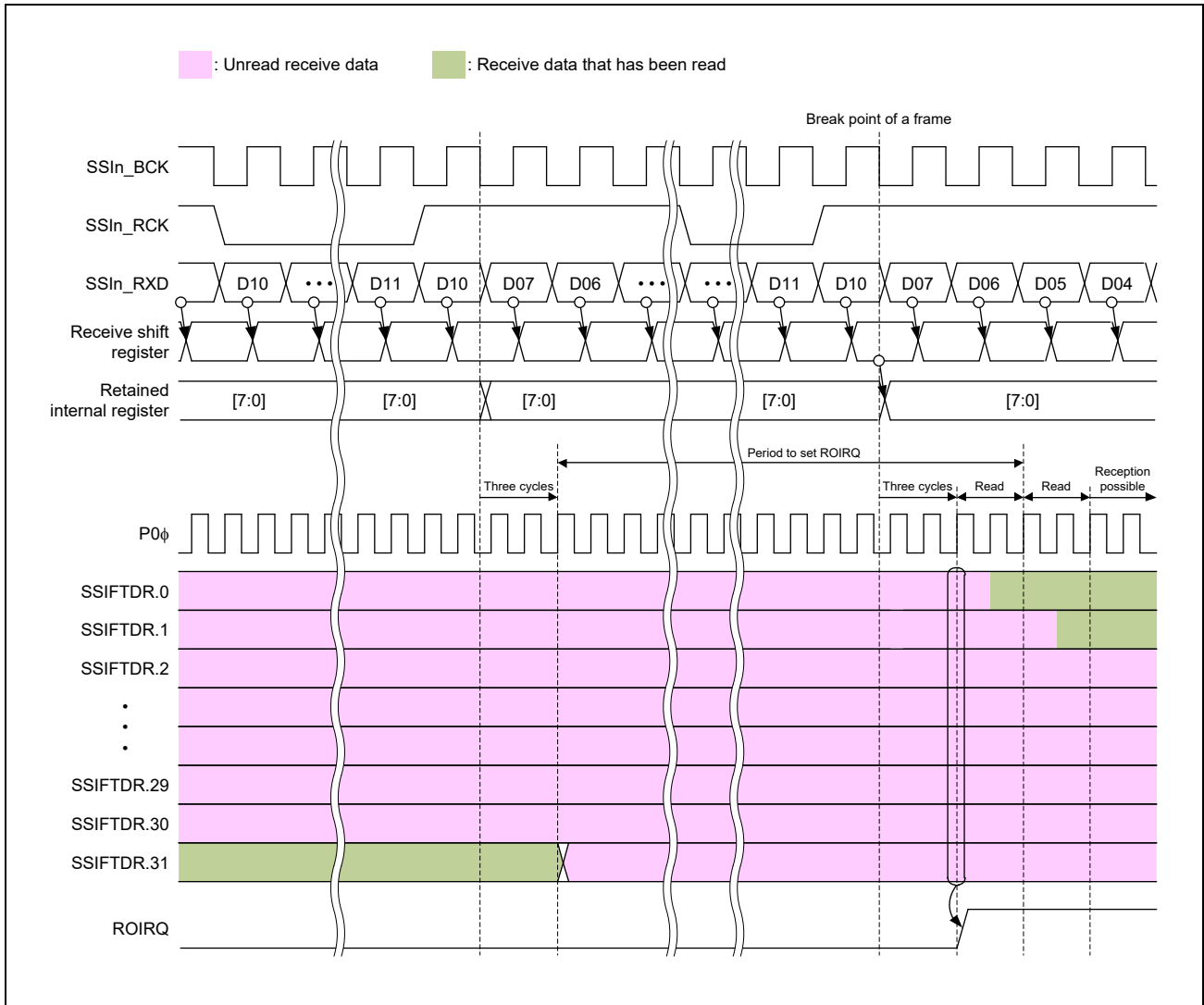

Figure 27.18 ROIRQ Setting Timing

IIRQ Bit

This is a status flag that indicates the idle state. It indicates whether SSIF-2 is in the idle state or communication state (Figure 27.19 and Figure 27.20).

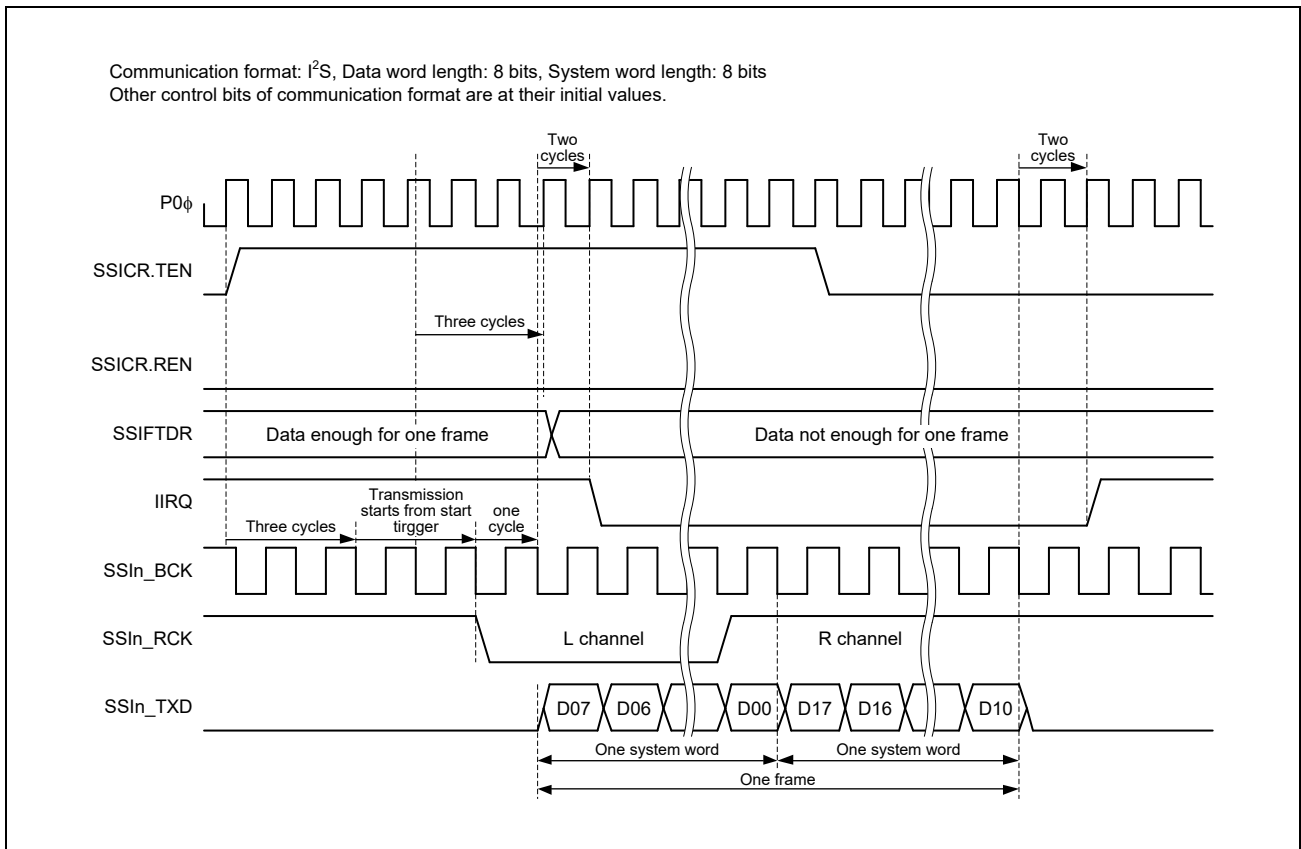

Figure 27.19 IIRQ Setting Timing (Transmission)

Transmitter (dedicated to transmission)

[Clearing condition]

While transmission is enabled (SSICR.TEN = 1 and SSICR.REN = 0), one frame of data to be transmitted has been written to SSIFTDR, and a start trigger is generated in SSILRCK/SSIFS.

[Clearing timing]

Two cycles of P0φ after one cycle of SSIBCK where a start trigger is generated.

[Setting condition]

One frame of data has been transmitted while transmission and reception are disabled (SSICR.TEN = 0 and SSICR.REN = 0).

[Setting timing]

Two cycles of P0φ after transmission is complete according to the setting condition (frame boundary).

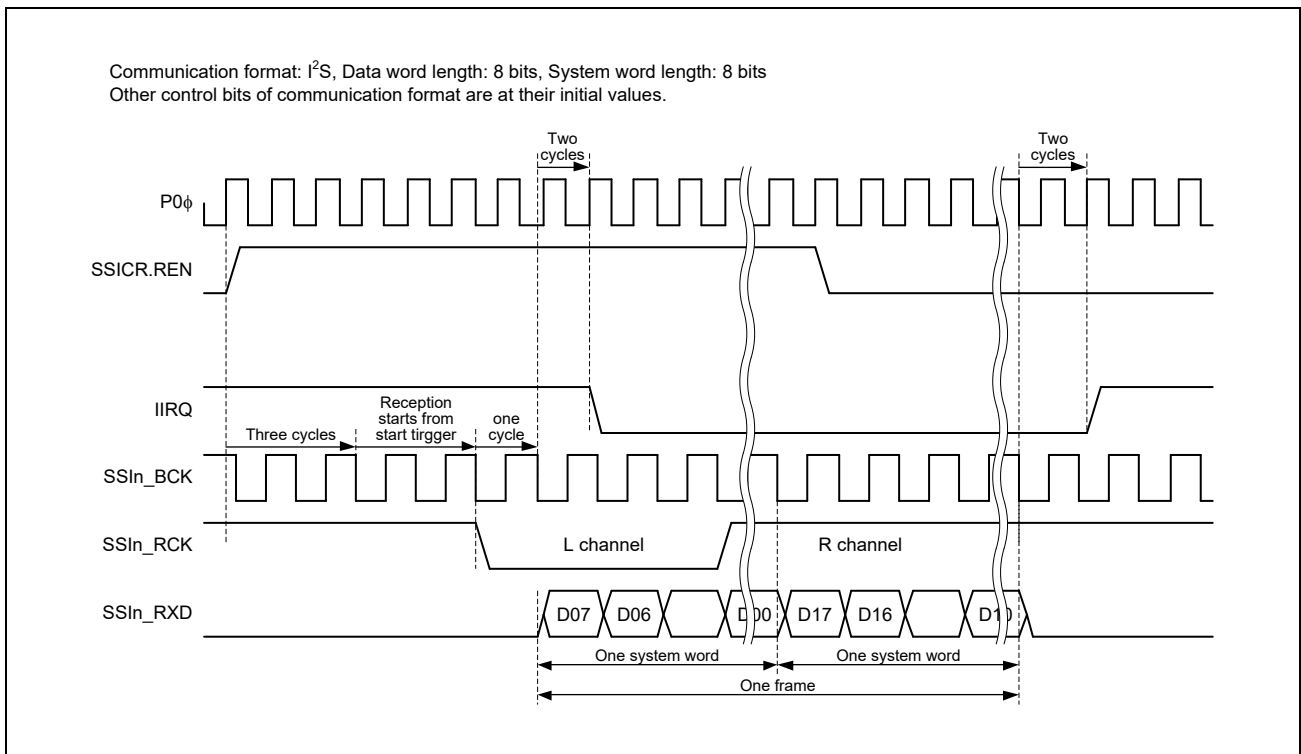

Figure 27.20 IIRQ Setting Timing (Reception)

Receiver (dedicated to reception)

[Clearing condition]

While reception is enabled (SSICR.TEN = 0 and SSICR.REN = 1), and a start trigger is generated in SSILRCK/SSIFS.

[Clearing timing]

Two cycles of P0 ϕ after one cycle of SSIBCK when a start trigger of the clearing condition is generated.

[Setting condition]

One frame of data has been received while transmission and reception are disabled (SSICR.TEN = 0 and SSICR.REN = 0).

[Setting timing]

Two cycles of P0 ϕ after reception of the setting condition is completed (frame boundary).

Transceiver (transmission and reception)

[Clearing condition]

While transmission and reception are enabled (SSICR.TEN = 1 and SSICR.REN = 1), one frame of data to be transmitted has been written to SSIFTDR, and a start trigger is generated in SSILRCK/SSIFS.

[Clearing timing]

Two cycles of P0 ϕ after one cycle of SSIBCK when a start trigger of the clearing condition is generated.

[Setting condition]

One frame of data has been transmitted while transmission and reception are disabled (SSICR.TEN = 0 and SSICR.REN = 0).

[Setting timing]

Two cycles of P0 ϕ after transmission is completed according to the setting condition (frame boundary).

27.4.1.3 FIFO Control Register (SSIFCR)

This is a readable/writable 32-bit register. It sets a software reset, byte swap, noise canceller, and enable/disable of interrupt requests.

Bit	31	30	29	28	27	26	25	24	23	22	21	20	19	18	17	16
	AUCKE	—	—	—	—	—	—	—	—	—	—	—	—	—	—	SSIRST
Initial Value	0	0	0	0	0	0	0	0	0	0	0	0	0	0	0	0
R/W	R/W	R	R	R	R	R	R	R	R	R	R	R	R	R	R	R/W
Bit	15	14	13	12	11	10	9	8	7	6	5	4	3	2	1	0
	—	—	—	—	BSW	BCKNCE	LRCKNCE	RXDNCE	—	—	—	—	TIE	RIE	TFRST	RFRST
Initial Value	0	0	0	0	0	0	0	0	0	0	0	0	0	0	0	0
R/W	R	R	R	R	R/W	R/W	R/W	R/W	R	R	R	R	R/W	R/W	R/W	R/W

Bit	Bit Name	Initial Value	R/W	Description
31	AUCKE	0	RW	AUDIO_MCK Enable in Master-mode Communication*1 0: Disables supply of AUDIO_MCK 1: Enables supply of AUDIO_MCK
30 to 17	—	H'0000	R	Reserved. Write 0. The read value is 0.
16	SSIRST	0	RW	Software Reset 0: Clears a software reset condition 1: Sets a software reset condition
15 to 12	—	H'00	R	Reserved. Write 0. The read value is 0.
11	BSW	0	RW	Byte Swap Enable*1 0: Disables byte swap 1: Enables byte swap
10	BCKNCE	0	RW	Noise Canceller Enable in Slave-mode Communication (SSIBCK)*1,*2 0: Disables (bypasses) the noise canceller 1: Enables the noise canceller
9	LRCKNCE	0	RW	Noise Canceller Enable in Slave-mode Communication (SSILRCK/ SSIFS)*1,*2 0: Disables (bypasses) the noise canceller 1: Enables the noise canceller
8	RXDNCE	0	RW	Received Data Input Noise Canceller Enable in Slave-mode Communication (SSIRxD)*1,*2 0: Disables (bypasses) the noise canceller 1: Enables the noise canceller
7 to 4	—	H'00	R	Reserved. Write 0. The read value is 0.
3	TIE	0	RW	Transmit Data Empty Interrupt Output Enable 0: Disables transmit data empty interrupts 1: Enables transmit data empty interrupts
2	RIE	0	RW	Receive Data Full Interrupt Output Enable 0: Disables receive data full interrupts 1: Enables receive data full interrupts
1	TFRST	0	RW	Transmit FIFO data register reset*1 0: Clears a transmit data FIFO reset condition 1: Sets a transmit data FIFO reset condition
0	RFRST	0	RW	Receive FIFO data register reset*1 0: Clears a receive data FIFO reset condition 1: Sets a receive data FIFO reset condition

- Note 1. Writing to these bits while SSIF-2 is in a communication state (SSISR.IIRQ = 0) is prohibited. If written, the operation performed immediately after writing is not guaranteed.
- Note 2. This bit can only be set to 1 in slave-mode communication (SSICR.MST = '0') except in the case of transmission (SSICR.TEN = '1') while SSICR.DEL = '1'. Be sure to clear this bit to 0 in master-mode communication (SSICR.MST = '1') or during transmission in slave mode (SSICR.MST = '0', SSICR.TEN = '1') while SSICR.DEL = '1'. Set the BCKNCE, LRCKNCE, and RXDNCE bits to the same value.

AUCKE Bit

This bit enables/disables supply to AUDIO_MCK while in master-mode communication (MST = 1). Select AUDIO_MCK (SSICR.CKS bit) before writing 1 to this bit.

Rewrite this bit after completing the setting (CKS, MST, BCKP, and CKDV of the SSICR register) that relates to AUDIO_MCK.

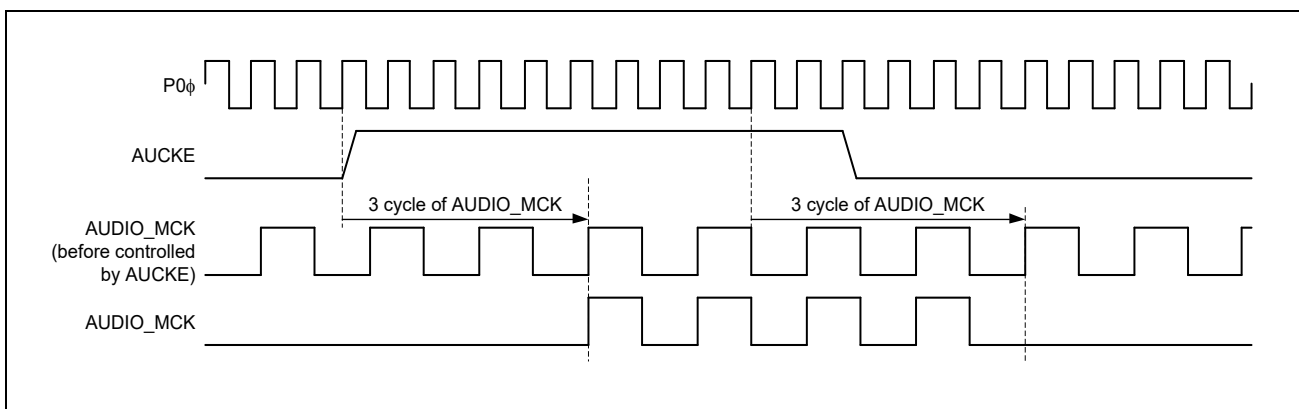

Figure 27.21 Stop/Resume of AUDIO_MCK

CAUTION

- In slave-mode communication (SSICR.MST = 0), SSIF-2 needs supply of SSIBCK. To stop BCK on the master side, make sure that SSIF-2 is in the idle state (SSISR.IIRQ = 1). If BCK is stopped before SSIF-2 becomes idle, take the procedure to start communication (**Figure 27.52**) or wait for an idle state by taking the procedure to resume communication (**Figure 27.57**).
- In master-mode communication (SSICR.MST = 1), SSIF-2 operates with the audio clock (AUDIO_MCK). To stop SSIF-2 completely, make sure that SSIF-2 is in the idle state (SSISR.IIRQ = 1) and then write 0 to SSIFCR.ADCKE. If 0 is written to SSIFCR.ADCKE before SSIF-2 becomes idle, take the procedure to start communication (**Figure 27.52**) or wait for the idle state by taking the procedure to resume communication (**Figure 27.57**).

Figure 27.22 and Figure 27.23 show timing until outputting it to the terminal SSIBCK after this bit is set to '1'.

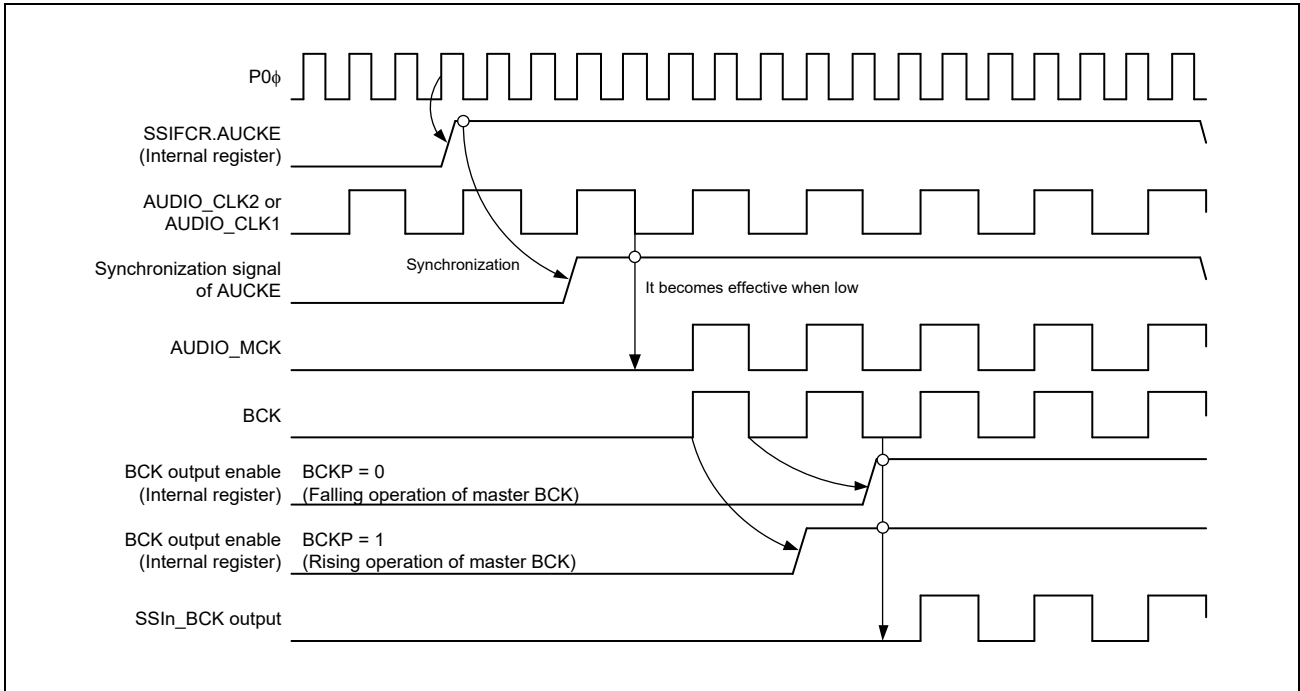

Figure 27.22 Timing chart when it begins to communicate master from system reset

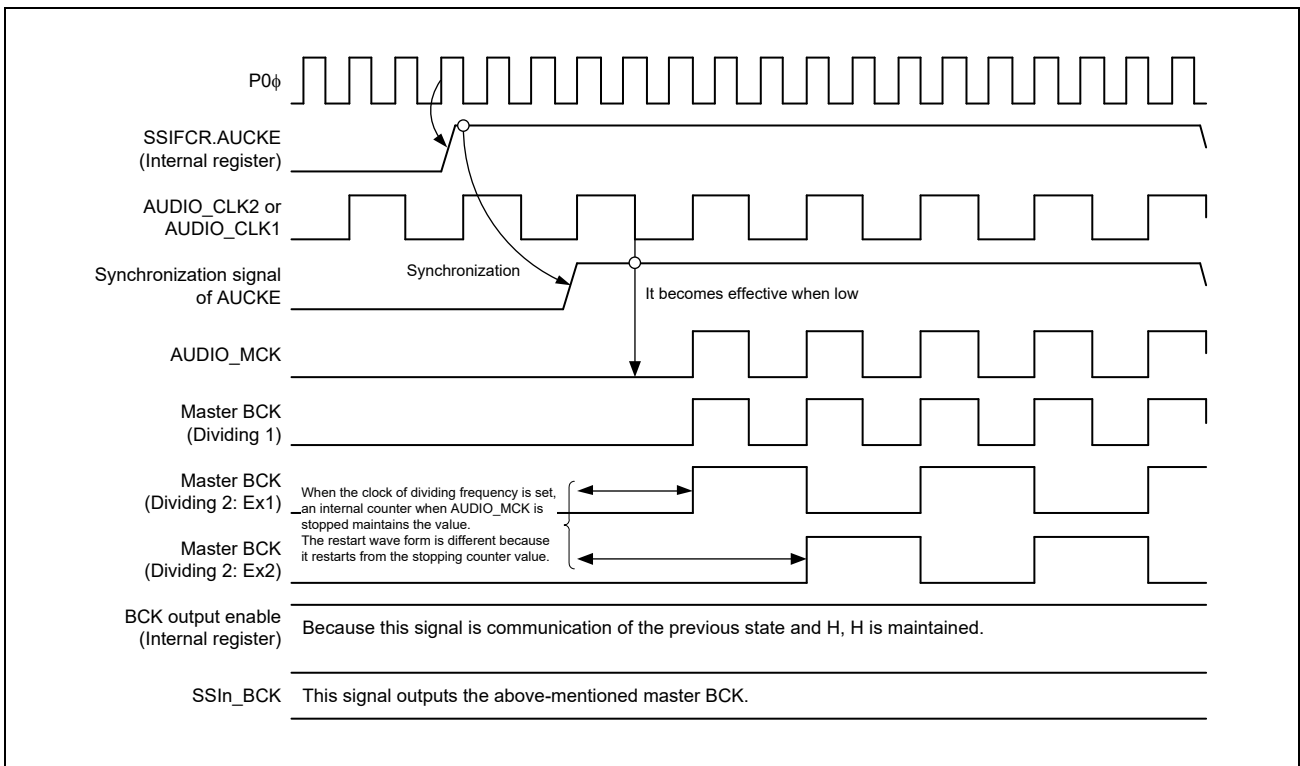

Figure 27.23 Timing chart when it begins to communicate master from communication stop

NOTE

When the supply of AUDIO_MCK is stopped, the terminal SSIBCK maintains the value. The terminal SSIBCK might stop in the state of "H".

SSIRST Bit

This bit sets a software reset of SSIF-2. Writing 1 to this bit initializes the internal state of SSIF-2. After a reset by writing 1, write 0 to release the reset because this bit is not automatically cleared to 0. After writing 0 to this bit, make sure that the bit becomes 0 before the next procedure.

To stop communication of SSIF-2 immediately, after turning off the peripheral functions, write 1 to this bit. Initialization by a software reset is performed without any relation with the bit clock.

Table 27.7 Bits Initialized by Software Reset of the SSIFCR.SSIRST Bit

Symbol	Address (Base+)		+0								+1							
			31	30	29	28	27	26	25	24	23	22	21	20	19	18	17	16
			15	14	13	12	11	10	9	8	7	6	5	4	3	2	1	0
SSICR	H'00	+0	—	CKS	TUIEN	TOIEN	RUIEN	ROIEN	IEN	—	FRM[1:0]		DWL[2:0]			SWL[2:0]		
		+2	—	MST	BCKP	LRCKP	SPDP	SDTA	PDTA	DEL	CKDV[3:0]			MUEN	—	TEN	REN	
SSISR	H'04	+0	—	—	TUIRQ	TOIRQ	RUIRQ	ROIRQ	IIRQ	—	—	—	—	—	—	—	—	
		+2	—	—	—	—	—	—	—	—	—	—	—	—	—	—	—	
SSIFCR	H'10	+0	AUCKE	—	—	—	—	—	—	—	—	—	—	—	—	—	SSIRST	
		+2	—	—	—	—	BSW	BCKN CE	LRCKN CE	RxDN E	—	—	—	—	TIE	RIE	TFRST	RFRST
SSIFSR	H'14	+0	—	—	TDC[5:0]					—	—	—	—	—	—	—	TDE	
		+2	—	—	RDC[5:0]					—	—	—	—	—	—	—	RDF	
SSIFTDR	H'18	+0	FTDR[31:16]															
		+2	FTDR[15:0]															
SSIFRDR	H'1C	+0	FRDR[31:16]															
		+2	FRDR[15:0]															
SSIOFR	H'20	+0	—	—	—	—	—	—	—	—	—	—	—	—	—	—	—	
		+2	—	—	—	—	—	—	BCKAS TP	LRCON T	—	—	—	—	—	—	OMOD[1:0]	
SSISCR	H'24	+0	—	—	—	—	—	—	—	—	—	—	—	—	—	—	—	
		+2	—	—	—	TDES[4:0]					—	—	—	RDFS[4:0]				

BSW Bit

This bit enables/disables byte swap of register access for the transmit FIFO data register (SSIFTDR) and the receive FIFO data register (SSIFRDR). This bit is valid only with 16-bit access or 32-bit access to SSIFTDR and SSIFRDR (**Figure 27.24**).

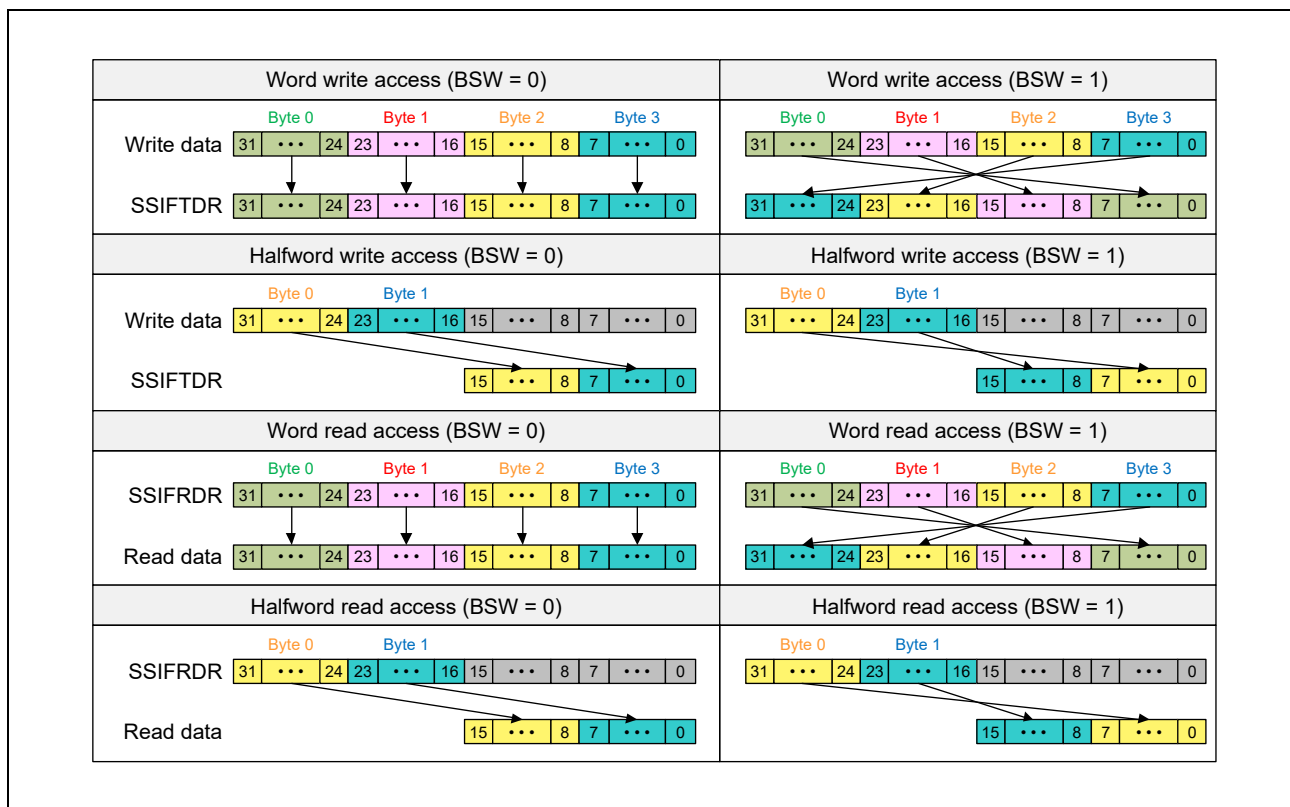

Figure 27.24 Operation Example of Byte Swap

BCKNCE Bit

This bit enables or disables the noise cancellation function supporting the suppression of transients 15-ns in length (typ.) in input signals on the SSIBCK pin in slave-mode communication (SSICR.MST = '0') except in the case of transmission (SSICR.TEN = '1') while SSICR.DEL = '1'. The setting of this bit in master-mode communication (SSICR.MST = '1') is disabled.

Be sure to clear this bit to 0 in master-mode communication or during transmission in slave mode (SSICR.MST = '0', SSICR.TEN = '1') while SSICR.DEL = '1'. Set the BCKNCE, LRCKNCE, and RXDNCE bits to the same value.

LRCKNCE Bit

This bit enables or disables the noise cancellation function supporting the suppression of transients 15-ns in length (typ.) in input signals on the SSILRCK and SSIFS pins in slave-mode communication (SSICR.MST = '0') except in the case of transmission (SSICR.TEN = '1') while SSICR.DEL = '1'. The setting of this bit in master-mode communication (SSICR.MST = '1') is disabled.

Be sure to clear this bit to 0 in master-mode communication or during transmission in slave mode (SSICR.MST = '0', SSICR.TEN = '1') while SSICR.DEL = '1'. Set the BCKNCE, LRCKNCE, and RXDNCE bits to the same value.

RXDNCE Bit

This bit enables or disables the noise cancellation function supporting the suppression of transients 15-ns in length (typ.) in input signals on the SSIRxD pin in slave-mode communication (SSICR.MST = '0') except in the case of transmission (SSICR.TEN = '1') while SSICR.DEL = '1' and while reception is enabled (SSICR.REN = '1').

The setting of this bit in master-mode communication (SSICR.MST = '1') or while reception is disabled (SSICR.REN = '0') is disabled.

Be sure to clear this bit to 0 in master-mode communication or during transmission in slave mode (SSICR.MST = '0', SSICR.TEN = '1') while SSICR.DEL = '1'. Set the BCKNCE, LRCKNCE, and RXDNCE bits to the same value.

TIE Bit

This bit enables/disables output of transmit data empty interrupts. Transmission data empty interrupt is used as an interrupt factor written in the FIFO transmission data register. Set this bit to 1 after setting set condition (SSISCR.TDES) of transmission data empty interrupt. See **Figure 27.25** for the generation timing of a transmit data empty interrupt.

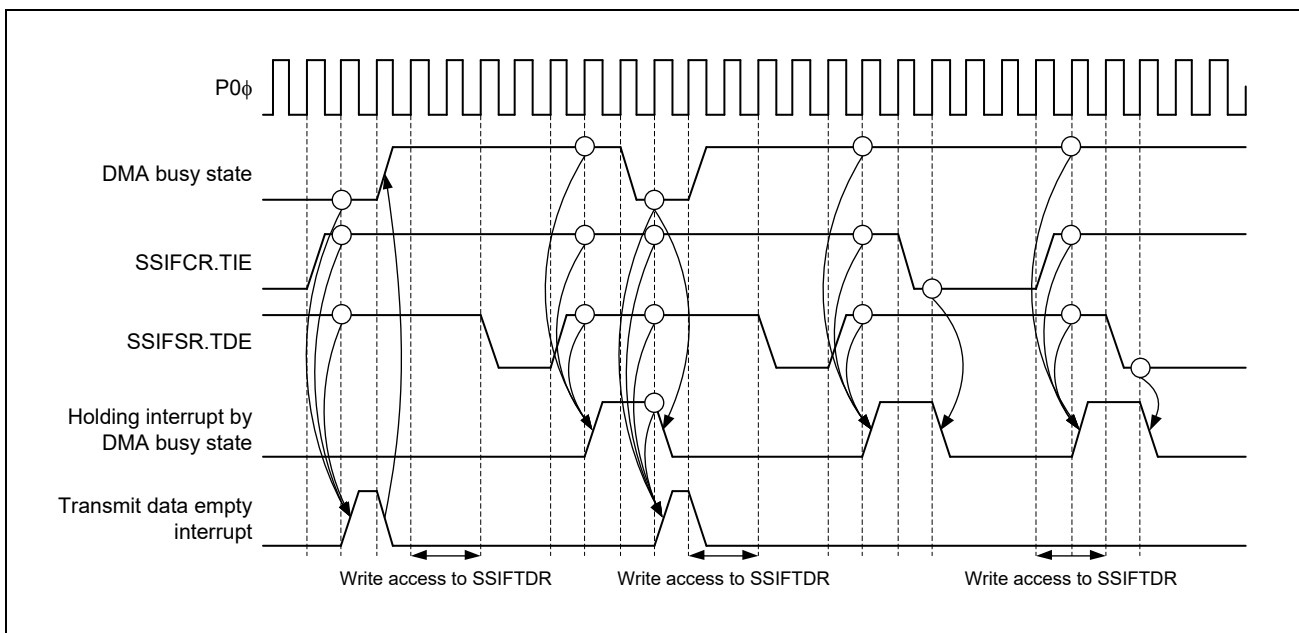

Figure 27.25 Generation timing of transmit data empty interrupt

RIE Bit

This bit enables/disables output of receive data full interrupts. Receive data empty interrupt is used as an interrupt factor to read the FIFO receive data register. Set this bit to 1 after setting set condition (SSISCR.RDFS) of Receive data empty interrupt. See **Figure 27.26** for the generation timing of a receive data full interrupt.

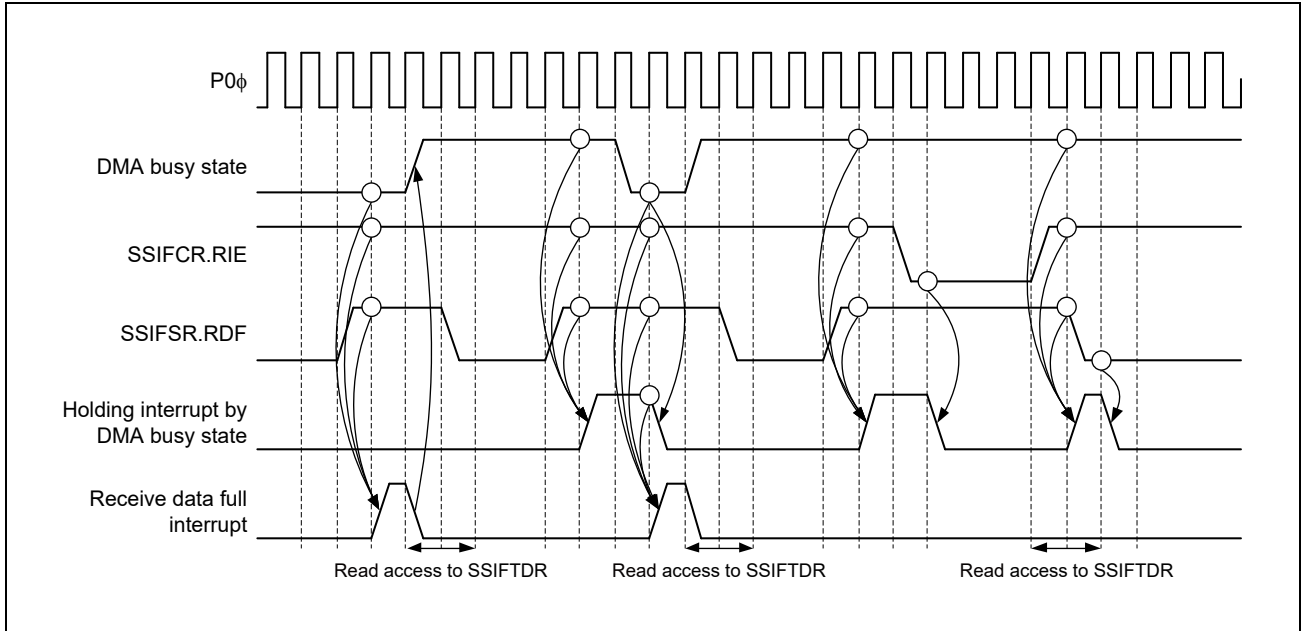

Figure 27.26 Generation timing of receive data empty interrupt

TFRST Bit

This bit sets a software reset of the transmit FIFO data register (SSIFTDR). Writing 1 to this bit initializes the internal state related to SSIFTDR. See **Table 27.8** for the registers to which this software reset is applied. After a reset by writing 1, write 0 to clear the reset condition because this bit is not automatically cleared to 0. After writing 0 to this bit, make sure that the bit becomes 0 before the next procedure.

This bit is a bit of SSIRST for reset. Software reset by SSIRST becomes and writing this bit becomes invalid because of priority.

Table 27.8 Bits Initialized by Software Reset of the SSIFCR.TFRST Bit

Symbol	Address (Base+)		+0								+1							
			31	30	29	28	27	26	25	24	23	22	21	20	19	18	17	16
			15	14	13	12	11	10	9	8	7	6	5	4	3	2	1	0
SSICR	H'00	+0	—	CKS	TUIEN	TOIEN	RUIEN	ROIEN	IEN	—	FRM[1:0]	DWL[2:0]			SWL[2:0]			
		+2	—	MST	BCKP	LRCKP	SPDP	SDTA	PDTA	DEL	CKDV[3:0]			MUEN	—	TEN	REN	
SSISR	H'04	+0	—	—	TUIRQ	TOIRQ	RUIRQ	ROIRQ	IIRQ	—	—	—	—	—	—	—	—	
		+2	—	—	—	—	—	—	—	—	—	—	—	—	—	—	—	
SSIFCR	H'10	+0	AUCKE	—	—	—	—	—	—	—	—	—	—	—	—	—	SSIRST	
		+2	—	—	—	—	BSW	BCKN CE	LRCKN CE	RxDN E	—	—	—	—	TIE	RIE	TFRST	RFRST
SSIFSR	H'14	+0	—	—	TDC[5:0]					—	—	—	—	—	—	—	TDE	
		+2	—	—	RDC[5:0]					—	—	—	—	—	—	—	RDF	
SSIFTDR	H'18	+0	FTDR[31:16]															
		+2	FTDR[15:0]															
SSIFRDR	H'1C	+0	FRDR[31:16]															
		+2	FRDR[15:0]															
SSIOFR	H'20	+0	—	—	—	—	—	—	—	—	—	—	—	—	—	—	—	
		+2	—	—	—	—	—	—	BCKAS TP	LRCO NT	—	—	—	—	—	—	OMOD[1:0]	
SSISCR	H'24	+0	—	—	—	—	—	—	—	—	—	—	—	—	—	—	—	
		+2	—	—	—	TDES[4:0]					—	—	—	RDFS[4:0]				

RFRST Bit

This bit sets a software reset of the receive FIFO data register (SSIFRDR). Writing 1 to this bit initializes the internal state related to SSIFRDR. After a reset by writing 1, write 0 to clear the reset condition because this bit is not automatically cleared to 0. After writing 0 to this bit, make sure that the bit becomes 0 before the next procedure.

This bit is a bit of SSIRST for reset. Software reset by SSIRST becomes and writing this bit becomes invalid because of priority.

Table 27.9 Bits Initialized by Software Reset of the SSIFCR.TFRST Bit

Symbol	Address (Base+)		+0								+1							
			31	30	29	28	27	26	25	24	23	22	21	20	19	18	17	16
			15	14	13	12	11	10	9	8	7	6	5	4	3	2	1	0
SSICR	H'00	+0	—	CKS	TUIEN	TOIEN	RUIEN	ROIEN	IIEN	—	FRM[1:0]		DWL[2:0]			SWL[2:0]		
		+2	—	MST	BCKP	LRCKP	SPDP	SDTA	PDTA	DEL	CKDV[3:0]			MUEN	—	TEN	REN	
SSISR	H'04	+0	—	—	TUIRQ	TOIRQ	RUIRQ	ROIIRQ	IIRQ	—	—	—	—	—	—	—	—	
		+2	—	—	—	—	—	—	—	—	—	—	—	—	—	—	—	
SSIFCR	H'10	+0	AUCKE	—	—	—	—	—	—	—	—	—	—	—	—	—	SSIRST	
		+2	—	—	—	—	BSW	BCKNCE	LRCKNCE	RxDNCE	—	—	—	—	TIE	RIE	TFRST	RFRST
SSIFSR	H'14	+0	—	—	TDC[5:0]					—	—	—	—	—	—	—	TDE	
		+2	—	—	RDC[5:0]					—	—	—	—	—	—	—	RDF	
SSIFTDR	H'18	+0	FTDR[31:16]															
		+2	FTDR[15:0]															
SSIFRDR	H'1C	+0	FRDR[31:16]															
		+2	FRDR[15:0]															
SSIOFR	H'20	+0	—	—	—	—	—	—	—	—	—	—	—	—	—	—	—	
		+2	—	—	—	—	—	—	BCKA STP	LRCON T	—	—	—	—	—	—	OMOD[1:0]	
SSISCR	H'24	+0	—	—	—	—	—	—	—	—	—	—	—	—	—	—	—	
		+2	—	—	—	TDES[4:0]					—	—	—	RDFS[4:0]				

27.4.1.4 FIFO Status Register (SSIFSR)

This register is configured with status flags that indicate the status of the transmit FIFO data register and the receive FIFO data register.

Bit	31	30	29	28	27	26	25	24	23	22	21	20	19	18	17	16	
	—	—	TDC[5:0]					—	—	—	—	—	—	—	—	—	TDE
Initial Value	0	0	0	0	0	0	0	0	0	0	0	0	0	0	0	0	1
R/W	R	R	R	R	R	R	R	R	R	R	R	R	R	R	R	R	R/W0
Bit	15	14	13	12	11	10	9	8	7	6	5	4	3	2	1	0	
	—	—	RDC[5:0]					—	—	—	—	—	—	—	—	—	RDF
Initial Value	0	0	0	0	0	0	0	0	0	0	0	0	0	0	0	0	0
R/W	R	R	R	R	R	R	R	R	R	R	R	R	R	R	R	R	R/W0

Bit	Bit Name	Initial Value	R/W	Description
31, 30	—	H'0	R	Reserved. Write 0. The read value is 0.
29 to 24	TDC[5:0]	H'00	R	Number of Transmit FIFO Data Indication Flag
23 to 17	—	H'00	R	Reserved. Write 0. The read value is 0.
16	TDE	1	RW0	Transmit Data Empty Flag 0: The free space of SSIFTDR is not more than the value of SSISCR.TDES 1: The free space of SSIFTDR is not less than the value of SSISCR.TDES plus one.
15, 14	—	H'0	R	Reserved. Write 0. The read value is 0.
13 to 8	RDC[5:0]	H'00	R	Number of Receive FIFO Data Indication Flag
7 to 1	—	H'00	R	Reserved. Write 0. The read value is 0.
0	RDF	0	RW0	Receive Data Full Flag 0: The size of received data in SSIFRDR is not more than the value of SSISCR.RDFS 1: The size of received data in SSIFRDR is not less than the value of SSISCR.RDFS plus one.

TDC[5:0] Bits

These bits indicate the number of valid data that are stored in the transmit FIFO data register (SSIFTDR). With this flag as H'0, there is no data to be transmitted. With H'20, there is no space to write data.

TDE Bit

This bit indicates that the transmit FIFO data register (SSIFTDR) has free space not less than the amount set with the SSISCR.TDES bit plus one. This flag is set by automatic determination but it must be cleared by register access.

[Priority order for setting and clearing]

Clearing is prioritized.*¹

[Clearing condition]

Either of the following two:

- (1) Writing 0 to this bit after reading this bit as 1.*²
- (2) When writing data to SSIFTDR.

[Clearing timing]

Timing according to the above-mentioned clear condition.

- (1) At completion of writing 0 to this bit after reading this bit as 1 (**Figure 27.13**).
- (2) When writing data to SSIFTDR.

Note 1. This bit is also cleared by a software reset (SSIFCR.SSIRST = 1) and transmit FIFO data register reset (SSIFCR.TFRST = 1). The software reset and transmit FIFO data register reset have priority over all the clearing conditions described above.

Note 2. The state of reading this bit as one is cleared by any of the following four conditions being met:

- Software reset (SSIFCR.SSIRST = 1)
- Resetting of the transmit FIFO data register (SSIFCR.TFRST = 1)
- Completion of writing 0 to this flag after having read it as 1.
- When writing data to SSIFTDR.

[Setting condition]

SSIFTDR has free space not less than the amount set with the SSISCR.TDES bit plus one.

[Setting timing]

While operating on P0φ, SSIFTDR is found to have free space not less than “size set in the SSISCR.TDES bits + 1.”

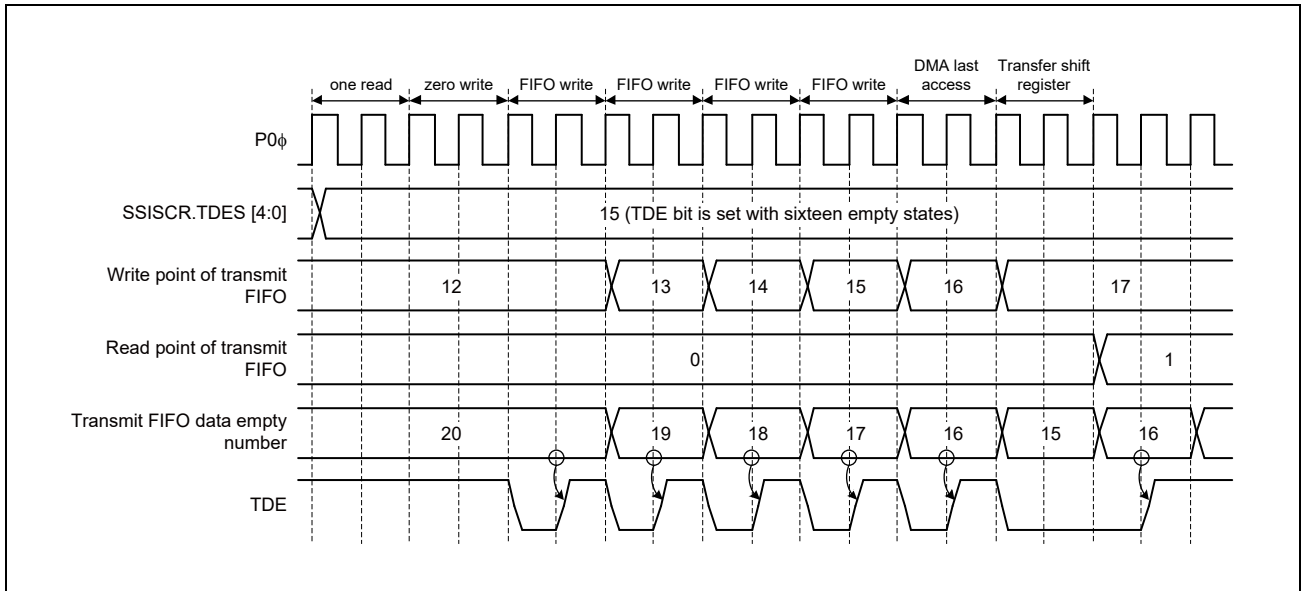

Figure 27.27 Set timing and clear timing of TDE

RDC[5:0] Bits

These bits indicate the number of valid data that are stored in the receive FIFO data register (SSIFRDR). With this flag as H'0, there is no received data. With H'20, the register is filled with received data and there is no free space.

RDF Bit

This bit indicates that the receive FIFO data register (SSIFRDR) has unread received data not less than the amount set with the SSISCR.RDFS bit plus one. This flag is set by automatic determination but it must be cleared by register access.

[Priority order for setting and clearing]

Clearing is prioritized.*1

[Clearing condition]

Either of the following two:

- (1) Writing 0 to this bit after reading this bit as 1.*2
- (2) When reading data from SSIFRDR.

[Clearing timing]

Timing according to the above-mentioned clear condition.

- (1) At completion of writing 0 to this bit after reading this bit as 1 (**Figure 27.13**).
- (2) After reading data from SSIFRDR.

Note 1. This bit is also cleared by a software reset (SSIFCR.SSIRST = 1) and receive FIFO data register reset (SSIFCR.RFRST = 1). Clearing conditions available for these bits are the software reset and receive FIFO data register reset as well as the clearing conditions described above.

Note 2. The state of reading this bit as one is cleared by any of the following four conditions being met:

- Software reset (SSIFCR.SSIRST = 1)
- Receive FIFO data register reset (SSIFCR.RFRST = 1)
- Completion of writing 0 to this flag after having read it as 1.
- When reading data from SSIFRDR.

[Setting condition]

SSIFRDR has data not less than the amount set with the SSISCR.RDFS bit plus one.

[Setting timing]

At completion of transfer from the shift register that results in SSIFRDR having data not less than the amount set with the SSISCR.RDFS bit plus one.

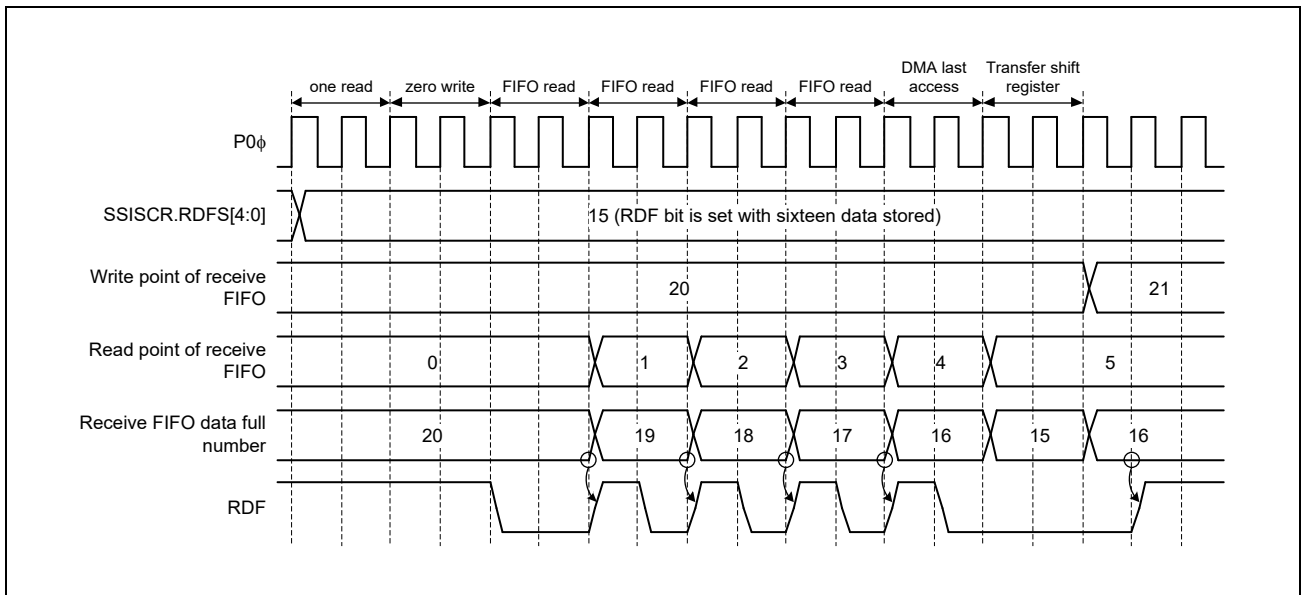

Figure 27.28 Set timing and clear timing of RDF

27.4.1.5 Transmit FIFO Data Register (SSIFTDR)

This is a 32-bit writable register. 0 is returned when this register is read. This register stores data to be serially transmitted.

Bit	31	30	29	28	27	26	25	24	23	22	21	20	19	18	17	16
	SSIFTDR[31:16]															
Initial Value	0	0	0	0	0	0	0	0	0	0	0	0	0	0	0	0
R/W	W	W	W	W	W	W	W	W	W	W	W	W	W	W	W	W
Bit	15	14	13	12	11	10	9	8	7	6	5	4	3	2	1	0
	SSIFTDR[15:0]															
Initial Value	0	0	0	0	0	0	0	0	0	0	0	0	0	0	0	0
R/W	W	W	W	W	W	W	W	W	W	W	W	W	W	W	W	W

Bit	Bit Name	Initial Value	R/W	Description
31 to 0	SSIFTDR[31:0]	H'00000000	W	Transmit FIFO data

To use this register for transmission, set DMA operation handling of a transmit data empty interrupt as writing to this register. Determine the access size to this register according to the data word length to be communicated (**Table 27.10**).

Table 27.10 Register Access Restriction to FIFOs

Access Size				
SSICR.DWL[2:0]	Data Word Length	Byte	Halfword	Word
000b	8	✓	—	—
001b	16	—	✓	—
010b	18	—	—	✓
011b	20	—	—	✓
100b	22	—	—	✓
101b	24	—	—	✓
110b	32	—	—	✓
111b	Setting prohibited	—	—	—

Figure 27.29 shows register access to the transmit FIFO data register.

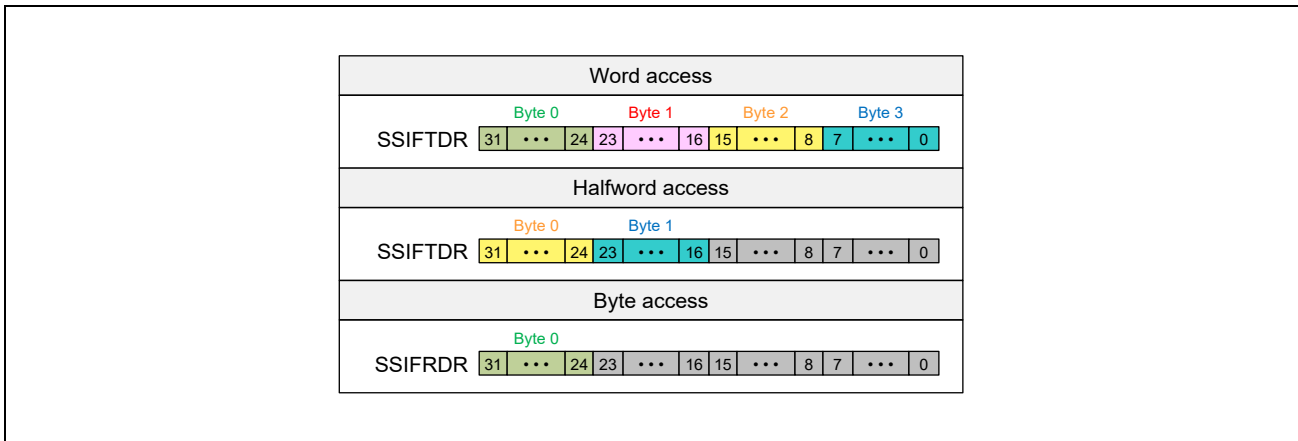

Figure 27.29 Example of Register Access to the Transmit FIFO Data Register

Figure 27.30 shows the configurations and operation examples of the transmit FIFO data register and transmit shift register. The configurations are for storing data to FIFO and not related with communication.

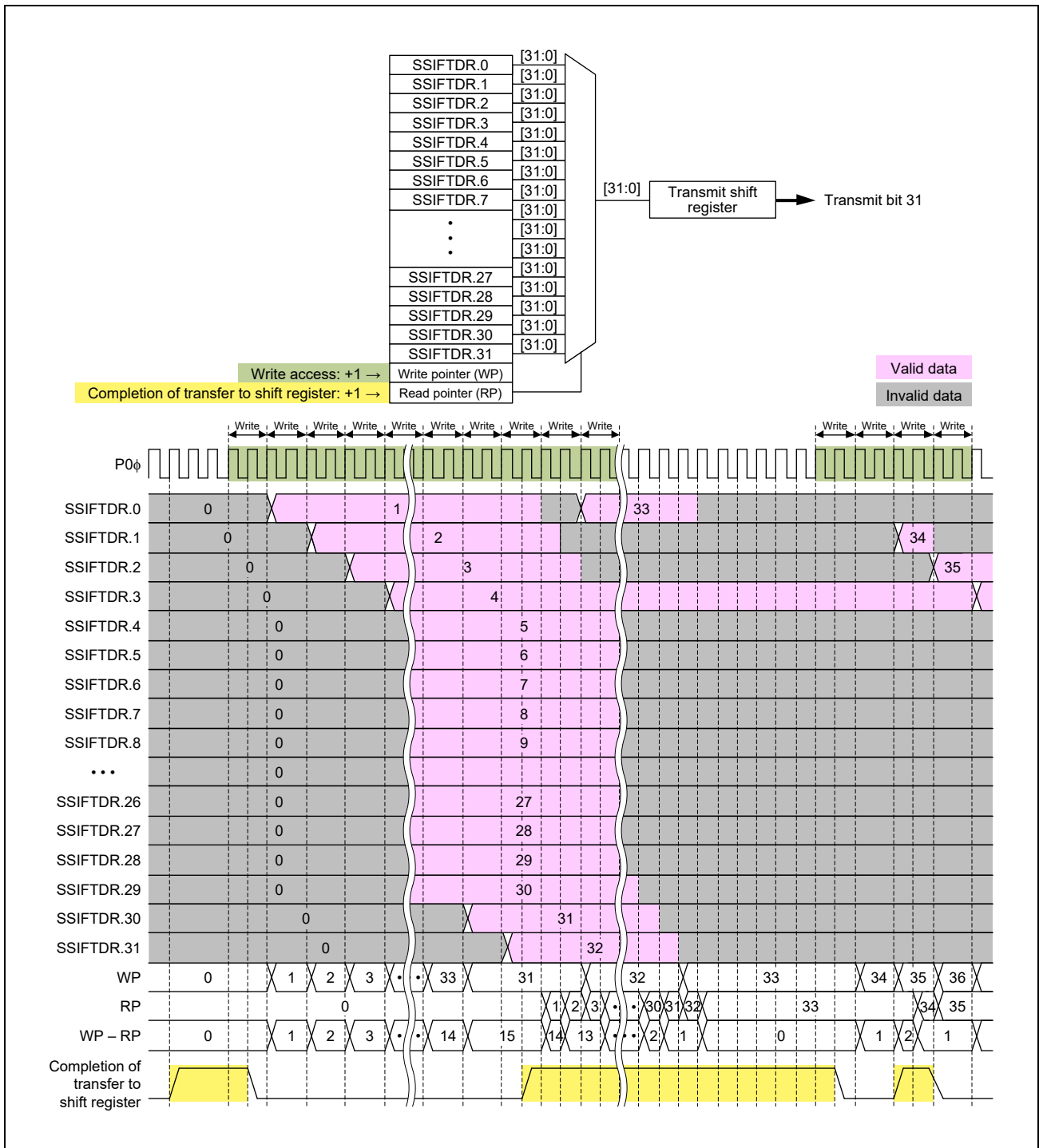

Figure 27.30 Configuration of the Transmit FIFO Data Register and Transmit Shift Register, and FIFO Operation Example

27.4.1.6 Receive FIFO Data Register (SSIFRDR)

This is a readable 32-bit register. This register stores received serial data.

Bit	31	30	29	28	27	26	25	24	23	22	21	20	19	18	17	16
	SSIFRDR[31:16]															
Initial Value	0	0	0	0	0	0	0	0	0	0	0	0	0	0	0	0
R/W	R	R	R	R	R	R	R	R	R	R	R	R	R	R	R	R
Bit	15	14	13	12	11	10	9	8	7	6	5	4	3	2	1	0
	SSIFRDR[15:0]															
Initial Value	0	0	0	0	0	0	0	0	0	0	0	0	0	0	0	0
R/W	R	R	R	R	R	R	R	R	R	R	R	R	R	R	R	R

Bit	Bit Name	Initial Value	R/W	Description
31 to 0	SSIFRDR[31:0]	H'00000000	R	Receive FIFO data

To use this register for reception, set DMA operation handling of a receive data full interrupt as reading from this register. Determine the access size to this register according to the data word length to be communicated (**Table 27.10**). Register access to the receive FIFO data register is same as for the transmit FIFO data register (**Figure 27.29**).

Figure 27.31 shows the configurations and operation examples of the receive FIFO data register and receive shift register.

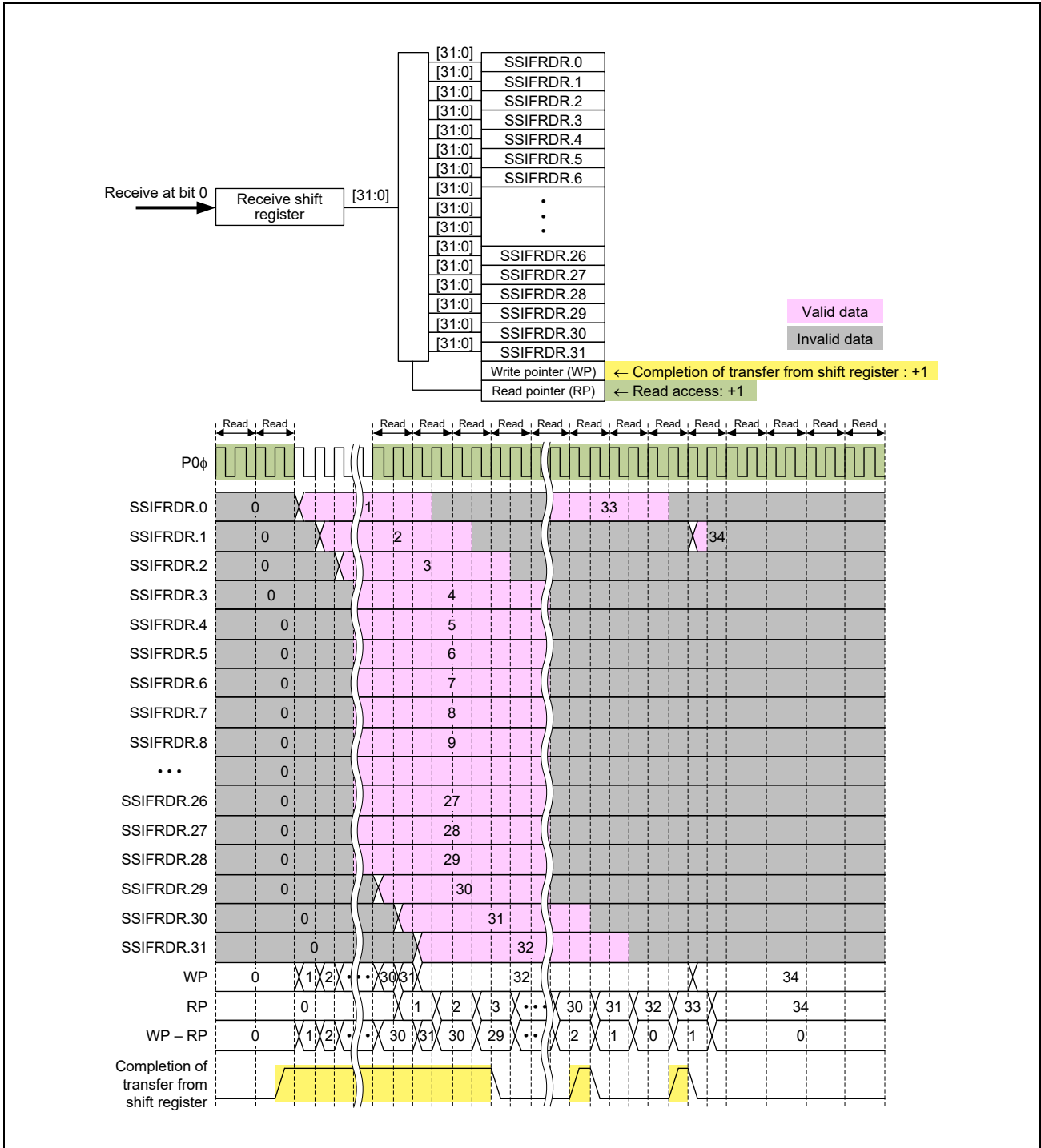

Figure 27.31 Configuration of the Receive FIFO Data Register and Receive Shift Register, and FIFO Operation Example

27.4.1.7 Audio Format Register (SSIOFR)

This is a readable/writable 32-bit register. It sets an audio format including the communication format, LRCK/FS continuation mode, and BCK output stop.

Bit	31	30	29	28	27	26	25	24	23	22	21	20	19	18	17	16
	—	—	—	—	—	—	—	—	—	—	—	—	—	—	—	—
Initial Value	0	0	0	0	0	0	0	0	0	0	0	0	0	0	0	0
R/W	R	R	R	R	R	R	R	R	R	R	R	R	R	R	R	R
Bit	15	14	13	12	11	10	9	8	7	6	5	4	3	2	1	0
	—	—	—	—	—	—	BCKST P	LRCON T	—	—	—	—	—	—	OMOD[1:0]	
Initial Value	0	0	0	0	0	0	0	0	0	0	0	0	0	0	0	0
R/W	R	R	R	R	R	R	R/W	R/W	R	R	R	R	R	R	R/W	R/W

Bit	Bit Name	Initial Value	R/W	Description
31 to 10	—	H'000000	R	Reserved. Write 0. The read value is 0.
9	BCKASTP	0	RW	BCK Output Stop Enable* ^{1,*2} 0: Enables output of BCK 1: Disables output of BCK
8	LRCONT	0	RW	LRCK/FS Continuation Enable* ^{1,*2} 0: Disables LRCK continuation 1: Enables LRCK continuation
7 to 2	—	H'00	R	Reserved. Write 0. The read value is 0.
1, 0	OMOD[1:0]	0	RW	Audio Format Select* ^{3,*4} OMOD[1:0]: Format 00: I ² S format 01: TDM format 10: Monaural format 11: Setting prohibited

Note 1. This bit is valid only in master-mode communication (SSICR.MST = 1). The setting is invalid in slave-mode communication (SSICR.MST = 0).

Note 2. BCKASTP=1 and LRCONT=1 is prohibitions.

Note 3. Writing in this bit is a prohibition when SSIF-2 is communication state (SSISR.IIRQ=0). Operation is not guaranteed when rewriting it.

Note 4. Use the communication format setting that can be communicated when the format of the communication of the opposing device is compatible format of SSIF-2.

BCKASTP Bit

This bit turns on or off the function to output BCK to the SSIBCK pin according to the communication shown in **Figure 27.32** and **Figure 27.33** in master-mode communication (SSICR.MST = 1). Set this bit after setting completing the communication format.

This bit must defend the following usage. Start communication with BCKASTP = 0, and set 1 to BCKASTP while communicating. As a result, the bit clock output to the terminal SSIBCK stops by the automatic operation when the communication stop is done. When you will restart the communication, set 0 to BCKASTP with idle state (SSICR.IIRQ=1) and the AUDIO_MCK supply state (SSIFCR.AUCKE = 1)

When master communication (SSICR.MST=1) and idle state (SSICR.IIRQ=1).

Table 27.11 BCKASTP state, and Output state of SSIBCK pin.

BCKASTP bit	output state of SSIBCK pin
0	Enable
1	Disable

Note: When the opposing device who is the slave needs the clock of the terminal SSIBCK before the communication operates, it is not possible to use it. Use it to stop clocking after the communication ends (Figure 27.33). Refer to Figure 27.32 for timing that the function becomes effective.

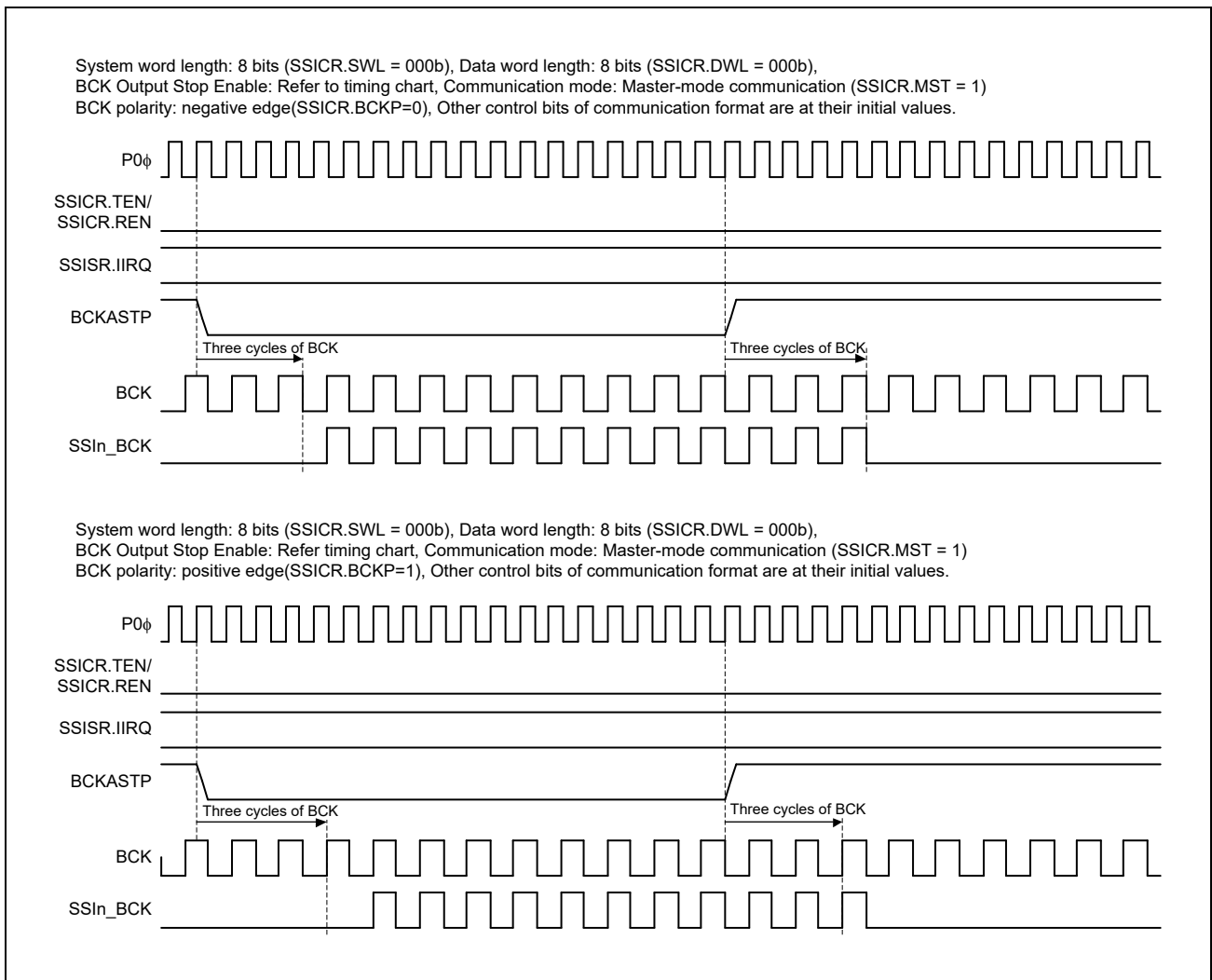

Figure 27.32 Example Operation of the BCKASTP Bit (in idle state)

When master communication (SSICR.MST=1) and the BCK output automatic operation stop function (BCKASTP = 1) (Figure 27.33).

Details of the BCK output to SSIBCK pin are as follows.

- Output start timing: To generate an effective edge in timing that LRCK/FS is changed into the valid value, BCK is output.
- Output stop timing: Frame boundary from 1 to 1.5 clock

Refer to the timing chart of **Figure 27.33** for detailed timing.

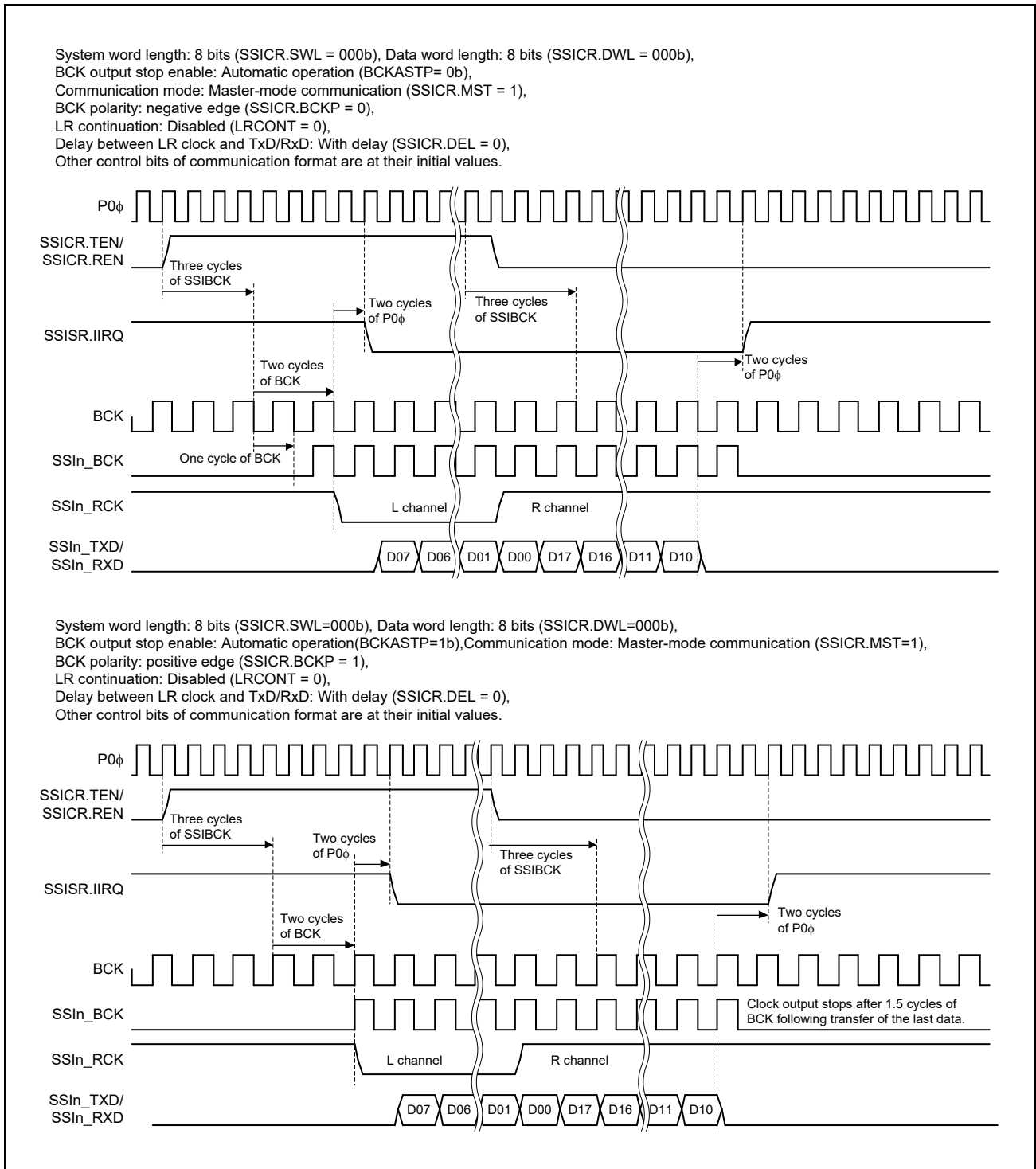

Figure 27.33 Example Operation of the BCKASTP Bit (Communication behavior in BCKASTP=1)

LRCONT Bit

This bit enables/disables the output from the SSILRCK/SSIFS pin when SSIF-2 is master communication (SSICR.MST=1) and idle state (SSISR.IIRQ=1). Writing 1 to this bit (enables LRCK/FS continuation) in master mode (SSICR.MST = 1) enables continuation of the output from the SSILRCK/SSIFS pins even when idle state.

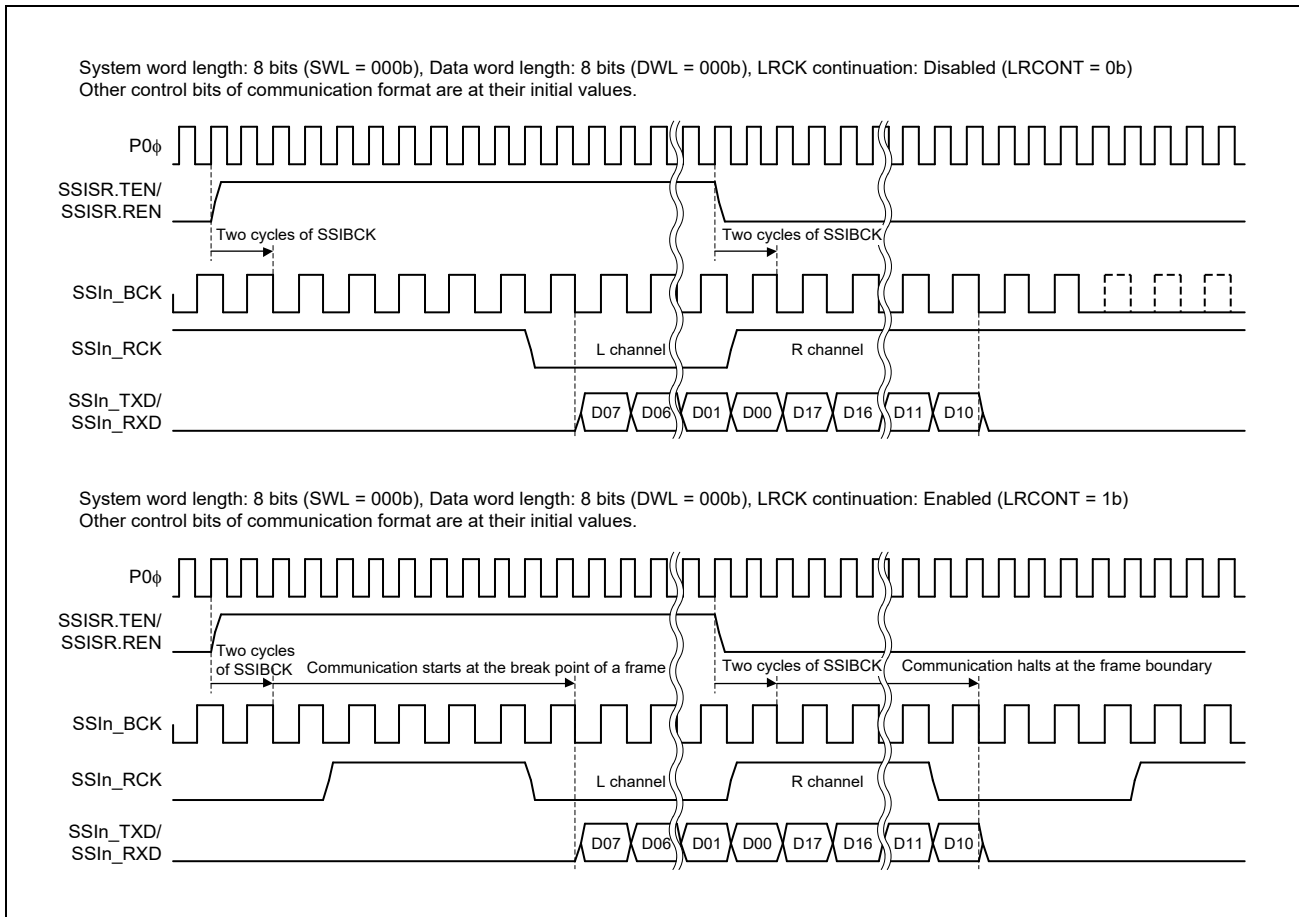

Figure 27.34 Operation Example of LRCK/FS Continuation (in idle state)

OMOD[1:0] Bits

These bits set an audio format.

Rewrite this bit when the LR clock supply to the terminal SSILRCK stops. Refer to the LRCONT bit details explanation in **Section 27.4.1.7, Audio Format Register (SSIOFR)** for the output operation of the LR clock.

27.4.1.8 Status Control Register (SSISCR)

This is a readable/writable 32-bit register. It sets the operation of the TDE and RDF flags.

Bit	31	30	29	28	27	26	25	24	23	22	21	20	19	18	17	16
	—	—	—	—	—	—	—	—	—	—	—	—	—	—	—	—
Initial Value	0	0	0	0	0	0	0	0	0	0	0	0	0	0	0	0
R/W	R	R	R	R	R	R	R	R	R	R	R	R	R	R	R	R
Bit	15	14	13	12	11	10	9	8	7	6	5	4	3	2	1	0
	—	—	—	TDES[4:0]				—	—	—	RDFS[4:0]					
Initial Value	0	0	0	0	0	0	0	0	0	0	0	0	0	0	0	0
R/W	R	R	R	R/W	R/W	R/W	R/W	R/W	R	R	R	R/W	R/W	R/W	R/W	R/W

Bit	Bit Name	Initial Value	R/W	Description
31 to 13	—	H'00000	R	Reserved. Write 0. The read value is 0.
12 to 8	TDES[4:0]	H'00	RW	TDE Setting Condition Select* ¹ TDES[4:0]: Operation 00000b: SSIFTDR has one stage or more free space 00001b: SSIFTDR has two stages or more free space (snip) 11110b: SSIFTDR has thirty-one stages or more free space 11111b: SSIFTDR has thirty-two stages or more free space
7 to 5	—	H'0	R	Reserved. Write 0. The read value is 0.
4 to 0	RDFS[4:0]	H'00	RW	RDF Setting Condition Select* ¹ RDFS[4:0]: Operation 00000b: SSIFRDR has one stage or more data size 00001b: SSIFRDR has two stages or more data size (snip) 01110b: SSIFRDR has thirty-one or more data size 01111b: SSIFRDR has thirty-two stages or more data size

Note 1. Writing to these bits while SSIF-2 is in a communication state (SSISR.IIRQ = 0) is prohibited. If written, the operation performed immediately after writing is not guaranteed.

TDES[4:0] Bits

These bits set the setting condition of the transmit data empty flag (TDE). Set these bits in byte units.

RDFS[4:0] Bits

These bits set the setting condition of the receive data full flag (RDF). Set these bits in byte units.

27.4.2 Communication Formats

SSIF-2 supports three communication formats (**Table 27.12**).

Table 27.12 Supported Communication Formats

Communication Format	SSIOFR.OMOD[1:0]
I ² S format	00
TDM format	01
Monaural format	10

The following figure shows the serial data configuration common to communication formats. Serial data is determined according to the system word length (SSICR.SWL[2:0]) and the data word length (SSICR.DWL[2:0]). When the system word length is longer than the data word length, padding bits are transferred (**Figure 27.35**).

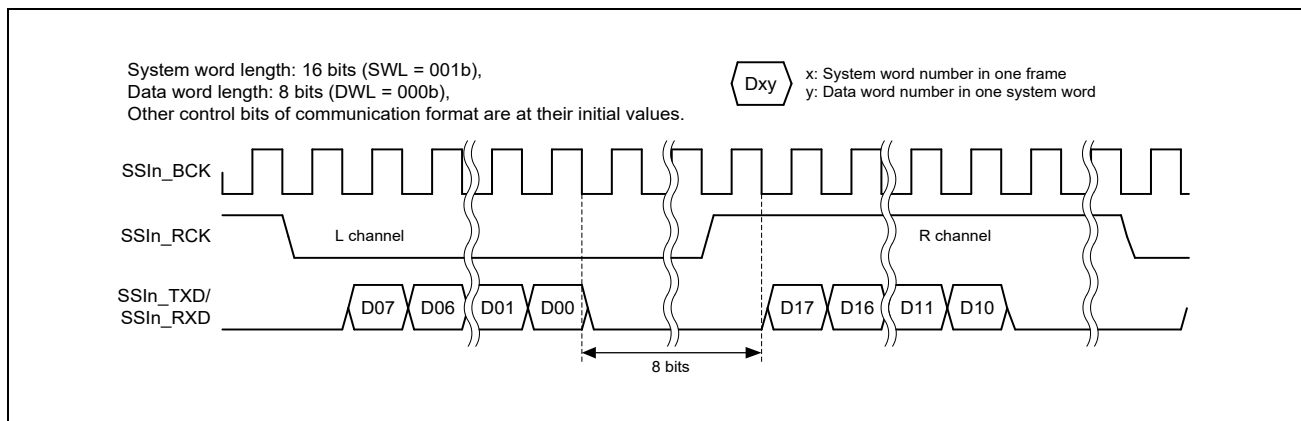

Figure 27.35 Example of Padding Bit Transfer (I²S Format: System Word Length > Data Word Length)

Table 27.13 lists the number of padding bits to be transferred with each combination of system word length (SSICR.SWL[2:0]) and data word length (SSICR.DWL[2:0]). “-” indicates that the setting is prohibited.

Table 27.13 Number of Padding Bits

SSICR.DWL[2:0]		000b	001b	010b	011b	100b	101b	110b	111b
SSICR.SWL[2:0]	System Word Length	8	16	18	20	22	24	32	Set prohibition
000b	8	0	—	—	—	—	—	—	—
001b	16	8	0	—	—	—	—	—	—
010b	24	16	8	6	4	2	0	—	—
011b	32	24	16	14	12	10	8	0	—
100b	48	40	32	30	28	26	24	16	—
101b	64	56	48	46	44	42	40	32	—
110b	128	120	112	110	108	106	104	96	—
111b	256	248	240	238	236	234	232	224	—

27.4.2.1 I²S Format

The I²S format is a communication format used for connection with I²S-compatible serial devices. With this format setting (SSIOFR.OMOD[1:0] = 00b), one frame is configured with two system words, one for the channel L and the other for channel R. The SSILRCK/SSIFS signals are at a low level for the channel L and at a high level for the channel R. Set the polarity of the signals with the SSICR.LRCKP bit. **Figure 27.36** shows the I²S format without padding. See **Figure 27.35** for the format with padding.

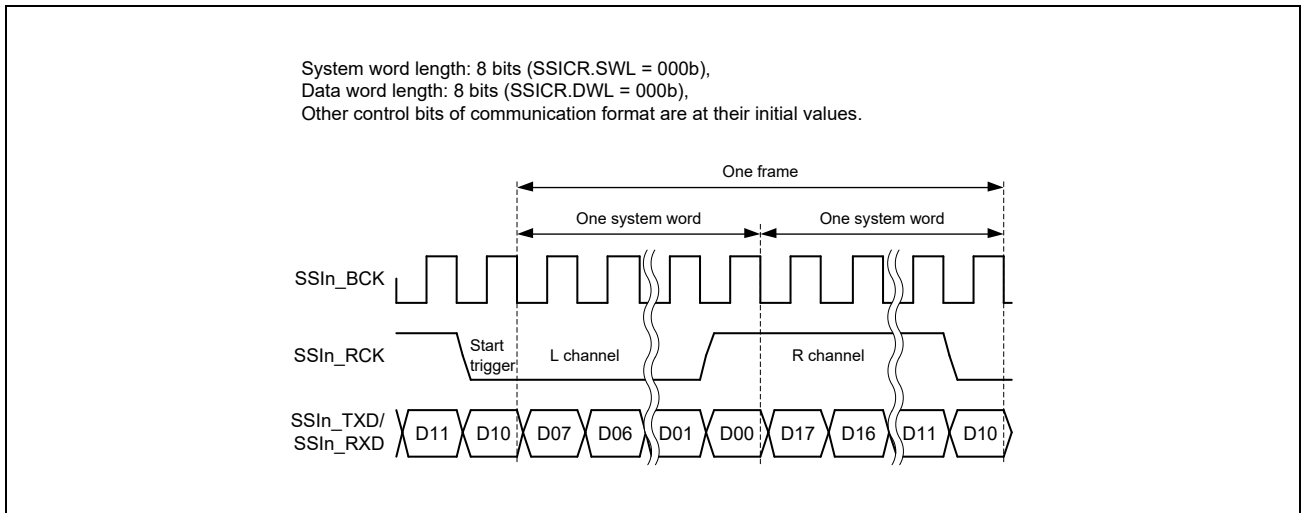

Figure 27.36 I²S Format (Without Padding: System Word Length = Data Word Length)

For the state of external pins when SSIF-2 is in the idle state, see **Section 27.5.1.1, Idle State**.

NOTE

SSIF-2 has the terminal SSILRCK/SSIFS that shows the synchronization of the communication. Match communication format of the opposing device and SSIF-2 when SSIF-2 is slave communication (SSICR.MST=0). SSIF-2 uses the signal of SSILRCK/ SSIFS only as a communication start trigger.

27.4.2.2 Monaural Format

The monaural format is a communication format used for connection with monaural-compatible serial devices. With this format setting (SSIOFR.OMOD[1:0] = 10b), one frame is configured with the number of system words set with the SSICR.FRM[1:0] bits (**Figure 27.37**). A rising of the SSILRCK/SSIFS signal means a start trigger. **Figure 27.37** and **Figure 27.38** respectively show the monaural formats without and with padding.

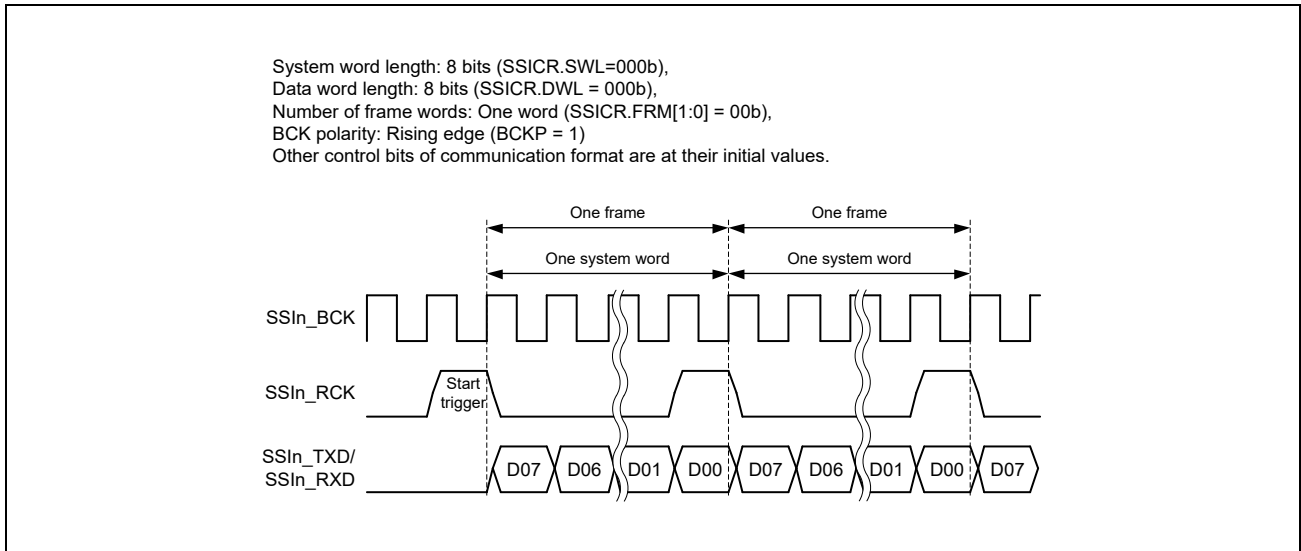

Figure 27.37 Short Frame in Monaural Format (Without Padding: System Word Length = Data Word Length)

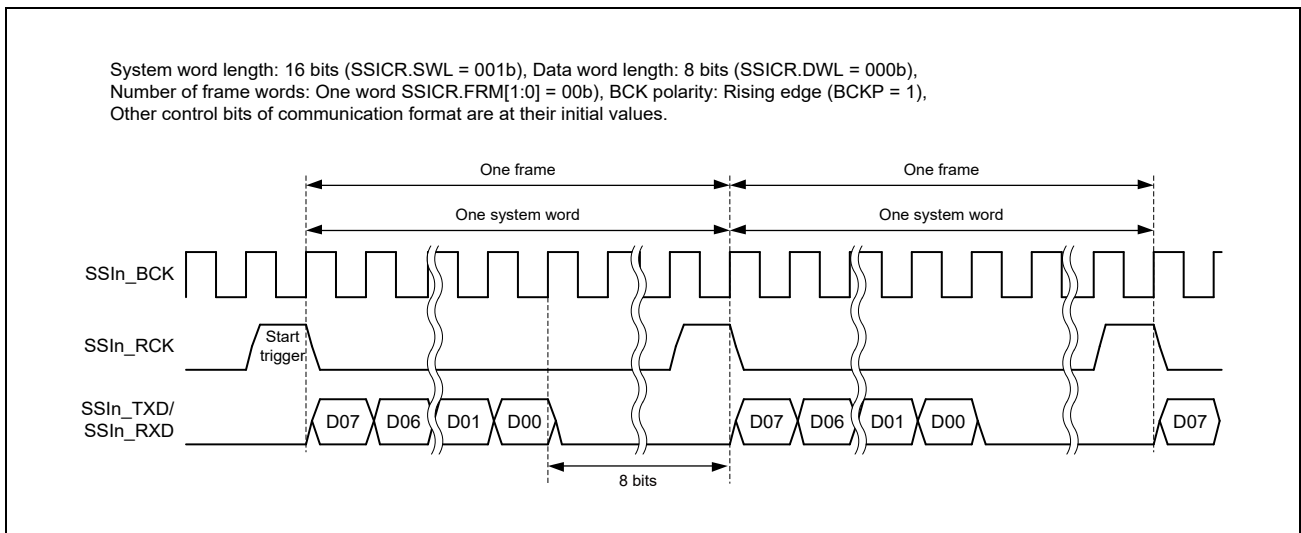

Figure 27.38 Short Frame in Monaural Format (With Padding: System Word Length > Data Word Length)

The monaural formats supported by SSIF-2 consist of short frames and long frames. See **Section 27.4.2.2(1), Short Frame** and **Section 27.4.2.2(2), Long Frame** for the difference between these two frames.

For the state of external pins state when SSIF-2 is in the idle state, see **Section 27.5.1.1, Idle State**.

NOTE

SSIF-2 has the terminal SSILRCK/SSIFS that shows the synchronization of the communication. Match communication format of the opposing device and SSIF-2 when SSIF-2 is slave communication (SSICR.MST=0). SSIF-2 uses the signal of SSILRCK/SSIFS only as a communication start trigger.

(1) Short Frame

With the short frame (SSICR.DEL = 0), the SSILRCK/SSIFS signal that indicates a start of serial data is at a high level for one cycle of SSIBCK. Data transfer starts at the falling edge of the signal (**Figure 27.37** and **Figure 27.38**).

(2) Long Frame

With the long frame (SSICR.DEL = 1), the SSILRCK/SSIFS signal that indicates a start of serial data is at a high level for two cycles of SSIBCK. Data transfer starts at the rising edge of the signal (**Figure 27.39**).

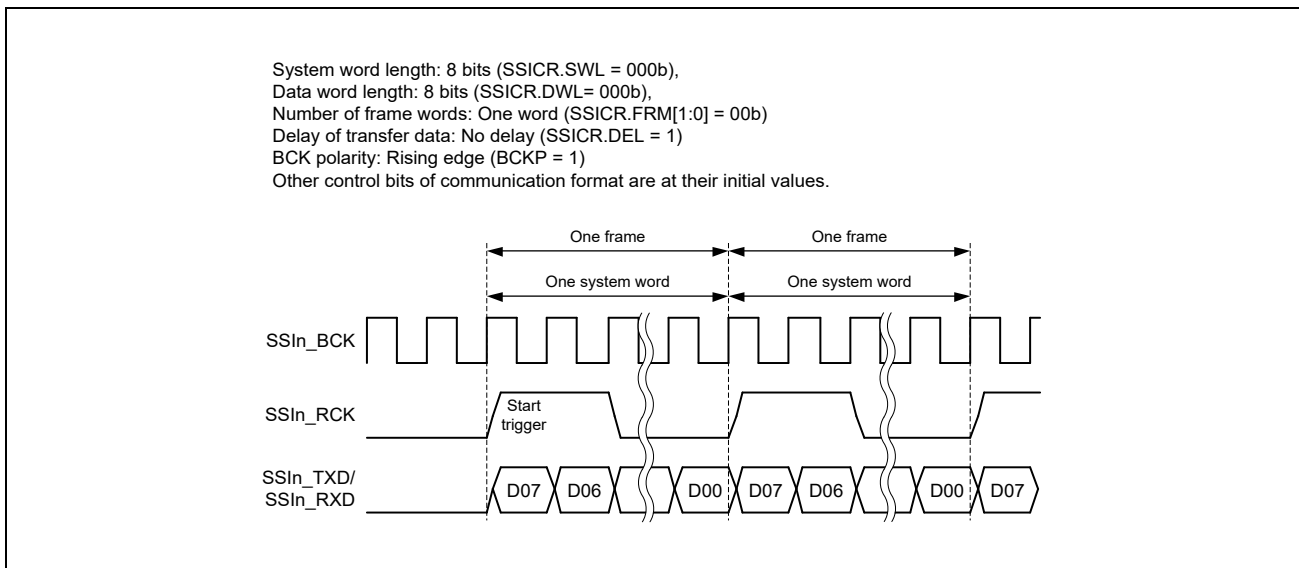

Figure 27.39 Long Frame in Monaural Format (Without Padding)

27.4.2.3 TDM Format

The TDM format is a communication format used for connection with TDM-compatible multi-channel devices. With this format setting (SSIOFR.OMOD[1:0] = 01b), one frame is configured with four to eight system words set with the SSICR.FRM[1:0] bits. With this format, the SSILRCK/SSIFS signal is at a high level for the first one system word and at a low level for the rest. The pulse generated on the SSILRCK/SSIFS signal is defined as the SYNC pulse and its rising edge means a start of one frame. **Figure 27.40** and **Figure 27.41** respectively show the TDM formats with and without padding.

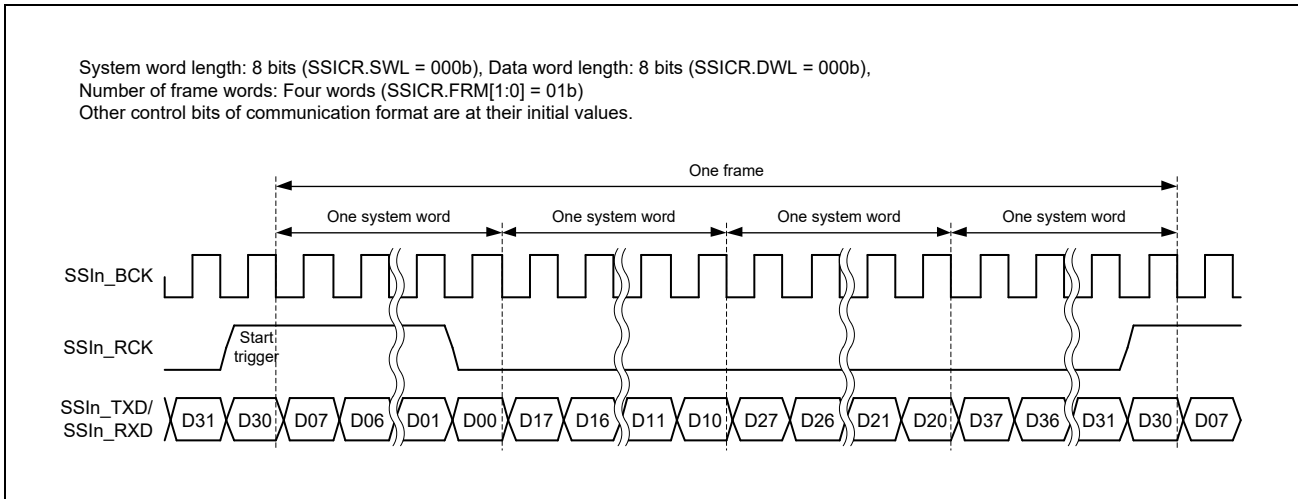

Figure 27.40 TDM Format (Without Padding: System Word Length = Data Word Length)

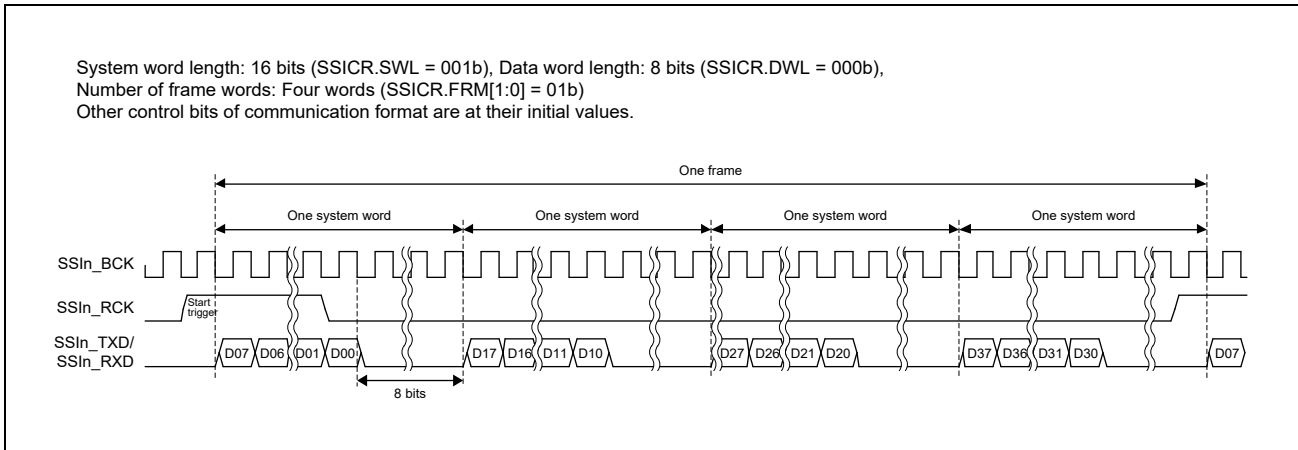

Figure 27.41 TDM Format (With Padding: System Word Length > Data Word Length)

For the state of external pins when SSIF-2 is in the idle state, see **Section 27.5.1.1, Idle State**.

NOTE

SSIF-2 has the terminal SSILRCK/SSIFS that shows the synchronization of the communication. Match communication format of the opposing device and SSIF-2 when SSIF-2 is slave communication (SSICR.MST=0). SSIF-2 uses the signal of SSILRCK/SSIFS only as a communication start trigger.

27.4.3 Communication Modes

SSIF-2 supports the following communication modes. **Table 27.15** lists the control bits that are not available with each communication mode. See **Section 27.4.3.1** to **Section 27.4.3.5** for details of these communication modes.

Table 27.14 Communication Modes

Communication Mode	SSICR.MST Bit	SSICR.REN Bit	SSICR.TEN Bit
Slave-mode transmission	0	0	1
Slave-mode reception	0	1	0
Slave-mode transmission and reception	0	1	1
Master-mode transmission	1	0	1
Master-mode reception	1	1	0
Master-mode transmission and reception	1	1	1

Table 27.15 Control Bits that Cannot be Used in Each Communication Mode

Communication Mode Control Bit	Slave-mode Reception	Slave-mode Transmission	Slave-mode Transmission and Reception	Master-mode Reception	Master-mode Transmission	Master-mode Transmission and Reception
SSICR.CKS	Invalid	Invalid	Invalid	Available	Available	Available
SSICR.CKDV	Invalid	Invalid	Invalid	Available	Available	Available
SSICR.MUEN	Invalid	Available	Available	Invalid	Available	Available
SSICR.TEN	Invalid	Available	Available	Invalid	Available	Available
SSICR.REN	Available	Invalid	Available	Available	Invalid	Available
SSIFCR.AUCKEN	Invalid	Invalid	Invalid	Available	Available	Available
SSIFCR.BCKNCE	Available	Available* ¹	Available* ²	Invalid	Invalid	Invalid
SSIFCR.LRCKNCE	Available	Available* ¹	Available* ²	Invalid	Invalid	Invalid
SSIFCR.RXDNCE	Available	Invalid	Available	Invalid	Invalid	Invalid
SSIFCR.TIE	Invalid	Available	Available	Invalid	Available	Available
SSIFCR.RIE	Available	Invalid	Available	Available	Invalid	Available
SSIFCR.TFRST	Invalid	Available	Available	Invalid	Available	Available
SSIFCR.RFRST	Available	Invalid	Available	Available	Invalid	Available
SSIOFR.BCKASTP	Invalid	Invalid	Invalid	Available	Available	Available
SSIOFR.LRCONT	Invalid	Invalid	Invalid	Available	Available	Available
SSIOFR.OMOD	Available	Available	Available	Available	Available	Available
SSISCR.TDES	Invalid	Available	Available	Invalid	Available	Available
SSISCR.RDFS	Available	Invalid	Available	Available	Invalid	Available

Note 1. Disabled when SSICR.DEL = '1'

Note 2. Note 2. Disabled during transmission (SSICR.TEN = '1') when SSICR.DEL = '1'

27.4.3.1 Slave-mode Communication

SSIF-2 operates in slave mode with SSICR.MST = 0. Supply the SSIBCK signal and the SSILRCK/SSIFS signal used for the serial data communication from external devices. If these signals do not match the communication format set for SSIF-2, operation is not guaranteed.

27.4.3.2 Master-mode Communication

SSIF-2 operates in master mode with SSICR.MST = 1. The SSIBCK signal and SSILRCK/SSIFS signal used for the serial data communication are internally generated from the audio clock. These signals use the format according to the setting of SSIF-2. If the communication format of another device working as the slave device does not match the communication format set for SSIF-2, operation is not guaranteed.

27.4.3.3 Transmission

SSIF-2 transmits serial data to opposing device when SSICR.TEN = 1 and SSICR.REN = 0. If the communication format of the opposing device does not match the communication format set for SSIF-2, operation is not guaranteed.

27.4.3.4 Reception

SSIF-2 receives serial data from opposing device when SSICR.TEN = 0 and SSICR.REN = 1. If the communication format of the opposing device does not match the communication format set for SSIF-2, operation is not guaranteed.

27.4.3.5 Transmission and Reception

SSIF-2 transmits and receives serial data to and from opposing device when SSICR.TEN = 1, SSICR.REN = 1. If the communication format of opposing device does not match the communication format set for SSIF-2, operation is not guaranteed.

27.5 Operation

27.5.1 Operational State

SSIF-2 has the following two main operation states (**Figure 27.42**).

- Idle state (SSISR.IIRQ = 1)
- Communication state (SSISR.IIRQ = 0)

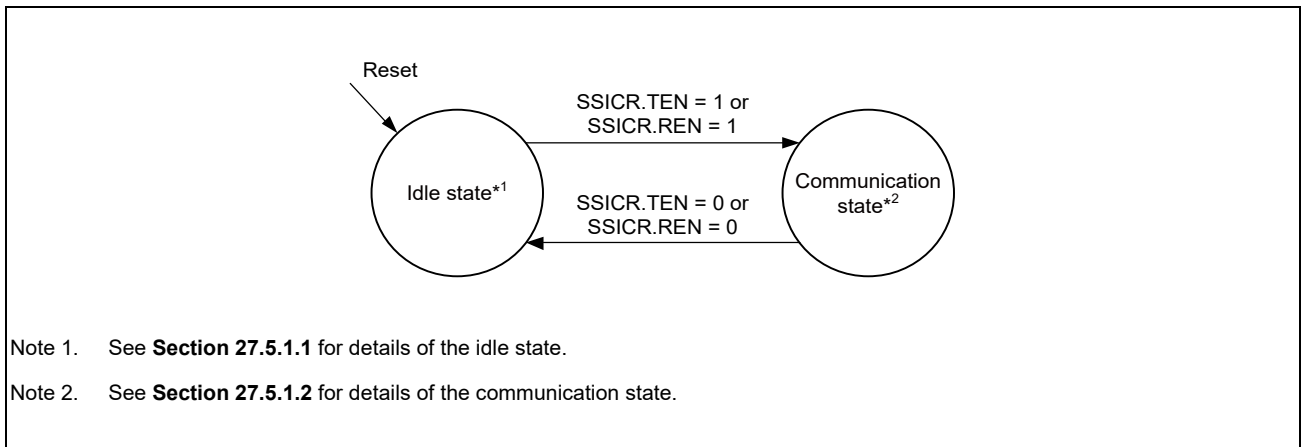

Figure 27.42 SSIF-2 State Transition

27.5.1.1 Idle State

In this state, communication of SSIF-2 is halted. However, when SSICR.MST = 1, output of BCK and LRCK/FS to external pins is enabled depending on the settings in the SSIOFR.BCKASTP bit and the SSIOFR.LRCONT bit (**Table 27.16**). This function is common to all formats.

Table 27.16 Output from External Pins in the Idle State

SSICR.MST	SSIOFR.BCKASTP	SSIOFR.LRCONT	Output from Pins		
			SSIBCK	SSILRCK/SSIFS	SSITxD
0	—	—	Stop	Stop	Stop
1	0	0	Supply	Stop	Stop
1	0	1	Supply	Supply	Stop
1	1	0	Stop	Stop	Stop
1	1	1	Stop	Supply	Stop

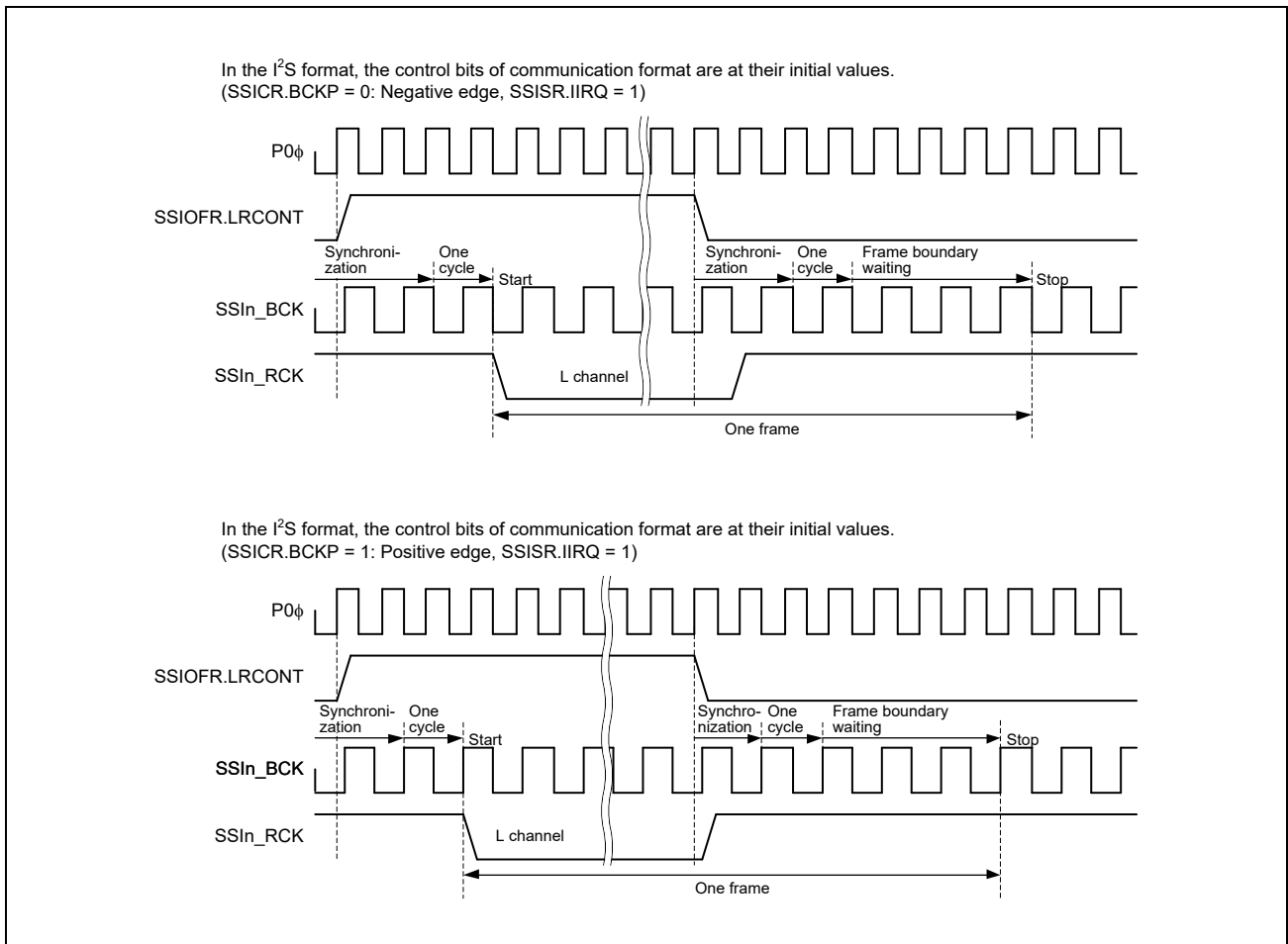

Figure 27.43 Example of LRCK/FS Continuation Release with SSIOFR.LRCONT

NOTE

To stop the output to the SSILRCK/SSIFS pin with SSIOFR.LRCONT when SSIF-2 is in the idle state in master-mode communication (SSICR.MST = 1), note the following: The output stops when 0 is written from 1 to SSIOFR.LRCONT. (Figure 27.43). Make sure that the remote device is not affected.

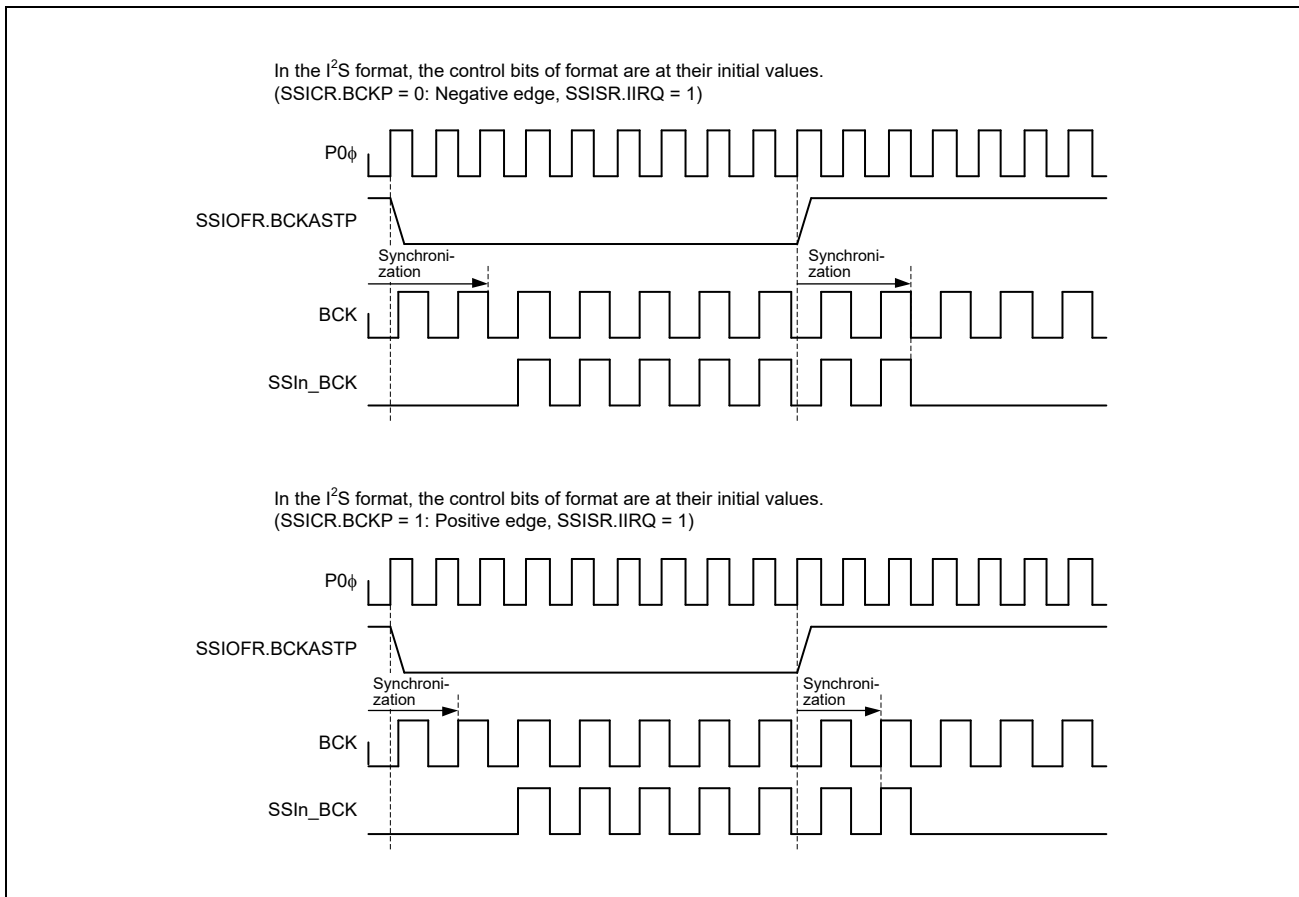

Figure 27.44 Example of Stopping SSIBCK with SSIOFR.BCKASTP

NOTE

To stop the output to the SSIBCK pin with SSIOFR.BCKASTP in master-mode communication (SSICR.MST = 1) and while SSIF-2 is in the idle state, note the following; By writing 0 to SSIOFR.BCKASTP while it is 1, the output stops immediately (**Figure 27.44**). So, make sure that the remote device is not affected.

27.5.1.2 Communication States

In this state, SSIF-2 is during communication. **Figure 27.45** shows transitions of communication states and **Table 27.17** lists the conditions for transition. If the transition condition is not satisfied, the state does not transit.

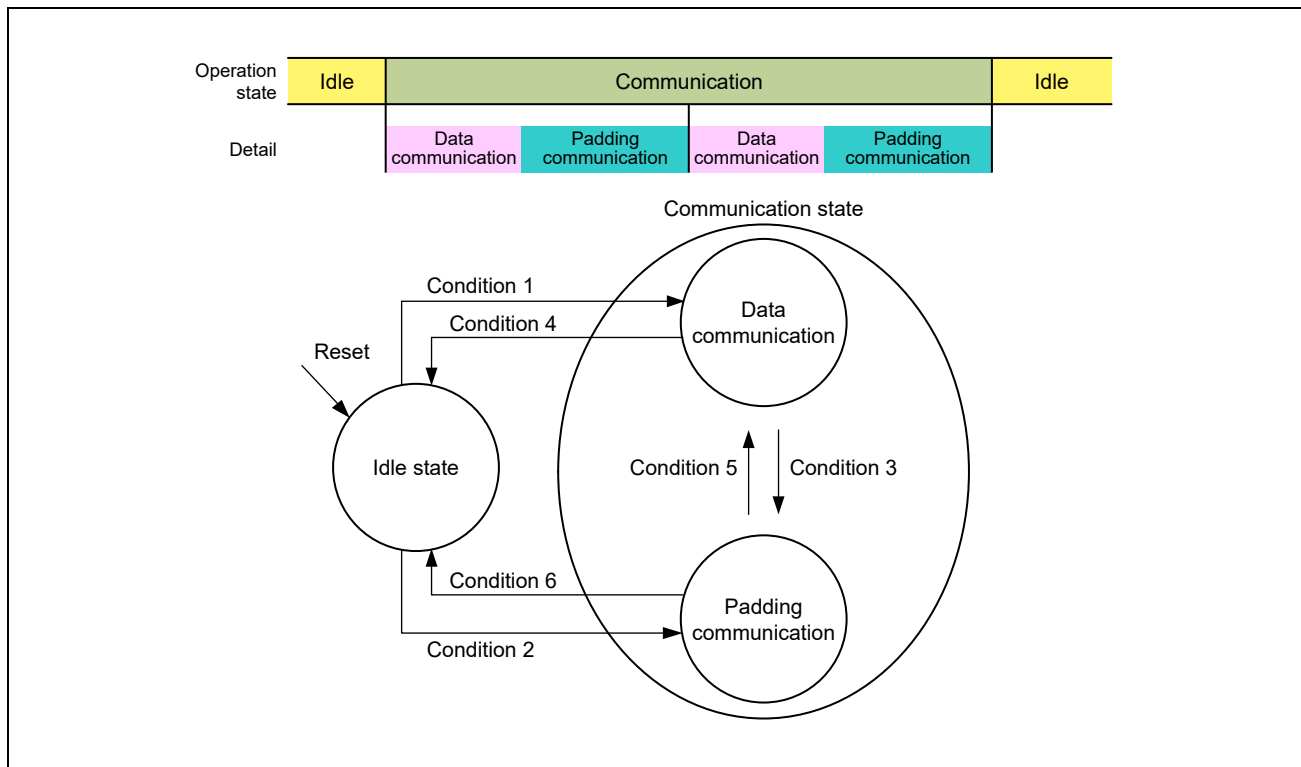

Figure 27.45 Communication State Transition

Table 27.17 Condition for Communication State Transition

Condition No.	Condition for Transition
1	Writing SSICR.TEN = 1 or SSICR.REN = 1 while SSICR.SDTA = 0 or in the setting without padding bits.
2	Writing SSICR.TEN = 1 or SSICR.REN = 1 while SSICR.SDTA = 1 and in the setting with padding bits.
3	The following all of three conditions are satisfied: <ul style="list-style-type: none"> • SSICR.TEN = 1 or SSICR.REN = 1 • In the setting without padding bits • Transfer data words of the last data bit is completed.
4	The following all of two conditions are satisfied: <ul style="list-style-type: none"> • SSICR.SDTA = 1 or without padding bits • Transfer data words of the last data bit of one frame is completed while SSICR.TEN = 0 and SSICR.REN = 0
5	Transfer of the last padding bit is completed while SSICR.TEN = 1 or SSICR.REN = 1
6	The following all of two conditions are satisfied: <ul style="list-style-type: none"> • SSICR.SDTA = 0 and with padding bits • Transfer of the last data bit of one frame is completed while SSICR.TEN = 0 and SSICR.REN = 0.

See **Table 27.13** for the setting with/without padding bits.

(1) Data Communication State

In this state, SSIF-2 is during communication. Data of the data word length set with the SSICR.DWL[2:0] bits is transmitted, received, or transmitted and received.

State Transition in the Setting without Padding Bits

During communication (SSISR.IIRQ = 0), SSIF-2 is during data communication for all the time (**Figure 27.46**). By disabling transmission and reception (SSICR.TEN = 0 and SSICR.REN = 0), SSIF-2 transits to the idle state (**Figure 27.47**).

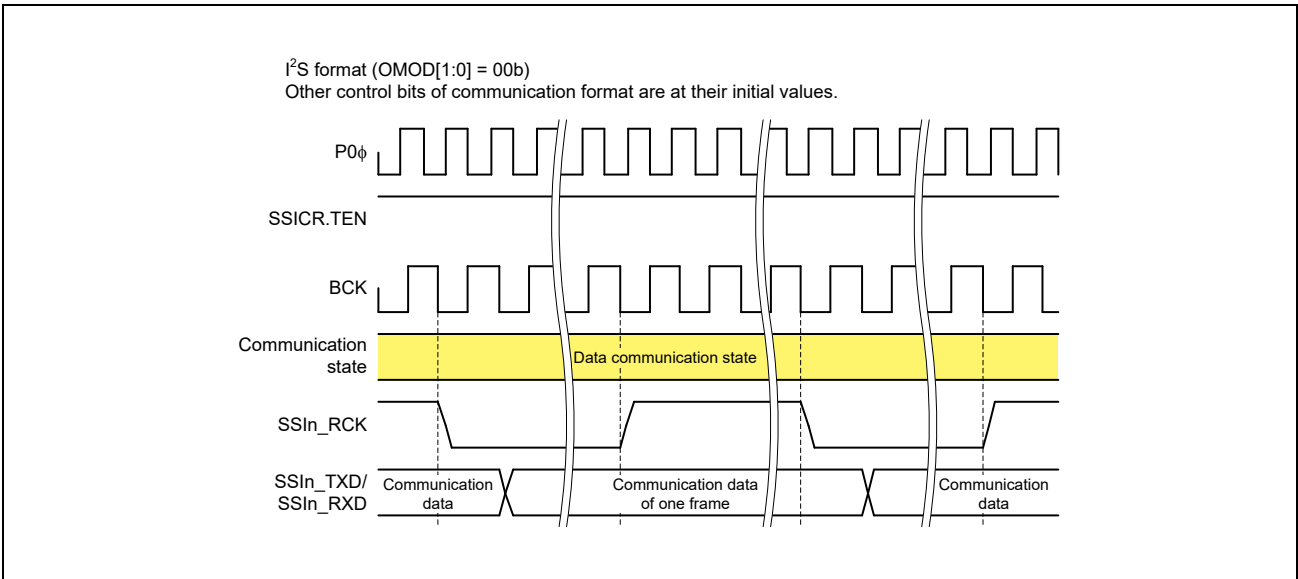

Figure 27.46 Continuation of the Data Communication State

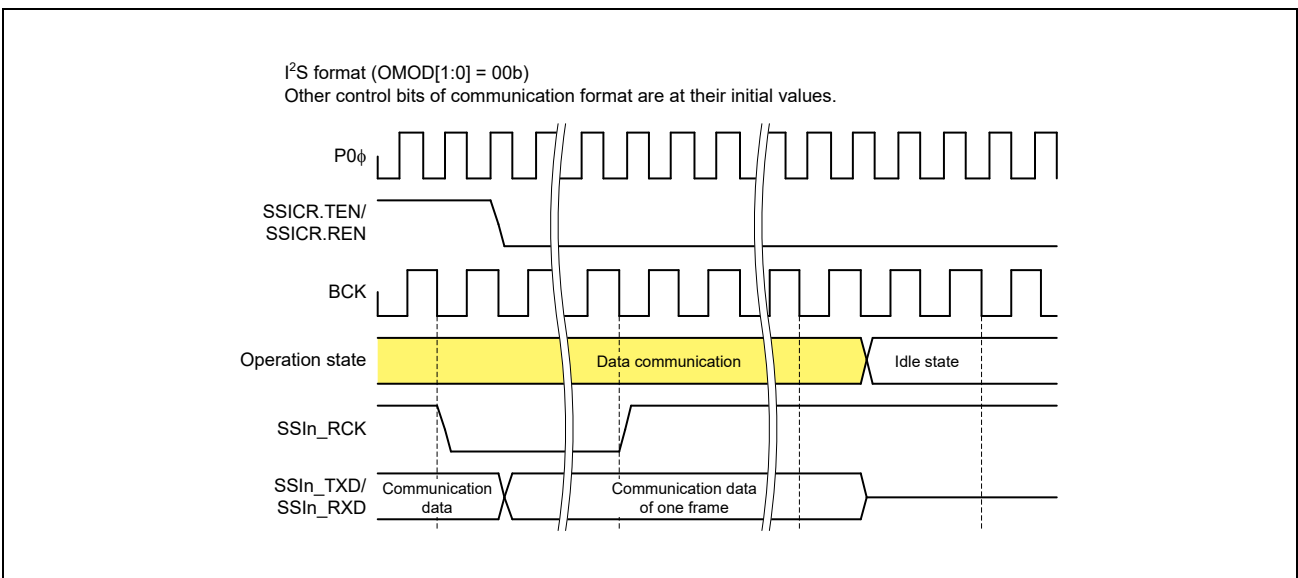

Figure 27.47 Halt from the Data Communication State (without Padding Bits)

State Transition in the Setting with Padding Bits

During communication (SSISR.IIRQ = 0), after completing transfer of the last bit of a data word, SSIF-2 transits to the padding communication state from data communication state (**Figure 27.48**). By disabling transmission and reception (SSICR.TEN = 0 and SSICR.REN = 0) while SSICR.SDTA = 1, SSIF-2 transits to the idle state from data communication state when the communication stop is done. (**Figure 27.49**).

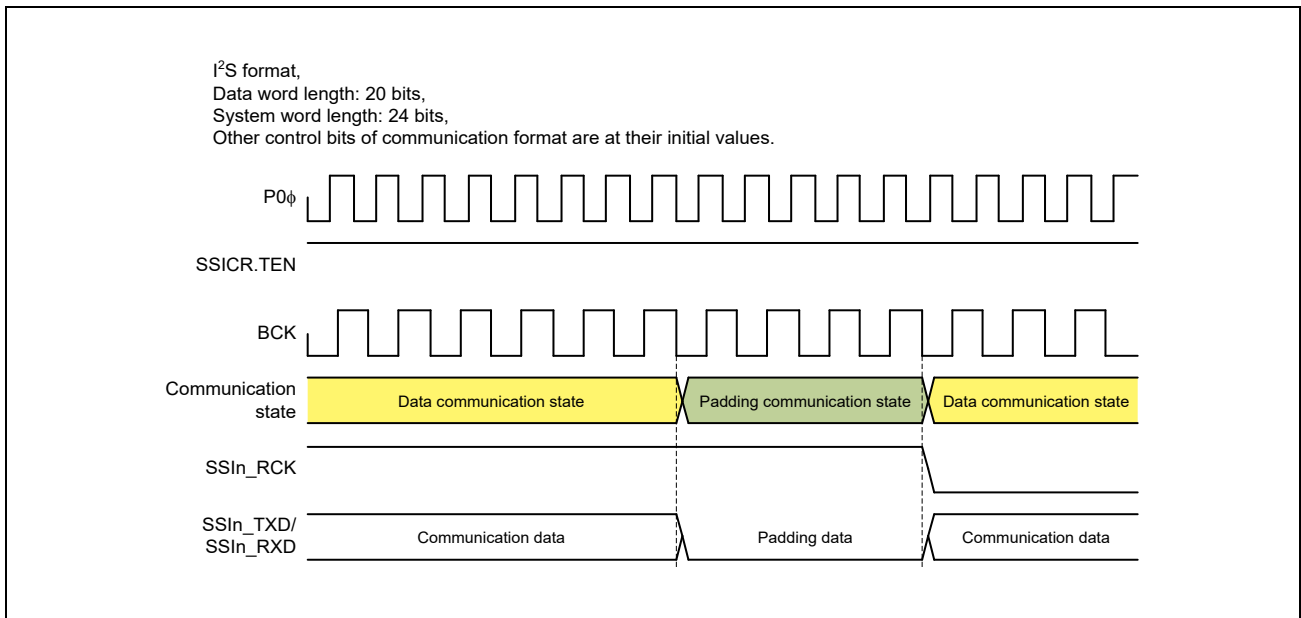

Figure 27.48 Transition from Data Communication to Padding Communication

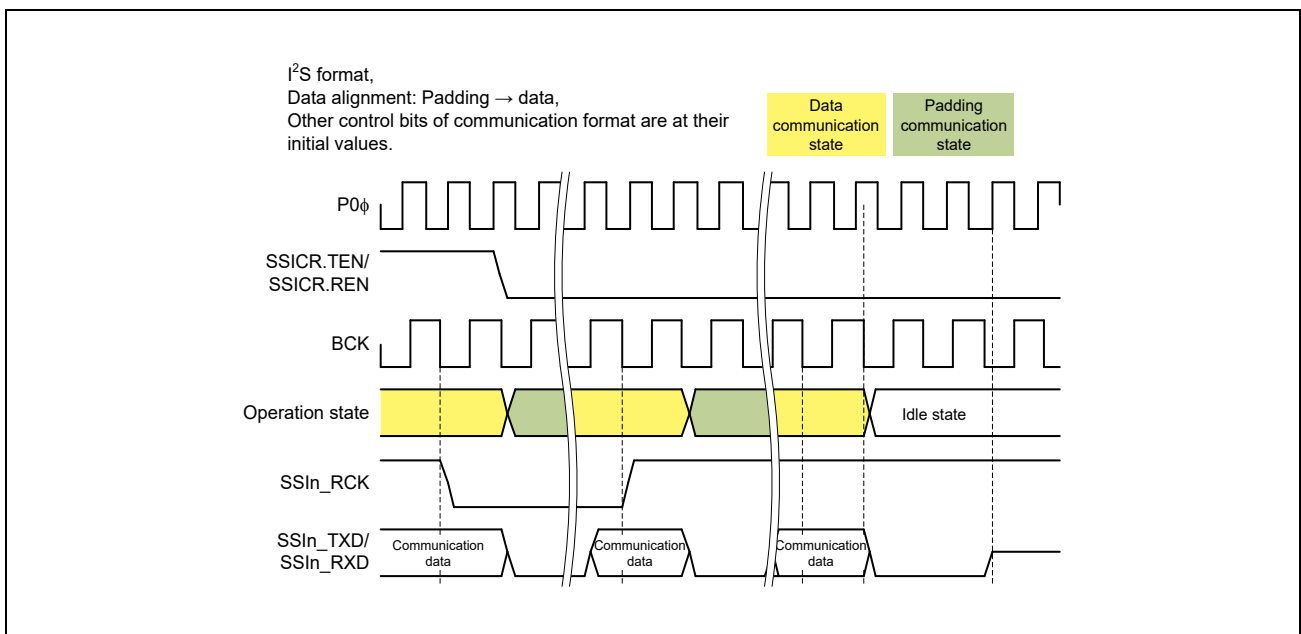

Figure 27.49 Halt from Data Communication (with Padding Bits)

(2) Padding Communication State

In this state, SSIF-2 is during communication. The padding bits set with the SSICR.SWL[2:0] bits and SSICR.DWL[2:0] bits are transmitted, received, or transmitted and received.

State Transition in the Setting with Padding Bits

During communication (SSISR.IIRQ = 0), after completing transfer of the last padding bit, SSIF-2 transits to data communication state (**Figure 27.48**). By disabling transmission and reception (SSICR.TEN = 0 and SSICR.REN = 0) while SSICR.SDTA = 0, SSIF-2 transits to the idle state from padding communication when the communication stop is done. (**Figure 27.50**).

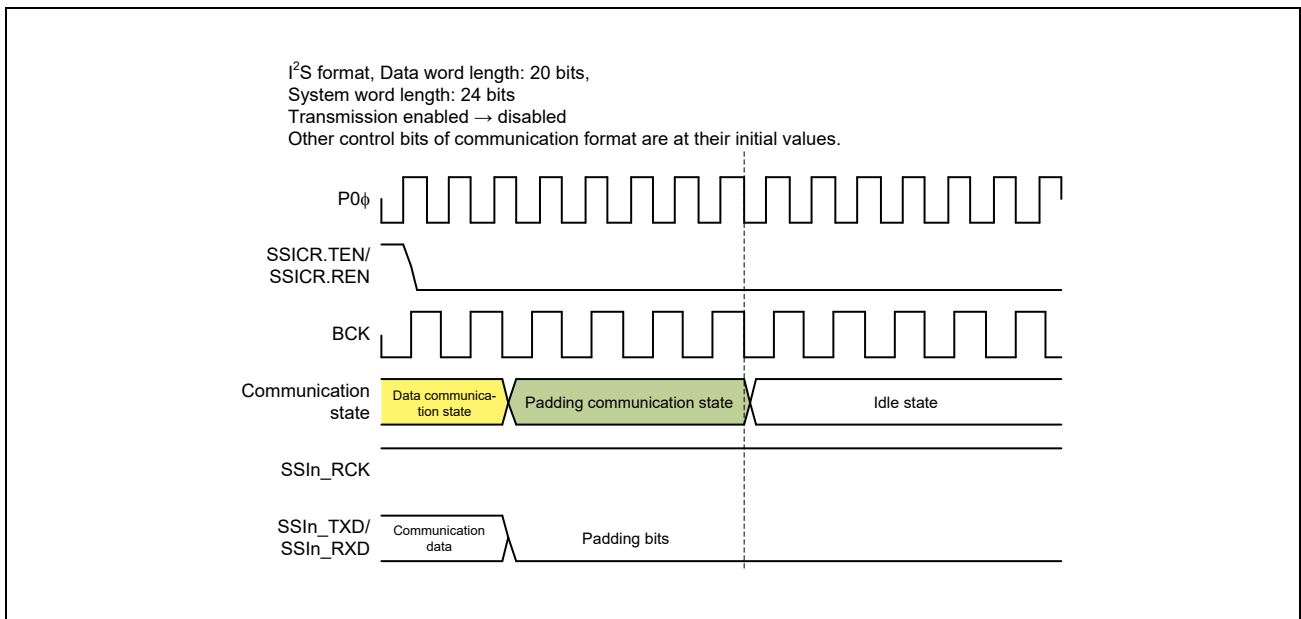

Figure 27.50 Halt from the Padding Communication State

27.5.2 Communication Operation

Figure 27.51 shows the communication flow of SSIF-2.

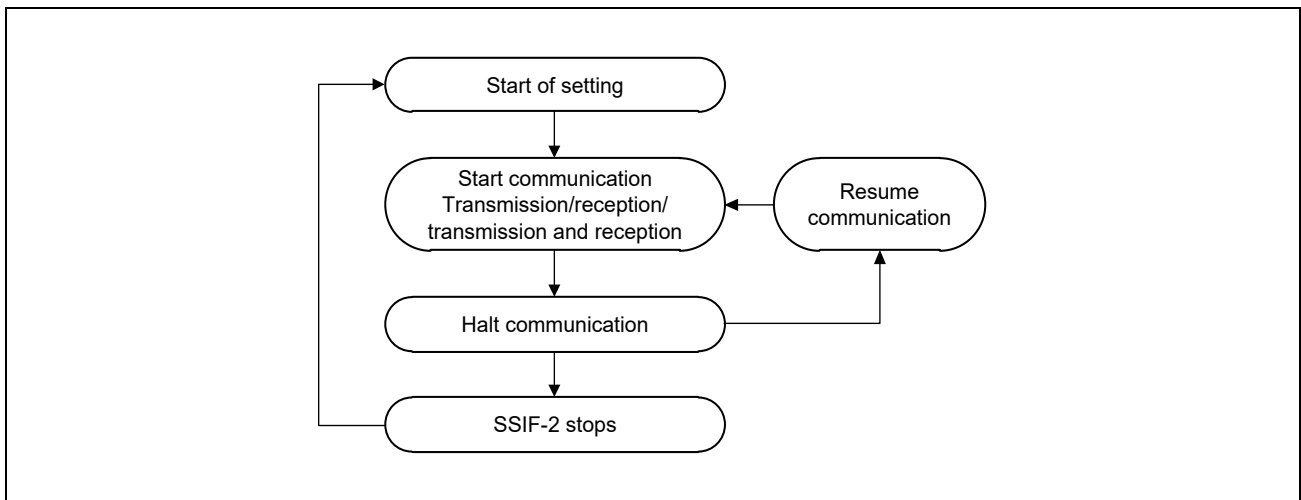

Figure 27.51 SSIF-2 Communication Operation

The procedure of each operation is described in **Section 27.5.2.1, Start Communication** to **Section 27.5.2.7, Resume Communication**.

27.5.2.1 Start Communication

This section describes how to start communication of SSIF-2. **Figure 27.52** shows the procedure to start communication. Be sure to follow the procedure. See **Section 27.5.2.2** for transmission operation and **Section 27.5.2.3** for reception operation.

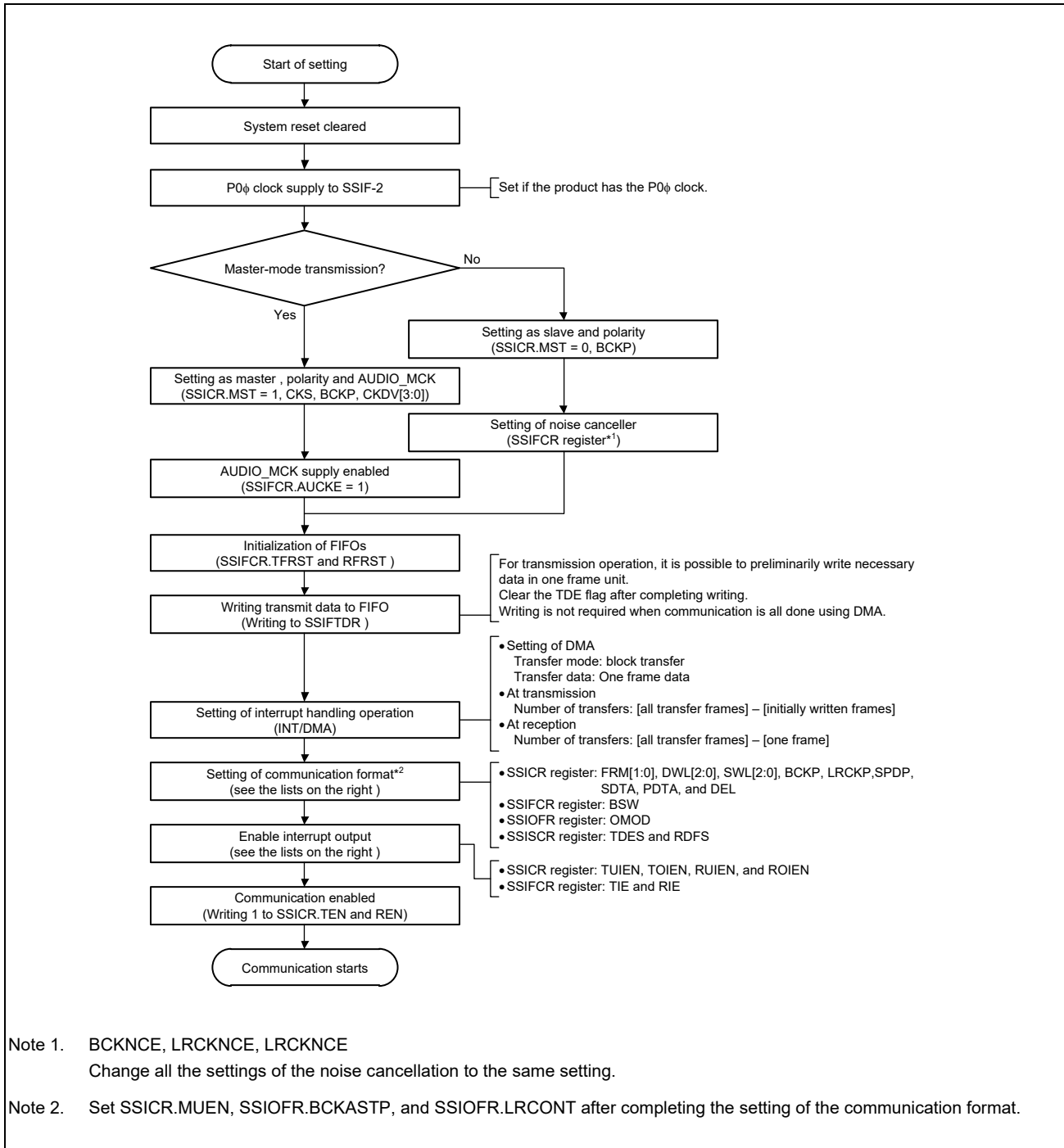

Figure 27.52 Procedure to Start Communication (CPU Procedure)

For SSIF-2 communication, continuous communication is possible with DMA interrupt handling. For transmission, write 1 to SSIFCR.TIE, SSICR.TUIEN, and SSICR.TOIEN. For reception, write 1 to SSIFCR.RIE, SSICR.RUIEN, and SSICR.ROIEN.

27.5.2.2 Transmission

Follow the transmission operation procedure (**Figure 27.53**) while the transmission is operating.

Transmission starts in synchronization with the start trigger of the SSILRCK/SSIFS signal while transmission is enabled (SSICR.TEN = 1 and SSICR.REN = 0) and while there is one or more frame of serial data in the transmit FIFO data register (SSIFTDR).

SSIF-2 outputs a transmit data empty interrupt to DMA according to the setting condition of TDE (SSISCR.TDES) and transmit data empty interrupt (SSIFCR.TIE) being enabled.

This interrupt requests writing to the transmit FIFO data register (SSIFTDR). By writing to SSIFTDR at each generation of an interrupt, serial data transmission is realized.

In the procedure to start communication, set DMA handling for transmit data empty interrupts as writing to the transmit FIFO data register (SSIFTDR). As a result, SSIF-2 is able not to mediate CPU and to transmit continuous data. When it becomes empty capacity of transmission FIFO data register set with SSISCR.TDES, transmission data empty interrupt is generated. Set the writing number of times according to empty capacity of transmission FIFO data register that transmission data empty interrupt shows. In a case of an error, stop receive procedure (**Section 27.5.2.5**) and then take the error procedure (**Section 27.5.2.6**).

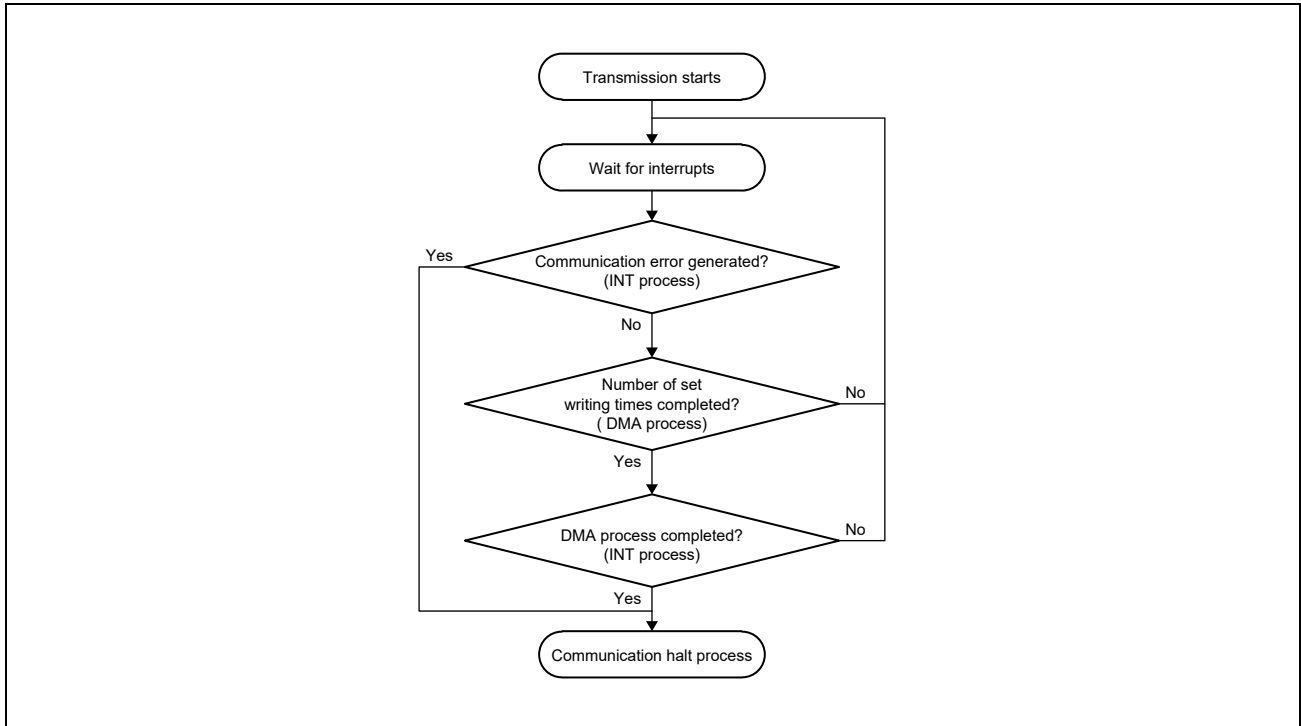

Figure 27.53 Transmission Procedure

NOTE

The communication flow defined in SSIF-2 uses the DMA. In the case the DMA is not used, observe one of SSIFSR.TDE, and write it in SSIFTDR. Follow empty capacity of transmission FIFO data register set with SSISCR.TDES about the number of times written in SSIFTDR detecting 1 of SSIFSR.TDE. After writing the transmission data corresponding to the free space to SSIFTDR, polling '1' of SSIFSR.TDE and repeating this enables continuous transmission operation.

27.5.2.3 Reception

Follow the reception operation procedure (**Figure 27.54**) while the reception is operating.

Reception starts in synchronization with the start trigger of the SSILRCK/SSIFS signal while reception is enabled (SSICR.TEN = 0 and SSICR.REN = 1). SSIF-2 outputs a receive data full interrupt to DMA according to the setting of RDF (SSISCR.RDFS) and receive data empty interrupt (SSIFCR.RIE) being enabled. This interrupt requests reading from the receive FIFO data register (SSIFRDR). By reading from SSIFRDR at each generation of an interrupt, serial data reception is realized.

In the procedure to start communication, set DMA handling for receive data full interrupts as reading from receive FIFO data register (DDIFRDR). As a result, SSIF-2 is able not to mediate CPU and to receive continuous data. If the data capacity of reception FIFO data register set with SSISCR.RDFS is stored, receive data full interrupt is generated. Set the writing number of times according to the data capacity of reception FIFO data register that receive data full interrupt shows.

In the case of an error, stop the receive operation (**Section 27.5.2.6**) and then take the error procedure (**Section 27.5.2.6**).

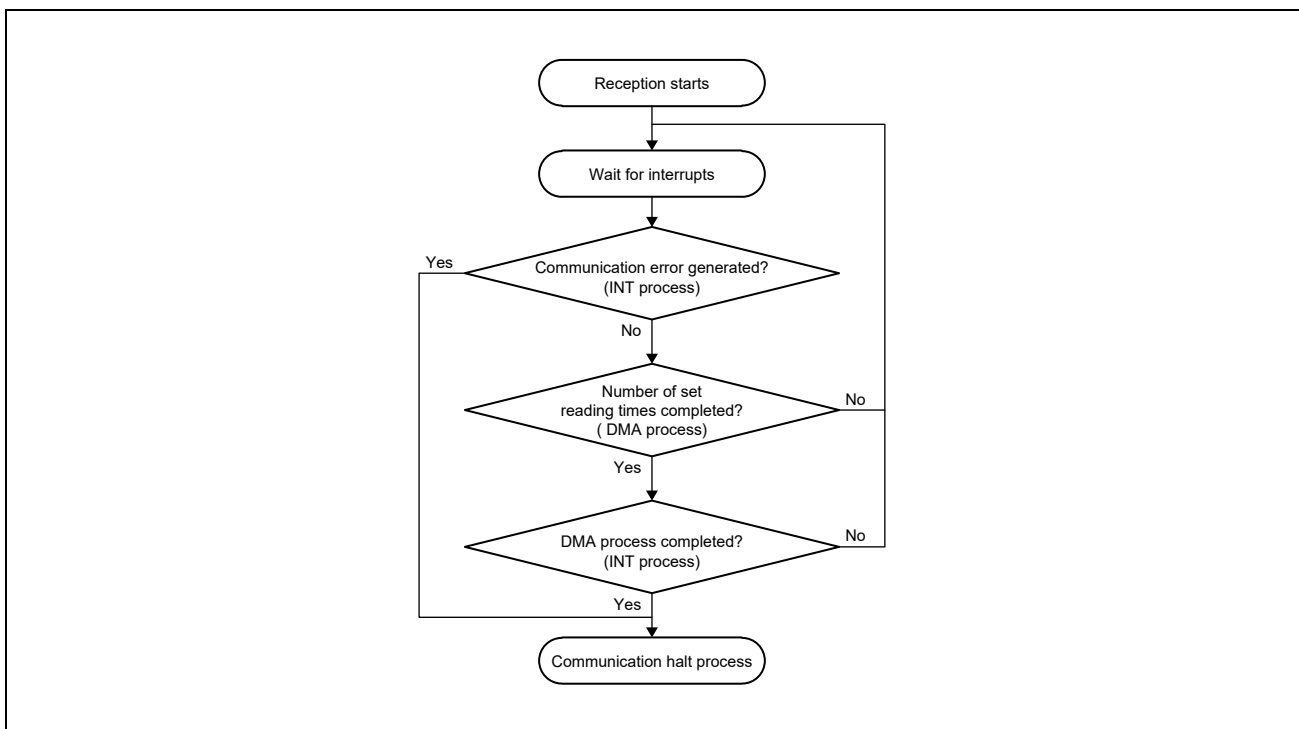

Figure 27.54 Reception Procedure

NOTE

The communication flow defined in SSIF-2 uses the DMA. In the case the DMA is not used, observe 1 of SSIFSR.RDF, and read SSIFRDR. Follow the receive data capacity of reception FIFO data register set with SSISCR.RDFS about the number of times in which SSIFRDR is read detecting 1 of SSIFSR.RDF. After reading the received data from SSIFRDR, Continuous reception operation is possible by polling '1' of SSIFSR.RDF and repeating this.

27.5.2.4 Transmission and Reception

Transmission and reception start in synchronization with the start trigger of the SSILRCK/SSIFS signal while transmission and reception are enabled (SSICR.TEN = 1 and SSICR.REN = 1) and while there is one or more frames of serial data in the transmit FIFO data register (SSIFTDR). The transmission and reception operation of SSIF-2 can be transmitted and received continuously by each doing the procedure for showing in the transmission operation (**Section 27.5.2.2**) and the reception operation (**Section 27.5.2.3**). As transmission and reception are independent in SSIF-2, see sections of transmission and reception respectively. See **Section 27.5.2.5, Halt Communication** to halt communication.

27.5.2.5 Halt Communication

This section describes how to halt communication of SSIF-2. **Figure 27.55** shows the procedure to halt communication. Be sure to follow the procedure.

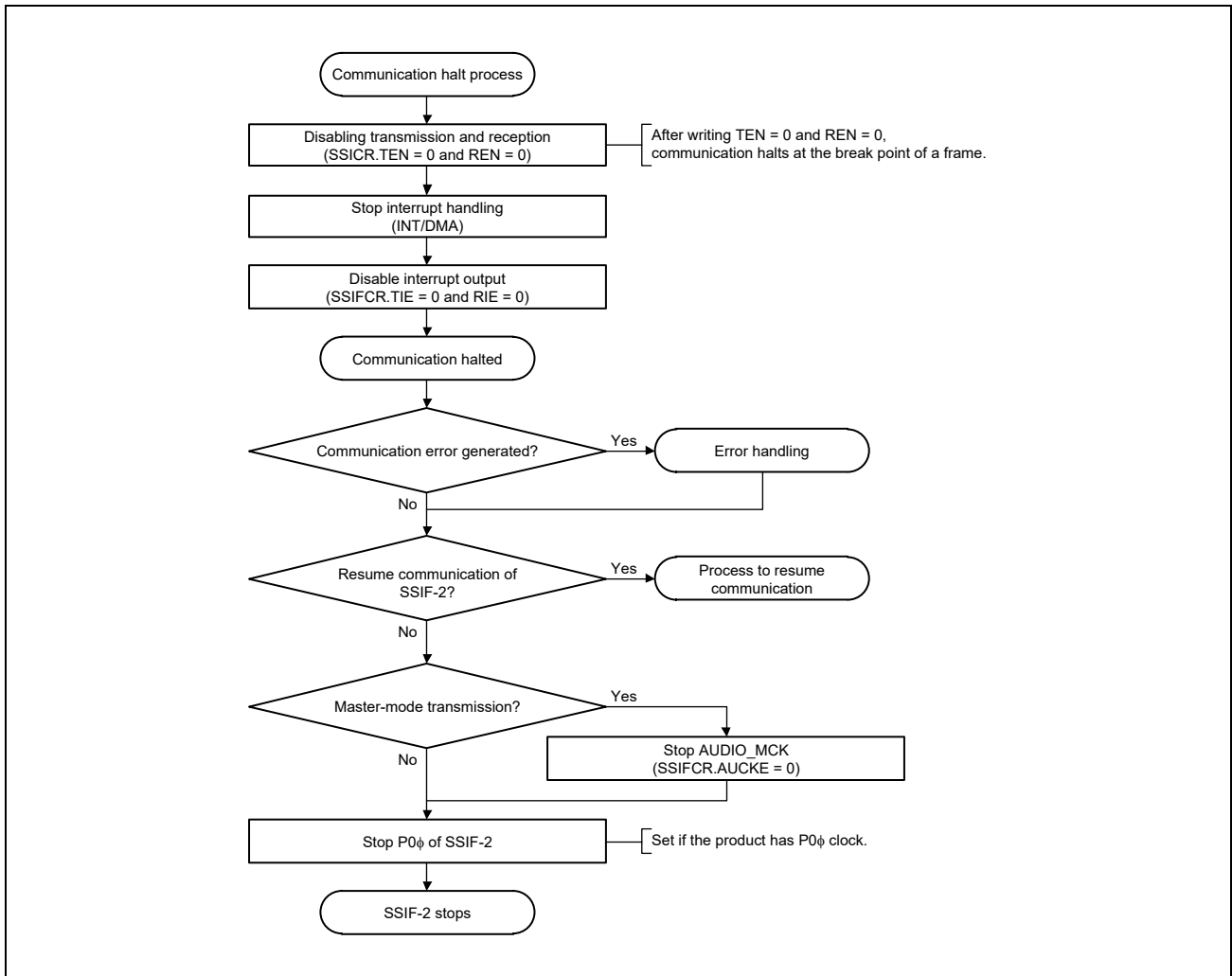

Figure 27.55 Procedure to Halt Communication (CPU Procedure)

To halt the communication of SSIF-2, supply of the following clocks are required until the SSISR.IIRQ bit indicates an idle state.

- Input clock from the SSIBCK pin when SSICR.MST = 0
- AUDIO_MCK when SSICR.MST = 1

To resume communication of SSIF-2 in the previous setting, see **Section 27.5.2.7, Resume Communication**.

NOTE

When communication of SSIF-2 is halted according to the procedure to halt communication in **Figure 27.55**, resume communication according to the procedure to start communication in **Figure 27.52**.

27.5.2.6 Error Handling

SSIF-2 has the following four errors.

- Transmit underflow error
- Transmit overflow error
- Receive underflow error
- Receive overflow error

When an underflow error or overflow error is generated, SSIF-2 need to be restarted. Take the error procedure (**Figure 27.56**) according to the procedure to halt communication (**Figure 27.55**).

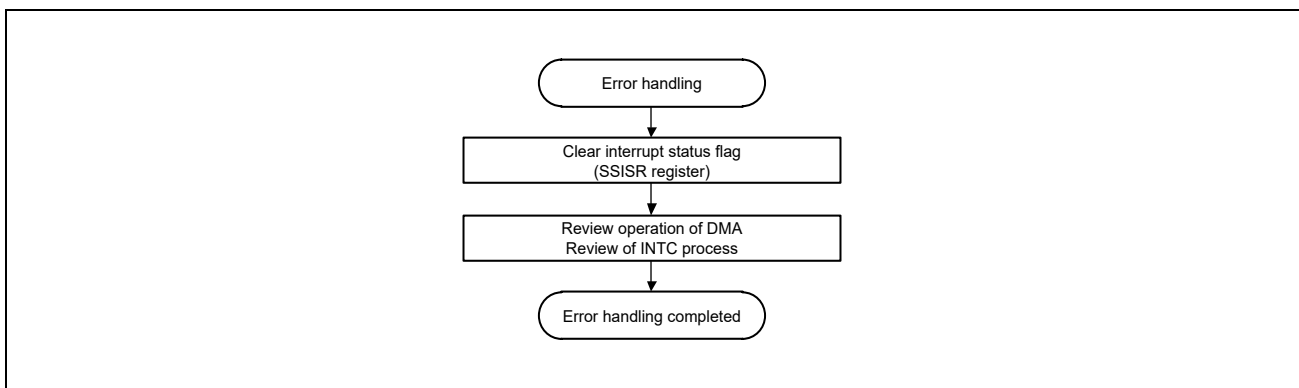

Figure 27.56 Error Handling Procedure

Four error operations are described as follows. When the interrupt output enable bit of the SSICR register is enabled and error flags are set, an error interrupt is generated. See descriptions of flags in **Section 27.4.1.2, Status Register (SSISR)** for the setting conditions of error flags.

(1) Transmit Underflow Error

In the case a transmit underflow error is generated during transmission (SSICR.TEN = 1, SSISR.IIRQ = 0), review the number of write operations to the transmit FIFO data register (SSIFTDR) according to serial data empty interrupts. After generation of a transmit underflow error, data to be transmitted from SSIF-2 are 0 output. To transmit data written to SSIFTxD pin normally, run the procedure to halt communication (**Figure 27.55**) and then take the error procedure (**Figure 27.56**). When this error is generated, serial data is consumed as usual. To resume transmission of SSIF-2, write data from the beginning of one frame.

(2) Transmit Overflow Error

In the case a transmit overflow error is generated, review the number of write operations to the transmit FIFO data register (SSIFTDR) according to transmit data empty interrupts. Data is not written to SSIFTDR where a transmit overflow error is generated. This error is generated regardless of while the transmission is operating. To resume transmission of SSIF-2, take the procedure to halt communication (**Figure 27.55**) and then take the error procedure (**Figure 27.56**). When communication is resumed, consider the lost serial data.

(3) Receive Underflow Error

In the case a receive underflow error is generated, review the number of reading operations from the receive FIFO data register (SSIFRDR) according to receive data full interrupts. The value read from SSIFRDR is undefined where a receive underflow error is generated. This error is generated regardless of while the reception is operating. To resume reception of SSIF-2, take the procedure to halt communication (**Figure 27.55**) and then take the error procedure (**Figure 27.56**).

(4) Receive Overflow Error

In the case a receive overflow error is generated during reception (SSICR.REN = 1, SSISR.IIRQ = 0), review the number of reading operations from the receive FIFO data register (SSIFRDR) according to receive data full interrupts. Data is not stored in SSIFRDR when a receive overflow error is generated. To resume reception of SSIF-2, take the procedure to halt communication (**Figure 27.55**) and then take the error handling procedure (**Figure 27.56**).

27.5.2.7 Resume Communication

To resume communication of SSIF-2, follow the procedure shown in **Figure 27.57**. After communication is halted, the same setting is applied when it is resumed. To change the settings of clocks and slave/master mode, follow the procedure to start communication (**Figure 27.52**). For communication after resume, see **Section 27.5.2.2** and **Section 27.5.2.3**.

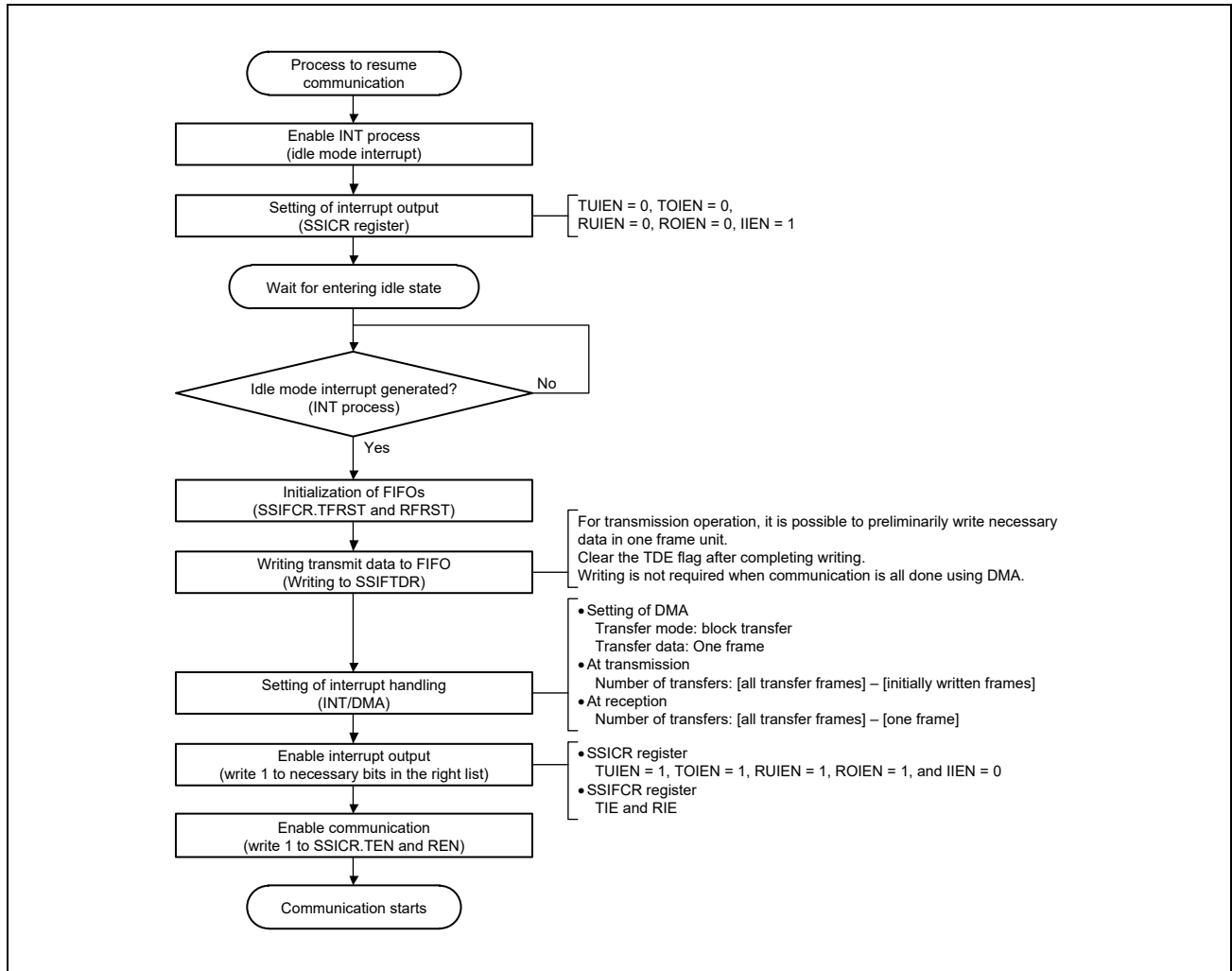

Figure 27.57 Procedure to Resume Communication (CPU Procedure)

27.5.3 Interrupt Sources

Table 27.18 lists the interrupt sources. Set enable/disable of interrupt output of each source with the TUIEN, TOIEN, RUIEN, ROIEN, and I IEN bits in the SSICR register and the TIE and RIE bits in the SSIFCR register.

Table 27.18 Interrupt Sources

Interrupt Source	Interrupt	Interrupt Flag	Interrupt Sense	DMA Activation
INT_ssif_int_req	Transmit underflow interrupt/ Transmit overflow interrupt/ Receive underflow interrupt/ Receive overflow interrupt/ Idle mode interrupt	SSISR.TUIRQ SSISR.TOIRQ SSISR.RUIRQ SSISR.ROI RQ SSISR.IIRQ	Level	Not available
INT_ssif_dma_tx	Transmit data empty interrupt	SSIFSR.TDE	Edge	Available
INT_ssif_dma_rx	Receive data full interrupt	SSIFSR.RDF	Edge	Available
INT_ssif_dma_rt	Receive data full interrupt/ Transmit data empty interrupt	SSIFSR.TDE/SSIFSR.RDF	Edge	Available

27.5.3.1 INT_ssif_int_req Interrupt

This interrupt source combines five interrupts. Enable output of necessary interrupts before using SSIF-2. This interrupt moves from the flag and the output enable permission that five factors have respectively (**Figure 27.58**). To clear an interrupt, set the interrupt enable to 0 or clear the interrupt flag to 0.

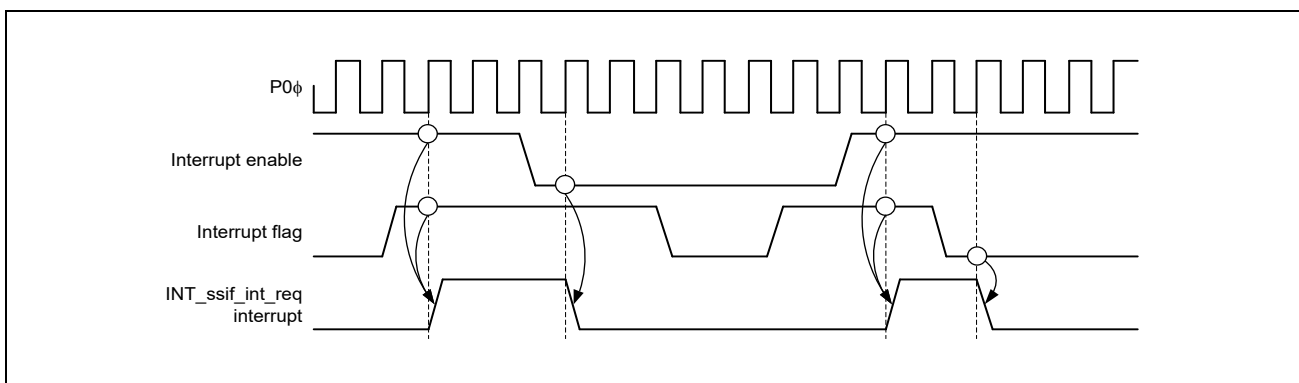

Figure 27.58 Timing Chart of the Common Interrupt Source, INT_ssif_int_req

(1) Transmit underflow interrupt

As the transmit underflow interrupt, SSISR.TUIRQ is output while SSICR.TUIEN = 1. To restart transmission (SSICR.TEN = 1), enable the output of this interrupt (SSICR.TUIRQ = 1). In the case this interrupt is generated, take the procedure to halt communication (**Figure 27.55**) and then take the error procedure (**Figure 27.56**).

(2) Transmit overflow interrupt

As the transmit overflow interrupt, SSISR.TOIRQ is output while SSICR.TOIRQ = 1. To restart transmission (SSICR.TEN = 1), enable the output of this interrupt (SSICR.TOIRQ = 1). In the case this interrupt is generated, take the procedure to halt communication (**Figure 27.55**) and then take the error procedure (**Figure 27.56**).

(3) Receive underflow interrupt

As the receive underflow interrupt, SSISR.RUIRQ is output while SSICR.RUIRQ = 1. To restart reception (SSICR.REN = 1), enable the output of this interrupt (SSICR. RUIRQ = 1). In the case this interrupt is generated, take the procedure to halt communication (**Figure 27.55**) and then take the error procedure (**Figure 27.56**).

(4) Receive overflow interrupt

As the receive overflow interrupt, SSISR.ROIRQ is output while SSICR.ROIRQ = 1. To restart reception (SSICR.REN = 1), enable the output of this interrupt (SSICR. ROIRQ = 1). In the case this interrupt is generated, take the procedure to halt communication (**Figure 27.55**) and then take the error procedure (**Figure 27.56**).

(5) Idle mode interrupt

As the idle mode interrupt, SSISR.IIRQ is output while SSICR.IIEN = 1. When the thing that the communication has stopped completely is confirmed, this interrupt is used (**Figure 27.57**).

27.5.3.2 INT_ssif_dma_tx Interrupt [full-duplex communication]

As the transmit data empty interrupt, a pulse interrupt is output by the following condition.

- SSIFSR.TDE and SSIFCR.TIE becomes 1.
 SSIF-2 operation: SSIFSR.TDE becomes 1 from 0 while SSIFCR.TIE = 1
 CPU operation: SSIFCR.TIE is changed to 1 from 0 while SSIFSR.TDE = 1

An interrupt suppression function is available for this interrupt to prevent the thing that cannot be taken. When the DMA is busy state (Interrupt cannot be accepted), and the interruption condition occurs, output of this interrupt is held. This interrupt is output after the DMA becomes acceptable (**Figure 27.59**).

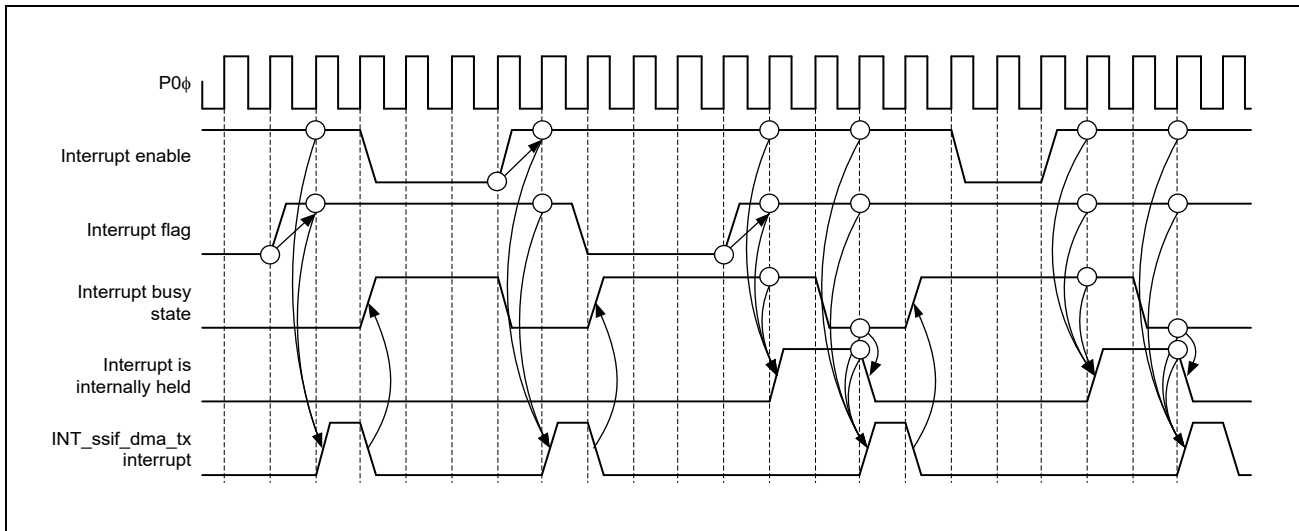

Figure 27.59 INT_ssif_dma_tx Interrupt Timing Chart

27.5.3.3 INT_ssif_dma_rx Interrupt [full-duplex communication]

As the receive data full interrupt, a pulse interrupt is output by the following condition.

- SSIFSR.RDF and SSIFCR.RIE becomes 1.
 SSIF-2 operation: SSIFSR.RDF becomes 1 from 0 while SSIFCR.RIE = 1.
 CPU operation: SSIFCR.RIE is changed to 1 from 0 while SSIFSR.RDF = 1.

An interrupt suppression function is available for this interrupt to prevent the thing that cannot be taken. When the DMA is busy state (Interrupt cannot be accepted), and the interruption condition occurs, output of this interrupt is held. This interrupt is output after the DMA becomes acceptable. It operates in the same way as in **Figure 27.59**.

27.5.3.4 INT_ssif_dma_rt Interrupt [half-duplex communication]

This interrupt is output by two sources, transmit data empty interrupt and receive data full interrupt. When this interrupt is generated, read the interrupt flag and specify the interrupt source.

An interrupt suppression function is available for this interrupt to prevent the thing that cannot be taken. When the DMA is busy state (Interrupt cannot be accepted), and the interruption condition occurs, output of this interrupt is held. This interrupt is output after the DMA becomes acceptable (**Figure 27.59**).

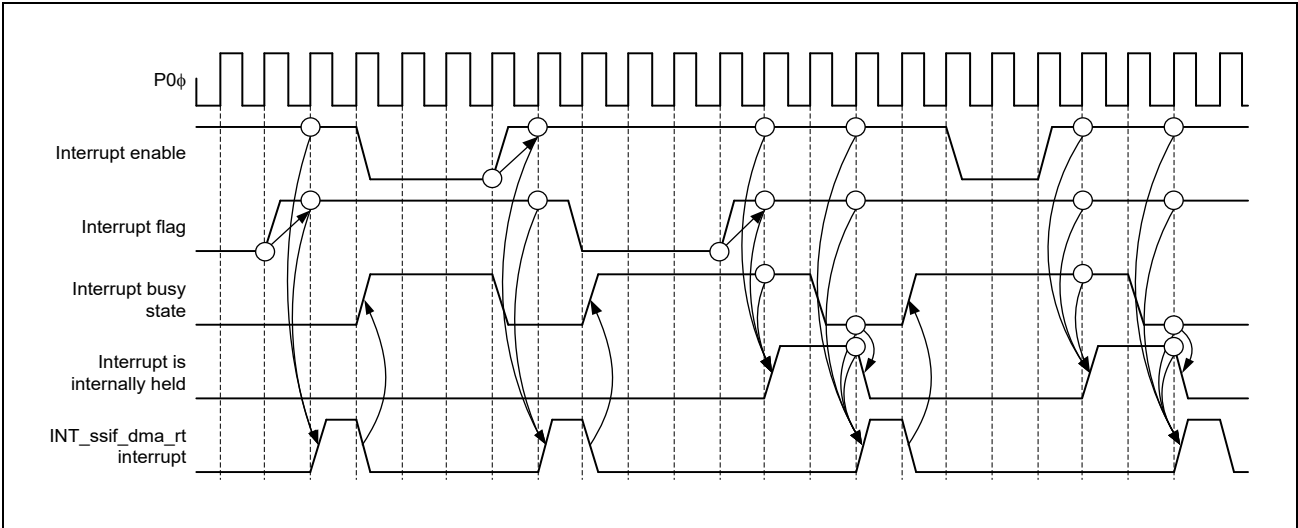

Figure 27.60 INT_ssif_dma_rt Interrupt Timing Chart

27.5.4 Software Resets

SSIF-2 has three software reset bits to reset its states.

- SSIF-2 software reset (SSIFCR.SSIRST)
- Transmit FIFO data register reset (SSICR.TFRST)
- Receive FIFO data register reset (SSIFCR.RFRST)

It explains the procedure of three software reset.

27.5.4.1 Software Reset Procedure

(1) SSIF-2 Software Reset

For the SSIF-2 software reset bit (SSIFCR.SSIRST), follow the procedure shown in **Figure 27.61**. After a reset, the same setting is applied when it is resumed. To change the settings of clocks and slave/master mode, follow the procedure to start communication (**Figure 27.52**). See **Section 27.5.2.2, Transmission** and **Section 27.5.2.3, Reception** respectively for transmission and reception after communication is resumed.

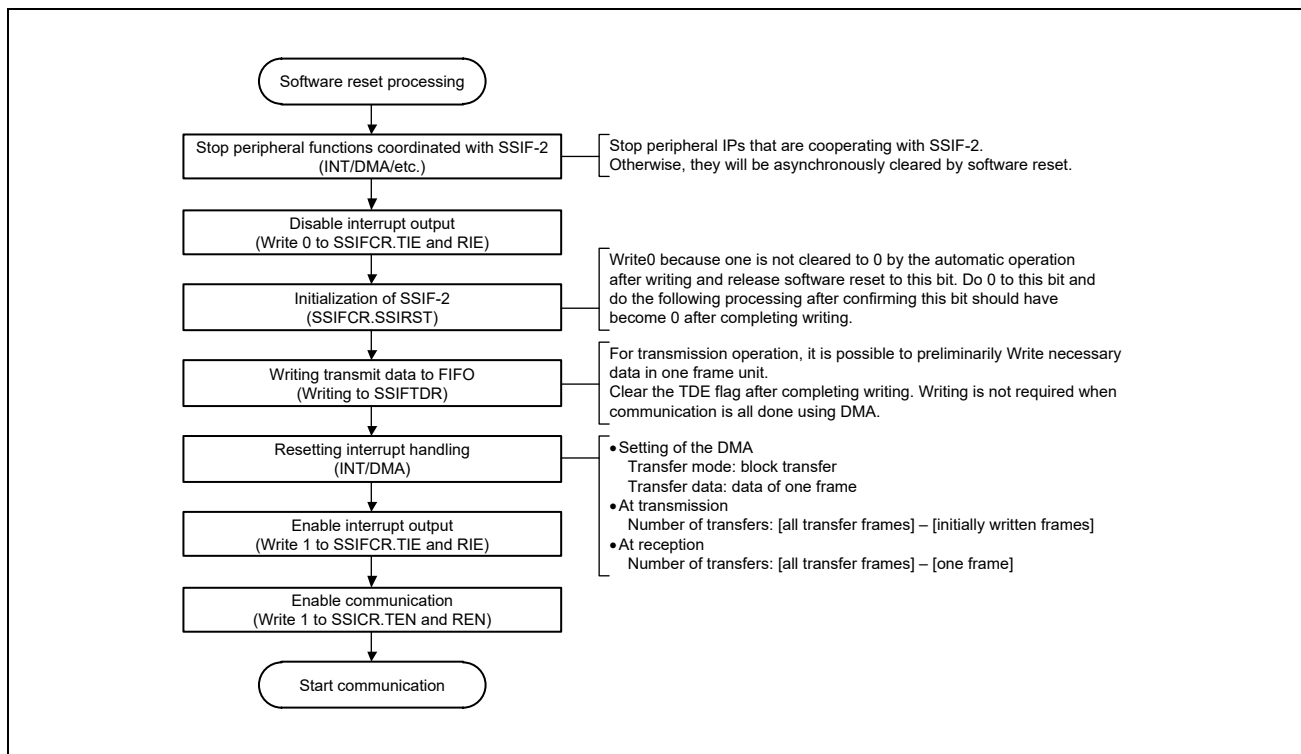

Figure 27.61 Software Reset Procedure (CPU Procedure)

(2) Transmit FIFO Data Register Reset

To initiate a transmit FIFO data register reset, follow the procedure to start communication (**Figure 27.52**) and resume communication (**Figure 27.57**).

(3) Receive FIFO Data Register Reset

To initiate a receive FIFO data register reset, follow the procedure to start communication (**Figure 27.52**) and resume communication (**Figure 27.57**).

27.6 Notes

27.6.1 Notes

27.6.1.1 Attention by communication using DMA

SSIF-2 assumes the DMA access as follows.

Table 27.19 Interrupt to expect DMA access

Communication operation	Interrupt	DMA access	LSI specification	Remarks
Transmission	INT_ssif_dma_tx	Write to SSIFTDR	Full duplex transmission	
	INT_ssif_dma_rt		Half duplex transmission	
Reception	INT_ssif_dma_rx	Read SSIFRDR	Full duplex transmission	
	INT_ssif_dma_rt		Half duplex transmission	
Transmission and Reception	INT_ssif_dma_tx	Write to SSIFTDR	Full duplex transmission	
	INT_ssif_dma_rx	Read SSIFRDR	Half duplex transmission	

27.6.1.2 Notes for Slave-mode Communication

(1) ADCKE Control

In slave-mode communication (SSICR.MST = 0), SSIF-2 needs supply of SSIBCK. To stop BCK on the master side, make sure that SSIF-2 is in the idle state (SSISR.IIRQ = 1). If BCK is stopped before SSIF-2 becomes idle, take the procedure to start communication (**Figure 27.52**) or wait for an idle state by taking the procedure to resume communication (**Figure 27.57**).

(2) SSI_RCK

SSIF-2 has the terminal SSI_RCK that shows the synchronization of the communication. Match communication format of the opposing device and SSIF-2 when SSIF-2 is slave communication (SSICR.MST=0). SSIF-2 uses the signal of SSI_RCK only as a communication start trigger.

27.6.1.3 Notes for Master-mode Communication

(1) ADCKE Control

In master-mode communication (SSICR.MST = 1), SSIF-2 operates with the audio clock (AUDIO_MCK). To stop SSIF-2 completely, make sure that SSIF-2 is in the idle state (SSISR.IIRQ = 1) and then write 0 to SSIFCR.ADCKE. If 0 is written to SSIFCR.ADCKE before SSIF-2 becomes idle, take the procedure to start communication (**Figure 27.52**).

(2) LRCONT Control

To stop the output to the SSI_RCK pin with SSIOFR.LRCONT when SSIF-2 is in the idle state in master-mode communication (SSICR.MST = 1), note the following: The output stops when 0 is written from 1 to SSIOFR.LRCONT. (**Figure 27.43**). Make sure that the remote device is not affected.

(3) BCKASTP Control

To stop the output to the SSIBCK pin with SSIOFR.BCKASTP in master-mode communication (SSICR.MST = 1) and while SSIF-2 is in the idle state, note the following; By writing 0 to SSIOFR.BCKASTP while it is 1, the output stops immediately (**Figure 27.44**). So, make sure that the remote device is not affected.

NOTE

When the opposing device who is the slave needs the clock of the terminal SSI_BCK before the communication operates, it is not possible to use it.

27.6.1.4 Notes for Communication Flow

(1) When an Error Interrupt is Generated

SSIF-2 has the following four errors.

- Transmit underflow error
- Transmit overflow error
- Receive underflow error
- Receive overflow error

When an underflow error or overflow error is generated, SSIF-2 need to be restarted. Take the error procedure (**Figure 27.56**) according to the procedure to halt communication (**Figure 27.55**).

(a) Transmit Underflow Error

In the case a transmit underflow error is generated during transmission (SSICR.TEN = 1, SSISR.IIRQ = 0), review the number of write operations to the transmit FIFO data register (SSIFTDR) according to serial data empty interrupts. After generation of a transmit underflow error, data to be transmitted from SSIF-2 are 0 output. To transmit data written to SSIFTxD pin normally, run the procedure to halt communication (**Figure 27.55**) and then take the error procedure (**Figure 27.56**). When this error is generated, serial data is consumed as usual. To resume transmission of SSIF-2, write data from the beginning of one frame.

(b) Transmit Overflow Error

In the case a transmit overflow error is generated, review the number of write operations to the transmit FIFO data register (SSIFTDR) according to transmit data empty interrupts. Data is not written to SSIFTDR where a transmit

overflow error is generated. This error is generated regardless of while the transmission is operating. To resume transmission of SSIF-2, take the procedure to halt communication (**Figure 27.55**) and then take the error procedure (**Figure 27.56**). When communication is resumed, consider the lost serial data.

(c) Receive Underflow Error

In the case a receive underflow error is generated, review the number of reading operations from the receive FIFO data register (SSIFRDR) according to receive data full interrupts. The value read from SSIFRDR is undefined where a receive underflow error is generated. This error is generated regardless of while the reception is operating. To resume reception of SSIF-2, take the procedure to halt communication (**Figure 27.55**) and then take the error procedure (**Figure 27.56**).

(d) Receive Overflow Error

In the case a receive overflow error is generated during reception (SSICR.REN = 1, SSISR.IIRQ = 0), review the number of reading operations from the receive FIFO data register (SSIFRDR) according to receive data full interrupts. Data is not stored in SSIFRDR when a receive overflow error is generated. To resume reception of SSIF-2, take the procedure to halt communication (**Figure 27.55**) and then take the error handling procedure (**Figure 27.56**).

(2) Transmit Data Empty Interrupt

The communication flow defined in SSIF-2 uses the DMA. In the case the DMA is not used, observe one of SSIFSR.TDE, and write it in SSIFTDR. Follow empty capacity of transmission FIFO data register set with SSISCR.TDES about the number of times written in SSIFTDR detecting 1 of SSIFSR.TDE. Clear the transmission data that corresponds to empty capacity and clear the SSIFSR.TDE flag to SSIFTDR after writing. Transmission operation consecutive by the repeated thing is possible. SSIFSR.TDE is not cleared when not clearing.

(3) Receive Data Full Interrupt

The communication flow defined in SSIF-2 uses the DMA. In the case the DMA is not used, observe 1 of SSIFSR.RDF, and read SSIFRDR. Follow the receive data capacity of reception FIFO data register set with SSISCR.RDFS about the number of times in which SSIFRDR is read detecting 1 of SSIFSR.RDF. Clear data that does the reception completion and clear the SSIFSR.RDF flag from SSIFRDR after reading. Reception operation consecutive by the repeated thing is possible. SSIFSR.RDF is not cleared when not clearing.

(4) Switching Transfer Modes

1. For state transition from transmission, reception, and transmission and reception, disable transmission and reception (SSICR.TEN = 0, SSICR.REN = 0).
2. Confirm it is in the idle state (SSISR.IIRQ = 1).
3. In the idle state, set the SSICR.TEN bit and the SSICR.REN bit again and resume transfer.

(5) Resume Communication after Halting SSIF-2

When communication of SSIF-2 is halted according to the procedure to halt communication in **Figure 27.55**, resume communication according to the procedure to resume communication in **Figure 27.52**.

27.6.1.5 Write Access Restriction

(1) SSICR Register

If the TEN bit or REN bit is rewritten, make sure that the SSISR.IIRQ bit is in the desired status. If written, the operation performed immediately after writing is not guaranteed. For example, after enabling operation, make sure that SSISR.IIRQ = 0 and after disabling operation, make sure that SSISR.IIRQ = 1.

(a) TEN Bit and REN Bit

Writing 1 to these bits, transmission starts in synchronization with start trigger. Refer to **Section 27.5.2.2, Transmission, Section 27.5.2.3, Reception**, and **Section 27.5.2.4, Transmission and Reception** for details. Writing 0 to these bits, transmission stops in synchronization with next frame boundary. Set 1 at the same time when you use SSIF-2 as transmission and reception. To stop communication, make sure to stop transmission and reception (TEN = 0 and REN = 0).

(2) SSICR Register

(a) Clear operation of TUIRQ and TOIRQ

After the communication is permitted (SSICR.TEN is written and '1' is written from '0'), the transmission error flag (TOIRQ and TUIRQ of the SSISR register) is cleared. However, when the SSISR register is continuously read, the clearness of the transmission error flag might not be able to be read.

(b) Clear operation of RUIRQ and ROIRQ

After the communication is permitted (SSICR.REN is written and '1' is written from '0'), the transmission error flag (ROIRQ and RUIRQ of the SSISR register) is cleared. However, when the SSISR register is continuously read, the clearness of the reception error flag might not be able to be read.

(3) Communication State

Writing to the bits with shaded area in **Table 27.20** is prohibited. If written, the operation performed immediately after writing is not guaranteed.

Table 27.20 Bits Protected from Writing during Communication

Symbol	Address (Base+)		+0								+1							
			31	30	29	28	27	26	25	24	23	22	21	20	19	18	17	16
			15	14	13	12	11	10	9	8	7	6	5	4	3	2	1	0
SSICR	H'00	+0	—	CKS	TUIEN	TOIEN	RUIEN	ROIEN	IEN	—	FRM[1:0]			DWL[2:0]		SWL[2:0]		
		+2	—	MST	BCKP	LRCKP	SPDP	SDTA	PDTA	DEL	CKDV[3:0]			MUEN	—	TEN	REN	
SSISR	H'04	+0	—	—	TUIRQ	TOIRQ	RUIRQ	ROI RQ	IIRQ	—	—	—	—	—	—	—	—	
		+2	—	—	—	—	—	—	—	—	—	—	—	—	—	—	—	
SSIFCR	H'10	+0	AUCKE	—	—	—	—	—	—	—	—	—	—	—	—	—	SSIR T	
		+2	—	—	—	—	BSW	BCKN CE	LRCKN CE	RxDNC E	—	—	—	—	TIE	RIE	TFRST	RFRST
SSIFSR	H'14	+0	—	—	TDC[5:0]					—	—	—	—	—	—	—	TDE	
		+2	—	—	RDC[5:0]					—	—	—	—	—	—	—	RDF	
SSIFTDR	H'18	+0	FTDR[31:16]															
		+2	FTDR[15:0]															
SSIFRDR	H'1C	+0	FRDR[31:16]															
		+2	FRDR[15:0]															
SSIOFR		+0	—	—	—	—	—	—	—	—	—	—	—	—	—	—	—	—
		+2	—	—	—	—	—	—	BCKAS TP	LRCON T	—	—	—	—	—	—	OMOD[1:0]	
SSISCR	H'24	+0	—	—	—	—	—	—	—	—	—	—	—	—	—	—	—	—
		+2	—	—	TDES[5:0]					—	—	RDFS[5:0]						

28. CANFD Interface (RS-CANFD)

This section contains a generic description of the CANFD interface (RS-CANFD).

The first part of this section describes all this LSI specific properties, such as the number of units, register base addresses, etc. The remainder of the section describes the functions and registers of RS-CANFD.

28.1 Features of RS-CANFD

28.1.1 Number of Units and Channels

This product has the following number of RS-CANFD units.

Table 28.1 Number of Units

RS-CANFD	
Number of Units	1
Name	RSCFD0

This product has the CANFD interface channel listed below.

Table 28.2 Unit Configurations and Channels

RS-CANFD	
Number of Channels	2
Name	CAN0, CAN1

The RS-CANFD has two interface modes (classical CAN mode and CANFD mode) and uses different registers for each mode. There are two types of register names RSCANnXXX and RSCFDnCFDXXX (XXX: arbitrary) depending on interface modes. When explaining specifications common to two registers, register names are described as RSCFDn(CFD)XXX.

Table 28.3 Index

Index	Meaning
n	Throughout this section, the individual RS-CANFD units are generically indicated by the index "n" (n = 0); for example, RSCFDn(CFD)GCTR is the global control register of the RSCFDn unit.
m	Throughout this section, the individual channels of RS-CANFD units are generically indicated by the index "m" (m = 0, 1); for example, RSCFDn(CFD)CmSTS is the channel m status register.
j	The individual registers associated with receive rule table are generically indicated by the index "j" (j = 0 to 15); for example, RSCFDn(CFD)GAFLIDj is the receive rule ID register.
k	The individual transmit/receive FIFO buffers are generically indicated by the index "k" (k = 0 to 5); for example, RSCFDn(CFD)CFCK is the transmit/receive FIFO buffer configuration/control register.
x	The individual receive FIFO buffers are generically identified by the index "x" (x = 0 to 7); for example, RSCFDn(CFD)RFSTx is the receive FIFO buffer status register.
d	Data field registers of transmit/receive FIFO buffers and receive FIFO buffers are identified by "d" (classical CAN mode: d = 0, 1, CANFD mode: d = 0 to 15). For example, the transmit/receive FIFO buffer data field register is described as RSCFDn(CFD)CFDFd_k.
q	The individual receive buffers are generically indicated by the index "q" (q = 0 to 31); for example, RSCFDn(CFD)RMIDq is the receive buffer ID register.
p	The individual transmit buffers are generically indicated by the index "p" (p = 0 to 31); for example, RSCFDn(CFD)TMCp is the transmit buffer control register.
b	Data field registers of receive buffers and transmit buffers are identified by "b" (classical CAN mode: b = 0, 1, CANFD mode: b = 0 to 4). For example, the receive buffer data field register is described as RSCFDn(CFD)RMDFb_q.
r	The individual RAM tests for CAN are generically indicated by the index "r" (r = 0 to 63); for example, RSCFDn(CFD)RPGACCr is the RAM test page access register.
y	The registers not covered above are indicated by the letter "y" (y = 0); for example, RSCFDn(CFD)RMNDy is a receive buffer new data register.

Note: The functions and descriptions of registers in this section are for the RS-CANFDs that has 2 channels (m = 0, 1). When referring to information with indexes, regard the index values as the ones corresponding to your target product. Also, note that, if the value of an index exceeds the range described in this section due to your target product, write the value after reset when writing to bits outside the index range.

28.1.2 Register Base Address

RSCFDn base addresses are listed in the following table.

RSCFDn register addresses are given as offsets from the base addresses in general.

Table 28.4 Register Base Address

Base Address Name	Base Address
<RSCFD0_base>	H'0_1005_0000 (AX45MP Address Space)

28.1.3 Clock Supply

The RSCFDn clock supply is shown in the following table.

Table 28.5 Clock Supply

Unit Name	Clock for the Unit	Supply Clock Name
RSCFDn	clk_xincan	CAN_CLK
	clkc	P0φ/2
	pclk	P0φ

The operating frequency of the RSCFDn depends on the transfer rate and the number of channels in use. **Table 28.6** shows the range of the frequency.

Table 28.6 Range of Operating Frequency Depending on the Transfer Rate and the Number of Channels in Use in this LSI

Condition			Range of Operating Frequency		
Mode	Transfer Rate	No. of Channels in Use	pclk	clk_xincan* ¹	clkc* ¹ * ²
CANFD	4 Mbps	2ch	pclk ≥ 64 MHz	32 MHz	32MHz
		1ch			
	2 Mbps	2ch	pclk ≥ 32 MHz	16 MHz ≤ clk_xincan ≤ pclk/2	16 MHz ≤ clkc ≤ pclk/2
		1ch			
CAN/CANFD	1 Mbps	2ch	pclk ≥ 30.6 MHz	8 MHz ≤ clk_xincan ≤ pclk/2	8 MHz ≤ clkc ≤ pclk/2
		1ch	pclk ≥ 27.5 MHz		
	500 kbps	2ch	pclk ≥ 27.5 MHz	4 MHz ≤ clk_xincan ≤ pclk/2	4 MHz ≤ clkc ≤ pclk/2
		1ch			
	125 kbps	2ch	pclk ≥ 27.5 MHz	1 MHz ≤ clk_xincan ≤ pclk/2	1 MHz ≤ clkc ≤ pclk/2
		1ch			

Note 1. Setting the DCS bit in the RSCFDn(CFD)GCFG register enables to select either clk_xincan or clkc. Set clocks less than or equal to pclk/2. CAN clock source uses external clock.

Note 2. When pclk < 25 MHz, select clk_xincan.

28.1.4 Interrupt Request

RSCFDn interrupt requests are listed in the following table.

Table 28.7 Interrupt Requests

Unit	Interrupt Signal	Outline
	INTRCANGERR	CAN global error interrupt
	INTRCANGRECC	CAN receive FIFO interrupt
CAN0	INTRCAN0ERR	CAN0 error interrupt
	INTRCAN0REC	CAN0 transmit/receive FIFO receive completion interrupt
	INTRCAN0TRX	CAN0 transmit interrupt
CAN1	INTRCAN1ERR	CAN1 error interrupt
	INTRCAN1REC	CAN1 transmit/receive FIFO receive completion interrupt
	INTRCAN1TRX	CAN1 transmit interrupt

28.1.5 External Input/Output Signals

External input/output signals of RSCFDn are listed below.

Table 28.8 External Input/Output Signals

Unit Signal Name	Outline	Alternative Port Pin Signal
CANm_RX (m = 0, 1)	CANm receive data input	CANm_RX (m = 0, 1)
CANm_TX (m = 0, 1)	CANm transmit data output	CANm_TX (m = 0, 1)
CANm_RX_DATARATE_EN (m = 0, 1)	CANm receive data phase output	CANm_RX_DATARATE_EN (m = 0, 1)
CANm_TX_DATARATE_EN (m = 0, 1)	CANm transmit data phase output	CANm_TX_DATARATE_EN (m = 0, 1)
CAN_CLK	Clock source for CAN communication	CAN_CLK

28.2 Overview

28.2.1 Functional Overview

Table 28.9 shows the RS-CANFD module specifications. **Figure 28.1** shows the RS-CANFD module block diagram.

Table 28.9 RS-CANFD Module Specifications (1/3)

Item	Specification
Number of channels	2
Protocol	ISO11898-1 compliant Using CANFD frames is selectable by switching interface modes.
Communication speed	<p>Classical CAN mode:</p> <ul style="list-style-type: none"> Maximum 1 Mbps $\text{Communication speed (CANm bit time clock)} = \frac{1}{\text{CANm bit time}}$ $\text{CANm bit time} = \text{CANmTq} \times \text{Tq count per bit}$ $\text{CANmTq} = \frac{(\text{BRP}[9:0] \text{ bits in the RSCANn CmCFG register} + 1)}{f_{\text{CAN}}}$ $\text{CANm bit time} = \text{CANmTq} \times \text{Tq count per bit}$ <p>fCAN: Frequency of CAN clock (selected by the DCS bit in the RSCANnGCFG register)</p> <p>CANFD mode:</p> <ul style="list-style-type: none"> Nominal bit rate: max.1 Mbps, data bit rate: max. 4 Mbps $\text{Transmission rate (CANm nominal bit time clock)} = \frac{1}{\text{CANm nominal bit time}}$ $\text{Transmission rate (CANm data bit time clock)} = \frac{1}{\text{CANm data bit time}}$ $\text{CANm nominal bit time} = \text{CANmTq(N)} \times \text{Tq count per nominal bit}$ $\text{CANm data bit time} = \text{CANmTq(D)} \times \text{Tq count per data bit}$ $\text{CANmTq(N)} = \frac{(\text{NBRP}[9:0] \text{ bits in the RSCFDnCFDCmNCFG register} + 1)}{f_{\text{CAN}}}$ $\text{CANmTq(D)} = \frac{(\text{DBRP}[7:0] \text{ bits in the RSCFDnCFDCmDCFG register} + 1)}{f_{\text{CAN}}}$ <p>fCAN: Frequency of CAN clock (selected by the DCS bit in the RSCFDnCFDGCFCFG register)</p> <p>m = 0, 1 Tq: Time quantum</p>
Buffer	<p>160 buffers in total</p> <ul style="list-style-type: none"> Individual buffers: 32 buffers (16 buffers × 2 channels) Transmit buffer: 16 buffers per channel Transmit queue: Single queue per channel (shared with the transmit buffer; up to 16 buffers allocatable) Shared buffers: 128 buffers for all channels Receive buffer: 0 to 32 buffers Receive FIFO buffer: 8 FIFO buffers (up to 128 buffers allocatable to each) Transmit/receive FIFO buffer: 3 FIFO buffers per channel (up to 128 buffers allocatable to each)
Reception function	<ul style="list-style-type: none"> Receives data frames and remote frames. Selects ID format (standard ID, extended ID, or both IDs) to be received. Sets interrupt enable/disable for each FIFO. Mirror function (reception of messages transmitted from the own CAN node) Timestamp function (to record message reception time as a 16-bit timer value)

Table 28.9 RS-CANFD Module Specifications (2/3)

Item	Specification
Reception filter function	<ul style="list-style-type: none"> • Selects receive messages according to 128 receive rules. • Sets the number of receive rules (0 to 128) for each channel. • Acceptance filter processing: Sets ID and mask for each receive rule. • DLC filter processing: Enables DLC filter check for each acceptance rule.
Receive message transfer function	<ul style="list-style-type: none"> • Routing function Transfers receive messages to arbitrary destinations (can be transferred to up to 8 buffers) Transfer destination: Receive buffer, receive FIFO buffer, and/or transmit/receive FIFO buffer • Label addition function Stores label information together with a message in a receive buffer and FIFO buffer.
Transmission function	<ul style="list-style-type: none"> • Transmits data frames and remote frames. • Selects ID format (standard ID, extended ID, or both IDs) to be transmitted. • Sets interrupt enable/disable for each transmit buffer and transmit/receive FIFO buffer. • Selects ID priority transmission or transmit buffer number priority transmission. • Transmit request can be aborted (possible to confirm with a flag) • One-shot transmission function
Interval transmission function	Transmit messages at configurable intervals (transmit mode or gateway mode of transmit/receive FIFO buffers)
Transmit queue function	Transmits all stored messages according to the ID priority.
Transmit history function	Stores the history information of transmission-completed messages Adds timestamp (recording message transmission time as a 16-bit timer value) to the history information.
Gateway function	Transmits a received message automatically.
Bus off recovery mode selection	Selects the method for returning from bus off state. <ul style="list-style-type: none"> • ISO11898-1 compliant • Automatic entry to channel halt mode at bus-off entry • Automatic entry to channel halt mode at bus-off end • Transition to channel halt mode by program request • Transition to the error-active state by program request (forcible return from the bus off state)
Error status monitoring	<ul style="list-style-type: none"> • Monitors CAN protocol errors (stuff error, form error, ACK error, CRC error, bit error, ACK delimiter error, and bus dominant lock). • Detects error status transitions (error warning, error passive, bus off entry, and bus off recovery) • Reads the error counter. • Monitors DLC errors.
Interrupt source	8 sources <ul style="list-style-type: none"> • Global Interrupts (2 sources) <ul style="list-style-type: none"> Receive FIFO interrupt Global error interrupt • Channel interrupts (3 sources/channel) <ul style="list-style-type: none"> CANm transmit interrupt (m = 0, 1) <ul style="list-style-type: none"> – CANm transmit complete interrupt – CANm transmit abort interrupt – CANm transmit/receive FIFO transmit complete interrupt (in transmit mode, gateway mode) – CANm transmit history interrupt – CANm transmit queue interrupt CANm transmit/receive FIFO receive complete interrupt (in receive mode, gateway mode) CANm error interrupt
CAN stop mode	Reduces power consumption by stopping clock supply to the RS-CANFD module.
CAN clock source	Selects the clk or the clk_xincan. As for the range of operating frequency, see Table 28.6 .

Table 28.9 RS-CANFD Module Specifications (3/3)

Item	Specification
Test function	Test function for user evaluation <ul style="list-style-type: none">• Listen-only mode• Self-test mode 0 (external loopback)• Self-test mode 1 (internal loopback)• Restricted operation mode• RAM test (read/write test)• Inter-channel communication test [CRC error test enabled]

28.2.2 Interface Modes

The RS-CANFD has two interface modes.

- Classical CAN mode: Handles only classical CAN frames.
- CANFD mode: Handles classical CAN frames and CANFD frames.

These two modes use different register maps with the same base address. Register maps change by switching interface modes.

Interface modes are switched by the RCMC bit in the RSCFDn(CFD)GRMCFG register.

28.2.3 Block Diagram

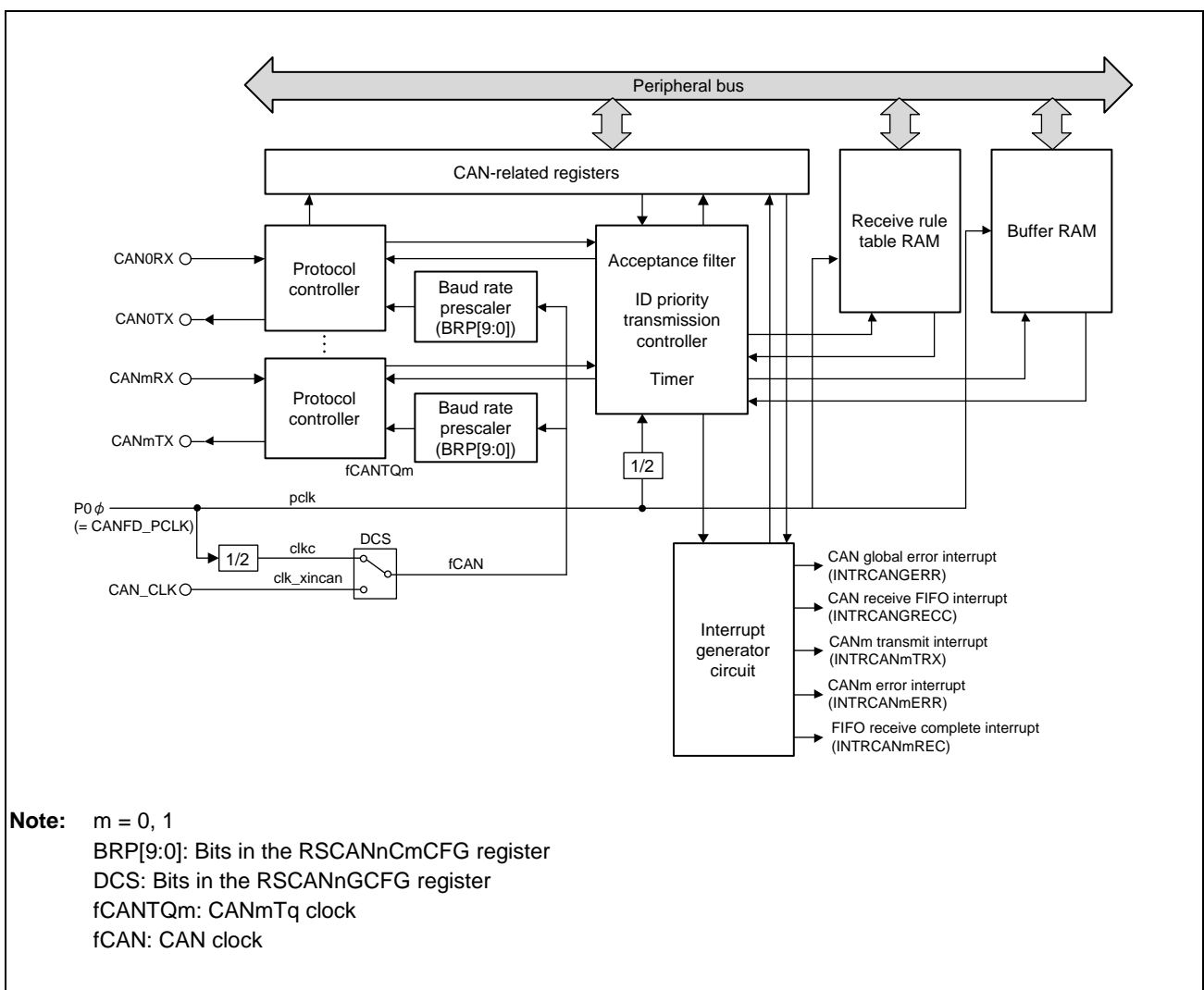

Figure 28.1 RS-CANFD Module Block Diagram (Classical CAN Mode)

In CANFD mode, different clock signals are input to the baud rate prescaler and the protocol controller respectively. See **Section 28.11.1.3, Communication Speed Setting**.

28.3 Registers (Classical CAN Mode)

28.3.1 List of Registers

The following tables list RS-CANFD registers to be used in classical CAN mode. For details about <RSCFDn_base>, see **Section 28.1.2, Register Base Address**.

For registers initialized in global reset mode and channel reset mode, refer to the following.

- **Table 28.37, Registers Initialized in Global Reset Mode or Channel Reset Mode**
- **Table 28.38, Registers Initialized Only in Global Reset Mode**

Table 28.10 Registers (1/3)

Module	Register	Symbol	Address
Interface mode-related registers			
RSCANn	Global interface mode select register	RSCANnGRMCFG	<RSCFDn_base> + H'04FC
Channel-related registers			
RSCANn	Channel m Configuration Register	RSCANnCmCFG	<RSCFDn_base> + H'0000 + (H'10 × m)
RSCANn	Channel m control register	RSCANnCmCTR	<RSCFDn_base> + H'0004 + (H'10 × m)
RSCANn	Channel m status register	RSCANnCmSTS	<RSCFDn_base> + H'0008 + (H'10 × m)
RSCANn	Channel m error flag register	RSCANnCmERFL	<RSCFDn_base> + H'000C + (H'10 × m)
Global-related registers			
RSCANn	Global configuration register	RSCANnGCFG	<RSCFDn_base> + H'0084
RSCANn	Global control register	RSCANnGCTR	<RSCFDn_base> + H'0088
RSCANn	Global status register	RSCANnGSTS	<RSCFDn_base> + H'008C
RSCANn	Global error flag register	RSCANnGERFL	<RSCFDn_base> + H'0090
RSCANn	Global timestamp counter register	RSCANnGTSC	<RSCFDn_base> + H'0094
RSCANn	Global TX Interrupt Status Register 0	RSCANnGTINTSTS0	<RSCFDn_base> + H'0460
RSCANn	Global FD Configuration Register	RSCANnGFDCFG	<RSCFDn_base> + H'0474
Receive rule-related registers			
RSCANn	Receive Rule Entry Control Register	RSCANnGAFLECTR	<RSCFDn_base> + H'0098
RSCANn	Receive Rule Configuration Register 0	RSCANnGAFLCFG0	<RSCFDn_base> + H'009C
RSCANn	Receive Rule ID Register j	RSCANnGAFLIDj	<RSCFDn_base> + H'0500 + (H'10 × j)
RSCANn	Receive Rule Mask Register j	RSCANnGAFLMj	<RSCFDn_base> + H'0504 + (H'10 × j)
RSCANn	Receive Rule Pointer 0 Register j	RSCANnGAFLP0_j	<RSCFDn_base> + H'0508 + (H'10 × j)
RSCANn	Receive Rule Pointer 1 Register j	RSCANnGAFLP1_j	<RSCFDn_base> + H'050C + (H'10 × j)
Receive buffer-related registers			
RSCANn	Receive Buffer Number Register	RSCANnRMNB	<RSCFDn_base> + H'00A4
RSCANn	Receive Buffer New Data Register y	RSCANnRMNDy	<RSCFDn_base> + H'00A8 + (H'04 × y)
RSCANn	Receive Buffer ID Register q	RSCANnRMIDq	<RSCFDn_base> + H'0600 + (H'10 × q)
RSCANn	Receive Buffer Pointer Register q	RSCANnRMPTRq	<RSCFDn_base> + H'0604 + (H'10 × q)
RSCANn	Receive Buffer Data Field 0 Register q	RSCANnRMDf0_q	<RSCFDn_base> + H'0608 + (H'10 × q)
RSCANn	Receive Buffer Data Field 1 Register q	RSCANnRMDf1_q	<RSCFDn_base> + H'060C + (H'10 × q)

Table 28.10 Registers (2/3)

Module	Register	Symbol	Address
Receive FIFO buffer-related registers			
RSCANn	Receive FIFO Buffer Configuration and Control Register x	RSCANnRFCCx	<RSCFDn_base> + H'00B8 + (H'04 × x)
RSCANn	Receive FIFO Buffer Status Register x	RSCANnRFSTSx	<RSCFDn_base> + H'00D8 + (H'04 × x)
RSCANn	Receive FIFO Buffer Pointer Control Register x	RSCANnRFPCRx	<RSCFDn_base> + H'00F8 + (H'04 × x)
RSCANn	Receive FIFO Buffer Access ID Register x	RSCANnRFIDx	<RSCFDn_base> + H'0E00 + (H'10 × x)
RSCANn	Receive FIFO Buffer Access Pointer Register x	RSCANnRFPTRx	<RSCFDn_base> + H'0E04 + (H'10 × x)
RSCANn	Receive FIFO Buffer Access Data Field 0 Register x	RSCANnRFDF0_x	<RSCFDn_base> + H'0E08 + (H'10 × x)
RSCANn	Receive FIFO Buffer Access Data Field 1 Register x	RSCANnRFDF1_x	<RSCFDn_base> + H'0E0C + (H'10 × x)
Transmit/Receive FIFO buffer related registers			
RSCANn	Transmit/receive FIFO Buffer Configuration and Control Register k	RSCANnCFCCk	<RSCFDn_base> + H'0118 + (H'04 × k)
RSCANn	Transmit/receive FIFO Buffer Status Register k	RSCANnCFSTS	<RSCFDn_base> + H'0178 + (H'04 × k)
RSCANn	Transmit/receive FIFO Buffer Pointer Control Register k	RSCANnCFPCRk	<RSCFDn_base> + H'01D8 + (H'04 × k)
RSCANn	Transmit/receive FIFO Buffer Access ID Register k	RSCANnCFIDk	<RSCFDn_base> + H'0E80 + (H'10 × k)
RSCANn	Transmit/receive FIFO Buffer Access Pointer Register k	RSCANnCFPTRk	<RSCFDn_base> + H'0E84 + (H'10 × k)
RSCANn	Transmit/receive FIFO Buffer Access Data Field 0 Register k	RSCANnCFDF0_k	<RSCFDn_base> + H'0E88 + (H'10 × k)
RSCANn	Transmit/receive FIFO Buffer Access Data Field 1 Register k	RSCANnCFDF1_k	<RSCFDn_base> + H'0E8C + (H'10 × k)
FIFO status-related registers			
RSCANn	FIFO Empty Status Register	RSCANnFESTS	<RSCFDn_base> + H'0238
RSCANn	FIFO Full Status Register	RSCANnFFSTS	<RSCFDn_base> + H'023C
RSCANn	FIFO Message Lost Status Register	RSCANnFMSTS	<RSCFDn_base> + H'0240
RSCANn	RSCANn FIFO Receive FIFO Buffer Interrupt Flag Status Register	RSCANnRFISTS	<RSCFDn_base> + H'0244
RSCANn	Transmit/receive FIFO Buffer Receive Interrupt Flag Status Register	RSCANnCFRISTS	<RSCFDn_base> + H'0248
RSCANn	Transmit/receive FIFO Buffer Transmit Interrupt Flag Status Register	RSCANnCFTISTS	<RSCFDn_base> + H'024C
Transmit buffer-related registers			
RSCANn	Transmit Buffer Control Register p	RSCANnTMCp	<RSCFDn_base> + H'0250 + (H'01 × p)
RSCANn	Transmit Buffer Status Register p	RSCANnTMSTSp	<RSCFDn_base> + H'02D0 + (H'01 × p)
RSCANn	Transmit Buffer ID Register p	RSCANnTMIDp	<RSCFDn_base> + H'1000 + (H'10 × p)
RSCANn	Transmit Buffer Pointer Register p	RSCANnTMPTRp	<RSCFDn_base> + H'1004 + (H'10 × p)
RSCANn	Transmit Buffer Data Field 0 Register p	RSCANnTMDf0_p	<RSCFDn_base> + H'1008 + (H'10 × p)
RSCANn	Transmit Buffer Data Field 1 Register p	RSCANnTMDf1_p	<RSCFDn_base> + H'100C + (H'10 × p)
RSCANn	Transmit Buffer Interrupt Enable Configuration Register y	RSCANnTMIECy	<RSCFDn_base> + H'0390 + (H'04 × y)
Transmit buffer status-related registers			
RSCANn	Transmit Buffer Transmit Request Status Register y	RSCANnTMTRSTSy	<RSCFDn_base> + H'0350 + (H'04 × y)
RSCANn	Transmit Buffer Transmit Abort Request Status Register y	RSCANnTMTARSTSy	<RSCFDn_base> + H'0360 + (H'04 × y)
RSCANn	Transmit Buffer Transmit Complete Status Register y	RSCANnTMTCASTSy	<RSCFDn_base> + H'0370 + (H'04 × y)
RSCANn	Transmit Buffer Transmit Abort Status Register y	RSCANnTMTASTSy	<RSCFDn_base> + H'0380 + (H'04 × y)
Transmit queue-related registers			
RSCANn	Transmit Queue Configuration and Control Register m	RSCANnTXQCCm	<RSCFDn_base> + H'03A0 + (H'04 × m)
RSCANn	Transmit Queue Status Register m	RSCANnTXQSTSm	<RSCFDn_base> + H'03C0 + (H'04 × m)
RSCANn	Transmit Queue Pointer Control Register m	RSCANnTXQPCTRm	<RSCFDn_base> + H'03E0 + (H'04 × m)

Table 28.10 Registers (3/3)

Module	Register	Symbol	Address
Transmit history-related registers			
RSCANn	Transmit History Configuration and Control Register m	RSCANnTHLCCm	<RSCFDn_base> + H'0400 + (H'04 × m)
RSCANn	Transmit History Status Register m	RSCANnTHLSTSm	<RSCFDn_base> + H'0420 + (H'04 × m)
RSCANn	Transmit History Pointer Control Register m	RSCANnTHLPCTRm	<RSCFDn_base> + H'0440 + (H'04 × m)
RSCANn	Transmit History Access Register m	RSCANnTHLACCm	<RSCFDn_base> + H'1800 + (H'04 × m)
Test-related registers			
RSCANn	Global Test Configuration Register	RSCANnGTSTCFG	<RSCFDn_base> + H'0468
RSCANn	Global Test Control Register	RSCANnGTSTCTR	<RSCFDn_base> + H'046C
RSCANn	Global Lock Key Register	RSCANnGLOCKK	<RSCFDn_base> + H'047C
RSCANn	RAM Test Page Access Register r	RSCANnRPGACCr	<RSCFDn_base> + H'1900 + (H'04 × r)

Table 28.11 Transmit Buffer p Allocated to Each Channel

	CANm
Transmit buffer p	Transmit buffer 16 × m + 0
	Transmit buffer 16 × m + 1
	Transmit buffer 16 × m + 2
	Transmit buffer 16 × m + 3
	Transmit buffer 16 × m + 4
	Transmit buffer 16 × m + 5
	Transmit buffer 16 × m + 6
	Transmit buffer 16 × m + 7
	Transmit buffer 16 × m + 8
	Transmit buffer 16 × m + 9
	Transmit buffer 16 × m + 10
	Transmit buffer 16 × m + 11
	Transmit buffer 16 × m + 12
	Transmit buffer 16 × m + 13
	Transmit buffer 16 × m + 14
	Transmit buffer 16 × m + 15

Table 28.12 Transmit/Receive FIFO Buffer k Allocated to Each Channel

	CANm
Transmit/receive FIFO buffer k	Transmit/receive FIFO buffer 3 × m + 0
	Transmit/receive FIFO buffer 3 × m + 1
	Transmit/receive FIFO buffer 3 × m + 2

Table 28.13 Transmit Buffer p Linked to the Transmit/Receive FIFO Buffer by the Setting of Bits CFTML[3:0]

Setting of Bits CFTML[3:0]	Transmit Buffer p Linked to the Transmit/Receive FIFO Buffer
0000b	Transmit buffer 16 × m + 0
0001b	Transmit buffer 16 × m + 1
0010b	Transmit buffer 16 × m + 2
0011b	Transmit buffer 16 × m + 3
0100b	Transmit buffer 16 × m + 4
0101b	Transmit buffer 16 × m + 5
0110b	Transmit buffer 16 × m + 6
0111b	Transmit buffer 16 × m + 7
1000b	Transmit buffer 16 × m + 8
1001b	Transmit buffer 16 × m + 9
1010b	Transmit buffer 16 × m + 10
1011b	Transmit buffer 16 × m + 11
1100b	Transmit buffer 16 × m + 12
1101b	Transmit buffer 16 × m + 13
1110b	Transmit buffer 16 × m + 14
1111b	Transmit buffer 16 × m + 15

Table 28.14 Transmit Buffer p Allocated to the Transmit Queue of Each Channel

Setting of Bits TXQDC[3:0]	Transmit Buffer p Allocated to the Transmit Queue
0000b	Setting prohibited
0001b	Setting prohibited
0010b	Transmit buffer 16 × m + 15 to 16 × m + 13
0011b	Transmit buffer 16 × m + 15 to 16 × m + 12
0100b	Transmit buffer 16 × m + 15 to 16 × m + 11
0101b	Transmit buffer 16 × m + 15 to 16 × m + 10
0110b	Transmit buffer 16 × m + 15 to 16 × m + 9
0111b	Transmit buffer 16 × m + 15 to 16 × m + 8
1000b	Transmit buffer 16 × m + 15 to 16 × m + 7
1001b	Transmit buffer 16 × m + 15 to 16 × m + 6
1010b	Transmit buffer 16 × m + 15 to 16 × m + 5
1011b	Transmit buffer 16 × m + 15 to 16 × m + 4
1100b	Transmit buffer 16 × m + 15 to 16 × m + 3
1101b	Transmit buffer 16 × m + 15 to 16 × m + 2
1110b	Transmit buffer 16 × m + 15 to 16 × m + 1
1111b	Transmit buffer 16 × m + 15 to 16 × m + 0

28.3.2 Details of Interface Mode-related Registers

28.3.2.1 RSCANnGRMCFG — Global Interface Mode Select Register

Access Size: RSCANnGRMCFG register can be read/written in 32-bit units
 RSCANnGRMCFG, RSCANnGRMCFG registers can be read/written in 16-bit units
 RSCANnGRMCFG, RSCANnGRMCFG registers can be read/written in 8-bit units

Address(es): RSCANnGRMCFG: <RSCFDn_base> + H'04FC, RSCANnGRMCFG: <RSCFDn_base> + H'04FC,
 RSCANnGRMCFG: <RSCFDn_base> + H'04FE, RSCANnGRMCFG: <RSCFDn_base> + H'04FC,
 RSCANnGRMCFG: <RSCFDn_base> + H'04FD, RSCANnGRMCFG: <RSCFDn_base> + H'04FE,
 RSCANnGRMCFG: <RSCFDn_base> + H'04FF

Initial Value: H'0000 0000

Bit	31	30	29	28	27	26	25	24	23	22	21	20	19	18	17	16
	—	—	—	—	—	—	—	—	—	—	—	—	—	—	—	—
Initial Value	0	0	0	0	0	0	0	0	0	0	0	0	0	0	0	0
R/W	R	R	R	R	R	R	R	R	R	R	R	R	R	R	R	R
Bit	15	14	13	12	11	10	9	8	7	6	5	4	3	2	1	0
	—	—	—	—	—	—	—	—	—	—	—	—	—	—	—	RCMC
Initial Value	0	0	0	0	0	0	0	0	0	0	0	0	0	0	0	0
R/W	R	R	R	R	R	R	R	R	R	R	R	R	R	R	R	R/W

Bit	Bit Name	Initial Value	R/W	Description
31 to 1	—	All 0	R	Reserved These bits are read as the value after reset. The write value should be the value after reset.
0	RCMC	0	R/W	Interface Mode Select 0: Classical CAN mode 1: CANFD mode

Note: The RSCANnGRMCFG register and the RSCFDnCFDGRMCFG register are the same register. Therefore, set either one of the registers.

Modify the RSCANnGRMCFG register only in global reset mode. Before setting other RS-CANFD registers, set this register.

RCMC Bit

Setting this bit to 0 places the RS-CANFD module in classical CAN mode.

Setting this bit to 1 places the RS-CANFD module in CANFD mode. To switch CANFD mode to classical CAN mode, set the value after reset in all registers and bits allocated to the register map of CANFD mode and then modify the RSCANnGRMCFG register.

28.3.3 Details of Channel-related Registers

28.3.3.1 RSCANnCmCFG — Channel Configuration Register (m = 0, 1)

Access Size: RSCANnCmCFG register can be read/written in 32-bit units
 RSCANnCmCFG, RSCANnCmCFGH registers can be read/written in 16-bit units
 RSCANnCmCFGLL, RSCANnCmCFGHL, RSCANnCmCFGHL, RSCANnCmCFGHH registers can be read/written in 8-bit units

Address(es): RSCANnCmCFG: <RSCFDn_base> + H'0000 + (H'10 × m)
 RSCANnCmCFG: <RSCFDn_base> + H'0000 + (H'10 × m),
 RSCANnCmCFGH: <RSCFDn_base> + H'0002 + (H'10 × m)
 RSCANnCmCFGLL: <RSCFDn_base> + H'0000 + (H'10 × m),
 RSCANnCmCFGHL: <RSCFDn_base> + H'0001 + (H'10 × m),
 RSCANnCmCFGHL: <RSCFDn_base> + H'0002 + (H'10 × m),
 RSCANnCmCFGHH: <RSCFDn_base> + H'0003 + (H'10 × m)

Initial Value: H'0000 0000

Bit	31	30	29	28	27	26	25	24	23	22	21	20	19	18	17	16	
	—	—	—	—	—	—	SJW[1:0]		—	TSEG2[2:0]		TSEG1[3:0]					
Initial Value	0	0	0	0	0	0	0	0	0	0	0	0	0	0	0	0	
R/W	R	R	R	R	R	R	R/W	R/W	R	R/W	R/W	R/W	R/W	R/W	R/W	R/W	
Bit	15	14	13	12	11	10	9	8	7	6	5	4	3	2	1	0	
	—	—	—	—	—	—	BRP[9:0]										
Initial Value	0	0	0	0	0	0	0	0	0	0	0	0	0	0	0	0	
R/W	R	R	R	R	R	R	R/W	R/W	R/W	R/W	R/W	R/W	R/W	R/W	R/W	R/W	

Bit	Bit Name	Initial Value	R/W	Description
31 to 26	—	All 0	R	Reserved These bits are read as the value after reset. The write value should be the value after reset.
25, 24	SJW[1:0]	All 0	R/W	Resynchronization Jump Width Control b25 b24 0 0: 1 Tq 0 1: 2 Tq 1 0: 3 Tq 1 1: 4 Tq
23	—	0	R	Reserved This bit is read as the value after reset. The write value should be the value after reset.
22 to 20	TSEG2[2:0]	All 0	R/W	Time Segment 2 Control b22 b21 b20 0 0 0: Setting prohibited 0 0 1: 2 Tq 0 1 0: 3 Tq 0 1 1: 4 Tq 1 0 0: 5 Tq 1 0 1: 6 Tq 1 1 0: 7 Tq 1 1 1: 8 Tq

Bit	Bit Name	Initial Value	R/W	Description
19 to 16	TSEG1[3:0]	All 0	R/W	Time Segment 1 Control b19 b18 b17 b16 0 0 0 0: Setting prohibited 0 0 0 1: Setting prohibited 0 0 1 0: Setting prohibited 0 0 1 1: 4 Tq 0 1 0 0: 5 Tq 0 1 0 1: 6 Tq 0 1 1 0: 7 Tq 0 1 1 1: 8 Tq 1 0 0 0: 9 Tq 1 0 0 1: 10 Tq 1 0 1 0: 11 Tq 1 0 1 1: 12 Tq 1 1 0 0: 13 Tq 1 1 0 1: 14 Tq 1 1 1 0: 15 Tq 1 1 1 1: 16 Tq
15 to 10	—	All 0	R	Reserved These bits are read as the value after reset. The write value should be the value after reset.
9 to 0	BRP[9:0]	All 0	R/W	Prescaler Division Ratio Set When these bits are set to P (0 to 1023), the baud rate prescaler divides fCAN by P + 1.

Modify the RSCANnCMCFG register in channel reset mode or channel halt mode. Set this register in channel reset mode before shifting to channel communication mode or channel halt mode. For a description of the bit timing parameters and settings, see **Section 28.11.1, Initial Settings**.

SJW[1:0] Bits

These bits are used to specify a Tq value for the resynchronization jump width.

Allowed values are 1 Tq to 4 Tq, inclusive.

Set a value less than or equal to the value of the TSEG2 bits.

TSEG2[2:0] Bits

These bits are used to specify a Tq value for the length of phase segment 2 (PHASE_SEG2).

Allowed values are 2 Tq to 8 Tq, inclusive.

Set a value smaller than the value of the TSEG1 bits.

TSEG1[3:0] Bits

These bits are used to specify a Tq value for the total length of the propagation segment (PROP_SEG) and phase segment 1 (PHASE_SEG1).

Allowed values are 4 Tq to 16 Tq, inclusive.

BRP[9:0] Bits

The CANmTq clock (fCANTQm) is calculated by dividing the CAN clock (fCAN) by the baud rate prescaler, ((BRP[9:0]) + 1). One clock cycle of the CANmTq clock is 1 Time Quantum (Tq).

28.3.3.2 RSCANnCmCTR — Channel Control Register (m = 0, 1)

Access Size: RSCANnCmCTR register can be read/written in 32-bit units
 RSCANnCmCTRL, RSCANnCmCTRH registers can be read/written in 16-bit units
 RSCANnCmCTRL, RSCANnCmCTRLH, RSCANnCmCTRHL, RSCANnCmCTRHH registers can be read/written in 8-bit units

Address(es): RSCANnCmCTR: <RSCFDn_base> + H'0004 + (H'10 × m)
 RSCANnCmCTRL: <RSCFDn_base> + H'0004 + (H'10 × m),
 RSCANnCmCTRH: <RSCFDn_base> + H'0006 + (H'10 × m)
 RSCANnCmCTRL: <RSCFDn_base> + H'0004 + (H'10 × m),
 RSCANnCmCTRLH: <RSCFDn_base> + H'0005 + (H'10 × m),
 RSCANnCmCTRHL: <RSCFDn_base> + H'0006 + (H'10 × m),
 RSCANnCmCTRHH: <RSCFDn_base> + H'0007 + (H'10 × m)

Initial Value: H'0000 0005

Bit	31	30	29	28	27	26	25	24	23	22	21	20	19	18	17	16
	—	CRCT	—	—	—	CTMS[1:0]		CTME	ERRD	BOM[1:0]		—	—	—	—	TAIE
Initial Value	0	0	0	0	0	0	0	0	0	0	0	0	0	0	0	0
R/W	R	R/W	R	R	R	R/W	R/W	R/W	R/W	R/W	R/W	R	R	R	R	R/W
Bit	15	14	13	12	11	10	9	8	7	6	5	4	3	2	1	0
	ALIE	BLIE	OLIE	BORIE	BOEIE	EPIE	EWIE	BEIE	—	—	—	—	RTBO	CSLPR	CHMDC[1:0]	
Initial Value	0	0	0	0	0	0	0	0	0	0	0	0	0	1	0	1
R/W	R/W	R/W	R/W	R/W	R/W	R/W	R/W	R/W	R	R	R	R	R/W	R/W	R/W	R/W

Bit	Bit Name	Initial Value	R/W	Description
31	—	0	R	Reserved This bit is read as the value after reset. The write value should be the value after reset.
30	CRCT	0	R/W	CRC Error Test Enable 0: The first bit of the reception ID field is not inverted. 1: The first bit of the reception ID field is inverted.
29 to 27	—	All 0	R	Reserved These bits are read as the value after reset. The write value should be the value after reset.
26, 25	CTMS[1:0]	All 0	R/W	Communication Test Mode Select b26 b25 0 0: Standard test mode 0 1: Listen-only mode 1 0: Self-test mode 0 (external loopback mode) 1 1: Self-test mode 1 (internal loopback mode)
24	CTME	0	R/W	Communication Test Mode Enable 0: Communication test mode is disabled. 1: Communication test mode is enabled.
23	ERRD	0	R/W	Error Display Mode Select 0: Error flags are displayed only for the first error information after bits 14 to 8 in the RSCANnCmERFL register are all cleared. 1: Error flags for all error information are displayed.

Bit	Bit Name	Initial Value	R/W	Description
22, 21	BOM[1:0]	All 0	R/W	Bus Off Recovery Mode Select b22 b21 0 0: ISO11898-1 compliant 0 1: Entry to channel halt mode automatically at bus-off entry 1 0: Entry to channel halt mode automatically at bus-off end 1 1: Entry to channel halt mode (in bus-off state) by program request
20 to 17	—	All 0	R	Reserved These bits are read as the value after reset. The write value should be the value after reset.
16	TAIE	0	R/W	Transmit Abort Interrupt Enable 0: Transmit abort interrupt is disabled. 1: Transmit abort interrupt is enabled.
15	ALIE	0	R/W	Arbitration Lost Interrupt Enable 0: Arbitration lost interrupt is disabled. 1: Arbitration lost interrupt is enabled.
14	BLIE	0	R/W	Bus Lock Interrupt Enable 0: Bus lock interrupt is disabled. 1: Bus lock interrupt is enabled.
13	OLIE	0	R/W	Overload Frame Transmit Interrupt Enable 0: Overload frame transmit interrupt is disabled. 1: Overload frame transmit interrupt is enabled.
12	BORIE	0	R/W	Bus Off Recovery Interrupt Enable 0: Bus off recovery interrupt is disabled. 1: Bus off recovery interrupt is enabled.
11	BOEIE	0	R/W	Bus Off Entry Interrupt Enable 0: Bus off entry interrupt is disabled. 1: Bus off entry interrupt is enabled.
10	EPIE	0	R/W	Error Passive Interrupt Enable 0: Error passive interrupt is disabled. 1: Error passive interrupt is enabled.
9	EWIE	0	R/W	Error Warning Interrupt Enable 0: Error warning interrupt is disabled. 1: Error warning interrupt is enabled.
8	BEIE	0	R/W	Bus Error Interrupt Enable 0: Bus error interrupt is disabled. 1: Bus error interrupt is enabled.
7 to 4	—	All 0	R	Reserved These bits are read as the value after reset. The write value should be the value after reset.
3	RTBO	0	R/W	Forcible Return from Bus-off When this bit is set to 1, forcible return from the bus off state is made. This bit is always read as 0.
2	CSLPR	1	R/W	Channel Stop Mode 0: Other than channel stop mode 1: Channel stop mode
1, 0	CHMDC[1:0]	01b	R/W	Mode Select b1 b0 0 0: Channel communication mode 0 1: Channel reset mode 1 0: Channel halt mode 1 1: Setting prohibited

CRCT Bit

This bit is used to test the CRC generation circuit in the RS-CANFD module. Setting this bit to 1 inverts the first bit of the ID field when a message is received. With this inversion of bit, the CRC calculation result does not match the normal CRC value of the received frame, which can detect a CRC error (the CERR bit in the RSCANnCMERFL register is 1). When using this function, note the following.

- This function is available while the CTME bit in the RSCANnCMCTR register is 1 (communication test mode enabled).
- This function cannot communicate with other CAN nodes. Use this function for inter-channel communication test (the CmICBCE bit in the RSCANnGTSTCFG register is 1).
- Bit inversion in the ID field may cause bit stuffing rule violation. In that case, no CRC error is detected but a stuff error is detected.

Modify this bit only in channel halt mode. This bit is always 0 in channel reset mode.

CTMS[1:0] Bit

These bits are used to select a communication test mode. Modify these bits in channel halt mode only. These bits are set to 0 in channel reset mode.

CTME Bit

Setting this bit to 1 enables communication test mode. Modify this bit in channel halt mode. This bit is set to 0 in channel reset mode.

ERRD Bit

This bit is used to control the display mode of bits 14 to 8 in the RSCANnCMERFL register.

When this bit is clear to 0, if any error is detected while the flags of bits 14-8 in the RSCANnCMERFL register are all 0, only the flags of the first error event are set to 1. If two or more errors occur in the first error event, all the flags of the detected errors are set to 1.

When this bit is set to 1, all the flags of errors that have occurred are set to 1 regardless of the error occurrence order. Modify this bit only in channel reset mode or channel halt mode.

BOM[1:0] Bit

These bits are used to select the bus off recovery mode of the RS-CANFD module.

When the BOM[1:0] bits are set to 00b, return from the bus off state to the error active state is compliant with the CAN specifications. That is, the RS-CANFD module reenters the CAN communication (error active state) after 11 consecutive recessive bits are detected 128 times. A bus off recovery interrupt request is generated at the time of return from the bus off state. Even if the CHMDC[1:0] bits are set to 10b (channel halt mode) before recessive bits are detected 128 times, the RS-CANFD module does not transition to channel halt mode until recessive bits are detected 128 times.

When the RS-CANFD module reaches the bus off state when the BOM[1:0] bits are set to 01b, the CHMDC[1:0] bits in the RSCFDnCMCTRSCANnCMCTR register (m = 0, 1) are set to 10b and the RS-CANFD module transitions to channel halt mode. No bus off recovery interrupt request is generated and the TEC[7:0] and REC[7:0] bits in the RSCFDnCMSTSRSCANnCMSTS register are cleared to H'00.

When the RS-CANFD module reaches the bus off state when the BOM[1:0] bits are set to 10b, the CHMDC[1:0] bits are set to 10b and the RS-CANFD module transitions to channel halt mode after return from the bus off state (11 consecutive recessive bits are detected 128 times). A bus off recovery interrupt request is generated at the time of return from the bus off state and the TEC[7:0] and REC[7:0] bits are cleared to H'00.

When the BOM[1:0] bits are set to 11b and the CHMDC[1:0] bits are set to 10b while the RS-CANFD module is in the bus off state, the RS-CANFD module transitions to channel halt mode. No bus off recovery interrupt request is generated at the time of return from the bus off state and the TEC[7:0] and REC[7:0] bits are cleared to H'00. However, if 11 consecutive recessive bits are detected 128 times and the RS-CANFD module has recovered to the error active state from the bus off state before the CHMDC[1:0] bits are set to 10b, a bus off recovery interrupt request is generated.

If a program writes to the CHMDC[1:0] bit at the same time as the RS-CANFD module transition to channel halt mode (at bus off entry when the BOM[1:0] bits are 01b or at bus off end when the BOM[1:0] bits are 10b), the program's writing takes precedence. Modify the BOM[1:0] bits only in channel reset mode.

TAIE Bit

When transmit abort of the transmit buffer is completed with the TAIE bit set to 1, an interrupt request is generated. Modify this bit only in channel reset mode.

ALIE Bit

When the ALF flag in the RSCANnCmERFL register is set to 1 with the ALIE bit set to 1, an error interrupt request is generated. Modify this bit only in channel reset mode.

BLIE Bit

When the BLF flag in the RSCANnCmERFL register is set to 1 with the BLIE bit set to 1, an error interrupt request is generated. Modify this bit only in channel reset mode.

OLIE Bit

When the OVLf flag in the RSCANnCmERFL register is set to 1 with the OLIE bit set to 1, an error interrupt request is generated. Modify this bit only in channel reset mode.

BORIE Bit

When the BORF flag in the RSCANnCmERFL register is set to 1 with the BORIE bit set to 1, an error interrupt request is generated. Modify this bit only in channel reset mode.

BOEIE Bit

When the BOEF flag in the RSCANnCmERFL register is set to 1 with the BOEIE bit set to 1, an error interrupt request is generated. Modify this bit only in channel reset mode.

EPIE Bit

When the EPF flag in the RSCANnCmERFL register is set to 1 with the EPIE bit set to 1, an error interrupt request is generated. Modify this bit only in channel reset mode.

EWIE Bit

When the EWF flag in the RSCANnCmERFL register is set to 1 with the EWIE bit set to 1, an error interrupt request is generated. Modify this bit only in channel reset mode.

BEIE Bit

When the BEF flag in the RSCANnCmERFL register is set to 1 with the BEIE bit set to 1, an error interrupt request is generated. Modify this bit only in channel reset mode.

RTBO Bit

Setting this bit to 1 in the bus off state forcibly returns the state from the bus off state to the error active state. This bit is automatically cleared to 0. Setting this bit to 1 clears the TEC[7:0] and REC[7:0] bits in the RSCANn CmSTS register to H'00 and also clears the BOSTS flag in the RSCANn CmSTS register to 0 (not in bus off state). The other registers remain unchanged. No bus off recovery interrupt request is generated upon return from the bus off state in this case. Use this bit only when the BOM[1:0] bits in the RSCANn CmCTR register are 00b (ISO11898-1 compliant).

A delay of up to 1 CAN bit time occurs after the RTBO bit is set to 1 until the RSCAN module transitions to the error active state. Set this bit to 1 in channel communication mode.

CSLPR Bit

Setting this bit to 1 places the channel into channel stop mode. Clearing this bit to 0 makes the channel exit channel stop mode.

This bit should not be modified in channel communication mode or channel halt mode.

CHMDC[1:0] Bit

These bits are used to select a channel mode (channel communication mode, channel reset mode, or channel halt mode). For details, see **Section 28.6.2, Channel Modes**. Setting the CSLPR bit to 1 in channel reset mode allows transition to channel stop mode. Do not set the CHMDC[1:0] bits to 11b. When the CAN module has automatically transitioned to channel halt mode based on the setting of the BOM[1:0] bits, the CHMDC[1:0] bits automatically become 10b.

28.3.3.3 RSCANnCmSTS — Channel Status Register (m = 0, 1)

Access Size: RSCANnCmSTS register can be read only in 32-bit units
 RSCANnCmSTSL, RSCANnCmSTSH registers can be read only in 16-bit units
 RSCANnCmSTSLL, RSCANnCmSTSLH, RSCANnCmSTSHL, RSCANnCmSTSHH registers can be read only in 8-bit units

Address(es): RSCANnCmSTS: <RSCFDn_base> + H'0008 + (H'10 × m)
 RSCANnCmSTSL: <RSCFDn_base> + H'0008 + (H'10 × m),
 RSCANnCmSTSH: <RSCFDn_base> + H'000A + (H'10 × m)
 RSCANnCmSTSLL: <RSCFDn_base> + H'0008 + (H'10 × m),
 RSCANnCmSTSLH: <RSCFDn_base> + H'0009 + (H'10 × m),
 RSCANnCmSTSHL: <RSCFDn_base> + H'000A + (H'10 × m),
 RSCANnCmSTSHH: <RSCFDn_base> + H'000B + (H'10 × m)

Initial Value: H'0000 0005

Bit	31	30	29	28	27	26	25	24	23	22	21	20	19	18	17	16
	TEC[7:0]								REC[7:0]							
Initial Value	0	0	0	0	0	0	0	0	0	0	0	0	0	0	0	0
R/W	R	R	R	R	R	R	R	R	R	R	R	R	R	R	R	R
Bit	15	14	13	12	11	10	9	8	7	6	5	4	3	2	1	0
	—	—	—	—	—	—	—	—	COMSTS	RECSTS	TRMSTS	BOSTS	EPSTS	CSLPSTS	CHLTSTS	CRSTS
Initial Value	0	0	0	0	0	0	0	0	0	0	0	0	0	1	0	1
R/W	R	R	R	R	R	R	R	R	R	R	R	R	R	R	R	R

Bit	Bit Name	Initial Value	R/W	Description
31 to 24	TEC[7:0]	All 0	R	The transmit error counter (TEC) can be read.
23 to 16	REC[7:0]	All 0	R	The receive error counter (REC) can be read.
15 to 8	—	All 0	R	Reserved These bits are read as the value after reset.
7	COMSTS	0	R	Communication Status Flag 0: Communication is not ready. 1: Communication is ready.
6	RECSTS	0	R	Receive Status Flag 0: Bus idle, in transmission or bus off state 1: In reception
5	TRMSTS	0	R	Transmit Status Flag 0: Bus idle or in reception 1: In transmission or bus off state
4	BOSTS	0	R	Bus Off Status Flag 0: Not in bus off state 1: In bus off state
3	EPSTS	0	R	Error Passive Status Flag 0: Not in error passive state 1: In error passive state
2	CSLPSTS	1	R	Channel Stop Status Flag 0: Not in channel stop mode 1: In channel stop mode
1	CHLTSTS	0	R	Channel Halt Status Flag 0: Not in channel halt mode 1: In channel halt mode

Bit	Bit Name	Initial Value	R/W	Description
0	CRSTSTS	1	R	Channel Reset Status Flag 0: Not in channel reset mode 1: In channel reset mode

TEC[7:0] Bits

These bits contain the transmit error counter value. For transmit error counter increment/decrement conditions, see the CAN specification (ISO11898-1).

These bits are cleared to 0 in channel reset mode.

REC[7:0] Bits

These bits contain the receive error counter value. For receive error counter increment/decrement conditions, see the CAN specifications (ISO11898-1).

These bits are cleared to 0 in channel reset mode.

COMSTS Flag

This bit indicates that communication is ready.

This flag becomes 1 when the CAN module has detected 11 consecutive recessive bits after it has transitioned from channel reset mode or channel halt mode to channel communication mode. This flag is cleared to 0 in channel reset mode or channel halt mode.

RECSTS Flag

This flag is set to 1 when reception has started, and is cleared to 0 when the bus has become idle or transmission has started.

TRMSTS Flag

This flag is set to 1 when transmission has started, and is cleared to 0 when the bus has become idle or reception has started. This flag remains 1 in the bus off state.

BOSTS Flag

This flag is set to 1 when the bus off state ($TEC[7:0] > 255$) is entered. It is cleared to 0 when the CAN module has exited the bus off state.

EPSTS Flag

This flag is set to 1 when the RS-CANFD module has entered the error passive state ($(128 \leq TEC[7:0] \leq 255)$ or $(128 \leq REC[7:0])$), It is cleared to 0 when the RS-CANFD module has exited the error passive state or has entered channel reset mode.

CSLPSTS Flag

This flag is set to 1 when the CAN module has transitioned to channel stop mode, and is cleared to 0 when the CAN module has returned from channel stop mode.

CHLTSTS Flag

This flag is set to 1 when the CAN module has transitioned to channel halt mode, and is cleared to 0 when the CAN module has returned from channel halt mode.

CRSTSTS Flag

This flag is set to 1 when the CAN module has transitioned to channel reset mode, and is cleared to 0 when the CAN module has transitioned to channel communication mode or channel halt mode. This flag remains 1 when the CAN module transitions from channel reset mode to channel stop mode.

28.3.3.4 RSCANnCmERFL — Channel Error Flag Register (m = 0, 1)

Access Size: RSCANnCmERFL register can be read/written in 32-bit units
 RSCANnCmERFLL, RSCANnCmERFLH registers can be read/written in 16-bit units
 RSCANnCmERFLLL, RSCANnCmERFLH, RSCANnCmERFLHL, RSCANnCmERFLHH registers can be read/written in 8-bit units

Address(es): RSCANnCmERFL: <RSCFDn_base> + H'000C + (H'10 × m)
 RSCANnCmERFLL: <RSCFDn_base> + H'000C + (H'10 × m),
 RSCANnCmERFLH: <RSCFDn_base> + H'000E + (H'10 × m)
 RSCANnCmERFLLL: <RSCFDn_base> + H'000C + (H'10 × m),
 RSCANnCmERFLH: <RSCFDn_base> + H'000D + (H'10 × m),
 RSCANnCmERFLHL: <RSCFDn_base> + H'000E + (H'10 × m),
 RSCANnCmERFLHH: <RSCFDn_base> + H'000F + (H'10 × m)

Initial Value: H'0000 0000

Bit	31	30	29	28	27	26	25	24	23	22	21	20	19	18	17	16
	—	CRCREG[14:0]														
Initial Value	0	0	0	0	0	0	0	0	0	0	0	0	0	0	0	0
R/W	R	R	R	R	R	R	R	R	R	R	R	R	R	R	R	R
Bit	15	14	13	12	11	10	9	8	7	6	5	4	3	2	1	0
	—	ADERR	B0ERR	B1ERR	CERR	AERR	FERR	SERR	ALF	BLF	OVLF	BORF	BOEF	EPF	EWf	BEF
Initial Value	0	0	0	0	0	0	0	0	0	0	0	0	0	0	0	0
R/W	R	R/W*1	R/W*1	R/W*1	R/W*1	R/W*1	R/W*1	R/W*1	R/W*1	R/W*1	R/W*1	R/W*1	R/W*1	R/W*1	R/W*1	R/W*1

Bit	Bit Name	Initial Value	R/W	Description
31	—	0	R	Reserved When read, the value after reset is returned. When writing to this bit, write the value after reset.
30 to 16	CRCREG [14:0]	All 0	R	CRC Calculation Data A CRC value calculated based on the transmit message or receive message is indicated.
15	—	0	R	Reserved When read, the value after reset is returned. When writing to this bit, write the value after reset.
14	ADERR	0	R/W*1	ACK Delimiter Error Flag 0: No ACK delimiter error is detected. 1: ACK delimiter error is detected.
13	B0ERR	0	R/W*1	Dominant Bit Error Flag 0: No dominant bit error is detected. 1: Dominant bit error is detected.
12	B1ERR	0	R/W*1	Recessive Bit Error Flag 0: No recessive bit error is detected. 1: Recessive bit error is detected.
11	CERR	0	R/W*1	CRC Error Flag 0: No CRC error is detected. 1: CRC error is detected.
10	AERR	0	R/W*1	ACK Error Flag 0: No ACK error is detected. 1: ACK error is detected.

Bit	Bit Name	Initial Value	R/W	Description
9	FERR	0	R/W*1	Form Error Flag 0: No form error is detected. 1: Form error is detected.
8	SERR	0	R/W*1	Stuff Error Flag 0: No stuff error is detected. 1: Stuff error is detected.
7	ALF	0	R/W*1	Arbitration-lost Flag 0: No arbitration-lost is detected. 1: Arbitration-lost is detected.
6	BLF	0	R/W*1	Bus Lock Flag 0: No channel bus is detected. 1: Channel bus is detected.
5	OVLF	0	R/W*1	Overload Flag 0: No overload is detected. 1: Overload is detected.
4	BORF	0	R/W*1	Bus Off Recovery Flag 0: No bus off recovery is detected. 1: Bus off recovery is detected.
3	BOEF	0	R/W*1	Bus Off Entry Flag 0: No bus off entry is detected. 1: Bus off entry is detected.
2	EPF	0	R/W*1	Error Passive Flag 0: No error passive is detected. 1: Error passive is detected.
1	EWF	0	R/W*1	Error Warning Flag 0: No error warning is detected. 1: Error warning is detected.
0	BEF	0	R/W*1	Bus Error Flag 0: No channel bus error is detected. 1: Channel bus error is detected.

Note 1. The only effective value for writing to this flag bit is 0, which clears the bit. Otherwise writing to the bit results in retention of its state.

See the CAN specification (ISO11898-1) for a description of error occurrence conditions. To clear each flag of this register, the program must write a 0 to the corresponding bit. These flags cannot be set to 1 by the program. If any of these flags is set to 0 at the same time that the program writes 0 to the flag, the flag is still set to 1. The channel reset mode transition clears all of these flags to 0.

If the ERRD bit in the RSCANnCMCTR register is set to 0 (i.e., only the flags for the first error event are displayed) and an error related to bits 14 to 8 of RSCANnCMERFL is detected, the flag bits are only set by the error event if bits 14 to 8 were all 0 at the when time the error occurred.

CRCREG[14:0] Flag

When the CTME bit in the RSCANnCMCTR register is set to 1 (communication test mode is enabled), the CRC value calculated based on the transmit or receive message can be read. When the CTME bit is set to 0 (communication test mode is disabled), these bits are always read as 0. This bit is always 0 in channel reset mode.

ADERR Flag

This flag is set to 1 when a form error has been detected in the ACK delimiter during transmission.

B0ERR Flag

This flag is set to 1 when a recessive bit has been detected though a dominant bit was transmitted.

B1ERR Flag

This flag is set to 1 when a dominant bit has been detected though a recessive bit was transmitted.

CERR Flag

This flag is set to 1 when a CRC error has been detected.

AERR Flag

This flag is set to 1 when an ACK error has been detected.

FERR Flag

This flag is set to 1 when a form error has been detected.

SERR Flag

This flag is set to 1 when a stuff error has been detected.

ALF Flag

This flag is set to 1 when an arbitration-lost has been detected.

BLF Flag

This flag is set to 1 when 32 consecutive dominant bits have been detected on the CAN bus in channel communication mode. After that, detection of a dominant lock is restarted when either of the following conditions is met.

- A recessive bit is detected after the BLF bit has been cleared from 1 to 0.
- The CAN module transitions to channel reset mode and returns to channel communication mode after the BLF bit has been cleared from 1 to 0

OVLf Flag

This flag is set to 1 when the overload frame transmit condition has been detected when performing reception or transmission.

BORF Flag

This flag is set to 1 when 11 consecutive recessive bits have been detected 128 times and the CAN module returns from the bus off state. However, this flag is not set to 1 if the CAN module returns from the bus off state in any of the following ways before 11 consecutive recessive bits are detected 128 times.

- The CHMDC[1:0] bits in the RSCANn CmCTR register are set to 01b (channel reset mode).
- The RTBO bit in the RSCANn CmCTR register is set to 1 (forcible return from the bus off state is made).
- The BOM[1:0] bits in the RSCANn CmCTR register are set to 01b (transition to channel halt mode at bus off entry).
- The CHMDC[1:0] bits in the RSCANn CmCTR register are set to 10b (channel halt mode) before 11 consecutive recessive bits are detected 128 times with the BOM[1:0] bits set to 11b (transition to channel halt mode upon a request from the program during bus off).

BOEF Flag

This flag is set to 1 when the bus off state is reached (TEC[7:0] value > 255). This flag is also set to 1 if the bus off state is reached when the BOM[1:0] bits in the RSCANnCMCTR register (m = 0, 1) set to 01b (transition to channel halt mode at bus off entry).

EPF Flag

This flag becomes 1 when the error passive state is reached (REC[7:0] or TEC[7:0] value > 127).

This flag becomes 1 only when the REC[7:0] or TEC[7:0] value first exceeds 127. Therefore, if the program writes 0 to this flag while the value of REC[7:0] or TEC[7:0] remains over 127, this bit is not set to 1 until both REC [7:0] and TEC[7:0] values become 127 or less and then the REC[7:0] or TEC[7:0] value exceeds 127 again.

EWF Flag

This flag is set to 1 only when the REC[7:0] or TEC[7:0] value first exceeds 95. Therefore, if the program writes 0 to this flag while the value of REC[7:0] or TEC[7:0] remains over 95, this bit is not set to 1 until both REC [7:0] and TEC[7:0] values become 95 or less and then the REC[7:0] or TEC[7:0] value exceeds 95 again.

BEF Flag

This flag is set to 1 when any one of the ADERR, BOERR, B1ERR, CERR, AERR, FERR, and SERR flags in the RSCANnCMERFL register is set to 1.

NOTE

To clear the flag of this register to 0, use a store instruction to write "0" to the given flag and "1" to the other flags.

28.3.4 Details of Global-related Registers

28.3.4.1 RSCANnGCFG — Global Configuration Register

Access Size: RSCANnGCFG register can be read/written in 32-bit units

RSCANnGCFG, RSCANnGCFGH registers can be read/written in 16-bit units

RSCANnGCFGLL, RSCANnGCFGHL, RSCANnGCFGHLL, RSCANnGCFGHHL registers can be read/written in 8-bit units

Address(es): RSCANnGCFG: <RSCFDn_base> + H'0084

RSCANnGCFG: <RSCFDn_base> + H'0084, RSCANnGCFGH: <RSCFDn_base> + H'0086

RSCANnGCFGLL: <RSCFDn_base> + H'0084, RSCANnGCFGHL: <RSCFDn_base> + H'0085,

RSCANnGCFGHLL: <RSCFDn_base> + H'0086, RSCANnGCFGHHL: <RSCFDn_base> + H'0087

Initial Value: H'0000 0000

Bit	31	30	29	28	27	26	25	24	23	22	21	20	19	18	17	16
	ITRCP[15:0]															
Initial Value	0	0	0	0	0	0	0	0	0	0	0	0	0	0	0	0
R/W	R/W	R/W	R/W	R/W	R/W	R/W	R/W	R/W	R/W	R/W	R/W	R/W	R/W	R/W	R/W	R/W
Bit	15	14	13	12	11	10	9	8	7	6	5	4	3	2	1	0
	TSBTCS[2:0]		TSSS		TSP[3:0]			TMTSC E		—	—	DCS	MME	DRE	DCE	TPRI
Initial Value	0	0	0	0	0	0	0	0	0	0	0	0	0	0	0	0
R/W	R/W	R/W	R/W	R/W	R/W	R/W	R/W	R/W	R/W	R	R	R/W	R/W	R/W	R/W	R/W

Bit	Bit Name	Initial Value	R/W	Description
31 to 16	ITRCP[15:0]	All 0	R/W	Interval Timer Prescaler Set When these bits are set to M, the pclk is divided by M. Setting H'0000 is prohibited when the interval timer is in use.
15 to 13	TSBTCS[2:0]	All 0	R/W	Timestamp Clock Source Select b15 b14 b13 0 0 0: Channel 0 bit time clock 0 0 1: Channel 1 bit time clock 0 1 0: Setting prohibited 0 1 1: Setting prohibited 1 0 0: Setting prohibited 1 0 1: Setting prohibited 1 1 0: Setting prohibited 1 1 1: Setting prohibited
12	TSSS	0	R/W	Timestamp Source Select 0: pclk/2*1 1: Bit time clock

Bit	Bit Name	Initial Value	R/W	Description
11 to 8	TSP[3:0]	All 0	R/W	Timestamp Clock Source Division b11 b10 b9 b8 0 0 0 0: Not divided 0 0 0 1: Divided by 2 0 0 1 0: Divided by 4 0 0 1 1: Divided by 8 0 1 0 0: Divided by 16 0 1 0 1: Divided by 32 0 1 1 0: Divided by 64 0 1 1 1: Divided by 128 1 0 0 0: Divided by 256 1 0 0 1: Divided by 512 1 0 1 0: Divided by 1024 1 0 1 1: Divided by 2048 1 1 0 0: Divided by 4096 1 1 0 1: Divided by 8192 1 1 1 0: Divided by 16384 1 1 1 1: Divided by 32768
7	TMTSCE	0	R/W	Transmission Timestamp Enable 0: Transmission timestamp is disabled. 1: Transmission timestamp is enabled.
6, 5	—	All 0	R	Reserved These bits are read as the value after reset. The write value should be the value after reset.
4	DCS	0	R/W	CAN Clock Source Select*2 0: clk 1: clk_xincan
3	MME	0	R/W	Mirror Function Enable 0: Mirror function is disabled. 1: Mirror function is enabled.
2	DRE	0	R/W	DLC Replacement Enable 0: DLC replacement is disabled. 1: DLC replacement is enabled.
1	DCE	0	R/W	DLC Check Enable 0: DLC check is disabled. 1: DLC check is enabled.
0	TPRI	0	R/W	Transmit Priority Select 0: ID priority 1: Transmit buffer number priority

Note 1. When specifying pclk/2 as the timestamp counter count source, set bits TSBTCS[2:0] to 000b.

Note 2. For the CAN clock frequency settings, see **Section 28.1.3, Clock Supply**.

Modify the RSCANnGCFCG register only in global reset mode.

ITRCP[15:0] Bits

These bits are used to set a clock source division value of the interval timer for FIFO buffers. See **Section 28.8.3.1, Interval Transmission Function**.

TSBTCS[2:0] Bits

When the TSSS bit is 1, these bits are used to select the channel of the bit time clock that will be the clock source of the timestamp counter.

TSSS Bits

This bit is used to select a clock source of the timestamp counter.

TSP[3:0] Bits

A clock obtained by dividing the clock source selected with the TSBTCS[2:0] bits and TSSS bit according to the TSP[3:0] bits is used as the timestamp counter count source.

TMTSCE Bits

Setting this bit to 1 makes it possible to store the timestamp of a transmitted message in the transmit history buffer. The timestamp is stored in TMTS[15:0] bits in the RSCANnTHLACCm register.

DCS Bits

When this bit is set to 0, clk_c is used as the clock source of the CAN clock (fCAN).

When this bit is set to 1, clk_{xincan} is used as the clock source of the CAN clock (fCAN). For the CAN clock frequency settings, see **Table 28.6**.

MME Bits

Setting this bit to 1 makes the mirror function available.

DRE Bits

When the DRE bit is set to 1, the DLC value of the receive rule is stored in the buffer instead of the DLC value of the received message after the DLC value has passed through the DLC filter. In this case, a value of H'00 is stored in each data byte beyond the DLC value of the receive rule.

The DLC replacement function is only available when the DCE bit is set to 1 (DLC check is enabled).

DCE Bits

Setting this bit to 1 makes the DLC check function available. When disabling the DLC check function, set the GAFLDLC[3:0] bits in the RSCANnGAFLP0_j register to 0000b before clearing the DCE bit in the RSCANnGCFG register to 0.

TPRI Bits

This bit is used to set the transmit priority.

When this bit is set to 0, ID priority is selected and the transmit priority complies with the CAN bus arbitration rule (ISO11898-1 specifications). When this bit is set to 1, transmit buffer number priority is selected and the lowest transmit buffer number of those has the highest priority.

While the transmit queue is in use, this bit should be set to 0.

28.3.4.2 RSCANnGCTR — Global Control Register

Access Size: RSCANnGCTR register can be read/written in 32-bit units
 RSCANnGCTRL, RSCANnGCTRH registers can be read/written in 16-bit units
 RSCANnGCTRL, RSCANnGCTRLH, RSCANnGCTRHL, RSCANnGCTRHH registers can be read/written in 8-bit units

Address(es): RSCANnGCTR: <RSCFDn_base> + H'0088
 RSCANnGCTRL: <RSCFDn_base> + H'0088, RSCANnGCTRH: <RSCFDn_base> + H'008A
 RSCANnGCTRL: <RSCFDn_base> + H'0088, RSCANnGCTRLH: <RSCFDn_base> + H'0089,
 RSCANnGCTRHL: <RSCFDn_base> + H'008A, RSCANnGCTRHH: <RSCFDn_base> + H'008B

Initial Value: H'0000 0005

Bit	31	30	29	28	27	26	25	24	23	22	21	20	19	18	17	16
	—	—	—	—	—	—	—	—	—	—	—	—	—	—	—	TSRST
Initial Value	0	0	0	0	0	0	0	0	0	0	0	0	0	0	0	0
R/W	R	R	R	R	R	R	R	R	R	R	R	R	R	R	R	R/W
Bit	15	14	13	12	11	10	9	8	7	6	5	4	3	2	1	0
	—	—	—	—	—	THLEIE	MEIE	DEIE	—	—	—	—	—	GSLPR	GMDC[1:0]	
Initial Value	0	0	0	0	0	0	0	0	0	0	0	0	0	1	0	1
R/W	R	R	R	R	R	R/W	R/W	R/W	R	R	R	R	R	R/W	R/W	R/W

Bit	Bit Name	Initial Value	R/W	Description
31 to 17	—	All 0	R	Reserved When read, the value after reset is returned. When writing to these bits, write the value after reset.
16	TSRST	0	R/W	Timestamp Counter Reset Setting the TSRST bit to 1 resets the timestamp counter. This bit is always read as 0.
15 to 11	—	All 0	R	Reserved When read, the value after reset is returned. When writing to these bits, write the value after reset.
10	THLEIE	0	R/W	Transmit History Buffer Overflow Interrupt Enable 0: Transmit history buffer overflow interrupt is disabled. 1: Transmit history buffer overflow interrupt is enabled.
9	MEIE	0	R/W	FIFO Message Lost Interrupt Enable 0: FIFO message lost interrupt is disabled. 1: FIFO message lost interrupt is enabled.
8	DEIE	0	R/W	DLC Error Interrupt Enable 0: DLC error interrupt is disabled. 1: DLC error interrupt is enabled.
7 to 3	—	All 0	R	Reserved When read, the value after reset is returned. When writing to these bits, write the value after reset.
2	GSLPR	1	R/W	Global Stop Mode 0: Other than global stop mode 1: Global stop mode
1, 0	GMDC[1:0]	01b	R/W	Global Mode Select b1 b0 0 0: Global operating mode 0 1: Global reset mode 1 0: Global test mode 1 1: Setting prohibited

TSRST Bit

This bit is used to reset the timestamp counter. When this bit is set to 1, the RSCANnGTSCregister is cleared to H'0000.

THLEIE Bit

When the THLEIE bit is set to 1 and the THLES flag in the RSCANnGERFL register is set to 1, an interrupt request is generated. Modify this bit only in global reset mode.

MEIE Bit

When the MEIE bit is set to 1 and the MES flag in the RSCANnGERFL register is set to 1, an interrupt request is generated. Modify this bit only in global reset mode.

DEIE Bit

When the DEIE bit is set to 1 and the DEF flag in the RSCANnGERFL register is set to 1, an interrupt request is generated. Modify this bit only in global reset mode.

GSLPR Bit

Setting this bit to 1 places the RSCAN module into global stop mode.

Clearing this bit to 0 makes the RSCAN module leave from global stop mode.

This bit should not be modified in global operating mode or global test mode.

GMDC[1:0] Bit

These bits are used to select the mode of entire RS-CANFD module (global operating mode, global reset mode, or global test mode). For details, see **Section 28.6.1, Global Modes**. Setting the GSLPR bit to 1 when in global reset mode places the RS-CANFD module into global stop mode.

28.3.4.3 RSCANnGSTS — Global Status Register

Access Size: RSCANnGSTS register can be read only in 32-bit units
 RSCANnGSTSL, RSCANnGSTSH registers can be read only in 16-bit units
 RSCANnGSTSLL, RSCANnGSTSLH, RSCANnGSTSHL, RSCANnGSTSHH registers can be read only in 8-bit units

Address(es): RSCANnGSTS: <RSCFDn_base> + H'008C
 RSCANnGSTSL: <RSCFDn_base> + H'008C, RSCANnGSTSH: <RSCFDn_base> + H'008E
 RSCANnGSTSLL: <RSCFDn_base> + H'008C, RSCANnGSTSLH: <RSCFDn_base> + 008D,
 RSCANnGSTSHL: <RSCFDn_base> + H'008E, RSCANnGSTSHH: <RSCFDn_base> + H'008F

Initial Value: H'0000 000D

Bit	31	30	29	28	27	26	25	24	23	22	21	20	19	18	17	16
	—	—	—	—	—	—	—	—	—	—	—	—	—	—	—	—
Initial Value	0	0	0	0	0	0	0	0	0	0	0	0	0	0	0	0
R/W	R	R	R	R	R	R	R	R	R	R	R	R	R	R	R	R
Bit	15	14	13	12	11	10	9	8	7	6	5	4	3	2	1	0
	—	—	—	—	—	—	—	—	—	—	—	—	GRAMINIT	GSLPSTS	GHLTSTS	GRSTSTS
Initial Value	0	0	0	0	0	0	0	0	0	0	0	0	1	1	0	1
R/W	R	R	R	R	R	R	R	R	R	R	R	R	R	R	R	R

Bit	Bit Name	Initial Value	R/W	Description
31 to 4	—	All 0	R	Reserved These bits are read as the value after reset. The write value should be the value after reset.
3	GRAMINIT	1	R	CAN RAM Initialization Status Flag 0: CAN RAM initialization is completed. 1: CAN RAM initialization is ongoing.
2	GSLPSTS	1	R	Global Stop Status Flag 0: Not in global stop mode 1: In global stop mode
1	GHLTSTS	0	R	Global Test Status Flag 0: Not in global test mode 1: In global test mode
0	GRSTSTS	1	R	Global Reset Status Flag 0: Not in global reset mode 1: In global reset mode

GRAMINIT Flag

This flag indicates the initialization status of the CAN RAM.

This flag is set to 1 after the MCU has been reset, and is cleared to 0 when CAN RAM initialization is completed.

GSLPSTS Flag

This flag is set to 1 when the CAN module has transitioned to global stop mode, and is cleared to 0 when the CAN module has returned from global stop mode.

GHLTSTS Flag

This flag is set to 1 when the CAN module has transitioned to global test mode, and is cleared to 0 when the CAN module has exited global test mode.

GRSTSTS Flag

This flag is set to 1 when the CAN module has transitioned to global reset mode, and is cleared to 0 when the CAN module has exited global reset mode. This flag remains 1 even when the CAN module has transitioned from global reset mode to global stop mode.

28.3.4.4 RSCANnGERFL — Global Error Flag Register

Access Size: RSCANnGERFL register can be read/written in 32-bit units
 RSCANnGERFLL, RSCANnGERFLH registers can be read/written in 16-bit units
 RSCANnGERFLLL, RSCANnGERFLLH, RSCANnGERFLHL, RSCANnGERFLHH registers can be read/written in 8-bit units

Address(es): RSCANnGERFL: <RSCFDn_base> + H'0090
 RSCANnGERFLL: <RSCFDn_base> + H'0090, RSCANnGERFLH: <RSCFDn_base> + H'0092
 RSCANnGERFLLL: <RSCFDn_base> + H'0090, RSCANnGERFLLH: <RSCFDn_base> + H'0091,
 RSCANnGERFLHL: <RSCFDn_base> + H'0092, RSCANnGERFLHH: <RSCFDn_base> + H'0093

Initial Value: H'0000 0000

Bit	31	30	29	28	27	26	25	24	23	22	21	20	19	18	17	16
	—	—	—	—	—	—	—	—	—	—	—	—	—	—	—	—
Initial Value	0	0	0	0	0	0	0	0	0	0	0	0	0	0	0	0
R/W	R	R	R	R	R	R	R	R	R	R	R	R	R	R	R	R
Bit	15	14	13	12	11	10	9	8	7	6	5	4	3	2	1	0
	—	—	—	—	—	—	—	—	—	—	—	—	—	THLES	MES	DEF
Initial Value	0	0	0	0	0	0	0	0	0	0	0	0	0	0	0	0
R/W	R	R	R	R	R	R	R	R	R	R	R	R	R	R	R	R/W*1

Bit	Bit Name	Initial Value	R/W	Description
31 to 14, 7, 6, 4, 3	—	All 0	R	Reserved These bits are read as the value after reset. The write value should be the value after reset.
13 to 8, 5	—	All 0	R	Reserved When read, an undefined value is returned. The write value should be the value after reset.
2	THLES	0	R	Transmit History Buffer Overflow Status Flag 0: No transmit history buffer overflow has occurred. 1: A transmit history buffer overflow has occurred.
1	MES	0	R	FIFO Message Lost Status Flag 0: No FIFO message lost error has occurred. 1: A FIFO message lost error has occurred.
0	DEF	0	R/W*1	DLC Error Flag 0: No DLC error has occurred. 1: A DLC error has occurred.

Note 1. The only effective value for writing to this flag bit is 0, which clears the bit. Otherwise writing to the bit results in retention of its state.

All flags in the RSCANnGERFL register are cleared to 0 in global reset mode.

THLES Flag

The THLES flag is set to 1 when any one of the THLELT flags in the RSCANnTHLSTSm register (m = 0, 1) is set to 1. This flag is cleared to 0 when the THLELT flags of all channels are set to 0.

MES Flag

The MES flag is set to 1 when any one of the RFMLT flags in the RSCANnRFSTSx register (x = 0 to 7) or the CFMLT flags in the RSCANnCFSTS_k register (k = 0 to 5) is set to 1.

This flag is cleared to 0 when all RFMLT flags and CFMLT flags are set to 0.

DEF Flag

The DEF flag is set to 1 when an error has been detected during the DLC check. The program can clear this flag by writing 0 to this bit.

NOTE

To clear the flags of the register to 0, the program must write 0 to the corresponding flag to be cleared. When writing 0, using store instruction, set the bit to be set to "0" to "0", and the bits not to be set to "0" to "1"

28.3.4.5 RSCANnGTSC — Global Timestamp Counter Register

Access Size: RSCANnGTSC register can be read only in 32-bit units.
RSCANnGTSC, RSCANnGTSC, RSCANnGTSC registers can be read only in 16-bit units.

Address(es): RSCANnGTSC: <RSCFDn_base> + H'0094
RSCANnGTSC: <RSCFDn_base> + H'0094, RSCANnGTSC: <RSCFDn_base> + H'0096

Initial Value: H'0000 0000

Bit	31	30	29	28	27	26	25	24	23	22	21	20	19	18	17	16
	—	—	—	—	—	—	—	—	—	—	—	—	—	—	—	—
Initial Value	0	0	0	0	0	0	0	0	0	0	0	0	0	0	0	0
R/W	R	R	R	R	R	R	R	R	R	R	R	R	R	R	R	R
Bit	15	14	13	12	11	10	9	8	7	6	5	4	3	2	1	0
	TS[15:0]															
Initial Value	0	0	0	0	0	0	0	0	0	0	0	0	0	0	0	0
R/W	R	R	R	R	R	R	R	R	R	R	R	R	R	R	R	R

Bit	Bit Name	Initial Value	R/W	Description
31 to 16	—	All 0	R	Reserved These bits are read as the value after reset.
15 to 0	TS[15:0]	All 0	R	Timestamp Value The timestamp counter value can be read. Counter Value: H'0000 to H'FFFF

TS[15:0] Bits

When the TS[15:0] bits are read, the read value shows the timestamp counter (16-bit free-running counter) value at that time. When the SOF is detected, the TS[15:0] value is captured and later stored in the receive buffer or the FIFO buffer. Furthermore, while the TMTSCE bit in the RSCANnGCFG register is 1, the TS[15:0] value is stored in the transmit history buffer. The timestamp counter is initialized in global reset mode.

The timestamp counter start timing and stop timing depend on the count source.

- When the TSSS bit in the GRSCANnGCFG register is 0 (pclk):
The timestamp counter starts counting when the RSCAN module has transitioned to global operating mode. This counter stops counting when the RSCAN module has transitioned to global stop mode or global test mode.
- When the TSSS bit is 1 (CANm bit time clock):
The timestamp counter starts counting when the corresponding channel has transitioned to channel communication mode.
This counter stops counting when the corresponding channel has transitioned to channel reset mode or channel halt mode.

28.3.4.6 RSCANnGTINTSTS0 — Global TX Interrupt Status Register 0

Access Size: RSCANnGTINTSTS0 register can be read only in 32-bit units
 RSCANnGTINTSTS0L, RSCANnGTINTSTS0H registers can be read only in 16-bit units
 RSCANnGTINTSTS0LL, RSCANnGTINTSTS0LH, RSCANnGTINTSTS0HL, RSCANnGTINTSTS0HH registers can be read only in 8-bit units

Address(es): RSCANnGTINTSTS0: <RSCFDn_base> + H'0460
 RSCANnGTINTSTS0L: <RSCFDn_base> + H'0460, RSCANnGTINTSTS0H: <RSCFDn_base> + H'0462
 RSCANnGTINTSTS0LL: <RSCFDn_base> + H'0460, RSCANnGTINTSTS0LH: <RSCFDn_base> + H'0461,
 RSCANnGTINTSTS0HL: <RSCFDn_base> + H'0462, RSCANnGTINTSTS0HH: <RSCFDn_base> + H'0463

Initial Value: H'0000 0000

Bit	31	30	29	28	27	26	25	24	23	22	21	20	19	18	17	16
	—	—	—	—	—	—	—	—	—	—	—	—	—	—	—	—
Initial Value	0	0	0	0	0	0	0	0	0	0	0	0	0	0	0	0
R/W	R	R	R	R	R	R	R	R	R	R	R	R	R	R	R	R
Bit	15	14	13	12	11	10	9	8	7	6	5	4	3	2	1	0
	—	—	—	THIF1	CFTIF1	TQIF1	TAIF1	TSIF1	—	—	—	THIF0	CFTIF0	TQIF0	TAIF0	TSIF0
Initial Value	0	0	0	0	0	0	0	0	0	0	0	0	0	0	0	0
R/W	R	R	R	R ^{*1}	R ^{*1}	R ^{*1}	R ^{*1}	R ^{*1}	R	R	R	R ^{*1}	R ^{*1}	R ^{*1}	R ^{*1}	R ^{*1}

Bit	Bit Name	Initial Value	R/W	Description
31 to 13	—	All 0	R	Reserved These bits are read as the value after reset.
12	THIF1	0	R ^{*1}	Channel 1 Transmit History Interrupt Status Flag 0: Transmit history interrupt is not requested. 1: Transmit history interrupt is requested.
11	CFTIF1	0	R ^{*1}	Channel 1 Transmit/receive FIFO Transmit Interrupt Status Flag 0: Transmit/receive FIFO transmit interrupt is not requested. 1: Transmit/receive FIFO transmit interrupt is requested.
10	TQIF1	0	R ^{*1}	Channel 1 Transmit Queue Interrupt Status Flag 0: Transmit queue interrupt is not requested. 1: Transmit queue interrupt is requested.
9	TAIF1	0	R ^{*1}	Channel 1 Transmit Buffer Abort Interrupt Status Flag 0: Transmit buffer abort interrupt is not requested. 1: Transmit buffer abort interrupt is requested.
8	TSIF1	0	R ^{*1}	Channel 1 Transmit Buffer Interrupt Status Flag 0: Transmit buffer transmit complete interrupt is not requested. 1: Transmit buffer transmit complete interrupt is requested.
7 to 5	—	All 0	R	Reserved These bits are read as the value after reset.
4	THIF0	0	R ^{*1}	Channel 0 Transmit History Interrupt Status Flag 0: Transmit history interrupt is not requested. 1: Transmit history interrupt is requested.
3	CFTIF0	0	R ^{*1}	Channel 0 Transmit/receive FIFO Transmit Interrupt Status Flag 0: Transmit/receive FIFO transmit interrupt is not requested. 1: Transmit/receive FIFO transmit interrupt is requested.
2	TQIF0	0	R ^{*1}	Channel 0 Transmit Queue Interrupt Status Flag 0: Transmit queue interrupt is not requested. 1: Transmit queue interrupt is requested.

Bit	Bit Name	Initial Value	R/W	Description
1	TAIF0	0	R*1	Channel 0 Transmit Buffer Abort Interrupt Status Flag 0: Transmit buffer abort interrupt is not requested. 1: Transmit buffer abort interrupt is requested.
0	TSIF0	0	R*1	Channel 0 Transmit Buffer Interrupt Status Flag 0: Transmit buffer transmit complete interrupt is not requested. 1: Transmit buffer transmit complete interrupt is requested.

Note 1. This bit is automatically cleared in the global reset or channel reset mode.

TSIFm Bits

The TSIFm bit is set to 1 when the TMIEp bit in the RSCANnTMIECy register is set to 1 (transmit buffer interrupt enabled) and the TMTRF[1:0] flags in the RSCANnTMSTSp register are set to 10b (transmit completed without abort request) or 11b (transmit completed with abort request).

When the TMTRF[1:0] flags are cleared to 00b under the condition that the TSIFm bit can be set to 1, this flag is cleared to 0. In addition, clearing the TMIEp bit to 0 also clears this flag to 0.

TAIFm Bits

The TAIFm bit is set to 1 when the TAIE bit in the RSCANnCmCTR register is 1 (transmit abort interrupt enabled) and the TMTRF[1:0] flags in the RSCANnTMSTSp register are set to 01b (transmit abort completed).

This flag is cleared to 0 when the TMTRF[1:0] flags are cleared to 00b after the transmit abort is completed.

TQIFm Bits

When the TXQIE bit in the RSCANnTXQCCm register is set to 1 (transmit queue interrupt enabled) and the TXQIF bit in the RSCANnTXQSTSm register is set to 1 (transmit queue interrupt request), the TQIFm bit is set to 1.

When the TXQIF bit (transmit queue interrupt request) in the RSCANnTXQSTSm register is cleared to 0, this bit is cleared to 0. This flag is also cleared to 0 when the TXQIE bit is cleared to 0.

CFTIFm Bits

When the CFTXIE bit in the RSCANnCFCCk register is set to 1 (transmit/receive FIFO transmit interrupt enabled) and the CFTXIF bit in the RSCANnCFSTSk register is set to 1 (transmit/receive FIFO transmit interrupt request), the CFTIFm bit is set to 1.

When the CFTXIF bit is cleared to 0 under the conditions that the CFTIFm bit can be set to 1, this bit is cleared to 0. This flag is also cleared to 0 when the CFTXIE bit is cleared to 0.

THIFm Bits

When the THLIE bit in the RSCANnTHLCCm register is set to 1 (transmit history interrupt enabled) and the THLIF bit in the RSCANnTHLSTSm register is set to 1 (transmit history interrupt request), the THIFm bit is set to 1.

When the THLIF bit in the RSCANnTHLSTSm register is cleared to 0, this bit is cleared to 0. This flag is also cleared to 0 when the THLIE bit is cleared to 0.

28.3.4.7 RSCANnGFDCFG — Global FD configuration register

Access Size: RSCANnGFDCFG register can be read/written in 32-bit unit
 RSCANnGFDCFGL and RSCANnGFDCFGH registers can be read/written in 16-bit unit
 RSCANnGFDCFGLL, RSCANnGFDCFGLH, RSCANnGFDCFGHL, RSCANnGFDCFGHH registers can be read/written in 8-bit unit

Address(es): RSCANnGFDCFG: <RSCFDn_base> + H'0474
 RSCANnGFDCFG L: <RSCFDn_base> + H'0474, RSCANnGFDCFG H: <RSCFDn_base> + H'0476
 RSCANnGFDCFG LL: <RSCFDn_base> + H'0474, RSCANnGFDCFG LH: <RSCFDn_base> + H'0475,
 RSCANnGFDCFG HL: <RSCFDn_base> + H'0476, RSCANnGFDCFG HH: <RSCFDn_base> + H'0477

Initial Value: H'0000 0000

Bit	31	30	29	28	27	26	25	24	23	22	21	20	19	18	17	16
	—	—	—	—	—	—	—	—	—	—	—	—	—	—	—	—
Initial Value	0	0	0	0	0	0	0	0	0	0	0	0	0	0	0	0
	R/W	R/W	R/W	R/W	R/W	R/W	R/W	R/W	R/W	R/W	R/W	R/W	R/W	R/W	R/W	R/W
Bit	15	14	13	12	11	10	9	8	7	6	5	4	3	2	1	0
	—	—	—	—	—	—	TSCCFG[1:0]		—	—	—	—	—	—	—	—
Initial Value	0	0	0	0	0	0	0	0	0	0	0	0	0	0	0	0
	R/W	R/W	R/W	R/W	R/W	R/W	R/W	R/W	R/W	R/W	R/W	R/W	R/W	R/W	R/W	R/W

Bit	Bit Name	Initial Value	R/W	Description
31 to 10	—	All 0	R/W	Reserved These bits are read as the value after reset. The write value should be the value after reset.
9, 8	TSCCFG[1:0]	All 0	R/W	Time-stamp capture setting bit b9 b8 0 0: Captured at a sample point in the SOF bit. 0 1: Captured when a valid frame has been transmitted/received. 1 0: Setting prohibited 1 1: Setting prohibited
7 to 1	—	All 0	R/W	Reserved These bits are read as the value after reset. The write value should be the value after reset.
0	—	0	R/W	Reserved When read, an undefined value is returned. The write value should be the value after reset.

TSCCFG bit

Select a point where a time-stamp value is captured. Modify this bit only in global reset mode.

28.3.5 Details of Receive Rule-related Registers

28.3.5.1 RSCANnGAFLECTR — Receive Rule Entry Control Register

Access Size: RSCANnGAFLECTR register can be read/written in 32-bit units
 RSCANnGAFLECTRL, RSCANnGAFLECTRH registers can be read/written in 16-bit units
 RSCANnGAFLECTRLL, RSCANnGAFLECTRLH, RSCANnGAFLECTRHL, RSCANnGAFLECTRHH registers can be read/written in 8-bit units

Address(es): RSCANnGAFLECTR: <RSCFDn_base> + H'0098
 RSCANnGAFLECTRL: <RSCFDn_base> + H'0098, RSCANnGAFLECTRH: <RSCFDn_base> + H'009A
 RSCANnGAFLECTRLL: <RSCFDn_base> + H'0098, RSCANnGAFLECTRLH: <RSCFDn_base> + H'0099,
 RSCANnGAFLECTRHL: <RSCFDn_base> + H'009A, RSCANnGAFLECTRHH: <RSCFDn_base> + H'009B

Initial Value: H'0000 0000

Bit	31	30	29	28	27	26	25	24	23	22	21	20	19	18	17	16
	—	—	—	—	—	—	—	—	—	—	—	—	—	—	—	—
Initial Value	0	0	0	0	0	0	0	0	0	0	0	0	0	0	0	0
R/W	R	R	R	R	R	R	R	R	R	R	R	R	R	R	R	R
Bit	15	14	13	12	11	10	9	8	7	6	5	4	3	2	1	0
	—	—	—	—	—	—	—	AFLDAE	—	—	—	AFLPN[4:0]				
Initial Value	0	0	0	0	0	0	0	0	0	0	0	0	0	0	0	0
R/W	R	R	R	R	R	R	R	R/W	R	R	R	R/W	R/W	R/W	R/W	R/W

Bit	Bit Name	Initial Value	R/W	Description
31 to 9	—	All 0	R	Reserved These bits are read as the value after reset. The write value should be the value after reset.
8	AFLDAE	0	R/W	Receive Rule Table Write Enable 0: Receive rule table write is disabled. 1: Receive rule table write is enabled.
7 to 5	—	All 0	R	Reserved These bits are read as the value after reset. The write value should be the value after reset.
4 to 0	AFLPN[4:0]	All 0	R/W	Receive Rule Table Page Number Configuration A page number can be selected from a range of page 0 (00000b) to page 7 (00111b).

AFLDAE Bit

Setting this bit to 0 disables the write to the receive rule table. After writes to the receive rule table are completed, set this bit to 0 to disable the write to the table. The receive rule table can be read regardless of the value of this bit.

Set the AFLDAE bit to 1 only in global reset mode.

AFLPN[4:0] Bits

These bits are used to set the page number of the receive rule table. Sixteen receive rules can be set per page. Set these bits to a value within the range of 00000b to 00111b.

28.3.5.2 RSCANnGAFLCFG0 — Receive Rule Configuration Register 0

Access Size: RSCANnGAFLCFG0 register can be read/written in 32-bit units
 RSCANnGAFLCFG0L, RSCANnGAFLCFG0H registers can be read/written in 16-bit units
 RSCANnGAFLCFG0LL, RSCANnGAFLCFG0LH, RSCANnGAFLCFG0HL, RSCANnGAFLCFG0HH registers can be read/written in 8-bit units

Address(es): RSCANnGAFLCFG0: <RSCFDn_base> + H'009C
 RSCANnGAFLCFG0L: <RSCFDn_base> + H'009C, RSCANnGAFLCFG0H: <RSCFDn_base> + H'009E
 RSCANnGAFLCFG0LL: <RSCFDn_base> + H'009C, RSCANnGAFLCFG0LH: <RSCFDn_base> + H'009D,
 RSCANnGAFLCFG0HL: <RSCFDn_base> + H'009E, RSCANnGAFLCFG0HH: <RSCFDn_base> + H'009F

Initial Value: H'0000 0000

Bit	31	30	29	28	27	26	25	24	23	22	21	20	19	18	17	16
	RNC0[7:0]								RNC1[7:0]							
Initial Value	0	0	0	0	0	0	0	0	0	0	0	0	0	0	0	0
R/W	R/W	R/W	R/W	R/W	R/W	R/W	R/W	R/W	R/W	R/W	R/W	R/W	R/W	R/W	R/W	R/W
Bit	15	14	13	12	11	10	9	8	7	6	5	4	3	2	1	0
	—	—	—	—	—	—	—	—	—	—	—	—	—	—	—	—
Initial Value	0	0	0	0	0	0	0	0	0	0	0	0	0	0	0	0
R/W	R	R	R	R	R	R	R	R	R	R	R	R	R	R	R	R

Bit	Bit Name	Initial Value	R/W	Description
31 to 24	RNC0[7:0]	All 0	R/W	Number of Rules for Channel 0 Set the number of receive rules exclusively used for channel 0.
23 to 16	RNC1[7:0]	All 0	R/W	Number of Rules for Channel 1 Set the number of receive rules exclusively used for channel 1.
15 to 0	—	All 0	R	Reserved These bits are read as the value after reset. The write value should be the value after reset.

Modify the RSCANnGAFLCFG0 register only in global reset mode.

Up to 64 × (number of channels) rules can be registered in the receive rule table as the entire unit. The number of receive rules per channel should meet the following conditions.

- The maximum number of rules per channel is 128.
- The total of the number of rules allocated to each channel is not larger than the number of rules that can be registered in the entire unit.

RNC0[7:0] Bits

These bits are used to set the number of rules to be registered in the channel 0 receive rule table. Set these bits to a value within the range of H'00 to H'80.

RNC1[7:0] Bits

These bits are used to set the number of rules to be registered in the channel 1 receive rule table. Set these bits to a value within the range of H'00 to H'80.

28.3.5.3 RSCANnGAFLIDj — Receive Rule ID Register (j = 0 to 15)

Access Size: RSCANnGAFLIDj register can be read/written in 32-bit units
 RSCANnGAFLIDjL, RSCANnGAFLIDjH registers can be read/written in 16-bit units
 RSCANnGAFLIDjLL, RSCANnGAFLIDjLH, RSCANnGAFLIDjHL, RSCANnGAFLIDjHH registers can be read/written in 8-bit units

Address(es): RSCANnGAFLIDj: <RSCFDn_base> + H'0500 + (H'10 × j)
 RSCANnGAFLIDjL: <RSCFDn_base> + H'0500 + (H'10 × j),
 RSCANnGAFLIDjH: <RSCFDn_base> + H'0502 + (H'10 × j)
 RSCANnGAFLIDjLL: <RSCFDn_base> + H'0500 + (H'10 × j),
 RSCANnGAFLIDjLH: <RSCFDn_base> + H'0501 + (H'10 × j),
 RSCANnGAFLIDjHL: <RSCFDn_base> + H'0502 + (H'10 × j),
 RSCANnGAFLIDjHH: <RSCFDn_base> + H'0503 + (H'10 × j)

Initial Value: H'0000 0000

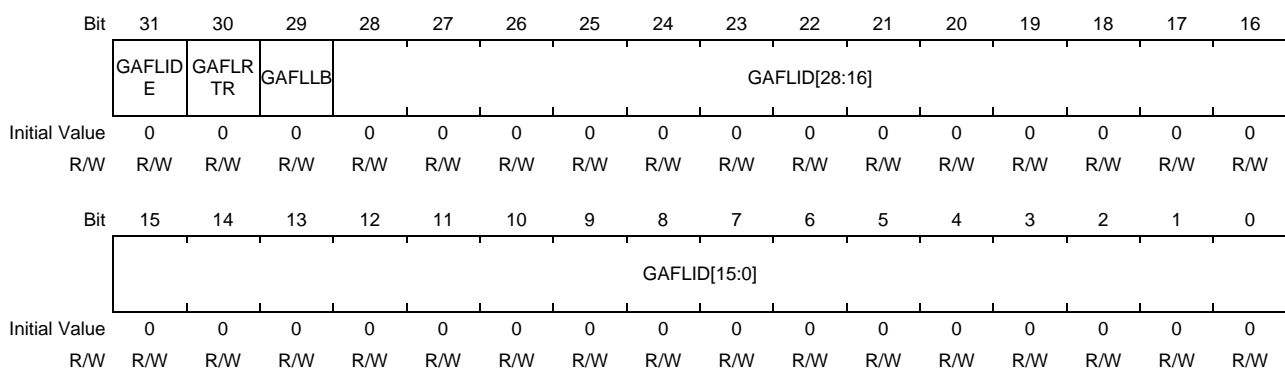

Bit	Bit Name	Initial Value	R/W	Description
31	GAFLIDE	0	R/W	IDE Select 0: Standard ID 1: Extended ID
30	GAFLRTR	0	R/W	RTR Select 0: Data frame 1: Remote frame
29	GAFLLB	0	R/W	Receive Rule Target Message Select 0: When a message transmitted from another CAN node is received 1: When the own transmitted message is received
28 to 0	GAFLID[28:0]	All 0	R/W	ID Set the ID of the receive rule. For the standard ID, set the ID in bits b10 to b0 and set bits b28 to b11 to 0.

Modify the RSCANnGAFLIDj register when the AFLDAE bit in the RSCANnGAFLECTR register is set to 1 (receive rule table write is enabled) in global reset mode.

GAFLIDE Bit

This bit is used to select the ID format (standard ID or extended ID) of the receive rule. This bit is compared with the IDE bit in the received message during the acceptance filter processing.

GAFLRTR Bit

This bit is used to select the frame format (data frame or remote frame) of the receive rule. This bit is compared with the RTR bit in the received message during the acceptance filter processing.

GAFLB Bit

When this bit is set to 0, data processing using the receive rule is performed when receiving messages transmitted from another CAN node.

When this bit is set to 1 when the mirror function is used, data processing using the receive rule is performed when the CAN node is receiving its own transmitted messages.

GAFLID[28:0] Bits

These bits are used to set the ID field of the receive rule. The ID value set by these bits is compared with the ID of the received message during the acceptance filter processing.

28.3.5.4 RSCANnGAFLMj — Receive Rule Mask Register (j = 0 to 15)

Access Size: RSCANnGAFLMj register can be read/written in 32-bit units
 RSCANnGAFLMjL, RSCANnGAFLMjH registers can be read/written in 16-bit units
 RSCANnGAFLMjLL, RSCANnGAFLMjLH, RSCANnGAFLMjHL, RSCANnGAFLMjHH registers can be read/written in 8-bit units

Address(es): RSCANnGAFLMj: <RSCFDn_base> + H'0504 + (H'10 × j)
 RSCANnGAFLMjL: <RSCFDn_base> + H'0504 + (H'10 × j),
 RSCANnGAFLMjH: <RSCFDn_base> + H'0506 + (H'10 × j)
 RSCANnGAFLMjLL: <RSCFDn_base> + H'0504 + (H'10 × j),
 RSCANnGAFLMjLH: <RSCFDn_base> + H'0505 + (H'10 × j),
 RSCANnGAFLMjHL: <RSCFDn_base> + H'0506 + (H'10 × j),
 RSCANnGAFLMjHH: <RSCFDn_base> + H'0507 + (H'10 × j)

Initial Value: H'0000 0000

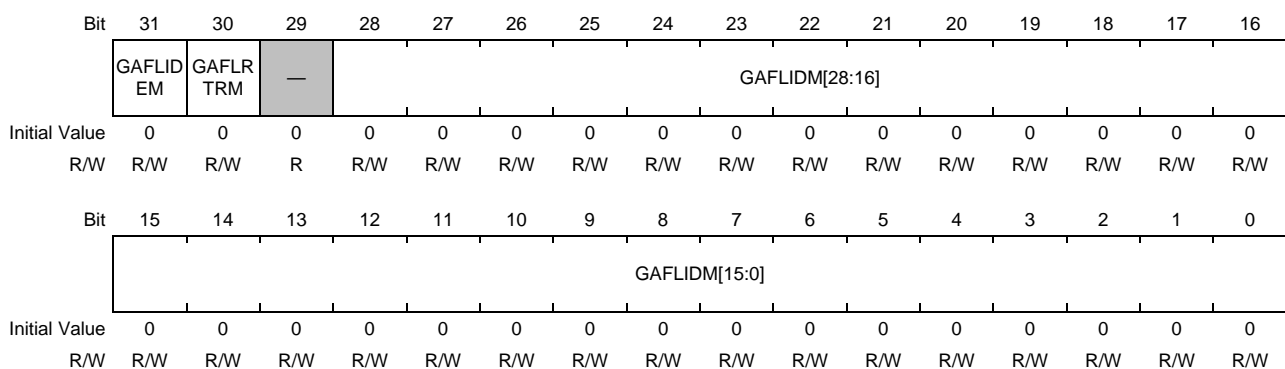

Bit	Bit Name	Initial Value	R/W	Description
31	GAFLIDEM	R/W	R/W	IDE Mask 0: The IDE bit is not compared. 1: The IDE bit is compared.
30	GAFLRTRM	R/W	R/W	RTR Mask 0: The RTR bit is not compared. 1: The RTR bit is compared
29	—	0	R	Reserved These bits are read as the value after reset. The write value should be the value after reset.
28 to 0	GAFLIDM [28:0]	All 0	R/W	ID Mask 0: The corresponding ID bit is not compared. 1: The corresponding ID bit is compared.

Modify the RSCANnGAFLMj register when the AFLDAE bit in the RSCANnGAFLECTR register is set to 1 (receive rule table write is enabled) in global reset mode.

GAFLIDEM Bit

When this bit is set to 1, filter processing is performed only for messages of the ID format specified by the GAFLIDE bit in the RSCANnGAFLIDj register.

When this bit is cleared to 0, the IDs of all the receive messages and the specified IDs are regarded as matched. To set the GAFLIDEM bit to 0, set the GAFLIDM[28:0] bits to all 0 at the same time.

GAFLRTRM Bit

This bit is used to mask the RTR bit of the receive rule.

GAFLIDM[28:0] Bits

These bits are used to mask the corresponding ID bit of the receive rule.

28.3.5.5 RSCANnGAFLP0_j — Receive Rule Pointer 0 Register (j = 0 to 15)

Access Size: RSCANnGAFLP0_j register can be read/written in 32-bit units
 RSCANnGAFLP0_jL, RSCANnGAFLP0_jH registers can be read/written in 16-bit units
 RSCANnGAFLP0_jLL, RSCANnGAFLP0_jLH, RSCANnGAFLP0_jHL, RSCANnGAFLP0_jHH registers can be read/written in 8-bit units

Address(es): RSCANnGAFLP0_j: <RSCFDn_base> + H'0508 + (H'10 × j)
 RSCANnGAFLP0_jL: <RSCFDn_base> + H'0508 + (H'10 × j),
 RSCANnGAFLP0_jH: <RSCFDn_base> + H'050A + (H'10 × j)
 RSCANnGAFLP0_jLL: <RSCFDn_base> + H'0508 + (H'10 × j),
 RSCANnGAFLP0_jLH: <RSCFDn_base> + H'0509 + (H'10 × j),
 RSCANnGAFLP0_jHL: <RSCFDn_base> + H'050A + (H'10 × j),
 RSCANnGAFLP0_jHH: <RSCFDn_base> + H'050B + (H'10 × j)

Initial Value: H'0000 0000

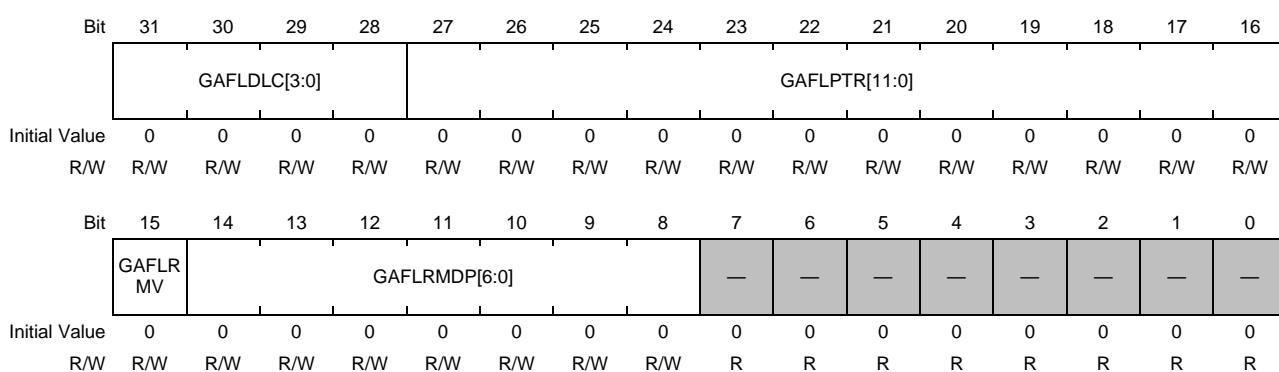

Bit	Bit Name	Initial Value	R/W	Description
31 to 28	GAFLDLC [3:0]	All 0	R/W	Receive Rule DLC b31 b30 b29 b28 0 0 0 0: DLC check is disabled. 0 0 0 1: 1 data byte 0 0 1 0: 2 data bytes 0 0 1 1: 3 data bytes 0 1 0 0: 4 data bytes 0 1 0 1: 5 data bytes 0 1 1 0: 6 data bytes 0 1 1 1: 7 data bytes 1 X X X: 8 data bytes
27 to 16	GAFLPTR [11:0]	All 0	R/W	Receive Rule Label Set the 12-bit label information.
15	GAFLRMV	0	R/W	Receive Buffer Enable 0: No receive buffer is used. 1: A receive buffer is used.
14 to 8	GAFLRMDP [6:0]	All 0	R/W	Receive Buffer Number Select Set the receive buffer number to store receive messages.
7 to 0	—	All 0	R	Reserved These bits are read as the value after reset. The write value should be the value after reset.

Modify the RSCANnGAFLP0_j register when the AFLDAE bit in the RSCANnGAFLECTR register is set to 1 (receive rule table write is enabled) in global reset mode.

GAFLDLC[3:0] Bits

These bits are used to set the minimum data length necessary for receiving messages. If the data length of a message that is being filtered is equal to or larger than the value set by the GAFLDLC[3:0] bits, the message passes the DLC check. Setting these bits to 0000b disables the DLC check function allowing messages with any data length to pass the DLC check.

GAFLPTR[11:0] Bits

These bits are used to set a 12-bit label to be attached to messages that have passed through the filter. A label is attached when a message is stored in the receive buffer or the FIFO buffer.

GAFLRMV Bit

When this bit is set to 1, receive messages that have passed through the filter are stored in the receive buffer selected by the GAFLRMDP[6:0] bits.

GAFLRMDP[6:0] Bits

These bits are used to select the number of the receive buffer that stores receive messages that have passed through the filter when the GAFLRMV bit is set to 1. Set these bits to a value smaller than the value set by the NRXMB[7:0] bits in the RSCANnRMNB register.

28.3.5.6 RSCANnGAFLP1_j — Receive Rule Pointer 0 Register (j = 0 to 15)

Access Size: RSCANnGAFLP1_j register can be read/written in 32-bit units
 RSCANnGAFLP1_jL, RSCANnGAFLP1_jH registers can be read/written in 16-bit units
 RSCANnGAFLP1_jLL, RSCANnGAFLP1_jLH, RSCANnGAFLP1_jHL, RSCANnGAFLP1_jHH registers can be read/written in 8-bit units

Address(es): RSCANnGAFLP1_j: <RSCFDn_base> + H'050C + (H'10 × j)
 RSCANnGAFLP1_jL: <RSCFDn_base> + H'050C + (H'10 × j),
 RSCANnGAFLP1_jH: <RSCFDn_base> + H'050E + (H'10 × j)
 RSCANnGAFLP1_jLL: <RSCFDn_base> + H'050C + (H'10 × j),
 RSCANnGAFLP1_jLH: <RSCFDn_base> + H'050D + (H'10 × j),
 RSCANnGAFLP1_jHL: <RSCFDn_base> + H'050E + (H'10 × j),
 RSCANnGAFLP1_jHH: <RSCFDn_base> + H'050F + (H'10 × j)

Initial Value: H'0000 0000

Bit	31	30	29	28	27	26	25	24	23	22	21	20	19	18	17	16
	—	—	—	—	—	—	—	—	—	—	—	—	—	—	—	—
Initial Value	0	0	0	0	0	0	0	0	0	0	0	0	0	0	0	0
R/W	R	R	R	R	R	R	R	R	R	R	R	R	R	R	R	R
Bit	15	14	13	12	11	10	9	8	7	6	5	4	3	2	1	0
	—	—	GAFLFDP[13:0]													
Initial Value	0	0	0	0	0	0	0	0	0	0	0	0	0	0	0	0
R/W	R	R	R/W	R/W	R/W	R/W	R/W	R/W	R/W	R/W	R/W	R/W	R/W	R/W	R/W	R/W

Bit	Bit Name	Initial Value	R/W	Description
31 to 14	—	All 0	R	Reserved These bits are read as the value after reset. The write value should be the value after reset.
13 to 8	GAFLFDP [13:8]	All 0	R/W	Transmit/Receive FIFO Buffer k Select (Bit position –8 = target transmit/receive FIFO buffer number k) 0: Transmit/receive FIFO buffer is not selected. 1: Transmit/receive FIFO buffer is selected.
7 to 0	GAFLFDP [7:0]	All 0	R/W	Receive FIFO Buffer x Select (Bit position = target receive FIFO buffer number x) 0: Receive FIFO buffer is not selected. 1: Receive FIFO buffer is selected.

Modify the RSCANnGAFLP1_j register when the AFLDAE bit in the RSCANnGAFLECTR register is set to 1 (receive rule table write is enabled) in global reset mode.

GAFLFDP[13:0] Bits

These bits are used to specify FIFO buffers that store receive messages that have passed through the filter. Up to eight FIFO buffers are selectable. However, when the GAFLRMV bit in the RSCANnGAFLP0_j register is set to 1 (a message is stored in the receive buffer), up to seven FIFO buffers can be selected. Only receive FIFO buffers and the transmit/ receive FIFO buffer for which the CFM[1:0] bits in the RSCANnCFCK register are set to 00b (receive mode) or 10b (gateway mode) are selectable.

28.3.6 Details of Receive Buffer-related Registers

28.3.6.1 RSCANnRMNB — Receive Buffer Number Register

Access Size: RSCANnRMNB register can be read/written in 32-bit units
 RSCANnRMNBL, RSCANnRMNBH registers can be read/written in 16-bit units
 RSCANnRMNBLL, RSCANnRMNBHL, RSCANnRMNBHL, RSCANnRMNBHH registers can be read/written in 8-bit units

Address(es): RSCANnRMNB: <RSCFDn_base> + H'00A4
 RSCANnRMNBL: <RSCFDn_base> + H'00A4, RSCANnRMNBH: <RSCFDn_base> + H'00A6
 RSCANnRMNBLL: <RSCFDn_base> + H'00A4, RSCANnRMNBHL: <RSCFDn_base> + H'00A5,
 RSCANnRMNBHL: <RSCFDn_base> + H'00A6, RSCANnRMNBHH: <RSCFDn_base> + H'00A7

Initial Value: H'0000 0000

Bit	31	30	29	28	27	26	25	24	23	22	21	20	19	18	17	16
	—	—	—	—	—	—	—	—	—	—	—	—	—	—	—	—
Initial Value	0	0	0	0	0	0	0	0	0	0	0	0	0	0	0	0
R/W	R	R	R	R	R	R	R	R	R	R	R	R	R	R	R	R
Bit	15	14	13	12	11	10	9	8	7	6	5	4	3	2	1	0
	—	—	—	—	—	—	—	—	NRXMB[7:0]							
Initial Value	0	0	0	0	0	0	0	0	0	0	0	0	0	0	0	0
R/W	R	R	R	R	R	R	R	R	R/W	R/W	R/W	R/W	R/W	R/W	R/W	R/W

Bit	Bit Name	Initial Value	R/W	Description
31 to 8	—	All 0	R	Reserved These bits are read as the value after reset. The write value should be the value after reset.
7 to 0	NRXMB[7:0]	All 0	R/W	Receive Buffer Number Configuration Set the number of receive buffers. Set a value of 0 to 32.

Modify the RSCANnRMNB register only in global reset mode.

NRXMB[7:0] Bits

These bits are used to set the total number of receive buffers of the RS-CANFD module. The maximum value is $16 \times$ (number of channels).

Setting these bits all to 0 makes receive buffers unavailable.

28.3.6.2 RSCANnRMNDy — Receive Buffer New Data Register (y = 0)

Access Size: RSCANnRMNDy register can be read/written in 32-bit units
 RSCANnRMNDyL, RSCANnRMNDyH registers can be read/written in 16-bit units
 RSCANnRMNDyLL, RSCANnRMNDyLH, RSCANnRMNDyHL, RSCANnRMNDyHH registers can be read/written in 8-bit units

Address(es): RSCANnRMNDy: <RSCFDn_base> + H'00A8 + (H'04 × y)
 RSCANnRMNDyL: <RSCFDn_base> + H'00A8 + (H'04 × y),
 RSCANnRMNDyH: <RSCFDn_base> + H'00AA + (H'04 × y)
 RSCANnRMNDyLL: <RSCFDn_base> + H'00A8 + (H'04 × y),
 RSCANnRMNDyLH: <RSCFDn_base> + H'00A9 + (H'04 × y),
 RSCANnRMNDyHL: <RSCFDn_base> + H'00AA + (H'04 × y),
 RSCANnRMNDyHH: <RSCFDn_base> + H'00AB + (H'04 × y)

Initial Value: H'0000 0000

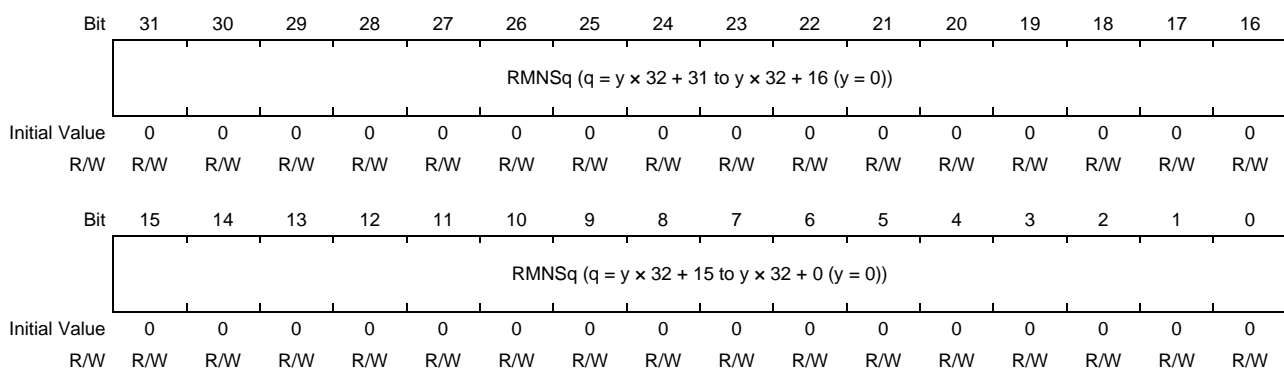

Bit	Bit Name	Initial Value	R/W	Description
31 to 16	RMNSq	All 0	R/W	Receive Buffer Receive Complete Flag q (q = y × 32 + 31 to y × 32 + 16) 0: There is no new message in receive buffer q. 1: There is a new message in receive buffer q.
15 to 0	RMNSq	All 0	R/W	Receive Buffer Receive Complete Flag q (q = y × 32 + 15 to y × 32 + 0) 0: There is no new message in receive buffer q. 1: There is a new message in receive buffer q.

Write 0 to the RSCANnRMNDy register in global operating mode or global test mode.

RMNSq Flags (q = 0 to 31)

Each RMNSq flag is set to 1 when the processing for storing a message in the corresponding receive buffer starts.

To clear a flag to 0, the program must write 0 to the flag. Use a store instruction to write “0” to the flag and “1” to other flags. These bits cannot be set to 0 while a message is being stored. It takes ten clock cycles of pclk to store a message. These flags are cleared to 0 in global reset mode.

28.3.6.3 RSCANnRMIDq — Receive Buffer ID Register (q = 0 to 31)

Access Size: RSCANnRMIDq register can be read only in 32-bit units
 RSCFDnRMIDqRSCANnRMIDqL, RSCFDnRMIDqRSCANnRMIDqH registers can be read only in 16-bit units
 RSCFDnRMIDqRSCANnRMIDqLL, RSCFDnRMIDqRSCANnRMIDqLH, RSCFDnRMIDqRSCANnRMIDqHL,
 RSCFDnRMIDqRSCANnRMIDqHH registers can be read only in 8-bit units

Address(es): RSCANnRMIDq: <RSCFDn_base> + H'0600 + (H'10 × q)
 RSCANnRMIDqL: <RSCFDn_base> + H'0600 + (H'10 × q),
 RSCANnRMIDqH: <RSCFDn_base> + H'0602 + (H'10 × q)
 RSCANnRMIDqLL: <RSCFDn_base> + H'0600 + (H'10 × q),
 RSCANnRMIDqLH: <RSCFDn_base> + H'0601 + (H'10 × q),
 RSCANnRMIDqHL: <RSCFDn_base> + H'0602 + (H'10 × q),
 RSCANnRMIDqHH: <RSCFDn_base> + H'0603 + (H'10 × q)

Initial Value: H'0000 0000

Bit	31	30	29	28	27	26	25	24	23	22	21	20	19	18	17	16
	RMIDE	RMRTR	—	RMID[28:16]												
Initial Value	0	0	0	0	0	0	0	0	0	0	0	0	0	0	0	0
R/W	R	R	R	R	R	R	R	R	R	R	R	R	R	R	R	R
Bit	15	14	13	12	11	10	9	8	7	6	5	4	3	2	1	0
	RMID[15:0]															
Initial Value	0	0	0	0	0	0	0	0	0	0	0	0	0	0	0	0
R/W	R	R	R	R	R	R	R	R	R	R	R	R	R	R	R	R

Bit	Bit Name	Initial Value	R/W	Description
31	RMIDE	0	R	Receive Buffer IDE 0: Standard ID 1: Extended ID
30	RMRTR	0	R	Receive Buffer RTR 0: Data frame 1: Remote frame
29	—	0	R	Reserved This bit is read as the value after reset.
28 to 0	RMID[28:0]	All 0	R	Receive Buffer ID Data These bits contain the standard ID or extended ID of the received message. Read bits b10 to b0 for standard ID. Bits b28 to b11 are read as 0.

RMIDE Bit

This bit indicates the ID format (standard ID or extended ID) of the message stored in the receive buffer

RMRTR Bit

This bit indicates the frame format (data frame or remote frame) of the message stored in the receive buffer.

RMID[28:0] Bits

These bits contain the ID of the message stored in the receive buffer.

28.3.6.4 RSCANnRMPTRq — Receive Buffer Pointer Register (q = 0 to 31)

- Access Size:** RSCANnRMPTRq register can be read only in 32-bit units
 RSCFDnRMPTRqRSCANnRMPTRqL, RSCFDnRMPTRqRSCANnRMPTRqH registers can be read only in 16-bit units
 RSCFDnRMPTRqRSCANnRMPTRqLL, RSCFDnRMPTRqRSCANnRMPTRqLH,
 RSCFDnRMPTRqRSCANnRMPTRqHL, RSCFDnRMPTRqRSCANnRMPTRqHH registers can be read only in 8-bit units
- Address(es):** RSCANnRMPTRq: <RSCFDn_base> + H'0604 + (H'10 × q)
 RSCANnRMPTRqL: <RSCFDn_base> + H'0604 + (H'10 × q),
 RSCANnRMPTRqH: <RSCFDn_base> + H'0606 + (H'10 × q)
 RSCANnRMPTRqLL: <RSCFDn_base> + H'0604 + (H'10 × q),
 RSCANnRMPTRqLH: <RSCFDn_base> + H'0605 + (H'10 × q),
 RSCANnRMPTRqHL: <RSCFDn_base> + H'0606 + (H'10 × q),
 RSCANnRMPTRqHH: <RSCFDn_base> + H'0607 + (H'10 × q)
- Initial Value:** H'0000 0000

Bit	31	30	29	28	27	26	25	24	23	22	21	20	19	18	17	16
	RMDLC[3:0]				RMPTR[11:0]											
Initial Value	0	0	0	0	0	0	0	0	0	0	0	0	0	0	0	0
R/W	R	R	R	R	R	R	R	R	R	R	R	R	R	R	R	R
Bit	15	14	13	12	11	10	9	8	7	6	5	4	3	2	1	0
	RMTS[15:0]															
Initial Value	0	0	0	0	0	0	0	0	0	0	0	0	0	0	0	0
R/W	R	R	R	R	R	R	R	R	R	R	R	R	R	R	R	R

Bit	Bit Name	Initial Value	R/W	Description
31 to 28	RMDLC[3:0]	All 0	R	Receive Buffer DLC Data b31 b30 b29 b28 0 0 0 0: No data byte 0 0 0 1: 1 data byte 0 0 1 0: 2 data bytes 0 0 1 1: 3 data bytes 0 1 0 0: 4 data bytes 0 1 0 1: 5 data bytes 0 1 1 0: 6 data bytes 0 1 1 1: 7 data bytes 1 X X X: 8 data bytes
27 to 16	RMPTR[11:0]	All 0	R	Receive Buffer Label Data Label information of the received message.
15 to 0	RMTS[15:0]	All 0	R	Receive Buffer Timestamp Data Timestamp value of the received message.

RMDLC[3:0] Bits

These bits indicate the data length of the message stored in the receive buffer.

RMPTR[11:0] Bits

These bits indicate the label information of the message stored in the receive buffer.

RMTS[15:0] Bits

These bits indicate the timestamp value of the message stored in the receive buffer.

28.3.6.5 RSCANnRMDF0_q — Receive Buffer Data Field 0 Register (q = 0 to 31)

Access Size: RSCANnRMDF0_q register can be read only in 32-bit units
 RSCANnRMDF0_qL, RSCANnRMDF0_qH registers can be read only in 16-bit units
 RSCANnRMDF0_qLL, RSCANnRMDF0_qLH, RSCANnRMDF0_qHL, RSCANnRMDF0_qHH registers can be read only in 8-bit units

Address(es): RSCANnRMDF0_q: <RSCFDn_base> + H'0608 + (H'10 × q)
 RSCANnRMDF0_qL: <RSCFDn_base> + H'0608 + (H'10 × q),
 RSCANnRMDF0_qH: <RSCFDn_base> + H'060A + (H'10 × q)
 RSCANnRMDF0_qLL: <RSCFDn_base> + H'0608 + (H'10 × q),
 RSCANnRMDF0_qLH: <RSCFDn_base> + H'0609 + (H'10 × q),
 RSCANnRMDF0_qHL: <RSCFDn_base> + H'060A + (H'10 × q),
 RSCANnRMDF0_qHH: <RSCFDn_base> + H'060B + (H'10 × q)

Initial Value: H'0000 0000

Bit	31	30	29	28	27	26	25	24	23	22	21	20	19	18	17	16
	RMDB3[7:0]								RMDB2[7:0]							
Initial Value	0	0	0	0	0	0	0	0	0	0	0	0	0	0	0	0
R/W	R	R	R	R	R	R	R	R	R	R	R	R	R	R	R	R
Bit	15	14	13	12	11	10	9	8	7	6	5	4	3	2	1	0
	RMDB1[7:0]								RMDB0[7:0]							
Initial Value	0	0	0	0	0	0	0	0	0	0	0	0	0	0	0	0
R/W	R	R	R	R	R	R	R	R	R	R	R	R	R	R	R	R

Bit	Bit Name	Initial Value	R/W	Description
31 to 24	RMDB3[7:0]	All 0	R	Receive Buffer Data Byte 3
23 to 16	RMDB2[7:0]	All 0	R	Receive Buffer Data Byte 2
15 to 8	RMDB1[7:0]	All 0	R	Receive Buffer Data Byte 1
7 to 0	RMDB0[7:0]	All 0	R	Receive Buffer Data Byte 0
Data for a message stored in the receive buffer can be read.				

When the RMDLC[3:0] value in the RSCANnRMPTRq register is smaller than 1000b, data bytes for which no data is set are read as H'00.

28.3.6.6 RSCANnRMDF1_q — Receive Buffer Data Field 1 Register (q = 0 to 31)

Access Size: RSCANnRMDF1_q register can be read only in 32-bit units
 RSCANnRMDF1_qL, RSCANnRMDF1_qH registers can be read only in 16-bit units
 RSCANnRMDF1_qLL, RSCANnRMDF1_qLH, RSCANnRMDF1_qHL, RSCANnRMDF1_qHH registers can be read only in 8-bit units

Address(es): RSCANnRMDF1_q: <RSCFDn_base> + H'060C + (H'10 × q)
 RSCANnRMDF1_qL: <RSCFDn_base> + H'060C + (H'10 × q),
 RSCANnRMDF1_qH: <RSCFDn_base> + H'060E + (H'10 × q)
 RSCANnRMDF1_qLL: <RSCFDn_base> + H'060C + (H'10 × q),
 RSCANnRMDF1_qLH: <RSCFDn_base> + H'060D + (H'10 × q),
 RSCANnRMDF1_qHL: <RSCFDn_base> + H'060E + (H'10 × q),
 RSCANnRMDF1_qHH: <RSCFDn_base> + H'060F + (H'10 × q)

Initial Value: H'0000 0000

Bit	31	30	29	28	27	26	25	24	23	22	21	20	19	18	17	16
	RMDB7[7:0]								RMDB6[7:0]							
Initial Value	0	0	0	0	0	0	0	0	0	0	0	0	0	0	0	0
R/W	R	R	R	R	R	R	R	R	R	R	R	R	R	R	R	R
Bit	15	14	13	12	11	10	9	8	7	6	5	4	3	2	1	0
	RMDB5[7:0]								RMDB4[7:0]							
Initial Value	0	0	0	0	0	0	0	0	0	0	0	0	0	0	0	0
R/W	R	R	R	R	R	R	R	R	R	R	R	R	R	R	R	R

Bit	Bit Name	Initial Value	R/W	Description
31 to 24	RMDB7[7:0]	All 0	R	Receive Buffer Data Byte 7
23 to 16	RMDB6[7:0]	All 0	R	Receive Buffer Data Byte 6
15 to 8	RMDB5[7:0]	All 0	R	Receive Buffer Data Byte 5
7 to 0	RMDB4[7:0]	All 0	R	Receive Buffer Data Byte 4

Data for a message stored in the receive buffer can be read.

When the RMDLC[3:0] value in the RSCANnRMPTRq register is smaller than 1000b, data bytes for which no data is set are read as H'00.

28.3.7 Details of Receive FIFO Buffer-related Registers

28.3.7.1 RSCANnRFCCx — Receive FIFO Buffer Configuration and Control Register (x = 0 to 7)

Access Size: RSCANnRFCCxregister can be read/written in 32-bit units
 RSCANnRFCCxL, RSCANnRFCCxH registers can be read/written in 16-bit units
 RSCANnRFCCxLL, RSCANnRFCCxLH, RSCANnRFCCxHL, RSCANnRFCCxHH registers can be read/written in 8-bit units

Address(es): RSCANnRFCCx: <RSCFDn_base> + H'00B8 + (H'04 × x)
 RSCANnRFCCxL: <RSCFDn_base> + H'00B8 + (H'04 × x),
 RSCANnRFCCxH: <RSCFDn_base> + H'00BA + (H'04 × x)
 RSCANnRFCCxLL: <RSCFDn_base> + H'00B8 + (H'04 × x),
 RSCANnRFCCxLH: <RSCFDn_base> + H'00B9 + (H'04 × x),
 RSCANnRFCCxHL: <RSCFDn_base> + H'00BA + (H'04 × x),
 RSCANnRFCCxHH: <RSCFDn_base> + 0 H'0BB + (H'04 × x)

Initial Value: H'0000 0000

Bit	31	30	29	28	27	26	25	24	23	22	21	20	19	18	17	16
	—	—	—	—	—	—	—	—	—	—	—	—	—	—	—	—
Initial Value	0	0	0	0	0	0	0	0	0	0	0	0	0	0	0	0
R/W	R	R	R	R	R	R	R	R	R	R	R	R	R	R	R	R
Bit	15	14	13	12	11	10	9	8	7	6	5	4	3	2	1	0
	RFIGCV[2:0]			RFIM	—	RFDC[2:0]			—	—	—	—	—	—	RFIE	RFE
Initial Value	0	0	0	0	0	0	0	0	0	0	0	0	0	0	0	0
R/W	R/W	R/W	R/W	R/W	R	R/W	R/W	R/W	R	R	R	R	R	R	R/W	R/W

Bit	Bit Name	Initial Value	R/W	Description
31 to 16	—	All 0	R	Reserved These bits are read as the value after reset. The write value should be the value after reset.
15 to 13	RFIGCV[2:0]	All 0	R/W	Receive FIFO Interrupt Request Timing Select b15 b14 b13 0 0 0: When FIFO is 1/8 full. 0 0 1: When FIFO is 2/8 full. 0 1 0: When FIFO is 3/8 full. 0 1 1: When FIFO is 4/8 full. 1 0 0: When FIFO is 5/8 full. 1 0 1: When FIFO is 6/8 full. 1 1 0: When FIFO is 7/8 full. 1 1 1: When FIFO is full.
12	RFIM	0	R/W	Receive FIFO Interrupt Source Select 0: An interrupt occurs when the condition set by the RFIGCV[2:0] bits is met. 1: An interrupt occurs each time a message has been received.
11	—	0	R	Reserved These bits are read as the value after reset. The write value should be the value after reset.

Bit	Bit Name	Initial Value	R/W	Description																																				
10 to 8	RFDC[2:0]	All 0	R/W	Receive FIFO Buffer Depth Configuration <table style="margin-left: 20px;"> <tr> <td>b10</td> <td>b9</td> <td>b8</td> <td></td> </tr> <tr> <td>0</td> <td>0</td> <td>0</td> <td>0: 0 messages</td> </tr> <tr> <td>0</td> <td>0</td> <td>1</td> <td>4: 4 messages</td> </tr> <tr> <td>0</td> <td>1</td> <td>0</td> <td>8: 8 messages</td> </tr> <tr> <td>0</td> <td>1</td> <td>1</td> <td>16: 16 messages</td> </tr> <tr> <td>1</td> <td>0</td> <td>0</td> <td>32: 32 messages</td> </tr> <tr> <td>1</td> <td>0</td> <td>1</td> <td>48: 48 messages</td> </tr> <tr> <td>1</td> <td>1</td> <td>0</td> <td>64: 64 messages</td> </tr> <tr> <td>1</td> <td>1</td> <td>1</td> <td>128: 128 messages</td> </tr> </table>	b10	b9	b8		0	0	0	0: 0 messages	0	0	1	4: 4 messages	0	1	0	8: 8 messages	0	1	1	16: 16 messages	1	0	0	32: 32 messages	1	0	1	48: 48 messages	1	1	0	64: 64 messages	1	1	1	128: 128 messages
b10	b9	b8																																						
0	0	0	0: 0 messages																																					
0	0	1	4: 4 messages																																					
0	1	0	8: 8 messages																																					
0	1	1	16: 16 messages																																					
1	0	0	32: 32 messages																																					
1	0	1	48: 48 messages																																					
1	1	0	64: 64 messages																																					
1	1	1	128: 128 messages																																					
7 to 2	—	All 0	R	Reserved These bits are read as the value after reset. The write value should be the value after reset.																																				
1	RFIE	0	R/W	Receive FIFO Interrupt Enable 0: Receive FIFO interrupt is disabled. 1: Receive FIFO interrupt is enabled.																																				
0	RFE	0	R/W	Receive FIFO Buffer Enable 0: No receive FIFO buffer is used. 1: Receive FIFO buffers are used.																																				

RFICV[2:0] Bits

These bits are used to specify the number of received messages for generating a receive FIFO interrupt request when the RFIM bit is set to 0 with a fraction for the total number of buffers (the setting of RFDC[2:0]).

When the RFDC[2:0] bits are set to 001b (4 messages), set the RFICV[2:0] bits to 001b, 011b, 101b, or 111b. Modify these bits only in global reset mode.

RFIM Bit

This bit is used to select a FIFO interrupt source. Modify this bit only in global reset mode.

RFDC[2:0] Bits

These bits are used to select the number of messages that can be stored in a single receive FIFO buffer. When these bits are set to 000b, no receive FIFO buffer should be used. Modify these bits only in global reset mode.

RFIE Bit

Setting the RFIE bit to 1 enables receive FIFO interrupts. Modify this bit when the RFE bit set to 0 (no receive FIFO buffer is used).

RFE Bit

Setting the RFE bit to 1 makes receive FIFO buffers available. Clearing this bit to 0 sets the RFEMP flag in the RSCFDnRFSTSxRSCANnRFSTSx register to 1 (buffer empty). Modify this bit in global operating mode or global test mode.

Set this bit to 1 with another instruction after the settings to all bits in the RSCANnRFCCx register have been done. This bit is cleared to 0 in global reset mode.

28.3.7.2 RSCANnRFSTSx — Receive FIFO Buffer Status Register (x = 0 to 7)

Access Size: RSCANnRFSTSx register can be read/written in 32-bit units
 RSCANnRFSTSxL, RSCANnRFSTSxH registers can be read/written in 16-bit units
 RSCANnRFSTSxLL, RSCANnRFSTSxLH, RSCANnRFSTSxHL, RSCANnRFSTSxHH registers can be read/written in 8-bit units

Address(es): RSCANnRFSTSx: <RSCFDn_base> + H'00D8 + (H'04 × x)
 RSCANnRFSTSxL: <RSCFDn_base> + H'00D8 + (H'04 × x),
 RSCANnRFSTSxH: <RSCFDn_base> + H'00DA + (H'04 × x)
 RSCANnRFSTSxLL: <RSCFDn_base> + H'00D8 + (H'04 × x),
 RSCANnRFSTSxLH: <RSCFDn_base> + H'00D9 + (H'04 × x),
 RSCANnRFSTSxHL: <RSCFDn_base> + H'00DA + (H'04 × x),
 RSCANnRFSTSxHH: <RSCFDn_base> + H'00DB + (H'04 × x)

Initial Value: H'0000 0001

Bit	31	30	29	28	27	26	25	24	23	22	21	20	19	18	17	16
	—	—	—	—	—	—	—	—	—	—	—	—	—	—	—	—
Initial Value	0	0	0	0	0	0	0	0	0	0	0	0	0	0	0	0
R/W	R	R	R	R	R	R	R	R	R	R	R	R	R	R	R	R
Bit	15	14	13	12	11	10	9	8	7	6	5	4	3	2	1	0
	RFMC[7:0]								—	—	—	—	RFIF	RFMLT	RFFLL	RFEMP
Initial Value	0	0	0	0	0	0	0	0	0	0	0	0	0	0	0	0
R/W	R	R	R	R	R	R	R	R	R	R	R	R	R/W*1	R/W*1	R	R

Bit	Bit Name	Initial Value	R/W	Description
31 to 16	—	All 0	R	Reserved These bits are read as the value after reset. The write value should be the value after reset.
15 to 8	RFMC[7:0]	All 0	R	Receive FIFO Unread Message Counter The number of unread messages stored in the receive FIFO buffer is displayed.
7 to 4	—	All 0	R	Reserved These bits are read as the value after reset. The write value should be the value after reset.
3	RFIF	0	R/W*1	Receive FIFO Interrupt Request Flag 0: No receive FIFO interrupt request is present. 1: A receive FIFO interrupt request is present.
2	RFMLT	0	R/W*1	Receive FIFO Message Lost Flag 0: No receive FIFO message is lost. 1: A receive FIFO message is lost.
1	RFFLL	0	R	Receive FIFO Buffer Full Status Flag 0: The receive FIFO buffer is not full. 1: The receive FIFO buffer is full.
0	RFEMP	0	R	Receive FIFO Buffer Empty Status Flag 0: The receive FIFO buffer contains unread message. 1: The receive FIFO buffer contains no unread message (buffer empty).

Note 1. The only effective value for writing to this flag bit is 0, which clears the bit. Otherwise writing to the bit results in retention of its state.

RFMC[7:0] Flag

This flag indicates the number of unread messages in the receive FIFO buffer. This flag becomes H'00 when the RFE bit in the RSCANnRFCCx register is set to 0.

RFIF Flag

This flag is set to 1 when the receive FIFO interrupt request generation conditions set by the RFIGCV[2:0] bits and the RFIM bit in the RSCANnRFCCx register are met. This flag is cleared to 0 in global reset mode or by writing 0 to this flag. Modify this bit in global operating mode or global test mode.

To clear the flags of the register to 0, the program must write 0 to the corresponding flag to be cleared. When writing 0, using store instruction, set the bit to be set to "0" to "0", and the bits not to be set to "0" to "1".

RFMLT Flag

This flag is set to 1 when an attempt is made to store a new message while the receive FIFO buffer is full. In this case, the new message is discarded.

This flag is cleared to 0 in global reset mode or by writing 0 to this flag.

Modify this bit in global operating mode or global test mode.

To clear the flags of the register to 0, the program must write 0 to the corresponding flag to be cleared. When writing 0, using store instruction, set the bit to be set to "0" to "0", and the bits not to be set to "0" to "1".

RFLL Flag

This flag is set to 1 when the number of messages stored in the receive FIFO buffer matches the FIFO buffer depth set by the RFDC[2:0] bits in the RSCANnRFCCx register.

If the number of messages stored in the receive FIFO buffer becomes smaller than the FIFO buffer depth set by the RFDC[2:0] bits, this flag is cleared to 0. This flag is also cleared to 0 when the RFE bit in the RSCANnRFCCx register is set to 0 (no receive FIFO buffer is used) or in global reset mode.

RFEMP Flag

This flag is set to 1 when all messages in the receive FIFO buffer have been read. This flag is also set to 1 when the RFE bit in the RSCANnRFCCx register is 0 or in global reset mode.

This flag is cleared to 0 when even a single received message has been stored in the receive FIFO buffer.

NOTE

To clear the RFMLT or RFIF flag to 0, use a store instruction to write "0" to the given flag and "1" to the other flags.

28.3.7.3 RSCANnRFPCTR_x — Receive FIFO Buffer Pointer Control Register (x = 0 to 7)

Access Size: RSCANnRFPCTR_x register can only be written in 32-bit units
 RSCANnRFPCTR_{xL}, RSCANnRFPCTR_{xH} registers can only be written in 16-bit units
 RSCANnRFPCTR_{xLL}, RSCANnRFPCTR_{xLH}, RSCANnRFPCTR_{xHL}, RSCANnRFPCTR_{xHH} registers can only be written in 8-bit units

Address(es): RSCANnRFPCTR_x: <RSCFDn_base> + H'00F8 + (H'04 × x)
 RSCANnRFPCTR_{xL}: <RSCFDn_base> + H'00F8 + (H'04 × x),
 RSCANnRFPCTR_{xH}: <RSCFDn_base> + H'00FA + (H'04 × x)
 RSCANnRFPCTR_{xLL}: <RSCFDn_base> + H'00F8 + (H'04 × x),
 RSCANnRFPCTR_{xLH}: <RSCFDn_base> + H'00F9 + (H'04 × x),
 RSCANnRFPCTR_{xHL}: <RSCFDn_base> + H'00FA + (H'04 × x),
 RSCANnRFPCTR_{xHH}: <RSCFDn_base> + H'00FB + (H'04 × x)

Initial Value: H'0000 0000

Bit	31	30	29	28	27	26	25	24	23	22	21	20	19	18	17	16
	—	—	—	—	—	—	—	—	—	—	—	—	—	—	—	—
Initial Value	0	0	0	0	0	0	0	0	0	0	0	0	0	0	0	0
R/W	R	R	R	R	R	R	R	R	R	R	R	R	R	R	R	R
Bit	15	14	13	12	11	10	9	8	7	6	5	4	3	2	1	0
	—	—	—	—	—	—	—	—	RFPC[7:0]							
Initial Value	0	0	0	0	0	0	0	0	0	0	0	0	0	0	0	0
R/W	R	R	R	R	R	R	R	R	W	W	W	W	W	W	W	W

Bit	Bit Name	Initial Value	R/W	Description
31 to 8	—	All 0	R	Reserved The write value should be the value after reset.
7 to 0	RFPC[7:0]	All 0	W	Receive FIFO Pointer Control When these bits are set to H'FF, the read pointer moves to the next unread message in the receive FIFO buffer.

RFPC[7:0] Bits

When the RFPC[7:0] bits are set to H'FF, the read pointer moves to the next unread message in the receive FIFO buffer. At this time, the RFMC[7:0] (receive FIFO unread message counter) value in the RSCANnRFSTS_x register is decremented. Read the RSCANnRFID_x, RSCANnRFPTR_x, RSCANnRFDF0_x, and RSCANnRFDF1_x registers to read messages in the receive FIFO buffer, and then write H'FF to the RFPC[7:0] bits.

When writing H'FF to these bits, make sure that the RFE bit in the RSCANnRFCC_x register is set to 1 (receive FIFO buffers are used) and the RFEMP flag in the RSCANnRFSTS_x register is 0 (the receive FIFO buffer contains unread messages).

28.3.7.4 RSCANnRFIDx — Receive FIFO Buffer Access ID Register (x = 0 to 7)

Access Size: RSCANnRFIDx register can be read only in 32-bit units
RSCANnRFIDxL, RSCANnRFIDxH registers can be read only in 16-bit units
RSCANnRFIDxLL, RSCANnRFIDxLH, RSCANnRFIDxHL, RSCANnRFIDxHH registers can be read only in 8-bit units

Address(es): RSCANnRFIDx: <RSCFDn_base> + H'0E00 + (H'10 × x)
RSCANnRFIDxL: <RSCFDn_base> + H'0E00 + (H'10 × x),
RSCANnRFIDxH: <RSCFDn_base> + H'0E02 + (H'10 × x)
RSCANnRFIDxLL: <RSCFDn_base> + H'0E00 + (H'10 × x),
RSCANnRFIDxLH: <RSCFDn_base> + H'0E01 + (H'10 × x),
RSCANnRFIDxHL: <RSCFDn_base> + H'0E02 + (H'10 × x),
RSCANnRFIDxHH: <RSCFDn_base> + H'0E03 + (H'10 × x)

Initial Value: H'0000 0000

Bit	31	30	29	28	27	26	25	24	23	22	21	20	19	18	17	16
	RFIDE	RFRTR	—	RFID[28:16]												
Initial Value	0	0	0	0	0	0	0	0	0	0	0	0	0	0	0	0
R/W	R	R	R	R	R	R	R	R	R	R	R	R	R	R	R	R
Bit	15	14	13	12	11	10	9	8	7	6	5	4	3	2	1	0
	RFID[15:0]															
Initial Value	0	0	0	0	0	0	0	0	0	0	0	0	0	0	0	0
R/W	R	R	R	R	R	R	R	R	R	R	R	R	R	R	R	R

Bit	Bit Name	Initial Value	R/W	Description
31	RFIDE	0	R	Receive FIFO Buffer IDE 0: Standard ID 1: Extended ID
30	RFRTR	0	R	Receive FIFO Buffer RTR 0: Data frame 1: Remote frame
29	—	0	R	Reserved This bit is read as the value after reset.
28 to 0	RFID[28:0]	All 0	R	Receive FIFO Buffer ID Data The standard ID or extended ID of received message can be read. Read bits b10 to b0 for standard ID. Bits b28 to b1 are read as 0.

RFIDE Bit

This bit indicates the ID format (standard ID or extended ID) of the message stored in the receive FIFO buffer.

RFRTR Bit

This bit indicates the frame format (data frame or remote frame) of the message stored in the receive FIFO buffer.

RFID[28:0] Bits

These bits indicate the ID of the message stored in the receive FIFO buffer.

28.3.7.5 RSCANnRFPTRx — Receive FIFO Buffer Access Pointer Register (x = 0 to 7)

- Access Size:** RSCANnRFPTRx register can be read only in 32-bit units
 RSCANnRFPTRxL, RSCANnRFPTRxH registers can be read only in 16-bit units
 RSCANnRFPTRxLL, RSCANnRFPTRxLH, RSCANnRFPTRxHL, RSCANnRFPTRxHH registers can be read only in 8-bit units
- Address(es):** RSCANnRFPTRx: <RSCFDn_base> + H'0E04 + (H'10 × x)
 RSCANnRFPTRxL: <RSCFDn_base> + H'0E04 + (H'10 × x),
 RSCANnRFPTRxH: <RSCFDn_base> + H'0E06 + (H'10 × x)
 RSCANnRFPTRxLL: <RSCFDn_base> + H'0E04 + (H'10 × x),
 RSCANnRFPTRxLH: <RSCFDn_base> + H'0E05 + (H'10 × x),
 RSCANnRFPTRxHL: <RSCFDn_base> + H'0E06 + (H'10 × x),
 RSCANnRFPTRxHH: <RSCFDn_base> + H'0E07 + (H'10 × x)
- Initial Value:** H'0000 0000

Bit	31	30	29	28	27	26	25	24	23	22	21	20	19	18	17	16
	RFDLC[3:0]				RFPTR[11:0]											
Initial Value	0	0	0	0	0	0	0	0	0	0	0	0	0	0	0	0
R/W	R	R	R	R	R	R	R	R	R	R	R	R	R	R	R	R
Bit	15	14	13	12	11	10	9	8	7	6	5	4	3	2	1	0
	RFTS[15:0]															
Initial Value	0	0	0	0	0	0	0	0	0	0	0	0	0	0	0	0
R/W	R	R	R	R	R	R	R	R	R	R	R	R	R	R	R	R

Bit	Bit Name	Initial Value	R/W	Description
31 to 28	RFDLC[3:0]	All 0	R	Receive FIFO Buffer DLC Data b31 b30 b29 b28 0 0 0 0: 0 data bytes 0 0 0 1: 1 data byte 0 0 1 0: 2 data bytes 0 0 1 1: 3 data bytes 0 1 0 0: 4 data bytes 0 1 0 1: 5 data bytes 0 1 1 0: 6 data bytes 0 1 1 1: 7 data bytes 1 X X X: 8 data bytes
27 to 16	RFPTR[11:0]	All 0	R	Receive FIFO Buffer Label Data Label information of the received message can be read.
15 to 0	RFTS[15:0]	All 0	R	Receive FIFO Buffer Timestamp Data Timestamp value of the received message can be read.

RFDLC[3:0] Bits

These bits contain the data length of the message stored in the receive FIFO buffer.

RFPTR[11:0] Bits

These bits contain the label information of the message stored in the receive FIFO buffer.

RFTS[15:0] Bits

These bits contain the timestamp value of the message stored in the receive FIFO buffer.

28.3.7.6 RSCANnRFDF0_x — Receive FIFO Buffer Access Data Field 0 Register (x = 0 to 7)

Access Size: RSCANnRFDF0_x register can be read only in 32-bit units
 RSCANnRFDF0_xL, RSCANnRFDF0_xH registers can be read only in 16-bit units
 RSCANnRFDF0_xLL, RSCANnRFDF0_xLH, RSCANnRFDF0_xHL, RSCANnRFDF0_xHH registers can be read only in 8-bit units

Address(es): RSCANnRFDF0_x: <RSCFDn_base> + H'0E08 + (H'10 × x)
 RSCANnRFDF0_xL: <RSCFDn_base> + H'0E08 + (H'10 × x),
 RSCANnRFDF0_xH: <RSCFDn_base> + H'0E0A + (H'10 × x)
 RSCANnRFDF0_xLL: <RSCFDn_base> + H'0E08 + (H'10 × x),
 RSCANnRFDF0_xLH: <RSCFDn_base> + H'0E09 + (H'10 × x),
 RSCANnRFDF0_xHL: <RSCFDn_base> + H'0E0A + (H'10 × x),
 RSCANnRFDF0_xHH: <RSCFDn_base> + H'0E0B + (H'10 × x)

Initial Value: H'0000 0000

Bit	31	30	29	28	27	26	25	24	23	22	21	20	19	18	17	16
	RFDB3[7:0]								RFDB2[7:0]							
Initial Value	0	0	0	0	0	0	0	0	0	0	0	0	0	0	0	0
R/W	R	R	R	R	R	R	R	R	R	R	R	R	R	R	R	R
Bit	15	14	13	12	11	10	9	8	7	6	5	4	3	2	1	0
	RFDB1[7:0]								RFDB0[7:0]							
Initial Value	0	0	0	0	0	0	0	0	0	0	0	0	0	0	0	0
R/W	R	R	R	R	R	R	R	R	R	R	R	R	R	R	R	R

Bit	Bit Name	Initial Value	R/W	Description
31 to 24	RFDB3[7:0]	All 0	R	Receive FIFO Buffer Data Byte 3
23 to 16	RFDB2[7:0]	All 0	R	Receive FIFO Buffer Data Byte 2
15 to 8	RFDB1[7:0]	All 0	R	Receive FIFO Buffer Data Byte 1
7 to 0	RFDB0[7:0]	All 0	R	Receive FIFO Buffer Data Byte 0

Data for a message stored in the receive FIFO buffer can be read.

When the RFDLC[3:0] value in the RSCANnRFPTRx register is smaller than 1000b, data bytes for which no data is set are read as H'00.

28.3.7.7 RSCANnRFDF1_x — Receive FIFO Buffer Access Data Field 1 Register (x = 0 to 7)

Access Size: RSCANnRFDF1_x register can be read only in 32-bit units
 RSCANnRFDF1_xL, RSCANnRFDF1_xH registers can be read only in 16-bit units
 RSCANnRFDF1_xLL, RSCANnRFDF1_xLH, RSCANnRFDF1_xHL, RSCANnRFDF1_xHH registers can be read only in 8-bit units

Address(es): RSCANnRFDF1_x: <RSCFDn_base> + H'0E0C + (H'10 × x)
 RSCANnRFDF1_xL: <RSCFDn_base> + H'0E0C + (H'10 × x),
 RSCANnRFDF1_xH: <RSCFDn_base> + H'0E0E + (H'10 × x)
 RSCANnRFDF1_xLL: <RSCFDn_base> + H'0E0C + (H'10 × x),
 RSCANnRFDF1_xLH: <RSCFDn_base> + H'0E0D + (H'10 × x),
 RSCANnRFDF1_xHL: <RSCFDn_base> + H'0E0E + (H'10 × x),
 RSCANnRFDF1_xHH: <RSCFDn_base> + H'0E0F + (H'10 × x)

Initial Value: H'0000 0000

Bit	31	30	29	28	27	26	25	24	23	22	21	20	19	18	17	16
	RFDB7[7:0]								RFDB6[7:0]							
Initial Value	0	0	0	0	0	0	0	0	0	0	0	0	0	0	0	0
R/W	R	R	R	R	R	R	R	R	R	R	R	R	R	R	R	R
Bit	15	14	13	12	11	10	9	8	7	6	5	4	3	2	1	0
	RFDB5[7:0]								RFDB4[7:0]							
Initial Value	0	0	0	0	0	0	0	0	0	0	0	0	0	0	0	0
R/W	R	R	R	R	R	R	R	R	R	R	R	R	R	R	R	R

Bit	Bit Name	Initial Value	R/W	Description
31 to 24	RFDB7[7:0]	All 0	R	Receive FIFO Buffer Data Byte 7
23 to 16	RFDB6[7:0]	All 0	R	Receive FIFO Buffer Data Byte 6
15 to 8	RFDB5[7:0]	All 0	R	Receive FIFO Buffer Data Byte 5
7 to 0	RFDB4[7:0]	All 0	R	Receive FIFO Buffer Data Byte 4

Data for a message stored in the receive FIFO buffer can be read.

When the RFDLC[3:0] value in the RSCANnRFPTRx register is smaller than 1000b, data bytes for which no data is set are read as H'00.

28.3.8 Details of Transmit/Receive FIFO Buffer-related Registers

28.3.8.1 RSCANnCFCK — Transmit/receive FIFO Buffer Configuration and Control Register k (k = 0 to 5)

Access Size: RSCANnCFCK register can be read/written in 32-bit units
 RSCANnCFCKL, RSCANnCFCKH registers can be read/written in 16-bit units
 RSCANnCFCKLL, RSCANnCFCKLH, RSCANnCFCKHL, RSCANnCFCKHH registers can be read/written in 8-bit units

Address(es): RSCANnCFCK: <RSCFDn_base> + H'0118 + (H'04 × k)
 RSCANnCFCKL: <RSCFDn_base> + H'0118 + (H'04 × k),
 RSCANnCFCKH: <RSCFDn_base> + H'011A + (H'04 × k)
 RSCANnCFCKLL: <RSCFDn_base> + H'0118 + (H'04 × k),
 RSCANnCFCKLH: <RSCFDn_base> + H'0119 + (H'04 × k),
 RSCANnCFCKHL: <RSCFDn_base> + H'011A + (H'04 × k),
 RSCANnCFCKHH: <RSCFDn_base> + H'011B + (H'04 × k)

Initial Value: H'0000 0000

Bit	31	30	29	28	27	26	25	24	23	22	21	20	19	18	17	16
	CFITT[7:0]							CFTML[3:0]			CFITR	CFITSS	CFM[1:0]			
Initial Value	0	0	0	0	0	0	0	0	0	0	0	0	0	0	0	0
R/W	R/W	R/W	R/W	R/W	R/W	R/W	R/W	R/W	R/W	R/W	R/W	R/W	R/W	R/W	R/W	R/W
Bit	15	14	13	12	11	10	9	8	7	6	5	4	3	2	1	0
	CFGCV[2:0]		CFIM	—	CFDC[2:0]		—	—	—	—	—	—	CFIXIE	CFRXIE	CFE	
Initial Value	0	0	0	0	0	0	0	0	0	0	0	0	0	0	0	0
R/W	R/W	R/W	R/W	R/W	R	R/W	R/W	R/W	R	R	R	R	R	R/W	R/W	R/W

Bit	Bit Name	Initial Value	R/W	Description
31 to 24	CFITT[7:0]	All 0	R	Set a message transmission interval. Set Value: H'00 to H'FF
23 to 20	CFTML[3:0]	All 0	R	Transmit Buffer Link Configuration Set the transmit buffer number to be linked to the transmit/receive FIFO buffer.
19	CFITR	0	R/W	Transmit/Receive FIFO Interval Timer Resolution 0: Clock dividing pclk by (ITRCP[15:0] bits) 1: Clock dividing pclk by (ITRCP[15:0] bits × 10)
18	CFITSS	0	R/W	Transmit/Receive FIFO Interval Timer Clock Source Select 0: Interval timer clock source selected by the CFITR bit 1: Interval timer clock source is the bit time clock for the channel to which the FIFO is linked.
17 to 16	CFM[1:0]	All 0	R/W	Transmit/Receive FIFO Mode Select b17 b16 0 0: Receive mode 0 1: Transmit mode 1 0: Gateway mode 1 1: Setting prohibited

Bit	Bit Name	Initial Value	R/W	Description
15 to 13	CFIGCV[2:0]	All 0	R/W	Transmit/Receive FIFO Receive Interrupt Request Timing Select b15 b14 b13 0 0 0: When FIFO is 1/8 full. 0 0 1: When FIFO is 2/8 full. 0 1 0: When FIFO is 3/8 full. 0 1 1: When FIFO is 4/8 full. 1 0 0: When FIFO is 5/8 full. 1 0 1: When FIFO is 6/8 full. 1 1 0: When FIFO is 7/8 full. 1 1 1: When FIFO is full.
12	CFIM	0	R/W	Transmit/Receive FIFO Interrupt Source Select 0: <ul style="list-style-type: none"> Receive mode/gateway mode When the number of received messages has met the condition set by the CFIGCV[2:0] bits, a FIFO receive interrupt request is generated. Transmit mode/gateway mode When the buffer becomes empty upon completion of message transmission, a FIFO transmit interrupt request is generated. 1: <ul style="list-style-type: none"> Receive mode/gateway mode A FIFO receive interrupt request is generated each time a message has been received. Transmit mode/gateway mode A FIFO transmit interrupt request is generated each time a message has been transmitted.
11	—	0	R	Reserved This bit is read as the value after reset. The write value should be the value after reset.
10 to 8	CFDC[2:0]	All 0	R/W	Transmit/Receive FIFO Buffer Depth Configuration b10 b9 b8 0 0 0: 0 messages 0 0 1: 4 messages 0 1 0: 8 messages 0 1 1: 16 messages 1 0 0: 32 messages 1 0 1: 48 messages 1 1 0: 64 messages 1 1 1: 128 messages
7 to 3	—	All 0	R	Reserved These bits are read as the value after reset. The write value should be the value after reset.
2	CFTXIE	0	R/W	Transmit/Receive FIFO Transmit Interrupt Enable 0: Transmit/receive FIFO transmit interrupt is disabled. 1: Transmit/receive FIFO transmit interrupt is enabled.
1	CFRXIE	0	R/W	Transmit/Receive FIFO Receive Interrupt Enable 0: Transmit/receive FIFO receive interrupt is disabled. 1: Transmit/receive FIFO receive interrupt is enabled.
0	CFE	0	R/W	Transmit/Receive FIFO Buffer Enable 0: No transmit/receive FIFO buffer is used. 1: Transmit/receive FIFO buffers are used.

CFITT[7:0] Bits

These bits are used to set a message transmission interval when transmitting messages continuously from a transmit/receive FIFO buffer whose CFM[1:0] bits are set to 01b (transmit mode) or 10b (gateway mode).

Clear the CFE bit to 0 (no transmit/receive FIFO buffer is used) before modifying the CFITT[7:0] bits.

CFTML[3:0] Bits

These bits are used to set the number of transmit buffer on the channel which will be linked to transmit/receive FIFO buffer k when the CFM[1:0] bits are set to 01b (transmit mode) or 10b (gateway mode). There are three transmit/receive FIFO buffers per channel, so channel number m of FIFO buffer k is calculated as $m = k/3$ (integer division). The actual assigned transmit buffer number p linked to FIFO buffer k will be $((16 \times m) + CFTML[3:0])$.

See **Table 28.11** and **Table 28.12**, as for the relationship between transmit/receive FIFO buffer k and transmit buffer p. Setting the CFDC[2:0] bits to 001b or more enables the setting of the CFTML[3:0] bits.

Do not link to any transmit buffer which is already allocated to a transmit queue on the identical channel or to another transmit/receive FIFO buffer. Modify these bits only in global reset mode.

CFITR Bit

This bit is enabled when the CFITSS bit is 0.

When this bit is 0, the interval timer clock source is the pclk/2 clock divided by the value of the ITRCP[15:0] bits in the RSCANnGCFG register.

When this bit is 1, the interval timer clock source is the pclk/2 clock divided by (the value of the ITRCP[15:0] bits in the RSCANnGCFG register $\times 10$).

Modify this bit while the CFE bit is set to 0 (no transmit/receive FIFO buffer is used).

CFITSS Bit

When this bit is 0, the clock selected by the CFITR bit is the count source of the interval timer.

When this bit is 1, the bit time clock of the channel to which the FIFO is linked is the count source of the interval timer. Modify this bit while the CFE bit is set to 0 (no transmit/receive FIFO buffer is used).

CFM[1:0] Bits

These bits are used to select transmit/receive FIFO mode. Modify these bits only in global reset mode.

CFIGCV[2:0] Bits

These bits are used to specify the number of received messages for generating a transmit/receive FIFO receive interrupt request when the CFM[1:0] bits are set to 00b (receive mode) or 10b (gateway mode) and the CFIM bit is set to 0 with a fraction for the total number of buffers (the setting of CFDC[2:0]).

When the CFDC[2:0] bits are set to 001b (4 messages), set the CFIGCV[2:0] bits to 001b, 011b, 101b, or 111b. Modify these bits only in global reset mode.

CFIM Bit

This bit is used to select a transmit/receive FIFO interrupt source. Modify this bit only in global reset mode.

CFDC[2:0] Bits

These bits are used to set the number of messages that can be stored in a single transmit/receive FIFO buffer. When these bits are set to 000b, do not use a transmit/receive FIFO buffer. Modify these bits only in global reset mode.

CFTXIE Bit

When this bit is set to 1 and the CFTXIF flag in the RSCANnCFSTSk register is set to 1, a transmit/receive FIFO transmit interrupt request is generated.

Modify this bit with the CFE bit set to 0 (no transmit/receive FIFO buffer is used).

CFRXIE Bit

When this bit is set to 1 and the CFRXIF flag in the RSCANnCFSTSk register is set to 1, a transmit/receive FIFO receive interrupt request is generated.

Modify this bit with the CFE bit set to 0.

CFE Bit

Setting this bit to 1 makes transmit/receive FIFO buffers available.

When this bit is set to 0 in transmit mode or gateway mode, if a message in the transmit/receive FIFO buffer is being transmitted or will be transmitted next, the transmit/receive FIFO buffer becomes empty after completion of transmission of that message, or upon detection of a CAN bus error, or arbitration-lost. In other cases or in receive mode, the transmit/ receive FIFO buffer becomes empty immediately.

This bit is cleared to 0 when the following conditions are met.

- Receive mode: Global reset mode
- Transmit mode or gateway mode: Channel reset mode

Modify this bit in the following mode.

- Receive mode: Global operating mode or global test mode
- Transmit mode or gateway mode: Channel communication mode or channel halt mode

After all other bits in the RSCANnCFCCk register have been set, set this bit to 1 by using another instruction.

28.3.8.2 RSCANnCFSTSk — Transmit/receive FIFO Buffer Status Register (k = 0 to 5)

Access Size: RSCANnCFSTSk register can be read/written in 32-bit units
 RSCANnCFSTSkL, RSCANnCFSTSkH registers can be read/written in 16-bit units
 RSCANnCFSTSkLL, RSCANnCFSTSkLH, RSCANnCFSTSkHL, RSCANnCFSTSkHH registers can be read/written in 8-bit units

Address(es): RSCANnCFSTSk: <RSCFDn_base> + H'0178 + (H'04 × k)
 RSCANnCFSTSkL: <RSCFDn_base> + H'0178 + (H'04 × k),
 RSCANnCFSTSkH: <RSCFDn_base> + H'017A + (H'04 × k)
 RSCANnCFSTSkLL: <RSCFDn_base> + H'0178 + (H'04 × k),
 RSCANnCFSTSkLH: <RSCFDn_base> + H'0179 + (H'04 × k),
 RSCANnCFSTSkHL: <RSCFDn_base> + H'017A + (H'04 × k),
 RSCANnCFSTSkHH: <RSCFDn_base> + H'017B + (H'04 × k)

Initial Value: H'0000 0001

Bit	31	30	29	28	27	26	25	24	23	22	21	20	19	18	17	16
	—	—	—	—	—	—	—	—	—	—	—	—	—	—	—	—
Initial Value	0	0	0	0	0	0	0	0	0	0	0	0	0	0	0	0
R/W	R	R	R	R	R	R	R	R	R	R	R	R	R	R	R	R
Bit	15	14	13	12	11	10	9	8	7	6	5	4	3	2	1	0
	CFMC[7:0]							—	—	—	CFTXIF	CFRXIF	CFMLT	CFLL	CFEMP	
Initial Value	0	0	0	0	0	0	0	0	0	0	0	0	0	0	0	1
R/W	R	R	R	R	R	R	R	R	R	R	R	R/W*1	R/W*1	R/W*1	R	R

Bit	Bit Name	Initial Value	R/W	Description
31 to 16	—	All 0	R	Reserved These bits are read as the value after reset. The write value should be the value after reset.
15 to 8	CFMC[7:0]	All 0	R	Transmit/Receive FIFO Message Counter The number of messages stored in the transmit/receive FIFO buffer.
7 to 5	—	All 0	R	Reserved These bits are read as the value after reset. The write value should be the value after reset.
4	CFTXIF	0	R/W*1	Transmit/Receive FIFO Transmit Interrupt Request Flag 0: No transmit/receive FIFO transmit interrupt request is present. 1: A transmit/receive FIFO transmit interrupt request is present.
3	CFRXIF	0	R/W*1	Transmit/Receive FIFO Receive Interrupt Request Flag 0: No transmit/receive FIFO receive interrupt request is present. 1: A transmit/receive FIFO receive interrupt request is present.
2	CFMLT	0	R/W*1	Transmit/Receive FIFO Message Lost Flag 0: No transmit/receive FIFO message is lost. 1: A transmit/receive FIFO message is lost.
1	CFLL	0	R	Transmit/Receive FIFO Buffer Full Status Flag 0: The transmit/receive FIFO buffer is not full. 1: The transmit/receive FIFO buffer is full.
0	CFEMP	1	R	Transmit/Receive FIFO Buffer Empty Status Flag 0: The transmit/receive FIFO buffer contains messages. 1: The transmit/receive FIFO buffer contains no message (buffer empty).

Note 1. The only effective value for writing to this flag bit is 0, which clears the bit. Otherwise writing to the bit results in retention of its state.

CFMC[7:0] Bits

The CFMC[7:0] bits indicate the following values that depend on the setting of the CFM[1:0] bits in the RSCANnCFCCk register.

- When CFM[1:0] value is 01b (transmit mode): Number of untransmitted messages in the buffer
- When CFM[1:0] value is 00b (receive mode): Number of unread received messages in the buffer
- When CFM[1:0] value is 10b (gateway mode): Number of untransmitted received messages in the buffer

These bits are cleared to 0 when any of the following conditions is met.

- When CFM[1:0] value is 00b: In global reset mode
- When CFM[1:0] value is 01b or 10b: In channel reset mode
- When the CFE bit in the RSCANnCFCCk register is cleared to 0.

CFTXIF Flag

The CFTXIF flag is set to 1 when any of the following conditions is met.

- When the CFM[1:0] bits are set to 01b or 10b, and the factor selected by the CFIM bit in the RSCANnCFCCk register occurs

The CFTXIF flag is cleared to 0 when any of the following conditions is met.

- When 0 is written to the CFTXIF flag
- When the CFM[1:0] bits are set to 00b: In global reset mode
- When the CFM[1:0] bits are set to 01b or 10b: In channel reset mode

Write 0 to this flag in global operating mode or global test mode.

To clear the flags of the register to 0, the program must write 0 to the corresponding flag to be cleared. When writing 0, using store instruction, set the bit to be set to “0” to “0”, and the bits not to be set to “0” to “1”.

CFRXIF Flag

The CFRXIF flag is set to 1 when any of the following conditions is met.

- When the CFM[1:0] bits are set to 00b or 10b, and the factor selected by the CFIM bit in the RSCANnCFCCk register occurs

The CFRXIF flag is cleared to 0 when any of the following conditions is met.

- When 0 is written to the CFRXIF flag
- When the CFM[1:0] bits are set to 00b: In global reset mode
- When the CFM[1:0] bits are set to 01b or 10b: In channel reset mode

Write 0 to this flag in global operating mode or global test mode.

To clear the flags of the register to 0, the program must write 0 to the corresponding flag to be cleared. When writing 0, using store instruction, set the bit to be set to “0” to “0”, and the bits not to be set to “0” to “1”.

CFMLT Flag

The CFMLT flag is set to 1 when any of the following conditions is met.

- When an attempt is made to store a new message while the transmit/receive FIFO buffer is full. In this case, the new message is discarded.

The CFMLT flag is cleared to 0 when any of the following conditions is met.

- When 0 is written to the CFMLT flag
- When the CFM[1:0] bits are set to 00b: In global reset mode
- When the CFM[1:0] bits are set to 01b or 10b: In channel reset mode

Write 0 to this flag in global operating mode or global test mode

To clear the flags of the register to 0, the program must write 0 to the corresponding flag to be cleared. When writing 0, using store instruction, set the bit to be set to “0” to “0”, and the bits not to be set to “0” to “1”.

CFLL Flag

The CFLL flag is set to 1 when any of the following conditions is met.

- When the number of messages stored in the transmit/receive FIFO buffer matches the FIFO buffer depth set by the CFDC[2:0] bits in the RSCANnCFCCk register.

The CFMLT flag is cleared to 0 when any of the following conditions is met.

- When the number of messages stored in the transmit/receive FIFO buffer becomes smaller than the FIFO buffer depth set by the CFDC[2:0] bits.
- When the CFE bit in the RSCANnCFCCk register is 0 (no transmit/receive FIFO buffer is used): When not in the transmit abort
- When the CFM[1:0] bits are set to 00b: In global reset mode
- When the CFM[1:0] bits are set to 01b or 10b: In channel reset mode

CFEMP Flag

The CFEMP flag is set to 1 when any of the following conditions is met.

- When the CFM[1:0] bits are set to 00b: All messages have been read, or in global reset mode
- When the CFM[1:0] bits are set to 01b or 10b: All messages have been transmitted, or in channel reset mode
- When the CFE bit is 0 (no transmit/receive FIFO buffer is used): Not in the transmit abort

The CFEMP flag is cleared to 0 when any of the following conditions is met.

- When the CFM[1:0] bits are set to 00b or 10b: At least one received message has been stored in the transmit/receive FIFO buffer.
- When the CFM[1:0] bits are set to 01b: A value of H'FF has been written to the RSCANnCFPCTRk register after data was written to the RSCANnCFIDk, RSCANnCFPTRk, RSCANnCFDF0_k, and RSCANnCFDF1_k registers.

NOTE

To clear CFTXIF, CFRXIF, or CFMLT flag to 0, the program must write 0. When writing, use a store instruction to write “0” to the given flag and “1” to other flags.

28.3.8.3 RSCANnCFPCTRk — Transmit/receive FIFO Buffer Pointer Control Register (k = 0 to 5)

Access Size: RSCANnCFPCTRk register can only be written in 32-bit units
 RSCANnCFPCTRkL, RSCANnCFPCTRkH registers can only be written in 16-bit units
 RSCANnCFPCTRkLL, RSCANnCFPCTRkLH, RSCANnCFPCTRkHL, RSCANnCFPCTRkHH registers can only be written in 8-bit units

Address(es): RSCANnCFPCTRk: <RSCFDn_base> + H'01D8 + (H'04 × k)
 RSCANnCFPCTRkL: <RSCFDn_base> + H'01D8 + (H'04 × k),
 RSCANnCFPCTRkH: <RSCFDn_base> + H'01DA + (H'04 × k)
 RSCANnCFPCTRkLL: <RSCFDn_base> + H'01D8 + (H'04 × k),
 RSCANnCFPCTRkLH: <RSCFDn_base> + H'01D9 + (H'04 × k),
 RSCANnCFPCTRkHL: <RSCFDn_base> + H'01DA + (H'04 × k),
 RSCANnCFPCTRkHH: <RSCFDn_base> + H'01DB + (H'04 × k)

Initial Value: H'0000 0000

Bit	31	30	29	28	27	26	25	24	23	22	21	20	19	18	17	16
	—	—	—	—	—	—	—	—	—	—	—	—	—	—	—	—
Initial Value	0	0	0	0	0	0	0	0	0	0	0	0	0	0	0	0
R/W	R	R	R	R	R	R	R	R	R	R	R	R	R	R	R	R
Bit	15	14	13	12	11	10	9	8	7	6	5	4	3	2	1	0
	—	—	—	—	—	—	—	—	CFPC[7:0]							
Initial Value	0	0	0	0	0	0	0	0	0	0	0	0	0	0	0	0
R/W	R	R	R	R	R	R	R	R	W	W	W	W	W	W	W	W

Bit	Bit Name	Initial Value	R/W	Description
31 to 8	—	All 0	R	Reserved The write value should be the value after reset.
7 to 0	CFPC[7:0]	All 0	W	Transmit/Receive FIFO Pointer Control <ul style="list-style-type: none"> • Receive mode: Writing H'FF to these bits moves the read pointer to the next unread message in the transmit/receive FIFO buffer. • Transmit mode: Writing H'FF to these bits moves the write pointer to the next stage of the transmit/receive FIFO buffer. • Gateway mode: Setting prohibited

CFPC[7:0] Bits

- Receive mode (CFM[1:0] value in the RSCANnCFCCk register is 00b):
Writing H'FF to the CFPC[7:0] bits moves the read pointer to the next unread message in the transmit/receive FIFO buffer. At this time, the CFMC[7:0] value (transmit/receive FIFO message counter) in the RSCANnCFSTSk register is decremented. Read the RSCANnCFIDk, RSCANnCFPTRk, RSCANnCFDF0_k, and RSCANnCFDF1_k registers to read messages from the transmit/receive FIFO buffer, and then write H'FF to the CFPC[7:0] bits.
When writing H'FF to these bits, make sure that the CFE bit in the RSCANnCFCCk register is set to 1 (transmit/receive FIFO buffers are used) and the CFEMP flag in the RSCANnCFSTSk register is 0 (the transmit/receive FIFO buffer contains messages).
- Transmit mode (CFM[1:0] value in the RSCANnCFCCk register is 01b):
Writing H'FF to the CFPC[7:0] bits stores the data written to the RSCANnCFIDk, RSCANnCFPTRk, RSCANnCFDF0_k, and RSCANnCFDF1_k registers in the transmit/receive FIFO buffer and moves the write pointer to the next stage of the transmit/receive FIFO buffer. At this time, the CFMC[7:0] value is incremented. Write transmit messages to the RSCANnCFIDk, RSCANnCFPTRk, RSCANnCFDF0_k, and RSCANnCFDF1_k registers before writing H'FF to the CFPC[7:0] bits.
When writing H'FF to these bits, make sure that the CFE bit in the RSCANnCFCCk register is set to 1 and the CFFLL flag in the RSCANnCFSTSk register is 0 (the transmit/receive FIFO buffer is not full).
- Gateway mode (CFM[1:0] value in the RSCANnCFCCk register is 10b):
Setting prohibited

28.3.8.4 RSCANnCFIDk — Transmit/receive FIFO Buffer Access ID Register (k = 0 to 5)

Access Size: RSCANnCFIDk register can be read/written in 32-bit units
 RSCANnCFIDkL, RSCANnCFIDkH registers can be read/written in 16-bit units
 RSCANnCFIDkLL, RSCANnCFIDkLH, RSCANnCFIDkHL, RSCANnCFIDkHH registers can be read/written in 8-bit units

Address(es): RSCANnCFIDk: <RSCFDn_base> + H'0E80 + (H'10 × k)
 RSCANnCFIDkL: <RSCFDn_base> + H'0E80 + (H'10 × k),
 RSCANnCFIDkH: <RSCFDn_base> + H'0E82 + (H'10 × k)
 RSCANnCFIDkLL: <RSCFDn_base> + H'0E80 + (H'10 × k),
 RSCANnCFIDkLH: <RSCFDn_base> + H'0E81 + (H'10 × k),
 RSCANnCFIDkHL: <RSCFDn_base> + H'0E82 + (H'10 × k),
 RSCANnCFIDkHH: <RSCFDn_base> + H'0E83 + (H'10 × k)

Initial Value: H'0000 0000

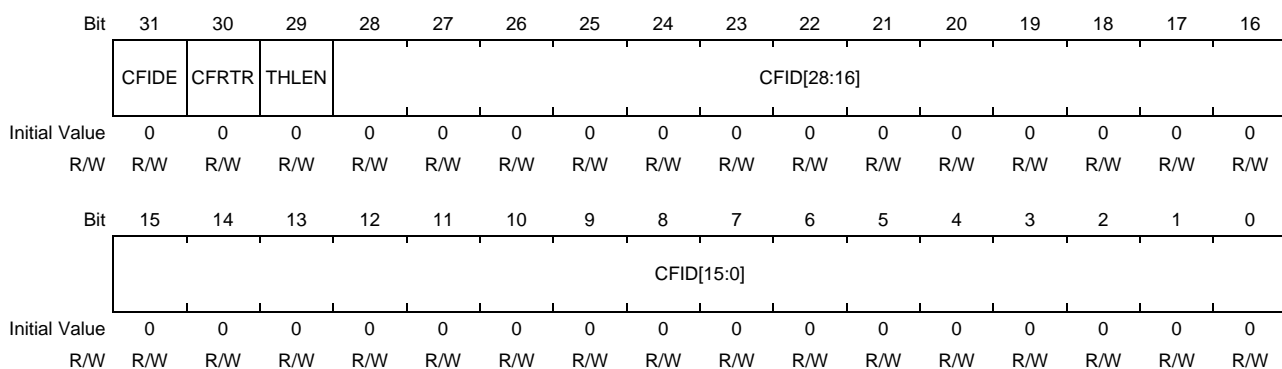

Bit	Bit Name	Initial Value	R/W	Description
31	CFIDE	0	R/W	Transmit/Receive FIFO Buffer IDE 0: Standard ID 1: Extended ID
30	CFRTR	0	R/W	Transmit/Receive FIFO Buffer RTR 0: Data frame 1: Remote frame
29	THLEN	0	R/W	Transmit History Data Store Enable This bit is valid only when the CFM[1:0] value is 01b (transmit mode). 0: Transmit history data is not stored in the buffer. 1: Transmit history data is stored in the buffer.
28 to 0	CFID[28:0]	All 0	R/W	Transmit/Receive FIFO Buffer ID Data <ul style="list-style-type: none"> When CFM[1:0] value is 01b (transmit mode): Set standard ID or extended ID. For standard ID, write an ID to bits 10 to 0 and write 0 to bits 28 to 11. When CFM[1:0] value is 00b (receive mode): Standard ID or extended ID in the received message can be read. For standard ID, read bits 10 to 0. Bits 28 to 11 are read as 0.

This register is writable only when the CFM[1:0] value in the RSCANnCFCCk register is 01b (transmit mode). This register is readable only when the CFM[1:0] value is 00b (receive mode). This RSCFDnCFIDk register should not be read or written when the CFM[1:0] value is 10b (gateway mode).

CFIDE Bit

This bit indicates the ID format (standard ID or extended ID) of the received message stored in the transmit/receive FIFO buffer when the CFM[1:0] value is 00b. When the CFM[1:0] value is 01b, these bits are used to set the ID format of the message to be transmitted from the transmit/receive FIFO buffer.

CFRTR Bit

This bit indicates the data format (data frame or remote frame) of the received message stored in the transmit/receive FIFO buffer when the CFM[1:0] value is 00b. When the CFM[1:0] value is 01b, this bit is used to set the data format of the message to be transmitted from the transmit/receive FIFO buffer.

THLEN Bit

When this bit is set to 1, the transmit history data (label information, buffer number, and buffer type) of transmit messages is stored in the transmit history buffer after transmission is completed.

This bit is enabled when the CFM[1:0] value is 01b (transmit mode).

CFID[28:0] Bits

These bits contain the ID of the received message stored in the transmit/receive FIFO buffer when the CFM[1:0] value is 00b.

When the CFM[1:0] value is 01b, this bit is used to set the ID of the message to be transmitted from the transmit/receive FIFO buffer.

28.3.8.5 RSCANnCFPTRk — Transmit/receive FIFO Buffer Access Pointer Register (k = 0 to 5)

Access Size: RSCANnCFPTRk register can be read/written in 32-bit units
 RSCANnCFPTRkL, RSCANnCFPTRkH registers can be read/written in 16-bit units
 RSCANnCFPTRkLL, RSCANnCFPTRkLH, RSCANnCFPTRkHL, RSCANnCFPTRkHH registers can be read/written in 8-bit units

Address(es): RSCANnCFPTRk: <RSCFDn_base> + H'0E84 + (H'10 × k)
 RSCANnCFPTRkL: <RSCFDn_base> + H'0E84 + (H'10 × k),
 RSCANnCFPTRkH: <RSCFDn_base> + H'0E86 + (H'10 × k)
 RSCANnCFPTRkLL: <RSCFDn_base> + H'0E84 + (H'10 × k),
 RSCANnCFPTRkLH: <RSCFDn_base> + H'0E85 + (H'10 × k),
 RSCANnCFPTRkHL: <RSCFDn_base> + H'0E86 + (H'10 × k),
 RSCANnCFPTRkHH: <RSCFDn_base> + H'0E87 + (H'10 × k)

Initial Value: H'0000 0000

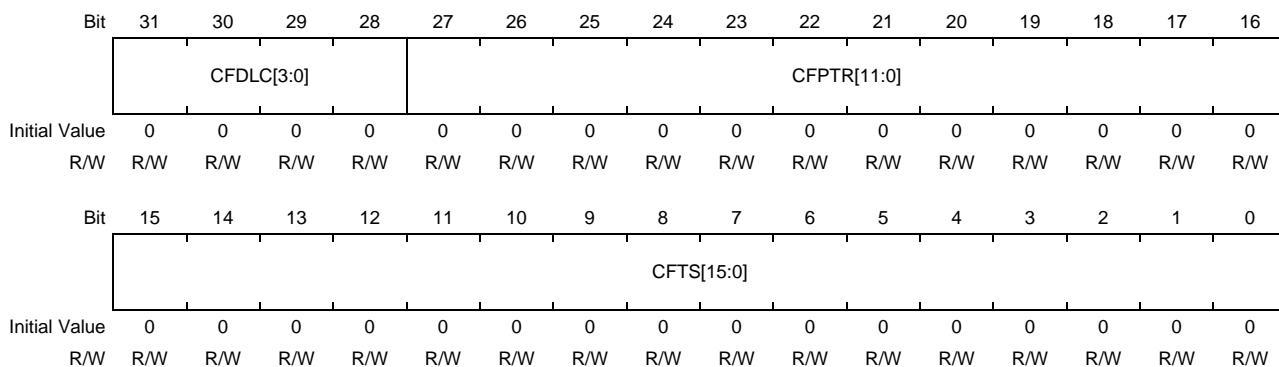

Bit	Bit Name	Initial Value	R/W	Description
31 to 28	CFDLc[3:0]	All 0	R/W	Transmit/Receive FIFO Buffer DLC Data b31 b30 b29 b28 0 0 0 0: 0 data bytes 0 0 0 1: 1 data byte 0 0 1 0: 2 data bytes 0 0 1 1: 3 data bytes 0 1 0 0: 4 data bytes 0 1 0 1: 5 data bytes 0 1 1 0: 6 data bytes 0 1 1 1: 7 data bytes 1 X X X: 8 data bytes
27 to 16	CFPTR[11:0]	All 0	R/W	Transmit/Receive FIFO Buffer Label Data • When CFM[1:0] value is 01b (transmit mode): Set the label information to be stored in the transmit history buffer. Only bits CFPTR[7:0] are valid. • When CFM[1:0] value is 00b (receive mode): The label information of the received message can be read.
15 to 0	CFTS[15:0]	All 0	R/W	Transmit/Receive FIFO Buffer Timestamp Data These bits are valid only when the CFM[1:0] value is 00b (receive mode). The timestamp value of the received message can be read.

This register is writable only when the CFM[1:0] value in the RSCANnCFCCk register is 01b (transmit mode). This register is readable only when the CFM[1:0] value is 00b (receive mode). This register should not be read or written when the CFM[1:0] value is 10b (gateway mode).

CFDLC[3:0] Bits

These bits indicate the data length of the received message stored in the transmit/receive FIFO buffer when the CFM[1:0] value is 00b. When the CFM[1:0] value is 01b, these bits are used to set the data length of the message to be transmitted from the transmit/receive FIFO buffer. If the data length is set to 1001b or more, the actual transmit data defaults to 8 bytes.

CFPTR[11:0] Bits

These bits indicate the label information attached to the received message stored in the transmit/receive FIFO buffer when the CFM[1:0] value is 00b. When the CFM[1:0] value is 01b, the CFPTR[7:0] value is stored in the transmit history buffer when message transmission has been completed.

CFTS[15:0] Bits

These bits indicate the timestamp value of the message stored in the transmit/receive FIFO buffer. These bits are valid when the CFM[1:0] value is 00b.

28.3.8.6 RSCANnCFDF0_k — Transmit/receive FIFO Buffer Access Data Field 0 Register (k = 0 to 5)

Access Size: RSCANnCFDF0_k register can be read/written in 32-bit units
 RSCANnCFDF0_kL, RSCANnCFDF0_kH registers can be read/written in 16-bit units
 RSCANnCFDF0_kLL, RSCANnCFDF0_kLH, RSCANnCFDF0_kHL, RSCANnCFDF0_kHH registers can be read/written in 8-bit units

Address(es): RSCANnCFDF0_k: <RSCFDn_base> + H'0E88 + (H'10 × k)
 RSCANnCFDF0_kL: <RSCFDn_base> + H'0E88 + (H'10 × k),
 RSCANnCFDF0_kH: <RSCFDn_base> + H'0E8A + (H'10 × k)
 RSCANnCFDF0_kLL: <RSCFDn_base> + H'0E88 + (H'10 × k),
 RSCANnCFDF0_kLH: <RSCFDn_base> + H'0E89 + (H'10 × k),
 RSCANnCFDF0_kHL: <RSCFDn_base> + H'0E8A + (H'10 × k),
 RSCANnCFDF0_kHH: <RSCFDn_base> + H'0E8B + (H'10 × k)

Initial Value: H'0000 0000

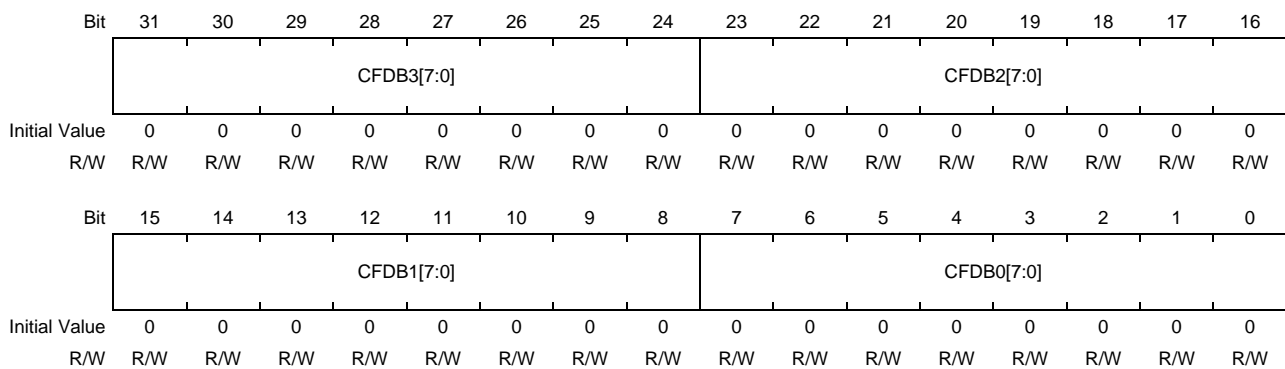

Bit	Bit Name	Initial Value	R/W	Description
31 to 24	CFDB3[7:0]	All 0	R/W	Transmit/Receive FIFO Buffer Data Byte 3
23 to 16	CFDB2[7:0]	All 0	R/W	Transmit/Receive FIFO Buffer Data Byte 2
15 to 8	CFDB1[7:0]	All 0	R/W	Transmit/Receive FIFO Buffer Data Byte 1
7 to 0	CFDB0[7:0]	All 0	R/W	Transmit/Receive FIFO Buffer Data Byte 0 <ul style="list-style-type: none"> • When CFM[1:0] value is 01b (transmit mode): Set the transmit/receive FIFO buffer data. • When CFM[1:0] value is 00b (receive mode): The message data stored in the transmit/receive FIFO buffer can be read.

This register is writable only when the CFM[1:0] value in the RSCANnCFCCk register is 01b (transmit mode). This register is readable only when the CFM[1:0] value is 00b (receive mode). When the CFDLC[3:0] value in the RSCANnCFPTRk register is smaller than 1000b, data bytes for which no data is set are read as H'00.

This register should not be read or written when the CFM[1:0] value is 10b (gateway mode).

28.3.8.7 RSCANnCFDF1_k — Transmit/receive FIFO Buffer Access Data Field 1 Register (k = 0 to 5)

Access Size: RSCANnCFDF1_k register can be read/written in 32-bit units
 RSCANnCFDF1_kL, RSCANnCFDF1_kH registers can be read/written in 16-bit units
 RSCANnCFDF1_kLL, RSCANnCFDF1_kLH, RSCANnCFDF1_kHL, RSCANnCFDF1_kHH registers can be read/written in 8-bit units

Address(es): RSCANnCFDF1_k: <RSCFDn_base> + H'0E8C + (H'10 × k)
 RSCANnCFDF1_kL: <RSCFDn_base> + H'0E8C + (H'10 × k),
 RSCANnCFDF1_kH: <RSCFDn_base> + H'0E8E + (H'10 × k)
 RSCANnCFDF1_kLL: <RSCFDn_base> + H'0E8C + (H'10 × k),
 RSCANnCFDF1_kLH: <RSCFDn_base> + H'0E8D + (H'10 × k),
 RSCANnCFDF1_kHL: <RSCFDn_base> + H'0E8E + (H'10 × k),
 RSCANnCFDF1_kHH: <RSCFDn_base> + H'0E8F + (H'10 × k)

Initial Value: H'0000 0000

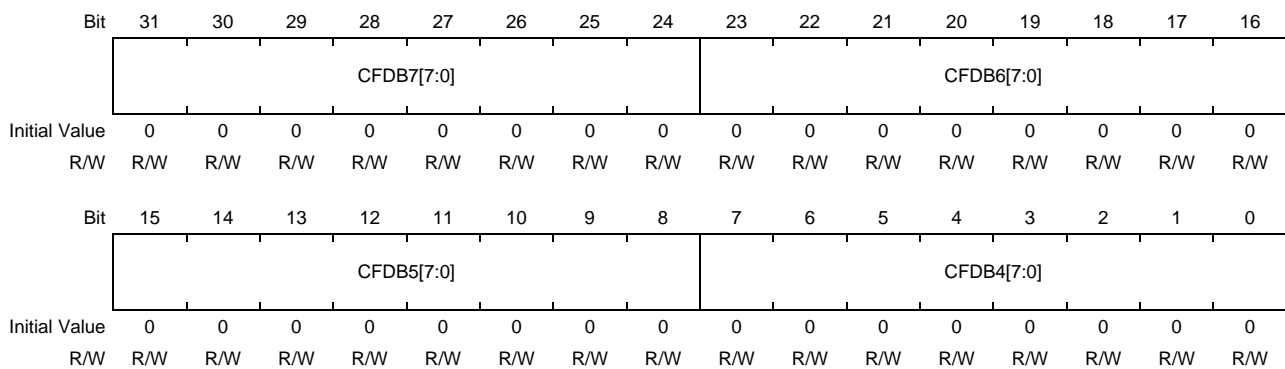

Bit	Bit Name	Initial Value	R/W	Description
31 to 24	CFDB7[7:0]	All 0	R/W	Transmit/Receive FIFO Buffer Data Byte 7
23 to 16	CFDB6[7:0]	All 0	R/W	Transmit/Receive FIFO Buffer Data Byte 6
15 to 8	CFDB5[7:0]	All 0	R/W	Transmit/Receive FIFO Buffer Data Byte 5
7 to 0	CFDB4[7:0]	All 0	R/W	Transmit/Receive FIFO Buffer Data Byte 4 <ul style="list-style-type: none"> • When CFM[1:0] value is 01b (transmit mode): Set the transmit/receive FIFO buffer data. • When CFM[1:0] value is 00b (receive mode): The message data stored in the transmit/receive FIFO buffer can be read.

This register is writable only when the CFM[1:0] value in the RSCANnCFCCk register is 01b (transmit mode). This register is readable only when the CFM[1:0] value is 00b (receive mode). When the CFDLc[3:0] value in the RSCANnCFPTRk register is smaller than 1000b, data bytes for which no data is set are read as H'00.

This register should not be read or written when the CFM[1:0] value is 10b (gateway mode).

28.3.9 Details of FIFO Status-related Registers

28.3.9.1 RSCANnFESTS — FIFO Empty Status Register

Access Size: RSCANnFESTS register can be read only in 32-bit units
 RSCANnFESTSL, RSCANnFESTSH registers can be read only in 16-bit units
 RSCANnFESTSLL, RSCANnFESTSLH, RSCANnFESTSHL, RSCANnFESTSHH registers can be read only in 8-bit units

Address(es): RSCANnFESTS: <RSCFDn_base> + H'0238
 RSCANnFESTSL: <RSCFDn_base> + H'0238, RSCANnFESTSH: <RSCFDn_base> + H'023A
 RSCANnFESTSLL: <RSCFDn_base> + H'0238, RSCANnFESTSLH: <RSCFDn_base> + H'0239,
 RSCANnFESTSHL: <RSCFDn_base> + H'023A, RSCANnFESTSHH: <RSCFDn_base> + H'023B

Initial Value: H'03FF FFFF

Bit	31	30	29	28	27	26	25	24	23	22	21	20	19	18	17	16
	—	—	—	—	—	—	—	—	—	—	—	—	—	—	—	—
Initial Value	0	0	0	0	0	0	1	1	1	1	1	1	1	1	1	1
R/W	R	R	R	R	R	R	R	R	R	R	R	R	R	R	R	R
Bit	15	14	13	12	11	10	9	8	7	6	5	4	3	2	1	0
	—	—	CF5EMP	CF4EMP	CF3EMP	CF2EMP	CF1EMP	CF0EMP	RF7EMP	RF6EMP	RF5EMP	RF4EMP	RF3EMP	RF2EMP	RF1EMP	RF0EMP
			P	P	P	P	P	P	P	P	P	P	P	P	P	P
Initial Value	1	1	1	1	1	1	1	1	1	1	1	1	1	1	1	1
R/W	R	R	R	R	R	R	R	R	R	R	R	R	R	R	R	R

Bit	Bit Name	Initial Value	R/W	Description
31 to 14	—	H'0_0FFF	R	Reserved These bits are read as the value after reset.
13	CF5EMP	1	R	Transmit/Receive FIFO Buffer Empty Status Flag 0: Transmit/receive FIFO buffer k contains a message. 1: Transmit/receive FIFO buffer k contains no message. (k = 0 to 5)
12	CF4EMP	1	R	
11	CF3EMP	1	R	
10	CF2EMP	1	R	
9	CF1EMP	1	R	
8	CF0EMP	1	R	
7	RF7EMP	1	R	Receive FIFO Buffer Empty Status Flag 0: Receive FIFO buffer x contains a unread messages. 1: Receive FIFO buffer x contains no unread message. (x = 0 to 7)
6	RF6EMP	1	R	
5	RF5EMP	1	R	
4	RF4EMP	1	R	
3	RF3EMP	1	R	
2	RF2EMP	1	R	
1	RF1EMP	1	R	
0	RF0EMP	1	R	

The RSCANnFESTS register is set to H'03FF FFFF in global reset mode.

CFkEMP Flag (k = 0 to 5)

The CFkEMP flag is set to 1 when the CFEMP flag in the RSCANnCFSTSk register is set to 1 (the transmit/receive FIFO buffer contains no message (buffer empty)). When the CFEMP flag is cleared to 0 (the transmit/receive FIFO buffer contains messages), the CFkEMP flag is cleared to 0.

RFxEMP Flag (x = 0 to 7)

The RFxEMP flag is set to 1 when the RFEMP flag in the RSCANnRFSTStx register is set to 1 (the receive FIFO buffer contains no unread message). When the RFEMP flag is cleared to 0 (the receive FIFO buffer contains unread messages), the RFxEMP flag is cleared to 0.

28.3.9.2 RSCANnFFSTS — FIFO Full Status Register

Access Size: RSCANnFFSTS register can be read only in 32-bit units
 RSCANnFFSTSL, RSCANnFFSTSH registers can be read only in 16-bit units
 RSCANnFFSTSLL, RSCANnFFSTSLH, RSCANnFFSTSHL, RSCANnFFSTSHH registers can be read only in 8-bit units

Address(es): RSCANnFFSTS: <RSCFDn_base> + H'023C
 RSCANnFFSTSL: <RSCFDn_base> + H'023C, RSCANnFFSTSH: <RSCFDn_base> + H'023E
 RSCANnFFSTSLL: <RSCFDn_base> + H'023C, RSCANnFFSTSLH: <RSCFDn_base> + H'023D,
 RSCANnFFSTSHL: <RSCFDn_base> + H'023E, RSCANnFFSTSHH: <RSCFDn_base> + H'023F

Initial Value: H'0000 0000

Bit	31	30	29	28	27	26	25	24	23	22	21	20	19	18	17	16
	—	—	—	—	—	—	—	—	—	—	—	—	—	—	—	—
Initial Value	0	0	0	0	0	0	0	0	0	0	0	0	0	0	0	0
R/W	R	R	R	R	R	R	R	R	R	R	R	R	R	R	R	R
Bit	15	14	13	12	11	10	9	8	7	6	5	4	3	2	1	0
	—	—	CF5FLL	CF4FLL	CF3FLL	CF2FLL	CF1FLL	CF0FLL	RF7FLL	RF6FLL	RF5FLL	RF4FLL	RF3FLL	RF2FLL	RF1FLL	RF0FLL
Initial Value	0	0	0	0	0	0	0	0	0	0	0	0	0	0	0	0
R/W	R	R	R	R	R	R	R	R	R	R	R	R	R	R	R	R

Bit	Bit Name	Initial Value	R/W	Description
31 to 14	—	All 0	R	Reserved These bits are read as the value after reset.
13	CF5FLL	0	R	Transmit/Receive FIFO Buffer Full Status Flag 0: Transmit/receive buffer k is not full. 1: Transmit/receive buffer k is full. (k = 0 to 5)
12	CF4FLL	0	R	
11	CF3FLL	0	R	
10	CF2FLL	0	R	
9	CF1FLL	0	R	
8	CF0FLL	0	R	
7	RF7FLL	0	R	Receive FIFO Buffer Full Status Flag 0: Receive FIFO buffer x is not full. 1: Receive FIFO buffer x is full. (x = 0 to 7)
6	RF6FLL	0	R	
5	RF5FLL	0	R	
4	RF4FLL	0	R	
3	RF3FLL	0	R	
2	RF2FLL	0	R	
1	RF1FLL	0	R	
0	RF0FLL	0	R	

The RSCANnFFSTS register is cleared to H'0000 0000 in global reset mode.

CFkFLL Flag (k = 0 to 5)

The CFkFLL flag is set to 1 when the CFFLL flag in the RSCANnCFSTSk register is set to 1 (the transmit/receive FIFO buffer is full).

When the CFFLL flag is cleared to 0 (the transmit/receive FIFO buffer is not full), the CFkFLL flag is cleared to 0.

RFxFLl Flag (x = 0 to 7)

The RFxFLl flag is set to 1 when the RFFLL flag in the RSCANnRFSTSx register is set to 1 (the receive FIFO buffer is full). When the RFFLL flag is cleared to 0 (the receive FIFO buffer is not full), the RFxFLl flag is cleared to 0.

28.3.9.3 RSCANnFMSTS — FIFO Message Lost Status Register

Access Size: RSCANnFMSTS register can be read only in 32-bit units
 RSCANnFMSTSL, RSCANnFMSTSH registers can be read only in 16-bit units
 RSCANnFMSTSLL, RSCANnFMSTSLH, RSCANnFMSTSHL, RSCANnFMSTSHH registers can be read only in 8-bit units

Address(es): RSCANnFMSTS: <RSCFDn_base> + H'0240
 RSCANnFMSTSL: <RSCFDn_base> + H'0240, RSCANnFMSTSH: <RSCFDn_base> + H'0242
 RSCANnFMSTSLL: <RSCFDn_base> + H'0240, RSCANnFMSTSLH: <RSCFDn_base> + H'0241,
 RSCANnFMSTSHL: <RSCFDn_base> + H'0242, RSCANnFMSTSHH: <RSCFDn_base> + H'0243

Initial Value: H'0000 0000

Bit	31	30	29	28	27	26	25	24	23	22	21	20	19	18	17	16
	—	—	—	—	—	—	—	—	—	—	—	—	—	—	—	—
Initial Value	0	0	0	0	0	0	0	0	0	0	0	0	0	0	0	0
R/W	R	R	R	R	R	R	R	R	R	R	R	R	R	R	R	R
Bit	15	14	13	12	11	10	9	8	7	6	5	4	3	2	1	0
	—	—	CF5MLT	CF4MLT	CF3MLT	CF2MLT	CF1MLT	CF0MLT	RF7MLT	RF6MLT	RF5MLT	RF4MLT	RF3MLT	RF2MLT	RF1MLT	RF0MLT
Initial Value	0	0	0	0	0	0	0	0	0	0	0	0	0	0	0	0
R/W	R	R	R	R	R	R	R	R	R	R	R	R	R	R	R	R

Bit	Bit Name	Initial Value	R/W	Description
31 to 14	—	All 0	R	Reserved These bits are read as the value after reset.
13	CF5MLT	0	R	Transmit/Receive FIFO Buffer Message Lost Status Flag 0: No transmit/receive FIFO buffer k message is lost. 1: A transmit/receive FIFO buffer k message is lost. (k = 0 to 5)
12	CF4MLT	0	R	
11	CF3MLT	0	R	
10	CF2MLT	0	R	
9	CF1MLT	0	R	
8	CF0MLT	0	R	
7	RF7MLT	0	R	Receive FIFO Buffer Message Lost Status Flag 0: No receive FIFO buffer x message is lost. 1: A receive FIFO buffer x message is lost. (x = 0 to 7)
6	RF6MLT	0	R	
5	RF5MLT	0	R	
4	RF4MLT	0	R	
3	RF3MLT	0	R	
2	RF2MLT	0	R	
1	RF1MLT	0	R	
0	RF0MLT	0	R	

The RSCANnFMSTS register is cleared to H'0000 0000 in global reset mode.

CFkMLT Flag (k = 0 to 5)

The CFkMLT flag is set to 1 when the CFMLT flag in the RSCANnCFSTSk register is set to 1 (a transmit/receive FIFO message is lost). When the CFMLT flag is cleared to 0, the CFkMLT flag is cleared to 0.

RFxMLT Flag (x = 0 to 7)

The RFxMLT flag is set to 1 when the RFMLT flag in the RSCANnRFSTSx register is set to 1 (a receive FIFO message is lost). When the RFMLT flag is cleared to 0, the RFxMLT flag is cleared to 0.

28.3.9.4 RSCANnRFISTS — Receive FIFO Buffer Interrupt Flag Status Register

Access Size: RSCANnRFISTS register can be read only in 32-bit units
RSCANnRFISTS_{SL}, RSCANnRFISTS_{SH} registers can be read only in 16-bit units
RSCANnRFISTS_{SL}_L, RSCANnRFISTS_{SL}_H, RSCANnRFISTS_{SH}_L, RSCANnRFISTS_{SH}_H registers can be read only in 8-bit units

Address(es): RSCANnRFISTS: <RSCFDn_base> + H'0244
RSCANnRFISTS_{SL}: <RSCFDn_base> + H'0244, RSCANnRFISTS_{SH}: <RSCFDn_base> + H'0246
RSCANnRFISTS_{SL}_L: <RSCFDn_base> + H'0244, RSCANnRFISTS_{SL}_H: <RSCFDn_base> + H'0245,
RSCANnRFISTS_{SH}_L: <RSCFDn_base> + H'0246, RSCANnRFISTS_{SH}_H: <RSCFDn_base> + H'0247

Initial Value: H'0000 0000

Bit	31	30	29	28	27	26	25	24	23	22	21	20	19	18	17	16
	—	—	—	—	—	—	—	—	—	—	—	—	—	—	—	—
Initial Value	0	0	0	0	0	0	0	0	0	0	0	0	0	0	0	0
R/W	R	R	R	R	R	R	R	R	R	R	R	R	R	R	R	R
Bit	15	14	13	12	11	10	9	8	7	6	5	4	3	2	1	0
	—	—	—	—	—	—	—	—	RF7IF	RF6IF	RF5IF	RF4IF	RF3IF	RF2IF	RF1IF	RF0IF
Initial Value	0	0	0	0	0	0	0	0	0	0	0	0	0	0	0	0
R/W	R	R	R	R	R	R	R	R	R	R	R	R	R	R	R	R

Bit	Bit Name	Initial Value	R/W	Description
31 to 8	—	All 0	R	Reserved These bits are read as the value after reset.
7	RF7IF	0	R	Receive FIFO Buffer Interrupt Request Status Flag 0: No receive FIFO buffer x interrupt request is present. 1: A receive FIFO buffer x interrupt request is present. (x = 0 to 7)
6	RF6IF	0	R	
5	RF5IF	0	R	
4	RF4IF	0	R	
3	RF3IF	0	R	
2	RF2IF	0	R	
1	RF1IF	0	R	
0	RF0IF	0	R	

The RSCANnRFISTS register is cleared to H'0000 0000 in global reset mode.

RFxIF Flag (x = 0 to 7)

The RFxIF flag is set to 1 when the RFIF flag in the RSCANnRFISTS_x register is set to 1 (a receive FIFO interrupt request is present). When the RFIF flag is cleared to 0, the RFxIF flag is cleared to 0.

28.3.9.5 RSCANnCFRISTS — Transmit/receive FIFO Buffer Receive Interrupt Flag Status Register

Access Size: RSCANnCFRISTS register can be read only in 32-bit units
RSCANnCFRISTS_{SL}, RSCANnCFRISTS_{SH} registers can be read only in 16-bit units
RSCANnCFRISTS_{SLL}, RSCANnCFRISTS_{SLH}, RSCANnCFRISTS_{SHL}, RSCANnCFRISTS_{SHH} registers can be read only in 8-bit units

Address(es): RSCANnCFRISTS: <RSCFDn_base> + H'0248
RSCANnCFRISTS_{SL}: <RSCFDn_base> + H'0248, RSCANnCFRISTS_{SH}: <RSCFDn_base> + H'024A
RSCANnCFRISTS_{SLL}: <RSCFDn_base> + H'0248, RSCANnCFRISTS_{SLH}: <RSCFDn_base> + H'0249,
RSCANnCFRISTS_{SHL}: <RSCFDn_base> + H'024A, RSCANnCFRISTS_{SHH}: <RSCFDn_base> + H'024B

Initial Value: H'0000 0000

Bit	31	30	29	28	27	26	25	24	23	22	21	20	19	18	17	16
	—	—	—	—	—	—	—	—	—	—	—	—	—	—	—	—
Initial Value	0	0	0	0	0	0	0	0	0	0	0	0	0	0	0	0
R/W	R	R	R	R	R	R	R	R	R	R	R	R	R	R	R	R
Bit	15	14	13	12	11	10	9	8	7	6	5	4	3	2	1	0
	—	—	—	—	—	—	—	—	—	—	CF5RXIF	CF4RXIF	CF3RXIF	CF2RXIF	CF1RXIF	CF0RXIF
											F	F	F	F	F	F
Initial Value	0	0	0	0	0	0	0	0	0	0	0	0	0	0	0	0
R/W	R	R	R	R	R	R	R	R	R	R	R	R	R	R	R	R

Bit	Bit Name	Initial Value	R/W	Description
31 to 6	—	All 0	R	Reserved These bits are read as the value after reset.
5	CF5RXIF	0	R	Transmit/Receive FIFO Buffer Receive Interrupt Request Status Flag 0: No transmit/receive FIFO buffer k receive interrupt request is present. 1: A transmit/receive FIFO buffer k receive interrupt request is present. (k = 0 to 5)
4	CF4RXIF	0	R	
3	CF3RXIF	0	R	
2	CF2RXIF	0	R	
1	CF1RXIF	0	R	
0	CF0RXIF	0	R	

The RSCANnCFRISTS register is cleared to H'0000 0000 in global reset mode.

CFkRXIF Flag (k = 0 to 5)

The CFkRXIF flag is set to 1 when the CFRXIF flag in the RSCANnCFSTSk register is set to 1 (a transmit/receive FIFO receive interrupt request is present). When the CFRXIF flag is cleared to 0, the CFkRXIF flag is cleared to 0.

28.3.9.6 RSCANnCFSTISTS — Transmit/receive FIFO Buffer Transmit Interrupt Flag Status Register

Access Size: RSCANnCFSTISTS register can be read only in 32-bit units
 RSCANnCFSTISTS_{SL}, RSCANnCFSTISTS_{SH} registers can be read only in 16-bit units
 RSCANnCFSTISTS_{SLL}, RSCANnCFSTISTS_{SLH}, RSCANnCFSTISTS_{SHL}, RSCANnCFSTISTS_{SHH} registers can be read only in 8-bit units

Address(es): RSCANnCFSTISTS: <RSCFDn_base> + H'024C
 RSCANnCFSTISTS_{SL}: <RSCFDn_base> + H'024C, RSCANnCFSTISTS_{SH}: <RSCFDn_base> + H'024E
 RSCANnCFSTISTS_{SLL}: <RSCFDn_base> + H'024C, RSCANnCFSTISTS_{SLH}: <RSCFDn_base> + H'024D,
 RSCANnCFSTISTS_{SHL}: <RSCFDn_base> + H'024E, RSCANnCFSTISTS_{SHH}: <RSCFDn_base> + H'024F

Initial Value: H'0000 0000

Bit	31	30	29	28	27	26	25	24	23	22	21	20	19	18	17	16
	—	—	—	—	—	—	—	—	—	—	—	—	—	—	—	—
Initial Value	0	0	0	0	0	0	0	0	0	0	0	0	0	0	0	0
R/W	R	R	R	R	R	R	R	R	R	R	R	R	R	R	R	R
Bit	15	14	13	12	11	10	9	8	7	6	5	4	3	2	1	0
	—	—	—	—	—	—	—	—	—	—	CF5TXIF	CF4TXIF	CF3TXIF	CF2TXIF	CF1TXIF	CF0TXIF
Initial Value	0	0	0	0	0	0	0	0	0	0	0	0	0	0	0	0
R/W	R	R	R	R	R	R	R	R	R	R	R	R	R	R	R	R

Bit	Bit Name	Initial Value	R/W	Description
31 to 6	—	All 0	R	Reserved These bits are read as the value after reset.
5	CF5TXIF	0	R	Transmit/Receive FIFO Buffer Transmit Interrupt Request Status Flag 0: No transmit/receive FIFO buffer k transmit interrupt request is present. 1: A transmit/receive FIFO buffer k transmit interrupt request is present. (k = 0 to 5)
4	CF4TXIF	0	R	
3	CF3TXIF	0	R	
2	CF2TXIF	0	R	
1	CF1TXIF	0	R	
0	CF0TXIF	0	R	

The RSCANnCFSTISTS register is cleared to H'0000 0000 in global reset mode.

CFkTXIF Flag (k = 0 to 5)

The CFkTXIF flag is set to 1 when the CFTXIF flag in the RSCANnCFSTIS_k register is set to 1 (a transmit/receive FIFO transmit interrupt request is present). When the CFTXIF flag is cleared to 0, the CFkTXIF flag is cleared to 0.

28.3.10 Details of Transmit Buffer-related Registers

28.3.10.1 RSCANnTMCp — Transmit Buffer Control Register (p = 0 to 31)

Access Size: RSCANnTMCp registers can be read/written in 8-bit units

Address(es): RSCANnTMCp: <RSCFDn_base> + H'0250 + (H'01 × p)

Initial Value: H'00

Bit	7	6	5	4	3	2	1	0
	—	—	—	—	—	TMOM	TMTAR	TMTR
Initial Value	0	0	0	0	0	0	0	0
R/W	R	R	R	R	R	R/W	R/W*1	R/W*1

Bit	Bit Name	Initial Value	R/W	Description
7 to 3	—	All 0	R	Reserved These bits are read as the value after reset. The write value should be the value after reset.
2	TMOM	0	R/W	One-Shot Transmission Enable 0: One-shot transmission is disabled. 1: One-shot transmission is enabled.
1	TMTAR	0	R/W*1	Transmit Abort Request 0: Transmit abort is not requested. 1: Transmit abort is requested.
0	TMTR	0	R/W*1	Transmit Request 0: Transmission is not requested. 1: Transmission is requested.

Note 1. The only effective value for writing to this bit is 1, which sets the bit. Otherwise writing to the bit results in retention of its state.

When the RSCANnTMCp register meets any of the following conditions, set it to H'00.

- The RSCANnTMCp register corresponds to the transmit buffer number selected by the CFTML[3:0] bits in the RSCANnCFCCk register ($p = m \times 16 + \text{the value of CFTML}[3:0] \text{ bits}$).
- The RSCANnTMCp register corresponds to the transmit buffer allocated to the transmit queue by the TXQDC[3:0] bits in the RSCANnTXQCCm ($m = 0, 1$) register ($p = (m \times 16 + 15) \text{ to } (m \times 16 + 15 - \text{the value of TXQDC}[3:0] \text{ bits})$).

Bits in the RSCANnTMCp register are all cleared to 0 in channel reset mode. Modify the RSCANnTMCp register in channel communication mode or channel halt mode.

TMOM Bit

Setting this bit to 1 enables one-shot transmission. When transmission fails, retransmission defined in the CAN protocol is not performed.

Modify the TMOM bit when the TMTRM flag in the RSCANnTMSTSp register is set to 0. Set the TMOM bit to 1 together with the TMTR bit.

TMTAR Bit

Setting this bit to 1 generates a transmit abort request for the message stored in the transmit buffer. However, a message that is being transmitted or one that will be transmitted next cannot be aborted.

The TMTAR bit can be set to 1 when TMTR bit is 1.

The TMTAR bit is cleared to 0 when any of the following conditions is met, but cannot be cleared by the program writing 0 to the bit.

- Transmission has been completed.
- Transmit abort has been completed.
- An error or arbitration loss has been detected.

If this bit becomes 0 at the same time as the program writes 1 to this bit, this bit becomes 0.

TMTR Bit

Setting this bit to 1 transmits the message stored in the transmit buffer.

The TMTR bit is cleared to 0 when any of the following conditions is met, but cannot be cleared by the program writing 0 to the bit.

- Transmission has been completed.
- Transmit abort has been completed after the TMTAR bit was set to 1.
- An error or arbitration-lost has been detected with the TMOM bit set to 1.

Set the TMTR bit to 1 when the value of TMTRF[1:0] in the RSCANnTMSTSp register is 00b.

28.3.10.2 RSCANnTMSTSp — Transmit Buffer Status Register (p = 0 to 31)

Access Size: RSCANnTMSTSp registers can be read/written in 8-bit units

Address(es): RSCANnTMSTSp: <RSCFDn_base> + H'02D0 + (H'01 × p)

Initial Value: H'00

Bit	7	6	5	4	3	2	1	0
	—	—	—	TMTAR M	TMTRM	TMTRF[1:0]		TMTST S
Initial Value	0	0	0	0	0	0	0	0
R/W	R	R	R	R	R	R/W	R/W	R

Bit	Bit Name	Initial Value	R/W	Description
7 to 5	—	All 0	R	Reserved These bits are read as the value after reset. The write value should be the value after reset.
4	TMTARM	0	R	Transmit Buffer Transmit Abort Request Status Flag 0: No transmit abort request is present. 1: A transmit abort request is present.
3	TMTRM	0	R	Transmit Buffer Transmit Request Status Flag 0: No transmit request is present. 1: A transmit request is present.
2, 1	TMTRF[1:0]	All 0	R/W	Transmit Buffer Transmit Result Status Flag b2 b1 0 0: Transmission is in progress or no transmit request is present. 0 1: Transmit abort has been completed. 1 0: Transmission has been completed (without transmit abort request). 1 1: Transmission has been completed (with transmit abort request).
0	TMTSTS	0	R	Transmit Buffer Transmit Status Flag 0: Transmission is not in progress. 1: Transmission is in progress.

The RSCANnTMSTSp register is cleared to all 0 in channel reset mode.

TMTARM Flag

The TMTARM flag is set to 1 when the TMTAR bit in the RSCANnTMCp register is set to 1.

The TMTARM flag is set to 0 when the TMTAR bit in the RSCANnTMCp register is set to 0.

TMTRM Flag

The TMTRM flag is set to 1 when the TMTR bit in the RSCANnTMCp register is set to 1.

The TMTRM flag is set to 0 when the TMTR bit in the RSCANnTMCp register is set to 0.

TMTRF[1:0] Flag

This flag indicates the result of transmission from the transmit buffer.

00b: Transmission is in progress or no transmit request is present.

01b: Transmission from the transmit buffer was aborted.

10b: Transmission has been completed with the TMTAR bit in the RSCANnTMCp register set to 0 (transmit abort is not requested).

11b: Transmission has been completed with the TMTAR bit in the RSCANnTMCp register set to 1 (transmit abort is requested).

Write 00b to the TMTRF[1:0] flag in channel communication mode or channel halt mode. Do not write any value other than 00b to this flag.

TMTSTS Flag

This flag is set to 1 when transmission from the transmit buffer starts, and is cleared to 0 when transmission from the transmit buffer has been completed or terminated due to a bus error or arbitration lost.

28.3.10.3 RSCANnTMIDp — Transmit Buffer ID Register (p = 0 to 31)

Access Size: RSCANnTMIDp register can be read/written in 32-bit units
 RSCANnTMIDpL, RSCANnTMIDpH registers can be read/written in 16-bit units
 RSCANnTMIDpLL, RSCANnTMIDpLH, RSCANnTMIDpHL, RSCANnTMIDpHH registers can be read/written in 8-bit units

Address(es): RSCANnTMIDp: <RSCFDn_base> + H'1000 + (H'10 × p)
 RSCANnTMIDpL: <RSCFDn_base> + H'1000 + (H'10 × p),
 RSCANnTMIDpH: <RSCFDn_base> + H'1002 + (H'10 × p),
 RSCANnTMIDpLL: <RSCFDn_base> + H'1000 + (H'10 × p),
 RSCANnTMIDpLH: <RSCFDn_base> + H'1001 + (H'10 × p),
 RSCANnTMIDpHL: <RSCFDn_base> + H'1002 + (H'10 × p),
 RSCANnTMIDpHH: <RSCFDn_base> + H'1003 + (H'10 × p)

Initial Value: H'0000 0000

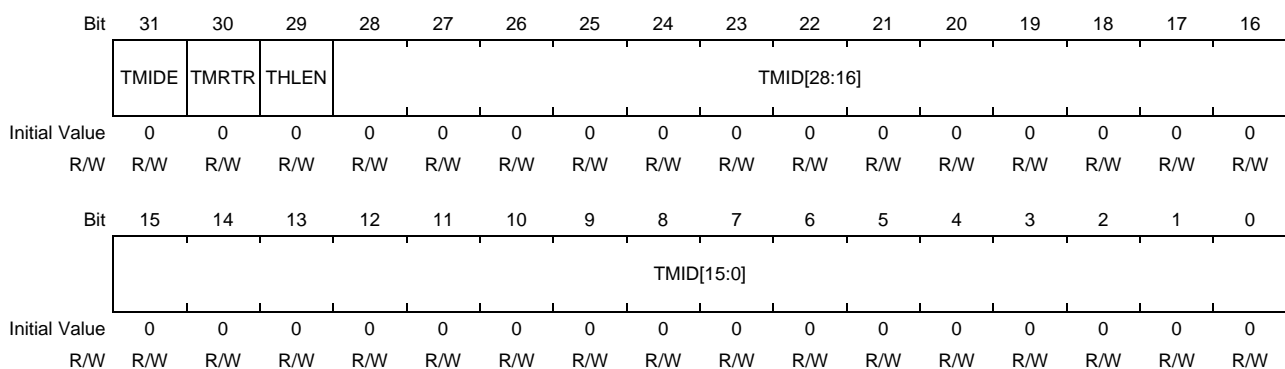

Bit	Bit Name	Initial Value	R/W	Description
31	TMIDE	0	R/W	Transmit Buffer IDE 0: Standard ID 1: Extended ID
30	TMRTR	0	R/W	Transmit Buffer RTR 0: Data frame 1: Remote frame
29	THLEN	0	R/W	Transmit History Data Store Enable 0: Transmit history data is not stored in the buffer. 1: Transmit history data is stored in the buffer.
28 to 0	TMID[28:0]	All 0	R/W	Transmit Buffer ID Data Set standard ID or extended ID. For standard ID, write an ID to bits 10 to 0 and write 0 to bits 28 to 11.

Modify this register when the TMTRM bit in the corresponding RSCANnTMSTSp register is set to 0 (no transmit request is present). If this register is linked to a transmit/receive FIFO buffer, do not write data to this register. If this register is allocated to the transmit queue, only write data to a transmit buffer p (p = m × 16 + 15) for the corresponding channel.

TMIDE Bit

This bit is used to set the ID format of the message to be transmitted from the transmit buffer.

TMRTR Bit

This bit is used to set the data format of the message to be transmitted from the transmit buffer.

THLEN Bit

When this bit is set to 1, the transmit history data (label information, buffer number, buffer type, and timestamp (timestamp is included if the TMTSCE bit in the RSCANnGCFCFG register is 1)) of transmit messages is stored in the transmit history buffer after transmission is completed.

TMID[28:0] Bits

These bits are used to set the ID of the message to be transmitted from the transmit buffer.

28.3.10.4 RSCANnTMPTRp — Transmit Buffer Pointer Register (p = 0 to 31)

Access Size: RSCANnTMPTRp register can be read/written in 32-bit units
 RSCANnTMPTRpL, RSCANnTMPTRpH registers can be read/written in 16-bit units
 RSCANnTMPTRpLL, RSCANnTMPTRpLH, RSCANnTMPTRpHL, RSCANnTMPTRpHH registers can be read/written in 8-bit units

Address(es): RSCANnTMPTRp: <RSCFDn_base> + H'1004 + (H'10 × p)
 RSCANnTMPTRpL: <RSCFDn_base> + H'1004 + (H'10 × p),
 RSCANnTMPTRpH: <RSCFDn_base> + H'1006 + (H'10 × p)
 RSCANnTMPTRpLL: <RSCFDn_base> + H'1004 + (H'10 × p),
 RSCANnTMPTRpLH: <RSCFDn_base> + H'1005 + (H'10 × p),
 RSCANnTMPTRpHL: <RSCFDn_base> + H'1006 + (H'10 × p),
 RSCANnTMPTRpHH: <RSCFDn_base> + H'1007 + (H'10 × p)

Initial Value: H'0000 0000

Bit	31	30	29	28	27	26	25	24	23	22	21	20	19	18	17	16
	TMDLC[3:0]				—	—	—	—	TMPTR[7:0]							
Initial Value	0	0	0	0	0	0	0	0	0	0	0	0	0	0	0	0
R/W	R/W	R/W	R/W	R/W	R	R	R	R	R/W	R/W	R/W	R/W	R/W	R/W	R/W	R/W
Bit	15	14	13	12	11	10	9	8	7	6	5	4	3	2	1	0
	—	—	—	—	—	—	—	—	—	—	—	—	—	—	—	—
Initial Value	0	0	0	0	0	0	0	0	0	0	0	0	0	0	0	0
R/W	R	R	R	R	R	R	R	R	R	R	R	R	R	R	R	R

Bit	Bit Name	Initial Value	R/W	Description
31 to 28	TMDLC[3:0]	All 0	R/W	Transmit Buffer DLC Data b31 b30 b29 b28 0 0 0 0: 0 data bytes 0 0 0 1: 1 data byte 0 0 1 0: 2 data bytes 0 0 1 1: 3 data bytes 0 1 0 0: 4 data bytes 0 1 0 1: 5 data bytes 0 1 1 0: 6 data bytes 0 1 1 1: 7 data bytes 1 X X X: 8 data bytes
27 to 24	—	All 0	R	Reserved These bits are read as the value after reset. The write value should be the value after reset.
23 to 16	TMPTR[7:0]	All 0	R/W	Transmit Buffer Label Data Set the label information to be stored in the transmit history buffer.
15 to 0	—	All 0	R	Reserved These bits are read as the value after reset. The write value should be the value after reset.

Modify this register when the TMTRM bit in the corresponding RSCANnTMSTSp register is set to 0 (no transmit request is present). If this register is linked to a transmit/receive FIFO buffer, do not write to this register. If this register is allocated to the transmit queue, only write to a transmit buffer p (p = m × 16 + 15) for the corresponding channel.

TMDLC[3:0] Bits

These bits are used to set the data length of the message to be transmitted from the transmit buffer when the TMRTR bit in the RSCANnTMIDp register is set to 0 (data frame). If the data length is set to 1001b or more, the transmit data is 8 bytes long.

When the TMRTR bit is set to 1 (remote frame), set the data length of messages to be requested.

TMPTR[7:0] Bits

When message transmission has been completed, the TMPTR[7:0] value is stored in the transmit history buffer.

28.3.10.5 RSCANnTMDF0_p — Transmit Buffer Data Field 0 Register (p = 0 to 31)

Access Size: RSCANnTMDF0_p register can be read/written in 32-bit units
 RSCANnTMDF0_pL, RSCANnTMDF0_pH registers can be read/written in 16-bit units
 RSCANnTMDF0_pLL, RSCANnTMDF0_pLH, RSCANnTMDF0_pHL, RSCANnTMDF0_pHH registers can be read/written in 8-bit units

Address(es): RSCANnTMDF0_p: <RSCFDn_base> + H'1008 + (H'10 × p)
 RSCANnTMDF0_pL: <RSCFDn_base> + H'1008 + (H'10 × p),
 RSCANnTMDF0_pH: <RSCFDn_base> + H'100A + (H'10 × p)
 RSCANnTMDF0_pLL: <RSCFDn_base> + H'1008 + (H'10 × p),
 RSCANnTMDF0_pLH: <RSCFDn_base> + H'1009 + (H'10 × p),
 RSCANnTMDF0_pHL: <RSCFDn_base> + H'100A + (H'10 × p),
 RSCANnTMDF0_pHH: <RSCFDn_base> + H'100B + (H'10 × p)

Initial Value: H'0000 0000

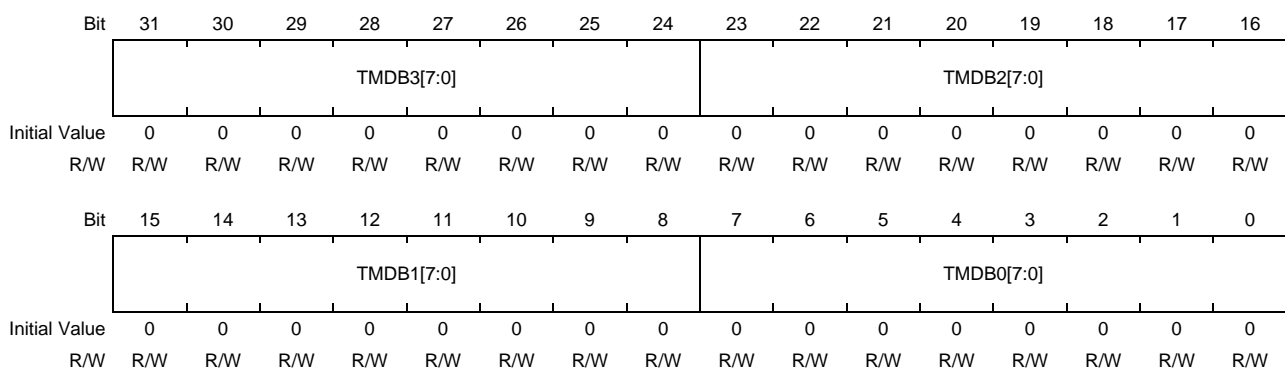

Bit	Bit Name	Initial Value	R/W	Description
31 to 24	TMDB3[7:0]	All 0	R/W	Transmit Buffer Data Byte 3
23 to 16	TMDB2[7:0]	All 0	R/W	Transmit Buffer Data Byte 2
15 to 8	TMDB1[7:0]	All 0	R/W	Transmit Buffer Data Byte 1
7 to 0	TMDB0[7:0]	All 0	R/W	Transmit Buffer Data Byte 0

Set the transmit buffer data.

Modify this register when the TMTRM bit in the corresponding RSCANnTMSTSp register is set to 0 (no transmit request is present). If this register is linked to a transmit/receive FIFO buffer, do not write to this register. If this register is allocated to the transmit queue, only write to a transmit buffer p ($p = m \times 16 + 15$) for the corresponding channel.

28.3.10.6 RSCANnTMDF1_p — Transmit Buffer Data Field 1 Register (p = 0 to 31)

Access Size: RSCANnTMDF1_p register can be read/written in 32-bit units
 RSCANnTMDF1_pL, RSCANnTMDF1_pH registers can be read/written in 16-bit units
 RSCANnTMDF1_pLL, RSCANnTMDF1_pLH, RSCANnTMDF1_pHL, RSCANnTMDF1_pHH registers can be read/written in 8-bit units

Address(es): RSCANnTMDF1_p: <RSCFDn_base> + H'100C + (H'10 × p)
 RSCANnTMDF1_pL: <RSCFDn_base> + H'100C + (H'10 × p),
 RSCANnTMDF1_pH: <RSCFDn_base> + H'100E + (H'10 × p)
 RSCANnTMDF1_pLL: <RSCFDn_base> + H'100C + (H'10 × p),
 RSCANnTMDF1_pLH: <RSCFDn_base> + H'100D + (H'10 × p),
 RSCANnTMDF1_pHL: <RSCFDn_base> + H'100E + (H'10 × p),
 RSCANnTMDF1_pHH: <RSCFDn_base> + H'100F + (H'10 × p)

Initial Value: H'0000 0000

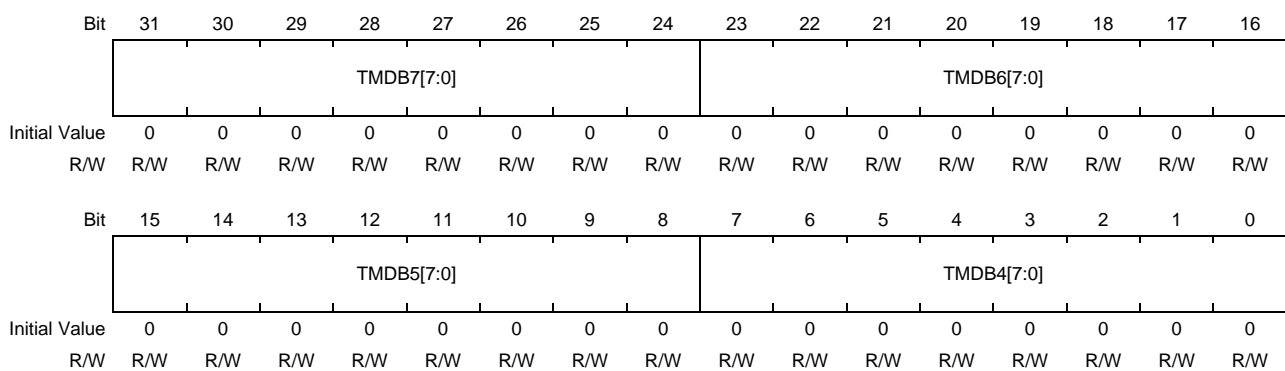

Bit	Bit Name	Initial Value	R/W	Description
31 to 24	TMDB7[7:0]	All 0	R/W	Transmit Buffer Data Byte 7
23 to 16	TMDB6[7:0]	All 0	R/W	Transmit Buffer Data Byte 6
15 to 8	TMDB5[7:0]	All 0	R/W	Transmit Buffer Data Byte 5
7 to 0	TMDB4[7:0]	All 0	R/W	Transmit Buffer Data Byte 4

Set the transmit buffer data.

Modify this register when the TMTRM bit in the corresponding RSCANnTMSTSp register is set to 0 (no transmit request is present). If this register is linked to a transmit/receive FIFO buffer, do not write to this register. If this register is allocated to the transmit queue, only write to a transmit buffer p ($p = m \times 16 + 15$) for the corresponding channel.

28.3.10.7 RSCANnTMIECy — Transmit Buffer Interrupt Enable Configuration Register (y = 0)

Access Size: RSCANnTMIECy register can be read/written in 32-bit units
 RSCANnTMIECyL, RSCANnTMIECyH registers can be read/written in 16-bit units
 RSCANnTMIECyLL, RSCANnTMIECyLH, RSCANnTMIECyHL, RSCANnTMIECyHH registers can be read/written in 8-bit units

Address(es): RSCANnTMIECy: <RSCFDn_base> + H'0390 + (H'04 × y)
 RSCANnTMIECyL: <RSCFDn_base> + H'0390 + (H'04 × y),
 RSCANnTMIECyH: <RSCFDn_base> + H'0392 + (H'04 × y)
 RSCANnTMIECyLL: <RSCFDn_base> + H'0390 + (H'04 × y),
 RSCANnTMIECyLH: <RSCFDn_base> + H'0391 + (H'04 × y),
 RSCANnTMIECyHL: <RSCFDn_base> + H'0392 + (H'04 × y),
 RSCANnTMIECyHH: <RSCFDn_base> + H'0393 + (H'04 × y)

Initial Value: H'0000 0000

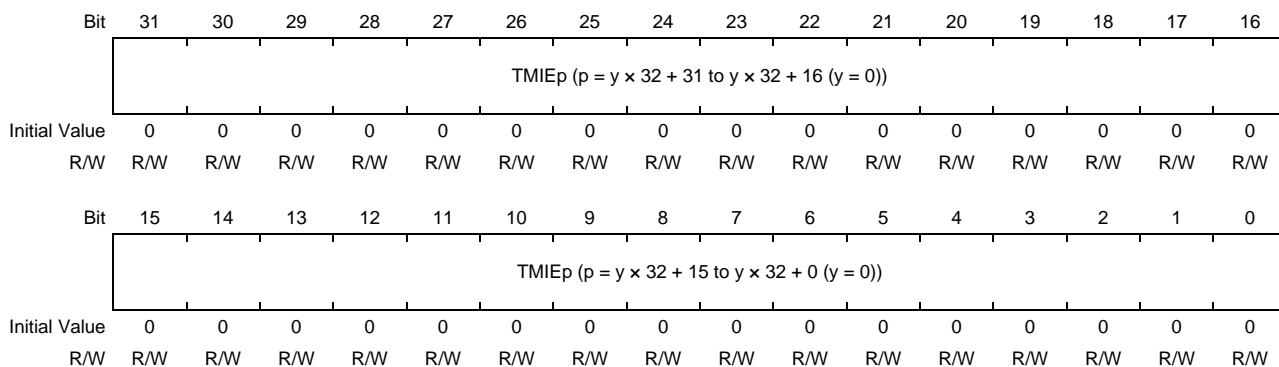

Bit	Bit Name	Initial Value	R/W	Description
31 to 16	TMIEp	All 0	R/W	Transmit Buffer Interrupt Enable p (p = y × 32 + 31 to y × 32 + 16) 0: Transmit buffer interrupt is disabled 1: Transmit buffer interrupt is enabled
15 to 0	TMIEp	All 0	R/W	Transmit Buffer Interrupt Enable p (p = y × 32 + 15 to y × 32 + 0) 0: Transmit buffer interrupt is disabled. 1: Transmit buffer interrupt is enabled.

TMIEp Bits (p = 0 to 31)

When any of these bits is set to 1 and the corresponding transmission has been completed, a transmit buffer interrupt request is generated.

Modify these bits when the TMTRM flag in the corresponding RSCANnTMSTSp register is 0 (no transmit request is present).

Write 0 to bits corresponding to transmit buffers linked to transmit/receive FIFO buffers or transmit buffers allocated to the transmit queue.

Table 28.15 shows the bit assignment.

Table 28.15 TMIEp Bit Assignment

Bit	Channel	Transmit Buffer Number
0	0	0
1	0	1
.	.	.
.	.	.
15	0	15
16	1	0
.	.	.
.	.	.
30	1	14
31	1	15

28.3.11 Details of Transmit Buffer Status-related Registers

28.3.11.1 RSCANnTMTRSTSy — Transmit Buffer Transmit Request Status Register (y = 0)

Access Size: RSCANnTMTRSTSy register can be read only in 32-bit units
 RSCANnTMTRSTSyL, RSCANnTMTRSTSyH registers can be read only in 16-bit units
 RSCANnTMTRSTSyLL, RSCANnTMTRSTSyLH, RSCANnTMTRSTSyHL, RSCANnTMTRSTSyHH registers can be read only in 8-bit units

Address(es): RSCANnTMTRSTSy: <RSCFDn_base> + H'0350 + (H'04 × y)
 RSCANnTMTRSTSyL: <RSCFDn_base> + H'0350 + (H'04 × y),
 RSCANnTMTRSTSyH: <RSCFDn_base> + H'0352 + (H'04 × y)
 RSCANnTMTRSTSyLL: <RSCFDn_base> + H'0350 + (H'04 × y),
 RSCANnTMTRSTSyLH: <RSCFDn_base> + H'0351 + (H'04 × y),
 RSCANnTMTRSTSyHL: <RSCFDn_base> + H'0352 + (H'04 × y),
 RSCANnTMTRSTSyHH: <RSCFDn_base> + H'0353 + (H'04 × y)

Initial Value: H'0000 0000

Bit	31	30	29	28	27	26	25	24	23	22	21	20	19	18	17	16
	TMTRSTSp (p = y × 32 + 31 to y × 32 + 16 (y = 0))															
Initial Value	0	0	0	0	0	0	0	0	0	0	0	0	0	0	0	0
R/W	R	R	R	R	R	R	R	R	R	R	R	R	R	R	R	R
Bit	15	14	13	12	11	10	9	8	7	6	5	4	3	2	1	0
	TMTRSTSp (p = y × 32 + 15 to y × 32 + 0 (y = 0))															
Initial Value	0	0	0	0	0	0	0	0	0	0	0	0	0	0	0	0
R/W	R	R	R	R	R	R	R	R	R	R	R	R	R	R	R	R

Bit	Bit Name	Initial Value	R/W	Description
31 to 16	TMTRSTSp	All 0	R	Transmit Buffer Transmit Request Status Flag p (p = y × 32 + 31 to y × 32 + 16) 0: No transmit request is present. 1: A transmit request is present.
15 to 0	TMTRSTSp	All 0	R	Transmit Buffer Transmit Request Status Flag p (p = y × 32 + 15 to y × 32 + 0) 0: No transmit request is present. 1: A transmit request is present.

TMTRSTSp Flags (p = 0 to 31)

These flags indicate the status of the TMTR bit in the RSCANnTMCp register.

When the TMTR bit is set to 1 (transmission is requested), the corresponding TMTRSTSp flag is set to 1.

The corresponding TMTRSTSp flag is cleared to 0 when the TMTR bit is set to 0 (transmission is not requested) or in channel reset mode.

Table 28.16 shows the bit assignment.

Table 28.16 TMTRSTSp Bit Assignment

Bit	Channel	Transmit Buffer Number
0	0	0
1	0	1
.	.	.
.	.	.
15	0	15
16	1	0
.	.	.
.	.	.
30	1	14
31	1	15

28.3.11.2 RSCANnTMTARSTSy — Transmit Buffer Transmit Abort Request Status Register (y = 0)

Access Size: RSCANnTMTARSTSy register can be read only in 32-bit units
 RSCANnTMTARSTSyL, RSCANnTMTARSTSyH registers can be read only in 16-bit units
 RSCANnTMTARSTSyLL, RSCANnTMTARSTSyLH, RSCANnTMTARSTSyHL, RSCANnTMTARSTSyHH registers can be read only in 8-bit units

Address(es): RSCANnTMTARSTSy: <RSCFDn_base> + H'0360 + (H'04 × y)
 RSCANnTMTARSTSyL: <RSCFDn_base> + H'0360 + (H'04 × y),
 RSCANnTMTARSTSyH: <RSCFDn_base> + H'0362 + (H'04 × y)
 RSCANnTMTARSTSyLL: <RSCFDn_base> + H'0360 + (H'04 × y),
 RSCANnTMTARSTSyLH: <RSCFDn_base> + H'0361 + (H'04 × y),
 RSCANnTMTARSTSyHL: <RSCFDn_base> + H'0362 + (H'04 × y),
 RSCANnTMTARSTSyHH: <RSCFDn_base> + H'0363 + (H'04 × y)

Initial Value: H'0000 0000

Bit	31	30	29	28	27	26	25	24	23	22	21	20	19	18	17	16
	TMTARSTSp (p = y × 32 + 31 to y × 32 + 16 (y = 0))															
Initial Value	0	0	0	0	0	0	0	0	0	0	0	0	0	0	0	0
R/W	R	R	R	R	R	R	R	R	R	R	R	R	R	R	R	R
Bit	15	14	13	12	11	10	9	8	7	6	5	4	3	2	1	0
	TMTARSTSp (p = y × 32 + 15 to y × 32 + 0 (y = 0))															
Initial Value	0	0	0	0	0	0	0	0	0	0	0	0	0	0	0	0
R/W	R	R	R	R	R	R	R	R	R	R	R	R	R	R	R	R

Bit	Bit Name	Initial Value	R/W	Description
31 to 16	TMTARSTSp	All 0	R	Transmit Buffer Transmit Abort Request Status Flag p (p = y × 32 + 31 to y × 32 + 16) 0: No transmit abort request is present. 1: A transmit abort request is present.
15 to 0	TMTARSTSp	All 0	R	Transmit Buffer Transmit Abort Request Status Flag p (p = y × 32 + 15 to y × 32 + 0) 0: No transmit abort request is present. 1: A transmit abort request is present.

TMTARSTSp Flags (p = 0 to 31)

These flags indicate the status of the TMTAR bit in the RSCANnTMCp register.

When the TMTAR bit is set to 1 (transmit abort is requested), the corresponding TMTARSTSp flag is set to 1.

The corresponding TMTARSTSp flag is cleared to 0 when the TMTAR bit is set to 0 (transmit abort is not requested) or in channel reset mode.

Table 28.17 shows the bit assignment.

Table 28.17 TMTARSTSp Bit Assignment

Bit	Channel	Transmit Buffer Number
0	0	0
1	0	1
.	.	.
.	.	.
15	0	15
16	1	0
.	.	.
.	.	.
30	1	14
31	1	15

28.3.11.3 RSCANnTMCSTSy — Transmit Buffer Transmit Complete Status Register (y = 0)

Access Size: RSCFDnTMCSTSyRSCANnTMCSTSy register can be read only in 32-bit units RSCANnTMCSTSyL, RSCANnTMCSTSyH registers can be read only in 16-bit units
RSCANnTMCSTSyLL, RSCANnTMCSTSyLH, RSCANnTMCSTSyHL, RSCANnTMCSTSyHH registers can be read only in 8-bit units

Address(es): RSCANnTMCSTSy: <RSCFDn_base> + H'0370 + (H'04 × y)
RSCANnTMCSTSyL: <RSCFDn_base> + H'0370 + (H'04 × y),
RSCANnTMCSTSyH: <RSCFDn_base> + H'0372 + (H'04 × y)
RSCANnTMCSTSyLL: <RSCFDn_base> + H'0370 + (H'04 × y),
RSCANnTMCSTSyLH: <RSCFDn_base> + H'0371 + (H'04 × y),
RSCANnTMCSTSyHL: <RSCFDn_base> + H'0372 + (H'04 × y),
RSCANnTMCSTSyHH: <RSCFDn_base> + H'0373 + (H'04 × y)

Initial Value: H'0000 0000

Bit	31	30	29	28	27	26	25	24	23	22	21	20	19	18	17	16
	TMCSTSp (p = y × 32 + 31 to y × 32 + 16 (y = 0))															
Initial Value	0	0	0	0	0	0	0	0	0	0	0	0	0	0	0	0
R/W	R	R	R	R	R	R	R	R	R	R	R	R	R	R	R	R
Bit	15	14	13	12	11	10	9	8	7	6	5	4	3	2	1	0
	TMCSTSp (p = y × 32 + 15 to y × 32 + 0 (y = 0))															
Initial Value	0	0	0	0	0	0	0	0	0	0	0	0	0	0	0	0
R/W	R	R	R	R	R	R	R	R	R	R	R	R	R	R	R	R

Bit	Bit Name	Initial Value	R/W	Description
31 to 16	TMCSTSp	All 0	R	Transmit Buffer Transmit Complete Status Flag p (p = y × 32 + 31 to y × 32 + 16) 0: Transmission has not been completed. 1: Transmission has been completed.
15 to 0	TMCSTSp	All 0	R	Transmit Buffer Transmit Complete Status Flag p (p = y × 32 + 15 to y × 32 + 0) 0: Transmission has not been completed. 1: Transmission has been completed.

TMCSTSp Flags (p = 0 to 31)

When the TMTRF[1:0] flag in the RSCANnTMSTSp register is set to 10b (transmission has been completed (without transmit abort request)) or 11b (transmission has been completed (with transmit abort request)), the corresponding TMCSTSp flag is set to 1.

A TMCSTSp flag is cleared to 0 when the corresponding TMTRF[1:0] flag is set to 00b or in channel reset mode.

Table 28.18 shows the bit assignment.

Table 28.18 TMTCSSTp Bit Assignment

Bit	Channel	Transmit Buffer Number
0	0	0
1	0	1
.	.	.
.	.	.
15	0	15
16	1	0
.	.	.
.	.	.
30	1	14
31	1	15

28.3.11.4 RSCANnTMTASTSy — Transmit Buffer Transmit Abort Status Register (y = 0)

Access Size: RSCANnTMTASTSy register can be read only in 32-bit units
 RSCANnTMTASTSyL, RSCANnTMTASTSyH registers can be read only in 16-bit units
 RSCANnTMTASTSyLL, RSCANnTMTASTSyLH, RSCANnTMTASTSyHL, RSCANnTMTASTSyHH registers can be read only in 8-bit units

Address(es): RSCANnTMTASTSy: <RSCFDn_base> + H'0380 + (H'04 × y)
 RSCANnTMTASTSyL: <RSCFDn_base> + H'0380 + (H'04 × y),
 RSCANnTMTASTSyH: <RSCFDn_base> + H'0382 + (H'04 × y)
 RSCANnTMTASTSyLL: <RSCFDn_base> + H'0380 + (H'04 × y),
 RSCANnTMTASTSyLH: <RSCFDn_base> + H'0381 + (H'04 × y),
 RSCANnTMTASTSyHL: <RSCFDn_base> + H'0382 + (H'04 × y),
 RSCANnTMTASTSyHH: <RSCFDn_base> + H'0383 + (H'04 × y)

Initial Value: H'0000 0000

Bit	31	30	29	28	27	26	25	24	23	22	21	20	19	18	17	16
	TMTASTSp (p = y × 32 + 31 to y × 32 + 16 (y = 0))															
Initial Value	0	0	0	0	0	0	0	0	0	0	0	0	0	0	0	0
R/W	R	R	R	R	R	R	R	R	R	R	R	R	R	R	R	R
Bit	15	14	13	12	11	10	9	8	7	6	5	4	3	2	1	0
	TMTASTSp (p = y × 32 + 15 to y × 32 + 0 (y = 0))															
Initial Value	0	0	0	0	0	0	0	0	0	0	0	0	0	0	0	0
R/W	R	R	R	R	R	R	R	R	R	R	R	R	R	R	R	R

Bit	Bit Name	Initial Value	R/W	Description
31 to 16	TMTASTSp	All 0	R	Transmit Buffer Transmit Abort Status Flag p (p = y × 32 + 31 to y × 32 + 16) 0: Transmission is not aborted 1: Transmission is aborted
15 to 0	TMTASTSp	All 0	R	Transmit Buffer Transmit Abort Status Flag p (p = y × 32 + 15 to y × 32 + 0) 0: Transmission is not aborted. 1: Transmission is aborted.

TMTASTSp Flags (p = 0 to 31)

When the TMTRF[1:0] flag in the RSCANnTMSTSp register is set to 01b (transmit abort has been completed), the corresponding TMTASTSp flag is set to 1.

A TMTASTSp flag is cleared to 0 when the corresponding TMTRF[1:0] flag is set to 00b or in channel reset mode.

Table 28.19 shows the bit assignment.

Table 28.19 TMTASTSp Bit Assignment

Bit	Channel	Transmit Buffer Number
0	0	0
1	0	1
.	.	.
.	.	.
15	0	15
16	1	0
.	.	.
.	.	.
30	1	14
31	1	15

28.3.12 Details of Transmit Queue-related Registers

28.3.12.1 RSCANnTXQCCm — Transmit Queue Configuration and Control Register (m = 0, 1)

Access Size: RSCANnTXQCCm register can be read/written in 32-bit units
 RSCANnTXQCCmL, RSCANnTXQCCmH registers can be read/written in 16-bit units
 RSCANnTXQCCmLL, RSCANnTXQCCmLH, RSCANnTXQCCmHL, RSCANnTXQCCmHH registers can be read/written in 8-bit units

Address(es): RSCANnTXQCCm: <RSCFDn_base> + H'03A0 + (H'04 × m)
 RSCANnTXQCCmL: <RSCFDn_base> + H'03A0 + (H'04 × m),
 RSCANnTXQCCmH: <RSCFDn_base> + H'03A2 + (H'04 × m)
 RSCANnTXQCCmLL: <RSCFDn_base> + H'03A0 + (H'04 × m),
 RSCANnTXQCCmLH: <RSCFDn_base> + H'03A1 + (H'04 × m),
 RSCANnTXQCCmHL: <RSCFDn_base> + H'03A2 + (H'04 × m),
 RSCANnTXQCCmHH: <RSCFDn_base> + H'03A3 + (H'04 × m)

Initial Value: H'0000 0000

Bit	31	30	29	28	27	26	25	24	23	22	21	20	19	18	17	16
	—	—	—	—	—	—	—	—	—	—	—	—	—	—	—	—
Initial Value	0	0	0	0	0	0	0	0	0	0	0	0	0	0	0	0
R/W	R	R	R	R	R	R	R	R	R	R	R	R	R	R	R	R
Bit	15	14	13	12	11	10	9	8	7	6	5	4	3	2	1	0
	—	—	TXQIM	TXQIE	TXQDC[3:0]			—	—	—	—	—	—	—	—	TXQE
Initial Value	0	0	0	0	0	0	0	0	0	0	0	0	0	0	0	0
R/W	R	R	R/W	R/W	R/W	R/W	R/W	R/W	R	R	R	R	R	R	R	R/W

Bit	Bit Name	Initial Value	R/W	Description
31 to 14	—	All 0	R	Reserved These bits are read as the value after reset. The write value should be the value after reset.
13	TXQIM	0	R/W	Transmit Queue Interrupt Source Select 0: When the transmit queue becomes empty upon completion of message transmission, a transmit queue interrupt request is generated. 1: A transmit queue interrupt request is generated each time a message has been transmitted.
12	TXQIE	0	R/W	Transmit Queue Interrupt Enable 0: Transmit queue interrupt is disabled. 1: Transmit queue interrupt is enabled.
11 to 8	TXQDC[3:0]	All 0	R/W	Transmit Queue Depth Configuration Setting these bits to g (g = 2 to 15) makes the (g + 1)-buffer transmit queue available. Setting these bits to 0 disables the transmit queue. Setting these bits to 1 is prohibited.
7 to 1	—	All 0	R	Reserved These bits are read as the value after reset. The write value should be the value after reset.
0	TXQE	0	R/W	Transmit Queue Enable 0: The transmit queue is not used. 1: The transmit queue is used.

TXQIM Bit

This bit is used to select a transmit queue interrupt source. Modify this bit in channel reset mode.

TXQIE Bit

When the TXQIE bit is set to 1 and the source selected by the TXQIM bit occurs, an interrupt request is generated. Set the TXQE bit to 0 before modifying the TXQIE bit.

TXQDC[3:0] Bits

These bits are used to specify the number of transmit buffers to be allocated to the transmit queues. Transmit buffers are allocated to transmit queues in descending order of buffer number, that is, from $(m \times 16 + 15)$ to $(m \times 16 + 0)$. For examples of how buffer allocation is done, see **Figure 28.9**. Modify these bits only in channel reset mode.

TXQE Bit

Setting this bit to 1 makes the transmit queue available. Modify this bit in channel communication mode or channel halt mode. This bit is cleared to 0 in channel reset mode.

Before setting the TXQE bit to 1, set the TXQDC[3:0] bits to 0010b or more.

28.3.12.2 RSCANnTXQSTSm — Transmit Queue Status Register (m = 0, 1)

Access Size: RSCANnTXQSTSm register can be read/written in 32-bit units
 RSCANnTXQSTSmL, RSCANnTXQSTSmH registers can be read/written in 16-bit units
 RSCANnTXQSTSmLL, RSCANnTXQSTSmLH, RSCANnTXQSTSmHL, RSCANnTXQSTSmHH registers can be read/written in 8-bit units

Address(es): RSCANnTXQSTSm: <RSCFDn_base> + H'03C0 + (H'04 × m)
 RSCANnTXQSTSmL: <RSCFDn_base> + H'03C0 + (H'04 × m),
 RSCANnTXQSTSmH: <RSCFDn_base> + H'03C2 + (H'04 × m)
 RSCANnTXQSTSmLL: <RSCFDn_base> + H'03C0 + (H'04 × m),
 RSCANnTXQSTSmLH: <RSCFDn_base> + H'03C1 + (H'04 × m),
 RSCANnTXQSTSmHL: <RSCFDn_base> + H'03C2 + (H'04 × m),
 RSCANnTXQSTSmHH: <RSCFDn_base> + H'03C3 + (H'04 × m)

Initial Value: H'0000 0001

Bit	31	30	29	28	27	26	25	24	23	22	21	20	19	18	17	16
	—	—	—	—	—	—	—	—	—	—	—	—	—	—	—	—
Initial Value	0	0	0	0	0	0	0	0	0	0	0	0	0	0	0	0
R/W	R	R	R	R	R	R	R	R	R	R	R	R	R	R	R	R
Bit	15	14	13	12	11	10	9	8	7	6	5	4	3	2	1	0
	—	—	—	—	—	—	—	—	—	—	—	—	—	TXQIF	TXQFLL	TXQEMP
Initial Value	0	0	0	0	0	0	0	0	0	0	0	0	0	0	0	1
R/W	R	R	R	R	R	R	R	R	R	R	R	R	R	R/W*1	R	R

Bit	Bit Name	Initial Value	R/W	Description
31 to 13	—	All 0	R	Reserved These bits are read as the value after reset. The write value should be the value after reset.
12 to 8	—	All 0	R	Reserved When read, an undefined value is returned. The write value should be the value after reset.
7 to 3	—	All 0	R	Reserved These bits are read as the value after reset. The write value should be the value after reset.
2	TXQIF	0	R/W*1	Transmit Queue Interrupt Request Flag 0: No transmit queue interrupt request is present. 1: A transmit queue interrupt request is present.
1	TXQFLL	0	R	Transmit Queue Full Status Flag 0: The transmit queue is not full. 1: The transmit queue is full.
0	TXQEMP	1	R	Transmit Queue Empty Status Flag 0: The transmit queue contains messages. 1: The transmit queue contains no message (transmit queue empty).

Note 1. The only effective value for writing to this flag bit is 0, which clears the bit. Otherwise writing to the bit results in retention of its state.

TXQIF Flag

The TXQIF flag is set to 1 when the event specified by the TXQIM bit in the RSCANnTXQCCm register has occurred. The TXQIF flag is cleared to 0 in channel reset mode or by writing 0 to this flag. This flag is not cleared to 0 by setting the TXQE bit in the RSCANnTXQCCm register to 0 (the transmit queue is not used).

TXQFLL Flag

The TXQFLL flag is set to 1 when the number of messages set for the transmit queue matches the transmit queue depth set by the TXQDC[3:0] bits in the RSCANnTXQCCm register.

This flag is cleared to 0 in any of the following cases.

- The number of messages set for the transmit queue is smaller than the transmit queue depth set by the TXQDC[3:0] bits.
- In channel reset mode

TXQEMP Flag

The TXQEMP flag is cleared to 0 when even a single message is set for the transmit queue.

This flag is set to 1 in any of the following cases.

- The TXQE bit is set to 0 (the transmit queue is not used).
- The transmit queue becomes empty.
- In channel reset mode

28.3.12.3 RSCANnTXQPCTRM — Transmit Queue Pointer Control Register (m = 0, 1)

Access Size: RSCANnTXQPCTRM register can only be written in 32-bit units
 RSCANnTXQPCTRM_L, RSCANnTXQPCTRM_H registers can only be written in 16-bit units
 RSCANnTXQPCTRM_{LL}, RSCANnTXQPCTRM_{LH}, RSCANnTXQPCTRM_{HL}, RSCANnTXQPCTRM_{HH} registers can only be written in 8-bit units

Address(es): RSCANnTXQPCTRM: <RSCFDn_base> + H'03E0 + (H'04 × m)
 RSCANnTXQPCTRM_L: <RSCFDn_base> + H'03E0 + (H'04 × m),
 RSCANnTXQPCTRM_H: <RSCFDn_base> + H'03E2 + (H'04 × m)
 RSCANnTXQPCTRM_{LL}: <RSCFDn_base> + H'03E0 + (H'04 × m),
 RSCANnTXQPCTRM_{LH}: <RSCFDn_base> + H'03E1 + (H'04 × m),
 RSCANnTXQPCTRM_{HL}: <RSCFDn_base> + H'03E2 + (H'04 × m),
 RSCANnTXQPCTRM_{HH}: <RSCFDn_base> + H'03E3 + (H'04 × m)

Initial Value: H'0000 0000

Bit	31	30	29	28	27	26	25	24	23	22	21	20	19	18	17	16
	—	—	—	—	—	—	—	—	—	—	—	—	—	—	—	—
Initial Value	0	0	0	0	0	0	0	0	0	0	0	0	0	0	0	0
R/W	R	R	R	R	R	R	R	R	R	R	R	R	R	R	R	R
Bit	15	14	13	12	11	10	9	8	7	6	5	4	3	2	1	0
	—	—	—	—	—	—	—	—	TXQPC[7:0]							
Initial Value	0	0	0	0	0	0	0	0	0	0	0	0	0	0	0	0
R/W	R	R	R	R	R	R	R	R	W	W	W	W	W	W	W	W

Bit	Bit Name	Initial Value	R/W	Description
31 to 8	—	All 0	R	Reserved The write value should be the value after reset.
7 to 0	TXQPC[7:0]	All 0	W	Transmit Queue Pointer Control Writing H'FF to these bits moves the write pointer of the transmit queue to the next queue buffer.

TXQPC[7:0] Bits

Writing H'FF to the TXQPC[7:0] bits moves the write pointer to the next transmit queue buffer and generates a transmit request of the message. Write transmit messages to the RSCANnTMID_p, RSCANnTMPTR_p, RSCANnTMD_{F0_p}, and RSCANnTMD_{F1_p} registers (p = 15, 31) before writing H'FF to the TXQPC[7:0] bits.

When writing H'FF to these bits, make sure that the TXQE bit in the RSCANnTXQCC_m register is set to 1 (the transmit queue is used) and the TXQFLL flag in the RSCANnTXQSTS_m register is 0 (the transmit queue is not full).

28.3.13 Details of Transmit history-related Registers

28.3.13.1 RSCANnTHLCCm — Transmit History Configuration and Control Register (m = 0, 1)

Access Size: RSCANnTHLCCm register can be read/written in 32-bit units
 RSCANnTHLCCmL, RSCANnTHLCCmH registers can be read/written in 16-bit units
 RSCANnTHLCCmLL, RSCANnTHLCCmLH, RSCANnTHLCCmHL, RSCANnTHLCCmHH registers can be read/written in 8-bit units

Address(es): RSCANnTHLCCm: <RSCFDn_base> + H'0400 + (H'04 × m)
 RSCANnTHLCCmL: <RSCFDn_base> + H'0400 + (H'04 × m),
 RSCANnTHLCCmH: <RSCFDn_base> + H'0402 + (H'04 × m)
 RSCANnTHLCCmLL: <RSCFDn_base> + H'0400 + (H'04 × m),
 RSCANnTHLCCmLH: <RSCFDn_base> + H'0401 + (H'04 × m),
 RSCANnTHLCCmHL: <RSCFDn_base> + H'0402 + (H'04 × m),
 RSCANnTHLCCmHH: <RSCFDn_base> + H'0403 + (H'04 × m)

Initial Value: H'0000 0000

Bit	31	30	29	28	27	26	25	24	23	22	21	20	19	18	17	16
	—	—	—	—	—	—	—	—	—	—	—	—	—	—	—	—
Initial Value	0	0	0	0	0	0	0	0	0	0	0	0	0	0	0	0
R/W	R	R	R	R	R	R	R	R	R	R	R	R	R	R	R	R
Bit	15	14	13	12	11	10	9	8	7	6	5	4	3	2	1	0
	—	—	—	—	—	THLDT E	THLIM	THLIE	—	—	—	—	—	—	—	THLE
Initial Value	0	0	0	0	0	0	0	0	0	0	0	0	0	0	0	0
R/W	R	R	R	R	R	R/W	R/W	R/W	R	R	R	R	R	R	R	R/W

Bit	Bit Name	Initial Value	R/W	Description
31 to 11	—	All 0	R	Reserved These bits are read as the value after reset. The write value should be the value after reset.
10	THLDTE	0	R/W	Transmit History Target Buffer Select 0: Entry from transmit/receive FIFO buffers and transmit queue 1: Entry from transmit buffers, transmit/receive FIFO buffers, and transmit queue
9	THLIM	0	R/W	Transmit History Interrupt Source Select 0: When 12 sets of data have been stored in the transmit history buffer 1: When a single set of transmit history data has been stored
8	THLIE	0	R/W	Transmit History Interrupt Enable 0: Transmit history interrupt is disabled. 1: Transmit history interrupt is enabled.
7 to 1	—	All 0	R	Reserved These bits are read as the value after reset. The write value should be the value after reset.
0	THLE	0	R/W	Transmit History Buffer Enable 0: Transmit history buffer is not used. 1: Transmit history buffer is used.

THLDTE Bit

When this bit is set to 0, the transmit history data of messages transmitted from transmit/receive FIFO buffers and the transmit queue is stored in the transmit history buffer. When this bit is set to 1, the transmit history data of messages transmitted from transmit buffers, transmit/receive FIFO buffers, and the transmit queue is stored in the transmit history buffer.

Modify this bit only in channel reset mode.

THLIM Bit

This bit is used to select a transmit history interrupt source.

Modify this bit only in channel reset mode.

THLIE Bit

When the THLIE bit is set to 1 and the source selected by the THLIM bit has occurred, a transmit history interrupt request is generated. Modify the THLIE bit only when the THLE bit set to 0.

THLE Bit

Setting this bit to 1 makes the transmit history buffer available. When data transmission from the buffer selected by the THLDTE bit has been completed, the transmit history data of transmit messages is stored in the transmit history buffer. Modify this bit in channel communication mode or channel halt mode.

This bit is cleared to 0 in channel reset mode.

28.3.13.2 RSCANnTHLSTSm — Transmit History Status Register (m = 0, 1)

Access Size: RSCANnTHLSTSm register can be read/written in 32-bit units
 RSCANnTHLSTSmL, RSCANnTHLSTSmH registers can be read/written in 16-bit units
 RSCANnTHLSTSmLL, RSCANnTHLSTSmLH, RSCANnTHLSTSmHL, RSCANnTHLSTSmHH registers can be read/written in 8-bit units

Address(es): RSCANnTHLSTSm: <RSCFDn_base> + H'0420 + (H'04 × m)
 RSCANnTHLSTSmL: <RSCFDn_base> + H'0420 + (H'04 × m),
 RSCANnTHLSTSmH: <RSCFDn_base> + H'0422 + (H'04 × m)
 RSCANnTHLSTSmLL: <RSCFDn_base> + H'0420 + (H'04 × m),
 RSCANnTHLSTSmLH: <RSCFDn_base> + H'0421 + (H'04 × m),
 RSCANnTHLSTSmHL: <RSCFDn_base> + H'0422 + (H'04 × m),
 RSCANnTHLSTSmHH: <RSCFDn_base> + H'0423 + (H'04 × m)

Initial Value: H'0000 0001

Bit	31	30	29	28	27	26	25	24	23	22	21	20	19	18	17	16
	—	—	—	—	—	—	—	—	—	—	—	—	—	—	—	—
Initial Value	0	0	0	0	0	0	0	0	0	0	0	0	0	0	0	0
R/W	R	R	R	R	R	R	R	R	R	R	R	R	R	R	R	R
Bit	15	14	13	12	11	10	9	8	7	6	5	4	3	2	1	0
	—	—	—	THLMC[4:0]				—	—	—	—	THLIF	THLELT	THLFLL	THLEMP	
Initial Value	0	0	0	0	0	0	0	0	0	0	0	0	0	0	0	1
R/W	R	R	R	R	R	R	R	R	R	R	R	R	R/W*1	R/W*1	R	R

Bit	Bit Name	Initial Value	R/W	Description
31 to 13	—	All 0	R	Reserved These bits are read as the value after reset. The write value should be the value after reset.
12 to 8	THLMC[4:0]	All 0	R	Transmit History Buffer Unread Data Counter These bits indicate the number of unread data sets stored in the transmit history buffer.
7 to 4	—	All 0	R	Reserved These bits are read as the value after reset. The write value should be the value after reset.
3	THLIF	0	R/W*1	Transmit History Interrupt Request Flag 0: No transmit history interrupt request is present. 1: A transmit history interrupt request is present.
2	THLELT	0	R/W*1	Transmit History Buffer Overflow Flag 0: Transmit history buffer overflow has not occurred. 1: Transmit history buffer overflow has occurred.
1	THLFLL	0	R	Transmit history Buffer Full Status Flag 0: Transmit history buffer is not full. 1: Transmit history buffer is full.
0	THLEMP	1	R	Transmit History Buffer Empty Status Flag 0: Transmit history buffer contains unread data. 1: Transmit history buffer contains no unread data (buffer empty).

Note 1. The only effective value for writing to this flag bit is 0, which clears the bit. Otherwise writing to the bit results in retention of its state.

THLMC[4:0] Bits

These bits indicate the number of unread data sets stored in the transmit history buffer.

These bits are cleared to 0 in channel reset mode.

THLIF Flag

The THLIF flag is set to 1 when the interrupt source specified with the THLIM bit in the RSCANnTHLCCm register occurs.

This flag is cleared to 0 in channel reset mode or by the program writing 0 to this flag.

To clear the flags of the register to 0, the program must write 0 to the corresponding flag to be cleared.

When writing 0, using store instruction, set the bit to be set to “0” to “0”, and the bits not to be set to “0” to “1”.

THLELT Flag

The THLELT flag is set to 1 when an attempt is made to store new transmit history data while the transmit history buffer is full. In this case, the new data is discarded. This flag becomes 0 in channel reset mode or by the program writing 0 to this flag.

To clear the flags of the register to 0, the program must write 0 to the corresponding flag to be cleared.

When writing 0, using store instruction, set the bit to be set to “0” to “0”, and the bits not to be set to “0” to “1”.

THLFLL Flag

The THLFLL flag is set to 1 when 16 data sets have been stored in the transmit history buffer, and is cleared to 0 when the number of data sets stored in the transmit history buffer has decreased to less than 16. This bit is also cleared to 0 in channel reset mode or when the THLE bit in the RSCANnTHLCCm register is set to 0 (transmit history buffer is not used).

THLEMP Flag

The THLEMP flag is cleared to 0 when even a single set of transmit history data has been stored in the transmit history buffer.

This flag is set to 1 when all the data in the transmit history buffer has been read. This flag is also set to 1 in channel reset mode or when the THLE bit in the RSCANnTHLCCm register is set to 0 (transmit history buffer is not used).

NOTE

To clear THLIF or THLELT flag to 0, the program must write 0. When writing, use a store instruction to write “0” to the given flag and “1” to other flags.

28.3.13.3 RSCANnTHLPCTRm — Transmit History Pointer Control Register (m = 0, 1)

Access Size: RSCANnTHLPCTRm register can only be written in 32-bit units
 RSCANnTHLPCTRmL, RSCANnTHLPCTRmH registers can only be written in 16-bit units
 RSCANnTHLPCTRmLL, RSCANnTHLPCTRmLH, RSCANnTHLPCTRmHL, RSCANnTHLPCTRmHH registers can only be written in 8-bit units

Address(es): RSCANnTHLPCTRm: <RSCFDn_base> + H'0440 + (H'04 × m)
 RSCANnTHLPCTRmL: <RSCFDn_base> + H'0440 + (H'04 × m),
 RSCANnTHLPCTRmH: <RSCFDn_base> + H'0442 + (H'04 × m)
 RSCANnTHLPCTRmLL: <RSCFDn_base> + H'0440 + (H'04 × m),
 RSCANnTHLPCTRmLH: <RSCFDn_base> + H'0441 + (H'04 × m),
 RSCANnTHLPCTRmHL: <RSCFDn_base> + H'0442 + (H'04 × m),
 RSCANnTHLPCTRmHH: <RSCFDn_base> + H'0443 + (H'04 × m)

Initial Value: H'0000 0000

Bit	31	30	29	28	27	26	25	24	23	22	21	20	19	18	17	16
	—	—	—	—	—	—	—	—	—	—	—	—	—	—	—	—
Initial Value	0	0	0	0	0	0	0	0	0	0	0	0	0	0	0	0
R/W	R	R	R	R	R	R	R	R	R	R	R	R	R	R	R	R
Bit	15	14	13	12	11	10	9	8	7	6	5	4	3	2	1	0
	—	—	—	—	—	—	—	—	THLPC[7:0]							
Initial Value	0	0	0	0	0	0	0	0	0	0	0	0	0	0	0	0
R/W	R	R	R	R	R	R	R	R	W	W	W	W	W	W	W	W

Bit	Bit Name	Initial Value	R/W	Description
31 to 8	—	All 0	R	Reserved When writing to these bits, write the value after reset.
7 to 0	THLPC[7:0]	All 0	W	Transmit History List Pointer Control Writing H'FF to these bits moves the read pointer to the next unread data in the transmit history buffer.

THLPC[7:0] Bits

When the THLPC[7:0] bits are set to H'FF, the read pointer moves to the next data in the transmit history buffer. At this time, the THLMC[4:0] (transmit history buffer unread data counter) value in the RSCANnTHLSTSm register is decremented. Write H'FF to the THLPC[7:0] bits after reading from the RSCANnTHLACCm register.

When writing H'FF to these bits, make sure that the THLE bit in the RSCANnTHLCCm register is set to 1 (transmit history buffer is used) and the THLEMP flag in the RSCANnTHLSTSm register is 0.

28.3.13.4 RSCANnTHLACCm — Transmit History Access Register (m = 0, 1)

Access Size: RSCANnTHLACCm register can be read only in 32-bit units
 RSCANnTHLACCmL, RSCANnTHLACCmH registers can be read only in 16-bit units
 RSCANnTHLACCmLL, RSCANnTHLACCmLH, RSCANnTHLACCmHL, RSCANnTHLACCmHH registers can be read only in 8-bit units

Address(es): RSCANnTHLACCm: <RSCFDn_base> + H'1800 + (H'04 × m)
 RSCANnTHLACCmL: <RSCFDn_base> + H'1800 + (H'04 × m),
 RSCANnTHLACCmH: <RSCFDn_base> + H'1802 + (H'04 × m)
 RSCANnTHLACCmLL: <RSCFDn_base> + H'1800 + (H'04 × m),
 RSCANnTHLACCmLH: <RSCFDn_base> + H'1801 + (H'04 × m),
 RSCANnTHLACCmHL: <RSCFDn_base> + H'1802 + (H'04 × m),
 RSCANnTHLACCmHH: <RSCFDn_base> + H'1803 + (H'04 × m)

Initial Value: H'0000 0000

Bit	31	30	29	28	27	26	25	24	23	22	21	20	19	18	17	16
	TMTS[15:0]															
Initial Value	0	0	0	0	0	0	0	0	0	0	0	0	0	0	0	0
R/W	R	R	R	R	R	R	R	R	R	R	R	R	R	R	R	R
Bit	15	14	13	12	11	10	9	8	7	6	5	4	3	2	1	0
	TID[7:0]							—	BN[3:0]			BT[2:0]				
Initial Value	0	0	0	0	0	0	0	0	0	0	0	0	0	0	0	0
R/W	R	R	R	R	R	R	R	R	R	R	R	R	R	R	R	R

Bit	Bit Name	Initial Value	R/W	Description																
31 to 16	TMTS[15:0]	All 0	R	Timestamp Data The timestamp data of stored data can be read.																
15 to 8	TID[7:0]	All 0	R	Label Data The label information of stored data can be read.																
7	—	0	R	Reserved This bit is read as the value after reset.																
6 to 3	BN[3:0]	All 0	R	Buffer Number Data The buffer number of transmit source (transmit buffer, transmit/receive FIFO or transmit queue) can be read.																
2 to 0	BT[2:0]	All 0	R	Buffer Type Data <table border="0" style="margin-left: 20px;"> <tr> <td>b2</td><td>b1</td><td>b0</td><td></td> </tr> <tr> <td>0</td><td>0</td><td>1</td><td>: Transmit buffer</td> </tr> <tr> <td>0</td><td>1</td><td>0</td><td>: Transmit/receive FIFO buffer</td> </tr> <tr> <td>0</td><td>0</td><td>0</td><td>: Transmit queue</td> </tr> </table>	b2	b1	b0		0	0	1	: Transmit buffer	0	1	0	: Transmit/receive FIFO buffer	0	0	0	: Transmit queue
b2	b1	b0																		
0	0	1	: Transmit buffer																	
0	1	0	: Transmit/receive FIFO buffer																	
0	0	0	: Transmit queue																	

TMTS[15:0] Bits

When the TMTSCE bit in the RSCANnGCFG register is 1, timestamp values in transmit history data stored in the transmit history buffer are displayed. When the TMTSCE bit is 0, these bits are always read as 0.

TID[7:0] Bits

These bits indicate the label information of transmit history data stored in the transmit history buffer.

BN[3:0] Bits

These bits indicate the transmit source buffer number in the transmit history data stored in the transmit history buffer.

BT[2:0] Bits

These bits indicate the type of the transmit source buffer in the transmit history data stored in the transmit history buffer.

28.3.14 Details of Test-related Registers

28.3.14.1 RSCANnGTSTCFG — Global Test Configuration Register

Access Size: RSCANnGTSTCFG register can be read/written in 32-bit units
 RSCANnGTSTCFGL, RSCANnGTSTCFGH registers can be read/written in 16-bit units
 RSCANnGTSTCFGLL, RSCANnGTSTCFGLH, RSCANnGTSTCFGHL, RSCANnGTSTCFGHH registers can be read/written in 8-bit units

Address(es): RSCANnGTSTCFG: <RSCFDn_base> + H'0468
 RSCANnGTSTCFGL: <RSCFDn_base> + H'0468, RSCANnGTSTCFGH: <RSCFDn_base> + H'046A
 RSCANnGTSTCFGLL: <RSCFDn_base> + H'0468, RSCANnGTSTCFGLH: <RSCFDn_base> + H'0469,
 RSCANnGTSTCFGHL: <RSCFDn_base> + H'046A, RSCANnGTSTCFGHH: <RSCFDn_base> + H'046B

Initial Value: H'0000 0000

Bit	31	30	29	28	27	26	25	24	23	22	21	20	19	18	17	16
	—	—	—	—	—	—	—	—	—	RTMPS[6:0]						
Initial Value	0	0	0	0	0	0	0	0	0	0	0	0	0	0	0	0
R/W	R	R	R	R	R	R	R	R	R	R/W	R/W	R/W	R/W	R/W	R/W	R/W
Bit	15	14	13	12	11	10	9	8	7	6	5	4	3	2	1	0
	—	—	—	—	—	—	—	—	—	—	—	—	—	—	C1ICBCE	C0ICBCE
Initial Value	0	0	0	0	0	0	0	0	0	0	0	0	0	0	0	0
R/W	R	R	R	R	R	R	R	R	R	R	R/W	R/W	R/W	R/W	R/W	R/W

Bit	Bit Name	Initial Value	R/W	Description
31 to 23	—	All 0	R	Reserved These bits are read as the value after reset. The write value should be the value after reset.
22 to 16	RTMPS[6:0]	All 0	R/W	RAM Test Page Configuration Set a value within a range of page 0 (H'00) to page 19 (H'13).
15 to 2	—	All 0	R	Reserved These bits are read as the value after reset. The write value should be the value after reset.
1	C1ICBCE	0	R/W	CAN1 Inter-Channel Communication Test Enable 0: CAN1 inter-channel communication test is disabled. 1: CAN1 inter-channel communication test is enabled.
0	C0ICBCE	0	R/W	CAN0 Inter-Channel Communication Test Enable 0: CAN0 inter-channel communication test is disabled. 1: CAN0 inter-channel communication test is enabled.

Modify the RSCANnGTSTCFG register only in global test mode.

RTMPS[6:0] Bits

These bits are used to set the RAM test target page number for RAM test. Set a value in the range of H'00 to H'13, inclusive.

C1ICBCE Bit

Setting this bit to 1 enables the channel 1 inter-channel communication test.

This bit is cleared to 0 in global reset mode.

C0ICBCE Bit

Setting this bit to 1 enables the channel 0 inter-channel communication test.

This bit is cleared to 0 in global reset mode.

28.3.14.2 RSCANnGTSTCTR — Global Test Control Register

Access Size: RSCANnGTSTCTR register can be read/written in 32-bit units
 RSCANnGTSTCTRL, RSCANnGTSTCTRH registers can be read/written in 16-bit units
 RSCANnGTSTCTRLL, RSCANnGTSTCTRLH, RSCANnGTSTCTRHL, RSCANnGTSTCTRHH registers can be read/written in 8-bit units

Address(es): RSCANnGTSTCTR: <RSCFDn_base> + H'046C
 RSCANnGTSTCTRL: <RSCFDn_base> + H'046C, RSCANnGTSTCTRH: <RSCFDn_base> + H'046E
 RSCANnGTSTCTRLL: <RSCFDn_base> + H'046C, RSCANnGTSTCTRLH: <RSCFDn_base> + H'046D,
 RSCANnGTSTCTRHL: <RSCFDn_base> + H'046E, RSCANnGTSTCTRHH: <RSCFDn_base> + H'046F

Initial Value: H'0000 0000

Bit	31	30	29	28	27	26	25	24	23	22	21	20	19	18	17	16
	—	—	—	—	—	—	—	—	—	—	—	—	—	—	—	—
Initial Value	0	0	0	0	0	0	0	0	0	0	0	0	0	0	0	0
R/W	R	R	R	R	R	R	R	R	R	R	R	R	R	R	R	R
Bit	15	14	13	12	11	10	9	8	7	6	5	4	3	2	1	0
	—	—	—	—	—	—	—	—	—	—	—	—	—	RTME	—	ICBCTME
Initial Value	0	0	0	0	0	0	0	0	0	0	0	0	0	0	0	0
R/W	R	R	R	R	R	R	R	R	R	R	R	R	R	R/W	R	R/W

Bit	Bit Name	Initial Value	R/W	Description
31 to 3	—	All 0	R	Reserved These bits are read as the value after reset. The write value should be the value after reset.
2	RTME	0	R/W	RAM Test Enable 0: RAM test is disabled. 1: RAM test is enabled.
1	—	0	R	Reserved This bit is read as the value after reset. The write value should be the value after reset.
0	ICBCTME	0	R/W	Communication Test between Channels Enable 0: Communication test between channels disabled 1: Communication test between channels enabled

RTME Bit

Setting this bit to 1 enables the RAM test. Modify this bit only in global test mode.

This bit is cleared to 0 in global reset mode.

1. Set the GMDC[1:0] bits in the RSCANnGCTR register to 10b (Global test mode).
2. Set the RTME bit to 1.
3. Check that the RTME bit is set to 1.

ICBCTME Bit

When this bit is set to 1, a communication test is enabled between the channels for which the CmICBCE bit (m = 0, 1) in the RSCANnGTSTCFG register has been set to 1. Modify the ICBCTME bit only in global test mode.

This bit is cleared to 0 in global reset mode.

28.3.14.3 RSCANnGLOCKK — Global Lock Key Register

Access Size: RSCANnGLOCKK register can only be written in 32-bit units
RSCANnGLOCKKL, RSCANnGLOCKKH registers can only be written in 16-bit units

Address(es): RSCANnGLOCKK: <RSCFDn_base> + H'047C
RSCANnGLOCKKL: <RSCFDn_base> + H'047C, RSCANnGLOCKKH: <RSCFDn_base> + H'047E

Initial Value: H'0000 0000

Bit	31	30	29	28	27	26	25	24	23	22	21	20	19	18	17	16
	—	—	—	—	—	—	—	—	—	—	—	—	—	—	—	—
Initial Value	0	0	0	0	0	0	0	0	0	0	0	0	0	0	0	0
R/W	R	R	R	R	R	R	R	R	R	R	R	R	R	R	R	R
Bit	15	14	13	12	11	10	9	8	7	6	5	4	3	2	1	0
	LOCK[15:0]															
Initial Value	0	0	0	0	0	0	0	0	0	0	0	0	0	0	0	0
R/W	W*1	W*1	W*1	W*1	W*1	W*1	W*1	W*1	W*1	W*1	W*1	W*1	W*1	W*1	W*1	W*1

Bit	Bit Name	Initial Value	R/W	Description
31 to 16	—	All 0	R	Reserved When writing these bits, write the value after reset.
15 to 0	LOCK[15:0]	All 0	W*1	Lock Key These bits are key bits to release protection of test mode.

Note 1. Writing to these bits is effective only when the RS-CANFD module is in global test mode.

The RSCANnGLOCKK register releases protection of special test bits and is write only.

For the protection release data, see **Section 28.11.4.2, Procedure for Releasing the Protection.**

LOCK[15:0] Bits

Writing the protection release data to the LOCK[15:0] bits in succession enables writing 1 to the RTME bit in the RSCANnGTSTCTR register.

After the protection has been released, writing to the I/O register area (<RSCFDn_base> + H'0000 to <RSCFDn_base> + H'04FF) of the CAN (except the RAM) enables the protection again.

Reading from the I/O register area of the CAN or reading from/writing to other areas does not enable the protection.

28.3.14.4 RSCANnRPGACCr — RAM Test Page Access Register (r = 0 to 63)

Access Size: RSCANnRPGACCr register can be read/written in 32-bit units
 RSCANnRPGACCrL, RSCANnRPGACCrH registers can be read/written in 16-bit units
 RSCANnRPGACCrLL, RSCANnRPGACCrLH, RSCANnRPGACCrHL, RSCANnRPGACCrHH registers can be read/written in 8-bit units

Address(es): RSCANnRPGACCr: $\langle \text{RSCFDn_base} \rangle + \text{H}'1900 + (\text{H}'04 \times r)$
 RSCANnRPGACCrL: $\langle \text{RSCFDn_base} \rangle + \text{H}'1900 + (\text{H}'04 \times r)$,
 RSCANnRPGACCrH: $\langle \text{RSCFDn_base} \rangle + \text{H}'1902 + (\text{H}'04 \times r)$
 RSCANnRPGACCrLL: $\langle \text{RSCFDn_base} \rangle + \text{H}'1900 + (\text{H}'04 \times r)$,
 RSCANnRPGACCrLH: $\langle \text{RSCFDn_base} \rangle + \text{H}'1901 + (\text{H}'04 \times r)$,
 RSCANnRPGACCrHL: $\langle \text{RSCFDn_base} \rangle + \text{H}'1902 + (\text{H}'04 \times r)$,
 RSCANnRPGACCrHH: $\langle \text{RSCFDn_base} \rangle + \text{H}'1903 + (\text{H}'04 \times r)$

Initial Value: H'0000 0000

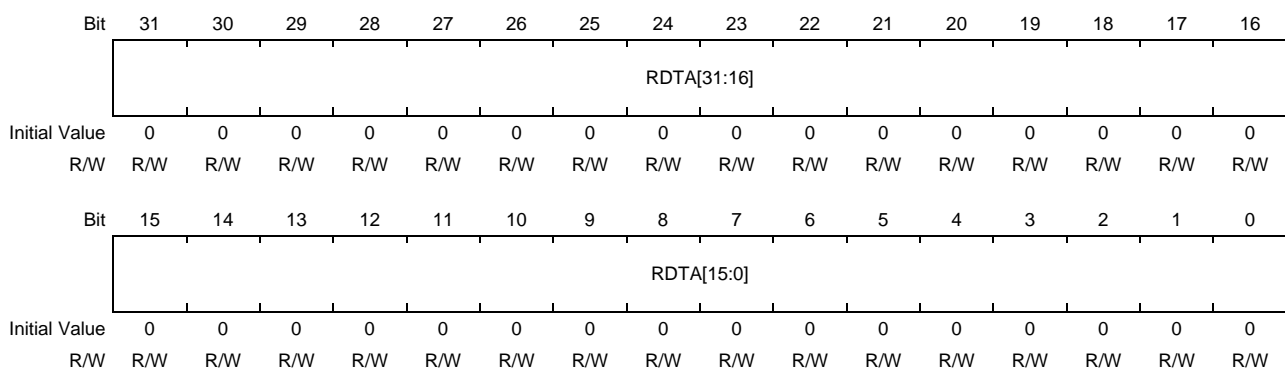

Bit	Bit Name	Initial Value	R/W	Description
31 to 0	RDTA[31:0]	All 0	R/W	RAM Data Test Access Data can be read and written in RSCAN RAM.

Modify the RSCANnRPGACCr register in global test mode with the RTME bit in the RSCANnGTSTCTR register set to 1 (RAM test is enabled).

The RSCANnRPGACCr register is readable and writable when the RTME bit is set to 1.

28.4 Registers (CANFD Mode)

This section describes all registers to be used when the RS-CANFD is used in CANFD mode.

28.4.1 List of Registers

The following tables list RS-CANFD registers to be used in CANFD mode.

For details about <RSCFDn_base>, see **Section 28.1.2, Register Base Address**.

- **Table 28.37, Registers Initialized in Global Reset Mode or Channel Reset Mode**
- **Table 28.38, Registers Initialized Only in Global Reset Mode**

Table 28.20 Registers (1/3)

Module	Register	Symbol	Address
Interface mode-related register			
RSCFDn	Global interface mode select register	RSCFDnCFDGRMCFG	<RSCFDn_base> + H'04FC
Channel-related registers			
RSCFDn	Channel m nominal bit rate configuration register	RSCFDnCFDCmNCFG	<RSCFDn_base> + H'0000 + (H'10 × m)
RSCFDn	Channel m control register	RSCFDnCFDCmCTR	<RSCFDn_base> + H'0004 + (H'10 × m)
RSCFDn	Channel m status register	RSCFDnCFDCmSTS	<RSCFDn_base> + H'0008 + (H'10 × m)
RSCFDn	Channel m error flag register	RSCFDnCFDCmERFL	<RSCFDn_base> + H'000C + (H'10 × m)
RSCFDn	Channel m data bit rate configuration register	RSCFDnCFDCmDCFG	<RSCFDn_base> + H'0500 + (H'20 × m)
RSCFDn	Channel m CANFD configuration register	RSCFDnCFDCmFDCFG	<RSCFDn_base> + H'0504 + (H'20 × m)
RSCFDn	Channel m CANFD control register	RSCFDnCFDCmFDCTR	<RSCFDn_base> + H'0508 + (H'20 × m)
RSCFDn	Channel m CANFD status register	RSCFDnCFDCmFDSTS	<RSCFDn_base> + H'050C + (H'20 × m)
RSCFDn	Channel m CANFD CRC register	RSCFDnCFDCmFDCRC	<RSCFDn_base> + H'0510 + (H'20 × m)
Global-related registers			
RSCFDn	Global configuration register	RSCFDnCFDGCFCFG	<RSCFDn_base> + H'0084
RSCFDn	Global control register	RSCFDnCFDGCCTR	<RSCFDn_base> + H'0088
RSCFDn	Global status register	RSCFDnCFDGSTS	<RSCFDn_base> + H'008C
RSCFDn	Global error flag register	RSCFDnCFDGERFL	<RSCFDn_base> + H'0090
RSCFDn	Global timestamp counter register	RSCFDnCFDGTSC	<RSCFDn_base> + H'0094
RSCFDn	Global TX Interrupt Status Register 0	RSCFDnCFDGTINTSTS0	<RSCFDn_base> + H'0460
RSCFDn	Global FD configuration register	RSCFDnCFDGFDCFG	<RSCFDn_base> + H'0474
Receive rule-related registers			
RSCFDn	Receive Rule Entry Control Register	RSCFDnCFDGAFLECTR	<RSCFDn_base> + H'0098
RSCFDn	Receive Rule Configuration Register 0	RSCFDnCFDGAFLCFG0	<RSCFDn_base> + H'009C
RSCFDn	Receive Rule ID Register j	RSCFDnCFDGAFIDj	<RSCFDn_base> + H'1000 + (H'10 × j)
RSCFDn	Receive Rule Mask Register j	RSCFDnCFDGAFMLj	<RSCFDn_base> + H'1004 + (H'10 × j)
RSCFDn	Receive Rule Pointer 0 Register j	RSCFDnCFDGAFLP0_j	<RSCFDn_base> + H'1008 + (H'10 × j)
RSCFDn	Receive Rule Pointer 1 Register j	RSCFDnCFDGAFLP1_j	<RSCFDn_base> + H'100C + (H'10 × j)

Table 28.20 Registers (2/3)

Module	Register	Symbol	Address
Receive buffer-related registers			
RSCFDn	Receive Buffer Number Register	RSCFDnCFDRMNB	<RSCFDn_base> + H'00A4
RSCFDn	Receive Buffer New Data Register y	RSCFDnCFDRMNDy	<RSCFDn_base> + H'00A8 + (H'04 × y)
RSCFDn	Receive Buffer ID Register q	RSCFDnCFDRMIDq	<RSCFDn_base> + H'2000 + (H'20 × q)
RSCFDn	Receive Buffer Pointer Register q	RSCFDnCFDRMPTRq	<RSCFDn_base> + H'2004 + (H'20 × q)
RSCFDn	Receive Buffer CANFD status register q	RSCFDnCFDRMFDSTsq	<RSCFDn_base> + H'2008 + (H'20 × q)
RSCFDn	Receive Buffer Data Field b Register q	RSCFDnCFDRMDFb_q	<RSCFDn_base> + H'200C + (H'04 × b) + (H'20 × q)
Receive FIFO buffer-related registers			
RSCFDn	Receive FIFO Buffer Configuration and Control Register x	RSCFDnCFDRFCCx	<RSCFDn_base> + H'00B8 + (H'04 × x)
RSCFDn	Receive FIFO Buffer Status Register x	RSCFDnCFDRFSTSx	<RSCFDn_base> + H'00D8 + (H'04 × x)
RSCFDn	Receive FIFO Buffer Pointer Control Register x	RSCFDnCFDRFPCTRx	<RSCFDn_base> + H'00F8 + (H'04 × x)
RSCFDn	Receive FIFO Buffer Access ID Register x	RSCFDnCFDRFIDx	<RSCFDn_base> + H'3000 + (H'80 × x)
RSCFDn	Receive FIFO Buffer Access Pointer Register x	RSCFDnCFDRFPTRx	<RSCFDn_base> + H'3004 + (H'80 × x)
RSCFDn	Receive FIFO CANFD status register x	RSCFDnCFDRFFDSTsx	<RSCFDn_base> + H'3008 + (H'80 × x)
RSCFDn	Receive FIFO Buffer Access Data Field d Register x	RSCFDnCFDRFDFd_x	<RSCFDn_base> + H'300C + (H'04 × d) + (H'80 × x)
Transmit/Receive FIFO buffer related registers			
RSCFDn	Transmit/receive FIFO Buffer Configuration and Control Register k	RSCFDnCFDCFCCKk	<RSCFDn_base> + H'0118 + (H'04 × k)
RSCFDn	Transmit/receive FIFO Buffer Status Register k	RSCFDnCFDCFSTSk	<RSCFDn_base> + H'0178 + (H'04 × k)
RSCFDn	Transmit/receive FIFO Buffer Pointer Control Register k	RSCFDnCFDCFPCTRk	<RSCFDn_base> + H'01D8 + (H'04 × k)
RSCFDn	Transmit/receive FIFO Buffer Access ID Register k	RSCFDnCFDCFIDk	<RSCFDn_base> + H'3400 + (H'80 × k)
RSCFDn	Transmit/receive FIFO Buffer Access Pointer Register k	RSCFDnCFDCFPTRk	<RSCFDn_base> + H'3404 + (H'80 × k)
RSCFDn	Transmit/receive FIFO CANFD configuration/status register k	RSCFDnCFDCFFDCSTSk	<RSCFDn_base> + H'3408 + (H'80 × k)
RSCFDn	Transmit/receive FIFO Buffer Access Data Field d Register k	RSCFDnCFDCFDFd_k	<RSCFDn_base> + H'340 + (H'04 × d) + (H'80 × k)
FIFO status-related registers			
RSCFDn	FIFO Empty Status Register	RSCFDnCFDFESTS	<RSCFDn_base> + H'0238
RSCFDn	FIFO Full Status Register	RSCFDnCFDFFFSTS	<RSCFDn_base> + H'023C
RSCFDn	FIFO Message Lost Status Register	RSCFDnCFDFMSTS	<RSCFDn_base> + H'0240
RSCFDn	Receive FIFO Buffer Interrupt Flag Status Register	RSCFDnCFDRFISTS	<RSCFDn_base> + H'0244
RSCFDn	Transmit/receive FIFO Buffer Receive Interrupt Flag Status Register	RSCFDnCFDCFRISTS	<RSCFDn_base> + H'0248
RSCFDn	Transmit/receive FIFO Buffer Transmit Interrupt Flag Status Register	RSCFDnCFDCFTISTS	<RSCFDn_base> + H'024C
FIFO DMA-related registers			
RSCFDn	DMA enable register	RSCFDnCFDCDTCT	<RSCFDn_base> + H'0490
RSCFDn	DMA status register	RSCFDnCFDCDTSTS	<RSCFDn_base> + H'0494
Transmit buffer-related registers			
RSCFDn	Transmit Buffer Control Register p	RSCFDnCFDTMCPp	<RSCFDn_base> + H'0250 + (H'01 × p)
RSCFDn	Transmit Buffer Status Register p	RSCFDnCFDTMSTSp	<RSCFDn_base> + H'02D0 + (H'01 × p)
RSCFDn	Transmit Buffer ID Register p	RSCFDnCFDTMIDp	<RSCFDn_base> + H'4000 + (H'20 × p)
RSCFDn	Transmit Buffer Pointer Register p	RSCFDnCFDTMPTRp	<RSCFDn_base> + H'4004 + (H'20 × p)
RSCFDn	Transmit Buffer CANFD configuration register p	RSCFDnCFDTMFDCTRp	<RSCFDn_base> + H'4008 + (H'20 × p)
RSCFDn	Transmit Buffer Data Field b Register p	RSCFDnCFDTMDFb_p	<RSCFDn_base> + H'400C + (H'04 × b) + (H'20 × p)
RSCFDn	Transmit Buffer Interrupt Enable Configuration Register y	RSCFDnCFDTMIECy	<RSCFDn_base> + H'0390 + (H'04 × y)

Table 28.20 Registers (3/3)

Module	Register	Symbol	Address
Transmit buffer status-related registers			
RSCFDn	Transmit Buffer Transmit Request Status Register y	RSCFDnCFDTMTRSTSy	<RSCFDn_base> + H'0350 + (H'04 × y)
RSCFDn	Transmit Buffer Transmit Abort Request Status Register y	RSCFDnCFDTMTARSTSy	<RSCFDn_base> + H'0360 + (H'04 × y)
RSCFDn	Transmit Buffer Transmit Complete Status Register y	RSCFDnCFDTMTCSTSy	<RSCFDn_base> + H'0370 + (H'04 × y)
RSCFDn	Transmit Buffer Transmit Abort Status Register y	RSCFDnCFDTMTASTSy	<RSCFDn_base> + H'0380 + (H'04 × y)
Transmit queue-related registers			
RSCFDn	Transmit Queue Configuration and Control Register m	RSCFDnCFDTXQCCm	<RSCFDn_base> + H'03A0 + (H'04 × m)
RSCFDn	Transmit Queue Status Register m	RSCFDnCFDTXQSTSm	<RSCFDn_base> + H'03C0 + (H'04 × m)
RSCFDn	Transmit Queue Pointer Control Register m	RSCFDnCFDTXQPCTm	<RSCFDn_base> + H'03E0 + (H'04 × m)
Transmit history-related registers			
RSCFDn	Transmit History Configuration and Control Register m	RSCFDnCFDTHLCCm	<RSCFDn_base> + H'0400 + (H'04 × m)
RSCFDn	Transmit History Status Register m	RSCFDnCFDTHLSTSm	<RSCFDn_base> + H'0420 + (H'04 × m)
RSCFDn	Transmit History Pointer Control Register m	RSCFDnCFDTHLPCTm	<RSCFDn_base> + H'0440 + (H'04 × m)
RSCFDn	Transmit History Access Register m	RSCFDnCFDTHLACm	<RSCFDn_base> + H'0400 + (H'04 × m)
Test-related registers			
RSCFDn	Global Test Configuration Register	RSCFDnCFDGTSTCFG	<RSCFDn_base> + H'0468
RSCFDn	Global Test Control Register	RSCFDnCFDGTSTCTR	<RSCFDn_base> + H'046C
RSCFDn	Global Lock Key Register	RSCFDnCFDGLOCKK	<RSCFDn_base> + H'047C
RSCFDn	RAM Test Page Access Register r	RSCFDnCFDRPGACCr	<RSCFDn_base> + H'6400 + (H'04 × r)

Table 28.21 Transmit Buffer p Allocated to Each Channel

	CANm
Transmit buffer p	Transmit buffer 16 × m + 0
	Transmit buffer 16 × m + 1
	Transmit buffer 16 × m + 2
	Transmit buffer 16 × m + 3
	Transmit buffer 16 × m + 4
	Transmit buffer 16 × m + 5
	Transmit buffer 16 × m + 6
	Transmit buffer 16 × m + 7
	Transmit buffer 16 × m + 8
	Transmit buffer 16 × m + 9
	Transmit buffer 16 × m + 10
	Transmit buffer 16 × m + 11
	Transmit buffer 16 × m + 12
	Transmit buffer 16 × m + 13
	Transmit buffer 16 × m + 14
	Transmit buffer 16 × m + 15

Table 28.22 Transmit/Receive FIFO Buffer k Allocated to Each Channel

	CANm
Transmit buffer k	Transmit/receive FIFO buffer 3 × m + 0
	Transmit/receive FIFO buffer 3 × m + 1
	Transmit/receive FIFO buffer 3 × m + 2

Table 28.23 Transmit Buffer p Linked to the Transmit/Receive FIFO Buffer by the Setting of Bits CFTML[3:0]

Setting of Bits CFTML[3:0]	Transmit Buffer p Linked to the Transmit/Receive FIFO Buffer
0000b	Transmit buffer $16 \times m + 0$
0001b	Transmit buffer $16 \times m + 1$
0010b	Transmit buffer $16 \times m + 2$
0011b	Transmit buffer $16 \times m + 3$
0100b	Transmit buffer $16 \times m + 4$
0101b	Transmit buffer $16 \times m + 5$
0110b	Transmit buffer $16 \times m + 6$
0111b	Transmit buffer $16 \times m + 7$
1000b	Transmit buffer $16 \times m + 8$
1001b	Transmit buffer $16 \times m + 9$
1010b	Transmit buffer $16 \times m + 10$
1011b	Transmit buffer $16 \times m + 11$
1100b	Transmit buffer $16 \times m + 12$
1101b	Transmit buffer $16 \times m + 13$
1110b	Transmit buffer $16 \times m + 14$
1111b	Transmit buffer $16 \times m + 15$

Table 28.24 Transmit Buffer p Allocated to the Transmit Queue of Each Channel

Setting of Bits TXQDC[3:0]	Transmit Buffer p Allocated to the Transmit Queue
0000b	Setting prohibited
0001b	Setting prohibited
0010b	Transmit buffer $16 \times m + 15$ to $16 \times m + 13$
0011b	Transmit buffer $16 \times m + 15$ to $16 \times m + 12$
0100b	Transmit buffer $16 \times m + 15$ to $16 \times m + 11$
0101b	Transmit buffer $16 \times m + 15$ to $16 \times m + 10$
0110b	Transmit buffer $16 \times m + 15$ to $16 \times m + 9$
0111b	Transmit buffer $16 \times m + 15$ to $16 \times m + 8$
1000b	Transmit buffer $16 \times m + 15$ to $16 \times m + 7$
1001b	Transmit buffer $16 \times m + 15$ to $16 \times m + 6$
1010b	Transmit buffer $16 \times m + 15$ to $16 \times m + 5$
1011b	Transmit buffer $16 \times m + 15$ to $16 \times m + 4$
1100b	Transmit buffer $16 \times m + 15$ to $16 \times m + 3$
1101b	Transmit buffer $16 \times m + 15$ to $16 \times m + 2$
1110b	Transmit buffer $16 \times m + 15$ to $16 \times m + 1$
1111b	Transmit buffer $16 \times m + 15$ to $16 \times m + 0$

28.4.2 Details of Interface Mode-related Registers

28.4.2.1 RSCFDnCFDGRMCFG — Global Interface Mode Select Register

Access Size: RSCFDnCFDGRMCFG register can be read/written in 32-bit units

RSCFDnCFDGRMCFG, RSCFDnCFDGRMCFGH registers can be read/written in 16-bit units

RSCFDnCFDGRMCFG, RSCFDnCFDGRMCFGH, RSCFDnCFDGRMCFGH, RSCFDnCFDGRMCFGH registers can be read/written in 8-bit units

Address(es): RSCFDnCFDGRMCFG: <RSCFDn_base> + H'04FC

RSCFDnCFDGRMCFG: <RSCFDn_base> + H'04FC, RSCFDnCFDGRMCFGH: <RSCFDn_base> + H'04FE

RSCFDnCFDGRMCFG: <RSCFDn_base> + H'04FC, RSCFDnCFDGRMCFGH: <RSCFDn_base> + H'04FD,

RSCFDnCFDGRMCFGH: <RSCFDn_base> + H'04FE, RSCFDnCFDGRMCFGH: <RSCFDn_base> + H'04FF

Initial Value: H'0000 0000

Bit	31	30	29	28	27	26	25	24	23	22	21	20	19	18	17	16
	—	—	—	—	—	—	—	—	—	—	—	—	—	—	—	—
Initial Value	0	0	0	0	0	0	0	0	0	0	0	0	0	0	0	0
R/W	R	R	R	R	R	R	R	R	R	R	R	R	R	R	R	R
Bit	15	14	13	12	11	10	9	8	7	6	5	4	3	2	1	0
	—	—	—	—	—	—	—	—	—	—	—	—	—	—	—	RCMC
Initial Value	0	0	0	0	0	0	0	0	0	0	0	0	0	0	0	0
R/W	R	R	R	R	R	R	R	R	R	R	R	R	R	R	R	R/W

Bit	Bit Name	Initial Value	R/W	Description
31 to 1	—	All 0	R	Reserved These bits are read as the value after reset. The write value should be the value after reset.
0	RCMC	0	R/W	Interface Mode Select 0: Classical CAN mode 1: CANFD mode

Note: The RSCANnGRMCFG register and the RSCFDnCFDGRMCFG register are the same register. Therefore, set either one of the registers.

Modify the RSCFDnCFDGRMCFG register only in global reset mode. Before setting other RS-CANFD registers, set this register.

RCMC Bit

Setting this bit to 0 places the RS-CANFD module in classical CAN mode. Setting this bit to 1 places the RS-CANFD module in CANFD mode. To switch classical CAN mode to CANFD mode, set the value after reset in all registers and bits allocated to the register map of classical CAN mode and then modify the RSCFDnCFDGRMCFG register.

28.4.3 Details of Channel-related Registers

28.4.3.1 RSCFDnCFDCmNCFG — Channel Nominal Bit Rate Configuration Register (m = 0, 1)

Access Size: RSCFDnCFDCmNCFG register can be read/written in 32-bit units
 RSCFDnCFDCmNCFG, RSCFDnCFDCmNCFGH registers can be read/written in 16-bit units
 RSCFDnCFDCmNCFGLL, RSCFDnCFDCmNCFGHL, RSCFDnCFDCmNCFGHL, RSCFDnCFDCmNCFGHH registers can be read/written in 8-bit units

Address(es): RSCFDnCFDCmNCFG: <RSCFDn_base> + H'0000 + (H'10 × m)
 RSCFDnCFDCmNCFG: <RSCFDn_base> + H'0000 + (H'10 × m),
 RSCFDnCFDCmNCFGH: <RSCFDn_base> + H'0002 + (H'10 × m)
 RSCFDnCFDCmNCFGLL: <RSCFDn_base> + H'0000 + (H'10 × m),
 RSCFDnCFDCmNCFGHL: <RSCFDn_base> + H'0001 + (H'10 × m),
 RSCFDnCFDCmNCFGHL: <RSCFDn_base> + H'0002 + (H'10 × m),
 RSCFDnCFDCmNCFGHH: <RSCFDn_base> + H'0003 + (H'10 × m)

Initial Value: H'0000 0000

Bit	31	30	29	28	27	26	25	24	23	22	21	20	19	18	17	16
	—	—	—	NTSEG2[4:0]				—	NTSEG1[6:0]							
Initial Value	0	0	0	0	0	0	0	0	0	0	0	0	0	0	0	0
R/W	R	R	R	R/W	R/W	R/W	R/W	R/W	R	R/W	R/W	R/W	R/W	R/W	R/W	R/W
Bit	15	14	13	12	11	10	9	8	7	6	5	4	3	2	1	0
	NSJW[4:0]				—	NBRP[9:0]										
Initial Value	0	0	0	0	0	0	0	0	0	0	0	0	0	0	0	0
R/W	R/W	R/W	R/W	R/W	R/W	R	R/W	R/W	R/W	R/W	R/W	R/W	R/W	R/W	R/W	R/W

Bit	Bit Name	Initial Value	R/W	Description
31 to 29	—	All 0	R	Reserved These bits are read as the value after reset. The write value should be the value after reset.
28 to 24	NTSEG2[4:0]	All 0	R/W	Nominal Bit Rate Time Segment 2 Control b28 b27 b26 b25 b24 0 0 0 0 0: Setting prohibited 0 0 0 0 1: 2 Tq : : 1 1 1 1 0: 31 Tq 1 1 1 1 1: 32 Tq
23	—	0	R	Reserved These bits are read as the value after reset. The write value should be the value after reset.

Bit	Bit Name	Initial Value	R/W	Description
22 to 16	NTSEG1[6:0]	All 0	R/W	Nominal Bit Rate Time Segment 1 Control b22 b21 b20 b19 b18 b17 b16 0 0 0 0 0 0 0: Setting prohibited 0 0 0 0 0 0 1: Setting prohibited 0 0 0 0 0 1 0: Setting prohibited 0 0 0 0 0 1 1: 4 Tq : : 1 1 1 1 1 1 0: 127 Tq 1 1 1 1 1 1 1: 128 Tq
15 to 11	NSJW[4:0]	All 0	R/W	Nominal Bit Rate Resynchronization Jump Width Control b15 b14 b13 b12 b11 0 0 0 0 0: 1 Tq 0 0 0 0 1: 2 Tq 0 0 0 1 0: 3 Tq : : 1 1 1 1 0: 31 Tq 1 1 1 1 1: 32 Tq
10	—	0	R	Reserved These bits are read as the value after reset. The write value should be the value after reset.
9 to 0	NBRP[9:0]	All 0	R/W	Nominal Bit Rate Prescaler Division Ratio Setting When the set value = P (0 to 1023), the nominal bit rate prescaler divides fCAN by (P + 1).

Modify the RSCFDnCFDCmNCFG register in channel reset mode or channel halt mode. Set this register in channel reset mode, and then transition to channel communication mode or channel halt mode. For the description and settings of bit timing parameters, see **Section 28.11.1, Initial Settings**.

NTSEG2[4:0] Bits

These bits are used to specify a Tq value for the length of phase segment 2 (PHASE_SEG2) of nominal bit rate. Allowed values are 2 Tq to 32 Tq, inclusive.

Set a value smaller than the value of the NTSEG1[6:0] bits.

NTSEG1[6:0] Bits

These bits specify the total length of propagation segment (PROP_SEG) and phase segment 1 (PHASE_SEG1) of nominal bit rate as a Tq value.

A value of 4 to 128 Tq is settable.

NSJW[4:0] Bits

These bits specify the resynchronization jump width of nominal bit rate as a Tq value. A value of 1 to 32 Tq is settable. Specify a value equal to or smaller than the NTSEG2[4:0] value.

NBRP[9:0] Bits

The clock obtained by dividing the CAN clock (fCAN) by the nominal bit rate prescaler ((NBRP[9:0]) + 1) becomes CANmTq(N) clock (fCANTQ(N)m). One clock of the CANmTq(N) clock becomes one Time Quantum (Tq).

28.4.3.2 RSCFDnCFDCmCTR — Channel Control Register (m = 0, 1)

Access Size: RSCFDnCFDCmCTR register can be read/written in 32-bit units
 RSCFDnCFDCmCTRL, RSCFDnCFDCmCTRH registers can be read/written in 16-bit units
 RSCFDnCFDCmCTRLL, RSCFDnCFDCmCTRHL, RSCFDnCFDCmCTRHL, RSCFDnCFDCmCTRHH registers can be read/written in 8-bit units

Address(es): RSCFDnCFDCmCTR: <RSCFDn_base> + H'0004 + (H'10 × m)
 RSCFDnCFDCmCTRL: <RSCFDn_base> + H'0004 + (H'10 × m),
 RSCFDnCFDCmCTRH: <RSCFDn_base> + H'0006 + (H'10 × m)
 RSCFDnCFDCmCTRLL: <RSCFDn_base> + H'0004 + (H'10 × m),
 RSCFDnCFDCmCTRHL: <RSCFDn_base> + H'0005 + (H'10 × m),
 RSCFDnCFDCmCTRHL: <RSCFDn_base> + H'0006 + (H'10 × m),
 RSCFDnCFDCmCTRHH: <RSCFDn_base> + H'0007 + (H'10 × m)

Initial Value: H'0000 0005

Bit	31	30	29	28	27	26	25	24	23	22	21	20	19	18	17	16
	ROM	CRCT	—	—	—	CTMS[1:0]		CTME	ERRD	BOM[1:0]		—	TDCVFI E	SOCOI E	EOCO E	TAIE
Initial Value	0	0	0	0	0	0	0	0	0	0	0	0	0	0	0	0
	R/W	R/W	R/W	R	R	R	R/W	R/W	R/W	R/W	R/W	R	R/W	R/W	R/W	R/W
Bit	15	14	13	12	11	10	9	8	7	6	5	4	3	2	1	0
	ALIE	BLIE	OLIE	BORIE	BOEIE	EPIE	EWIE	BEIE	—	—	—	—	RTBO	CSLPR	CHMDC[1:0]	
Initial Value	0	0	0	0	0	0	0	0	0	0	0	0	0	1	0	1
	R/W	R/W	R/W	R/W	R/W	R/W	R/W	R/W	R	R	R	R	R/W	R/W	R/W	R/W

Bit	Bit Name	Initial Value	R/W	Description
31	ROM	0	R/W	Restricted Operation Mode Enable 0: Restricted operation mode is disabled. 1: Restricted operation mode is enabled.
30	CRCT	0	R/W	CRC Error Test Enable 0: The first bit of the reception ID field is not inverted. 1: The first bit of the reception ID field is inverted.
29 to 27	—	All 0	R	Reserved These bits are read as the value after reset. The write value should be the value after reset.
26, 25	CTMS[1:0]	All 0	R/W	Communication Test Mode Select b26 b25 0 0: Standard test mode 0 1: Listen-only mode 1 0: Self-test mode 0 (external loopback mode) 1 1: Self-test mode 1 (internal loopback mode)
24	CTME	0	R/W	Communication Test Mode Enable 0: Communication test mode is disabled. 1: Communication test mode is enabled.
23	ERRD	0	R/W	Error Display Mode Select 0: Error flags are displayed only for the first error information after bits 14 to 8 in the RSCFDnCFDCmERFL register are all cleared. 1: Error flags for all error information are displayed.

Bit	Bit Name	Initial Value	R/W	Description
22, 21	BOM[1:0]	All 0	R/W	Bus Off Recovery Mode Select b22 b21 0 0: ISO11898-1 compliant 0 1: Entry to channel halt mode automatically at bus-off entry 1 0: Entry to channel halt mode automatically at bus-off end 1 1: Entry to channel halt mode (in bus-off state) by program request
20	—	0	R	Reserved These bits are read as the value after reset. The write value should be the value after reset.
19	TDCVFIE	0	R/W	Transmitter Delay Compensation Violation Interrupt Enable 0: A transmitter delay compensation violation interrupt is disabled. 1: A transmitter delay compensation violation interrupt is enabled.
18	SOCOIE	0	R/W	Successful Occurrence Counter Overflow Interrupt Enable 0: A successful occurrence counter overflow interrupt is disabled. 1: A successful occurrence counter overflow interrupt is enabled.
17	EOCOIE	0	R/W	Error Occurrence Counter Overflow Interrupt Enable 0: An error occurrence counter overflow interrupt is disabled. 1: An error occurrence counter overflow interrupt is enabled.
16	TAIE	0	R/W	Transmit Abort Interrupt Enable 0: Transmit abort interrupt is disabled. 1: Transmit abort interrupt is enabled.
15	ALIE	0	R/W	Arbitration Lost Interrupt Enable 0: Arbitration lost interrupt is disabled. 1: Arbitration lost interrupt is enabled.
14	BLIE	0	R/W	Bus Lock Interrupt Enable 0: Bus lock interrupt is disabled. 1: Bus lock interrupt is enabled.
13	OLIE	0	R/W	Overload Frame Transmit Interrupt Enable 0: Overload frame transmit interrupt is disabled. 1: Overload frame transmit interrupt is enabled.
12	BORIE	0	R/W	Bus Off Recovery Interrupt Enable 0: Bus off recovery interrupt is disabled. 1: Bus off recovery interrupt is enabled.
11	BOEIE	0	R/W	Bus Off Entry Interrupt Enable 0: Bus off entry interrupt is disabled. 1: Bus off entry interrupt is enabled.
10	EPIE	0	R/W	Error Passive Interrupt Enable 0: Error passive interrupt is disabled. 1: Error passive interrupt is enabled.
9	EWIE	0	R/W	Error Warning Interrupt Enable 0: Error warning interrupt is disabled. 1: Error warning interrupt is enabled.
8	BEIE	0	R/W	Bus Error Interrupt Enable 0: Bus error interrupt is disabled. 1: Bus error interrupt is enabled.
7 to 4	—	All 0	R	Reserved These bits are read as the value after reset. The write value should be the value after reset.
3	RTBO	0	R/W	Forcible Return from Bus-off When this bit is set to 1, forcible return from the bus off state is made. This bit is always read as 0.

Bit	Bit Name	Initial Value	R/W	Description
2	CSLPR	1	R/W	Channel Stop Mode 0: Other than channel stop mode 1: Channel stop mode
1, 0	CHMDC[1:0]	01b	R/W	Mode Select b1 b0 0 0: Channel communication mode 0 1: Channel reset mode 1 0: Channel halt mode 1 1: Setting prohibited

ROM Bit

When the ROM bit and the CTME bit in the RSCFDnCFDCmCTR register are set to 1, restricted operation mode is enabled. Use the restricted operation mode only when the CTMS[1:0] value in the RSCFDnCFDCmCTR register is 00b (standard test mode). Modify this bit only in channel halt mode. This bit is always 0 in channel reset mode.

CRCT Bit

This bit is used to test the CRC generation circuit in the RS-CANFD module. Setting this bit to 1 inverts the first bit of the ID field when a message is received. With this inversion of bit, the CRC calculation result does not match the normal CRC value of the received frame, which can detect a CRC error (the CERR bit in the RSCFDnCFDCmERFL register is 1). When using this function, note the following.

- This function is available while the CTME bit in the RSCFDnCFDCmCTR register is 1 (communication test mode enabled).
- This function cannot communicate with other CAN nodes. Use this function for inter-channel communication test (the CmICBCE bit in the RSCFDnCFDGTSTCFG register is 1).
- Bit inversion in the ID field may cause bit stuffing rule violation. In that case, no CRC error is detected but a stuff error is detected.

Modify this bit only in channel halt mode. This bit is always 0 in channel reset mode.

CTMS[1:0] Bits

These bits are used to select a communication test mode. Modify these bits in channel halt mode only. These bits are set to 0 in channel reset mode.

CTME Bit

Setting this bit to 1 enables communication test mode. Modify these bits in channel halt mode. This bit is set to 0 in channel reset mode.

ERRD Bit

This bit is used to control the display mode of bits 14 to 8 in the RSCFDnCFDCmERFL register.

When this bit is clear to 0, if any error is detected while the flags of bits 14-8 in the RSCFDnCFDCmERFL register are all 0, only the flags of the first error event are set to 1. If two or more errors occur in the first error event, all the flags of the detected errors are set to 1.

When this bit is set to 1, all the flags of errors that have occurred are set to 1 regardless of the error occurrence order. Modify this bit only in channel reset mode or channel halt mode.

BOM[1:0] Bits

These bits are used to select the bus off recovery mode of the RS-CANFD module.

When the BOM[1:0] bits are set to 00b, return from the bus off state to the error active state is compliant with the CAN specifications. That is, the RS-CANFD module reenters the CAN communication (error active state) after 11 consecutive recessive bits are detected 128 times. A bus off recovery interrupt request is generated at the time of return from the bus off state. Even if the CHMDC[1:0] bits are set to 10b (channel halt mode) before recessive bits are detected 128 times, the RS-CANFD module does not transition to channel halt mode until recessive bits are detected 128 times.

When the RS-CANFD module reaches the bus off state when the BOM[1:0] bits are set to 01b, the CHMDC[1:0] bits in the RSCFDnCFDCmCTR register ($m = 0, 1$) are set to 10b and the RS-CANFD module transitions to channel halt mode. No bus off recovery interrupt request is generated and the TEC[7:0] and REC[7:0] bits in the RSCFDnCFDCmSTS register are cleared to H'00.

When the RS-CANFD module reaches the bus off state when the BOM[1:0] bits are set to 10b, the CHMDC[1:0] bits are set to 10b and the RS-CANFD module transitions to channel halt mode after return from the bus off state (11 consecutive recessive bits are detected 128 times). A bus off recovery interrupt request is generated at the time of return from the bus off state and the TEC[7:0] and REC[7:0] bits are cleared to H'00.

When the BOM[1:0] bits are set to 11b and the CHMDC[1:0] bits are set to 10b while the RS-CANFD module is in the bus off state, the RS-CANFD module transitions to channel halt mode. No bus off recovery interrupt request is generated at the time of return from the bus off state and the TEC[7:0] and REC[7:0] bits are cleared to H'00. However, if 11 consecutive recessive bits are detected 128 times and the RS-CANFD module has recovered to the error active state from the bus off state before the CHMDC[1:0] bits are set to 10b, a bus off recovery interrupt request is generated.

If a program writes to the CHMDC[1:0] bit at the same time as the RS-CANFD module transition to channel halt mode (at bus off entry when the BOM[1:0] bits are 01b or at bus off end when the BOM[1:0] bits are 10b), the program's writing takes precedence. Modify the BOM[1:0] bits only in channel reset mode.

TDCVFIE Bit

When the TDCVF flag in the RSCFDnCFDCmFDSTS register is set to 1 after the TDCVFIE bit is set to 1, an interrupt request occurs. Modify this bit only in channel reset mode.

SOCOIE Bit

When the SOCO flag in the RSCFDnCFDCmFDSTS register is set to 1 after the SOCOIE bit is set to 1, an interrupt request occurs. Modify this bit only in channel reset mode.

EOCOIE Bit

When the EOCO flag in the RSCFDnCFDCmFDSTS register is set to 1 after the EOCOIE bit is set to 1, an interrupt request occurs. Modify this bit only in channel reset mode.

TAIE Bit

When transmit abort of the transmit buffer is completed with the TAIE bit set to 1, an interrupt request is generated. Modify this bit only in channel reset mode.

ALIE Bit

When the ALF flag in the RSCFDnCFDCmERFL register is set to 1 with the ALIE bit set to 1, an error interrupt request is generated. Modify this bit only in channel reset mode.

BLIE Bit

When the BLF flag in the RSCFDnCFDCmERFL register is set to 1 with the BLIE bit set to 1, an error interrupt request is generated. Modify this bit only in channel reset mode.

OLIE Bit

When the OVLF flag in the RSCFDnCFDCmERFL register is set to 1 with the OLIE bit set to 1, an error interrupt request is generated. Modify this bit only in channel reset mode.

BORIE Bit

When the BORF flag in the RSCFDnCFDCmERFL register is set to 1 with the BORIE bit set to 1, an error interrupt request is generated. Modify this bit only in channel reset mode.

BOEIE Bit

When the BOEF flag in the RSCFDnCFDCmERFL register is set to 1 with the BOEIE bit set to 1, an error interrupt request is generated. Modify this bit only in channel reset mode.

EPIE Bit

When the EPF flag in the RSCFDnCFDCmERFL register is set to 1 with the EPIE bit set to 1, an error interrupt request is generated. Modify this bit only in channel reset mode.

EWIE Bit

When the EWF flag in the RSCFDnCFDCmERFL register is set to 1 with the EWIE bit set to 1, an error interrupt request is generated. Modify this bit only in channel reset mode.

BEIE Bit

When the BEF flag in the RSCFDnCFDCmERFL register is set to 1 with the BEIE bit set to 1, an error interrupt request is generated. Modify this bit only in channel reset mode.

RTBO Bit

Setting this bit to 1 in the bus off state forcibly returns the state from the bus off state to the error active state. This bit is automatically cleared to 0. Setting this bit to 1 clears the TEC[7:0] and REC[7:0] bits in the RSCFDnCFDCmSTS register to H'00 and also clears the BOSTS flag in the RSCFDnCFDCmSTS register to 0 (not in bus off state). The other registers remain unchanged. No bus off recovery interrupt request is generated upon return from the bus off state in this case. Use this bit only when the BOM[1:0] bits in the RSCFDnCFDCmCTR register are 00b (ISO11898-1 compliant).

A delay of up to 1 CAN bit time occurs after the RTBO bit is set to 1 until the RSCAN module transitions to the error active state. Set this bit to 1 in channel communication mode.

CSLPR Bit

Setting this bit to 1 places the channel into channel stop mode.

Clearing this bit to 0 makes the channel exit channel stop mode.

This bit should not be modified in channel communication mode or channel halt mode.

CHMDC[1:0] Bits

These bits are used to select a channel mode (channel communication mode, channel reset mode, or channel halt mode). For details, see **Figure 28.5**. Setting the CSLPR bit to 1 in channel reset mode allows transition to channel stop mode.

Do not set the CHMDC[1:0] bits to 11b. When the CAN module has automatically transitioned to channel halt mode based on the setting of the BOM[1:0] bits, the CHMDC[1:0] bits automatically become 10b.

28.4.3.3 RSCFDnCFDCmSTS — Channel Status Register (m = 0, 1)

Access Size: RSCFDnCFDCmSTS register can be read/written in 32-bit units
 RSCFDnCFDCmSTSL, RSCFDnCFDCmSTSH registers can be read/written in 16-bit units
 RSCFDnCFDCmSTSLL, RSCFDnCFDCmSTSLH, RSCFDnCFDCmSTSHL, RSCFDnCFDCmSTSHH registers can be read/written in 8-bit units

Address(es): RSCFDnCFDCmSTS: <RSCFDn_base> + H'0008 + (H'10 × m)
 RSCFDnCFDCmSTSL: <RSCFDn_base> + H'0008 + (H'10 × m),
 RSCFDnCFDCmSTSH: <RSCFDn_base> + H'000A + (H'10 × m)
 RSCFDnCFDCmSTSLL: <RSCFDn_base> + H'0008 + (H'10 × m),
 RSCFDnCFDCmSTSLH: <RSCFDn_base> + H'0009 + (H'10 × m),
 RSCFDnCFDCmSTSHL: <RSCFDn_base> + H'000A + (H'10 × m),
 RSCFDnCFDCmSTSHH: <RSCFDn_base> + H'000B + (H'10 × m)

Initial Value: H'0000 0005

Bit	31	30	29	28	27	26	25	24	23	22	21	20	19	18	17	16
	TEC[7:0]								REC[7:0]							
Initial Value	0	0	0	0	0	0	0	0	0	0	0	0	0	0	0	0
R/W	R	R	R	R	R	R	R	R	R	R	R	R	R	R	R	R
Bit	15	14	13	12	11	10	9	8	7	6	5	4	3	2	1	0
	—	—	—	—	—	—	—	ESIF	COMSTS	RECSTS	TRMSTS	BOSTS	EPSTS	CSLPTS	CHLPTS	CRSTS
Initial Value	0	0	0	0	0	0	0	0	0	0	0	0	0	1	0	1
R/W	R	R	R	R	R	R	R	R/W*1	R	R	R	R	R	R	R	R

Bit	Bit Name	Initial Value	R/W	Description
31 to 24	TEC[7:0]	All 0	R	The transmit error counter (TEC) can be read.
23 to 16	REC[7:0]	All 0	R	The receive error counter (REC) can be read.
15 to 9	—	All 0	R	Reserved These bits are read as the value after reset. The write value should be the value after reset.
8	ESIF	0	R/W*1	Error State Indication Flag 0: No CANFD message whose ESI bit is recessive has been received. 1: At least one CANFD message whose ESI bit is recessive has been received.
7	COMSTS	0	R	Communication Status Flag 0: Communication is not ready. 1: Communication is ready.
6	RECSTS	0	R	Receive Status Flag 0: Bus idle, in transmission or bus off state 1: In reception
5	TRMSTS	0	R	Transmit Status Flag 0: Bus idle or in reception 1: In transmission or bus off state
4	BOSTS	0	R	Bus Off Status Flag 0: Not in bus off state 1: In bus off state
3	EPSTS	0	R	Error Passive Status Flag 0: Not in error passive state 1: In error passive state

Bit	Bit Name	Initial Value	R/W	Description
2	CSLPSTS	1	R	Channel Stop Status Flag 0: Not in channel stop mode 1: In channel stop mode
1	CHLTSTS	0	R	Channel Halt Status Flag 0: Not in channel halt mode 1: In channel halt mode
0	CRSTSTS	1	R	Channel Reset Status Flag 0: Not in channel reset mode 1: In channel reset mode

Note 1. The only effective value for writing to this flag bit is 0, which clears the bit. Otherwise writing to the bit results in retention of its state.

TEC[7:0] Bits

These bits contain the transmit error counter value. For transmit error counter increment/decrement conditions, see the CAN specification (ISO11898-1).

These bits are cleared to 0 in channel reset mode.

REC[7:0] Bits

These bits contain the receive error counter value. For receive error counter increment/decrement conditions, see the CAN specifications (ISO11898-1).

These bits are cleared to 0 in channel reset mode.

ESIF Flag

When the recessive ESI bit is detected in a successfully received message, this flag is set to 1. In loopback mode or mirror mode, the own transmission message is regarded as a received message. To clear this flag to 0, write 0 to this bit by the program. This bit cannot be set to 1 by the program. If the flag setting (to 1) timing matches the writing 0 (by the program) timing, this flag is set to 1.

This flag is 0 in channel reset mode.

COMSTS Flag

This bit indicates that communication is ready.

This flag becomes 1 when the CAN module has detected 11 consecutive recessive bits after it has transitioned from channel reset mode or channel halt mode to channel communication mode. This flag is cleared to 0 in channel reset mode or channel halt mode.

RECSTS Flag

This flag is set to 1 when reception has started, and is cleared to 0 when the bus has become idle or transmission has started.

TRMSTS Flag

This flag is set to 1 when transmission has started, and is cleared to 0 when the bus has become idle or reception has started. This flag remains 1 in the bus off state.

BOSTS Flag

This flag is set to 1 when the bus off state ($TEC[7:0] > 255$) is entered. It is cleared to 0 when the CAN module has exited the bus off state.

EPSTS Flag

This flag is set to 1 when the RS-CANFD module has entered the error passive state ($(128 \leq TEC[7:0] \leq 255)$ or $(128 \leq REC[7:0])$), It is cleared to 0 when the RS-CANFD module has exited the error passive state or has entered channel reset mode.

CSLPSTS Flag

This flag is set to 1 when the CAN module has transitioned to channel stop mode, and is cleared to 0 when the CAN module has returned from channel stop mode.

CHLTSTS Flag

This flag is set to 1 when the CAN module has transitioned to channel halt mode, and is cleared to 0 when the CAN module has returned from channel halt mode.

CRSTSTS Flag

This flag is set to 1 when the CAN module has transitioned to channel reset mode, and is cleared to 0 when the CAN module has transitioned to channel communication mode or channel halt mode. This flag remains 1 when the CAN module transitions from channel reset mode to channel stop mode.

28.4.3.4 RSCFDnCFDCmERFL — Channel Error Flag Register (m = 0, 1)

Access Size: RSCFDnCFDCmERFL register can be read/written in 32-bit units
 RSCFDnCFDCmERFLL, RSCFDnCFDCmERFLH registers can be read/written in 16-bit units
 RSCFDnCFDCmERFLLL, RSCFDnCFDCmERFLLH, RSCFDnCFDCmERFLHL, RSCFDnCFDCmERFLHH registers can be read/written in 8-bit units

Address(es): RSCFDnCFDCmERFL: <RSCFDn_base> + H'000C + (H'10 × m)
 RSCFDnCFDCmERFLL: <RSCFDn_base> + H'000C + (H'10 × m),
 RSCFDnCFDCmERFLH: <RSCFDn_base> + H'000E + (H'10 × m)
 RSCFDnCFDCmERFLLL: <RSCFDn_base> + H'000C + (H'10 × m),
 RSCFDnCFDCmERFLLH: <RSCFDn_base> + H'000D + (H'10 × m),
 RSCFDnCFDCmERFLHL: <RSCFDn_base> + H'000E + (H'10 × m),
 RSCFDnCFDCmERFLHH: <RSCFDn_base> + H'000F + (H'10 × m)

Initial Value: H'0000 0000

Bit	31	30	29	28	27	26	25	24	23	22	21	20	19	18	17	16
	—	CRCREG[14:0]														
Initial Value	0	0	0	0	0	0	0	0	0	0	0	0	0	0	0	0
R/W	R	R	R	R	R	R	R	R	R	R	R	R	R	R	R	R
Bit	15	14	13	12	11	10	9	8	7	6	5	4	3	2	1	0
	—	ADERR	B0ERR	B1ERR	CERR	AERR	FERR	SERR	ALF	BLF	OVLf	BORF	BOEF	EPF	EWf	BEF
Initial Value	0	0	0	0	0	0	0	0	0	0	0	0	0	0	0	0
R/W	R	R/W*1	R/W*1	R/W*1	R/W*1	R/W*1	R/W*1	R/W*1	R/W*1	R/W*1	R/W*1	R/W*1	R/W*1	R/W*1	R/W*1	R/W*1

Bit	Bit Name	Initial Value	R/W	Description
31	—	0	R	Reserved This bit is read as the value after reset. The write value should be the value after reset.
30 to 16	CRCREG [14:0]	All 0	R	CRC Calculation Data (CRC length:15 bits) A CRC value calculated based on the transmit message or receive message is indicated.
15	—	0	R	Reserved This bit is read as the value after reset. The write value should be the value after reset.
14	ADERR	0	R/W*1	ACK Delimiter Error Flag 0: No ACK delimiter error is detected. 1: ACK delimiter error is detected.
13	B0ERR	0	R/W*1	Dominant Bit Error Flag 0: No dominant bit error is detected. 1: Dominant bit error is detected.
12	B1ERR	0	R/W*1	Recessive Bit Error Flag 0: No recessive bit error is detected. 1: Recessive bit error is detected.
11	CERR	0	R/W*1	CRC Error Flag 0: No CRC error is detected. 1: CRC error is detected.
10	AERR	0	R/W*1	ACK Error Flag 0: No ACK error is detected. 1: ACK error is detected.

Bit	Bit Name	Initial Value	R/W	Description
9	FERR	0	R/W*1	Form Error Flag 0: No form error is detected. 1: Form error is detected.
8	SERR	0	R/W*1	Stuff Error Flag 0: No stuff error is detected. 1: Stuff error is detected.
7	ALF	0	R/W*1	Arbitration-lost Flag 0: No arbitration-lost is detected. 1: Arbitration-lost is detected.
6	BLF	0	R/W*1	Bus Lock Flag 0: No channel bus is detected. 1: Channel bus is detected.
5	OVLf	0	R/W*1	Overload Flag 0: No overload is detected. 1: Overload is detected.
4	BORF	0	R/W*1	Bus Off Recovery Flag 0: No bus off recovery is detected. 1: Bus off recovery is detected.
3	BOEF	0	R/W*1	Bus Off Entry Flag 0: No bus off entry is detected. 1: Bus off entry is detected.
2	EPF	0	R/W*1	Error Passive Flag 0: No error passive is detected. 1: Error passive is detected.
1	EWf	0	R/W*1	Error Warning Flag 0: No error warning is detected. 1: Error warning is detected.
0	BEF	0	R/W*1	Bus Error Flag 0: No channel bus error is detected. 1: Channel bus error is detected.

Note 1. The only effective value for writing to this flag bit is 0, which clears the bit. Otherwise writing to the bit results in retention of its state.

See the CAN specification (ISO11898-1) for a description of error occurrence conditions. To clear each flag of this register, the program must write a 0 to the corresponding bit. These flags cannot be set to 1 by the program. If any of these flags is set to 0 at the same time that the program writes 0 to the flag, the flag is still set to 1. The channel reset mode transition clears all of these flags to 0.

If the ERRD bit in the RSCFDnCFDCmCTR register is set to 0 (i.e., only the flags for the first error event are displayed) and an error related to bits 14 to 8 of RSCFDnCFDCmERFL is detected, the flag bits are only set by the error event if bits 14 to 8 were all 0 at the when time the error occurred.

CRCREG[14:0] Flag

When the CTME bit in the RSCFDnCFDCmCTR register is set to 1 (communication test mode is enabled), if transmit or receive message is a classical CAN frame (CRC length = 15 bits), this flag is updated and the CRC value calculated based on the message can be read. When a CANFD frame is sent or received, the value of CRCREG[20:0] bits in the RSCFDnCFDCmFDCRC register is updated. When the CTME bit is set to 0 (communication test mode is disabled), these bits are always read as 0.

ADERR Flag

This flag is set to 1 when a form error has been detected in the ACK delimiter during transmission.

B0ERR Flag

This flag is set to 1 when a recessive bit has been detected though a dominant bit was transmitted.

B1ERR Flag

This flag is set to 1 when a dominant bit has been detected though a recessive bit was transmitted.

CERR Flag

This flag is set to 1 when a CRC error has been detected.

AERR Flag

This flag is set to 1 when an ACK error has been detected.

FERR Flag

This flag is set to 1 when a form error has been detected.

SERR Flag

This flag is set to 1 when a stuff error has been detected.

ALF Flag

This flag is set to 1 when an arbitration-lost has been detected.

BLF Flag

This flag is set to 1 when 32 consecutive dominant bits have been detected on the CAN bus in channel communication mode. After that, detection of a dominant lock is restarted when either of the following conditions is met.

- A recessive bit is detected after the BLF bit has been cleared from 1 to 0.
- The CAN module transitions to channel reset mode and returns to channel communication mode after the BLF bit has been cleared from 1 to 0.

OVLFFlag

This flag is set to 1 when the overload frame transmit condition has been detected when performing reception or transmission.

BORF Flag

This flag is set to 1 when 11 consecutive recessive bits have been detected 128 times and the CAN module returns from the bus off state. However, this flag is not set to 1 if the CAN module returns from the bus off state in any of the following ways before 11 consecutive recessive bits are detected 128 times.

- The CHMDC[1:0] bits in the RSCFDnCFDCmCTR register are set to 01b (channel reset mode).
- The RTBO bit in the RSCFDnCFDCmCTR register is set to 1 (forcible return from the bus off state is made).
- The BOM[1:0] bits in the RSCFDnCFDCmCTR register are set to 01b (transition to channel halt mode at bus off entry).
- The CHMDC[1:0] bits in the RSCFDnCFDCmCTR register are set to 10b (channel halt mode) before 11 consecutive recessive bits are detected 128 times with the BOM[1:0] bits set to 11b (transition to channel halt mode upon a request from the program during bus off).

BOEF Flag

This flag is set to 1 when the bus off state is reached (TEC[7:0] value > 255). This flag is also set to 1 if the bus off state is reached when the BOM[1:0] bits in the RSCFDnCFDCmCTR register (m = 0, 1) set to 01b (transition to channel halt mode at bus off entry).

EPF Flag

This flag becomes 1 when the error passive state is reached (REC[7:0] or TEC[7:0] value > 127).

This flag becomes 1 only when the REC[7:0] or TEC[7:0] value first exceeds 127. Therefore, if the program writes 0 to this flag while the value of REC[7:0] or TEC[7:0] remains over 127, this bit is not set to 1 until both REC [7:0] and TEC[7:0] values become 127 or less and then the REC[7:0] or TEC[7:0] value exceeds 127 again.

EWF Flag

This flag is set to 1 only when the REC[7:0] or TEC[7:0] value first exceeds 95. Therefore, if the program writes 0 to this flag while the value of REC[7:0] or TEC[7:0] remains over 95, this bit is not set to 1 until both REC [7:0] and TEC[7:0] values become 95 or less and then the REC[7:0] or TEC[7:0] value exceeds 95 again.

BEF Flag

This flag is set to 1 when any one of the ADERR, BOERR, B1ERR, CERR, AERR, FERR, and SERR flags in the RSCFDnCFDCmERFL register is set to 1.

NOTE

To clear the flag of this register to 0, use a store instruction to write "0" to the given flag and "1" to the other flags.

28.4.3.5 RSCFDnCFDCmDCFG — Channel Data Bit Rate Configuration Register (m = 0, 1)

Access Size: RSCFDnCFDCmDCFG register can be read/written in 32-bit units
 RSCFDnCFDCmDCFGL, RSCFDnCFDCmDCFGLH registers can be read/written in 16-bit units
 RSCFDnCFDCmDCFGLL, RSCFDnCFDCmDCFGLH, RSCFDnCFDCmDCFGLH, RSCFDnCFDCmDCFGLH registers can be read/written in 8-bit units

Address(es): RSCFDnCFDCmDCFG: <RSCFDn_base> + H'0500 + (H'20 × m)
 RSCFDnCFDCmDCFGL: <RSCFDn_base> + H'0500 + (H'20 × m),
 RSCFDnCFDCmDCFGLH: <RSCFDn_base> + H'0502 + (H'20 × m)
 RSCFDnCFDCmDCFGLL: <RSCFDn_base> + H'0500 + (H'20 × m),
 RSCFDnCFDCmDCFGLH: <RSCFDn_base> + H'0501 + (H'20 × m),
 RSCFDnCFDCmDCFGLH: <RSCFDn_base> + H'0502 + (H'20 × m),
 RSCFDnCFDCmDCFGLH: <RSCFDn_base> + H'0503 + (H'20 × m)

Initial Value: H'0000 0000

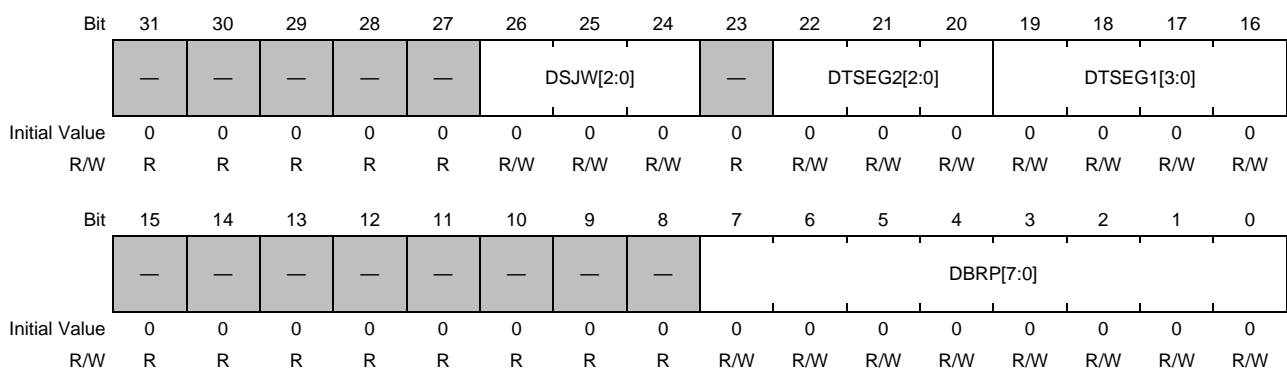

Bit	Bit Name	Initial Value	R/W	Description
31 to 27	—	All 0	R	Reserved These bits are read as the value after reset. The write value should be the value after reset.
26 to 24	DSJW[2:0]	All 0	R/W	Data Bit Rate Resynchronization Jump Width Control b26 b25 b24 0 0 0: 1 Tq 0 0 1: 2 Tq 0 1 0: 3 Tq 0 1 1: 4 Tq 1 0 0: 5 Tq 1 0 1: 6 Tq 1 1 0: 7 Tq 1 1 1: 8 Tq
23	—	0	R	Reserved This bit is read as the value after reset. The write value should be the value after reset.
22 to 20	DTSEG2[2:0]	All 0	R/W	Data Bit Rate Time Segment 2 Control b22 b21 b20 0 0 0: Setting prohibited 0 0 1: 2 Tq 0 1 0: 3 Tq 0 1 1: 4 Tq 1 0 0: 5 Tq 1 0 1: 6 Tq 1 1 0: 7 Tq 1 1 1: 8 Tq

Bit	Bit Name	Initial Value	R/W	Description
19 to 16	DTSEG1[3:0]	All 0	R/W	Data Bit Rate Time Segment 1 Control b19 b18 b17 b16 0 0 0 0: Setting prohibited 0 0 0 1: 2 Tq 0 0 1 0: 3 Tq 0 0 1 1: 4 Tq 0 1 0 0: 5 Tq 0 1 0 1: 6 Tq 0 1 1 0: 7 Tq 0 1 1 1: 8 Tq 1 0 0 0: 9 Tq 1 0 0 1: 10 Tq 1 0 1 0: 11 Tq 1 0 1 1: 12 Tq 1 1 0 0: 13 Tq 1 1 0 1: 14 Tq 1 1 1 0: 15 Tq 1 1 1 1: 16 Tq
15 to 8	—	All 0	R	Reserved These bits are read as the value after reset. The write value should be the value after reset.
7 to 0	DBRP[7:0]	All 0	R/W	Data Bit Rate Prescaler Division Ratio Setting When the set value = P (0 to 255), the data bit rate prescaler divides fCAN by (P + 1).

Modify the RSCFDnCFDCmDCFG register in channel reset mode or channel halt mode. Set this register in channel reset mode, and then transition to channel communication mode or channel halt mode. When only classical CAN frames are used in CANFD mode, set the RSCFDnCFDCmDCFG register to the value equal to the set RSCFDnCFDCmNCFG register value. For the description and settings of bit timing parameters, see **Section 28.11.1, Initial Settings**.

DSJW[2:0] Bits

These bits specify the resynchronization jump width of data bit rate as a Tq value. A value of 1 to 8 Tq is settable. Specify a value equal to or smaller than the DTSEG2[2:0] bits value.

DTSEG2[2:0] Bits

These bits are used to specify a Tq value for the length of phase segment 2 (PHASE_SEG2) of nominal bit rate. Allowed values are 2 Tq to 8 Tq, inclusive.

Set a value smaller than the value of the DTSEG1[3:0] bits.

DTSEG1[3:0] Bits

These bits specify the total length of propagation segment (PROP_SEG) and phase segment 1 (PHASE_SEG1) of data bit rate as a Tq value.

A value of 2 to 16 Tq is settable.

DBRP[7:0] Bits

The clock obtained by dividing the CAN clock (f_{CAN}) by the data bit rate prescaler ($(DBRP[7:0] + 1)$) becomes CANmTq(D) clock ($f_{CANTQ(D)m}$). One clock of the CANmTq(D) clock becomes one Time Quantum (Tq).

Make sure to set the same value in the NBRP[9:0] bits and the DBRP[7:0] bits. To set the nominal bit rate and data bit rate of different values, change the NTSEG 1 bit and NTSEG 2 bit in the RSCFDnCFDCmNCFG register and the DTSEG 1 bit and DTSEG 2 bit in the RSCFDnCFDCmDCFG register to the desired bit rate values respectively. When the TDCE bit of the RSCFDnCFDCmFDCFG register is 1 (transmission delay correction enabled), set the same value of 1 or less to the NBRP [9:0] and DBRP [7:0] bits.

28.4.3.6 RSCFDnCFDCmFDCFG — Channel CANFD Configuration Register (m = 0, 1)

Access Size: RSCFDnCFDCmFDCFG register can be read/written in 32-bit units
 RSCFDnCFDCmFDCFGL, RSCFDnCFDCmFDCFGH registers can be read/written in 16-bit units
 RSCFDnCFDCmFDCFGLL, RSCFDnCFDCmFDCFGLH, RSCFDnCFDCmFDCFGHL,
 RSCFDnCFDCmFDCFGHH registers can be read/written in 8-bit units

Address(es): RSCFDnCFDCmFDCFG: <RSCFDn_base> + H'0504 + (H'20 × m)
 RSCFDnCFDCmFDCFGL: <RSCFDn_base> + H'0504 + (H'20 × m),
 RSCFDnCFDCmFDCFGH: <RSCFDn_base> + H'0506 + (H'20 × m)
 RSCFDnCFDCmFDCFGLL: <RSCFDn_base> + H'0504 + (H'20 × m),
 RSCFDnCFDCmFDCFGLH: <RSCFDn_base> + H'0505 + (H'20 × m),
 RSCFDnCFDCmFDCFGHL: <RSCFDn_base> + H'0506 + (H'20 × m),
 RSCFDnCFDCmFDCFGHH: <RSCFDn_base> + H'0507 + (H'20 × m)

Initial Value: H'0000 0000

Bit	31	30	29	28	27	26	25	24	23	22	21	20	19	18	17	16
	—	—	REFE	FDOE	TMME	GWBR	GWDF	GWEN	—	TDCO[6:0]						
Initial Value	0	0	0	0	0	0	0	0	0	0	0	0	0	0	0	0
R/W	R	R	R/W	R/W	R/W	R/W	R/W	R/W	R	R/W	R/W	R/W	R/W	R/W	R/W	R/W
Bit	15	14	13	12	11	10	9	8	7	6	5	4	3	2	1	0
	—	—	—	—	—	ESIC	TDCE	TDCOC	—	—	—	—	—	EOCCFG[2:0]		
Initial Value	0	0	0	0	0	0	0	0	0	0	0	0	0	0	0	0
R/W	R	R	R	R	R	R/W	R/W	R/W	R	R	R	R	R	R/W	R/W	R/W

Bit	Bit Name	Initial Value	R/W	Description
31, 30	—	All 0	R	Reserved These bits are read as the value after reset. The write value should be the value after reset.
29	REFE	0	R/W	Reception data edge filter enable bit 0: Reception data edge filter disabled 1: Reception data edge filter enabled
28	FDOE	0	R/W	FD-only mode enable bit 0: FD-only mode disabled 1: FD-only mode enabled
27	TMME	0	R/W	Transmit Buffer Merge Mode Enable 0: Transmit buffer merge mode is disabled. 1: Transmit buffer merge mode is enabled.
26	GWBR	0	R/W	Gateway BRS 0: A frame is transmitted with the BRS bit in the received frame set to 0. 1: A frame is transmitted with the BRS bit in the received frame set to 1.
25	GWDF	0	R/W	Gateway FDF 0: A frame is transmitted regarding the received frame as a classical CAN frame. 1: A frame is transmitted regarding the received frame as a CANFD frame.
24	GWEN	0	R/W	CAN-CANFD Gateway Enable 0: The CAN-CANFD gateway is disabled. 1: The CAN-CANFD gateway is enabled.
23	—	0	R	Reserved This bit is read as the value after reset. The write value should be the value after reset.

Bit	Bit Name	Initial Value	R/W	Description																																				
22 to 16	TDCO[6:0]	All 0	R/W	Transmitter Delay Compensation Offset These bits are set to the transmitter delay compensation offset value.																																				
15 to 11	—	All 0	R	Reserved These bits are read as the value after reset. The write value should be the value after reset.																																				
10	ESIC	0	R/W	Error State Display Mode Select 0: Always displays the node error state. 1: When the node is not in the error passive state: Displays the message buffer error state. When the node is in the error passive state: Displays the node error state.																																				
9	TDCE	0	R/W	Transmitter Delay Compensation Enable 0: Transmitter delay compensation is disabled. 1: Transmitter delay compensation is enabled.																																				
8	TDCOC	0	R/W	Transmitter Delay Compensation Measurement Select 0: Measurement and offset 1: Only offset																																				
7 to 3	—	All 0	R	Reserved These bits are read as the value after reset. The write value should be the value after reset.																																				
2 to 0	EOCCFG[2:0]	All 0	R/W	Error Occurrence Counting Method Select <table border="0" style="margin-left: 20px;"> <tr> <td>b2</td> <td>b1</td> <td>b0</td> <td></td> </tr> <tr> <td>0</td> <td>0</td> <td>0</td> <td>0: All transmit messages and receive messages</td> </tr> <tr> <td>0</td> <td>0</td> <td>1</td> <td>1: All transmit messages</td> </tr> <tr> <td>0</td> <td>1</td> <td>0</td> <td>0: All receive messages</td> </tr> <tr> <td>0</td> <td>1</td> <td>1</td> <td>1: Setting prohibited</td> </tr> <tr> <td>1</td> <td>0</td> <td>0</td> <td>0: Only data phase of transmitted or received CANFD message</td> </tr> <tr> <td>1</td> <td>0</td> <td>1</td> <td>1: Only data phase of transmitted CANFD message</td> </tr> <tr> <td>1</td> <td>1</td> <td>0</td> <td>0: Only data phase of received CANFD message</td> </tr> <tr> <td>1</td> <td>1</td> <td>1</td> <td>1: Setting prohibited</td> </tr> </table>	b2	b1	b0		0	0	0	0: All transmit messages and receive messages	0	0	1	1: All transmit messages	0	1	0	0: All receive messages	0	1	1	1: Setting prohibited	1	0	0	0: Only data phase of transmitted or received CANFD message	1	0	1	1: Only data phase of transmitted CANFD message	1	1	0	0: Only data phase of received CANFD message	1	1	1	1: Setting prohibited
b2	b1	b0																																						
0	0	0	0: All transmit messages and receive messages																																					
0	0	1	1: All transmit messages																																					
0	1	0	0: All receive messages																																					
0	1	1	1: Setting prohibited																																					
1	0	0	0: Only data phase of transmitted or received CANFD message																																					
1	0	1	1: Only data phase of transmitted CANFD message																																					
1	1	0	0: Only data phase of received CANFD message																																					
1	1	1	1: Setting prohibited																																					

REFE bit

Setting this bit to 1 enables reception data edge filtering when the idle condition is detected, and a dominant level with less than 2 time quanta is ignored. A dominant level with more than or equal to 2 time quanta is detected as an edge. Modify this bit only in channel reset mode.

FDOE bit

Setting this bit to 1 enables FD-only mode. When data is transmitted, a CANFD frame will be sent regardless of the settings to the CFFDF bit in the RSCFDnCFDCFFDCSTSk register or the TMFDF bit in the RSCFDnCFDTMFDCTRp register. When a Classical CAN frame is received, a form error is detected. Modify this bit only in channel reset mode.

TMME Bit

Setting this bit to 1 enables transmit buffer merge mode. Modify this bit only in channel reset mode or channel halt mode.

GWBRs Bit

When the GWEN bit is 1, the BRS bit in a CANFD frame to be transmitted by the gateway function is set. Write 0 to this bit to clear the GWBRs bit to 0. Modify this bit only in channel reset mode.

GWDF Bit

When the GWEN bit is 1, the FDF bit in a CANFD frame to be transmitted by the gateway function is set. Modify this bit only in channel reset mode.

GWEN Bit

This bit is used to control the operation of the transmit/receive FIFO buffer with the CFM[1:0] bits in the RSCFDnCFDCFCCK register set to 10b (gateway mode).

Setting this bit to 1 enables the CAN-CANFD gateway, enabling transmission in a format different from that of frames received by the gateway function. Received frames are replaced in accordance with the settings of the GWDF bit and the GWBRS bit. When the DLC value in the received classical CAN frame is 1001b or more and the GWDF bit is 1 (CANFD frame), the DLC value is replaced with 1000b.

While this bit is 1, do not perform routing the following frames by using the gateway function.

- CANFD frames with a payload length of more than 8 bytes
- Remote frames

While this bit is 1, the following frame should be transmitted in the channel by setting of GWDF.

- When GWDF bit is set to 0, only classical CAN frames should be transmitted.
- When GWDF bit is set to 1, only CANFD frames should be transmitted.

Table 28.25 shows the settings and formats of transmit frame and receive frame while the CAN-CANFD gateway is enabled.

Table 28.25 Operation when the CAN-CANFD Gateway is Enabled

Receive Frame				Transmit Frame		
Format	BRS Bit	Received DLC Value	GWDF Bit	Format	BRS Bit	DLC Value to be Transmitted
Classical CAN	None	DLC ≤ 1000b	0	Classical CAN	None	Not replaced
		DLC > 1000b				
CANFD	Arbitrary	DLC ≤ 1000b	1	CANFD	According to GWBRS bit setting	Not replaced
Classical CAN	None	DLC ≤ 1000b				
		DLC > 1000b				
CANFD	Arbitrary	DLC ≤ 1000b	Not replaced			

TDCO[6:0] Bits

These bits are set to the SSP offset value. How to use this value depends on the TDCOC bit in the RSCFDnCFDCmFDCFG register.

When the TDCOC bit is 0, the transmitter delay compensation result equals to the total value of the measured delay value and the TDCO[6:0] value (rounded to the nearest integer T_q).

When the TDCOC bit is 1, the transmitter delay compensation result equals to the TDCO[6:0] value. The SSP offset value = (set value of TDCO[6:0] bits + 1).

Modify these bits only in channel reset mode or channel halt mode.

ESIC Bit

When the ESIC bit is set to 1, if the channel is in the error active state, the ESI bit value (CFESI bit in the RSCFDnCFDCFFDCSTSk register or TMESI bit in the RSCFDnCFDTMFDCTRp register) set in the transmit/receive FIFO buffer or transmit buffer is transmitted as an ESI bit value of the transmit message. When the channel is in the error passive state or the ESIC bit is 0, the channel status is transmitted as an ESI bit value. Modify this bit only in channel reset mode or channel halt mode.

Table 28.26 ESI Value to Be Transmitted

ESIC Bit	Channel Status	ESI Value to be Transmitted
0	Error active	0 (error active node)
	Error passive	1 (error passive node)
1	Error active	ESI value set in the transmit/receive FIFO buffer or transmit buffer CFESI bit in the RSCFDnCFDCFFDCSTSk register or TMESI bit in the RSCFDnCFDTMFDCTRp register)
	Error passive	1 (error passive node)

TDCE Bit

Setting this bit to 1 enables transmitter delay compensation. Modify this bit only in channel reset mode or channel halt mode.

TDCOC Bit

When this bit is 0, the SSP position is defined by the total of the measured delay value and the SSP offset value (fixed value).

When this bit is 1, the SSP position is defined only by the SSP offset value. Modify this bit only in channel reset mode or channel halt mode.

EOCCFG[2:0] Bits

These bits are used to select a frame format and a transmission/reception direction when the error occurrence counter counts CAN bus errors.

Modify these bits only in channel reset mode or channel halt mode.

28.4.3.7 RSCFDnCFDCmFDCTR — Channel CANFD Control Register (m = 0, 1)

Access Size: RSCFDnCFDCmFDCTR register can be read/written in 32-bit units
 RSCFDnCFDCmFDCTRL, RSCFDnCFDCmFDCTRH registers can be read/written in 16-bit units
 RSCFDnCFDCmFDCTRL, RSCFDnCFDCmFDCTRLH, RSCFDnCFDCmFDCTRHL,
 RSCFDnCFDCmFDCTRHH registers can be read/written in 8-bit units

Address(es): RSCFDnCFDCmFDCTR: <RSCFDn_base> + H'0508 + (H'20 × m)
 RSCFDnCFDCmFDCTRL: <RSCFDn_base> + H'0508 + (H'20 × m),
 RSCFDnCFDCmFDCTRH: <RSCFDn_base> + H'050A + (H'20 × m)
 RSCFDnCFDCmFDCTRL: <RSCFDn_base> + H'0508 + (H'20 × m),
 RSCFDnCFDCmFDCTRLH: <RSCFDn_base> + H'0509 + (H'20 × m),
 RSCFDnCFDCmFDCTRHL: <RSCFDn_base> + H'050A + (H'20 × m),
 RSCFDnCFDCmFDCTRHH: <RSCFDn_base> + H'050B + (H'20 × m)

Initial Value: H'0000 0000

Bit	31	30	29	28	27	26	25	24	23	22	21	20	19	18	17	16
	—	—	—	—	—	—	—	—	—	—	—	—	—	—	—	—
Initial Value	0	0	0	0	0	0	0	0	0	0	0	0	0	0	0	0
R/W	R	R	R	R	R	R	R	R	R	R	R	R	R	R	R	R
Bit	15	14	13	12	11	10	9	8	7	6	5	4	3	2	1	0
	—	—	—	—	—	—	—	—	—	—	—	—	—	—	SOCCLR	EOCCLR
															R	R
Initial Value	0	0	0	0	0	0	0	0	0	0	0	0	0	0	0	0
R/W	R	R	R	R	R	R	R	R	R	R	R	R	R	R	R/W	R/W

Bit	Bit Name	Initial Value	R/W	Description
31 to 2	—	All 0	R	Reserved These bits are read as the value after reset. The write value should be the value after reset.
1	SOCCLR	0	R/W	Successful Occurrence Counter Clear Setting the SOCCLR bit to 1 clears the successful occurrence counter. This bit is always read as 0.
0	EOCCLR	0	R/W	Error Occurrence Counter Clear Setting the EOCCLR bit to 1 clears the error occurrence counter. This bit is always read as 0.

SOCCLR Bit

Setting this bit to 1 clears the successful occurrence counter (SOC[7:0] bits in the RSCFDnCFDCmFDSTS register). This bit is automatically cleared to 0.

EOCCLR Bit

Setting this bit to 1 clears the error occurrence counter (EOC[7:0] bits in the RSCFDnCFDCmFDSTS register). This bit is automatically cleared to 0.

28.4.3.8 RSCFDnCFDCmFDSTS — Channel CANFD Status Register (m = 0, 1)

Access Size: RSCFDnCFDCmFDSTS register can be read/written in 32-bit units
 RSCFDnCFDCmFDSTSL, RSCFDnCFDCmFDSTSH registers can be read/written in 16-bit units
 RSCFDnCFDCmFDSTSLL, RSCFDnCFDCmFDSTSLH, RSCFDnCFDCmFDSTSHL,
 RSCFDnCFDCmFDSTSHH registers can be read/written in 8-bit units

Address(es): RSCFDnCFDCmFDSTS: <RSCFDn_base> + H'050C + (H'20 × m)
 RSCFDnCFDCmFDSTSL: <RSCFDn_base> + H'050C + (H'20 × m),
 RSCFDnCFDCmFDSTSH: <RSCFDn_base> + H'050E + (H'20 × m)
 RSCFDnCFDCmFDSTSLL: <RSCFDn_base> + H'050C + (H'20 × m),
 RSCFDnCFDCmFDSTSLH: <RSCFDn_base> + H'050D + (H'20 × m),
 RSCFDnCFDCmFDSTSHL: <RSCFDn_base> + H'050E + (H'20 × m),
 RSCFDnCFDCmFDSTSHH: <RSCFDn_base> + H'050F + (H'20 × m)

Initial Value: H'0000 0000

Bit	31	30	29	28	27	26	25	24	23	22	21	20	19	18	17	16
	SOC[7:0]								EOC[7:0]							
Initial Value	0	0	0	0	0	0	0	0	0	0	0	0	0	0	0	0
R/W	R	R	R	R	R	R	R	R	R	R	R	R	R	R	R	R
Bit	15	14	13	12	11	10	9	8	7	6	5	4	3	2	1	0
	—	—	—	—	—	—	SOCO	EOCO	TDCVF	TDCR[6:0]						
Initial Value	0	0	0	0	0	0	0	0	0	0	0	0	0	0	0	0
R/W	R	R	R	R	R	R	R/W*1	R/W*1	R/W*1	R	R	R	R	R	R	R

Bit	Bit Name	Initial Value	R/W	Description
31 to 24	SOC[7:0]	All 0	R	Successful Occurrence Counter The successful occurrence counter value can be read.
23 to 16	EOC[7:0]	All 0	R	Error Occurrence Counter The error occurrence counter value can be read.
15 to 10	—	All 0	R	Reserved When read, the value after reset is returned. When writing to these bits, write the value after reset.
9	SOCO	0	R/W*1	Successful Occurrence Counter Overflow Flag 0: The successful occurrence counter does not overflow. 1: The successful occurrence counter has overflowed.
8	EOCO	0	R/W*1	Error Occurrence Counter Overflow Flag 0: The error occurrence counter does not overflow. 1: The error occurrence counter has overflowed.
7	TDCVF	0	R/W*1	Transmitter Delay Compensation Violation Flag 0: No transmitter delay compensation violation is present. 1: A transmitter delay compensation violation is present.
6 to 0	TDCR[6:0]	All 0	R	Transmitter Delay Compensation Result Status The transmitter delay compensation result can be read.

Note 1. The only effective value for writing to this flag bit is 0, which clears the bit. Otherwise writing to the bit results in retention of its state.

SOC[7:0] Bits

These bits show the successful occurrence counter value. The successful occurrence counter is incremented upon completion of message reception or transmission without an error. This counter stops counting when it reaches H'FF. In loopback mode, this counter is incremented twice.

These bits are cleared to 0 by writing 1 to the SOCCLR bit in the RSCFDnCFDCmCTR register. These bits are 0 in channel reset mode.

EOC[7:0] Bits

These bits show the error occurrence counter value. The error occurrence counter is incremented each time an error occurs according to the condition specified by the EOCCFG[2:0] bits in the RSCFDnCFDCmFDCFG register. This counter stops counting when it reaches H'FF.

These bits are cleared to 0 by writing 1 to the EOCCLR bit in the RSCFDnCFDCmCTR register. These bits are 0 in channel reset mode.

SOCO Flag

This bit indicates that successful occurrence counter overflow has occurred.

This flag is set to 1 when message reception or transmission is completed while the SOC[7:0] value has reached H'FF. This flag is 0 in channel reset mode.

EOCO Flag

This bit indicates that error occurrence counter overflow has occurred.

This flag is set to 1 when a CAN bus error is detected under the condition specified by the EOCCFG[2:0] bits in the RSCFDnCFDCmFDCFG register when the EOC[7:0] value has reached H'FF. This flag is 0 in channel reset mode.

TDCVF Flag

This bit indicates violation of transmitter delay compensation.

The transmit data is compared with the reception CAN bus level delayed due to the transceiver's loop delay. This delay changes due to physical factors such as temperature. Because the TDCR[6:0] flags are updated for each message, temporary maximum delay cannot be confirmed.

This bit is set to 1 when the transmitter delay compensation exceeds the maximum compensation $3 \text{ CANm bit times} - 2 \text{ Tq}$ (CANm bit time and Tq are the values of data bit rate).

This flag is 0 in channel reset mode.

TDCR[6:0] Flags

These bits indicate the transmitter delay compensation result as a multiple of CAN clock frequency (fCAN).

This result depends on the settings of the TDCOC bit and TDCO[6:0] bits in the RSCFDnCFDCmFDCFG register.

This flag is updated at a falling edge between the FDF bit and res bit when the TDCE bit (transmitter delay compensation enable) in the RSCFDnCFDCmFDCFG register is set to 1 and also the TDCOC bit (transmitter delay compensation measurement select) in the RSCFDnCFDCmFDCFG register is set to 0.

This flag is 0 in channel reset mode.

28.4.3.9 RSCFDnCFDCmFDCRC — Channel CANFD CRC Register (m = 0, 1)

Access Size: RSCFDnCFDCmFDCRC register can be read only in 32-bit units
 RSCFDnCFDCmFDCRCL, RSCFDnCFDCmFDCRCH registers can be read only in 16-bit units
 RSCFDnCFDCmFDCRCLL, RSCFDnCFDCmFDCRCLH, RSCFDnCFDCmFDCRCHL,
 RSCFDnCFDCmFDCRCHH registers can be read only in 8-bit units

Address(es): RSCFDnCFDCmFDCRC: <RSCFDn_base> + H'0510 + (H'20 × m)
 RSCFDnCFDCmFDCRCL: <RSCFDn_base> + H'0510 + (H'20 × m),
 RSCFDnCFDCmFDCRCH: <RSCFDn_base> + H'0512 + (H'20 × m)
 RSCFDnCFDCmFDCRCLL: <RSCFDn_base> + H'0510 + (H'20 × m),
 RSCFDnCFDCmFDCRCLH: <RSCFDn_base> + H'0511 + (H'20 × m),
 RSCFDnCFDCmFDCRCHL: <RSCFDn_base> + H'0512 + (H'20 × m),
 RSCFDnCFDCmFDCRCHH: <RSCFDn_base> + H'0513 + (H'20 × m)

Initial Value: H'0000 0000

Bit	31	30	29	28	27	26	25	24	23	22	21	20	19	18	17	16
	—				SCNT[3:0]				—			CRCREG[20:16]				
Initial Value	0	0	0	0	0	0	0	0	0	0	0	0	0	0	0	0
R/W	R	R	R	R	R	R	R	R	R	R	R	R	R	R	R	R
Bit	15	14	13	12	11	10	9	8	7	6	5	4	3	2	1	0
	CRCREG[15:0]															
Initial Value	0	0	0	0	0	0	0	0	0	0	0	0	0	0	0	0
R/W	R	R	R	R	R	R	R	R	R	R	R	R	R	R	R	R

Bit	Bit Name	Initial Value	R/W	Description
31 to 28	—	All 0	R	Reserved These bits are read as the value after reset.
27 to 24	SCNT[3:0]	All 0	R	Stuff count Indicate a value of the stuff count in a CANFD frame. Bits 25 to 27 indicate the Gray-coded value of the stuff bit count modulo 8 in the transmitted/received frames. Bit 24 indicates an even parity value of bits 25 to 27.
23 to 21	—	All 0	R	Reserved These bits are read as the value after reset.
20 to 0	CRCREG [20:0]	All 0	R	CRC Calculation Data (CRC Length:17 Bits or 21 Bits) These bits show the CRC value calculated based on the transmit message or receive message. When the CRC length is 17 bits, bits b20 to b17 are read as 0.

SCNT[3:0] Flag

When the CTME bit in the RSCFDnCFDCmCTR register is set to 1 (communication test mode enabled), a stuff count bit value of the CANFD frame can be read if a message transmitted/received is a CANFD frame. When the CTME bit is 0 (communication test mode disabled), this flag is always read as 0. This flag is updated at the first bit in the CRC field of the CANFD frame. These bits are cleared to 0 in channel reset mode.

CRCREG[20:0] Flag

When the CTME bit in the RSCFDnCFDCmCTR register is 1 (communication test mode enabled), if transmit or receive message is a CANFD frame (CRC length = 17 or 21 bits), this flag is updated and the CRC value calculated based on the message can be read. When the CRC length of the message is 17 bits, bits b20 to b17 are always read as 0. When a classical CAN frame is transmitted or received, the CRCREG[14:0] value in the RSCFDnCFDCmERFL register is updated. When the CTME bit is 0 (communication test mode disabled), these bits are always read as 0.

28.4.4 Details of Global-related Registers

28.4.4.1 SCFDnCFDGCFCG — Global Configuration Register

Access Size: RSCFDnCFDGCFCG register can be read/written in 32-bit units
 RSCFDnCFDGCFCGL, RSCFDnCFDGCFCGH registers can be read/written in 16-bit units
 RSCFDnCFDGCFCGLL, RSCFDnCFDGCFCGLH, RSCFDnCFDGCFCGHL, RSCFDnCFDGCFCGHH registers can be read/written in 8-bit units

Address(es): RSCFDnCFDGCFCG: <RSCFDn_base> + H'0084
 RSCFDnCFDGCFCGL: <RSCFDn_base> + H'0084, RSCFDnCFDGCFCGH: <RSCFDn_base> + H'0086
 RSCFDnCFDGCFCGLL: <RSCFDn_base> + H'0084, RSCFDnCFDGCFCGLH: <RSCFDn_base> + H'0085,
 RSCFDnCFDGCFCGHL: <RSCFDn_base> + H'0086, RSCFDnCFDGCFCGHH: <RSCFDn_base> + H'0087

Initial Value: H'0000 0000

Bit	31	30	29	28	27	26	25	24	23	22	21	20	19	18	17	16
	ITRCP[15:0]															
Initial Value	0	0	0	0	0	0	0	0	0	0	0	0	0	0	0	0
R/W	R/W	R/W	R/W	R/W	R/W	R/W	R/W	R/W	R/W	R/W	R/W	R/W	R/W	R/W	R/W	R/W
Bit	15	14	13	12	11	10	9	8	7	6	5	4	3	2	1	0
	TSBTCS[2:0]		TSSS		TSP[3:0]			—	—	CMPOC	DCS	MME	DRE	DCE	TPRI	
Initial Value	0	0	0	0	0	0	0	0	0	0	0	0	0	0	0	0
R/W	R/W	R/W	R/W	R/W	R/W	R/W	R/W	R/W	R	R	R/W	R/W	R/W	R/W	R/W	R/W

Bit	Bit Name	Initial Value	R/W	Description
31 to 16	ITRCP[15:0]	All 0	R/W	Interval Timer Prescaler Set When these bits are set to M, the pclk is divided by M. Setting H'0000 is prohibited when the interval timer is in use.
15 to 13	TSBTCS[2:0]	All 0	R/W	Timestamp Clock Source Select b15 b14 b13 0 0 0: Channel 0 nominal bit time clock 0 0 1: Channel 1 nominal bit time clock 0 1 0: Channel 2 nominal bit time clock 0 1 1: Channel 3 nominal bit time clock 1 0 0: Channel 4 nominal bit time clock 1 0 1: Channel 5 nominal bit time clock 1 1 0: Setting prohibited 1 1 1: Setting prohibited
12	TSSS	0	R/W	Timestamp Source Select 0: pclk/2*1 1: Nominal bit time clock

Bit	Bit Name	Initial Value	R/W	Description
11 to 8	TSP[3:0]	0	R/W	Timestamp Clock Source Division b11 b10 b9 b8 0 0 0 0: Not divided 0 0 0 1: Divided by 2 0 0 1 0: Divided by 4 0 0 1 1: Divided by 8 0 1 0 0: Divided by 16 0 1 0 1: Divided by 32 0 1 1 0: Divided by 64 0 1 1 1: Divided by 128 1 0 0 0: Divided by 256 1 0 0 1: Divided by 512 1 0 1 0: Divided by 1024 1 0 1 1: Divided by 2048 1 1 0 0: Divided by 4096 1 1 0 1: Divided by 8192 1 1 1 0: Divided by 16384 1 1 1 1: Divided by 32768
7, 6	—	All 0	R	Reserved When read, the value after reset is returned. When writing to these bits, write the value after reset.
5	CMPOC	0	R/W	Payload Overflow Mode Select 0: No message is stored. 1: Messages are stored and payloads exceeding the buffer size are discarded.
4	DCS	0	R/W	CAN Clock Source Select*2 0: clk 1: clk_xincan
3	MME	0	R/W	Mirror Function Enable 0: Mirror function is disabled. 1: Mirror function is enabled.
2	DRE	0	R/W	DLC Replacement Enable 0: DLC replacement is disabled. 1: DLC replacement is enabled.
1	DCE	0	R/W	DLC Check Enable 0: DLC check is disabled. 1: DLC check is enabled.
0	TPRI	0	R/W	Transmit Priority Select 0: ID priority 1: Transmit buffer number priority

Note 1. When specifying pclk/2 as the timestamp counter count source, set bits TSBTCS[2:0] to 000b.

Note 2. For the CAN clock frequency settings, see **Section 28.1.3, Clock Supply**.

Modify the RSCFDnCFDGCFCFG register only in global reset mode.

ITRCP[15:0] Bits

These bits are used to set a clock source division value of the interval timer for FIFO buffers. See **Section 28.8.3.1, Interval Transmission Function**.

TSBTCS[2:0] Bits

When the TSSS bit is 1, these bits are used to select the channel of the nominal bit time clock that will be the clock source of the timestamp counter. However, do not select the channel that handles the CANFD frames.

TSSS Bit

This bit is used to select a clock source of the timestamp counter. Select pclk if there is no channel that handles only classical CAN frames.

TSP[3:0] Bits

A clock obtained by dividing the clock source selected with the TSBTCS[2:0] bits and TSSS bit according to the TSP[3:0] bits is used as the timestamp counter count source.

CMPOC Bit

This bit is used to select operation in case the payload length of received message exceeds the payload storage size of the storage buffer.

When this bit is 0, the received message in which the payload overflows is not stored in the buffer.

When this bit is 1, the received message in which the payload overflows is stored in the buffer. At this time, payloads exceeding the buffer's payload storage size are discarded.

The buffer's payload storage size is set by the following bits.

- Receive buffer: RMPLS[1:0] bits in the RSCFDnCFDRMNB register
- Receive FIFO buffer: RFPLS[2:0] bits in the RSCFDnCFDRFCCx register
- Transmit/receive FIFO buffer: CFPLS[2:0] bits in the RSCFDnCFDCFCCK register

DCS Bit

When this bit is set to 0, clkc is used as the clock source of the CAN clock (fCAN).

When this bit is set to 1, clk_xincan is used as the clock source of the CAN clock (fCAN).

For the CAN clock frequency settings, see **Table 28.6, Range of Operating Frequency Depending on the Transfer Rate and the Number of Channels in Use in this LSI.**

MME Bit

Setting this bit to 1 makes the mirror function available.

DRE Bit

When the DRE bit is set to 1, the DLC value of the receive rule is stored in the buffer instead of the DLC value of the received message after the DLC value has passed through the DLC filter. In this case, a value of H'00 is stored in each data byte beyond the DLC value of the receive rule.

The DLC replacement function is only available when the DCE bit is set to 1 (DLC check is enabled).

DCE Bit

Setting this bit to 1 makes the DLC check function available. When disabling the DLC check function, set the GAFLDLC[3:0] bits in the RSCFDnCFDGAFLP0_j register to 0000b before clearing the DCE bit in the RSCFDnCFDGCFCFG register to 0.

TPRI Bit

This bit is used to set the transmit priority.

When this bit is set to 0, ID priority is selected and the transmit priority complies with the CAN bus arbitration rule (ISO11898-1 specifications). When this bit is set to 1, transmit buffer number priority is selected and the lowest transmit buffer number of those has the highest priority.

While the transmit queue is in use, this bit should be set to 0.

28.4.4.2 RSCFDnCFDGCTR — Global Control Register

Access Size: RSCFDnCFDGCTR register can be read/written in 32-bit units
 RSCFDnCFDGCTRL, RSCFDnCFDGCTRH registers can be read/written in 16-bit units
 RSCFDnCFDGCTRLL, RSCFDnCFDGCTRLH, RSCFDnCFDGCTRHL, RSCFDnCFDGCTRHH registers can be read/written in 8-bit units

Address(es): RSCFDnCFDGCTR: <RSCFDn_base> + H'0088
 RSCFDnCFDGCTRL: <RSCFDn_base> + H'0088, RSCFDnCFDGCTRH: <RSCFDn_base> + H'008A
 RSCFDnCFDGCTRLL: <RSCFDn_base> + H'0088, RSCFDnCFDGCTRLH: <RSCFDn_base> + H'0089,
 RSCFDnCFDGCTRHL: <RSCFDn_base> + H'008A, RSCFDnCFDGCTRHH: <RSCFDn_base> + H'008B

Initial Value: H'0000 0005

Bit	31	30	29	28	27	26	25	24	23	22	21	20	19	18	17	16
	—	—	—	—	—	—	—	—	—	—	—	—	—	—	—	TSRST
Initial Value	0	0	0	0	0	0	0	0	0	0	0	0	0	0	0	0
R/W	R	R	R	R	R	R	R	R	R	R	R	R	R	R	R	R/W
Bit	15	14	13	12	11	10	9	8	7	6	5	4	3	2	1	0
	—	—	—	—	CMPOF IE	THLEIE	MEIE	DEIE	—	—	—	—	—	GSLPR	GMDC[1:0]	
Initial Value	0	0	0	0	0	0	0	0	0	0	0	0	0	1	0	1
R/W	R	R	R	R	R/W	R/W	R/W	R/W	R	R	R	R	R	R/W	R/W	R/W

Bit	Bit Name	Initial Value	R/W	Description
31 to 17	—	All 0	R	Reserved These bits are read as the value after reset. The write value should be the value after reset.
16	TSRST	0	R/W	Timestamp Counter Reset Setting the TSRST bit to 1 resets the timestamp counter. This bit is always read as 0.
15 to 12	—	All 0	R	Reserved These bits are read as the value after reset. The write value should be the value after reset.
11	CMPOFIE	0	R/W	Payload Overflow Interrupt Enable 0: A payload overflow interrupt is disabled. 1: A payload overflow interrupt is enabled.
10	THLEIE	0	R/W	Transmit History Buffer Overflow Interrupt Enable 0: Transmit history buffer overflow interrupt is disabled. 1: Transmit history buffer overflow interrupt is enabled.
9	MEIE	0	R/W	FIFO Message Lost Interrupt Enable 0: FIFO message lost interrupt is disabled. 1: FIFO message lost interrupt is enabled.
8	DEIE	0	R/W	DLC Error Interrupt Enable 0: DLC error interrupt is disabled. 1: DLC error interrupt is enabled.
7 to 3	—	All 0	R	Reserved These bits are read as the value after reset. The write value should be the value after reset.
2	GSLPR	1	R/W	Global Stop Mode 0: Other than global stop mode 1: Global stop mode

Bit	Bit Name	Initial Value	R/W	Description
1, 0	GMDC[1:0]	01b	R/W	Global Mode Select <div style="margin-left: 20px;"> b1 b0 0 0: Global operating mode 0 1: Global reset mode 1 0: Global test mode 1 1: Setting prohibited </div>

TSRST Bit

This bit is used to reset the timestamp counter. When this bit is set to 1, the RSCFDnCFDGTSC register is cleared to H'0000.

CMPOFIE Bit

When the CMPOF flag in the RSCFDnCFDGERFL register is set to 1 after the CMPOFIE bit is set to 1, an interrupt request occurs. Modify this bit only in global reset mode.

THLEIE Bit

When the THLEIE bit is set to 1 and the THLES flag in the RSCFDnCFDGERFL register is set to 1, an interrupt request is generated. Modify this bit only in global reset mode.

MEIE Bit

When the MEIE bit is set to 1 and the MES flag in the RSCFDnCFDGERFL register is set to 1, an interrupt request is generated. Modify this bit only in global reset mode.

DEIE Bit

When the DEIE bit is set to 1 and the DEF flag in the RSCFDnCFDGERFL register is set to 1, an interrupt request is generated. Modify this bit only in global reset mode.

GSLPR Bit

Setting this bit to 1 places the RSCAN module into global stop mode.

Clearing this bit to 0 makes the RSCAN module leave from global stop mode.

This bit should not be modified in global operating mode or global test mode.

GMDC[1:0] Bits

These bits are used to select the mode of entire RS-CANFD module (global operating mode, global reset mode, or global test mode). For details, see **Section 28.6.1, Global Modes**. Setting the GSLPR bit to 1 when in global reset mode places the RS-CANFD module into global stop mode.

28.4.4.3 RSCFDnCFDGSTS — Global Status Register

Access Size: RSCFDnCFDGSTS register can be read only in 32-bit units
 RSCFDnCFDGSTSL, RSCFDnCFDGSTSH registers can be read only in 16-bit units
 RSCFDnCFDGSTSL, RSCFDnCFDGSTSLH, RSCFDnCFDGSTSHL, RSCFDnCFDGSTSHH registers can be read only in 8-bit units

Address(es): RSCFDnCFDGSTS: <RSCFDn_base> + H'008C
 RSCFDnCFDGSTSL: <RSCFDn_base> + H'008C, RSCFDnCFDGSTSH: <RSCFDn_base> + H'008E
 RSCFDnCFDGSTSL: <RSCFDn_base> + H'008C, RSCFDnCFDGSTSLH: <RSCFDn_base> + H'008D,
 RSCFDnCFDGSTSHL: <RSCFDn_base> + H'008E, RSCFDnCFDGSTSHH: <RSCFDn_base> + H'008F

Initial Value: H'0000 000D

Bit	31	30	29	28	27	26	25	24	23	22	21	20	19	18	17	16
	—	—	—	—	—	—	—	—	—	—	—	—	—	—	—	—
Initial Value	0	0	0	0	0	0	0	0	0	0	0	0	0	0	0	0
R/W	R	R	R	R	R	R	R	R	R	R	R	R	R	R	R	R
Bit	15	14	13	12	11	10	9	8	7	6	5	4	3	2	1	0
	—	—	—	—	—	—	—	—	—	—	—	—	GRAMINIT	GSLPSTS	GHLTSTS	GRSTSTS
Initial Value	0	0	0	0	0	0	0	0	0	0	0	0	1	1	0	1
R/W	R	R	R	R	R	R	R	R	R	R	R	R	R	R	R	R

Bit	Bit Name	Initial Value	R/W	Description
31 to 4	—	All 0	R	Reserved These bits are read as the value after reset.
3	GRAMINIT	1	R	CAN RAM Initialization Status Flag 0: CAN RAM initialization is completed. 1: CAN RAM initialization is ongoing.
2	GSLPSTS	1	R	Global Stop Status Flag 0: Not in global stop mode 1: In global stop mode
1	GHLTSTS	0	R	Global Test Status Flag 0: Not in global test mode 1: In global test mode
0	GRSTSTS	1	R	Global Reset Status Flag 0: Not in global reset mode 1: In global reset mode

GRAMINIT Flag

This flag indicates the initialization status of the CAN RAM.

This flag is set to 1 after the MCU has been reset, and is cleared to 0 when CAN RAM initialization is completed.

GSLPSTS Flag

This flag is set to 1 when the CAN module has transitioned to global stop mode, and is cleared to 0 when the CAN module has returned from global stop mode.

GHLTSTS Flag

This flag is set to 1 when the CAN module has transitioned to global test mode, and is cleared to 0 when the CAN module has exited global test mode.

GRSTSTS Flag

This flag is set to 1 when the CAN module has transitioned to global reset mode, and is cleared to 0 when the CAN module has exited global reset mode. This flag remains 1 even when the CAN module has transitioned from global reset mode to global stop mode.

28.4.4.4 RSCFDnCFDGERFL — Global Error Flag Register

Access Size: RSCFDnCFDGERFL register can be read/written in 32-bit units
 RSCFDnCFDGERFLL, RSCFDnCFDGERFLH registers can be read/written in 16-bit units
 RSCFDnCFDGERFLLL, RSCFDnCFDGERFLH, RSCFDnCFDGERFLHL, RSCFDnCFDGERFLHH registers can be read/written in 8-bit units

Address(es): RSCFDnCFDGERFL: <RSCFDn_base> + H'0090
 RSCFDnCFDGERFLL: <RSCFDn_base> + H'0090, RSCFDnCFDGERFLH: <RSCFDn_base> + H'0092
 RSCFDnCFDGERFLLL: <RSCFDn_base> + H'0090, RSCFDnCFDGERFLHH: <RSCFDn_base> + H'0091,
 RSCFDnCFDGERFLHL: <RSCFDn_base> + H'0092, RSCFDnCFDGERFLHH: <RSCFDn_base> + H'0093

Initial Value: H'0000 0000

Bit	31	30	29	28	27	26	25	24	23	22	21	20	19	18	17	16
	—	—	—	—	—	—	—	—	—	—	—	—	—	—	—	—
Initial Value	0	0	0	0	0	0	0	0	0	0	0	0	0	0	0	0
R/W	R	R	R	R	R	R	R	R	R	R	R	R	R	R	R	R
Bit	15	14	13	12	11	10	9	8	7	6	5	4	3	2	1	0
	—	—	—	—	—	—	—	—	—	—	—	—	CMPOF	THLES	MES	DEF
Initial Value	0	0	0	0	0	0	0	0	0	0	0	0	1	1	0	1
R/W	R	R	R	R	R	R	R	R	R	R	R	R	R/W*1	R	R	R/W*1

Bit	Bit Name	Initial Value	R/W	Description
31 to 14, 7, 6, 4	—	All 0	R	Reserved These bits are read as the value after reset. The write value should be the value after reset.
13 to 8, 5	—	All 0	R	Reserved When read, an undefined value is returned. The write value should be the value after reset.
3	CMPOF	1	R/W*1	Payload Overflow Flag 0: No payload overflow has occurred. 1: A payload overflow has occurred.
2	THLES	1	R	Transmit History Buffer Overflow Status Flag 0: No transmit history buffer overflow has occurred. 1: A transmit history buffer overflow has occurred.
1	MES	0	R	FIFO Message Lost Status Flag 0: No FIFO message lost error has occurred. 1: A FIFO message lost error has occurred.
0	DEF	1	R/W*1	DLC Error Flag 0: No DLC error has occurred. 1: A DLC error has occurred.

Note 1. The only effective value for writing to this flag bit is 0, which clears the bit. Otherwise writing to the bit results in retention of its state.

All flags in the RSCFDnCFDGERFL register are cleared to 0 in global reset mode.

CMPOF Flag

When a payload overflow occurs in any of channel m (m = 0, 1), the CMPOF flag is set to 1. This flag can be cleared to 0 by writing 0 to this bit by the program.

THLES Flag

The THLES flag is set to 1 when any one of the THLELT flags in the RSCFDnCFDTHLSTSm register (m = 0, 1) is set to 1.

This flag is cleared to 0 when the THLELT flags of all channels are set to 0.

MES Flag

The MES flag is set to 1 when any one of the RFMLT flags in the RSCFDnCFDRFSTStx register (x = 0 to 7) or the CFMLT flags in the RSCFDnCFDCFSTStk register (k = 0 to 5) is set to 1.

This flag is cleared to 0 when all RFMLT flags and CFMLT flags are set to 0.

DEF Flag

The DEF flag is set to 1 when an error has been detected during the DLC check. The program can clear this flag by writing 0 to this bit.

To clear the flags of the register to 0, the program must write 0 to the corresponding flag to be cleared. When writing 0, using store instruction, set the bit to be set to “0” to “0”, and the bits not to be set to “0” to “1”.

Note

To clear the flag of this register to 0, use a store instruction to write 0 to the given flag and 1 to the other flags.

28.4.4.5 RSCFDnCFDGTSC — Global Timestamp Counter Register

Access Size: RSCFDnCFDGTSC register can be read only in 32-bit units
RSCFDnCFDGTSC, RSCFDnCFDGTSC registers can be read only in 16-bit units

Address(es): RSCFDnCFDGTSC: <RSCFDn_base> + H'0094
RSCFDnCFDGTSC: <RSCFDn_base> + H'0094, RSCFDnCFDGTSC: <RSCFDn_base> + H'0096

Initial Value: H'0000 0000

Bit	31	30	29	28	27	26	25	24	23	22	21	20	19	18	17	16
	—	—	—	—	—	—	—	—	—	—	—	—	—	—	—	—
Initial Value	0	0	0	0	0	0	0	0	0	0	0	0	0	0	0	0
R/W	R	R	R	R	R	R	R	R	R	R	R	R	R	R	R	R
Bit	15	14	13	12	11	10	9	8	7	6	5	4	3	2	1	0
	TS[15:0]															
Initial Value	0	0	0	0	0	0	0	0	0	0	0	0	0	0	0	0
R/W	R	R	R	R	R	R	R	R	R	R	R	R	R	R	R	R

Bit	Bit Name	Initial Value	R/W	Description
31 to 16	—	All 0	R	Reserved These bits are read as the value after reset.
15 to 0	TS[15:0]	All 0	R	Timestamp Value The timestamp counter value can be read. Counter Value: H'0000 to H'FFFF

TS[15:0] Bits

When the TS[15:0] bits are read, the read value shows the timestamp counter (16-bit free-running counter) value at that time. When the SOF is detected, the TS[15:0] value is captured and later stored in the receive buffer or the FIFO buffer. Furthermore, the TS[15:0] value is stored in the transmit history buffer. The timestamp counter is initialized in global reset mode.

The timestamp counter starts and stops counting differently, depending on the count source.

- When the TSSS bit in the RSCFDnCFDGCFCFG register is 0 (pclk):
The timestamp counter starts counting when the RSCAN module has transitioned to global operating mode. This counter stops counting when the RSCAN module has transitioned to global stop mode or global test mode.
- When the TSSS bit is 1 (CANm nominal bit time clock):
The timestamp counter starts counting when the corresponding channel has transitioned to channel communication mode.
This counter stops counting when the corresponding channel has transitioned to channel reset mode or channel halt mode.

28.4.4.6 RSCFDnCFDGTINTSTS0 — Global TX Interrupt Status Register 0

Access Size: RSCFDnCFDGTINTSTS0 register can be read only in 32-bit units
 RSCFDnCFDGTINTSTS0L, RSCFDnCFDGTINTSTS0H registers can be read only in 16-bit units
 RSCFDnCFDGTINTSTS0LL, RSCFDnCFDGTINTSTS0LH, RSCFDnCFDGTINTSTS0HL,
 RSCFDnCFDGTINTSTS0HH registers can be read only in 8-bit units

Address(es): RSCFDnCFDGTINTSTS0: <RSCFDn_base> + H'0460
 RSCFDnCFDGTINTSTS0L: <RSCFDn_base> + H'0460,
 RSCFDnCFDGTINTSTS0H: <RSCFDn_base> + H'0462
 RSCFDnCFDGTINTSTS0LL: <RSCFDn_base> + H'0460,
 RSCFDnCFDGTINTSTS0LH: <RSCFDn_base> + H'0461,
 RSCFDnCFDGTINTSTS0HL: <RSCFDn_base> + H'0462,
 RSCFDnCFDGTINTSTS0HH: <RSCFDn_base> + H'0463

Initial Value: H'0000 0000

Bit	31	30	29	28	27	26	25	24	23	22	21	20	19	18	17	16
	—	—	—	—	—	—	—	—	—	—	—	—	—	—	—	—
Initial Value	0	0	0	0	0	0	0	0	0	0	0	0	0	0	0	0
R/W	R	R	R	R	R	R	R	R	R	R	R	R	R	R	R	R
Bit	15	14	13	12	11	10	9	8	7	6	5	4	3	2	1	0
	—	—	—	THIF1	CFTIF1	TQIF1	TAIF1	TSIF1	—	—	—	THIF0	CFTIF0	TQIF0	TAIF0	TSIF0
Initial Value	0	0	0	0	0	0	0	0	0	0	0	0	0	0	0	0
R/W	R	R	R	R ^{*1}	R ^{*1}	R ^{*1}	R ^{*1}	R ^{*1}	R	R	R	R ^{*1}	R ^{*1}	R ^{*1}	R ^{*1}	R ^{*1}

Bit	Bit Name	Initial Value	R/W	Description
31 to 13	—	All 0	R	Reserved These bits are read as the value after reset.
12	THIF1	0	R ^{*1}	Channel 1 Transmit History Interrupt Status Flag 0: Transmit history interrupt is not requested. 1: Transmit history interrupt is requested.
11	CFTIF1	0	R ^{*1}	Channel 1 Transmit/receive FIFO Transmit Interrupt Status Flag 0: Transmit/receive FIFO transmit interrupt is not requested. 1: Transmit/receive FIFO transmit interrupt is requested.
10	TQIF1	0	R ^{*1}	Channel 1 Transmit Queue Interrupt Status Flag 0: Transmit queue interrupt is not requested. 1: Transmit queue interrupt is requested.
9	TAIF1	0	R ^{*1}	Channel 1 Transmit Buffer Abort Interrupt Status Flag 0: Transmit buffer abort interrupt is not requested. 1: Transmit buffer abort interrupt is requested.
8	TSIF1	0	R ^{*1}	Channel 1 Transmit Buffer Interrupt Status Flag 0: Transmit buffer transmit complete interrupt is not requested. 1: Transmit buffer transmit complete interrupt is requested.
7 to 5	—	All 0	R	Reserved These bits are read as the value after reset.
4	THIF0	0	R ^{*1}	Channel 0 Transmit History Interrupt Status Flag 0: Transmit history interrupt is not requested. 1: Transmit history interrupt is requested.
3	CFTIF0	0	R ^{*1}	Channel 0 Transmit/receive FIFO Transmit Interrupt Status Flag 0: Transmit/receive FIFO transmit interrupt is not requested. 1: Transmit/receive FIFO transmit interrupt is requested.

Bit	Bit Name	Initial Value	R/W	Description
2	TQIF0	0	R*1	Channel 0 Transmit Queue Interrupt Status Flag 0: Transmit queue interrupt is not requested. 1: Transmit queue interrupt is requested.
1	TAIF0	0	R*1	Channel 0 Transmit Buffer Abort Interrupt Status Flag 0: Transmit buffer abort interrupt is not requested. 1: Transmit buffer abort interrupt is requested.
0	TSIF0	0	R*1	Channel 0 Transmit Buffer Interrupt Status Flag 0: Transmit buffer transmit complete interrupt is not requested. 1: Transmit buffer transmit complete interrupt is requested.

Note 1. This bit is automatically cleared in the global reset or channel reset mode.

TSIFm Bits

The TSIFm bit is set to 1 when the TMIEp bit in the RSCFDnCFDTMIECy register is set to 1 (transmit buffer interrupt enabled) and the TMTRF[1:0] flags in the RSCFDnCFDTMSTSp register are set to 10b (transmit completed without abort request) or 11b (transmit completed with abort request).

When the TMTRF[1:0] flags are cleared to 00b under the condition that the TSIFm bit can be set to 1, this flag is cleared to 0. In addition, clearing the TMIEp bit to 0 also clears this flag to 0.

TAIFm Bits

The TAIFm bit is set to 1 when the TAIE bit in the RSCFDnCFDCmCTR register is 1 (transmit abort interrupt enabled) and the TMTRF[1:0] flags in the RSCFDnCFDTMSTSp register are set to 01b (transmit abort completed).

This flag is cleared to 0 when the TMTRF[1:0] flags are cleared to 00b after the transmit abort is completed.

TQIFm Bits

When the TXQIE bit in the RSCFDnCFDTXQCCm register is set to 1 (transmit queue interrupt enabled) and the TXQIF bit in the RSCFDnCFDTXQSTSm register is set to 1 (transmit queue interrupt request), the TQIFm bit is set to 1.

When the TXQIF bit (transmit queue interrupt request) in the RSCFDnCFDTXQSTSm register is cleared to 0, this bit is cleared to 0. This flag is also cleared to 0 when the TXQIE bit is cleared to 0.

CFTIFm Bits

When the CFTXIE bit in the RSCFDnCFDCFCCK register is set to 1 (transmit/receive FIFO transmit interrupt enabled) and the CFTXIF bit in the RSCFDnCFDCFSTSk register is set to 1 (transmit/receive FIFO transmit interrupt request), the CFTIFm bit is set to 1.

When the CFTXIF bit is cleared to 0 under the conditions that the CFTIFm bit can be set to 1, this bit is cleared to 0. This flag is also cleared to 0 when the CFTXIE bit is cleared to 0.

THIFm Bits

When the THLIE bit in the RSCFDnCFDTHLCCm register is set to 1 (transmit history interrupt enabled) and the THLIF bit in the RSCFDnCFDTHLSTSm register is set to 1 (transmit history interrupt request), the THIFm bit is set to 1.

When the THLIF bit in the RSCFDnCFDTHLSTSm register is cleared to 0, this bit is cleared to 0. This flag is also cleared to 0 when the THLIE bit is cleared to 0.

28.4.4.7 RSCFDnCFDGFDCFG — Global FD Configuration Register

Access Size: RSCFDnCFDGFDCFG register can be read/written in 32-bit units
RSCFDnCFDGFDCFG L, RSCFDnCFDGFDCFG H registers can be read/written in 16-bit units
RSCFDnCFDGFDCFG LL, RSCFDnCFDGFDCFG LH, RSCFDnCFDGFDCFG HL, RSCFDnCFDGFDCFG HH registers can be read/written in 8-bit units

Address(es): RSCFDnCFDGFDCFG: <RSCFDn_base> + H'0474
RSCFDnCFDGFDCFG L: <RSCFDn_base> + H'0474, RSCFDnCFDGFDCFG H: <RSCFDn_base> + H'0476
RSCFDnCFDGFDCFG LL: <RSCFDn_base> + H'0474, RSCFDnCFDGFDCFG LH: <RSCFDn_base> + H'0475,
RSCFDnCFDGFDCFG HL: <RSCFDn_base> + H'0476, RSCFDnCFDGFDCFG HH: <RSCFDn_base> + H'0477

Initial Value: H'0000 0000

Bit	31	30	29	28	27	26	25	24	23	22	21	20	19	18	17	16
	—	—	—	—	—	—	—	—	—	—	—	—	—	—	—	—
Initial Value	0	0	0	0	0	0	0	0	0	0	0	0	0	0	0	0
	R/W	R/W	R/W	R/W	R/W	R/W	R/W	R/W	R/W	R/W	R/W	R/W	R/W	R/W	R/W	R/W
Bit	15	14	13	12	11	10	9	8	7	6	5	4	3	2	1	0
	—	—	—	—	—	—	TSCCFG[1:0]	—	—	—	—	—	—	—	—	PRED
Initial Value	0	0	0	0	0	0	0	0	0	0	0	0	0	0	0	0
	R/W	R/W	R/W	R/W	R/W	R/W	R/W	R/W	R/W	R/W	R/W	R/W	R/W	R/W	R/W	R/W

Bit	Bit Name	Initial Value	R/W	Description
31 to 10	—	All 0	R/W	Reserved These bits are read as the value after reset. The write value should be the value after reset.
9, 8	TSCCFG[1:0]	All 0	R/W	Time-stamp capture setting bit b9 b8 0 0: Captured at a sample point in the SOF bit. 0 1: Captured when a valid frame has been transmitted/received. 1 0: Captured at a sample point of the res bit.*1 1 1: Setting prohibited.
7 to 1	—	All 0	R/W	Reserved These bits are read as the value after reset. The write value should be the value after reset.
0	PRED	0	R/W	Protocol exception event detection disabled bit 0: Protocol exception event detection enabled 1: Protocol exception event detection disabled

Note 1. When a Classical CAN frame is transmitted/received, a time-stamp value will be captured at the sample point in the SOF bit.

TSCCFG[1:0] Bits

Select a point where a time-stamp value is captured. Modify this bit only in global reset mode.

PRED Bit

Setting this bit to 1 disables the protocol exception event detection. When a protocol exception event is detected while this bit is set to 1, the event is regarded as a form error and an error frame is output. Modify this bit only in global reset mode.

28.4.5 Details of Receive Rule-related Registers

28.4.5.1 RSCFDnCFDGAFLECTR — Receive Rule Entry Control Register

Access Size: RSCFDnCFDGAFLECTR register can be read/written in 32-bit units
 RSCFDnCFDGAFLECTRL, RSCFDnCFDGAFLECTRH registers can be read/written in 16-bit units
 RSCFDnCFDGAFLECTRLL, RSCFDnCFDGAFLECTRLH, RSCFDnCFDGAFLECTRHL,
 RSCFDnCFDGAFLECTRHH registers can be read/written in 8-bit units

Address(es): RSCFDnCFDGAFLECTR: <RSCFDn_base> + H'0098
 RSCFDnCFDGAFLECTRL: <RSCFDn_base> + H'0098,
 RSCFDnCFDGAFLECTRH: <RSCFDn_base> + H'009A
 RSCFDnCFDGAFLECTRLL: <RSCFDn_base> + H'0098,
 RSCFDnCFDGAFLECTRLH: <RSCFDn_base> + H'0099,
 RSCFDnCFDGAFLECTRHL: <RSCFDn_base> + H'009A,
 RSCFDnCFDGAFLECTRHH: <RSCFDn_base> + H'009B

Initial Value: H'0000 0000

Bit	31	30	29	28	27	26	25	24	23	22	21	20	19	18	17	16
	—	—	—	—	—	—	—	—	—	—	—	—	—	—	—	—
Initial Value	0	0	0	0	0	0	0	0	0	0	0	0	0	0	0	0
R/W	R	R	R	R	R	R	R	R	R	R	R	R	R	R	R	R
Bit	15	14	13	12	11	10	9	8	7	6	5	4	3	2	1	0
	—	—	—	—	—	—	—	AFLDAE	—	—	—	AFLPN[4:0]				
Initial Value	0	0	0	0	0	0	0	0	0	0	0	0	0	0	0	0
R/W	R	R	R	R	R	R	R	R/W	R	R	R	R/W	R/W	R/W	R/W	R/W

Bit	Bit Name	Initial Value	R/W	Description
31 to 9	—	All 0	R	Reserved These bits are read as the value after reset. The write value should be the value after reset.
8	AFLDAE	0	R/W	Receive Rule Table Write Enable 0: Receive rule table write is disabled. 1: Receive rule table write is enabled.
7 to 5	—	All 0	R	Reserved These bits are read as the value after reset. The write value should be the value after reset.
4 to 0	AFLPN[4:0]	All 0	R/W	Receive Rule Table Page Number Configuration A page number can be selected from a range of page 0 (00000b) to page 7 (00111b).

AFLDAE Bit

Setting this bit to 0 disables the write to the receive rule table. After writes to the receive rule table are completed, set this bit to 0 to disable the write to the table. The receive rule table can be read regardless of the value of this bit.

Set the AFLDAE bit to 1 only in global reset mode.

AFLPN[4:0] Bits

These bits are used to set the page number of the receive rule table. Sixteen receive rules can be set per page. Set these bits to a value within the range of 00000b to 00111b.

28.4.5.2 RSCFDnCFDGAFLCFG0 — Receive Rule Configuration Register 0

Access Size: RSCFDnCFDGAFLCFG0 register can be read/written in 32-bit units
 RSCFDnCFDGAFLCFG0L, RSCFDnCFDGAFLCFG0H registers can be read/written in 16-bit units
 RSCFDnCFDGAFLCFG0LL, RSCFDnCFDGAFLCFG0LH, RSCFDnCFDGAFLCFG0HL,
 RSCFDnCFDGAFLCFG0HH registers can be read/written in 8-bit units

Address(es): RSCFDnCFDGAFLCFG0: <RSCFDn_base> + H'009C
 RSCFDnCFDGAFLCFG0L: <RSCFDn_base> + H'009C,
 RSCFDnCFDGAFLCFG0H: <RSCFDn_base> + H'009E
 RSCFDnCFDGAFLCFG0LL: <RSCFDn_base> + H'009C,
 RSCFDnCFDGAFLCFG0LH: <RSCFDn_base> + H'009D,
 RSCFDnCFDGAFLCFG0HL: <RSCFDn_base> + H'009E,
 RSCFDnCFDGAFLCFG0HH: <RSCFDn_base> + H'009F

Initial Value: H'0000 0000

Bit	31	30	29	28	27	26	25	24	23	22	21	20	19	18	17	16
	RNC0[7:0]								RNC1[7:0]							
Initial Value	0	0	0	0	0	0	0	0	0	0	0	0	0	0	0	0
R/W	R/W	R/W	R/W	R/W	R/W	R/W	R/W	R/W	R/W	R/W	R/W	R/W	R/W	R/W	R/W	R/W
Bit	15	14	13	12	11	10	9	8	7	6	5	4	3	2	1	0
	—	—	—	—	—	—	—	—	—	—	—	—	—	—	—	—
Initial Value	0	0	0	0	0	0	0	0	0	0	0	0	0	0	0	0
R/W	R	R	R	R	R	R	R	R	R	R	R	R	R	R	R	R

Bit	Bit Name	Initial Value	R/W	Description
31 to 24	RNC0[7:0]	All 0	R/W	Number of Rules for Channel 0 Set the number of receive rules exclusively used for channel 0.
23 to 16	RNC1[7:0]	All 0	R/W	Number of Rules for Channel 1 Set the number of receive rules exclusively used for channel 1.
15 to 0	—	All 0	R	Reserved These bits are read as the value after reset. The write value should be the value after reset.

Modify the RSCFDnCFDGAFLCFG0 register only in global reset mode.

Up to 64 × (number of channels) rules can be registered in the receive rule table as the entire unit. The number of receive rules per channel should meet the following conditions.

- The maximum number of rules per channel is 128.
- The total of the number of rules allocated to each channel is not larger than the number of rules that can be registered in the entire unit.

RNC0[7:0] Bits

These bits are used to set the number of rules to be registered in the channel 0 receive rule table. Set these bits to a value within the range of H'00 to H'80.

RNC1[7:0] Bits

These bits are used to set the number of rules to be registered in the channel 1 receive rule table. Set these bits to a value within the range of H'00 to H'80.

28.4.5.3 RSCFDnCFDGAFLIDj — Receive Rule ID Register (j = 0 to 15)

Access Size: RSCFDnCFDGAFLIDj register can be read/written in 32-bit units
 RSCFDnCFDGAFLIDjL, RSCFDnCFDGAFLIDjH registers can be read/written in 16-bit units
 RSCFDnCFDGAFLIDjLL, RSCFDnCFDGAFLIDjLH, RSCFDnCFDGAFLIDjHL, RSCFDnCFDGAFLIDjHH registers can be read/written in 8-bit units

Address(es): RSCFDnCFDGAFLIDj: <RSCFDn_base> + H'1000 + (H'10 × j)
 RSCFDnCFDGAFLIDjL: <RSCFDn_base> + H'1000 + (H'10 × j),
 RSCFDnCFDGAFLIDjH: <RSCFDn_base> + H'1002 + (H'10 × j)
 RSCFDnCFDGAFLIDjLL: <RSCFDn_base> + H'1000 + (H'10 × j),
 RSCFDnCFDGAFLIDjLH: <RSCFDn_base> + H'1001 + (H'10 × j),
 RSCFDnCFDGAFLIDjHL: <RSCFDn_base> + H'1002 + (H'10 × j),
 RSCFDnCFDGAFLIDjHH: <RSCFDn_base> + H'1003 + (H'10 × j)

Initial Value: H'0000 0000

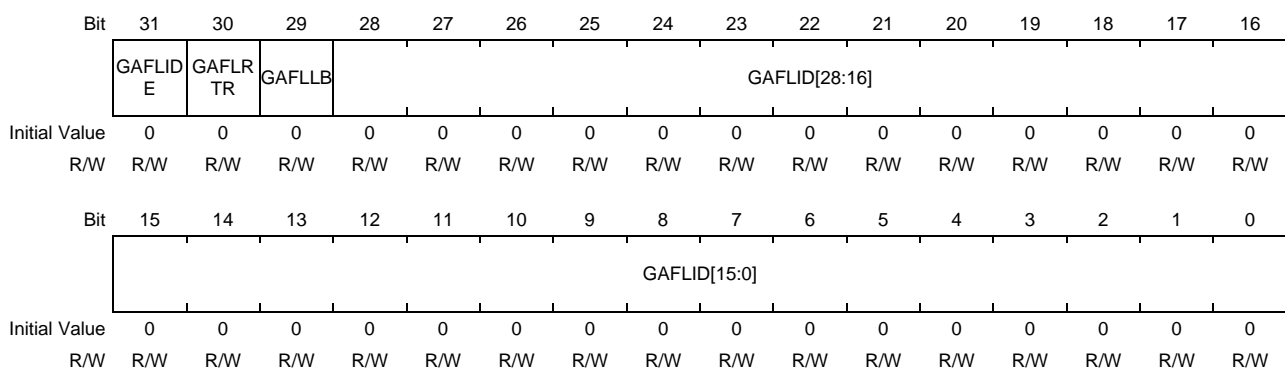

Bit	Bit Name	Initial Value	R/W	Description
31	GAFLIDE	0	R/W	IDE Select 0: Standard ID 1: Extended ID
30	GAFLRTR	0	R/W	RTR Select 0: Data frame 1: Remote frame
29	GAFLLB	0	R/W	Receive Rule Target Message Select 0: When a message transmitted from another CAN node is received 1: When the own transmitted message is received
28 to 0	GAFLID[28:0]	All 0	R/W	ID Set Set the ID of the receive rule. For the standard ID, set the ID in bits b10 to b0 and set bits b28 to b11 to 0.

Modify the RSCFDnCFDGAFLIDj register when the AFLDAE bit in the RSCFDnCFDGAFLECTR register is set to 1 (receive rule table write is enabled) in global reset mode.

GAFLIDE Bit

This bit is used to select the ID format (standard ID or extended ID) of the receive rule. This bit is compared with the IDE bit in the received message during the acceptance filter processing.

GAFLRTR Bit

This bit is used to select the frame format (data frame or remote frame) of the receive rule. This bit is compared with the RTR bit in the received message during the acceptance filter processing.

GAFLB Bit

When this bit is set to 0, data processing using the receive rule is performed when receiving messages transmitted from another CAN node.

When this bit is set to 1 when the mirror function is used, data processing using the receive rule is performed when the CAN node is receiving its own transmitted messages.

GAFLID[28:0] Bits

These bits are used to set the ID field of the receive rule. The ID value set by these bits is compared with the ID of the received message during the acceptance filter processing.

28.4.5.4 RSCFDnCFDGAFLMj — Receive Rule Mask Register (j = 0 to 15)

Access Size: RSCFDnCFDGAFLMj register can be read/written in 32-bit units
 RSCFDnCFDGAFLMjL, RSCFDnCFDGAFLMjH registers can be read/written in 16-bit units
 RSCFDnCFDGAFLMjLL, RSCFDnCFDGAFLMjLH, RSCFDnCFDGAFLMjHL, RSCFDnCFDGAFLMjHH registers can be read/written in 8-bit units

Address(es): RSCFDnCFDGAFLMj: <RSCFDn_base> + H'1004 + (H'10 × j)
 RSCFDnCFDGAFLMjL: <RSCFDn_base> + H'1004 + (H'10 × j),
 RSCFDnCFDGAFLMjH: <RSCFDn_base> + H'1006 + (H'10 × j)
 RSCFDnCFDGAFLMjLL: <RSCFDn_base> + H'1004 + (H'10 × j),
 RSCFDnCFDGAFLMjLH: <RSCFDn_base> + H'1005 + (H'10 × j),
 RSCFDnCFDGAFLMjHL: <RSCFDn_base> + H'1006 + (H'10 × j),
 RSCFDnCFDGAFLMjHH: <RSCFDn_base> + H'1007 + (H'10 × j)

Initial Value: H'0000 0000

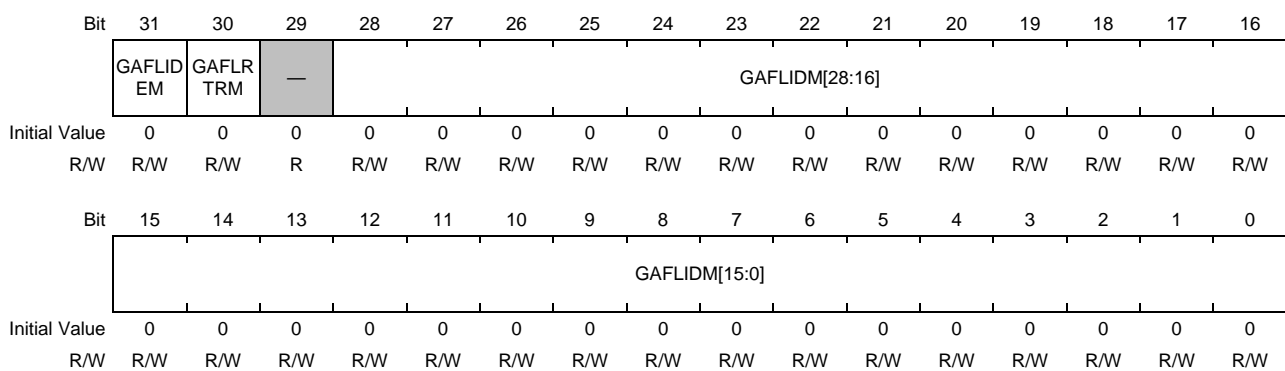

Bit	Bit Name	Initial Value	R/W	Description
31	GAFLIDEM	0	R/W	IDE Mask 0: The IDE bit is not compared. 1: The IDE bit is compared.
30	GAFLRTRM	0	R/W	RTR Mask 0: The RTR bit is not compared. 1: The RTR bit is compared
29	—	0	R	Reserved This bit is read as the value after reset. The write value should be the value after reset.
28 to 0	GAFLIDM [28:0]	All 0	R/W	ID Mask 0: The corresponding ID bit is not compared. 1: The corresponding ID bit is compared.

Modify the RSCFDnCFDGAFLMj register when the AFLDAE bit in the RSCFDnCFDGAFLECTR register is set to 1 (receive rule table write is enabled) in global reset mode.

GAFLIDEM Bit

When this bit is set to 1, filter processing is performed only for messages of the ID format specified by the GAFLIDE bit in the RSCFDnCFDGAFLIDj register.

When this bit is cleared to 0, the IDs of all the receive messages and the specified IDs are regarded as matched. To set the GAFLIDEM bit to 0, set the GAFLIDM[28:0] bits to all 0 at the same time.

GAFLRTRM Bit

This bit is used to mask the RTR bit of the receive rule.

GAFLIDM[28:0] Bits

These bits are used to mask the corresponding ID bit of the receive rule.

28.4.5.5 RSCFDnCFDGAFLP0_j — Receive Rule Pointer 0 Register (j = 0 to 15)

Access Size: RSCFDnCFDGAFLP0_j register can be read/written in 32-bit units
 RSCFDnCFDGAFLP0_jL, RSCFDnCFDGAFLP0_jH registers can be read/written in 16-bit units
 RSCFDnCFDGAFLP0_jLL, RSCFDnCFDGAFLP0_jLH, RSCFDnCFDGAFLP0_jHL, RSCFDnCFDGAFLP0_jHH registers can be read/written in 8-bit units

Address(es): RSCFDnCFDGAFLP0_j: <RSCFDn_base> + H'1008 + (H'10 × j)
 RSCFDnCFDGAFLP0_jL: <RSCFDn_base> + H'1008 + (H'10 × j),
 RSCFDnCFDGAFLP0_jH: <RSCFDn_base> + H'100A + (H'10 × j)
 RSCFDnCFDGAFLP0_jLL: <RSCFDn_base> + H'1008 + (H'10 × j),
 RSCFDnCFDGAFLP0_jLH: <RSCFDn_base> + H'1009 + (H'10 × j),
 RSCFDnCFDGAFLP0_jHL: <RSCFDn_base> + H'100A + (H'10 × j),
 RSCFDnCFDGAFLP0_jHH: <RSCFDn_base> + H'100B + (H'10 × j)

Initial Value: H'0000 0000

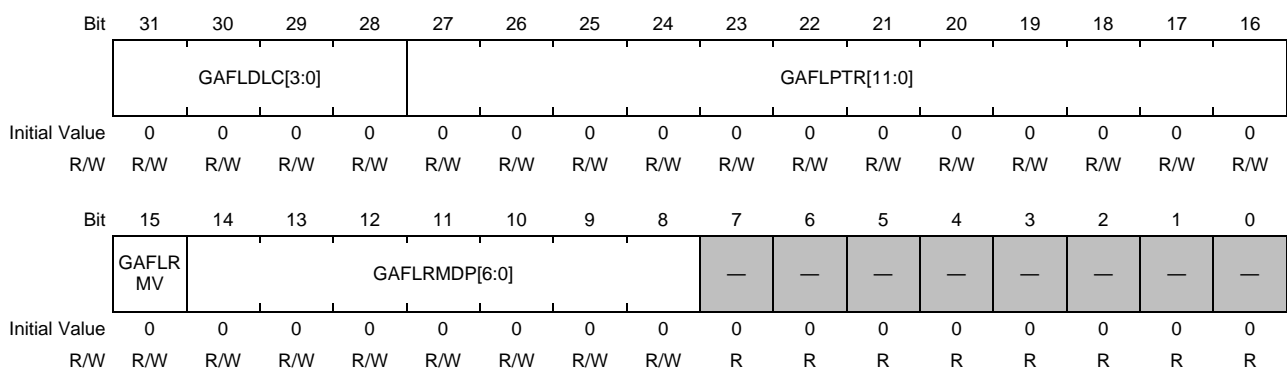

Bit	Bit Name	Initial Value	R/W	Description		
31 to 28	GAFLDLC [3:0]	All 0	R/W	Receive Rule DLC		
				b31 b30 b29 b28	Classical CAN Frame	CANFD Frame
				0 0 0 0	0 data bytes	
				0 0 0 1	1 data byte	
				0 0 1 0	2 data bytes	
				0 0 1 1	3 data bytes	
				0 1 0 0	4 data bytes	
				0 1 0 1	5 data bytes	
				0 1 1 0	6 data bytes	
				0 1 1 1	7 data bytes	
				1 0 0 0	8 data bytes	
				1 0 0 1	8 data bytes	12 data bytes
				1 0 1 0		16 data bytes
				1 0 1 1		20 data bytes
				1 1 0 0		24 data bytes
				1 1 0 1		32 data bytes
1 1 1 0		48 data bytes				
1 1 1 1		64 data bytes				
27 to 16	GAFLPTR [11:0]	All 0	R/W	Receive Rule Label Set the 12-bit label information.		
15	GAFLRMV	0	R/W	Receive Buffer Enable 0: No receive buffer is used. 1: A receive buffer is used.		
14 to 8	GAFLRMDP [6:0]	All 0	R/W	Receive Buffer Number Select Set the receive buffer number to store receive messages.		

Bit	Bit Name	Initial Value	R/W	Description
7 to 0	—	All 0	R	Reserved These bits are read as the value after reset. The write value should be the value after reset.

Modify the RSCFDnCFDGAFLP0_j register when the AFLDAE bit in the RSCFDnCFDGAFLECTR register is set to 1 (receive rule table write is enabled) in global reset mode.

GAFLDLC[3:0] Bits

These bits are used to set the minimum data length necessary for receiving messages. If the data length of a message that is being filtered is equal to or larger than the value set by the GAFLDLC[3:0] bits, the message passes the DLC check.

Setting these bits to 0000b disables the DLC check function allowing messages with any data length to pass the DLC check.

GAFLPTR[11:0] Bits

These bits are used to set a 12-bit label to be attached to messages that have passed through the filter. A label is attached when a message is stored in the receive buffer or the FIFO buffer.

GAFLRMV Bit

When this bit is set to 1, receive messages that have passed through the filter are stored in the receive buffer selected by the GAFLRMDP[6:0] bits.

GAFLRMDP[6:0] Bits

These bits are used to select the number of the receive buffer that stores receive messages that have passed through the filter when the GAFLRMV bit is set to 1. Set these bits to a value smaller than the value set by the NRXMB[7:0] bits in the RSCFDnCFDRMNB register.

28.4.5.6 RSCFDnCFDGAFLP1_j — Receive Rule Pointer 1 Register (j = 0 to 15)

Access Size: RSCFDnCFDGAFLP1_j register can be read/written in 32-bit units
 RSCFDnCFDGAFLP1_jL, RSCFDnCFDGAFLP1_jH registers can be read/written in 16-bit units
 RSCFDnCFDGAFLP1_jLL, RSCFDnCFDGAFLP1_jLH, RSCFDnCFDGAFLP1_jHL, RSCFDnCFDGAFLP1_jHH registers can be read/ written in 8-bit units

Address(es): RSCFDnCFDGAFLP1_j: <RSCFDn_base> + H'100C_H + (H'10 × j)
 RSCFDnCFDGAFLP1_jL: <RSCFDn_base> + H'100C_H + (H'10 × j),
 RSCFDnCFDGAFLP1_jH: <RSCFDn_base> + H'100E_H + (H'10 × j)
 RSCFDnCFDGAFLP1_jLL: <RSCFDn_base> + H'100C_H + (H'10 × j),
 RSCFDnCFDGAFLP1_jLH: <RSCFDn_base> + H'100D_H + (H'10 × j),
 RSCFDnCFDGAFLP1_jHL: <RSCFDn_base> + H'100E_H + (H'10 × j),
 RSCFDnCFDGAFLP1_jHH: <RSCFDn_base> + H'100F_H + (H'10 × j)

Initial Value: H'0000 0000

Bit	31	30	29	28	27	26	25	24	23	22	21	20	19	18	17	16
	—	—	—	—	—	—	—	—	—	—	—	—	—	—	—	—
Initial Value	0	0	0	0	0	0	0	0	0	0	0	0	0	0	0	0
R/W	R	R	R	R	R	R	R	R	R	R	R	R	R	R	R	R
Bit	15	14	13	12	11	10	9	8	7	6	5	4	3	2	1	0
	—	—	GAFLFDP[13:0]													
Initial Value	0	0	0	0	0	0	0	0	0	0	0	0	0	0	0	0
R/W	R	R	R/W	R/W	R/W	R/W	R/W	R/W	R/W	R/W	R/W	R/W	R/W	R/W	R/W	R/W

Bit	Bit Name	Initial Value	R/W	Description
31 to 14	—	All 0	R	Reserved These bits are read as the value after reset. The write value should be the value after reset.
13 to 8	GAFLFDP [13:8]	All 0	R/W	Transmit/Receive FIFO Buffer k Select (Bit position –8 = target transmit/receive FIFO buffer number k) 0: Transmit/receive FIFO buffer is not selected. 1: Transmit/receive FIFO buffer is selected.
7 to 0	GAFLFDP [7:0]	All 0	R/W	Receive FIFO Buffer x Select (Bit position = target receive FIFO buffer number x) 0: Receive FIFO buffer is not selected. 1: Receive FIFO buffer is selected.

Modify the RSCFDnCFDGAFLP1_j register when the AFLDAE bit in the RSCFDnCFDGAFLP1_j register is set to 1 (receive rule table write is enabled) in global reset mode.

GAFLFDP[13:0] Bits

These bits are used to specify FIFO buffers that store receive messages that have passed through the filter. Up to eight FIFO buffers are selectable. However, when the GAFLRMV bit in the RSCFDnCFDGAFLP0_j register is set to 1 (a message is stored in the receive buffer), up to seven FIFO buffers can be selected. Only receive FIFO buffers and the transmit/receive FIFO buffer for which the CFM[1:0] bits in the RSCFDnCFDGFCCk register are set to 00b (receive mode) or 10b (gateway mode) are selectable.

28.4.6 Details of Receive Buffer-related Registers

28.4.6.1 RSCFDnCFDRMNB — Receive Buffer Number Register

Access Size: RSCFDnCFDRMNB register can be read/written in 32-bit units

RSCFDnCFDRMNB, RSCFDnCFDRMNBH registers can be read/written in 16-bit units

RSCFDnCFDRMNBLL, RSCFDnCFDRMNBHL, RSCFDnCFDRMNBHL, RSCFDnCFDRMNBHH registers can be read/written in 8-bit units

Address(es): RSCFDnCFDRMNB: <RSCFDn_base> + H'00A4

RSCFDnCFDRMNB: <RSCFDn_base> + H'00A4, RSCFDnCFDRMNBH: <RSCFDn_base> + H'00A6

RSCFDnCFDRMNBLL: <RSCFDn_base> + H'00A4, RSCFDnCFDRMNBHL: <RSCFDn_base> + H'00A5,

RSCFDnCFDRMNBHL: <RSCFDn_base> + H'00A6, RSCFDnCFDRMNBHH: <RSCFDn_base> + H'00A7

Initial Value: H'0000 0000

Bit	31	30	29	28	27	26	25	24	23	22	21	20	19	18	17	16
	—	—	—	—	—	—	—	—	—	—	—	—	—	—	—	—
Initial Value	0	0	0	0	0	0	0	0	0	0	0	0	0	0	0	0
R/W	R	R	R	R	R	R	R	R	R	R	R	R	R	R	R	R
Bit	15	14	13	12	11	10	9	8	7	6	5	4	3	2	1	0
	—	—	—	—	—	—	RMPLS[1:0]		NRXMB[7:0]							
Initial Value	0	0	0	0	0	0	0	0	0	0	0	0	0	0	0	0
R/W	R	R	R	R	R	R	R/W	R/W	R/W	R/W	R/W	R/W	R/W	R/W	R/W	R/W

Bit	Bit Name	Initial Value	R/W	Description
31 to 10	—	All 0	R	Reserved These bits are read as the value after reset. The write value should be the value after reset.
9, 8	RMPLS[1:0]	All 0	R/W	Receive Buffer Payload Storage Size Select b9 b8 0 0: 8 bytes 0 1: 12 bytes 1 0: 16 bytes 1 1: 20 bytes
7 to 0	NRXMB[7:0]	All 0	R/W	Receive Buffer Number Configuration Set the number of receive buffers. Set a value of 0 to 32.

Modify the RSCFDnCFDRMNB register only in global reset mode.

RMPLS[1:0] Bits

These bits are used to select the maximum payload size that can be stored in the receive buffer.

NRXMB[7:0] Bits

These bits are used to set the total number of receive buffers of the RS-CANFD module. The maximum value is 16 × (number of channels).

Setting these bits all to 0 makes receive buffers unavailable.

28.4.6.2 RSCFDnCFDRMNDy — Receive Buffer New Data Register (y = 0)

Access Size: RSCFDnCFDRMNDy register can be read/written in 32-bit units
 RSCFDnCFDRMNDyL, RSCFDnCFDRMNDyH registers can be read/written in 16-bit units
 RSCFDnCFDRMNDyLL, RSCFDnCFDRMNDyLH, RSCFDnCFDRMNDyHL, RSCFDnCFDRMNDyHH registers can be read/written in 8-bit units

Address(es): RSCFDnCFDRMNDy: <RSCFDn_base> + H'00A8 + (H'04 × y)
 RSCFDnCFDRMNDyL: <RSCFDn_base> + H'00A8 + (H'04 × y),
 RSCFDnCFDRMNDyH: <RSCFDn_base> + H'00AA + (H'04 × y)
 RSCFDnCFDRMNDyLL: <RSCFDn_base> + H'00A8 + (H'04 × y),
 RSCFDnCFDRMNDyLH: <RSCFDn_base> + H'00A9 + (H'04 × y),
 RSCFDnCFDRMNDyHL: <RSCFDn_base> + H'00AA + (H'04 × y),
 RSCFDnCFDRMNDyHH: <RSCFDn_base> + H'00AB + (H'04 × y)

Initial Value: H'0000 0000

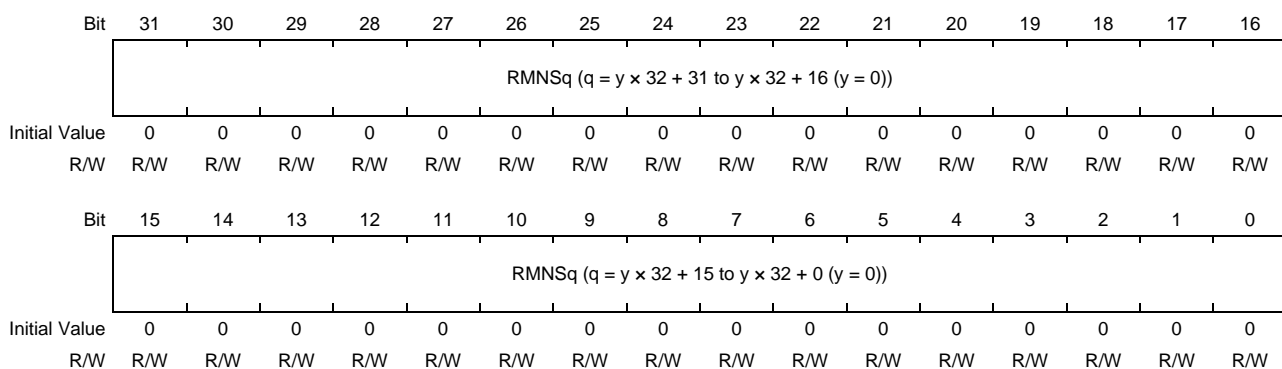

Bit	Bit Name	Initial Value	R/W	Description
31 to 16	RMNSq	All 0	R/W	Receive Buffer Receive Complete Flag q (q = y × 32 + 31 to y × 32 + 16) 0: There is no new message in receive buffer q. 1: There is a new message in receive buffer q.
15 to 0	RMNSq	All 0	R/W	Receive Buffer Receive Complete Flag q (q = y × 32 + 15 to y × 32 + 0) 0: There is no new message in receive buffer q. 1: There is a new message in receive buffer q.

Write 0 to the RSCFDnCFDRMNDy register in global operating mode or global test mode.

RMNSq Flags (q = 0 to 31)

Each RMNSq flag is set to 1 when the processing for storing a message in the corresponding receive buffer starts.

To clear a flag to 0, the program must write 0 to the flag. Use a store instruction to write “0” to the flag and “1” to other flags. These bits cannot be set to 0 while a message is being stored. The message storing time depends on the storage payload size of the receive buffer. When the RMPLS[1:0] value in the RSCFDnCFDRMNB register is 00b (8 bytes), the message storing time is 12 pclk clock cycles. When the RMPLS[1:0] value is 11b (20 bytes), the message storing time is 18 pclk clock cycles. (2 pclk clock cycles per 4 bytes of storage payload size).

These flags are cleared to 0 in global reset mode.

28.4.6.3 RSCFDnCFDRMIDq — Receive Buffer ID Register (q = 0 to 31)

Access Size: RSCFDnCFDRMIDq register can be read only in 32-bit units
 RSCFDnCFDRMIDqL, RSCFDnCFDRMIDqH registers can be read only in 16-bit units
 RSCFDnCFDRMIDqLL, RSCFDnCFDRMIDqLH, RSCFDnCFDRMIDqHL, RSCFDnCFDRMIDqHH registers can be read only in 8-bit units

Address(es): RSCFDnCFDRMIDq: <RSCFDn_base> + H'2000 + (H'20 × q)
 RSCFDnCFDRMIDqL: <RSCFDn_base> + H'2000 + (H'20 × q),
 RSCFDnCFDRMIDqH: <RSCFDn_base> + H'2002 + (H'20 × q)
 RSCFDnCFDRMIDqLL: <RSCFDn_base> + H'2000 + (H'20 × q),
 RSCFDnCFDRMIDqLH: <RSCFDn_base> + H'2001 + (H'20 × q),
 RSCFDnCFDRMIDqHL: <RSCFDn_base> + H'2002 + (H'20 × q),
 RSCFDnCFDRMIDqHH: <RSCFDn_base> + H'2003 + (H'20 × q)

Initial Value: H'0000 0000

Bit	31	30	29	28	27	26	25	24	23	22	21	20	19	18	17	16
	RMIDE	RMRTR	—	RMID[28:16]												
Initial Value	0	0	0	0	0	0	0	0	0	0	0	0	0	0	0	0
R/W	R	R	R	R	R	R	R	R	R	R	R	R	R	R	R	R
Bit	15	14	13	12	11	10	9	8	7	6	5	4	3	2	1	0
	RMID[15:0]															
Initial Value	0	0	0	0	0	0	0	0	0	0	0	0	0	0	0	0
R/W	R	R	R	R	R	R	R	R	R	R	R	R	R	R	R	R

Bit	Bit Name	Initial Value	R/W	Description
31	RMIDE	0	R	Receive Buffer IDE 0: Standard ID 1: Extended ID
30	RMRTR	0	R	Receive Buffer RTR/RRS <ul style="list-style-type: none"> When the received message is a classical CAN frame 0: Data frame 1: Remote frame When the received message is a CANFD frame The RRS bit value of the received message can be read.
29	—	0	R	Reserved This bit is read as the value after reset.
28 to 0	RMID[28:0]	All 0	R	Receive Buffer ID Data These bits contain the standard ID or extended ID of the received message. Read bits b10 to b0 for standard ID. Bits b28 to b11 are read as 0.

RMIDE Bit

This bit indicates the ID format (standard ID or extended ID) of the message stored in the receive buffer.

RMRTR Bit

When the received message is a classical CAN frame, this bit indicates the frame format (data frame or remote frame) of the message stored in the receive buffer. When the received message is a CANFD frame, this bit indicates the RRS bit value in the message.

RMID[28:0] Bits

These bits contain the ID of the message stored in the receive buffer.

28.4.6.4 RSCFDnCFDRMPTRq — Receive Buffer Pointer Register (q = 0 to 31)

Access Size: RSCFDnCFDRMPTRq register can be read only in 32-bit units
 RSCFDnCFDRMPTRqL, RSCFDnCFDRMPTRqH registers can be read only in 16-bit units
 RSCFDnCFDRMPTRqLL, RSCFDnCFDRMPTRqLH, RSCFDnCFDRMPTRqHL, RSCFDnCFDRMPTRqHH registers can be read only in 8-bit units

Address(es): RSCFDnCFDRMPTRq: <RSCFDn_base> + H'2004 + (H'20 × q)
 RSCFDnCFDRMPTRqL: <RSCFDn_base> + H'2004 + (H'20 × q),
 RSCFDnCFDRMPTRqH: <RSCFDn_base> + H'2006 + (H'20 × q)
 RSCFDnCFDRMPTRqLL: <RSCFDn_base> + H'2004 + (H'20 × q),
 RSCFDnCFDRMPTRqLH: <RSCFDn_base> + H'2005 + (H'20 × q),
 RSCFDnCFDRMPTRqHL: <RSCFDn_base> + H'2006 + (H'20 × q),
 RSCFDnCFDRMPTRqHH: <RSCFDn_base> + H'2007 + (H'20 × q)

Initial Value: H'0000 0000

Bit	31	30	29	28	27	26	25	24	23	22	21	20	19	18	17	16
	RMDLC[3:0]				RMPTR[11:0]											
Initial Value	0	0	0	0	0	0	0	0	0	0	0	0	0	0	0	0
R/W	R	R	R	R	R	R	R	R	R	R	R	R	R	R	R	R
Bit	15	14	13	12	11	10	9	8	7	6	5	4	3	2	1	0
	RMTS[15:0]															
Initial Value	0	0	0	0	0	0	0	0	0	0	0	0	0	0	0	0
R/W	R	R	R	R	R	R	R	R	R	R	R	R	R	R	R	R

Bit	Bit Name	Initial Value	R/W	Description																																																																																																						
31 to 28	RMDLC[3:0]	All 0	R	Receive Buffer DLC Data																																																																																																						
				<table border="1"> <thead> <tr> <th>b31</th> <th>b30</th> <th>b29</th> <th>b28</th> <th>Classical CAN Frame</th> <th>CANFD Frame</th> </tr> </thead> <tbody> <tr><td>0</td><td>0</td><td>0</td><td>0</td><td>0 data bytes</td><td></td></tr> <tr><td>0</td><td>0</td><td>0</td><td>1</td><td>1 data byte</td><td></td></tr> <tr><td>0</td><td>0</td><td>1</td><td>0</td><td>2 data bytes</td><td></td></tr> <tr><td>0</td><td>0</td><td>1</td><td>1</td><td>3 data bytes</td><td></td></tr> <tr><td>0</td><td>1</td><td>0</td><td>0</td><td>4 data bytes</td><td></td></tr> <tr><td>0</td><td>1</td><td>0</td><td>1</td><td>5 data bytes</td><td></td></tr> <tr><td>0</td><td>1</td><td>1</td><td>0</td><td>6 data bytes</td><td></td></tr> <tr><td>0</td><td>1</td><td>1</td><td>1</td><td>7 data bytes</td><td></td></tr> <tr><td>1</td><td>0</td><td>0</td><td>0</td><td>8 data bytes</td><td></td></tr> <tr><td>1</td><td>0</td><td>0</td><td>1</td><td>8 data bytes</td><td>12 data bytes</td></tr> <tr><td>1</td><td>0</td><td>1</td><td>0</td><td></td><td>16 data bytes</td></tr> <tr><td>1</td><td>0</td><td>1</td><td>1</td><td></td><td>20 data bytes</td></tr> <tr><td>1</td><td>1</td><td>0</td><td>0</td><td></td><td>24 data bytes</td></tr> <tr><td>1</td><td>1</td><td>0</td><td>1</td><td></td><td>32 data bytes</td></tr> <tr><td>1</td><td>1</td><td>1</td><td>0</td><td></td><td>48 data bytes</td></tr> <tr><td>1</td><td>1</td><td>1</td><td>1</td><td></td><td>64 data bytes</td></tr> </tbody> </table>	b31	b30	b29	b28	Classical CAN Frame	CANFD Frame	0	0	0	0	0 data bytes		0	0	0	1	1 data byte		0	0	1	0	2 data bytes		0	0	1	1	3 data bytes		0	1	0	0	4 data bytes		0	1	0	1	5 data bytes		0	1	1	0	6 data bytes		0	1	1	1	7 data bytes		1	0	0	0	8 data bytes		1	0	0	1	8 data bytes	12 data bytes	1	0	1	0		16 data bytes	1	0	1	1		20 data bytes	1	1	0	0		24 data bytes	1	1	0	1		32 data bytes	1	1	1	0		48 data bytes	1	1	1	1		64 data bytes
b31	b30	b29	b28	Classical CAN Frame	CANFD Frame																																																																																																					
0	0	0	0	0 data bytes																																																																																																						
0	0	0	1	1 data byte																																																																																																						
0	0	1	0	2 data bytes																																																																																																						
0	0	1	1	3 data bytes																																																																																																						
0	1	0	0	4 data bytes																																																																																																						
0	1	0	1	5 data bytes																																																																																																						
0	1	1	0	6 data bytes																																																																																																						
0	1	1	1	7 data bytes																																																																																																						
1	0	0	0	8 data bytes																																																																																																						
1	0	0	1	8 data bytes	12 data bytes																																																																																																					
1	0	1	0		16 data bytes																																																																																																					
1	0	1	1		20 data bytes																																																																																																					
1	1	0	0		24 data bytes																																																																																																					
1	1	0	1		32 data bytes																																																																																																					
1	1	1	0		48 data bytes																																																																																																					
1	1	1	1		64 data bytes																																																																																																					
27 to 16	RMPTR[11:0]	All 0	R	Receive Buffer Label Data Label information of the received message.																																																																																																						
15 to 0	RMTS[15:0]	All 0	R	Receive Buffer Timestamp Data Timestamp value of the received message.																																																																																																						

RMDLC[3:0] Bits

These bits indicate the data length of the message stored in the receive buffer. The number of bytes of the payload to be stored in the receive buffer is determined by the RMPLS[1:0] bits in the RSCFDnCFDRMNB register.

RMPTR[11:0] Bits

These bits indicate the label information of the message stored in the receive buffer.

RMTS[15:0] Bits

These bits indicate the timestamp value of the message stored in the receive buffer.

28.4.6.5 RSCFDnCFDRMFDSTSq — Receive Buffer CANFD Status Register (q = 0 to 31)

Access Size: RSCFDnCFDRMFDSTSq register can be read only in 32-bit units
 RSCFDnCFDRMFDSTSqL, RSCFDnCFDRMFDSTSqH registers can be read only in 16-bit units
 RSCFDnCFDRMFDSTSqLL, RSCFDnCFDRMFDSTSqLH, RSCFDnCFDRMFDSTSqHL,
 RSCFDnCFDRMFDSTSqHH registers can be read only in 8-bit units

Address(es): RSCFDnCFDRMFDSTSq: <RSCFDn_base> + H'2008 + (H'20 × q)
 RSCFDnCFDRMFDSTSqL: <RSCFDn_base> + H'2008 + (H'20 × q),
 RSCFDnCFDRMFDSTSqH: <RSCFDn_base> + H'200A + (H'20 × q)
 RSCFDnCFDRMFDSTSqLL: <RSCFDn_base> + H'2008 + (H'20 × q),
 RSCFDnCFDRMFDSTSqLH: <RSCFDn_base> + H'2009 + (H'20 × q),
 RSCFDnCFDRMFDSTSqHL: <RSCFDn_base> + H'200A + (H'20 × q),
 RSCFDnCFDRMFDSTSqHH: <RSCFDn_base> + H'200B + (H'20 × q)

Initial Value: H'0000 0000

Bit	31	30	29	28	27	26	25	24	23	22	21	20	19	18	17	16
	—	—	—	—	—	—	—	—	—	—	—	—	—	—	—	—
Initial Value	0	0	0	0	0	0	0	0	0	0	0	0	0	0	0	0
R/W	R	R	R	R	R	R	R	R	R	R	R	R	R	R	R	R
Bit	15	14	13	12	11	10	9	8	7	6	5	4	3	2	1	0
	—	—	—	—	—	—	—	—	—	—	—	—	—	RMFDF	RMBRS	RMESI
Initial Value	0	0	0	0	0	0	0	0	0	0	0	0	0	0	0	0
R/W	R	R	R	R	R	R	R	R	R	R	R	R	R	R	R	R

Bit	Bit Name	Initial Value	R/W	Description
31 to 3	—	All 0	R	Reserved These bits are read as the value after reset.
2	RMFDF	0	R	FDF 0: Classical CAN frame 1: CANFD frame
1	RMBRS	0	R	BRS 0: The bit rate in the data area does not change. 1: The bit rate in the data area changes.
0	RMESI	0	R	ESI 0: Error active node 1: Error passive node

RMFDF Bit

This bit indicates the FD format (classical CAN frame or CANFD frame) of the message stored in the receive buffer.

RMBRS Bit

When the RMFDF bit is 1, this bit indicates the BRS bit value of the message stored in the receive buffer. When the RMFDF bit is 0, this bit is always read as 0.

RMESI Bit

When the RMFDF bit is 1, this bit indicates the ESI bit value of the message stored in the receive buffer. When the RMFDF bit is 0, this bit is always read as 0.

28.4.6.6 RSCFDnCFDRMDFb_q — Receive Buffer Data Field b Register (b = 0 to 4, q = 0 to 31)

Access Size: RSCFDnCFDRMDFb_q register can be read only in 32-bit units
 RSCFDnCFDRMDFb_qL, RSCFDnCFDRMDFb_qH registers can be read only in 16-bit units
 RSCFDnCFDRMDFb_qLL, RSCFDnCFDRMDFb_qLH, RSCFDnCFDRMDFb_qHL, RSCFDnCFDRMDFb_qHH registers can be read only in 8-bit units

Address(es): RSCFDnCFDRMDFb_q: <RSCFDn_base> + H'200C + (H'04 × b) + (H'20 × q)
 RSCFDnCFDRMDFb_qL: <RSCFDn_base> + H'200C + (H'04 × b) + (H'20 × q),
 RSCFDnCFDRMDFb_qH: <RSCFDn_base> + H'200E + (H'04 × b) + (H'20 × q)
 RSCFDnCFDRMDFb_qLL: <RSCFDn_base> + H'200C + (H'04 × b) + (H'20 × q),
 RSCFDnCFDRMDFb_qLH: <RSCFDn_base> + H'200D + (H'04 × b) + (H'20 × q),
 RSCFDnCFDRMDFb_qHL: <RSCFDn_base> + H'200E + (H'04 × b) + (H'20 × q),
 RSCFDnCFDRMDFb_qHH: <RSCFDn_base> + H'200F + (H'04 × b) + (H'20 × q)

Initial Value: H'0000 0000

Bit	31	30	29	28	27	26	25	24	23	22	21	20	19	18	17	16
	RMDB4 × b + 3 [7:0]								RMDB4 × b + 2 [7:0]							
Initial Value	0	0	0	0	0	0	0	0	0	0	0	0	0	0	0	0
R/W	R	R	R	R	R	R	R	R	R	R	R	R	R	R	R	R
Bit	15	14	13	12	11	10	9	8	7	6	5	4	3	2	1	0
	RMDB4 × b + 1 [7:0]								RMDB4 × b + 0 [7:0]							
Initial Value	0	0	0	0	0	0	0	0	0	0	0	0	0	0	0	0
R/W	R	R	R	R	R	R	R	R	R	R	R	R	R	R	R	R

Bit	Bit Name	Initial Value	R/W	Description
31 to 24	RMDB4 × b + 3 [7:0]	All 0	R	Receive Buffer Data Byte 4 × b + 3 Receive Buffer Data Byte 4 × b + 2
23 to 16	RMDB4 × b + 2 [7:0]	All 0	R	Receive Buffer Data Byte 4 × b + 1 Receive Buffer Data Byte 4 × b + 0
15 to 8	RMDB4 × b + 1 [7:0]	All 0	R	Data for a message stored in the receive buffer can be read.
7 to 0	RMDB4 × b + 0 [7:0]	All 0	R	

When the RMDLC[3:0] value in the RSCFDnCFDRMPTRq register is smaller than the payload storage size of the receive buffer, data bytes for which no data is set are read as H'00.

Specify the payload storage size of the receive buffer by the RMPLS[1:0] bits in the RSCFDnCFDRMNB register. Do not read or write the RSCFDnCFDRMDFb_q register corresponding to an area larger than the specified size.

28.4.7 Details of Receive FIFO Buffer-related Registers

28.4.7.1 RSCFDnCFDRFCCx — Receive FIFO Buffer Configuration and Control Register (x = 0 to 7)

Access Size: RSCFDnCFDRFCCx register can be read/written in 32-bit units
 RSCFDnCFDRFCCxL, RSCFDnCFDRFCCxH registers can be read/written in 16-bit units
 RSCFDnCFDRFCCxLL, RSCFDnCFDRFCCxLH, RSCFDnCFDRFCCxHL, RSCFDnCFDRFCCxHH registers can be read/written in 8-bit units

Address(es): RSCFDnCFDRFCCx: <RSCFDn_base> + H'00B8 + (H'04 × x)
 RSCFDnCFDRFCCxL: <RSCFDn_base> + H'00B8 + (H'04 × x),
 RSCFDnCFDRFCCxH: <RSCFDn_base> + H'00BA + (H'04 × x)
 RSCFDnCFDRFCCxLL: <RSCFDn_base> + H'00B8 + (H'04 × x),
 RSCFDnCFDRFCCxLH: <RSCFDn_base> + H'00B9 + (H'04 × x),
 RSCFDnCFDRFCCxHL: <RSCFDn_base> + H'00BA + (H'04 × x),
 RSCFDnCFDRFCCxHH: <RSCFDn_base> + H'00BB + (H'04 × x)

Initial Value: H'0000 0000

Bit	31	30	29	28	27	26	25	24	23	22	21	20	19	18	17	16
	—	—	—	—	—	—	—	—	—	—	—	—	—	—	—	—
Initial Value	0	0	0	0	0	0	0	0	0	0	0	0	0	0	0	0
R/W	R	R	R	R	R	R	R	R	R	R	R	R	R	R	R	R
Bit	15	14	13	12	11	10	9	8	7	6	5	4	3	2	1	0
	RFIGCV[2:0]			RFIM	—	RFDC[2:0]			—	RFPLS[2:0]			—	—	RFIE	RFE
Initial Value	0	0	0	0	0	0	0	0	0	0	0	0	0	0	0	0
R/W	R/W	R/W	R/W	R/W	R	R/W	R/W	R/W	R	R/W	R/W	R/W	R	R	R/W	R/W

Bit	Bit Name	Initial Value	R/W	Description
31 to 16	—	All 0	R	Reserved These bits are read as the value after reset. The write value should be the value after reset.
15 to 13	RFIGCV[2:0]	All 0	R/W	Receive FIFO Interrupt Request Timing Select b15 b14 b13 0 0 0: When FIFO is 1/8 full. 0 0 1: When FIFO is 2/8 full. 0 1 0: When FIFO is 3/8 full. 0 1 1: When FIFO is 4/8 full. 1 0 0: When FIFO is 5/8 full. 1 0 1: When FIFO is 6/8 full. 1 1 0: When FIFO is 7/8 full. 1 1 1: When FIFO is full.
12	RFIM	0	R/W	Receive FIFO Interrupt Source Select 0: An interrupt occurs when the condition set by the RFIGCV[2:0] bits is met. 1: An interrupt occurs each time a message has been received.
11	—	0	R	Reserved This bit is read as the value after reset. The write value should be the value after reset.

Bit	Bit Name	Initial Value	R/W	Description
10 to 8	RFDC[2:0]	All 0	R/W	Receive FIFO Buffer Depth Configuration b10 b9 b8 0 0 0: 0 messages 0 0 1: 4 messages 0 1 0: 8 messages 0 1 1: 16 messages 1 0 0: 32 messages 1 0 1: 48 messages 1 1 0: 64 messages 1 1 1: 128 messages
7	—	0	R	Reserved This bit is read as the value after reset. The write value should be the value after reset.
6 to 4	RFPLS[2:0]	All 0	R/W	Receive FIFO Buffer Payload Storage Size Select b6 b5 b4 0 0 0: 8 bytes 0 0 1: 12 bytes 0 1 0: 16 bytes 0 1 1: 20 bytes 1 0 0: 24 bytes 1 0 1: 32 bytes 1 1 0: 48 bytes 1 1 1: 64 bytes
3, 2	—	All 0	R	Reserved These bits are read as the value after reset. The write value should be the value after reset.
1	RFIE	0	R/W	Receive FIFO Interrupt Enable 0: Receive FIFO interrupt is disabled. 1: Receive FIFO interrupt is enabled.
0	RFE	0	R/W	Receive FIFO Buffer Enable 0: No receive FIFO buffer is used. 1: Receive FIFO buffers are used.

RFICV[2:0] Bits

These bits are used to specify the number of received messages for generating a receive FIFO interrupt request when the RFIM bit is set to 0 with a fraction for the total number of buffers (the setting of RFDC[2:0]).

When the RFDC[2:0] bits are set to 001b (4 messages), set the RFICV[2:0] bits to 001b, 011b, 101b, or 111b. Modify these bits only in global reset mode.

RFIM Bit

This bit is used to select a FIFO interrupt source. Modify this bit only in global reset mode.

RFDC[2:0] Bits

These bits are used to select the number of messages that can be stored in a single receive FIFO buffer. When these bits are set to 000b, no receive FIFO buffer should be used. Modify these bits only in global reset mode.

RFPLS[2:0] Bits

These bits are used to select the maximum payload size that can be stored in the receive FIFO buffer. Modify these bits only in global reset mode.

RFIE Bit

Setting the RFIE bit to 1 enables receive FIFO interrupts. Modify this bit when the RFE bit set to 0 (no receive FIFO buffer is used).

RFE Bit

Setting the RFE bit to 1 makes receive FIFO buffers available. Clearing this bit to 0 sets the RFEMP flag in the RSCFDnCFDRFSTSx register to 1 (buffer empty). Modify this bit in global operating mode or global test mode. Set this bit to 1 with another instruction after the settings to all bits in the RSCFDnCFDRFCCx register have been done. This bit is cleared to 0 in global reset mode.

28.4.7.2 RSCFDnCFDRFSTSx — Receive FIFO Buffer Status Register (x = 0 to 7)

Access Size: RSCFDnCFDRFSTSx register can be read/written in 32-bit units
 RSCFDnCFDRFSTSxL, RSCFDnCFDRFSTSxH registers can be read/written in 16-bit units
 RSCFDnCFDRFSTSxLL, RSCFDnCFDRFSTSxLH, RSCFDnCFDRFSTSxHL, RSCFDnCFDRFSTSxHH registers can be read/written in 8-bit units

Address(es): RSCFDnCFDRFSTSx: <RSCFDn_base> + H'00D8 + (H'04 × x)
 RSCFDnCFDRFSTSxL: <RSCFDn_base> + H'00D8 + (H'04 × x),
 RSCFDnCFDRFSTSxH: <RSCFDn_base> + H'00DA + (H'04 × x)
 RSCFDnCFDRFSTSxLL: <RSCFDn_base> + H'00D8 + (H'04 × x),
 RSCFDnCFDRFSTSxLH: <RSCFDn_base> + H'00D9 + (H'04 × x),
 RSCFDnCFDRFSTSxHL: <RSCFDn_base> + H'00DA + (H'04 × x),
 RSCFDnCFDRFSTSxHH: <RSCFDn_base> + H'00DB + (H'04 × x)

Initial Value: H'0000 0001

Bit	31	30	29	28	27	26	25	24	23	22	21	20	19	18	17	16
	—	—	—	—	—	—	—	—	—	—	—	—	—	—	—	—
Initial Value	0	0	0	0	0	0	0	0	0	0	0	0	0	0	0	0
R/W	R	R	R	R	R	R	R	R	R	R	R	R	R	R	R	R
Bit	15	14	13	12	11	10	9	8	7	6	5	4	3	2	1	0
	RFMC[7:0]								—	—	—	—	RFIF	RFMLT	RFFLL	RFEMP
Initial Value	0	0	0	0	0	0	0	0	0	0	0	0	0	0	0	1
R/W	R	R	R	R	R	R	R	R	R	R	R	R	R/W*1	R/W*1	R	R

Bit	Bit Name	Initial Value	R/W	Description
31 to 16	—	All 0	R	Reserved These bits are read as the value after reset. The write value should be the value after reset.
15 to 8	RFMC[7:0]	All 0	R	Receive FIFO Unread Message Counter The number of unread messages stored in the receive FIFO buffer is displayed.
7 to 4	—	All 0	R	Reserved These bits are read as the value after reset. When writing to these bits, write the value after reset.
3	RFIF	0	R/W*1	Receive FIFO Interrupt Request Flag 0: No receive FIFO interrupt request is present. 1: A receive FIFO interrupt request is present.
2	RFMLT	0	R/W*1	Receive FIFO Message Lost Flag 0: No receive FIFO message is lost. 1: A receive FIFO message is lost.
1	RFFLL	0	R	Receive FIFO Buffer Full Status Flag 0: The receive FIFO buffer is not full. 1: The receive FIFO buffer is full.
0	RFEMP	1	R	Receive FIFO Buffer Empty Status Flag 0: The receive FIFO buffer contains unread message. 1: The receive FIFO buffer contains no unread message (buffer empty).

Note 1. The only effective value for writing to this flag bit is 0, which clears the bit. Otherwise writing to the bit results in retention of its state.

RFMC[7:0] Flag

This flag indicates the number of unread messages in the receive FIFO buffer. This flag becomes H'00 when the RFE bit in the RSCFDnCFDRFCCx register is set to 0.

This flag is H'00 in global reset mode.

RFIF Flag

This flag is set to 1 when the receive FIFO interrupt request generation conditions set by the RFIGCV[2:0] bits and the RFIM bit in the RSCFDnCFDRFCCx register are met. This flag is cleared to 0 in global reset mode or by writing 0 to this flag. Modify this bit in global operating mode or global test mode.

To clear the flags of the register to 0, the program must write 0 to the corresponding flag to be cleared. When writing 0, using store instruction, set the bit to be set to "0" to "0", and the bits not to be set to "0" to "1".

RFMLT Flag

This flag is set to 1 when an attempt is made to store a new message while the receive FIFO buffer is full. In this case, the new message is discarded.

This flag is cleared to 0 in global reset mode or by writing 0 to this flag.

Modify this bit in global operating mode or global test mode.

To clear the flags of the register to 0, the program must write 0 to the corresponding flag to be cleared. When writing 0, using store instruction, set the bit to be set to "0" to "0", and the bits not to be set to "0" to "1".

RFLL Flag

This flag is set to 1 when the number of messages stored in the receive FIFO buffer matches the FIFO buffer depth set by the RFDC[2:0] bits in the RSCFDnCFDRFCCx register.

If the number of messages stored in the receive FIFO buffer becomes smaller than the FIFO buffer depth set by the RFDC[2:0] bits, this flag is cleared to 0. This flag is also cleared to 0 when the RFE bit in the RSCFDnCFDRFCCx register is set to 0 (no receive FIFO buffer is used) or in global reset mode.

RFEMP Flag

This flag is set to 1 when all messages in the receive FIFO buffer have been read. This flag is also set to 1 when the RFE bit in the RSCFDnCFDRFCCx register is 0 or in global reset mode.

This flag is cleared to 0 when even a single received message has been stored in the receive FIFO buffer.

NOTE

To clear the RFMLT or RFIF flag to 0, use a store instruction to write "0" to the given flag and "1" to the other flags.

28.4.7.3 RSCFDnCFDRFPCTR_x — Receive FIFO Buffer Pointer Control Register (x = 0 to 7)

Access Size: RSCFDnCFDRFPCTR_x register can only be written in 32-bit units
 RSCFDnCFDRFPCTR_{xL}, RSCFDnCFDRFPCTR_{xH} registers can only be written in 16-bit units
 RSCFDnCFDRFPCTR_{xLL}, RSCFDnCFDRFPCTR_{xLH}, RSCFDnCFDRFPCTR_{xHL}, RSCFDnCFDRFPCTR_{xHH} registers can only be written in 8-bit units

Address(es): RSCFDnCFDRFPCTR_x: <RSCFDn_base> + H'00F8 + (H'04 × x)
 RSCFDnCFDRFPCTR_{xL}: <RSCFDn_base> + H'00F8 + (H'04 × x),
 RSCFDnCFDRFPCTR_{xH}: <RSCFDn_base> + H'00FA + (H'04 × x)
 RSCFDnCFDRFPCTR_{xLL}: <RSCFDn_base> + H'00F8 + (H'04 × x),
 RSCFDnCFDRFPCTR_{xLH}: <RSCFDn_base> + H'00F9 + (H'04 × x),
 RSCFDnCFDRFPCTR_{xHL}: <RSCFDn_base> + H'00FA + (H'04 × x),
 RSCFDnCFDRFPCTR_{xHH}: <RSCFDn_base> + H'00FB + (H'04 × x)

Initial Value: H'0000 0000

Bit	31	30	29	28	27	26	25	24	23	22	21	20	19	18	17	16
	—	—	—	—	—	—	—	—	—	—	—	—	—	—	—	—
Initial Value	0	0	0	0	0	0	0	0	0	0	0	0	0	0	0	0
R/W	R	R	R	R	R	R	R	R	R	R	R	R	R	R	R	R
Bit	15	14	13	12	11	10	9	8	7	6	5	4	3	2	1	0
	—	—	—	—	—	—	—	—	RFPC[7:0]							
Initial Value	0	0	0	0	0	0	0	0	0	0	0	0	0	0	0	0
R/W	R	R	R	R	R	R	R	R	W	W	W	W	W	W	W	W

Bit	Bit Name	Initial Value	R/W	Description
31 to 8	—	All 0	R	Reserved The write value should be the value after reset.
7 to 0	RFPC[7:0]	All 0	W	Receive FIFO Pointer Control When these bits are set to H'FF, the read pointer moves to the next unread message in the receive FIFO buffer.

When the RFDMAEx value in the RSCFDnCFDCDTCT register is 1 (DMA transfer request enabled), do not write a value to this register.

RFPC[7:0] Bits

When the RFPC[7:0] bits are set to H'FF, the read pointer moves to the next unread message in the receive FIFO buffer. At this time, the RFMC[7:0] (receive FIFO unread message counter) value in the RSCFDnCFDRFSTS_x register is decremented. Read the RSCFDnCFDRFID_x, RSCFDnCFDRFPTR_x, RSCFDnCFDRFDSTS_x, and RSCFDnCFDRFDFd_x registers to read messages in the receive FIFO buffer, and then write H'FF to the RFPC[7:0] bits. When writing H'FF to these bits, make sure that the RFE bit in the RSCFDnCFDRFCC_x register is set to 1 (receive FIFO buffers are used) and the RFEMP flag in the RSCFDnCFDRFSTS_x register is 0 (the receive FIFO buffer contains unread messages).

28.4.7.4 RSCFDnCFDRFIDx — Receive FIFO Buffer Access ID Register (x = 0 to 7)

Access Size: RSCFDnCFDRFIDx register can be read only in 32-bit units
 RSCFDnCFDRFIDxL, RSCFDnCFDRFIDxH registers can be read only in 16-bit units
 RSCFDnCFDRFIDxLL, RSCFDnCFDRFIDxLH, RSCFDnCFDRFIDxHL, RSCFDnCFDRFIDxHH registers can be read only in 8-bit units

Address(es): RSCFDnCFDRFIDx: <RSCFDn_base> + H'3000 + (H'80 × x)
 RSCFDnCFDRFIDxL: <RSCFDn_base> + H'3000 + (H'80 × x),
 RSCFDnCFDRFIDxH: <RSCFDn_base> + H'3002 + (H'80 × x)
 RSCFDnCFDRFIDxLL: <RSCFDn_base> + H'3000 + (H'80 × x),
 RSCFDnCFDRFIDxLH: <RSCFDn_base> + H'3001 + (H'80 × x),
 RSCFDnCFDRFIDxHL: <RSCFDn_base> + H'3002 + (H'80 × x),
 RSCFDnCFDRFIDxHH: <RSCFDn_base> + H'3003 + (H'80 × x)

Initial Value: H'0000 0000

Bit	31	30	29	28	27	26	25	24	23	22	21	20	19	18	17	16
	RFIDE	RFRTR	—	RFID[28:16]												
Initial Value	0	0	0	0	0	0	0	0	0	0	0	0	0	0	0	0
R/W	R	R	R	R	R	R	R	R	R	R	R	R	R	R	R	R
Bit	15	14	13	12	11	10	9	8	7	6	5	4	3	2	1	0
	RFID[15:0]															
Initial Value	0	0	0	0	0	0	0	0	0	0	0	0	0	0	0	0
R/W	R	R	R	R	R	R	R	R	R	R	R	R	R	R	R	R

Bit	Bit Name	Initial Value	R/W	Description
31	RFIDE	0	R	Receive FIFO Buffer IDE 0: Standard ID 1: Extended ID
30	RFRTR	0	R	Receive FIFO Buffer RTR/RRS <ul style="list-style-type: none"> When the received message is a classical CAN frame 0: Data frame 1: Remote frame When the received message is a CANFD frame The RRS bit value of the received message can be read.
29	—	0	R	Reserved This bit is read as the value after reset.
28 to 0	RFID[28:0]	All 0	R	Receive FIFO Buffer ID Data The standard ID or extended ID of received message can be read. Read bits b10 to b0 for standard ID. Bits b28 to b11 are read as 0.

RFIDE Bit

This bit indicates the ID format (standard ID or extended ID) of the message stored in the receive FIFO buffer.

RFRTR Bit

When the received message is a classical CAN frame, this bit indicates the frame format (data frame or remote frame) of the message stored in the receive FIFO buffer. When the received message is a CANFD frame, this bit indicates the RRS bit value in the message.

RFID[28:0] Bits

These bits indicate the ID of the message stored in the receive FIFO buffer.

28.4.7.5 RSCFDnCFDRFPTRx — Receive FIFO Buffer Access Pointer Register (x = 0 to 7)

Access Size: RSCFDnCFDRFPTRx register can be read only in 32-bit units
 RSCFDnCFDRFPTRxL, RSCFDnCFDRFPTRxH registers can be read only in 16-bit units
 RSCFDnCFDRFPTRxLL, RSCFDnCFDRFPTRxLH, RSCFDnCFDRFPTRxHL, RSCFDnCFDRFPTRxHH registers can be read only in 8-bit units

Address(es): RSCFDnCFDRFPTRx: <RSCFDn_base> + H'3004 + (H'80 × x)
 RSCFDnCFDRFPTRxL: <RSCFDn_base> + H'3004 + (H'80 × x),
 RSCFDnCFDRFPTRxH: <RSCFDn_base> + H'3006 + (H'80 × x)
 RSCFDnCFDRFPTRxLL: <RSCFDn_base> + H'3004 + (H'80 × x),
 RSCFDnCFDRFPTRxLH: <RSCFDn_base> + H'3005 + (H'80 × x),
 RSCFDnCFDRFPTRxHL: <RSCFDn_base> + H'3006 + (H'80 × x),
 RSCFDnCFDRFPTRxHH: <RSCFDn_base> + H'3007 + (H'80 × x)

Initial Value: H'0000 0000

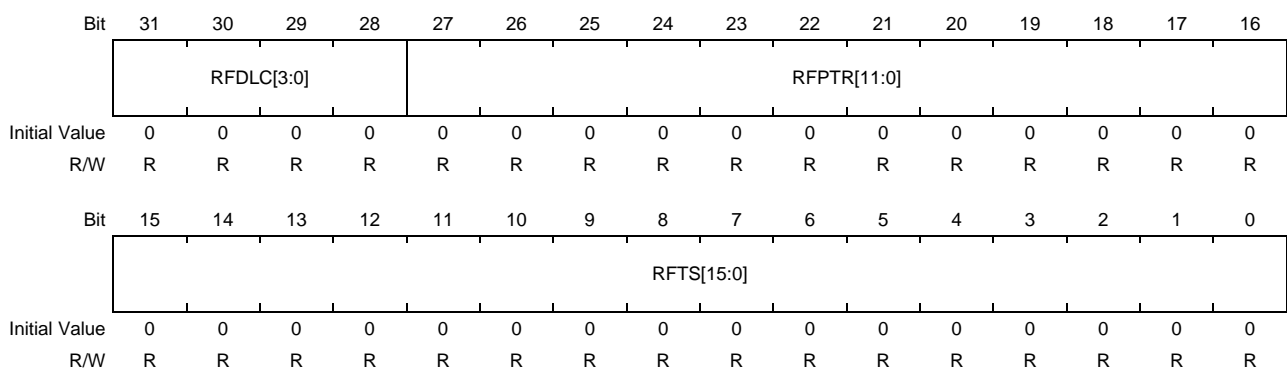

Bit	Bit Name	Initial Value	R/W	Description																																																																																																						
31 to 28	RFDLC[3:0]	All 0	R	Receive FIFO Buffer DLC Data																																																																																																						
				<table border="1"> <thead> <tr> <th>b31</th> <th>b30</th> <th>b29</th> <th>b28</th> <th>Classical CAN Frame</th> <th>CANFD Frame</th> </tr> </thead> <tbody> <tr><td>0</td><td>0</td><td>0</td><td>0</td><td>0 data bytes</td><td></td></tr> <tr><td>0</td><td>0</td><td>0</td><td>1</td><td>1 data byte</td><td></td></tr> <tr><td>0</td><td>0</td><td>1</td><td>0</td><td>2 data bytes</td><td></td></tr> <tr><td>0</td><td>0</td><td>1</td><td>1</td><td>3 data bytes</td><td></td></tr> <tr><td>0</td><td>1</td><td>0</td><td>0</td><td>4 data bytes</td><td></td></tr> <tr><td>0</td><td>1</td><td>0</td><td>1</td><td>5 data bytes</td><td></td></tr> <tr><td>0</td><td>1</td><td>1</td><td>0</td><td>6 data bytes</td><td></td></tr> <tr><td>0</td><td>1</td><td>1</td><td>1</td><td>7 data bytes</td><td></td></tr> <tr><td>1</td><td>0</td><td>0</td><td>0</td><td>8 data bytes</td><td></td></tr> <tr><td>1</td><td>0</td><td>0</td><td>1</td><td>8 data bytes</td><td>12 data bytes</td></tr> <tr><td>1</td><td>0</td><td>1</td><td>0</td><td></td><td>16 data bytes</td></tr> <tr><td>1</td><td>0</td><td>1</td><td>1</td><td></td><td>20 data bytes</td></tr> <tr><td>1</td><td>1</td><td>0</td><td>0</td><td></td><td>24 data bytes</td></tr> <tr><td>1</td><td>1</td><td>0</td><td>1</td><td></td><td>32 data bytes</td></tr> <tr><td>1</td><td>1</td><td>1</td><td>0</td><td></td><td>48 data bytes</td></tr> <tr><td>1</td><td>1</td><td>1</td><td>1</td><td></td><td>64 data bytes</td></tr> </tbody> </table>	b31	b30	b29	b28	Classical CAN Frame	CANFD Frame	0	0	0	0	0 data bytes		0	0	0	1	1 data byte		0	0	1	0	2 data bytes		0	0	1	1	3 data bytes		0	1	0	0	4 data bytes		0	1	0	1	5 data bytes		0	1	1	0	6 data bytes		0	1	1	1	7 data bytes		1	0	0	0	8 data bytes		1	0	0	1	8 data bytes	12 data bytes	1	0	1	0		16 data bytes	1	0	1	1		20 data bytes	1	1	0	0		24 data bytes	1	1	0	1		32 data bytes	1	1	1	0		48 data bytes	1	1	1	1		64 data bytes
b31	b30	b29	b28	Classical CAN Frame	CANFD Frame																																																																																																					
0	0	0	0	0 data bytes																																																																																																						
0	0	0	1	1 data byte																																																																																																						
0	0	1	0	2 data bytes																																																																																																						
0	0	1	1	3 data bytes																																																																																																						
0	1	0	0	4 data bytes																																																																																																						
0	1	0	1	5 data bytes																																																																																																						
0	1	1	0	6 data bytes																																																																																																						
0	1	1	1	7 data bytes																																																																																																						
1	0	0	0	8 data bytes																																																																																																						
1	0	0	1	8 data bytes	12 data bytes																																																																																																					
1	0	1	0		16 data bytes																																																																																																					
1	0	1	1		20 data bytes																																																																																																					
1	1	0	0		24 data bytes																																																																																																					
1	1	0	1		32 data bytes																																																																																																					
1	1	1	0		48 data bytes																																																																																																					
1	1	1	1		64 data bytes																																																																																																					
27 to 16	RFPTR[11:0]	All 0	R	Receive FIFO Buffer Label Data Label information of the received message can be read.																																																																																																						
15 to 0	RFTS[15:0]	All 0	R	Receive FIFO Buffer Timestamp Data Timestamp value of the received message can be read.																																																																																																						

RFDLC[3:0] Bits

These bits contain the data length of the message stored in the receive FIFO buffer.

RFPTR[11:0] Bits

These bits contain the label information of the message stored in the receive FIFO buffer.

RFTS[15:0] Bits

These bits contain the timestamp value of the message stored in the receive FIFO buffer.

28.4.7.6 RSCFDnCFDRFFDSTSx — Receive FIFO CANFD Status Register (x = 0 to 7)

Access Size: RSCFDnCFDRFFDSTSx register can be read only in 32-bit units
RSCFDnCFDRFFDSTSxL, RSCFDnCFDRFFDSTSxH registers can be read only in 16-bit units
RSCFDnCFDRFFDSTSxLL, RSCFDnCFDRFFDSTSxLH, RSCFDnCFDRFFDSTSxHL,
RSCFDnCFDRFFDSTSxHH registers can be read only in 8-bit units

Address(es): RSCFDnCFDRFFDSTSx: <RSCFDn_base> + H'3008 + (H'80 × x)
RSCFDnCFDRFFDSTSxL: <RSCFDn_base> + H'3008 + (H'80 × x),
RSCFDnCFDRFFDSTSxH: <RSCFDn_base> + H'300A + (H'80 × x)
RSCFDnCFDRFFDSTSxLL: <RSCFDn_base> + H'3008 + (H'80 × x),
RSCFDnCFDRFFDSTSxLH: <RSCFDn_base> + H'3009 + (H'80 × x),
RSCFDnCFDRFFDSTSxHL: <RSCFDn_base> + H'300A + (H'80 × x),
RSCFDnCFDRFFDSTSxHH: <RSCFDn_base> + H'300B + (H'80 × x)

Initial Value: H'0000 0000

Bit	31	30	29	28	27	26	25	24	23	22	21	20	19	18	17	16
	—	—	—	—	—	—	—	—	—	—	—	—	—	—	—	—
Initial Value	0	0	0	0	0	0	0	0	0	0	0	0	0	0	0	0
R/W	R	R	R	R	R	R	R	R	R	R	R	R	R	R	R	R
Bit	15	14	13	12	11	10	9	8	7	6	5	4	3	2	1	0
	—	—	—	—	—	—	—	—	—	—	—	—	—	RFFDF	RFBRS	RFESI
Initial Value	0	0	0	0	0	0	0	0	0	0	0	0	0	0	0	0
R/W	R	R	R	R	R	R	R	R	R	R	R	R	R	R	R	R

Bit	Bit Name	Initial Value	R/W	Description
31 to 3	—	All 0	R	Reserved These bits are read as the value after reset.
2	RFFDF	0	R	FDF 0: Classical CAN frame 1: CANFD frame
1	RFBRS	0	R	BRS 0: The bit rate in the data area does not change. 1: The bit rate in the data area changes.
0	RFESI	0	R	ESI 0: Error active node 1: Error passive node

RFFDF Bit

This bit indicates the FD format (classical CAN frame or CANFD frame) of the message stored in the receive FIFO buffer.

RFBRS Bit

When the RFFDF bit is 1, this bit indicates the BRS bit value of the message stored in the receive FIFO buffer. When the RFFDF bit is 0, this bit is always read as 0.

RFESI Bit

When the RFFDF bit is 1, this bit indicates the ESI bit value of the message stored in the receive FIFO buffer. When the RFFDF bit is 0, this bit is always read as 0.

28.4.7.7 RSCFDnCFDRFDFd_x — Receive FIFO Buffer Access Data Field d Register (d = 0 to 15, x = 0 to 7)

Access Size: RSCFDnCFDRFDFd_x register can be read only in 32-bit units
 RSCFDnCFDRFDFd_xL, RSCFDnCFDRFDFd_xH registers can be read only in 16-bit units
 RSCFDnCFDRFDFd_xLL, RSCFDnCFDRFDFd_xLH, RSCFDnCFDRFDFd_xHL, RSCFDnCFDRFDFd_xHH registers can be read only in 8-bit units

Address(es): RSCFDnCFDRFDFd_x: <RSCFDn_base> + H'300C + (H'04 × d) + (H'80 × x)
 RSCFDnCFDRFDFd_xL: <RSCFDn_base> + H'300C + (H'04 × d) + (H'80 × x),
 RSCFDnCFDRFDFd_xH: <RSCFDn_base> + H'300E + (H'04 × d) + (H'80 × x)
 RSCFDnCFDRFDFd_xLL: <RSCFDn_base> + H'300C + (H'04 × d) + (H'80 × x),
 RSCFDnCFDRFDFd_xLH: <RSCFDn_base> + H'300D + (H'04 × d) + (H'80 × x),
 RSCFDnCFDRFDFd_xHL: <RSCFDn_base> + H'300E + (H'04 × d) + (H'80 × x),
 RSCFDnCFDRFDFd_xHH: <RSCFDn_base> + H'300F + (H'04 × d) + (H'80 × x)

Initial Value: H'0000 0000

Bit	31	30	29	28	27	26	25	24	23	22	21	20	19	18	17	16
	RFDB4 × d + 3 [7:0]								RFDB4 × d + 2 [7:0]							
Initial Value	0	0	0	0	0	0	0	0	0	0	0	0	0	0	0	0
R/W	R	R	R	R	R	R	R	R	R	R	R	R	R	R	R	R
Bit	15	14	13	12	11	10	9	8	7	6	5	4	3	2	1	0
	RFDB4 × d + 1 [7:0]								RFDB4 × d + 0 [7:0]							
Initial Value	0	0	0	0	0	0	0	0	0	0	0	0	0	0	0	0
R/W	R	R	R	R	R	R	R	R	R	R	R	R	R	R	R	R

Bit	Bit Name	Initial Value	R/W	Description
31 to 24	RFDB4 × d + 3 [7:0]	All 0	R	Receive Buffer Data Byte 4 × d + 3 Receive Buffer Data Byte 4 × d + 2
23 to 16	RFDB4 × d + 2 [7:0]	All 0	R	Receive Buffer Data Byte 4 × d + 1 Receive Buffer Data Byte 4 × d + 0
15 to 8	RFDB4 × d + 1 [7:0]	All 0	R	Data for a message stored in the receive buffer can be read.
7 to 0	RFDB4 × d + 0 [7:0]	All 0	R	

When the RFDLC[3:0] value in the RSCFDnCFDRFPTRx register is smaller than the payload storage size of the receive FIFO buffer, data bytes for which no data is set are read as H'00.

Specify the payload storage size of the receive FIFO buffer by the RFPLS[2:0] bits in the RSCFDnCFDRFCCx register.

Do not read or write the RSCFDnCFDRFDFd_x register corresponding to an area larger than the specified size.

28.4.8 Transmit/Receive FIFO Buffer-related Registers

28.4.8.1 RSCFDnCFDCFCCK — Transmit/receive FIFO Buffer Configuration and Control Register k (k = 0 to 5)

Access Size: RSCFDnCFDCFCCK register can be read/written in 32-bit units
 RSCFDnCFDCFCCKL, RSCFDnCFDCFCCKH registers can be read/written in 16-bit units
 RSCFDnCFDCFCCKLL, RSCFDnCFDCFCCKLH, RSCFDnCFDCFCCKHL, RSCFDnCFDCFCCKHH registers can be read/written in 8-bit units

Address(es): RSCFDnCFDCFCCK: <RSCFDn_base> + H'0118 + (H'04 × k)
 RSCFDnCFDCFCCKL: <RSCFDn_base> + H'0118 + (H'04 × k),
 RSCFDnCFDCFCCKH: <RSCFDn_base> + H'011A + (H'04 × k)
 RSCFDnCFDCFCCKLL: <RSCFDn_base> + H'0118 + (H'04 × k),
 RSCFDnCFDCFCCKLH: <RSCFDn_base> + H'0119 + (H'04 × k),
 RSCFDnCFDCFCCKHL: <RSCFDn_base> + H'011A + (H'04 × k),
 RSCFDnCFDCFCCKHH: <RSCFDn_base> + H'011B + (H'04 × k)

Initial Value: H'0000 0000

Bit	31	30	29	28	27	26	25	24	23	22	21	20	19	18	17	16
	CFITT[7:0]							CFTML[3:0]			CFITR	CFITSS	CFM[1:0]			
Initial Value	0	0	0	0	0	0	0	0	0	0	0	0	0	0	0	0
R/W	R/W	R/W	R/W	R/W	R/W	R/W	R/W	R/W	R/W	R/W	R/W	R/W	R/W	R/W	R/W	R/W
Bit	15	14	13	12	11	10	9	8	7	6	5	4	3	2	1	0
	CFIGCV[2:0]		CFIM	—	CFDC[2:0]		—	CFPLS[2:0]		—	CFTXIE	CFRXIE	CFE			
Initial Value	0	0	0	0	0	0	0	0	0	0	0	0	0	0	0	0
R/W	R/W	R/W	R/W	R/W	R	R/W	R/W	R/W	R	R/W	R/W	R/W	R	R/W	R/W	R/W

Bit	Bit Name	Initial Value	R/W	Description
31 to 24	CFITT[7:0]	All 0	R/W	Set a message transmission interval. Set Value: H'00 to H'FF
23 to 20	CFTML[3:0]	All 0	R/W	Transmit Buffer Link Configuration Set the transmit buffer number to be linked to the transmit/receive FIFO buffer.
19	CFITR	0	R/W	Transmit/Receive FIFO Interval Timer Resolution 0: Clock dividing pclk by (ITRCP[15:0] bits) 1: Clock dividing pclk by (ITRCP[15:0] bits × 10)
18	CFITSS	0	R/W	Transmit/Receive FIFO Interval Timer Clock Source Select 0: Interval timer clock source selected by the CFITR bit 1: Interval timer clock source is the nominal bit time clock for the channel to which the FIFO is linked.
17 to 16	CFM[1:0]	All 0	R/W	Transmit/Receive FIFO Mode Select b17 b16 0 0: Receive mode 0 1: Transmit mode 1 0: Gateway mode 1 1: Setting prohibited

Bit	Bit Name	Initial Value	R/W	Description
15 to 13	CFIGCV[2:0]	All 0	R/W	Transmit/Receive FIFO Receive Interrupt Request Timing Select b15 b14 b13 0 0 0: When FIFO is 1/8 full. 0 0 1: When FIFO is 2/8 full. 0 1 0: When FIFO is 3/8 full. 0 1 1: When FIFO is 4/8 full. 1 0 0: When FIFO is 5/8 full. 1 0 1: When FIFO is 6/8 full. 1 1 0: When FIFO is 7/8 full. 1 1 1: When FIFO is full.
12	CFIM	0	R/W	Transmit/Receive FIFO Interrupt Source Select 0: <ul style="list-style-type: none"> Receive mode/gateway mode When the number of received messages has met the condition set by the CFIGCV[2:0] bits, a FIFO receive interrupt request is generated. Transmit mode/gateway mode When the buffer becomes empty upon completion of message transmission, a FIFO transmit interrupt request is generated. 1: <ul style="list-style-type: none"> Receive mode/gateway mode A FIFO receive interrupt request is generated each time a message has been received. Transmit mode/gateway mode A FIFO transmit interrupt request is generated each time a message has been transmitted.
11	—	0	R	Reserved This bit is read as the value after reset. The write value should be the value after reset.
10 to 8	CFDC[2:0]	All 0	R/W	Transmit/Receive FIFO Buffer Depth Configuration b10 b9 b8 0 0 0: 0 messages 0 0 1: 4 messages 0 1 0: 8 messages 0 1 1: 16 messages 1 0 0: 32 messages 1 0 1: 48 messages 1 1 0: 64 messages 1 1 1: 128 messages
7	—	0	R	Reserved This bit is read as the value after reset. The write value should be the value after reset.
6 to 4	CFPLS[2:0]	All 0	R/W	Transmit/Receive FIFO Buffer Payload Storage Size Select b6 b5 b4 0 0 0: 8 bytes 0 0 1: 12 bytes 0 1 0: 16 bytes 0 1 1: 20 bytes 1 0 0: 24 bytes 1 0 1: 32 bytes 1 1 0: 48 bytes 1 1 1: 64 bytes
3	—	0	R	Reserved This bit is read as the value after reset. The write value should be the value after reset.

Bit	Bit Name	Initial Value	R/W	Description
2	CFTXIE	0	R/W	Transmit/Receive FIFO Transmit Interrupt Enable 0: Transmit/receive FIFO transmit interrupt is disabled. 1: Transmit/receive FIFO transmit interrupt is enabled.
1	CFRXIE	0	R/W	Transmit/Receive FIFO Receive Interrupt Enable 0: Transmit/receive FIFO receive interrupt is disabled. 1: Transmit/receive FIFO receive interrupt is enabled.
0	CFE	0	R/W	Transmit/Receive FIFO Buffer Enable 0: No transmit/receive FIFO buffer is used. 1: Transmit/receive FIFO buffers are used.

CFITT[7:0] Bits

These bits are used to set a message transmission interval when transmitting messages continuously from a transmit/receive FIFO buffer whose CFM[1:0] bits are set to 01b (transmit mode) or 10b (gateway mode).

Clear the CFE bit to 0 (no transmit/receive FIFO buffer is used) before modifying the CFITT[7:0] bits.

CFTML[3:0] Bits

These bits are used to set the number of transmit buffer on the channel which will be linked to transmit/receive FIFO buffer k when the CFM[1:0] bits are set to 01b (transmit mode) or 10b (gateway mode). There are three transmit/receive FIFO buffers per channel, so channel number m of FIFO buffer k is calculated as $m = k/3$ (integer division). The actual assigned transmit buffer number p linked to FIFO buffer k will be $((16 \times m) + CFTML[3:0])$.

See **Table 28.11** and **Table 28.12**, as for the relationship between transmit/receive FIFO buffer k and transmit buffer p. Setting the CFDC[2:0] bits to 001b or more enables the setting of the CFTML[3:0] bits.

Do not link to any transmit buffer which is already allocated to a transmit queue on the identical channel or to another transmit/receive FIFO buffer. Modify these bits only in global reset mode.

CFITR Bit

This bit is enabled when the CFITSS bit is 0.

When this bit is 0, the interval timer clock source is the pclk/2 clock divided by the value of the ITRCP[15:0] bits in the RSCFDnCFDGCFCFG register.

When this bit is 1, the interval timer clock source is the pclk/2 clock divided by (the value of the ITRCP[15:0] bits in the RSCFDnCFDGCFCFG register $\times 10$).

Modify this bit while the CFE bit is set to 0 (no transmit/receive FIFO buffer is used).

CFITSS Bit

When this bit is 0, the clock selected by the CFITR bit is the count source of the interval timer.

When this bit is 1, the nominal bit time clock of the channel to which the FIFO is linked is the count source of the interval timer. Use this count source only for the channel that does not handle the CANFD frames.

Modify this bit while the CFE bit is set to 0 (no transmit/receive FIFO buffer is used).

CFM[1:0] Bits

These bits are used to select transmit/receive FIFO mode. Modify these bits only in global reset mode.

CFIGCV[2:0] Bits

These bits are used to specify the number of received messages for generating a transmit/receive FIFO receive interrupt request when the CFM[1:0] bits are set to 00b (receive mode) or 10b (gateway mode) and the CFIM bit is set to 0 with a fraction for the total number of buffers (the setting of CFDC[2:0]).

When the CFDC[2:0] bits are set to 001b (4 messages), set the CFIGCV[2:0] bits to 001b, 011b, 101b, or 111b.

Modify these bits only in global reset mode.

CFIM Bit

This bit is used to select a transmit/receive FIFO interrupt source. Modify this bit only in global reset mode.

CFDC[2:0] Bits

These bits are used to set the number of messages that can be stored in a single transmit/receive FIFO buffer. When these bits are set to 000b, do not use a transmit/receive FIFO buffer. Modify these bits only in global reset mode.

CFPLS[2:0] Bits

These bits are used to select the maximum payload size that can be stored in the transmit/receive FIFO buffer. Modify these bits only in global reset mode.

CFTXIE Bit

When this bit is set to 1 and the CFTXIF flag in the RSCFDnCFDCFSTSk register is set to 1, a transmit/receive FIFO transmit interrupt request is generated.

Modify this bit with the CFE bit set to 0 (no transmit/receive FIFO buffer is used).

CFRXIE Bit

When this bit is set to 1 and the CFRXIF flag in the RSCFDnCFDCFSTSk register is set to 1, a transmit/receive FIFO receive interrupt request is generated.

Modify this bit with the CFE bit set to 0.

CFE Bit

Setting this bit to 1 makes transmit/receive FIFO buffers available.

When this bit is set to 0 in transmit mode or gateway mode, if a message in the transmit/receive FIFO buffer is being transmitted or will be transmitted next, the transmit/receive FIFO buffer becomes empty after completion of transmission of that message, or upon detection of a CAN bus error, or arbitration-lost. In other cases or in receive mode, the transmit/ receive FIFO buffer becomes empty immediately.

This bit is cleared to 0 when the following conditions are met.

- Receive mode: Global reset mode
- Transmit mode or gateway mode: Channel reset mode

Modify this bit in the following mode.

- Receive mode: Global operating mode or global test mode
- Transmit mode or gateway mode: Channel communication mode or channel halt mode

After all other bits in the RSCFDnCFDCFCCk register have been set, set this bit to 1 by using another instruction.

28.4.8.2 RSCFDnCFDCFSTSk — Transmit/receive FIFO Buffer Status Register (k = 0 to 5)

Access Size: RSCFDnCFDCFSTSk register can be read/written in 32-bit units
 RSCFDnCFDCFSTSkL, RSCFDnCFDCFSTSkH registers can be read/written in 16-bit units
 RSCFDnCFDCFSTSkLL, RSCFDnCFDCFSTSkLH, RSCFDnCFDCFSTSkHL, RSCFDnCFDCFSTSkHH registers can be read/written in 8-bit units

Address(es): RSCFDnCFDCFSTSk: <RSCFDn_base> + H'0178 + (H'04 × k)
 RSCFDnCFDCFSTSkL: <RSCFDn_base> + H'0178 + (H'04 × k),
 RSCFDnCFDCFSTSkH: <RSCFDn_base> + H'017A + (H'04 × k)
 RSCFDnCFDCFSTSkLL: <RSCFDn_base> + H'0178 + (H'04 × k),
 RSCFDnCFDCFSTSkLH: <RSCFDn_base> + H'0179 + (H'04 × k),
 RSCFDnCFDCFSTSkHL: <RSCFDn_base> + H'017A + (H'04 × k),
 RSCFDnCFDCFSTSkHH: <RSCFDn_base> + H'017B + (H'04 × k)

Initial Value: H'0000 0001

Bit	31	30	29	28	27	26	25	24	23	22	21	20	19	18	17	16
	—	—	—	—	—	—	—	—	—	—	—	—	—	—	—	—
Initial Value	0	0	0	0	0	0	0	0	0	0	0	0	0	0	0	0
R/W	R	R	R	R	R	R	R	R	R	R	R	R	R	R	R	R
Bit	15	14	13	12	11	10	9	8	7	6	5	4	3	2	1	0
	CFMC[7:0]							—	—	—	CFTXIF	CFRXIF	CFMLT	CFLL	CFEMP	
Initial Value	0	0	0	0	0	0	0	0	0	0	0	0	0	0	0	0
R/W	R	R	R	R	R	R	R	R	R	R	R	R/W*1	R/W*1	R/W*1	R	R

Bit	Bit Name	Initial Value	R/W	Description
31 to 16	—	All 0	R	Reserved These bits are read as the value after reset. The write value should be the value after reset.
15 to 8	CFMC[7:0]	All 0	R	Transmit/Receive FIFO Message Counter The number of messages stored in the transmit/receive FIFO buffer.
7 to 5	—	All 0	R	Reserved These bits are read as the value after reset. When writing to these bits, write the value after reset.
4	CFTXIF	0	R/W*1	Transmit/Receive FIFO Transmit Interrupt Request Flag 0: No transmit/receive FIFO transmit interrupt request is present. 1: A transmit/receive FIFO transmit interrupt request is present.
3	CFRXIF	0	R/W*1	Transmit/Receive FIFO Receive Interrupt Request Flag 0: No transmit/receive FIFO receive interrupt request is present. 1: A transmit/receive FIFO receive interrupt request is present.
2	CFMLT	0	R/W*1	Transmit/Receive FIFO Message Lost Flag 0: No transmit/receive FIFO message is lost. 1: A transmit/receive FIFO message is lost.
1	CFLL	0	R	Transmit/Receive FIFO Buffer Full Status Flag 0: The transmit/receive FIFO buffer is not full. 1: The transmit/receive FIFO buffer is full.
0	CFEMP	0	R	Transmit/Receive FIFO Buffer Empty Status Flag 0: The transmit/receive FIFO buffer contains messages. 1: The transmit/receive FIFO buffer contains no message (buffer empty).

Note 1. The only effective value for writing to this flag bit is 0, which clears the bit. Otherwise writing to the bit results in retention of its state.

CFMC[7:0] Bits

The CFMC[7:0] bits indicate the following values that depend on the setting of the CFM[1:0] bits in the RSCFDnCFDCFCCK register.

- When CFM[1:0] value is 01b (transmit mode): Number of untransmitted messages in the buffer
- When CFM[1:0] value is 00b (receive mode): Number of unread received messages in the buffer
- When CFM[1:0] value is 10b (gateway mode): Number of untransmitted received messages in the buffer

These bits are cleared to 0 when any of the following conditions is met.

- When CFM[1:0] value is 00b: In global reset mode
- When CFM[1:0] value is 01b or 10b: In channel reset mode
- When the CFE bit in the RSCFDnCFDCFCCK register is cleared to 0.

CFTXIF Flag

The CFTXIF flag is set to 1 when any of the following conditions is met.

- When the CFM[1:0] bits are set to 01b or 10b, and the factor selected by the CFIM bit in the RSCFDnCFDCFCCK register occurs

The CFTXIF flag is cleared to 0 when any of the following conditions is met.

- When 0 is written to the CFTXIF flag
- When the CFM[1:0] bits are set to 00b: In global reset mode
- When the CFM[1:0] bits are set to 01b or 10b: In channel reset mode

Write 0 to this flag in global operating mode or global test mode.

To clear the flags of the register to 0, the program must write 0 to the corresponding flag to be cleared. When writing 0, using store instruction, set the bit to be set to “0” to “0”, and the bits not to be set to “0” to “1”.

CFRXIF Flag

The CFRXIF flag is set to 1 when any of the following conditions is met.

- When the CFM[1:0] bits are set to 00b or 10b, and the factor selected by the CFIM bit in the RSCFDnCFDCFCCK register occurs

The CFRXIF flag is cleared to 0 when any of the following conditions is met.

- When 0 is written to the CFRXIF flag
- When the CFM[1:0] bits are set to 00b: In global reset mode
- When the CFM[1:0] bits are set to 01b or 10b: In channel reset mode

Write 0 to this flag in global operating mode or global test mode.

To clear the flags of the register to 0, the program must write 0 to the corresponding flag to be cleared. When writing 0, using store instruction, set the bit to be set to “0” to “0”, and the bits not to be set to “0” to “1”.

CFMLT Flag

The CFMLT flag is set to 1 when any of the following conditions is met.

- When an attempt is made to store a new message while the transmit/receive FIFO buffer is full. In this case, the new message is discarded.

The CFMLT flag is cleared to 0 when any of the following conditions is met.

- When 0 is written to the CFMLT flag
- When the CFM[1:0] bits are set to 00b: In global reset mode
- When the CFM[1:0] bits are set to 01b or 10b: In channel reset mode

Write 0 to this flag in global operating mode or global test mode

To clear the flags of the register to 0, the program must write 0 to the corresponding flag to be cleared. When writing 0, using store instruction, set the bit to be set to “0” to “0”, and the bits not to be set to “0” to “1”.

CFLL Flag

The CFLL flag is set to 1 when any of the following conditions is met.

- When the number of messages stored in the transmit/receive FIFO buffer matches the FIFO buffer depth set by the CFDC[2:0] bits in the RSCFDnCFDCFCCK register.

The CFMLT flag is cleared to 0 when any of the following conditions is met.

- When the number of messages stored in the transmit/receive FIFO buffer becomes smaller than the FIFO buffer depth set by the CFDC[2:0] bits.
- When the CFE bit in the RSCFDnCFDCFCCK register is 0 (no transmit/receive FIFO buffer is used): When not in the transmit abort
- When the CFM[1:0] bits are set to 00b: In global reset mode
- When the CFM[1:0] bits are set to 01b or 10b: In channel reset mode

CFEMP Flag

The CFEMP flag is set to 1 when any of the following conditions is met.

- When the CFM[1:0] bits are set to 00b: All messages have been read, or in global reset mode
- When the CFM[1:0] bits are set to 01b or 10b: All messages have been transmitted, or in channel reset mode
- When the CFE bit is 0 (no transmit/receive FIFO buffer is used): Not in the transmit abort

The CFEMP flag is cleared to 0 when any of the following conditions is met.

- When the CFM[1:0] bits are set to 00b or 10b: At least one received message has been stored in the transmit/receive FIFO buffer.
- When the CFM[1:0] bits are set to 01b: A value of H'FF has been written to the RSCFDnCFDCFPCTRk register after data was written to the RSCFDnCFDCFDK, RSCFDnCFDCFPTRk, RSCFDnCFDCFFDCSTSk, and RSCFDnCFDCFDf_k registers.

NOTE

To clear CFTXIF, CFRXIF, or CFMLT flag to 0, the program must write 0. When writing, use a store instruction to write “0” to the given flag and “1” to other flags.

28.4.8.3 RSCFDnCFDCFPCTRk — Transmit/receive FIFO Buffer Pointer Control Register (k = 0 to 5)

Access Size: RSCFDnCFDCFPCTRk register can only be written in 32-bit units
 RSCFDnCFDCFPCTRkL, RSCFDnCFDCFPCTRkH registers can only be written in 16-bit units
 RSCFDnCFDCFPCTRkLL, RSCFDnCFDCFPCTRkLH, RSCFDnCFDCFPCTRkHL, RSCFDnCFDCFPCTRkHH registers can only be written in 8-bit units

Address(es): RSCFDnCFDCFPCTRk: <RSCFDn_base> + H'01D8 + (H'04 × k)
 RSCFDnCFDCFPCTRkL: <RSCFDn_base> + H'01D8 + (H'04 × k),
 RSCFDnCFDCFPCTRkH: <RSCFDn_base> + H'01DA + (H'04 × k)
 RSCFDnCFDCFPCTRkLL: <RSCFDn_base> + H'01D8 + (H'04 × k),
 RSCFDnCFDCFPCTRkLH: <RSCFDn_base> + H'01D9 + (H'04 × k),
 RSCFDnCFDCFPCTRkHL: <RSCFDn_base> + H'01DA + (H'04 × k),
 RSCFDnCFDCFPCTRkHH: <RSCFDn_base> + H'01DB + (H'04 × k)

Initial Value: H'0000 0000

Bit	31	30	29	28	27	26	25	24	23	22	21	20	19	18	17	16
	—	—	—	—	—	—	—	—	—	—	—	—	—	—	—	—
Initial Value	0	0	0	0	0	0	0	0	0	0	0	0	0	0	0	0
R/W	R	R	R	R	R	R	R	R	R	R	R	R	R	R	R	R
Bit	15	14	13	12	11	10	9	8	7	6	5	4	3	2	1	0
	—	—	—	—	—	—	—	—	CFPC[7:0]							
Initial Value	0	0	0	0	0	0	0	0	0	0	0	0	0	0	0	0
R/W	R	R	R	R	R	R	R	R	W	W	W	W	W	W	W	W

Bit	Bit Name	Initial Value	R/W	Description
31 to 8	—	All 0	R	Reserved The write value should be the value after reset.
7 to 0	CFPC[7:0]	All 0	W	Transmit/Receive FIFO Pointer Control <ul style="list-style-type: none"> • Receive mode: Writing H'FF to these bits moves the read pointer to the next unread message in the transmit/receive FIFO buffer. • Transmit mode: Writing H'FF to these bits moves the write pointer to the next stage of the transmit/receive FIFO buffer. • Gateway mode: Setting prohibited

When the corresponding transmit/receive FIFO buffer is the first transmit/receive FIFO buffer ($k = 3 \times m$) allocated to channel m and when the CFDMAEm bit in the RSCFDnCFDCDTCT register is 1 (DMA transfer request enabled), do not write a value to this register.

CFPC[7:0] Bits

- Receive mode (CFM[1:0] value in the RSCFDnCFDCFCCK register is 00b):
Writing H'FF to the CFPC[7:0] bits moves the read pointer to the next unread message in the transmit/receive FIFO buffer. At this time, the CFMC[7:0] value (transmit/receive FIFO message counter) in the RSCFDnCFDCFSTSk register is decremented. Read the RSCFDnCFDCFIDk, RSCFDnCFDCFPTRk, RSCFDnCFDCFFDCSTSk, and RSCFDnCFDCFDf_k registers to read messages from the transmit/receive FIFO buffer, and then write H'FF to the CFPC[7:0] bits.
When writing H'FF to these bits, make sure that the CFE bit in the RSCFDnCFDCFCCK register is set to 1 (transmit/receive FIFO buffers are used) and the CFEMP flag in the RSCFDnCFDCFSTSk register is 0 (the transmit/receive FIFO buffer contains messages).
- Transmit mode (CFM[1:0] value in the RSCFDnCFDCFCCK register is 01b):
Writing H'FF to the CFPC[7:0] bits stores the data written to the RSCFDnCFDCFIDk, RSCFDnCFDCFPTRk, RSCFDnCFDCFFDCSTSk, and RSCFDnCFDCFDf_k registers in the transmit/receive FIFO buffer and moves the write pointer to the next stage of the transmit/receive FIFO buffer. At this time, the CFMC[7:0] value is incremented. Write transmit messages to the RSCFDnCFDCFIDk, RSCFDnCFDCFPTRk, RSCFDnCFDCFFDCSTSk, and RSCFDnCFDCFDf_k registers before writing H'FF to the CFPC[7:0] bits.
When writing H'FF to these bits, make sure that the CFE bit in the RSCFDnCFDCFCCK register is set to 1 and the CFFLL flag in the RSCFDnCFDCFSTSk register is 0 (the transmit/receive FIFO buffer is not full).
- Gateway mode (CFM[1:0] value in the RSCFDnCFDCFCCK register is 10b):
Setting prohibited

28.4.8.4 RSCFDnCFDCFDk — Transmit/receive FIFO Buffer Access ID Register (k = 0 to 5)

Access Size: RSCFDnCFDCFDk register can be read/written in 32-bit units
 RSCFDnCFDCFDkL, RSCFDnCFDCFDkH registers can be read/written in 16-bit units
 RSCFDnCFDCFDkLL, RSCFDnCFDCFDkLH, RSCFDnCFDCFDkHL, RSCFDnCFDCFDkHH registers can be read/written in 8-bit units

Address(es): RSCFDnCFDCFDk: <RSCFDn_base> + H'3400 + (H'80 × k)
 RSCFDnCFDCFDkL: <RSCFDn_base> + H'3400 + (H'80 × k),
 RSCFDnCFDCFDkH: <RSCFDn_base> + H'3402 + (H'80 × k)
 RSCFDnCFDCFDkLL: <RSCFDn_base> + H'3400 + (H'80 × k),
 RSCFDnCFDCFDkLH: <RSCFDn_base> + H'3401 + (H'80 × k),
 RSCFDnCFDCFDkHL: <RSCFDn_base> + H'3402 + (H'80 × k),
 RSCFDnCFDCFDkHH: <RSCFDn_base> + H'3403 + (H'80 × k)

Initial Value: H'0000 0000

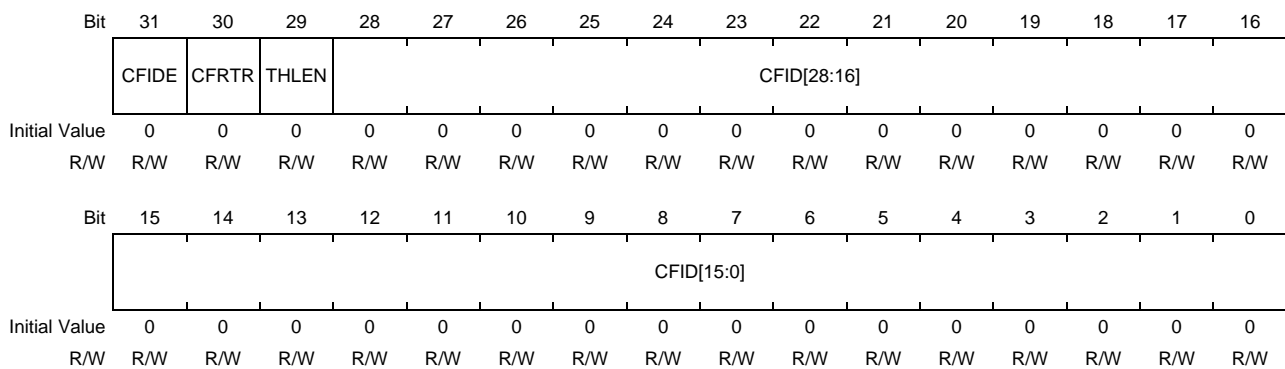

Bit	Bit Name	Initial Value	R/W	Description
31	CFIDE	0	R/W	Transmit/Receive FIFO Buffer IDE 0: Standard ID 1: Extended ID
30	CFRTR	0	R/W	Transmit/Receive FIFO Buffer RTR/RRS <ul style="list-style-type: none"> When the CFM[1:0] value is 01b (transmit mode) <ul style="list-style-type: none"> When the transmit message is a classical CAN frame <ul style="list-style-type: none"> 0: Data frame 1: Remote frame When the transmit message is a CANFD frame Write 0 to this bit. When the CFM[1:0] value is 00b (receive mode) <ul style="list-style-type: none"> When the received message is a classical CAN frame <ul style="list-style-type: none"> 0: Data frame 1: Remote frame When the received message is a CANFD frame The RRS bit value of the received message can be read.
29	THLEN	0	R/W	Transmit History Data Store Enable This bit is valid only when the CFM[1:0] value is 01b (transmit mode). 0: Transmit history data is not stored in the buffer. 1: Transmit history data is stored in the buffer.

Bit	Bit Name	Initial Value	R/W	Description
28 to 0	CFID[28:0]	All 0	R/W	Transmit/Receive FIFO Buffer ID Data <ul style="list-style-type: none"> When CFM[1:0] value is 01b (transmit mode): Set standard ID or extended ID. For standard ID, write an ID to bits 10 to 0 and write 0 to bits 28 to 11. When CFM[1:0] value is 00b (receive mode): Standard ID or extended ID in the received message can be read. For standard ID, read bits 10 to 0. Bits 28 to 11 are read as 0.

This register is writable only when the CFM[1:0] value in the RSCFDnCFDCFCCK register is 01b (transmit mode). This register is readable only when the CFM[1:0] value is 00b (receive mode). This RSCFDnCFDCFIDk register should not be read or written when the CFM[1:0] value is 10b (gateway mode).

CFIDE Bit

This bit indicates the ID format (standard ID or extended ID) of the received message stored in the transmit/receive FIFO buffer when the CFM[1:0] value is 00b. When the CFM[1:0] value is 01b, this bit is used to set the ID format of the message to be transmitted from the transmit/receive FIFO buffer.

CFRTR Bit

If the received message is a classical CAN frame, this bit indicates the data format (data frame or remote frame) of the received message stored in the transmit/receive FIFO buffer when the CFM[1:0] value is 00b. If the received message is a CANFD frame, this bit indicates the RRS bit value of the received message.

When the CFM[1:0] value is 01b, this bit is used to set the data format of the message to be transmitted from the transmit/receive FIFO buffer.

When the CFFDF bit in the RSCFDnCFDCFFDCSTSk register is 1 (CANFD frame), set this bit to 0.

THLEN Bit

When this bit is set to 1, the transmit history data (label information, buffer number, buffer type, and timestamp) of transmit messages is stored in the transmit history buffer after transmission is completed.

This bit is enabled when the CFM[1:0] value is 01b (transmit mode).

CFID[28:0] Bits

These bits contain the ID of the received message stored in the transmit/receive FIFO buffer when the CFM[1:0] value is 00b.

When the CFM[1:0] value is 01b, this bit is used to set the ID of the message to be transmitted from the transmit/receive FIFO buffer.

28.4.8.5 RSCFDnCFDCFPTRk — Transmit/receive FIFO Buffer Access Pointer Register (k = 0 to 5)

Access Size: RSCFDnCFDCFPTRk register can be read/written in 32-bit units
 RSCFDnCFDCFPTRkL, RSCFDnCFDCFPTRkH registers can be read/written in 16-bit units
 RSCFDnCFDCFPTRkLL, RSCFDnCFDCFPTRkLH, RSCFDnCFDCFPTRkHL, RSCFDnCFDCFPTRkHH registers can be read/written in 8-bit units

Address(es): RSCFDnCFDCFPTRk: <RSCFDn_base> + H'3404 + (H'80 × k)
 RSCFDnCFDCFPTRkL: <RSCFDn_base> + H'3404 + (H'80 × k),
 RSCFDnCFDCFPTRkH: <RSCFDn_base> + H'3406 + (H'80 × k)
 RSCFDnCFDCFPTRkLL: <RSCFDn_base> + H'3404 + (H'80 × k),
 RSCFDnCFDCFPTRkLH: <RSCFDn_base> + H'3405 + (H'80 × k),
 RSCFDnCFDCFPTRkHL: <RSCFDn_base> + H'3406 + (H'80 × k),
 RSCFDnCFDCFPTRkHH: <RSCFDn_base> + H'3407 + (H'80 × k)

Initial Value: H'0000 0000

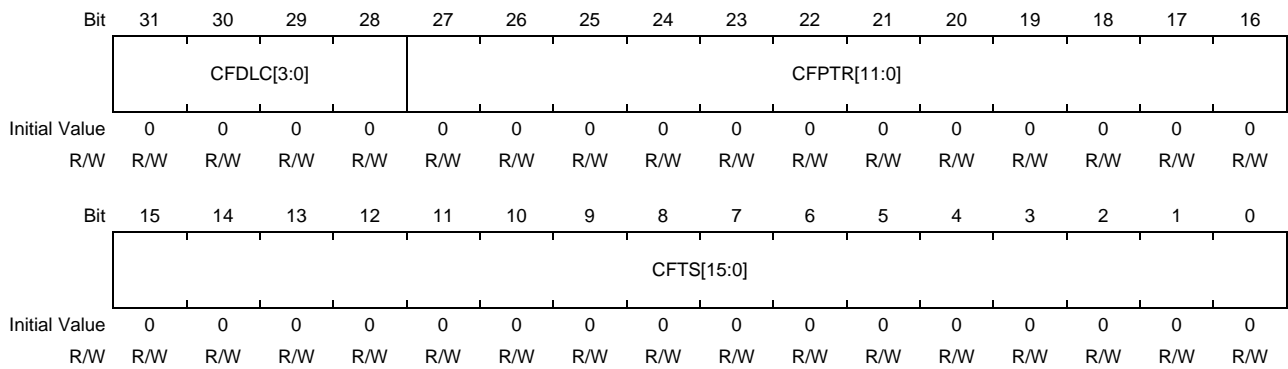

Bit	Bit Name	Initial Value	R/W	Description																																																																																																						
30 to 28	CFDL3:0	All 0	R/W	Transmit/Receive FIFO Buffer DLC Data																																																																																																						
				<table border="1"> <thead> <tr> <th>b31</th> <th>b30</th> <th>b29</th> <th>b28</th> <th>Classical CAN Frame</th> <th>CANFD Frame</th> </tr> </thead> <tbody> <tr> <td>0</td> <td>0</td> <td>0</td> <td>0</td> <td>0 data bytes</td> <td></td> </tr> <tr> <td>0</td> <td>0</td> <td>0</td> <td>1</td> <td>1 data byte</td> <td></td> </tr> <tr> <td>0</td> <td>0</td> <td>1</td> <td>0</td> <td>2 data bytes</td> <td></td> </tr> <tr> <td>0</td> <td>0</td> <td>1</td> <td>1</td> <td>3 data bytes</td> <td></td> </tr> <tr> <td>0</td> <td>1</td> <td>0</td> <td>0</td> <td>4 data bytes</td> <td></td> </tr> <tr> <td>0</td> <td>1</td> <td>0</td> <td>1</td> <td>5 data bytes</td> <td></td> </tr> <tr> <td>0</td> <td>1</td> <td>1</td> <td>0</td> <td>6 data bytes</td> <td></td> </tr> <tr> <td>0</td> <td>1</td> <td>1</td> <td>1</td> <td>7 data bytes</td> <td></td> </tr> <tr> <td>1</td> <td>0</td> <td>0</td> <td>0</td> <td>8 data bytes</td> <td></td> </tr> <tr> <td>1</td> <td>0</td> <td>0</td> <td>1</td> <td>8 data bytes</td> <td>12 data bytes</td> </tr> <tr> <td>1</td> <td>0</td> <td>1</td> <td>0</td> <td></td> <td>16 data bytes</td> </tr> <tr> <td>1</td> <td>0</td> <td>1</td> <td>1</td> <td></td> <td>20 data bytes</td> </tr> <tr> <td>1</td> <td>1</td> <td>0</td> <td>0</td> <td></td> <td>24 data bytes</td> </tr> <tr> <td>1</td> <td>1</td> <td>0</td> <td>1</td> <td></td> <td>32 data bytes</td> </tr> <tr> <td>1</td> <td>1</td> <td>1</td> <td>0</td> <td></td> <td>48 data bytes</td> </tr> <tr> <td>1</td> <td>1</td> <td>1</td> <td>1</td> <td></td> <td>64 data bytes</td> </tr> </tbody> </table>	b31	b30	b29	b28	Classical CAN Frame	CANFD Frame	0	0	0	0	0 data bytes		0	0	0	1	1 data byte		0	0	1	0	2 data bytes		0	0	1	1	3 data bytes		0	1	0	0	4 data bytes		0	1	0	1	5 data bytes		0	1	1	0	6 data bytes		0	1	1	1	7 data bytes		1	0	0	0	8 data bytes		1	0	0	1	8 data bytes	12 data bytes	1	0	1	0		16 data bytes	1	0	1	1		20 data bytes	1	1	0	0		24 data bytes	1	1	0	1		32 data bytes	1	1	1	0		48 data bytes	1	1	1	1		64 data bytes
b31	b30	b29	b28	Classical CAN Frame	CANFD Frame																																																																																																					
0	0	0	0	0 data bytes																																																																																																						
0	0	0	1	1 data byte																																																																																																						
0	0	1	0	2 data bytes																																																																																																						
0	0	1	1	3 data bytes																																																																																																						
0	1	0	0	4 data bytes																																																																																																						
0	1	0	1	5 data bytes																																																																																																						
0	1	1	0	6 data bytes																																																																																																						
0	1	1	1	7 data bytes																																																																																																						
1	0	0	0	8 data bytes																																																																																																						
1	0	0	1	8 data bytes	12 data bytes																																																																																																					
1	0	1	0		16 data bytes																																																																																																					
1	0	1	1		20 data bytes																																																																																																					
1	1	0	0		24 data bytes																																																																																																					
1	1	0	1		32 data bytes																																																																																																					
1	1	1	0		48 data bytes																																																																																																					
1	1	1	1		64 data bytes																																																																																																					
27 to 16	CFPTR[11:0]	All 0	R/W	Transmit/Receive FIFO Buffer Label Data																																																																																																						
				<ul style="list-style-type: none"> When CFM[1:0] value is 01b (transmit mode): Set the label information to be stored in the transmit history buffer. Only bits CFPTR[7:0] are valid. When CFM[1:0] value is 00b (receive mode): The label information of the received message can be read. 																																																																																																						

Bit	Bit Name	Initial Value	R/W	Description
15 to 0	CFTS[15:0]	All 0	R/W	Transmit/Receive FIFO Buffer Timestamp Data These bits are valid only when the CFM[1:0] value is 00b (receive mode). The timestamp value of the received message can be read.

This register is writable only when the CFM[1:0] value in the RSCFDnCFDCFCCK register is 01b (transmit mode). This register is readable only when the CFM[1:0] value is 00b (receive mode). This register should not be read or written when the CFM[1:0] value is 10b (gateway mode).

CFDLC[3:0] Bits

These bits indicate the data length of the received message stored in the transmit/receive FIFO buffer when the CFM[1:0] value is 00b.

When the CFM[1:0] value is 01b, these bits are used to set the data length of the message to be transmitted from the transmit/receive FIFO buffer.

When the CFDLC[3:0] bits are set to 1001b or more while the CFFDF bit in the RSCFDnCFDCFFDCSTSk register is 0 (CAN frame), 8-byte data is transmitted actually. When the CFFDF bit is 1 (CANFD frame), the settable value range varies depending on the settings of the TMME bit in the RSCFDnCFDCmFDCFG register and the CFPLS[2:0] bits in the RSCFDnCFDCFCCK register.

- When TMME bit = 0 (transmit buffer merge mode disabled):
A value of 0000b to 1111b is settable. If the specified data length exceeds the payload storage size specified by the CFPLS[2:0] bits, excessive payloads are padded by H'CC.
- When TMME bit = 1 (transmit buffer merge mode enabled):
Set the data length within the payload storage size specified by the CFPLS[2:0] bits.

CFPTR[11:0] Bits

These bits indicate the label information attached to the received message stored in the transmit/receive FIFO buffer when the CFM[1:0] value is 00b. When the CFM[1:0] value is 01b, the CFPTR[7:0] value is stored in the transmit history buffer when message transmission has been completed.

CFTS[15:0] Bits

These bits indicate the timestamp value of the message stored in the transmit/receive FIFO buffer. These bits are valid when the CFM[1:0] value is 00b.

28.4.8.6 RSCFDnCFDCFFDCSTSk — Transmit/Receive FIFO CANFD Configuration/ Status Register (k = 0 to 5)

Access Size: RSCFDnCFDCFFDCSTSk register can be read/written in 32-bit units
 RSCFDnCFDCFFDCSTSkL, RSCFDnCFDCFFDCSTSkH registers can be read/written in 16-bit units
 RSCFDnCFDCFFDCSTSkLL, RSCFDnCFDCFFDCSTSkLH, RSCFDnCFDCFFDCSTSkHL,
 RSCFDnCFDCFFDCSTSkHH registers can be read/written in 8-bit units

Address(es): RSCFDnCFDCFFDCSTSk: <RSCFDn_base> + H'3408 + (H'80 × k)
 RSCFDnCFDCFFDCSTSkL: <RSCFDn_base> + H'3408 + (H'80 × k),
 RSCFDnCFDCFFDCSTSkH: <RSCFDn_base> + H'340A + (H'80 × k)
 RSCFDnCFDCFFDCSTSkLL: <RSCFDn_base> + H'3408 + (H'80 × k),
 RSCFDnCFDCFFDCSTSkLH: <RSCFDn_base> + H'3409 + (H'80 × k),
 RSCFDnCFDCFFDCSTSkHL: <RSCFDn_base> + H'340A + (H'80 × k),
 RSCFDnCFDCFFDCSTSkHH: <RSCFDn_base> + H'340B + (H'80 × k)

Initial Value: H'0000 0000

Bit	31	30	29	28	27	26	25	24	23	22	21	20	19	18	17	16
	—	—	—	—	—	—	—	—	—	—	—	—	—	—	—	—
Initial Value	0	0	0	0	0	0	0	0	0	0	0	0	0	0	0	0
R/W	R	R	R	R	R	R	R	R	R	R	R	R	R	R	R	R
Bit	15	14	13	12	11	10	9	8	7	6	5	4	3	2	1	0
	—	—	—	—	—	—	—	—	—	—	—	—	—	CFFDF	CFBRS	CFESI
Initial Value	0	0	0	0	0	0	0	0	0	0	0	0	0	0	0	0
R/W	R	R	R	R	R	R	R	R	R	R	R	R	R	R/W	R/W	R/W

Bit	Bit Name	Initial Value	R/W	Description
31 to 3	—	All 0	R	Reserved These bits are read as the value after reset.
2	CFFDF	0	R/W	FDF 0: Classical CAN frame 1: CANFD frame
1	CFBRS	0	R/W	BRS 0: The bit rate in the data area does not change. 1: The bit rate in the data area changes.
0	CFESI	0	R/W	ESI 0: Error active node 1: Error passive node

This register is writable only when the CFM[1:0] value in the RSCFDnCFDCFCCK register is 01b (transmit mode). This register is readable only when the CFM[1:0] value is 00b (receive mode). Do not read or write this register when the CFM[1:0] value is 10b (gateway mode).

CFFDF Bit

When the CFM[1:0] value is 00b, this bit indicates the FD format (classical CAN frame or CANFD frame) of the message stored in the transmit/receive FIFO buffer. When the CFM[1:0] value is 01b, this bit is used to set the FD format of the message to be transmitted from the transmit/receive FIFO buffer.

CFBRS Bit

When the CFM[1:0] value is 00b, if the CFFDF bit is 1, this bit indicates the BRS bit value of the message stored in the transmit/receive FIFO buffer. If the CFFDF bit is 0, this bit is always read as 0.

When the CFM[1:0] value is 01b, if the CFFDF bit is 1, this bit is used to set the BRS bit value of the message to be transmitted from the transmit/receive FIFO buffer. If the CFFDF bit is 0, write 0 to this bit.

CFESI Bit

When the CFM[1:0] value is 00b, if the CFFDF bit is 1, this bit indicates the ESI bit value of the message stored in the transmit/receive FIFO buffer. If the CFFDF bit is 0, this bit is always read as 0.

When the CFM[1:0] value is 01b, if the CFFDF bit is 1, this bit is used to set the ESI bit value of the message to be transmitted from the transmit/receive FIFO buffer. The set value is transmitted when the ESIC bit in the RSCFDnCFDCmFDCFG register is 1 and the channel is in the error active state. When the channel is in the error passive state, the ESI bit value that shows an error passive node is transmitted regardless of this bit value. When the CFFDF bit is 0, write 0 to this bit.

28.4.8.7 RSCFDnCFDCFDf_k — Transmit/receive FIFO Buffer Access Data Field d Register (d = 0 to 15, k = 0 to 5)

Access Size: RSCFDnCFDCFDf_k register can be read/written in 32-bit units
 RSCFDnCFDCFDf_kL, RSCFDnCFDCFDf_kH registers can be read/written in 16-bit units
 RSCFDnCFDCFDf_kLL, RSCFDnCFDCFDf_kLH, RSCFDnCFDCFDf_kHL, RSCFDnCFDCFDf_kHH registers can be read/written in 8-bit units

Address(es): RSCFDnCFDCFDf_k: <RSCFDn_base> + H'340C + (H'04 × d) + (H'80 × k)
 RSCFDnCFDCFDf_kL: <RSCFDn_base> + H'340C + (H'04 × d) + (H'80 × k),
 RSCFDnCFDCFDf_kH: <RSCFDn_base> + H'340E + (H'04 × d) + (H'80 × k)
 RSCFDnCFDCFDf_kLL: <RSCFDn_base> + H'340C + (H'04 × d) + (H'80 × k),
 RSCFDnCFDCFDf_kLH: <RSCFDn_base> + H'340D + (H'04 × d) + (H'80 × k),
 RSCFDnCFDCFDf_kHL: <RSCFDn_base> + H'340E + (H'04 × d) + (H'80 × k),
 RSCFDnCFDCFDf_kHH: <RSCFDn_base> + H'340F + (H'04 × d) + (H'80 × k)

Initial Value: H'0000 0000

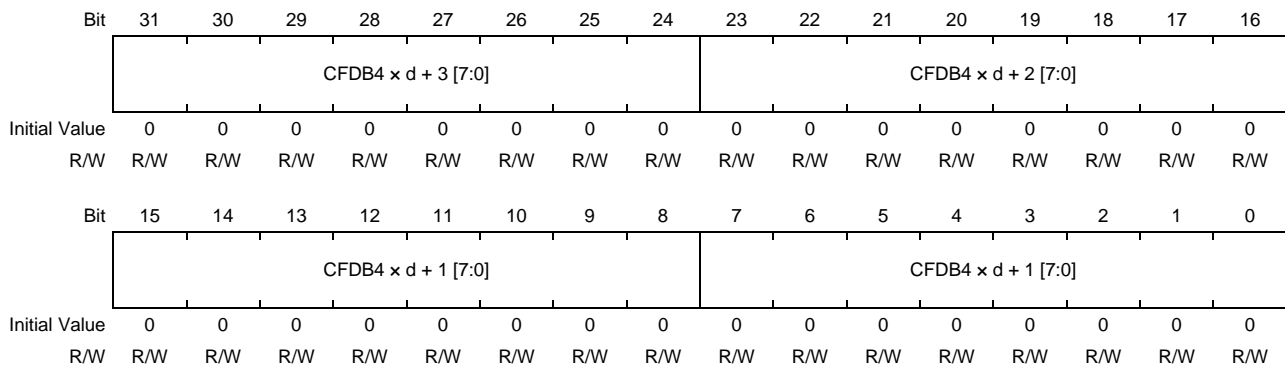

Bit	Bit Name	Initial Value	R/W	Description
31 to 24	CFDB4 × d + 3 [7:0]	All 0	R/W	Transmit/Receive FIFO Buffer Data Byte 4 × d + 3
23 to 16	CFDB4 × d + 2 [7:0]	All 0	R/W	Transmit/Receive FIFO Buffer Data Byte 4 × d + 2
15 to 8	CFDB4 × d + 1 [7:0]	All 0	R/W	Transmit/Receive FIFO Buffer Data Byte 4 × d + 1
7 to 0	CFDB4 × d + 0 [7:0]	All 0	R/W	Transmit/Receive FIFO Buffer Data Byte 4 × d + 0

- When CFM[1:0] value is 01b (transmit mode): Set the transmit/receive FIFO buffer data.
- When CFM[1:0] value is 00b (receive mode): The message data stored in the transmit/receive FIFO buffer can be read.

This register is writable only when the CFM[1:0] value in the RSCFDnCFDCFCCK register is 01b (transmit mode). This register is readable only when the CFM[1:0] value is 00b (receive mode). When the CFDLC[3:0] value in the RSCFDnCFDCFPTRk register is smaller than the payload storage size of the transmit/receive FIFO buffer, data bytes for which no data is set are read as H'00.

Specify the payload storage size of the transmit/receive FIFO buffer by the CFPLS[2:0] bits in the RSCFDnCFDCFCCK register. Do not read or write the RSCFDnCFDCFDf_k register corresponding to an area larger than the specified size.

This register should not be read or written when the CFM[1:0] value is 10b (gateway mode).

28.4.9 Details of FIFO Status-related Registers

28.4.9.1 RSCFDnCFDFESTS — FIFO Empty Status Register

Access Size: RSCFDnCFDFESTS register can be read only in 32-bit units
RSCFDnCFDFESTSL, RSCFDnCFDFESTSH registers can be read only in 16-bit units
RSCFDnCFDFESTSLL, RSCFDnCFDFESTSLH, RSCFDnCFDFESTSHL, RSCFDnCFDFESTSHH registers can be read only in 8-bit units

Address(es): RSCFDnCFDFESTS: <RSCFDn_base> + H'0238
RSCFDnCFDFESTSL: <RSCFDn_base> + H'0238, RSCFDnCFDFESTSH: <RSCFDn_base> + H'023A
RSCFDnCFDFESTSLL: <RSCFDn_base> + H'0238, RSCFDnCFDFESTSLH: <RSCFDn_base> + H'0239,
RSCFDnCFDFESTSHL: <RSCFDn_base> + H'023A, RSCFDnCFDFESTSHH: <RSCFDn_base> + H'023B

Initial Value: H'03FF FFFF

Bit	31	30	29	28	27	26	25	24	23	22	21	20	19	18	17	16
	—	—	—	—	—	—	—	—	—	—	—	—	—	—	—	—
Initial Value	0	0	0	0	0	0	1	1	1	1	1	1	1	1	1	1
R/W	R	R	R	R	R	R	R	R	R	R	R	R	R	R	R	R
Bit	15	14	13	12	11	10	9	8	7	6	5	4	3	2	1	0
	—	—	CF5EMP	CF4EMP	CF3EMP	CF2EMP	CF1EMP	CF0EMP	RF7EMP	RF6EMP	RF5EMP	RF4EMP	RF3EMP	RF2EMP	RF1EMP	RF0EMP
			P	P	P	P	P	P	P	P	P	P	P	P	P	P
Initial Value	1	1	1	1	1	1	1	1	1	1	1	1	1	1	1	1
R/W	R	R	R	R	R	R	R	R	R	R	R	R	R	R	R	R

Bit	Bit Name	Initial Value	R/W	Description
31 to 14	—	H'0_0FFF	R	Reserved These bits are read as the value after reset.
13	CF5EMP	1	R	Transmit/Receive FIFO Buffer Empty Status Flag 0: Transmit/receive FIFO buffer k contains a message. 1: Transmit/receive FIFO buffer k contains no message. (k = 0 to 5)
12	CF4EMP	1	R	
11	CF3EMP	1	R	
10	CF2EMP	1	R	
9	CF1EMP	1	R	
8	CF0EMP	1	R	
7	RF7EMP	1	R	Receive FIFO Buffer Empty Status Flag 0: Receive FIFO buffer x contains an unread message. 1: Receive FIFO buffer x contains no unread message (buffer empty). (x = 0 to 7)
6	RF6EMP	1	R	
5	RF5EMP	1	R	
4	RF4EMP	1	R	
3	RF3EMP	1	R	
2	RF2EMP	1	R	
1	RF1EMP	1	R	
0	RF0EMP	1	R	

This RSCFDnCFDFESTS register is set to 03FF H'FFFF in global reset mode.

CFkEMP Flag (k = 0 to 5)

The CFkEMP flag is set to 1 when the CFEMP flag in the RSCFDnCFDCFSTSk register is set to 1 (the transmit/receive FIFO buffer contains no message (buffer empty)). When the CFEMP flag is cleared to 0 (the transmit/receive FIFO buffer contains messages), the CFkEMP flag is cleared to 0.

RFxEMP Flag (x = 0 to 7)

The RFxEMP flag is set to 1 when the RFEMP flag in the RSCFDnCFDRFSTSt register is set to 1 (the receive FIFO buffer contains no unread message). When the RFEMP flag is cleared to 0 (the receive FIFO buffer contains unread messages), the RFxEMP flag is cleared to 0.

28.4.9.2 RSCFDnCFDFFSTS — FIFO Full Status Register

Access Size: RSCFDnCFDFFSTS register can be read only in 32-bit units
RSCFDnCFDFFSTSL, RSCFDnCFDFFSTSH registers can be read only in 16-bit units
RSCFDnCFDFFSTSL, RSCFDnCFDFFSTSLH, RSCFDnCFDFFSTSHL, RSCFDnCFDFFSTSHH registers can be read only in 8-bit units

Address(es): RSCFDnCFDFFSTS: <RSCFDn_base> + H'023C
RSCFDnCFDFFSTSL: <RSCFDn_base> + H'023C, RSCFDnCFDFFSTSH: <RSCFDn_base> + H'023E
RSCFDnCFDFFSTSL: <RSCFDn_base> + H'023C, RSCFDnCFDFFSTSLH: <RSCFDn_base> + H'023D,
RSCFDnCFDFFSTSHL: <RSCFDn_base> + H'023E, RSCFDnCFDFFSTSHH: <RSCFDn_base> + H'023F

Initial Value: H'0000 0000

Bit	31	30	29	28	27	26	25	24	23	22	21	20	19	18	17	16
	—	—	—	—	—	—	—	—	—	—	—	—	—	—	—	—
Initial Value	0	0	0	0	0	0	0	0	0	0	0	0	0	0	0	0
R/W	R	R	R	R	R	R	R	R	R	R	R	R	R	R	R	R
Bit	15	14	13	12	11	10	9	8	7	6	5	4	3	2	1	0
	—	—	CF5FLL	CF4FLL	CF3FLL	CF2FLL	CF1FLL	CF0FLL	RF7FLL	RF6FLL	RF5FLL	RF4FLL	RF3FLL	RF2FLL	RF1FLL	RF0FLL
Initial Value	0	0	0	0	0	0	0	0	0	0	0	0	0	0	0	0
R/W	R	R	R	R	R	R	R	R	R	R	R	R	R	R	R	R

Bit	Bit Name	Initial Value	R/W	Description
31 to 14	—	All 0	R	Reserved These bits are read as the value after reset.
13	CF5FLL	0	R	Transmit/Receive FIFO Buffer Full Status Flag 0: Transmit/receive buffer k is not full. 1: Transmit/receive buffer k is full. (k = 0 to 5)
12	CF4FLL	0	R	
11	CF3FLL	0	R	
10	CF2FLL	0	R	
9	CF1FLL	0	R	
8	CF0FLL	0	R	
7	RF7FLL	0	R	Receive FIFO Buffer Full Status Flag 0: Receive FIFO buffer x is not full. 1: Receive FIFO buffer x is full. (x = 0 to 7)
6	RF6FLL	0	R	
5	RF5FLL	0	R	
4	RF4FLL	0	R	
3	RF3FLL	0	R	
2	RF2FLL	0	R	
1	RF1FLL	0	R	
0	RF0FLL	0	R	

The RSCFDnCFDFFSTS register is cleared to H'0000 0000 in global reset mode.

CFkFLL Flag (k = 0 to 5)

The CFkFLL flag is set to 1 when the CFFLL flag in the RSCFDnCFDCFSTSk register is set to 1 (the transmit/receive FIFO buffer is full).

When the CFFLL flag is cleared to 0 (the transmit/receive FIFO buffer is not full), the CFkFLL flag is cleared to 0.

RFxFLl Flag (x = 0 to 7)

The RFxFLl flag is set to 1 when the RFFLL flag in the RSCFDnCFDRFSTs_x register is set to 1 (the receive FIFO buffer is full). When the RFFLL flag is cleared to 0 (the receive FIFO buffer is not full), the RFxFLl flag is cleared to 0.

28.4.9.3 RSCFDnCFDFMSTS — FIFO Message Lost Status Register

Access Size: RSCFDnCFDFMSTS register can be read only in 32-bit units
 RSCFDnCFDFMSTSL, RSCFDnCFDFMSTSH registers can be read only in 16-bit units
 RSCFDnCFDFMSTSL, RSCFDnCFDFMSTSLH, RSCFDnCFDFMSTSHL, RSCFDnCFDFMSTSHH registers can be read only in 8-bit units

Address(es): RSCFDnCFDFMSTS: <RSCFDn_base> + H'0240
 RSCFDnCFDFMSTSL: <RSCFDn_base> + H'0240, RSCFDnCFDFMSTSH: <RSCFDn_base> + H'0242
 RSCFDnCFDFMSTSL: <RSCFDn_base> + H'0240, RSCFDnCFDFMSTSLH: <RSCFDn_base> + H'0241,
 RSCFDnCFDFMSTSHL: <RSCFDn_base> + H'0242, RSCFDnCFDFMSTSHH: <RSCFDn_base> + H'0243

Initial Value: H'0000 0000

Bit	31	30	29	28	27	26	25	24	23	22	21	20	19	18	17	16
	—	—	—	—	—	—	—	—	—	—	—	—	—	—	—	—
Initial Value	0	0	0	0	0	0	0	0	0	0	0	0	0	0	0	0
R/W	R	R	R	R	R	R	R	R	R	R	R	R	R	R	R	R
Bit	15	14	13	12	11	10	9	8	7	6	5	4	3	2	1	0
	—	—	CF5MLT	CF4MLT	CF3MLT	CF2MLT	CF1MLT	CF0MLT	RF7MLT	RF6MLT	RF5MLT	RF4MLT	RF3MLT	RF2MLT	RF1MLT	RF0MLT
Initial Value	0	0	0	0	0	0	0	0	0	0	0	0	0	0	0	0
R/W	R	R	R	R	R	R	R	R	R	R	R	R	R	R	R	R

Bit	Bit Name	Initial Value	R/W	Description
31 to 14	—	All 0	R	Reserved These bits are read as the value after reset.
13	CF5MLT	0	R	Transmit/Receive FIFO Buffer Message Lost Status Flag 0: No transmit/receive FIFO buffer k message is lost. 1: A transmit/receive FIFO buffer k message is lost. (k = 0 to 5)
12	CF4MLT	0	R	
11	CF3MLT	0	R	
10	CF2MLT	0	R	
9	CF1MLT	0	R	
8	CF0MLT	0	R	
7	RF7MLT	0	R	Receive FIFO Buffer Message Lost Status Flag 0: No receive FIFO buffer x message is lost. 1: A receive FIFO buffer x message is lost. (x = 0 to 7)
6	RF6MLT	0	R	
5	RF5MLT	0	R	
4	RF4MLT	0	R	
3	RF3MLT	0	R	
2	RF2MLT	0	R	
1	RF1MLT	0	R	
0	RF0MLT	0	R	

The RSCFDnCFDFMSTS register is cleared to H'0000 0000 in global reset mode.

CFkMLT Flag (k = 0 to 5)

The CFkMLT flag is set to 1 when the CFMLT flag in the RSCFDnCFDFMSTSL register is set to 1 (a transmit/receive FIFO message is lost). When the CFMLT flag is cleared to 0, the CFkMLT flag is cleared to 0.

RFxMLT Flag (x = 0 to 7)

The RFxMLT flag is set to 1 when the RFMLT flag in the RSCFDnCFDREFTSx register is set to 1 (a receive FIFO message is lost). When the RFMLT flag is cleared to 0, the RFxMLT flag is cleared to 0.

28.4.9.4 RSCFDnCFDRFISTS — Receive FIFO Buffer Interrupt Flag Status Register

Access Size: RSCFDnCFDRFISTS register can be read only in 32-bit units
 RSCFDnCFDRFISTSL, RSCFDnCFDRFISTSH registers can be read only in 16-bit units
 RSCFDnCFDRFISTSLL, RSCFDnCFDRFISTSLH, RSCFDnCFDRFISTSHL, RSCFDnCFDRFISTSHH registers can be read only in 8-bit units

Address(es): RSCFDnCFDRFISTS: <RSCFDn_base> + H'0244
 RSCFDnCFDRFISTSL: <RSCFDn_base> + H'0244, RSCFDnCFDRFISTSH: <RSCFDn_base> + H'0246
 RSCFDnCFDRFISTSLL: <RSCFDn_base> + H'0244, RSCFDnCFDRFISTSLH: <RSCFDn_base> + H'0245,
 RSCFDnCFDRFISTSHL: <RSCFDn_base> + H'0246, RSCFDnCFDRFISTSHH: <RSCFDn_base> + H'0247

Initial Value: H'0000 0000

Bit	31	30	29	28	27	26	25	24	23	22	21	20	19	18	17	16
	—	—	—	—	—	—	—	—	—	—	—	—	—	—	—	—
Initial Value	0	0	0	0	0	0	0	0	0	0	0	0	0	0	0	0
R/W	R	R	R	R	R	R	R	R	R	R	R	R	R	R	R	R
Bit	15	14	13	12	11	10	9	8	7	6	5	4	3	2	1	0
	—	—	—	—	—	—	—	—	RF7IF	RF6IF	RF5IF	RF4IF	RF3IF	RF2IF	RF1IF	RF0IF
Initial Value	0	0	0	0	0	0	0	0	0	0	0	0	0	0	0	0
R/W	R	R	R	R	R	R	R	R	R	R	R	R	R	R	R	R

Bit	Bit Name	Initial Value	R/W	Description
31 to 8	—	All 0	R	Reserved These bits are read as the value after reset.
7	RF7IF	0	R	Receive FIFO Buffer Interrupt Request Status Flag 0: No receive FIFO buffer x interrupt request is present. 1: A receive FIFO buffer x interrupt request is present. (x = 0 to 7)
6	RF6IF	0	R	
5	RF5IF	0	R	
4	RF4IF	0	R	
3	RF3IF	0	R	
2	RF2IF	0	R	
1	RF1IF	0	R	
0	RF0IF	0	R	

The RSCFDnCFDRFISTS register is cleared to H'0000 0000 in global reset mode.

RFxIF Flag (x = 0 to 7)

The RFxIF flag is set to 1 when the RFIF flag in the RSCFDnCFDRFISTSx register is set to 1 (a receive FIFO interrupt request is present). When the RFIF flag is cleared to 0, the RFxIF flag is cleared to 0.

28.4.9.5 RSCFDnCFDCFRISTS — Transmit/receive FIFO Buffer Receive Interrupt Flag Status Register

Access Size: RSCFDnCFDCFRISTS register can be read only in 32-bit units
RSCFDnCFDCFRISTSL, RSCFDnCFDCFRISTSH registers can be read only in 16-bit units
RSCFDnCFDCFRISTSLL, RSCFDnCFDCFRISTSLH, RSCFDnCFDCFRISTSHL, RSCFDnCFDCFRISTSHH registers can be read only in 8-bit units

Address(es): RSCFDnCFDCFRISTS: <RSCFDn_base> + H'0248
RSCFDnCFDCFRISTSL: <RSCFDn_base> + H'0248, RSCFDnCFDCFRISTSH: <RSCFDn_base> + H'024A
RSCFDnCFDCFRISTSLL: <RSCFDn_base> + H'0248, RSCFDnCFDCFRISTSLH: <RSCFDn_base> + H'0249,
RSCFDnCFDCFRISTSHL: <RSCFDn_base> + H'024A, RSCFDnCFDCFRISTSHH: <RSCFDn_base> + H'024B

Initial Value: H'0000 0000

Bit	31	30	29	28	27	26	25	24	23	22	21	20	19	18	17	16
	—	—	—	—	—	—	—	—	—	—	—	—	—	—	—	—
Initial Value	0	0	0	0	0	0	0	0	0	0	0	0	0	0	0	0
R/W	R	R	R	R	R	R	R	R	R	R	R	R	R	R	R	R
Bit	15	14	13	12	11	10	9	8	7	6	5	4	3	2	1	0
	—	—	—	—	—	—	—	—	—	—	CF5RXIF	CF4RXIF	CF3RXIF	CF2RXIF	CF1RXIF	CF0RXIF
											F	F	F	F	F	F
Initial Value	0	0	0	0	0	0	0	0	0	0	0	0	0	0	0	0
R/W	R	R	R	R	R	R	R	R	R	R	R	R	R	R	R	R

Bit	Bit Name	Initial Value	R/W	Description
31 to 6	—	All 0	R	Reserved These bits are read as the value after reset.
5	CF5RXIF	0	R	Transmit/Receive FIFO Buffer Receive Interrupt Request Status Flag 0: No transmit/receive FIFO buffer k receive interrupt request is present. 1: A transmit/receive FIFO buffer k receive interrupt request is present. (k = 0 to 5)
4	CF4RXIF	0	R	
3	CF3RXIF	0	R	
2	CF2RXIF	0	R	
1	CF1RXIF	0	R	
0	CF0RXIF	0	R	

The RSCFDnCFDCFRISTS register is cleared to H'0000 0000 in global reset mode.

CFkRXIF Flag (k = 0 to 5)

The CFkRXIF flag is set to 1 when the CFRXIF flag in the RSCFDnCFDCFRISTSk register is set to 1 (a transmit/receive FIFO receive interrupt request is present). When the CFRXIF flag is cleared to 0, the CFkRXIF flag is cleared to 0.

28.4.9.6 RSCFDnCFDCFTISTS — Transmit/receive FIFO Buffer Transmit Interrupt Flag Status Register

Access Size: RSCFDnCFDCFTISTS register can be read only in 32-bit units
RSCFDnCFDCFTISTSL, RSCFDnCFDCFTISTSH registers can be read only in 16-bit units
RSCFDnCFDCFTISTSLL, RSCFDnCFDCFTISTSLH, RSCFDnCFDCFTISTSHL, RSCFDnCFDCFTISTSHH registers can be read only in 8-bit units

Address(es): RSCFDnCFDCFTISTS: <RSCFDn_base> + H'024C
RSCFDnCFDCFTISTSL: <RSCFDn_base> + H'024C, RSCFDnCFDCFTISTSH: <RSCFDn_base> + H'024E
RSCFDnCFDCFTISTSLL: <RSCFDn_base> + H'024C, RSCFDnCFDCFTISTSLH: <RSCFDn_base> + H'024D,
RSCFDnCFDCFTISTSHL: <RSCFDn_base> + H'024E, RSCFDnCFDCFTISTSHH: <RSCFDn_base> + H'024F

Initial Value: H'0000 0000

Bit	31	30	29	28	27	26	25	24	23	22	21	20	19	18	17	16
	—	—	—	—	—	—	—	—	—	—	—	—	—	—	—	—
Initial Value	0	0	0	0	0	0	0	0	0	0	0	0	0	0	0	0
R/W	R	R	R	R	R	R	R	R	R	R	R	R	R	R	R	R
Bit	15	14	13	12	11	10	9	8	7	6	5	4	3	2	1	0
	—	—	—	—	—	—	—	—	—	—	CF5TXIF	CF4TXIF	CF3TXIF	CF2TXIF	CF1TXIF	CF0TXIF
Initial Value	0	0	0	0	0	0	0	0	0	0	0	0	0	0	0	0
R/W	R	R	R	R	R	R	R	R	R	R	R	R	R	R	R	R

Bit	Bit Name	Initial Value	R/W	Description
31 to 6	—	All 0	R	Reserved These bits are read as the value after reset.
5	CF5TXIF	0	R	Transmit/Receive FIFO Buffer Transmit Interrupt Request Status Flag 0: No transmit/receive FIFO buffer k transmit interrupt request is present. 1: A transmit/receive FIFO buffer k transmit interrupt request is present. (k = 0 to 5)
4	CF4TXIF	0	R	
3	CF3TXIF	0	R	
2	CF2TXIF	0	R	
1	CF1TXIF	0	R	
0	CF0TXIF	0	R	

The RSCFDnCFDCFTISTS register is cleared to H'0000 0000 in global reset mode.

CFkTXIF Flag (k = 0 to 5)

The CFkTXIF flag is set to 1 when the CFTXIF flag in the RSCFDnCFDCFTISTSk register is set to 1 (a transmit/receive FIFO transmit interrupt request is present). When the CFTXIF flag is cleared to 0, the CFkTXIF flag is cleared to 0.

28.4.10 Details of FIFO DMA-related Registers

28.4.10.1 RSCFDnCFDCDTCT — DMA Enable Register

Access Size: RSCFDnCFDCDTCT register can be read/written in 32-bit units
RSCFDnCFDCDTCTL, RSCFDnCFDCDTCTH registers can be read/written in 16-bit units
RSCFDnCFDCDTCTL, RSCFDnCFDCDTCTLH, RSCFDnCFDCDTCTHL, RSCFDnCFDCDTCTHH registers can be read/written in 8-bit units

Address(es): RSCFDnCFDCDTCT: <RSCFDn_base> + H'0490
RSCFDnCFDCDTCTL: <RSCFDn_base> + H'0490
RSCFDnCFDCDTCTH: <RSCFDn_base> + H'0492
RSCFDnCFDCDTCTL: <RSCFDn_base> + H'0490, RSCFDnCFDCDTCTLH: <RSCFDn_base> + H'0491,
RSCFDnCFDCDTCTHL: <RSCFDn_base> + H'0492, RSCFDnCFDCDTCTHH: <RSCFDn_base> + H'0493

Initial Value: H'0000 0000

Bit	31	30	29	28	27	26	25	24	23	22	21	20	19	18	17	16
	—	—	—	—	—	—	—	—	—	—	—	—	—	—	—	—
Initial Value	0	0	0	0	0	0	0	0	0	0	0	0	0	0	0	0
R/W	R	R	R	R	R	R	R	R	R	R	R	R	R	R	R	R
Bit	15	14	13	12	11	10	9	8	7	6	5	4	3	2	1	0
	—	—	—	—	—	—	CFDMA E1	CFDMA E0	RFDMA E7	RFDMA E6	RFDMA E5	RFDMA E4	RFDMA E3	RFDMA E2	RFDMA E1	RFDMA E0
Initial Value	0	0	0	0	0	0	0	0	0	0	0	0	0	0	0	0
R/W	R	R	R/W	R/W	R/W	R/W	R/W	R/W	R/W	R/W	R/W	R/W	R/W	R/W	R/W	R/W

Bit	Bit Name	Initial Value	R/W	Description
31 to 10	—	All 0	R	Reserved These bits are read as the value after reset. The write value should be the value after reset.
9	CFDMAE1	0	R/W	Transmit/Receive FIFO Buffer 3 DMA Enable 0: A DMA transfer request of transmit/receive FIFO buffer 3 is disabled. 1: A DMA transfer request of transmit/receive FIFO buffer 3 is enabled.
8	CFDMAE0	0	R/W	Transmit/Receive FIFO Buffer 0 DMA Enable 0: A DMA transfer request of transmit/receive FIFO buffer 0 is disabled. 1: A DMA transfer request of transmit/receive FIFO buffer 0 is enabled.
7	RFDMAE7	0	R/W	Receive FIFO Buffer x DMA Enable 0: A DMA transfer request of receive FIFO buffer x is disabled. 1: A DMA transfer request of receive FIFO buffer x is enabled. (x = 0 to 7)
6	RFDMAE6	0	R/W	
5	RFDMAE5	0	R/W	
4	RFDMAE4	0	R/W	
3	RFDMAE3	0	R/W	
2	RFDMAE2	0	R/W	
1	RFDMAE1	0	R/W	
0	RFDMAE0	0	R/W	

Modify the RSCFDnCFDCDTCT register in global operating mode or global test mode.

CFDMAEm Bit

This bit is used to enable DMA transfer for transmit/receive FIFO buffer $3 \times m$ (the first transmit/receive FIFO buffer allocated to channel m). DMA transfer is enabled only for transmit/receive FIFO buffers for which the CFM[1:0] bits in the RSCFDnCFDCFCCK register is set to 00b (receive mode). Set this bit to 0 when the CFM[1:0] value is 01b (transmit mode) or 10b (gateway mode).

RFDMAEx Bit

This bit is used to enable DMA transfer for receive FIFO buffer x.

28.4.10.2 RSCFDnCFDCDTSTS — DMA Status Register

Access Size: RSCFDnCFDCDTSTS register can be read only in 32-bit units
 RSCFDnCFDCDTSTSL, RSCFDnCFDCDTSTSH registers can be read only in 16-bit units
 RSCFDnCFDCDTSTSLL, RSCFDnCFDCDTSTSLH, RSCFDnCFDCDTSTSHL, RSCFDnCFDCDTSTSHH registers can be read only in 8-bit units

Address(es): RSCFDnCFDCDTSTS: <RSCFDn_base> + H'0494
 RSCFDnCFDCDTSTSL: <RSCFDn_base> + H'0494
 RSCFDnCFDCDTSTSH: <RSCFDn_base> + H'0496
 RSCFDnCFDCDTSTSLL: <RSCFDn_base> + H'0494, RSCFDnCFDCDTSTSLH: <RSCFDn_base> + H'0495,
 RSCFDnCFDCDTSTSHL: <RSCFDn_base> + H'0496, RSCFDnCFDCDTSTSHH: <RSCFDn_base> + H'0497

Initial Value: H'0000 0000

Bit	31	30	29	28	27	26	25	24	23	22	21	20	19	18	17	16
	—	—	—	—	—	—	—	—	—	—	—	—	—	—	—	—
Initial Value	0	0	0	0	0	0	0	0	0	0	0	0	0	0	0	0
R/W	R	R	R	R	R	R	R	R	R	R	R	R	R	R	R	R
Bit	15	14	13	12	11	10	9	8	7	6	5	4	3	2	1	0
	—	—	—	—	—	—	CFDMA STS1	CFDMA STS0	RFDMA STS7	RFDMA STS6	RFDMA STS5	RFDMA STS4	RFDMA STS3	RFDMA STS2	RFDMA STS1	RFDMA ASTS0
Initial Value	0	0	0	0	0	0	0	0	0	0	0	0	0	0	0	0
R/W	R	R	R	R	R	R	R	R	R	R	R	R	R	R	R	R

Bit	Bit Name	Initial Value	R/W	Description
31 to 10	—	All 0	R	Reserved These bits are read as the value after reset.
9	CFDMASTS1	0	R	Transmit/Receive FIFO Buffer 3 DMA Status 0: DMA transfer of transmit/receive FIFO buffer 3 is not in progress. 1: DMA transfer of transmit/receive FIFO buffer 3 is in progress.
8	CFDMASTS0	0	R	Transmit/Receive FIFO Buffer 0 DMA Status 0: DMA transfer of transmit/receive FIFO buffer 0 is not in progress. 1: DMA transfer of transmit/receive FIFO buffer 0 is in progress.
7	RFDMASTS7	0	R	Receive FIFO Buffer x DMA Status 0: DMA transfer of receive FIFO buffer x is not in progress. 1: DMA transfer of receive FIFO buffer x is in progress. (x = 0 to 7)
6	RFDMASTS6	0	R	
5	RFDMASTS5	0	R	
4	RFDMASTS4	0	R	
3	RFDMASTS3	0	R	
2	RFDMASTS2	0	R	
1	RFDMASTS1	0	R	
0	RFDMASTS0	0	R	

CFDMASTSm Bit

When DMA transfer is enabled (CFDMAEm bit in the RSCFDnCFDCDTCT register is 1) for the transmit/receive FIFO buffer $3 \times m$ (the first transmit/receive FIFO buffer allocated to channel m) while the transmit/receive FIFO buffer contains one of more messages, the CFDMASTSm bit is set to 1 indicating that DMA transfer is in progress.

When all messages in the transmit/receive FIFO buffer have been transferred or DMA transfer is disabled (CFDMAEm bit is 0), the CFDMASTSm bit is cleared to 0 indicating that DMA transfer has been completed. If the CFDMAEm bit is set to 0 during DMA transfer, the CFDMASTSm bit is cleared to 0 after the ongoing DMA transfer has been completed (when the message that is being transferred has been transferred to the last byte in the payload storage area).

These bits are cleared to 0 in global reset mode.

RFDMASTx Bit

When DMA transfer is enabled (corresponding RFDMAEx bit in the RSCFDnCFDCDTCT register is 1) for the receive FIFO buffer x and the receive FIFO buffer contains one of more messages, the RFDMAEx bit is set to 1 indicating that DMA transfer is in progress.

When all messages in the receive FIFO buffer x have been transferred or DMA transfer is disabled (RFDMAEx bit = 0), the RFDMASTx bit is cleared to 0 indicating that DMA transfer has been completed. If the RFDMAEx bit is set to 0 during DMA transfer, the RFDMASTx bit is cleared to 0 after the ongoing DMA transfer has been completed (when the message that is being transferred has been transferred to the last byte in the payload storage area)

These bits are cleared to 0 in global reset mode.

28.4.11 Details of Transmit Buffer-related Registers

28.4.11.1 RSCFDnCFDTMCp — Transmit Buffer Control Register (p = 0 to 31)

Access Size: RSCFDnCFDTMCp registers can be read/written in 8-bit units

Address(es): RSCFDnCFDTMCp: <RSCFDn_base> + H'0250 + (H'01 × p)

Initial Value: H'00

Bit	7	6	5	4	3	2	1	0
	—	—	—	—	—	TMOM	TMTAR	TMTR
Initial Value	0	0	0	0	0	0	0	0
R/W	R	R	R	R	R	R/W	R/W*1	R/W*1

Bit	Bit Name	Initial Value	R/W	Description
7 to 3	—	All 0	R	Reserved These bits are read as the value after reset. The write value should be the value after reset.
2	TMOM	0	R/W	One-Shot Transmission Enable 0: One-shot transmission is disabled. 1: One-shot transmission is enabled.
1	TMTAR	0	R/W*1	Transmit Abort Request 0: Transmit abort is not requested. 1: Transmit abort is requested.
0	TMTR	0	R/W*1	Transmit Request 0: Transmission is not requested. 1: Transmission is requested.

Note 1. The only effective value for writing to this bit is 1, which sets the bit. Otherwise writing to the bit results in retention of its state.

When the RSCFDnCFDTMCp register meets any of the following conditions, set it to H'00.

- The RSCFDnCFDTMCp register corresponds to the transmit buffer number selected by the CFTML[3:0] bits in the RSCFDnCFDCFCCk register ($p = m \times 16 + \text{the value of CFTML}[3:0] \text{ bits}$).
- The RSCFDnCFDTMCp register corresponds to the transmit buffer allocated to the transmit queue by the TXQDC[3:0] bits in the RSCFDnCFDTXQCCm ($m = 0, 1$) register ($p = (m \times 16 + 15) + \text{the value of TXQDC}[3:0] \text{ bits}$).
- RSCFDnCFDTMCp register ($p = (m \times 16) + 1, (m \times 16) + 2, (m \times 16) + 4, \text{ or } (m \times 16) + 5$) corresponding to the transmit buffer allocated as a payload storage area when the TMME bit in the RSCFDnCFDCmFDCFG register is 1 (transmit buffer merge mode)

Bits in the RSCFDnCFDTMCp register are all cleared to 0 in channel reset mode. Modify the RSCFDnCFDTMCp register in channel communication mode or channel halt mode.

TMOM Bit

Setting this bit to 1 enables one-shot transmission. When transmission fails, retransmission defined in the CAN protocol is not performed.

Modify the TMOM bit when the TMTRM flag in the RSCFDnCFDTMSTSp register is set to 0. Set the TMOM bit to 1 together with the TMTR bit.

TMTAR Bit

Setting this bit to 1 generates a transmit abort request for the message stored in the transmit buffer. However, a message that is being transmitted or one that will be transmitted next cannot be aborted.

The TMTAR bit can be set to 1 when TMTR bit is 1.

The TMTAR bit is cleared to 0 when any of the following conditions is met, but cannot be cleared by the program writing 0 to the bit.

- Transmission has been completed.
- Transmit abort has been completed.
- An error or arbitration loss has been detected.

If this bit becomes 0 at the same time as the program writes 1 to this bit, this bit becomes 0.

TMTR Bit

Setting this bit to 1 transmits the message stored in the transmit buffer.

The TMTR bit is cleared to 0 when any of the following conditions is met, but cannot be cleared by the program writing 0 to the bit.

- Transmission has been completed.
- Transmit abort has been completed after the TMTAR bit was set to 1.
- An error or arbitration-lost has been detected with the TMOM bit set to 1.

Set the TMTR bit to 1 when the value of TMTRF[1:0] in the RSCFDnCFDTMSTSp register is 00b.

28.4.11.2 RSCFDnCFDTMSTSp — Transmit Buffer Status Register (p = 0 to 31)

Access Size: RSCFDnCFDTMSTSp registers can be read/written in 8-bit units

Address(es): RSCFDnCFDTMSTSp: <RSCFDn_base> + H'02D0 + (H'01 × p)

Initial Value: H'00

Bit	7	6	5	4	3	2	1	0
	—	—	—	TMTAR M	TMTRM	TMTRF[1:0]		TMTST S
Initial Value	0	0	0	0	0	0	0	0
R/W	R	R	R	R	R	R/W	R/W	R

Bit	Bit Name	Initial Value	R/W	Description
7 to 5	—	All 0	R	Reserved These bits are read as the value after reset. The write value should be the value after reset.
4	TMTARM	0	R	Transmit Buffer Transmit Abort Request Status Flag 0: No transmit abort request is present. 1: A transmit abort request is present.
3	TMTRM	0	R	Transmit Buffer Transmit Request Status Flag 0: No transmit request is present. 1: A transmit request is present.
2, 1	TMTRF[1:0]	All 0	R/W	Transmit Buffer Transmit Result Status Flag b2 b1 0 0: Transmission is in progress or no transmit request is present. 0 1: Transmit abort has been completed. 1 0: Transmission has been completed (without transmit abort request). 1 1: Transmission has been completed (with transmit abort request).
0	TMTSTS	0	R	Transmit Buffer Transmit Status Flag 0: Transmission is not in progress. 1: Transmission is in progress.

The RSCFDnCFDTMSTSp register is cleared to all 0 in channel reset mode.

TMTARM Flag

The TMTARM flag is set to 1 when the TMTAR bit in the RSCFDnCFDTMCp register is set to 1.

The TMTARM flag is set to 0 when the TMTAR bit in the RSCFDnCFDTMCp register is set to 0.

TMTRM Flag

The TMTRM flag is set to 1 when the TMTR bit in the RSCFDnCFDTMCp register is set to 1.

The TMTRM flag is set to 0 when the TMTR bit in the RSCFDnCFDTMCp register is set to 0.

TMTRF[1:0] Flag

This flag indicates the result of transmission from the transmit buffer.

00b: Transmission is in progress or no transmit request is present.

01b: Transmission from the transmit buffer was aborted.

10b: Transmission has been completed with the TMTAR bit in the RSCFDnCFDTMCp register set to 0 (transmit abort is not requested).

11b: Transmission has been completed with the TMTAR bit in the RSCFDnCFDTMCp register set to 1 (transmit abort is requested).

Write 00b to the TMTRF[1:0] flag in channel communication mode or channel halt mode. Do not write any value other than 00b to this flag.

TMTSTS Flag

This flag is set to 1 when transmission from the transmit buffer starts, and is cleared to 0 when transmission from the transmit buffer has been completed or terminated due to a bus error or arbitration lost.

28.4.11.3 RSCFDnCFDTMIDp — Transmit Buffer ID Register (p = 0 to 31)

Access Size: RSCFDnCFDTMIDp register can be read/written in 32-bit units
 RSCFDnCFDTMIDpL, RSCFDnCFDTMIDpH registers can be read/written in 16-bit units
 RSCFDnCFDTMIDpLL, RSCFDnCFDTMIDpLH, RSCFDnCFDTMIDpHL, RSCFDnCFDTMIDpHH registers can be read/written in 8-bit units

Address(es): RSCFDnCFDTMIDp: <RSCFDn_base> + H'4000 + (H'20 × p)
 RSCFDnCFDTMIDpL: <RSCFDn_base> + H'4000 + (H'20 × p),
 RSCFDnCFDTMIDpH: <RSCFDn_base> + H'4002 + (H'20 × p)
 RSCFDnCFDTMIDpLL: <RSCFDn_base> + H'4000 + (H'20 × p),
 RSCFDnCFDTMIDpLH: <RSCFDn_base> + H'4001 + (H'20 × p),
 RSCFDnCFDTMIDpHL: <RSCFDn_base> + H'4002 + (H'20 × p),
 RSCFDnCFDTMIDpHH: <RSCFDn_base> + H'4003 + (H'20 × p)

Initial Value: H'0000 0000

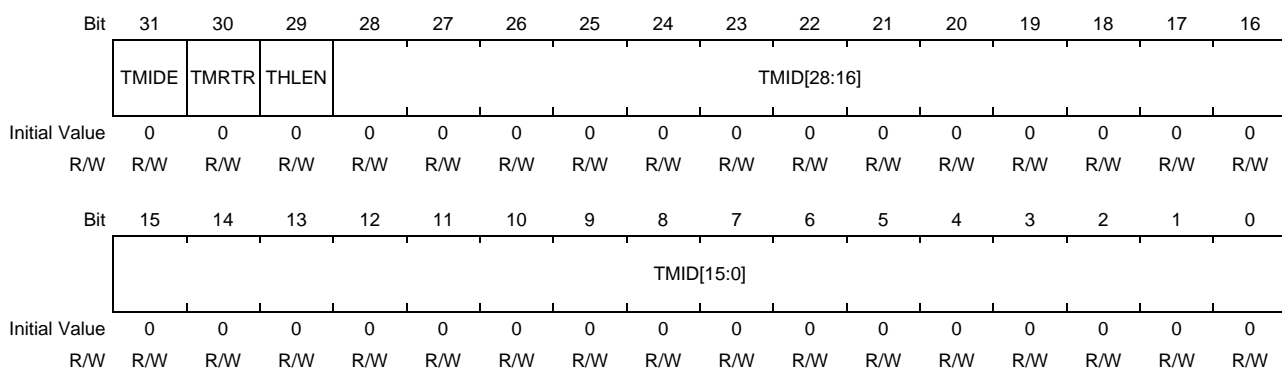

Bit	Bit Name	Initial Value	R/W	Description
31	TMIDE	0	R/W	Transmit Buffer IDE 0: Standard ID 1: Extended ID
30	TMRTR	0	R/W	Transmit Buffer RTR/RRS <ul style="list-style-type: none"> When the transmit message is a classical CAN frame 0: Data frame 1: Remote frame When the transmit message is a CANFD frame Write 0 to this bit.
29	THLEN	0	R/W	Transmit History Data Store Enable 0: Transmit history data is not stored in the buffer. 1: Transmit history data is stored in the buffer.
28 to 0	TMID[28:0]	All 0	R/W	Transmit Buffer ID Data Set standard ID or extended ID. For standard ID, write an ID to bits 10 to 0 and write 0 to bits 28 to 11.

Modify this register when the TMTRM bit in the corresponding RSCFDnCFDTMSTSp register is set to 0 (no transmit request is present). If this register is linked to a transmit/receive FIFO buffer, do not write data to this register. If this register is allocated to the transmit queue, only write data to a transmit buffer p ($p = m \times 16 + 15$) for the corresponding channel.

TMIDE Bit

This bit is used to set the ID format of the message to be transmitted from the transmit buffer.

TMRTR Bit

This bit is used to set the data format of the message to be transmitted from the transmit buffer.

Set this bit to 0 when the TMFDF bit in the RSCFDnCFDTMFDCTR_p register is 1 (CANFD frame).

THLEN Bit

When this bit is set to 1, the transmit history data (label information, buffer number, buffer type, and timestamp) of transmit messages is stored in the transmit history buffer after transmission is completed.

TMID[28:0] Bits

These bits are used to set the ID of the message to be transmitted from the transmit buffer.

28.4.11.4 RSCFDnCFDTMPTRp — Transmit Buffer Pointer Register (p = 0 to 31)

Access Size: RSCFDnCFDTMPTRp register can be read/written in 32-bit units
 RSCFDnCFDTMPTRpL, RSCFDnCFDTMPTRpH registers can be read/written in 16-bit units
 RSCFDnCFDTMPTRpLL, RSCFDnCFDTMPTRpLH, RSCFDnCFDTMPTRpHL, RSCFDnCFDTMPTRpHH registers can be read/written in 8-bit units

Address(es): RSCFDnCFDTMPTRp: <RSCFDn_base> + H'4004 + (H'20 × p)
 RSCFDnCFDTMPTRpL: <RSCFDn_base> + H'4004 + (H'20 × p),
 RSCFDnCFDTMPTRpH: <RSCFDn_base> + H'4006 + (H'20 × p)
 RSCFDnCFDTMPTRpLL: <RSCFDn_base> + H'4004 + (H'20 × p),
 RSCFDnCFDTMPTRpLH: <RSCFDn_base> + H'4005 + (H'20 × p),
 RSCFDnCFDTMPTRpHL: <RSCFDn_base> + H'4006 + (H'20 × p),
 RSCFDnCFDTMPTRpHH: <RSCFDn_base> + H'4007 + (H'20 × p)

Initial Value: H'0000 0000

Bit	31	30	29	28	27	26	25	24	23	22	21	20	19	18	17	16
	TMDLC[3:0]				—	—	—	—	TMPTR[7:0]							
Initial Value	0	0	0	0	0	0	0	0	0	0	0	0	0	0	0	0
R/W	R/W	R/W	R/W	R/W	R	R	R	R	R/W	R/W	R/W	R/W	R/W	R/W	R/W	R/W
Bit	15	14	13	12	11	10	9	8	7	6	5	4	3	2	1	0
	—	—	—	—	—	—	—	—	—	—	—	—	—	—	—	—
Initial Value	0	0	0	0	0	0	0	0	0	0	0	0	0	0	0	0
R/W	R	R	R	R	R	R	R	R	R	R	R	R	R	R	R	R

Bit	Bit Name	Initial Value	R/W	Description																																																																																																						
31 to 28	TMDLC[3:0]	All 0	R/W	Transmit Buffer DLC Data <table border="1" style="margin-left: 20px;"> <thead> <tr> <th>b31</th> <th>b30</th> <th>b29</th> <th>b28</th> <th>Classical CAN Frame</th> <th>CANFD Frame</th> </tr> </thead> <tbody> <tr><td>0</td><td>0</td><td>0</td><td>0</td><td>0 data bytes</td><td></td></tr> <tr><td>0</td><td>0</td><td>0</td><td>1</td><td>1 data byte</td><td></td></tr> <tr><td>0</td><td>0</td><td>1</td><td>0</td><td>2 data bytes</td><td></td></tr> <tr><td>0</td><td>0</td><td>1</td><td>1</td><td>3 data bytes</td><td></td></tr> <tr><td>0</td><td>1</td><td>0</td><td>0</td><td>4 data bytes</td><td></td></tr> <tr><td>0</td><td>1</td><td>0</td><td>1</td><td>5 data bytes</td><td></td></tr> <tr><td>0</td><td>1</td><td>1</td><td>0</td><td>6 data bytes</td><td></td></tr> <tr><td>0</td><td>1</td><td>1</td><td>1</td><td>7 data bytes</td><td></td></tr> <tr><td>1</td><td>0</td><td>0</td><td>0</td><td>8 data bytes</td><td></td></tr> <tr><td>1</td><td>0</td><td>0</td><td>1</td><td>8 data bytes</td><td>12 data bytes</td></tr> <tr><td>1</td><td>0</td><td>1</td><td>0</td><td></td><td>16 data bytes</td></tr> <tr><td>1</td><td>0</td><td>1</td><td>1</td><td></td><td>20 data bytes</td></tr> <tr><td>1</td><td>1</td><td>0</td><td>0</td><td></td><td>24 data bytes</td></tr> <tr><td>1</td><td>1</td><td>0</td><td>1</td><td></td><td>32 data bytes</td></tr> <tr><td>1</td><td>1</td><td>1</td><td>0</td><td></td><td>48 data bytes</td></tr> <tr><td>1</td><td>1</td><td>1</td><td>1</td><td></td><td>64 data bytes</td></tr> </tbody> </table>	b31	b30	b29	b28	Classical CAN Frame	CANFD Frame	0	0	0	0	0 data bytes		0	0	0	1	1 data byte		0	0	1	0	2 data bytes		0	0	1	1	3 data bytes		0	1	0	0	4 data bytes		0	1	0	1	5 data bytes		0	1	1	0	6 data bytes		0	1	1	1	7 data bytes		1	0	0	0	8 data bytes		1	0	0	1	8 data bytes	12 data bytes	1	0	1	0		16 data bytes	1	0	1	1		20 data bytes	1	1	0	0		24 data bytes	1	1	0	1		32 data bytes	1	1	1	0		48 data bytes	1	1	1	1		64 data bytes
b31	b30	b29	b28	Classical CAN Frame	CANFD Frame																																																																																																					
0	0	0	0	0 data bytes																																																																																																						
0	0	0	1	1 data byte																																																																																																						
0	0	1	0	2 data bytes																																																																																																						
0	0	1	1	3 data bytes																																																																																																						
0	1	0	0	4 data bytes																																																																																																						
0	1	0	1	5 data bytes																																																																																																						
0	1	1	0	6 data bytes																																																																																																						
0	1	1	1	7 data bytes																																																																																																						
1	0	0	0	8 data bytes																																																																																																						
1	0	0	1	8 data bytes	12 data bytes																																																																																																					
1	0	1	0		16 data bytes																																																																																																					
1	0	1	1		20 data bytes																																																																																																					
1	1	0	0		24 data bytes																																																																																																					
1	1	0	1		32 data bytes																																																																																																					
1	1	1	0		48 data bytes																																																																																																					
1	1	1	1		64 data bytes																																																																																																					
27 to 24	—	All 0	R	Reserved These bits are read as the value after reset. The write value should be the value after reset.																																																																																																						
23 to 16	TMPTR[7:0]	All 0	R/W	Transmit Buffer Label Data Set the label information to be stored in the transmit history buffer.																																																																																																						

Bit	Bit Name	Initial Value	R/W	Description
15 to 0	—	All 0	R	Reserved These bits are read as the value after reset. The write value should be the value after reset.

Modify this register when the TMTRM bit in the corresponding RSCFDnCFDTMSTSp register is set to 0 (no transmit request is present). If this register is linked to a transmit/receive FIFO buffer, do not write to this register. If this register is allocated to the transmit queue, only write to a transmit buffer p ($p = m \times 16 + 15$) for the corresponding channel.

TMDLC[3:0] Bits

These bits are used to set the data length of the message to be transmitted from the transmit buffer when the TMRTR bit in the RSCFDnCFDTMIDp register is set to 0 (data frame).

When the TMDLC[3:0] bits are set to 1001b or more while the TMFDF bit in the RSCFDnCFDTMFDCTRp register is 0 (classical CAN frame), 8-byte data is transmitted actually. When the MFDF bit is 1 (CANFD frame), the settable value range varies depending on the setting of the TMME bit in the RSCFDnCFDCmFDCFG register.

- When the TMME bit = 0 (transmit buffer merge mode disabled):
A value of 0000b to 1111b is settable. If a value larger than 1100b is set, payloads exceeding 20 bytes are padded by H'CC.
- When the TMME bit = 1 (transmit buffer merge mode enabled):
When the corresponding transmit buffer number $p = (m \times 16) + 0$ or $(m \times 16) + 3$, a value of 0000b to 1111b is settable. In other cases, set a value of 0000b to 1011b (20 data bytes).

When the TMRTR bit is 1 (remote frame), set the data length of a message to be requested.

TMPTR[7:0] Bits

When message transmission has been completed, the TMPTR[7:0] value is stored in the transmit history buffer.

28.4.11.5 RSCFDnCFDTMFDCTR_p — Transmit Buffer CANFD Configuration Register (p = 0 to 31)

Access Size: RSCFDnCFDTMFDCTR_p register can be read/written in 32-bit units
 RSCFDnCFDTMFDCTR_{pL}, RSCFDnCFDTMFDCTR_{pH} registers can be read/written in 16-bit units
 RSCFDnCFDTMFDCTR_{pLL}, RSCFDnCFDTMFDCTR_{pLH}, RSCFDnCFDTMFDCTR_{pHL},
 RSCFDnCFDTMFDCTR_{pHH} registers can be read/written in 8-bit units

Address(es): RSCFDnCFDTMFDCTR_p: <RSCFDn_base> + H'4008 + (H'20 × p)
 RSCFDnCFDTMFDCTR_{pL}: <RSCFDn_base> + H'4008 + (H'20 × p),
 RSCFDnCFDTMFDCTR_{pH}: <RSCFDn_base> + H'400A + (H'20 × p)
 RSCFDnCFDTMFDCTR_{pLL}: <RSCFDn_base> + H'4008 + (H'20 × p),
 RSCFDnCFDTMFDCTR_{pLH}: <RSCFDn_base> + H'4009 + (H'20 × p),
 RSCFDnCFDTMFDCTR_{pHL}: <RSCFDn_base> + H'400A + (H'20 × p),
 RSCFDnCFDTMFDCTR_{pHH}: <RSCFDn_base> + H'400B + (H'20 × p)

Initial Value: H'0000 0000

Bit	31	30	29	28	27	26	25	24	23	22	21	20	19	18	17	16
	—	—	—	—	—	—	—	—	—	—	—	—	—	—	—	—
Initial Value	0	0	0	0	0	0	0	0	0	0	0	0	0	0	0	0
R/W	R	R	R	R	R	R	R	R	R	R	R	R	R	R	R	R
Bit	15	14	13	12	11	10	9	8	7	6	5	4	3	2	1	0
	—	—	—	—	—	—	—	—	—	—	—	—	—	TMFDF	TMBRS	TMESI
Initial Value	0	0	0	0	0	0	0	0	0	0	0	0	0	0	0	0
R/W	R	R	R	R	R	R	R	R	R	R	R	R	R	R/W	R/W	R/W

Bit	Bit Name	Initial Value	R/W	Description
31 to 3	—	All 0	R	Reserved These bits are read as the value after reset. The write value should be the value after reset.
2	TMFDF	0	R/W	FD format 0: Classical CAN frame 1: CANFD frame
1	TMBRS	0	R/W	BRS 0: The bit rate in the data area does not change. 1: The bit rate in the data area changes.
0	TMESI	0	R/W	ESI 0: Error active node 1: Error passive node

Modify this register when the TMTRM bit in the corresponding RSCFDnCFDTMSTSp register is 0 (transmission not requested). When this register is linked to the transmit/receive FIFO buffer, do not write data to this register. When this register is allocated to the transmit queue, write data only to transmit buffer p (p = m × 16 + 15) of the corresponding channel.

TMFDF Bit

This bit is used to set the FD format of the message to be transmitted from the transmit buffer.

TMBR5 Bit

When this bit is set to 1 while the TMFDF bit is 1, the data area of a transmit message is transmitted at the data bit rate. When the TMFDF bit is 0, write 0 to this bit.

TMESI Bit

This bit is used to set the ESI bit value of the message to be transmitted from the transmit buffer when the TMFDF bit is 1. The set value is transmitted when the ESIC bit in the RSCFDnCFDCmFDCFG register is 1 and the channel is in the error active state. When the channel is in the error passive state, the ESI bit value that shows an error passive node is transmitted regardless of this bit value. When the TMFDF bit is 0, write 0 to this bit.

28.4.11.6 RSCFDnCFDTMDFb_p — Transmit Buffer Data Field b Register (b = 0 to 4, p = 0 to 31)

Access Size: RSCFDnCFDTMDFb_p register can be read/written in 32-bit units
 RSCFDnCFDTMDFb_pL, RSCFDnCFDTMDFb_pH registers can be read/written in 16-bit units
 RSCFDnCFDTMDFb_pLL, RSCFDnCFDTMDFb_pLH, RSCFDnCFDTMDFb_pHL, RSCFDnCFDTMDFb_pHH registers can be read/written in 8-bit units

Address(es): RSCFDnCFDTMDFb_p: $\langle \text{RSCFDn_base} \rangle + \text{H}'400\text{C} + (\text{H}'04 \times b) + (\text{H}'20 \times p)$
 RSCFDnCFDTMDFb_pL: $\langle \text{RSCFDn_base} \rangle + \text{H}'400\text{C} + (\text{H}'04 \times b) + (\text{H}'20 \times p)$,
 RSCFDnCFDTMDFb_pH: $\langle \text{RSCFDn_base} \rangle + \text{H}'400\text{E} + (\text{H}'04 \times b) + (\text{H}'20 \times p)$
 RSCFDnCFDTMDFb_pLL: $\langle \text{RSCFDn_base} \rangle + \text{H}'400\text{C} + (\text{H}'04 \times b) + (\text{H}'20 \times p)$,
 RSCFDnCFDTMDFb_pLH: $\langle \text{RSCFDn_base} \rangle + \text{H}'400\text{D} + (\text{H}'04 \times b) + (\text{H}'20 \times p)$,
 RSCFDnCFDTMDFb_pHL: $\langle \text{RSCFDn_base} \rangle + \text{H}'400\text{E} + (\text{H}'04 \times b) + (\text{H}'20 \times p)$,
 RSCFDnCFDTMDFb_pHH: $\langle \text{RSCFDn_base} \rangle + \text{H}'400\text{F} + (\text{H}'04 \times b) + (\text{H}'20 \times p)$

Initial Value: H'0000 0000

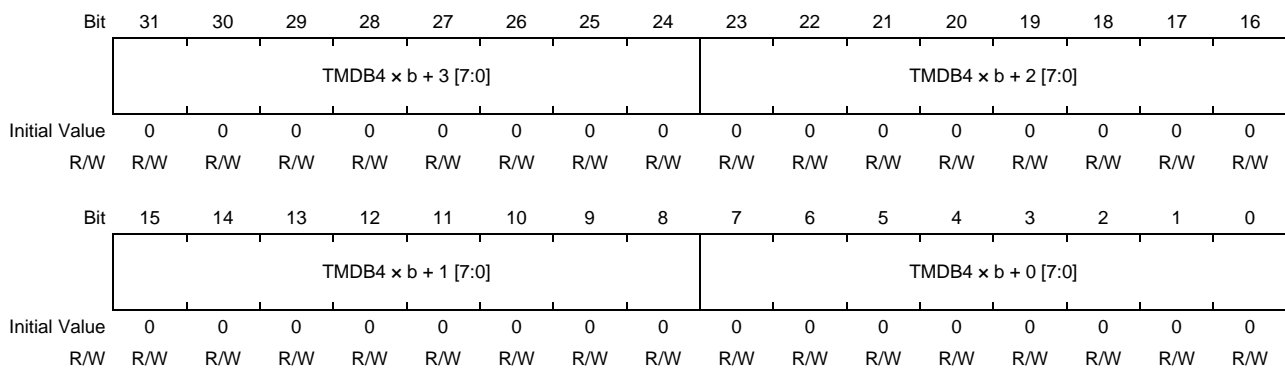

Bit	Bit Name	Initial Value	R/W	Description
31 to 24	TMDB4 × b + 3 [7:0]	All 0	R/W	Transmit Buffer Data Byte 4 × b + 3
23 to 16	TMDB4 × b + 2 [7:0]	All 0	R/W	Transmit Buffer Data Byte 4 × b + 2
15 to 8	TMDB4 × b + 1 [7:0]	All 0	R/W	Transmit Buffer Data Byte 4 × b + 1
7 to 0	TMDB4 × b + 0 [7:0]	All 0	R/W	Transmit Buffer Data Byte 4 × b + 0
Set the transmit buffer data.				

Modify this register when the TMTRM bit in the corresponding RSCFDnCFDTMSTSp register is set to 0 (no transmit request is present). If this register is linked to a transmit/receive FIFO buffer, do not write to this register. If this register is allocated to the transmit queue, only write to a transmit buffer p ($p = m \times 16 + 15$) for the corresponding channel.

28.4.11.7 RSCFDnCFDTMIECy — Transmit Buffer Interrupt Enable Configuration Register (y = 0)

Access Size: RSCFDnCFDTMIECy register can be read/written in 32-bit units
 RSCFDnCFDTMIECyL, RSCFDnCFDTMIECyH registers can be read/written in 16-bit units
 RSCFDnCFDTMIECyLL, RSCFDnCFDTMIECyLH, RSCFDnCFDTMIECyHL, RSCFDnCFDTMIECyHH registers can be read/written in 8-bit units

Address(es): RSCFDnCFDTMIECy: <RSCFDn_base> + H'0390 + (H'04 × y)
 RSCFDnCFDTMIECyL: <RSCFDn_base> + H'0390 + (H'04 × y),
 RSCFDnCFDTMIECyH: <RSCFDn_base> + H'0392 + (H'04 × y)
 RSCFDnCFDTMIECyLL: <RSCFDn_base> + H'0390 + (H'04 × y),
 RSCFDnCFDTMIECyLH: <RSCFDn_base> + H'0391 + (H'04 × y),
 RSCFDnCFDTMIECyHL: <RSCFDn_base> + H'0392 + (H'04 × y),
 RSCFDnCFDTMIECyHH: <RSCFDn_base> + H'0393 + (H'04 × y)

Initial Value: H'0000 0000

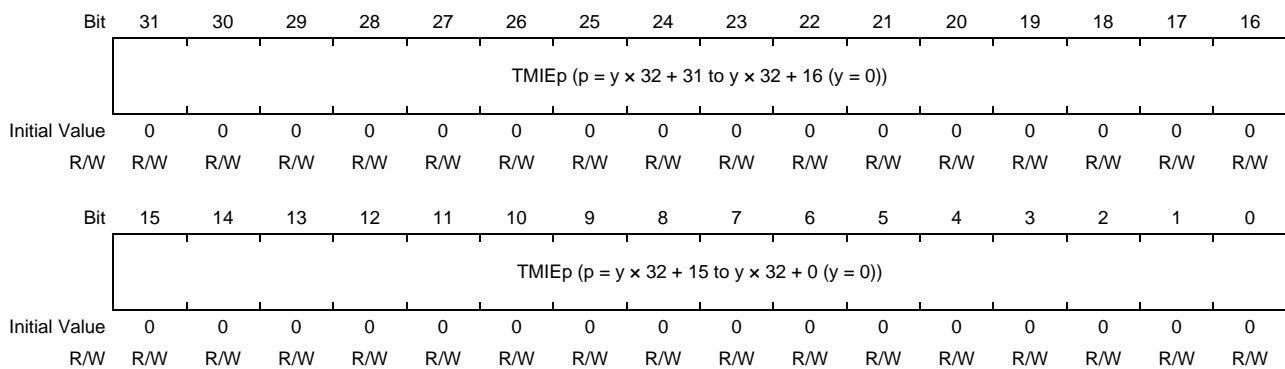

Bit	Bit Name	Initial Value	R/W	Description
31 to 16	TMIEp	All 0	R/W	Transmit Buffer Interrupt Enable p (p = y × 32 + 31 to y × 32 + 16) 0: Transmit buffer interrupt is disabled 1: Transmit buffer interrupt is enabled
15 to 0	TMIEp	All 0	R/W	Transmit Buffer Interrupt Enable p (p = y × 32 + 15 to y × 32 + 0) 0: Transmit buffer interrupt is disabled. 1: Transmit buffer interrupt is enabled.

TMIEp Bits (p = 0 to 31)

When any of these bits is set to 1 and the corresponding transmission has been completed, a transmit buffer interrupt request is generated.

Modify these bits when the TMTRM flag in the corresponding RSCFDnCFDTMSTSp register is 0 (no transmit request is present).

Write 0 to bits corresponding to transmit buffers linked to transmit/receive FIFO buffers or transmit buffers allocated to the transmit queue.

When the TMME bit in the RSCFDnCFDCmFDCFG register is 1 (transmit buffer merge mode enable), set the bit corresponding to the transmit buffer allocated as a payload storage area to 0.

Table 28.27 shows the bit assignment.

Table 28.27 TMIEp Bit Assignment

Bit	Channel	Transmit Buffer Number
0	0	0
1	0	1
.	.	.
.	.	.
15	0	15
16	1	0
.	.	.
.	.	.
30	1	14
31	1	15

28.4.12 Details of Transmit Buffer Status-related Registers

28.4.12.1 RSCFDnCFDTMTRSTSy — Transmit Buffer Transmit Request Status Register (y = 0)

Access Size: RSCFDnCFDTMTRSTSy register can be read only in 32-bit units
 RSCFDnCFDTMTRSTSyL, RSCFDnCFDTMTRSTSyH registers can be read only in 16-bit units
 RSCFDnCFDTMTRSTSyLL, RSCFDnCFDTMTRSTSyLH, RSCFDnCFDTMTRSTSyHL,
 RSCFDnCFDTMTRSTSyHH registers can be read only in 8-bit units

Address(es): RSCFDnCFDTMTRSTSy: <RSCFDn_base> + H'0350 + (H'04 × y)
 RSCFDnCFDTMTRSTSyL: <RSCFDn_base> + H'0350 + (H'04 × y),
 RSCFDnCFDTMTRSTSyH: <RSCFDn_base> + H'0352 + (H'04 × y)
 RSCFDnCFDTMTRSTSyLL: <RSCFDn_base> + H'0350 + (H'04 × y),
 RSCFDnCFDTMTRSTSyLH: <RSCFDn_base> + H'0351 + (H'04 × y),
 RSCFDnCFDTMTRSTSyHL: <RSCFDn_base> + H'0352 + (H'04 × y),
 RSCFDnCFDTMTRSTSyHH: <RSCFDn_base> + H'0353 + (H'04 × y)

Initial Value: H'0000 0000

Bit	31	30	29	28	27	26	25	24	23	22	21	20	19	18	17	16
	TMTRSTSp (p = y × 32 + 31 to y × 32 + 16 (y = 0))															
Initial Value	0	0	0	0	0	0	0	0	0	0	0	0	0	0	0	0
R/W	R	R	R	R	R	R	R	R	R	R	R	R	R	R	R	R
Bit	15	14	13	12	11	10	9	8	7	6	5	4	3	2	1	0
	TMTRSTSp (p = y × 32 + 15 to y × 32 + 0 (y = 0))															
Initial Value	0	0	0	0	0	0	0	0	0	0	0	0	0	0	0	0
R/W	R	R	R	R	R	R	R	R	R	R	R	R	R	R	R	R

Bit	Bit Name	Initial Value	R/W	Description
31 to 16	TMTRSTSp	All 0	R	Transmit Buffer Transmit Request Status Flag p (p = y × 32 + 31 to y × 32 + 16) 0: No transmit request is present. 1: A transmit request is present.
15 to 0	TMTRSTSp	All 0	R	Transmit Buffer Transmit Request Status Flag p (p = y × 32 + 15 to y × 32 + 0) 0: No transmit request is present. 1: A transmit request is present.

TMTRSTSp Flags (p = 0 to 31)

These flags indicate the status of the TMTR bit in the RSCFDnCFDTMCP register.

When the TMTR bit is set to 1 (transmission is requested), the corresponding TMTRSTSp flag is set to 1.

The corresponding TMTRSTSp flag is cleared to 0 when the TMTR bit is set to 0 (transmission is not requested) or in channel reset mode.

Table 28.28 shows the bit assignment.

Table 28.28 TMTRSTSp Bit Assignment

Bit	Channel	Transmit Buffer Number
0	0	0
1	0	1
.	.	.
.	.	.
15	0	15
16	1	0
.	.	.
.	.	.
30	1	14
31	1	15

28.4.12.2 RSCFDnCFDTMTARSTSy — Transmit Buffer Transmit Abort Request Status Register (y = 0)

Access Size: RSCFDnCFDTMTARSTSy register can be read only in 32-bit units
RSCFDnCFDTMTARSTSyL, RSCFDnCFDTMTARSTSyH registers can be read only in 16-bit units
RSCFDnCFDTMTARSTSyLL, RSCFDnCFDTMTARSTSyLH, RSCFDnCFDTMTARSTSyHL,
RSCFDnCFDTMTARSTSyHH registers can be read only in 8-bit units

Address(es): RSCFDnCFDTMTARSTSy: <RSCFDn_base> + H'0360 + (H'04 × y)
RSCFDnCFDTMTARSTSyL: <RSCFDn_base> + H'0360 + (H'04 × y),
RSCFDnCFDTMTARSTSyH: <RSCFDn_base> + H'0362 + (H'04 × y)
RSCFDnCFDTMTARSTSyLL: <RSCFDn_base> + H'0360 + (H'04 × y),
RSCFDnCFDTMTARSTSyLH: <RSCFDn_base> + H'0361 + (H'04 × y),
RSCFDnCFDTMTARSTSyHL: <RSCFDn_base> + H'0362 + (H'04 × y),
RSCFDnCFDTMTARSTSyHH: <RSCFDn_base> + H'0363 + (H'04 × y)

Initial Value: H'0000 0001

Bit	31	30	29	28	27	26	25	24	23	22	21	20	19	18	17	16
	TMTARSTSp (p = y × 32 + 31 to y × 32 + 16 (y = 0))															
Initial Value	0	0	0	0	0	0	0	0	0	0	0	0	0	0	0	0
R/W	R	R	R	R	R	R	R	R	R	R	R	R	R	R	R	R
Bit	15	14	13	12	11	10	9	8	7	6	5	4	3	2	1	0
	TMTARSTSp (p = y × 32 + 15 to y × 32 + 0 (y = 0))															
Initial Value	0	0	0	0	0	0	0	0	0	0	0	0	0	0	0	0
R/W	R	R	R	R	R	R	R	R	R	R	R	R	R	R	R	R

Bit	Bit Name	Initial Value	R/W	Description
31 to 16	TMTARSTSp	All 0	R	Transmit Buffer Transmit Abort Request Status Flag p (p = y × 32 + 31 to y × 32 + 16) 0: No transmit abort request is present. 1: A transmit abort request is present.
15 to 0	TMTARSTSp	All 0	R	Transmit Buffer Transmit Abort Request Status Flag p (p = y × 32 + 15 to y × 32 + 0) 0: No transmit abort request is present. 1: A transmit abort request is present.

TMTARSTSp Flags (p = 0 to 31)

These flags indicate the status of the TMTAR bit in the RSCFDnCFDTMCp register.

When the TMTAR bit is set to 1 (transmit abort is requested), the corresponding TMTARSTSp flag is set to 1.

The corresponding TMTARSTSp flag is cleared to 0 when the TMTAR bit is set to 0 (transmit abort is not requested) or in channel reset mode.

Table 28.29 shows the bit assignment.

Table 28.29 TMTARSTSp Bit Assignment

Bit	Channel	Transmit Buffer Number
0	0	0
1	0	1
.	.	.
.	.	.
15	0	15
16	1	0
.	.	.
.	.	.
30	1	14
31	1	15

28.4.12.3 RSCFDnCFDTMTCSTSy — Transmit Buffer Transmit Complete Status Register (y = 0)

Access Size: RSCFDnCFDTMTCSTSy register can be read only in 32-bit units
 RSCFDnCFDTMTCSTSyL, RSCFDnCFDTMTCSTSyH registers can be read only in 16-bit units
 RSCFDnCFDTMTCSTSyLL, RSCFDnCFDTMTCSTSyLH, RSCFDnCFDTMTCSTSyHL,
 RSCFDnCFDTMTCSTSyHH registers can be read only in 8-bit units

Address(es): RSCFDnCFDTMTCSTSy: <RSCFDn_base> + H'0370 + (H'04 × y)
 RSCFDnCFDTMTCSTSyL: <RSCFDn_base> + H'0370 + (H'04 × y),
 RSCFDnCFDTMTCSTSyH: <RSCFDn_base> + H'0372 + (H'04 × y)
 RSCFDnCFDTMTCSTSyLL: <RSCFDn_base> + H'0370 + (H'04 × y),
 RSCFDnCFDTMTCSTSyLH: <RSCFDn_base> + H'0371 + (H'04 × y),
 RSCFDnCFDTMTCSTSyHL: <RSCFDn_base> + H'0372 + (H'04 × y),
 RSCFDnCFDTMTCSTSyHH: <RSCFDn_base> + H'0373 + (H'04 × y)

Initial Value: H'0000 0000

Bit	31	30	29	28	27	26	25	24	23	22	21	20	19	18	17	16
	TMTCSTSp (p = y × 32 + 31 to y × 32 + 16 (y = 0))															
Initial Value	0	0	0	0	0	0	0	0	0	0	0	0	0	0	0	0
R/W	R	R	R	R	R	R	R	R	R	R	R	R	R	R	R	R
Bit	15	14	13	12	11	10	9	8	7	6	5	4	3	2	1	0
	TMTCSTSp (p = y × 32 + 15 to y × 32 + 0 (y = 0))															
Initial Value	0	0	0	0	0	0	0	0	0	0	0	0	0	0	0	0
R/W	R	R	R	R	R	R	R	R	R	R	R	R	R	R	R	R

Bit	Bit Name	Initial Value	R/W	Description
31 to 16	TMTCSTSp	All 0	R	Transmit Buffer Transmit Complete Status Flag p (p = y × 32 + 31 to y × 32 + 16) 0: Transmission has not been completed. 1: Transmission has been completed.
15 to 0	TMTCSTSp	All 0	R	Transmit Buffer Transmit Complete Status Flag p (p = y × 32 + 15 to y × 32 + 0) 0: Transmission has not been completed. 1: Transmission has been completed.

TMTCSTSp Flags (p = 0 to 31)

When the TMTRF[1:0] flag in the RSCFDnCFDTMSTSp register is set to 10b (transmission has been completed (without transmit abort request)) or 11b (transmission has been completed (with transmit abort request)), the corresponding TMTCSTSp flag is set to 1.

A TMTCSTSp flag is cleared to 0 when the corresponding TMTRF[1:0] flag is set to 00b or in channel reset mode.

Table 28.30 shows the bit assignment.

Table 28.30 TMTCSSTp Bit Assignment

Bit	Channel	Transmit Buffer Number
0	0	0
1	0	1
.	.	.
.	.	.
15	0	15
16	1	0
.	.	.
.	.	.
30	1	14
31	1	15

28.4.12.4 RSCFDnCFDTMTASTSy — Transmit Buffer Transmit Abort Status Register (y = 0)

Access Size: RSCFDnCFDTMTASTSy register can be read only in 32-bit units
RSCFDnCFDTMTASTSyL, RSCFDnCFDTMTASTSyH registers can be read only in 16-bit units
RSCFDnCFDTMTASTSyLL, RSCFDnCFDTMTASTSyLH, RSCFDnCFDTMTASTSyHL,
RSCFDnCFDTMTASTSyHH registers can be read only in 8-bit units

Address(es): RSCFDnCFDTMTASTSy: <RSCFDn_base> + H'0380 + (H'04 × y)
RSCFDnCFDTMTASTSyL: <RSCFDn_base> + H'0380 + (H'04 × y),
RSCFDnCFDTMTASTSyH: <RSCFDn_base> + H'0382 + (H'04 × y)
RSCFDnCFDTMTASTSyLL: <RSCFDn_base> + H'0380 + (H'04 × y),
RSCFDnCFDTMTASTSyLH: <RSCFDn_base> + H'0381 + (H'04 × y),
RSCFDnCFDTMTASTSyHL: <RSCFDn_base> + H'0382 + (H'04 × y),
RSCFDnCFDTMTASTSyHH: <RSCFDn_base> + H'0383 + (H'04 × y)

Initial Value: H'0000 0000

Bit	31	30	29	28	27	26	25	24	23	22	21	20	19	18	17	16
	TMTASTSp (p = y × 32 + 31 to y × 32 + 16 (y = 0))															
Initial Value	0	0	0	0	0	0	0	0	0	0	0	0	0	0	0	0
R/W	R	R	R	R	R	R	R	R	R	R	R	R	R	R	R	R
Bit	15	14	13	12	11	10	9	8	7	6	5	4	3	2	1	0
	TMTASTSp (p = y × 32 + 15 to y × 32 + 0 (y = 0))															
Initial Value	0	0	0	0	0	0	0	0	0	0	0	0	0	0	0	0
R/W	R	R	R	R	R	R	R	R	R	R	R	R	R	R	R	R

Bit	Bit Name	Initial Value	R/W	Description
31 to 16	TMTASTSp	All 0	R	Transmit Buffer Transmit Abort Status Flag p (p = y × 32 + 31 to y × 32 + 16) 0: Transmission is not aborted 1: Transmission is aborted
15 to 0	TMTASTSp	All 0	R	Transmit Buffer Transmit Abort Status Flag p (p = y × 32 + 15 to y × 32 + 0) 0: Transmission is not aborted. 1: Transmission is aborted.

TMTASTSp Flags (p = 0 to 31)

When the TMTRF[1:0] flag in the RSCFDnCFDTMSTSp register is set to 01b (transmit abort has been completed), the corresponding TMTASTSp flag is set to 1.

A TMTASTSp flag is cleared to 0 when the corresponding TMTRF[1:0] flag is set to 00b or in channel reset mode.

Table 28.31 shows the bit assignment.

Table 28.31 TMTASTSp Bit Assignment

Bit	Channel	Transmit Buffer Number
0	0	0
1	0	1
.	.	.
.	.	.
15	0	15
16	1	0
.	.	.
.	.	.
30	1	14
31	1	15

28.4.13 Details of Transmit Queue-related Registers

28.4.13.1 RSCFDnCFDTXQCCm — Transmit Queue Configuration and Control Register (m = 0, 1)

Access Size: RSCFDnCFDTXQCCm register can be read/written in 32-bit units
 RSCFDnCFDTXQCCmL, RSCFDnCFDTXQCCmH registers can be read/written in 16-bit units
 RSCFDnCFDTXQCCmLL, RSCFDnCFDTXQCCmLH, RSCFDnCFDTXQCCmHL, RSCFDnCFDTXQCCmHH registers can be read/ written in 8-bit units

Address(es): RSCFDnCFDTXQCCm: <RSCFDn_base> + H'03A0 + (H'04 × m)
 RSCFDnCFDTXQCCmL: <RSCFDn_base> + H'03A0 + (H'04 × m),
 RSCFDnCFDTXQCCmH: <RSCFDn_base> + H'03A2 + (H'04 × m)
 RSCFDnCFDTXQCCmLL: <RSCFDn_base> + H'03A0 + (H'04 × m),
 RSCFDnCFDTXQCCmLH: <RSCFDn_base> + H'03A1 + (H'04 × m),
 RSCFDnCFDTXQCCmHL: <RSCFDn_base> + H'03A2 + (H'04 × m),
 RSCFDnCFDTXQCCmHH: <RSCFDn_base> + H'03A3 + (H'04 × m)

Initial Value: H'0000 0000

Bit	31	30	29	28	27	26	25	24	23	22	21	20	19	18	17	16
	—	—	—	—	—	—	—	—	—	—	—	—	—	—	—	—
Initial Value	0	0	0	0	0	0	0	0	0	0	0	0	0	0	0	0
R/W	R	R	R	R	R	R	R	R	R	R	R	R	R	R	R	R
Bit	15	14	13	12	11	10	9	8	7	6	5	4	3	2	1	0
	—	—	TXQIM	TXQIE	TXQDC[3:0]			—	—	—	—	—	—	—	—	TXQE
Initial Value	0	0	0	0	0	0	0	0	0	0	0	0	0	0	0	0
R/W	R	R	R/W	R/W	R/W	R/W	R/W	R/W	R	R	R	R	R	R	R	R/W

Bit	Bit Name	Initial Value	R/W	Description
31 to 14	—	All 0	R	Reserved These bits are read as the value after reset. The write value should be the value after reset.
13	TXQIM	0	R/W	Transmit Queue Interrupt Source Select 0: When the transmit queue becomes empty upon completion of message transmission, a transmit queue interrupt request is generated. 1: A transmit queue interrupt request is generated each time a message has been transmitted.
12	TXQIE	0	R/W	Transmit Queue Interrupt Enable 0: Transmit queue interrupt is disabled. 1: Transmit queue interrupt is enabled.
11 to 8	TXQDC[3:0]	All 0	R/W	Transmit Queue Depth Configuration Setting these bits to g (g = 2 to 15) makes the (g + 1)-buffer transmit queue available. Setting these bits to 0 disables the transmit queue. Setting these bits to 1 is prohibited. For transmit buffer merge mode, set g to 2 to 9.
7 to 1	—	All 0	R	Reserved These bits are read as the value after reset. The write value should be the value after reset.
0	TXQE	0	R/W	Transmit Queue Enable 0: The transmit queue is not used. 1: The transmit queue is used.

TXQIM Bit

This bit is used to select a transmit queue interrupt source. Modify this bit in channel reset mode.

TXQIE Bit

When the TXQIE bit is set to 1 and the source selected by the TXQIM bit occurs, an interrupt request is generated.

Set the TXQE bit to 0 before modifying the TXQIE bit.

TXQDC[3:0] Bits

These bits are used to specify the number of transmit buffers to be allocated to the transmit queues. Transmit buffers are allocated to transmit queues in descending order of buffer number, that is, from $(m \times 16 + 15)$ to $(m \times 16 + 0)$. For examples of how buffer allocation is done, see **Figure 28.9**.

When the TMME bit in the RSCFDnCFDCmFDCFG register is 1 (transmit buffer merge mode), transmit buffers $(m \times 16 + 5)$ to $(m \times 16 + 0)$ are merged and cannot be allocated to the transmit queue. Therefore, do not set TXQDC[3:0] bits to 10 to 15.

Modify these bits only in channel reset mode.

TXQE Bit

Setting this bit to 1 makes the transmit queue available. Modify this bit in channel communication mode or channel halt mode. This bit is cleared to 0 in channel reset mode.

Before setting the TXQE bit to 1, set the TXQDC[3:0] bits to 0010b or more.

28.4.13.2 RSCFDnCFDTXQSTSm — Transmit Queue Status Register (m = 0, 1)

Access Size: RSCFDnCFDTXQSTSm register can be read/written in 32-bit units
 RSCFDnCFDTXQSTSmL, RSCFDnCFDTXQSTSmH registers can be read/written in 16-bit units
 RSCFDnCFDTXQSTSmLL, RSCFDnCFDTXQSTSmLH, RSCFDnCFDTXQSTSmHL,
 RSCFDnCFDTXQSTSmHH registers can be read/written in 8-bit units

Address(es): RSCFDnCFDTXQSTSm: <RSCFDn_base> + H'03C0 + (H'04 × m)
 RSCFDnCFDTXQSTSmL: <RSCFDn_base> + H'03C0 + (H'04 × m),
 RSCFDnCFDTXQSTSmH: <RSCFDn_base> + H'03C2 + (H'04 × m)
 RSCFDnCFDTXQSTSmLL: <RSCFDn_base> + H'03C0 + (H'04 × m),
 RSCFDnCFDTXQSTSmLH: <RSCFDn_base> + H'03C1 + (H'04 × m),
 RSCFDnCFDTXQSTSmHL: <RSCFDn_base> + H'03C2 + (H'04 × m),
 RSCFDnCFDTXQSTSmHH: <RSCFDn_base> + H'03C3 + (H'04 × m)

Initial Value: H'0000 0001

Bit	31	30	29	28	27	26	25	24	23	22	21	20	19	18	17	16
	—	—	—	—	—	—	—	—	—	—	—	—	—	—	—	—
Initial Value	0	0	0	0	0	0	0	0	0	0	0	0	0	0	0	0
R/W	R	R	R	R	R	R	R	R	R	R	R	R	R	R	R	R
Bit	15	14	13	12	11	10	9	8	7	6	5	4	3	2	1	0
	—	—	—	—	—	—	—	—	—	—	—	—	—	TXQIF	TXQFLL	TXQEMP
Initial Value	0	0	0	0	0	0	0	0	0	0	0	0	0	0	0	1
R/W	R	R	R	R	R	R	R	R	R	R	R	R	R	R/W*1	R	R

Bit	Bit Name	Initial Value	R/W	Description
31 to 13	—	All 0	R	Reserved When read, the value after reset is returned. When writing to these bits, write the value after reset.
12 to 8	—	All 0	R	Reserved When read, the undefined value is returned. When writing to these bits, write the value after reset.
7 to 3	—	All 0	R	Reserved When read, the value after reset is returned. When writing to these bits, write the value after reset.
2	TXQIF	0	R/W*1	Transmit Queue Interrupt Request Flag 0: No transmit queue interrupt request is present. 1: A transmit queue interrupt request is present.
1	TXQFLL	0	R	Transmit Queue Full Status Flag 0: The transmit queue is not full. 1: The transmit queue is full.
0	TXQEMP	1	R	Transmit Queue Empty Status Flag 0: The transmit queue contains messages. 1: The transmit queue contains no message (transmit queue empty).

Note 1. The only effective value for writing to this flag bit is 0, which clears the bit. Otherwise writing to the bit results in retention of its state.

TXQIF Flag

The TXQIF flag is set to 1 when the event specified by the TXQIM bit in the RSCFDnCFDTXQCCm register has occurred.

The TXQIF flag is cleared to 0 in channel reset mode or by writing 0 to this flag. This flag is not cleared to 0 by setting the TXQE bit in the RSCFDnCFDTXQCCm register to 0 (the transmit queue is not used).

TXQFLL Flag

The TXQFLL flag is set to 1 when the number of messages set for the transmit queue matches the transmit queue depth set by the TXQDC[3:0] bits in the RSCFDnCFDTXQCCm register.

This flag is cleared to 0 in any of the following cases.

- The number of messages set for the transmit queue is smaller than the transmit queue depth set by the TXQDC[3:0] bits.
- In channel reset mode

TXQEMP Flag

The TXQEMP flag is cleared to 0 when even a single message is set for the transmit queue.

This flag is set to 1 in any of the following cases.

- The TXQE bit is set to 0 (the transmit queue is not used).
- The transmit queue becomes empty.
- In channel reset mode

28.4.13.3 RSCFDnCFDTXQPCTm — Transmit Queue Pointer Control Register (m = 0, 1)

Access Size: RSCFDnCFDTXQPCTm register can only be written in 32-bit units
 RSCFDnCFDTXQPCTmL, RSCFDnCFDTXQPCTmH registers can only be written in 16-bit units
 RSCFDnCFDTXQPCTmLL, RSCFDnCFDTXQPCTmLH, RSCFDnCFDTXQPCTmHL,
 RSCFDnCFDTXQPCTmHH registers can only be written in 8-bit units

Address(es): RSCFDnCFDTXQPCTm: <RSCFDn_base> + H'03E0 + (H'04 × m)
 RSCFDnCFDTXQPCTmL: <RSCFDn_base> + H'03E0 + (H'04 × m),
 RSCFDnCFDTXQPCTmH: <RSCFDn_base> + H'03E2 + (H'04 × m)
 RSCFDnCFDTXQPCTmLL: <RSCFDn_base> + H'03E0 + (H'04 × m),
 RSCFDnCFDTXQPCTmLH: <RSCFDn_base> + H'03E1 + (H'04 × m),
 RSCFDnCFDTXQPCTmHL: <RSCFDn_base> + H'03E2 + (H'04 × m),
 RSCFDnCFDTXQPCTmHH: <RSCFDn_base> + H'03E3 + (H'04 × m)

Initial Value: H'0000 0000

Bit	31	30	29	28	27	26	25	24	23	22	21	20	19	18	17	16
	—	—	—	—	—	—	—	—	—	—	—	—	—	—	—	—
Initial Value	0	0	0	0	0	0	0	0	0	0	0	0	0	0	0	0
R/W	R	R	R	R	R	R	R	R	R	R	R	R	R	R	R	R
Bit	15	14	13	12	11	10	9	8	7	6	5	4	3	2	1	0
	—	—	—	—	—	—	—	—	TXQPC[7:0]							
Initial Value	0	0	0	0	0	0	0	0	0	0	0	0	0	0	0	0
R/W	R	R	R	R	R	R	R	R	W	W	W	W	W	W	W	W

Bit	Bit Name	Initial Value	R/W	Description
31 to 8	—	All 0	R	Reserved The write value should be the value after reset.
7 to 0	TXQPC[7:0]	All 0	W	Transmit Queue Pointer Control Writing H'FF to these bits moves the write pointer of the transmit queue to the next queue buffer.

TXQPC[7:0] Bits

Writing H'FF to the TXQPC[7:0] bits moves the write pointer to the next transmit queue buffer and generates a transmit request of the message. Write transmit messages to the RSCFDnCFDTMIDp, RSCFDnCFDTMPTRp, RSCFDnCFDTMFDCTRp, and RSCFDnCFDTMDFb_p registers (p = 15 and 31) before writing H'FF to the TXQPC[7:0] bits.

When writing H'FF to these bits, make sure that the TXQE bit in the RSCFDnCFDTXQCCm register is set to 1 (the transmit queue is used) and the TXQFLL flag in the RSCFDnCFDTXQSTSm register is 0 (the transmit queue is not full).

28.4.14 Details of Transmit History-related Registers

28.4.14.1 RSCFDnCFDTHLCCm — Transmit History Configuration and Control Register (m = 0, 1)

Access Size: RSCFDnCFDTHLCCm register can be read/written in 32-bit units
 RSCFDnCFDTHLCCmL, RSCFDnCFDTHLCCmH registers can be read/written in 16-bit units
 RSCFDnCFDTHLCCmLL, RSCFDnCFDTHLCCmLH, RSCFDnCFDTHLCCmHL, RSCFDnCFDTHLCCmHH registers can be read/written in 8-bit units

Address(es): RSCFDnCFDTHLCCm: <RSCFDn_base> + H'0400 + (H'04 × m)
 RSCFDnCFDTHLCCmL: <RSCFDn_base> + H'0400 + (H'04 × m),
 RSCFDnCFDTHLCCmH: <RSCFDn_base> + H'0402 + (H'04 × m)
 RSCFDnCFDTHLCCmLL: <RSCFDn_base> + H'0400 + (H'04 × m),
 RSCFDnCFDTHLCCmLH: <RSCFDn_base> + H'0401 + (H'04 × m),
 RSCFDnCFDTHLCCmHL: <RSCFDn_base> + H'0402 + (H'04 × m),
 RSCFDnCFDTHLCCmHH: <RSCFDn_base> + H'0403 + (H'04 × m)

Initial Value: H'0000 0000

Bit	31	30	29	28	27	26	25	24	23	22	21	20	19	18	17	16
	—	—	—	—	—	—	—	—	—	—	—	—	—	—	—	—
Initial Value	0	0	0	0	0	0	0	0	0	0	0	0	0	0	0	0
R/W	R	R	R	R	R	R	R	R	R	R	R	R	R	R	R	R
Bit	15	14	13	12	11	10	9	8	7	6	5	4	3	2	1	0
	—	—	—	—	—	THLDT E	THLIM	THLIE	—	—	—	—	—	—	—	THLE
Initial Value	0	0	0	0	0	0	0	0	0	0	0	0	0	0	0	0
R/W	R	R	R	R	R	R/W	R/W	R/W	R	R	R	R	R	R	R	R/W

Bit	Bit Name	Initial Value	R/W	Description
31 to 11	—	All 0	R	Reserved When read, the value after reset is returned. When writing to these bits, write the value after reset.
10	THLDTE	0	R/W	Transmit History Target Buffer Select 0: Entry from transmit/receive FIFO buffers and transmit queue 1: Entry from transmit buffers, transmit/receive FIFO buffers, and transmit queue
9	THLIM	0	R/W	Transmit History Interrupt Source Select 0: When 12 sets of data have been stored in the transmit history buffer 1: When a single set of transmit history data has been stored
8	THLIE	0	R/W	Transmit History Interrupt Enable 0: Transmit history interrupt is disabled. 1: Transmit history interrupt is enabled.
7 to 1	—	All 0	R	Reserved When read, the value after reset is returned. When writing to these bits, write the value after reset.
0	THLE	0	R/W	Transmit History Buffer Enable 0: Transmit history buffer is not used. 1: Transmit history buffer is used.

THLDTE Bit

When this bit is set to 0, the transmit history data of messages transmitted from transmit/receive FIFO buffers and the transmit queue is stored in the transmit history buffer. When this bit is set to 1, the transmit history data of messages transmitted from transmit buffers, transmit/receive FIFO buffers, and the transmit queue is stored in the transmit history buffer.

Modify this bit only in channel reset mode.

THLIM Bit

This bit is used to select a transmit history interrupt source.

Modify this bit only in channel reset mode.

THLIE Bit

When the THLIE bit is set to 1 and the source selected by the THLIM bit has occurred, a transmit history interrupt request is generated. Modify the THLIE bit only when the THLE bit set to 0.

THLE Bit

Setting this bit to 1 makes the transmit history buffer available. When data transmission from the buffer selected by the THLDTE bit has been completed, the transmit history data of transmit messages is stored in the transmit history buffer.

Modify this bit in channel communication mode or channel halt mode.

This bit is cleared to 0 in channel reset mode.

28.4.14.2 RSCFDnCFDTHLSTSm — Transmit History Status Register (m = 0, 1)

Access Size: RSCFDnCFDTHLSTSm register can be read/written in 32-bit units
 RSCFDnCFDTHLSTSmL, RSCFDnCFDTHLSTSmH registers can be read/written in 16-bit units
 RSCFDnCFDTHLSTSmLL, RSCFDnCFDTHLSTSmLH, RSCFDnCFDTHLSTSmHL, RSCFDnCFDTHLSTSmHH registers can be read/written in 8-bit units

Address(es): RSCFDnCFDTHLSTSm: <RSCFDn_base> + H'0420 + (H'04 × m)
 RSCFDnCFDTHLSTSmL: <RSCFDn_base> + H'0420 + (H'04 × m),
 RSCFDnCFDTHLSTSmH: <RSCFDn_base> + H'0422 + (H'04 × m)
 RSCFDnCFDTHLSTSmLL: <RSCFDn_base> + H'0420 + (H'04 × m),
 RSCFDnCFDTHLSTSmLH: <RSCFDn_base> + H'0421 + (H'04 × m),
 RSCFDnCFDTHLSTSmHL: <RSCFDn_base> + H'0422 + (H'04 × m),
 RSCFDnCFDTHLSTSmHH: <RSCFDn_base> + H'0423 + (H'04 × m)

Initial Value: H'0000 0001

Bit	31	30	29	28	27	26	25	24	23	22	21	20	19	18	17	16
	—	—	—	—	—	—	—	—	—	—	—	—	—	—	—	—
Initial Value	0	0	0	0	0	0	0	0	0	0	0	0	0	0	0	0
R/W	R	R	R	R	R	R	R	R	R	R	R	R	R	R	R	R
Bit	15	14	13	12	11	10	9	8	7	6	5	4	3	2	1	0
	—	—	—	THLMC[4:0]				—	—	—	—	THLIF	THLELT	THLFLL	THLEMP	
Initial Value	0	0	0	0	0	0	0	0	0	0	0	0	0	0	0	1
R/W	R	R	R	R	R	R	R	R	R	R	R	R	R/W*1	R/W*1	R	R

Bit	Bit Name	Initial Value	R/W	Description
31 to 13	—	All 0	R	Reserved These bits are read as the value after reset. The write value should be the value after reset.
12 to 8	THLMC[4:0]	All 0	R	Transmit History Buffer Unread Data Counter These bits indicate the number of unread data sets stored in the transmit history buffer.
7 to 4	—	All 0	R	Reserved These bits are read as the value after reset. The write value should be the value after reset.
3	THLIF	0	R/W*1	Transmit History Interrupt Request Flag 0: No transmit history interrupt request is present. 1: A transmit history interrupt request is present.
2	THLELT	0	R/W*1	Transmit History Buffer Overflow Flag 0: Transmit history buffer overflow has not occurred. 1: Transmit history buffer overflow has occurred.
1	THLFLL	0	R	Transmit history Buffer Full Status Flag 0: Transmit history buffer is not full. 1: Transmit history buffer is full.
0	THLEMP	1	R	Transmit History Buffer Empty Status Flag 0: Transmit history buffer contains unread data. 1: Transmit history buffer contains no unread data (buffer empty).

Note 1. The only effective value for writing to this flag bit is 0, which clears the bit. Otherwise writing to the bit results in retention of its state

THLMC[4:0] Bits

These bits indicate the number of unread data sets stored in the transmit history buffer. These bits are cleared to 0 in channel reset mode.

THLIF Flag

The THLIF flag is set to 1 when the interrupt source specified with the THLIM bit in the RSCFDnCFDTHLCCm register occurs.

This flag is cleared to 0 in channel reset mode or by the program writing 0 to this flag.

To clear the flags of the register to 0, the program must write 0 to the corresponding flag to be cleared.

When writing 0, using store instruction, set the bit to be set to “0” to “0”, and the bits not to be set to “0” to “1”.

THLELT Flag

The THLELT flag is set to 1 when an attempt is made to store new transmit history data while the transmit history buffer is full. In this case, the new data is discarded. This flag becomes 0 in channel reset mode or by the program writing 0 to this flag.

To clear the flags of the register to 0, the program must write 0 to the corresponding flag to be cleared.

When writing 0, using store instruction, set the bit to be set to “0” to “0”, and the bits not to be set to “0” to “1”.

THLFLL Flag

The THLFLL flag is set to 1 when 16 data sets have been stored in the transmit history buffer, and is cleared to 0 when the number of data sets stored in the transmit history buffer has decreased to less than 16. This bit is also cleared to 0 in channel reset mode or when the THLE bit in the RSCFDnCFDTHLCCm register is set to 0 (transmit history buffer is not used).

THLEMP Flag

The THLEMP flag is cleared to 0 when even a single set of transmit history data has been stored in the transmit history buffer.

This flag is set to 1 when all the data in the transmit history buffer has been read. This flag is also set to 1 in channel reset mode or when the THLE bit in the RSCFDnCFDTHLCCm register is set to 0 (transmit history buffer is not used).

NOTE

To clear THLIF or THLELT flag to 0, the program must write 0. When writing, use a store instruction to write “0” to the given flag and “1” to other flags.

28.4.14.3 RSCFDnCFDTHLPCTRm — Transmit History Pointer Control Register (m = 0, 1)

Access Size: RSCFDnCFDTHLPCTRm register can only be written in 32-bit units
 RSCFDnCFDTHLPCTRmL, RSCFDnCFDTHLPCTRmH registers can only be written in 16-bit units
 RSCFDnCFDTHLPCTRmLL, RSCFDnCFDTHLPCTRmLH, RSCFDnCFDTHLPCTRmHL,
 RSCFDnCFDTHLPCTRmHH registers can only be written in 8-bit units

Address(es): RSCFDnCFDTHLPCTRm: <RSCFDn_base> + H'0440 + (H'04 × m)
 RSCFDnCFDTHLPCTRmL: <RSCFDn_base> + H'0440 + (H'04 × m),
 RSCFDnCFDTHLPCTRmH: <RSCFDn_base> + H'0442 + (H'04 × m)
 RSCFDnCFDTHLPCTRmLL: <RSCFDn_base> + H'0440 + (H'04 × m),
 RSCFDnCFDTHLPCTRmLH: <RSCFDn_base> + H'0441 + (H'04 × m),
 RSCFDnCFDTHLPCTRmHL: <RSCFDn_base> + H'0442 + (H'04 × m),
 RSCFDnCFDTHLPCTRmHH: <RSCFDn_base> + H'0443 + (H'04 × m)

Initial Value: H'0000 0000

Bit	31	30	29	28	27	26	25	24	23	22	21	20	19	18	17	16
	—	—	—	—	—	—	—	—	—	—	—	—	—	—	—	—
Initial Value	0	0	0	0	0	0	0	0	0	0	0	0	0	0	0	0
R/W	R	R	R	R	R	R	R	R	R	R	R	R	R	R	R	R
Bit	15	14	13	12	11	10	9	8	7	6	5	4	3	2	1	0
	—	—	—	—	—	—	—	—	THLPC[7:0]							
Initial Value	0	0	0	0	0	0	0	0	0	0	0	0	0	0	0	0
R/W	R	R	R	R	R	R	R	R	W	W	W	W	W	W	W	W

Bit	Bit Name	Initial Value	R/W	Description
31 to 8	—	All 0	R	Reserved When writing to these bits, write the value after reset.
7 to 0	THLPC[7:0]	All 0	W	Transmit History List Pointer Control Writing H'FF to these bits moves the read pointer to the next unread data in the transmit history buffer.

THLPC[7:0] Bits

When the THLPC[7:0] bits are set to H'FF, the read pointer moves to the next data in the transmit history buffer. At this time, the THLMC[4:0] (transmit history buffer unread data counter) value in the RSCFDnCFDTHLSTSm register is decremented. Write H'FF to the THLPC[7:0] bits after reading from the RSCFDnCFDTHLACCm register.

When writing H'FF to these bits, make sure that the THLE bit in the RSCFDnCFDTHLCCm register is set to 1 (transmit history buffer is used) and the THLEMP flag in the RSCFDnCFDTHLSTSm register is 0.

28.4.14.4 RSCFDnCFDTHLACCm — Transmit History Access Register (m = 0, 1)

Access Size: RSCFDnCFDTHLACCm register can be read only in 32-bit units
RSCFDnCFDTHLACCmL, RSCFDnCFDTHLACCmH registers can be read only in 16-bit units
RSCFDnCFDTHLACCmLL, RSCFDnCFDTHLACCmLH, RSCFDnCFDTHLACCmHL,
RSCFDnCFDTHLACCmHH registers can be read only in 8-bit units

Address(es): RSCFDnCFDTHLACCm: <RSCFDn_base> + H'6000 + (H'04 × m)
RSCFDnCFDTHLACCmL: <RSCFDn_base> + H'6000 + (H'04 × m),
RSCFDnCFDTHLACCmH: <RSCFDn_base> + H'6002 + (H'04 × m)
RSCFDnCFDTHLACCmLL: <RSCFDn_base> + H'6000 + (H'04 × m),
RSCFDnCFDTHLACCmLH: <RSCFDn_base> + H'6001 + (H'04 × m),
RSCFDnCFDTHLACCmHL: <RSCFDn_base> + H'6002 + (H'04 × m),
RSCFDnCFDTHLACCmHH: <RSCFDn_base> + H'6003 + (H'04 × m)

Initial Value: H'0000 0000

Bit	31	30	29	28	27	26	25	24	23	22	21	20	19	18	17	16
	TMTS[15:0]															
Initial Value	0	0	0	0	0	0	0	0	0	0	0	0	0	0	0	0
R/W	R	R	R	R	R	R	R	R	R	R	R	R	R	R	R	R
Bit	15	14	13	12	11	10	9	8	7	6	5	4	3	2	1	0
	TID[7:0]							—	BN[3:0]			BT[2:0]				
Initial Value	0	0	0	0	0	0	0	0	0	0	0	0	0	0	0	0
R/W	R	R	R	R	R	R	R	R	R	R	R	R	R	R	R	R

Bit	Bit Name	Initial Value	R/W	Description																
31 to 16	TMTS[15:0]	All 0	R	Timestamp Data The timestamp data of stored data can be read.																
15 to 8	TID[7:0]	All 0	R	Label Data The label information of stored data can be read.																
7	—	All 0	R	Reserved This bit is read as the value after reset.																
6 to 3	BN[3:0]	All 0	R	Buffer Number Data The buffer number of transmit source (transmit buffer, transmit/receive FIFO or transmit queue) can be read.																
2 to 0	BT[2:0]	All 0	R	Buffer Type Data <table border="0" style="margin-left: 20px;"> <tr> <td>b2</td><td>b1</td><td>b0</td><td></td> </tr> <tr> <td>0</td><td>0</td><td>1</td><td>Transmit buffer</td> </tr> <tr> <td>0</td><td>1</td><td>0</td><td>Transmit/receive FIFO buffer</td> </tr> <tr> <td>1</td><td>0</td><td>0</td><td>Transmit queue</td> </tr> </table>	b2	b1	b0		0	0	1	Transmit buffer	0	1	0	Transmit/receive FIFO buffer	1	0	0	Transmit queue
b2	b1	b0																		
0	0	1	Transmit buffer																	
0	1	0	Transmit/receive FIFO buffer																	
1	0	0	Transmit queue																	

TMTS[15:0] Bits

Timestamp values in transmit history data stored in the transmit history buffer are displayed.

TID[7:0] Bits

These bits indicate the label information of transmit history data stored in the transmit history buffer.

BN[3:0] Bits

These bits indicate the transmit source buffer number in the transmit history data stored in the transmit history buffer.

BT[2:0] Bits

These bits indicate the type of the transmit source buffer in the transmit history data stored in the transmit history buffer.

28.4.15 Details of Test-related Registers

28.4.15.1 RSCFDnCFDGTSTCFG — Global Test Configuration Register

Access Size: RSCFDnCFDGTSTCFG register can be read/written in 32-bit units
 RSCFDnCFDGTSTCFG, RSCFDnCFDGTSTCFGH registers can be read/written in 16-bit units
 RSCFDnCFDGTSTCFG, RSCFDnCFDGTSTCFGH, RSCFDnCFDGTSTCFGH, RSCFDnCFDGTSTCFGH registers can be read/written in 8-bit units

Address(es): RSCFDnCFDGTSTCFG: <RSCFDn_base> + H'0468
 RSCFDnCFDGTSTCFG: <RSCFDn_base> + H'0468, RSCFDnCFDGTSTCFGH: <RSCFDn_base> + H'046A
 RSCFDnCFDGTSTCFG: <RSCFDn_base> + H'0468, RSCFDnCFDGTSTCFGH: <RSCFDn_base> + H'0469,
 RSCFDnCFDGTSTCFGH: <RSCFDn_base> + H'046A, RSCFDnCFDGTSTCFGH: <RSCFDn_base> + H'046B

Initial Value: H'0000 0000

Bit	31	30	29	28	27	26	25	24	23	22	21	20	19	18	17	16
	—									RTMPS[6:0]						
Initial Value	0	0	0	0	0	0	0	0	0	0	0	0	0	0	0	0
R/W	R	R	R	R	R	R	R	R	R	R/W	R/W	R/W	R/W	R/W	R/W	R/W
Bit	15	14	13	12	11	10	9	8	7	6	5	4	3	2	1	0
	—														C11CBCE	C01CBCE
Initial Value	0	0	0	0	0	0	0	0	0	0	0	0	0	0	0	0
R/W	R	R	R	R	R	R	R	R	R	R	R	R	R	R	R/W	R/W

Bit	Bit Name	Initial Value	R/W	Description
31 to 23	—	All 0	R	Reserved These bits are read as the value after reset. The write value should be the value after reset.
22 to 16	RTMPS[6:0]	All 0	R/W	RAM Test Page Configuration Set a value within a range of page 0 (H'00) to page 27 (H'1B).
15 to 2	—	All 0	R	Reserved These bits are read as the value after reset. The write value should be the value after reset.
1	C11CBCE	0	R/W	CAN1 Inter-Channel Communication Test Enable 0: CAN1 inter-channel communication test is disabled. 1: CAN1 inter-channel communication test is enabled.
0	C01CBCE	0	R/W	CAN0 Inter-Channel Communication Test Enable 0: CAN0 inter-channel communication test is disabled. 1: CAN0 inter-channel communication test is enabled.

Modify the RSCFDnCFDGTSTCFG register only in global test mode.

RTMPS[6:0] Bits

These bits are used to set the RAM test target page number for RAM test. Set a value in the range of H'00 to H'1B, inclusive. Do not access the RAM area higher than the 192th byte on the last page (the setting of the RTMPS bit is H'1B).

C1ICBCE Bit

Setting this bit to 1 enables the channel 1 inter-channel communication test.

This bit is cleared to 0 in global reset mode.

C0ICBCE Bit

Setting this bit to 1 enables the channel 0 inter-channel communication test.

This bit is cleared to 0 in global reset mode.

28.4.15.2 RSCFDnCFDGTSTCTR — Global Test Control Register

Access Size: RSCFDnCFDGTSTCTR register can be read/written in 32-bit units
 RSCFDnCFDGTSTCTRL, RSCFDnCFDGTSTCTRH registers can be read/written in 16-bit units
 RSCFDnCFDGTSTCTRL, RSCFDnCFDGTSTCTRLH, RSCFDnCFDGTSTCTRHL, RSCFDnCFDGTSTCTRHH registers can be read/written in 8-bit units

Address(es): RSCFDnCFDGTSTCTR: <RSCFDn_base> + H'046C
 RSCFDnCFDGTSTCTRL: <RSCFDn_base> + H'046C, RSCFDnCFDGTSTCTRH: <RSCFDn_base> + H'046E
 RSCFDnCFDGTSTCTRL: <RSCFDn_base> + H'046C, RSCFDnCFDGTSTCTRLH: <RSCFDn_base> + H'046D,
 RSCFDnCFDGTSTCTRHL: <RSCFDn_base> + H'046E, RSCFDnCFDGTSTCTRHH: <RSCFDn_base> + H'046F

Initial Value: H'0000 0000

Bit	31	30	29	28	27	26	25	24	23	22	21	20	19	18	17	16
	—	—	—	—	—	—	—	—	—	—	—	—	—	—	—	—
Initial Value	0	0	0	0	0	0	0	0	0	0	0	0	0	0	0	0
R/W	R	R	R	R	R	R	R	R	R	R	R	R	R	R	R	R
Bit	15	14	13	12	11	10	9	8	7	6	5	4	3	2	1	0
	—	—	—	—	—	—	—	—	—	—	—	—	—	RTME	—	ICBCTME
Initial Value	0	0	0	0	0	0	0	0	0	0	0	0	0	0	0	0
R/W	R	R	R	R	R	R	R	R	R	R	R	R	R	R/W	R	R/W

Bit	Bit Name	Initial Value	R/W	Description
31 to 3	—	All 0	R	Reserved These bits are read as the value after reset. The write value should be the value after reset.
2	RTME	0	R/W	RAM Test Enable 0: RAM test is disabled. 1: RAM test is enabled.
1	—	0	R	Reserved This bit is read as the value after reset. The write value should be the value after reset.
0	ICBCTME	0	R/W	Communication Test between Channels Enable 0: Communication test between channels disabled 1: Communication test between channels enabled

RTME Bit

Setting this bit to 1 enables the RAM test. Modify this bit only in global test mode. This bit is cleared to 0 in global reset mode.

1. Set the GMDC[1:0] bits in the RSCFDnCFDGTCTR register to 10b (Global test mode).
2. Set the RTME bit to 1.
3. Check that the RTME bit is set to 1.

ICBCTME Bit

When this bit is set to 1, a communication test is enabled between the channels for which the CmICBCE bit ($m = 0, 1$) in the RSCFDnCFDGTSTCFG register has been set to 1. Modify the ICBCTME bit only in global test mode.

This bit is cleared to 0 in global reset mode.

28.4.15.3 RSCFDnCFDGLOCKK — Global Lock Key Register

Access Size: RSCFDnCFDGLOCKK register can only be written in 32-bit units

RSCFDnCFDGLOCKKL, RSCFDnCFDGLOCKKH registers can only be written in 16-bit units

Address(es): RSCFDnCFDGLOCKK: <RSCFDn_base> + H'047C

RSCFDnCFDGLOCKKL: <RSCFDn_base> + H'047C, RSCFDnCFDGLOCKKH: <RSCFDn_base> + H'047E

Initial Value: H'0000 0000

Bit	31	30	29	28	27	26	25	24	23	22	21	20	19	18	17	16
	—	—	—	—	—	—	—	—	—	—	—	—	—	—	—	—
Initial Value	0	0	0	0	0	0	0	0	0	0	0	0	0	0	0	0
R/W	R	R	R	R	R	R	R	R	R	R	R	R	R	R	R	R
Bit	15	14	13	12	11	10	9	8	7	6	5	4	3	2	1	0
	LOCK[15:0]															
Initial Value	0	0	0	0	0	0	0	0	0	0	0	0	0	0	0	0
R/W	W*1	W*1	W*1	W*1	W*1	W*1	W*1	W*1	W*1	W*1	W*1	W*1	W*1	W*1	W*1	W*1

Bit	Bit Name	Initial Value	R/W	Description
31 to 16	—	All 0	R	Reserved When writing these bits, write the value after reset.
15 to 0	LOCK[15:0]	All 0	W*1	Lock Key These bits are key bits to release protection of test mode.

Note 1. Writing to these bits is effective only when the RS-CANFD module is in global test mode.

The RSCFDnCFDGLOCKK register releases protection of special test bits and is write only.

For the protection release data, see **Section 28.11.4.2, Procedure for Releasing the Protection.**

LOCK[15:0] Bits

Writing the protection release data to the LOCK[15:0] bits in succession enables writing 1 to the RTME bit in the RSCFDnCFDGTSTCTR register.

After the protection has been released, writing to the I/O register area (<RSCFDn_base> + H'0000 to <RSCFDn_base> + H'05FF) of the CAN (except the RAM) enables the protection again.

Reading from the I/O register area of the CAN or reading from/writing to other areas does not enable the protection.

28.4.15.4 RSCFDnCFDRPGACCr — RAM Test Page Access Register (r = 0 to 63)

Access Size: RSCFDnCFDRPGACCr register can be read/written in 32-bit units
 RSCFDnCFDRPGACCrL, RSCFDnCFDRPGACCrH registers can be read/written in 16-bit units
 RSCFDnCFDRPGACCrLL, RSCFDnCFDRPGACCrLH, RSCFDnCFDRPGACCrHL, RSCFDnCFDRPGACCrHH registers can be read/written in 8-bit units

Address(es): RSCFDnCFDRPGACCr: <RSCFDn_base> + H'6400 + (H'04 × r)
 RSCFDnCFDRPGACCrL: <RSCFDn_base> + H'6400 + (H'04 × r),
 RSCFDnCFDRPGACCrH: <RSCFDn_base> + H'6402 + (H'04 × r)
 RSCFDnCFDRPGACCrLL: <RSCFDn_base> + H'6400 + (H'04 × r),
 RSCFDnCFDRPGACCrLH: <RSCFDn_base> + H'6401 + (H'04 × r),
 RSCFDnCFDRPGACCrHL: <RSCFDn_base> + H'6402 + (H'04 × r),
 RSCFDnCFDRPGACCrHH: <RSCFDn_base> + H'6403 + (H'04 × r)

Initial Value: H'0000 0000

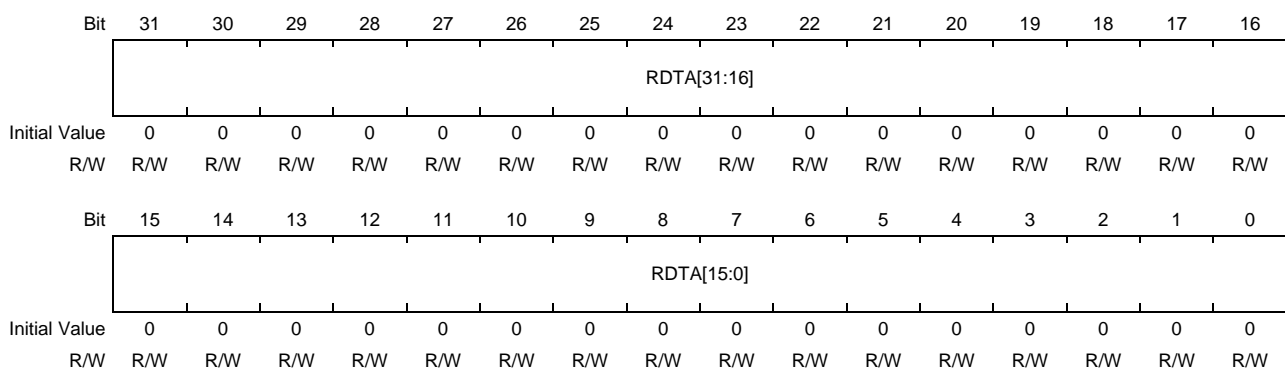

Bit	Bit Name	Initial Value	R/W	Description
31 to 0	RDTA[31:0]	All 0	R/W	RAM Data Test Access Data can be read and written in RSCAN RAM.

Modify the RSCFDnCFDRPGACCr register in global test mode with the RTME bit in the RSCFDnCFDGTSTCTR register set to 1 (RAM test is enabled).

The RSCFDnCFDRPGACCr register is readable and writable when the RTME bit is set to 1.

28.5 Interrupt Sources and DMA Trigger

28.5.1 Interrupt Sources

The RS-CANFD module has 8 interrupts that are grouped into global interrupts and channel interrupts.

- Global interrupts (2 sources):

Receive FIFO interrupt

Global error interrupt

- Channel interrupts (3 sources/channel):

CAN_m transmit interrupt (m = 0, 1)

– CAN_m transmit complete interrupt

– CAN_m transmit abort interrupt

– CAN_m transmit/receive FIFO transmit complete interrupt (in transmit mode, gateway mode)

– CAN_m transmit history interrupt

– CAN_m transmit queue Interrupt

CAN_m transmit/receive FIFO receive complete interrupt (in receive mode, gateway mode)

CAN_m error interrupt

When an interrupt request is generated, the corresponding interrupt request flag is set to 1 (interrupt request present). In that case, when the interrupt enable bit is set to 1 (enabling interrupts), an interrupt request is output from the RS-CANFD module. (Generation of interrupts also depends on the interrupt control register settings of the interrupt controller.)

Setting the interrupt request flag to 0 (no interrupt request present) or setting the interrupt enable bit to 0 (disabling interrupts) clears the current interrupt request. The current interrupt request is still output until the interrupt request flag is cleared.

Table 28.32 lists the CAN interrupt sources. **Figure 28.2** shows the CAN global interrupt block diagram. **Figure 28.3** shows the CAN channel interrupt block diagram.

Table 28.32 List of CAN Interrupt Sources (1/2)

RCAN				INTC	DMA	
	Interrupt Source (Unit Interrupt Signal)	Corresponding Interrupt Request Flag	Corresponding Interrupt Enable Bit	Request Source Name	Transfer Request Signal	
Global interrupts	Receive FIFO (INTRCAN GRECC)	Receive FIFO 0	RFIF in the RSCFDn(CFD)RFSTS0 register	RFIE in the RSCFDn(CFD)RFCC0 register	RFI	RXF_DMA0
		Receive FIFO 1	RFIF in the RSCFDn(CFD)RFSTS1 register	RFIE in the RSCFDn(CFD)RFCC1 register		RXF_DMA1
		Receive FIFO 2	RFIF in the RSCFDn(CFD)RFSTS2 register	RFIE in the RSCFDn(CFD)RFCC2 register		RXF_DMA2
		Receive FIFO 3	RFIF in the RSCFDn(CFD)RFSTS3 register	RFIE in the RSCFDn(CFD)RFCC3 register		RXF_DMA3
		Receive FIFO 4	RFIF in the RSCFDn(CFD)RFSTS4 register	RFIE in the RSCFDn(CFD)RFCC4 register		RXF_DMA4
		Receive FIFO 5	RFIF in the RSCFDn(CFD)RFSTS5 register	RFIE in the RSCFDn(CFD)RFCC5 register		RXF_DMA5
		Receive FIFO 6	RFIF in the RSCFDn(CFD)RFSTS6 register	RFIE in the RSCFDn(CFD)RFCC6 register		RXF_DMA6
		Receive FIFO 7	RFIF in the RSCFDn(CFD)RFSTS7 register	RFIE in the RSCFDn(CFD)RFCC7 register		RXF_DMA7
Global interrupts	Global error (INTRCANGERR)	<ul style="list-style-type: none"> DEF in the RSCFDn(CFD)GERFL register MES in the RSCFDn(CFD)GERFL register THLES in the RSCFDn(CFD)GERFL register CMPOF in the RSCFDnCFDGERFL register 	<ul style="list-style-type: none"> DEIE in the RSCFDn(CFD)GCTR register MEIE in the RSCFDn(CFD)GCTR register THLEIE in the RSCFDn(CFD)GCTR register CMPOFIE in the RSCFDnCFDGCTR register 	GERI	—	
Channel interrupts (m = 0, 1)	CANm transmit (INTRCAN mTRX)	CANm transmit complete	TMTRF[1:0] in the RSCFDn(CFD)TMSTSp register	TMIEp in the RSCFDn(CFD)TMIECy register	CTXIm	—
		CANm transmit abort	TMTRF[1:0] in the RSCFDn(CFD)TMSTSp register	TAIE in the RSCFDn(CFD)CmCTR register		—
		CANm transmit/receive FIFO transmit complete	CFTXIF in the RSCFDn(CFD)CFSTSk register	CFTXIE in the RSCFDn(CFD)CFCCk register		—
		CANm transmit queue	TXQIF in the RSCFDn(CFD)TXQSTSm register	TXQIE in the RSCFDn(CFD)TXQCCm register		—
		CANm transmit history	THLIF in the RSCFDn(CFD)THLSTSm register	THLIE in the RSCFDn(CFD)THLCCm register		—
	CANm transmit/receive FIFO receive complete (INTRCANmREC)	CFRXIF in the RSCFDn(CFD)CFSTSk register	CFRXIE in the RSCFDn(CFD)CFCCk register	CFRXIm	COM_DMAm	

Table 28.32 List of CAN Interrupt Sources (2/2)

RCAN				INTC	DMA
	Interrupt Source (Unit Interrupt Signal)	Corresponding Interrupt Request Flag	Corresponding Interrupt Enable Bit	Request Source Name	Transfer Request Signal
Channel interrupts (m = 0, 1)	CANm error (INTRCANmERR)	<ul style="list-style-type: none"> • BEF in the RSCFDn(CFD)CmERFL register • ALF in the RSCFDn(CFD)CmERFL register • BLF in the RSCFDn(CFD)CmERFL register • OVLf in the RSCFDn(CFD)CmERFL register • BORF in the RSCFDn(CFD)CmERFL register • BOEF in the RSCFDn(CFD)CmERFL register • EPF in the RSCFDn(CFD)CmERFL register • EWF in the RSCFDn(CFD)CmERFL register • SOCO in the RSCFDnCFDCmFDSTS register • EOCO in the RSCFDnCFDCmFDSTS register • TDCVF in the RSCFDnCFDCmFDSTS register 	<ul style="list-style-type: none"> • BEIE in the RSCFDn(CFD)CmCTR register • ALIE in the RSCFDn(CFD)CmCTR register • BLIE in the RSCFDn(CFD)CmCTR register • OLIE in the RSCFDn(CFD)CmCTR register • BORIE in the RSCFDn(CFD)CmCTR register • BOEIE in the RSCFDn(CFD)CmCTR register • EPIE in the RSCFDn(CFD)CmCTR register • EWIE in the RSCFDn(CFD)CmCTR register • SOCOIE in the RSCFDnCFDCmCTR register • EOCOIE in the RSCFDnCFDCmCTR register • TDCVFIE in the RSCFDnCFDCmCTR register 	CERIm	—

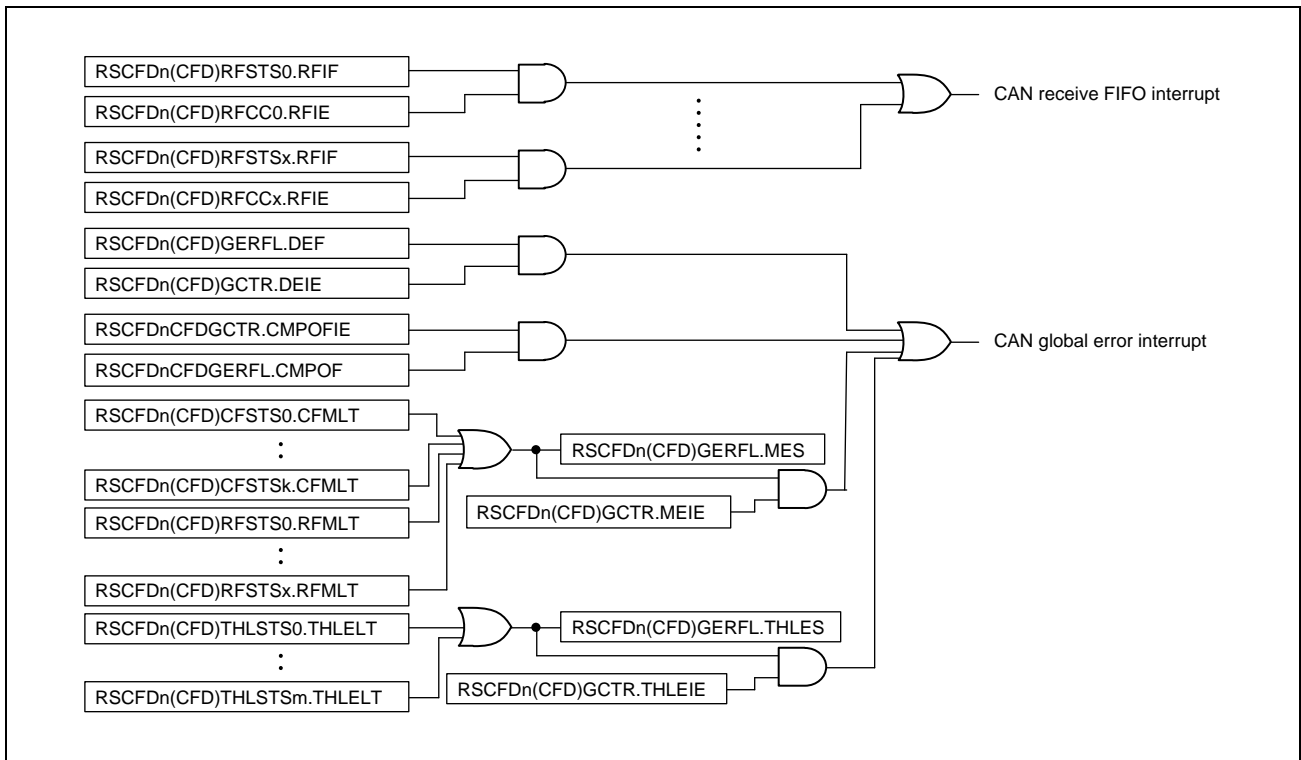

Figure 28.2 CAN Global Interrupt Block Diagram

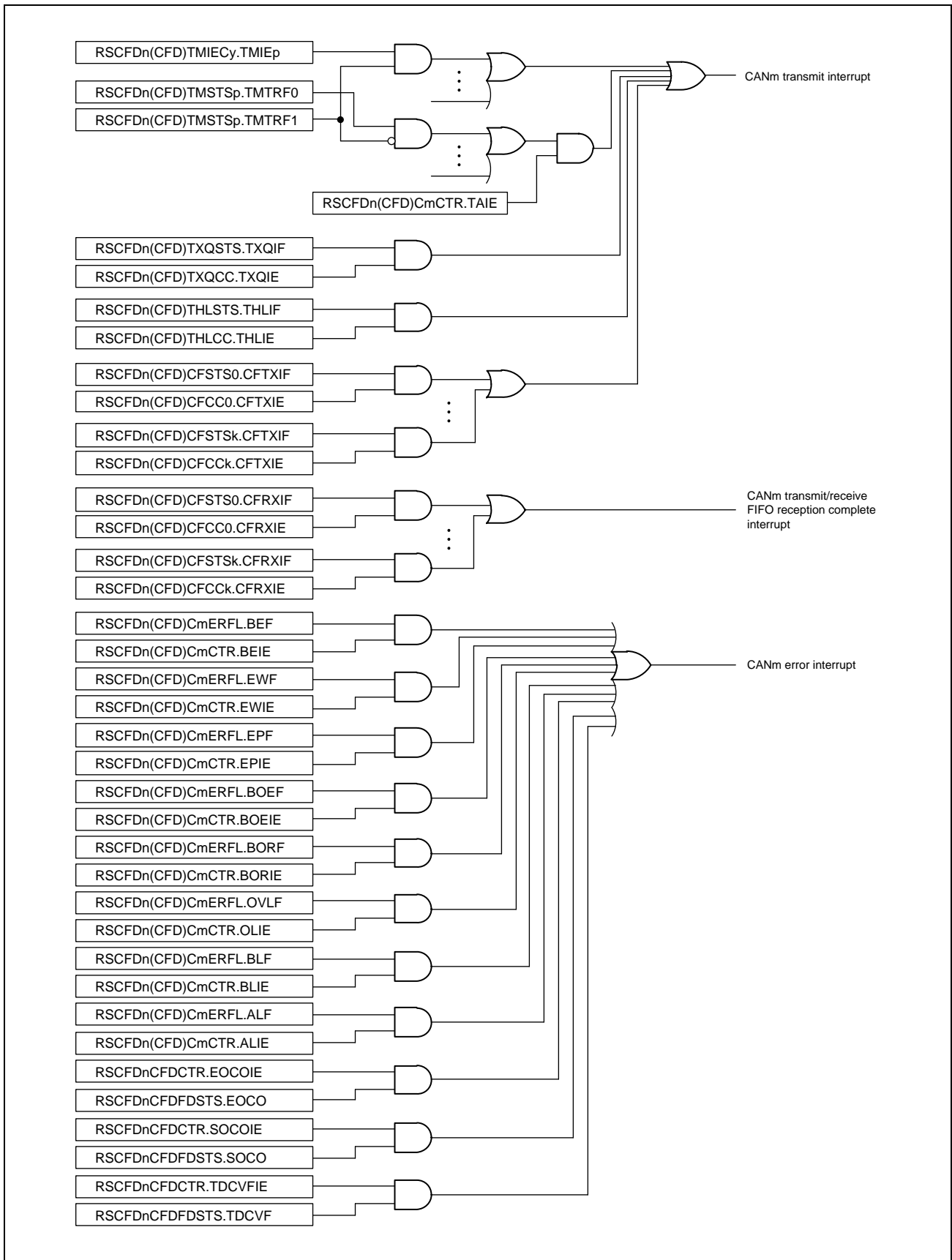

Figure 28.3 CAN Channel Interrupt Block Diagram

28.5.2 DMA Trigger (Only in CANFD Mode)

In CANFD mode, receive FIFO buffers can be related to DMA channels. The following 10 FIFO buffers can be related.

- All receive FIFO buffers x ($x = 0$ to 7)
- The first transmit/receive FIFO buffer k ($k = 3 \times m, m = 0, 1$) allocated to channel m

When the DMA enable bit (RFDMAEx or CFDMAEm bit in the RSCFDnCFDCDTCT register) is set to 1 and an unread message is remaining in the related FIFO, a DMA transfer request trigger is generated.

28.6 CAN Modes

The RS-CANFD module has four global modes to control the entire RS-CANFD module status and four channel modes to control individual channel status. Details of global modes are described in **Section 28.6.1, Global Modes**, and details of channel modes are described in **Section 28.6.2, Figure 28.5, Channel Mode State Transition Chart**.

- Global stop mode:Stops the clocks of the entire module to achieve low power consumption.
- Global reset mode:Performs initial settings for the entire module.
- Global test mode:Performs test settings and performs the RAM test.
- Global operating mode:Makes the entire module operable.
- Channel stop mode:Stops the channel clock.
- Channel reset mode:Performs initial settings for the channels.
- Channel halt mode:Stops CAN communication and allows channel testing.
- Channel communication mode:Performs CAN communication.

28.6.1 Global Modes

Figure 28.4 shows the transitions of global modes.

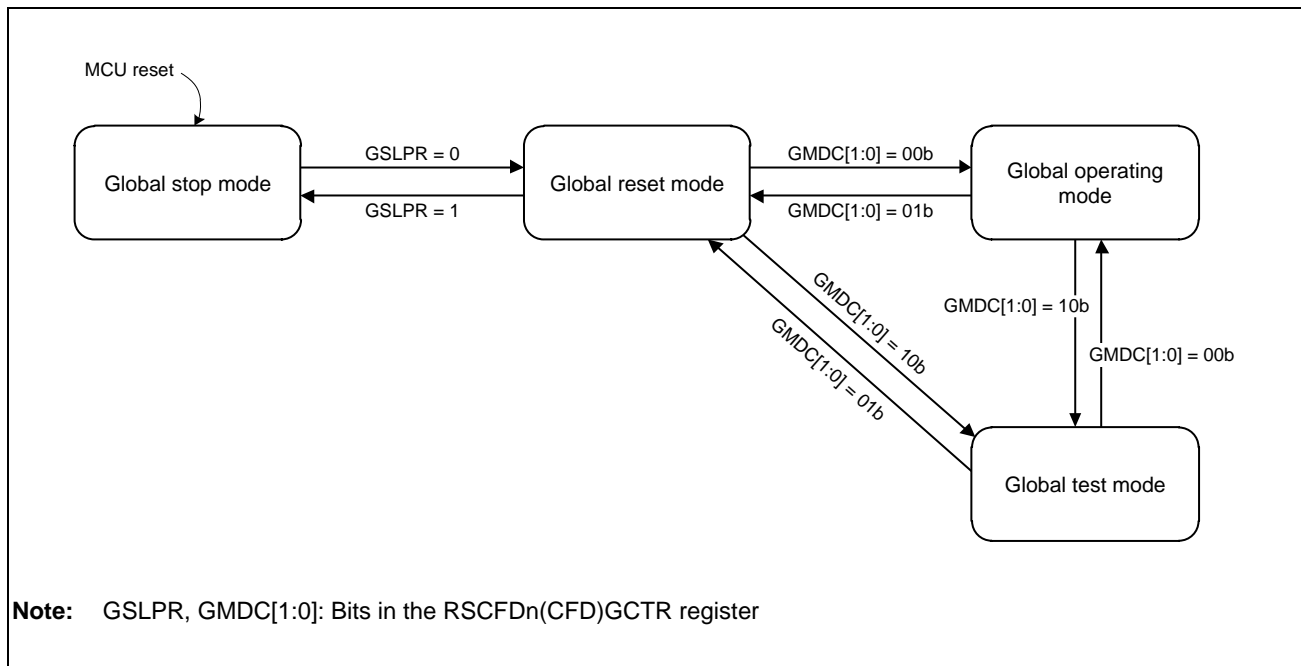

Figure 28.4 Transitions of Global Modes

In some cases, global mode transitions also force channel mode transitions. **Table 28.33** shows the channel mode transitions depending on the global mode setting dictated by the GMDC[1:0] bits and the GSLPR bit.

Table 28.33 Transitions of Channel Modes Depending on Global Mode Setting (GMDC[1:0] and GSLPR Bits)

Channel Mode before Setting	Channel Mode after Setting			
	GMDC[1:0] = 00b GSLPR = 0 (Global Operation)	GMDC[1:0] = 10b GSLPR = 0 (Global Test)	GMDC[1:0] = 01b GSLPR = 0 (Global Reset)	GMDC[1:0] = 01b GSLPR = 1 (Global Stop)
Channel communication	Channel communication	Channel halt	Channel reset	Transition prohibited
Channel halt	Channel halt	Channel halt	Channel reset	Transition prohibited
Channel reset	Channel reset	Channel reset	Channel reset	Channel stop
Channel stop	Channel stop	Channel stop	Channel stop	Channel stop

Note: GMDC[1:0], GSLPR: Bits in the RSCFDn(CFD)GCTR register

Table 28.34 shows the global mode transition time.

Table 28.34 Global Mode Transition Time

Mode before Transition	Mode after Transition	Maximum Transition Time
Global stop	Global reset	Three pclk cycles
Global reset	Global stop	Three pclk cycles
Global reset	Global test	Ten pclk cycles
Global reset	Global operating	Ten pclk cycles
Global test	Global reset	Two CAN bit times*1 *2
Global test	Global operating	Three pclk cycles
Global operating	Global reset	Two CAN bit times*1 *2
Global operating	Global test	Two CAN frames*1

Note 1. CAN frame time and CAN bit time of the lowest communication speed of the channels in use

Note 2. In CANFD mode, this time value is the CAN bit time of the nominal bit rate.

28.6.1.1 Global Stop Mode

In global stop mode, clocks of the CAN do not run and therefore power consumption is reduced. CAN registers can be read, but writing data to them is prohibited. Register values are retained. Only the clock used by the CPU for writing to the GSLPR bit runs in this mode.

After the MCU is reset, the CAN module transitions to global stop mode. Setting the GSLPR bit in the RSCFDn(CFD)GCTR register to 1 (in global stop mode) in global reset mode sets the CSLPR bit in each of the RSCFDn(CFD)CmCTR register to 1 (channel stop mode). Afterwards, if all channels are forced to transition to channel stop mode, the CAN module transitions to global stop mode. The GSLPR bit should not be modified in global operating mode or global test mode.

28.6.1.2 Global Reset Mode

In global reset mode, RS-CANFD module settings are performed. When the RS-CANFD module transitions to global reset mode, some registers are initialized. For registers to be initialized, see **Table 28.37, Registers Initialized in Global Reset Mode or Channel Reset Mode** and **Table 28.38, Registers Initialized Only in Global Reset Mode**.

Setting the GMDC[1:0] bits in the RSCFDn(CFD)GCTR register to 01b sets the CHMDC[1:0] bits in each of the RSCFDn(CFD)CmCTR registers (m = 0, 1) to 01b (channel reset mode). If all channels are forced to transition to channel reset mode, the CAN module transitions to global reset mode. Channels that are already in channel reset mode or channel stop mode do not transition (because the CHMDC[1:0] bits have already been set to 01b).

28.6.1.3 Global Test Mode

In global test mode, settings for test-related registers are performed. When the CAN module transitions to global test mode, all CAN communications are disabled.

Setting the GMDC[1:0] bits in the RSCFDn(CFD)GCTR register to 10b sets the CHMDC[1:0] bits in each of the RSCFDn(CFD)CmCTR register to 10b (channel halt mode). If all channels are forced to transition to channel halt mode, the CAN module transitions to global test mode. Channels that are in channel stop mode, channel reset mode, or channel halt mode do not transition.

28.6.1.4 Global Operating Mode

The RS-CANFD module operates in global operating mode.

When the GMDC[1:0] bits in the RSCFDn(CFD)GCTR register are set to 00b, the RS-CANFD module transitions to global operating mode.

28.6.2 Channel Modes

Figure 28.5 shows a channel mode state transition chart. Table 28.35 shows the channel mode transition time.

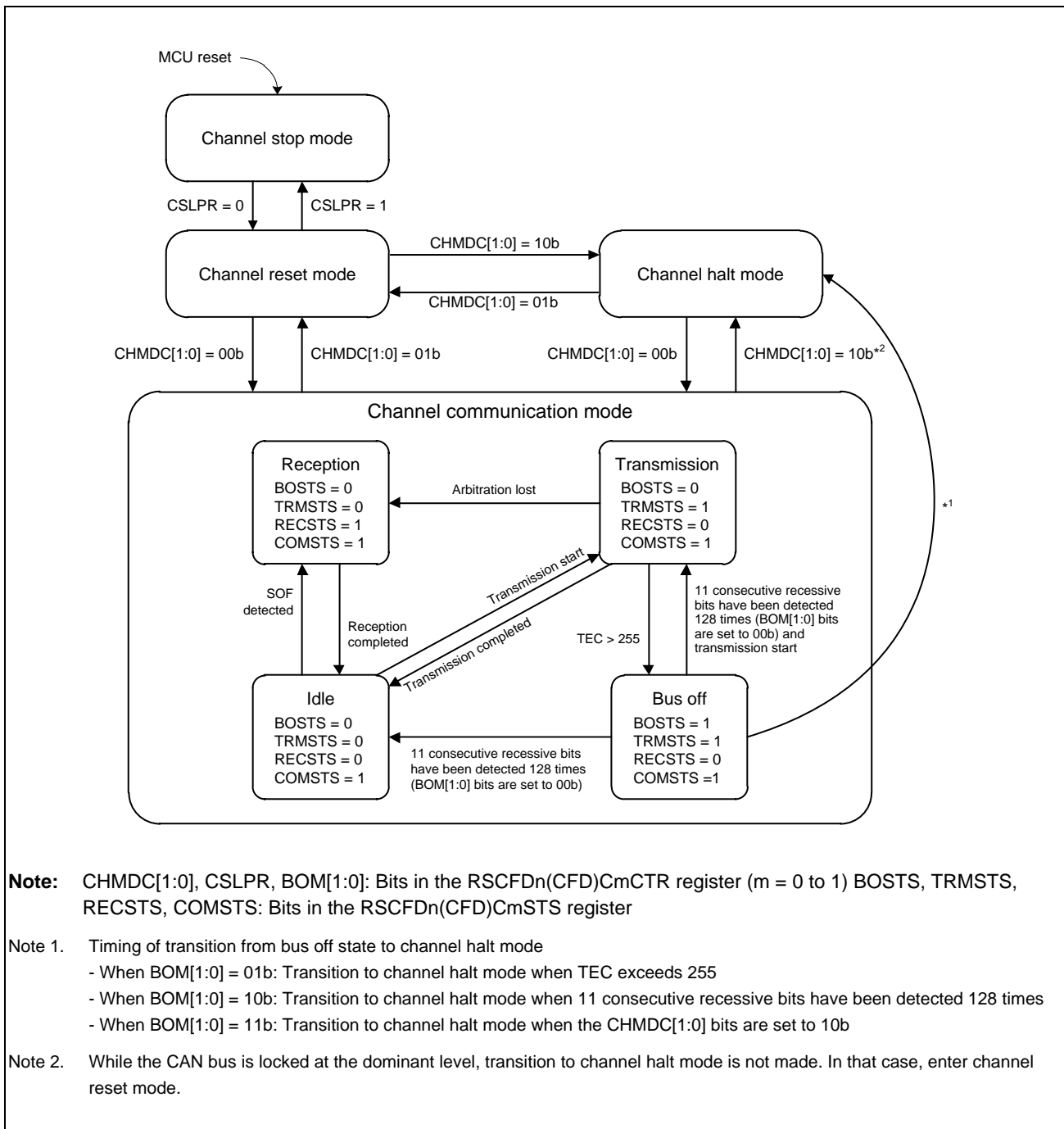

Figure 28.5 Channel Mode State Transition Chart

Table 28.35 Channel Mode Transition Time

Mode before Transition	Mode after Transition	Maximum Transition Time
Channel stop	Channel reset	Three pclk cycles
Channel reset	Channel stop	Three pclk cycles
Channel reset	Channel halt	Three CANm bit times* ¹
Channel reset	Channel communication	Four CANm bit times* ¹
Channel halt	Channel reset	Two CANm bit times* ¹
Channel halt	Channel communication	Four CANm bit times* ¹
Channel communication	Channel reset	Two CANm bit times* ¹
Channel communication	Channel halt	Two CANm frames

Note 1. In CANFD mode, this time value is the CANm bit time of the nominal bit rate.

28.6.2.1 Channel Stop Mode

In channel stop mode, clocks are not supplied to channels and therefore power consumption is reduced. CAN registers can be read, but writing data to them is prohibited. Register values are retained.

Each channel enters channel stop mode after the MCU is reset. Channels also transition to channel stop mode when the GSLPR bit in the RSCFDn(CFD)CmCTR register (m = 0, 1) is set to 1 (channel stop mode) in channel reset mode. The GSLPR bit should not be modified in channel communication mode and channel halt mode.

28.6.2.2 Channel Reset Mode

In channel reset mode, channel settings are performed. When a channel transitions to channel reset mode, some channel-related registers are initialized. For registers to be initialized, see **Table 28.37, Registers Initialized in Global Reset Mode or Channel Reset Mode**.

When the CHMDC[1:0] bits in the RSCFDn(CFD)CmCTR register are set to 01b (channel reset mode) during CAN communication, communication is terminated before it is completed and the channel transitions to channel reset mode. **Table 28.36** shows the operation when the CHMDC[1:0] bits are set to 01b (channel reset mode) during CAN communication.

28.6.2.3 Channel Halt Mode

In channel halt mode, settings for test-related registers of channels are performed. When a channel transitions to channel halt mode, CAN communication of the channel stops.

Table 28.36 shows operation when the CHMDC[1:0] bits are set to 10b (channel halt mode) during CAN communication.

Table 28.36 Operation in Transitions to Channel Reset Mode/Channel Halt Mode

Mode	During Reception	During Transmission	Bus Off State
Channel reset (CHMDC[1:0] = 01b)	Transitions to channel reset mode before reception is completed.* ¹	Transitions to channel reset mode before transmission is completed.* ¹	Transitions to channel reset mode before bus off recovery.
Channel halt* ³ (CHMDC[1:0] = 10b)	Transitions to channel halt mode after reception is completed.* ²	Transitions to channel halt mode after transmission is completed.	[When BOM[1:0] = 00b] Transitions to channel halt mode (CHMDC[1:0] = 10b) only after bus off recovery. [When BOM[1:0] = 01b] Transitions to channel halt mode automatically when the condition for transition to bus off state is met. [When BOM[1:0] = 10b] Transitions to channel halt mode automatically after bus off recovery. [When BOM[1:0] = 11b] Transitions to channel halt mode immediately after the CHMDC[1:0] bits are set to 10b before bus off recovery.

Note 1. To allow transition to channel reset mode after communication is completed, set the CHMDC[1:0] bits to 10b and confirm that communication has been completed and transition to channel halt mode has been made, and then set the CHMDC[1:0] bits to 01b.

Note 2. While the CAN bus is locked at the dominant level, transition to channel halt mode is not made. In that case, enter channel reset mode. The CAN bus status can be confirmed with the BLF flag of the RSCFDn(CFD)CmERFL register that becomes 1 when dominant lock is detected.

Note 3. In classical CAN mode, when the transition from channel reset mode to channel halt mode is to be made, set the RSCANnCmCFG register in channel reset mode and then shift to channel halt mode. In CANFD mode, set the RSCFDnCFDCmNCFG register and the RSCFDnCFDCmDCFG register, and then make a transition.

28.6.2.4 Channel Communication Mode

In channel communication mode, CAN communication is performed. Each channel has the following communication states during CAN communication.

- Idle: Neither reception nor transmission is in progress.
- Reception: Receiving a message sent from another node.
- Transmission: Transmitting a message.
- Bus off: Isolated from CAN communication.

When the CHMDC[1:0] bits in the RSCFDn(CFD)CmCTR register are set to 00b, the channel transitions to channel communication mode. After that, once 11 consecutive recessive bits have been detected, the COMSTS flag in the RSCFDn(CFD)CmSTS register (m = 0, 1) is set to 1 (communication is ready) and transmission and reception are enabled on the CAN network as an active node. At this time, transmission and reception of messages can be started.

28.6.2.5 Bus Off State

A channel transitions to the bus off state according to the transmit/receive error counter increment/decrement rules of the CAN specifications.

The conditions for returning from the bus off state are determined by the BOM[1:0] bits in the RSCFDn(CFD)CmCTR register.

- When BOM[1:0] = 00b:
Bus off recovery is compliant with the CAN specifications. After 11 consecutive recessive bits have been detected 128 times, a channel returns from the bus off state to the CAN communication ready state (error active state). At that time, the TEC[7:0] and REC[7:0] bits in the RSCFDn(CFD)CmSTS register are initialized to H'00, the BORF flag in the RSCFDn(CFD)CmERFL register is set to 1 (bus off recovery is detected), and a bus off recovery interrupt request is generated. When the CHMDC[1:0] bits in the RSCFDn(CFD)CmCTR register are set to 10b (channel halt mode) in the bus off state, the channel transitions to channel halt mode after bus off recovery has been completed (11 consecutive recessive bits have been detected 128 times).
- When BOM[1:0] = 01b:
When a channel transitions to the bus off state, the CHMDC[1:0] bits are set to 10b and the channel transitions to channel halt mode. At that time, the TEC[7:0] and REC[7:0] bits are initialized to H'00. The BORF flag is not set to 1, and bus off recovery interrupt request is not generated.
- When BOM[1:0] = 10b:
When a channel has transitioned to the bus off state, the CHMDC[1:0] bits are set to 10b. After bus off recovery has been completed (11 consecutive recessive bits have been detected 128 times), the channel transitions to channel halt mode. At that time, the TEC[7:0] and REC[7:0] bits are initialized to H'00, the BORF flag is set to 1, and a bus off recovery interrupt request is generated.
- When BOM[1:0] = 11b:
When the CHMDC[1:0] bits are set to 10b in the bus off state, the channel transitions to channel halt mode before bus off recovery is completed. At that time, the TEC[7:0] and REC[7:0] bits are initialized to H'00, but the BORF flag is not set to 1. Also, a bus off recovery interrupt is not generated.
However, the BORF flag becomes 1 and a bus off recovery interrupt request is generated if a CAN module transitions to error active state (by detecting 128 times of 11 consecutive recessive bits) before CHMDC[1:0] bits are set to 10b.

If the RS-CANFD module causes the channel to transition to channel halt mode simultaneously with a program write to the CHMDC[1:0] bits, the program write takes precedence. An automatic transition to channel halt mode when the BOM[1:0] bits are set to 01b or 10b is made only when the CHMDC[1:0] bits are 00b (channel communication mode). Furthermore, setting the RTBO bit in the RSCFDn(CFD)CmCTR register to 1 allows a forced return from the bus off state. As soon as the RTBO bit is set to 1, the state changes to the error active state. After 11 consecutive recessive bits have been detected, the CAN module becomes ready for communication. In this case, the BORF flag is not set to 1 and the TEC[7:0] and REC[7:0] bits are initialized to H'00. Write 1 to the RTBO bit only when the BOM[1:0] value is 00b. Writing the RTBO bit to 1 in a state other than the bus off state is ignored, and the RTBO bit is immediately set to 0.

28.6.3 Initializing Registers by Transition to CAN Mode

Table 28.37 lists bits and flags to be initialized by a transition to channel reset mode. These bits and flags are also initialized by a transition to global reset mode. Furthermore, **Table 28.38** lists bits and flags to be initialized only by a transition to global reset mode.

Table 28.37 Registers Initialized in Global Reset Mode or Channel Reset Mode

Register	Bit/Flag
RSCFDn(CFD)CmCTR register	(ROM), CRCT, CTMS[1:0], CTME, CHMDC[1:0]
RSCFDn(CFD)CmSTS register	CHLTSTS, EPSTS, BOSTS, TRMSTS, RECSTS, COMSTS, (ESIF), REC[7:0], TEC[7:0]
RSCFDn(CFD)CmERFL register	CRCREG[14:0], ADERR, B0ERR, B1ERR, CERR, AERR, FERR, SERR, ALF, BLF, OVLF, BORF, BOEF, EPF, EWF, BEF
RSCFDnCFDCmFDCTR register	EOCCLR, SOCCLR
RSCFDnCFDCmFDSTS register	SOC[7:0], EOC[7:0], SOCO, EOCO, TDCVF, TDCR[6:0]
RSCFDnCFDCmFDCRC register	CRCREG[20:0], SCNT[3:0]
RSCFDn(CFD)CFCCk register	When transmit/receive FIFO buffer is in transmit mode or gateway mode: CFE
RSCFDn(CFD)CFSTSk register	When transmit/receive FIFO buffer is in transmit mode or gateway mode: CFMC[7:0], CFFLL, CFEMP, CFMLT, CFRXIF, CFTXIF
RSCFDn(CFD)CFTISTS register	CFkTXIF
RSCFDn(CFD)TMCP register	TMOM, TMTAR, TMTR
RSCFDn(CFD)TMSTSp register	TMTARM, TMTRM, TMTRF[1:0], TMTSTS
RSCFDn(CFD)TMTRSTSy register	TMTRSTSp (Bits of corresponding channel are initialized in channel reset mode.)
RSCFDn(CFD)TMTARSTSy register	TMTARSTSp (Bits of corresponding channel are initialized in channel reset mode.)
RSCFDn(CFD)TMTCASTSy register	TMTCASTSp (Bits of corresponding channel are initialized in channel reset mode.)
RSCFDn(CFD)TMTASTSy register	TMTASTSp (Bits of corresponding channel are initialized in channel reset mode.)
RSCFDn(CFD)TXQCCm register	TXQE
RSCFDn(CFD)TXQSTSm register	TXQIF, TXQFLL, TXQEMP
RSCFDn(CFD)THLCCm register	THLE
RSCFDn(CFD)THLSTSm register	THLMC[4:0], THLIF, THLELT, THLFLL, THLEMP
RSCFDn(CFD)GTINTSTS0 register	TSIFm, TAIFm, TQIFm, CFTIFm, THIFm (m =0, 1)

Note: Bits and flags in parentheses exist only in registers for use in CANFD mode.

Table 28.38 Registers Initialized Only in Global Reset Mode

Register	Bit/Flag
RSCFDn(CFD)GSTS register	GHLTSTS
RSCFDn(CFD)GERFL register	EEF0, EEF1, (CMPOF), THLES, MES, DEF
RSCFDn(CFD)GTSC register	TS[15:0]
RSCFDn(CFD)RMNDy register	RMNSq
RSCFDn(CFD)RFCCx register	RFE
RSCFDn(CFD)RFSTSx register	RFMC[7:0], RFIF, RFMLT, RFFLL, RFEMP
RSCFDn(CFD)CFCCk register	When transmit/receive FIFO buffer is in receive mode: CFE
RSCFDn(CFD)CFSTSk register	When transmit/receive FIFO buffer is in receive mode: CFMC[7:0], CFFLL, CFEMP, CFTXIF, CFRXIF, CFMLT
RSCFDn(CFD)FESTS register	CFkEMP, RFxEMP
RSCFDn(CFD)FFSTS register	CFkFLL, RFxFLL
RSCFDn(CFD)FMSTS register	CFkMLT, RFxMLT
RSCFDn(CFD)RFISTS register	RFxIF
RSCFDn(CFD)CFRISTS register	CFkRXIF
RSCFDnCFDCTCT register	CFDMAEm, RFDMAEx
RSCFDnCFDCTSTS register	CFDMASTSm, RFDMASTsX
RSCFDn(CFD)GTSTCFG register	RTMPS[6:0], C0ICBCE, C1ICBCE
RSCFDn(CFD)GTSTCTR register	RTME, ICBCTME

Note: Bits and flags in parentheses exist only in registers for use in CANFD mode.

28.7 Reception Function

There are two reception types.

- Reception by receive buffers:
Zero to 32 receive buffers can be shared by all channels. Since messages stored in receive buffers are overwritten at each reception, the latest receive data can always be read.
- Reception by receive FIFO buffers and transmit/receive FIFO buffers (receive mode):
Eight receive FIFO buffers can be shared by all channels and three dedicated transmit/receive FIFO buffers are provided for each channel. Messages of up to the number of buffer stages specified with the RFDC[2:0] and CFDC[2:0] bits can be stored in FIFO buffers and can be read sequentially from the oldest.

28.7.1 Data Processing Using the Receive Rule Table

Data processing using the receive rule table allows dispatching of selected messages to the specified buffer. Data processing includes acceptance filter processing, DLC filter processing, routing processing, label addition processing, and mirror function processing.

Up to 128 receive rules can be registered per channel and up to (64 × number of channels) total receive rules can be registered in the entire module. (Up to 128 receive rules can be registered in this module that has two channels.) Set receive rules for each channel. Receive rules cannot be shared with other channels. If receive rules are not set, no messages can be received. **Figure 28.6** illustrates how receive rules are registered.

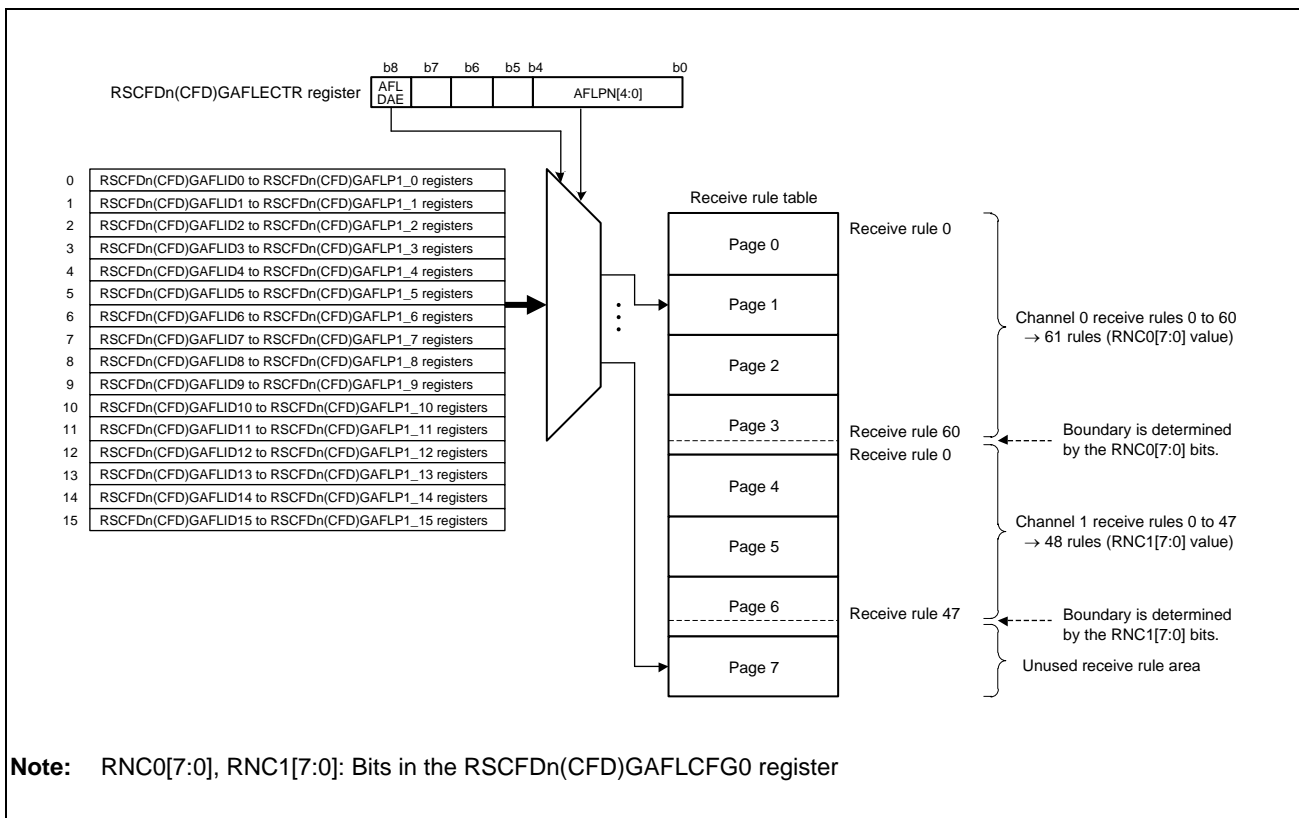

Figure 28.6 Entry of Receive Rules (for Setting Channels 0 and 1)

NOTE

Receive rules for each channel must be set in contiguous blocks.

Channel 1 rules and channel 0 rules must be set separately.

Each receive rule consists of 16 bytes in the RSCFDn(CFD)GAFLIDj, RSCFDn(CFD)GAFLMj, RSCFDn(CFD)GAFLP0_j, and RSCFDn(CFD)GAFLP1_j registers (j = 0 to 15). The RSCFDn(CFD)GAFLIDj register is used to set GAFLID, GAFLIDE bit, GAFLRTR bit, and the mirror function, the RSCFDn(CFD)GAFLMj register is used to set mask, the RSCFDn(CFD)GAFLP0_j register is used to set label information to be added, DLC value, and storage receive buffer, and the RSCFDn(CFD)GAFLP1_j register is used to set storage FIFO buffer. Up to 16 receive rules can be set per page.

28.7.1.1 Acceptance Filter Processing

In the acceptance filter processing, the ID data, IDE bit, and RTR bit in a received message are compared with the ID data, IDE bit, and RTR bit set in the receive rule of the corresponding channel. When all these bits match, the message passes through the acceptance filter processing. The ID data, IDE bit, and RTR bit in the received message which correspond to the bits set to 0 (bits are not compared) in the RSCFDn(CFD)GAFLMj register are not compared and are regarded as matched.

Check begins with the receive rule of the minimum number for the corresponding channel. When all the bits to be compared in a received message match the bits set in the receive rule or when all the receive rules are compared without any match, filter processing stops. If there is no matching receive rule, the received message is not stored in the receive buffer or FIFO buffer.

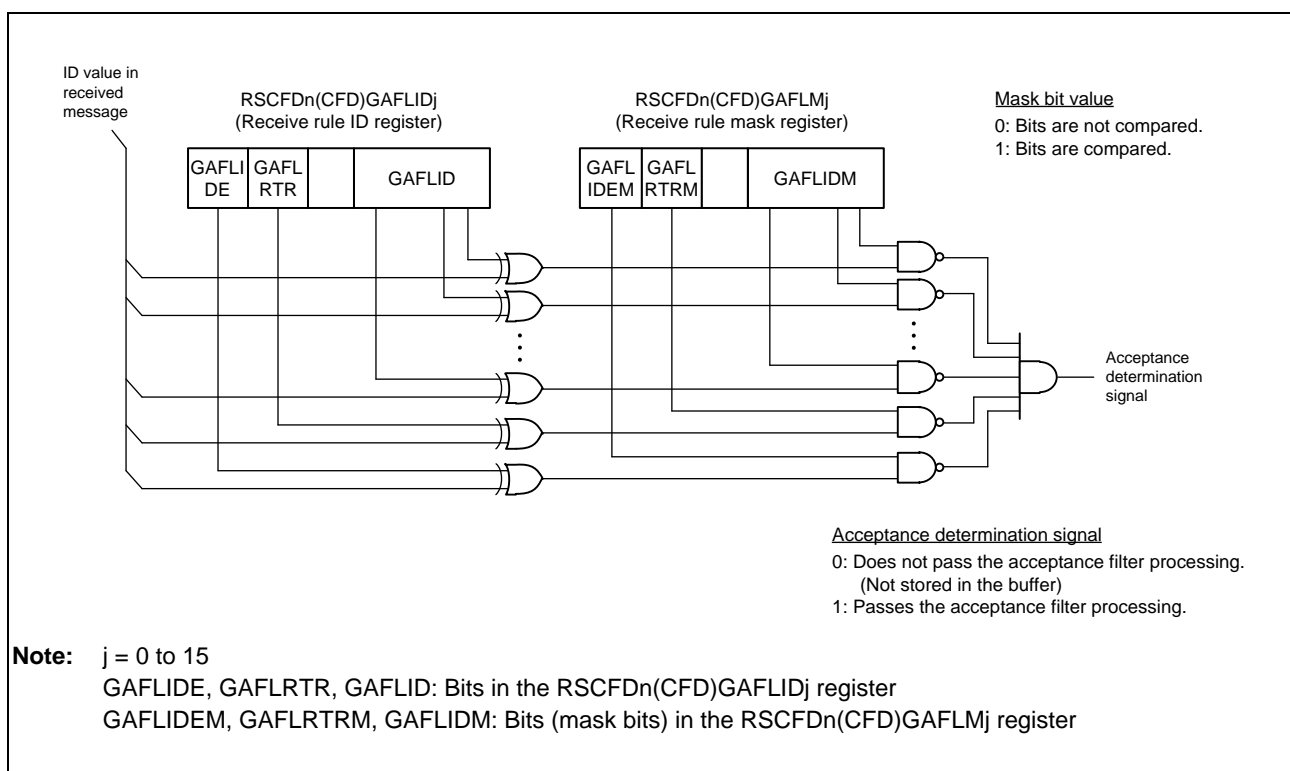

Figure 28.7 Acceptance Filter Function

28.7.1.2 DLC Filter Processing

When the DCE bit in the RSCFDn(CFD)GCFG register is set to 1 (DLC check is enabled), DLC filter processing is added to messages that passed through the acceptance filter processing. When the DLC value in a message is equal to or larger than the DLC value set in the receive rule, the message passes through the DLC filter processing.

When a message has passed through the DLC filter processing with the DRE bit in the RSCFDn(CFD)GCFG register set to 0 (DLC replacement is disabled), the DLC value in the received message is stored in the buffer. In this case, all the data bytes in the received message are stored in the buffer.

When a message has passed through the DLC filter processing with the DRE bit in the RSCFDn(CFD)GCFG register set to 1 (DLC replacement is enabled), the DLC value in the receive rule is stored in the buffer instead of the DLC value in the received message. In this case, a value of H'00 is stored in each data byte beyond the number of bytes which is indicated by the DLC value in the receive rule.

When the DLC value in the received message is smaller than that in the receive rule, the message does not pass through the DLC filter processing. In this case, the message is not stored in the receive buffer or the FIFO buffer and the DEF flag in the RSCFDn(CFD)GERFL register is set to 1 (a DLC error is present).

28.7.1.3 Routing Processing

Messages that passed through the acceptance filter processing and the DLC filter processing are stored in receive buffers, receive FIFO buffers, or transmit/receive FIFO buffers (set to receive mode or gateway mode). Message storage destination is set by the GAFLRMV and GAFLRMDP[6:0] bits in the RSCFDn(CFD)GAFLP0_j register (j = 0 to 15) and by the RSCFDn(CFD)GAFLP1_j register. Messages that passed through the acceptance filter processing and the DLC filter processing can be stored in up to eight buffers.

In CANFD mode, if the payload length of the received message exceeds the payload storage size of the storage buffer, the CMPOF flag in the RSCFDnCFDGERFL register is set to 1 (payload overflow) and the processing is handled according to the CMPOC bit in the RSCFDnCFDGCFG register. When the CMPOC bit is 0, the received message which exceeds the payload storage size is not stored in the buffer. When the CMPOC bit is 1, the received message is stored in the buffer with payloads exceeding the storage size being discarded.

28.7.1.4 Label Addition Processing

It is possible to add 12-bit label information to messages that passed through the filter processing and store them in buffers. This label information is set in the GAFLPTR[11:0] bits in the RSCFDn(CFD)GAFLP0_j register.

28.7.1.5 Mirror Function Processing

The mirror function allows the CAN node to receive its own transmitted messages. The mirror function is made available by setting the MME bit in the RSCFDn(CFD)GCFG register to 1 (mirror function is enabled).

When the mirror function is in use, receive rules for which the GAFLLB bit in the RSCFDn(CFD)GAFLIDj register is set to 0 are used for data processing when receiving messages transmitted from other CAN nodes. When the CAN node is receiving its own transmitted messages, receive rules for which the GAFLLB bit is set to 1 are used for data processing.

28.7.1.6 Timestamp

The timestamp counter is a 16-bit free-running counter used for recording message receive time and transmission time. The timestamp counter value is fetched at the timing set with the TSCCFG[1:0] bits in the RSCFDn(CFD)GCFG register and is then stored in a receive buffer or a FIFO buffer together with the message ID and data during data reception. The clock source of the timestamp counter is selected by the TSBTCS[2:0] and TSSS bits in the RSCFDn(CFD)GCFG register. In classical CAN mode, either pclk/2 or the CANm bit time clock (m = 0, 1). In CANFD mode, the clock source is selectable from pclk/2 or nominal CANm bit time clock. However, do not select the nominal CANm bit time clock of channels that handle CANFD frames. The timestamp counter count source is obtained by dividing the selected clock source by the TSP[3:0] value in the RSCFDn(CFD)GCFG register.

When the CANm bit time clock or nominal CANm bit time clock is used as a clock source, the timestamp counter stops when the corresponding channel transitions to channel reset mode or channel halt mode. When the pclk/2 is used as a clock source, the timestamp function is not affected by channel mode.

The timestamp counter value is reset to H'0000 by setting the TSRST bit in the RSCFDn(CFD)GCTR register to 1.

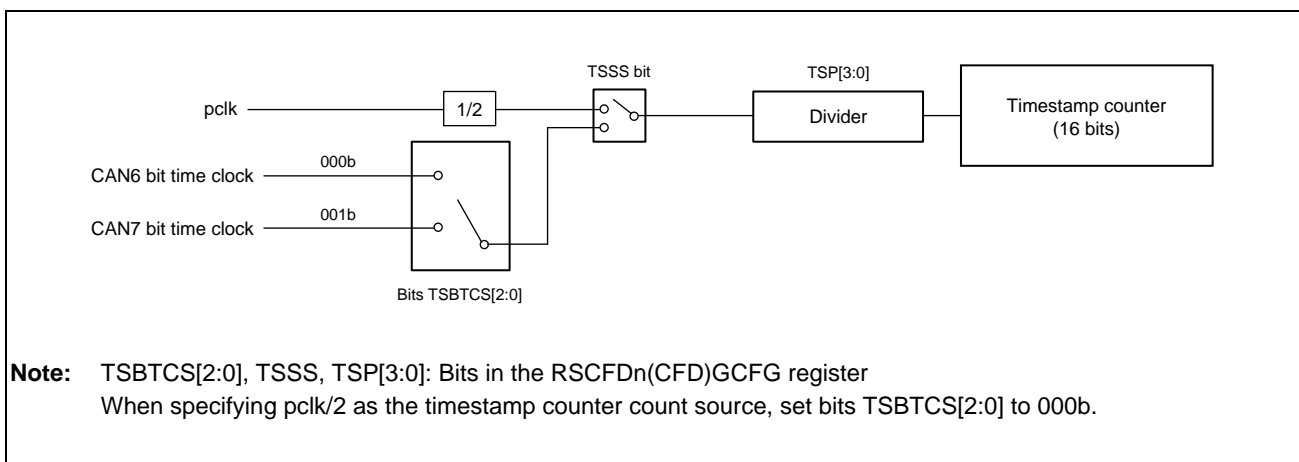

Figure 28.8 Timestamp Function Block Diagram

28.8 Transmission Functions

There are three types of transmission. In classical CAN mode, transmittable payload length is 8 bytes in every transmission type. In CANFD mode, transmittable payload length varies with transmission types.

- Transmission using transmit buffers:

Each channel has 16 buffers. Transmittable payload length in CANFD mode is 20 bytes. However, when transmit buffer merge mode is used, four buffers out of 16 buffers are allocated as a payload-only storage area and two buffers are able to transmit payloads with a length of more than 20 bytes.
- Transmission using transmit/receive FIFO buffers (transmit mode):

Each channel has three FIFO buffers. Up to 128 messages can be contained in a single FIFO buffer. Transmittable payload length in CANFD mode is 64 bytes. Each FIFO buffer is used with a link to a transmit buffer. Only the message to be transmitted next in a FIFO buffer becomes the target of transmit priority determination. Messages are transmitted sequentially on a first-in, first-out basis.
- Transmission using transmit queues:

Up to 16 transmit buffers per channel can be allocated to the transmit queues. Transmittable payload length in CANFD mode is 20 bytes. Transmit buffer ((16 × m) + 15) is used as an access window of a corresponding channel. Transmit buffers are allocated to transmit queues in descending order of buffer number. All messages in transmit queues, which are targets of priority determination, are transmitted in the order of ID number.

Figure 28.9 shows the allocation of transmit queues and transmit/receive FIFO buffer link.

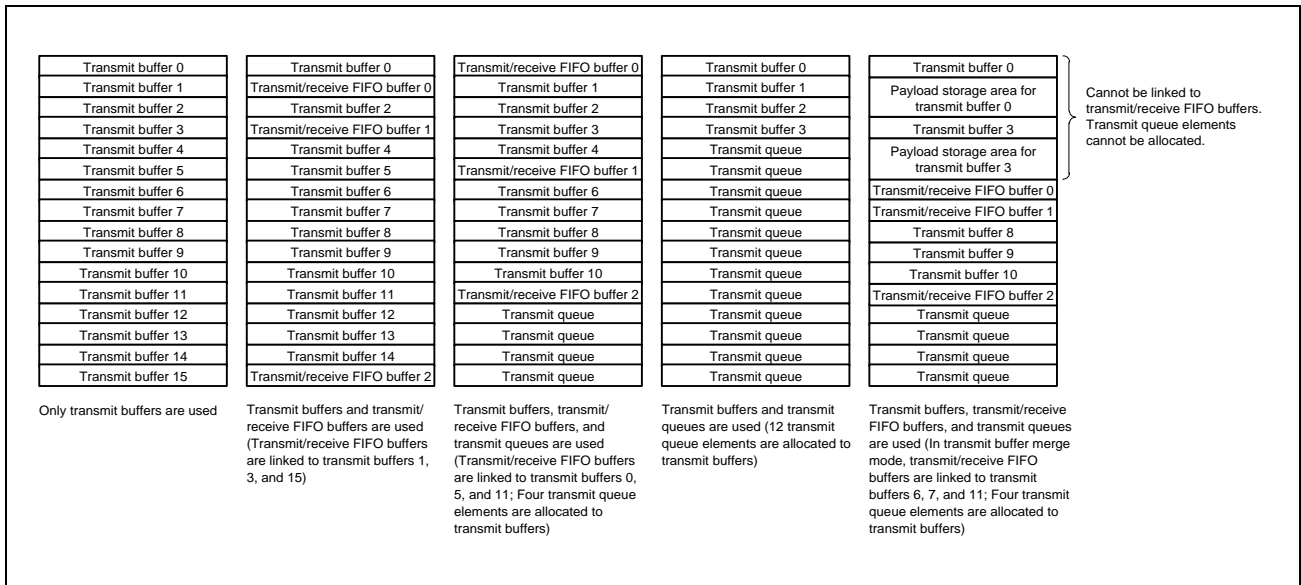

Figure 28.9 Allocation of Transmit Queues and Transmit/Receive FIFO Buffer Links

28.8.1 Transmit Priority Determination

If transmit requests are issued from multiple buffers or from the queue on the same channel, transmit priority is determined using one of the following methods.

The priority is determined by using one of the following methods.

- ID priority (TPRI bit = 0)
- Transmit buffer number priority (TPRI bit = 1)

All CAN channels use the setting of the TPRI bit in the RSCFDn(CFD)GCFG register.

When the TPRI bit is set to 0, messages are transmitted according to the priority of stored message IDs. ID priority conforms to the CAN bus arbitration specification defined in the CAN specifications. All IDs of pending transmit messages are targets of priority determination, regardless of whether they are stored in transmit buffers, transmit/receive FIFO buffers (set to transmit mode or gateway mode), or the transmit queue. If even a single transmit queue is used, select ID priority. When transmit/receive FIFO buffers are used, the oldest message in a FIFO buffer becomes the target of priority determination. When a message is being transmitted from a transmit/receive FIFO buffer, the next message in the FIFO buffer becomes the target of priority determination. When a transmit queue is used, all messages in the transmit queue are targets of priority determination. If the same ID is set for two or more buffers, the buffer with the smaller buffer number takes precedence.

When the TPRI bit is set to 1, the message in the transmit buffer with the minimum buffer number among all buffers with a transmit request is transmitted first. When transmit/receive FIFO buffers are linked to transmit buffers, transmit priority is determined according to linked transmit buffer numbers.

When messages are retransmitted due to an arbitration-lost or an error, transmit priority determination is made again regardless of the TPRI bit.

28.8.2 Transmission Using Transmit Buffers

Setting the transmit request bit (TMTR bit in the RSCFDn(CFD)TMCp register) in a transmit buffer to 1 (transmission is requested) allows transmission of data frames or remote frames.

The transmit result is shown by the TMTRF[1:0] flag in the corresponding RSCFDn(CFD)TMSTSp register (p = 0 to 31). When transmit completes successfully, the TMTRF[1:0] flag is set to 10b (transmission has been completed (without transmit abort request)) or 11b (transmission has been completed (with transmit abort request)).

28.8.2.1 Transmit Abort Function

With respect to transmit buffers for which the TMTRM bit in the RSCFDn(CFD)TMSTSp register is set to 1 (a transmit request is present), when the TMTAR bit in the RSCFDn(CFD)TMCp register is set to 1 (transmit abort is requested), the transmit request is canceled. When transmit abort is completed, the TMTRF[1:0] flag in the RSCFDn(CFD)TMSTSp register is set to 01b (transmit abort has been completed) and the transmit request is canceled (clearing the TMTRM bit to 0).

A message that is being transmitted or a message to be transmitted next according to the transmit priority determination cannot be aborted. However, when an arbitration-lost or an error occurs during transmission of a message for which the TMTAR bit is set to 1, retransmission is not performed.

28.8.2.2 One-Shot Transmission Function (Retransmission Disabling Function)

When the TMOM bit in the RSCFDn(CFD)TMCp register is set to 1 (one-shot transmission is enabled), transmission is performed only once. Even if an arbitration-lost or an error occurs, retransmission is not performed.

The one-shot transmit result is shown by the TMTRF[1:0] flag in the corresponding RSCFDn(CFD)TMSTSp register. When one-shot transmission completes successfully, the TMTRF[1:0] flag is set to 10b or 11b. When an arbitration-lost or an error occurs, the TMTRF[1:0] flag is set to 01b (transmit abort has been completed).

28.8.2.3 Transmit Buffer Merge Mode (Only in CANFD Mode)

Transmit buffers can transmit messages with a payload length of 20 bytes, but can transmit messages with a payload length of up to 64 bytes by merging three transmit buffers in transmit buffer merge mode.

Setting the TMME bit to 1 in the RSCFDnCFDCmFDCFG register enables transmit buffer merge mode. In this mode, six buffers per channel become a merge area and two sets of transmit buffers $(16 \times m) + 0$ to $(16 \times m) + 2$ and transmit buffers $(16 \times m) + 3$ to $(16 \times m) + 5$ are merged. A transmission request is made by the first transmit buffer, and subsequent two buffers are used as a payload storage area. Do not set the transmission request bit (TMTR bit in the RSCFDnCFDTMCp register) and the transmission abort request bit (TMTAR bit in the RSCFDnCFDTMCp register) to 1 for transmit buffers except for the first buffer.

While transmit buffer merge mode is enabled, do not link the transmit/receive FIFO buffer to the merged buffers or allocate it to the transmit queue.

28.8.3 Transmission Using FIFO Buffers

Multiple messages can be stored in a single transmit/receive FIFO buffers, up to the number specified by the FIFO buffer depth, which is set by the CFDC[2:0] bits in the RSCFDn(CFD)CFCCk register (k = 0 to 5). Messages are transmitted sequentially on a first-in, first-out basis.

Each transmit/receive FIFO buffer is linked to a transmit buffer selected by the CFTML[3:0] bits in the RSCFDn(CFD)CFCCk register. When the CFE bit in the RSCFDn(CFD)CFCCk register is set to 1 (transmit/receive FIFO buffers are used), transmit/receive FIFO buffers become targets of transmit priority determination. Priority of only the next transmit message is determined in the FIFO buffer.

When the CFE bit is set to 0 (no transmit/receive FIFO buffer is used), the CFEMP flag is set to 1 (the transmit/receive FIFO buffer contains no message (buffer empty)) at the timing below.

- The transmit/receive FIFO buffer becomes empty immediately if the message in it is not being transmitted or is not to be transmitted next.
- The transmit/receive FIFO buffer becomes empty after transmission completion, CAN bus error detection, arbitration-lost or the transition to channel halt mode in the case that a message in it is being transmitted or to be transmitted next.

When the CFE bit is cleared to 0, all messages in transmit/receive FIFO buffers are lost and messages cannot be stored in FIFO buffers. Confirm that the CFEMP flag is set to 1 before setting the CFE bit to 1 again.

28.8.3.1 Interval Transmission Function

A message transmission interval time can be set to space the transmission of messages from the same FIFO buffer when using a transmit/receive FIFO buffer set to transmit mode or gateway mode.

Immediately after the first message has been transmitted successfully from the FIFO buffer with the CFE bit in the RSCFDn(CFD)CFCCk register set to 1, the interval timer starts counting (after EOF7 of the CAN protocol). After that, when the interval time has passed, the next message is transmitted. The interval timer stops in channel reset mode or by clearing the CFE bit to 0.

The interval time is set by the CFITT[7:0] bits in the RSCFDn(CFD)CFCCk register. When the interval timer is not used, set the CFITT[7:0] bits to H'00.

Select an interval timer count source using the CFITR and CFITSS bits in the RSCFDn(CFD)CFCCk register. When the CFITR and CFITSS bits are set to 00b, the count source is obtained by dividing pclk/2 by the value of the ITRCP[15:0] bits. When the CFITR and CFITSS bits are set to 10b, the count source is obtained by dividing pclk/2 by (the value of the ITRCP[15:0] bits in the RSCFDn(CFD)GCFG register × 10). When the CFITR and CFITSS bits are set to x1b, the CANm bit time clock becomes a count source in classical CAN mode and the nominal CANm bit time clock becomes a count source in CANFD mode. Use this count source only for the channel that does not handle the CANFD frames. The interval time is calculated by the following equations where M is the value of ITRCP[15:0] and N is the value of CFITT[7:0].

- When CFITR and CFITSS = 00b:

$$\frac{1}{\text{pclk frequency}} \times 2 \times M \times N$$

- When CFITR and CFITSS = 10b:

$$\frac{1}{\text{pclk frequency}} \times 2 \times M \times 10 \times N$$

- When CFITR and CFITSS = x1b:

Classical CAN mode: $\frac{1}{\text{CANm bit time clock frequency}} \times N$

CANFD mode: $\frac{1}{\text{Nominal CANm bit time clock frequency}} \times N$

Figure 28.10 shows the interval timer block diagram.

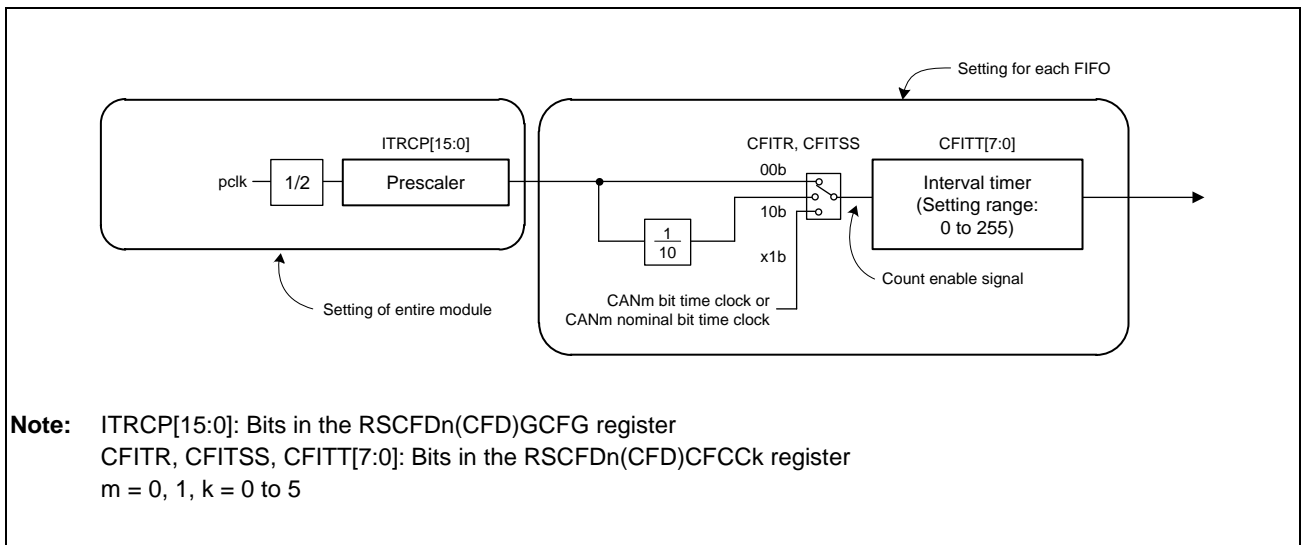

Figure 28.10 Interval Timer Block Diagram

Figure 28.11 shows the interval timer timing diagram.

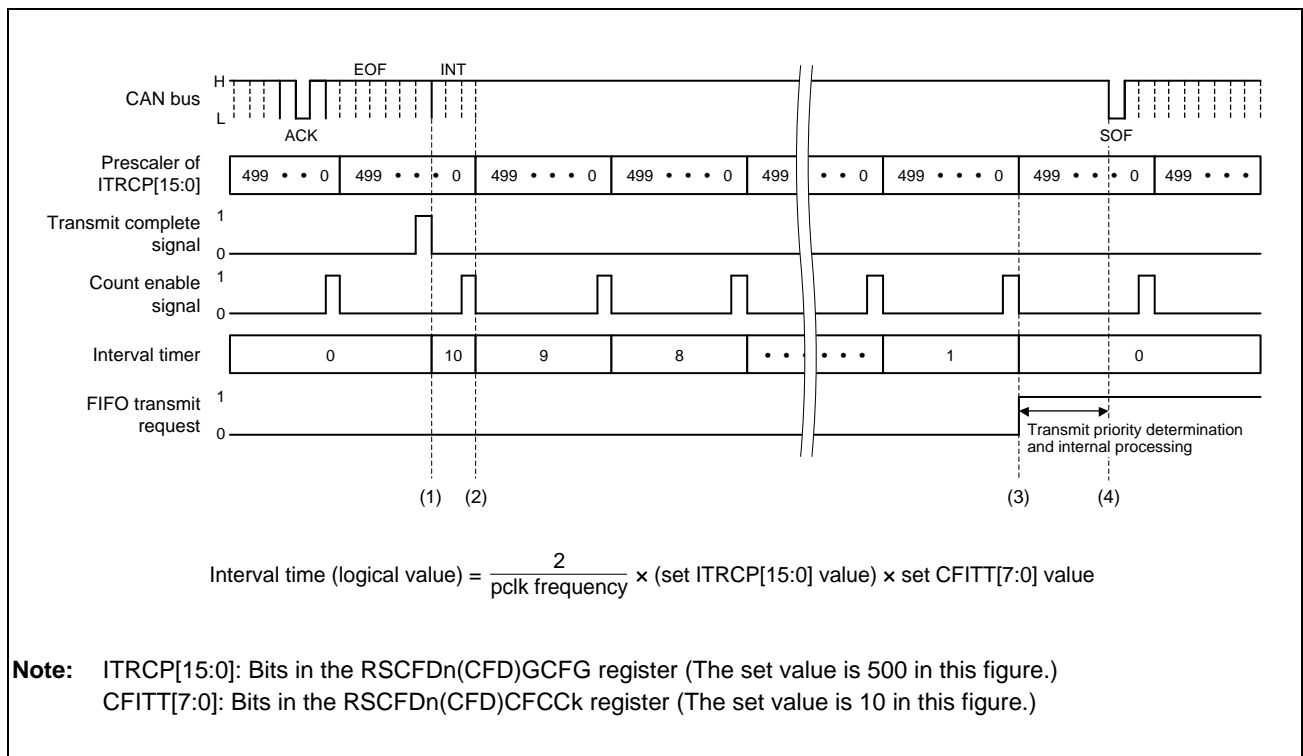

Figure 28.11 Interval Timer Timing Chart

- (1) The interval timer starts counting upon completion of transmission. Since the prescaler is not initialized at the time of transmission completion, the first interval time contains an error of up to one count of the interval timer.
- (2) The interval timer is decremented by the next count enable signal.
- (3) When the interval timer has decreased to 0, the transmit/receive FIFO buffer issues a transmit request.
- (4) The transmit/receive FIFO buffer is determined for the next transmission by the priority determination, it starts transmitting data. Transmission starts usually with a delay of three CANm bit time clock cycles or less from the issue of transmit request. If multiple internal processes (such as receive filter processing, message routing, and transmit priority determination) take place in all channels, a delay of up to 644 cycles of the pclk may be generated.

28.8.4 Transmission Using Transmit Queues

Three to sixteen buffers (up to 10 buffers in transmit buffer merge mode) are allocated to a transmit queue for each channel, and transmit buffer $((16 \times m) + 15)$ is used as an access window of a corresponding channel.

All messages in a transmit queue are targets of transmit priority determination and are transmitted in the ID priority order regardless of storage sequence. If two messages having the same ID are stored in a transmit queue, these messages are not always transmitted in the order of their storage in the transmit queue.

Setting the TXQE bit in the RSCFDn(CFD)TXQCCm register to 0 disables transmit queues. When the TXQE bit is set to 0, the TXQEMP flag in the RSCFDn(CFD)TXQSTSm register is set to 1 (the transmit queue contains no messages (transmit queue empty)) at the timing below.

- The transmit queue becomes empty immediately when no message in it is being transmitted or will be transmitted next.
- The transmit queue becomes empty after transmission completion, CAN bus error detection, arbitration-lost, or the transition to channel halt mode when a message in it is being transmitted or will be transmitted next.

When the TXQE bit is cleared to 0, all messages in transmit queues are lost and messages cannot be stored in transmit queues. Confirm that the TXQEMP flag is set to 1 before setting the TXQE bit to 1 again.

28.8.5 Transmit Data Padding (Only in CANFD Mode)

When the payload length indicated by the set DLC value in a transmit message exceeds the payload storage area size of a buffer to be used for transmission, excessive payloads are padded by H'CC.

This processing is performed in the following cases when the transmit buffer merge mode is disabled (TMME bit in the RSCFDnCFDCmFD CFG register is 0).

- Transmit/receive FIFO set to transmission or gateway mode:
When the payload length of the transmit DLC exceeds the transmit/receive FIFO payload storage area size set by the CFPLS[2:0] bits in the RSCFDnCFDCFCCK register
- Transmit buffer (including transmit queue):
When the payload length of the transmit DLC exceeds 20 bytes

When the transmit buffer merge mode is enabled, no transmit data is padded in any transmission using a transmit buffer, transmit/receive FIFO buffer, or transmit queue. At this time, do not set a payload length more than the payload storage size of the buffer for transmitting as the DLC value in the transmit message.

28.8.6 Transmit History Function

Information about transmission-completed messages can be stored in the transmit history buffer. Each channel has a single transmit history buffer that can contain 16 sets of transmit history data.

A message transmit source buffer type can be selected by the THLDTE bit in the RSCFDn(CFD)THLCCm register. The THLEN bit in the RSCFDn(CFD)CFIDk register (k = 0 to 5) determines whether transmit history data is stored for each message.

In classical CAN mode, the TMTSCE bit in the RSCANnGCFG register can be used to set whether to include a timestamp value in the transmit history data. In CANFD mode, a timestamp value is always included.

The following information on a transmitted message will be stored in the transmit history buffer after the successful completion of transmission.

Storage of the transmit history data after the successful completion of transmission may take up to 128 cycles of pclk in classical CAN mode or 396 cycles of pclk in CANFD mode.

- Buffer type: 001b: Transmit buffer
010b: Transmit/receive FIFO buffer
100b: Transmit queue
- Buffer number: Number of source transmit buffer, transmit queue, or transmit/receive FIFO buffer.
This number depends on buffer types. See **Table 28.39**.
- Label data: Label information of the transmit message
- Timestamp: Timestamp value of the transmit message
(When the TMTSCE bit is 1 in classical CAN mode)

Table 28.39 Transmit History Data Buffer Numbers

Buffer Type	001b	010b	100b
Buffer No.			
0000b	Transmit buffer 16 × m + 0	Buffer numbers of the transmit buffer linked to the transmit/receive FIFO buffer by the CFTML[3:0] bits in the RSCFDn(CFD)CFIDk register (k = 0 to 5)	Buffer numbers of the transmit buffer allocated to the transmit queue that performed transmission
0001b	Transmit buffer 16 × m + 1		
0010b	Transmit buffer 16 × m + 2		
0011b	Transmit buffer 16 × m + 3		
0100b	Transmit buffer 16 × m + 4		
0101b	Transmit buffer 16 × m + 5		
0110b	Transmit buffer 16 × m + 6		
0111b	Transmit buffer 16 × m + 7		
1000b	Transmit buffer 16 × m + 8		
1001b	Transmit buffer 16 × m + 9		
1010b	Transmit buffer 16 × m + 10		
1011b	Transmit buffer 16 × m + 11		
1100b	Transmit buffer 16 × m + 12		
1101b	Transmit buffer 16 × m + 13		
1110b	Transmit buffer 16 × m + 14		
1111b	Transmit buffer 16 × m + 15		

Label data is used to identify each message. Unique label data can be added to each message transmitted from a transmit buffer, transmit queue, or transmit/receive FIFO buffer.

The timestamp value is fetched from the timestamp counter at the SOF (start of frame) timing of the message. For details about the timestamp counter, see **Section 28.7.1.6, Timestamp**.

Transmit history data can be read from the RSCFDn(CFD)THLACCm register. If an attempt is made to store new transmit history data while the buffer is full, the buffer overflows and the new data is discarded.

28.9 Gateway Function

When a transmit/receive FIFO buffer is set to gateway mode, receive messages can be transmitted from an arbitrary channel without CPU intervention.

When the CFM[1:0] bits in the RSCFDn(CFD)CFCCk register are set to 10b (gateway mode) for the transmit/receive FIFO buffer selected by the RSCFDn(CFD)GAFLP1_j register of a channel being used for transmission, messages that pass through filter processing according to the receive rule are stored in the specified transmit/receive FIFO buffer and are automatically transmitted from the buffer.

Messages stored in a transmit/receive FIFO buffer are transmitted sequentially on a first-in, first-out basis. Only the message to be transmitted next becomes the target of transmit priority determination.

Transmit/receive FIFO buffers in the gateway mode are disabled by setting the CFE bit in the RSCFDn(CFD)CFCCk register to 0 and the CFEMP flag becomes 1 according to the timing below.

- The transmit/receive FIFO buffer becomes empty immediately when the message in it is not being transmitted and will not to be transmitted next.
- The transmit/receive FIFO buffer becomes empty after transmission completion, CAN bus error detection, or arbitration-lost when the message in it is being transmitted or will be transmitted next.

When the CFE bit is cleared to 0, all messages in transmit/receive FIFO buffers are lost and messages can no longer be stored in transmit/receive FIFO buffers. Confirm that the CFEMP flag is set to 1 before setting the CFE bit to 1 again.

28.9.1 CAN-CANFD Gateway (Only in CANFD Mode)

When the gateway function is used in CANFD mode, a frame to be transmitted can be replaced with a classical CAN frame or a CANFD frame.

Setting the GWEN bit in the RSCFDnCFDCmFDCFG register to 1 enables the CAN-CANFD gateway. The FDF and BRS bits in the transmit frame can be selected by the GWFDF and GWBRS bits in the RSCFDnCFDCmFDCFG register. When the DLC value of the received CAN frame is 1001b or more and the GWFDF bit is 1 (CANFD frame), the DLC value is replaced with 1000b.

When the CAN-CANFD gateway is enabled, do not perform routing for the following frames.

- CANFD frames with a payload length of more than 8 bytes
- Remote frames

When the CAN-CANFD gateway is enabled, the following frame should be transmitted in the channel by setting of GWFDF.

- When GWFDF bit is set to 0, only classical CAN frames should be transmitted.
- When GWFDF bit is set to 1, only CANFD frames should be transmitted.

28.10 Test Function

The test function is classified into communication tests and global tests.

- Communication tests: Performed for each channel.
 - Standard test mode
 - Listen-only mode
 - Self-test mode 0 (external loopback mode)
 - Self-test mode 1 (internal loopback mode)
 - Restricted operation mode (only in CANFD mode)
- Global tests: Performed for the entire module
 - RAM test (read/write test)
 - Inter-channel communication test [CRC error test enabled]

28.10.1 Standard Test Mode

CRC tests are enabled in standard test mode. The CRC value calculated by the RS-CANFD module based on the transmit message or receive message is stored in the register. This CRC value is stored in the CRCREG[14:0] bits in the RSCFDn(CFD)CmERFL register when the message is a classical CAN frame (CRC length = 15 bits) or in the CRCREG[20:0] bits in the RSCFDnCFDCmFDCRC register when the message is a CANFD frame (CRC length = 17 or 21 bits). Use the inter-channel communication test function for CRC error tests. For details, see **Section 28.10.6.1, CRC Error Test**.

28.10.2 Listen-Only Mode

Listen-only mode allows reception of data frames and remote frames. Only recessive bits are transmitted on the CAN bus, and the ACK bit, overload flag, and active error flag are not transmitted.

Listen-only mode is available for detecting the communication speed.

Do not make a transmit request from any buffer or queue in listen-only mode.

Figure 28.12 shows the connection when listen-only mode is selected.

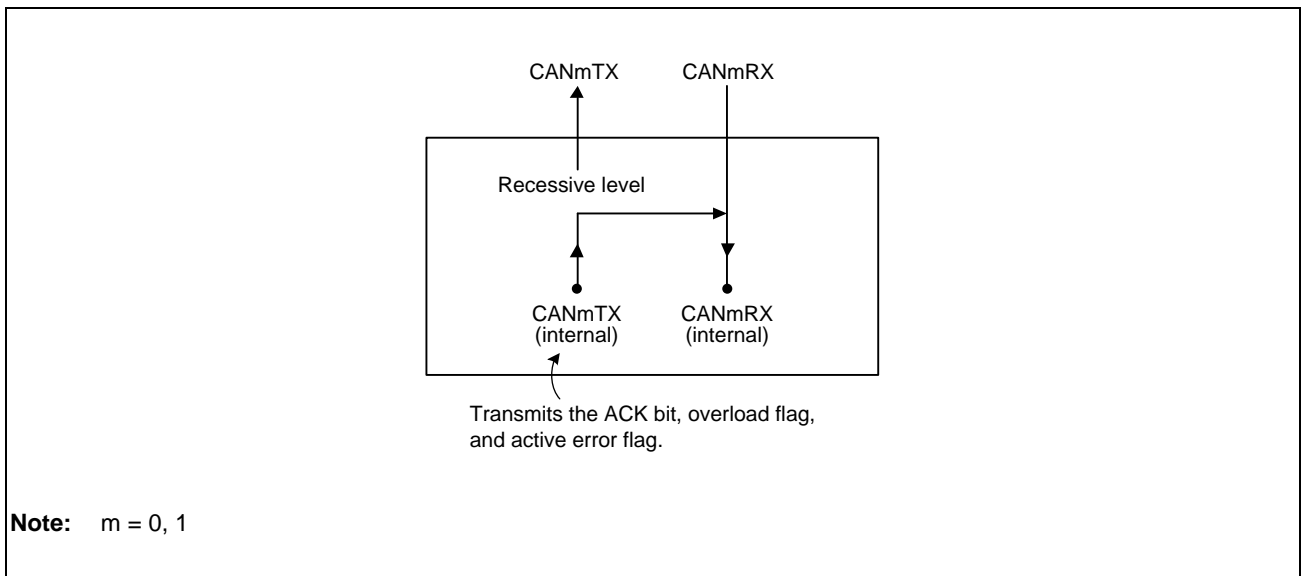

Figure 28.12 Connection when Listen-Only Mode is Selected

28.10.3 Self-Test Mode (Loopback Mode)

In self-test mode, transmitted messages are compared with the receive rule of the own channel and the messages are stored in a buffer if they have passed through the filter processing. Messages transmitted from other CAN nodes are compared only with the receive rule for which the GAFLLB bit in the RSCFDn(CFD)GAFLIDj register (j = 0 to 15) is set to 0 (when a message transmitted from another CAN node is received).

If the mirror function and self-test mode are both enabled, the self-test mode setting takes precedence.

28.10.3.1 Self-Test Mode 0 (External Loopback Mode)

Self-test mode 0 is used to perform a loopback test within a channel including the CAN transceiver.

In self-test mode 0, transmitted messages are handled as messages received through the CAN transceiver and are stored in a buffer. An ACK bit is generated to receive messages transmitted from the own CAN node.

Figure 28.13 shows the connection when self-test mode 0 is selected.

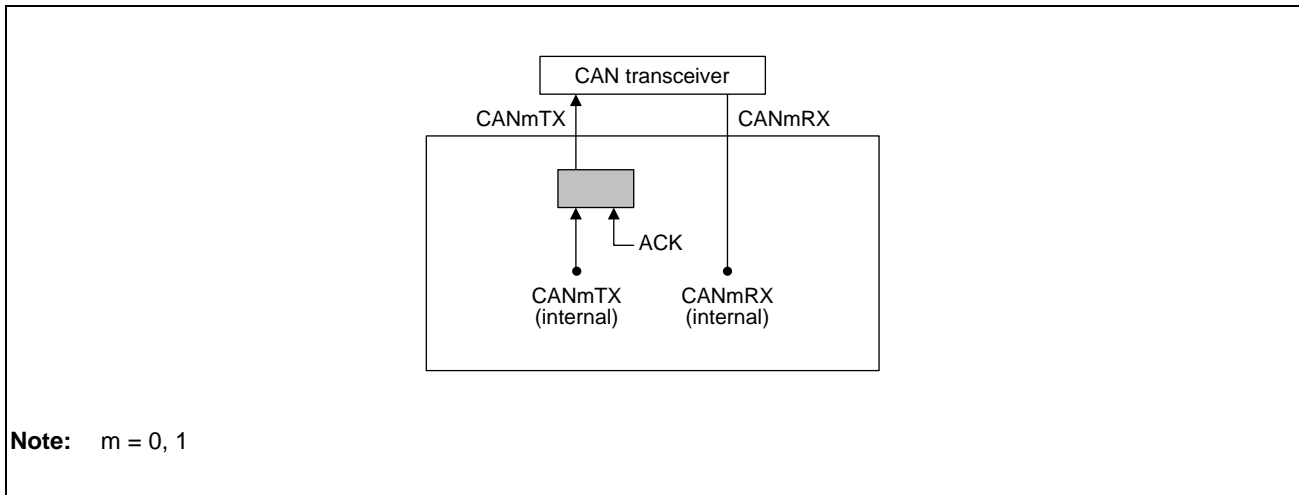

Figure 28.13 Connection when Self-Test Mode 0 is Selected

28.10.3.2 Self-Test Mode 1 (Internal Loopback Mode)

In self-test mode 1, transmitted messages are handled as received messages and are stored in a buffer. An ACK bit is generated to receive messages transmitted from the own CAN node.

In self-test mode 1, internal feedback from the internal CANmTX pin ($m = 0, 1$) to the internal CANmRX pin is performed. The external CANmRX pin input is isolated. The external CANmTX pin outputs only recessive bits.

Figure 28.14 shows the connection when self-test mode 1 is selected.

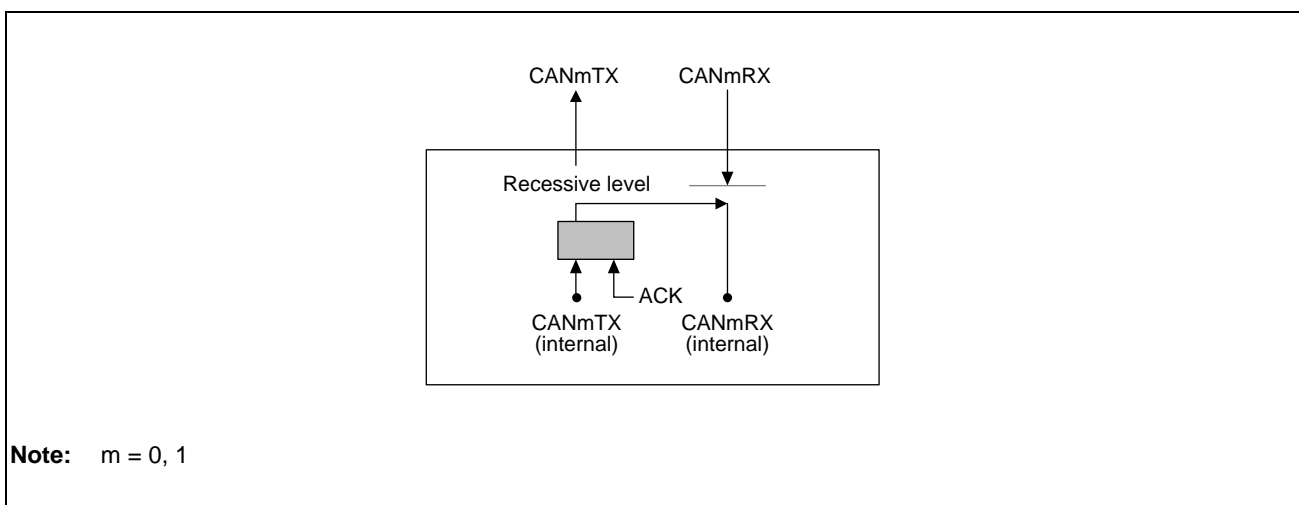

Figure 28.14 Connection when Self-Test Mode 1 is Selected

28.10.4 Restricted Operation Mode (Only in CANFD Mode)

In restricted operation mode, an ACK bit is generated when a valid data frame and a remote frame have been received, but these frames are not transmitted even if an error frame or an overload frame transmit condition is detected. When a condition is detected, operation is suspended until the bus idle state comes for resynchronization with the CAN communication. The receive error counter (REC) and the transmit error counter (TEC) do not change due to an error.

A desired transmission request can be made for transmission without restrictions.

28.10.5 RAM Test

The RAM test function allows accesses to all CAN RAM addresses.

When the RAM test function is used, the RAM is divided into pages of 256 bytes each. RAM test page is set by the RTMPS[6:0] bits in the RSCFDn(CFD)GTSTCFG register. Data in the set page can be read from and written to the RSCFDn(CFD)RPGACCr register (r = 0 to 63). The available total RAM size is 5120 bytes (H'1400) in classical CAN mode or 7104 bytes (H'1BC0) in CANFD mode. Do not access the RAM area higher than the 192th byte on the last page (the setting of the RTMPS bit is H'1B) in CANFD mode.

28.10.6 Inter-Channel Communication Test

The inter-channel communication test function allows communication test by internally connecting CAN channels to each other. During this test, channels are isolated from the external CAN bus.

Before starting data transmission/reception in channel communication mode, make transmission/reception settings for each channel.

Figure 28.15 shows the connection for inter-channel communication test.

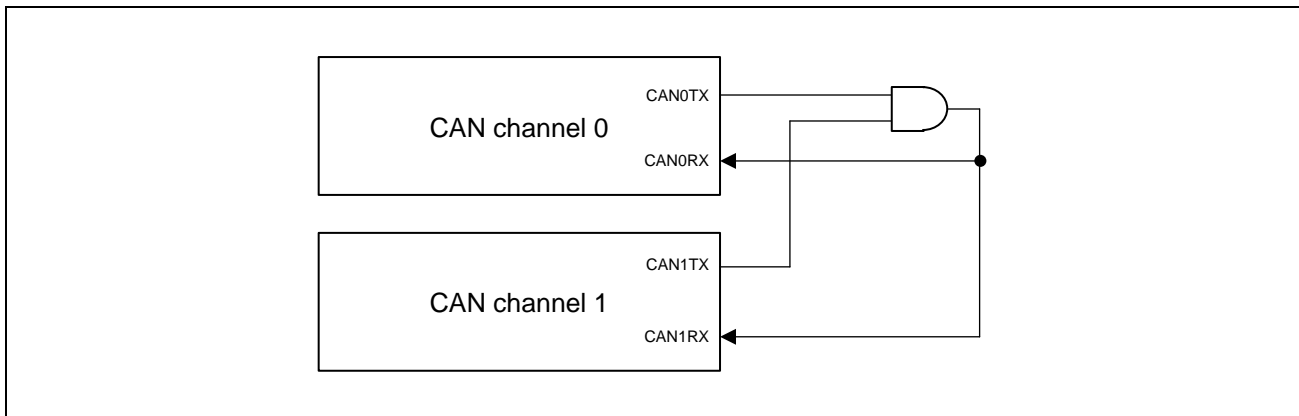

Figure 28.15 Connection for Inter-Channel Communication Test

28.10.6.1 CRC Error Test

A CRC error test is enabled during an inter-channel communication test. The following shows an example of channel 0 CRC error test procedure during a communication test between channel 0 and channel 1.

Preconditions

- Inter-channel communication test is enabled.
- Channel 0 and channel 1 are in standard test mode.

Procedure

1. Make a setting to send a message from the transmit buffer p of channel 1.
2. Set the CRCT bit in the RSCFDn(CFD)C0CTR register to 1 (to enable inversion of the first bit in the received ID field).
3. Set the TMTR bit in the RSCFDn(CFD)TMCp register to 1 (to issue a transmission request to the transmit buffer p of channel 1).
4. Wait for occurrence of a CAN0 error interrupt due to a channel bus error.
5. Read the CRCREG[14:0] bits in the RSCFDn(CFD)CmERFL register or the CRCREG[20:0] bits in the RSCFDnCFDCmFDCRC register of channel 0 and channel 1, and confirm that the CRC values are different on the transmission and the reception side.
6. Confirm that the CERR bit in RSCFDm(CFD)C0ERFL is 1 (CRC error detected).

The CRC error test function generates an incorrect CRC value by inverting the first bit in the received ID field. Therefore, note that not a CRC error but a stuff error (continuous 6-bit data of the same level) is detected when a message in which ID's upper 5-bit value is 10000b or ID's upper 6-bit value is 011111b is received.

The CRC generation circuit of the RS-CANFD module is contained in the protocol controller of each channel. Another CRC calculation test is not necessary during transmission because the same circuit is used for both transmission and reception.

28.11 RS-CANFD Setting Procedure

28.11.1 Initial Settings

The RS-CANFD module initializes the CAN RAM after the MCU is reset. The RAM initialization time is 2530 cycles of the pclk. The GRAMINIT flag in the RSCFDn(CFD)GSTS register is set to 1 (CAN RAM initialization is ongoing) during the RAM initialization and is cleared to 0 (CAN RAM initialization is finished) when the initialization is completed. Make CAN settings after the GRAMINIT flag is cleared to 0. **Figure 28.16** shows the CAN setting procedure after the MCU is reset.

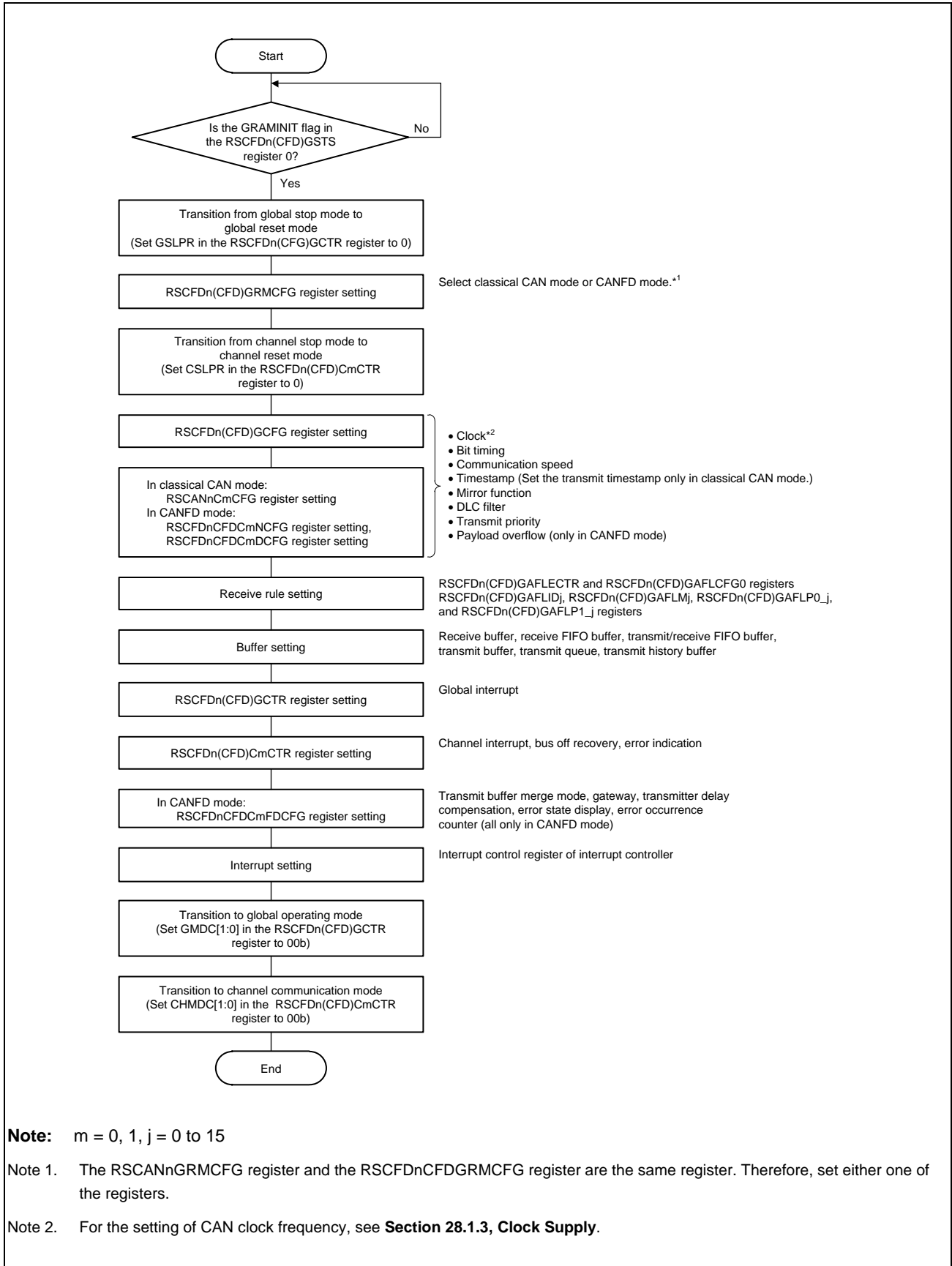

Figure 28.16 CAN Setting Procedure after the MCU is Reset

28.11.1.1 Clock Setting

Set the CAN clock (fCAN) as a clock source of the RS-CANFD module. Select the clk_xincan or clk using the DCS bit in the RSCFDn(CFD)GCFG register.

28.11.1.2 Bit Timing Setting

In the CAN protocol, one bit of a communication frame consists of three segments SS, TSEG1, and TSEG2, of which two segments TSEG1 and TSEG2 can be set by the corresponding registers for each channel. In classical CAN mode, set these two segments in the RSCANnCMCFG register. Two bit rates (nominal bit rate and data bit rate) are provided for CANFD mode. Set the nominal bit rate in the RSCFDnCFDCmNCFG register and set the data bit rate in the RSCFDnCFDCmDCFG register. Sample point timing can be determined by setting these two segments. This timing can be adjusted in units of 1 Time Quantum (hereafter referred to as Tq). A single Tq is the cycle of clock obtained by dividing the clock selected by the DCS bit in the RSCFDn(CFD)GCFG register. Set a division ratio by the BRP[9:0] bits in the RSCANnCMCFG register in classical CAN mode (CANmTq clock), and by the NBRP[9:0] bits in the RSCFDnCFDCmNCFG register and the DBRP[7:0] bits in the RSCFDnCFDCmDCFG register in CANFD mode (CANmTq(N) clock and CANmTq(D) clock). Be sure to specify the same values for both NBRP[9:0] and DBRP[7:0]. To specify different values for the nominal bit rate and the data bit rate, change the values of the RSCFDnCFDCmNCFG.NTSEG1 and NTSEG2 bits and RSCFDnCFDCmDCFG.DTSEG1 and DTSEG2 bits, respectively.

When the TDCE bit is set to 1 (Transmitter delay compensation is enabled) in the RSCFDnCFDCmFDCFG register, set the equal value of 1 or less to the bits NBRP[9:0] and DBRP[7:0].

Figure 28.17 shows the bit timing chart. **Table 28.40** shows an example of bit timing setting.

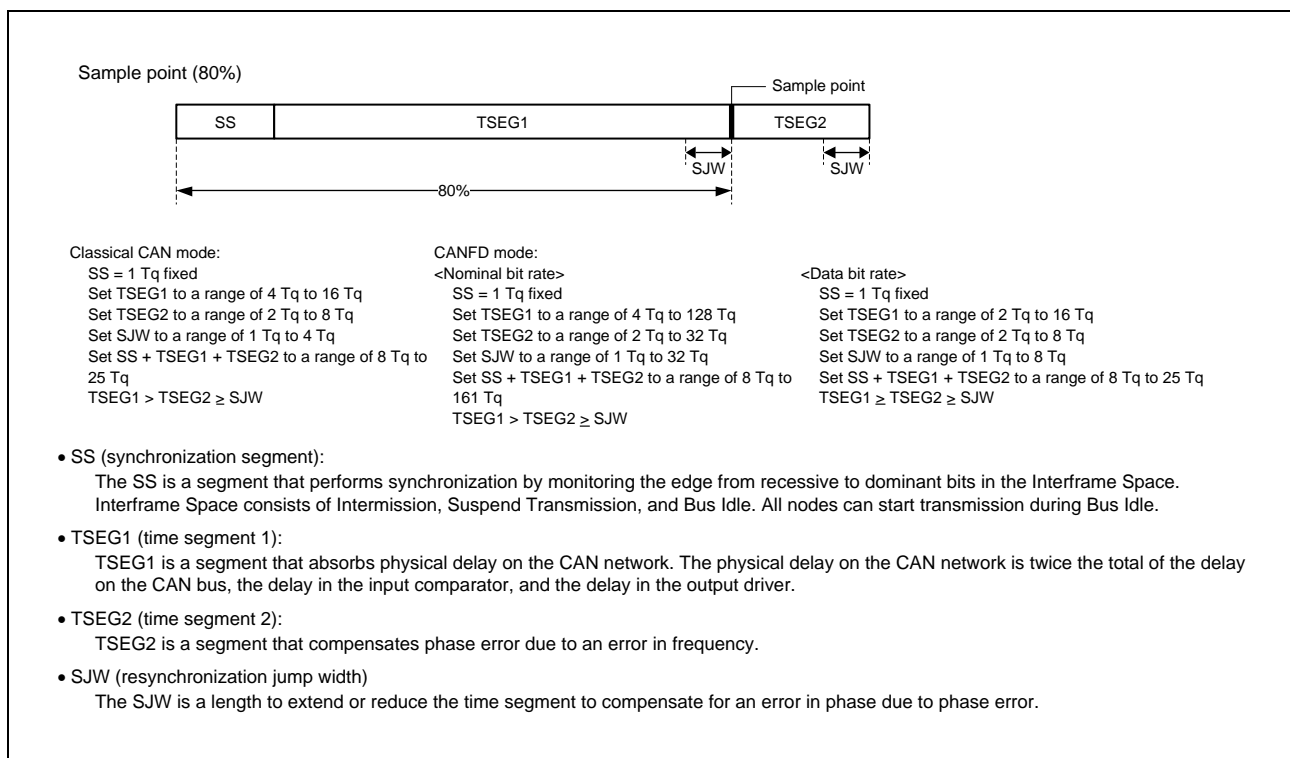

Figure 28.17 Bit Timing Chart

Table 28.40 Example of Bit Timing Setting

1 Bit	Set Value (Tq)				Sample Point (%)
	SS	TSEG1	TSEG2	SJW	<i>Note:</i> See Figure 28.17 .
	1	4	3	1	62.50
8 Tq	1	5	2	1	75.00
	1	6	3	1	70.00
10 Tq	1	7	2	1	80.00
	1	10	5	1	68.75
16 Tq	1	11	4	1	75.00
	1	12	7	1	65.00
20 Tq	1	13	6	1	70.00
50 Tq* ¹	1	39	10	4	80.00

Note 1. Only in CANFD mode

28.11.1.3 Communication Speed Setting

Set the CAN communication speed for each channel using the fCAN, baud rate prescaler division value, and Tq count per bit time. For CANFD mode, set two types of transmission rate (arbitration phase and data phase) for each channel.

Figure 28.18 shows the CAN clock control block diagram, and **Table 28.41** and **Table 28.42** show examples of the communication speed setting.

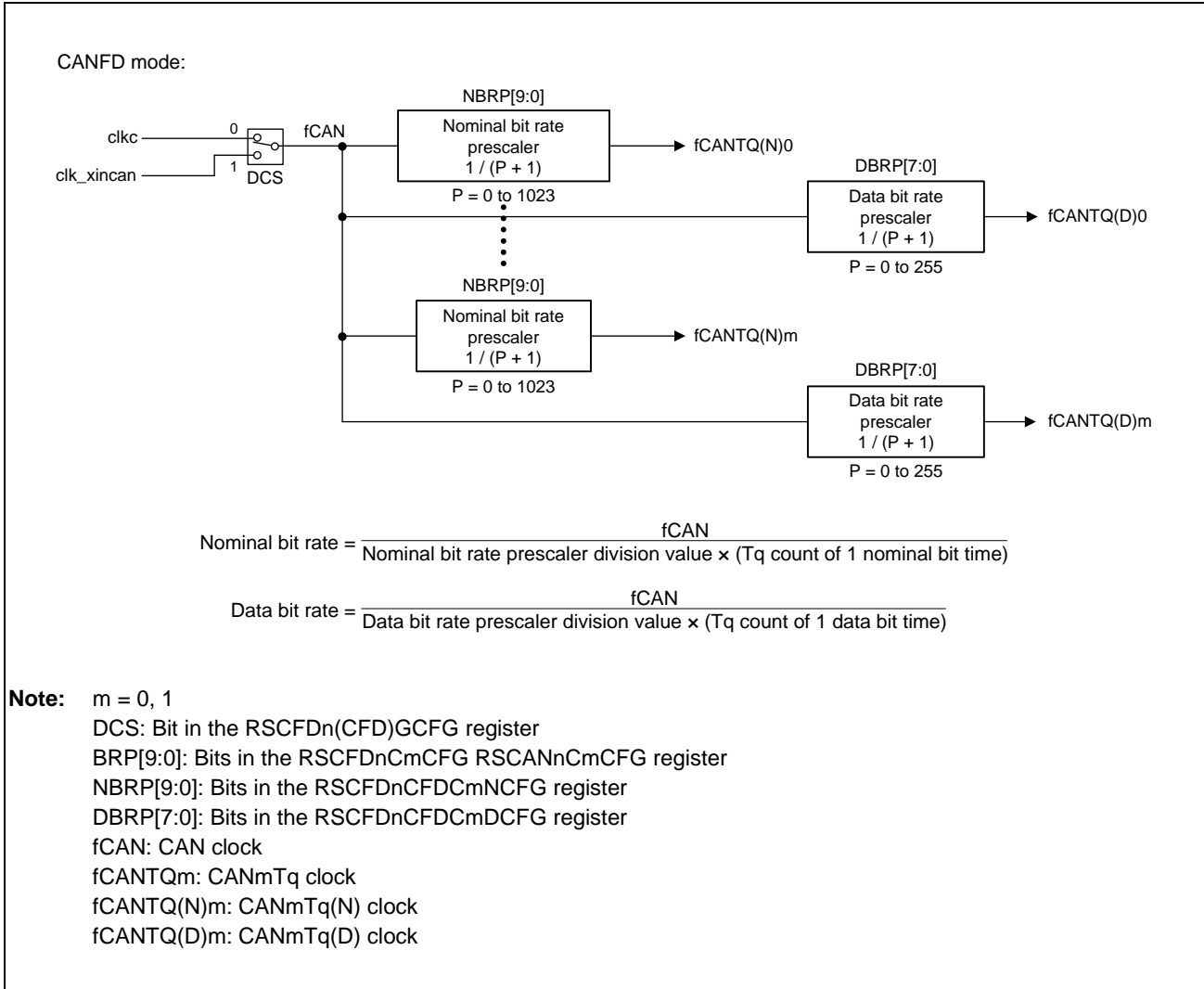

Figure 28.18 CAN Clock Control Block Diagram

Table 28.41 Example of Communication Speed Setting (Classical CAN Mode)

Communication Speed	fCAN		
	32 MHz	16 MHz	8 MHz
1 Mbps	8 Tq (4) 16 Tq (2)	8 Tq (2) 16 Tq (1)	8 Tq (1)
500 Kbps	8 Tq (8) 16 Tq (4)	8 Tq (4) 16 Tq (2)	8 Tq (2) 16 Tq (1)
250 Kbps	8 Tq (16) 16 Tq (8)	8 Tq (8) 16 Tq (4)	8 Tq (4) 16 Tq (2)
125 Kbps	8 Tq (32) 16 Tq (16)	8 Tq (16) 16 Tq (8)	8 Tq (8) 16 Tq (4)

Table 28.42 Example of Transmission Rate Setting (Nominal Bit Rate and Data Bit Rate in CANFD Mode)

Communication Speed	fCAN	
	32 MHz	16 MHz
Nominal bit rate 1 Mbps Data bit rate 4 Mbps	Nominal bit rate 32 Tq (1) Data bit rate 8 Tq (1)	None
Nominal bit rate 500 Kbps Data bit rate 2 Mbps	Nominal bit rate 64 Tq (1) Data bit rate 16 Tq (1)	Nominal bit rate 32 Tq (1) Data bit rate 8 Tq (1)

Note: Values in () are baud rate prescaler division values.

28.11.1.4 Receive Rule Setting

Receive rules can be set using receive rule-related registers.

Up to 16 receive rules can be registered per page. Specify pages 0 to 23 (for 6-channel unit) by the AFLPN[4:0] bits in the RSCFDn(CFD)GAFLECTR register. Set receive rule table write enable/disable using the AFLDAE bit.

Figure 28.19 shows the receive rule setting procedure.

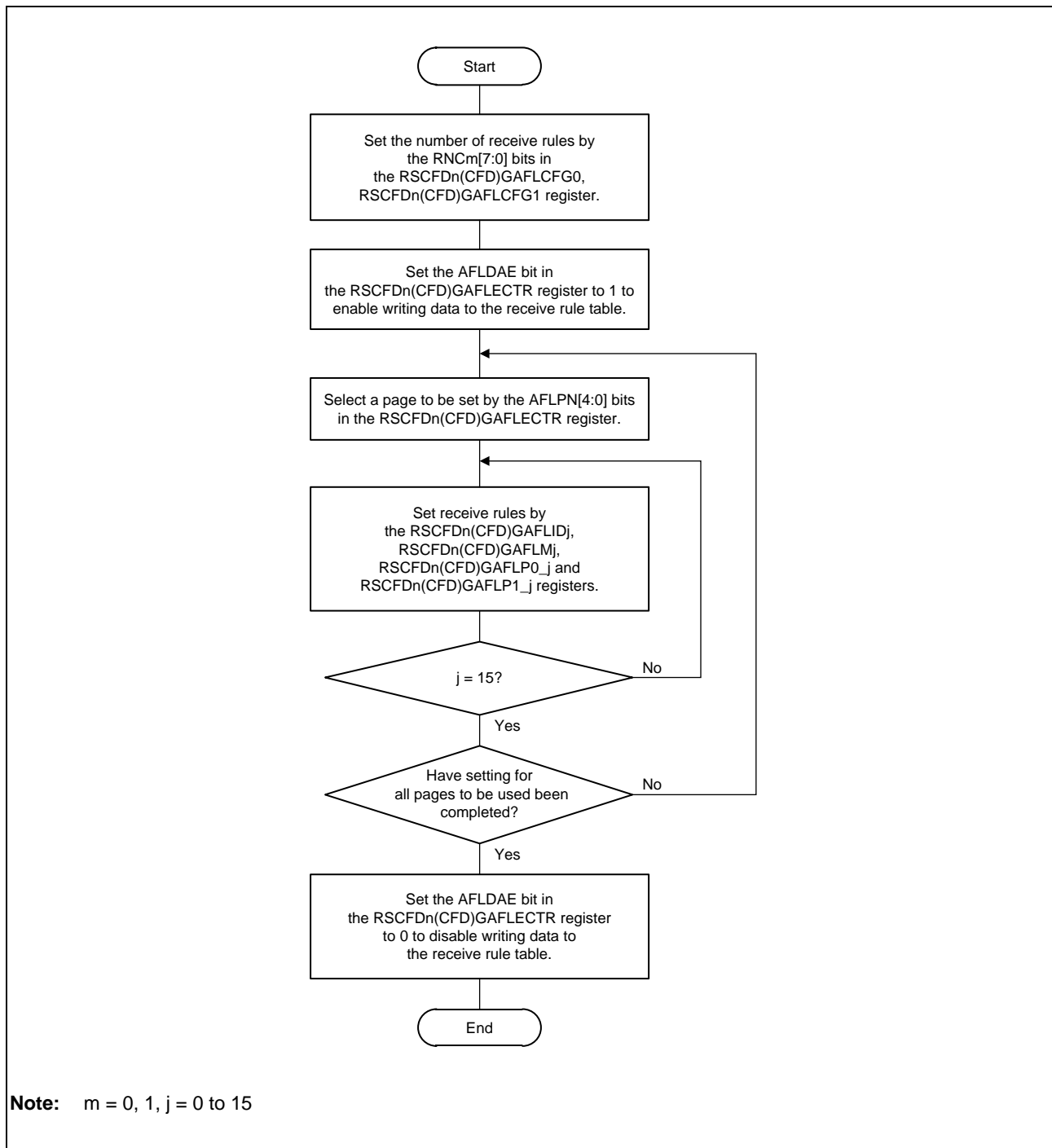

Figure 28.19 Receive Rule Setting Procedure

28.11.1.5 Buffer Setting

Set the number of buffers to be used (number of messages to be stored) and interrupt sources. Also set the payload storage size for CANFD mode. For transmit/receive FIFO buffers that are set to transmit mode, set transmit buffers to be linked.

In classical CAN mode, up to 2048 bytes of the RAM can be used in receive buffers and FIFO buffers. Up to 128 buffers are available, and 16 bytes are used per buffer. Configure the buffers so that the following conditions are met.

$$\text{Number of receive buffers} + \text{total number of depth of receive FIFO buffers} \times \text{total number of depth of transmit/receive FIFO buffers} \leq 128 \text{ buffers}$$

In CANFD mode, up to 3584 bytes of the RAM can be used in receive buffers and FIFO buffers. Configure the buffers so that the following conditions are met.

$$\text{Number of receive buffers} \times (12 + \text{payload storage size}) + \text{total of (number of depth} \times (12 + \text{payload storage size})) \text{ of receive FIFO buffers} \times \text{total of (number of depth} \times (12 + \text{payload storage size})) \text{ of transmit/receive FIFO buffers} \leq 3584 \text{ bytes}$$

Figure 28.20 shows the buffer configuration. **Figure 28.21** shows the buffer setting procedure.

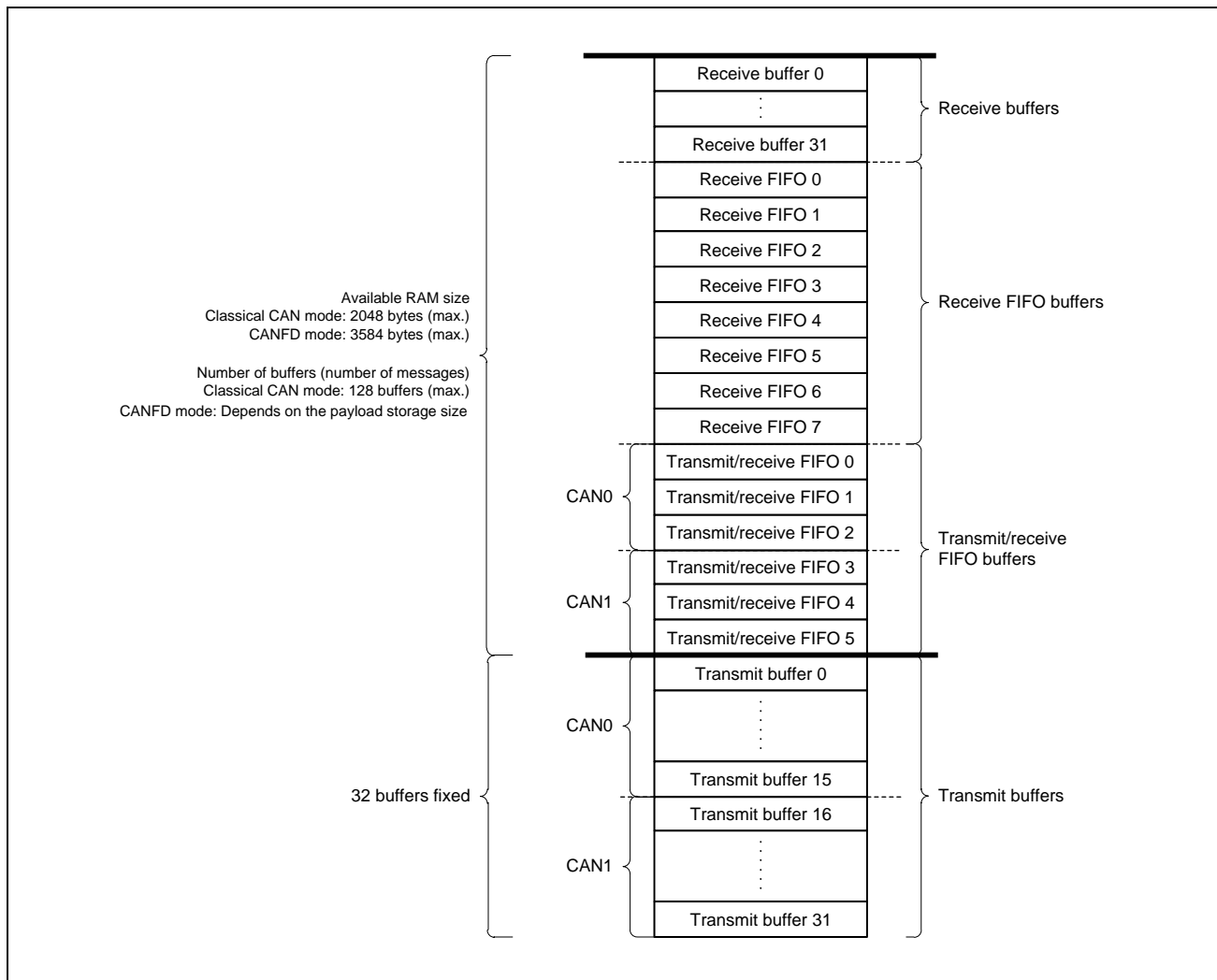

Figure 28.20 Buffer Configuration

NOTE

Receive buffers, receive FIFO buffers, transmit/receive FIFO buffers, and transmit buffers are located in succession.

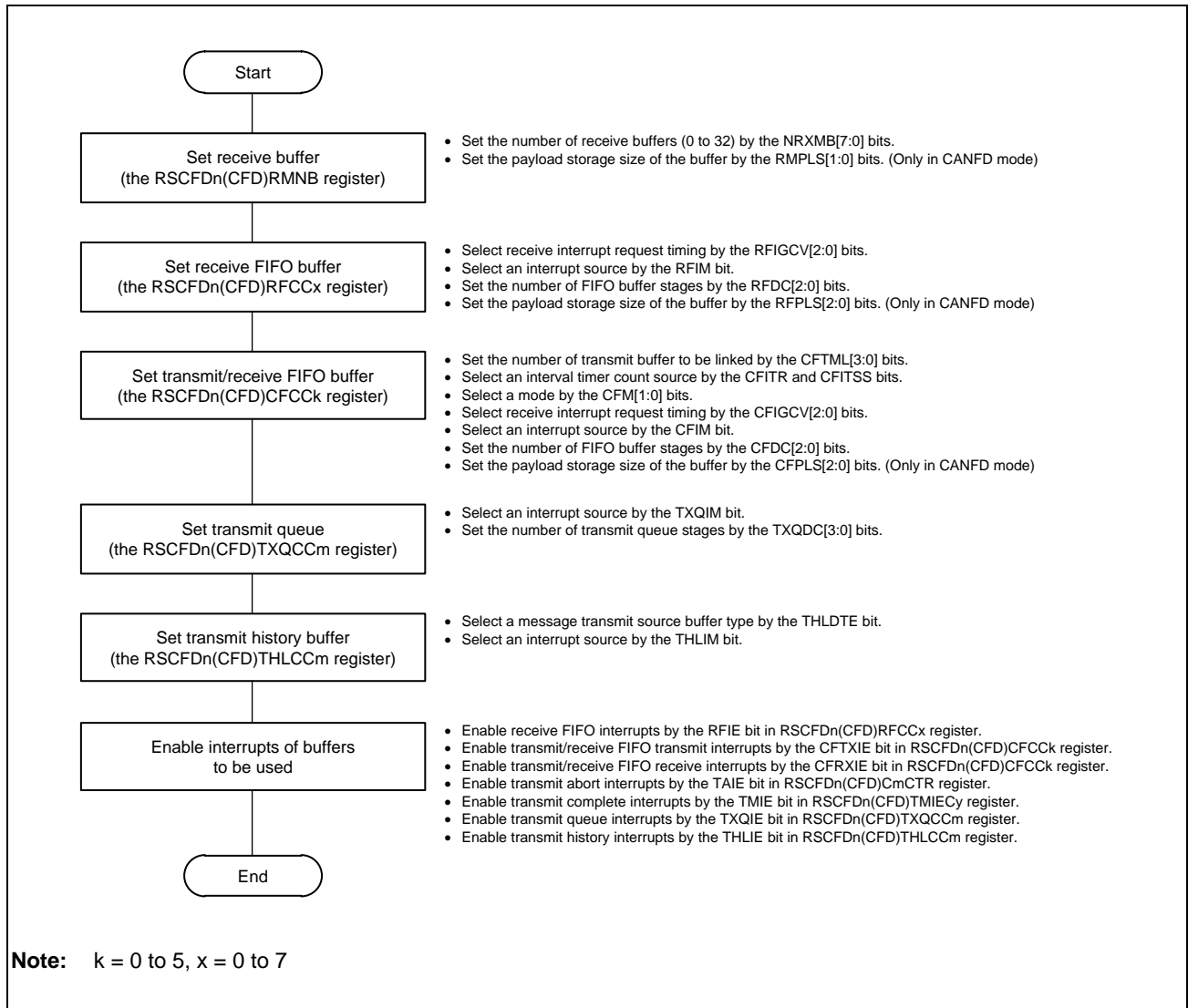

Figure 28.21 Buffer Setting Procedure

28.11.1.6 Transmitter Delay Compensation (Only in CANFD Mode)

A high baud rate is used in CANFD mode. Transmitter delay compensation is provided as a function to accept propagation delay in this case.

To use this function, set the TDCE bit in the RSCFDnCFDCmFDCFG register to 1. Also set the secondary sample point (SSP) timing used in the data phase by the TDCOC bit and TDCO[6:0] bits in the RSCFDnCFDCmFDCFG register.

When the TDCOC bit is 0, the SSP timing equals the total value of the delay measured by the RS-CANFD module and the TDCO[6:0] value. (This value is rounded off to the nearest integer of T_q .) Usually, the TDCO[6:0] value must be equal to SS + TSEG1, the sample point timing.

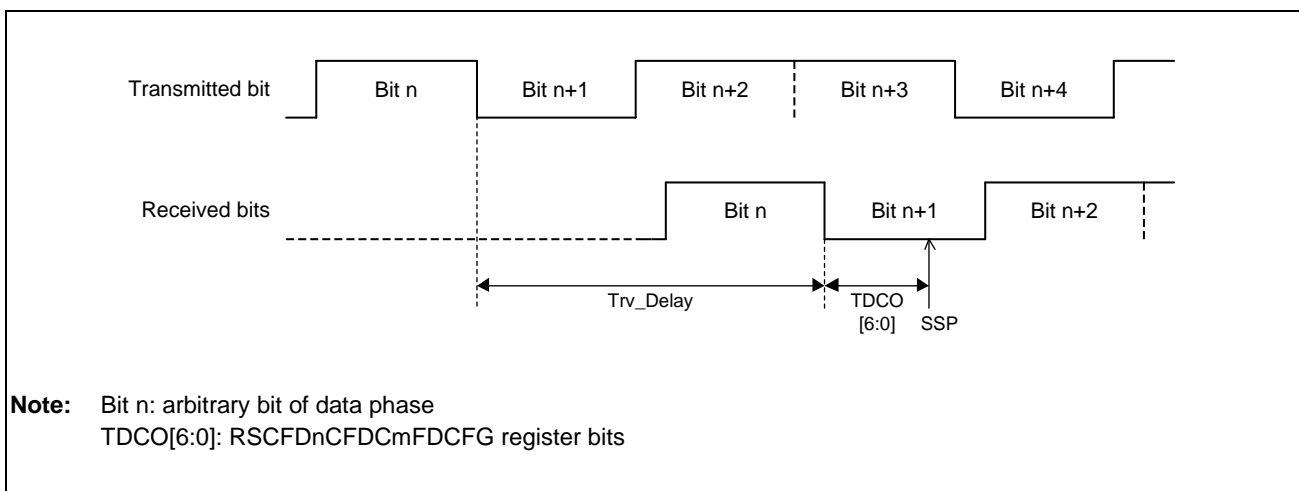

Figure 28.22 SSP Timing

When the TDCOC bit is 1, the SSP timing is determined only by the TDCO[6:0] value. (When the DBRP[7:0] value in the RSCFDnCFDCmDCFG register is larger than 0, the TDCO[6:0] value is also rounded off to the nearest integer of T_q .)

The RS-CANFD module compensates a delay up to $(3 \text{ CANm bit time} - 2 T_q)$. (Both CANm bit time and T_q are data bit rate values.)

When the TDCE bit in RSCFDnCFDCmFDCFG register is 1 (transmitter delay compensation is enabled), set bits NBRP[9:0] and DBRP[7:0] to the same value that is less than 1.

28.11.2 Reception Procedure

28.11.2.1 Receive Buffer Reading Procedure

When the processing to store received messages in a receive buffer starts, the RMNSq flag in the RSCFDn(CFD)RMNDy register (y = 0, q = 0 to 31) is set to 1 (receive buffer q contains a new message). Messages can be read from registers RSCFDn(CFD)RMIDq, RSCFDn(CFD)RMPTRq, RSCFDnCFDRMFDSTSq (only in CANFD mode), and RSCFDn(CFD)RMDfb_q (b = 0 or 1 in classical CAN mode, b = 0 to 4 in CANFD mode). **Figure 28.23** shows the receive buffer reading procedure. This procedure ensures the consistency of messages read from registers RSCFDn(CFD)RMIDq, RSCFDn(CFD)RMPTRq, RSCFDnCFDRMFDSTSq, and RSCFDn(CFD)RMDfb_q.

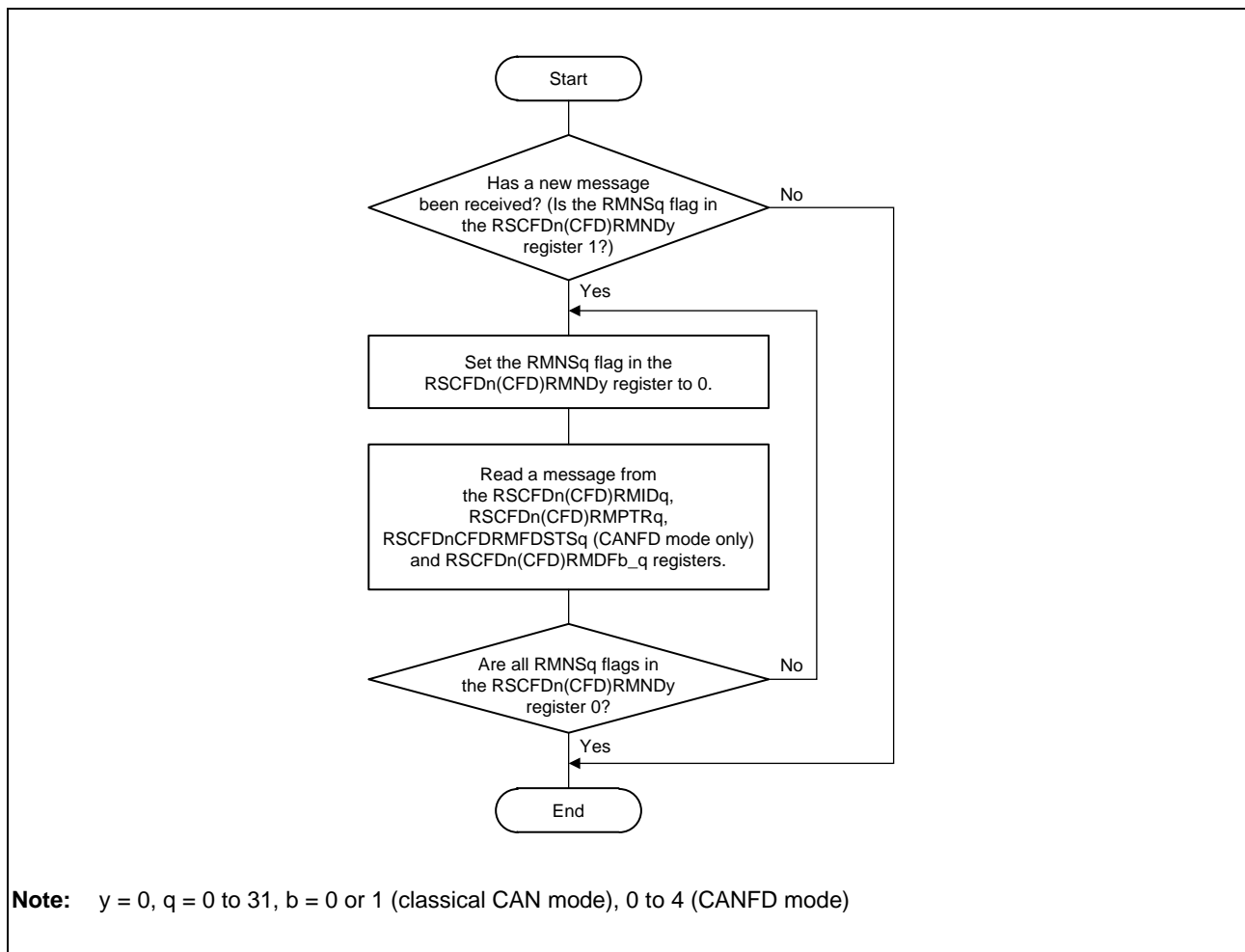

Figure 28.23 Receive Buffer Reading Procedure

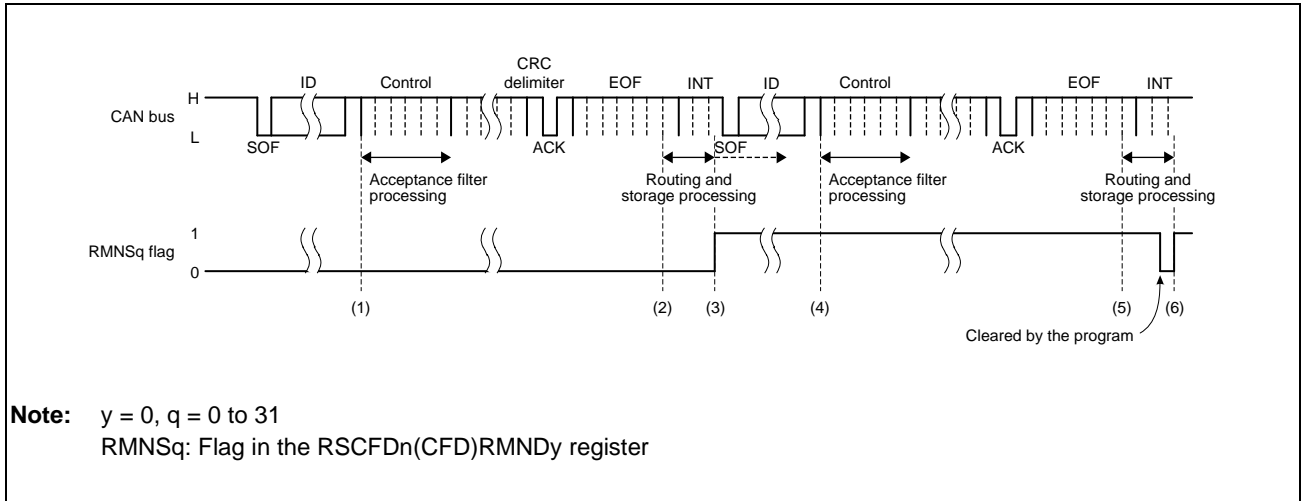

Figure 28.24 Receive Buffer Reception Timing Chart

- (1) When the ID field in a message has been received, the acceptance filter processing starts.
- (2) When the message matches the receive rule of the corresponding channel and the message has been successfully received, the routing processing to transfer the message to the specified buffer starts. When the DCE bit in the RSCFDn(CFD)GCFG register is set to 1 (DLC check is enabled), the DLC filter processing starts at this time.
- (3) When the message has passed through the DLC filter processing, the processing to store the message in the specified receive buffer starts.
When the message storage processing starts, the RMNSq flag in the corresponding RSCFDn(CFD)RMNDy register is set to 1 (the receive buffer contains a new message). If other channels are performing filter processing or transmit priority determination processing, the routing processing and the storage processing may be delayed.
- (4) When the ID field of the next message has been received, the acceptance filter processing starts.
- (5) When the message matches the receive rule of the corresponding channel and the message has been successfully received, the routing processing to transfer the message to the specified buffer starts. When the DCE bit in the RSCFDn(CFD)GCFG register is set to 1 (DLC check is enabled), the DLC filter processing starts at this time.
- (6) When the corresponding RMNSq flag is cleared to 0 (the receive buffer contains no new message), this flag is set to 1 again when the message storage processing starts. Even if the RMNSq flag remains 1, a new message is overwritten to the receive buffer. The RMNSq flag should not be cleared to 0 during storage of messages.

28.11.2.2 FIFO Buffer Reading Procedure

When received messages have been stored in one or more receive FIFO buffers or a transmit/receive FIFO buffer that is set to receive mode or gateway mode, the corresponding message count display counter (RFMC[7:0] bits in the RSCFDn(CFD)RFSTSx register (x = 0 to 7) or CFMC[7:0] bits in the RSCFDn(CFD)CFSTS_k register (k = 0 to 17)) is incremented. At this time, when the RFIE bit (receive FIFO interrupt is enabled) in the RSCFDn(CFD)RFCCx register or the CFRXIE bit (transmit/receive FIFO receive interrupt is enabled) in the RSCFDn(CFD)CFCCk register is set to 1, an interrupt request is generated. Received messages can be read from the RSCFDn(CFD)RFIDx, RSCFDn(CFD)RFPTRx, RSCFDn(CFD)RFFDSTSx (only in CANFD mode), and RSCFDn(CFD)RFDFd_x (d = 0 or 1 in classical CAN mode, d = 0 to 15 in CANFD mode) registers for receive FIFO buffers, or from the RSCFDn(CFD)CFIDk, RSCFDn(CFD)CFPTRk, RSCFDn(CFD)CFDCFFDCSTS_k (only in CANFD mode), and RSCFDn(CFD)CFDFd_k registers for transmit/receive FIFO buffers. Messages in FIFO buffers can be read sequentially on a first-in, first-out basis.

When the message count display counter value matches the FIFO buffer depth (a value set by the RFDC[2:0] bits in the RSCFDn(CFD)RFCCx register or the CFDC[2:0] bits in the RSCFDn(CFD)CFCCk register), the RFFLL or CFFLL flag is set to 1 (the receive FIFO buffer is full).

When all messages have been read out of the FIFO buffer, the RFEMP flag in the RSCFDn(CFD)RFSTSx register or the CFEMP flag in the RSCFDn(CFD)CFSTS_k register is set to 1 (the receive FIFO buffer contains no unread message (buffer empty)).

If the RFE bit or the CFE bit is cleared to 0 (no receive FIFO buffer is used) with the interrupt request flag (RFIF flag in the RSCFDn(CFD)RFSTSx register or CFRXIF flag in the RSCFDn(CFD)CFSTS_k register) set to 1 (a receive FIFO interrupt request is present), the interrupt request flag is not automatically cleared to 0. The program must clear the interrupt request flag to 0.

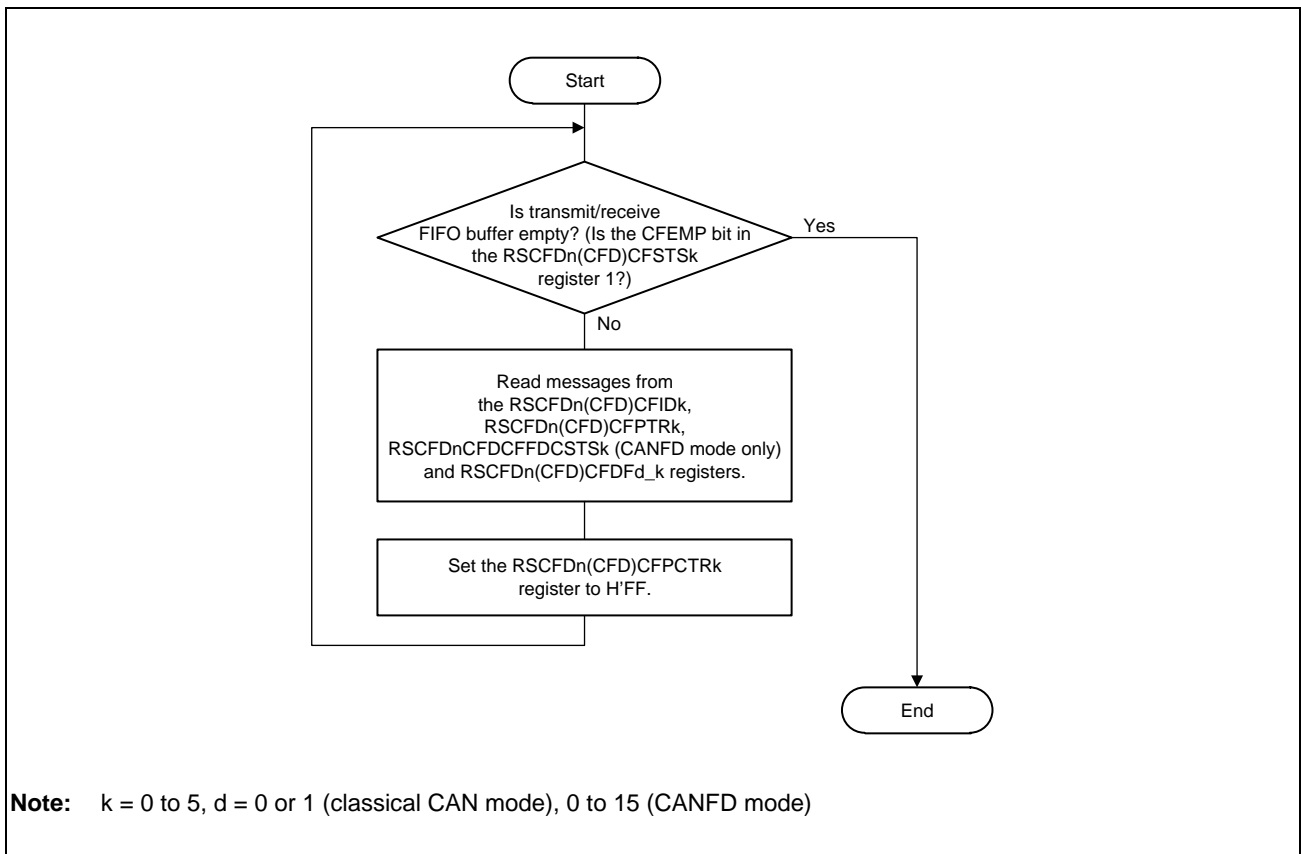

Figure 28.25 Transmit/Receive FIFO Buffer Reading Procedure

When reading a message in CANFD mode, do not read the RSCFDnCFDRFDFd_x or RSCFDnCFDCFDFd_k register corresponding to the area exceeding the payload storage size specified by the RFPLS[2:0] bits in the RSCFDnCFDRFCCx register or the CFPLS[2:0] bits in the RSCFDnCFDCFCCK register.

Table 28.43 Payload Storage Area of Receive FIFO Buffer

Set RFPLS[2:0] Value	Payload Storage Size	Corresponding Data Field Registers
000b	8 bytes	RSCFDnCFDRFDF0_x to RSCFDnCFDRFDF1_x
001b	12 bytes	RSCFDnCFDRFDF0_x to RSCFDnCFDRFDF2_x
010b	16 bytes	RSCFDnCFDRFDF0_x to RSCFDnCFDRFDF3_x
011b	20 bytes	RSCFDnCFDRFDF0_x to RSCFDnCFDRFDF4_x
100b	24 bytes	RSCFDnCFDRFDF0_x to RSCFDnCFDRFDF5_x
101b	32 bytes	RSCFDnCFDRFDF0_x to RSCFDnCFDRFDF7_x
110b	48 bytes	RSCFDnCFDRFDF0_x to RSCFDnCFDRFDF11_x
111b	64 bytes	RSCFDnCFDRFDF0_x to RSCFDnCFDRFDF15_x

Table 28.44 Payload Storage Area of Transmit/Receive FIFO Buffer

Set CFPLS[2:0] Value	Payload Storage Size	Corresponding Data Field Registers
000b	8 bytes	RSCFDnCFDCFDF0_k to RSCFDnCFDCFDF1_k
001b	12 bytes	RSCFDnCFDCFDF0_k to RSCFDnCFDCFDF2_k
010b	16 bytes	RSCFDnCFDCFDF0_k to RSCFDnCFDCFDF3_k
011b	20 bytes	RSCFDnCFDCFDF0_k to RSCFDnCFDCFDF4_k
100b	24 bytes	RSCFDnCFDCFDF0_k to RSCFDnCFDCFDF5_k
101b	32 bytes	RSCFDnCFDCFDF0_k to RSCFDnCFDCFDF7_k
110b	48 bytes	RSCFDnCFDCFDF0_k to RSCFDnCFDCFDF11_k
111b	64 bytes	RSCFDnCFDCFDF0_k to RSCFDnCFDCFDF15_k

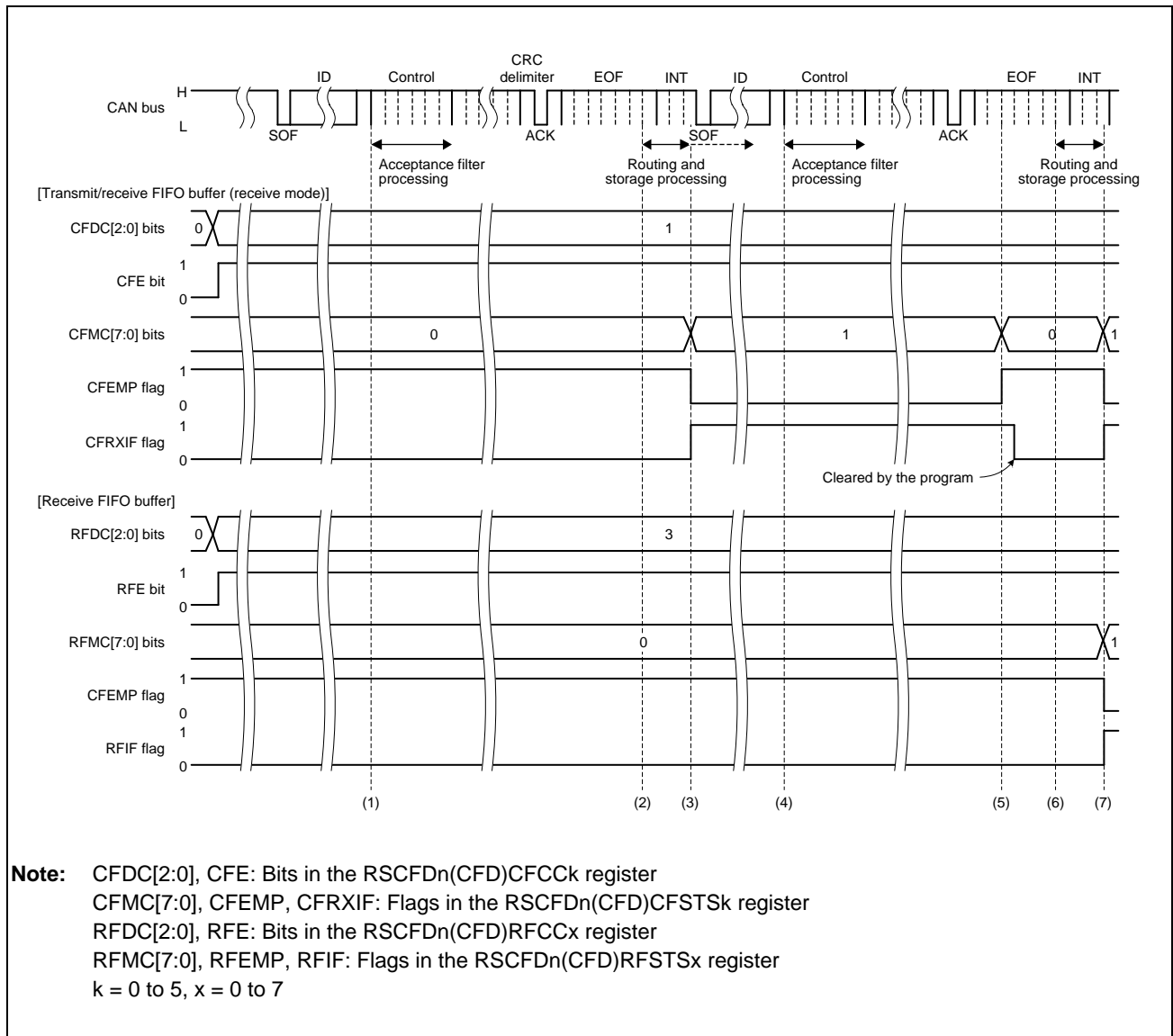

Figure 28.26 FIFO Buffer Reception Timing Chart

- (1) When the ID field in a message has been received, the acceptance filter processing starts.
- (2) When the message matches the receive rule of the corresponding channel and the message has been successfully received, the routing processing to transfer the message to the specified buffer starts. When the DCE bit in the RSCFDn(CFD)GCFG register is set to 1 (DLC check is enabled), the DLC filter processing starts at this time.
- (3) When the message has passed through the DLC filter processing and the CFE bit in the RSCFDn(CFD)CFCCk register is 1 (transmit/receive FIFO buffers are used) and the CFDC[2:0] value in the RSCFDn(CFD)CFCCk register is 001b or more, the message is stored in the transmit/receive FIFO buffer that is set to receive mode. The CFMC[7:0] value in the RSCFDn(CFD)CFSTSk register is incremented and becomes H'01. When the CFIM bit in the RSCFDn(CFD)CFCCk register is set to 1 (a FIFO receive interrupt request is generated each time a message has been received), the CFRXIF flag in the RSCFDn(CFD)CFSTSk register is set to 1 (a transmit/receive FIFO receive interrupt request is present). The CFRXIF flag can be reset to 0 by the program.
- (4) When the ID field of the next message has been received, the acceptance filter processing starts.

- (5) Read received messages from the RSCFDn(CFD)CFIDk, RSCFDn(CFD)CFPTRk, and RSCFDn(CFD)CFDFd_k registers and write H'FF to the RSCFDn(CFD)CFPCTRk register. This causes the CFMC[7:0] bits in the RSCFDn(CFD)CFSTSk register to be decremented. When CFMC[7:0] becomes H'00, the CFEMP flag in the RSCFDn(CFD)CFSTSk register becomes 1 (the transmit/receive FIFO buffer contains no message (buffer empty)).
- (6) When the message matches the receive rule of the corresponding channel and the message has been successfully received, the routing processing to transfer the message to the specified buffer starts. When the DCE bit in the RSCFDn(CFD)GCFG register is set to 1 (DLC check is enabled), the DLC filter processing starts at this time.
- (7) The message is stored in the transmit/receive FIFO buffer set in receive mode when the message has passed through the DLC filter process if the CFE bit is set to 1 (transmit/receive FIFO buffers are used), and the CFDC[2:0] bits are set to 001b or more. The CFMC[7:0] bit value is incremented by 1 to be H'01. When the CFIM bit is set to 1 (an interrupt occurs each time a message has been received), the CFRXIF flag is set to 1 (a transmit/receive FIFO receive interrupt request is present).
The message is stored in the receive FIFO buffer if the RFE bit in the RSCFDn(CFD)RFCCx register is set to 1 (receive FIFO buffers are used), and the RFDC[2:0] bits in the RSCFDn(CFD)RFCCx register are set to 001b or more. The RFMC[7:0] bits in the RSCFDn(CFD)RFSTTx register are set to H'01 by being incremented by 1. When the RFIM bit in the RSCFDn(CFD)RFCCx register is set to 1 (an interrupt occurs each time a message has been received), the RFIF flag in the RSCFDn(CFD)RFSTTx register is set to 1 (a receive FIFO interrupt request is present).

28.11.2.3 FIFO Buffer Reading Procedure by DMA Transfer

In CANFD mode, the following FIFO buffers can be read by DMA transfer.

- All receive FIFO buffers x ($x = 0$ to 7)
- The first transmit/receive FIFO buffer k allocated to channel m ($k = 3 \times m$, $m = 0, 1$)

The DMA enable bit (RFDMAEx or CFDMAEm bit in the RSCFDnCFDCDTC register) can be set at any time. However, before setting the DMA enable bit to 1 (to enable DMA transfer requests), set the receive interrupt enable bit (RFIE bit in the RSCFDnCFDRFCCx register or CFRXIE bit in the RSCFDnCFDCFCCk register) of related FIFO buffers to 0 (to disable interrupts). When DMA transfer requests are enabled, do not write a value to the FIFO control register (RSCFDnCFDRFCCx register or RSCFDnCFDCFCCk register).

When an unread message is remaining in a DMA transfer-enabled FIFO buffer, a DMA transfer request trigger is generated. Specify the FIFO access register address for the transfer source address, and adjust the transfer size so that data can be read to the end of the payload storage area with a single trigger. The end of the payload storage area depends on the payload storage size specified by the RFPLS[2:0] bits in the RSCFDnCFDRFCCx register or the CFPLS[2:0] bits in the RSCFDnCFDCFCCk register.

After the end of the payload stored in the FIFO buffer has been read, the RFMC[7:0] value in the RSCFDnCFDRFSTSx register or the CFMC[7:0] value in the RSCFDnCFDCFSTS k register is automatically decremented. After that, if an unread message is remaining in the FIFO buffer, a trigger is generated again.

When the RFDMAEx or CFDMAEm bit is set to 0 (to disable DMA transfer requests) during DMA transfer, wait until the DMA transfer status (RFDMASTSx or CFDMASTS m bit in the RSCFDnCFDCDTS register) is cleared to 0 (DMA transfer disabled), and then start the next processing (enabling DMA transfer again etc.). When disabling DMA transfer, examine how to process a message remaining in the FIFO buffer and a newly arriving message. When the FIFO buffer is enabled, it continues to receive messages.

28.11.3 Transmission Procedure

28.11.3.1 Procedure for Transmission from Transmit Buffers

Figure 28.27 shows the procedure for transmission from transmit buffers.

Figure 28.28 shows a timing chart where messages are transmitted from two transmit buffers in the same channel and transmission has been successfully completed. **Figure 28.29** shows a timing chart where messages are transmitted from two transmit buffers in the same channel and transmit abort has been completed.

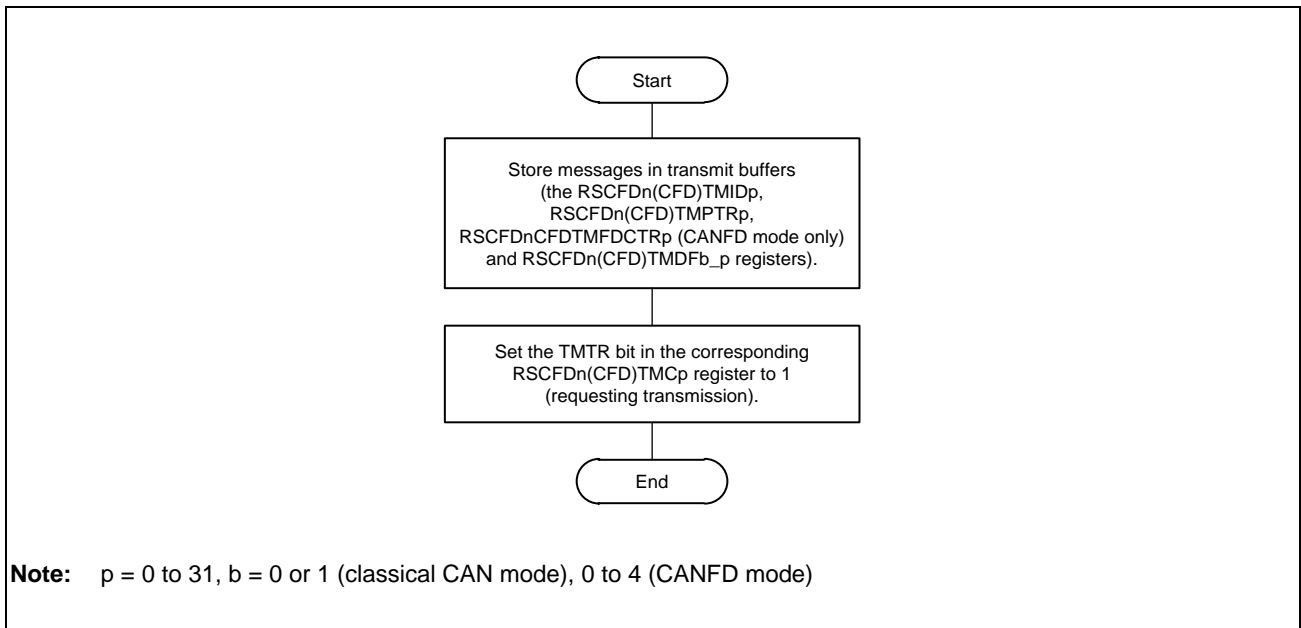

Figure 28.27 Procedure for Transmission from Transmit Buffers

In CANFD mode and transmit buffer merge mode, messages with a payload size of more than 20 bytes can be transmitted from transmit buffers $(16 \times m) + 0$ and transmit buffers $(16 \times m) + 3$. At this time, transmit buffers $(16 \times m) + 1$ to $(16 \times m) + 2$ and transmit buffers $(16 \times m) + 4$ to $(16 \times m) + 5$ are allocated as a payload storage area. Registers RSCFDnCFD(TM)IDp, RSCFDnCFD(TM)PTRp, and RSCFDnCFD(TM)FDCTRp corresponding to these buffers can be used as data field registers that can store 4-byte data bytes (payload) like the RSCFDnCFD(TM)DFb_p register. **Table 28.45** shows message storage registers when transmitting a message with a payload size of more than 20 bytes from transmit buffer 0.

Table 28.45 Message Storage Registers in Transmit Buffer Merge Mode (Example of Transmit Buffer 0)

Transmit Buffer	Offset from Base Address	Symbol	Register Function in Transmit Buffer Merge Mode
Transmit buffer 0	H'4000	RSCFDnCFDTMID0	Transmit buffer 0 ID data, transmit history data store enable bit, RTR bit, and IDE bit
	H'4004	RSCFDnCFDTMPTR0	Transmit buffer 0 label data and DLC data
	H'4008	RSCFDnCFDTMFDCTR0	Transmit buffer 0 ESI bit, BRS bit, and FDF bit
	H'400C to H'401C	RSCFDnCFDTMDF0_0 to RSCFDnCFDTMDF4_0	Transmit buffer 0 data bytes 0, 1, 2, and 3 to transmit buffer 0 data bytes 16, 17, 18, and 19
Transmit buffer 1	H'4020	RSCFDnCFDTMID1	Transmit buffer 0 data bytes 20, 21, 22, and 23
	H'4024	RSCFDnCFDTMPTR1	Transmit buffer 0 data bytes 24, 25, 26, and 27
	H'4028	RSCFDnCFDTMFDCTR1	Transmit buffer 0 data bytes 28, 29, 30, and 31
	H'402C to H'403C	RSCFDnCFDTMDF0_1 to RSCFDnCFDTMDF4_1	Transmit buffer 0 data bytes 32, 33, 34, and 35 to transmit buffer 0 data bytes 48, 49, 50, and 51
Transmit buffer 2	H'4040	RSCFDnCFDTMID2	Transmit buffer 0 data bytes 52, 53, 54, and 55
	H'4044	RSCFDnCFDTMPTR2	Transmit buffer 0 data bytes 56, 57, 58, and 59
	H'4048	RSCFDnCFDTMFDCTR2	Transmit buffer 0 data bytes 60, 61, 62, and 63
	H'404C to H'405C	RSCFDnCFDTMDF0_2 to RSCFDnCFDTMDF4_2	Not used

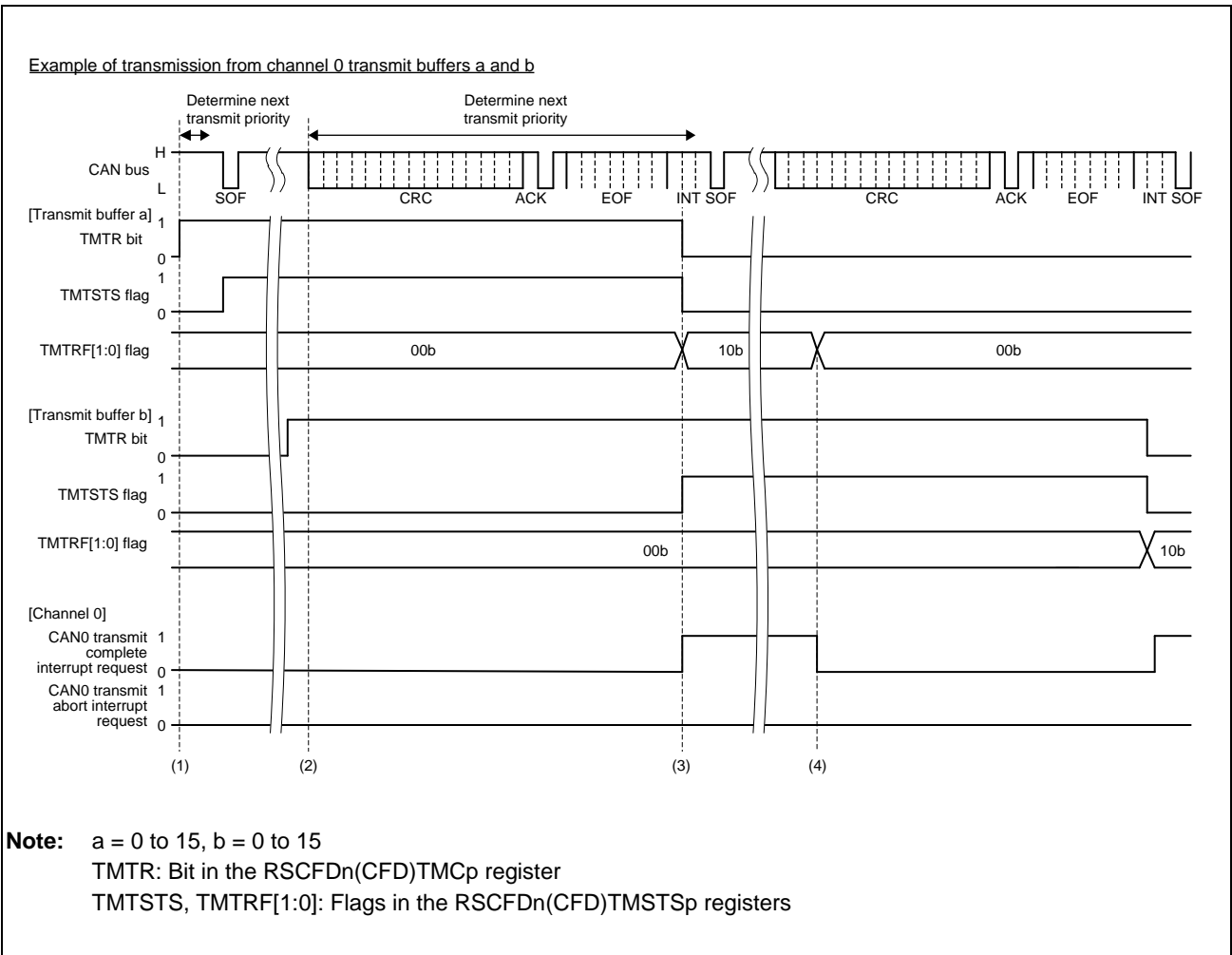

Figure 28.28 Transmit Buffer Transmission Timing Chart (Transmission Completed Successfully)

- (1) When the TMTR bit in the RSCFDn(CFD)TMCa register is set to 1 while the CAN bus is idle, the transmit priority determination processing starts to determine the highest-priority transmit buffer. If transmit buffer a is determined to be the highest-priority transmit buffer, the TMTSTS flag in the corresponding RSCFDn(CFD)TMSTSa register is set to 1 (transmission is in progress) and the CAN channel starts transmitting data.
- (2) When a transmit request from a buffer is present, the priority determination starts at the first bit of CRC field for the next transmission. The determination time may delay if the transmit priority determination processing is performed on another channel. However, the delay does not occur during transmission because the determination processing is completed by the third bit of the intermission.
- (3) When transmission completes successfully, the TMTRF[1:0] flag in the RSCFDn(CFD)TMSTSa register is set to 10b (transmission has been completed (without transmit abort request)) and the TMTSTS flag and the TMTR bit in the RSCFDn(CFD)TMCa register are cleared to 0. When the TMIEa bit in the RSCFDn(CFD)TMIEC0 register is 1 (transmit buffer interrupt is enabled), a CAN0 transmit complete interrupt request is generated. To clear the interrupt request, set the TMTRF[1:0] flag to 00b (transmission is in progress or no transmit request is present).
- (4) Before starting the next transmission, set the TMTRF[1:0] flag to 00b. Write the next message to the transmit buffer, and then set the TMTR bit to 1 (transmission is requested). The TMTR bit can be set to 1 only when the TMTRF[1:0] flag value is 00b.

If an arbitration-lost has occurred after transmission is started, the TMTSTS flag is cleared to 0. The transmit priority determination is reexecuted at the beginning of the CRC field to search the highest-priority transmit buffer. If an error has occurred during transmission or after arbitration loss, the priority determination processing is reexecuted during transmission of an error frame.

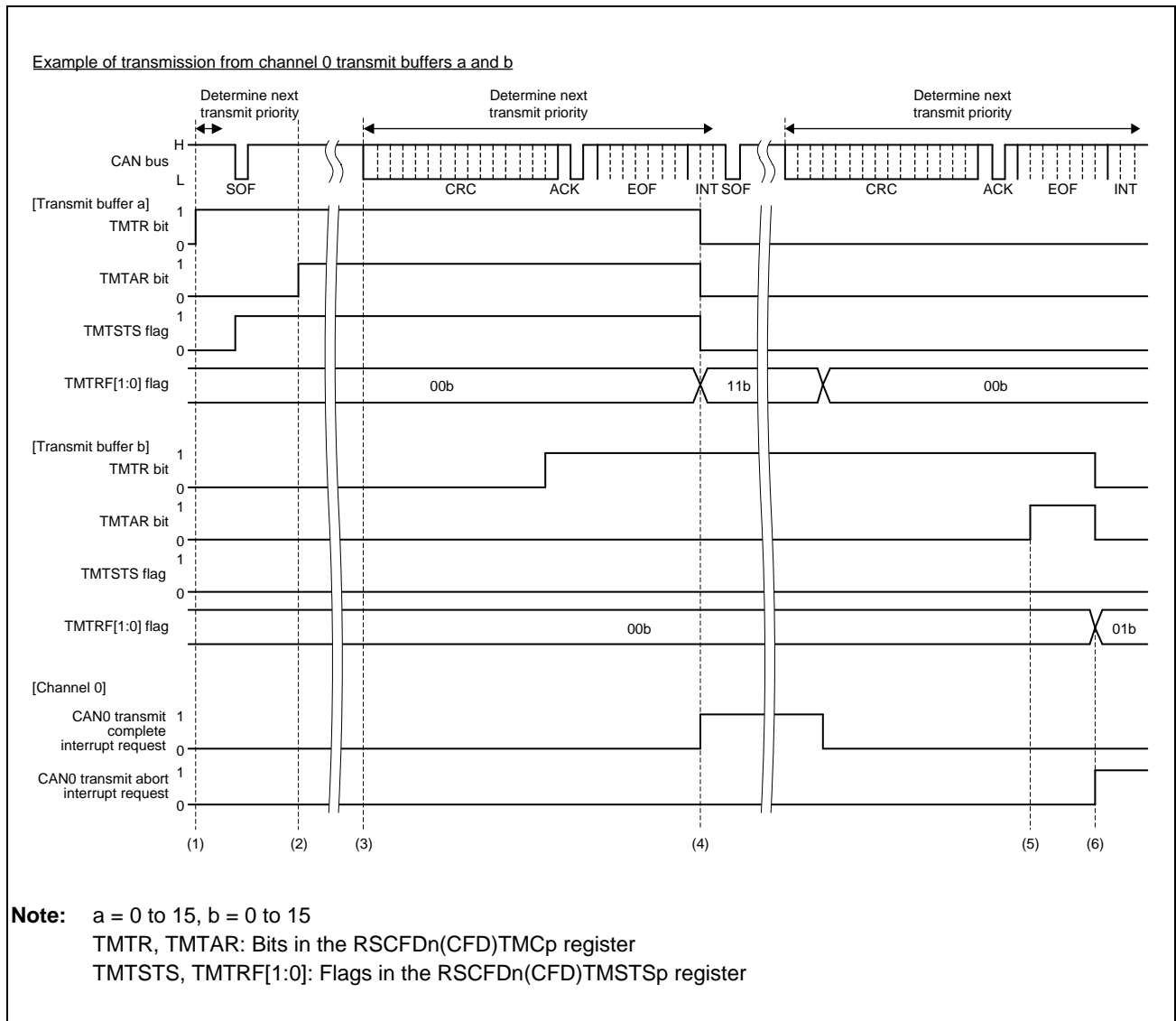

Figure 28.29 Transmit Buffer Transmission Timing Chart (Transmit Abort Completed)

- (1) When the TMTR bit in the RSCFDn(CFD)TMCa register is set to 1 while the CAN bus is idle, the transmit priority determination processing starts to determine the highest-priority transmit buffer. If transmit buffer a is determined to be the highest-priority transmit buffer, the TMTSTS flag in the corresponding RSCFDn(CFD)TMSTSa register is set to 1 (transmission is in progress) and the CAN channel starts transmitting data.
- (2) When it is determined that the transmit buffer is used for the next transmission or transmission is in progress, message transmission is not aborted unless an error or arbitration loss occurs even if the TMTAR bit is set to 1 (transmit abort is requested).
- (3) The priority determination starts at the first bit of the CRC field for the next transmission. In this timing chart, buffer b is not selected as the next transmit buffer. The determination time may delay if the transmit priority determination processing is performed on another channel. However, the delay does not occur during transmission because the determination processing is completed by the third bit of the intermission.
- (4) When transmission completes successfully, the TMTRF[1:0] flag in the RSCFDn(CFD)TMSTSa register is set to 11b (transmission has been completed (with transmit abort request)) and the TMTSTS flag and the TMTR bit in the RSCFDn(CFD)TMCa register are cleared to 0. When the TMIEa value in the RSCFDn(CFD)TMIEC0 register

is 1 (transmit buffer interrupt is enabled), a CAN0 transmit complete interrupt request is generated. To clear the interrupt request, set the TMTRF[1:0] flag to 00b (transmission is in progress or no transmit request is present).

- (5) While another CAN node is transmitting data on the CAN bus (TMTSTS flag = 0), if the TMTAR bit is set to 1 while the corresponding channel is determining transmit priority, the TMTR bit cannot be cleared to 0.
- (6) After the internal processing time has passed, the transmission is terminated and the TMTRF[1:0] flag is set to 01b. When the transmit buffer is not transmitting data and is not selected as the next transmit buffer and priority determination is not being made, an abort request is immediately accepted and the TMTRF[1:0] flag is set to 01b. At this time, the TMTR and TMTAR bits are cleared to 0. When transmit abort is completed with the TAIE bit in the RSCFDn(CFD)CmCTR register set to 1 (transmit abort interrupt is enabled), an interrupt request is generated. To clear the interrupt request, set the TMTRF[1:0] flag to 00b.

If an arbitration loss has occurred after the CAN channel started transmission, the TMTSTS bit is cleared to 0. The transmit priority determination is reexecuted at the beginning of the CRC field to find the highest-priority transmit buffer. If an error has occurred during transmission or after arbitration loss, the priority determination processing is reexecuted during transmission of an error frame.

28.11.3.2 Procedure for Transmission from Transmit/Receive FIFO Buffers

Figure 28.30 shows the procedure for transmission from transmit/receive FIFO buffers.

Figure 28.31 shows a timing chart where messages are transmitted from two transmit/receive FIFO buffers in the same channel and transmission has been successfully completed. Figure 28.32 shows a timing chart where messages are transmitted from two transmit/receive FIFO buffers in the same channel and transmit abort has been completed.

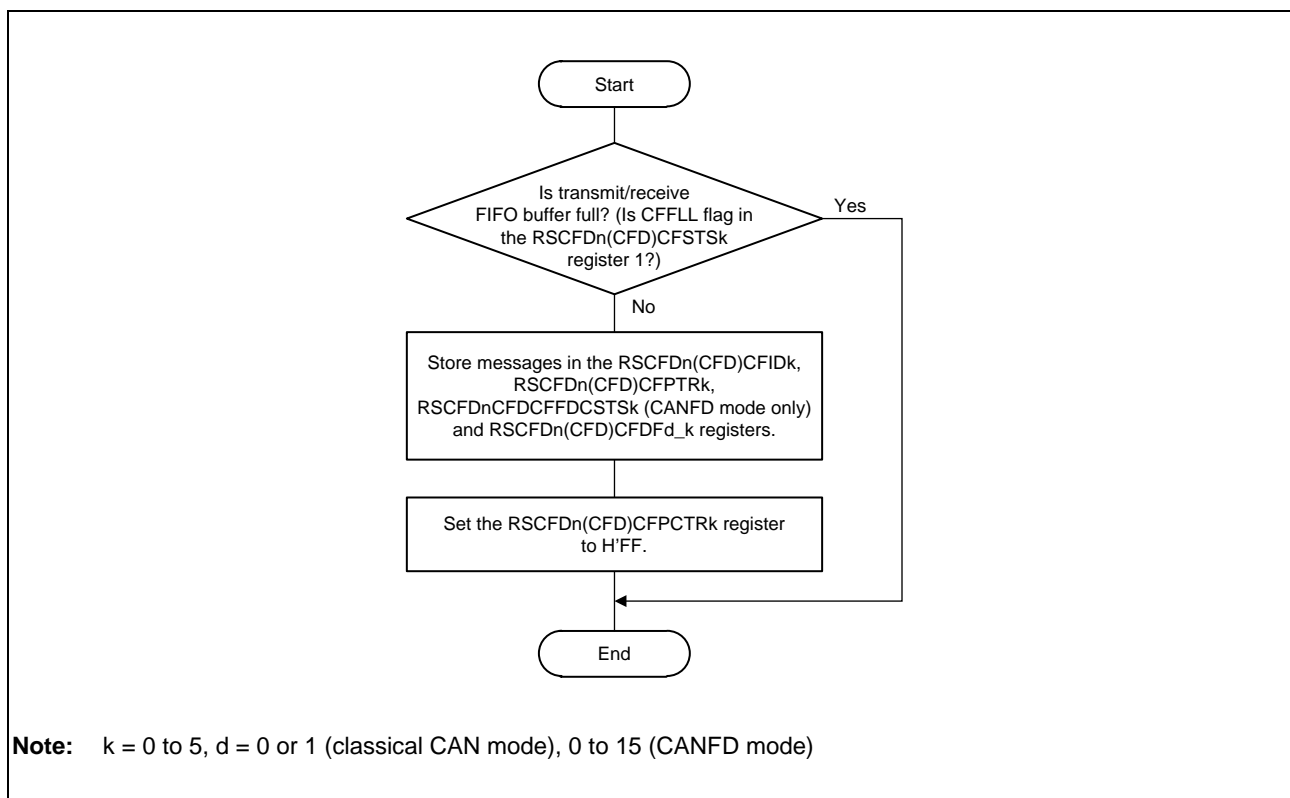

Figure 28.30 Procedure for Transmission from Transmit/Receive FIFO Buffers

When storing a message, do not write a value to the RSCFDnCFDCFDf_d_k register corresponding to the area exceeding the payload storage size specified by the CFPLS[2:0] bits in the RSCFDnCFDCFCCK register.

Table 28.46 Payload Storage Area of Transmit/Receive FIFO Buffer

Set CFPLS[2:0] Value	Payload Storage Size	Corresponding Data Field Registers
000b	8 bytes	RSCFDnCFDCFDf0_k to RSCFDnCFDCFDf1_k
001b	12 bytes	RSCFDnCFDCFDf0_k to RSCFDnCFDCFDf2_k
010b	16 bytes	RSCFDnCFDCFDf0_k to RSCFDnCFDCFDf3_k
011b	20 bytes	RSCFDnCFDCFDf0_k to RSCFDnCFDCFDf4_k
100b	24 bytes	RSCFDnCFDCFDf0_k to RSCFDnCFDCFDf5_k
101b	32 bytes	RSCFDnCFDCFDf0_k to RSCFDnCFDCFDf7_k
110b	48 bytes	RSCFDnCFDCFDf0_k to RSCFDnCFDCFDf11_k
111b	64 bytes	RSCFDnCFDCFDf0_k to RSCFDnCFDCFDf15_k

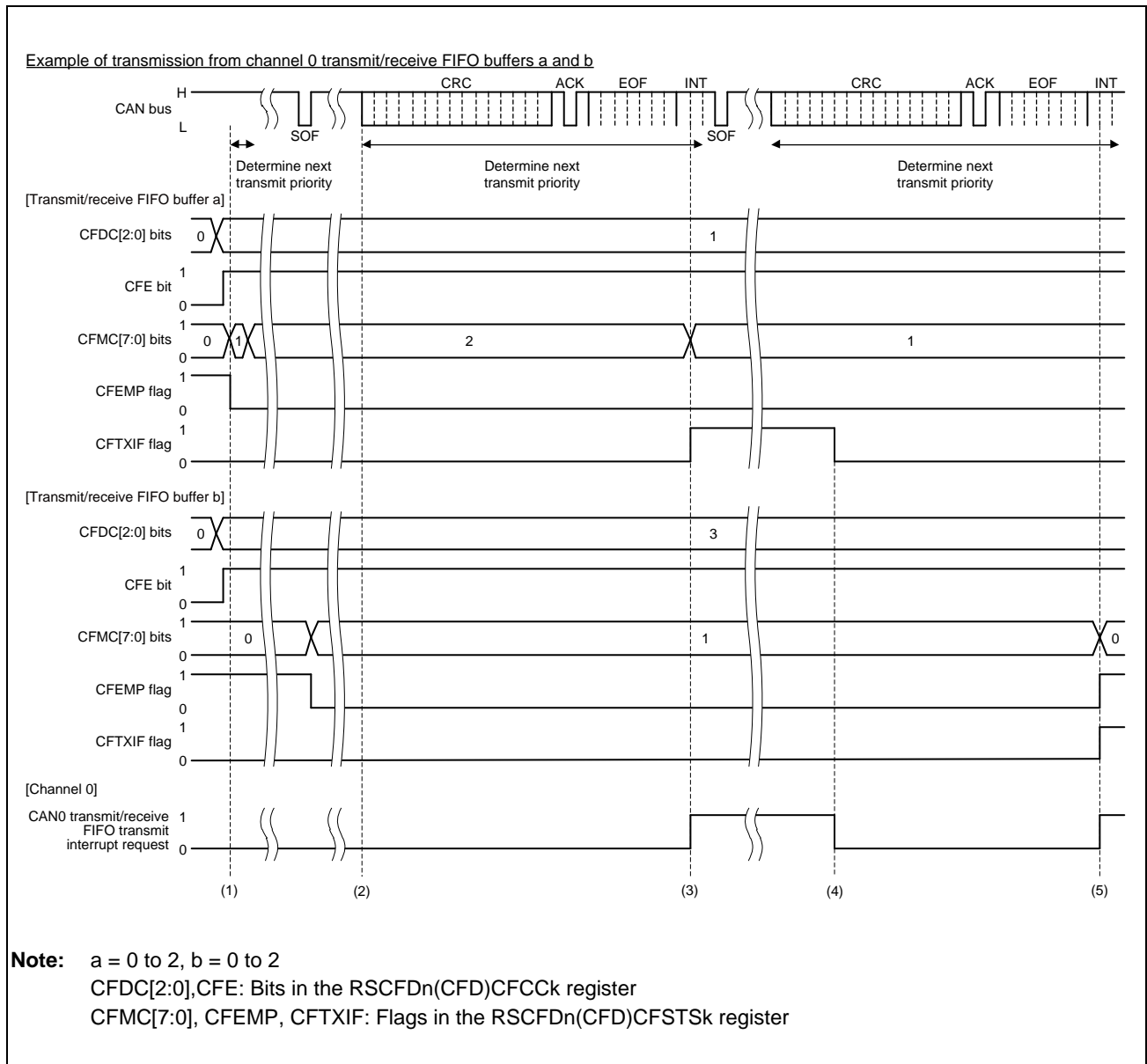

Figure 28.31 Transmit/Receive FIFO Buffer Transmission Timing Chart (Transmission Completed Successfully)

- (1) While the CAN bus is idle, when the CFE bit in the RSCFDn(CFD)CFCCa register is 1 (transmit/receive FIFO buffers are used) and the CFDC[2:0] value in the RSCFDn(CFD)CFCCa register is 001b (4 messages) or more and the CFMC[7:0] value in the RSCFDn(CFD)CFSTSa register is H'01 or more, the priority determination processing starts to determine the highest-priority transmit message. When the highest-priority transmit message has been determined, transmission of the message starts. In this figure, the message is transmitted from transmit/receive FIFO buffer a of channel 0.
- (2) When a transmit request from a buffer is present, the priority determination starts at the first bit of the CRC field for the next transmission. The determination time may delay if the transmit priority determination processing is performed on another channel. However, the delay does not occur during transmission because the determination processing is completed by the third bit of the intermission.
- (3) When transmission completes successfully, the CFMC[7:0] value in the RSCFDn(CFD)CFSTSa register is decremented. Setting the CFIM bit in the RSCFDn(CFD)CFCCa register to 1 (a FIFO transmit interrupt request is

generated each time a message has been transmitted) sets the CFTXIF flag in the RSCFDn(CFD)CFSTSk register to 1 (a transmit/receive FIFO transmit interrupt request is present).

- (4) The program can clear the CFTXIF flag.
- (5) Message transmission from transmit/receive FIFO buffer b of channel 0 has been completed and the CFMC[7:0] value in the RSCFDn(CFD)CFSTSk register is decremented. The CFMC[7:0] bits are cleared to H'00 and therefore the CFEMP flag in the RSCFDn(CFD)CFSTSk register is set to 1 (the transmit/receive FIFO buffer contains no message (buffer empty)).

Transmission is continued until the CFEMP flag is set to 1. It is possible to continuously store transmit messages in FIFO buffers until the CFLL flag in the RSCFDn(CFD)CFSTSa and RSCFDn(CFD)CFSTSk register is set to 1 (the transmit/ receive FIFO buffer is full).

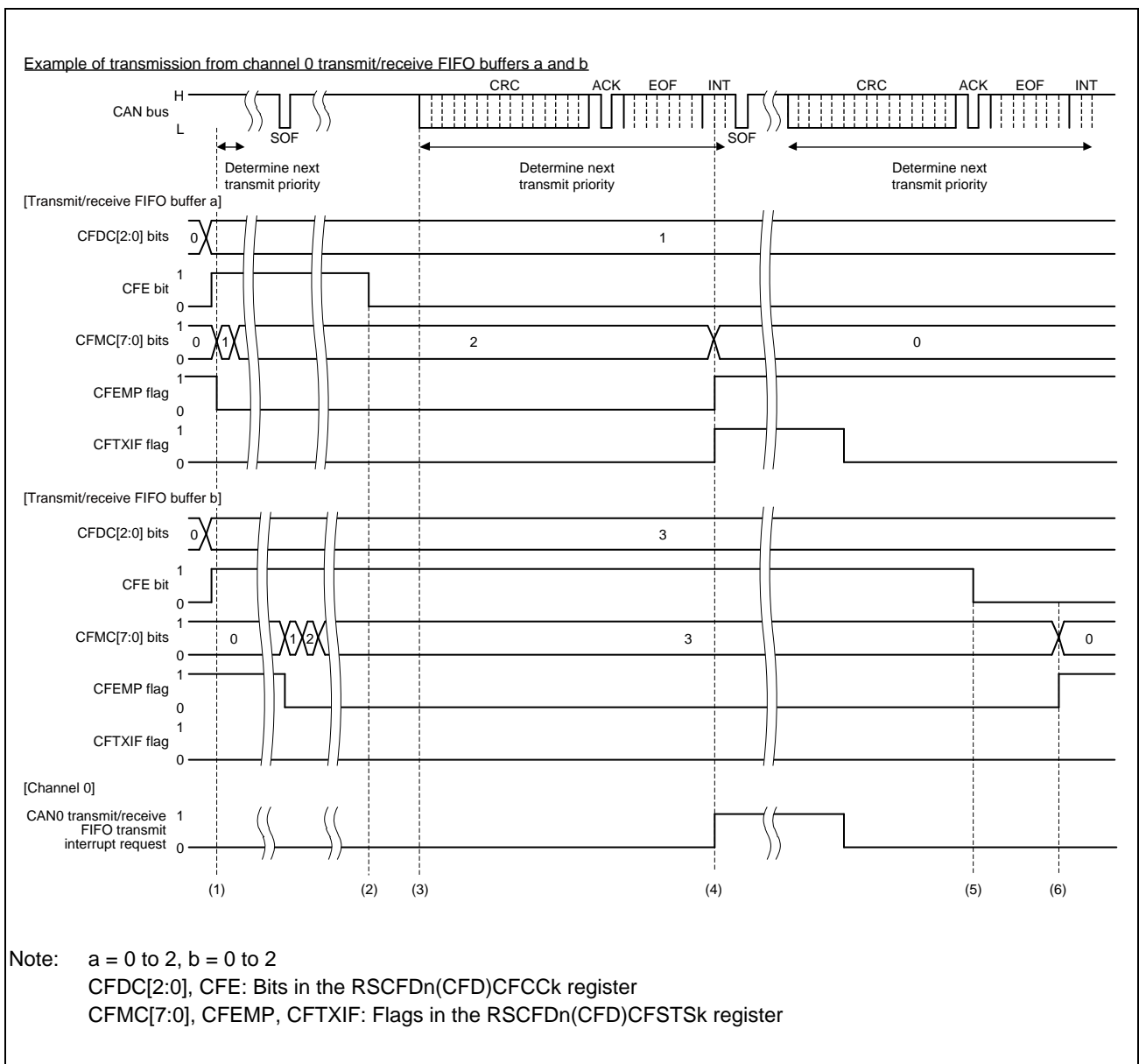

Figure 28.32 Transmit/Receive FIFO Buffer Transmission Timing Chart (Transmit Abort Completed)

- (1) While the CAN bus is idle, when the CFE bit in the RSCFDn(CFD)CFCCa register is 1 (transmit/receive FIFO buffers are used) and the CFDC[2:0] value in the RSCFDn(CFD)CFCCa register is 001b (4 messages) or more and the CFMC[7:0] value in the RSCFDn(CFD)CFSTSa register is H'01 or more, the priority determination processing starts to determine the highest-priority transmit message. When the highest-priority transmit message has been determined, transmission of the message starts. In this figure, the message is transmitted from transmit/receive FIFO buffer a of channel 0.
- (2) When transmission is in progress or it is determined that the transmit/receive FIFO buffer is used for the next transmission, message transmission is not aborted unless an error or arbitration loss occurs even if the CFE bit is set to 0 (no transmit/receive FIFO buffer is used).
- (3) When a transmit request from a buffer is present, the priority determination starts at the first bit of the CRC field for the next transmission. In this figure, transmit/receive FIFO buffer b is not selected as a buffer for the next transmission. The determination time may delay if the transmit priority determination processing is performed on another channel. However, the delay does not occur during transmission because the determination processing is completed by the third bit of the intermission.
- (4) When transmit completes successfully, the CFMC[7:0] value is cleared to H'00. Setting the CFIM bit to 1 (a FIFO transmit interrupt request is generated each time a message has been transmitted) sets the CFTXIF flag in the RSCFDn(CFD)CFSTSa register to 1 (a transmit/receive FIFO transmit interrupt request is present). The program can clear the CFTXIF flag.
- (5) If another CAN node on the CAN bus is transmitting data (not from transmit/receive FIFO buffer b), transmit/receive FIFO buffers cannot be disabled immediately even if the CFE bit in the RSCFDn(CFD)CFCCb register is cleared to 0 (no transmit/receive FIFO buffer is used) during transmit priority determination. (The CFEMP flag in the RSCFDn(CFD)CFSTSB register is not set to 1 (the transmit/receive FIFO buffer contains no message (buffer empty)) immediately.)
- (6) After the internal processing time has passed, transmit/receive FIFO buffers are disabled and the CFMC[7:0] bits in the RSCFDn(CFD)CFSTSB register are cleared to H'00 and the CFEMP flag is set to 1. When the transmit/receive FIFO buffer is not transmitting data and is not selected as the next transmit buffer and priority determination is not in progress, the transmit/receive FIFO buffer is immediately disabled. (The CFMC[7:0] bits are cleared to H'00 and the CFEMP flag is set to 1.)

28.11.3.3 Procedure for Transmission from the Transmit Queue

Figure 28.33 shows the procedure for transmission from the transmit queue.

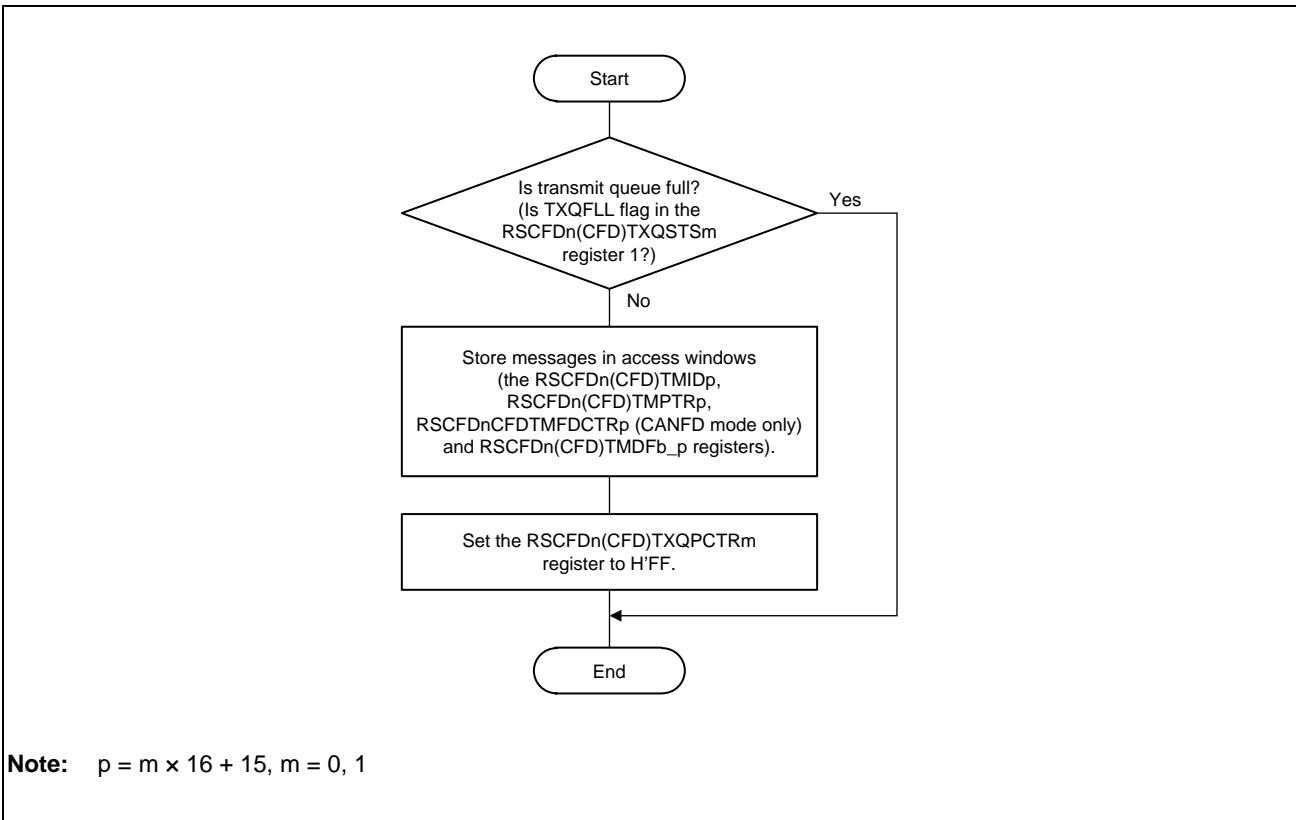

Figure 28.33 Procedure for Transmission from the Transmit Queue

28.11.3.4 Transmit History Buffer Reading Procedure

Transmit history data can be read from the RSCFDn(CFD)THLACCm register. The next data can be accessed by writing H'FF to the corresponding RSCFDn(CFD)THLPCTRm register (m = 0, 1) after reading a set of data. **Figure 28.34** shows the transmit history buffer reading procedure.

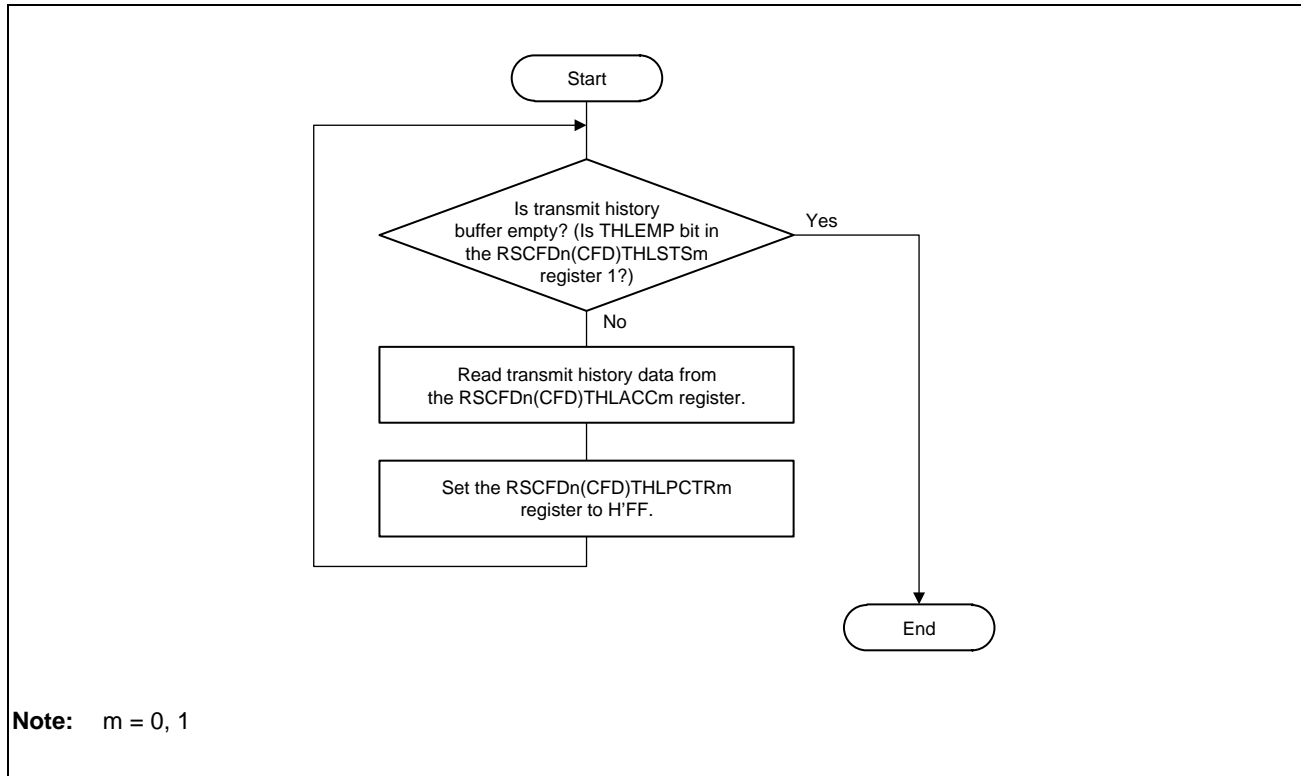

Figure 28.34 Transmit History Buffer Reading Procedure

28.11.4 Test Settings

28.11.4.1 Self-Test Mode Setting Procedure

Self-test mode allows communication test on a channel basis by enabling a CAN node to receive its own transmitted messages.

Figure 28.35 shows the self-test mode setting procedure.

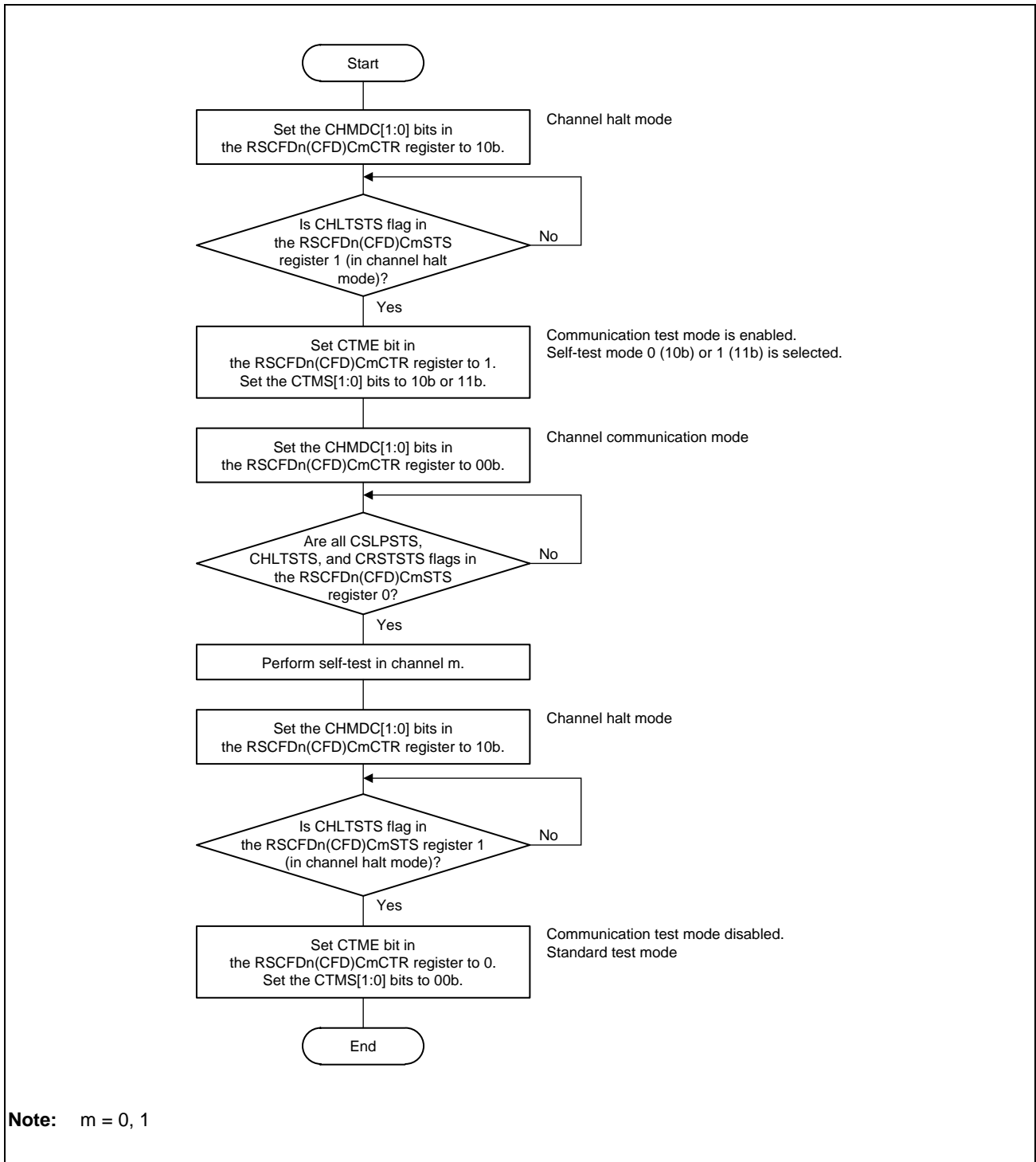

Figure 28.35 Self-Test Mode Setting Procedure

28.11.4.2 Procedure for Releasing the Protection

Since the global test function in **Table 28.47** is protected, write the protection release data 1 and release data 2 in succession to the LOCK[15:0] bits in the RSCFDn(CFD)GLOCKK register, then set the target test bit to 1.

Table 28.47 Protection Release Data for Test Function

Test Function	Protection Release Data 1	Protection Release Data 2	Target Bit
RAM test	H'7575	H'8A8A	RTME bit in the RSCFDn(CFD)GTSTCTR register

If an incorrect value is written to the LOCK[15:0] bits, restart from writing the protection release data 1. **Figure 28.36** shows the procedure for releasing the protection.

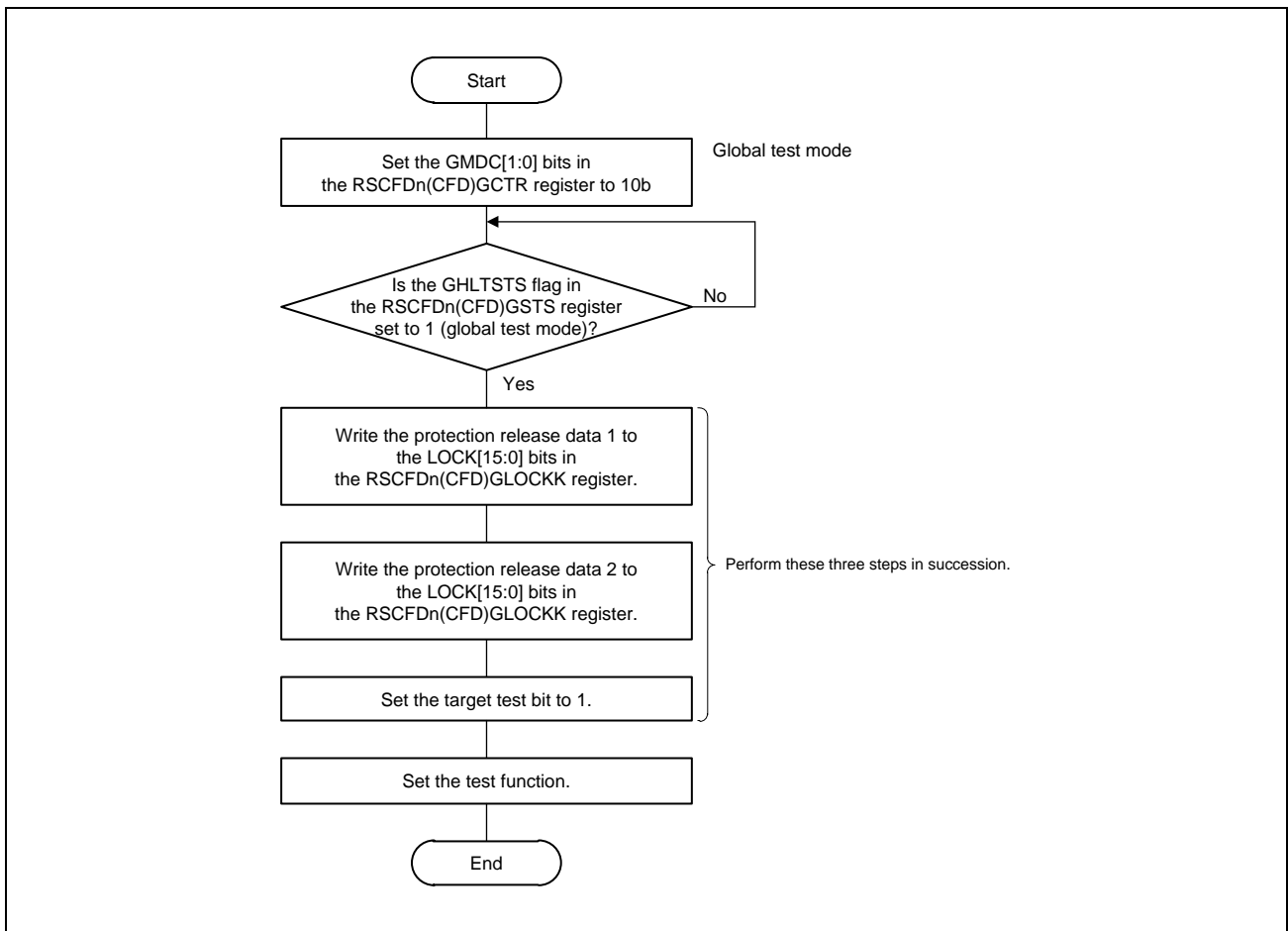

Figure 28.36 Protection Release Procedure

28.11.4.3 RAM Test Setting Procedure

RAM tests include CAN RAM read/write test. The read/write test verifies that data written to the RAM is read correctly. Before closing the RAM test, write H'0000 0000 to all pages of the CAN RAM.

Figure 28.37 shows the RAM test setting procedure.

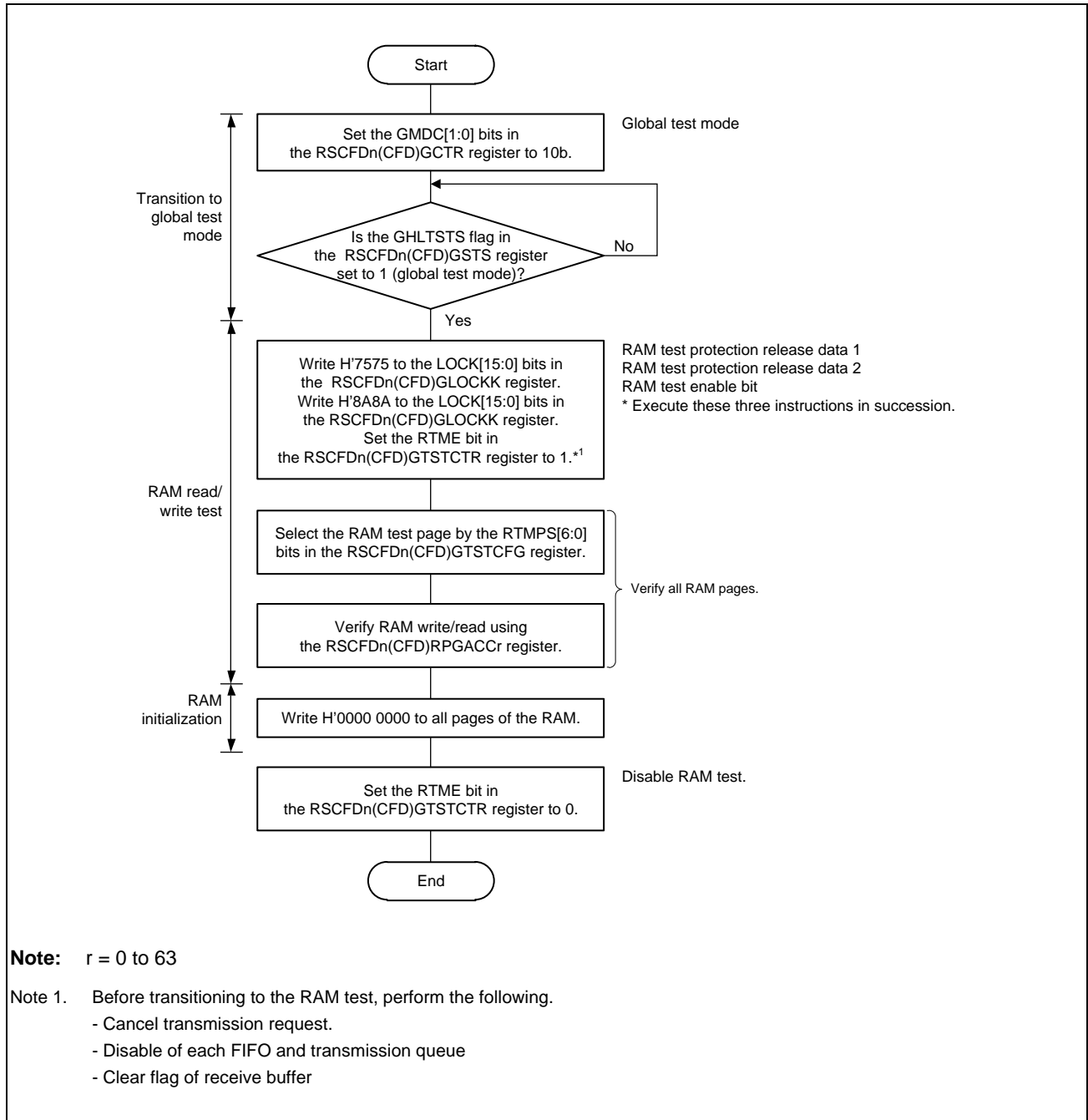

Figure 28.37 RAM Test Setting Procedure

28.11.4.4 Inter-Channel Communication Test Setting Procedure

Communication testing can be performed by transmitting and receiving data between different channels.

Figure 28.38 shows the inter-channel communication test setting procedure.

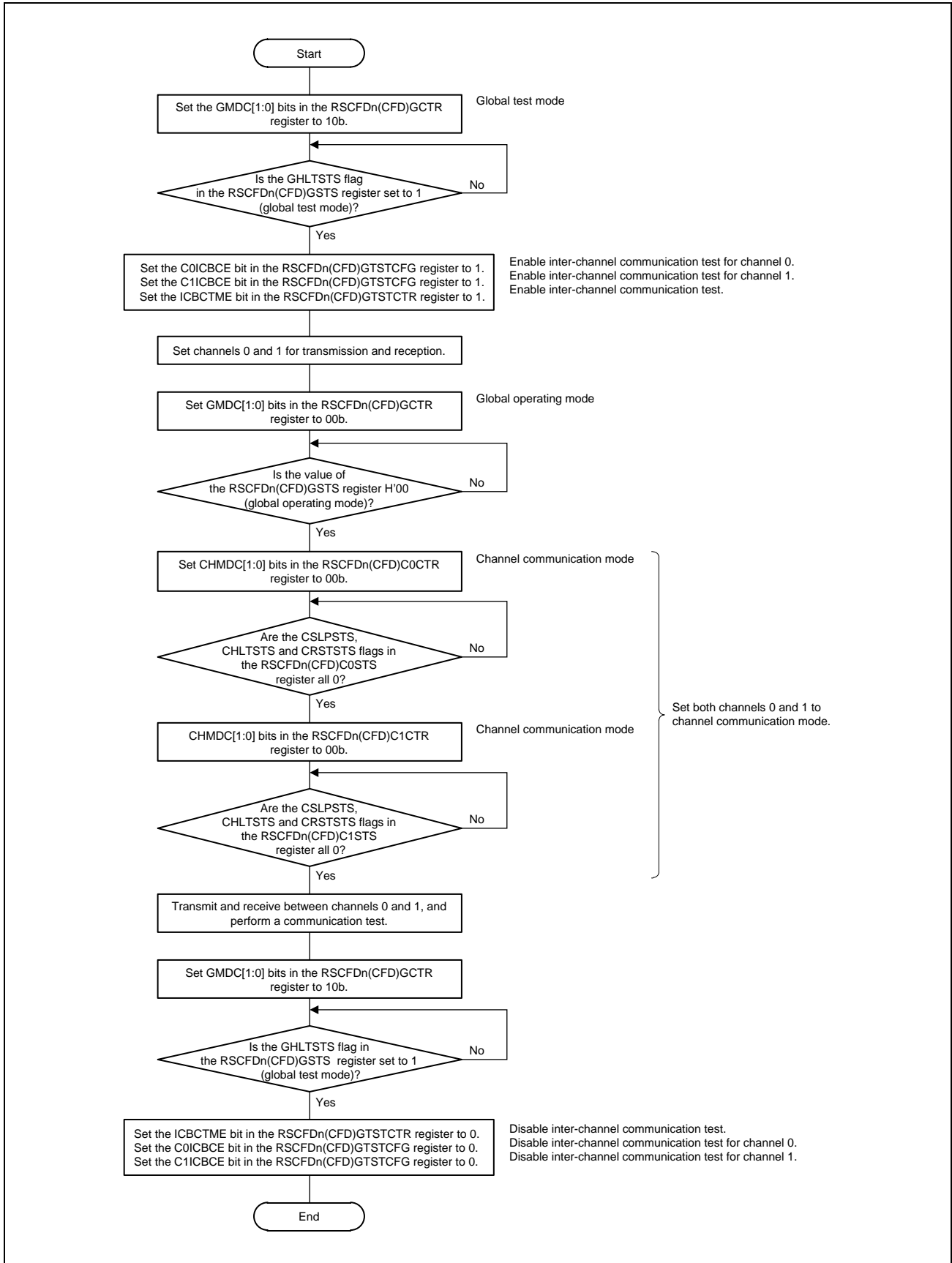

Figure 28.38 Inter-Channel Communication Test Setting Procedure (Example of Communication Test between Channel 0 and Channel 1)

28.12 Notes on the RS-CANFD Module

- When changing interface mode without resetting the RS-CANFD, write the value after reset to all registers and bits that are not allocated to the register map after change and then modify the RSCFDnCFDGRMCFG register.
- When changing a global mode, check the GSLPSTS, GHLTSTS, and GRSTSTS flags in the RSCFDn(CFD)GSTS register for transitions. When changing a channel mode, check the CSLPSTS, CHLTSTS, and CRSTSTS flags in the RSCFDn(CFD)CmSTS register (m = 0, 1) for transitions.
- When only classical CAN frames are used in CANFD mode, set the RSCFDnCFDCmDCFG register to the value equal to the set RSCFDnCFDCmNCFG register value.
- The acceptance filter processing checks receive rules sequentially in ascending order from the minimum rule number. If the same ID, IDE bit, or RTR bit value is set for multiple receive rules, the minimum number of receive rule is used for the acceptance filter processing. If the message does not pass through the subsequent DLC filter processing, the data processing is terminated without returning to the acceptance filter processing and the message is not stored in the buffer.
- When linking transmit buffers to transmit/receive FIFO buffers or allocating transmit buffers to transmit queues, set the control register (RSCFDn(CFD)TMCp) of the corresponding transmit buffer to H'00. The status register (RSCFDn(CFD)TMSTSp) of the corresponding transmit buffer should not be used. Flags in other status registers (registers RSCFDn(CFD)TMTRSTS0 to RSCFDn(CFD)TMTRSTS2, RSCFDn(CFD)TMTARSTS0 to RSCFDn(CFD)TMTARSTS2, RSCFDn(CFD)TMTASTS0 to RSCFDn(CFD)TMTASTS2), which correspond to transmit buffers linked to transmit/receive FIFO buffers or allocated to transmit queues remain unchanged. Set the enable bit in the corresponding interrupt enable register (registers RSCFDn(CFD)TMIEC0 to RSCFDn(CFD)TMIEC2) to 0 (transmit buffer interrupt is disabled).
- When using transmit buffer merge mode (in CANFD mode), write H'00 to the control register (RSCFDn(CFD)TMCp) of the transmit buffer corresponding to the transmit buffer allocated as a payload storage area. Set the enable bit of corresponding interrupt enable registers (RSCFDn(CFD)TMIEC0 to RSCFDn(CFD)TMIEC2) to 0 (to disable interrupts).
- Transmit buffers that are linked to transmit/receive FIFO buffers must not be allocated to transmit queues. Do not allocate a transmit buffer allocated as a payload storage area in transmit buffer merge mode (in CANFD mode) to the transmit queue either.
- Only a single transmit/receive FIFO buffer can be linked to a transmit buffer. Do not link two or more transmit/receive FIFO buffers to transmit buffers of the same number.
- When the CANm bit time clock is selected as a timestamp counter clock source, the timestamp counter stops when the corresponding channel has transitioned to channel reset mode or channel halt mode.
- In case of an attempt to store a new received message when the receive FIFO buffer and the transmit/receive FIFO buffer are full, the new message is discarded. If you wish to store a new transmit message in the transmit/receive FIFO buffer or the transmit queue, check that the transmit/receive FIFO buffer or the transmit queue is not full.
- In the case of registers that access the RAM, the value after reset shown in **Section 28.3, Registers (Classical CAN Mode)** and **Section 28.4, Registers (CANFD Mode)** indicate the values cleared by initialization of the CAN RAM. Values before clear are undefined. The following registers apply.
 - Receive rule (RSCFDn(CFD)GAFLIDj, RSCFDn(CFD)GAFLMj, RSCFDn(CFD)GAFLP0_j, RSCFDn(CFD)GAFLP1_j registers)
 - Receive buffers (RSCFDn(CFD)RMIDq, RSCFDn(CFD)RMPTRq, RSCFDnCFDRMFDSTSq, RSCFDn(CFD)RMDfb_q registers)

- Receive FIFO buffer access registers (RSCFDn(CFD)RFIDx, RSCFDn(CFD)RFPTRx, RSCFDnCFDRFFDSTSx, and RSCFDn(CFD)RFDFd_x registers)
- Transmit/receive FIFO buffer access registers (RSCFDn(CFD)CFIDk, RSCFDn(CFD)CFPTRk, RSCFDnCFDCFFDCSTSk, and RSCFDn(CFD)CFDFd_k registers)
- Transmit buffers (RSCFDn(CFD)TMIDp, RSCFDn(CFD)TMPTRp, RSCFDnCFDTMFDCTRp, and RSCFDn(CFD)TMDfb_p registers)
- Transmit history access register (RSCFDn(CFD)THLACCm registers)
- RAM test page access register (RSCFDn(CFD)RPGACCr registers)
- The values of unused receive buffers (RSCFDn(CFD)RMIDq, RSCFDn(CFD)RMPTRq, RSCFDnCFDRMFDSTSq, and RSCFDn(CFD)RMDfb_q registers), receive FIFO buffer access registers (RSCFDn(CFD)RFIDx, RSCFDn(CFD)RFPTRx, RSCFDnCFDRFFDSTSx, and RSCFDn(CFD)RFDFd_x registers) and transmit/receive FIFO buffer access registers (RSCFDn(CFD)CFIDk, RSCFDn(CFD)CFPTRk, RSCFDnCFDCFFDCSTSk, and RSCFDn(CFD)CFDFd_k registers) are undefined when the RS-CANFD module transitions to global operation mode or global test mode after exiting from global reset mode.

30. Gigabit Ethernet Interface

Gigabit Ethernet Interface includes Ethernet controller (E-MAC) that conforms to the definition of the MAC (Media Access Control) layer for Ethernet in the IEEE 802.3 standard. When connected with a physical-layer LSI chip (PHY-LSI) that complies with the standard, the E-MAC is able to transmit and receive Ethernet (IEEE 802.3) frames. The E-MAC has a single MAC layer interface.

Internal TCP/IP Offload Engine (TOE) calculates Checksum by hardware and has functions filtering Ethernet Frames and automatically responding specific frames. Dedicated Direct memory access controller (DMAC) for transferring transmitted Ethernet frames to and received Ethernet frames from respective storage areas in the URAM at high speed.

30.1 Features

30.1.1 Specification

- 2 channels
- Supports transfer at 1000 Mbps and 100 Mbps, 10 Mbps
- Supports filtering of Ethernet frames
- Supports interface conforming to IEEE802.3 PHY RGMII (Reduced Gigabit Media Independent Interface)
- Supports interface conforming to IEEE802.3 PHYMII (Media Independent Interface)

Table 30.1 lists the features of the Gigabit Ethernet Interface block.

Table 30.1 Specifications (Functions) (1/2)

IP Name	1. Function
E-MAC	(1) Transmission and reception of Ethernet (IEEE 802.3) frames (2) Supports transfer at 10, 100 and 1000 Mbps in Full-duplex Mode, 10, 100 Mbps in Half-duplex Mode (3) Flow control conforming with the IEEE 802.3x standard (4) Supports MII (Media Independent Interface) and RGMII (Reduced Gigabit Media Independent Interface) (5) Transmission/Reception Low Power Idle Code
TOE	(1) Calculation of Checksum for following part of frames <ul style="list-style-type: none"> – IPv4 Header – IPv4 TCP/UDP/ICMP – IPv6 TCP/UDP/ICMP (2) Filtering of Ethernet Frames The Possible Configuration of Filter Condition are followings. <ul style="list-style-type: none"> – Ethernet Type – IP Protocol No. – UDP destination port No. – Destination MAC address (Unicast) – Destination MAC address (Broadcast) – Destination MAC address (Multicast) – ARP Request of Local Station – Neighbor Solicitation of Local Station – Except IPv6 Next Header (Analyzable) (3) Automatically Responding to ARP Request and Neighbor Solicitation

Table 30.1 Specifications (Functions) (2/2)

IP Name	1. Function
DMAC	(1) Supports AXI for DMA (128bit data width) (2) Supports APB for register access (32bit data width) (3) Direct Memory Access between URAM and TOE/E-MAC by Descriptor Method (4) Supported Maximum Frame Size are followings. – Transmission Frame is 1.5 KByte – Reception Frame is 8 Kbyte

30.1.2 Block Diagram

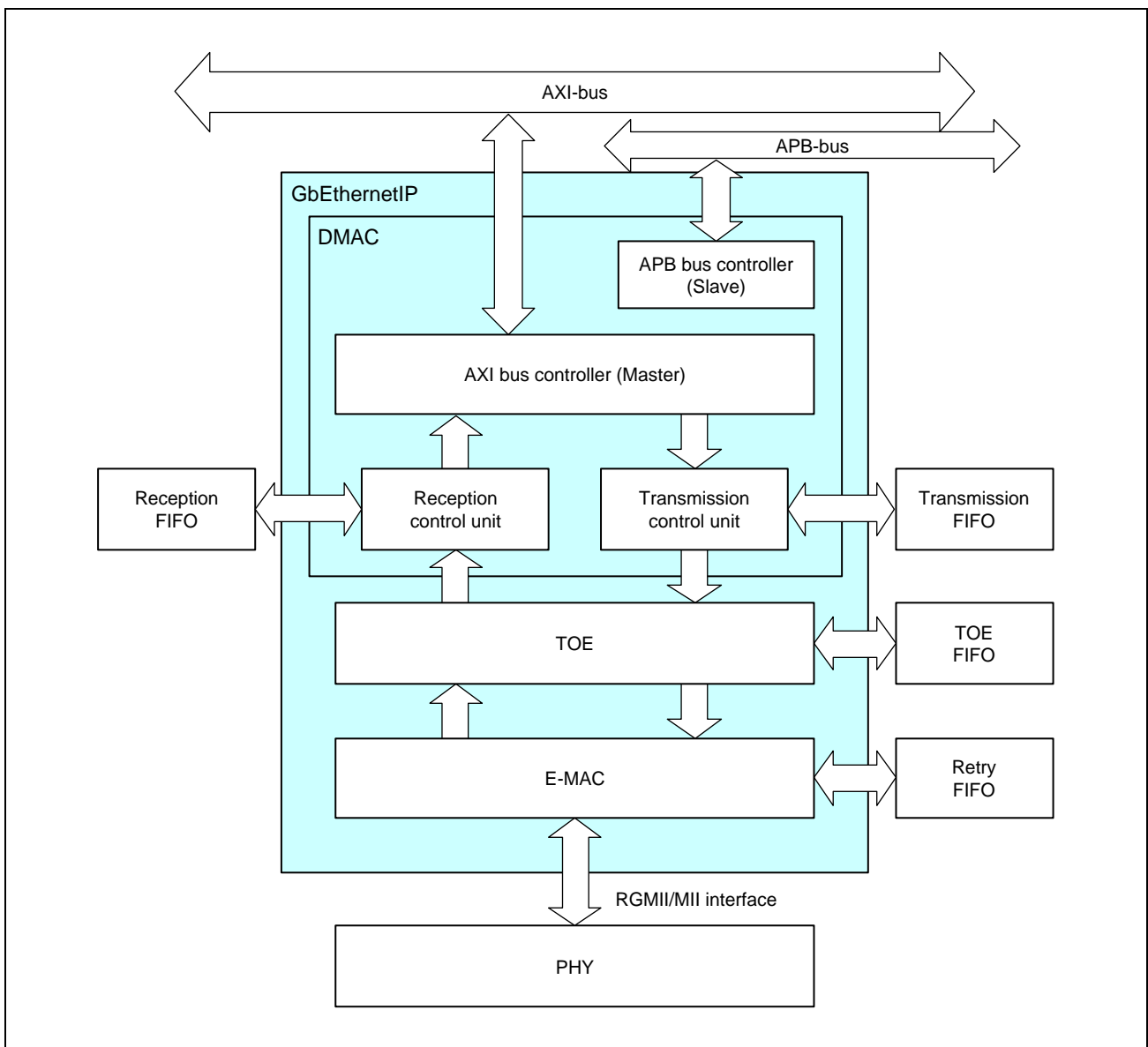

Figure 30.1 Block Diagram of Gigabit Ethernet Interface

30.2 External Signal Pins

Table 30.2 shows external signal pins for Gigabit Ethernet Interface.

Table 30.2 External Pin Interface

Name	I/O		Description	Active Level	Initial Value	
	RGMI	MII			RGMI	MII
ET0_TXC/TX_CLK	Output	Input	Ch0 transmit clock signal	—	0b	—
ET0_TX_CTL/TX_EN	Output	Output	Ch0 Transmit control/enable signal	H	0b	0b
ET0_TXD[3-0]	Output	Output	Ch0 Transmit data signal	—	0b	0b
ET0_TX_ERR	Unused	Output	Ch0 Transmit error signal	H	—	0b
ET0_TX_COL	Unused	Input	Ch0 Transmit collision signal	H	—	—
ET0_TX_CRS	Unused	Input	Ch0 Transmit carrier sense signal	H	—	—
ET0_RXC/RX_CLK	Input	Input	Ch0 Receive clock signal	—	—	—
ET0_RX_CTL/RX_DV	Input	Input	Ch0 Receive data Control/valid signal	H	—	—
ET0_RXD[3-0]	Input	Input	Ch0 Receive data signal	—	—	—
ET0_RX_ERR	Unused	Input	Ch0 Receive error signal	H	—	—
ET0_MDC	Output	Output	Ch0 Management information transfer clock signal	—	0b	0b
ET0_MDIO	I/O	I/O	Ch0 Management information transmit/receive data	—	—	—
ET0_LINKSTA	Input	Input	Ch0 PHY Link status signal	H	—	—
ET1_TXC/TX_CLK	Input	Input	Ch1 transmit clock signal	—	—	—
ET1_TX_CTL/TX_EN	Output	Output	Ch1 Transmit control/enable signal	H	0b	0b
ET1_TXD[3-0]	Output	Output	Ch1 Transmit data signal	—	0b	0b
ET1_TX_ERR	Unused	Output	Ch1 Transmit error signal	H	—	0b
ET1_TX_COL	Unused	Input	Ch1 Transmit collision signal	H	—	—
ET1_TX_CRS	Unused	Input	Ch1 Transmit carrier sense signal	H	—	—
ET1_RXC/RX_CLK	Input	Input	Ch1 Receive clock signal	—	—	—
ET1_RX_CTL/RX_DV	Input	Input	Ch1 Receive data Control/valid signal	H	—	—
ET1_RXD[3-0]	Input	Input	Ch1 Receive data signal	—	—	—
ET1_RX_ERR	Unused	Input	Ch1 Receive error signal	H	—	—
ET1_MDC	Output	Output	Ch1 Management information transfer clock signal	—	0b	0b
ET1_MDIO	I/O	I/O	Ch1 Management information transmit/receive data	—	—	—
ET1_LINKSTA	Input	Input	Ch1 PHY Link status signal	H	—	—

30.3 Register Configuration

30.3.1 Register Base Address

The base addresses of each channel are listed in the following table.

Table 30.3 Register Base Address

Register Name	Base Address Name	Base Address
ETH0	<ETH0_AX45MP_base>	H'0_11C2_0000
ETH1	<ETH1_AX45MP_base>	H'0_11C3_0000

30.3.2 IO Mode Registers

Refer to **Section 41, General Purpose Input Output Port (GPIO)** for Gigabit Ethernet Interface IO mode configuration.

30.3.3 DMAC Registers

Table 30.4 Configuration of DMAC-related Registers (From H'000 to H'4FF) (1/2)

Register Name	Abbreviation	R/W	Initial Value	Offset Address	Access Size
DMAC mode register	CCC	R/W	H'0000 0000	H'000	32
Descriptor base address table register	DBAT	R/W	H'0000 0000	H'004	32
Descriptor base address load request register	DLR	R/W	H'003F FFFF	H'008	32
DMAC status register	CSR	R	H'0000 0001	H'00C	32
Current descriptor address register q (q = 0,4)	CDARq	R	H'0000 0000	H'010 + q × 4	32
Error status register	ESR	R	H'0000 0000	H'088	32
Receive configuration register	RCR	R/W	H'6000 0000	H'090	32
Reception Truncation Configuration register	RTC	R/W	H'7FFC 7FFC	H'0B4	32
Transmit configuration register	TGC	R/W	H'0022 2200	H'300	32
Transmit configuration control register	TCCR	R/W	H'0000 0000	H'304	32
Transmit status register	TSR	R	H'0000 0000	H'308	32
MAC status FIFO Access register	MFA	R	H'0000 0000	H'30C	32
MAC status FIFO Access 2 register	MFA2	R	H'0000 0000	H'340	32
Descriptor interrupt control register	DIC	R/W	H'0000 0000	H'350	32
Descriptor interrupt status register	DIS	R/W	H'0000 0000	H'354	32
Error interrupt control register	EIC	R/W	H'0000 0000	H'358	32
Error interrupt status register	EIS	R/W	H'0000 0000	H'35C	32
Receive interrupt control register 0	RIC0	R/W	H'0000 0000	H'360	32
Receive interrupt status register 0	RIS0	R/W	H'0000 0000	H'364	32
Receive interrupt control register 1	RIC1	R/W	H'0000 0000	H'368	32
Receive interrupt status register 1	RIS1	R/W	H'0000 0000	H'36C	32
Receive interrupt control register 2	RIC2	R/W	H'0000 0000	H'370	32
Receive interrupt status register 2	RIS2	R/W	H'0000 0000	H'374	32
Transmit interrupt control register	TIC	R/W	H'0000 0000	H'378	32

Table 30.4 Configuration of DMAC-related Registers (From H'000 to H'4FF) (2/2)

Register Name	Abbreviation	R/W	Initial Value	Offset Address	Access Size
Transmit interrupt status register	TIS	R/W	H'0000 0000	H'37C	32
Interrupt summary status register	ISS	R	H'0000 0000	H'380	32
Common Interrupt Enable register	CIE	R/W	H'0000 0000	H'384	32
Receive Interrupt Control register 3	RIC3	R/W	H'0000 0000	H'388	32
Receive Interrupt Status register 3	RIS3	R/W	H'0000 0000	H'38C	32
Descriptor Interrupt Enable register	DIE	R/W	H'0000 0000	H'450	32
Descriptor Interrupt Disable register	DID	R/W	H'0000 0000	H'454	32
Error Interrupt Enable register	EIE	R/W	H'0000 0000	H'458	32
Error Interrupt Disable register	EID	R/W	H'0000 0000	H'45C	32
Receive Interrupt Enable register 0	RIE0	R/W	H'0000 0000	H'460	32
Receive Interrupt Disable register 0	RID0	R/W	H'0000 0000	H'464	32
Receive Interrupt Enable register 1	RIE1	R/W	H'0000 0000	H'468	32
Receive Interrupt Disable register 1	RID1	R/W	H'0000 0000	H'46C	32
Receive Interrupt Enable register 2	RIE2	R/W	H'0000 0000	H'470	32
Receive Interrupt Disable register 2	RID2	R/W	H'0000 0000	H'474	32
Transmit Interrupt Enable register	TIE	R/W	H'0000 0000	H'478	32
Transmit Interrupt Disable register	TID	R/W	H'0000 0000	H'47C	32
Receive Interrupt Enable register 3	RIE3	R/W	H'0000 0000	H'488	32
Receive Interrupt Disable register 3	RID3	R/W	H'0000 0000	H'48C	32

30.3.4 E-MAC Registers

Table 30.5 Configuration of E-MAC-related Registers (From H'500 to H'7FF) (1/2)

Register Name	Abbreviation	R/W	Initial Value	Offset Address	Access Size
E-MAC operating mode register	CXR20	R/W	H'0000 0000	H'500	32
Maximum receive frame length register	CXR2A	R/W	H'0000 0000	H'508	32
Interrupt status register	CXR21	R/W	H'0000 000X	H'510	32
Enables/disables interrupts register	CXR22	R/W	H'0000 0000	H'518	32
PHY register access register	CXR23	R/W	H'0000 000X	H'520	32
Link status register	CXR2B	R	H'0000 000X	H'528	32
Polarity set register	CXR2C	R/W	H'0000 0000	H'52C	32
In-Band Status set register	CXR31	R/W	H'0000 0000	H'530	32
In-Band Status indicate register	CXR32	R	H'0000 000X	H'534	32
Mode indicate register	CXR33	R	H'0000 0000	H'538	32
PHY interface select register	CXR35	R/W	H'FFFF 0000	H'540	32
PHY interface indicate register	CXR36	R	H'0000 0000	H'544	32
PAUSE frame register 1	CXR71	R/W	H'0000 0000	H'554	32
PAUSE frame register 2	CXR72	R/W	H'0000 0000	H'558	32
PAUSE frame register 3	CXR8A	R/W	H'0000 0000	H'55C	32
PAUSE frame register 4	CXR80	R/W	H'0000 0000	H'560	32
PAUSE frame register 5	CXR81	R/W	H'0000 0000	H'564	32
PAUSE frame register 6	CXR82	R	H'0000 0000	H'568	32

Table 30.5 Configuration of E-MAC-related Registers (From H'500 to H'7FF) (2/2)

Register Name	Abbreviation	R/W	Initial Value	Offset Address	Access Size
E-MAC operating mode 2 register	CXR2D	R/W	H'0000 0000	H'5B0	32
Software LINK status register	CXR2G	R/W	H'0000 0000	H'5BC	32
Mac Address register 1	CXR24	R/W	H'0000 0000	H'5C0	32
Mac Address register 2	CXR25	R/W	H'0000 0000	H'5C8	32
TINT1 counter register	CXR40	R/W	H'0000 0000	H'700	32
TINT2 counter register	CXR41	R/W	H'0000 0000	H'708	32
TINT3 counter register	CXR42	R/W	H'0000 0000	H'710	32
RINT1 counter register	CXR50	R/W	H'0000 0000	H'740	32
RINT2 counter register	CXR51	R/W	H'0000 0000	H'748	32
RINT3 counter register	CXR52	R/W	H'0000 0000	H'750	32
RINT4 counter register	CXR53	R/W	H'0000 0000	H'758	32
RINT5 counter register	CXR54	R/W	H'0000 0000	H'760	32
RINT6 counter register	CXR55	R/W	H'0000 0000	H'768	32
RINT7 counter register	CXR56	R/W	H'0000 0000	H'770	32
RINT8 counter register	CXR57	R/W	H'0000 0000	H'778	32
MDIO status register	MDIOSTS	R	H'0000 0000	H'780	32
MDIO command register	MDIOCMD	R/W	H'0000 0000	H'784	32
MDIO address register	MDIOADR	R/W	H'0000 0000	H'788	32
MDIO data register	MDIODAT	R/W	H'0000 0000	H'78C	32
MDIO mode register	MDIOMOD	R/W	H'8000 00FF	H'790	32
Low Power Mode register 1	LPTXMOD1	R/W	H'0000 0000	H'7B0	32
Low Power Mode register 2	LPTXMOD2	R/W	H'0000 0000	H'7B4	32
RGMIILow Power parameter register 1	LPTXGTH1	R/W	H'0000 0000	H'7C0	32
RGMIILow Power parameter register 2	LPTXGTH2	R/W	H'0000 0000	H'7C4	32
RGMIILow Power parameter register 3	LPTXGTH3	R/W	H'0000 0000	H'7C8	32
RGMIILow Power parameter register 4	LPTXGTH4	R/W	H'0000 0000	H'7CC	32
MII Low Power parameter register 1	LPTXMTH1	R/W	H'0000 0000	H'7D0	32
MII Low Power parameter register 2	LPTXMTH2	R/W	H'0000 0000	H'7D4	32
MII Low Power parameter register 3	LPTXMTH3	R/W	H'0000 0000	H'7D8	32
MII Low Power parameter register 4	LPTXMTH4	R/W	H'0000 0000	H'7DC	32

30.3.5 TOE Registers

Table 30.6 Configuration of TOE-related Registers (From H'800 to H'9FF) (1/2)

Register Name	Abbreviation	R/W	Initial Value	Offset Address	Access Size
Checksum operating mode register	CSR0	R/W	H'0000 0000	H'800	32
Tx Frame Checksum Enable register	CSR1	R/W	H'0000 0000	H'804	32
Rx Frame Checksum Enable register	CSR2	R/W	H'0000 0000	H'808	32
Tx Extended Header Number register	CSR3	R/W	H'0000 0008	H'80C	32
Rx Extended Header Number register	CSR4	R/W	H'0000 0008	H'810	32
Unsupported Tx Frame Counter register	CSR20	R/W	H'0000 0000	H'820	32
Unsupported Rx Frame Counter register	CSR30	R/W	H'0000 0000	H'824	32
Rx IPv4 Header checksum Error Counter register	CSR31	R/W	H'0000 0000	H'828	32
Rx TCP/UDP/ICMP checksum Error Counter register	CSR32	R/W	H'0000 0000	H'82C	32
Filter Operation/Auto Response Enable register	CSFR00	R/W	H'1020 0000	H'840	32
Local IPv4 address register	CSFR01	R/W	H'0000 0000	H'844	32
Local IPv6 address register i (i=0 to 3)	CSFR02_i	R/W	H'0000 0000	H'848 + 4 × i	32
Upper Local MAC address register	CSFR03_U	R/W	H'0000 0000	H'858	32
Lower Local MAC address register	CSFR03_L	R/W	H'0000 0000	H'85C	32
IPv6 no_next_header Protocol Number register	CSFR04	R/W	H'0000 003B	H'860	32
Ethernet Type Condition register i (i=0 to 3)	CSFR10_i	R/W	H'0000 0000	H'870 + 4 × i	32
Ethernet Type Condition Enable register	CSFR10	R/W	H'0000 0000	H'880	32
Protocol Condition register i (i=0 to 3)	CSFR11_i	R/W	H'0000 0000	H'884 + 4 × i	32
Protocol Condition Enable register	CSFR11	R/W	H'0000 0000	H'894	32
UDP Por Condition register i (i=0 to 11)	CSFR12_i	R/W	H'0000 0000	H'898 + 4 × i	32
UDP Port Condition Enable register	CSFR12	R/W	H'0000 0000	H'8C8	32
Upper MAC DA unicast address Condition register	CSFR13_U	R/W	H'0000 0000	H'8CC	32
Lower MAC DA unicast address Condition register	CSFR13_L	R/W	H'0000 0000	H'8D0	32
Upper MAC DA broadcast address Condition register	CSFR14_U	R/W	H'0000 FFFF	H'8D4	32
Lower MAC DA broadcast address Condition register	CSFR14_L	R/W	H'FFFF FFFF	H'8D8	32
Upper MAC DA multicast address Condition register i (i=0 to 19)	CSFR15_U_i	R/W	H'0000 0100	H'8DC + 8 × i	32
Lower MAC DA multicast address Condition register i (i=0 to 19)	CSFR15_L_i	R/W	H'5E00 0000	H'8E0 + 8 × i	32
MAC DA Condition Enable register	CSFR15	R/W	H'0000 0000	H'97C	32
IPv6 analysis Protocol Condition register 0	CSFR16_0	R/W	H'2911 0600	H'980	32
IPv6 analysis Protocol Condition register 1	CSFR16_1	R/W	H'3A33 2C2B	H'984	32
IPv6 analysis Protocol Condition register 2	CSFR16_2	R/W	H'0000 003C	H'988	32
IPv6 analysis Protocol Condition Enable register	CSFR16	R/W	H'0000 01FF	H'98C	32
Wake Up Interrupt Status register	CSFR20	R/W	H'0000 0000	H'9A0	32
Wake Up Interrupt Mask register	CSFR21	R/W	H'101F FFFF	H'9A4	32

Table 30.6 Configuration of TOE-related Registers (From H'800 to H'9FF) (2/2)

Register Name	Abbreviation	R/W	Initial Value	Offset Address	Access Size
Auto Response Configuration register1	CSFR30	R/W	H'0001 7B35	H'9B0	32
Auto Response Configuration register2	CSFR31	R/W	H'0000 0000	H'9B4	32
ARPREQ/Neighbor Solicitations Receive Interrupt Status register	CSFR40	R/W	H'0000 0000	H'9C0	32
ARPREQ/Neighbor Solicitations Receive Interrupt Mask register	CSFR41	R/W	H'0000 0007	H'9C4	32
Rx ARPREQ/Neighbor Solicitation Upper MAC SA register	CSFR42_U	R	H'0000 0000	H'9C8	32
Rx ARPREQ/Neighbor Solicitation Lower MAC SA register	CSFR42_L	R	H'0000 0000	H'9CC	32
Rx ARPREQ/Neighbor Solicitation IP SA register i (i=0 to 3)	CSFR43_i	R	H'0000 0000	H'9D0 + 4 × i	32

30.4 Register Descriptions

30.4.1 DMAC Registers

30.4.1.1 DMAC Mode Register (CCC)

The CCC register specifies the operating mode of the DMAC.

Bit	31	30	29	28	27	26	25	24	23	22	21	20	19	18	17	16
	—	—	—	—	—	—	FCE	—	—	—	—	BOC	—	ERCS	—	—
Initial Value	0	0	0	0	0	0	0	0	0	0	0	0	0	0	0	0
R/W	R	R	R	R	R	R	R/W	R	R	R	R	R/W	R	R/W	R	R
Bit	15	14	13	12	11	10	9	8	7	6	5	4	3	2	1	0
	—	—	—	—	—	—	RDFD	DTSR	—	—	—	—	—	—	OPC[1:0]	
Initial Value	0	0	0	0	0	0	0	0	0	0	0	0	0	0	0	0
R/W	R	R	R	R	R	R	R/W	R/W	R	R	R	R	R	R	R/W	R/W

Bit	Bit Name	Initial Value	R/W	Description
31 to 26	—	All 0	R	Reserved When read, the initial value is read. When writing, be sure to write the initial value. Operation is not guaranteed if a value other than the initial value is written.
25	FCE	0b	R/W	Flow Control Enable 0b Flow control disabled 1b Flow control enabled This bit enables the flow control support of E-MAC. When flow control is enabled, the E-MAC gets informed about the Reception FIFO level (Reception FIFO fill level reached RCR.RFCL).
24 to 21	—	All 0	R	Reserved When read, the initial value is read. When writing, be sure to write the initial value. Operation is not guaranteed if a value other than the initial value is written.
20	BOC	0b	R/W	Byte Order Configuration 0b First Ethernet byte in URAM [7:0] This bit defines the byte ordering of frame data in URAM in relation to the byte order in the Ethernet frame. The CPU can only write 0b to this bit.*1
19	—	0b	R	Reserved Whenever it is read, 0 is read. The written value will be ignored.
18	ERCS	0b	R/W	Enable Reference 250MHz Clock Stop function 0b Disable reference 250 MHz clock(clk_miitx_gtx_refclk) stop function. 1b Enable reference 250 MHz clock(clk_miitx_gtx_refclk) stop function. This bit enables the stop function of reference clock of Ethernet. When this bit is '1', Gigabit Ethernet Interface asserts Output Signal "refclk_stop_en" during it does not need reference clock. <i>Note:</i> If PHY does not support stopping TXC of RGMII Interface, set "0" to this bit. Because TXC is generated from clk_miitx_gtx_refclk. [Changing condition] This bit is set to 0b when RESET mode is entered.
17 to 10	—	All 0	R	Reserved Whenever it is read, 0 is read. The written value will be ignored.

Bit	Bit Name	Initial Value	R/W	Description
9	RDFD	0b	R/W	<p>Reception Descriptor Fetch Disable</p> <p>0b Reception Descriptor Fetch Enable</p> <p>1b Reception Descriptor Fetch Disable</p> <p>This register is used to stop the fetch of reception descriptor. By fetch stops, the state of Reception Descriptor Controller of DMAC will stop at IDLE.</p> <p>CSR.RDFDM indicates the current fetch status of reception descriptor.</p> <p>The CPU should not change any configuration or mode until CSR.RDFDM is updated once the Reception Descriptor Fetch Disable request is given.</p> <p>The CPU should not cancel the Reception Descriptor Fetch Disable request (set this bit to 0b) before CSR.RDFDM is read as 1b.</p>
8	DTSR	0b	R/W	<p>Data Transfer Suspend Request</p> <p>0b Normal operation</p> <p>1b Request suspension of data transfer</p> <p>This bit requests to suspend further Gigabit Ethernet Interface accesses to URAM. A currently on-going access is completed. CSR.DTS indicates the current suspend status.</p> <p>The CPU should not change any configuration or mode until CSR.DTS is updated once data transfer suspend request is given.</p> <p>The CPU should not cancel the data transfer suspend request (set this bit to 0b) before CSR.DTS is read as 1b.</p>
7 to 2	—	All 0	R	<p>Reserved</p> <p>Whenever it is read, 0 is read. The written value will be ignored.</p>
1 to 0	OPC	00b	R/W	<p>Operation Command</p> <p>00b Enter RESET mode</p> <p>01b Enter CONFIG mode</p> <p>10b Enter OPERATION mode</p> <p>11b Reserved</p> <p>These bits define the operating mode DMAC should enter. Refer to Section 4.1 for details about the operating modes.</p> <p>The CPU can write to these bits in any operating mode. [Changing condition]</p> <p>These bits are set to 00b when RESET mode is entered.</p>

Note 1. Following illustrates a received Ethernet frame and the part of the frame stored in URAM.

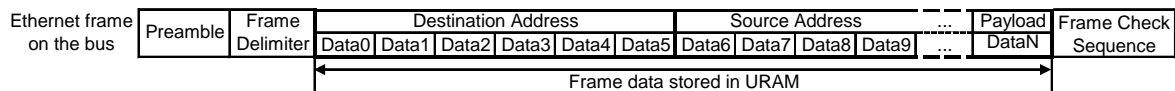

When CCC.BOC is 0b, an Ethernet frame is represented in URAM as:

Bit	31	30	29	28	27	26	25	24	23	22	21	20	19	18	17	16	15	14	13	12	11	10	9	8	7	6	5	4	3	2	1	0
DPTR+0	Data3			Data2			Data1			Data0																						
DPTR+4	Data7			Data6			Data5			Data4																						
DPTR+8	Data11			Data10			Data9			Data8																						

30.4.1.2 Descriptor Base Address Table Register (DBAT)

The DBAT register specifies the base address of the descriptor table in the URAM.

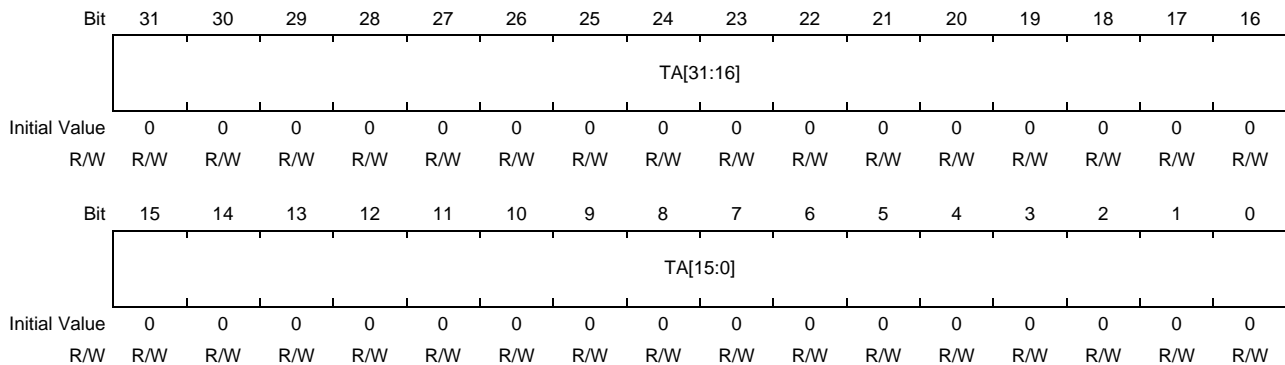

Bit	Bit Name	Initial Value	R/W	Description
31 to 0	TA[31:0]	H'0000_000	R/W	<p>Table Address</p> <p>Address of descriptor base address table in URAM</p> <p>These bits define the address of the first entry of the descriptor base address table. Refer to Section 4.2.3 about function and structure of the descriptor base address table.</p> <p>The CPU can only write to these bits if CSR.OPS is CONFIG and OPERATION.</p> <p>The CPU should only write values which are a multiple of 4 to these bits.</p>

30.4.1.3 Descriptor Base Address Load Request Register (DLR)

The DLR register is used to issue a request to load the values from the count descriptor address register q (CDARq) for each queue to the descriptor base address table register (DBAT).

Bit	31	30	29	28	27	26	25	24	23	22	21	20	19	18	17	16
	—	—	—	—	—	—	—	—	—	—	—	—	—	—	—	—
Initial Value	0	0	0	0	0	0	0	0	0	0	1	1	1	1	1	1
R/W	R	R	R	R	R	R	R	R	R	R	R	R	R	R	R	R
Bit	15	14	13	12	11	10	9	8	7	6	5	4	3	2	1	0
	—	—	—	—	—	—	—	—	—	—	—	LBA4	—	—	—	LBA0
Initial Value	1	1	1	1	1	1	1	1	1	1	1	1	1	1	1	1
R/W	R	R	R	R	R	R	R	R	R	R	R	R/W	R	R	R	R/W

Bit	Bit Name	Initial Value	R/W	Description
31 to 22	—	All 0	R	Reserved Whenever it is read, 0 is read. The written value will be ignored.
21 to 5	—	All 1	R	Reserved Whenever it is read, all bits 1 are read. The written value will be ignored.
4	LBA4	1b	R/W	Load Base Address 4(Rx0) 0b No pending load request 1b Pending load request This bit requests to set the current descriptor address of queue q (CDARq.CDA) to an entry of the descriptor base address table (DBAT.TA + 8*4). By setting this bit to 1b CPU requests a load of the current descriptor address of queue q. If there is an on-going transfer for queue q, the load is processed after the whole frame has been transferred. Note: In case of a transmission queue, the load function is not influencing the transmit start request (TCCR.TSRQ); so, fetching continues at base address. To prevent this behavior, it is recommended to request the load of transmission queues only when TCCR.TSRQ is 0b. The CPU can only write to this bit if CSR.OPS is OPERATION. The CPU can only write 1b to this bit. [Changing condition] This bit is set to 1b when leaving OPERATION mode. This bit is set to 0b when there is no on-going transfer (related to old chain) for queue q. Note for verification: In Rx, if the entirety or the final part of a frame is stored into a FEMPTY_ND descriptor, then there is no actual frame transfer to URAM but still LBA reload is processed only when the transfer from RxRAM to BMI is completed for that frame.
3 to 1	—	All 1	R	Reserved Whenever it is read, all bits 1 are read. The written value will be ignored.
0	LBA0	1b	R/W	Load Base Address 0(Tx0) 0b No pending load request 1b Pending load request This bit requests to set the current descriptor address of queue q (CDARq.CDA) to an entry of the descriptor base address table (DBAT.TA + 8*0). For the other description, refer to LBA4 bit of this register.

30.4.1.4 DMAC Status Register (CSR)

The CSR register is used to indicate the operating mode in which the DMAC is running and the individual communications states.

Bit	31	30	29	28	27	26	25	24	23	22	21	20	19	18	17	16
	—	—	—	—	—	—	—	—	—	—	TDUO	RPO	—	—	—	TPO
Initial Value	0	0	0	0	0	0	0	0	0	0	0	0	0	0	0	0
R/W	R	R	R	R	R	R	R	R	R	R	R	R	R	R	R	R
Bit	15	14	13	12	11	10	9	8	7	6	5	4	3	2	1	0
	—	—	—	—	—	RCSI	RDFDM	DTS	—	—	—	—	OPS[3:0]			
Initial Value	0	0	0	0	0	0	0	0	0	0	0	0	0	0	0	0
R/W	R	R	R	R	R	R	R	R	R	R	R	R	R	R	R	R

Bit	Bit Name	Initial Value	R/W	Description
31 to 22	—	All 0	R	Reserved Whenever it is read, 0 is read. The written value will be ignored.
21	TDUO	0b	R	Transmission Descriptor Update On-going 0b No pending descriptor update 1b Pending descriptor update in URAM This bit indicates that there is pending descriptor update for a transmit queue. When this bit is 1b, there are descriptors of already or currently processed transmit storage elements not updated in URAM. [Changing condition] This bit is set to 0b when leaving OPERATION mode. This bit is set to 0b when all transmit queue related storage elements processed. This bit is set to 1b when descriptor related status update procedure starts (descriptor update and SFR flagging).
20	RPO	0b	R	Reception Process On-going 0b No pending reception 1b Pending received frames in Reception FIFO This bit indicates that there is pending receive data for a receive queues. When this bit is 1b, there are frames in Reception FIFO that are not completely stored in URAM. [Changing condition] This bit is set to 0b when leaving OPERATION mode. This bit is set to 0b when a frame is completely stored in URAM, the descriptor update has been completed, and there are no pending frames in Reception FIFO for storage to URAM. This bit is set to 1b when a frame received by E-MAC is completely stored in Reception FIFO.
19 to 17	—	All 0	R	Reserved Whenever it is read, 0 is read. The written value will be ignored.
16	TPO	0b	R	Transmission Process On-going 0b No pending transmission 1b Pending frames for transmission This bit indicates that there is pending or on-going transmission process for transmit queue. When this bit is 1b, a frame fetch from the queue in URAM has been started or completed but this frame has not been completely transmitted by E-MAC Descriptor write back is not included in this bit.
15 to 11	—	All 0	R	Reserved Whenever it is read, 0 is read. The written value will be ignored.

Bit	Bit Name	Initial Value	R/W	Description
10	RCSI	0b	R	<p>Reference 250 MHz Clock is being Stopped Internally</p> <p>0b Reference 250 MHz Clock is being not stopped internally 1b Reference 250 MHz Clock is being stopped internally</p> <p>This bit indicates that Gigabit Ethernet Interface has stopped Reference 250 MHz Clock (clk_miitx_gtx_refclk) internally or not. When this bit is 1b, Internal Gated Clock Cell for Reference 250 MHz Clock is closed. During that time, this clock is not provided to internal logics.</p> <p>[Changing condition]</p> <p>This bit is set to 0b when the condition of input signal "refclk_stop" changes to 0b. This bit is set to 0b when leaving OPERATION mode. This bit is set to 0b when CCC.ERCS is 0b. This bit is set to 1b when the condition of output signal "refclk_stop_en" changes to 1b.</p>
9	RDFDM	0b	R	<p>Reception Descriptor Fetch Disable Monitor</p> <p>0b Reception Descriptor Fetch will happen 1b Reception Descriptor Fetch is stopped</p> <p>This bit is for monitoring. It can be used in order to confirm a state of Reception Descriptor Controller of DMAC. If this bit is '1', it means the fetch of Reception Descriptor from URAM by DMAC is completely stopped.</p> <p>[Changing condition]</p> <p>This bit is set to 0b when CCC.RDFD is 0b. This bit is set to 0b when RESET mode is entered. This bit is set to 1b when CCC.RDFD is 1b and fetch of Reception Descriptor from URAM is completely stopped.</p>
8	DTS	0b	R	<p>Data Transfer Suspended</p> <p>0b Access to URAM will happen 1b Access to URAM is suspended</p> <p>This bit indicates if DMAC is allowed to access URAM.</p> <p>[Changing condition]</p> <p>This bit is set to 0b when CCC.DTSR is 0b. This bit is set to 0b when leaving OPERATION mode. This bit is set to 1b when CCC.DTSR is 1b and there is no on-going URAM access.</p>
7 to 4	—	All 0	R	<p>Reserved</p> <p>Whenever it is read, 0 is read. The written value will be ignored.</p>
3 to 0	OPS	0001b	R	<p>OPERating mode Status</p> <p>0001b RESET 0010b CONFIG 0100b OPERATION others reserved</p> <p>These bits represent the current operating mode of DMAC.</p> <p>[Changing condition]</p> <p>These bits are updated when an operating mode changes is processed.</p>

30.4.1.5 Current Descriptor Address Register q (CDARq) (q = 0,4)

The CDARq register indicates the current descriptor address.

Bit	31	30	29	28	27	26	25	24	23	22	21	20	19	18	17	16
	CDA[31:16]															
Initial Value	0	0	0	0	0	0	0	0	0	0	0	0	0	0	0	0
R/W	R	R	R	R	R	R	R	R	R	R	R	R	R	R	R	R
Bit	15	14	13	12	11	10	9	8	7	6	5	4	3	2	1	0
	CDA[15:0]															
Initial Value	0	0	0	0	0	0	0	0	0	0	0	0	0	0	0	0
R/W	R	R	R	R	R	R	R	R	R	R	R	R	R	R	R	R

Bit	Bit Name	Initial Value	R/W	Description
31 to 0	CDA	All 0	R	<p>Current Descriptor Address</p> <p>Current descriptor address of transmission / receive queue q</p> <p>These bits indicate the address of the descriptor which is currently being processed by queue q or which will be processed when queue q gets active.</p> <p>For q=0 the addresses refer to the transmit queues.</p> <p>From q=4 the addresses refer to the receive queues.</p> <p><i>Note:</i> The current descriptor address cannot be used for HW/SW synchronization. CDARq.CDA may one or more descriptors ahead from information available in URAM.</p> <p>[Changing condition]</p> <p>These bits are set to 0 when leaving OPERATION mode.</p> <p>These bits are set to DBAT.TA + 8*q when entering OPERATION mode.</p> <p>These bits are set to DBAT.TA + 8*q when the load base address request of queue (DLR.LBA) has been processed.</p> <p>These bits are set to DESCR.DPTR when a link descriptor (LINK, LINKFIX) has been processed.</p> <p>These bits are incremented by the size of the descriptor control structure (8 for normal) when a frame data descriptor has been processed.</p>

30.4.1.6 Error Status Register (ESR)

Error Status Register

Bit	31	30	29	28	27	26	25	24	23	22	21	20	19	18	17	16
	—	—	—	—	—	—	—	—	—	—	—	—	—	—	—	—
Initial Value	0	0	0	0	0	0	0	0	0	0	0	0	0	0	0	0
R/W	R	R	R	R	R	R	R	R	R	R	R	R	R	R	R	R
Bit	15	14	13	12	11	10	9	8	7	6	5	4	3	2	1	0
	—	—	—	EIL	ET[3:0]			—	—	—	EQN[4:0]					
Initial Value	0	0	0	0	0	0	0	0	0	0	0	0	0	0	0	0
R/W	R	R	R	R	R	R	R	R	R	R	R	R	R	R	R	R

Bit	Bit Name	Initial Value	R/W	Description
31 to 13	—	All 0	R	Reserved Whenever it is read, 0 is read. The written value will be ignored.
12	EIL	0b	R	Error Information Lost 0b No loss of error information 1b Lost of error information detected This bit indicates that error information detected by Gigabit Ethernet Interface is lost because the previous reported error has not been processed by CPU. [Changing condition] This bit is set to 0b when leaving OPERATION mode. This bit is set to 0b when CPU writes 0b to EIS.QEF. This bit is set to 1b when the set condition of EIS.QEF is fulfilled while EIS.QEF is 1b.
11 to 8	ET	0000b	R	Error Type 0000b (0) Read descriptor from URAM 0001b (1) Write descriptor to URAM 0010b (2) Interpret read descriptor 0011b (3) Transmission FIFO is corrupted 0100b (4) Read data from URAM 0101b (5) Write data to URAM 0110b (6) Reading data from Reception FIFO 0111b (7) Reception FIFO is corrupted 1000b (8) Frame size error during reception detected 1001b (9) Reserved 1010b (10) Transmission FIFO Data access error others reserved These bits indicate details about the transfer stage which was handled when Gigabit Ethernet Interface has detected an error. When the fault is related to the read descriptor (ESR.ET=0 or 2), CPU needs to correct the faulty descriptor before the related queue can continue processing. In this case the queue halts at the faulty descriptor and CDARq.CDA (with q=ESR.EQN) identifies faulty descriptor. All other errors are transient in nature and may be corrected by continuation of HW or SW operation; so there is no strong demand on CPU interaction. The CPU should only evaluate these bits when EIS.QEF is 1b. [Changing condition] These bits are updated when the set condition of EIS.QEF is fulfilled and EIS.QEF is 0b.
7 to 5	—	All 0	R	Reserved Whenever it is read, 0 is read. The written value will be ignored.

Bit	Bit Name	Initial Value	R/W	Description
4 to 0	EQN	00000b	R	<p>Number of faulty queue</p> <p>These bits indicate the queue number which was being handled when Gigabit Ethernet Interface has detected an error.</p> <p>A fault reported for ESR.EQN= 0 is related to transmit queue.</p> <p>From ESR.EQN=4 the fault is related to receive queue.</p> <p>The CPU should only evaluate these bits when EIS.QEF is 1b.</p> <p>The CPU should not evaluate these bits when ESR.ET is 0011b, 0111b.</p> <p>[Changing condition]</p> <p>These bits are updated when the set condition of EIS.QEF is fulfilled and EIS.QEF is 0b.</p>

30.4.1.7 Receive Configuration Register (RCR)

The RCR register is used to make settings related to reception for the DMAC.

Bit	31	30	29	28	27	26	25	24	23	22	21	20	19	18	17	16
	—	RFCL[14:0]														
Initial Value	0	1	1	0	0	0	0	0	0	0	0	0	0	0	0	0
R/W	R	R/W	R/W	R/W	R/W	R/W	R/W	R/W	R/W	R/W	R/W	R/W	R/W	R/W	R/W	R/W
Bit	15	14	13	12	11	10	9	8	7	6	5	4	3	2	1	0
	—	—	—	—	—	—	—	—	—	—	—	—	—	—	—	EFFS
Initial Value	0	0	0	0	0	0	0	0	0	0	0	0	0	0	0	0
R/W	R	R	R	R	R	R	R	R	R	R	R	R	R	R	R	R/W

Bit	Bit Name	Initial Value	R/W	Description
31	—	0b	R	Reserved Whenever it is read, 0 is read. The written value will be ignored.
30 to 16	RFCL[14:0]	H'6000	R/W	Reception FIFO Critical Level Number of bytes stored in Reception FIFO before critical level is reached (RFCL[1:0] are fixed to 0). These bits define a fill level of the Reception FIFO in bytes to generate FIFO critical level reached warning notification (RIS1.RFWF). The CPU can only write to these bits if CSR.OPS is CONFIG. The CPU should only write values which are a multiple of 4 to these bits.
15 to 1	—	All 0	R	Reserved Whenever it is read, 0 is read. The written value will be ignored.
0	EFFS	0b	R/W	Enable Faulty Frame Storage 0b Storage of faulty frames disabled 1b Storage of faulty frames enabled (for debug) This bit enables the storage of received frames classified as faulty by the TOE or E-MAC. Faulty received frames will always be stored in receive queue. <i>Note:</i> DESCR.MSC informs about the reception fault detected by the TOE or E-MAC. The CPU can only write to this bit if CSR.OPS is CONFIG. <i>Note:</i> This bit is used only for debug. Do not set RCR.EFFS=1 during normal operation.

30.4.1.8 Reception Truncation Configuration Register I (RTC)

Reception Truncation Configuration register

Bit	31	30	29	28	27	26	25	24	23	22	21	20	19	18	17	16
	—	—	—	—	—	—	—	—	—	—	—	—	—	—	—	—
Initial Value	0	1	1	1	1	1	1	1	1	1	1	1	1	1	0	0
R/W	R	R	R	R	R	R	R	R	R	R	R	R	R	R	R	R
Bit	15	14	13	12	11	10	9	8	7	6	5	4	3	2	1	0
	—	MFL[14:0]														
Initial Value	0	1	1	1	1	1	1	1	1	1	1	1	1	1	0	0
R/W	R	R/W	R/W	R/W	R/W	R/W	R/W	R/W	R/W	R/W	R/W	R/W	R/W	R/W	R/W	R/W

Bit	Bit Name	Initial Value	R/W	Description
31	—	0b	R	Reserved Whenever it is read, 0 is read. The written value will be ignored.
30 to 18	—	All 1	R	Reserved Whenever it is read, all bits 1 are read. The written value will be ignored.
17 to 15	—	All 0	R	Reserved Whenever it is read, 0 is read. The written value will be ignored.
14 to 0	MFL	H'7FFC	R/W	Maximum Frame Length These bits define the maximum frame length (64 to 8k bytes) stored to URAM. When a frame received by E-MAC is truncated, CPU gets informed by EIS.QEF and frame size error (ESR.ET is 1000b). Additionally, the DESCR.TI in the updated descriptor is set to 1b. The CPU can only write to these bits if CSR.OPS is CONFIG. The CPU should only write values which are a multiple of 4 to these bits. The CPU should not write values less than 64 to these bits.

30.4.1.9 Transmit Configuration Register (TGC)

The TGC register is used to make settings related to transmission for the DMAC.

Bit	31	30	29	28	27	26	25	24	23	22	21	20	19	18	17	16
	—	—	—	—	—	—	—	—	—	—	—	—	—	—	—	—
Initial Value	0	0	0	0	0	0	0	0	0	0	1	0	0	0	1	0
R/W	R	R	R	R	R	R	R	R	R	R	R	R	R	R	R	R
Bit	15	14	13	12	11	10	9	8	7	6	5	4	3	2	1	0
	—	—	—	—	—	—	TBD[1:0]		—	—	—	—	—	—	—	—
Initial Value	0	0	1	0	0	0	1	0	0	0	0	0	0	0	0	0
R/W	R	R	R	R	R	R	R/W	R/W	R	R	R	R	R	R	R	R

Bit	Bit Name	Initial Value	R/W	Description
31 to 22	—	All 0	R	Reserved Whenever it is read, 0 is read. The written value will be ignored.
21	—	1b	R	Reserved Whenever it is read, 1 is read. The written value will be ignored.
20 to 18	—	All 0	R	Reserved Whenever it is read, 0 is read. The written value will be ignored.
17	—	1b	R	Reserved Whenever it is read, 1 is read. The written value will be ignored.
16 to 14	—	All 0	R	Reserved Whenever it is read, 0 is read. The written value will be ignored.
13	—	1b	R	Reserved Whenever it is read, 1 is read. The written value will be ignored.
12 to 10	—	All 0	R	Reserved Whenever it is read, 0 is read. The written value will be ignored.
9 to 8	TBD	10b	R/W	Transmission FIFO Depth This bit defines the depth of the Transmission FIFO used for transmit queue. Gigabit Ethernet Interface fetches up to TGC.TBD frames from URAM to Transmission FIFO for transmit queue. The CPU can only write "10b" to this bit. Frame transmission by E-MAC can start for transmission queue when at least one frame from transmit queue is available in Transmission FIFO. The CPU can only write to these bits if CSR.OPS is CONFIG.
7 to 0	—	All 0	R	Reserved Whenever it is read, 0 is read. The written value will be ignored.

30.4.1.10 Transmit Configuration Control Register (TCCR)

The TCCR register controls transmission by the DMAC and is used to make related settings.

Bit	31	30	29	28	27	26	25	24	23	22	21	20	19	18	17	16
	—	—	—	—	—	—	—	—	—	—	—	—	MFR2	MFEN2	MFR	MFEN
Initial Value	0	0	0	0	0	0	0	0	0	0	0	0	0	0	0	0
R/W	R	R	R	R	R	R	R	R	R	R	R	R	R/W	R/W	R/W	R/W
Bit	15	14	13	12	11	10	9	8	7	6	5	4	3	2	1	0
	—	—	—	—	—	—	—	—	—	—	—	—	—	—	—	TSRQ
Initial Value	0	0	0	0	0	0	0	0	0	0	0	0	0	0	0	0
R/W	R	R	R	R	R	R	R	R	R	R	R	R	R	R	R	R/W

Bit	Bit Name	Initial Value	R/W	Description
31 to 20	—	All 0	R	Reserved Whenever it is read, 0 is read. The written value will be ignored.
19	MFR2	0b	R/W	MAC status FIFO2 Release 0b No requests to MAC status FIFO2 1b Release oldest entry of MAC status FIFO2 This bit releases the oldest entry of the MAC status FIFO2. When 1b is written to this bit, Gigabit Ethernet Interface gets informed that CPU has processed the oldest MAC status FIFO2 entry as visible in MFA2 register. The oldest entry is removed from MAC status FIFO2. This bit is always read as 0b. <i>Note:</i> Do not use the function of this bit in the Duplex Mode (CXR20.DPM=1).
18	MFEN2	0b	R/W	MAC status FIFO2 Enable 0b Disabled 1b Enabled This bit enables the storage of transmission status information (the E-MAC flags for frame transmission) in the MAC status FIFO2. When this bit is set to 0b all pending FIFO entries are removed. <i>Note:</i> Do not use the function of this bit in the Duplex Mode (CXR20.DPM=1).
17	MFR	0b	R/W	MAC status FIFO Release 0b No request to MAC status FIFO 1b Release oldest entry of MAC status FIFO This bit releases the oldest entry of the MAC status FIFO. When 1b is written to this bit, DMAC gets informed that CPU has processed the oldest MAC status FIFO entry as visible in MFA register. The oldest entry is removed from MAC status FIFO. This bit is always read as 0b.
16	MFEN	0b	R/W	MAC status FIFO Enable 0b Disabled 1b Enabled This bit enables the storage of transmission status information (the TOE flags for frame transmission) in the MAC status FIFO. Additionally, CPU can control the status storage for each frame provided for transmission using DESCR.MSR. When this bit is set to 0b all pending FIFO entries are removed.
15 to 1	—	All 0	R	Reserved Whenever it is read, 0 is read. The written value will be ignored.

Bit	Bit Name	Initial Value	R/W	Description
0	TSRQ	0b	R/W	<p>Transmission Start Request Queue</p> <p>0b Transmission queue empty or stopped 1b Pending frames in queue to fetch</p> <p>This bit defines that frames, provided by CPU in transmit queue in URAM should be transmitted.</p> <p>When this bit is 1b, there are pending frames in transmit queue which have not been fetched to the Transmission FIFO.</p> <p><i>Note:</i> The transmission start request cannot be used for HW/SW synchronization. TCCR.TSRQ may be cleared before frame data is completely fetched from URAM.</p> <p><i>Note:</i> The frame transmission by E-MAC is decoupled from the fetching to the Transmission FIFO. Transmission scheduling for a queue depends on the transmission priority. CSR.TPO gives an indication about pending transmissions.</p> <p>The CPU can only write to this bit if CSR.OPS is OPERATION. The CPU can only write 1b to this bit. [Changing condition] This bit is set to 0b when leaving OPERATION mode. This bit is set to 1b when CPU writes 1b to it. This bit is set to 0b when DMAC has processed an EEMPTY, FEMPTY or LEMPTY descriptor (no data available). This bit is set to 0b when DMAC has processed an EOS descriptor (end of set). This bit is set to 0b when DMAC has processed a faulty descriptor. This bit is set to 0b when CCC.OPC is 01b and there is no on-going fetch transfer for queue.</p>

30.4.1.11 Transmit Status Register (TSR)

The TSR register indicates the state of transmission by the DMAC.

Bit	31	30	29	28	27	26	25	24	23	22	21	20	19	18	17	16
	—	—	—	MFFL2[4:0]				—	—	—	MFFL[4:0]					
Initial Value	0	0	0	0	0	0	0	0	0	0	0	0	0	0	0	0
R/W	R	R	R	R	R	R	R	R	R	R	R	R	R	R	R	R
Bit	15	14	13	12	11	10	9	8	7	6	5	4	3	2	1	0
	—	—	—	—	—	—	—	—	—	—	—	—	—	—	—	—
Initial Value	0	0	0	0	0	0	0	0	0	0	0	0	0	0	0	0
R/W	R	R	R	R	R	R	R	R	R	R	R	R	R	R	R	R

Bit	Bit Name	Initial Value	R/W	Description
31 to 29	—	All 0	R	Reserved When read, the initial value is read. When writing, be sure to write the initial value. Operation is not guaranteed if a value other than the initial value is written.
28 to 24	MFFL2	0000b	R	MAC status FIFO2 Fill Level Number of entries stored in the MAC status FIFO2 These bits indicate the number of entries available in the MAC status FIFO2. If this value is 0, the FIFO2 is empty. If this value is 16, the FIFO2 is full. The values 17 to 31 are reserved. [Changing condition] These bits are set to 0 when leaving OPERATION mode. These bits are set to 0 when TCCR.MFEN2 is 0b. This value is incremented when TCCR.MFEN2 is 1b, TSR.MFFL2 is not 16, and E-MAC detects an error during transmission of frame. This value is decremented when 1b is written to TCCR.MFR2 and TSR.MFFL2 is not 0.
23 to 21	—	All 0	R	Reserved Whenever it is read, 0 is read. The written value will be ignored.
20 to 16	MFFL	00000b	R	MAC status FIFO Fill Level Number of entries stored in the MAC status FIFO These bits indicate the number of entries available in the MAC status FIFO. If this value is 0, the FIFO is empty. If this value is 16, the FIFO is full. The values 17 to 31 are reserved. [Changing condition] These bits are set to 0 when leaving OPERATION mode. These bits are set to 0 when TCCR.MFEN is 0b. This value is incremented when frame with DESCR.MSR has been transmitted to TOE, TCCR.MFEN is 1b and TSR.MFFL is not 16. This value is decremented when 1b is written to TCCR.MFR and TSR.MFFL is not 0.
15 to 0	—	All 0	R	Reserved Whenever it is read, 0 is read. The written value will be ignored.

30.4.1.12 MAC status FIFO Access Register (MFA)

MAC status FIFO Access register

Bit	31	30	29	28	27	26	25	24	23	22	21	20	19	18	17	16		
	—	—	—	—	—	—	MST[9:0]											
Initial Value	0	0	0	0	0	0	0	0	0	0	0	0	0	0	0	0		
R/W	R	R	R	R	R	R	R	R	R	R	R	R	R	R	R	R		
Bit	15	14	13	12	11	10	9	8	7	6	5	4	3	2	1	0		
	—	—	—	—	—	—	MSV[9:0]											
Initial Value	0	0	0	0	0	0	0	0	0	0	0	0	0	0	0	0		
R/W	R	R	R	R	R	R	R	R	R	R	R	R	R	R	R	R		

Bit	Bit Name	Initial Value	R/W	Description
31 to 26	—	All 0	R	Reserved Whenever it is read, 0 is read. The written value will be ignored.
25to 16	MST	H'00	R	MAC Status Tag Tag number from descriptor identifying the frame MAC status relation These bits represent the DESCR.TAG bits from the descriptor defining the data for frame transmission. The tag is used to get the relation between the frame inside a transmit queue and the TOE status available in the FIFO (MFA.MSV). The CPU should not read these bits when TSR.MFFL is 0. [Changing condition] These bits are updated when the first entry is stored in FIFO (TSR.MFFL changes from 0 to 1). These bits are updated when the oldest entry is released (writing 1b to TCCR.MFR). These bits are updated when the FIFO is overwritten (a frame with DESCR.MSR in descriptor has been transmitted to TOE, TCCR.MFEN is 1b and TSR.MFFL is 16). Note for verification: These bits are set to 0 when leaving OPERATION mode.
15 to 10	—	All 0	R	Reserved Whenever it is read, 0 is read. The written value will be ignored.
9to 0	MSV	H'00	R	MAC status value These bits represent the TOE status bits as stored in the oldest MAC status FIFO entry. MSV [9] Unsupported transmission frame MSV [8:0] Reserved The CPU should not read these bits when TSR.MFFL is 0. [Changing condition] These bits are updated when the first entry is stored in FIFO (TSR.MFFL changes from 0 to 1). These bits are updated when the oldest entry is released (writing 1b to TCCR.MFR). These bits are updated when the FIFO overwritten (a frame with DESCR.MSR in descriptor has been transmitted to TOE, TCCR.MFEN is 1b and TSR.MFFL is 16). Note for verification: These bits are set to 0 when leaving OPERATION mode.

30.4.1.13 MAC status FIFO Access 2 Register (MFA2)

MAC status FIFO Access 2 register

Bit	31	30	29	28	27	26	25	24	23	22	21	20	19	18	17	16
	—	—	—	—	—	—	—	—	—	—	—	—	—	—	—	—
Initial Value	0	0	0	0	0	0	0	0	0	0	0	0	0	0	0	0
R/W	R	R	R	R	R	R	R	R	R	R	R	R	R	R	R	R
Bit	15	14	13	12	11	10	9	8	7	6	5	4	3	2	1	0
	—	—	—	—	—	—	—	MSV2[8:0]								
Initial Value	0	0	0	0	0	0	0	0	0	0	0	0	0	0	0	0
R/W	R	R	R	R	R	R	R	R	R	R	R	R	R	R	R	R

Bit	Bit Name	Initial Value	R/W	Description
31 to 9	—	All 0	R	Reserved Whenever it is read, 0 is read. The written value will be ignored.
8 to 0	MSV2	H'00	R	MAC Status Value2 These bits represent the MAC status bits as stored in the oldest MAC status FIFO2 entry. MSV [8] abort information MSV [7:3] Reserved MSV [2] Carrier lost during frame transmission MSV [1] Delay collision MSV [0] Transmission time out The CPU should not read these bits when TSR.MFFL2 is 0. [Changing condition] These bits are updated when the first entry is stored in FIFO2 (TSR.MFFL2 changes from 0 to 1). These bits are updated when the oldest entry is released (writing 1b to TCCR.MFR2). These bits are updated when the FIFO2 is overwritten when TCCR.MFEN2 is 1b, TSR.MFFL2 is 16, and E-MAC detects an error during transmission of frame.

30.4.1.14 Descriptor Interrupt Status Register (DIS)

The DIS register indicates the state of descriptor interrupts.

Bit	31	30	29	28	27	26	25	24	23	22	21	20	19	18	17	16
	—	—	—	—	—	—	—	—	—	—	—	—	—	—	—	—
Initial Value	0	0	0	0	0	0	0	0	0	0	0	0	0	0	0	0
R/W	R	R	R	R	R	R	R	R	R	R	R	R	R	R	R	R
Bit	15	14	13	12	11	10	9	8	7	6	5	4	3	2	1	0
	DPF15	DPF14	DPF13	DPF12	DPF11	DPF10	DPF9	DPF8	DPF7	DPF6	DPF5	DPF4	DPF3	DPF2	DPF1	—
Initial Value	0	0	0	0	0	0	0	0	0	0	0	0	0	0	0	0
R/W	R/W	R/W	R/W	R/W	R/W	R/W	R/W	R/W	R/W	R/W	R/W	R/W	R/W	R/W	R/W	R

Bit	Bit Name	Initial Value	R/W	Description
31 to 16	—	All 0	R	Reserved Whenever it is read, 0 is read. The written value will be ignored.
15 to 1	DPFi	All 0	R/W	Descriptor Processed Flag i (i = 1 to 15) 0b No interrupt pending 1b Descriptor interrupt pending This bit indicates that a descriptor in a reception or transmit queue has been processed where DESC.R.DIE is i. <i>Note:</i> When DESC.R.DIE is 0000b, no descriptor interrupt is generated. <i>Note:</i> When DESC.R.DIE is 0001b, in addition a queue specific descriptor interrupt is generated. The CPU can only write 0b to this bit. [Changing condition] This bit is set to 0b when leaving OPERATION mode. This bit is set to 1b when a descriptor has been processed where DESC.R.DIE is i.
0	—	0b	R	Reserved Whenever it is read, 0 is read. The written value will be ignored.

30.4.1.15 Descriptor Interrupt Control Register (DIC)

The DIC register is used to control descriptor interrupts 1 to 15.

Bit	31	30	29	28	27	26	25	24	23	22	21	20	19	18	17	16
	—	—	—	—	—	—	—	—	—	—	—	—	—	—	—	—
Initial Value	0	0	0	0	0	0	0	0	0	0	0	0	0	0	0	0
R/W	R	R	R	R	R	R	R	R	R	R	R	R	R	R	R	R
Bit	15	14	13	12	11	10	9	8	7	6	5	4	3	2	1	0
	DPE15	DPE14	DPE13	DPE12	DPE11	DPE10	DPE9	DPE8	DPE7	DPE6	DPE5	DPE4	DPE3	DPE2	DPE1	—
Initial Value	0	0	0	0	0	0	0	0	0	0	0	0	0	0	0	0
R/W	R/W	R/W	R/W	R/W	R/W	R/W	R/W	R/W	R/W	R/W	R/W	R/W	R/W	R/W	R/W	R

Bit	Bit Name	Initial Value	R/W	Description
31 to 16	—	All 0	R	Reserved Whenever it is read, 0 is read. The written value will be ignored.
15 to 1	DPEi	All 0	R/W	Descriptor Processed interrupt Enable i (i = 1 to 15) 0b Disabled 1b Enabled While this bit is 1b an interrupt will be generated when DIS.DPFi is 1b. [Changing condition] This bit is set to 0b when writing 1b to DID.DPDi. This bit is set to 1b when writing 1b to DIE.DPSi.
0	—	0b	R	Reserved Whenever it is read, 0 is read. The written value will be ignored.

30.4.1.16 Descriptor Interrupt Enable Register (DIE)

The DIE register set to 1 each bit in descriptor interrupt control register (DIC).

Bit	31	30	29	28	27	26	25	24	23	22	21	20	19	18	17	16
	—	—	—	—	—	—	—	—	—	—	—	—	—	—	—	—
Initial Value	0	0	0	0	0	0	0	0	0	0	0	0	0	0	0	0
R/W	R	R	R	R	R	R	R	R	R	R	R	R	R	R	R	R
Bit	15	14	13	12	11	10	9	8	7	6	5	4	3	2	1	0
	DPS15	DPS14	DPS13	DPS12	DPS11	DPS10	DPS9	DPS8	DPS7	DPS6	DPS5	DPS4	DPS3	DPS2	DPS1	—
Initial Value	0	0	0	0	0	0	0	0	0	0	0	0	0	0	0	0
R/W	R/W	R/W	R/W	R/W	R/W	R/W	R/W	R/W	R/W	R/W	R/W	R/W	R/W	R/W	R/W	R

Bit	Bit Name	Initial Value	R/W	Description
31 to 16	—	All 0	R	Reserved Whenever it is read, 0 is read. The written value will be ignored.
15 to 1	DPSi	All 0	R/W	Descriptor Processed interrupt Set i (i = 1 to 15) 0b No change of DIC.DPEi 1b Set DIC.DPEi to 1b This bit supports interrupt enable. It controls set of DIC.DPEi. This bit is always read as 0b.
0	—	0b	R	Reserved Whenever it is read, 0 is read. The written value will be ignored.

30.4.1.17 Descriptor Interrupt Disable Register (DID)

The DID register set to 0 each bit in descriptor interrupt control register (DIC).

Bit	31	30	29	28	27	26	25	24	23	22	21	20	19	18	17	16
	—	—	—	—	—	—	—	—	—	—	—	—	—	—	—	—
Initial Value	0	0	0	0	0	0	0	0	0	0	0	0	0	0	0	0
R/W	R	R	R	R	R	R	R	R	R	R	R	R	R	R	R	R
Bit	15	14	13	12	11	10	9	8	7	6	5	4	3	2	1	0
	DPD15	DPD14	DPD13	DPD12	DPD11	DPD10	DPD9	DPD8	DPD7	DPD6	DPD5	DPD4	DPD3	DPD2	DPD1	—
Initial Value	0	0	0	0	0	0	0	0	0	0	0	0	0	0	0	0
R/W	R/W	R/W	R/W	R/W	R/W	R/W	R/W	R/W	R/W	R/W	R/W	R/W	R/W	R/W	R/W	R

Bit	Bit Name	Initial Value	R/W	Description
31 to 16	—	All 0	R	Reserved Whenever it is read, 0 is read. The written value will be ignored.
15 to 1	DPDi	All 0	R/W	Descriptor Processed interrupt Disable i (i = 1 to 15) 0b No change of DIC.DPEi 1b Set DIC.DPEi to 0b This bit supports interrupt enable. It controls set of DIC.DPEi. This bit is always read as 0b.
0	—	0b	R	Reserved Whenever it is read, 0 is read. The written value will be ignored.

30.4.1.18 Error Interrupt Status Register (EIS)

The EIS register indicates the states of DMAC-related error interrupts.

Bit	31	30	29	28	27	26	25	24	23	22	21	20	19	18	17	16
	—	—	—	—	—	—	—	—	—	—	—	—	—	—	—	QFS
Initial Value	0	0	0	0	0	0	0	0	0	0	0	0	0	0	0	0
R/W	R	R	R	R	R	R	R	R	R	R	R	R	R	R	R	R
Bit	15	14	13	12	11	10	9	8	7	6	5	4	3	2	1	0
	—	—	—	—	MFFF2	—	MFFF	—	—	—	—	—	—	QEF	MTEF	MREF
Initial Value	0	0	0	0	0	0	0	0	0	0	0	0	0	0	0	0
R/W	R	R	R	R	R/W	R	R/W	R	R	R	R	R	R	R/W	R/W	R/W

Bit	Bit Name	Initial Value	R/W	Description
31 to 17	—	All 0	R	Reserved Whenever it is read, 0 is read. The written value will be ignored.
16	QFS	0b	R	Queue Full Summary 0b No interrupt pending 1b Queue full interrupt pending Summary bit to indicate that at least one queue is full. [Changing condition] This bit is set when any matching pair of RIC2.QFE enable and RIS2.QFF flag are both 1b; or when both the RIS2.RFFF flag and RIC2.RFFE enable are 1b.
15 to 12	—	All 0	R	Reserved Whenever it is read, 0 is read. The written value will be ignored.
11	MFFF2	0b	R/W	MAC status FIFO2 Full Flag 0b No interrupt pending 1b MAC status FIFO2 full, oldest MAC status lost MAC status FIFO2 Full Flag This bit indicates that a transmission MAC status is overwritten because the MAC status FIFO2 is full (overwrite condition). The CPU can only write 0b to this bit. [Changing condition] This bit is set to 0b when leaving OPERATION mode. This bit is set to 1b when TCCR.MFEN2 is 1b, TSR.MFFL2 is 16, and E-MAC detects an error during transmission of frame.
10	—	0b	R	Reserved Whenever it is read, 0 is read. The written value will be ignored.
9	MFFF	0b	R/W	MAC status FIFO Full Flag 0b No interrupt pending 1b MAC status FIFO full, oldest MAC status lost This bit indicates that a transmission MAC status is overwritten because the MAC status FIFO is full (overwrite condition). The CPU can only write 0b to this bit. [Changing condition] This bit is set to 0b when leaving OPERATION mode. This bit is set to 1b when frame with DESCR.MSR has been transmitted to TOE, TCCR.MFEN is 1b and TSR.MFFL is 16.
8 to 3	—	All 0	R	Reserved Whenever it is read, 0 is read. The written value will be ignored.

Bit	Bit Name	Initial Value	R/W	Description
2	QEF	0b	R/W	<p>Queue Error Flag</p> <p>0b No interrupt pending 1b Interrupt pending</p> <p>This bit indicates that an error has been detected while processing receive or transmit queue.</p> <p>Detail about the detected error is indicated by ESR.</p> <p>The CPU can only write 0b to this bit.</p> <p>[Changing condition]</p> <p>This bit is set to 0b when leaving OPERATION mode.</p> <p>This bit is set to 1b when an error condition is detected.</p>
1	MTEF	0b	R/W	<p>MAC Transmission Error Flag</p> <p>0b No interrupt pending 1b MAC has reported an error during transmission</p> <p>This bit indicates that the E-MAC has detected a fault during transmission.</p> <p>For detail, the E-MAC registers have to be checked.</p> <p>The CPU can only write 0b to this bit.</p> <p>[Changing condition]</p> <p>This bit is set to 0b when leaving OPERATION mode.</p> <p>This bit is set to 1b when E-MAC detects an error during frame transmission.</p>
0	MREF	0b	R/W	<p>MAC Reception Error Flag</p> <p>0b No interrupt pending 1b MAC has reported an error during reception</p> <p>This bit indicates that the E-MAC has detected a fault during reception.</p> <p>For detail, the E-MAC registers have to be checked.</p> <p><i>Note:</i> When the storage of faulty received frames (RCR.EFFS) is enabled, the E-MAC error code is stored in the descriptor (DESCR.MSC). By evaluating this information CPU can identify corrupted frames in URAM.</p> <p>The CPU can only write 0b to this bit.</p>

30.4.1.19 Error Interrupt Control Register (EIC)

The EIC register controls the DMAC-related error interrupts.

Bit	31	30	29	28	27	26	25	24	23	22	21	20	19	18	17	16
	—	—	—	—	—	—	—	—	—	—	—	—	—	—	—	—
Initial Value	0	0	0	0	0	0	0	0	0	0	0	0	0	0	0	0
R/W	R	R	R	R	R	R	R	R	R	R	R	R	R	R	R	R
Bit	15	14	13	12	11	10	9	8	7	6	5	4	3	2	1	0
	—	—	—	—	MFFE2	—	MFFE	—	—	—	—	—	—	QEE	MTEE	MREE
Initial Value	0	0	0	0	0	0	0	0	0	0	0	0	0	0	0	0
R/W	R	R	R	R	R/W	R	R/W	R	R	R	R	R	R	R/W	R/W	R/W

Bit	Bit Name	Initial Value	R/W	Description
31 to 12	—	All 0	R	Reserved Whenever it is read, 0 is read. The written value will be ignored.
11	MFFE2	0b	R/W	MAC status FIFO2 Full interrupt Enable 0b Disabled 1b Enabled While this bit is 1b an interrupt will be generated when EIS.MFFF2 is 1b. [Changing condition] This bit is set to 0b when writing 1b to EID.MFFD2. This bit is set to 1b when writing 1b to EIE.MFFS2.
10	—	0b	R	Reserved Whenever it is read, 0 is read. The written value will be ignored.
9	MFFE	0b	R/W	MAC status FIFO Full interrupt Enable 0b Disabled 1b Enabled While this bit is 1b an interrupt will be generated when EIS.MFFF is 1b. [Changing condition] This bit is set to 0b when writing 1b to EID.MFFD. This bit is set to 1b when writing 1b to EIE.MFFS.
8 to 3	—	All 0	R	Reserved Whenever it is read, 0 is read. The written value will be ignored.
2	QEE	0b	R/W	Queue Error interrupt Enable 0b Disabled 1b Enabled While this bit is 1b an interrupt will be generated when EIS.QEF is 1b. [Changing condition] This bit is set to 0b when writing 1b to EID.QED. This bit is set to 1b when writing 1b to EIE.QES.
1	MTEE	0b	R/W	MAC Transmission Error interrupt Enable 0b Disabled 1b Enabled While this bit is 1b an interrupt will be generated when EIS.MTEF is 1b. [Changing condition] This bit is set to 0b when writing 1b to EID.MTED. This bit is set to 1b when writing 1b to EIE.MTES.

Bit	Bit Name	Initial Value	R/W	Description
0	MREE	0b	R/W	MAC Reception Error interrupt Enable 0b Disabled 1b Enabled While this bit is 1b an interrupt will be generated when EIS.MREF is 1b. [Changing condition] This bit is set to 0b when writing 1b to EID.MRED. This bit is set to 1b when writing 1b to EIE.MRES.

30.4.1.20 Error Interrupt Enable Register (EIE)

The EIE register set to 1 each bit in error interrupt control register (EIC).

Bit	31	30	29	28	27	26	25	24	23	22	21	20	19	18	17	16
	—	—	—	—	—	—	—	—	—	—	—	—	—	—	—	—
Initial Value	0	0	0	0	0	0	0	0	0	0	0	0	0	0	0	0
R/W	R	R	R	R	R	R	R	R	R	R	R	R	R	R	R	R
Bit	15	14	13	12	11	10	9	8	7	6	5	4	3	2	1	0
	—	—	—	—	MFFS2	—	MFFS	—	—	—	—	—	—	QES	MTES	MRES
Initial Value	0	0	0	0	0	0	0	0	0	0	0	0	0	0	0	0
R/W	R	R	R	R	R/W	R	R/W	R	R	R	R	R	R	R/W	R/W	R/W

Bit	Bit Name	Initial Value	R/W	Description
31 to 12	—	All 0	R	Reserved Whenever it is read, 0 is read. The written value will be ignored.
11	MFFS2	0b	R/W	MAC status FIFO2 Full interrupt Set 0b No change of EIC.MFFE2 1b Set EIC.MFFE2 to 1b This bit supports interrupt enable. It controls set of EIC.MFFE2. This bit is always read as 0b.
10	—	0b	R	Reserved Whenever it is read, 0 is read. The written value will be ignored.
9	MFFS	0b	R/W	MAC status FIFO Full interrupt Set 0b No change of EIC.MFFE 1b Set EIC.MFFE to 1b This bit supports interrupt enable. It controls set of EIC.MFFE. This bit is always read as 0b.
8 to 3	—	All 0	R	Reserved Whenever it is read, 0 is read. The written value will be ignored.
2	QES	0b	R/W	Queue Error interrupt Set 0b No change of EIC.QEE 1b Set EIC.QEE to 1b This bit supports interrupt enable. It controls set of EIC.QEE. This bit is always read as 0b.
1	MTES	0b	R/W	MAC Transmission Error interrupt Set 0b No change of EIC.MTEE 1b Set EIC.MTEE to 1b This bit supports interrupt enable. It controls set of EIC.MTEE. This bit is always read as 0b.
0	MRES	0b	R/W	MAC Reception Error interrupt Set 0b No change of EIC.MREE 1b Set EIC.MREE to 1b This bit supports interrupt enable. It controls set of EIC.MREE. This bit is always read as 0b.

30.4.1.21 Error Interrupt Disable Register (EID)

The EID register set to 0 each bit in error interrupt control register (EIC).

Bit	31	30	29	28	27	26	25	24	23	22	21	20	19	18	17	16
	—	—	—	—	—	—	—	—	—	—	—	—	—	—	—	—
Initial Value	0	0	0	0	0	0	0	0	0	0	0	0	0	0	0	0
R/W	R	R	R	R	R	R	R	R	R	R	R	R	R	R	R	R
Bit	15	14	13	12	11	10	9	8	7	6	5	4	3	2	1	0
	—	—	—	—	MFFD2	—	MFFD	—	—	—	—	—	—	QED	MTED	MRED
Initial Value	0	0	0	0	0	0	0	0	0	0	0	0	0	0	0	0
R/W	R	R	R	R	R/W	R	R/W	R	R	R	R	R	R	R/W	R/W	R/W

Bit	Bit Name	Initial Value	R/W	Description
31 to 12	—	All 0	R	Reserved Whenever it is read, 0 is read. The written value will be ignored.
11	MFFD2	0b	R/W	MAC status FIFO2 Full interrupt Disable 0b No change of EIC.MFFE 1b Set EIC.MFFE to 0b This bit supports interrupt enable. It controls set of EIC.MFFE2. This bit is always read as 0b.
10	—	0b	R	Reserved Whenever it is read, 0 is read. The written value will be ignored.
9	MFFD	0b	R/W	MAC status FIFO Full interrupt Disable 0b No change of EIC.MFFE 1b Set EIC.MFFE to 0b This bit supports interrupt enable. It controls set of EIC.MFFE. This bit is always read as 0b.
8 to 3	—	All 0	R	Reserved Whenever it is read, 0 is read. The written value will be ignored.
2	QED	0b	R/W	Queue Error interrupt Disable 0b No change of EIC.QEE 1b Set EIC.QEE to 0b This bit supports interrupt enable. It controls set of EIC.QEE. This bit is always read as 0b.
1	MTED	0b	R/W	MAC Transmission Error interrupt Disable 0b No change of EIC.MTEE 1b Set EIC.MTEE to 0b This bit supports interrupt enable. It controls set of EIC.MTEE. This bit is always read as 0b.
0	MRED	0b	R/W	MAC Reception Error interrupt Disable 0b No change of EIC.MREE 1b Set EIC.MREE to 0b This bit supports interrupt enable. It controls set of EIC.MREE. This bit is always read as 0b.

30.4.1.22 Receive Interrupt Status Register 0 (RIS0)

The RIS0 register indicates the states of the DMAC receive interrupts.

Bit	31	30	29	28	27	26	25	24	23	22	21	20	19	18	17	16
	—	—	—	—	—	—	—	—	—	—	—	—	—	—	—	—
Initial Value	0	0	0	0	0	0	0	0	0	0	0	0	0	0	0	0
R/W	R	R	R	R	R	R	R	R	R	R	R	R	R	R	R	R
Bit	15	14	13	12	11	10	9	8	7	6	5	4	3	2	1	0
	—	—	—	—	—	—	—	—	—	—	—	—	—	—	—	FRF
Initial Value	0	0	0	0	0	0	0	0	0	0	0	0	0	0	0	0
R/W	R	R	R	R	R	R	R	R	R	R	R	R	R	R	R	R/W

Bit	Bit Name	Initial Value	R/W	Description
31 to 1	—	All 0	R	Reserved Whenever it is read, 0 is read. The written value will be ignored.
0	FRF	0b	R/W	Frame Received Flag 0b No interrupt pending 1b New frame data is available in URAM This bit indicates that in receive queue r a frame is stored, and data is available to be processed by CPU. The CPU can only write 0b to this bit. [Changing condition] This bit is set to 0b when leaving OPERATION mode. This bit is set to 1b when a frame is stored in receive queue.

30.4.1.23 Receive Interrupt Control Register 0 (RIC0)

The RIC0 register controls the DMAC receive interrupts.

Bit	31	30	29	28	27	26	25	24	23	22	21	20	19	18	17	16
	—	—	—	—	—	—	—	—	—	—	—	—	—	—	—	—
Initial Value	0	0	0	0	0	0	0	0	0	0	0	0	0	0	0	0
R/W	R	R	R	R	R	R	R	R	R	R	R	R	R	R	R	R
Bit	15	14	13	12	11	10	9	8	7	6	5	4	3	2	1	0
	—	—	—	—	—	—	—	—	—	—	—	—	—	—	—	FRE
Initial Value	0	0	0	0	0	0	0	0	0	0	0	0	0	0	0	0
R/W	R	R	R	R	R	R	R	R	R	R	R	R	R	R	R	R/W

Bit	Bit Name	Initial Value	R/W	Description
31 to 1	—	All 0	R	Reserved Whenever it is read, 0 is read. The written value will be ignored.
0	FRE	0b	R/W	Frame Received interrupt Enable 0b Disabled 1b Enabled While this bit is 1b an interrupt will be generated when RIS0.FRF is 1b. [Changing condition] This bit is set to 0b when writing 1b to RID0.FRD. This bit is set to 1b when writing 1b to RIE0.FRS.

30.4.1.24 Receive Interrupt Enable Register 0 (RIE0)

The RIE0 register set to 1 each bit in receive interrupt control register (RIC0).

Bit	31	30	29	28	27	26	25	24	23	22	21	20	19	18	17	16
	—	—	—	—	—	—	—	—	—	—	—	—	—	—	—	—
Initial Value	0	0	0	0	0	0	0	0	0	0	0	0	0	0	0	0
R/W	R	R	R	R	R	R	R	R	R	R	R	R	R	R	R	R
Bit	15	14	13	12	11	10	9	8	7	6	5	4	3	2	1	0
	—	—	—	—	—	—	—	—	—	—	—	—	—	—	—	FRS
Initial Value	0	0	0	0	0	0	0	0	0	0	0	0	0	0	0	0
R/W	R	R	R	R	R	R	R	R	R	R	R	R	R	R	R	R/W

Bit	Bit Name	Initial Value	R/W	Description
31 to 1	—	All 0	R	Reserved Whenever it is read, 0 is read. The written value will be ignored.
0	FRS	0b	R/W	Frame Received interrupt Set r 0b No change of RIC0.FRE 1b Set RIC0.FRE to 1b This bit supports interrupt enable. It controls set of RIC0.FRE. This bit is always read as 0b.

30.4.1.25 Receive Interrupt Disable Register 0 (RID0)

The RID0 register set to 0 each bit in receive interrupt control register (RIC0).

Bit	31	30	29	28	27	26	25	24	23	22	21	20	19	18	17	16
	—	—	—	—	—	—	—	—	—	—	—	—	—	—	—	—
Initial Value	0	0	0	0	0	0	0	0	0	0	0	0	0	0	0	0
R/W	R	R	R	R	R	R	R	R	R	R	R	R	R	R	R	R
Bit	15	14	13	12	11	10	9	8	7	6	5	4	3	2	1	0
	—	—	—	—	—	—	—	—	—	—	—	—	—	—	—	FRD
Initial Value	0	0	0	0	0	0	0	0	0	0	0	0	0	0	0	0
R/W	R	R	R	R	R	R	R	R	R	R	R	R	R	R	R	R/W

Bit	Bit Name	Initial Value	R/W	Description
31 to 1	—	All 0	R	Reserved Whenever it is read, 0 is read. The written value will be ignored.
0	FRD	0b	R/W	Frame Received interrupt Disable 0b No change of RIC0.FRE 1b Set RIC0.FRE to 0b This bit supports interrupt enable. It controls set of RIC0.FRE. This bit is always read as 0b.

30.4.1.26 Receive Interrupt Status Register 1 (RIS1)

The RIS1 register indicates the states of the DMAC receive interrupts.

Bit	31	30	29	28	27	26	25	24	23	22	21	20	19	18	17	16
	RFWF	—	—	—	—	—	—	—	—	—	—	—	—	—	—	—
Initial Value	0	0	0	0	0	0	0	0	0	0	0	0	0	0	0	0
R/W	R/W	R	R	R	R	R	R	R	R	R	R	R	R	R	R	R
Bit	15	14	13	12	11	10	9	8	7	6	5	4	3	2	1	0
	—	—	—	—	—	—	—	—	—	—	—	—	—	—	—	—
Initial Value	0	0	0	0	0	0	0	0	0	0	0	0	0	0	0	0
R/W	R	R	R	R	R	R	R	R	R	R	R	R	R	R	R	R

Bit	Bit Name	Initial Value	R/W	Description
31	RFWF	0b	R/W	Reception FIFO Warning Flag 0b No interrupt pending 1b Reception FIFO warning level reached This bit indicates that the Reception FIFO has reached the configured critical warning level. The CPU can only write 0b to this bit. [Changing condition] This bit is set to 0b when leaving OPERATION mode. This bit is set to 1b when a complete frame is received in the Reception FIFO and the fill level goes above the configured critical warning level during reception of this frame (RCR.RFCL).
30 to 0	—	All 0	R	Reserved Whenever it is read, 0 is read. The written value will be ignored.

30.4.1.27 Receive Interrupt Control Register 1 (RIC1)

The RIC1 register controls the DMAC receive interrupts.

Bit	31	30	29	28	27	26	25	24	23	22	21	20	19	18	17	16
	RFWE	—	—	—	—	—	—	—	—	—	—	—	—	—	—	—
Initial Value	0	0	0	0	0	0	0	0	0	0	0	0	0	0	0	0
R/W	R/W	R	R	R	R	R	R	R	R	R	R	R	R	R	R	R
Bit	15	14	13	12	11	10	9	8	7	6	5	4	3	2	1	0
	—	—	—	—	—	—	—	—	—	—	—	—	—	—	—	—
Initial Value	0	0	0	0	0	0	0	0	0	0	0	0	0	0	0	0
R/W	R	R	R	R	R	R	R	R	R	R	R	R	R	R	R	R

Bit	Bit Name	Initial Value	R/W	Description
31	RFWE	0b	R/W	Reception FIFO Warning interrupt Enable 0b Disabled 1b Enabled While this bit is 1b an interrupt will be generated when RIS1.RFWF is 1b. [Changing condition] This bit is set to 0b when writing 1b to RID1.RFWD. This bit is set to 1b when writing 1b to RIE1.RFWS.
30 to 0	—	All 0	R	Reserved Whenever it is read, 0 is read. The written value will be ignored.

30.4.1.28 Receive Interrupt Enable Register 1 (RIE1)

The RIE register set to 1 each bit in error receive control register (RIC1).

Bit	31	30	29	28	27	26	25	24	23	22	21	20	19	18	17	16
	RFWS	—	—	—	—	—	—	—	—	—	—	—	—	—	—	—
Initial Value	0	0	0	0	0	0	0	0	0	0	0	0	0	0	0	0
R/W	R/W	R	R	R	R	R	R	R	R	R	R	R	R	R	R	R
Bit	15	14	13	12	11	10	9	8	7	6	5	4	3	2	1	0
	—	—	—	—	—	—	—	—	—	—	—	—	—	—	—	—
Initial Value	0	0	0	0	0	0	0	0	0	0	0	0	0	0	0	0
R/W	R	R	R	R	R	R	R	R	R	R	R	R	R	R	R	R

Bit	Bit Name	Initial Value	R/W	Description
31	RFWS	0b	R/W	Reception FIFO Warning interrupt Set 0b No change of RIC1.RFWE 1b Set RIC1.RFWE to 1b This bit supports interrupt enable. It controls set of RIC1.RFWE. This bit is always read as 0b.
30 to 0	—	All 0	R	Reserved Whenever it is read, 0 is read. The written value will be ignored.

30.4.1.29 Receive Interrupt Disable Register 1 (RID1)

The RID1 register set to 1 each bit in receive interrupt control register (RIC1).

Bit	31	30	29	28	27	26	25	24	23	22	21	20	19	18	17	16
	RFWD	—	—	—	—	—	—	—	—	—	—	—	—	—	—	—
Initial Value	0	0	0	0	0	0	0	0	0	0	0	0	0	0	0	0
R/W	R/W	R	R	R	R	R	R	R	R	R	R	R	R	R	R	R
Bit	15	14	13	12	11	10	9	8	7	6	5	4	3	2	1	0
	—	—	—	—	—	—	—	—	—	—	—	—	—	—	—	—
Initial Value	0	0	0	0	0	0	0	0	0	0	0	0	0	0	0	0
R/W	R	R	R	R	R	R	R	R	R	R	R	R	R	R	R	R

Bit	Bit Name	Initial Value	R/W	Description
31	RFWD	0b	R/W	Reception FIFO Warning interrupt Disable 0b No change of RIC1.RFWE 1b Set RIC1.RFWE to 0b This bit supports interrupt enable. It controls set of RIC1.RFWE. This bit is always read as 0b.
30 to 0	—	All 0	R	Reserved Whenever it is read, 0 is read. The written value will be ignored.

30.4.1.30 Receive Interrupt Status Register 2 (RIS2)

The RIS2 register indicates the states of the DMAC receive interrupts.

Bit	31	30	29	28	27	26	25	24	23	22	21	20	19	18	17	16
	RFFF	—	—	—	—	—	—	—	—	—	—	—	—	—	—	—
Initial Value	0	0	0	0	0	0	0	0	0	0	0	0	0	0	0	0
R/W	R/W	R	R	R	R	R	R	R	R	R	R	R	R	R	R	R
Bit	15	14	13	12	11	10	9	8	7	6	5	4	3	2	1	0
	—	—	—	—	—	—	—	—	—	—	—	—	—	—	—	QFF
Initial Value	0	0	0	0	0	0	0	0	0	0	0	0	0	0	0	0
R/W	R	R	R	R	R	R	R	R	R	R	R	R	R	R	R	R/W

Bit	Bit Name	Initial Value	R/W	Description
31	RFFF	0b	R/W	<p>Reception FIFO Full Flag</p> <p>0b No interrupt pending</p> <p>1b Reception FIFO full, received frame data lost</p> <p>This bit indicates that a frame was received by E-MAC which could not be completely stored in the Reception FIFO.</p> <p>The incomplete frame is lost.</p> <p>There is no information available which receive queue would handle this frame.</p> <p>Frames which are marked by E-MAC as faulty after complete reception can also trigger an overrun.</p> <p>The CPU can only write 0b to this bit.</p> <p>[Changing condition]</p> <p>This bit is set to 0b when leaving OPERATION mode.</p> <p>This bit is set to 1b when frame data provided by E-MAC cannot be stored in the Reception FIFO.</p>
30 to 1	—	All 0	R	<p>Reserved</p> <p>Whenever it is read, 0 is read. The written value will be ignored.</p>
0	QFF	0b	R/W	<p>Queue Full Flag</p> <p>0b No interrupt pending</p> <p>1b Queue full, received frame data lost</p> <p>This bit indicates that there was no sufficient space in receive queue to store completely a received frame.</p> <p>A receive queue is treated as full when no empty descriptor (read descriptor with DESCR.DT = FEMPTY or FEMPTY_ND) is available.</p> <p><i>Note:</i> If there is no empty descriptor left in queue during storage of a split frame, an incomplete frame will be stored in the queue. Such incomplete frame can be identified based on a descriptor sequence error (no FEND).</p> <p><i>Note:</i> Reading descriptor may be one or more storage elements ahead from actual storage in URAM. CDARq.CDA provides information where queue has been stopped.</p> <p>The CPU can only write 0b to this bit.</p> <p>[Changing condition]</p> <p>This bit is set to 0b when leaving OPERATION mode.</p> <p>This bit is set to 1b when there is pending receive data in Reception FIFO for receive queue and there is no space left for storage.</p> <p>This bit is set to 1b when a SW defined stop point (EOS descriptor) reached within a split frame.</p>

30.4.1.31 Receive Interrupt Control Register 2 (RIC2)

The RIC2 register controls the DMAC receive interrupts.

Bit	31	30	29	28	27	26	25	24	23	22	21	20	19	18	17	16
	RFFE	—	—	—	—	—	—	—	—	—	—	—	—	—	—	—
Initial Value	0	0	0	0	0	0	0	0	0	0	0	0	0	0	0	0
R/W	R/W	R	R	R	R	R	R	R	R	R	R	R	R	R	R	R
Bit	15	14	13	12	11	10	9	8	7	6	5	4	3	2	1	0
	—	—	—	—	—	—	—	—	—	—	—	—	—	—	—	QFE
Initial Value	0	0	0	0	0	0	0	0	0	0	0	0	0	0	0	0
R/W	R	R	R	R	R	R	R	R	R	R	R	R	R	R	R	R/W

Bit	Bit Name	Initial Value	R/W	Description
31	RFFE	0b	R/W	Reception FIFO Full interrupt Enable 0b Disabled 1b Enabled While this bit is 1b an interrupt will be generated when RIS2.RFFF is 1b. [Changing condition] This bit is set to 0b when writing 1b to RID2.RFFD. This bit is set to 1b when writing 1b to RIE2.RFFS.
30 to 1	—	All 0	R	Reserved Whenever it is read, 0 is read. The written value will be ignored.
0	QFE	0b	R/W	Queue Full interrupt Enable 0b Disabled 1b Enabled While this bit is 1b an interrupt will be generated when RIS2.QFF is 1b. [Changing condition] This bit is set to 0b when writing 1b to RID2.QFD. This bit is set to 1b when writing 1b to RIE2.QFS.

30.4.1.32 Receive Interrupt Enable Register 2 (RIE2)

The RIE2 register set to 1 each bit in receive interrupt control register (RIC2).

Bit	31	30	29	28	27	26	25	24	23	22	21	20	19	18	17	16
	RFFS	—	—	—	—	—	—	—	—	—	—	—	—	—	—	—
Initial Value	0	0	0	0	0	0	0	0	0	0	0	0	0	0	0	0
R/W	R/W	R	R	R	R	R	R	R	R	R	R	R	R	R	R	R
Bit	15	14	13	12	11	10	9	8	7	6	5	4	3	2	1	0
	—	—	—	—	—	—	—	—	—	—	—	—	—	—	—	QFS
Initial Value	0	0	0	0	0	0	0	0	0	0	0	0	0	0	0	0
R/W	R	R	R	R	R	R	R	R	R	R	R	R	R	R	R	R/W

Bit	Bit Name	Initial Value	R/W	Description
31	RFFS	0b	R/W	Reception FIFO Full interrupt Set 0b No change of RIC2.RFFE 1b Set RIC2.RFFE to 1b This bit supports interrupt enable. It controls set of RIC2.RFFE. This bit is always read as 0b.
30 to 1	—	All 0	R	Reserved Whenever it is read, 0 is read. The written value will be ignored.
0	QFS	0b	R/W	Queue Full interrupt Set 0b No change of RIC2.QFE 1b Set RIC2.QFE to 1b This bit supports interrupt enable. It controls set of RIC2.QFE. This bit is always read as 0b.

30.4.1.33 Receive Interrupt Disable Register 2 (RID2)

The RID2 register set to 1 each bit in receive interrupt control register (RIC2).

Bit	31	30	29	28	27	26	25	24	23	22	21	20	19	18	17	16
	RFFD	—	—	—	—	—	—	—	—	—	—	—	—	—	—	—
Initial Value	0	0	0	0	0	0	0	0	0	0	0	0	0	0	0	0
R/W	R/W	R	R	R	R	R	R	R	R	R	R	R	R	R	R	R
Bit	15	14	13	12	11	10	9	8	7	6	5	4	3	2	1	0
	—	—	—	—	—	—	—	—	—	—	—	—	—	—	—	QFD
Initial Value	0	0	0	0	0	0	0	0	0	0	0	0	0	0	0	0
R/W	R	R	R	R	R	R	R	R	R	R	R	R	R	R	R	R/W

Bit	Bit Name	Initial Value	R/W	Description
31	RFFD	0b	R/W	Reception FIFO Full interrupt Disable 0b No change of RIC2.RFFE 1b Set RIC2.RFFE to 0b This bit supports interrupt enable. It controls set of RIC2.RFFE. This bit is always read as 0b.
30 to 1	—	All 0	R	Reserved Whenever it is read, 0 is read. The written value will be ignored.
0	QFD	0b	R/W	Queue Full interrupt Disable 0b No change of RIC2.QFE 1b Set RIC2.QFE to 0b This bit supports interrupt enable. It controls set of RIC2.QFE. This bit is always read as 0b.

30.4.1.34 Receive Interrupt Status Register 3 (RIS3)

The RIS3 register indicates the states of the DMAC receive interrupts.

Bit	31	30	29	28	27	26	25	24	23	22	21	20	19	18	17	16
	—	—	—	—	—	—	—	—	—	—	—	—	—	—	—	—
Initial Value	0	0	0	0	0	0	0	0	0	0	0	0	0	0	0	0
R/W	R	R	R	R	R	R	R	R	R	R	R	R	R	R	R	R
Bit	15	14	13	12	11	10	9	8	7	6	5	4	3	2	1	0
	—	—	—	—	—	—	—	—	—	—	—	—	—	—	—	RDPF
Initial Value	0	0	0	0	0	0	0	0	0	0	0	0	0	0	0	0
R/W	R	R	R	R	R	R	R	R	R	R	R	R	R	R	R	R/W

Bit	Bit Name	Initial Value	R/W	Description
31 to 1	—	All 0	R	Reserved Whenever it is read, 0 is read. The written value will be ignored.
0	RDPF	0b	R/W	<p>Receive Descriptor Processed Flag</p> <p>0b No interrupt pending 1b Descriptor interrupt pending</p> <p>This bit indicates that a descriptor in reception queue has been processed where DESC.R.DIE is 0001b.</p> <p><i>Note:</i> The descriptor with DESC.R.DIE is 1, which sets this bit, sets in addition the universal descriptor interrupt DIS.DPF1.</p> <p>The CPU can only write 0b to this bit.</p> <p>[Changing condition]</p> <p>This bit is set to 0b when leaving OPERATION mode.</p> <p>This bit is set to 1b when a descriptor in reception queue has been processed where DESC.R.DIE is 1.</p>

30.4.1.35 Receive Interrupt Control Register 3 (RIC3)

The RIC3 register controls the DMAC receive interrupts.

Bit	31	30	29	28	27	26	25	24	23	22	21	20	19	18	17	16
	—	—	—	—	—	—	—	—	—	—	—	—	—	—	—	—
Initial Value	0	0	0	0	0	0	0	0	0	0	0	0	0	0	0	0
R/W	R	R	R	R	R	R	R	R	R	R	R	R	R	R	R	R
Bit	15	14	13	12	11	10	9	8	7	6	5	4	3	2	1	0
	—	—	—	—	—	—	—	—	—	—	—	—	—	—	—	RDPE
Initial Value	0	0	0	0	0	0	0	0	0	0	0	0	0	0	0	0
R/W	R	R	R	R	R	R	R	R	R	R	R	R	R	R	R	R/W

Bit	Bit Name	Initial Value	R/W	Description
31 to 1	—	All 0	R	Reserved Whenever it is read, 0 is read. The written value will be ignored.
0	RDPE	0b	R/W	Receive Descriptor Processed interrupt Enable 0b Disabled 1b Enabled While this bit is 1b an interrupt will be generated when RIS3.RDPF is 1b. [Changing condition] This bit is set to 0b when writing 1b to RID3.RDPD. This bit is set to 1b when writing 1b to RIE3.RDPS.

30.4.1.36 Receive Interrupt Enable Register 3 (RIE3)

The RIE3 register set to 1 each bit in receive interrupt control register (RIC3).

Bit	31	30	29	28	27	26	25	24	23	22	21	20	19	18	17	16
	—	—	—	—	—	—	—	—	—	—	—	—	—	—	—	—
Initial Value	0	0	0	0	0	0	0	0	0	0	0	0	0	0	0	0
R/W	R	R	R	R	R	R	R	R	R	R	R	R	R	R	R	R
Bit	15	14	13	12	11	10	9	8	7	6	5	4	3	2	1	0
	—	—	—	—	—	—	—	—	—	—	—	—	—	—	—	RDPS
Initial Value	0	0	0	0	0	0	0	0	0	0	0	0	0	0	0	0
R/W	R	R	R	R	R	R	R	R	R	R	R	R	R	R	R	R/W

Bit	Bit Name	Initial Value	R/W	Description
31 to 1	—	All 0	R	Reserved Whenever it is read, 0 is read. The written value will be ignored.
0	RDPS	0b	R/W	Receive Descriptor Processed interrupt Set 0b No change of RIC3.RDPE 1b Set RIC3.RDPE to 1b This bit supports interrupt enable. It controls set of RIC3.RDPE. This bit is always read as 0b.

30.4.1.37 Receive Interrupt Disable Register 3 (RID3)

The RID3 register set to 0 each bit in receive interrupt control register (RIC3).

Bit	31	30	29	28	27	26	25	24	23	22	21	20	19	18	17	16
	—	—	—	—	—	—	—	—	—	—	—	—	—	—	—	—
Initial Value	0	0	0	0	0	0	0	0	0	0	0	0	0	0	0	0
R/W	R	R	R	R	R	R	R	R	R	R	R	R	R	R	R	R
Bit	15	14	13	12	11	10	9	8	7	6	5	4	3	2	1	0
	—	—	—	—	—	—	—	—	—	—	—	—	—	—	—	RDPD
Initial Value	0	0	0	0	0	0	0	0	0	0	0	0	0	0	0	0
R/W	R	R	R	R	R	R	R	R	R	R	R	R	R	R	R	R/W

Bit	Bit Name	Initial Value	R/W	Description
31 to 1	—	All 0	R	Reserved Whenever it is read, 0 is read. The written value will be ignored.
0	RDPD	0b	R/W	Receive Descriptor Processed interrupt Disable 0b No change of RIC3.RDPE 1b Set RIC3.RDPE to 0b This bit supports interrupt enable. It controls set of RIC3.RDPE. This bit is always read as 0b.

30.4.1.38 Transmit Interrupt Status Register (TIS)

The TIS register indicates the states of the DMAC transmit interrupts.

Bit	31	30	29	28	27	26	25	24	23	22	21	20	19	18	17	16
	—	—	—	—	—	—	—	—	—	—	—	—	—	—	—	TDPF
Initial Value	0	0	0	0	0	0	0	0	0	0	0	0	0	0	0	0
R/W	R	R	R	R	R	R	R	R	R	R	R	R	R	R	R	R/W
Bit	15	14	13	12	11	10	9	8	7	6	5	4	3	2	1	0
	—	RCSRFB	MFWF2	MFWF2	MFWF	MFWF	—	—	—	—	—	—	—	—	—	FTF
Initial Value	0	0	0	0	0	0	0	0	0	0	0	0	0	0	0	0
R/W	R	R/W	R/W	R/W	R/W	R/W	R	R	R	R	R	R	R	R	R	R/W

Bit	Bit Name	Initial Value	R/W	Description
31 to 17	—	All 0	R	Reserved Whenever it is read, 0 is read. The written value will be ignored.
16	TDPF	0b	R/W	Transmit Descriptor Processed Flag 0b No interrupt pending 1b Descriptor interrupt pending This bit indicates that a descriptor in transmit queue has been processed where DESC.R.DIE is 0001b. <i>Note:</i> The descriptor with DESC.R.DIE is 1, which sets this bit, sets in addition the universal descriptor interrupt DIS.DPF1. The CPU can only write 0b to this bit. [Changing condition] This bit is set to 0b when leaving OPERATION mode. This bit is set to 1b when a descriptor in transmit queue has been processed where DESC.R.DIE is 1.
15	—	0b	R	Reserved Whenever it is read, 0 is read. The written value will be ignored.
14	RCSRFB	0b	R/W	Reference Clock Stop Req Flag 0b No interrupt pending 1b Reference Clock Stop Request occurred This bit indicates that Gigabit Ethernet Interface expects to stop "clk_miitx_gtx_refclk". Whenever this flag is asserted, CPU has to stop ETH_PLL (PLL to generate "clk_miitx_gtx_refclk"). To stop ETH_PLL, refer to the document of System Controller. The CPU can only write 0b to this bit. [Changing condition] This bit is set to 0b when leaving OPERATION mode. This bit is set to 0b when CCC.ERCS is 0b. This bit is set to 1b when Gigabit Ethernet Interface has expected to stop "clk_miitx_gtx_refclk".

Bit	Bit Name	Initial Value	R/W	Description
13	MFWF2	0b	R/W	<p>MAC status FIFO2 Warning Flag</p> <p>0b No interrupt pending</p> <p>1b Tx Status FIFO2 warning level has been reached</p> <p>This bit indicates that the warning level of the MAC status FIFO2 (12 out of 16 entries) has been reached.</p> <p>The CPU can only write 0b to this bit.</p> <p>[Changing condition]</p> <p>This bit is set to 0b when leaving OPERATION mode.</p> <p>This bit is set to 0b when TCCR.MFEN2 is 0b.</p> <p>This bit is set to 0b when writing 1b to TCCR.MFR2.</p> <p>This bit is set to 1b when TCCR.MFEN2 is 1b, the MAC Status FIFO2 contains already 11 entries (TSR.MFFL2 is 11), and E-MAC detects an error during transmission of frame.</p>
12	MFUF2	0b	R/W	<p>MAC status FIFO2 Updated Flag</p> <p>0b No interrupt pending</p> <p>1b Tx Status FIFO2 has been updated</p> <p>This bit indicates that the MAC status FIFO2 has been updated when the E-MAC detects an error during transmission of frame.</p> <p>The CPU can only write 0b to this bit.</p> <p>[Changing condition]</p> <p>This bit is set to 0b when leaving OPERATION mode.</p> <p>This bit is set to 0b when TCCR.MFEN2 is 0b.</p> <p>This bit is set to 0b when writing 1b to TCCR.MFR2.</p> <p>This bit is set to 1b when TCCR.MFEN2 is 1b and E-MAC detects an error during transmission of frame.</p>
11	MFWF	0b	R/W	<p>MAC status FIFO Warning Flag</p> <p>0b No interrupt pending</p> <p>1b Tx Status FIFO warning level has been reached</p> <p>This bit indicates that the warning level of the MAC status FIFO (12 out of 16 entries) has been reached.</p> <p>The CPU can only write 0b to this bit.</p> <p>[Changing condition]</p> <p>This bit is set to 0b when leaving OPERATION mode.</p> <p>This bit is set to 0b when TCCR.MFEN is 0b.</p> <p>This bit is set to 0b when writing 1b to TCCR.MFR.</p> <p>This bit is set to 1b when frame with DESCR.MSR has been transmitted to TOE, TCCR.MFEN is 1b and the MAC Status FIFO contains already 11 entries (TSR.MFFL is 11).</p>
10	MFUF	0b	R/W	<p>MAC status FIFO Updated Flag</p> <p>0b No interrupt pending</p> <p>1b Tx Status FIFO has been updated</p> <p>This bit indicates that the MAC status FIFO has been updated after the TOE has transmitted a frame.</p> <p>The CPU can only write 0b to this bit.</p> <p>[Changing condition]</p> <p>This bit is set to 0b when leaving OPERATION mode.</p> <p>This bit is set to 0b when TCCR.MFEN is 0b.</p> <p>This bit is set to 0b when writing 1b to TCCR.MFR.</p> <p>This bit is set to 1b when frame with DESCR.MSR has been transmitted to TOE and TCCR.MFEN is 1b.</p>
9 to 1	—	All 0	R	<p>Reserved</p> <p>Whenever it is read, 0 is read. The written value will be ignored.</p>

Bit	Bit Name	Initial Value	R/W	Description
0	FTF	0b	R/W	Frame Transmitted Flag 0b No interrupt pending 1b Frame transmitted by E-MAC This bit indicates that from transmit queue a frame is transmitted from DMAC. The CPU can only write 0b to this bit. [Changing condition] This bit is set to 0b when leaving OPERATION mode. This bit is set to 1b when a frame from transmit queue has been transmitted from DMAC.

30.4.1.39 Transmit Interrupt Control Register (TIC)

The TIC register controls the DMAC transmit interrupts.

Bit	31	30	29	28	27	26	25	24	23	22	21	20	19	18	17	16
	—	—	—	—	—	—	—	—	—	—	—	—	—	—	—	TDPE
Initial Value	0	0	0	0	0	0	0	0	0	0	0	0	0	0	0	0
R/W	R	R	R	R	R	R	R	R	R	R	R	R	R	R	R	R/W
Bit	15	14	13	12	11	10	9	8	7	6	5	4	3	2	1	0
	—	RCSRE	MFWE2	MFUE2	MFWE	MFUE	—	—	—	—	—	—	—	—	—	FTE
Initial Value	0	0	0	0	0	0	0	0	0	0	0	0	0	0	0	0
R/W	R	R/W	R/W	R/W	R/W	R/W	R	R	R	R	R	R	R	R	R	R/W

Bit	Bit Name	Initial Value	R/W	Description
31 to 17	—	All 0	R	Reserved Whenever it is read, 0 is read. The written value will be ignored.
16	TDPE	0b	R/W	Transmit Descriptor Processed interrupt Enable 0b Disabled 1b Enabled While this bit is 1b an interrupt will be generated when TIS.TDPF is 1b. [Changing condition] This bit is set to 0b when writing 1b to TID.TDPD. This bit is set to 1b when writing 1b to TIE.TDPS.
15	—	0b	R	Reserved Whenever it is read, 0 is read. The written value will be ignored.
14	RCSRE	0b	R/W	Reference Clock Stop Req interrupt Enable 0b Disabled 1b Enabled While this bit is 1b an interrupt will be generated when TIS.RCSRF is 1b. [Changing condition] This bit is set to 0b when writing 1b to TID.RCSR.D. This bit is set to 1b when writing 1b to TIE.RCSRS.
13	MFWE2	0b	R/W	MAC status FIFO2 Warning interrupt Enable 0b Disabled 1b Enabled While this bit is 1b an interrupt will be generated when TIS.MFWF2 is 1b. [Changing condition] This bit is set to 0b when writing 1b to TID.MFWD2. This bit is set to 1b when writing 1b to TIE.MFWS2.
12	MFUE2	0b	R/W	MAC status FIFO2 Updated interrupt Enable 0b Disabled 1b Enabled While this bit is 1b an interrupt will be generated when TIS.MFUF2 is 1b. [Changing condition] This bit is set to 0b when writing 1b to TID.MFUD2. This bit is set to 1b when writing 1b to TIE.MFUS2.

Bit	Bit Name	Initial Value	R/W	Description
11	MFWE	0b	R/W	<p>MAC status FIFO Warning interrupt Enable</p> <p>0b Disabled</p> <p>1b Enabled</p> <p>While this bit is 1b an interrupt will be generated when TIS.MFWF is 1b. [Changing condition]</p> <p>This bit is set to 0b when writing 1b to TID.MFWD.</p> <p>This bit is set to 1b when writing 1b to TIE.MFWS.</p>
10	MFUE	0b	R/W	<p>MAC status FIFO Updated interrupt Enable</p> <p>0b Disabled</p> <p>1b Enabled</p> <p>While this bit is 1b an interrupt will be generated when TIS.MFUF is 1b. [Changing condition]</p> <p>This bit is set to 0b when writing 1b to TID.MFUD.</p> <p>This bit is set to 1b when writing 1b to TIE.MFUS.</p>
9 to 1	—	All 0	R	<p>Reserved</p> <p>Whenever it is read, 0 is read. The written value will be ignored.</p>
0	FTE	0b	R/W	<p>Frame Transmitted interrupt Enable</p> <p>0b Disabled</p> <p>1b Enabled</p> <p>While this bit is 1b an interrupt will be generated when TIS.FTF is 1b. [Changing condition]</p> <p>This bit is set to 0b when writing 1b to TID.FTD.</p> <p>This bit is set to 1b when writing 1b to TIE.FTS.</p>

30.4.1.40 Transmit Interrupt Enable Register (TIE)

The TIE register set to 1 each bit in transmit interrupt control register (TIC).

Bit	31	30	29	28	27	26	25	24	23	22	21	20	19	18	17	16
	—	—	—	—	—	—	—	—	—	—	—	—	—	—	—	TDPS
Initial Value	0	0	0	0	0	0	0	0	0	0	0	0	0	0	0	0
R/W	R	R	R	R	R	R	R	R	R	R	R	R	R	R	R	R/W
Bit	15	14	13	12	11	10	9	8	7	6	5	4	3	2	1	0
	—	RCSRS	MFWS2	MFUS2	MFWS	MFUS	—	—	—	—	—	—	—	—	—	FTS
Initial Value	0	0	0	0	0	0	0	0	0	0	0	0	0	0	0	0
R/W	R	R/W	R/W	R/W	R/W	R/W	R	R	R	R	R	R	R	R	R	R/W

Bit	Bit Name	Initial Value	R/W	Description
31 to 17	—	All 0	R	Reserved Whenever it is read, 0 is read. The written value will be ignored.
16	TDPS	0b	R/W	Transmit Descriptor Processed interrupt Set 0b No change of TIC.TDPE 1b Set TIC.TDPE to 1b This bit supports interrupt enable. It controls set of TIC.TDPE. This bit is always read as 0b.
15	—	0b	R	Reserved Whenever it is read, 0 is read. The written value will be ignored.
14	RCSRS	0b	R/W	Reference Clock Stop Req interrupt Set 0b No change of TIC.RCSRE 1b Set TIC.RCSRE to 1b This bit supports interrupt enable. It controls set of TIC.RCSRE. This bit is always read as 0b.
13	MFWS2	0b	R/W	MAC status FIFO2 Warning interrupt Set 0b No change of TIC.MFWE2 1b Set TIC.MFWE2 to 1b This bit supports interrupt enable. It controls set of TIC.MFWE2. This bit is always read as 0b.
12	MFUS2	0b	R/W	MAC status FIFO2 Updated interrupt Set 0b No change of TIC.MFUE2 1b Set TIC.MFUE2 to 1b This bit supports interrupt enable. It controls set of TIC.MFUE2. This bit is always read as 0b.
11	MFWS	0b	R/W	MAC status FIFO Warning interrupt Set 0b No change of TIC.MFWE 1b Set TIC.MFWE to 1b This bit supports interrupt enable. It controls set of TIC.MFWE. This bit is always read as 0b.
10	MFUS	0b	R/W	MAC status FIFO Updated interrupt Set 0b No change of TIC.MFUE 1b Set TIC.MFUE to 1b This bit supports interrupt enable. It controls set of TIC.MFUE. This bit is always read as 0b.
9 to 1	—	All 0	R	Reserved Whenever it is read, 0 is read. The written value will be ignored.

Bit	Bit Name	Initial Value	R/W	Description
0	FTS	0b	R/W	Frame Transmitted interrupt Set 0b No change of TIC.FTE 1b Set TIC.FTE to 1b This bit supports interrupt enable. It controls set of TIC.FTE. This bit is always read as 0b.

30.4.1.41 Transmit Interrupt Disable Register (TID)

The TID register set to 0 each bit in transmit interrupt control register (TIC).

Bit	31	30	29	28	27	26	25	24	23	22	21	20	19	18	17	16
	—	—	—	—	—	—	—	—	—	—	—	—	—	—	—	TDPD
Initial Value	0	0	0	0	0	0	0	0	0	0	0	0	0	0	0	0
R/W	R	R	R	R	R	R	R	R	R	R	R	R	R	R	R	R/W
Bit	15	14	13	12	11	10	9	8	7	6	5	4	3	2	1	0
	—	RCSR	MFWD2	MFUD2	MFWD	MFUD	—	—	—	—	—	—	—	—	—	FTD
Initial Value	0	0	0	0	0	0	0	0	0	0	0	0	0	0	0	0
R/W	R	R/W	R/W	R/W	R/W	R/W	R	R	R	R	R	R	R	R	R	R/W

Bit	Bit Name	Initial Value	R/W	Description
31 to 17	—	All 0	R	Reserved Whenever it is read, 0 is read. The written value will be ignored.
16	TDPD	0b	R/W	Transmit Descriptor Processed interrupt Disable 0b No change of TIC.TDPE 1b Set TIC.TDPE to 0b This bit supports interrupt enable. It controls set of TIC.TDPE. This bit is always read as 0b.
15	—	0b	R	Reserved Whenever it is read, 0 is read. The written value will be ignored.
14	RCSR	0b	R/W	Reference Clock Stop Req interrupt Disable 0b No change of TIC.RCSRE 1b Set TIC.RCSRE to 0b This bit supports interrupt enable. It controls set of TIC.RCSRE. This bit is always read as 0b.
13	MFWD2	0b	R/W	MAC status FIFO2 Warning interrupt Disable 0b No change of TIC.MFWE2 1b Set TIC.MFWE2 to 0b This bit supports interrupt enable. It controls set of TIC.MFWE2. This bit is always read as 0b.
12	MFUD2	0b	R/W	MAC status FIFO2 Updated interrupt Disable 0b No change of TIC.MFUE2 1b Set TIC.MFUE2 to 0b This bit supports interrupt enable. It controls set of TIC.MFUE2. This bit is always read as 0b.
11	MFWD	0b	R/W	MAC status FIFO Warning interrupt Disable 0b No change of TIC.MFWE 1b Set TIC.MFWE to 0b This bit supports interrupt enable. It controls set of TIC.MFWE. This bit is always read as 0b.
10	MFUD	0b	R/W	MAC status FIFO Updated interrupt Disable 0b No change of TIC.MFUE 1b Set TIC.MFUE to 0b This bit supports interrupt enable. It controls set of TIC.MFUE. This bit is always read as 0b.
9 to 1	—	All 0	R	Reserved Whenever it is read, 0 is read. The written value will be ignored.

Bit	Bit Name	Initial Value	R/W	Description
0	FTD	0b	R/W	Frame Transmitted interrupt Disable 0b No change of TIC.FTE 1b Set TIC.FTE to 0b This bit supports interrupt enable. It controls set of TIC.FTE. This bit is always read as 0b.

30.4.1.42 Common Interrupt Enable register (CIE)

The CIE register is used to control interrupts line.

Bit	31	30	29	28	27	26	25	24	23	22	21	20	19	18	17	16
	—	—	—	—	—	—	—	—	—	—	—	—	—	—	—	—
Initial Value	0	0	0	0	0	0	0	0	0	0	0	0	0	0	0	0
R/W	R	R	R	R	R	R	R	R	R	R	R	R	R	R	R	R
Bit	15	14	13	12	11	10	9	8	7	6	5	4	3	2	1	0
	—	—	—	—	—	—	—	CTIE	—	—	—	—	—	—	—	CRIE
Initial Value	0	0	0	0	0	0	0	0	0	0	0	0	0	0	0	0
R/W	R	R	R	R	R	R	R	R/W	R	R	R	R	R	R	R	R/W

Bit	Bit Name	Initial Value	R/W	Description
31 to 9	—	All 0	R	Reserved Whenever it is read, 0 is read. The written value will be ignored.
8	CTIE	0b	R/W	Common Transmit Interrupt Enable 0b Disabled 1b Enabled This bit controls transmit related interrupt outputs of Gigabit Ethernet Interface. It has no influence on internal flagging in Gigabit Ethernet Interface SFR (e.g. ISS).
7 to 1	—	All 0	R	Reserved Whenever it is read, 0 is read. The written value will be ignored.
0	CRIE	0b	R/W	Common Receive Interrupt Enable 0b Disabled 1b Enabled This bit controls receive related interrupt outputs of Gigabit Ethernet Interface. It has no influence on internal flagging in Gigabit Ethernet Interface SFR (e.g. ISS).

30.4.1.43 Interrupt Summary Status Register (ISS)

The ISS register gives a summary of the states of DMAC-related interrupts.

Bit	31	30	29	28	27	26	25	24	23	22	21	20	19	18	17	16
	DPM15	DPM14	DPM13	DPM12	DPM11	DPM10	DPM9	DPM8	DPM7	DPM6	DPM5	DPM4	DPM3	DPM2	DPM1	RCSRm
Initial Value	0	0	0	0	0	0	0	0	0	0	0	0	0	0	0	0
R/W	R	R	R	R	R	R	R	R	R	R	R	R	R	R	R	R
Bit	15	14	13	12	11	10	9	8	7	6	5	4	3	2	1	0
	MFWM2	MFUM2	—	RFWM	MFWM	MFUM	—	—	MM	EM	—	—	—	FTM	—	FRM
Initial Value	0	0	0	0	0	0	0	0	0	0	0	0	0	0	0	0
R/W	R	R	R	R	R	R	R	R	R	R	R	R	R	R	R	R

Bit	Bit Name	Initial Value	R/W	Description
31 to 17	DPMi	All 0	R	Descriptor Processed Mirror i 0b No interrupt pending 1b Descriptor interrupt pending Descriptor Processed Mirror i (i = 1 to 15) [Changing condition] This bit is set when any matching pair of DIC.DPEi enable and DIS.DPFi flag are both 1b.
16	RCSRm	0b	R	Reference Clock Stop Req Mirror 0b No interrupt pending 1b Reference Clock Stop Req interrupt pending This bit indicates that TIS.RCSRf is 1b and TIC.RCSRE is 1b. [Changing condition] This bit is updated when TIS.RCSRf or TIC.RCSRE changes.
15	MFWM2	0b	R	MAC status FIFO2 Warning Mirror 0b No interrupt pending 1b MAC status FIFO2 warning interrupt pending This bit indicates that TIS.MFWF2 is 1b and TIC.MFWE2 is 1b. [Changing condition] This bit is updated when TIS.MFWF2 or TIC.MFWE2 changes.
14	MFUM2	0b	R	MAC status FIFO2 Updated Mirror 0b No interrupt pending 1b MAC status FIFO2 updated interrupt pending This bit indicates that TIS.MFUF2 is 1b and TIC.MFUE2 is 1b. [Changing condition] This bit is updated when TIS.MFUF2 or TIC.MFUE2 changes.
13	—	0b	R	Reserved Whenever it is read, 0 is read. The written value will be ignored.
12	RFWM	0b	R	Reception FIFO Warning Summary 0b No interrupt pending 1b Reception FIFO warning interrupt pending This bit indicates that RIS1.RFWF is 1b and RIC1.RFWE is 1b. [Changing condition] This bit is updated when RIS1.RFWF or RIC1.RFWE changes.

Bit	Bit Name	Initial Value	R/W	Description
11	MFWM	0b	R	<p>MAC status FIFO Warning Mirror</p> <p>0b No interrupt pending 1b MAC status FIFO warning interrupt pending</p> <p>This bit indicates that TIS.MFWF is 1b and TIC.MFWE is 1b. [Changing condition]</p> <p>This bit is updated when TIS.MFWF or TIC.MFWE changes.</p>
10	MFUM	0b	R	<p>MAC status FIFO Updated Mirror</p> <p>0b No interrupt pending 1b MAC status FIFO updated interrupt pending</p> <p>This bit indicates that TIS.MFUF is 1b and TIC.MFUE is 1b. [Changing condition]</p> <p>This bit is updated when TIS.MFUF or TIC.MFUE changes.</p>
9 to 8	—	All 0	R	<p>Reserved</p> <p>Whenever it is read, 0 is read. The written value will be ignored.</p>
7	MM	0b	R	<p>MAC Mirror</p> <p>0b No interrupt pending 1b MAC interrupt pending</p> <p>This bit indicates that there is a pending interrupt request issued by MAC.</p> <p><i>Note:</i> The MAC is able to assert interrupt also in CONFIG mode.</p>
6	EM	0b	R	<p>Error Mirror</p> <p>0b No interrupt pending 1b Error interrupt pending</p> <p>This bit indicates that at least one enabled flag in EIS is 1b or EIS.QFS is 1b. [Changing condition]</p> <p>This bit is updated when EIS or EIC changes.</p>
5 to 3	—	All 0	R	<p>Reserved</p> <p>Whenever it is read, 0 is read. The written value will be ignored.</p>
2	FTM	0b	R	<p>Frame Transmitted Mirror</p> <p>0b No interrupt pending 1b Frame transmitted interrupt pending</p> <p>[Changing condition]</p> <p>This bit is set when any matching pair of TIC.FTE enable and TIS.FTF flag are both 1b. This bit is set when any matching pair of TIC.TDPE enable and TIS.TDPF flag are both 1b.</p>
1	—	0b	R	<p>Reserved</p> <p>Whenever it is read, 0 is read. The written value will be ignored.</p>
0	FRM	0b	R	<p>Frame Received Mirror</p> <p>0b No interrupt pending 1b Frame received interrupt pending</p> <p>[Changing condition]</p> <p>This bit is set when any matching pair of RIC0.FRE enable and RIS0.FRF flag are both 1b. This bit is set when any matching pair of RIC3.RDPE enable and RIS3.RDPF flag are both 1b.</p>

30.4.2 E-MAC Registers

30.4.2.1 E-MAC operating mode register 1 (CXR20)

CXR20 sets the E-MAC operating mode.

Rewriting the bits in this register is prohibited when the transmission function is enabled (TPE=1) and reception function is enabled (RPE=1).

Write restrictions:

Rewrite all the bits except for TPE and RPE when transmission function is disabled (TPE=0) and reception function is disabled (RPE=0).

Bit	31	30	29	28	27	26	25	24	23	22	21	20	19	18	17	16
	—	—	—	—	—	TRCCM	RCPT	TCPT	RCSC	CXSER	DPAD	RZPF	TZPF	PFR	RXF	TXF
Initial Value	0	0	0	0	0	0	0	0	0	0	0	0	0	0	0	0
R/W	R	R	R	R	R	R/W	R/W	R/W	R/W	R/W	R/W	R/W	R/W	R/W	R/W	R/W

Bit	15	14	13	12	11	10	9	8	7	6	5	4	3	2	1	0
	—	—	—	CER	—	—	—	—	—	RPE	TPE	LPM	—	—	DPM	PRM
Initial Value	0	0	0	0	0	0	0	0	0	0	0	0	0	0	0	0
R/W	R	R	R	R/W	R	R	R	R	R	R/W	R/W	R/W	R	R	R/W	R/W

Bit	Bit Name	Initial Value	R/W	Description
31 to 27	—	All 0	R	Reserved Whenever it is read, 0 is read. The written value will be ignored.
26	TRCCM	0b	R/W	TINT/RINT Counter Clear Mode Specifies the method of clearing TINT source counter (CXR40-43) and RINT source counter (CXR50-57). 1: Clears the register to 0 when reading the register. 0: Clears the register to 0 when writing to the register. (clears any write data to 0 at write)
25	RCPT	0b	R/W	Reception CRC Pass Through 1: CRC of received frame is transferred to TOE. RCSC (auto calculation of checksum of received frame data part) function is disabled at this time. 0: CRC of received frame is not transferred to TOE.
24	TCPT	0b	R/W	Transmit CRC Pass Through 1: CRC of transmit frame is not calculated automatically (hardware calculation). It is necessary to input the data with CRC added in AT port. 0: CRC of transmit frame is calculated automatically (hardware calculation). It is necessary to input the data without CRC added in AT port.
23	RCSC	0b	R/W	Reception Check Sum Calculation 1: Checksum of received frame data part is automatically calculated (hardware calculation). RCPT must be set to 0 at this time. 0: Checksum of received frame data part is not calculated automatically (hardware calculation).
22	CXSER	0b	R/W	Carrier extension Short Error Function for debug. It should always be set to 0.

Bit	Bit Name	Initial Value	R/W	Description
21	DPAD	0b	R/W	Data Padding 1: Less than 60-byte data is transmitted without padding. 0: Less than 60-byte data is padded and transmitted as 60-byte data.
20	RZPF	0b	R/W	Reception Zero PAUSE Frame 1: Enables to receive PAUSE frame with TIME parameter value being 0. 0: Disables receiving PAUSE frame with TIME parameter value being 0.
19	TZPF	0b	R/W	Transmit Zero PAUSE Frame 1: PAUSE frame of 0 Time parameter value is transmitted at asserting "Reception FIFO Critical Level Notification" from DMAC 0: PAUSE frame of 0 Time parameter value is not transmitted at asserting "Reception FIFO Critical Level Notification" from DMAC
18	PFR	0b	R/W	PAUSE Frame Receive 1: PAUSE frame is transferred to TOE. 0: PAUSE frame is not transferred to TOE.
17	RXF	0b	R/W	Receive Flow control mode 1: Receive flow control function (PAUSE frame reception) is enabled. 0: Receive flow control function (PAUSE frame reception) is disabled.
16	TXF	0b	R/W	Transmit Flow control mode 1: Transmit flow control function (PAUSE frame transmission) is enabled. 0: Transmit flow control function (PAUSE frame transmission) is disabled.
15 to 13	—	All 0	R	Reserved Whenever it is read, 0 is read. The written value will be ignored.
12	CER	0b	R/W	CRC Error Used for debugging. It should always be set to 0.
11 to 10	—	All 0	R	Reserved Whenever it is read, 0 is read. The written value will be ignored.
9	—	0b	R	Reserved When read, the initial value is read. When writing, be sure to write the initial value. Operation is not guaranteed if a value other than the initial value is written.
8 to 7	—	All 0	R	Reserved Whenever it is read, 0 is read. The written value will be ignored.
6	RPE	0b	R/W	Receive Port Enable 1: Receive function of E-MAC is enabled. 0: Receive function of E-MAC is disabled. If 1 is changed to 0 while a frame is being received, the frame is completely received.
5	TPE	0b	R/W	Transmit Port Enable 1: Transmission function of E-MAC is enabled. 0: Transmission function of E-MAC is disabled. If 1 is changed to 0 while a frame is being transmitted, the frame is completely transmitted.
4	LPM	0b	R/W	Low Power Mode 1: E-MAC operates as Low Power Mode. 0: E-MAC operates as Normal Mode. (When LPM bit is set to "1", DPM bit should be also set to "1")
3 to 2	—	All 0	R	Reserved Whenever it is read, 0 is read. The written value will be ignored.
1	DPM	0b	R/W	Duplex Mode 1: Operates in full duplex mode. 0: Operates in half duplex mode.

Bit	Bit Name	Initial Value	R/W	Description
0	PRM	0b	R/W	Promiscuous Mode 1: All the frames except for PAUSE frame are received. Self-addressed unicast, different address unicast, multicast, and broadcast frames are all transferred to TOE. PAUSE frame reception is controlled by PFR bit. 0: Self-addressed unicast, multicast, and broadcast frames are received, then transferred to TOE.

30.4.2.2 Maximum receive frame length register (CXR2A)

CXR2A sets the maximum receive frame length.

Write restrictions:

If CXR20_bit6 is set to 1, it is not allowed to rewrite to this register.

Bit	31	30	29	28	27	26	25	24	23	22	21	20	19	18	17	16
	LEN_LMT[17:16]															
Initial Value	0	0	0	0	0	0	0	0	0	0	0	0	0	0	0	0
R/W	R	R	R	R	R	R	R	R	R	R	R	R	R	R	R/W	R/W
Bit	15	14	13	12	11	10	9	8	7	6	5	4	3	2	1	0
	LEN_LMT[15:0]															
Initial Value	0	0	0	0	0	0	0	0	0	0	0	0	0	0	0	0
R/W	R/W	R/W	R/W	R/W	R/W	R/W	R/W	R/W	R/W	R/W	R/W	R/W	R/W	R/W	R/W	R/W

Bit	Bit Name	Initial Value	R/W	Description																										
31 to 18	—	All 0	R	Reserved Whenever it is read, 0 is read. The written value will be ignored.																										
17 to 0	LEN_LMT	H'000	R/W	frame LENgth upper LiMIT value Sets the maximum receive frame length (Including CRC). If the receive frame length exceeds the set value, frame length error (RINT4) is asserted.																										
				<table border="0"> <tr> <td style="text-align: center;">< Set value ></td> <td style="text-align: center;">< Check value ></td> </tr> <tr> <td>H'00000 to H'005EE</td> <td>1518 Byte</td> </tr> <tr> <td>H'005EF</td> <td>1519 Byte</td> </tr> <tr> <td>H'005F0</td> <td>1520 Byte</td> </tr> <tr> <td>...</td> <td></td> </tr> <tr> <td>H'007FF</td> <td>2047 Byte</td> </tr> <tr> <td>H'00800</td> <td>2048 Byte</td> </tr> <tr> <td>...</td> <td></td> </tr> <tr> <td>H'01000</td> <td>4096 Byte</td> </tr> <tr> <td>...</td> <td></td> </tr> <tr> <td>H'10000</td> <td>65536 Byte</td> </tr> <tr> <td>...</td> <td></td> </tr> <tr> <td>H'20000 to H'3FFFF</td> <td>131072 Byte</td> </tr> </table>	< Set value >	< Check value >	H'00000 to H'005EE	1518 Byte	H'005EF	1519 Byte	H'005F0	1520 Byte	...		H'007FF	2047 Byte	H'00800	2048 Byte	...		H'01000	4096 Byte	...		H'10000	65536 Byte	...		H'20000 to H'3FFFF	131072 Byte
< Set value >	< Check value >																													
H'00000 to H'005EE	1518 Byte																													
H'005EF	1519 Byte																													
H'005F0	1520 Byte																													
...																														
H'007FF	2047 Byte																													
H'00800	2048 Byte																													
...																														
H'01000	4096 Byte																													
...																														
H'10000	65536 Byte																													
...																														
H'20000 to H'3FFFF	131072 Byte																													

30.4.2.3 Interrupt status register (CXR21)

CXR21 indicates interrupt status.

Read restrictions:

When the PHY used does not have an INT signal, consider the read value of PHYI bit (bit3) as undefined.

Write restrictions:

Writing 0 is invalid. 1 or 0 cannot be written to bit 3.

Bit	31	30	29	28	27	26	25	24	23	22	21	20	19	18	17	16
	—	—	—	—	—	—	—	—	—	—	—	—	—	—	—	—
Initial Value	0	0	0	0	0	0	0	0	0	0	0	0	0	0	0	0
R/W	R	R	R	R	R	R	R	R	R	R	R	R	R	R	R	R
Bit	15	14	13	12	11	10	9	8	7	6	5	4	3	2	1	0
	—	—	—	—	—	—	—	—	—	—	—	PFRI	PHYI	LINKI	—	FCI
Initial Value	0	0	0	0	0	0	0	0	0	0	0	0	X	0	0	0
R/W	R	R	R	R	R	R	R	R	R	R	R	R/W	R/W	R/W	R	R/W

Bit	Bit Name	Initial Value	R/W	Description
31 to 5	—	All 0	R	Reserved Whenever it is read, 0 is read. The written value will be ignored.
4	PFRI	0b	R/W	PAUSE Frame Retry Interrupt Interrupt source based on the PAUSE frame transmission retry count: Indicates that the PAUSE frame transmission is retried for the number of times specified using the CXR81 register. This bit can be cleared to 0 in the following way. (1) Read the CXR82 register to clear CXR82. (2) Write 1 to this bit.
3	PHYI	Xb	R/W	PHY Interrupt PHY chip interrupt source: Indicates status of 'PHY INT' of the E-MAC input/output signals. 1: Interrupt from PHY is asserted. 0: Interrupt from PHY is negated. Signal polarity of 'PHY INT' can be set using CXR2C. <i>Note:</i> When the PHY used does not have an INT signal, the read value of this bit should be undefined.
2	LINKI	0b	R/W	LINK Interrupt Link status change interrupt source: Indicates that on/off of bit 0 (LINK) of CXR2B has changed. Write 1 to clear this bit. <i>Note:</i> Before referring to this bit, determine whether to use PHY_LINK input signal or RGMII-Inband Status LINK bit as the link using SEL_LINK (bit 0) in the CXR31 register.
1	—	0b	R	Reserved When read, the initial value is read. When writing, be sure to write the initial value. Operation is not guaranteed if a value other than the initial value is written.

Bit	Bit Name	Initial Value	R/W	Description
0	FCI	0b	R/W	False Carrier Interrupt Invalid carrier detected interrupt source: Indicates that an invalid carrier was detected in the PHY chip. Write 1 to clear this bit to 0.

30.4.2.4 Enables/disables interrupts register (CXR22)

CXR22 enables/disables interrupts.

It is possible to enable/disable interrupts for each interrupt source indicated in CXR21 (bit unit).

Write restrictions:

If the PHY used does not have an INT signal, set PHYIM bit (bit 3) to 0. In the case of without using PHY_LINK signal and without using RGMII Inband Status function (case of setting '10' or '11' to SEL_LINK of CXR31), set PHYIM bit (bit 2) to 0.

Bit	31	30	29	28	27	26	25	24	23	22	21	20	19	18	17	16
	—	—	—	—	—	—	—	—	—	—	—	—	—	—	—	—
Initial Value	0	0	0	0	0	0	0	0	0	0	0	0	0	0	0	0
R/W	R	R	R	R	R	R	R	R	R	R	R	R	R	R	R	R
Bit	15	14	13	12	11	10	9	8	7	6	5	4	3	2	1	0
	—	—	—	—	—	—	—	—	—	—	—	PFRIM	PHYIM	LINKIM	—	FCIM
Initial Value	0	0	0	0	0	0	0	0	0	0	0	0	0	0	0	0
R/W	R	R	R	R	R	R	R	R	R	R	R	R/W	R/W	R/W	R	R/W

Bit	Bit Name	Initial Value	R/W	Description
31 to 5	—	All 0	R	Reserved Whenever it is read, 0 is read. The written value will be ignored.
4	PFRIM	0b	R/W	PAUSE Frame Retry Interrupt Mask 1: Interrupt by PFRM bit in the CXR21 register is enabled. 0: Interrupt by PFRM bit in the CXR21 register is disabled.
3	PHYIM	0b	R/W	PHY Interrupt Mask 1: Interrupt by PHYI bit in the CXR21 register is enabled. 0: Interrupt by PHYI bit in the CXR21 register is disabled. <i>Note:</i> If the PHY used does not have an INT signal, set this bit to 0.
2	LINKIM	0b	R/W	LINK Interrupt Mask 1: Interrupt by LINKI bit in the CXR21 register is enabled. 0: Interrupt by LINKI bit in the CXR21 register is disabled.
1	—	0b	R	Reserved When read, the initial value is read. When writing, be sure to write the initial value. Operation is not guaranteed if a value other than the initial value is written.
0	FCIM	0b	R/W	False Carrier Interrupt Mask 1: Interrupt by FCI bit in the CXR21 register is enabled. 0: Interrupt by FCI bit in the CXR21 register is disabled.

30.4.2.5 PHY register access register (CXR23)

There are two methods to access the PHY register: using the E-MAC-MDIO block and using the CXR23 register.

Which access method to be used can be set using the MDIOMOD register.

For PHY register access using CXR23, see **Section 30.5.14.3(2), PHY Register Access Method (Using CXR23)** and IEEE Standard 802.3, 2000 Edition “22.2.4.5 Management frame structure.”

Write restrictions:

Writing bit 3 is invalid.

Bit	31	30	29	28	27	26	25	24	23	22	21	20	19	18	17	16
	—	—	—	—	—	—	—	—	—	—	—	—	—	—	—	—
Initial Value	0	0	0	0	0	0	0	0	0	0	0	0	0	0	0	0
R/W	R	R	R	R	R	R	R	R	R	R	R	R	R	R	R	R
Bit	15	14	13	12	11	10	9	8	7	6	5	4	3	2	1	0
	—	—	—	—	—	—	—	—	—	—	—	—	MDI	MDO	MM	MDC
Initial Value	0	0	0	0	0	0	0	0	0	0	0	0	X	0	0	0
R/W	R	R	R	R	R	R	R	R	R	R	R	R	R/W	R/W	R/W	R/W

Bit	Bit Name	Initial Value	R/W	Description
31 to 4	—	All 0	R	Reserved Whenever it is read, 0 is read. The written value will be ignored.
3	MDI	Xb	R/W	Management Data Input
2	MDO	0b	R/W	Management Data Output
1	MM	0b	R/W	Management Data Management mode The write value should be 1. The read value should be 0.
0	MDC	0b	R/W	Management Clock

30.4.2.6 Link status register (CXR2B)

CXR2B indicates link status.

Write restrictions:

Write disabled

Bit	31	30	29	28	27	26	25	24	23	22	21	20	19	18	17	16
	—	—	—	—	—	—	—	—	—	—	—	—	—	—	—	—
Initial Value	0	0	0	0	0	0	0	0	0	0	0	0	0	0	0	0
R/W	R	R	R	R	R	R	R	R	R	R	R	R	R	R	R	R
Bit	15	14	13	12	11	10	9	8	7	6	5	4	3	2	1	0
	—	—	—	—	—	—	—	—	—	—	—	—	SOFT_LINK	SIGNAL_LINK	INBAND_LINK	LINK
Initial Value	0	0	0	0	0	0	0	0	0	0	0	0	0	0	X	0
R/W	R	R	R	R	R	R	R	R	R	R	R	R	R	R	R	R

Bit	Bit Name	Initial Value	R/W	Description
31 to 4	—	All 0	R	Reserved Whenever it is read, 0 is read. The written value will be ignored.
3	SOFT_LINK	0b	R	Software LINK Indicates the LINK ON/OFF status of software LINK setting (CXR2G) 1: Link ON (Link Up) 0: Link OFF (Link Down) This bit indicates the value of CXR2G.
2	SIGNAL_LINK	0b	R	LINK signal input Indicates the LINK ON/OFF status of the PHY_LINK input signal. 1: Link ON (Link Up) 0: Link OFF (Link Down) <i>Note:</i> Before referring to this bit, set the polarity of the PHY_LINK input signal using PHYLINKP (bit 1) in the CXR2C register.
1	INBAND_LINK	Xb	R	Inband Status LINK Indicates the link bit of RGMII Inband status. 1: Link ON (Link Up) 0: Link OFF (Link Down) <i>Note:</i> If the PHY used does not support Inband-status, the read value of this bit should be undefined.
0	LINK	0b	R	LINK status Indicates link status. 1: Link ON (Link Up) 0: Link OFF (Link Down) <i>Note:</i> Before referring to this bit, determine whether to use the PHY_LINK input signal, RGMII-Inband Status LINK bit or software LINK as the link using SEL_LINK (bit3, bit0) in the CXR31 register. In addition, to use the PHY_LINK input signal, set the polarity of PHY_LINK input using PHYLINKP (bit 1) in the CXR2C register.

30.4.2.7 Polarity set register (CXR2C)

CXR2C sets the polarity of 'PHY_LINK' and 'PHY_INT' signals.

Write restrictions:

Rewrite to this register with bits 2 and 3 in CXR22 being 0.

Bit	31	30	29	28	27	26	25	24	23	22	21	20	19	18	17	16
	—	—	—	—	—	—	—	—	—	—	—	—	—	—	—	—
Initial Value	0	0	0	0	0	0	0	0	0	0	0	0	0	0	0	0
R/W	R	R	R	R	R	R	R	R	R	R	R	R	R	R	R	R
Bit	15	14	13	12	11	10	9	8	7	6	5	4	3	2	1	0
	—	—	—	—	—	—	—	—	—	—	—	—	—	—	PHYLINKP	PHYIP
Initial Value	0	0	0	0	0	0	0	0	0	0	0	0	0	0	0	0
R/W	R	R	R	R	R	R	R	R	R	R	R	R	R	R	R/W	R/W

Bit	Bit Name	Initial Value	R/W	Description
31 to 2	—	All 0	R	Reserved Whenever it is read, 0 is read. The written value will be ignored.
1	PHYLINKP	0b	R/W	PHY_LINK Polarity Sets polarity of input signal 'avb_miimg_link'. 1: High active (LINK ON [LINK UP] status with high) 0: Low active (LINK ON [LINK UP] status with low)
0	PHYIP	0b	R/W	PHY Interrupt Polarity Sets polarity of input signal 'avb_miimg_int'. 1: High active (interrupt status with high) 0: Low active (interrupt status with low)

30.4.2.8 In-Band Status set register (CXR31)

CXR31 sets whether to apply In-Band Status function*1 of RGMII-IF to the E-MAC operating mode.

It is possible to select the configured value by software for Link status.

Note 1. In-Band Status function (optional) is a notification function from PHY to E-MAC about Link Status (Up/Down), transmission speed (10 M/100 M/1 G) and Duplex (Half/Full) via RGMII-IF.

Write restrictions:

Rewrite to this register with transmission function disabled (CXR20 TPE = 0) and reception function also disabled (CXR20 RPE = 0). If the PHY used does not support In-band Status, set 'H'000000' to this register.

Bit	31	30	29	28	27	26	25	24	23	22	21	20	19	18	17	16
	—	—	—	—	—	—	—	—	—	—	—	—	—	—	—	—
Initial Value	0	0	0	0	0	0	0	0	0	0	0	0	0	0	0	0
R/W	R	R	R	R	R	R	R	R	R	R	R	R	R	R	R	R
Bit	15	14	13	12	11	10	9	8	7	6	5	4	3	2	1	0
	—	—	—	—	—	—	—	—	—	—	—	—	SEL_LINK[1]	SEL_SPEED	SEL_DUPLEX	SEL_LINK[0]
Initial Value	0	0	0	0	0	0	0	0	0	0	0	0	0	0	0	0
R/W	R	R	R	R	R	R	R	R	R	R	R	R	R/W	R/W	R/W	R/W

Bit	Bit Name	Initial Value	R/W	Description
31 to 4	—	All 0	R	Reserved When read, the initial value is read. When writing, be sure to write the initial value. Operation is not guaranteed if a value other than the initial value is written.
3	SEL_LINK[1]	0b	R/W	Select LINK See bit0 of this register.
2	SEL_SPEED	0b	R/W	Select Speed*1, *2 '1': The information from In-band Status is used for setting the E-MAC operation speed. '0': CXR2D register value is used for setting the E-MAC operation speed.
1	SEL_DUPLEX	0b	R/W	Select Duplex*1, *2 '1': The information from In-band Status is used for setting Full/Half Duplex. '0': CXR20 DPM bit value is used for setting Full/Half Duplex.
0	SEL_LINK[0]	0b	R/W	Select LINK*1, *2 SEL_LINK [1:0] '11': The information from CXR20 TPE bit value is used for setting the LINK.*3 The status of CXR20 TPE bit is set to CXR2B LINK bit. When this value is set, set '0' (disable LINK interrupt) to CXR22 LINKIM bit. '10': The information from CXR2B SOFTWR_LINK bit value is used for setting the LINK.*3 The status of CXR2G SOFT_LINK bit is set to CXR2B LINK bit. When this value is set, set '0' (disable LINK interrupt) to CXR22 LINKIM bit. '01': The information from In-band Status is used for setting the LINK. '00': The information from the PHY_LINK input signal is used for setting the LINK.

Note 1. If the PHY does not support In-band Status is used or If MII-IF is used, do not set value using In-band Status.

Note 2. If the device driver software is developed as common for MII-IF and RGMII-IF, not using this register is recommended.

Note 3. When Low Power Mode E-MAC is used, it needs to know the status of PHY as Link Up (Link ON). But, when it does not have the information to judge the status of LINK (because MII-IF is used and PHY_LINK signal is not used), set '10' or '11'.
In the case of SEL_LINK [1:0] = '10', CXR2B SOFT_LINK is used. So, software has to check the LINK status by register of

PHY and set that information to CXR2G.
In the case of SEL_LINK [1:0] = '11', CXR20 TPE is used as LINK status.

30.4.2.9 In-Band Status indicate register (CXR32)

CXR32 indicates In-Band-Status of RGMII-IF.

In-Band Status function (option) is the function that the PHY notifies the E-MAC of link status (Up/Down), transfer rate (10 M/100 M/1 G) and duplex (full or half duplex), using the RGMII interface signal.

Write restrictions:

Write disabled

Bit	31	30	29	28	27	26	25	24	23	22	21	20	19	18	17	16
	—	—	—	—	—	—	—	—	—	—	—	—	—	—	—	—
Initial Value	0	0	0	0	0	0	0	0	0	0	0	0	0	0	0	0
R/W	R	R	R	R	R	R	R	R	R	R	R	R	R	R	R	R
Bit	15	14	13	12	11	10	9	8	7	6	5	4	3	2	1	0
	—	—	—	—	—	—	—	—	—	—	—	—	INBAND_SPEED	INBAND_DUPLEX	INBAND_LINK	
Initial Value	0	0	0	0	0	0	0	0	0	0	0	0	X	X	X	X
R/W	R	R	R	R	R	R	R	R	R	R	R	R	R	R	R	R

Bit	Bit Name	Initial Value	R/W	Description
31 to 4	—	All 0	R	Reserved Whenever it is read, 0 is read. The written value will be ignored.
3 to 2	INBAND_SPEED	XXb	R	In-Band Status Speed*1 '10': Indicates that the speed of RGMII In-Band status is 1 Gbps. '01': Indicates that the speed of RGMII In-Band status is 100 Mbps. '00': Indicates that the speed of RGMII In-Band status is 10 Mbps.
1	INBAND_DUPLEX	Xb	R	In-Band Status Duplex*1 '1': Indicates that the Duplex bit of RGMII In-Band status is Full Duplex. '0': Indicates that the Duplex bit of RGMII In-Band status is Half Duplex.
0	INBAND_LINK	Xb	R	In-Band Status LINK*1 '1': Indicates that LINK of RGMII In-Band status is LINK ON (LINK UP). '0': Indicates that LINK of RGMII In-Band status is LINK OFF (LINK DOWN).

Note 1. If the PHY used does not support Inband-status, the read value of those bits should be undefined.

30.4.2.10 Mode indicate register (CXR33)

CXR33 indicates the speed, duplex, and link operating mode of the E-MAC.

Write restrictions:

Write disabled

Bit	31	30	29	28	27	26	25	24	23	22	21	20	19	18	17	16
	—	—	—	—	—	—	—	—	—	—	—	—	—	—	—	—
Initial Value	0	0	0	0	0	0	0	0	0	0	0	0	0	0	0	0
R/W	R	R	R	R	R	R	R	R	R	R	R	R	R	R	R	R
Bit	15	14	13	12	11	10	9	8	7	6	5	4	3	2	1	0
	—	—	—	—	—	—	—	—	—	—	—	—	SPEED[1:0]		DUPLEX	LINK
Initial Value	0	0	0	0	0	0	0	0	0	0	0	0	0	0	0	0
R/W	R	R	R	R	R	R	R	R	R	R	R	R	R	R	R	R

Bit	Bit Name	Initial Value	R/W	Description
31 to 4	—	All 0	R	Reserved Whenever it is read, 0 is read. The written value will be ignored.
3 to 2	SPEED	00b	R	Speed ‘10’: Transfer rate mode of E-MAC is 1 Gbps. ‘01’: Transfer rate mode of E-MAC is 100 Mbps. ‘00’: Transfer rate mode of E-MAC is 10 Mbps.
1	DUPLEX	0b	R	Duplex ‘1’: Duplex mode of E-MAC is Full Duplex. ‘0’: Duplex mode of E-MAC is Half Duplex.
0	LINK	0b	R	LINK ‘1’: LINK status is Link On (Link Up). ‘0’: LINK status is Link Off (Link Down).

30.4.2.11 PHY interface select register (CXR35)

CXR35 selects RGMII or MII interface.

Write restrictions:

- (1) After release reset, make write-access to this register before making write-access to other registers (except MDIOMOD). Even if not need to change the value of this register, make write-access to this register at least one time. Because RGMII/MII MODE is recognized by accessing this register.
- (2) If need to re-write the value of this register after making write-access to other register, reset to E-MAC is needed.
- (3) If need to re-write the value of this register without making write-access to other register, wait the quadruple time which is set at HALFCYC_CLKSW.

Bit	31	30	29	28	27	26	25	24	23	22	21	20	19	18	17	16
	HALFCYC_CLKSW[15:0]															
Initial Value	1	1	1	1	1	1	1	1	1	1	1	1	1	1	1	1
R/W	R/W	R/W	R/W	R/W	R/W	R/W	R/W	R/W	R/W	R/W	R/W	R/W	R/W	R/W	R/W	R/W
Bit	15	14	13	12	11	10	9	8	7	6	5	4	3	2	1	0
	—	—	—	SEL_M ODPOL	—	—	—	SEL_M ODIN	—	—	—	—	—	—	SEL_XMII[1:0]	
Initial Value	0	0	0	0	0	0	0	0	0	0	0	0	0	0	0	0
R/W	R	R	R	R/W	R	R	R	R/W	R	R	R	R	R	R	R/W	R/W

Bit	Bit Name	Initial Value	R/W	Description
31 to 16	HALFCYC_C LKSW	H'FFFF	R/W	A clock stop time at the clock switching The wait time (over 20 us) is needed when PHY interface is selected at initializing Gigabit Ethernet Interface. Set the number of clk_chi (APB clock) cycle to be half of wait time (over 10 us). H'0000: 1 cycle of clk_chi H'0001: 2 cycle of clk_chi H'0002: 3 cycle of clk_chi ... H'03E8: 1000 cycle of clk_chi (If clk_chi is 100 MHz (10 ns), half of wait time will be 10 us) H'07D0: 2000 cycle of clk_chi (If clk_chi is 200 MHz (5 ns), half of wait time will be 10 us) ... H'FFFF: 65536 cycle of clk_chi (default value)
15 to 13	—	All 0	R	Reserved Whenever it is read, 0 is read. The written value will be ignored.
12	SEL_MODPOL	0b	R/W	polar selection of RGMII/MII Mode input signal '0': (default value) E-MAC recognizes RGMII-IF is used. '1': E-MAC recognizes MII-IF is used.
11 to 9	—	All 0	R	Reserved Whenever it is read, 0 is read. The written value will be ignored.
8	SEL_MODIN	0b	R/W	method for selection of RGMII/MII '0': SEL_XMII field of this register is used for RGMII/MII selection (default value) '1': Reserved
7 to 2	—	All 0	R	Reserved Whenever it is read, 0 is read. The written value will be ignored.

Bit	Bit Name	Initial Value	R/W	Description
1 to 0	SEL_XMII	00b	R/W	<p>Selection of PHY interface to be used</p> <p>'00': RGMII interface is used (default value)</p> <p>'01': Reserved</p> <p>'10': MII interface is used</p> <p>'11': Reserved</p> <p><i>Note:</i> The case of SEL_MODIN (bit8) = '0', this field is used to select PHY interface.</p> <p>The case of SEL_MODIN (bit8) = '1', this field is not used and Mode signals which is provided from out of E-MAC is used to select PHY interface.</p>

Note: This register needs to write access at least one time.

[A] The case which CXR35 SEL_XMII is used for the selection of RGMII/MII in APB Clock 100 MHz.

- (1) To use RGMII interface, Set 'H'03E8 0000' to this register.
- (2) To use MII interface, Set 'H'03E8 0002' to this register.

30.4.2.12 PHY interface indicate register (CX36)

CXR36 indicates the status of RGMII/MII Interface.

Write restrictions:

Write disabled

Bit	31	30	29	28	27	26	25	24	23	22	21	20	19	18	17	16
	—	—	—	—	—	—	—	—	—	—	—	—	—	—	—	—
Initial Value	0	0	0	0	0	0	0	0	0	0	0	0	0	0	0	0
R/W	R	R	R	R	R	R	R	R	R	R	R	R	R	R	R	R
Bit	15	14	13	12	11	10	9	8	7	6	5	4	3	2	1	0
	—	—	—	—	—	—	—	—	—	—	—	—	—	—	STS_XMII[1:0]	
Initial Value	0	0	0	0	0	0	0	0	0	0	0	0	0	0	0	0
R/W	R	R	R	R	R	R	R	R	R	R	R	R	R	R	R	R

Bit	Bit Name	Initial Value	R/W	Description
31 to 2	—	All 0	R	Reserved When read, the initial value is read. When writing, be sure to write the initial value. Operation is not guaranteed if a value other than the initial value is written.
1 to 0	STS_XMII	00b	R	Status of selected PHY interface '00': RGMII interface '01': Reserved '10': MII interface '11': Reserved

30.4.2.13 PAUSE frame register 1 (CXR71)

CXR71 sets the timer value for Auto PAUSE frame.

Write restrictions:

Set a value other than all 0 when transmission system flow control is enabled. (CXR20_bit16 = 1)

Bit	31	30	29	28	27	26	25	24	23	22	21	20	19	18	17	16
	—	—	—	—	—	—	—	—	—	—	—	—	—	—	—	—
Initial Value	0	0	0	0	0	0	0	0	0	0	0	0	0	0	0	0
R/W	R	R	R	R	R	R	R	R	R	R	R	R	R	R	R	R
Bit	15	14	13	12	11	10	9	8	7	6	5	4	3	2	1	0
	APFTP[15:0]															
Initial Value	0	0	0	0	0	0	0	0	0	0	0	0	0	0	0	0
R/W	R/W	R/W	R/W	R/W	R/W	R/W	R/W	R/W	R/W	R/W	R/W	R/W	R/W	R/W	R/W	R/W

Bit	Bit Name	Initial Value	R/W	Description																						
31 to 16	—	All 0	R	Reserved Whenever it is read, 0 is read. The written value will be ignored.																						
15 to 0	APFTP	H'0000	R/W	Auto Pause Frame Time Parameter The value set in this register is used as the Timer value for PAUSE frame during Auto PAUSE Frame transmission. <i>Note:</i> Set the value of this register to other than 0000 when transmission system flow control is enabled (CXR20_bit 16 = 1). <table border="0" style="margin-left: 40px;"> <tr> <td style="text-align: right;"><set value></td> <td style="text-align: left;"><bit time></td> </tr> <tr> <td style="text-align: right;">H'0000</td> <td style="text-align: left;">—</td> </tr> <tr> <td style="text-align: right;">H'0001</td> <td style="text-align: left;">512 × 1 bit time</td> </tr> <tr> <td style="text-align: right;">H'0002</td> <td style="text-align: left;">512 × 2 bit time</td> </tr> <tr> <td style="text-align: right;">H'0003</td> <td style="text-align: left;">512 × 3 bit time</td> </tr> <tr> <td style="text-align: right;">...</td> <td></td> </tr> <tr> <td style="text-align: right;">H'FFFF</td> <td style="text-align: left;">512 × 65535 bit time</td> </tr> </table> <table border="0" style="margin-left: 40px;"> <tr> <td style="text-align: right;"><transfer rate></td> <td style="text-align: left;"><1 bit time></td> </tr> <tr> <td style="text-align: right;">1000 Mbps</td> <td style="text-align: left;">1 ns</td> </tr> <tr> <td style="text-align: right;">100 Mbps</td> <td style="text-align: left;">10 ns</td> </tr> <tr> <td style="text-align: right;">10 Mbps</td> <td style="text-align: left;">100 ns</td> </tr> </table>	<set value>	<bit time>	H'0000	—	H'0001	512 × 1 bit time	H'0002	512 × 2 bit time	H'0003	512 × 3 bit time	...		H'FFFF	512 × 65535 bit time	<transfer rate>	<1 bit time>	1000 Mbps	1 ns	100 Mbps	10 ns	10 Mbps	100 ns
<set value>	<bit time>																									
H'0000	—																									
H'0001	512 × 1 bit time																									
H'0002	512 × 2 bit time																									
H'0003	512 × 3 bit time																									
...																										
H'FFFF	512 × 65535 bit time																									
<transfer rate>	<1 bit time>																									
1000 Mbps	1 ns																									
100 Mbps	10 ns																									
10 Mbps	100 ns																									

30.4.2.14 PAUSE frame register 2 (CXR72)

CXR72 starts the transmission of Manual PAUSE frames and sets the timer value for Manual PAUSE frame.

Bit	31	30	29	28	27	26	25	24	23	22	21	20	19	18	17	16
	—	—	—	—	—	—	—	—	—	—	—	—	—	—	—	—
Initial Value	0	0	0	0	0	0	0	0	0	0	0	0	0	0	0	0
R/W	R	R	R	R	R	R	R	R	R	R	R	R	R	R	R	R
Bit	15	14	13	12	11	10	9	8	7	6	5	4	3	2	1	0
	MPFTP[15:0]															
Initial Value	0	0	0	0	0	0	0	0	0	0	0	0	0	0	0	0
R/W	R/W	R/W	R/W	R/W	R/W	R/W	R/W	R/W	R/W	R/W	R/W	R/W	R/W	R/W	R/W	R/W

Bit	Bit Name	Initial Value	R/W	Description																								
31 to 16	—	All 0	R	Reserved Whenever it is read, 0 is read. The written value will be ignored.																								
15 to 0	MPFTP	H'0000	R/W	Manual Pause Frame Time Parameter When a value is written to this register, PAUSE frame transmission is started using the value as the timer value.																								
				<table border="0"> <tr> <td style="padding-right: 20px;"><set value></td> <td><bit time></td> </tr> <tr> <td>H'0000</td> <td>—</td> </tr> <tr> <td>H'0001</td> <td>512 × 1 bit time</td> </tr> <tr> <td>H'0002</td> <td>512 × 2 bit time</td> </tr> <tr> <td>H'0003</td> <td>512 × 3 bit time</td> </tr> <tr> <td>...</td> <td></td> </tr> <tr> <td>H'FFFF</td> <td>512 × 65535 bit time</td> </tr> <tr> <td colspan="2"> </td> </tr> <tr> <td style="padding-right: 20px;"><transfer rate></td> <td><1 bit time></td> </tr> <tr> <td>1000 Mbps</td> <td>1 ns</td> </tr> <tr> <td>100 Mbps</td> <td>10 ns</td> </tr> <tr> <td>10 Mbps</td> <td>100 ns</td> </tr> </table>	<set value>	<bit time>	H'0000	—	H'0001	512 × 1 bit time	H'0002	512 × 2 bit time	H'0003	512 × 3 bit time	...		H'FFFF	512 × 65535 bit time			<transfer rate>	<1 bit time>	1000 Mbps	1 ns	100 Mbps	10 ns	10 Mbps	100 ns
<set value>	<bit time>																											
H'0000	—																											
H'0001	512 × 1 bit time																											
H'0002	512 × 2 bit time																											
H'0003	512 × 3 bit time																											
...																												
H'FFFF	512 × 65535 bit time																											
<transfer rate>	<1 bit time>																											
1000 Mbps	1 ns																											
100 Mbps	10 ns																											
10 Mbps	100 ns																											

30.4.2.15 PAUSE frame register 3 (CX8A)

CXR8A is a transmit counter for PAUSE frame.

Bit	31	30	29	28	27	26	25	24	23	22	21	20	19	18	17	16
	—	—	—	—	—	—	—	—	—	—	—	—	—	—	—	—
Initial Value	0	0	0	0	0	0	0	0	0	0	0	0	0	0	0	0
R/W	R	R	R	R	R	R	R	R	R	R	R	R	R	R	R	R
Bit	15	14	13	12	11	10	9	8	7	6	5	4	3	2	1	0
	PFTXC[15:0]															
Initial Value	0	0	0	0	0	0	0	0	0	0	0	0	0	0	0	0
R/W	R/W	R/W	R/W	R/W	R/W	R/W	R/W	R/W	R/W	R/W	R/W	R/W	R/W	R/W	R/W	R/W

Bit	Bit Name	Initial Value	R/W	Description
31 to 16	—	All 0	R	Reserved Whenever it is read, 0 is read. The written value will be ignored.
15 to 0	PFTXC	H'0000	R/W	Pause Frame TX Counter Indicates the number of times of transmission of Auto PAUSE frames and Manual PAUSE frames in total. This register is cleared to 0 when read.

30.4.2.16 PAUSE frame register 4 (CX80)

CXR80 is a receive counter for PAUSE frame.

Bit	31	30	29	28	27	26	25	24	23	22	21	20	19	18	17	16
	—	—	—	—	—	—	—	—	—	—	—	—	—	—	—	—
Initial Value	0	0	0	0	0	0	0	0	0	0	0	0	0	0	0	0
R/W	R	R	R	R	R	R	R	R	R	R	R	R	R	R	R	R
Bit	15	14	13	12	11	10	9	8	7	6	5	4	3	2	1	0
	PFRXC[15:0]															
Initial Value	0	0	0	0	0	0	0	0	0	0	0	0	0	0	0	0
R/W	R/W	R/W	R/W	R/W	R/W	R/W	R/W	R/W	R/W	R/W	R/W	R/W	R/W	R/W	R/W	R/W

Bit	Bit Name	Initial Value	R/W	Description
31 to 16	—	All 0	R	Reserved Whenever it is read, 0 is read. The written value will be ignored.
15 to 0	PFRXC	H'0000	R/W	Pause Frame RX Counter Indicates the number of PAUSE frames received when receive system flow control is enabled (CX820_bit17 = 1). This register is cleared to 0 when read.

30.4.2.17 PAUSE frame register 5 (CXR81)

CXR81 sets the upper limit of the number of autonomous transmissions of PAUSE frame.

Write restrictions:

Rewriting this register is prohibited when 1 is set to CXR20_bit 5.

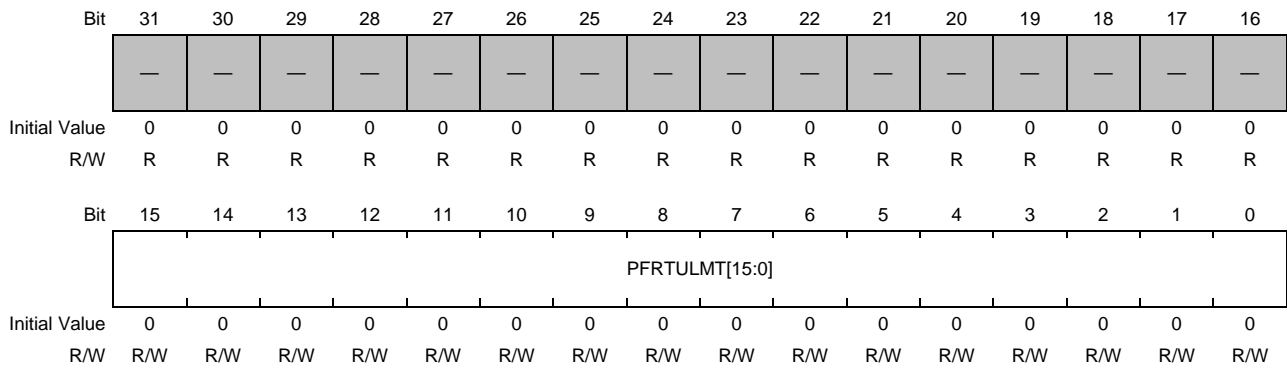

Bit	Bit Name	Initial Value	R/W	Description														
31 to 16	—	All 0	R	Reserved Whenever it is read, 0 is read. The written value will be ignored.														
15 to 0	PFRTULMT	H'0000	R/W	<p>Pause Frame Retry Upper LiMiT</p> <p>Sets the number of times of Auto PAUSE frame transmission (upper limit) from the time of asserting "Reception FIFO Critical Level Notification" from DMAC assertion to negation.</p> <table border="0" style="margin-left: 40px;"> <tr> <td style="padding-right: 20px;"><set value></td> <td><Number of transmissions></td> </tr> <tr> <td>H'0000</td> <td>No limit</td> </tr> <tr> <td>H'0001</td> <td>1 time</td> </tr> <tr> <td>H'0002</td> <td>2 times</td> </tr> <tr> <td>H'0003</td> <td>3 times</td> </tr> <tr> <td>...</td> <td></td> </tr> <tr> <td>H'FFFF</td> <td>65535 times</td> </tr> </table>	<set value>	<Number of transmissions>	H'0000	No limit	H'0001	1 time	H'0002	2 times	H'0003	3 times	...		H'FFFF	65535 times
<set value>	<Number of transmissions>																	
H'0000	No limit																	
H'0001	1 time																	
H'0002	2 times																	
H'0003	3 times																	
...																		
H'FFFF	65535 times																	

30.4.2.18 PAUSE frame register 6 (CXR82)

CXR82 counter indicates the number of Auto PAUSE frame transmissions from “Reception FIFO Critical Level Notification” from DMAC assertion to negation.

Write restrictions:

Write disabled

Bit	31	30	29	28	27	26	25	24	23	22	21	20	19	18	17	16
	—	—	—	—	—	—	—	—	—	—	—	—	—	—	—	—
Initial Value	0	0	0	0	0	0	0	0	0	0	0	0	0	0	0	0
R/W	R	R	R	R	R	R	R	R	R	R	R	R	R	R	R	R
Bit	15	14	13	12	11	10	9	8	7	6	5	4	3	2	1	0
	PFRTC[15:0]															
Initial Value	0	0	0	0	0	0	0	0	0	0	0	0	0	0	0	0
R/W	R	R	R	R	R	R	R	R	R	R	R	R	R	R	R	R

Bit	Bit Name	Initial Value	R/W	Description
31 to 16	—	All 0	R	Reserved Whenever it is read, 0 is read. The written value will be ignored.
15 to 0	PFRTC	H'FFFF	R	Pause Frame Retry Counter Indicates the number of times of Auto PAUSE frame transmission from “Reception FIFO Critical Level Notification” from DMAC assertion to negation. This register is cleared to 0 when read and at the start of “Reception FIFO Critical Level Notification” from DMAC assertion.

30.4.2.19 E-MAC operating mode register 2 (CXR2D)

CXR2D sets the operating mode of the E-MAC.

Rewriting this register bits is prohibited with transmission function enabled (CXR20<TPE> = 1) and reception function enabled (CXR20<RPE> = 1).

Write restrictions:

Rewriting this register is prohibited when 1 is set to CXR20_bit 5 or 6.

Bit	31	30	29	28	27	26	25	24	23	22	21	20	19	18	17	16
	—	—	—	—	—	—	—	—	—	—	—	—	—	—	—	—
Initial Value	0	0	0	0	0	0	0	0	0	0	0	0	0	0	0	0
R/W	R	R	R	R	R	R	R	R	R	R	R	R	R	R	R	R
Bit	15	14	13	12	11	10	9	8	7	6	5	4	3	2	1	0
	—	—	—	—	—	—	—	—	—	—	SPEED[1:0]		—	—	—	—
Initial Value	0	0	0	0	0	0	0	0	0	0	0	0	0	0	0	0
R/W	R	R	R	R	R	R	R	R	R	R	R/W	R/W	R	R	R	R

Bit	Bit Name	Initial Value	R/W	Description															
31 to 6	—	All 0	R	Reserved When read, the initial value is read. When writing, be sure to write the initial value. Operation is not guaranteed if a value other than the initial value is written.															
5 to 4	SPEED	00b	R/W	Transmit SPEED Set transfer rate. <table border="1"> <thead> <tr> <th>SPEED[1] bit5</th> <th>SPEED[0] bit4</th> <th>Transmit Speed</th> </tr> </thead> <tbody> <tr> <td>0</td> <td>0</td> <td>10 Mbps</td> </tr> <tr> <td>0</td> <td>1</td> <td>100 Mbps</td> </tr> <tr> <td>1</td> <td>0</td> <td>1000 Mbps</td> </tr> <tr> <td>1</td> <td>1</td> <td>Reserved</td> </tr> </tbody> </table>	SPEED[1] bit5	SPEED[0] bit4	Transmit Speed	0	0	10 Mbps	0	1	100 Mbps	1	0	1000 Mbps	1	1	Reserved
SPEED[1] bit5	SPEED[0] bit4	Transmit Speed																	
0	0	10 Mbps																	
0	1	100 Mbps																	
1	0	1000 Mbps																	
1	1	Reserved																	
3 to 0	—	All 0	R	Reserved When read, the initial value is read. When writing, be sure to write the initial value. Operation is not guaranteed if a value other than the initial value is written.															

30.4.2.20 Software LINK status register (CXR2G)

CXR2G indicates the status of Software LINK.

Write restrictions:

Before setting '1' to this register, set SEL_LINK of CXR31 whether using PHY_LINK input signal, using LINK bit of RGMII-Inband Status or using LINK setting by software.

Bit	31	30	29	28	27	26	25	24	23	22	21	20	19	18	17	16
	—	—	—	—	—	—	—	—	—	—	—	—	—	—	—	—
Initial Value	0	0	0	0	0	0	0	0	0	0	0	0	0	0	0	0
R/W	R	R	R	R	R	R	R	R	R	R	R	R	R	R	R	R
Bit	15	14	13	12	11	10	9	8	7	6	5	4	3	2	1	0
	—	—	—	—	—	—	—	—	—	—	—	—	SOFT_L INK	—	—	—
Initial Value	0	0	0	0	0	0	0	0	0	0	0	0	0	0	0	0
R/W	R	R	R	R	R	R	R	R	R	R	R	R	R/W	R	R	R

Bit	Bit Name	Initial Value	R/W	Description
31 to 4	—	All 0	R	Reserved Whenever it is read, 0 is read. The written value will be ignored.
3	SOFT_LINK	0b	R/W	Software LINK This bit is used when the LINK status is set by software. '1': Link ON (Link Up) '0': Link OFF (Link Down) <i>Note:</i> Before setting '1' to this bit, set SEL_LINK of CXR31 whether using PHY_LINK input signal, using LINK bit of RGMII-Inband Status or using LINK setting by software. Additionally, if PHY_LINK input signal is used, set the polar of PHY_LINK input signal by PHYLINKP of CXR2C.
2 to 0	—	All 0	R	Reserved When read, the initial value is read. When writing, be sure to write the initial value. Operation is not guaranteed if a value other than the initial value is written.

30.4.2.21 Mac Address register 1 (CXR24)

CXR24 set the universal MAC address (upper 32 bits).

Write restrictions:

Rewriting this register is prohibited when 1 is set to CXR20_bit 5 or 6.

Bit	31	30	29	28	27	26	25	24	23	22	21	20	19	18	17	16
	UMADR[31:16]															
Initial Value	0	0	0	0	0	0	0	0	0	0	0	0	0	0	0	0
R/W	R/W	R/W	R/W	R/W	R/W	R/W	R/W	R/W	R/W	R/W	R/W	R/W	R/W	R/W	R/W	R/W
Bit	15	14	13	12	11	10	9	8	7	6	5	4	3	2	1	0
	UMADR[15:0]															
Initial Value	0	0	0	0	0	0	0	0	0	0	0	0	0	0	0	0
R/W	R/W	R/W	R/W	R/W	R/W	R/W	R/W	R/W	R/W	R/W	R/W	R/W	R/W	R/W	R/W	R/W

Bit	Bit Name	Initial Value	R/W	Description
31 to 0	UMADR	H'0000_0000	R/W	Upper MAC Address Upper-32bit MAC address

30.4.2.22 Mac Address register 2 (CXR25)

CXR25 set the universal MAC address (lower 16 bits).

Write restrictions:

Rewriting this register is prohibited when 1 is set to CXR20_bit 5 or 6.

Bit	31	30	29	28	27	26	25	24	23	22	21	20	19	18	17	16
	—															
Initial Value	0	0	0	0	0	0	0	0	0	0	0	0	0	0	0	0
R/W	R	R	R	R	R	R	R	R	R	R	R	R	R	R	R	R
Bit	15	14	13	12	11	10	9	8	7	6	5	4	3	2	1	0
	LMADR[15:0]															
Initial Value	0	0	0	0	0	0	0	0	0	0	0	0	0	0	0	0
R/W	R/W	R/W	R/W	R/W	R/W	R/W	R/W	R/W	R/W	R/W	R/W	R/W	R/W	R/W	R/W	R/W

Bit	Bit Name	Initial Value	R/W	Description
31 to 16	—	All 0	R	Reserved Whenever it is read, 0 is read. The written value will be ignored.
15 to 0	LMADR	H'0000	R/W	Lower MAC Address Lower-16bit MAC address

30.4.2.23 TINT1 counter register (CXR40)

CXR40 indicates the number of occurrences of TINT1.

Bit	31	30	29	28	27	26	25	24	23	22	21	20	19	18	17	16
	—	—	—	—	—	—	—	—	—	—	—	—	—	—	—	—
Initial Value	0	0	0	0	0	0	0	0	0	0	0	0	0	0	0	0
R/W	R	R	R	R	R	R	R	R	R	R	R	R	R	R	R	R
Bit	15	14	13	12	11	10	9	8	7	6	5	4	3	2	1	0
	TINT1_CNT[15:0]															
Initial Value	0	0	0	0	0	0	0	0	0	0	0	0	0	0	0	0
R/W	R/W	R/W	R/W	R/W	R/W	R/W	R/W	R/W	R/W	R/W	R/W	R/W	R/W	R/W	R/W	R/W

Bit	Bit Name	Initial Value	R/W	Description
31 to 16	—	All 0	R	Reserved Whenever it is read, 0 is read. The written value will be ignored.
15 to 0	TINT1_CNT	H'0000	R/W	TINT1 Counter Indicates the number of occurrences of TINT1. TINT1: Frame transmission timeout When CXR20_bit 26 = 1, this register is cleared to 0 when read. When CXR20_bit 26 = 0, this register is cleared to 0 when written to. (Cleared to 0 when written to, irrespective of the write data.)

30.4.2.24 TINT2 counter register (CXR41)

CXR41 indicates the number of occurrences of TINT2.

Bit	31	30	29	28	27	26	25	24	23	22	21	20	19	18	17	16
	—	—	—	—	—	—	—	—	—	—	—	—	—	—	—	—
Initial Value	0	0	0	0	0	0	0	0	0	0	0	0	0	0	0	0
R/W	R	R	R	R	R	R	R	R	R	R	R	R	R	R	R	R
Bit	15	14	13	12	11	10	9	8	7	6	5	4	3	2	1	0
	TINT2_CNT[15:0]															
Initial Value	0	0	0	0	0	0	0	0	0	0	0	0	0	0	0	0
R/W	R/W	R/W	R/W	R/W	R/W	R/W	R/W	R/W	R/W	R/W	R/W	R/W	R/W	R/W	R/W	R/W

Bit	Bit Name	Initial Value	R/W	Description
31 to 16	—	All 0	R	Reserved Whenever it is read, 0 is read. The written value will be ignored.
15 to 0	TINT2_CNT	H'0000	R/W	TINT2 Counter Indicates the number of occurrences of TINT2. TINT2: Delayed collision detection When CXR20_bit 26 = 1, this register is cleared to 0 when read. When CXR20_bit 26 = 0, this register is cleared to 0 when written to. (Cleared to 0 when written to, irrespective of the write data.)

30.4.2.25 TINT3 counter register (CXR42)

CXR42 indicates the number of occurrences of TINT3.

Bit	31	30	29	28	27	26	25	24	23	22	21	20	19	18	17	16
	—	—	—	—	—	—	—	—	—	—	—	—	—	—	—	—
Initial Value	0	0	0	0	0	0	0	0	0	0	0	0	0	0	0	0
R/W	R	R	R	R	R	R	R	R	R	R	R	R	R	R	R	R
Bit	15	14	13	12	11	10	9	8	7	6	5	4	3	2	1	0
	TINT3_CNT[15:0]															
Initial Value	0	0	0	0	0	0	0	0	0	0	0	0	0	0	0	0
R/W	R/W	R/W	R/W	R/W	R/W	R/W	R/W	R/W	R/W	R/W	R/W	R/W	R/W	R/W	R/W	R/W

Bit	Bit Name	Initial Value	R/W	Description
31 to 16	—	All 0	R	Reserved Whenever it is read, 0 is read. The written value will be ignored.
15 to 0	TINT3_CNT	H'0000	R/W	TINT3 Counter Indicates the number of occurrences of TINT3. TINT3: Transmission is terminated in error with TINT3 generated under the following conditions: Delay collision occurs at the end of transmit frame, the receive frame at the time of the collision continues until the start of next frame transmission, but does not continue until the end of the transmission. However, these conditions do not occur in normal operation.

30.4.2.26 RINT1 counter register (CXR50)

CXR50 indicates the number of occurrences of RINT1.

Bit	31	30	29	28	27	26	25	24	23	22	21	20	19	18	17	16
	—	—	—	—	—	—	—	—	—	—	—	—	—	—	—	—
Initial Value	0	0	0	0	0	0	0	0	0	0	0	0	0	0	0	0
R/W	R	R	R	R	R	R	R	R	R	R	R	R	R	R	R	R
Bit	15	14	13	12	11	10	9	8	7	6	5	4	3	2	1	0
	RINT1_CNT[15:0]															
Initial Value	0	0	0	0	0	0	0	0	0	0	0	0	0	0	0	0
R/W	R/W	R/W	R/W	R/W	R/W	R/W	R/W	R/W	R/W	R/W	R/W	R/W	R/W	R/W	R/W	R/W

Bit	Bit Name	Initial Value	R/W	Description
31 to 16	—	All 0	R	Reserved Whenever it is read, 0 is read. The written value will be ignored.
15 to 0	RINT1_CNT	H'0000	R/W	RINT1 Counter Indicates the number of occurrences of RINT1. RINT1: Receive frame CRC error When CXR20_bit 26 = 1, this register is cleared to 0 when read. When CXR20_bit 26 = 0, this register is cleared to 0 when written to. (Cleared to 0 when written to, irrespective of the write data.)

30.4.2.27 RINT2 counter register (CXR51)

CXR51 indicates the number of occurrences of RINT2.

Bit	31	30	29	28	27	26	25	24	23	22	21	20	19	18	17	16
	—	—	—	—	—	—	—	—	—	—	—	—	—	—	—	—
Initial Value	0	0	0	0	0	0	0	0	0	0	0	0	0	0	0	0
R/W	R	R	R	R	R	R	R	R	R	R	R	R	R	R	R	R
Bit	15	14	13	12	11	10	9	8	7	6	5	4	3	2	1	0
	RINT2_CNT[15:0]															
Initial Value	0	0	0	0	0	0	0	0	0	0	0	0	0	0	0	0
R/W	R/W	R/W	R/W	R/W	R/W	R/W	R/W	R/W	R/W	R/W	R/W	R/W	R/W	R/W	R/W	R/W

Bit	Bit Name	Initial Value	R/W	Description
31 to 16	—	All 0	R	Reserved Whenever it is read, 0 is read. The written value will be ignored.
15 to 0	RINT2_CNT	H'0000	R/W	RINT2 Counter Indicates the number of occurrences of RINT2. RINT2: Frame reception error When CXR20_bit 26 = 1, this register is cleared to 0 when read. When CXR20_bit 26 = 0, this register is cleared to 0 when written to. (Cleared to 0 when written to, irrespective of the write data.)

30.4.2.28 RINT3 counter register (CXR52)

CXR52 indicates the number of occurrences of RINT3.

Bit	31	30	29	28	27	26	25	24	23	22	21	20	19	18	17	16
	—	—	—	—	—	—	—	—	—	—	—	—	—	—	—	—
Initial Value	0	0	0	0	0	0	0	0	0	0	0	0	0	0	0	0
R/W	R	R	R	R	R	R	R	R	R	R	R	R	R	R	R	R
Bit	15	14	13	12	11	10	9	8	7	6	5	4	3	2	1	0
	RINT3_CNT[15:0]															
Initial Value	0	0	0	0	0	0	0	0	0	0	0	0	0	0	0	0
R/W	R/W	R/W	R/W	R/W	R/W	R/W	R/W	R/W	R/W	R/W	R/W	R/W	R/W	R/W	R/W	R/W

Bit	Bit Name	Initial Value	R/W	Description
31 to 16	—	All 0	R	Reserved Whenever it is read, 0 is read. The written value will be ignored.
15 to 0	RINT3_CNT	H'0000	R/W	RINT3 Counter Indicates the number of occurrences of RINT3. RINT3: Erroneous frame length (less than 64 bytes frame was received.) When CXR20_bit 26 = 1, this register is cleared to 0 when read. When CXR20_bit 26 = 0, this register is cleared to 0 when written to. (Cleared to 0 when written to, irrespective of the write data.)

30.4.2.29 RINT4 counter register (CXR53)

CXR53 indicates the number of occurrences of RINT4.

Bit	31	30	29	28	27	26	25	24	23	22	21	20	19	18	17	16
	—	—	—	—	—	—	—	—	—	—	—	—	—	—	—	—
Initial Value	0	0	0	0	0	0	0	0	0	0	0	0	0	0	0	0
R/W	R	R	R	R	R	R	R	R	R	R	R	R	R	R	R	R
Bit	15	14	13	12	11	10	9	8	7	6	5	4	3	2	1	0
	RINT4_CNT[15:0]															
Initial Value	0	0	0	0	0	0	0	0	0	0	0	0	0	0	0	0
R/W	R/W	R/W	R/W	R/W	R/W	R/W	R/W	R/W	R/W	R/W	R/W	R/W	R/W	R/W	R/W	R/W

Bit	Bit Name	Initial Value	R/W	Description
31 to 16	—	All 0	R	Reserved Whenever it is read, 0 is read. The written value will be ignored.
15 to 0	RINT4_CNT	H'0000	R/W	RINT4 Counter Indicates the number of occurrences of RINT4. RINT4: Erroneous frame length {A frame longer than the maximum frame length was received. Maximum frame length (including CRC) can be specified using the LEN_LMT field in the CXR2A register.} When CXR20_bit 26 = 1, this register is cleared to 0 when read. When CXR20_bit 26 = 0, this register is cleared to 0 when written to. (Cleared to 0 when written to, irrespective of the write data.)

30.4.2.30 RINT5 counter register (CXR54)

CXR54 indicates the number of occurrences of RINT5.

Bit	31	30	29	28	27	26	25	24	23	22	21	20	19	18	17	16
	—	—	—	—	—	—	—	—	—	—	—	—	—	—	—	—
Initial Value	0	0	0	0	0	0	0	0	0	0	0	0	0	0	0	0
R/W	R	R	R	R	R	R	R	R	R	R	R	R	R	R	R	R
Bit	15	14	13	12	11	10	9	8	7	6	5	4	3	2	1	0
	RINT5_CNT[15:0]															
Initial Value	0	0	0	0	0	0	0	0	0	0	0	0	0	0	0	0
R/W	R/W	R/W	R/W	R/W	R/W	R/W	R/W	R/W	R/W	R/W	R/W	R/W	R/W	R/W	R/W	R/W

Bit	Bit Name	Initial Value	R/W	Description
31 to 16	—	All 0	R	Reserved Whenever it is read, 0 is read. The written value will be ignored.
15 to 0	RINT5_CNT	H'0000	R/W	RINT5 Counter Indicates the number of occurrences of RINT5. RINT5: Fractional bit error When CXR20_bit 26 = 1, this register is cleared to 0 when read. When CXR20_bit 26 = 0, this register is cleared to 0 when written to. (Cleared to 0 when written to, irrespective of the write data)

30.4.2.31 RINT6 counter register (CXR55)

CXR55 indicates the number of occurrences of RINT6.

Bit	31	30	29	28	27	26	25	24	23	22	21	20	19	18	17	16
	—	—	—	—	—	—	—	—	—	—	—	—	—	—	—	—
Initial Value	0	0	0	0	0	0	0	0	0	0	0	0	0	0	0	0
R/W	R	R	R	R	R	R	R	R	R	R	R	R	R	R	R	R
Bit	15	14	13	12	11	10	9	8	7	6	5	4	3	2	1	0
	RINT6_CNT[15:0]															
Initial Value	0	0	0	0	0	0	0	0	0	0	0	0	0	0	0	0
R/W	R/W	R/W	R/W	R/W	R/W	R/W	R/W	R/W	R/W	R/W	R/W	R/W	R/W	R/W	R/W	R/W

Bit	Bit Name	Initial Value	R/W	Description
31 to 16	—	All 0	R	Reserved Whenever it is read, 0 is read. The written value will be ignored.
15 to 0	RINT6_CNT	H'0000	R/W	RINT6 Counter Indicates the number of occurrences of RINT6. RINT6: Carrier extension lost When CXR20_bit 26 = 1, this register is cleared to 0 when read. When CXR20_bit 26 = 0, this register is cleared to 0 when written to. (Cleared to 0 when written to, irrespective of the write data.)

30.4.2.32 RINT7 counter register (CXR56)

CXR56 indicates the number of occurrences of RINT7.

Bit	31	30	29	28	27	26	25	24	23	22	21	20	19	18	17	16
	—	—	—	—	—	—	—	—	—	—	—	—	—	—	—	—
Initial Value	0	0	0	0	0	0	0	0	0	0	0	0	0	0	0	0
R/W	R	R	R	R	R	R	R	R	R	R	R	R	R	R	R	R
Bit	15	14	13	12	11	10	9	8	7	6	5	4	3	2	1	0
	RINT7_CNT[15:0]															
Initial Value	0	0	0	0	0	0	0	0	0	0	0	0	0	0	0	0
R/W	R/W	R/W	R/W	R/W	R/W	R/W	R/W	R/W	R/W	R/W	R/W	R/W	R/W	R/W	R/W	R/W

Bit	Bit Name	Initial Value	R/W	Description
31 to 16	—	All 0	R	Reserved Whenever it is read, 0 is read. The written value will be ignored.
15 to 0	RINT7_CNT	H'0000	R/W	RINT7 Counter Indicates the number of occurrences of RINT7. RINT7: Carrier extension error When CXR20_bit 26 = 1, this register is cleared to 0 when read. When CXR20_bit 26 = 0, this register is cleared to 0 when written to. (Cleared to 0 when written to, irrespective of the write data.)

30.4.2.33 RINT8 counter register (CXR57)

CXR57 indicates the number of occurrences of RINT8.

Bit	31	30	29	28	27	26	25	24	23	22	21	20	19	18	17	16
	—	—	—	—	—	—	—	—	—	—	—	—	—	—	—	—
Initial Value	0	0	0	0	0	0	0	0	0	0	0	0	0	0	0	0
R/W	R	R	R	R	R	R	R	R	R	R	R	R	R	R	R	R
Bit	15	14	13	12	11	10	9	8	7	6	5	4	3	2	1	0
	RINT8_CNT[15:0]															
Initial Value	0	0	0	0	0	0	0	0	0	0	0	0	0	0	0	0
R/W	R/W	R/W	R/W	R/W	R/W	R/W	R/W	R/W	R/W	R/W	R/W	R/W	R/W	R/W	R/W	R/W

Bit	Bit Name	Initial Value	R/W	Description
31 to 16	—	All 0	R	Reserved Whenever it is read, 0 is read. The written value will be ignored.
15 to 0	RINT8_CNT	H'0000	R/W	RINT8 Counter Indicates the number of occurrences of RINT8. RINT8: Multicast frame received When CXR20_bit 26 = 1, this register is cleared to 0 when read. When CXR20_bit 26 = 0, this register is cleared to 0 when written to. (Cleared to 0 when written to, irrespective of the write data.)

30.4.2.34 MDIO status register (MDIOSTS)

MDIOSTS indicates the status of PHY register access (MDIO access).

Write restrictions:

Write disabled

Bit	31	30	29	28	27	26	25	24	23	22	21	20	19	18	17	16
	—	—	—	—	—	—	—	—	—	—	—	—	—	—	—	—
Initial Value	0	0	0	0	0	0	0	0	0	0	0	0	0	0	0	0
R/W	R	R	R	R	R	R	R	R	R	R	R	R	R	R	R	R
Bit	15	14	13	12	11	10	9	8	7	6	5	4	3	2	1	0
	—	—	—	—	—	—	—	—	—	—	—	—	—	—	—	BSY
Initial Value	0	0	0	0	0	0	0	0	0	0	0	0	0	0	0	0
R/W	R	R	R	R	R	R	R	R	R	R	R	R	R	R	R	R

Bit	Bit Name	Initial Value	R/W	Description
31 to 1	—	All 0	R	Reserved Whenever it is read, 0 is read. The written value will be ignored.
0	BSY	0b	R	PHY register access Busy flag 0: Access enabled 1: Busy Do not write to MDIOCMD, MDIOADR, MDIODAT or MDIOMOD registers when this bit is 1.

30.4.2.35 MDIO command register (MDIOCMD)

MDIOCMD specifies the commands for PHY register access (MDIO access).

Write restrictions:

Do not write to this register when the BSY bit in the MDIOSTS register is 1.

Bit	31	30	29	28	27	26	25	24	23	22	21	20	19	18	17	16
	—	—	—	—	—	—	—	—	—	—	—	—	—	—	—	—
Initial Value	0	0	0	0	0	0	0	0	0	0	0	0	0	0	0	0
R/W	R	R	R	R	R	R	R	R	R	R	R	R	R	R	R	R
Bit	15	14	13	12	11	10	9	8	7	6	5	4	3	2	1	0
	—	—	—	—	—	—	—	—	—	—	—	—	—	—	OP[1:0]	
Initial Value	0	0	0	0	0	0	0	0	0	0	0	0	0	0	0	0
R/W	R	R	R	R	R	R	R	R	R	R	R	R	R	R	R/W	R/W

Bit	Bit Name	Initial Value	R/W	Description
31 to 2	—	All 0	R	Reserved Whenever it is read, 0 is read. The written value will be ignored.
1 to 0	OP	00b	R/W	Operation Code for PHY register access 00: Setting prohibited 01: WRITE 10: READ 11: Setting prohibited

30.4.2.36 MDIO address register (MDIOADR)

MDIOADR specifies PHY address and PHY register address.

Bit	31	30	29	28	27	26	25	24	23	22	21	20	19	18	17	16
	—	—	—	—	—	—	—	—	—	—	—	—	—	—	—	—
Initial Value	0	0	0	0	0	0	0	0	0	0	0	0	0	0	0	0
R/W	R	R	R	R	R	R	R	R	R	R	R	R	R	R	R	R
Bit	15	14	13	12	11	10	9	8	7	6	5	4	3	2	1	0
	—	—	—	—	—	—	A[9:5]					A[4:0]				
Initial Value	0	0	0	0	0	0	0	0	0	0	0	0	0	0	0	0
R/W	R	R	R	R	R	R	R/W	R/W	R/W	R/W	R/W	R/W	R/W	R/W	R/W	R/W

Bit	Bit Name	Initial Value	R/W	Description
31 to 10	—	All 0	R	Reserved Whenever it is read, 0 is read. The written value will be ignored.
9 to 5	A[9:5]	00000b	R/W	PHY address 5 bits
4 to 0	A[4:0]	00000b	R/W	PHY register address 5 bits

30.4.2.37 MDIO data register (MDIODAT)

MDIODAT specifies PHY write data and indicates read data.

Write restrictions:

Do not write to this register when the BSY bit in the MDIOSTS register is 1.

Bit	31	30	29	28	27	26	25	24	23	22	21	20	19	18	17	16
	—	—	—	—	—	—	—	—	—	—	—	—	—	—	—	—
Initial Value	0	0	0	0	0	0	0	0	0	0	0	0	0	0	0	0
R/W	R	R	R	R	R	R	R	R	R	R	R	R	R	R	R	R
Bit	15	14	13	12	11	10	9	8	7	6	5	4	3	2	1	0
	D[15:0]															
Initial Value	0	0	0	0	0	0	0	0	0	0	0	0	0	0	0	0
R/W	R/W	R/W	R/W	R/W	R/W	R/W	R/W	R/W	R/W	R/W	R/W	R/W	R/W	R/W	R/W	R/W

Bit	Bit Name	Initial Value	R/W	Description
31 to 16	—	All 0	R	Reserved Whenever it is read, 0 is read. The written value will be ignored.
15 to 0	D[15:0]	H'0000	R/W	PHY register data When writing: Write data When reading: Read data

30.4.2.38 MDIO mode register (MDIOMOD)

MDIOMOD sets the operating mode of the MDIO controller.

Write restrictions:

Writing to this bit is prohibited during PHY register access.

Bit	31	30	29	28	27	26	25	24	23	22	21	20	19	18	17	16
	SEL_M DIO_N	—	—	—	—	—	—	—	—	—	—	—	—	—	—	—
Initial Value	1	0	0	0	0	0	0	0	0	0	0	0	0	0	0	0
R/W	R/W	R	R	R	R	R	R	R	R	R	R	R	R	R	R	R
Bit	15	14	13	12	11	10	9	8	7	6	5	4	3	2	1	0
	—	—	—	—	—	—	—	—	CYC_OCLK[7:0]							
Initial Value	0	0	0	0	0	0	0	0	1	1	1	1	1	1	1	1
R/W	R	R	R	R	R	R	R	R	R/W	R/W	R/W	R/W	R/W	R/W	R/W	R/W

Bit	Bit Name	Initial Value	R/W	Description
31	SEL_MDIO_N	1b	R/W	Selection for PHY register access (MDIO access selection) 0: Uses MDIO controller for PHY register access. 1: Uses CXR23 register for PHY register access. (Initial value)
31 to 8	—	All 0	R	Reserved Whenever it is read, 0 is read. The written value will be ignored.
7 to 0	CYC_OCLK	H'FF	R/W	MDC (MDIO control clock) half cycle (number of cycles for system clock) H'00: 7 cycles H'01: 7 cycles ... H'06: 7 cycles H'07: 8 cycles H'08: 9 cycles H'09: 10 cycles ... H'FE: 255 cycles H'FF: 256 cycles (Initial value) MDC half cycle should be set to be 200 ns or more. (Calculation example) 27 cycles at a 133-MHz Clock (1 cyc=7.5 ns), 200 ns or more -> Setting value is H'1A (26d) $7.5 \times 27 = 202.5 \geq 200$ (Setting example) //66.66 MHz (15 ns): Setting value \geq H'0D (13d) (14 cyc \times 15 ns = 210 ns) //133.3 MHz (7.5 ns): Setting value \geq H'1A (26d) (27 cyc \times 7.5 ns=202.5 ns) //266.6 MHz (3.75 ns): Setting value \geq H'35 (53d) (54 cyc \times 3.75 ns=202.5 ns)

30.4.2.39 Low Power Mode register 1 (LPTXMOD1)

LPTXMOD1 sets the operating mode of the Low Power Transmission.

Write restrictions:

Write to this register when the CXR20_bit6 = '0' and CXR20_bit5 = '0'. Recommended value is H'00000000 (Initial value).

Bit	31	30	29	28	27	26	25	24	23	22	21	20	19	18	17	16
	—				GCYC_TCSTOP[11:0]											
Initial Value	0	0	0	0	0	0	0	0	0	0	0	0	0	0	0	0
R/W	R	R	R	R	R/W	R/W	R/W	R/W	R/W	R/W	R/W	R/W	R/W	R/W	R/W	R/W
Bit	15	14	13	12	11	10	9	8	7	6	5	4	3	2	1	0
	—				MCYC_TCSTOP[11:0]											
Initial Value	0	0	0	0	0	0	0	0	0	0	0	0	0	0	0	0
R/W	R	R	R	R	R/W	R/W	R/W	R/W	R/W	R/W	R/W	R/W	R/W	R/W	R/W	R/W

Bit	Bit Name	Initial Value	R/W	Description
31 to 28	—	All 0	R	Reserved Whenever it is read, 0 is read. The written value will be ignored.
27 to 16	GCYC_TCSTOP	H'000	R/W	Number of minimum clock cycles until stopping RGMII TXC (1 Gbps) 0: 10 cycles (Initial value) 1 to 8: (Setting prohibited) 9: 9 cycles 10: 10 cycles 11: 11 cycles (skip the rest)
15 to 12	—	All 0	R	Reserved Whenever it is read, 0 is read. The written value will be ignored.
11 to 0	MCYC_TCSTOP	H'000	R/W	Number of minimum clock cycles until stopping RGMII TXC (100 Mbps) 0: 10 cycles (Initial value) 1 to 8: (Setting prohibited) 9: 9 cycles 10: 10 cycles 11: 11 cycles (skip the rest)

30.4.2.40 Low Power Mode register 2 (LPTXMOD2)

LPTXMOD2 sets the operating mode of the Low Power Transmission.

Write restrictions:

Write to this register when the CXR20_bit6 = '0' and CXR20_bit5 = '0'. When set '1' to this register, check the configuration of Clock stoppable of PHY is '1'.

Bit	31	30	29	28	27	26	25	24	23	22	21	20	19	18	17	16
	—	—	—	—	—	—	—	—	—	—	—	—	—	—	—	—
Initial Value	0	0	0	0	0	0	0	0	0	0	0	0	0	0	0	0
R/W	R	R	R	R	R	R	R	R	R	R	R	R	R	R	R	R
Bit	15	14	13	12	11	10	9	8	7	6	5	4	3	2	1	0
	—	—	—	—	—	—	—	—	—	—	—	MAC_T LPI_TY PE	—	—	—	STP_TX C_LPI
Initial Value	0	0	0	0	0	0	0	0	0	0	0	0	0	0	0	0
R/W	R	R	R	R	R	R	R	R	R	R	R	R/W	R	R	R	R/W

Bit	Bit Name	Initial Value	R/W	Description
31 to 5	—	All 0	R	Reserved Whenever it is read, 0 is read. The written value will be ignored.
4	MAC_TLPI_T YPE	0b	R/W	Transmission LPI Operation Type of MAC '1': MAC TX LPI Slave Mode E-MAC does not transmit LPI code during LPI period. But using LPI Wakeup parameters (LPTXGTH3/LPTXMTH3) to make the delay time of transmitting such as for PAUSE Frame. When making PHY control the operation of LPI (Low Power Idle), set '1' to this bit. '0': MAC TX LPI Master Mode E-MAC controls the operation of LPI. (Initial value)
3 to 1	—	All 0	R	Reserved Whenever it is read, 0 is read. The written value will be ignored.
0	STP_TXC_LP I	0b	R/W	Setting of stopping LPI TXC (this bit is used only RGMII Mode) '1': The clock for RGMII transmitting (fet_miitx_gtx_clk) is stopped during output of LPI code. '0': The clock for RGMII transmitting (fet_miitx_gtx_clk) is not stopped during output of LPI code. (Initial value) Set '1' to this bit when TX Clock stop capable (Note1) of PHY is '1' <i>Note 1.</i> See the Bit 6 Clock Stop Capable (MAC may stop clock during LPI) of PCS Status register in PHY MMD extended register (MMD address 3, REG address 1) <i>Note 2.</i> In the case of CCC.ERCS = 1 (The "clk_miitx_gtx_refclk" stop function is enable), even if this bit was set to '0', the clock for RGMII transmitting (fet_miitx_gtx_clk) is stopped during the stopping period of "clk_miitx_gtx_refclk". Because "fet_miitx_gtx_clk" is generated from "clk_miitx_gtx_refclk".

30.4.2.41 RGMII Low Power parameter register 1 (LPTXGTH1)

LPTXGTH1 sets the change timing to Low Power Idle Transmission Mode at 1 Gbps.

Write restrictions:

Write to this register when the CXR20_bit6 = '0', CXR20_bit5 = '0'. Recommended value is H'00000000 (Initial value).

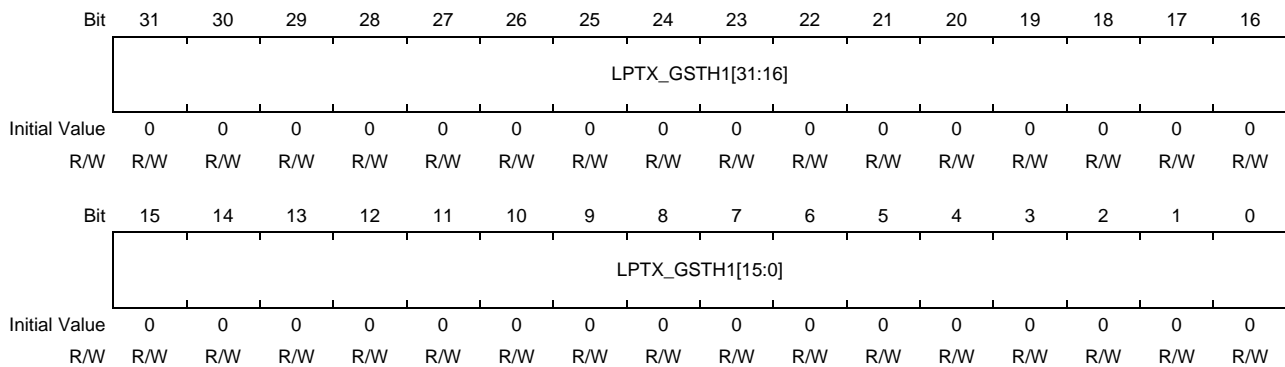

Bit	Bit Name	Initial Value	R/W	Description
31 to 0	LPTX_GSTH1	H'0000_0000	R/W	<p>Threshold value of LPI code transmission standby status (1 Gbps) (Unit is 32 ns)</p> <p>0: (Initial value) When MAC does not receive transmission request during 1 ms, MAC starts transmitting LPI code.</p> <p>1 to 7: Setting prohibited</p> <p>...</p> <p>32: When MAC does not receive transmission request during 1024 ns. MAC starts transmitting LPI code.</p> <p>...</p> <p>31250: When MAC does not receive transmission request during 1 ms, MAC starts transmitting LPI code.</p> <p>...</p> <p>(skip the rest)</p> <p><i>Note:</i> This value is used by internal logic and does not mean indicating accurate time on PHY IF.</p>

30.4.2.42 RGMII Low Power parameter register 2 (LPTXGTH2)

LPTXGTH2 sets the change timing to Low Power Idle Transmission Mode after enabled function of transmitting LPI code at 1Gbps.

Write restrictions:

Write to this register when the CXR20_bit6 = '0', CXR20_bit5 = '0'. Recommended value is H'00000000 (Initial value).

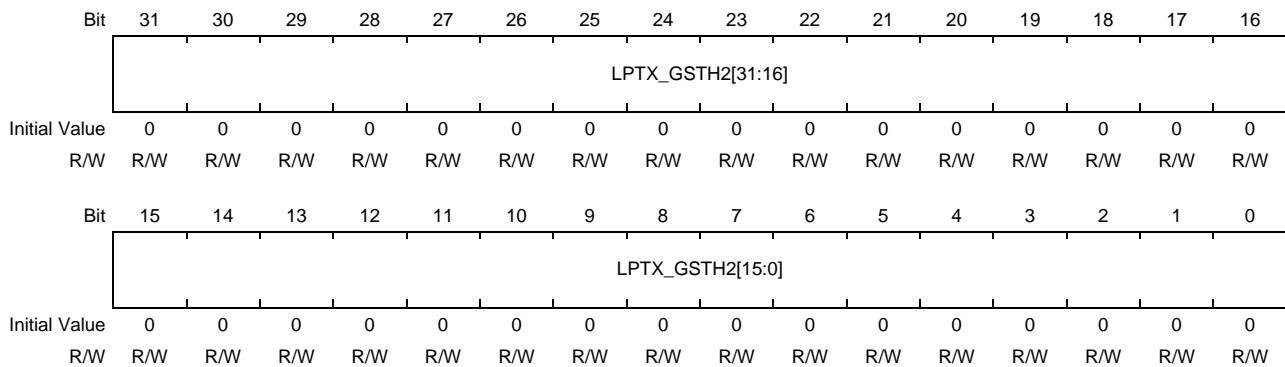

Bit	Bit Name	Initial Value	R/W	Description
31 to 0	LPTX_GSTH 2	H'0000_0000	R/W	<p>Threshold value of starting LPI code transmission standby status (1 Gbps) (Unit is 32 ns)</p> <p>0: (Initial value) MAC will be ready for transmitting LPI code after 1.01 s later from LinkUp/LPM bit of CXR20 is set to '1'.</p> <p>1 to 7: Setting prohibited</p> <p>...</p> <p>32: MAC will be ready for transmitting LPI code after 1024 ns later from LinkUp/LPM bit of CXR20 is set to '1'.</p> <p>...</p> <p>31250000: MAC will be ready for transmitting LPI code after 1 s later from LinkUp/LPM bit of CXR20 is set to '1'.</p> <p>...</p> <p>31562500: MAC will be ready for transmitting LPI code after 1.01 s later from LinkUp/LPM bit of CXR20 is set to '1'.</p> <p>...</p> <p>100000000: MAC will be ready for transmitting LPI code after 3.2 s later from LinkUp/LPM bit of CXR20 is set to '1'.</p> <p>...</p> <p>(skip the rest)</p> <p><i>Note:</i> This value is used by internal logic and does not mean indicating accurate time on PHY IF.</p> <p>Recommended setting value In the standard, the behavior of PHY is undefined if PHY receives LPI code within 1 s after Link Up. Therefore, the recommended value was determined as 1.01 s. (1 s plus 1% margin) The following is reason why "LPM bit of CXR20 is set to '1'" was include to the condition. Internal Clock (32 ns:1 Gbps, 320 ns:100 Mbps) is used to measure the time after Link Up. But Internal Clock will change during transmission rate is un-determined. So, it is difficult to measure the time after Link Up exactly. Therefore, "LPM bit of CXR20 is set to '1'" was include to the condition as determined point of transmission rate of Low Power Mode.</p>

30.4.2.43 RGMII Low Power parameter register 3 (LPTXGTH3)

LPTXGTH3 sets the operation return from Low Power Idle Transmission Mode at 1 Gbps.

Write restrictions:

Write to this register when the CXR20_bit6 = '0', CXR20_bit5 = '0'. Recommended value is H'00000000 (Initial value). Do not set 262144 (H'00040000) or more to this register.

Bit	31	30	29	28	27	26	25	24	23	22	21	20	19	18	17	16
LPTX_GRTH[31:16]																
Initial Value	0	0	0	0	0	0	0	0	0	0	0	0	0	0	0	0
R/W	R/W	R/W	R/W	R/W	R/W	R/W	R/W	R/W	R/W	R/W	R/W	R/W	R/W	R/W	R/W	R/W
Bit	15	14	13	12	11	10	9	8	7	6	5	4	3	2	1	0
LPTX_GRTH[15:0]																
Initial Value	0	0	0	0	0	0	0	0	0	0	0	0	0	0	0	0
R/W	R/W	R/W	R/W	R/W	R/W	R/W	R/W	R/W	R/W	R/W	R/W	R/W	R/W	R/W	R/W	R/W

Bit	Bit Name	Initial Value	R/W	Description
31 to 0	LPTX_GRTH	H'0000_000	R/W	<p>Transmission Low Power resume time (1 Gbps) (Unit 32 ns)</p> <p>0: (Initial value) After received transmit request, MAC transmits Normal Idle code during 17.184 us. And then MAC returns to Normal Mode from Low Power Mode.</p> <p>1 to 7: Setting prohibited</p> <p>...</p> <p>32: After received transmit request, MAC transmits Normal Idle code during 1024 ns And then MAC returns to Normal Mode from Low Power Mode.</p> <p>...</p> <p>516: After received transmit request, MAC transmits Normal Idle code during 16.512 us. And then MAC returns to Normal Mode from Low Power Mode.</p> <p>521: After received transmit request, MAC transmits Normal Idle code during 16.672 us. And then MAC returns to Normal Mode from Low Power Mode.</p> <p>532: After received transmit request, MAC transmits Normal Idle code during 17.024 us. And then MAC returns to Normal Mode from Low Power Mode.</p> <p>537: After received transmit request, MAC transmits Normal Idle code during 17.184 us. And then MAC returns to Normal Mode from Low Power Mode.</p> <p>...</p> <p>1000: After received transmit request, MAC transmits Normal Idle code during 17.184 us. And then MAC returns to Normal Mode from Low Power Mode.</p> <p>...</p> <p>262144 or more: Reserved (Setting prohibited) (skip the rest)</p> <p><i>Note:</i> This value is used by internal logic and does not mean indicating accurate time on PHY IF.</p> <p>Recommended setting value</p> <p>The basic value of this field is LPI WakeUp Time ($T_{w_sys_tx}$) with 1% margin. In the case of 1000BASE-T, $T_{w_sys_tx}$ is 16.5 us. But some of PHY needs 1 us for Wakeup Time. Therefore, recommended value was determined as 17.184 us.</p> <p>The setting value of this field will be the overhead time return from Low Power Mode. Do not set the value will be under the 16.5 us (Minimum Wakeup Time which is defined by standard) to this field.</p> <p>In addition, if PHY has the LPI transmission control function, PHY also make overhead time same as Wake-Up Time.</p>

30.4.2.44 RGMII Low Power parameter register 4 (LPTXGTH4)

LPTXGTH4 sets the minimum period for Low Power Idle Transmission Mode at 1 Gbps.

Write restrictions:

Write to this register when the CXR20_bit6 = '0', CXR20_bit5 = '0'. Recommended value is H'00000000 (Initial value).

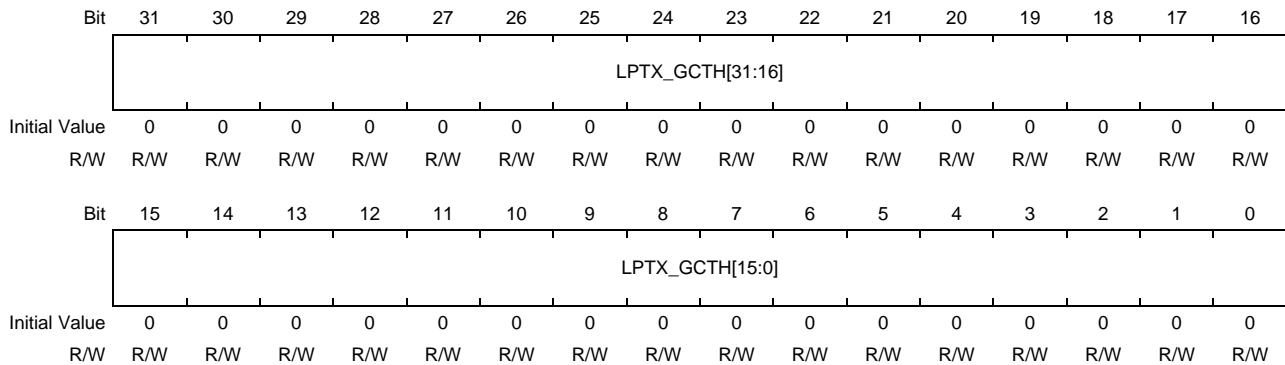

Bit	Bit Name	Initial Value	R/W	Description
31 to 0	LPTX_GCTH	H'0000_0000	R/W	<p>Minimum Transmission Low Power time (1 Gbps) (Unit is 32 ns)</p> <p>0: (Initial value) After started to output Transmission LPI code, MAC will continue to output Transmission LPI code at least 1024 ns.</p> <p>1 to 7: Setting prohibited</p> <p>8: After started to output Transmission LPI code, MAC will continue to output Transmission LPI code at least 256 ns.</p> <p>...</p> <p>32: After started to output Transmission LPI code, MAC will continue to output Transmission LPI code at least 1024 ns.</p> <p>...</p> <p>6469: After started to output Transmission LPI code, MAC will continue to output Transmission LPI code at least 207.008 us (Sleep Time + α).</p> <p>...</p> <p>10000: After started to output Transmission LPI code, MAC will continue to output Transmission LPI code at least 320 us.</p> <p>...</p> <p>(skip the rest)</p> <p><i>Note:</i> This value is used by internal logic and does not mean indicating accurate time on PHY IF.</p> <p>Recommended setting value Recommended value of this field is 1 us (1024 ns) for 1000BASE-T. This value based on followings: [1] This value should be sufficiency longer than 72 ns [2] This value should be sufficiency shorter than Wake Up Time (16.5 us). And selected the value which is close to geometric mean of [1] and [2].</p>

30.4.2.45 MII Low Power parameter register 1 (LPTXMTH1)

LPTXMTH1 sets the change timing to Low Power Idle Transmission Mode at 100 Mbps.

Write restrictions:

Write to this register when the CXR20_bit6 = '0', CXR20_bit5 = '0'. Recommended value is H'00000000 (Initial value).

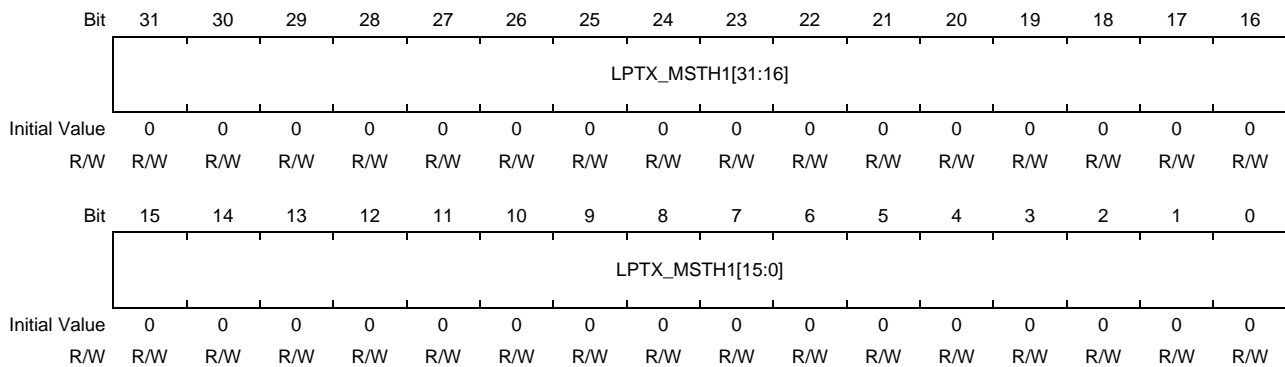

Bit	Bit Name	Initial Value	R/W	Description
31 to 0	LPTX_MSTH1	H'0000_0000	R/W	<p>Threshold value of LPI code transmission standby status (100 Mbps) (Unit is 320 ns)</p> <p>0: (Initial value) When MAC does not receive transmission request during 1 ms, MAC starts transmitting LPI code.</p> <p>1 to 7: Setting prohibited</p> <p>8: When MAC does not receive transmission request during 10240 ns, MAC starts transmitting LPI code.</p> <p>...</p> <p>3125: When MAC does not receive transmission request during 1 ms, MAC starts transmitting LPI code.</p> <p>...</p> <p>(skip the rest)</p> <p><i>Note:</i> This value is used by internal logic and does not mean indicating accurate time on PHY IF.</p>

30.4.2.46 MII Low Power parameter register 2 (LPTXMTH2)

LPTXMTH2 sets the change timing to Low Power Idle Transmission Mode after enabled function of transmitting LPI code at 100 Mbps.

Write restrictions:

Write to this register when the CXR20_bit6 = '0', CXR20_bit5 = '0'. Recommended value is H'00000000 (Initial value).

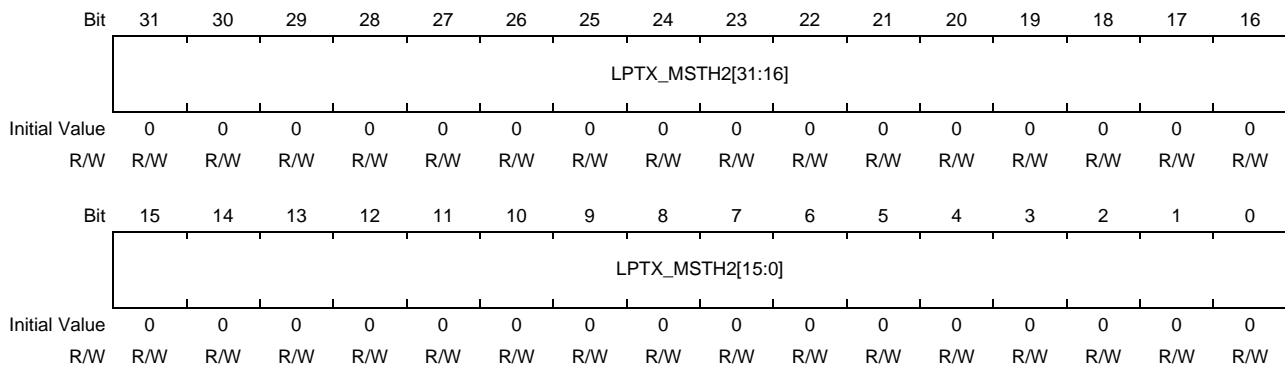

Bit	Bit Name	Initial Value	R/W	Description
31 to 0	LPTX_MSTH2	H'0000_000	R/W	<p>Threshold value of starting LPI code transmission standby status (100 Mbps) (Unit is 320 ns)</p> <p>0: (Initial value) MAC will be ready for transmitting LPI code after 1.01 s later from Link Up or LPM bit of CXR20 is set to '1'.</p> <p>1 to 7: Setting prohibited</p> <p>...</p> <p>32: MAC will be ready for transmitting LPI code after 10240 ns later from LinkUp/LPM bit of CXR20 is set to '1'.</p> <p>...</p> <p>3125000: MAC will be ready for transmitting LPI code after 1.0 s later from LinkUp/LPM bit of CXR20 is set to '1'.</p> <p>...</p> <p>3156250: MAC will be ready for transmitting LPI code after 1.01 s from LinkUp/LPM bit of CXR20 is set to '1'.</p> <p>...</p> <p>10000000: MAC will be ready for transmitting LPI code after 3.2 s later from LinkUp/LPM bit of CXR20 is set to '1'.</p> <p>...</p> <p>(skip the rest)</p> <p><i>Note:</i> This value is used by internal logic and does not mean indicating accurate time on PHY IF.</p> <p>Recommended setting value</p> <p>In the standard, the behavior of PHY is undefined if PHY receives LPI code within 1 s after Link Up. Therefore, the recommended value was determined as 1.01 s. (1 s plus 1% margin)</p> <p>The following is reason why "LPM bit of CXR20 is set to '1'" was include to the condition.</p> <p>Internal Clock (32 ns:1 Gbps, 320 ns:100 Mbps) is used to measure the time after Link Up. But Internal Clock will change during transmission rate is un-determined. So, it is difficult to measure the time after Link Up exactly.</p> <p>Therefore, "LPM bit of CXR20 is set to '1'" was include to the condition as determined point of transmission rate of Low Power Mode.</p>

30.4.2.47 MII Low Power parameter register 3 (LPTXMTH3)

LPTXMTH3 sets the operation return from Low Power Idle Transmission Mode at 100 Mbps.

Write restrictions:

Write to this register when the CXR20_bit6 = '0', CXR20_bit5 = '0'. Recommended value is H'00000000 (Initial value). Do not set 262144 (H'00040000) or more to this register.

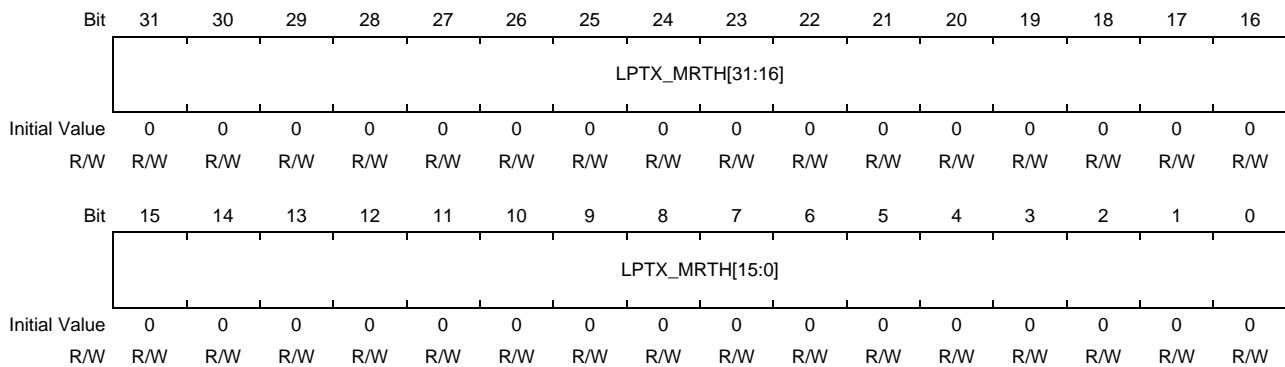

Bit	Bit Name	Initial Value	R/W	Description
31 to 0	LPTX_MRTH	H'0000_000	R/W	<p>Transmission Low Power resume time (100 Mbps) (Unit 320 ns)</p> <p>0: (Initial value) After received transmit request, MAC transmits Normal Idle code during 30.40 us. And then MAC returns to Normal Mode from Low Power Mode.</p> <p>1 to 7: Setting prohibited</p> <p>...</p> <p>32: After received transmit request, MAC transmits Normal Idle code during 10240 ns And then MAC returns to Normal Mode from Low Power Mode.</p> <p>...</p> <p>94: After received transmit request, MAC transmits Normal Idle code during 30.08 us And then MAC returns to Normal Mode from Low Power Mode.</p> <p>95: After received transmit request, MAC transmits Normal Idle code during 30.40 us And then MAC returns to Normal Mode from Low Power Mode.</p> <p>...</p> <p>262144 or more: Reserved (Setting prohibited)</p> <p><i>Note:</i> This value is used by internal logic and does not mean indicating accurate time on PHY IF.</p> <p>Recommended setting value The basic value of this field is LPI WakeUp Time (Tw_sys_tx) with 1% margin. In the case of 100BASE-TX, Tw_sys_tx is 30 us. Therefore, recommended value was determined as 30.4 us. The setting value of this field will be the overhead time return from Low Power Mode. Do not set the value under the 30 us (Minimum Wakeup Time which is defined by standard) to this field.</p>

30.4.2.48 MII Low Power parameter register 4 (LPTXMTH4)

LPTXMTH4 sets the minimum period for Low Power Idle Transmission Mode at 100 Mbps

Write restrictions:

Write to this register when the CXR20_bit6 = '0', CXR20_bit5 = '0'. Recommended value is H'00000000 (Initial value).

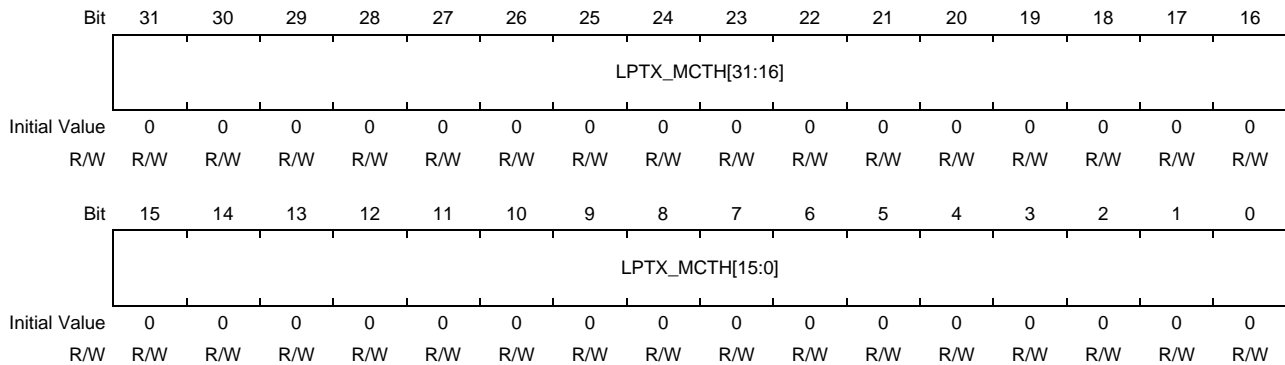

Bit	Bit Name	Initial Value	R/W	Description
31 to 0	LPTX_MCTH	H'0000_0000	R/W	<p>Minimum Transmission Low Power time (100 Mbps) (Unit is 320 ns)</p> <p>0: (Initial value) After started to output Transmission LPI code, MAC will continue to output Transmission LPI code at least 3200 ns.</p> <p>1 to 7: Setting prohibited</p> <p>8: After started to output Transmission LPI code, MAC will continue to output Transmission LPI code at least 2560 ns.</p> <p>...</p> <p>10: After started to output Transmission LPI code, MAC will continue to output Transmission LPI code at least 3200 ns.</p> <p>...</p> <p>844: After started to output Transmission LPI code, MAC will continue to output Transmission LPI code at least 270.08 us (Sleep Time+α).</p> <p>...</p> <p>1000: After started to output Transmission LPI code, MAC will continue to output Transmission LPI code at least 320 us.</p> <p>...</p> <p>(skip the rest)</p> <p><i>Note:</i> This value is used by internal logic and doesn't mean indicating accurate time on PHY IF.</p> <p>Recommended setting value Recommended value of this field is 3.2 us (3200 ns) for 100BASE-TX. This value based on followings: [1] his value should be sufficiency longer than 360 ns [2] This value should be sufficiency shorter than Wake Up Time (30 us). And selected the value which is close to geometric mean of [1] and [2].</p>

30.4.3 TOE Registers

30.4.3.1 Checksum operating mode register (CSR0)

Bit	31	30	29	28	27	26	25	24	23	22	21	20	19	18	17	16
	—	—	—	—	—	—	—	—	—	—	—	—	—	—	FIFOCAP[1:0]	
Initial Value	0	0	0	0	0	0	0	0	0	0	0	0	0	0	0	0
R/W	R	R	R	R	R	R	R	R	R	R	R	R	R	R	R/W	R/W
Bit	15	14	13	12	11	10	9	8	7	6	5	4	3	2	1	0
	—	—	—	—	—	—	RBP	TBP	—	—	RPE	TPE	—	—	—	CCM
Initial Value	0	0	0	0	0	0	0	0	0	0	0	0	0	0	0	0
R/W	R	R	R	R	R	R	R/W	R/W	R	R	R/W	R/W	R	R	R	R/W

Bit	Bit Name	Initial Value	R/W	Description
31 to 18	—	All 0	R	Reserved Whenever it is read, 0 is read. The written value will be ignored.
17 to 16	FIFOCAP	00b	R/W	FIFO CAPACITY TOE FIFO Capacity 00b: 2 Kbyte (512 Word × 32bit) 01b: 4 Kbyte (1024 Word × 32bit) 10b: 8 Kbyte (2048 Word × 32bit) 11b: 16 Kbyte (4096 Word × 32bit) Write to this field when TPE is '0'.
15 to 10	—	All 0	R	Reserved Whenever it is read, 0 is read. The written value will be ignored.
9	RBP	0b	R/W	Receive Bypass Enable Bypass Enable of TOE Rx function. 0b: Rx Function is not bypassed. 1b: Rx Function is bypassed. (for debug) <i>Note:</i> This bit is used only for debug. Do not set 1b during normal operation. When this bit is set to "1", all Rx Functions of TOE are bypassed. Therefore, TOE sends Rx frame from E-MAC to DMAC even if RPE is '0'. Write to this bit when RPE is '0'. When this bit is set to "0", set E-MAC as CRC Pass Through Mode (CX20 RCPT = "1"). When this bit is set to "1", set E-MAC as Non-CRC Pass Through Mode (CX20 RCPT = "0").
8	TBP	0b	R/W	Transmit Bypass Enable Bypass Enable of TOE Tx Function 0b: Tx Function is not bypassed. 1b: Tx Function is bypassed (for debug) <i>Note:</i> This bit is used only for debug. Do not set 1b during normal operation. When this bit is set to "1", all Tx Functions of TOE are bypassed. Therefore, TOE sends Tx frame from DMAC to E-MAC even if TPE is '0'. Since Tx Frame does not go through TOE FIFO, there is no latency. Write to this bit when TPE is '0'.
7 to 6	—	All 0	R	Reserved Whenever it is read, 0 is read. The written value will be ignored.

Bit	Bit Name	Initial Value	R/W	Description
5	RPE	0b	R/W	<p>Receive Port Enable</p> <p>Enable of Frame Output Function to DMAC.</p> <p>0b: Output Function is disabled.</p> <p>1b: Output Function is enabled.</p> <p>When value is changed from '1' to '0' during TOE is outputting any frames, the value of this bit will be '0' after finished outputting. Therefore, '1' is read as read value during TOE is outputting frames.</p>
4	TPE	0b	R/W	<p>Transmit Port Enable</p> <p>Enable of Frame Output Function to E-MAC.</p> <p>0b: Output Function is disable.</p> <p>1b: Output Function is enabled.</p> <p>Procedure of setting '0' to this bit.</p> <p>(1) Set '0' to TPE.</p> <p>(2) Continue to read TPE until it will be read as '0'. (TPE will be '0' when TOE FIFO will be empty)</p> <p>(3) If read value is '0', procedure of setting '0' is finished.</p>
3 to 1	—	All 0	R	<p>Reserved</p> <p>Whenever it is read, 0 is read. The written value will be ignored.</p>
0	CCM	0b	R/W	<p>Counter Clear Mode</p> <p>This bit designates the clear method of Interrupt Status Counters (CSR20, CSR30, CSR31, CSR32)</p> <p>1b: When each Counter Registers are read, they are cleared to '0'.</p> <p>0b: When each Counter Registers are written any value, they are cleared to '0'.</p> <p>Write to this bit when TPE is '0' and RPE is '0'.</p>

30.4.3.2 Tx Frame Checksum Enable register (CSR1)

Bit	31	30	29	28	27	26	25	24	23	22	21	20	19	18	17	16
	—	—	—	—	TDHD	TAHD	TROUT	THOP	—	TICMP6	TUDP6	TTCP6	—	—	—	—
Initial Value	0	0	0	0	0	0	0	0	0	0	0	0	0	0	0	0
R/W	R	R	R	R	R/W	R/W	R/W	R/W	R	R/W	R/W	R/W	R	R	R	R
Bit	15	14	13	12	11	10	9	8	7	6	5	4	3	2	1	0
	—	—	—	—	—	—	—	—	—	TICMP4	TUDP4	TTCP4	—	—	—	TIP4
Initial Value	0	0	0	0	0	0	0	0	0	0	0	0	0	0	0	0
R/W	R	R	R	R	R	R	R	R	R	R/W	R/W	R/W	R	R	R	R/W

Bit	Bit Name	Initial Value	R/W	Description
31 to 28	—	All 0	R	Reserved Whenever it is read, 0 is read. The written value will be ignored.
27	TDHD	0b	R/W	Transmit Destination Option Header Enable When the frame from DMAC has a Destination Option header, this bit configures whether TOE ascribes this frame to Supported Frame or not. 0b: Ascribes to Unsupported Frame 1b: Ascribes to Supported Frame If bits 20, 21 and 22 of this register are '0', the configuration of this bit is ignored. Write to this bit when TPE is '0'.
26	TAHD	0b	R/W	Transmit Authentication Header Enable When the frame from DMAC has an AH header, this bit configures whether TOE ascribes this frame to Supported Frame or not. 0b: Ascribes to Unsupported Frame 1b: Ascribes to Supported Frame If bits 20, 21 and 22 of this register are '0', the configuration of this bit is ignored. Write to this bit when TPE is '0'.
25	TROUT	0b	R/W	Transmit Routing Header Enable When the frame from DMAC has a Routing header, this bit configures whether TOE ascribes this frame to Supported Frame or not. 0b: Ascribes to Unsupported Frame 1b: Ascribes to Supported Frame If bits 20, 21 and 22 of this register are '0', the configuration of this bit is ignored. Write to this bit when TPE is '0'.
24	THOP	0b	R/W	Transmit Hop-by-Hop Option Header Enable When the frame from DMAC has a Hop-by-Hop Option header, this bit configures whether TOE ascribes this frame to Supported Frame or not. 0b: Ascribes to Unsupported Frame 1b: Ascribes to Supported Frame If bits 20, 21 and 22 of this register are '0', the configuration of this bit is ignored. Write to this bit when TPE is '0'.
23	—	0b	R	Reserved Whenever it is read, 0 is read. The written value will be ignored.
22	TICMP6	0b	R/W	Transmit ICMP Checksum in IPv6 Enable Enable of IPv6 ICMP Checksum Calculation in the frame from DMAC. 0b: Disable 1b: Enable When this bit is '1', the value of bits [27:24] are valid. Write to this bit when TPE is '0'.

Bit	Bit Name	Initial Value	R/W	Description
21	TUDP6	0b	R/W	<p>Transmit UDP Checksum in IPv6 Enable</p> <p>Enable of IPv6 UDP Checksum Calculation in the frame from DMAC.</p> <p>0b: Disable 1b: Enable</p> <p>When this bit is '1', the value of bits [27:24] are valid. Write to this bit when TPE is '0'.</p>
20	TTCP6	0b	R/W	<p>Transmit TCP Checksum in IPv6 Enable</p> <p>Enable of IPv6 TCP Checksum Calculation in the frame from DMAC.</p> <p>0b: Disable 1b: Enable</p> <p>When this bit is '1', the value of bits [27:24] are valid. Write to this bit when TPE is '0'.</p>
19 to 7	—	All 0	R	<p>Reserved</p> <p>Whenever it is read, 0 is read. The written value will be ignored.</p>
6	TICMP4	0b	R/W	<p>Transmit ICMP Checksum in IPv4 Enable</p> <p>Enable of IPv4 ICMP Checksum Calculation in the frame from DMAC.</p> <p>0b: Disable 1b: Enable</p> <p>Write to this bit when TPE is '0'.</p>
5	TUDP4	0b	R/W	<p>Transmit UDP Checksum in IPv4 Enable</p> <p>Enable of IPv4 UDP Checksum Calculation in the frame from DMAC.</p> <p>0b: Disable 1b: Enable</p> <p>Write to this bit when TPE is '0'.</p>
4	TTCP4	0b	R/W	<p>Transmit TCP Checksum in IPv4 Enable</p> <p>Enable of IPv4 TCP Checksum Calculation in the frame from DMAC.</p> <p>0b: Disable 1b: Enable</p> <p>Write to this bit when TPE is '0'.</p>
3 to 1	—	All 0	R	<p>Reserved</p> <p>Whenever it is read, 0 is read. The written value will be ignored.</p>
0	TIP4	0b	R/W	<p>Transmit IPv4 Checksum Enable</p> <p>Enable of IPv4 Header Checksum Calculation in the frame from DMAC.</p> <p>0b: Disable 1b: Enable</p> <p>Write to this bit when TPE is '0'.</p>

30.4.3.3 Rx Frame Checksum Enable register (CSR2)

Bit	31	30	29	28	27	26	25	24	23	22	21	20	19	18	17	16
	—	—	—	—	RDHD	RAHD	RROUT	RHOP	—	RICMP6	RUDP6	RTCP6	—	—	—	—
Initial Value	0	0	0	0	0	0	0	0	0	0	0	0	0	0	0	0
R/W	R	R	R	R	R/W	R/W	R/W	R/W	R	R/W	R/W	R/W	R	R	R	R
Bit	15	14	13	12	11	10	9	8	7	6	5	4	3	2	1	0
	—	—	—	—	—	—	—	—	—	RICMP4	RUDP4	RTCP4	—	—	—	RIP4
Initial Value	0	0	0	0	0	0	0	0	0	0	0	0	0	0	0	0
R/W	R	R	R	R	R	R	R	R	R	R/W	R/W	R/W	R	R	R	R/W

Bit	Bit Name	Initial Value	R/W	Description
31 to 28	—	All 0	R	Reserved Whenever it is read, 0 is read. The written value will be ignored.
27	RDHD	0b	R/W	Receive Destination Option Header Enable When the frame from E-MAC has a Destination Option header, this bit configures whether TOE ascribes this frame to Supported Frame or not. 0b: Ascribes to Unsupported Frame 1b: Ascribes to Supported Frame If bits 20, 21 and 22 of this register are '0', the configuration of this bit is ignored. Write to this bit when RPE is '0'.
26	RAHD	0b	R/W	Receive Authentication Header Enable When the frame from E-MAC has an AH header, this bit configures whether TOE ascribes this frame to Supported Frame or not. 0b: Ascribes to Unsupported Frame 1b: Ascribes to Supported Frame If bits 20, 21 and 22 of this register are '0', the configuration of this bit is ignored. Write to this bit when RPE is '0'.
25	RROUT	0b	R/W	Receive Routing Header Enable When the frame from E-MAC has a Routing header, this bit configures whether TOE ascribes this frame to Supported Frame or not. 0b: Ascribes to Unsupported Frame 1b: Ascribes to Supported Frame If bits 20, 21 and 22 of this register are '0', the configuration of this bit is ignored. Write to this bit when RPE is '0'.
24	RHOP	0b	R/W	Receive Hop-by-Hop Option Header Enable When the frame from E-MAC has a Hop-by-Hop Option header, this bit configures whether TOE ascribes this frame to Supported Frame or not. 0b: Ascribes to Unsupported Frame 1b: Ascribes to Supported Frame If bits 20, 21 and 22 of this register are '0', the configuration of this bit is ignored. Write to this bit when RPE is '0'.
23	—	0b	R	Reserved Whenever it is read, 0 is read. The written value will be ignored.
22	RICMP6	0b	R/W	Receive ICMP Checksum in IPv6 Enable Enable of IPv6 ICMP Checksum Calculation in the frame from E-MAC. 0b: Disable 1b: Enable When this bit is '1', the value of bits [27:24] are valid. Write to this bit when RPE is '0'.

Bit	Bit Name	Initial Value	R/W	Description
21	RUDP6	0b	R/W	Receive UDP Checksum in IPv6 Enable Enable of IPv6 UDP Checksum Calculation in the frame from E-MAC. 0b: Disable 1b: Enable When this bit is '1', the value of bits [27:24] are valid. Write to this bit when RPE is '0'.
20	RTCP6	0b	R/W	Receive TCP Checksum in IPv6 Enable Enable of IPv6 TCP Checksum Calculation in the frame from E-MAC. 0b: Disable 1b: Enable When this bit is '1', the value of bits [27:24] are valid. Write to this bit when RPE is '0'.
19 to 7	—	All 0	R	Reserved Whenever it is read, 0 is read. The written value will be ignored.
6	RICMP4	0b	R/W	Receive ICMP Checksum in IPv4 Enable Enable of IPv4 ICMP Checksum Calculation in the frame from E-MAC. 0b: Disable 1b: Enable Write to this bit when RPE is '0'.
5	RUDP4	0b	R/W	Receive UDP Checksum in IPv4 Enable Enable of IPv4 UDP Checksum Calculation in the frame from E-MAC. 0b: Disable 1b: Enable Write to this bit when RPE is '0'.
4	RTCP4	0b	R/W	Receive TCP Checksum in IPv4 Enable Enable of IPv4 TCP Checksum Calculation in the frame from E-MAC. 0b: Disable 1b: Enable Write to this bit when RPE is '0'. These bits are read as 0. The write value should be always 0.
3 to 1	—	All 0	R	Reserved Whenever it is read, 0 is read. The written value will be ignored.
0	RIP4	0b	R/W	Receive IPv4 Checksum Enable Enable of IPv4 Header Checksum Calculation in the frame from E-MAC. 0b: Disable 1b: Enable Write to this bit when RPE is '0'.

30.4.3.4 Tx Extended Header Number register (CSR3)

Bit	31	30	29	28	27	26	25	24	23	22	21	20	19	18	17	16
	—	—	—	—	—	—	—	—	—	—	—	—	—	—	—	—
Initial Value	0	0	0	0	0	0	0	0	0	0	0	0	0	0	0	0
R/W	R	R	R	R	R	R	R	R	R	R	R	R	R	R	R	R
Bit	15	14	13	12	11	10	9	8	7	6	5	4	3	2	1	0
	—	—	—	—	—	—	—	—	—	—	—	—	TNUEXHED[3:0]			
Initial Value	0	0	0	0	0	0	0	0	0	0	0	0	1	0	0	0
R/W	R	R	R	R	R	R	R	R	R	R	R	R	R/W	R/W	R/W	R/W

Bit	Bit Name	Initial Value	R/W	Description
31 to 4	—	All 0	R	Reserved Whenever it is read, 0 is read. The written value will be ignored.
3 to 0	TNUEXHED	H'8	R/W	Transmit Support Number of Extension Header Transmit Support Number of Extension Header in the frame from DMAC H'0: 16 H'1: 1 ... H'E: 14 H'F: 15 If the number of Extension Header in the IPv6 frame is over the configuration of this field, TOE ascribes this frame to unsupported. Write to this field when TPE is '0'.

30.4.3.5 Rx Extended Header Number register (CSR4)

Bit	31	30	29	28	27	26	25	24	23	22	21	20	19	18	17	16
	—	—	—	—	—	—	—	—	—	—	—	—	—	—	—	—
Initial Value	0	0	0	0	0	0	0	0	0	0	0	0	0	0	0	0
R/W	R	R	R	R	R	R	R	R	R	R	R	R	R	R	R	R
Bit	15	14	13	12	11	10	9	8	7	6	5	4	3	2	1	0
	—	—	—	—	—	—	—	—	—	—	—	—	RNUEXHED[3:0]			
Initial Value	0	0	0	0	0	0	0	0	0	0	0	0	1	0	0	0
R/W	R	R	R	R	R	R	R	R	R	R	R	R	R/W	R/W	R/W	R/W

Bit	Bit Name	Initial Value	R/W	Description
31 to 4	—	All 0	R	Reserved Whenever it is read, 0 is read. The written value will be ignored.
3 to 0	RNUEXHED	H'8	R/W	Receive Support Number of Extension Header Receive Support Number of Extension Header in the frame from E-MAC. H'0: 16 H'1: 1 ... H'E: 14 H'F: 15 If the number of Extension Header in the IPv6 frame is over the configuration of this field, TOE ascribes this frame to unsupported. Write to this field when RPE is '0'.

30.4.3.6 Unsupported Tx Frame Counter register (CSR20)

Bit	31	30	29	28	27	26	25	24	23	22	21	20	19	18	17	16
	—	—	—	—	—	—	—	—	—	—	—	—	—	—	—	—
Initial Value	0	0	0	0	0	0	0	0	0	0	0	0	0	0	0	0
R/W	R	R	R	R	R	R	R	R	R	R	R	R	R	R	R	R
Bit	15	14	13	12	11	10	9	8	7	6	5	4	3	2	1	0
	TNSCNT[15:0]															
Initial Value	0	0	0	0	0	0	0	0	0	0	0	0	0	0	0	0
R/W	R/W	R/W	R/W	R/W	R/W	R/W	R/W	R/W	R/W	R/W	R/W	R/W	R/W	R/W	R/W	R/W

Bit	Bit Name	Initial Value	R/W	Description
31 to 16	—	All 0	R	Reserved Whenever it is read, 0 is read. The written value will be ignored.
15 to 0	TNSCNT	H'0000	R/W	Transmit Not Support Frame Counter Counter for Transmitted Unsupported Frames When CSR0_bit0 is '1', this register is cleared to '0' by read access. When CSR0_bit0 is '0', this register is cleared to '0' by write access of any data. The condition of counting up is OR of followings. <ul style="list-style-type: none"> • TYPE/TPID is Unsupported • Not ("MF = 0" and "Fragment Offset = H'0000") • Protocol is Unsupported • Next Header of IPv6 frame is Unsupported • The number of Next Header in IPv6 frame is 9 or more • Checksum calculation for a particular frame is disabled by CSR1 • The Frame Length is shorter than the result of Frame Analysis by TOE.

30.4.3.7 Unsupported Rx Frame Counter register (CSR30)

Bit	31	30	29	28	27	26	25	24	23	22	21	20	19	18	17	16
	—	—	—	—	—	—	—	—	—	—	—	—	—	—	—	—
Initial Value	0	0	0	0	0	0	0	0	0	0	0	0	0	0	0	0
R/W	R	R	R	R	R	R	R	R	R	R	R	R	R	R	R	R
Bit	15	14	13	12	11	10	9	8	7	6	5	4	3	2	1	0
	RNSCNT[15:8]															
Initial Value	0	0	0	0	0	0	0	0	0	0	0	0	0	0	0	0
R/W	R/W	R/W	R/W	R/W	R/W	R/W	R/W	R/W	R/W	R/W	R/W	R/W	R/W	R/W	R/W	R/W

Bit	Bit Name	Initial Value	R/W	Description
31 to 16	—	All 0	R	Reserved Whenever it is read, 0 is read. The written value will be ignored.
15 to 0	RNSCNT	H'0000	R/W	Receive Not Support Frame Counter Counter for Received Unsupported Frames When CSR0_bit0 is '1', this register is cleared to '0' by read access. When CSR0_bit0 is '0', this register is cleared to '0' by write access of any data. The condition of counting up is OR of followings. <ul style="list-style-type: none"> • TYPE/TPID is Unsupported • Not ("MF = 0" and "Fragment Offset = H'0000") • Protocol is Unsupported • Next Header of IPv6 frame is Unsupported • The number of Next Header in IPv6 frame is 9 or more • Checksum calculation for a particular frame is disabled by CSR2 • The Frame Length is shorter than the result of Frame Analysis by TOE.

30.4.3.8 Rx IPv4 Header checksum Error Counter register (CSR31)

Bit	31	30	29	28	27	26	25	24	23	22	21	20	19	18	17	16
	—	—	—	—	—	—	—	—	—	—	—	—	—	—	—	—
Initial Value	0	0	0	0	0	0	0	0	0	0	0	0	0	0	0	0
R/W	R	R	R	R	R	R	R	R	R	R	R	R	R	R	R	R
Bit	15	14	13	12	11	10	9	8	7	6	5	4	3	2	1	0
	R4ECNT[15:0]															
Initial Value	0	0	0	0	0	0	0	0	0	0	0	0	0	0	0	0
R/W	R/W	R/W	R/W	R/W	R/W	R/W	R/W	R/W	R/W	R/W	R/W	R/W	R/W	R/W	R/W	R/W

Bit	Bit Name	Initial Value	R/W	Description
31 to 16	—	All 0	R	Reserved Whenever it is read, 0 is read. The written value will be ignored.
15 to 0	R4ECNT	H'0000	R/W	Receive IPv4 Header Checksum Error Counter Counter for the number of IPv4 Header Checksum Error in the frames from E-MAC. When CSR0_bit0 is '1', this register is cleared to '0' by read access. When CSR0_bit0 is '0', this register is cleared to '0' by write access of any data. The condition of counting up is following. When the frame which has IPv4 Checksum Error comes, TOE counts up this register.

30.4.3.9 Rx TCP/UDP/ICMP checksum Error Counter register (CSR32)

Bit	31	30	29	28	27	26	25	24	23	22	21	20	19	18	17	16
	—	—	—	—	—	—	—	—	—	—	—	—	—	—	—	—
Initial Value	0	0	0	0	0	0	0	0	0	0	0	0	0	0	0	0
R/W	R	R	R	R	R	R	R	R	R	R	R	R	R	R	R	R
Bit	15	14	13	12	11	10	9	8	7	6	5	4	3	2	1	0
	RTUECNT[15:0]															
Initial Value	0	0	0	0	0	0	0	0	0	0	0	0	0	0	0	0
R/W	R/W	R/W	R/W	R/W	R/W	R/W	R/W	R/W	R/W	R/W	R/W	R/W	R/W	R/W	R/W	R/W

Bit	Bit Name	Initial Value	R/W	Description
31 to 16	—	All 0	R	Reserved Whenever it is read, 0 is read. The written value will be ignored.
15 to 0	RTUECNT	H'0000	R/W	Receive TCP/UDP/ICMP Checksum Error Counter Counter for the number of TCP/UDP/ICMP Checksum Error in the frames from E-MAC. When CSR0_bit0 is '1', this register is cleared to '0' by read access. When CSR0_bit0 is '0', this register is cleared to '0' by write access of any data. The condition of counting up is following. When the frame which has TCP/UDP/ICMP Checksum Error comes, TOE counts up this register.

30.4.3.10 Filter Operation/Auto Response Enable register (CSFR00)

Bit	31	30	29	28	27	26	25	24	23	22	21	20	19	18	17	16
	—	—	—	arp_ns_abt_en	—	—	reply_fifo_en	reg_fifo_en	true_false	ieee_len_fen	ana_stp_fen	v6_ana_protocol_fen	ns_dis_fen	ns_dup_fen	ns_uni_nopt_fen	ns_uni_fen
Initial Value	0	0	0	1	0	0	0	0	0	1	0	0	0	0	0	0
R/W	R	R	R	R/W	R	R	R/W	R/W	R/W	R/W	R/W	R/W	R/W	R/W	R/W	R/W
Bit	15	14	13	12	11	10	9	8	7	6	5	4	3	2	1	0
	ns_mul_fen	arp_nor_eq_fen	garp_sel_f_fen	garp_ot_her_fen	arp_self_fen	arp_oth_er_fen	mac_da_mul_fen	mac_da_bro_fen	mac_da_uni_fen	v6_udp_pt_fen	v4_udp_pt_fen	v6_protocol_fen	v4_protocol_fen	type_fen	sby_mode[1:0]	
Initial Value	0	0	0	0	0	0	0	0	0	0	0	0	0	0	0	0
R/W	R/W	R/W	R/W	R/W	R/W	R/W	R/W	R/W	R/W	R/W	R/W	R/W	R/W	R/W	R/W	R/W

Bit	Bit Name	Initial Value	R/W	Description
31 to 29	—	All 0	R	Reserved Whenever it is read, 0 is read. The written value will be ignored.
28	arp_ns_abt_en	1b	R/W	ARP ns frame Abort Enable Configuration of Transferred to DMAC or Discarded for the frame which was stored to REPLY FIFO of REG FIFO. 0b: Transferred to DMAC 1b: Discarded (Aborted)
27 to 26	—	All 0	R	Reserved Whenever it is read, 0 is read. The written value will be ignored.
25	reply_fifo_en	0b	R/W	Reply FIFO Enable Enable of Auto Response Function for ARP REQ and Neighbor Solicitations 0b: Disable 1b: Enable
24	reg_fifo_en	0b	R/W	Reg FIFO Enable Enable of Interrupt which occurs by reception of ARP REQ and Neighbor Solicitations. 0b: Disable 1b: Enable
23	true_false	0b	R/W	True False mode Discarding condition of the frame by filter. 0b: Discard by unmatched to filter condition 1b: Discard by match to filter condition
22	ieee_len_fen	1b	R/W	IEEE Length Filter Enable Filtering Operation for the IEEE802.3 Length Frame. 0b: Non-Filtering 1b: Filtering
21	ana_stp_fen	0b	R/W	Analysis stop Filter Enable Filtering Operation for the case of stopping frame analysis due to impossible analysis. 0b: Non-Filtering 1b: Filtering
20	v6_ana_protocol_fen	0b	R/W	IPv6 Analysis protocol Filter Enable Filtering Operation for the case of stopping frame analysis because Protocol No is not match to configured value by v6_ana_protocol_0-15. 0b: Non-Filtering 1b: Filtering
19	ns_dis_fen	0b	R/W	Neighbor Solicitation discarded Filter Enable Filtering Operation for the invalid Neighbor Solicitations. 0b: Non-Filtering 1b: Filtering

Bit	Bit Name	Initial Value	R/W	Description
18	ns_dup_fen	0b	R/W	Neighbor Solicitation Duplicate Filter Enable Filtering Operation for the IP Duplicate Detection Neighbor Solicitations of Local Station. 0b: Non-Filtering 1b: Filtering
17	ns_uni_nopt_fen	0b	R/W	Neighbor Solicitation Unicast no option Filter Enable Filtering Operation for the Unicast Neighbor Solicitations of Local Station. (Except "Option Type=1" or No "Option Type") 0b: Non-Filtering 1b: Filtering
16	ns_uni_fen	0b	R/W	Neighbor Solicitation Unicast Filter Enable Filtering Operation for the Unicast Neighbor Solicitations of Local Station. (Option Type=1) 0b: Non-Filtering 1b: Filtering
15	ns_mul_fen	0b	R/W	Neighbor Solicitation Multicast Filter Enable Filtering Operation for the Multicast Neighbor Solicitations of Local Station. 0b: Non-Filtering 1b: Filtering
14	arp_noreq_fen	0b	R/W	ARP No request Filter Enable Filtering Operation for the ARP frame except ARP request. 0b: Non-Filtering 1b: Filtering
13	garp_self_fen	0b	R/W	GARP Self Filter Enable Filtering Operation for the GARP request of Local Station. 0b: Non-Filtering 1b: Filtering
12	garp_other_fen	0b	R/W	GARP Other Filter Enable Filtering Operation for the GARP request of Other Station. 0b: Non-Filtering 1b: Filtering
11	arp_self_fen	0b	R/W	ARP Self Filter Enable Filtering Operation for the ARP request of Local Station. 0b: Non-Filtering 1b: Filtering
10	arp_other_fen	0b	R/W	ARP Other Filter Enable Filtering Operation for the ARP request of Other Station. 0b: Non-Filtering 1b: Filtering
9	mac_da_mul_fen	0b	R/W	MAC DA Multicast Filter Enable Filtering Operation by MAC DA. (multicast) 0b: Non-Filtering 1b: Filtering
8	mac_da_bro_fen	0b	R/W	MAC DA Broadcast Filter Enable Filtering Operation by MAC DA. (broadcast) 0b: Non-Filtering 1b: Filtering
7	mac_da_uni_fen	0b	R/W	MAC DA Unicast Filter Enable Filtering Operation by MAC DA. (unicast) 0b: Non-Filtering 1b: Filtering

Bit	Bit Name	Initial Value	R/W	Description
6	v6_udp_pt_fen	0b	R/W	IPv6 UDP Port Filter Enable Filtering Operation by IPv6 UDP port number. (destination) 0b: Non-Filtering 1b: Filtering
5	v4_udp_pt_fen	0b	R/W	IPv4 UDP Port Filter Enable Filtering Operation by IPv4 UDP port number. (destination) 0b: Non-Filtering 1b: Filtering
4	v6_protocol_fen	0b	R/W	IPv6 protocol Filter Enable Filtering Operation by IPv6 Protocol number. 0b: Non-Filtering 1b: Filtering
3	v4_protocol_fen	0b	R/W	IPv4 protocol Filter Enable Filtering Operation by IPv4 Protocol number. 0b: Non-Filtering 1b: Filtering
2	type_fen	0b	R/W	Type Filter Enable Filtering Operation by Ethernet TYPE/TPID. 0b: Non-Filtering 1b: Filtering
1 to 0	sby_mode	00b	R/W	Standby Mode Filtering Operation Mode 00b: Non-Filtering 1*b: Filtering

30.4.3.11 Local IPv4 address register (CSFR01)

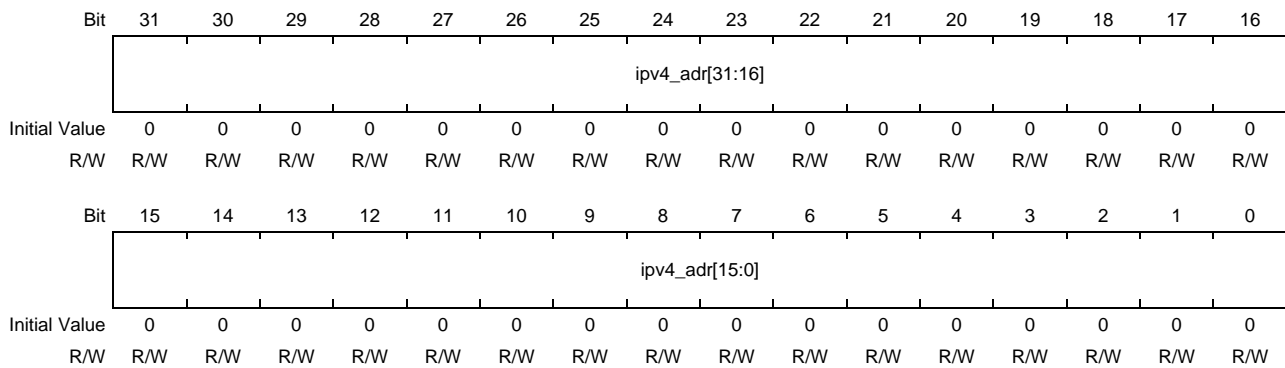

Bit	Bit Name	Initial Value	R/W	Description
31 to 0	ipv4_adr	H'0000_0000	R/W	IPv4 address IPv4 Address of Local Station Write to this field when CSFR00.reply_fifo_en = "0", reg_fifo_en = "0" and sby_mode = "00b".

30.4.3.12 Local IPv6 address register i (i = 0 to 3) (CSFR02_i)

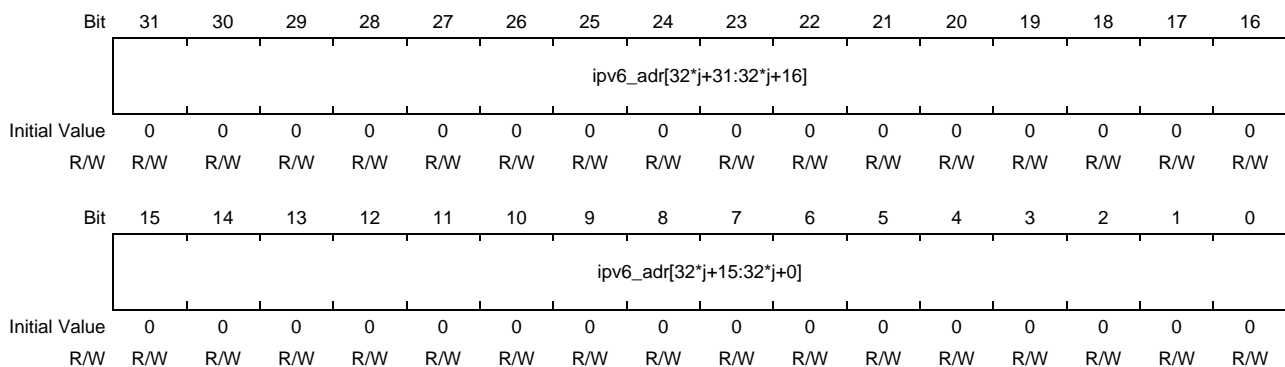

Bit	Bit Name	Initial Value	R/W	Description
31 to 0	ipv6_adr	H'0000_0000	R/W	IPv6 Address IPv6 Address[32*j+31:32*j] of Local Station The relationship between 'i' and 'j' is the following. i = 0 -> j = 3 i = 1 -> j = 2 i = 2 -> j = 1 i = 3 -> j = 0 Write to this field when CSFR00.reply_fifo_en = "0", reg_fifo_en = "0" and sby_mode = "00b".

30.4.3.13 Upper Local MAC address register (CSFR03_U)

Bit	31	30	29	28	27	26	25	24	23	22	21	20	19	18	17	16
	—	—	—	—	—	—	—	—	—	—	—	—	—	—	—	—
Initial Value	0	0	0	0	0	0	0	0	0	0	0	0	0	0	0	0
R/W	R	R	R	R	R	R	R	R	R	R	R	R	R	R	R	R
Bit	15	14	13	12	11	10	9	8	7	6	5	4	3	2	1	0
	mac_adr[47:32]															
Initial Value	0	0	0	0	0	0	0	0	0	0	0	0	0	0	0	0
R/W	R/W	R/W	R/W	R/W	R/W	R/W	R/W	R/W	R/W	R/W	R/W	R/W	R/W	R/W	R/W	R/W

Bit	Bit Name	Initial Value	R/W	Description
31 to 16	—	All 0	R	Reserved Whenever it is read, 0 is read. The written value will be ignored.
15 to 0	mac_adr	H'0000	R/W	MAC Address MAC Address [47:32] of Local Station Write to this field when CSFR00.reply_fifo_en = "0", reg_fifo_en = "0" and sby_mode = "00b".

30.4.3.14 Lower Local MAC address register (CSFR03_L)

Bit	31	30	29	28	27	26	25	24	23	22	21	20	19	18	17	16
	mac_adr[31:16]															
Initial Value	0	0	0	0	0	0	0	0	0	0	0	0	0	0	0	0
R/W	R/W	R/W	R/W	R/W	R/W	R/W	R/W	R/W	R/W	R/W	R/W	R/W	R/W	R/W	R/W	R/W
Bit	15	14	13	12	11	10	9	8	7	6	5	4	3	2	1	0
	mac_adr[15:0]															
Initial Value	0	0	0	0	0	0	0	0	0	0	0	0	0	0	0	0
R/W	R/W	R/W	R/W	R/W	R/W	R/W	R/W	R/W	R/W	R/W	R/W	R/W	R/W	R/W	R/W	R/W

Bit	Bit Name	Initial Value	R/W	Description
31 to 0	mac_adr	H'0000_0000	R/W	MAC Address MAC Address [32:0] of Local Station Write to this field when CSFR00.reply_fifo_en = "0", reg_fifo_en = "0" and sby_mode = "00b".

30.4.3.15 IPv6 no_next_header Protocol Number register (CSFR04)

Bit	31	30	29	28	27	26	25	24	23	22	21	20	19	18	17	16
	—	—	—	—	—	—	—	—	—	—	—	—	—	—	—	—
Initial Value	0	0	0	0	0	0	0	0	0	0	0	0	0	0	0	0
R/W	R	R	R	R	R	R	R	R	R	R	R	R	R	R	R	R
Bit	15	14	13	12	11	10	9	8	7	6	5	4	3	2	1	0
	—	—	—	—	—	—	—	—	no_next_header[7:0]							
Initial Value	0	0	0	0	0	0	0	0	0	0	1	1	1	0	1	1
R/W	R	R	R	R	R	R	R	R	R/W	R/W	R/W	R/W	R/W	R/W	R/W	R/W

Bit	Bit Name	Initial Value	R/W	Description
31 to 8	—	All 0	R	Reserved Whenever it is read, 0 is read. The written value will be ignored.
7 to 0	no_next_header	H'3B	R/W	Protocol Number of IPv6 no_next_header Usually, do not need to change from Initial values (59). Write to this field when CSFR00.sby mode is '00b'.

30.4.3.16 Ethernet Type Condition register i (i = 0 to 3) (CSFR10_i)

Bit	31	30	29	28	27	26	25	24	23	22	21	20	19	18	17	16
	type_2*i+1[15:8]															
Initial Value	0	0	0	0	0	0	0	0	0	0	0	0	0	0	0	0
R/W	R/W	R/W	R/W	R/W	R/W	R/W	R/W	R/W	R/W	R/W	R/W	R/W	R/W	R/W	R/W	R/W
Bit	15	14	13	12	11	10	9	8	7	6	5	4	3	2	1	0
	type_2*i[15:0]															
Initial Value	0	0	0	0	0	0	0	0	0	0	0	0	0	0	0	0
R/W	R/W	R/W	R/W	R/W	R/W	R/W	R/W	R/W	R/W	R/W	R/W	R/W	R/W	R/W	R/W	R/W

Bit	Bit Name	Initial Value	R/W	Description
31 to 16	type_2*i+1	H'0000	R/W	Ethernet Type 2*i+1 Configuration of the Ethernet TYPE for Filter Condition and Interrupt Condition. Write to this field when CSFR10.type_2*i+1_en is "0".
15 to 0	type_2*i	H'0000	R/W	Ethernet Type 2*i Configuration of the Ethernet TYPE for Filter Condition and Interrupt Condition. Write to this field when CSFR10.type_2*i_en is "0".

30.4.3.17 Ethernet Type Condition Enable register (CSFR10)

Bit	31	30	29	28	27	26	25	24	23	22	21	20	19	18	17	16
	—	—	—	—	—	—	—	—	—	—	—	—	—	—	—	—
Initial Value	0	0	0	0	0	0	0	0	0	0	0	0	0	0	0	0
R/W	R	R	R	R	R	R	R	R	R	R	R	R	R	R	R	R
Bit	15	14	13	12	11	10	9	8	7	6	5	4	3	2	1	0
	—	—	—	—	—	—	—	—	type_7_en	type_6_en	type_5_en	type_4_en	type_3_en	type_2_en	type_1_en	type_0_en
Initial Value	0	0	0	0	0	0	0	0	0	0	0	0	0	0	0	0
R/W	R	R	R	R	R	R	R	R	R/W	R/W	R/W	R/W	R/W	R/W	R/W	R/W

Bit	Bit Name	Initial Value	R/W	Description
31 to 8	—	All 0	R	Reserved Whenever it is read, 0 is read. The written value will be ignored.
7	type_7_en	0b	R/W	type_7 enable Enable for the value of type_7 which is configured in CSFR10_i. 0b: Disable 1b: Enable
6	type_6_en	0b	R/W	type_6 enable Enable for the value of type_6 which is configured in CSFR10_i. 0b: Disable 1b: Enable
5	type_5_en	0b	R/W	type_5 enable Enable for the value of type_5 which is configured in CSFR10_i. 0b: Disable 1b: Enable
4	type_4_en	0b	R/W	type_4 enable Enable for the value of type_4 which is configured in CSFR10_i. 0b: Disable 1b: Enable
3	type_3_en	0b	R/W	type_3 enable Enable for the value of type_3 which is configured in CSFR10_i. 0b: Disable 1b: Enable
2	type_2_en	0b	R/W	type_2 enable Enable for the value of type_2 which is configured in CSFR10_i. 0b: Disable 1b: Enable
1	type_1_en	0b	R/W	type_1 enable Enable for the value of type_1 which is configured in CSFR10_i. 0b: Disable 1b: Enable
0	type_0_en	0b	R/W	type_0 enable Enable for the value of type_0 which is configured in CSFR10_i. 0b: Disable 1b: Enable

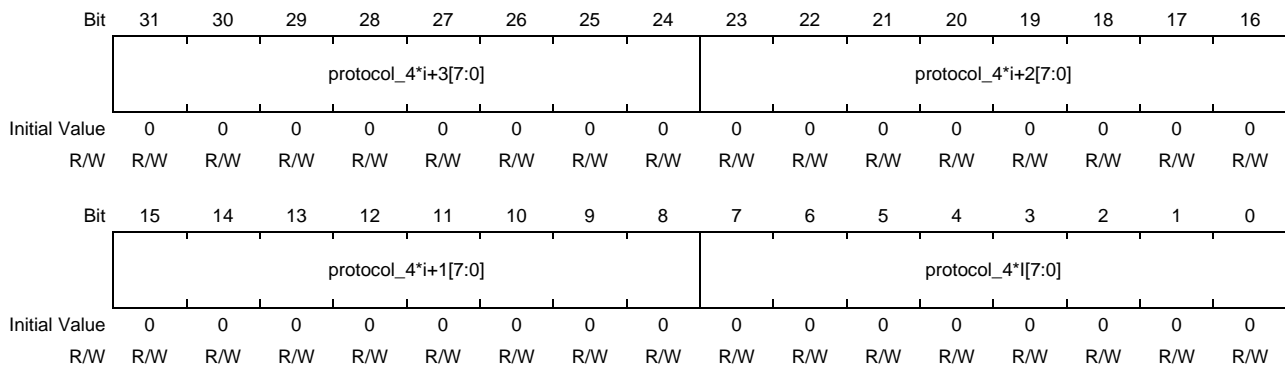
30.4.3.18 Protocol Condition register i (i = 0 to 3) (CSFR11_i)

Bit	Bit Name	Initial Value	R/W	Description
31 to 24	protocol_4*i+3	H'00	R/W	protocol No 4*i+3 Configuration of the Protocol No for Filter Condition and Interrupt Condition. Write to this field when CSFR11. protocol_4*i+3_en is "0".
23 to 16	protocol_4*i+2	H'00	R/W	protocol No 4*i+2 Configuration of the Protocol No for Filter Condition and Interrupt Condition. Write to this field when CSFR11. protocol_4*i+2_en is "0".
15 to 8	protocol_4*i+1	H'00	R/W	protocol No 4*i+1 Configuration of the Protocol No for Filter Condition and Interrupt Condition. Write to this field when CSFR11. protocol_4*i+1_en is "0".
7 to 0	protocol_4*i	H'00	R/W	protocol No 4*i Write to this field when CSFR11. protocol_4*i_en is "0".

30.4.3.19 Protocol Condition Enable register (CSFR11)

Bit	31	30	29	28	27	26	25	24	23	22	21	20	19	18	17	16
	—	—	—	—	—	—	—	—	—	—	—	—	—	—	—	—
Initial Value	0	0	0	0	0	0	0	0	0	0	0	0	0	0	0	0
R/W	R	R	R	R	R	R	R	R	R	R	R	R	R	R	R	R
Bit	15	14	13	12	11	10	9	8	7	6	5	4	3	2	1	0
	protocol_15_en	protocol_14_en	protocol_13_en	protocol_12_en	protocol_11_en	protocol_10_en	protocol_9_en	protocol_8_en	protocol_7_en	protocol_6_en	protocol_5_en	protocol_4_en	protocol_3_en	protocol_2_en	protocol_1_en	protocol_0_en
Initial Value	0	0	0	0	0	0	0	0	0	0	0	0	0	0	0	0
R/W	R/W	R/W	R/W	R/W	R/W	R/W	R/W	R/W	R/W	R/W	R/W	R/W	R/W	R/W	R/W	R/W

Bit	Bit Name	Initial Value	R/W	Description
31 to 16	—	All 0	R	Reserved Whenever it is read, 0 is read. The written value will be ignored.
15	protocol_15_en	0b	R/W	protocol_15 enable Enable for the value of protocol_15 which is configured in CSFR11_i. 0b: Disable 1b: Enable
14	protocol_14_en	0b	R/W	protocol_14 enable Enable for the value of protocol_14 which is configured in CSFR11_i. 0b: Disable 1b: Enable
13	protocol_13_en	0b	R/W	protocol_13 enable Enable for the value of protocol_13 which is configured in CSFR11_i. 0b: Disable 1b: Enable
12	protocol_12_en	0b	R/W	protocol_12 enable Enable for the value of protocol_12 which is configured in CSFR11_i. 0b: Disable 1b: Enable
11	protocol_11_en	0b	R/W	protocol_11 enable Enable for the value of protocol_11 which is configured in CSFR11_i. 0b: Disable 1b: Enable
10	protocol_10_en	0b	R/W	protocol_10 enable Enable for the value of protocol_10 which is configured in CSFR11_i. 0b: Disable 1b: Enable
9	protocol_9_en	0b	R/W	protocol_9 enable Enable for the value of protocol_9 which is configured in CSFR11_i. 0b: Disable 1b: Enable
8	protocol_8_en	0b	R/W	protocol_8 enable Enable for the value of protocol_8 which is configured in CSFR11_i. 0b: Disable 1b: Enable
7	protocol_7_en	0b	R/W	protocol_7 enable Enable for the value of protocol_7 which is configured in CSFR11_i. 0b: Disable 1b: Enable

Bit	Bit Name	Initial Value	R/W	Description
6	protocol_6_en	0b	R/W	protocol_6 enable Enable for the value of protocol_6 which is configured in CSFR11_i. 0b: Disable 1b: Enable
5	protocol_5_en	0b	R/W	protocol_5 enable Enable for the value of protocol_5 which is configured in CSFR11_i. 0b: Disable 1b: Enable
4	protocol_4_en	0b	R/W	protocol_4 enable Enable for the value of protocol_4 which is configured in CSFR11_i. 0b: Disable 1b: Enable
3	protocol_3_en	0b	R/W	protocol_3 enable Enable for the value of protocol_3 which is configured in CSFR11_i. 0b: Disable 1b: Enable
2	protocol_2_en	0b	R/W	protocol_2 enable Enable for the value of protocol_2 which is configured in CSFR11_i. 0b: Disable 1b: Enable
1	protocol_1_en	0b	R/W	protocol_1 enable Enable for the value of protocol_1 which is configured in CSFR11_i. 0b: Disable 1b: Enable
0	protocol_0_en	0b	R/W	protocol_0 enable Enable for the value of protocol_0 which is configured in CSFR11_i. 0b: Disable 1b: Enable

30.4.3.20 UDP Port Condition register i (i = 0 to 11) (CSFR12_i)

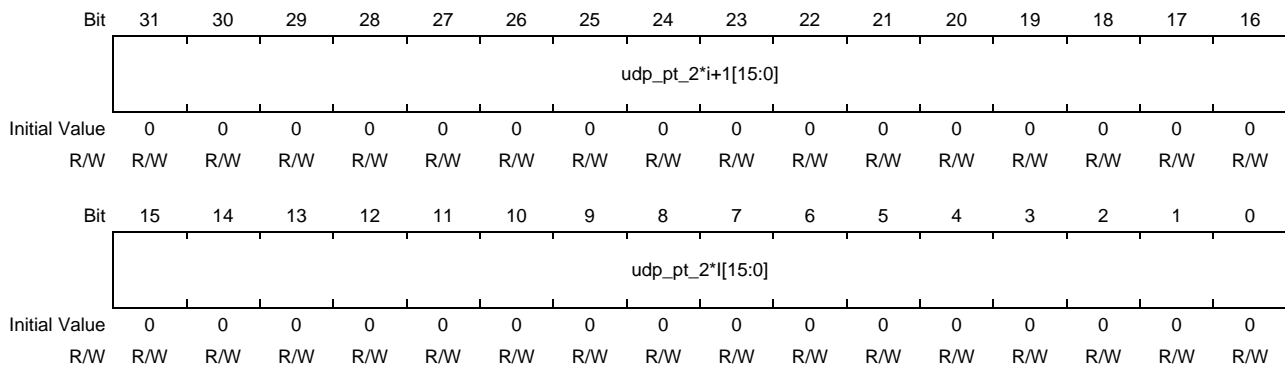

Bit	Bit Name	Initial Value	R/W	Description
31 to 16	udp_pt_2*i+1	H'0000	R/W	UDP port No. Configuration of the UDP Port No for Filter Condition and Interrupt Condition. Write to this field when CSFR12. udp_pt_2*i+1_en is "0".
15 to 0	udp_pt_2*i	H'0000	R/W	UDP port No. Configuration of the UDP Port No for Filter Condition and Interrupt Condition. Write to this field when CSFR12. udp_pt_2*i_en is "0".

30.4.3.21 UDP Port Condition Enable register (CSFR12)

Bit	31	30	29	28	27	26	25	24	23	22	21	20	19	18	17	16
	—	—	—	—	—	—	—	—	udp_pt_23_en	udp_pt_22_en	udp_pt_21_en	udp_pt_20_en	udp_pt_19_en	udp_pt_18_en	udp_pt_17_en	udp_pt_16_en
Initial Value	0	0	0	0	0	0	0	0	0	0	0	0	0	0	0	0
R/W	R	R	R	R	R	R	R	R	R/W	R/W	R/W	R/W	R/W	R/W	R/W	R/W

Bit	15	14	13	12	11	10	9	8	7	6	5	4	3	2	1	0
	udp_pt_15_en	udp_pt_14_en	udp_pt_13_en	udp_pt_12_en	udp_pt_11_en	udp_pt_10_en	udp_pt_9_en	udp_pt_8_en	udp_pt_7_en	udp_pt_6_en	udp_pt_5_en	udp_pt_4_en	udp_pt_3_en	udp_pt_2_en	udp_pt_1_en	udp_pt_0_en
Initial Value	0	0	0	0	0	0	0	0	0	0	0	0	0	0	0	0
R/W	R/W	R/W	R/W	R/W	R/W	R/W	R/W	R/W	R/W	R/W	R/W	R/W	R/W	R/W	R/W	R/W

Bit	Bit Name	Initial Value	R/W	Description
31 to 24	—	All 0	R	Reserved Whenever it is read, 0 is read. The written value will be ignored.
23	udp_pt_23_en	0b	R/W	udp_pt_23 enable Enable for the value of udp_pt_23 which is configured in CSFR12_i. 0b: Disable 1b: Enable
22	udp_pt_22_en	0b	R/W	udp_pt_22 enable Enable for the value of udp_pt_22 which is configured in CSFR12_i. 0b: Disable 1b: Enable
21	udp_pt_21_en	0b	R/W	udp_pt_21 enable Enable for the value of udp_pt_21 which is configured in CSFR12_i. 0b: Disable 1b: Enable
20	udp_pt_20_en	0b	R/W	udp_pt_20 enable Enable for the value of udp_pt_20 which is configured in CSFR12_i. 0b: Disable 1b: Enable
19	udp_pt_19_en	0b	R/W	udp_pt_19 enable Enable for the value of udp_pt_19 which is configured in CSFR12_i. 0b: Disable 1b: Enable
18	udp_pt_18_en	0b	R/W	udp_pt_18 enable Enable for the value of udp_pt_18 which is configured in CSFR12_i. 0b: Disable 1b: Enable
17	udp_pt_17_en	0b	R/W	udp_pt_17 enable Enable for the value of udp_pt_17 which is configured in CSFR12_i. 0b: Disable 1b: Enable
16	udp_pt_16_en	0b	R/W	udp_pt_16 enable Enable for the value of udp_pt_16 which is configured in CSFR12_i. 0b: Disable 1b: Enable
15	udp_pt_15_en	0b	R/W	udp_pt_15 enable Enable for the value of udp_pt_15 which is configured in CSFR12_i. 0b: Disable 1b: Enable

Bit	Bit Name	Initial Value	R/W	Description
14	udp_pt_14_en	0b	R/W	udp_pt_14 enable Enable for the value of udp_pt_14 which is configured in CSFR12_i. 0b: Disable 1b: Enable
13	udp_pt_13_en	0b	R/W	udp_pt_13 enable Enable for the value of udp_pt_13 which is configured in CSFR12_i. 0b: Disable 1b: Enable
12	udp_pt_12_en	0b	R/W	udp_pt_12 enable Enable for the value of udp_pt_12 which is configured in CSFR12_i. 0b: Disable 1b: Enable
11	udp_pt_11_en	0b	R/W	udp_pt_11 enable Enable for the value of udp_pt_11 which is configured in CSFR12_i. 0b: Disable 1b: Enable
10	udp_pt_10_en	0b	R/W	udp_pt_10 enable Enable for the value of udp_pt_10 which is configured in CSFR12_i. 0b: Disable 1b: Enable
9	udp_pt_9_en	0b	R/W	udp_pt_9 enable Enable for the value of udp_pt_9 which is configured in CSFR12_i. 0b: Disable 1b: Enable
8	udp_pt_8_en	0b	R/W	udp_pt_8 enable Enable for the value of udp_pt_8 which is configured in CSFR12_i. 0b: Disable 1b: Enable
7	udp_pt_7_en	0b	R/W	udp_pt_7 enable Enable for the value of udp_pt_7 which is configured in CSFR12_i. 0b: Disable 1b: Enable
6	udp_pt_6_en	0b	R/W	udp_pt_6 enable Enable for the value of udp_pt_6 which is configured in CSFR12_i. 0b: Disable 1b: Enable
5	udp_pt_5_en	0b	R/W	udp_pt_5 enable Enable for the value of udp_pt_5 which is configured in CSFR12_i. 0b: Disable 1b: Enable
4	udp_pt_4_en	0b	R/W	udp_pt_4 enable Enable for the value of udp_pt_4 which is configured in CSFR12_i. 0b: Disable 1b: Enable
3	udp_pt_3_en	0b	R/W	udp_pt_3 enable Enable for the value of udp_pt_3 which is configured in CSFR12_i. 0b: Disable 1b: Enable
2	udp_pt_2_en	0b	R/W	udp_pt_2 enable Enable for the value of udp_pt_2 which is configured in CSFR12_i. 0b: Disable 1b: Enable

Bit	Bit Name	Initial Value	R/W	Description
1	udp_pt_1_en	0b	R/W	udp_pt_1 enable Enable for the value of udp_pt_1 which is configured in CSFR12_i. 0b: Disable 1b: Enable
0	udp_pt_0_en	0b	R/W	udp_pt_0 enable Enable for the value of udp_pt_0 which is configured in CSFR12_i. 0b: Disable 1b: Enable

30.4.3.22 Upper MAC DA unicast address Condition register (CSFR13_U)

Bit	31	30	29	28	27	26	25	24	23	22	21	20	19	18	17	16
	[Reserved]															
Initial Value	0	0	0	0	0	0	0	0	0	0	0	0	0	0	0	0
R/W	R	R	R	R	R	R	R	R	R	R	R	R	R	R	R	R
Bit	15	14	13	12	11	10	9	8	7	6	5	4	3	2	1	0
	mac_da_uni[47:32]															
Initial Value	0	0	0	0	0	0	0	0	0	0	0	0	0	0	0	0
R/W	R/W	R/W	R/W	R/W	R/W	R/W	R/W	R/W	R/W	R/W	R/W	R/W	R/W	R/W	R/W	R/W

Bit	Bit Name	Initial Value	R/W	Description
31 to 16	—	All 0	R	Reserved Whenever it is read, 0 is read. The written value will be ignored.
15 to 0	mac_da_uni	H'0000	R/W	MAC DA unicast address Configuration of the MAC DA unicast Address [47:32] for Filter Condition and Interrupt Condition. Write to this field when CSFR15.mac_da_uni_en = "0".

30.4.3.23 Lower MAC DA unicast address Condition register (CSFR13_L)

Bit	31	30	29	28	27	26	25	24	23	22	21	20	19	18	17	16
	mac_da_uni[31:16]															
Initial Value	0	0	0	0	0	0	0	0	0	0	0	0	0	0	0	0
R/W	R/W	R/W	R/W	R/W	R/W	R/W	R/W	R/W	R/W	R/W	R/W	R/W	R/W	R/W	R/W	R/W
Bit	15	14	13	12	11	10	9	8	7	6	5	4	3	2	1	0
	mac_da_uni[15:0]															
Initial Value	0	0	0	0	0	0	0	0	0	0	0	0	0	0	0	0
R/W	R/W	R/W	R/W	R/W	R/W	R/W	R/W	R/W	R/W	R/W	R/W	R/W	R/W	R/W	R/W	R/W

Bit	Bit Name	Initial Value	R/W	Description
31 to 0	mac_da_uni	H'0000_0000	R/W	MAC DA Unicast address Configuration of the MAC DA unicast Address [31:0] for Filter Condition and Interrupt Condition. Write to this field when CSFR15.mac_da_uni_en = "0".

30.4.3.24 Upper MAC DA broadcast address Condition register (CSFR14_U)

Bit	31	30	29	28	27	26	25	24	23	22	21	20	19	18	17	16
	[Reserved]															
Initial Value	0	0	0	0	0	0	0	0	0	0	0	0	0	0	0	0
R/W	R	R	R	R	R	R	R	R	R	R	R	R	R	R	R	R
Bit	15	14	13	12	11	10	9	8	7	6	5	4	3	2	1	0
	mac_da_bro[47:40]															
Initial Value	1	1	1	1	1	1	1	1	1	1	1	1	1	1	1	1
R/W	R/W	R/W	R/W	R/W	R/W	R/W	R/W	R/W	R/W	R/W	R/W	R/W	R/W	R/W	R/W	R/W

Bit	Bit Name	Initial Value	R/W	Description
31 to 16	—	All 0	R	Reserved Whenever it is read, 0 is read. The written value will be ignored.
15 to 0	mac_da_bro	H'FFFF	R/W	MAC DA Broadcast address Configuration of the MAC DA broadcast Address [47:32] for Filter Condition and Interrupt Condition. Write to this field when CSFR15.mac_da_bro_en = "0".

30.4.3.25 Lower MAC DA broadcast address Condition register (CSFR14_L)

Bit	31	30	29	28	27	26	25	24	23	22	21	20	19	18	17	16
	mac_da_bro[31:16]															
Initial Value	1	1	1	1	1	1	1	1	1	1	1	1	1	1	1	1
R/W	R/W	R/W	R/W	R/W	R/W	R/W	R/W	R/W	R/W	R/W	R/W	R/W	R/W	R/W	R/W	R/W
Bit	15	14	13	12	11	10	9	8	7	6	5	4	3	2	1	0
	mac_da_bro[15:0]															
Initial Value	1	1	1	1	1	1	1	1	1	1	1	1	1	1	1	1
R/W	R/W	R/W	R/W	R/W	R/W	R/W	R/W	R/W	R/W	R/W	R/W	R/W	R/W	R/W	R/W	R/W

Bit	Bit Name	Initial Value	R/W	Description
31 to 0	mac_da_bro	H'FFFF_F FFF	R/W	MAC DA Broadcast address Configuration of the MAC DA broadcast Address [31:0] for Filter Condition and Interrupt Condition. Write to this field when CSFR15.mac_da_bro_en = "0".

30.4.3.26 Upper MAC DA multicast address Condition register i (i = 0 to 19) (CSFR15_U_i)

Bit	31	30	29	28	27	26	25	24	23	22	21	20	19	18	17	16
	—	—	—	—	—	—	—	—	—	—	—	—	—	—	—	—
Initial Value	0	0	0	0	0	0	0	0	0	0	0	0	0	0	0	0
R/W	R	R	R	R	R	R	R	R	R	R	R	R	R	R	R	R
Bit	15	14	13	12	11	10	9	8	7	6	5	4	3	2	1	0
	mac_da_mul_i[47:32]															
Initial Value	0	0	0	0	0	0	0	1	0	0	0	0	0	0	0	0
R/W	R/W	R/W	R/W	R/W	R/W	R/W	R/W	R/W	R/W	R/W	R/W	R/W	R/W	R/W	R/W	R/W

Bit	Bit Name	Initial Value	R/W	Description
31 to 16	—	All 0	R	Reserved Whenever it is read, 0 is read. The written value will be ignored.
15 to 0	mac_da_mul_i	H'0100	R/W	MAC DA Multicast address Configuration of the MAC DA multicast Address [47:32] for Filter Condition and Interrupt Condition. Write to this field when CSFR15.mac_da_mul_i_en = "0".

30.4.3.27 Lower MAC DA multicast address Condition register i (i = 0 to 19) (CSFR15_L_i)

Bit	31	30	29	28	27	26	25	24	23	22	21	20	19	18	17	16
	mac_da_mul_i[31:16]															
Initial Value	0	1	0	1	1	1	1	0	0	0	0	0	0	0	0	0
R/W	R/W	R/W	R/W	R/W	R/W	R/W	R/W	R/W	R/W	R/W	R/W	R/W	R/W	R/W	R/W	R/W
Bit	15	14	13	12	11	10	9	8	7	6	5	4	3	2	1	0
	mac_da_mul_i[15:0]															
Initial Value	0	0	0	0	0	0	0	0	0	0	0	0	0	0	0	0
R/W	R/W	R/W	R/W	R/W	R/W	R/W	R/W	R/W	R/W	R/W	R/W	R/W	R/W	R/W	R/W	R/W

Bit	Bit Name	Initial Value	R/W	Description
31 to 0	mac_da_mul_i	H'5E00_000	R/W	MAC DA Multicast address Configuration of the MAC DA multicast Address [31:0] for Filter Condition and Interrupt Condition. Write to this field when CSFR15.mac_da_mul_i_en = "0".

30.4.3.28 MAC DA Condition Enable register (CSFR15)

Bit	31	30	29	28	27	26	25	24	23	22	21	20	19	18	17	16
	—	—	—	mac_da_uni_en	—	—	—	mac_da_bro_en	—	—	—	—	mac_da_mul_19_en	mac_da_mul_18_en	mac_da_mul_17_en	mac_da_mul_16_en
Initial Value	0	0	0	0	0	0	0	0	0	0	0	0	0	0	0	0
R/W	R	R	R	R/W	R	R	R	R/W	R	R	R	R	R/W	R/W	R/W	R/W
Bit	15	14	13	12	11	10	9	8	7	6	5	4	3	2	1	0
	mac_da_mul_15_en	mac_da_mul_14_en	mac_da_mul_13_en	mac_da_mul_12_en	mac_da_mul_11_en	mac_da_mul_10_en	mac_da_mul_9_en	mac_da_mul_8_en	mac_da_mul_7_en	mac_da_mul_6_en	mac_da_mul_5_en	mac_da_mul_4_en	mac_da_mul_3_en	mac_da_mul_2_en	mac_da_mul_1_en	mac_da_mul_0_en
Initial Value	0	0	0	0	0	0	0	0	0	0	0	0	0	0	0	0
R/W	R/W	R/W	R/W	R/W	R/W	R/W	R/W	R/W	R/W	R/W	R/W	R/W	R/W	R/W	R/W	R/W

Bit	Bit Name	Initial Value	R/W	Description
31 to 29	—	All 0	R	Reserved Whenever it is read, 0 is read. The written value will be ignored.
28	mac_da_uni_en	0b	R/W	Mac_da_uni enable Enable for the value of mac_da_uni which is configured in CSFR13_U/L. 0b: Disable 1b: Enable
27 to 25	—	All 0	R	Reserved Whenever it is read, 0 is read. The written value will be ignored.
24	mac_da_bro_en	0b	R/W	Mac_da_bro enable Enable for the value of mac_da_bro which is configured in CSFR14_U/L. 0b: Disable 1b: Enable
23 to 20	—	All 0	R	Reserved Whenever it is read, 0 is read. The written value will be ignored.
19	mac_da_mul_19_en	0b	R/W	mac_da_mul_19 enable Enable for the value of mac_da_mul_19 which is configured in CSFR15_U/L. 0b: Disable 1b: Enable
18	mac_da_mul_18_en	0b	R/W	mac_da_mul_18 enable Enable for the value of mac_da_mul_18 which is configured in CSFR15_U/L. 0b: Disable 1b: Enable
17	mac_da_mul_17_en	0b	R/W	mac_da_mul_17 enable Enable for the value of mac_da_mul_17 which is configured in CSFR15_U/L. 0b: Disable 1b: Enable
16	mac_da_mul_16_en	0b	R/W	mac_da_mul_16 enable Enable for the value of mac_da_mul_16 which is configured in CSFR15_U/L. 0b: Disable 1b: Enable
15	mac_da_mul_15_en	0b	R/W	mac_da_mul_15 enable Enable for the value of mac_da_mul_15 which is configured in CSFR15_U/L. 0b: Disable 1b: Enable

Bit	Bit Name	Initial Value	R/W	Description
14	mac_da_mul_14_en	0b	R/W	mac_da_mul_14 enable Enable for the value of mac_da_mul_14 which is configured in CSFR15_U/L. 0b: Disable 1b: Enable
13	mac_da_mul_13_en	0b	R/W	mac_da_mul_13 enable Enable for the value of mac_da_mul_13 which is configured in CSFR15_U/L. 0b: Disable 1b: Enable
12	mac_da_mul_12_en	0b	R/W	mac_da_mul_12 enable Enable for the value of mac_da_mul_12 which is configured in CSFR15_U/L. 0b: Disable 1b: Enable
11	mac_da_mul_11_en	0b	R/W	mac_da_mul_11 enable Enable for the value of mac_da_mul_11 which is configured in CSFR15_U/L. 0b: Disable 1b: Enable
10	mac_da_mul_10_en	0b	R/W	mac_da_mul_10 enable Enable for the value of mac_da_mul_10 which is configured in CSFR15_U/L. 0b: Disable 1b: Enable
9	mac_da_mul_9_en	0b	R/W	mac_da_mul_9 enable Enable for the value of mac_da_mul_9 which is configured in CSFR15_U/L. 0b: Disable 1b: Enable
8	mac_da_mul_8_en	0b	R/W	mac_da_mul_8 enable Enable for the value of mac_da_mul_8 which is configured in CSFR15_U/L. 0b: Disable 1b: Enable
7	mac_da_mul_7_en	0b	R/W	mac_da_mul_7 enable Enable for the value of mac_da_mul_7 which is configured in CSFR15_U/L. 0b: Disable 1b: Enable
6	mac_da_mul_6_en	0b	R/W	mac_da_mul_6 enable Enable for the value of mac_da_mul_6 which is configured in CSFR15_U/L. 0b: Disable 1b: Enable
5	mac_da_mul_5_en	0b	R/W	mac_da_mul_5 enable Enable for the value of mac_da_mul_5 which is configured in CSFR15_U/L. 0b: Disable 1b: Enable
4	mac_da_mul_4_en	0b	R/W	mac_da_mul_4 enable Enable for the value of mac_da_mul_4 which is configured in CSFR15_U/L. 0b: Disable 1b: Enable
3	mac_da_mul_3_en	0b	R/W	mac_da_mul_3 enable Enable for the value of mac_da_mul_3 which is configured in CSFR15_U/L. 0b: Disable 1b: Enable
2	mac_da_mul_2_en	0b	R/W	mac_da_mul_2 enable Enable for the value of mac_da_mul_2 which is configured in CSFR15_U/L. 0b: Disable 1b: Enable

Bit	Bit Name	Initial Value	R/W	Description
1	mac_da_mul_1_en	0b	R/W	mac_da_mul_1 enable Enable for the value of mac_da_mul_1 which is configured in CSFR15_U/L. 0b: Disable 1b: Enable
0	mac_da_mul_0_en	0b	R/W	mac_da_mul_0 enable Enable for the value of mac_da_mul_0 which is configured in CSFR15_U/L. 0b: Disable 1b: Enable

30.4.3.29 IPv6 analysis Protocol Condition register 0 (CSFR16_0)

Bit	31	30	29	28	27	26	25	24	23	22	21	20	19	18	17	16
	v6_ana_protocol_3[7:0]								v6_ana_protocol_2[7:0]							
Initial Value	0	0	1	0	1	0	0	1	0	0	0	1	0	0	0	1
R/W	R/W	R/W	R/W	R/W	R/W	R/W	R/W	R/W	R/W	R/W	R/W	R/W	R/W	R/W	R/W	R/W
Bit	15	14	13	12	11	10	9	8	7	6	5	4	3	2	1	0
	v6_ana_protocol_1[7:0]								v6_ana_protocol_0[7:0]							
Initial Value	0	0	0	0	0	1	1	0	0	0	0	0	0	0	0	0
R/W	R/W	R/W	R/W	R/W	R/W	R/W	R/W	R/W	R/W	R/W	R/W	R/W	R/W	R/W	R/W	R/W

Bit	Bit Name	Initial Value	R/W	Description
31 to 24	v6_ana_protocol_3	H'29	R/W	IPv6 Analyzable Protocol No 3 IPv6 protocol No to continue analysis in the Frame analysis procedure of Filter and Interrupt. Initial value is H'29 IPV6 (41). Write to this field when CSFR16. v6_ana_protocol_3_en is '0b'.
23 to 16	v6_ana_protocol_2	H'11	R/W	IPv6 Analyzable Protocol No 2 IPv6 protocol No to continue analysis in the Frame analysis procedure of Filter and Interrupt. Initial value is H'11 UDP (17). Write to this field when CSFR16. v6_ana_protocol_2_en is '0b'.
15 to 8	v6_ana_protocol_1	H'06	R/W	IPv6 Analyzable Protocol No 1 IPv6 protocol No to continue analysis in the Frame analysis procedure of Filter and Interrupt. Initial value is H'06 TCP (6). Write to this field when CSFR16. v6_ana_protocol_1_en is '0b'.
7 to 0	v6_ana_protocol_0	H'00	R/W	IPv6 Analyzable Protocol No 0 IPv6 protocol No to continue analysis in the Frame analysis procedure of Filter and Interrupt. Initial value is H'00 Hop-by-Hop (0). Write to this field when CSFR16. v6_ana_protocol_0_en is '0b'.

30.4.3.30 IPv6 analysis Protocol Condition register 1 (CSFR16_1)

Bit	31	30	29	28	27	26	25	24	23	22	21	20	19	18	17	16
	v6_ana_protocol_7[7:0]								v6_ana_protocol_6[7:0]							
Initial Value	0	0	1	1	1	0	1	0	0	0	1	1	0	0	1	1
R/W	R/W	R/W	R/W	R/W	R/W	R/W	R/W	R/W	R/W	R/W	R/W	R/W	R/W	R/W	R/W	R/W
Bit	15	14	13	12	11	10	9	8	7	6	5	4	3	2	1	0
	v6_ana_protocol_5[7:0]								v6_ana_protocol_4[7:0]							
Initial Value	0	0	1	0	1	1	0	0	0	0	1	0	1	0	1	1
R/W	R/W	R/W	R/W	R/W	R/W	R/W	R/W	R/W	R/W	R/W	R/W	R/W	R/W	R/W	R/W	R/W

Bit	Bit Name	Initial Value	R/W	Description
31 to 24	v6_ana_protocol_7	H'3A	R/W	IPv6 Analyzable Protocol No.7 IPv6 protocol No to continue analysis in the Frame analysis procedure of Filter and Interrupt. Initial value is H'3A ICMPv6 (58). Write to this field when CSFR16. v6_ana_protocol_7_en is '0b'.
23 to 16	v6_ana_protocol_6	H'33	R/W	IPv6 Analyzable Protocol No.6 IPv6 protocol No to continue analysis in the Frame analysis procedure of Filter and Interrupt. Initial value is H'33 Authentication (51). Write to this field when CSFR16. v6_ana_protocol_6_en is '0b'.
15 to 8	v6_ana_protocol_5	H'2C	R/W	IPv6 Analyzable Protocol No.5 IPv6 protocol No to continue analysis in the Frame analysis procedure of Filter and Interrupt. Initial value is H'2C Flag (44). Write to this field when CSFR16. v6_ana_protocol_5_en is '0b'.
7 to 0	v6_ana_protocol_4	H'2B	R/W	IPv6 Analyzable Protocol No.4 IPv6 protocol No to continue analysis in the Frame analysis procedure of Filter and Interrupt. Initial value is H'2B Routing (43). Write to this field when CSFR16. v6_ana_protocol_4_en is '0b'.

30.4.3.31 IPv6 analysis Protocol Condition register 2 (CSFR16_2)

Bit	31	30	29	28	27	26	25	24	23	22	21	20	19	18	17	16
	—	—	—	—	—	—	—	—	—	—	—	—	—	—	—	—
Initial Value	0	0	0	0	0	0	0	0	0	0	0	0	0	0	0	0
R/W	R	R	R	R	R	R	R	R	R	R	R	R	R	R	R	R
Bit	15	14	13	12	11	10	9	8	7	6	5	4	3	2	1	0
	—	—	—	—	—	—	—	—	v6_ana_protocol_8[7:0]							
Initial Value	0	0	0	0	0	0	0	0	0	0	1	1	1	1	0	0
R/W	R	R	R	R	R	R	R	R	R/W	R/W	R/W	R/W	R/W	R/W	R/W	R/W

Bit	Bit Name	Initial Value	R/W	Description
31 to 8	—	All 0	R	Reserved Whenever it is read, 0 is read. The written value will be ignored.
7 to 0	v6_ana_protocol_8	H'3C	R/W	IPv6 Analyzable Protocol No 8 IPv6 protocol No to continue analysis in the Frame analysis procedure of Filter and Interrupt. Initial value is H'3C Destination Options (60). Write to this field when CSFR16. v6 ana protocol 8 en is '0b'.

30.4.3.32 IPv6 analysis Protocol Condition Enable register (CSFR16)

Bit	31	30	29	28	27	26	25	24	23	22	21	20	19	18	17	16
	—	—	—	—	—	—	—	—	—	—	—	—	—	—	—	—
Initial Value	0	0	0	0	0	0	0	0	0	0	0	0	0	0	0	0
R/W	R	R	R	R	R	R	R	R	R	R	R	R	R	R	R	R
Bit	15	14	13	12	11	10	9	8	7	6	5	4	3	2	1	0
	—	—	—	—	—	—	—	v6_ana_protocol_8_en	v6_ana_protocol_7_en	v6_ana_protocol_6_en	v6_ana_protocol_5_en	v6_ana_protocol_4_en	v6_ana_protocol_3_en	v6_ana_protocol_2_en	v6_ana_protocol_1_en	v6_ana_protocol_0_en
Initial Value	0	0	0	0	0	0	0	1	1	1	1	1	1	1	1	1
R/W	R	R	R	R	R	R	R	R/W	R/W	R/W	R/W	R/W	R/W	R/W	R/W	R/W

Bit	Bit Name	Initial Value	R/W	Description
31 to 9	—	All 0	R	Reserved Whenever it is read, 0 is read. The written value will be ignored.
8	v6_ana_protocol_8_en	1b	R/W	v6_ana_protocol_8 enable Enable for the value of v6_ana_protocol_8 which is configured in CSFR16_i. 0b: Disable 1b: Enable
7	v6_ana_protocol_7_en	1b	R/W	v6_ana_protocol_7 enable Enable for the value of v6_ana_protocol_7 which is configured in CSFR16_i. 0b: Disable 1b: Enable
6	v6_ana_protocol_6_en	1b	R/W	v6_ana_protocol_6 enable Enable for the value of v6_ana_protocol_6 which is configured in CSFR16_i. 0b: Disable 1b: Enable
5	v6_ana_protocol_5_en	1b	R/W	v6_ana_protocol_5 enable Enable for the value of v6_ana_protocol_5 which is configured in CSFR16_i. 0b: Disable 1b: Enable
4	v6_ana_protocol_4_en	1b	R/W	v6_ana_protocol_4 enable Enable for the value of v6_ana_protocol_4 which is configured in CSFR16_i. 0b: Disable 1b: Enable
3	v6_ana_protocol_3_en	1b	R/W	v6_ana_protocol_3 enable Enable for the value of v6_ana_protocol_3 which is configured in CSFR16_i. 0b: Disable 1b: Enable
2	v6_ana_protocol_2_en	1b	R/W	v6_ana_protocol_2 enable Enable for the value of v6_ana_protocol_2 which is configured in CSFR16_i. 0b: Disable 1b: Enable
1	v6_ana_protocol_1_en	1b	R/W	v6_ana_protocol_1 enable Enable for the value of v6_ana_protocol_1 which is configured in CSFR16_i. 0b: Disable 1b: Enable
0	v6_ana_protocol_0_en	1b	R/W	v6_ana_protocol_0 enable Enable for the value of v6_ana_protocol_0 which is configured in CSFR16_i. 0b: Disable 1b: Enable

30.4.3.33 Wake Up Interrupt Status register (CSFR20)

Bit	31	30	29	28	27	26	25	24	23	22	21	20	19	18	17	16
	—	—	—	trs_dmac	—	—	—	—	—	—	—	ieee_len	ns_dis	ns_dup	ns_uni_nopt	ns_uni
Initial Value	0	0	0	0	0	0	0	0	0	0	0	0	0	0	0	0
R/W	R	R	R	R/W	R	R	R	R	R	R	R	R/W	R/W	R/W	R/W	R/W
Bit	15	14	13	12	11	10	9	8	7	6	5	4	3	2	1	0
	ns_mul	ana_stp	v6_ana_protocol	arp_noreq	garp_self	garp_other	arp_self	arp_other	v6_udp_pt	v4_udp_pt	v6_protocol	v4_protocol	type	mac_da_mul	mac_da_bro	mac_da_uni
Initial Value	0	0	0	0	0	0	0	0	0	0	0	0	0	0	0	0
R/W	R/W	R/W	R/W	R/W	R/W	R/W	R/W	R/W	R/W	R/W	R/W	R/W	R/W	R/W	R/W	R/W

Bit	Bit Name	Initial Value	R/W	Description
31 to 29	—	All 0	R	Reserved Whenever it is read, 0 is read. The written value will be ignored.
28	trs_dmac	0b	R/W	Transmit to DMAC Wake Up Interrupt which occurs by transmitting Frame from TOE to DMAC without discarding of filtering '1' Write: Clear '0' Write: Invalid
27 to 21	—	All 0	R	Reserved Whenever it is read, 0 is read. The written value will be ignored.
20	ieee_len	0b	R/W	IEEE Length filter Wake Up Interrupt which occurs by reception of IEEE802.3 Length Frame '1' Write: Clear '0' Write: Invalid
19	ns_dis	0b	R/W	Neighbor Solicitation discarded filter Wake Up Interrupt which occurs by reception of Invalid Neighbor Solicitations '1' Write: Clear '0' Write: Invalid
18	ns_dup	0b	R/W	Neighbor Solicitation Duplicate filter Wake Up Interrupt which occurs by reception of IP Duplicate Detection Neighbor Solicitations. '1' Write: Clear '0' Write: Invalid
17	ns_uni_nopt	0b	R/W	Neighbor Solicitation Unicast no option filter Wake Up Interrupt which occurs by reception of unicast Neighbor Solicitations (Except "Option Type=1" or No "Option Type"). '1' Write: Clear '0' Write: Invalid
16	ns_uni	0b	R/W	Neighbor Solicitation Unicast filter Wake Up Interrupt which occurs by reception of unicast Neighbor Solicitations ("Option Type=1"). '1' Write: Clear '0' Write: Invalid
15	ns_mul	0b	R/W	Neighbor Solicitation Multicast filter Wake Up Interrupt which occurs by reception of multicast Neighbor Solicitations. '1' Write: Clear '0' Write: Invalid

Bit	Bit Name	Initial Value	R/W	Description
14	ana_stp	0b	R/W	Analysis stop filter Wake Up Interrupt which occurs by reception of Un-analyzable Frames. '1' Write: Clear '0' Write: Invalid
13	v6_ana_protocol	0b	R/W	IPv6 Analysis protocol filter Wake Up Interrupt which occurs by reception of Un-analyzable IPv6 Protocol No. '1' Write: Clear '0' Write: Invalid
12	arp_noreq	0b	R/W	ARP no request filter Wake Up Interrupt which occurs by reception of ARP (Except ARP REQ). '1' Write: Clear '0' Write: Invalid
11	garp_self	0b	R/W	GARP self-filter Wake Up Interrupt which occurs by reception of GARP REQ for Local Station. '1' Write: Clear '0' Write: Invalid
10	garp_other	0b	R/W	GARP other filter Wake Up Interrupt which occurs by reception of GARP REQ for Other Station. '1' Write: Clear '0' Write: Invalid
9	arp_self	0b	R/W	ARP self-filter Wake Up Interrupt which occurs by reception of ARP REQ for Local Station. '1' Write: Clear '0' Write: Invalid
8	arp_other	0b	R/W	ARP other filter Wake Up Interrupt which occurs by reception of ARP REQ for Other Station. '1' Write: Clear '0' Write: Invalid
7	v6_udp_pt	0b	R/W	IPv6 UDP port filter Wake Up Interrupt which occurs by match of IPv6 UDP Port No. '1' Write: Clear '0' Write: Invalid
6	v4_udp_pt	0b	R/W	IPv4 UDP port filter Wake Up Interrupt which occurs by match of IPv4 UDP Port No. '1' Write: Clear '0' Write: Invalid
5	v6_protocol	0b	R/W	IPv6 protocol filter Wake Up Interrupt which occurs by match of IPv6 Protocol No. '1' Write: Clear '0' Write: Invalid
4	v4_protocol	0b	R/W	IPv4 protocol filter Wake Up Interrupt which occurs by match of IPv4 Protocol No. '1' Write: Clear '0' Write: Invalid
3	type	0b	R/W	Type filter Wake Up Interrupt which occurs by match of Ether Type. '1' Write: Clear '0' Write: Invalid
2	mac_da_mul	0b	R/W	MAC DA multicast filter Wake Up Interrupt which occurs by match of Multicast MAC DA. '1' Write: Clear '0' Write: Invalid

Bit	Bit Name	Initial Value	R/W	Description
1	mac_da_bro	0b	R/W	MAC DA broadcast filter Wake Up Interrupt which occurs by match of Broadcast MAC DA. '1' Write: Clear '0' Write: Invalid
0	mac_da_uni	0b	R/W	MAC DA unicast filter Wake Up Interrupt which occurs by match of Unicast MAC DA. '1' Write: Clear '0' Write: Invalid

NOTE

- From b[0] to b[20] are set to "1" when TOE received the Rx Frame which matches to Filter Conditions even if that frame has any error (such as CRC error, short length error or etc.). Therefore, use these bits only for Debug.
- b [28] is set to "1" only when TOE sent a normal Rx Frame to DMAC.

30.4.3.34 Wake Up Interrupt Mask register (CSFR21)

Bit	31	30	29	28	27	26	25	24	23	22	21	20	19	18	17	16
	—	—	—	trs_dmac_m	—	—	—	—	—	—	—	ieee_len_m	ns_dis_m	ns_dup_m	ns_uni_nopt_m	ns_uni_m
Initial Value	0	0	0	1	0	0	0	0	0	0	0	1	1	1	1	1
R/W	R	R	R	R/W	R	R	R	R	R	R	R	R/W	R/W	R/W	R/W	R/W
Bit	15	14	13	12	11	10	9	8	7	6	5	4	3	2	1	0
	ns_mul_m	ana_stp_m	v6_ana_protocol_m	arp_noreq_m	garp_sel_f_m	garp_other_m	arp_self_m	arp_other_m	v6_udp_pt_m	v4_udp_pt_m	v6_protocol_m	v4_protocol_m	type_m	mac_da_mul_m	mac_da_bro_m	mac_da_uni_m
Initial Value	1	1	1	1	1	1	1	1	1	1	1	1	1	1	1	1
R/W	R/W	R/W	R/W	R/W	R/W	R/W	R/W	R/W	R/W	R/W	R/W	R/W	R/W	R/W	R/W	R/W

Bit	Bit Name	Initial Value	R/W	Description
31 to 29	—	All 0	R	Reserved Whenever it is read, 0 is read. The written value will be ignored.
28	trs_dmac_m	1b	R/W	Transmit to DMAC Mask Mask Configuration for Wake-Up Interrupt which occurs by transmitting Frame from TOE to DMAC without discarding of filtering 0b: Non-Mask (Interrupt is asserted) 1b: Mask (Interrupt is not asserted)
27 to 21	—	All 0	R	Reserved Whenever it is read, 0 is read. The written value will be ignored.
20	ieee_len_m	1b	R/W	IEEE Length filter Mask Mask Configuration for Wake-Up Interrupt which occurs by reception of IEEE802.3 Length Frame 0b: Non-Mask (Interrupt is asserted) 1b: Mask (Interrupt is not asserted)
19	ns_dis_m	1b	R/W	Neighbor Solicitation discarded filter Mask Mask Configuration for Wake-Up Interrupt which occurs by reception of Invalid Neighbor Solicitations 0b: Non-Mask (Interrupt is asserted) 1b: Mask (Interrupt is not asserted)
18	ns_dup_m	1b	R/W	Neighbor Solicitation Duplicate filter Mask Mask Configuration for Wake-Up Interrupt which occurs by reception of IP Duplicate Detection Neighbor Solicitations. 0b: Non-Mask (Interrupt is asserted) 1b: Mask (Interrupt is not asserted)
17	ns_uni_nopt_m	1b	R/W	Neighbor Solicitation Unicast no option filter Mask Mask Configuration for Wake-Up Interrupt which occurs by reception of unicast Neighbor Solicitations (Except "Option Type=1" or No "Option Type"). 0b: Non-Mask (Interrupt is asserted) 1b: Mask (Interrupt is not asserted)
16	ns_uni_m	1b	R/W	Neighbor Solicitation Unicast filter Mask Mask Configuration for Wake-Up Interrupt which occurs by reception of unicast Neighbor Solicitations ("Option Type=1"). 0b: Non-Mask (Interrupt is asserted) 1b: Mask (Interrupt is not asserted)
15	ns_mul_m	1b	R/W	Neighbor Solicitation Multicast filter Mask Mask Configuration for Wake-Up Interrupt which occurs by reception of multicast Neighbor Solicitations. 0b: Non-Mask (Interrupt is asserted) 1b: Mask (Interrupt is not asserted)

Bit	Bit Name	Initial Value	R/W	Description
14	ana_stp_m	1b	R/W	Analysis stop filter Mask Mask Configuration for Wake-Up Interrupt which occurs by reception of Un-analyzable Frames. 0b: Non-Mask (Interrupt is asserted) 1b: Mask (Interrupt is not asserted)
13	v6_ana_proto_col_m	1b	R/W	IPv6 Analysis protocol filter Mask Mask Configuration for Wake-Up Interrupt which occurs by reception of Un-analyzable IPv6 Protocol No. 0b: Non-Mask (Interrupt is asserted) 1b: Mask (Interrupt is not asserted)
12	arp_noreq_m	1b	R/W	ARP no request filter Mask Mask Configuration for Wake-Up Interrupt which occurs by reception of ARP (Except ARP REQ). 0b: Non-Mask (Interrupt is asserted) 1b: Mask (Interrupt is not asserted)
11	garp_self_m	1b	R/W	GARP self-filter Mask Mask Configuration for Wake-Up Interrupt which occurs by reception of GARP REQ for Local Station. 0b: Non-Mask (Interrupt is asserted) 1b: Mask (Interrupt is not asserted)
10	garp_other_m	1b	R/W	GARP other filter Mask Mask Configuration for Wake-Up Interrupt which occurs by reception of GARP REQ for Other Station. 0b: Non-Mask (Interrupt is asserted) 1b: Mask (Interrupt is not asserted)
9	arp_self_m	1b	R/W	ARP self-filter Mask Mask Configuration for Wake-Up Interrupt which occurs by reception of ARP REQ for Local Station. 0b: Non-Mask (Interrupt is asserted) 1b: Mask (Interrupt is not asserted)
8	arp_other_m	1b	R/W	ARP other filter Mask Mask Configuration for Wake-Up Interrupt which occurs by reception of ARP REQ for Other Station. 0b: Non-Mask (Interrupt is asserted) 1b: Mask (Interrupt is not asserted)
7	v6_udp_pt_m	1b	R/W	IPv6 UDP port filter Mask Mask Configuration for Wake-Up Interrupt which occurs by match of IPv6 UDP Port No. 0b: Non-Mask (Interrupt is asserted) 1b: Mask (Interrupt is not asserted)
6	v4_udp_pt_m	1b	R/W	IPv4 UDP port filter Mask Mask Configuration for Wake-Up Interrupt which occurs by match of IPv4 UDP Port No. 0b: Non-Mask (Interrupt is asserted) 1b: Mask (Interrupt is not asserted)
5	v6_protocol_m	1b	R/W	IPv6 protocol filter Mask Mask Configuration for Wake-Up Interrupt which occurs by match of IPv6 Protocol No. 0b: Non-Mask (Interrupt is asserted) 1b: Mask (Interrupt is not asserted)
4	v4_protocol_m	1b	R/W	IPv4 protocol filter Mask Mask Configuration for Wake-Up Interrupt which occurs by match of IPv4 Protocol No. 0b: Non-Mask (Interrupt is asserted) 1b: Mask (Interrupt is not asserted)

Bit	Bit Name	Initial Value	R/W	Description
3	type_m	1b	R/W	Type filter Mask Mask Configuration for Wake-Up Interrupt which occurs by match of Ether Type. 0b: Non-Mask (Interrupt is asserted) 1b: Mask (Interrupt is not asserted)
2	mac_da_mul_m	1b	R/W	MAC DA multicast filter Mask Mask Configuration for Wake-Up Interrupt which occurs by match of Multicast MAC DA. 0b: Non-Mask (Interrupt is asserted) 1b: Mask (Interrupt is not asserted)
1	mac_da_bro_m	1b	R/W	MAC DA broadcast filter Mask Mask Configuration for Wake-Up Interrupt which occurs by match of Broadcast MAC DA. 0b: Non-Mask (Interrupt is asserted) 1b: Mask (Interrupt is not asserted)
0	mac_da_uni_m	1b	R/W	MAC DA unicast filter Mask Mask Configuration for Wake-Up Interrupt which occurs by match of Unicast MAC DA. 0b: Non-Mask (Interrupt is asserted) 1b: Mask (Interrupt is not asserted)

30.4.3.35 Auto Response Configuration register1 (CSFR30)

Bit	31	30	29	28	27	26	25	24	23	22	21	20	19	18	17	16
	—	—	—	—	—	—	—	—	—	—	—	—	—	—	—	na_dup_of
Initial Value	0	0	0	0	0	0	0	0	0	0	0	0	0	0	0	1
R/W	R	R	R	R	R	R	R	R	R	R	R	R	R	R	R	R/W
Bit	15	14	13	12	11	10	9	8	7	6	5	4	3	2	1	0
	ns_dup_int_en	ns_uni_nopt_int_en	ns_uni_int_en	ns_mul_int_en	ns_dup_reply_en	—	ns_uni_reply_en	ns_mul_reply_en	—	garp_sel_f_int_en	garp_other_int_en	arp_self_int_en	—	garp_sel_f_reply_en	—	arp_self_reply_en
Initial Value	0	1	1	1	1	0	1	1	0	0	1	1	0	1	0	1
R/W	R/W	R/W	R/W	R/W	R/W	R	R/W	R/W	R	R/W	R/W	R/W	R	R/W	R	R/W

Bit	Bit Name	Initial Value	R/W	Description
31 to 17	—	All 0	R	Reserved Whenever it is read, 0 is read. The written value will be ignored.
16	na_dup_of	1b	R/W	Neighbor Advertisement Duplicate Override flag Configuration of Override flag to Auto Response Neighbor Advertisements when the reception of IP Duplicate Detection Neighbor Solicitation for Local Station. Usually, do not change this bit. Keep initial values "1b". 0b: Override flag is set as 0 1b: Override flag is set as 1
15	ns_dup_int_en	0b	R/W	Neighbor Solicitation Duplicate interrupt enable Enable of Interrupt which occurs by reception of IP Duplicate Detection Neighbor Solicitations for Local Station. 0b: Disable 1b: Enable
14	ns_uni_nopt_int_en	1b	R/W	Neighbor Solicitation Unicast no option interrupt enable Enable of Interrupt which occurs by reception of Unicast Neighbor Solicitations for Local Station (Except "Option Type=1" or No "Option Type"). 0b: Disable 1b: Enable
13	ns_uni_int_en	1b	R/W	Neighbor Solicitation Unicast interrupt enable Enable of Interrupt which occurs by reception of Unicast Neighbor Solicitations for Local Station (Option Type=1). 0b: Disable 1b: Enable
12	ns_mul_int_en	1b	R/W	Neighbor Solicitation Multicast interrupt enable Enable of Interrupt which occurs by reception of Multicast Neighbor Solicitations for Local Station. 0b: Disable 1b: Enable
11	ns_dup_reply_en	1b	R/W	Neighbor Solicitation Duplicate reply enable Enable of Auto Response for reception of IP Duplicate Detection Neighbor Solicitations for Local Station. 0b: Disable 1b: Enable
10	—	0b	R	Reserved Whenever it is read, 0 is read. The written value will be ignored.

Bit	Bit Name	Initial Value	R/W	Description
9	ns_uni_reply_en	1b	R/W	Neighbor Solicitation Unicast reply enable Enable of Auto Response for reception of Unicast Neighbor Solicitations (Option Type=1) for Local Station. 0b: Disable 1b: Enable
8	ns_mul_reply_en	1b	R/W	Neighbor Solicitation Multicast reply enable Enable of Auto Response for reception of Multicast Neighbor Solicitations for Local Station. 0b: Disable 1b: Enable
7	—	0b	R	Reserved T Whenever it is read, 0 is read. The written value will be ignored.
6	garp_self_int_en	0b	R/W	GARP self-interrupt enable Enable of Interrupt which occurs by reception of GARP REQ for Local Station. 0b: Disable 1b: Enable
5	garp_other_int_en	1b	R/W	GARP other interrupt enable Enable of Interrupt which occurs by reception of GARP REQ for Other Station. 0b: Disable 1b: Enable
4	arp_self_int_en	1b	R/W	ARP self-interrupt enable Enable of Interrupt which occurs by reception of ARP REQ for Local Station. 0b: Disable 1b: Enable
3	—	0b	R	Reserved Whenever it is read, 0 is read. The written value will be ignored.
2	garp_self_reply_en	1b	R/W	GARP self reply enable Enable of Auto Response for reception of GARP REQ for Local Station. 0b: Disable 1b: Enable
1	—	0b	R	Reserved Whenever it is read, 0 is read. The written value will be ignored.
0	arp_self_reply_en	1b	R/W	ARP self reply enable Enable of Auto Response for reception of ARP REQ for Local Station. 0b: Disable 1b: Enable

30.4.3.36 Auto Response Configuration register2 (CSFR31)

Bit	31	30	29	28	27	26	25	24	23	22	21	20	19	18	17	16
	na_tc[7:0]								—	—	—	—	na_fl[19:16]			
Initial Value	0	0	0	0	0	0	0	0	0	0	0	0	0	0	0	1
R/W	R/W	R/W	R/W	R/W	R/W	R/W	R/W	R/W	R	R	R	R	R/W	R/W	R/W	R/W
Bit	15	14	13	12	11	10	9	8	7	6	5	4	3	2	1	0
	na_fl[15:0]															
Initial Value	1	1	1	1	1	0	1	1	0	1	1	1	0	1	0	1
R/W	R/W	R/W	R/W	R/W	R/W	R/W	R/W	R/W	R/W	R/W	R/W	R/W	R/W	R/W	R/W	R/W

Bit	Bit Name	Initial Value	R/W	Description
31 to 24	na_tc	H'00	R/W	Neighbor Advertisement Traffic Class Traffic Class of Auto Response Neighbor Advertisements for Received Neighbor Solicitations for Local Station. Write to this field when CSFR00.reply_fifo_en is "0".
23 to 20	—	All 0	R	Reserved When read, the initial value is read. When writing, be sure to write the initial value. Operation is not guaranteed if a value other than the initial value is written.
19 to 0	na_fl	H'00000	R/W	Neighbor Advertisement Flow Label Flow Label of Auto Response Neighbor Advertisements for Received Neighbor Solicitations for Local Station. Write to this field when CSFR00.reply_fifo_en is "0".

30.4.3.37 ARPREQ/Neighbor Solicitations Receive Interrupt Status register (CSFR40)

Bit	31	30	29	28	27	26	25	24	23	22	21	20	19	18	17	16
	—	—	—	—	—	—	—	—	—	—	—	—	—	—	—	—
Initial Value	0	0	0	0	0	0	0	0	0	0	0	0	0	0	0	0
R/W	R	R	R	R	R	R	R	R	R	R	R	R	R	R	R	R
Bit	15	14	13	12	11	10	9	8	7	6	5	4	3	2	1	0
	—	—	—	—	—	—	—	—	—	—	—	—	—	reply_fif o_full	reg_fifo _full	arp_ns
Initial Value	0	0	0	0	0	0	0	0	0	0	0	0	0	0	0	0
R/W	R	R	R	R	R	R	R	R	R	R	R	R	R	R/W	R/W	R/W

Bit	Bit Name	Initial Value	R/W	Description
31 to 3	—	All 0	R	Reserved Whenever it is read, 0 is read. The written value will be ignored.
2	reply_fifo_full	0b	R/W	Reply FIFO full This bit indicates that although TOE received ARPREQ or Neighbor Solicitations, but it was discarded because REPLY_FIFO is full. '1' Write: Clear '0' Write: Invalid
1	reg_fifo_full	0b	R/W	Reg FIFO full This bit indicates that although TOE received ARPREQ or Neighbor Solicitations, but it was discarded because REG_FIFO is full. '1' Write: Clear '0' Write: Invalid
0	arp_ns	0b	R/W	ARP Neighbor Solicitation This bit indicates that TOE received ARPREQ or Neighbor Solicitations and they are stored to REG_FIFO completely. '1' Write: Clear '0' Write: Invalid

30.4.3.38 ARPREQ/Neighbor Solicitations Receive Interrupt Mask register (CSFR41)

Bit	31	30	29	28	27	26	25	24	23	22	21	20	19	18	17	16
	—	—	—	—	—	—	—	—	—	—	—	—	—	—	—	—
Initial Value	0	0	0	0	0	0	0	0	0	0	0	0	0	0	0	0
R/W	R	R	R	R	R	R	R	R	R	R	R	R	R	R	R	R
Bit	15	14	13	12	11	10	9	8	7	6	5	4	3	2	1	0
	—	—	—	—	—	—	—	—	—	—	—	—	—	reply_fif o_full_m	reg_fifo _full_m	arp_ns_ m
Initial Value	0	0	0	0	0	0	0	0	0	0	0	0	0	0	0	0
R/W	R	R	R	R	R	R	R	R	R	R	R	R	R	R/W	R/W	R/W

Bit	Bit Name	Initial Value	R/W	Description
31 to 3	—	All 0	R	Reserved Whenever it is read, 0 is read. The written value will be ignored.
2	reply_fifo_full_m	0b	R/W	Reply FIFO full Mask Mask Configuration for ARPREQ/Neighbor Solicitations Receive Interrupt which occurs by reply_fifo_full. 0b: Non-Mask (Interrupt is asserted) 1b: Mask (Interrupt is not asserted)
1	reg_fifo_full_m	0b	R/W	Reg FIFO full Mask Mask Configuration for ARPREQ/Neighbor Solicitations Receive Interrupt which occurs by reg_fifo_full. 0b: Non-Mask (Interrupt is asserted) 1b: Mask (Interrupt is not asserted)
0	arp_ns_m	0b	R/W	ARP Neighbor Solicitation Mask Mask Configuration for ARPREQ/Neighbor Solicitations Receive Interrupt which occurs by arp_ns. 0b: Non-Mask (Interrupt is asserted) 1b: Mask (Interrupt is not asserted)

30.4.3.39 Rx ARPREQ/Neighbor Solicitation Upper MAC SA register (CSFR42_U)

Bit	31	30	29	28	27	26	25	24	23	22	21	20	19	18	17	16
	ns_option_type[7:0]								—	—	—	—	—	—	arp_ns_spec	rx_arp_ns
Initial Value	0	0	0	0	0	0	0	0	0	0	0	0	0	0	0	0
R/W	R	R	R	R	R	R	R	R	R	R	R	R	R	R	R	R
Bit	15	14	13	12	11	10	9	8	7	6	5	4	3	2	1	0
	arp_sa_mac[47:32]															
Initial Value	0	0	0	0	0	0	0	0	0	0	0	0	0	0	0	0
R/W	R	R	R	R	R	R	R	R	R	R	R	R	R	R	R	R

Bit	Bit Name	Initial Value	R/W	Description
31 to 5	ns_option_type	H'00	R	Neighbor Solicitations option type This field indicates Received Neighbor Solicitations Option Type. “H'00” means that Received Frame did not have Option. When rx_arp_ns = 0 (ARPREQ), this field is invalid.
23 to 18	—	All 0	R	Reserved Whenever it is read, 0 is read. The written value will be ignored.
17	arp_ns_spec	0b	R	ARP Neighbor Solicitations spec This field indicates Received ARPREQ/Neighbor Solicitations Frame Type. The Case of ARPREQ (rx_arp_ns = 0) 0b: ARPREQ 1b: GARPREQ The Case of Neighbor Solicitations (rx_arp_ns = 1) 0b: Multicast Neighbor Solicitations 1b: Unicast Neighbor Solicitations
16	rx_arp_ns	0b	R	ARP Neighbor Solicitations This field indicates which frame did TOE receive ARPREQ or Neighbor Solicitations. 0b: ARPREQ 1b: Neighbor Solicitations
15 to 0	arp_sa_mac	H'0000	R	ARP source Address MAC This field indicates the Source MAC Address [47:32] of Received ARPREQ/Neighbor Solicitation. When rx_arp_ns = 1 and ns_option_type = H'00, this field is invalid.

[Update timing of this register]

This register is updated when REG FIFO is empty and the interrupt of int_arp_ns_n caused by “Reception of ARPREQ or Neighbor Solicitations and Stored to REG FIFO” is asserted.

This register is updated when REG FIFO is not empty and the interrupt of int_arp_ns_n caused by “Reception of ARPREQ or Neighbor Solicitations and Stored to REG FIFO” is cleared by CSFR40.arp_ns.

30.4.3.40 Rx ARPREQ/Neighbor Solicitation Lower MAC SA register (CSFR42_L)

Bit	31	30	29	28	27	26	25	24	23	22	21	20	19	18	17	16
	arp_sa_mac[31:16]															
Initial Value	0	0	0	0	0	0	0	0	0	0	0	0	0	0	0	0
R/W	R	R	R	R	R	R	R	R	R	R	R	R	R	R	R	R
Bit	15	14	13	12	11	10	9	8	7	6	5	4	3	2	1	0
	arp_sa_mac[15:0]															
Initial Value	0	0	0	0	0	0	0	0	0	0	0	0	0	0	0	0
R/W	R	R	R	R	R	R	R	R	R	R	R	R	R	R	R	R

Bit	Bit Name	Initial Value	R/W	Description
31 to 0	arp_sa_mac	H'0000_0000	R	ARP source Address MAC This field indicates the Source MAC Address [31:0] of Received ARPREQ/Neighbor Solicitation. When rx_arp_ns = 1 and ns_option_type = H'00, this field is invalid.

[Update timing of this register]

This register is updated when REG FIFO is empty and the interrupt of int_arp_ns_n caused by “Reception of ARPREQ or Neighbor Solicitations and Stored to REG FIFO” is asserted.

This register is updated when REG FIFO is not empty and the interrupt of int_arp_ns_n caused by “Reception of ARPREQ or Neighbor Solicitations and Stored to REG FIFO” is cleared by CSFR40.arp_ns.

30.4.3.41 Rx ARPREQ/Neighbor Solicitation IP SA register i (i = 0 to 3) (CSFR43_i)

Bit	31	30	29	28	27	26	25	24	23	22	21	20	19	18	17	16
	iarp_sa_ip[32*j+31:32*j+16]															
Initial Value	0	0	0	0	0	0	0	0	0	0	0	0	0	0	0	0
R/W	R	R	R	R	R	R	R	R	R	R	R	R	R	R	R	R
Bit	15	14	13	12	11	10	9	8	7	6	5	4	3	2	1	0
	arp_sa_ip[32*j+15:32*j+0]															
Initial Value	0	0	0	0	0	0	0	0	0	0	0	0	0	0	0	0
R/W	R	R	R	R	R	R	R	R	R	R	R	R/W	R	R	R	R/W

Bit	Bit Name	Initial Value	R/W	Description
-----	----------	---------------	-----	-------------

31 to 0	arp_sa_ip	All 0	R	ARP source Address IP This field indicates the Source IP Address[32*j+31:32*j] of Received ARPREQ/Neighbor Solicitations.
---------	-----------	-------	---	--

The relationship between 'i' and 'j' is the following.

i = 0 -> j = 3

i = 1 -> j = 2

i = 2 -> j = 1

i = 3 -> j = 0

When rx_arp_ns = 0 (ARPREQ), Only Lower 32bit (CSFR43_3) is valid.

[Update timing of this register]

This register is updated when REG FIFO is empty and the interrupt of int_arp_ns_n caused by "Reception of ARPREQ or Neighbor Solicitations and Stored to REG FIFO" is asserted.

This register is updated when REG FIFO is not empty and the interrupt of int_arp_ns_n caused by "Reception of ARPREQ or Neighbor Solicitations and Stored to REG FIFO" is cleared by CSFR40.arp_ns.

30.5 Operation

The Gigabit Ethernet Interface consists of the following functional units:

- **DMA transfer controller (DMAC):**
Handles DMA transfer between the data storage areas for reception and transmission in the URAM and the reception and transmission FIFO
- **TCP/IP Offload Engine (TOE):**
Calculates Checksum by hardware. And also filters Ethernet Frames and responds specific frames automatically.
- **MAC controller (E-MAC):**
Handles reception/transmission transfer from/to the RGMII or MII.

Using its direct memory access (DMA) function, the DMAC handles DMA transfer of frame data between the destinations for storing Ethernet frame data for transmission and reception in the URAM and the FIFO for reception and transmission. Data cannot be directly read from or written to the FIFO.

To handle DMA transfer, the DMAC requires information that includes the addresses for storage of data for transmission and received data. These data are referred to as descriptors. The DMAC reads data for transmission from the storage area for data to be transmitted according to the information in descriptors and writes received data to the storage area for received data accompanied by information in descriptors. The descriptors are placed in the URAM. Arranging multiple descriptors in descriptor lists allows the continuous reception or transmission of multiple Ethernet frames.

TOE calculates checksum of received frames from E-MAC. And then it outputted to DMAC. TOE also calculates checksum of transmission frames from DMAC. And then it outputted to E-MAC. When TOE received any frames from E-MAC, it analyzes them. By the configuration of registers, TOE filters received frames. If received frame does not correspond to the configured filter conditions by registers, it will be discarded. By using this analysis function, TOE is also able to respond to ARP Request and Neighbor Solicitation automatically.

The E-MAC supports a RGMII and MII, which provides an interface format for the externally connected PHY-LSI. The E-MAC transmits frames from TOE to the RGMII or MII. It also transmits frames from the RGMII or MII to TOE.

30.5.1 DMAC Operating Modes

Figure 30.2 illustrates the operating modes of the DMAC.

Transitions of DMAC operating mode are under the control of the items listed below.

- CPU operating mode (hardware reset)
- Configuration of the operating mode configuration bits (CCC.OPC) in the DMAC mode register

The operating mode can be confirmed by reading the operating mode status bits in the DMAC status register (CSR.OPS).

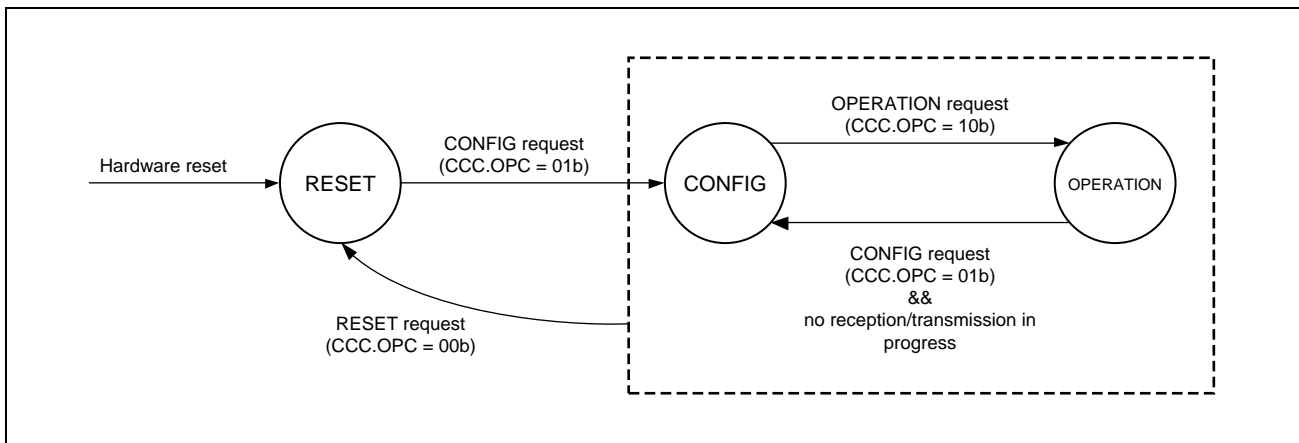

Figure 30.2 Operating Mode of DMAC

30.5.1.1 Operating Modes

(1) RESET mode

After a hardware reset, the DMAC enters RESET mode.

In RESET mode, only the DMAC operating mode control function is controllable and other functions are all stopped. This mode is designed for reduced power when the Ethernet function is not necessary.

(2) CONFIG mode

In CONFIG mode, various settings for the DMAC can be made.

The operation of most functions is stopped, and all status registers are initialized to their reset values.

(3) OPERATION mode

In OPERATION mode, all functions of the DMAC can operate. Ethernet communications can only proceed in this mode.

30.5.1.2 How to Set the Operating Mode

Set the operating mode configuration bits in the DMAC mode register (CCC.OPC) to select the operating mode. Furthermore, the operating mode can be checked by reading the operating mode status bits in the DMAC status register (CSR.OPS).

Transitions other than leaving from OPERATION mode are made after the value is written to the operating mode configuration bits (CCC.OPC).

For transitions leaving from OPERATION mode, it is not executed immediately because any transmission and reception in progress will be executed before leaving from OPERATION mode. To prevent any trouble, follow the “Stop Procedure” of **Section 30.5.13.4**.

30.5.1.3 Operating Mode Transitions Due to Hardware

The following hardware factors can also initiate transitions of the DMAC operating mode.

(1) Hardware reset

Resetting of the LSI chip leads to resetting of the entire Gigabit Ethernet Interface. The operating mode shifts to RESET mode.

30.5.2 Descriptors

30.5.2.1 Data Representation in URAM

The DMAC transfers data for transmission and received data to and from the application software via the URAM.

The memory in the URAM for use by the DMAC is configured with control structures referred to as descriptors and associated areas to which the frame data are allocated. Dividing the memory into a control area and data area allows the flexible allocation of frame data to the URAM. This enables sharing of the areas to which frame data are allocated and the use of non-contiguous areas. Frame data can be copied without using the CPU. Arbitration that ensures hardware and software access to the memory area is also available without access to registers of the DMAC.

Figure 30.3 shows an example of the memory maps for descriptors and the descriptor data area in the URAM.

A descriptor consists of its type (DESCR.DT), which controls the descriptor functions, a descriptor pointer (DESCR.DPTR) indicating the start address for storage of the frame data in the descriptor area, and the data size field (DESCR.DS), indicating the amount of frame data. Post-processing interrupt generation can be set up for each descriptor. Enabling and disabling of the interrupt is controlled by the descriptor processed interrupt enable bits (DESCR.DIE).

The descriptor may also hold information related to content. This information does not affect general descriptor functions. It provides information other than the frame data proper, such as on the state of reception.

For details, see **Section 30.5.3.2, Setting Up Reception Descriptors**, and **Section 30.5.4.1, Setting Up Transmission Descriptors**.

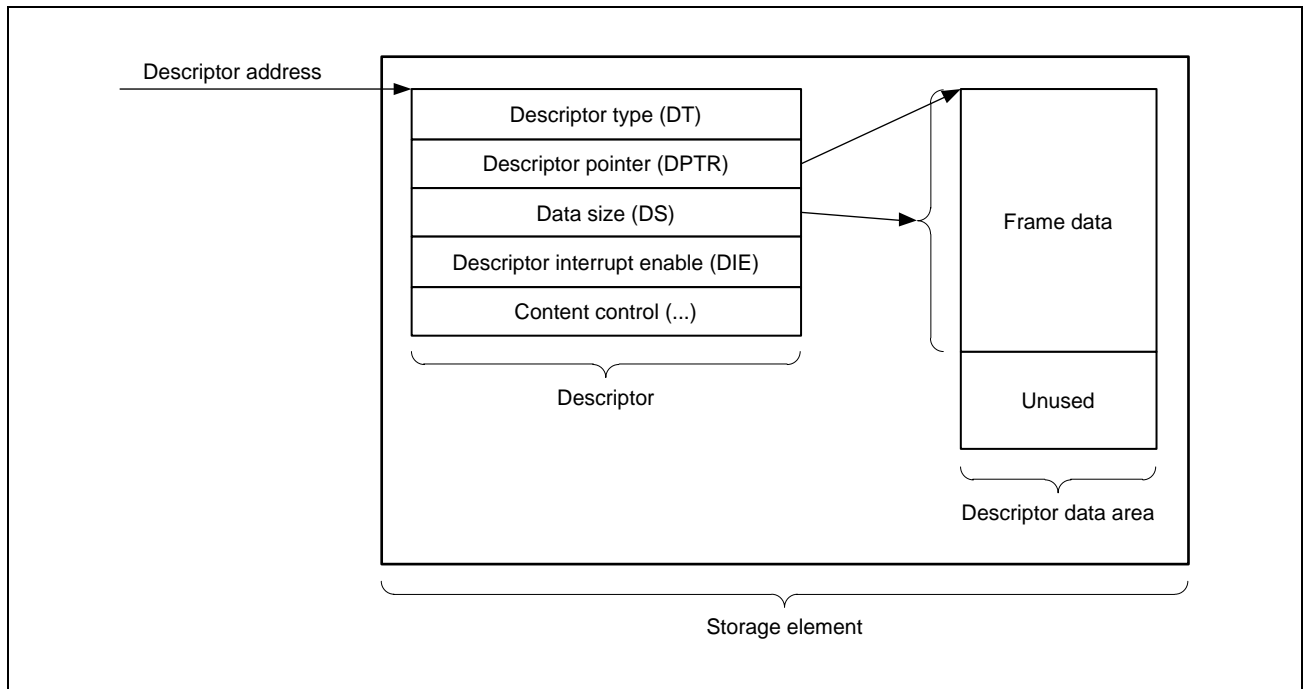

Figure 30.3 Outline of Storage Element Used for Receive and Transmit Queues

The descriptor must be aligned with a 32-bit boundary in the URAM.

Descriptors are configured of 64 bits.

The frame data must also be aligned with a 32-bit boundary in the URAM.

The amount of data in the frame is defined by the data size bits (DESCR.DS). In reception, these bits indicate the upper limit on the size of frames to be received. If the data size is not aligned with a 32-bit boundary, the bytes to the next 32-bit boundary in the data area will be an unused area.

30.5.2.2 Using Descriptor Chains in Queues

Transmission and reception descriptors in the URAM are grouped into queues. The queue is capable of controlling one or more frames. Accordingly, multiple descriptors can be assigned to one queue. A combination of multiple descriptors is referred to as a descriptor chain.

For a descriptor chain, the three general descriptor types listed below are defined. For details on these descriptor types, see **Section 30.5.2.6, Descriptor Type**.

- Descriptors that define frame data
- Descriptors that control the descriptor chain itself (e.g. LINK, EOS).
- Descriptors that arbitrate access by hardware or software

Figure 30.4 shows the two basic topologies for descriptor chains. In the simplified examples in the figure, all descriptors allocated to the chain are stored in the array.

- For a linear descriptor chain, the last descriptor in the array is a control descriptor indicating the end of the descriptors (e.g. EEMPTY).

- For a cyclic descriptor chain, the last descriptor in the array is a control descriptor that returns to the first descriptor in the array (e.g. LINK).

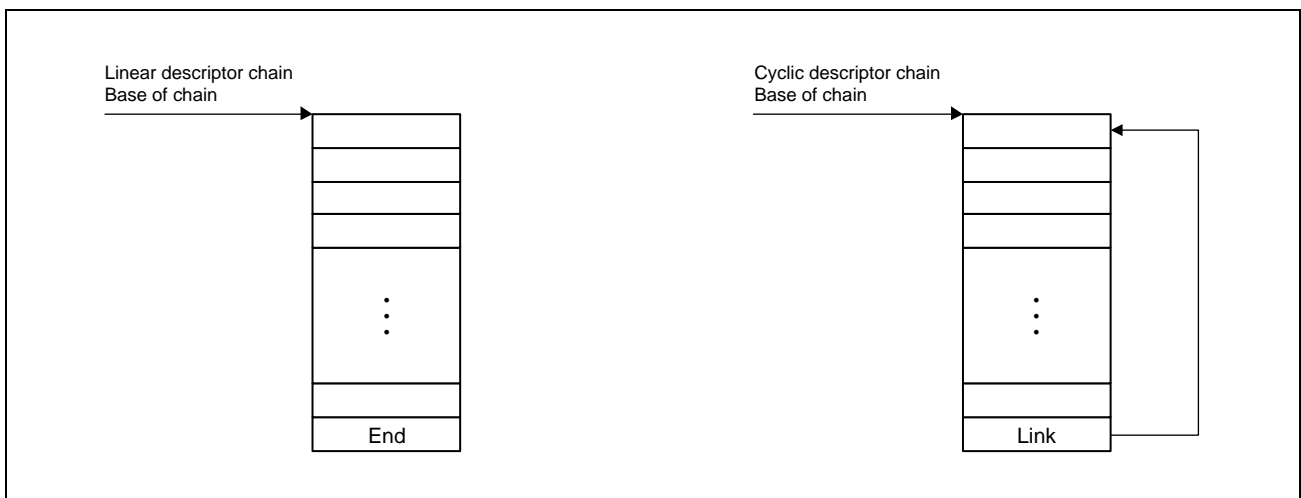

Figure 30.4 Outline of the Basic Descriptor Chains

The relationship between queue and descriptor chain is defined by the base addresses of chain. A queue is connected to one descriptor chain over one round of processing. There is also a method of switching to a different chain while in OPERATION mode.

There are no restrictions on the number of link descriptors and their locations within the chain. The last descriptor of a designed chain determines the topology.

Which chain structure should be used or which topology is suitable depend on the application. A description of how to design descriptor chains to suit various applications is given in **Section 30.5.3.2, Setting Up Reception Descriptors**, and **Section 30.5.4.1, Setting Up Transmission Descriptors**.

30.5.2.3 Descriptor Base Address Table

The base address table in the URAM contains the address of the first descriptor of all chains to be handled by the respective queues.

Entry 0 is used to access transmission queues. Entry 4 is used to access reception queue.

The configuration of entries in the base address table is the same as the configuration of link descriptors. We recommend using the descriptor type (DESCR.DT) LINKFIX. Processing of this link descriptor does not change it, so it does not require updating. The first descriptor of a chain performs hardware and software synchronization. If the application requires hardware and software synchronization for the base addresses, use the descriptor type (DESCR.DT) LINK.

The CPU is only capable of using LINKFIX and LINK as descriptor types (DESCR.DT) of descriptors in the base address table.

Set the location of the base address table in the URAM in the descriptor base address table register (DBAT).

Figure 30.5 shows an example of a base address table for controlling transmission and reception queues. The boxes to the right of the table represent descriptor chains with the desired topologies.

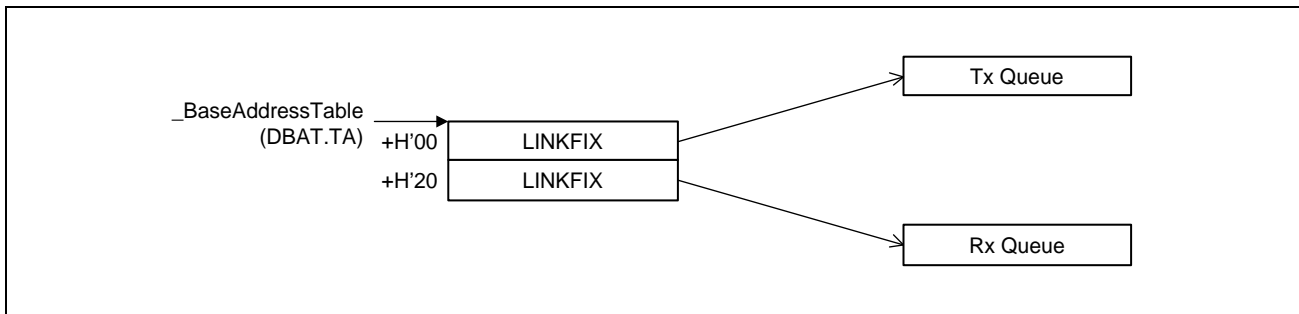

Figure 30.5 Example of a Base Address Table for Reception and Transmission Queues

30.5.2.4 Descriptor Chain Processing

The descriptor that is currently processed or will be processed when the related queue gets active is the current descriptor. The current descriptor address for use by a queue q can be checked in the current descriptor address register q (CDAR q).

Current descriptors are stored in registers or in descriptors as described below in the given situations.

- In the descriptor base address table registers for all q queues (DBAT) (DBAT.TA+8* q) when the operating mode shifts to OPERATION mode.
- In the descriptor base address table register (DBAT) (DBAT.TA+8* q) when a base address load request is issued for a queue q by setting the corresponding bit (DLR.LBA q) in the descriptor base address load request register (DLR).
- In DESC.RDPTR for a link descriptor (LINK, LINKFIX) to be processed.
- After a descriptor has been processed, the current descriptor for the same queue is incremented by the size of the descriptors being handled by the queue. The DMAC updates the descriptor type and informs the CPU that the descriptor has been processed.

30.5.2.5 Descriptor Interrupts

A descriptor is able to issue a descriptor interrupt on completion of its processing. The setting of the descriptor interrupt enables bits (DESCR.DIE) in each descriptor selects disabling or generation of the descriptor interrupt.

The descriptor interrupt is a common resource that is shared between reception and transmission queues. Software control of the descriptor interrupt provides a flexible method of application-specific flag processing.

Figure 30.6 illustrates the way in which the DMAC generates descriptor interrupts (or sets bits in the descriptor interrupt status register (DIS.DPFI)). Processing of a descriptor with the value i in the descriptor interrupt enable bits (DESCR.DIE) leads to the corresponding bit in the descriptor interrupt status register (DIS.DPFI) being set.

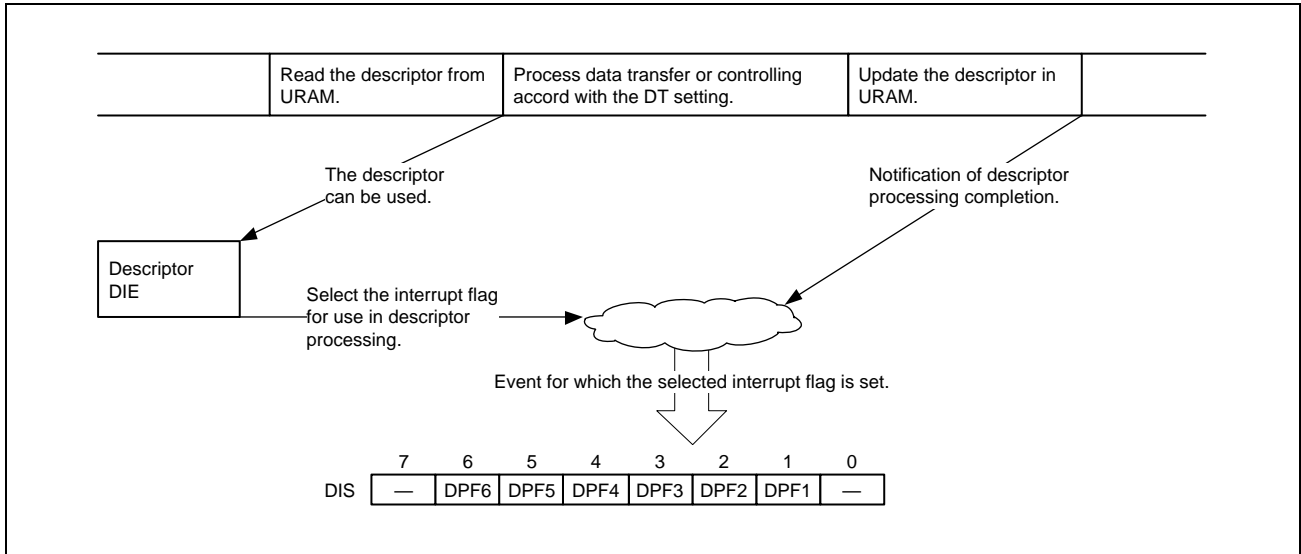

Figure 30.6 Method of Descriptor Interrupt Generation

30.5.2.6 Descriptor Type

The descriptor types (indicated by the `DESCR.DT` bits) supported by the DMAC fall into the following three categories.

- Definitions of frame data
- Control of descriptor chains
- Hardware and software arbitration

Table 30.7 is a summary of the descriptor types available for the DMAC. Entries under “Name” are the names of the descriptor types and the values under “DT” are the corresponding values to be set in the descriptor type field (`DESCR.DT`). A given descriptor may be handled differently according to whether it is in a transmission or reception queue, so the transmission and reception columns list the scopes of control and processing of the descriptor types.

The abbreviations defined below are used in the transmission and reception columns.

Definition of SW:

- The descriptor is processed by software.
- Software has access to and may modify the descriptor and descriptor data area.
- This descriptor cannot be changed by hardware (DMAC).

Definition of HW:

- The descriptor is processed by hardware (DMAC).
- Software must modify neither the descriptor nor the descriptor data area.
- Hardware (DMAC) processes this descriptor and subsequently changes the descriptor type.

Invalid:

- This descriptor type is not used in transfer in the given direction (transmission or reception).
- Do not write to this value to the descriptor type (`DESCR.DT`) field for transfer in the given direction.

- Hardware does not process these descriptor types in the cases listed as invalid. The current descriptor address (CDARq.CDA) will not be changed when processing of a queue for the given direction arrives at a descriptor with this type setting.

Table 30.7 Summary of Descriptor Types

Name	DT	Description	Reception	Transmission
Frame data				
FSTART	5	Frame Start The descriptor points to valid data for a frame. The frame starts with the given data and continues with that indicated by the next descriptor.	SW	HW
FMID	4	Frame Middle The descriptor points to valid data for a frame. The frame started with a previous descriptor and continues to the data indicated by the next descriptor.	SW	HW
FEND	6	Frame End The descriptor points to valid data for a frame. The frame continues from the previous descriptor and ends with the data indicated by in this descriptor.	SW	HW
FSINGLE	7	Frame Single The descriptor points to valid data for a complete frame.	SW	HW
Chain control				
LINK	8	Link Defines the next descriptor in the chain.	HW	HW
LINKFIX	9	Fixed Link Same as LINK, but not changed by DMAC after processing.	SW	SW
EOS	10	End Of Set Control element to split a descriptor chain. The chain stops and waits for user interaction.	HW	HW
HW/SW arbitration				
FEMPTY	12	Frame Empty A descriptor related to frame data but not containing valid data for a frame	HW	SW
DT13	13	Reserved	Invalid	Invalid
DT14	14	Reserved	Invalid	Invalid
FEMPTY_ND	15	Frame Empty No Data storage A descriptor related to frame data but not containing valid data for a frame. The descriptor is processed in the same way as FEMPTY, but data are not stored in the URAM.	HW	Invalid
LEEMPTY	2	Link Empty A link descriptor for processing by the DMAC	SW	SW
EEMPTY	3	EOS Empty An EOS descriptor for processing by the DMAC	SW	SW
DT0	0	Reserved	Invalid	Invalid
DT1	1	Reserved	Invalid	Invalid
DT11	11	Reserved	Invalid	Invalid

30.5.2.7 Layout of General Descriptors in the URAM

The DMAC updates processed descriptors in the URAM. The field to be changed in the descriptor being updated depends upon whether the direction is transmission or reception and the queue mode. Other fields will not be changed. There are no restrictions on the values set in unused descriptor fields (indicated by “—” in the figure).

(1) Frame Data Descriptors

The allocation of bits in the frame data descriptors (FSTART, FMID, FEND, and FSINGLE) is shown below.
usable in both reception and transmission

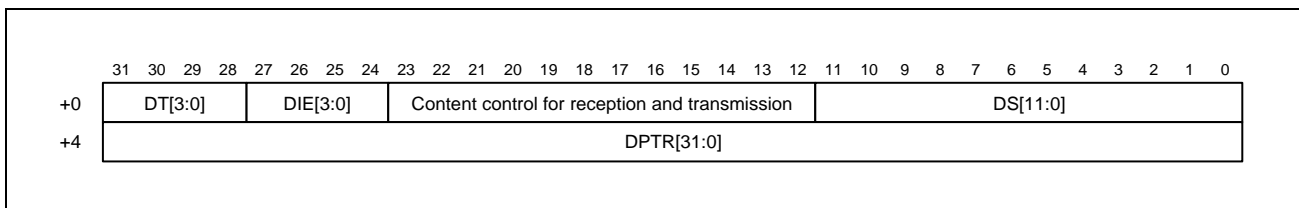

Figure 30.7 The allocation of bits in the frame data descriptors

Table 30.8 Contents of Frame Data Descriptors (DESCR)

Bit Name	Function
DT[3:0]	Descriptor Type 5: FSTART 4: FMID 6: FEND 7: FSINGLE For details, see Section 30.5.3.2, Setting Up Reception Descriptors , and Section 30.5.4.1, Setting Up Transmission Descriptors .
DIE[3:0]	Descriptor Interrupt Enable 0000b: Descriptor interrupt is disabled. 0001b to 1111b: The corresponding descriptor interrupt is generated (DIS.DPFI).
—	Content Control For details, see Section 30.5.3.2, Setting Up Reception Descriptors , and Section 30.5.4.1, Setting Up Transmission Descriptors .
DS[11:0]	Data Size Size of the data area/frame data for the descriptor (in bytes)
DPTR[31:0]	Descriptor Pointer Pointer to the data area for the descriptor

Note: Register an address aligned with a 32-bit boundary as the descriptor pointer (DESCR.DPTR).

(2) Hardware/Software Arbitration Descriptors (Only for Reception)

The allocation of bits in the descriptors for hardware/software arbitration (FEMPTY and FEMPTY_ND) is shown below.

The allocation of bits in the arbitration descriptors for use in reception is the same as in frame data descriptors.

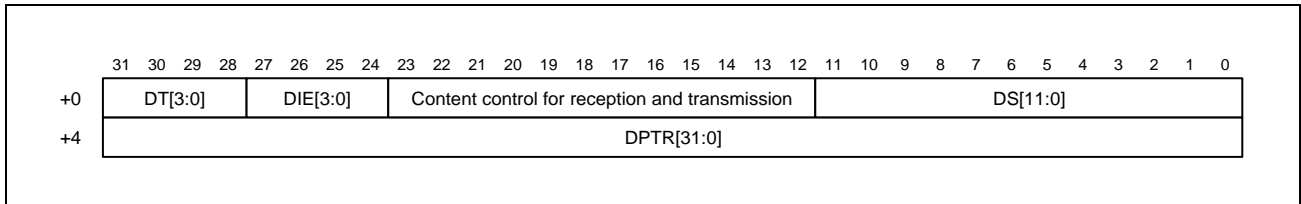

Figure 30.8 The allocation of bits in the arbitration descriptors

Table 30.9 Contents of Hardware/Software Arbitration Descriptors (DESCR)

Bit Name	Function
DT[3:0]	Descriptor Type 12: FEMPTY 15: FEMPTY_ND For details, see Table 30.7, Summary of Descriptor Types.
DIE[3:0]	Descriptor Interrupt Enable 0000b: Descriptor interrupt is disabled. 0001b to 1111b: The corresponding descriptor interrupt is generated (DIS.DPFI).
—	Content Control For details, see Section 30.5.3.2, Setting Up Reception Descriptors , and Section 30.5.4.1, Setting Up Transmission Descriptors.
DS[11:0]	Data Size Size of the data area/frame data for the descriptor (in bytes)
DPTR[31:0]	Descriptor Pointer Pointer to the data area for the descriptor

Note: Register an address aligned with a 32-bit boundary as the descriptor pointer (DESCR.DPTR).

In an FEMPTY descriptor, the descriptor type (DT), descriptor interrupt enable (DIE), data size (DS), and descriptor pointer (DPTR) fields are used.

In an FEMPTY_ND descriptor, the descriptor type (DT), descriptor interrupt enable (DIE), and data size (DS) are used.

(3) Link Descriptors

The allocation of bits in the link descriptors (LINK and LINKFIX) is shown below.

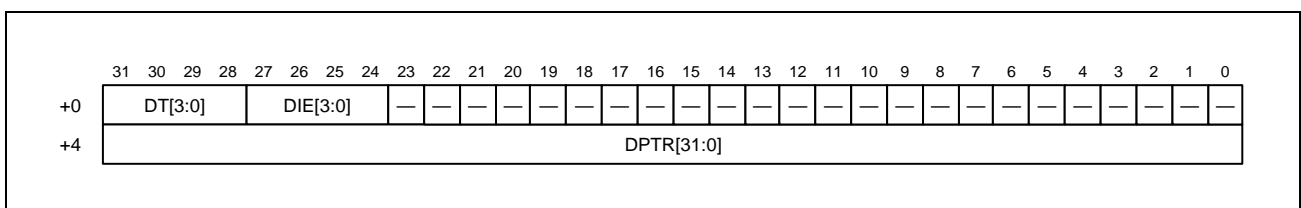

Figure 30.9 The allocation of bits in the link descriptors

Table 30.10 Contents of Link Descriptors (DESCR)

Bit Name	Function
DT[3:0]	Descriptor Type 8: LINK 9: LINKFIX For details, see Table 30.7, Summary of Descriptor Types.
DIE[3:0]	Descriptor Interrupt Enable 0000b: Descriptor interrupt is disabled. 0001b to 1111b: The corresponding descriptor interrupt is generated (DIS.DPFI).
DPTR[31:0]	Descriptor Pointer Pointer to the data area for the descriptor Register an address on a 32-bit boundary.

Note: Register an address aligned with a 32-bit boundary as the descriptor pointer (DESCR.DPTR).

(4) Other Descriptors

The allocation of bits in the other descriptors (EOS, FEMPTY (only for transmission), LEMPTY, and EEMPTY) is shown below.

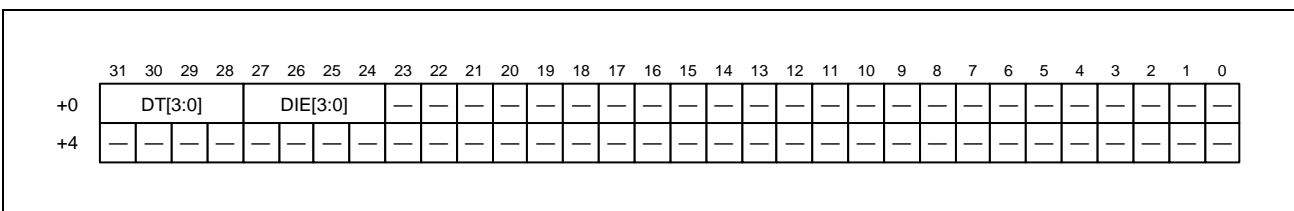

Figure 30.10 The allocation of bits in the other descriptors

Table 30.11 Contents of Other Descriptors (DESCR)

Bit Name	Function
DT[3:0]	Descriptor Type 10: EOS 12: FEMPTY (only for transmission) 2: LEMPTY 3: EEMPTY For details, see Table 30.7, Summary of Descriptor Types.
DIE[3:0]	Descriptor Interrupt Enable 0000b: Descriptor interrupt is disabled. 0001b to 1111b: The corresponding descriptor interrupt is generated (DIS.DPFI).

30.5.2.8 How to Use Frame Data Descriptors

In general, Ethernet frames are not of uniform length. The DMAC is capable of dividing frame data into multiple descriptors in order to minimize the memory capacity for frame data. This function allows processing of frames that are longer than the limit for descriptor data areas. Division can also be applied to frames on the basis of their data structures.

To handle frames and descriptors, four descriptor types (DESCR.DT) as FSTART, FEND, FMID and FSINGLE are defined.

Figure 30.11 shows the mapping of frame data by frame data descriptors. The descriptor data areas are allocated to the URAM. For frames that require division into four or more data areas, additional FMID descriptors can be added as required.

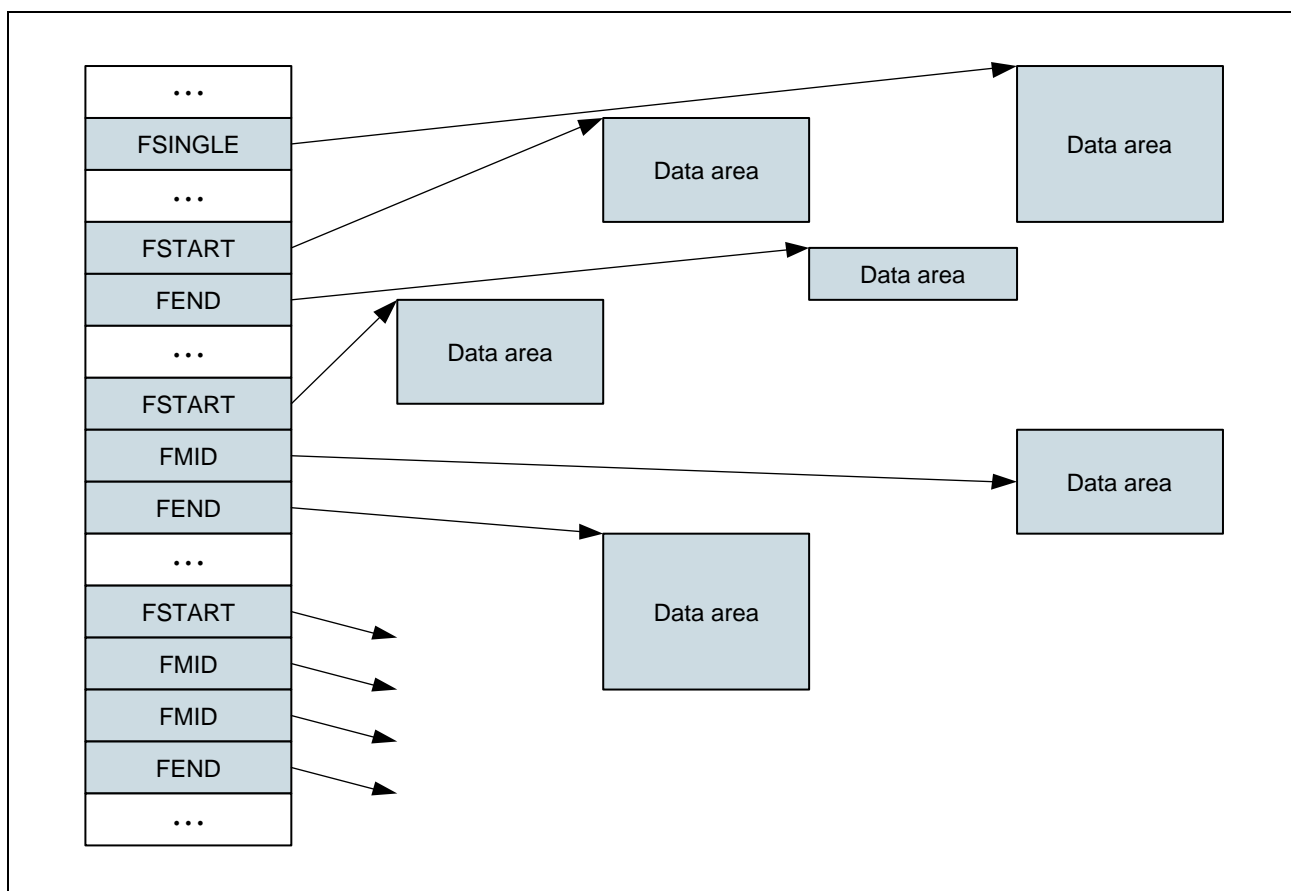

Figure 30.11 Mapping of Frame Data

For reception, the DMAC will store received frame data in the given area. If a received frame has more data than the descriptor data size (DESCR.DS), the DMAC will divide the data up.

For transmission, set the descriptor data size (DESCR.DS) to the actual data size. The DMAC modifies the descriptor type (DESCR.DT) to FEMPTY after processing the relevant descriptor. The data size (DESCR.DS) and descriptor pointer (DESCR.PTR) fields retain their settings.

30.5.2.9 How to Use Chain Control Descriptors

(1) Link Descriptors

The link descriptors can be used to set up cyclic descriptor chains (for details, see **Section 30.5.2.2, Using Descriptor Chains in Queues**)

After a LINK descriptor is processed, its descriptor type (DESCR.DT) is changed to LEMPT. The descriptor pointer (DESCR.PTR) retains its setting.

After processing of a LINKFIX descriptor, the descriptor type (DESCR.DT) is not updated. Software can change the descriptor type (DESCR.DT), descriptor interrupt enable (DESCR.DIE), and descriptor pointer (DESCR.DPTR). However, DESCR.DT should not be modified by software. Take care to check the current descriptor address register (CDARq.CDA) before changing the descriptor pointer (DESCR.DPTR).

(2) EOS Descriptor

Use the EOS descriptor to divide a descriptor chain into various segments. The queue can continue even after an EOS descriptor.

In transmission, the response to an EOS descriptor is clearing of the transmit start request bit in the transmit configuration control register (TCCR.TSRQ) to 0.

In reception, the response is generation of a receive queue full interrupt (RIS2.QFF), although if the frame currently being received is being divided for storage (received data such as those where some storage is in FMID- or FEND-type frames), the data are not completely stored.

30.5.2.10 How to Use Hardware and Software Arbitration Descriptors

In hardware processing of descriptors, the empty descriptor types (FEMPT, LEMPT, and EEMPT) are used to distinguish various descriptors. For software, they can be used to initiate checking for empty spaces, etc.

(1) FEMPT and FEMPT_ND

These descriptor types (DESCR.DT) are used for descriptors that do not contain effective data. Of these, only FEMPT is used in transmission. The descriptor pointer of a FEMPTxxx descriptor refers to a descriptor data area.

(2) LEMPT

This descriptor type (DESCR.DT) is assigned to LINK descriptors after they have been processed. The descriptor pointer (DESCR.DPTR) of an LEMPT descriptor still points to the linked descriptor.

(3) EEMPT

This descriptor type (DESCR.DT) is assigned to EOS descriptors after they have been processed. The descriptor pointer (DESCR.DPTR) of an EEMPT descriptor is not used.

30.5.2.11 Synchronization between Descriptor Access by Hardware and Software

The allocation of descriptor types (DESCR.DT) to the URAM can be used to set up the primary synchronization between hardware and software. By this, the number of CPU accesses to registers of Gigabit Ethernet Interface can be minimized and performance can be increased.

Basic concepts of synchronization:

- Each descriptor type in the set is exclusively for processing by hardware or software, depending on the direction of transfer (see **Table 30.7, Summary of Descriptor Types**).
- Software must not change a descriptor assigned to hardware processing (the hardware does not change descriptors assigned to software processing).

In the case of software processing, the software must process the information in the descriptor and the corresponding frame data before changing the descriptor type. If a descriptor type for hardware is set in DESCR.DT, the software should not change any part of the descriptor or of the corresponding frame data.

30.5.2.12 Tips for Optimizing Performance in Handling Descriptors

The following items are recommended as ways to ensure the optimal use of data structures in the URAM.

They are not requirements but using a different approach may increase the load on the system bus within the LSI chip.

- Register descriptors with 64-bit alignment.
- While in OPERATION mode, use LINKFIX instead of LINK whenever a descriptor need not be changed. Hardware modifies the descriptor type (DESCR.DT) fields of LINK descriptors.
- Frame data is accessed in blocks up to 128 bytes.
- The number of 128 byte borders (addresses H'xxx00 and H'xxx80) and frame data inside should be minimized.
- Design the descriptor chains in ways that minimize parallelism of processing. This helps in dividing the chains into segments allocated to different cache pages, and in arranging the different segments exclusively for access by software or hardware.
- Minimize the number of divided frames. This can reduce the overhead of descriptor handling.

30.5.3 Reception Control

The point of the DMAC is to transfer data between the TOE/E-MAC and URAM without intervention by the CPU.

DMAC needs descriptors that define the amounts of frame data to be stored and the locations. When the E-MAC received a frame, it is transferred to TOE and the conditions of reception is also transferred to DMAC as the E-MAC state. The checksum of received frame is calculated by TOE, the received frame is stored to Reception FIFO temporary. If TOE detects any errors from received frame (such as it was unsupported frame or checksum error), the error information is notified to DMAC. After that, the received frame is transferred to URAM by DMAC. At the time, MAC-Status and Error Information of TOE are written to Reception Descriptor by Write Back. For a description of how to set up descriptors for use in reception, see **Section 30.5.3.2, Setting Up Reception Descriptors**.

Figure 30.12 shows the reception data bus.

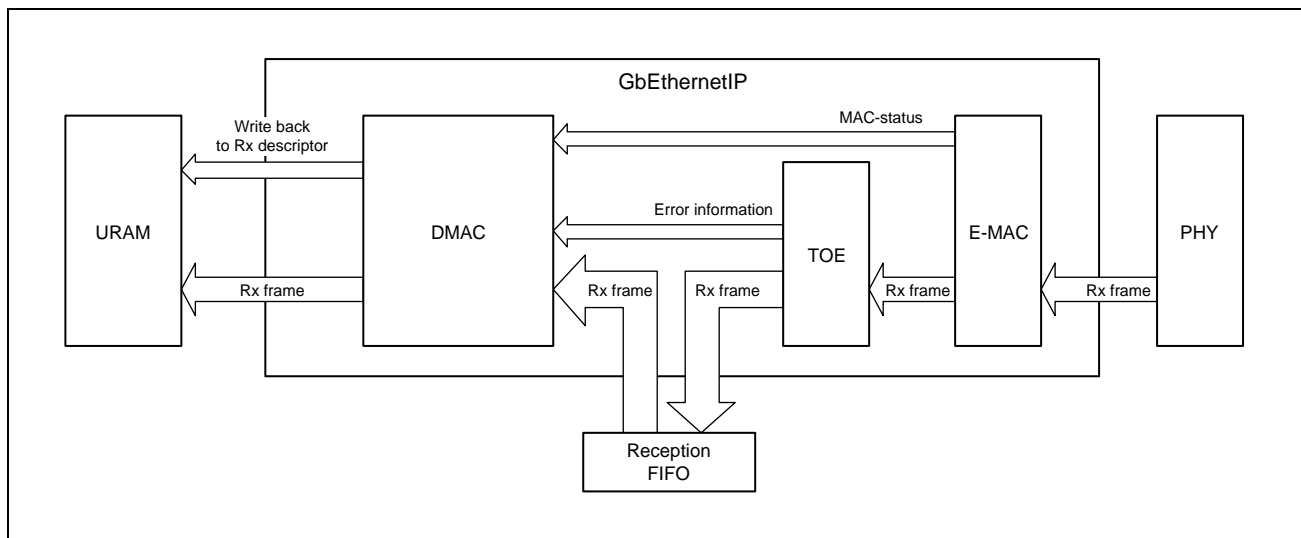

Figure 30.12 Mechanism of General Reception

30.5.3.1 Reception Queues

The DMAC stores all received frames in the URAM.

There is a condition for the DMAC to discard a received frame.

- Detection of an error during reception by the TOE and E-MAC
 - Whether error frames are discarded or stored in reception queue depends on the setting of the error frame enable bit in the receive configuration register (RCR.EFFS). If error frames are to be stored (RCR.EFFS = 1*1), they are always stored in queue. In this case, characteristics specific to the queue (e.g. truncation) will vary.

Note 1. RCR.EFFS = 1 is only for debug. Do not set this condition during normal operation.

The flowchart in **Figure 30.13** shows how the DMAC selects the reception queue in accord with the frame type. The result is storage of the frame in the proper queue or the frame being discarded.

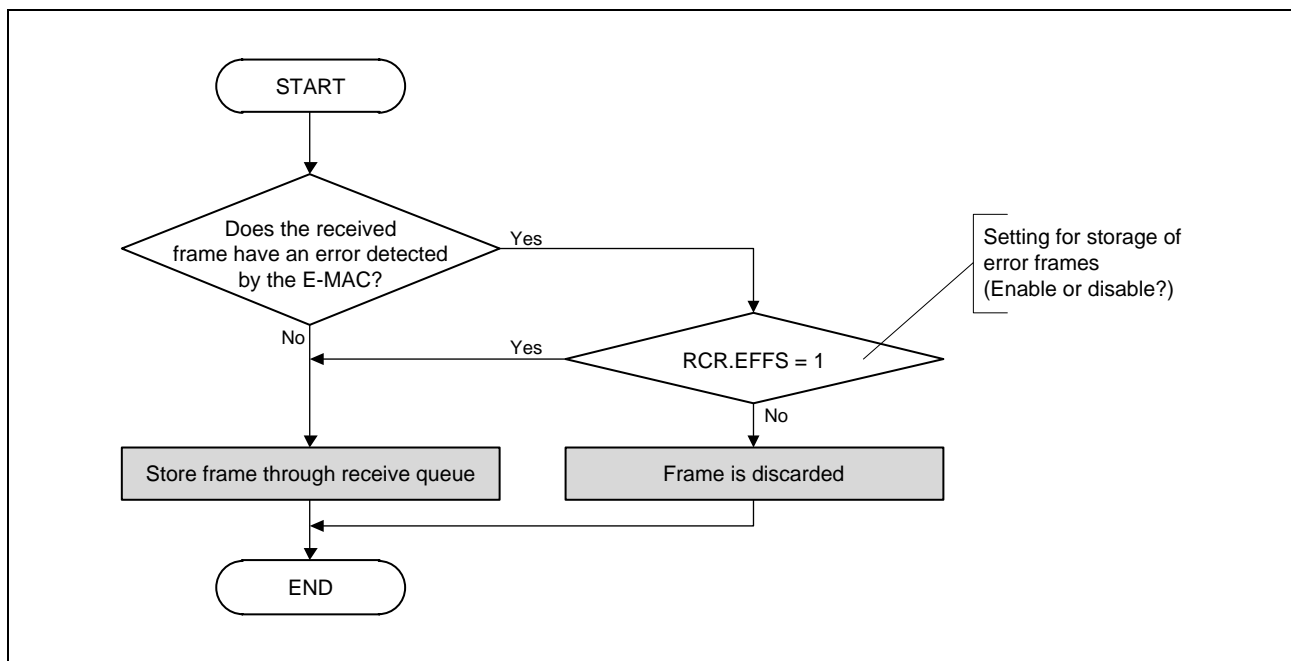

Figure 30.13 Mechanism of Reception Queue Selection

30.5.3.2 Setting Up Reception Descriptors

For reception, the descriptor mechanism is essentially as described in **Section 30.5.2, Descriptors**.

This section describes memory operations that are especially required in handling reception queues.

(1) Reception Descriptor Type

The type of a descriptor is defined by the descriptor type (DESCR.DT) field.

Table 30.12 shows the descriptor types used in reception.

Table 30.12 Descriptor Types in Reception

Descriptor Type (DESCR.DT)	Operation	Write-back
Frame Start (FSTART)	Condition for data not being stored in a reception queue: The RIS2.QFF bit indicates that queue r is full, and the received frame is not stored. Descriptor processing proceeds again in response to further reception.	Not changed
Frame Middle (FMID)	Same as FSTART	Not changed
Frame End (FEND)	Same as FSTART	Not changed
Frame Single (FSINGLE)	Same as FSTART	Not changed
Link (LINK)	Processing proceeds to the descriptor specified by DESCR.DPTR.	LEMPY
Fixed Link (LINKFIX)	Same as LINK	Not changed
End Of Set (EOS)	A stop point defined by software has been reached. A descriptor of this type within a divided frame (writing of FMID or FEND) stops the frame being stored and the frame is lost. RIS2.QFF indicates that the frame has been lost. If this happens at the start of a frame (writing of FSTART or FSINGLE), storing of frames starts from the next descriptor. In either case, processing shifts to the next descriptor in the chain.	EEMPTY
Frame Empty (FEMPTY)	The descriptor can be used to store received data. Up to DESCR.DS bytes are stored in the descriptor data area. For details, see Section 30.5.3.3(1), Storing Frame Data in the Descriptor Data Area .	FSTART, FMID, FEND, or FSINGLE
Frame Empty No Data storage (FEMPTY_ND)	The descriptor can be used to store received data. Up to DESCR.DS bytes are captured from the Reception FIFO but not stored. After processing, DESCR.DS is written back as 0.	FSTART, FMID, FEND or FSINGLE
Link Empty (LEMPY)	Same as FSTART	Not changed
EOS Empty (EEMPTY)	Same as FSTART	Not changed

(2) Configuration of Reception Frame Data Descriptors

Figure 30.14 shows the configuration of descriptors for use with reception queues. The reception-specific fields (DESCR.MSC, DESCR.PS, DESCR.EI, and DESCR.TI) are described in **Table 30.8**.

For the other fields and the descriptor types, see **Section 30.5.2.6, Descriptor Type**.

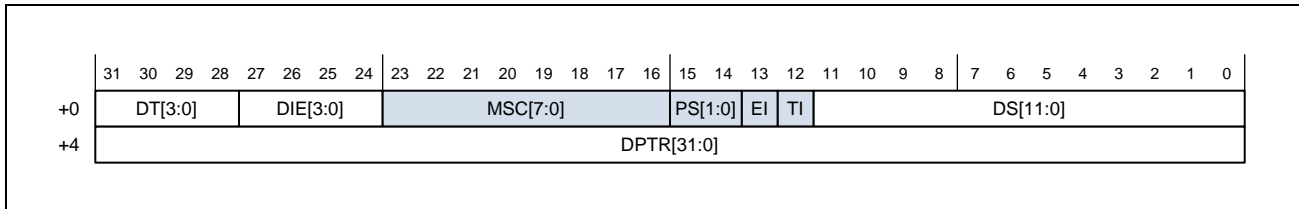

Figure 30.14 Configuration of Descriptor for a Received Frame

Table 30.13 Configuration of a Received Descriptor

Bit Name	Function
MSC	<p>E-MAC/TOE Status Code</p> <p>These bits indicate errors in reception detected by the E-MAC and TOE. In the case of a divided frame, the bits are set to the same value within all descriptors for the frame data. Details of the bits are as follows.</p> <p>MSC [7]: Received frame has a multicast address. (E-MAC)</p> <p>MSC [6]: Check-sum error (TOE)</p> <p>MSC [5]: Received Unsupported frame (TOE)</p> <p>MSC [4]: Received frame has alignment error. (E-MAC)</p> <p>MSC [3]: Received frame is too long. (E-MAC)</p> <p>MSC [2]: Received frame is too short (E-MAC)</p> <p>MSC [1]: Error in frame reception (E-MAC)</p> <p>MSC [0]: Received frame has a CRC error. (E-MAC)</p>
PS	<p>Padding Selection</p> <p>00b: Padding is not to be inserted.</p>
EI	<p>Error Indication</p> <p>This bit indicates the detection of an error in frame data while a frame was being stored. The bit is set to 1 for a descriptor in which an error has been detected. If the descriptor is for a divided frame, storage of the frame is aborted.</p> <p>0: No error</p> <p>1: Error is detected</p>
TI	<p>Truncation Indication</p> <p>This bit indicates whether frame data received from the E-MAC have been truncated before being stored. The bits are set to the same value within all frame data descriptors for a divided frame.</p> <p>0: Data have not been truncated.</p>

Note: The RCR.EFFS bit specifies whether frames with errors detected by the TOE or E-MAC are to be stored in the URAM or not. When the storing of error frames is disabled, error codes are not written to DESCR.MSC.

30.5.3.3 Reception Processing

After initialization, the DMAC can store received frames in the data area in the URAM as indicated by the descriptor. The DMAC continues to store received data in the URAM as long as space is available for descriptors and data areas.

If the Reception FIFO contains even one frame, storing is executed to the reception queue.

If there is even one empty data descriptor in a queue for which reception has started, the storage of frame data starts. Received frames for a queue that is already full (there is no empty frame descriptor) are discarded from the Reception FIFO.

(1) Storing Frame Data in the Descriptor Data Area

Frame data for storage are assumed to be in either of the two patterns described below.

- The data for an entire frame will fit in the descriptor data area.
 - In this case, the descriptor type (DESCR.DT) is FSINGLE.
- Frame data to be stored in the descriptor data area arrive in divided form.
 - In this case, FSTART is written to the descriptor type (DESCR.DT) bits of the first descriptor of the frame data to arrive and FMID and FEND are written to the type bits of descriptors for subsequent data.

The descriptor type is updated by the DMAC in the last step of descriptor processing, so software can always access the descriptor assigned to DESCR.DT.

The CPU can write FEMPTY (or FEMPTY_ND) directly to the descriptor type field after processing the stored element. Do not change the descriptor or any part of the descriptor data area after FEMPTY (or FEMPTY_ND) is written to DESCR.DT.

(1) Storing Frame Data for a Whole Single Frame

For a frame with an FSINGLE descriptor, all data for the frame are held at the position defined by DESCR.DPTR. DESCR.DS indicates the length of the received frame.

If DESCR.DS is bigger than the actual size of a received frame, the FSINGLE descriptor is stored in place of the FEMPTY or FEMPTY_ND descriptor after processing.

(2) Storing Frame Data as Divided Frames

Divided frames are handled in the same way as a single frame. A frame stored with divided descriptors must be recombined before use. DESCR.EI is only valid in the last descriptor of the sequence for a divided frame.

NOTE

If the data area size setting in DESCR.DS is not a multiple of four, the number of bytes set in DESCR.DS is fetched from the Reception FIFO and the remaining bytes are used as the next storage area.

After a received frame is divided into different descriptors, each storage element is handled separately, and the descriptor type is assigned by software after processing. Accordingly, an error frame (FEMPTYxxx instead of FMID or FEND) may exist while a descriptor chain is being processed. In such a case, the CPU must postpone processing of the error frame to the next trigger point.

(3) No Data are Stored

The application specification may lead to some types of received frames being unimportant (for example, when the application only requires stream data from the Ethernet frames). Storing frames in divided form makes separating out the unnecessary parts of Ethernet frames possible.

If part of a divided frame is not required, use the FEMPTY_ND descriptor for that part so that it is not stored in the URAM. Not storing the data negates the need for bandwidth on the data bus, improving the overall performance.

When an FEMPTY_ND descriptor is processed, DESCR.DS is set to 0. This brings the frame data section of the descriptor into agreement with the FEMPTY type. DESCR.DS = 0 is for the unique identification of the descriptor after writing.

(2) Flow of Reception Descriptor Processing

Constructing a descriptor chain requires software (see **Figure 30.15**).

In the example in the figure, the variable SWdescr (software descriptor pointer) is a structure to identify a descriptor being processed. SWdescr must be initialized after OPERATION mode is entered and a descriptor base address load request (DLR.LBAq) is executed (condition for starting the flow of software operations).

The frame_processing() function processes the stored data. The function can use SWdescr.DT to check whether processing of a frame is completed. How frame data are processed differs with the application, so create functions that handle processing in accord with the specification.

The processing section is common to all modes of reception. The number of frames processed in response to each trigger can be restricted. When multiple frames have to be processed in a batch, waiting for individual trigger boxes must be skipped for these frames.

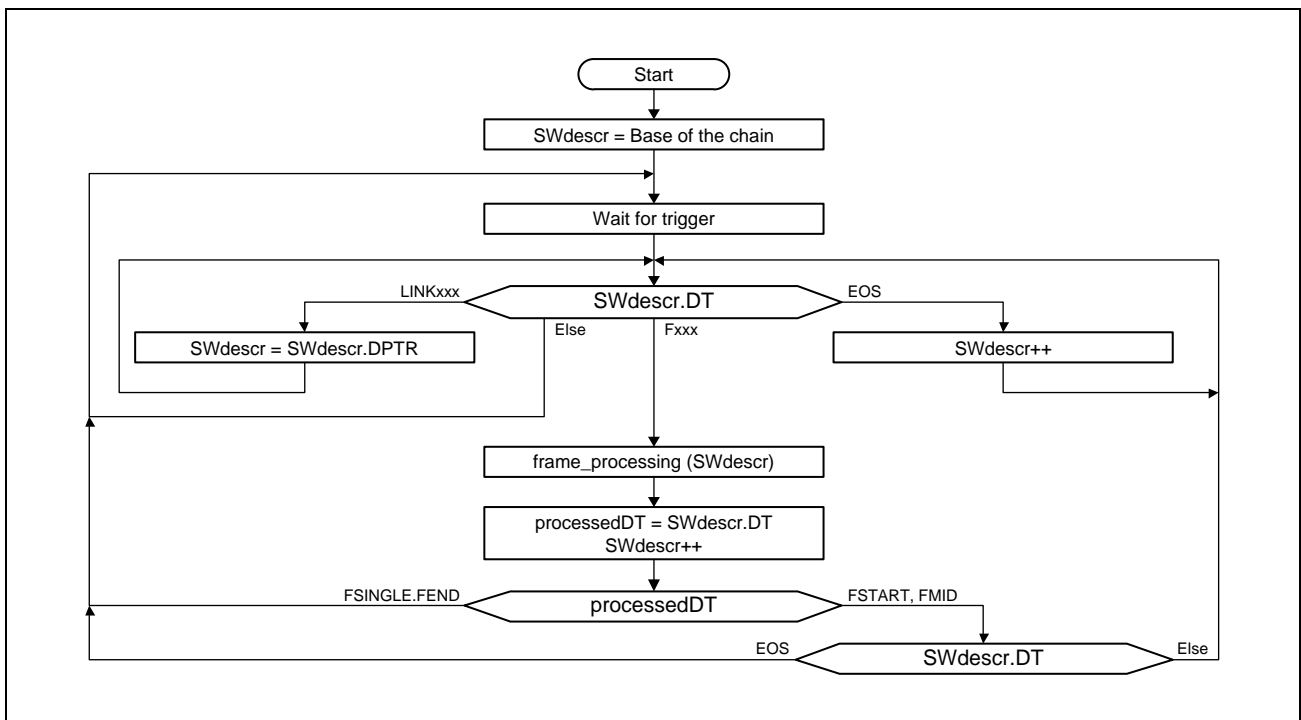

Figure 30.15 Flow of Reception Descriptor Processing

30.5.4 Transmission Control

Areas in the URAM for storing transmission descriptors must also be secured (for descriptors, see **Section 30.5.2, Descriptors**).

The DMAC fetches data from the URAM in accord with the procedure the descriptor describes. The descriptor also retains tag information once the frame has been fetched for transmission. The tag information is used to maintain the relationships between status for the software and the DMAC. The status information for transmitted frames remains accessible after their transmission is completed.

When DMAC started to transfer a frame, it reaches to TOE via Transmission FIFO and TOE FIFO. And after the calculation of transmission frame checksum by TOE, it is transferred to PHY by E-MAC. If any error information is detected by TOE or E-MAC, they are notified to DMAC and stored to MAC Status FIFO/MAC Status FIFO2. The oldest information in them is indicated to MFA/MFA2 of DMAC register.

Figure 30.16 shows the transmission data bus

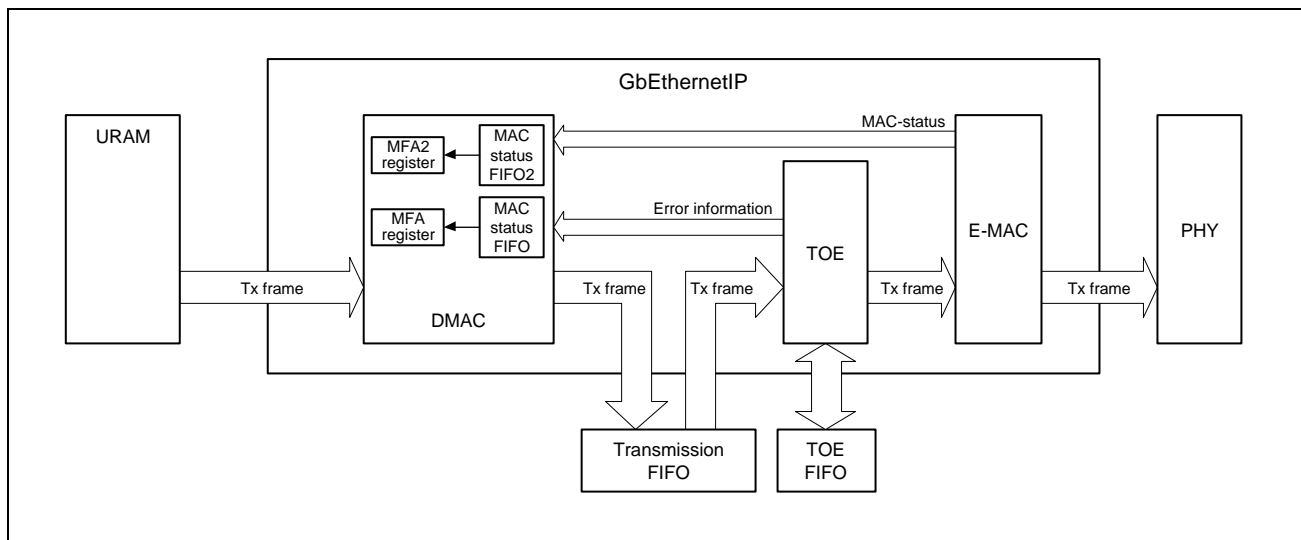

Figure 30.16 Mechanism of General Transmission

30.5.4.1 Setting Up Transmission Descriptors

(1) Transmission Descriptor Type

The type of a descriptor is defined by the descriptor type (DESCR.DT) field.

Table 30.14 shows the descriptor types used in transmission.

Table 30.14 Descriptor Types in Transmission

Descriptor Type (DESCR.DT)	Operation	Write-back
Frame Start (FSTART)	The DMAC fetches the first of the data for the divided frame and proceeds to processing of the next descriptor.	FEMPTY
Frame Middle (FMID)	The DMAC fetches the second or subsequent data for the divided frame and proceeds to processing of the next descriptor.	FEMPTY
Frame End (FEND)	The DMAC fetches the last of the data for the divided frame. The frame of data that has been fetched to the Transmission FIFO is ready for transmission by the E-MAC, and then the DMAC proceeds to processing of the next descriptor.	FEMPTY
Frame Single (FSINGLE)	The DMAC fetches the frame of data. The frame of data that has been fetched to the Transmission FIFO is ready for transmission by the E-MAC, and then the DMAC proceeds to processing of the next descriptor.	FEMPTY
Link (LINK)	Processing proceeds to the descriptor specified by DESCR.DPTR.	LEEMPTY
Fixed Link (LINKFIX)	Same as LINK	Not changed
End Of Set (EOS)	This is a transmission stop point defined by software This leads to clearing of the transmit start request bit (TCCR.TSRQ), which stops transmission. When the TCCR.TSRQ is again set to 1 (a new transmission start request is issued), processing proceeds to the next descriptor.	EEMPTY
Frame Empty (FEMPTY)	No frame data are ready for transmission This leads to clearing of the transmit start request bit (TCCR.TSRQ), which stops transmission. When the TCCR.TSRQ is again set to 1 (a new transmission start request is issued), processing starts at this descriptor.	Not changed
Link Empty (LEEMPTY)	Same as FEMPTY	Not changed
EOS Empty (EEMPTY)	Same as FEMPTY	Not changed

(2) Configuration of Transmission Frame Data Descriptors

Figure 30.17 shows the configuration of descriptors for use with transmission queues. The transmission-specific fields (DESCR.TSR, and DESCR.TAG) are described in **Table 30.15**.

For the other fields and the descriptor types, see **Section 30.5.2.6, Descriptor Type**.

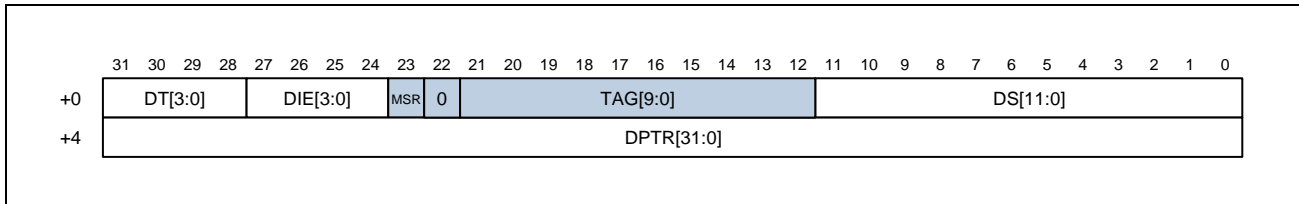

Figure 30.17 Configuration of Descriptor for a Transmitted Frame

Table 30.15 Configuration of a Transmission Descriptor

Bit Name	Function
MSR	<p>MAC Status storage Request</p> <p>This bit configures if MAC transmission status of the frame is stored in MAC status FIFO.</p> <p>0b: No status information is stored</p> <p>1b: Status information is to be kept for this frame in MAC status FIFO</p> <p>This bit is considered only if DESCR.DT = FEND or FSINGLE.</p> <p><i>Note:</i> If there is error during transmission of frame then status is always stored.</p>
TAG	<p>Frame Tag</p> <p>This TAG field is used to associate each frame data. Frame TAG is not required but is recommended.</p> <p>This bit is available while the current DESCR.DT is FEND or FSINGLE.</p>

30.5.4.2 Transmission

(1) Transmitting Frames

Setting the transmit start request bit in the transmit configuration control register (TCCR.TSRQ) starts the transfer of frames from the corresponding transmission queue.

The descriptor in the current descriptor address (CDARq.CDA) for the queue (with q = 0) is read first.

If this descriptor is a descriptor for frame transmission (FSINGLE, etc.), the DMAC fetches the frame data from the data area indicated by the descriptor, writes FEMPTY back to the descriptor type (DESCR.DT) bits to indicate completion of this processing, then proceeds to processing of the next descriptor.

If the descriptor is not for transmission, processing is as dictated by the given descriptor (for these descriptors, see the descriptions in **Section 30.5.2, Descriptors**).

If a base address load request is issued for a descriptor chain while it is being processed (by setting 1 in the LBAq bit for transmission queue q that is currently being processed in the descriptor base address load request register, DLR), processing proceeds to the new descriptor chain. Changing the chain does not interrupt frame fetching, but note that frames that have not been fetched from the old chain remain where they are.

Figure 30.18 shows descriptor processing during transmission.

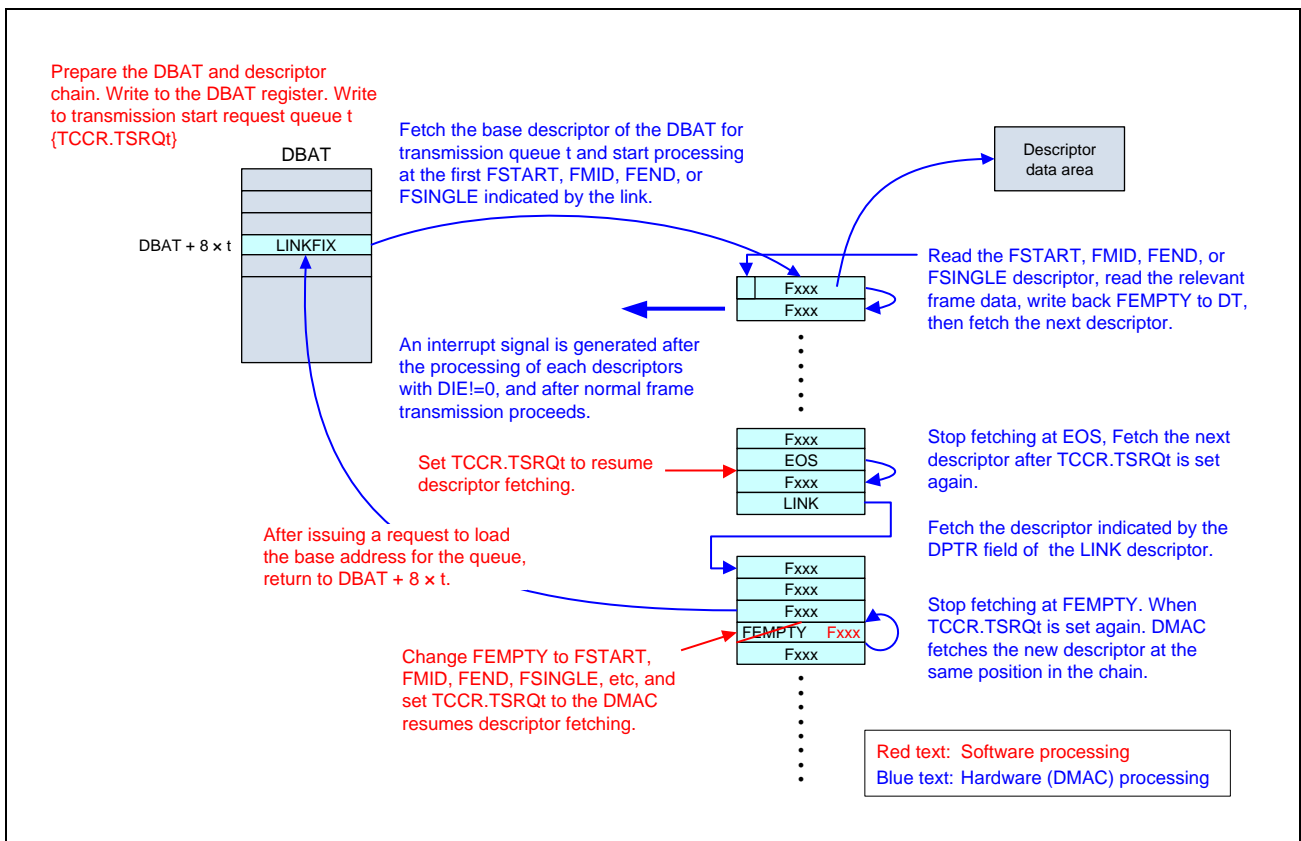

Figure 30.18 Descriptor Processing During Transmission

(2) Examples of Descriptor Usage

(1) Immediate Frame Transmission

Immediate frame transmission is a pattern in which fetching by the DMAC starts whenever software adds data to a queue. FEMPTY descriptors are used as stop points to keep the hardware and software in synchronization.

Create descriptor chains that have FEMPTY descriptors at the stop points.

Figure 30.19 shows the flow for software implementing this pattern. SW should read back written descriptor between changing FEMPTY descriptor before writing to TCCR.TSRQ.

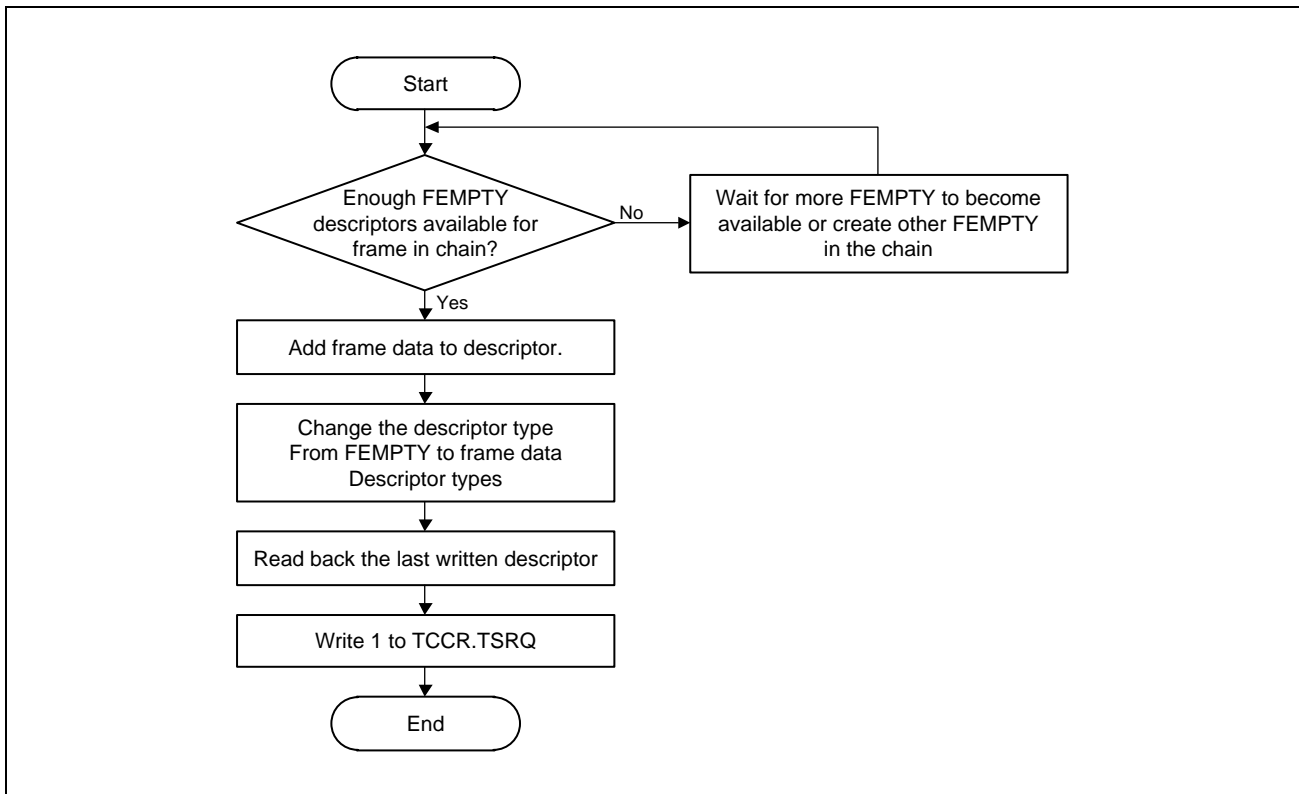

Figure 30.19 Software Flow for Immediate Frame Transmission

Figure 30.20 shows software and DMAC operations for immediate frame transmission.

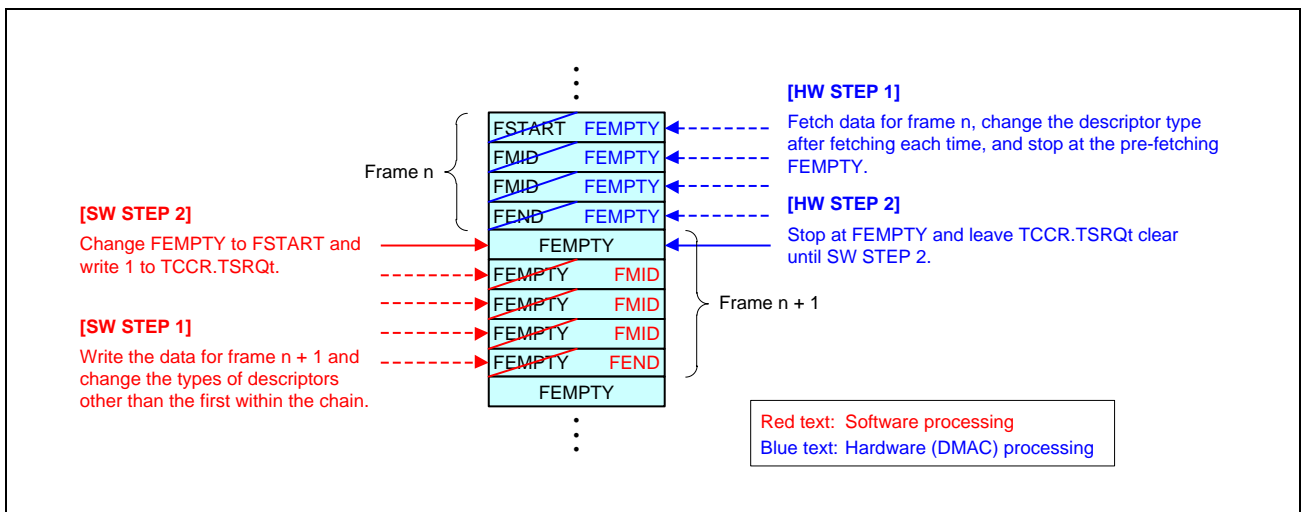

Figure 30.20 Software and DMAC Operations for Immediate Frame Transmission

(2) Frame Set Transmission with Changing of the Active Descriptor Chain

This pattern is used when data are transmitted with a delay for software control to secure bandwidth or for other reasons, rather than immediately transmitted. EOS descriptors are used for the stop points. Start by creating a descriptor chain that has a FEMPTY descriptor as its stop point.

Figure 30.21 shows the software flow in this pattern.

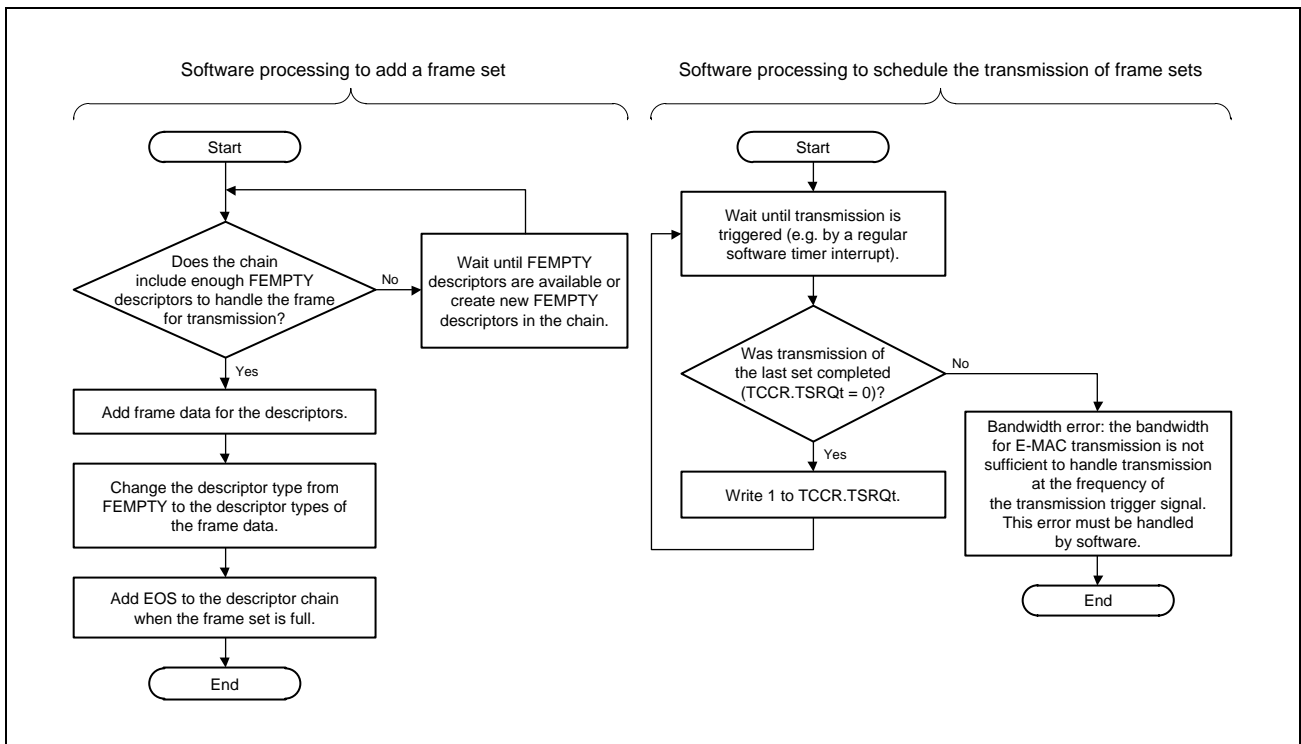

Figure 30.21 Software Flow for Frame Set Transmission with Changing of the Active Descriptor Chain

Figure 30.22 shows software and DMAC operations for frame set transmission.

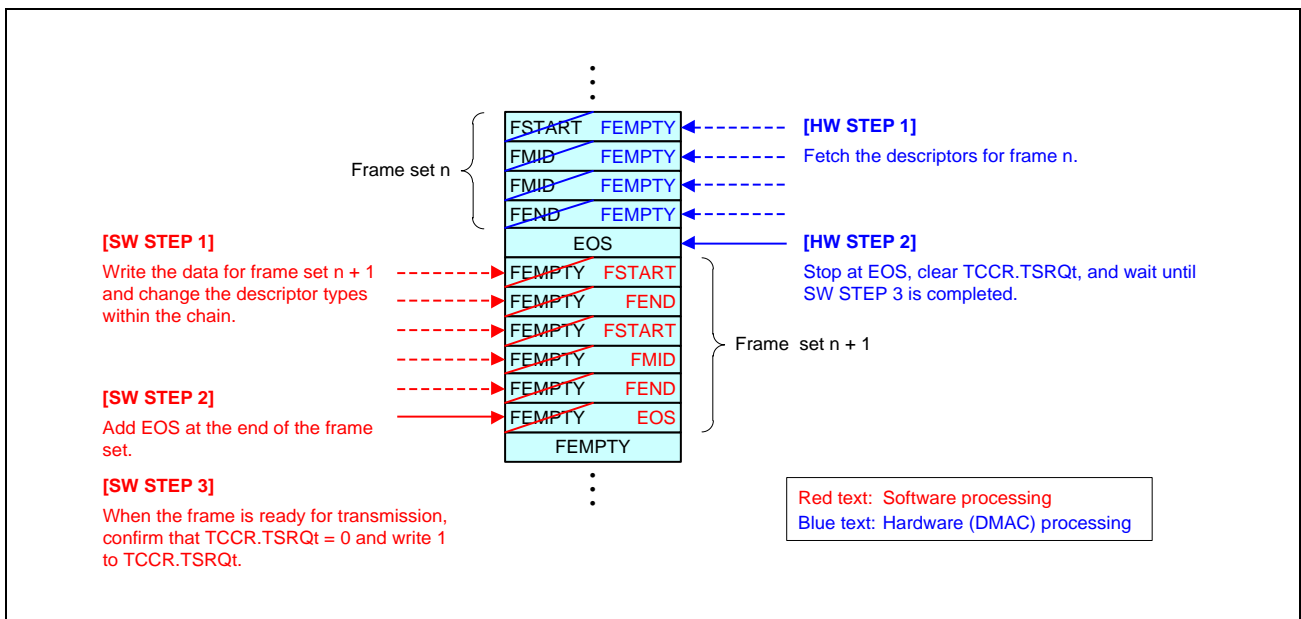

Figure 30.22 SW and DMAC Operations for Frame Set Transmission with Changing of the Active Descriptor Chain

(3) Frame Set Transmission Using a Shadow Descriptor Chain

This pattern is used when data are transmitted with a delay for software control to secure bandwidth or for other reasons, rather than immediately transmitted. Two or more descriptor chains are used. The chains are classified as active or shadow chains. EOS descriptors are used for the stop points.

Create descriptor chains that have FEMPTY descriptors at the stop points.

Figure 30.23 shows the flow for software implementing this pattern.

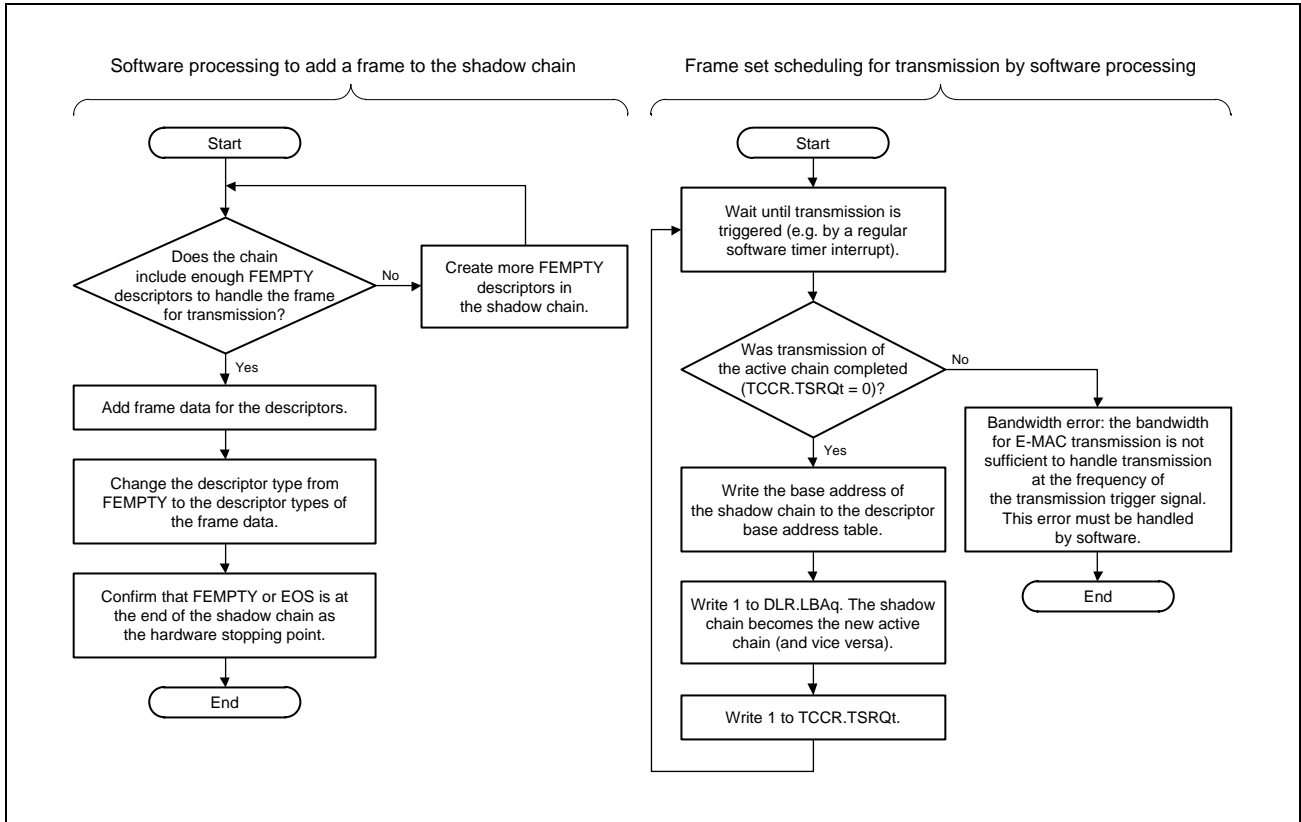

Figure 30.23 Software Flow for Frame Set Transmission Using the Shadow Descriptor Chain

Figure 30.24 shows software and DMAC operations for frame set transmission.

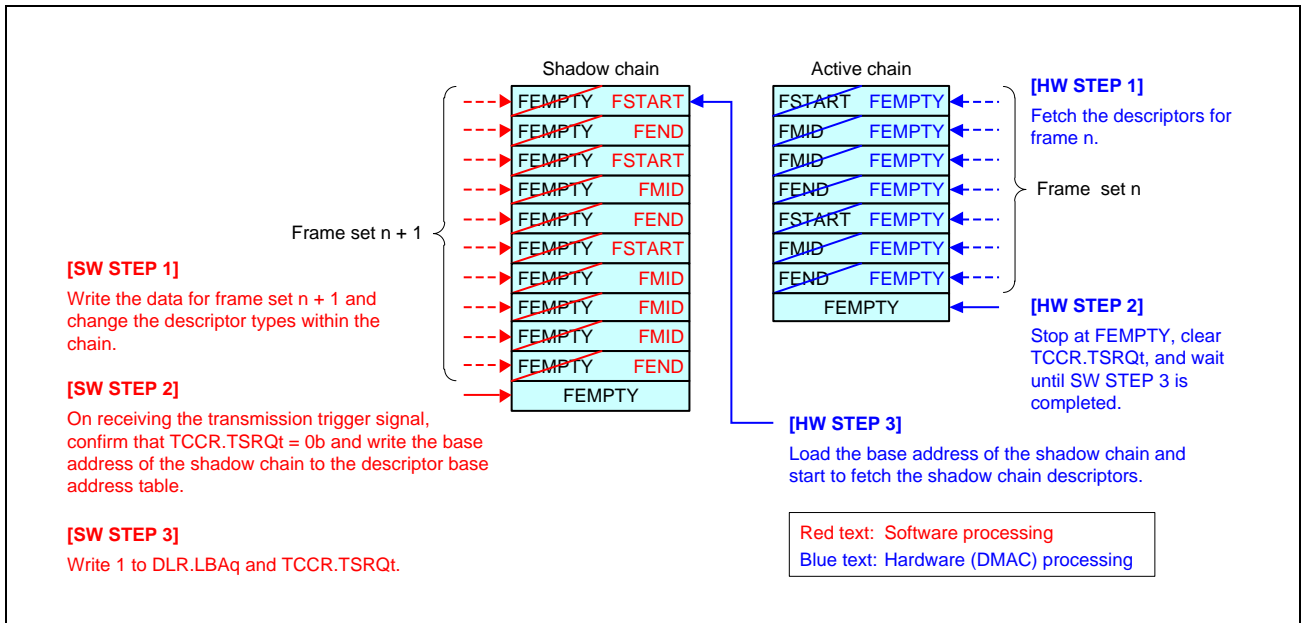

Figure 30.24 SW and DMAC Operations for Frame Set Transmission Using the Shadow Descriptor Chain

30.5.5 Integrity Checking

The DMAC can detect and identify errors produced in the processing of Ethernet frames and in the transfer of frame data for transmission and reception.

30.5.5.1 Integrity Checking in Reception

The aim of integrity checking in reception is preventing the storage of error frames in the URAM. If an error frame is stored in the URAM, software can get information to identify the frame as an error frame.

30.5.5.2 Integrity Checking in Transmission

The purpose of integrity checking in transmission is to prevent the transmission of broken frames.

Since transmission of a frame by the E-MAC can neither be stopped nor disabled once it has started, this check involves intensive monitoring for problems that can arise during fetching.

30.5.5.3 Monitoring in Both Reception and Transmission

(1) Errors in access to the URAM for reading of descriptors

The same descriptor may be processed again because the current descriptor address (CDARq.CDA) was not changed.

If this problem occurs in a divided frame, the sequence may be broken.

In reception

- The received frame will be lost.
- The same problem will occur for the next frame of data received for the same queue.

In transmission

- The transmit start request bit in the transmit configuration control register (TCCR.TSRQ) is set to 0.
- The frame will be lost from the Transmission FIFO.

Errors in access to read descriptors from the URAM are detected from the response signal of the AXI-Bus.

(2) Illegal configuration of a descriptor by an application

The same descriptor may be processed again because the current descriptor address (CDARq.CDA) was not changed.

If this problem occurs in a divided frame, the sequence may be broken.

In reception

- The received frame will be lost.
- The same problem will occur for the next frame of data received for the same queue.

In transmission

- The transmit start request bit in the transmit configuration control register (TCCR.TSRQ) is set to 0.
- The frame will be lost from the Transmission FIFO.

(3) Errors in access to the URAM for writing of descriptors

As in the case where no error occurs, the current descriptor address (CDARq.CDA) and the transmit start request bit in the transmit configuration control register (TCCR.TSRQ) are updated.

As DESC.RDT was not updated, hardware and software synchronization may have been destroyed.

Errors in access to write descriptors to the URAM are detected from the response signal of the AXI-Bus.

30.5.5.4 Monitoring in Reception

(1) Errors in access to the URAM for writing of data

- As in the case where no error occurs, the current descriptor address (CDARq.CDA) is updated.
- DESC.EI is set to indicate incorrect contents.
- This problem occurring in a divided frame may break the descriptor sequence, making the queue unusable.

Errors in access to write data or descriptors to the URAM are detected from the response signal of the AXI-Bus.

(2) Error of the Reception FIFO

- Received frames are all invalidated.
- All frames stored as received frames are discarded. At this time, the number of frames and queue information cannot be captured.

If the Reception FIFO RAM faults, DMAC detects the fault as error of the Reception FIFO.

30.5.5.5 Monitoring in Transmission

(1) Errors in Access for Reading Data from the URAM

- Data that have already been fetched are discarded from the Transmission FIFO.
- When an error of this type occurs during processing of an FSINGLE or FEND descriptor:
As in the case where no error occurs, the current descriptor address (CDARq.CDA) and the transmit start bit in the transmit configuration control register (TCCR.TSRQ) are updated. Fetching resumes after the error frame.
- When an error of this type occurs during processing of an FSTART or FMID descriptor:
The current descriptor address (CDARq.CDA) is not updated.
The transmit start bit in the transmit configuration control register (TCCR.TSRQ) is set to 0.

Errors in access to read data from the URAM are detected from the response signal of the AXI-Bus.

(2) Overflow of the Transmission FIFO

- As in the case where no error occurs, the current descriptor address (CDARq.CDA) and the transmit start bit in the transmit configuration control register (TCCR.TSRQ) are updated. Fetching resumes after the error frame.
- The frame will be discarded from the FIFO.

(3) Damaged Data in the Transmission FIFO

- Fetching is not affected by damaged data.
- Since damaged data from the FIFO is only detected during frame transmission, an error frame may be transmitted.
- The information of MAC Status FIFO and MAC Status FIFO2 will be inconsistent.

If damaged data in the Transmission FIFO is an error due to the Transmission FIFO, this is detected by the DMAC.

30.5.6 Checksum Calculation

TOE calculates Checksum of received frames from E-MAC. And then it is outputted to DMAC. TOE also calculates Checksum of transmission frames from DMAC. And then it is outputted to E-MAC.

To use this function, configure E-MAC as CRC Pass Through Mode (CXR20.RCPT = 1).

TOE supports Checksum Calculation for following part of frames. See **Section 30.5.6.4** for about the details of Supported Frames.

- IPv4 Header
- IPv4 TCP/UDP/ICMP
- IPv6 TCP/UDP/ICMP

30.5.6.1 Checksum Calculation handling

(1) Reception Handling

The result of Checksum Calculation is attached to last 4 bytes of Ethernet Frames like **Figure 30.25**. And then the handled frames are transferred to memory by DMAC. If the frame does not have checksum error at the part of IPv4 Header or TCP/UDP/ICMP, the value of “H’0000” is attached to each part as the result of Checksum Calculation. The case of Unsupported Frame, the value of “H’FFFF” is attached. For example, if the part of IP Header is unsupported, “H’FFFF” is set to both field of IPv4 Header and TCP/UDP/ICMP. The case of IPv6, IPv4 Header field is always set to “H’FFFF”. And the set value of TCP/UDP/ICMP field depends on configuration for support conditions.

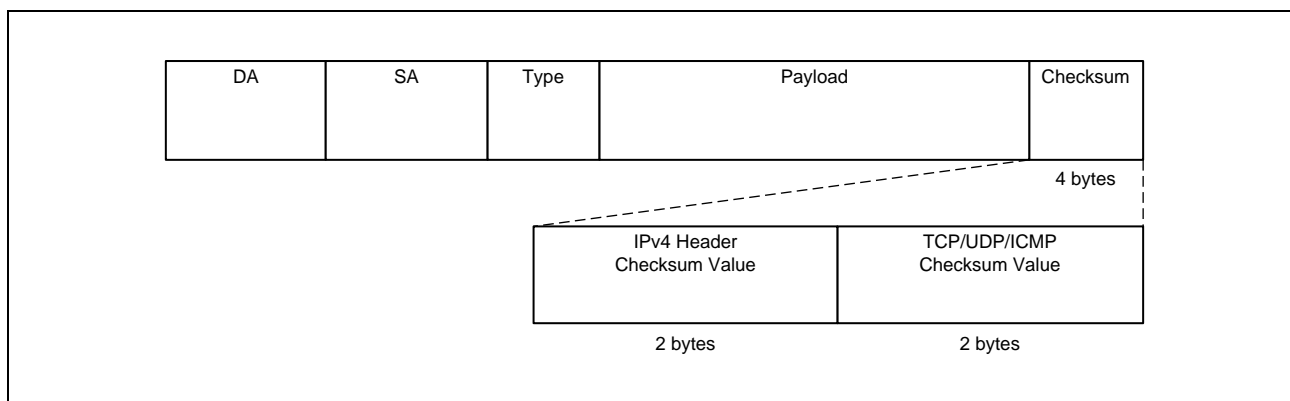

Figure 30.25 The field of checksum attaching field (Ex. Ethernet Frame of DIX)

(2) Transmission Handling

The result of Checksum Calculation is set to the Checksum field of each IPv4 Header/TCP/UDP/ICPM. For the Unsupported Frames, those fields are not changed. If a transmission frame is an UDP frame of IPv4 and its Checksum value in the UDP Header field is “H’0000”, TOE does not calculate Checksum for UDP part of this frame. Because Checksum for IPv4 UDP frame is defined as optional function in standards. If a transmission IPv4 UDP frame does not need to Checksum Value, set “H’0000” to the Checksum field in the UDP Header.

30.5.6.2 Error Notification

When TOE detects any errors by Checksum Calculation, the error information is notified to DMAC. The errors are detected by TOE are followings:

- Unsupported Transmission Frame Error (This error information is indicated to “MFA” register)
- Unsupported Reception Frame Error (This error information is stored to Descriptor by Write Back)
- Reception Frame has Checksum Error (This error information is stored to Descriptor by Write Back)

30.5.6.3 Individually Configuration by the frame type

The Enable/Disable setting of Checksum Calculation is configurable by CSR1 and CSR2 register. And CSR1 and CSR2 register are able to configure Enable/Disable setting individually for frame type. For example, it is possible to disable the checksum calculation for only UDP part of IPv4 frame.

The relationship between the Frame Type and Error Notification to DMAC are indicated at **Table 30.16** and **Table 30.17**. **Table 30.16** is for Transmission Frames. **Table 30.17** is for Reception Frames. The condition of both tables is that the checksum calculation for all frame type is enabled by CSR1 and CSR2 register.

If the checksum calculation of each Frame Type is configured as Disable individually by CSR1 and CSR2 register, the operation is followings. (Following descriptions are for the normal frames)

(1) Disabled Transmission Checksum Calculation

TOE notifies an Unsupported Transmission Frame Error to DMAC. And the Checksum Values which Type is configured as “Disable” are not changed.

(2) Disabled Reception Checksum Calculation

The frames which have Disabled configuration Types are handled as Unsupported Frame. So, the error notification to DAMC is same as the case of Unsupported Frames.

If the other checksum field which is configured as Enable has Checksum Error, Received Checksum Error is notified to DMAC. Received Unsupported Error also is notified. The value of “H’FFFF” is set to the checksum field which is configured as Disable.

Table 30.16 Relationship between Transmission Frame Type and Error Notification to DMAC

Transmission Frame Type						Checksum Operation		
VLAN-tag		IP		Transport protocol		Error Notification to DMAC	Checksum Value	
Number of tags	TPID	Protocol	Condition	Protocol	Condition	Unsupported Frame Error	IPv4 Header	TCP/UDP/ICMP
0 or 1	Nothing or H'8100	IPv4	Not Fragmented Packet	TCP/ICMP	—	Non-Asserted	Calculated Value	Calculated Value
				UDP	Checksum Field is not H'0000	Non-Asserted	Calculated Value	Calculated Value
					Checksum Field is H'0000	Non-Asserted	Calculated Value	Through (H'0000)
				Except TCP/ICMP/UDP	—	Asserted	Calculated Value	—
				Fragmented Packet	don't care	don't care	Asserted	Calculated Value
		IPv6	Non-Extended Header or The number of Supported Extended Header is from 1 to 8* ¹	TCP/ICMP	—	Non-Asserted	—	Calculated Value
				UDP	—	Non-Asserted	—	Calculated Value
				Except TCP/ICMP/UDP	—	Asserted	—	—
			The number of Supported Extended Header is 9 or more* ¹	don't care	don't care	Asserted	—	—
			Has Unsupported Extended Header* ¹	don't care	don't care	Asserted	—	—
Except IPv4/IPv6	—	don't care	don't care	Asserted	—	—		
1	Except H'8100	don't care	don't care	don't care	don't care	Asserted	—	—
2 or more	don't care	don't care	don't care	don't care	don't care	Asserted	—	—
Illegal Frames* ²						Asserted	—	—

Note 1. See the **Section 30.5.6.4** for about the Supported Extended Headers.

Note 2. The Frame Length is shorter than the result of Frame Analysis by TOE.

Table 30.17 Relationship between Reception Frame Type and Error Notification to DMAC

Reception Frame Type						Checksum Operation					
VLAN-tag		IP		Transport protocol		Field of Checksum Error	Error Notification to DMAC		Checksum Value		
Number of tags	TPID	Protocol	Condition	Protocol	Condition		Checksum Error	Unsupported Frame Error	IPv4 Header	TCP/UDP/ICMP	
0 or 1	Nothing or H'8100	IPv4	Not Fragmented Packet	TCP/ICMP	—	Non-Error	Non-Asserted	Non-Asserted	H'0000	H'0000	
					—	IPv4 Header	Asserted	Non-Asserted	Calculated Value	H'0000	
					—	TCP/ICMP	Asserted	Non-Asserted	H'0000	Calculated Value	
					—	IPv4 Header and TCP/ICMP	Asserted	Non-Asserted	Calculated Value	Calculated Value	
				UDP	Checksum Field is not H'0000	Non-Error	Non-Asserted	Non-Asserted	H'0000	H'0000	
						IPv4 Header	Asserted	Non-Asserted	Calculated Value	H'0000	
						UDP	Asserted	Non-Asserted	H'0000	Calculated Value	
					IPv4 Header and UDP	Asserted	Non-Asserted	Calculated Value	Calculated Value		
				Checksum Field is H'0000	Non-Error	Non-Asserted	Non-Asserted	H'0000	H'FFFF		
					IPv4 Header	Asserted	Non-Asserted	Calculated Value	H'FFFF		
				Except TCP/ICMP/UDP	—	Non-Error	Non-Asserted	Asserted	H'0000	H'FFFF	
					IPv4 Header	Asserted	Asserted	Calculated Value	H'FFFF		
				Fragmented Packet	don't care	don't care	Non-Error	Non-Asserted	Asserted	H'0000	H'FFFF
					don't care	don't care	IPv4 Header	Asserted	Asserted	Calculated Value	H'FFFF
		IPv6	Non-Extended Header or The number of Supported Extended Header is from 1 to 8*1	TCP/ICMP	—	Non-Error	Non-Asserted	Non-Asserted	H'FFFF	H'0000	
					—	TCP/ICMP	Asserted	Non-Asserted	H'FFFF	Calculated Value	
				UDP	Checksum Field is not H'0000	Non-Error	Non-Asserted	Non-Asserted	H'FFFF	H'0000	
						UDP	Asserted	Non-Asserted	H'FFFF	Calculated Value	
				Checksum Field is H'0000	—	Asserted	Non-Asserted	H'FFFF	H'FFFF		
					—	Non-Asserted	Asserted	H'FFFF	H'FFFF		
Except TCP/ICMP/UDP	—			—	Non-Asserted	Asserted	H'FFFF	H'FFFF			
	—			—	Non-Asserted	Asserted	H'FFFF	H'FFFF			
The number of Supported Extended Header is 9 or more*1	don't care			don't care	—	Non-Asserted	Asserted	H'FFFF	H'FFFF		
Has Unsupported Extended Header*1	don't care			don't care	—	Non-Asserted	Asserted	H'FFFF	H'FFFF		
Except IPv4/IPv6	—	don't care	don't care	—	Non-Asserted	Asserted	H'FFFF	H'FFFF			
1	Except H'8100	don't care	don't care	don't care	don't care	—	Non-Asserted	Asserted	H'FFFF	H'FFFF	
2 or more	don't care	don't care	don't care	don't care	don't care	—	Non-Asserted	Asserted	H'FFFF	H'FFFF	
Illegal Frames*2						—	Non-Asserted	Asserted	H'FFFF	H'FFFF	

Note 1. See the **Section 30.5.6.4** for about the Supported Extended Headers.

Note 2. The Frame Length is shorter than the result of Frame Analysis by TOE. Or the case of E-MAC detected Errors.

30.5.6.4 Supported Frame for Checksum Calculation

Following Frames are example of Supported/Unsupported Frame Formats for Checksum Calculation.

(1) For IPv4 Checksum Calculation

Figure 30.26 is Supported Frame Format for the Checksum Calculation of IPv4 Header and IPv4 TCP/UDP/ICMP.

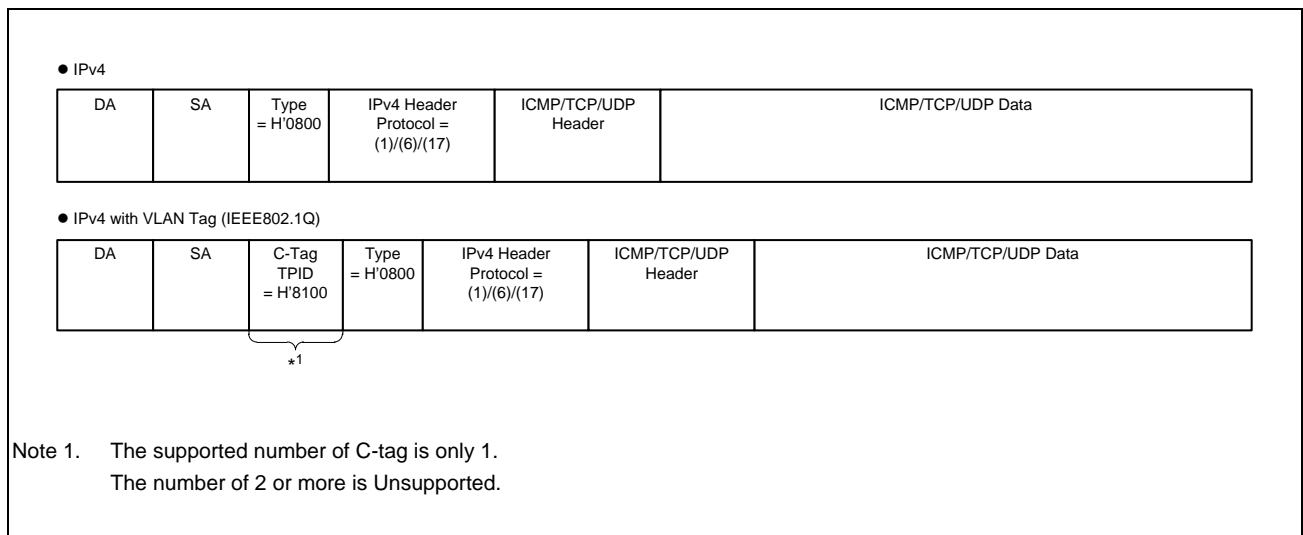

Figure 30.26 Supported Frame Format for IPv4 Checksum Calculation

(2) For IPv6 Checksum Calculation

Figure 30.27 is Supported Frame Format for the Checksum Calculation of IPv6 TCP/UDP/ICMP.

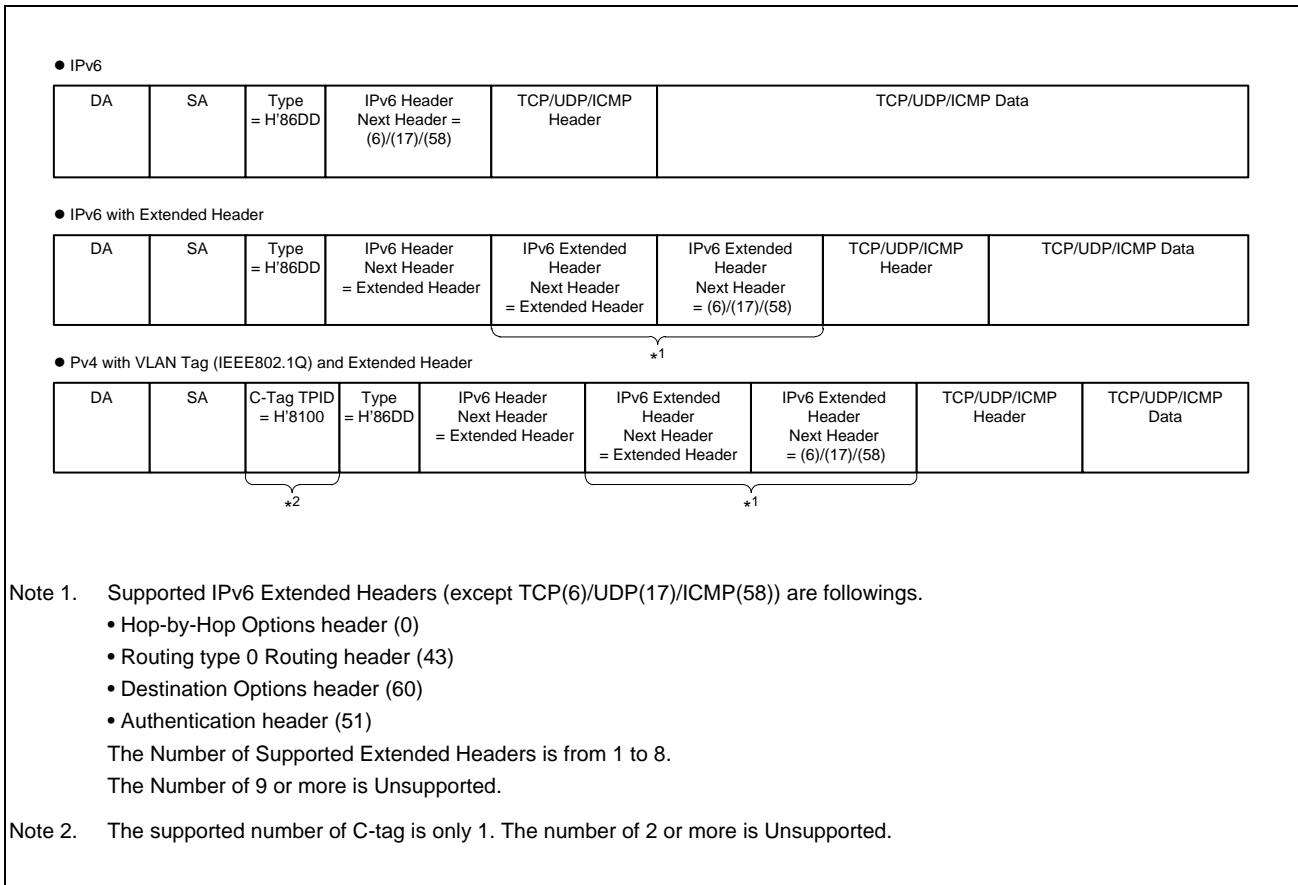

Figure 30.27 Supported Frame Format for IPv6 Checksum Calculation

(3) Unsupported Frame Format (example)

Figure 30.28 is an Example Unsupported Frame Format.

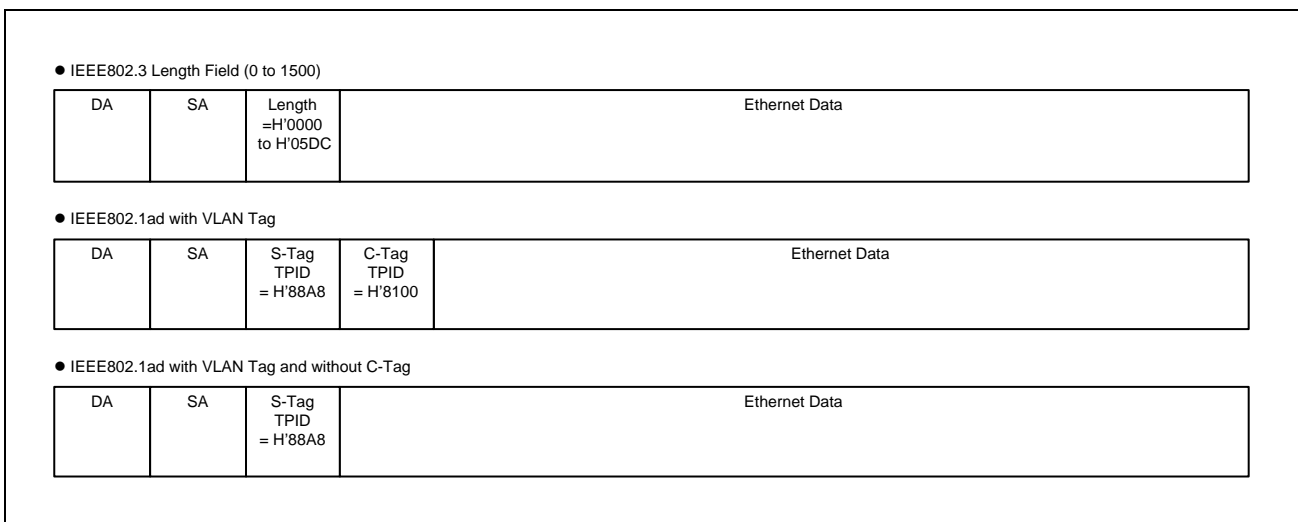

Figure 30.28 Unsupported Frame Format (example)

30.5.6.5 Checksum Calculation Flow

Figure 30.29 and Figure 30.30 are Flows for Checksum Calculation by TOE.

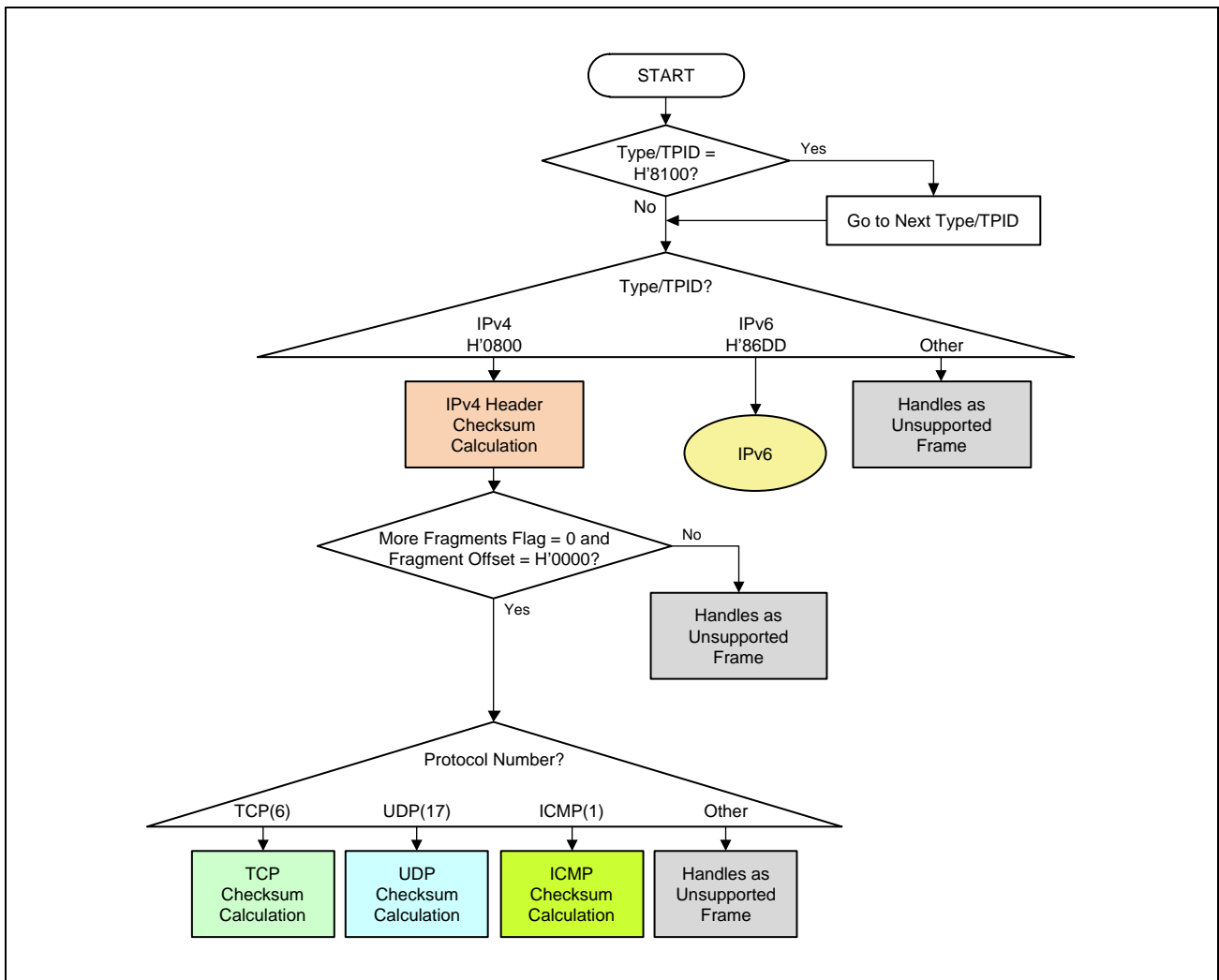

Figure 30.29 Checksum Calculation Flow (Part1)

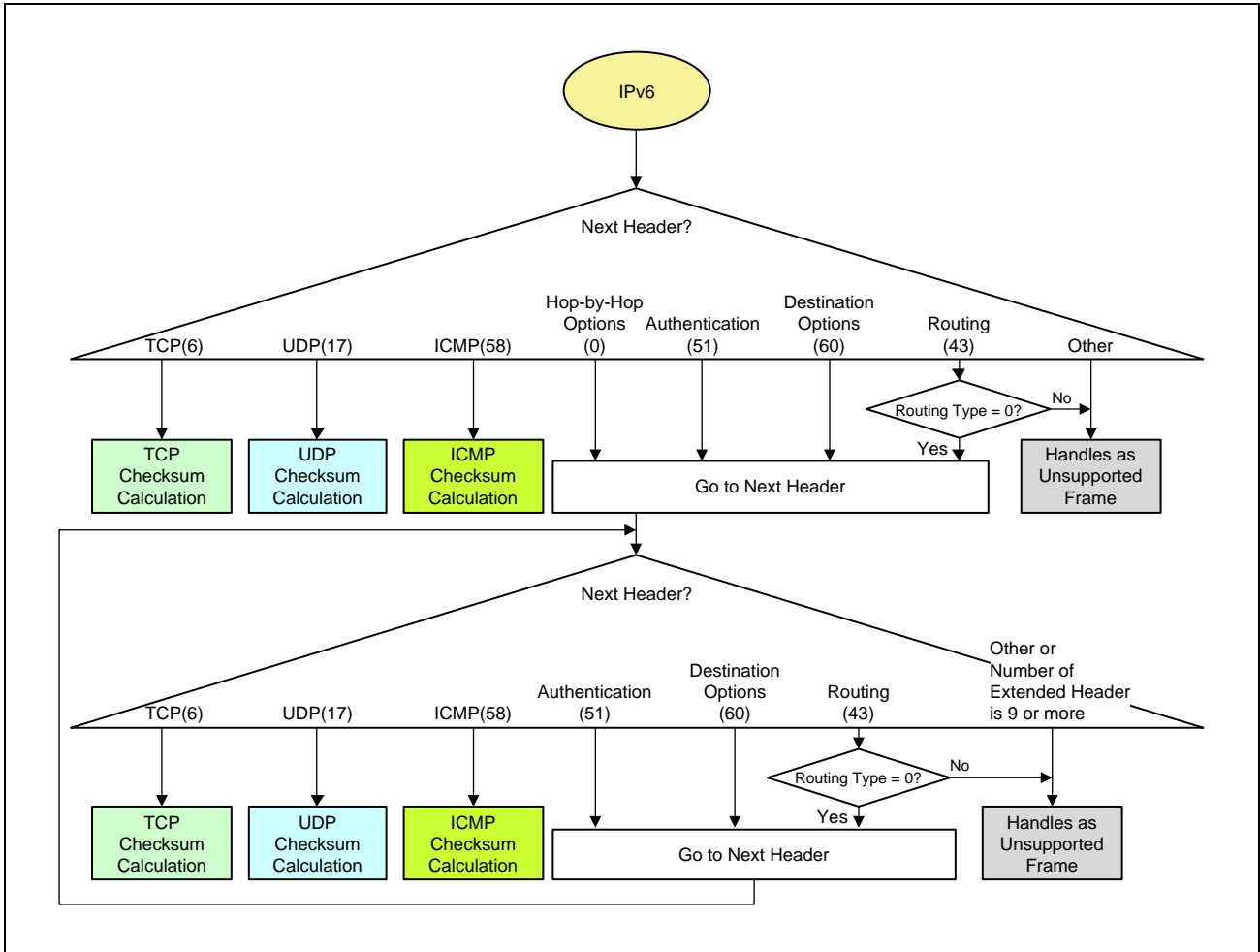

Figure 30.30 Checksum Calculation Flow (Part2)

30.5.7 Received Frame Filter

TOE has Received Frame Filters. When TOE received the frame which is not match to filters, TOE discards (abort) that frame. TOE is also able to assert an interrupt if TOE received the frame which is match to filters.

The Possible Configuration of Filter Condition are followings.

- Ethernet Type
- IP Protocol No.
- UDP destination port No.
- Destination MAC address (Unicast)
- Destination MAC address (Broadcast)
- Destination MAC address (Multicast)
- ARP Request of Local Station
- Neighbor Solicitation of Local Station
- Except IPv6 Next Header (Analyzable)

30.5.7.1 Supported Frame for Received Frame Filter

Followings are Supported /Unsupported Frame Formats by Received Frame Filter.

(1) For IPv4 Frame Filter

Figure 30.31 is Supported Frame format of IPv4.

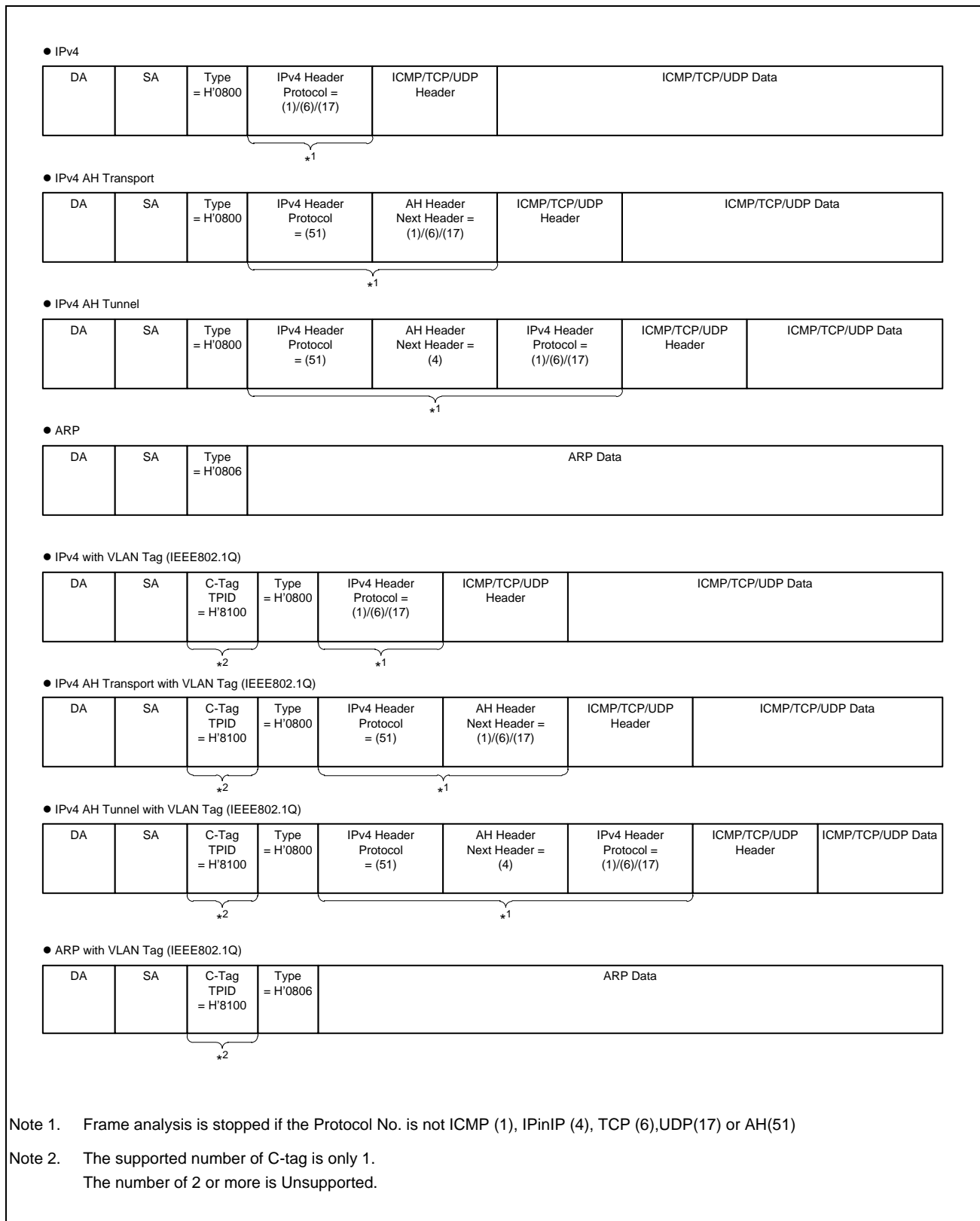

Figure 30.31 Supported Frame of IPv4

(2) For IPv6 Frame Filter

Figure 30.32 is Supported Frame format of IPv6.

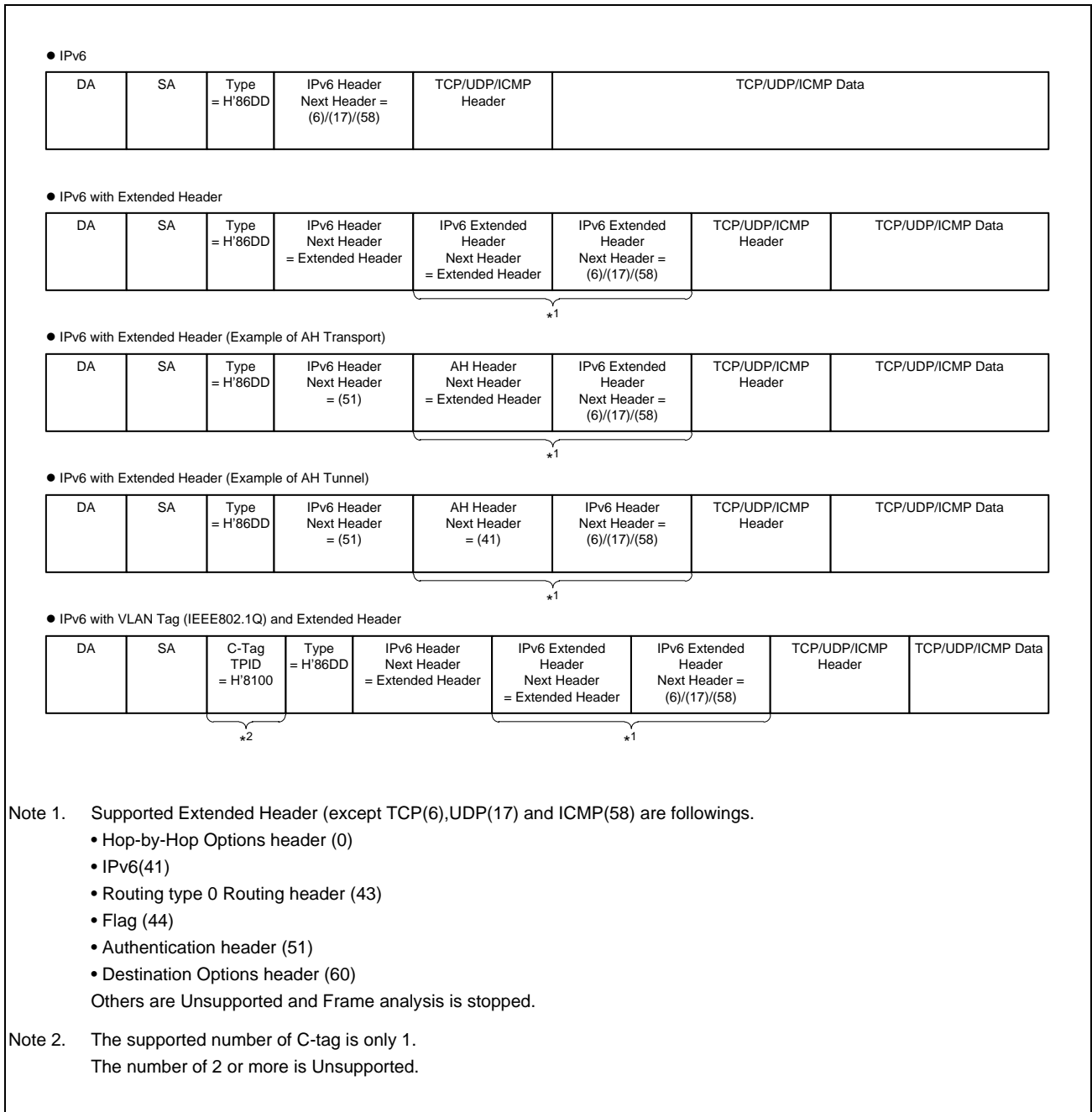

Figure 30.32 Supported Frame Format of IPv6

(3) Unsupported Frame Format (Example)

Figure 30.33 is Example Unsupported Frame Format.

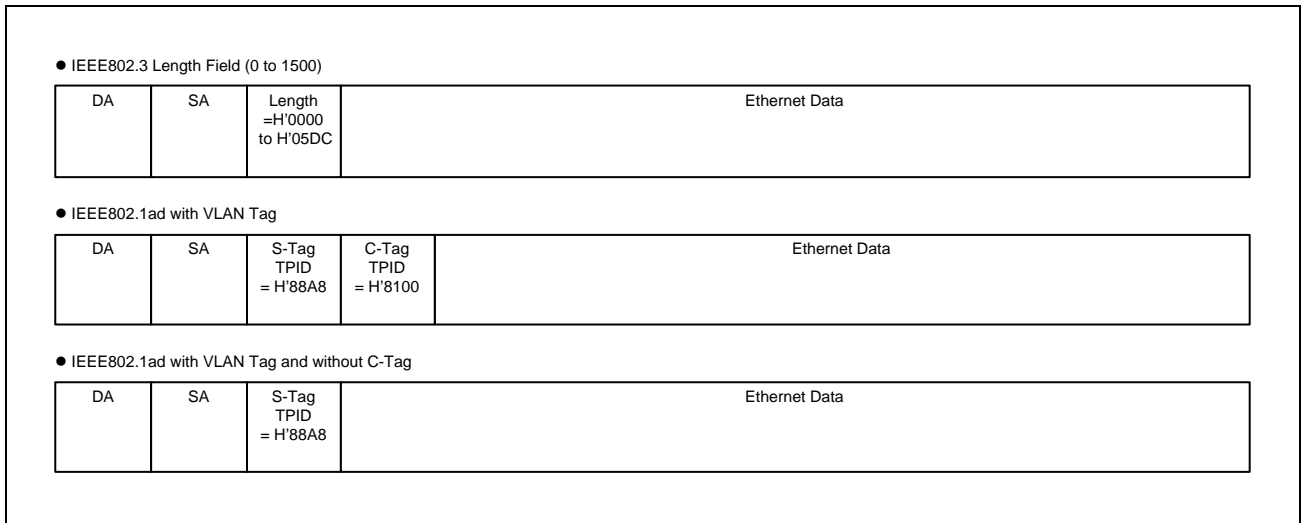

Figure 30.33 Example Unsupported Frame Format

30.5.7.2 Received Frame Filtering Flow

Figure 30.34 to Figure 30.40 are Received Frame Filtering Flows.

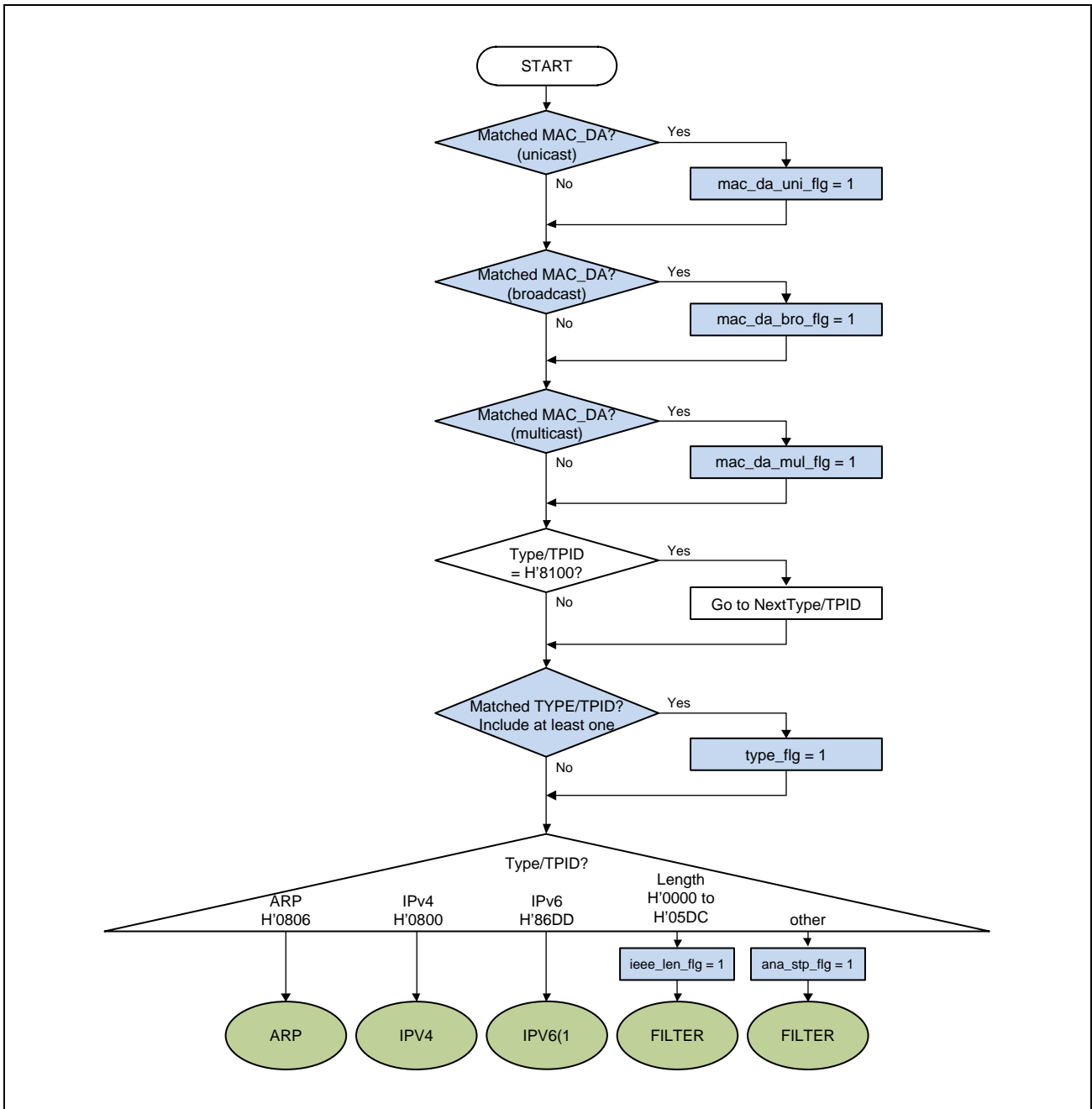

Figure 30.34 Received Frame Filtering Flow (Part1)

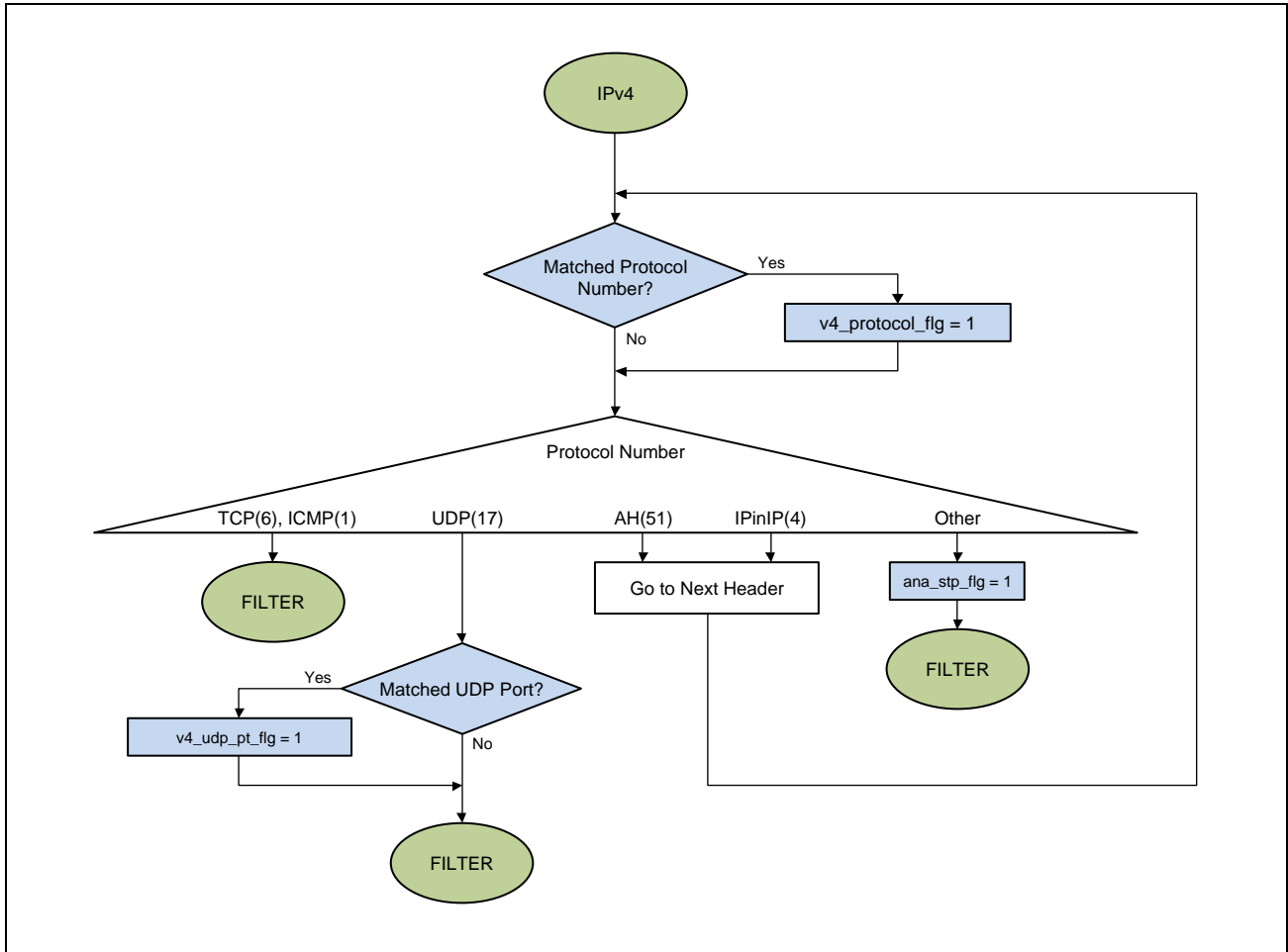

Figure 30.35 Received Frame Filtering Flow (Part2)

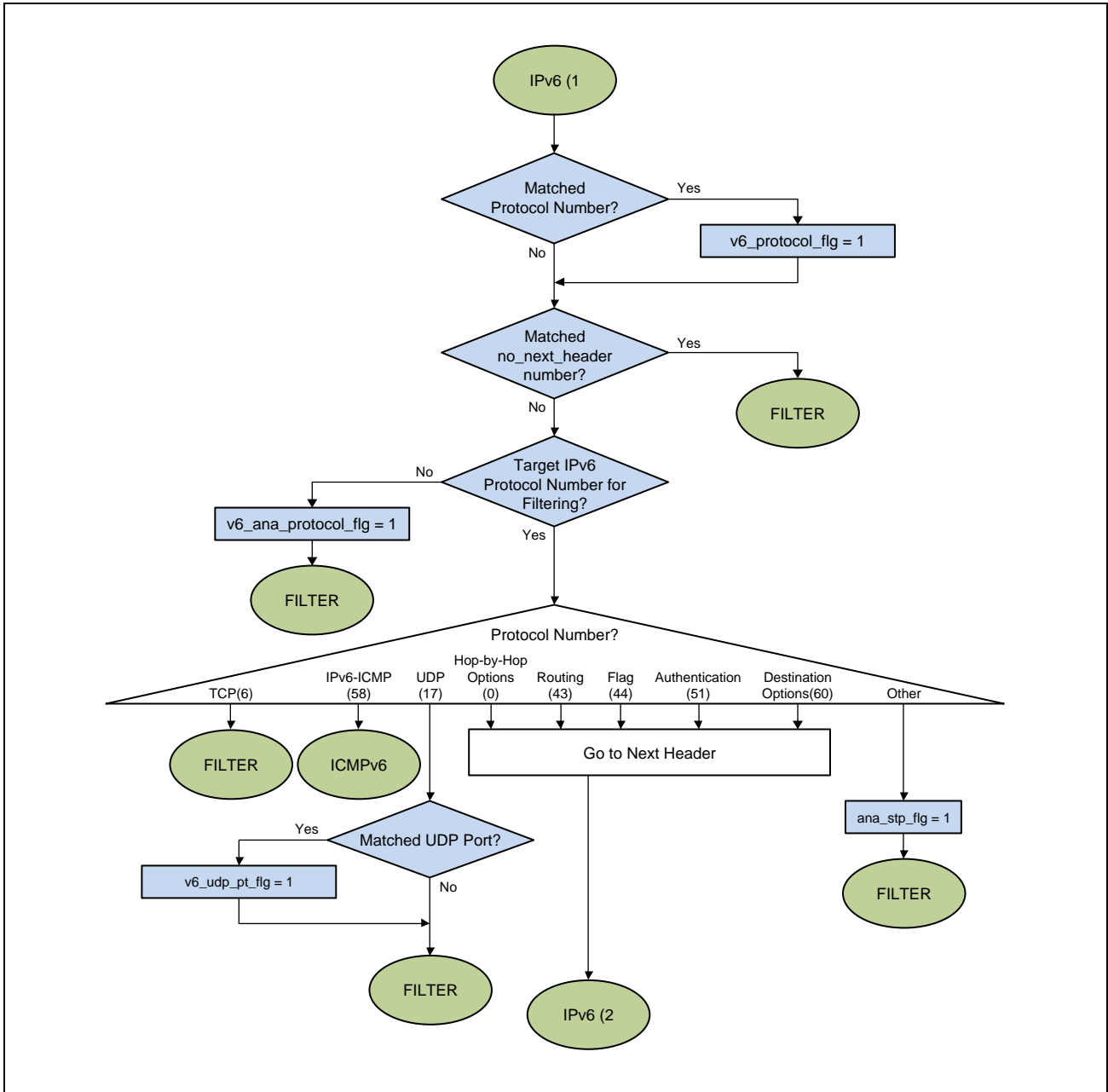

Figure 30.36 Received Frame Filtering Flow (Part3)

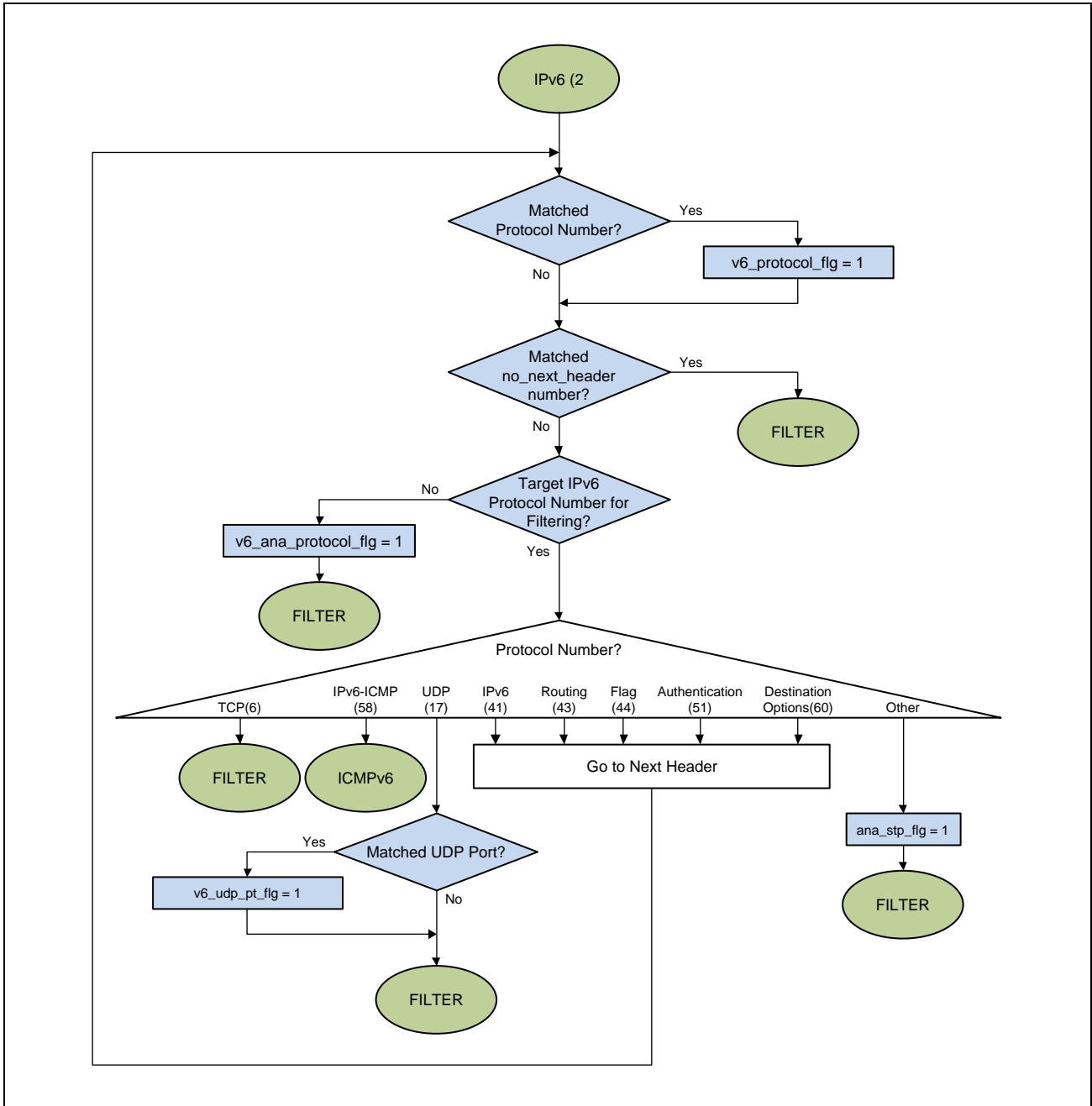

Figure 30.37 Received Frame Filtering Flow (Part4)

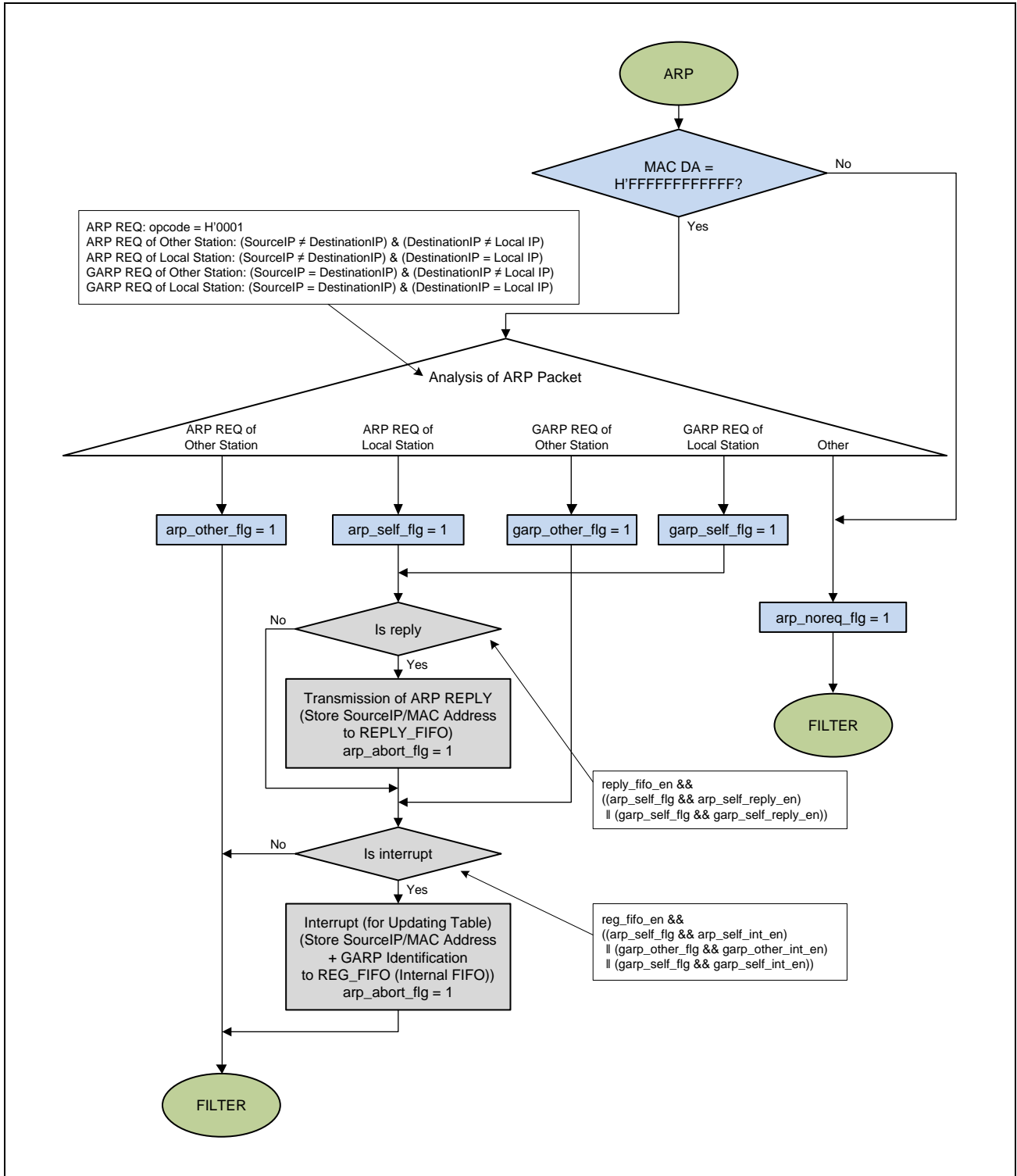

Figure 30.38 Received Frame Filtering Flow (Part5)

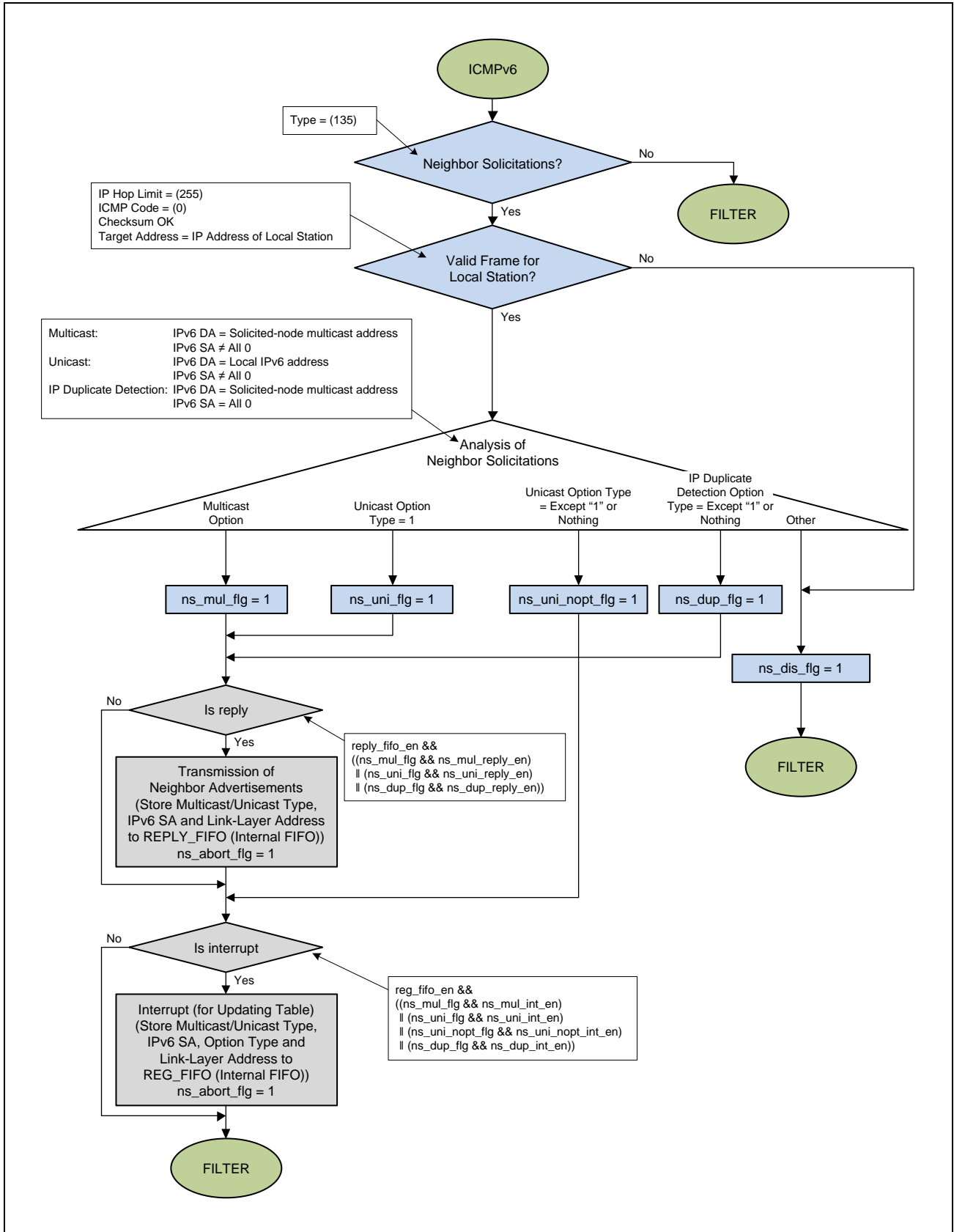

Figure 30.39 Received Frame Filtering Flow (Part6)

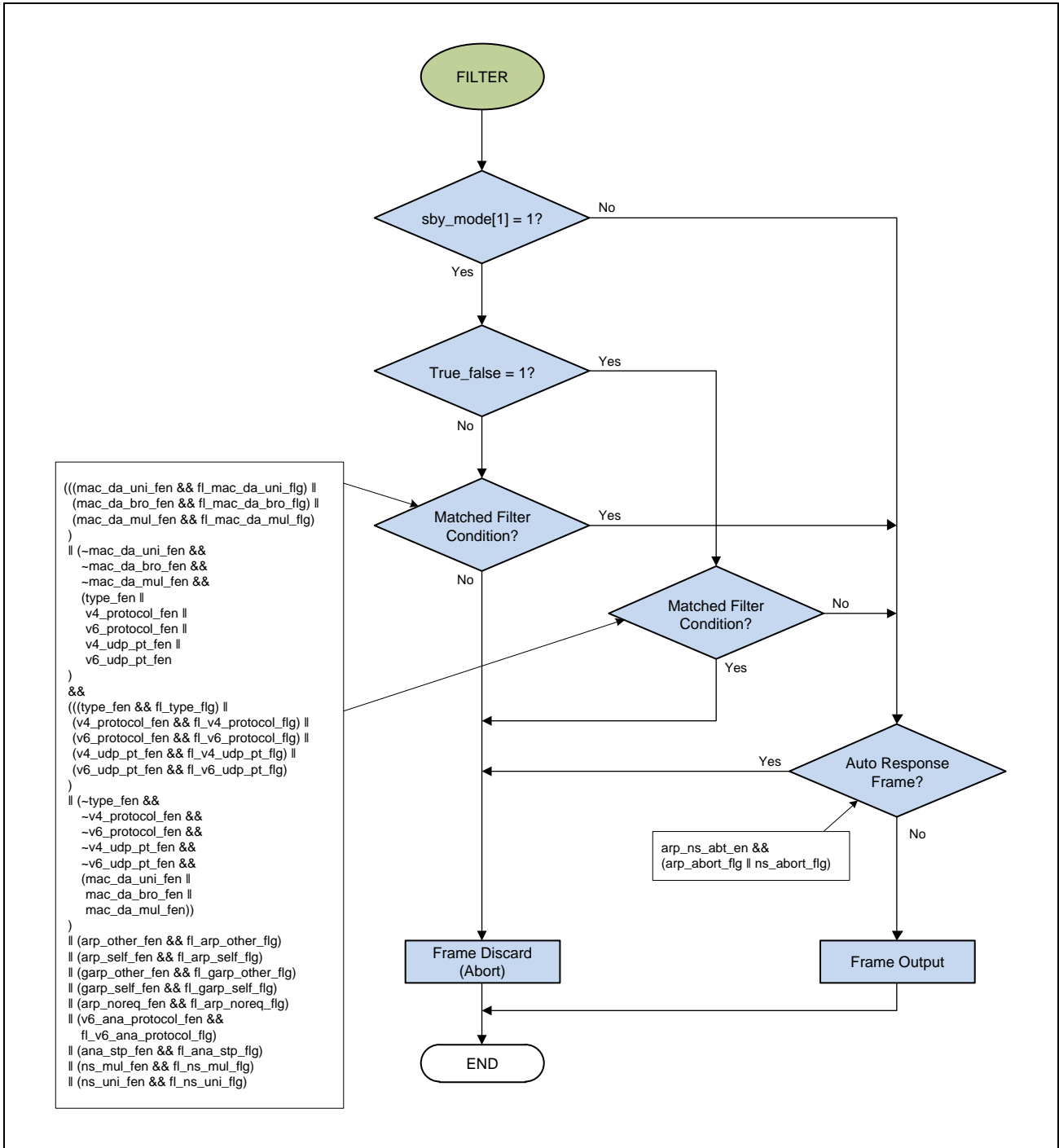

Figure 30.40 Received Frame Filtering Flow (Part7)

30.5.7.3 Filtering and Interrupts

Figure 30.41 is an overview for the function of Filtering and Interrupt.

TOE has flags for each filter conditions. When they match filter configurations of CSFR1*, each flag is set.

CSFR00 controls the action (discard or transmit) for the frames which are configured that Filtering is Enable. The filter condition relationship between “Match/Unmatch” and “Discard/Transmit” is configured by CSFR00.true_false.

The Enable/Disable configuration for discarding frame is controllable in a lump by CSFR00.sby_mode [1:0].

The flag status of each filter’s conditions is indicated to CSFR20 and outputted as interrupt. And the mask control for each interrupt is configured by CSFR21.

TOE has flags of each filter’s conditions for Filtering and Interrupt. The set condition of flags for each function is same. But clear condition is different. (The flags for Filtering are cleared at the top of frame. The flags for Interrupt are cleared by write access to the interrupt status registers.) And TOE also has Interrupt Flag which indicates the Received Frame was transmitted from TOE to DMAC without discarding by filtering conditions.

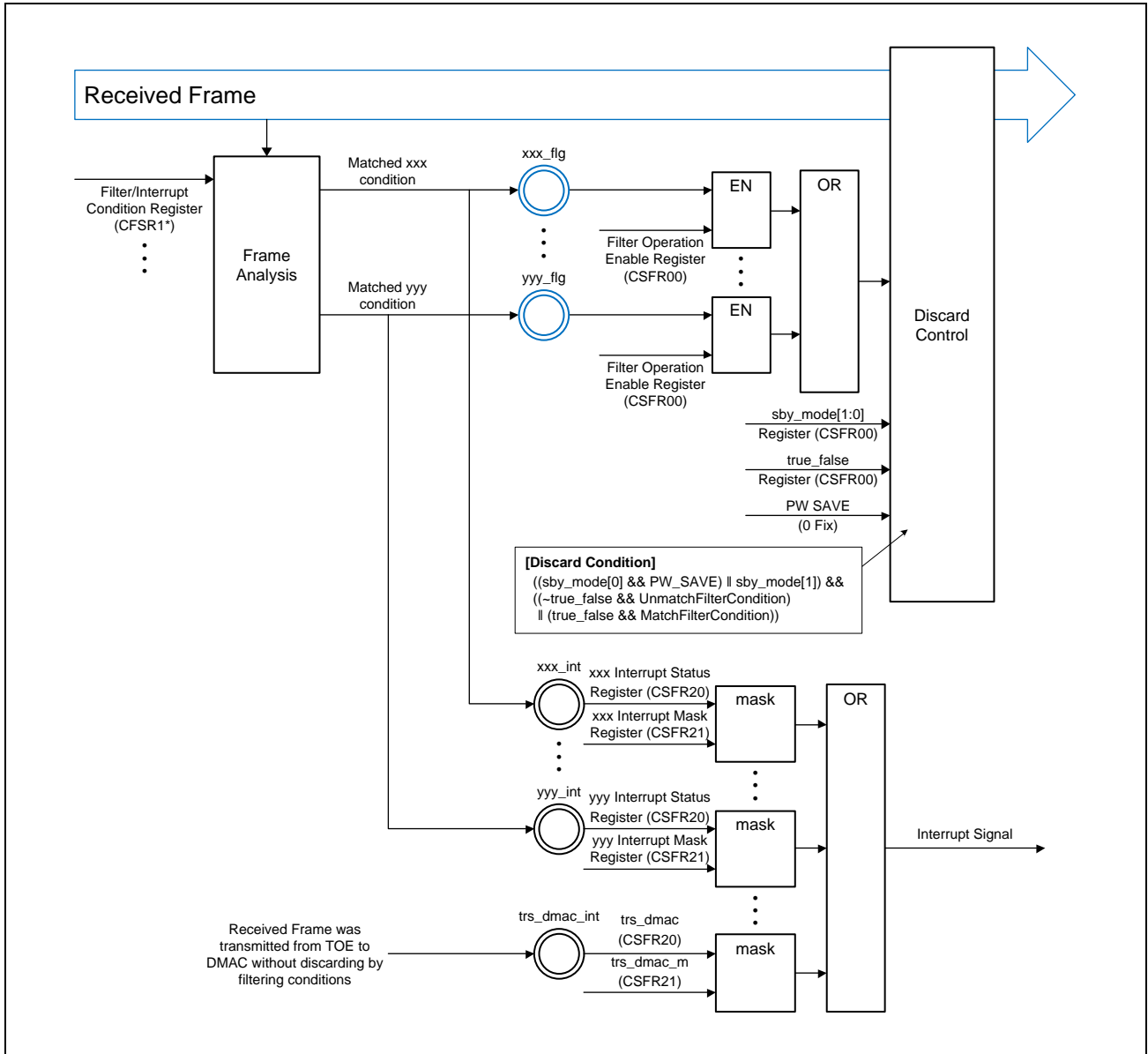

Figure 30.41 Overview of Filtering and Interrupt

30.5.8 Auto Response

TOE has following automatic responding functions.

- When TOE received ARP request for Local Station, it transmits ARP reply automatically.
- When TOE received Neighbor Solicitation for Local Station, it transmits Neighbor Advertisement automatically.

TOE also has following interrupt functions for updating ARP Table/Cache or responding function by software.

- When TOE received ARP request for Local Station, it asserts interrupt and indicates packet's information to registers. (CSFR4*)
- When TOE received Neighbor Solicitation for Local Station, it asserts interrupt and indicates packet's information to registers. (CSFR4*)

30.5.8.1 Auto Response Function for ARP REQ

Table 30.18 is operations for ARP request. See **Figure 30.38** for about the Frame Analysis Flow of ARP REQ.

Table 30.18 Operation after Received ARP REQ

ARP REQ	General Operation		TOE Operation		Remarks Column
	Transmit ARP REPLY	Update Table	REPLY FIFO	REG FIFO	
ARP for Other Station (SourceIP ≠ DestinationIP)	x	x	x	x	ARP REQ for Other Station
ARP for Local Station (SourceIP ≠ DestinationIP)	✓	✓	✓	✓	Operation of ARP for Local Station
GARP for Other Station (SourceIP = DestinationIP)	x	✓	x	✓	Request of updating ARP Table
GARP for Local Station (SourceIP = DestinationIP)	✓	x	✓	x	Response for IP Duplicate Detection

GARP:

REQ which Source IP Address and Destination IP Address are same.

REPLY FIFO:

It stores SourceIP/MAC Address to FIFO and transmits ARP REPLY by Hardware.

The information in this FIFO is cleared after TOE sends ARP REPLY.

REG FIFO:

It stores SourceIP/MAC Address + GARP identification to FIFO and asserts interrupt.

Software is expected to check registers (CSFR4*) and update ARP Table.

The information in this FIFO is cleared by writing "1" to CSRF40.arp_ns. At that time if this FIFO has next information, CSRF40.arp_ns is asserted again and CSFR4* are updated to next information.

Storing to REPLY FIFO and REG FIFO is controlled by followings.

Use followings for Enable/Disable Configuration in a lump.

```
CSFR00.reply_fifo_en
    .reg_fifo_en
```

Use followings for Enable/Disable Configuration of individually

```

CSFR30.arp_self_reply_en
.garp_self_reply_en
.arp_self_int_en
.garp_other_int_en
.garp_self_int_en

```

When CSFR00.arp_ns_abt_en = “1”, the ARP frame which was stored to REPLY FIFO or REG FIFO is not transferred to DMAC. It is discarded (aborted).

REPLY FIFO and REG FIFO is used as shared FIFO for the function of “Auto Response for Neighbor Solicitation” which is indicated in the chapter of 4.8.2. And the FIFO capacity is for 8 frames.

If TOE received ARP REQ when FIFO was full, its information is not stored to FIFO and the interrupt is asserted to notify the status of by reg_fifo_full or reply_fifo_full. If one-FIFO is already full and TOE receives ARP REQ which is stored to both FIFO, its information is not stored to both FIFO.

Table 30.19 Operation after Received Neighbor Solicitation

Neighbor Solicitations	General Operation		TOE Operation		Remarks Column
	Transmit Neighbor Advertisements	Update Cache	REPLY FIFO	REG FIFO	
Multicast for Local Station Option Type = 1 (SourceIP ≠ All 0)	✓	✓	✓	✓	—
Unicast for Local Station Option Type = 1 (SourceIP ≠ All 0)	✓	✓	✓	✓	—
Unicast for Local Station Option Type ≠ 1 or Nothing (SourceIP ≠ All 0)	✓	×	×	✓	Transmission of Neighbor Advertisements is executed by software via REG_FIFO.
IP Duplicate Detection for Local Station Option Type ≠ 1 or Nothing (SourceIP = All 0)	✓	×	✓	×	Response for IP Duplicate Detection
Other	×	×	×	×	Invalid

REPLY FIFO:

It stores SourceIP/MAC Address + multicast/unicast identification to FIFO and transmits Neighbor Advertisements by Hardware.

The information in this FIFO is cleared after TOE sends Neighbor Advertisements.

REG FIFO:

It stores SourceIP/MAC Address + multicast/unicast identification + OptionType to FIFO and asserts interrupt to CPU. Software is expected handling followings by interrupt status (CSFR4*).

- Updating cache.
- In the case of Unicast for Local Station (Option Type ≠ 1 or Nothing), transmits Neighbor Advertisements after checking Source MAC Address by referencing cache or Neighbor search.

The information in this FIFO is cleared by writing “1” to CSRF40.arp_ns. At that time, if this FIFO has next information, CSRF40.arp_ns is asserted again and CSFR4* are updated to next information.

TOE does not support anycast address. If anycast address is set to CSFR02_i register, TOE behaves same action the case of received unicast address. But the Random Delay Function for responding Neighbor Advertisement which is defined in RFC2461 is not supported.

Storing to REPLY FIFO and REG FIFO is controlled by followings.

Use followings for Enable/Disable Configuration in a lump.

CSFR00.reply_fifo_en
.reg_fifo_en

Use followings for Enable/Disable Configuration of individually

CSFR30.ns_mul_reply_en
.ns_uni_reply_en
.ns_dup_reply_en
.ns_mul_int_en
.ns_uni_int_en
.ns_uni_nopt_int_en
.ns_dup_int_en

When CSFR00.arp_ns_abt_en = "1", the Neighbor Solicitation frame which was stored to REPLY FIFO or REG FIFO is not transferred to DMAC. It is discarded (aborted).

REPLY FIFO and REG FIFO is used as shared FIFO for the function of "Auto Response for ARP REQ" which is indicated in the chapter of 4.8.1. And the FIFO capacity is for 8 frames.

If TOE received Neighbor Solicitation when FIFO was full, its information is not stored to FIFO and the interrupt is asserted to notify the status of by reg_fifo_full or reply_fifo_full. If one-FIFO is already full and TOE receives Neighbor Solicitations which is stored to both FIFO, its information is not stored to both FIFO.

30.5.9 Flow Control

Flow control conforming to the IEEE802.3x is possible during full-duplex operation. There are two methods of transmitting PAUSE frames that are used in flow control as given below.

To use this function, configure CCC.FCE and RCR.RFCL of DMAC.

(1) Auto transmission of PAUSE frame (See bit 16 in CXR20)

A PAUSE frame is automatically transmitted by E-MAC when DMAC notifies that the condition of Reception FIFO reached at Critical Level. The value set in the CXR71 parameter settings register is used as the timer value included in the PAUSE frame. After transmitting a PAUSE frame, if the “Reception FIFO Critical Level Notification” from DMAC is not negated by the time that is indicated in the Timer value, the PAUSE frame is sent again. The number of times of transmitting a PAUSE frame can be set from 1 to 65535 in the CXR81 register, and once the upper limit of the transmission count is reached (value set in CXR81), the PAUSE frame is not transmitted thereafter.

However, if the “Reception FIFO Critical Level Notification” from DMAC is negated, the transmission count counter is reset when the next “Reception FIFO Critical Level Notification” from DMAC is asserted and PAUSE frame transmission begins. It is also possible to not define the transmission count upper limit (transmitting for infinite times).

(2) Manual transmission of PAUSE frame (See CXR72)

The PAUSE frame can be transmitted by software instruction. PAUSE frame transmission is started by setting the Timer value in the CXR72 register. In this case, PAUSE frame is transmitted once only (one frame).

(3) PAUSE Timer value (See bits 19 and 20 in CXR20)

Control can be enabled or disabled for the PAUSE frames having PAUSE Timer value 0

a) Operation during transmission

If control is enabled and the “Reception FIFO Critical Level Notification” from DMAC is negated within the time indicated by the Timer value, the PAUSE frame with Timer value 0 is transmitted.

If control is disabled, the PAUSE frame with Timer value 0 is not transmitted.

b) Operation during reception

If control is enabled, a PAUSE frame with Timer value 0 is received and frame transmission waiting is cancelled.

If control is disabled, a PAUSE frame with Timer value 0 is received and the PAUSE frame is discarded.

(4) PAUSE frame reception (See the bit 17 in CXR20)

When a PAUSE frame is received, the next frame transmission is in wait mode till the time which is considered Timer value of PAUSE frame elapses. The transmission of the frame that is being transmitted continues. In addition, the PAUSE frame reception count is counted (See CXR80).

30.5.10 Low Power Idle (LPI)

E-MAC supports the function of Low Power Idle for 1 Gbps/100 Mbps transfer rate. Since LPI function for 10Mbps is not defined in standard*¹, E-MAC also does not support.

Note 1. Specifically, Standard of 10 BASE-T_e whose voltage is lower than 10 BASE-T was defined. But a basic specification except about voltage (such as the rule of Code or Media Access Control Operation) is same as 10 BASE-T. (10 BASE-T_e is supported by the cable of Cat5 or more)

(1) Output function of Low Power Idle Code (LPI Code)

When E-MAC does not receive any transmission request during over certain period, E-MAC outputs transmission LPI Code to PHY for notifying request to change into Low Power Mode. If E-MAC receives a transmission request (not includes the request for PAUSE frame) while outputting transmission LPI Code, E-MAC changes output Code from transmission LPI Code to Normal Idle Code. Then E-MAC resumes to transmit Frames after waiting certain period (WakeUp time of PHY).

The following time is configurable by register.

- The time from E-MAC does not receive any transmission request to E-MAC starts outputting transmission LPI Code.
- The time from E-MAC received transmission request to E-MAC starts outputting Normal Idle Code.

(2) Receive function of Low Power Idle Code (LPI Code)

When PHY receives a changing request into Low Power Mode from Link Partner, PHY starts outputting reception LPI Code to E-MAC. If E-MAC receives reception LPI Code, E-MAC does not send this Code to TOE. E-MAC outputs Normal Status to TOE same as receiving Normal Idle Code.

(3) Stop function of transmission clock (Only RGMII Mode)

When RGMII interface is used, E-MAC can stop the RGMII transmission clock (TXC) during outputting transmission LPI Code. This function is configurable by register. But the case of MII interface is used, to stop MII transmission clock (TX_CLK) which PHY outputs is prohibited.

(4) Handling function for stopping reception clock (Both RGMII and MII Mode)

E-MAC can accept to stop RGMII and MII reception clock (RXC/RX_CLK) while receiving reception LPI Code. To stop RGMII and MII reception clock (RXC/RX_CLK) is configurable by register of PHY. (See the datasheet of PHY)

[Simplified Full Duplex Mode]

E-MAC supports Simplified Full Duplex Mode which is used for Low Power Idle Function.

In the Full Duplex Mode, when E-MAC receives transmission request from Upper Module (such as DMAC), E-MAC starts transmitting frames without care of PHY status.

But in the Simplified Full Duplex Mode, E-MAC cares the PHY status and does not transmit any frames to PHY during both PHY status is Low Power Idle and PHY is changing status from Low Power Idle to Normal.

To use E-MAC as Simplified Full Duplex Mode, set '1' to DMP bit and LPM bit of CXR20 register after checking Link Partner supports Low Power Idle Mode by Auto Negotiation*².

- Note 2.** Check PHY and Link Partner support Low Power Idle Mode before setting E-MAC as Low Power Idle Mode. And for the function of Low Power Idle Mode, registers area of PHY was expanded. Therefore, to use Low Power Idle Mode, software has to be changed for the function of accessing PHY registers, PHY Auto Negotiation and initial setting of E-MAC.

30.5.11 Control of Reference Clock for Ethernet

Gigabit Ethernet Interface IP has a function to notify the status that whether Gigabit Ethernet Interface needs Reference Clock for Ethernet “clk_miitx_gtx_refclk” or not by “ref_clk_stop_en”. And this condition also is notified to CPU by interrupt signal “pif_int_n” (Case of interrupt is indicated on TIS.RCSRFS and ISS.RCSRSM).

This function is only enabled when the configurations of Gigabit Ethernet Interface are matched following all conditions.

- RGMII is selected as PHY IF.
- This function is enabled by register configuration. (CCC.ERCS = 1)
- E-MAC is configured as LowPowerMode. (CXR20.LPM = 1), Duplex = Full and TransmitSpeed = 1000 M/100 Mbps.

Figure 30.42 is a block diagram of this function.

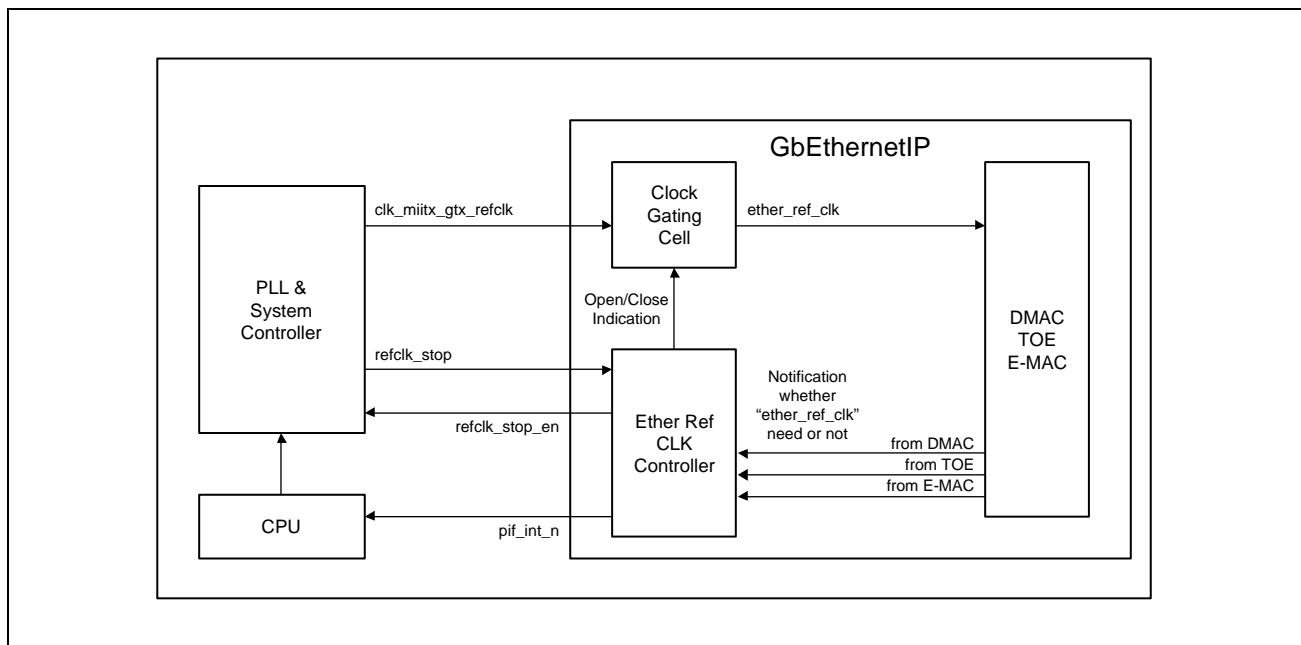

Figure 30.42 Block Diagram

As showing **Figure 30.42**, Gigabit Ethernet Interface has an “Ether Ref CLK Controller” which controls “ref_clk_stop_en”, “pif_int_n” and Open/Close Operation of Internal Clock Gating Cell for “clk_miitx_gtx_refclk”.

The state of Open/Close Operation of Internal Clock Gating Cell is indicated on CSR.RCSI.

NOTE

Whenever “pif_int_n” is asserted by this function, CPU has to instruct PLL & System Controller to stop “clk_miitx_gtx_refclk”.

30.5.11.1 Stop Procedure of Reference Clock for Ethernet

Stop procedure of “clk_miitx_gtx_refclk” is executed by following steps.

1. When DMAC and TOE do not have any Transmission Frames, they do not need “clk_miitx_gtx_refclk” anymore. So, they notify that status to Ether Ref CLK Controller.
2. After outputting Transmission LPI Code during configured time at LPTXG(M)TH4, E-MAC does not need “clk_miitx_gtx_refclk” anymore, So, it notifies that status to Ether Ref CLK Controller.
3. When Ether Ref CLK Controller is received the status that all of DMAC/TOE/E-MAC don't need “clk_miitx_gtx_refclk” any more, it asserts “ref_clk_stop_en” to notify about this condition to ETH_PLL & System Controller. Then Gigabit Ethernet Interface closes an internal Clock Gating Cell for “clk_miitx_gtx_refclk” and asserts “pif_int_n” to indicate this condition to CPU.
4. CPU instructs ETH_PLL & System Controller to stop “clk_miitx_gtx_refclk” and writes “0” to TIS.RCSRFB to clears “pif_int_n”.
5. After PLL is stopped completely, ETH_PLL & System Controller asserts “ref_clk_stop” notifying PLL status to Ether Ref CLK Controller.

Figure 30.43 is a sequence of stopping “clk_miitx_gtx_refclk”.

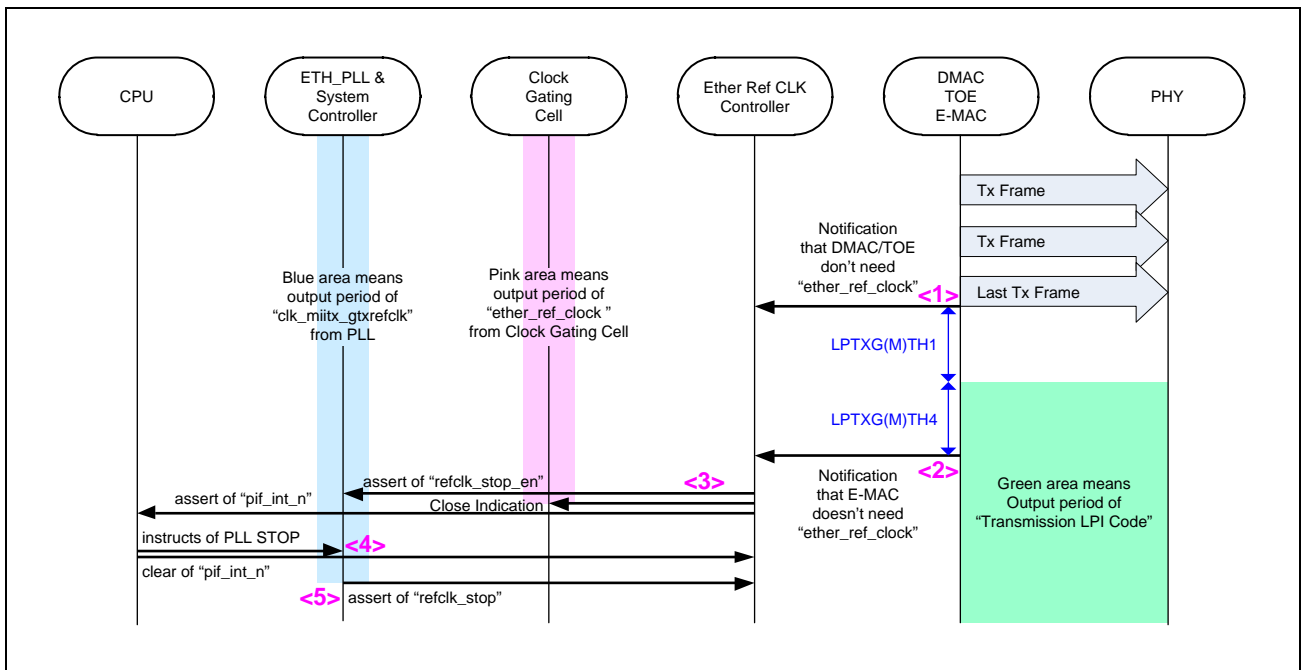

Figure 30.43 Sequence of stopping “clk_miitx_gtx_refclk”

30.5.11.2 Resume Procedure of Reference Clock for Ethernet

Resume procedure of “clk_miitx_gtx_refclk” is executed by following steps.

Case1: Gigabit Ethernet Interface receives indication from CPU restarting transmission operation.

1. CPU indicates restarting transmitting operation to DMAC.
2. DMAC fetches a new transmission descriptor and gets a Transmission Frame from external Memory. Then, it notifies to Ether Ref CLK Controller that it needs “clk_miitx_gtx_refclk” for transmitting operation.
3. After Ether Ref CLK Controller is notified from DMAC that DMAC needs “clk_miitx_gtx_refclk”, it de-asserts “ref_clk_stop_en” to notify ETH_PLL & System Controller that Gigabit Ethernet Interface needs restart of PLL.
4. ETH_PLL & System Controller tries to restart PLL. After “clk_miitx_gtx_refclk” is resumed completely, it de-asserts “ref_clk_stop” to notify Ether Ref CLK Controller about PLL status.
5. By the change of “ref_clk_stop” from assert to de-assert, Ether Ref CLK Controller opens the internal Clock Gating Cell for “clk_miitx_gtx_refclk”.
6. Since providing clock is resumed, Transmitting Function of DMAC/TOE/E-MAC is also resumed. Then, E-MAC outputs a Transmission Frame to PHY after outputting IDLE Code during the time which is configured at LPTXG(M)TH3 register.

Figure 30.44 is a sequence of resuming “clk_miitx_gtx_refclk” of Case1.

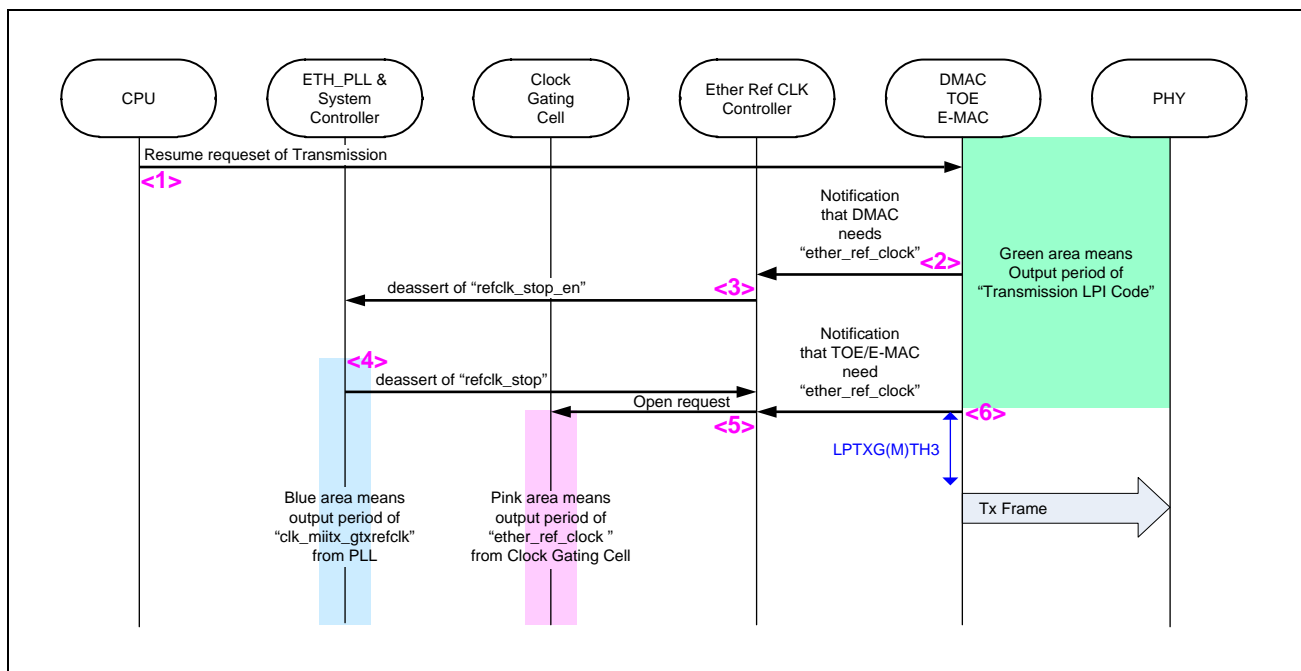

Figure 30.44 Sequence of resuming “clk_miitx_gtx_refclk” of Case1

Case2: Gigabit Ethernet Interface receives a frame which needs to Automatic Response by H/W.

For about the function of Automatic Response by H/W, see 4.8.

1. Received a frame which needs to Automatic Response by H/W from PHY.
2. After received the frame, TOE notifies to Ether Ref CLK Controller that it needs "clk_miitx_gtx_refclk" for transmitting operation.
3. After Ether Ref CLK Controller is notified from TOE that TOE needs "clk_miitx_gtx_refclk", it deasserts "ref_clk_stop_en" to notify ETH_PLL & System Controller that Gigabit Ethernet Interface needs restart of PLL.
4. ETH_PLL & System Controller tries to restart PLL. After "clk_miitx_gtx_refclk" is resumed completely, it deasserts "ref_clk_stop" to notify Ether Ref CLK Controller about PLL status.
5. By the change of "ref_clk_stop" from assert to de-assert, Ether Ref CLK Controller opens the internal Clock Gating Cell for "clk_miitx_gtx_refclk".
6. Since providing clock is resumed, Transmitting Function of DMAC/TOE/E-MAC is also resumed. Then, E-MAC outputs an Automatic Response Frame to PHY after outputting IDLE Code during the time which is configured at LPTXG(M)TH3 register.

Figure 30.45 is a sequence of resuming "clk_miitx_gtx_refclk" of Case2.

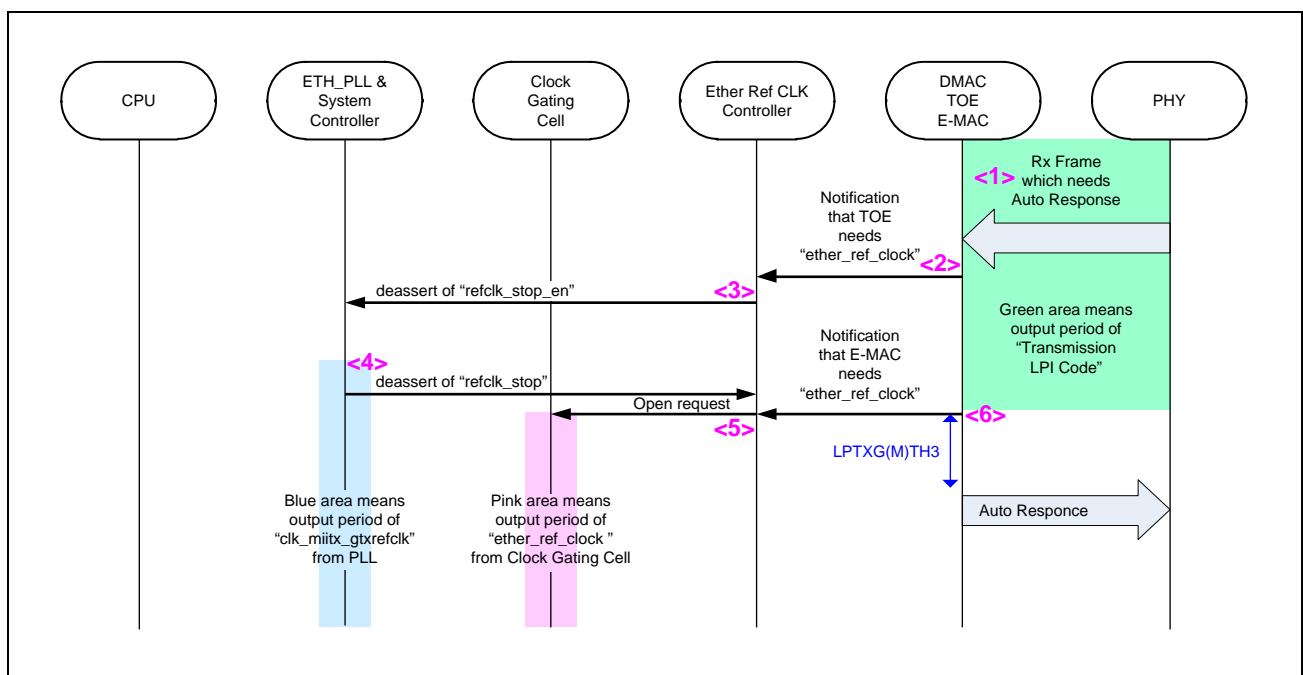

Figure 30.45 Sequence of resuming "clk_miitx_gtx_refclk" of Case2

30.5.12 Interrupts

The DMAC related interrupts include descriptor interrupts, error interrupts, reception interrupts and transmission interrupts. The states of a DMAC-related interrupt sources can be checked in the following registers.

- Descriptor interrupt status register (DIS)
- Error interrupt status register (EIS)
- Receive interrupt status register (RISi)
- Transmit interrupt status register (TIS)

The interrupts are controlled by the corresponding interrupt enable bits. However, the status flags operate independently of the settings of the enable bits.

The states of grouped interrupts can only be checked by reading the interrupt summary status register (ISS) and the queue full error interrupt summary bit in the error interrupt status register (EIS.QFS). This reduces the load on the CPU.

30.5.12.1 Transmit/Receive Data Management Interrupt

The management interrupt for transmission and reception is conveyed when the interrupt conditions corresponding to the following sources are satisfied.

- Receive frame interrupts in the receive interrupt status register 0 (RIS0.FRF)
- Descriptor processed interrupts in the receive interrupt status register 3 (RIS3.RDPF)
- Frame transmitted interrupts in the transmit interrupt status register (TIS.FTF)
- Descriptor processed interrupts in the transmit interrupt status register (TIS.TDPF)
- Descriptor processed interrupts in the descriptor interrupt status register (DIS.DPFi)

The general error interrupt state can be checked by reading the descriptor interrupt flag bits in the interrupt summary status register (ISS.DPMi) or the Reception FIFO warning interrupt summary bit (ISS.RFWM).

30.5.12.2 Error Management Interrupt

The error management interrupt is conveyed when interrupt conditions corresponding to the following sources are satisfied.

- Queue error interrupt in the error interrupt status register (EIS.QEF)
- E-MAC and TOE transmission/reception error interrupts in the error interrupt status register (EIS.MTEF, EIS.MREF, EIS.MFFF, EIS.MFFF2)
- Reception FIFO full interrupt in the receive interrupt status register 2 (RIS2.RFFF)
- Receive queue full interrupts in the receive interrupt status register 2 (RIS2.QFF0)

The general error interrupt state can be checked by reading the error interrupt summary bit in the interrupt summary status register (ISS.EM, ISS.MFWM2, ISS.MFUM2).

30.5.12.3 Other Management Interrupts

The other management interrupt is conveyed when interrupt conditions corresponding to the following sources are satisfied.

(1) Reception related interrupt

- Reception FIFO warning interrupt in the receive interrupt status register 1 (RIS1.RFWF)

(2) Transmission related interrupts

- MAC Status FIFO/FIFO2 Warning Flag (TIS.MFWF/TIS.MFWF2)
- MAC status FIFO/FIFO2 Updated Flag (TIS.MFUF/TIS.MFUF2)
- Reference Clock Stop Req Flag (TIS.RCSRF)

The general error interrupt state can be checked by reading the Reception FIFO warning error interrupt status bit in the interrupt summary status register (ISS.RFWM).

30.5.12.4 E-MAC Interrupt

The E-MAC interrupt is conveyed when the E-MAC interrupt source is generated.

- PAUSE Frame Retry Interrupt in the E-MAC status register (CXR21.PFRI)
- PHY Interrupt in the E-MAC status register (CXR21.PHYI)
- LINK Interrupt in the E-MAC status register (CXR21.LINKI)
- False Carrier Interrupt in the E-MAC status register (CXR21.FCI)

The general error interrupt state can be checked by reading the E-MAC interrupt summary bit in the interrupt summary status register (ISS.MM).

30.5.12.5 TOE Interrupt

The TOE interrupt is issued when the TOE interrupt source is generated.

- Wake Up interrupt in the TOE register (CSFR20)
- ARPREQ/Neighbor Solicitation Receive interrupt in the TOE register (CSFR40, CSFR42_*, CSFR43_*)

30.5.12.6 Interrupt

Table 30.20, **Table 30.21**, and **Table 30.22** shows interrupt for each interrupt status bit. Interrupts of DMAC and E-MAC are merged into the “pif_int_n” of output port. TOE has two independent output ports “int_fil_n” and “int_arp_ns_n”.

Table 30.20 Interrupt of DMAC

Interrupt trigger	Interrupt flag bit	Interrupt enable bit	Interrupt (Output port)
The descriptor in a reception or transmit queue has been processed where DESCR.DIE is i	DIS.DPFI (i = 1 to 15)	DIC.DPEi = 1	pif_int_n
In receive queue a frame is stored, and data is available to be processed by CPU.	RIS0.FRPF	RIC0.FRE = 1	
The descriptor in reception queue has been processed where DESCR.DIE is 0001b.	RIS3.RDPF	RIC3.RDPE = 1 & CIE.CRIE = 1	
The descriptor in transmit queue has been processed where DESCR.DIE is 0001b.	TIS.TDPF	TIC.TDPE = 1 & CIE.CTIE = 1	
A frame is transmitted from transmit queue.	TIS.FTF	TIC.FTE = 1	
An error has been detected while processing receive or transmit queue.	EIS.QEF	EIC.QEE = 1	
The E-MAC has detected a fault during transmission.	EIS.MTEF	EIC.MTEE = 1	
The E-MAC has detected a fault during reception.	EIS.MREF	EIC.MREE = 1	
The MAC status FIFO2 is full.	EIS.MFFF2	EIC.MFFE2 = 1	
The MAC status FIFO is full.	EIS.MFFF	EIC.MFFE = 1	
A received frame was not completely stored in the Reception FIFO.	RIS2.RFFF	RIC2.RFFE = 1	
No sufficient space in receive queue to store completely a received frame.	RIS2.QFF0	RIC2.QFE = 1	
The Reception FIFO has reached warning level.	RIS1.RFWF	RIC1.RFWE = 1	
The MAC status FIFO has been reached warning level.	TIS.MFWF	TIC.MFWE = 1	
The MAC status FIFO has been updated.	TIS.MFUF	TIC.MFUE = 1	
The MAC status FIFO2 has been reached warning level.	TIS.MFWF2	TIC.MFWE2 = 1	
The MAC status FIFO2 has been updated.	TIS.MFUF2	TIC.MFUE2 = 1	
Reference Clock Stop Request has been notified	TIS.RCSRF	TIC.RCSRE = 1	

Table 30.21 Interrupt of E-MAC

Interrupt trigger	Interrupt flag bit	Interrupt enable bit	Interrupt (Output port)
PAUSE Frame Retry reached to threshold.	CXR21.PFRI	CXR22.PFRIM	pif_int_n
PHY Interrupt is detected.	CXR21.PHYI	CXR22.PHYIM	
LINK status change is detected.	CXR21.LINKI	CXR22.LINKIM	
False Carrier is detected.	CXR21.FCI	CXR22.FCIM	

Table 30.22 Interrupt of TOE

Interrupt trigger	Interrupt flag bit	Interrupt mask bit	Interrupt main enable bit	Interrupt (Output port)
Transmit Rx Frame to DMAC	CSFR20.trs_dmac	CSFR21.trs_dmac_m	—	int_fil_n
Reception of IEEE Length Frames.	CSFR20.ieee_len	CSFR21.ieee_len_m	—	
Reception of Invalid Neighbor Solicitations.	CSFR20.ns_dis	CSFR21.ns_dis_m	—	
Reception of IP Duplicate Detection Neighbor Solicitations.	CSFR20.ns_dup	CSFR21.ns_dup_m	—	
Reception of unicast Neighbor Solicitations. (Except "Option Type=1" or No "Option Type")	CSFR20.ns_uni_nopt	CSFR21.ns_uni_nopt_m	—	
Reception of unicast Neighbor Solicitations. ("Option Type=1")	CSFR20.ns_uni	CSFR21.ns_uni_m	—	
Reception of multicast Neighbor Solicitations.	CSFR20.ns_mul	CSFR21.ns_mul_m	—	
Reception of Un-analyzable Frames.	CSFR20.ana_stp	CSFR21.ana_stp_m	—	
Reception of Un-analyzable IPv6 Protocol No.	CSFR20.v6_ana_protocol	CSFR21.v6_ana_protocol_m	—	
Reception of ARP (Except ARP REQ).	CSFR20.arp_noreq	CSFR21.arp_noreq_m	—	
Reception of GARP REQ for Local Station.	CSFR20.garp_self	CSFR21.garp_self_m	—	
Reception of GARP REQ for Other Station.	CSFR20.garp_other	CSFR21.garp_other_m	—	
Reception of ARP REQ for Local Station.	CSFR20.arp_self	CSFR21.arp_self_m	—	
Reception of ARP REQ for Other Station.	CSFR20.arp_other	CSFR21.arp_other_m	—	
Match of IPv6 UDP Port No.	CSFR20.v6_udp_pt	CSFR21.v6_udp_pt_m	—	
Match of IPv4 UDP Port No.	CSFR20.v4_udp_pt	CSFR21.v4_udp_pt_m	—	
Match of IPv6 Protocol No.	CSFR20.v6_protocol	CSFR21.v6_protocol_m	—	
Match of IPv4 Protocol No.	CSFR20.v4_protocol	CSFR21.v4_protocol_m	—	
Match of Ether Type.	CSFR20.type	CSFR21.type_m	—	
Match of Multicast MAC DA.	CSFR20.mac_da_mul	CSFR21.mac_da_mul_m	—	
Match of Broadcast MAC DA.	CSFR20.mac_da_bro	CSFR21.mac_da_bro_m	—	
Match of Unicast MAC DA.	CSFR20.mac_da_uni	CSFR21.mac_da_uni_m	—	
REPLY_FIFO is full.	CSFR40.reply_fifo_full	CSFR41.reply_fifo_full_m	CSFR00.reply_fifo enable & at least one CSFR30.xx_reply_en	int_arp_ns_n
REG_FIFO is full.	CSFR40.reg_fifo_full	CSFR41.reg_fifo_full_m	CSFR00.reg_fifo_en & at least one CSFR30.xx_int_en	
Reception of ARPREQ or Neighbor Solicitations and Stored to REG FIFO.	CSFR40.arp_ns	CSFR41.arp_ns_m	CSFR00.reg_fifo_en & at least one CSFR30.xx_int_en	

30.5.13 Configuration Procedure

The following are Configuration Procedures. The meaning of “X” in Write Value, set the appropriate value to each bit for your system.

30.5.13.1 Set Up Procedure

Check the Configuration of Other Station by using Auto Negotiation Function of PHY before setting Transfer Rate (1 Gbps/100 Mbps/10 Mbps), Duplex Mode (Half or Full), Low Power Mode and Flow Control to E-MAC registers.

Action	Address	Write Value	Description	
Hardware Reset				
↓				
DMAC.CSR	Read	H'00C	—	Check the read value is same as "H'00000001" (Reset Mode).
↓				
DMAC.CCC	Write	H'000	H'00000001	Set "Config Mode"
↓				
DMAC.CSR	Read	H'00C	—	Check the read value is same as "H'00000002" (Config Mode).
↓				
E-MAC Initial Configuration (Not necessary to change other E-MAC registers)				
E-MAC.CXR35	Write	H'540	H'XXXXXXXX	Set the appropriate value for your system. And wait the double of your configuration value to this register.
E-MAC.CXR31	Write	H'530	H'0000000X	Set the appropriate value for your system. (Only if In-Band Status of RGMII will be used)
E-MAC.CXR2C	Write	H'52C	H'0000000X	Set the appropriate value for your system.
E-MAC.CXR2A	Write	H'508	H'00002000	Set Max Frame size as 8KB.
E-MAC.CXR71	Write	H'554	H'0000XXXX	Set the appropriate value for your system. (Only if Flow Control Function will be used)
E-MAC.CXR24	Write	H'5C0	H'XXXXXXXX	Set the appropriate value for your system.
E-MAC.CXR25	Write	H'5C8	H'0000XXXX	Set the appropriate value for your system.
E-MAC.CXR21	Write	H'510	H'0000001F	Clear all Interrupt.
E-MAC.CXR22	Write	H'518	H'0000000X	Set the appropriate value for your system.
E-MAC.CXR2D	Write	H'5B0	H'000000X0	Set the appropriate value for your system. (Only if In-Band Status of RGMII will not be used)
E-MAC.CXR2G	Write	H'5BC	H'0000000X	Set the appropriate value for your system. (Only if Software LINK will not be used)
↓				
TOE Initial Configuration (Not necessary to change other TOE registers).				
TOE.CSR1	Write	H'804	H'0XX000XX	Set the appropriate value for your system.
TOE.CSR2	Write	H'808	H'0XX000XX	Set the appropriate value for your system.
TOE.CSFR01	Write	H'844	H'XXXXXXXX	Set the appropriate value for your system.
TOE.CSFR02_i	Write	H'848+4*i	H'XXXXXXXX	Set the appropriate value for your system. (i = 0 to 3)
TOE.CSFR03_U	Write	H'858	H'0000XXXX	Set the appropriate value for your system.
TOE.CSFR03_L	Write	H'85C	H'XXXXXXXX	Set the appropriate value for your system.
TOE.CSFR10_i	Write	H'870+4*i	H'XXXXXXXX	Set the appropriate value for your system. (i = 0 to 3)
TOE.CSFR10	Write	H'880	H'000000XX	Set the appropriate value for your system.
TOE.CSFR11_i	Write	H'884+4*i	H'XXXXXXXX	Set the appropriate value for your system. (i = 0 to 3)
TOE.CSFR11	Write	H'894	H'0000XXXX	Set the appropriate value for your system.
TOE.CSFR12_i	Write	H'898+4*i	H'XXXXXXXX	Set the appropriate value for your system. (i = 0 to 11)
TOE.CSFR12	Write	H'8C8	H'00XXXXXX	Set the appropriate value for your system.
TOE.CSFR13_U	Write	H'8CC	H'0000XXXX	Set the appropriate value for your system.
TOE.CSFR13_L	Write	H'8D0	H'XXXXXXXX	Set the appropriate value for your system.
TOE.CSFR14_U	Write	H'8D4	H'0000XXXX	Set the appropriate value for your system.
TOE.CSFR14_L	Write	H'8D8	H'XXXXXXXX	Set the appropriate value for your system.
TOE.CSFR15_U_i	Write	H'8DC+8*i	H'0000XXXX	Set the appropriate value for your system. (i = 0 to 19)
TOE.CSFR15_L_i	Write	H'8E0+8*i	H'XXXXXXXX	Set the appropriate value for your system. (i = 0 to 19)
TOE.CSFR15	Write	H'97C	H'XX0XXXXX	Set the appropriate value for your system.
TOE.CSFR20	Write	H'9A0	H'000FFFFF	Clear all Interrupt.
TOE.CSFR21	Write	H'9A4	H'000XXXXX	Set the appropriate value for your system.

Action	Address	Write Value	Description	
TOE.CSFR30	Write	H'9B0	H'000XXXXX	Set the appropriate value for your system.
TOE.CSFR31	Write	H'9B4	H'XX0XXXXX	Set the appropriate value for your system.
TOE.CSFR00	Write	H'840	H'10XXXXXX	Enable the appropriate Filter Function for your system. Disable of Auto Response Function.
↓				
DMAC Initial Configuration (Not necessary to change other DMAC registers).				
DMAC.DBAT	Write	H'004	H'XXXXXXXX	Set the appropriate value for your system.
DMAC.RCR	Write	H'090	H'XXX000X	Set the appropriate value for your system.
DMAC.RTC	Write	H'0B4	H'00002000	Set Max Reception Frame size as 8 KB.
DMAC.CIE	Write	H'384	H'0000X0X	Set the appropriate value for your system.
DMAC.DIE	Write	H'450	H'000XXXXX	Set the appropriate value for your system.
DMAC.EIE	Write	H'458	H'0000X0X	Set the appropriate value for your system.
DMAC.RIE0	Write	H'460	H'000000X	Set the appropriate value for your system.
DMAC.RIE1	Write	H'468	H'X000000	Set the appropriate value for your system.
DMAC.RIE2	Write	H'470	H'X00000X	Set the appropriate value for your system.
DMAC.TIE	Write	H'478	H'000XX0X	Set the appropriate value for your system.
DMAC.RIE3	Write	H'488	H'000000X	Set the appropriate value for your system.
↓				
DMAC.CCC	Write	H'000	H'0X0X0002	Set bit [1:0] = "10b" (Operation Mode) and bit25 (FCE)/bit18 (ERCS) = "the appropriate value for your system".
↓				
TOE.CSR0	Write	H'800	H'00000030	Set TPE and RPE = "1" and TOE FIFO=2 KB.
↓				
E-MAC.CXR20	Write	H'500	H'0XXXXXX H'02030061 H'02030063 H'02030073	Set the appropriate value for your system. (The following are example) Rx CRC PassThrough, PAUSE, TPE and RPE = '1', Half Duplex (for 100 Mbps/10 Mbps), Promiscuous. Rx CRC PassThrough, PAUSE, TPE/RPE = '1', Full Duplex (for 10 Mbps), Promiscuous. Rx CRC PassThrough, PAUSE, TPE/RPE = '1', Simplified Full Duplex (for 1 Gbps/100 Mbps), Promiscuous.
↓				
DMAC.TCCR	Write	H'304	H'000X0001	Set bit0 (TSRQ) = "1" and bit18 (MFEN2), bit16 (MFEN) = "the appropriate value to for your system".

30.5.13.2 System Mode Change Procedure (Normal -> Network Standby)

Action	Address	Write Value	Description	
DMAC.TCCR	Read	H'304	—	Wait until bit0 (TSRQ) will be "0".
↓				
DMAC.CSR	Read	H'00C	—	Wait until bit16 (TPO) and bit20 (RPO) will be "0".
↓				
DMAC.CCC	Write	H'000	H'0X0X0202	Set bit9 (RDFD) = "1" to stop fetch of Rx Descriptor. Not necessary to change other bits.
↓				
DMAC.CSR	Read	H'00C		Wait until bit9 (RDFDM) will be "1" and re-check bit20 (RPO) is "0".*1
↓				
TOE Configuration to enable Auto Response Function (Not necessary to change other registers)				
TOE.CSFR40	Write	H'9C0	H'00000007	Clear all Interrupt.
TOE.CSFR41	Write	H'9C4	H'0000000X	Set the appropriate value for your system.
TOE.CSFR00	Write	H'840	H'1XXXXXXX	Enable of the appropriate Auto Response Function for your system. Not necessary to change Filter Function.
↓				
Change System Mode from "Normal" to "Network Standby".				
↓				
Set Tx Descriptor and Tx Frame at Internal SRAM				
↓				
DMAC.DBAT	Write	H'004	H'XXXXXXXX	Set the appropriate value for your system.
↓				
DMAC.DLR	Write	H'008	H'003FFFFF	Set bit0 and bit4 = "1" loading DBAT to Tx and Rx queue.
↓				

Action	Address	Write Value	Description
DMAC.TCCR	Write H'304	H'000X0001	Set bit0 (TSRQ) = "1" and bit18 (MFEN2), bit16 (MFEN) = "the appropriate value to for your system".

Note 1. If bit9 (RDFDM) is "0" and bit20 (RPO) is "0", wait bit9 (RDFDM) will be "1" without accessing other registers.
 If bit9 (RDFDM) is "1" and bit20 (RPO) is "0", the DMA transfer and fetch of Rx Descriptor have stopped.
 So go to next step.
 If bit9 (RDFDM) is "0" and bit20 (RPO) is "1", wait bit9 (RDFDM) will be "1" without accessing other registers.
 If bit9 (RDFDM) is "1" and bit20 (RPO) is "1", the Reception Frame was stored to Reception FIFO.
 So software has to cancel changing System mode. Set DMAC.CCC. bit9 (RDFD) = "0" immediately to resume fetch of Rx Descriptor.

30.5.13.3 System Mode Change Procedure (Network Standby -> Normal)

Action	Address	Write Value	Description
TOE.CSFR00	Write H'840	H'10XXXXXX	Disable of the Auto Response Function. Not necessary to change Filter Function.
↓			
DMAC.TCCR	Read H'304	—	Wait until bit0 (TSRQ) will be "0".
↓			
DMAC.CSR	Read H'00C	—	Wait until bit16 (TPO) will be "0".
↓			
Change System Mode from "Network Standby" to "Normal".			
↓			
Set Rx/Tx Descriptor and Tx Frame at External SDRAM.			
↓			
DMAC.DBAT	Write H'004	H'XXXXXXXX	Set the appropriate value for your system.
↓			
DMAC.DLR	Write H'008	H'003FFFFF	load DBAT to Tx and Rx queue.
↓			
DMAC.CCC	Write H'000	H'0X0X0002	Set "bit9 (RDFD) = 0" to start Rx DMA Transfer for Rx Frame. Not necessary to change other bits.
↓			
DMAC.TCCR	Write H'304	H'000X0001	Set bit0 (TSRQ) = "1" and bit18 (MFEN2), bit16 (MFEN) = "the appropriate value to for your system".

30.5.13.4 Stop Procedure

Action	Address	Write Value	Description	
Make "EOS" in the Tx Descriptor chain and wait until it is used. (Wait the interrupt of DIS.DPFI of this EOS Descriptor.)				
↓				
E-MAC.CXR20	Write	H'500	H'0XXXXXXX	Set bit6 (RPE) = "0" to stop Rx Function of E-MAC. Not necessary to change other bits.
↓				
Wait following time depending on the Transfer speed mode. (Waiting time that the last Rx Frame is stored to Reception FIFO and the last Tx Frame is transmitted to PHY)				
• 1 Gbps : Wait 70 μs • 100 Mbps : Wait 700 μs • 10 Mbps : Wait 7 ms				
↓				
DMAC.CSR	Read	H'00C	—	Wait until bit20 (RPO) will be "0" (Wait Reception FIFO will be empty)
↓				
DMAC.CCC	Write	H'000	H'0X0X0102	Set bit8 (DTSR) = "1" to stop URAM access. Not necessary to change other bits.
↓				
DMAC.CSR	Read	H'00C	—	Wait until bit8 (DTS) will be "1" (URAM access is stopping)
↓				
TOE.CSR0	Write	H'800	H'00000000	Set bit5 (RPE) = "0" and bit4 (TPE) = "0" to stop Rx and Tx Function of TOE. Not necessary to change other bits.
↓				
TOE.CSR0	Read	H'800	—	Wait until bit5 (RPE) and bit4 (TPE) will be "0"
↓				
E-MAC.CXR20	Write	H'500	H'0XXXXXXX	Set bit5 (TPE) = "0" to stop Tx Function of E-MAC. Not necessary to change other bits.
↓				
E-MAC.CXR20	Read	H'500	—	Wait until bit6 (RPE) and bit5 (TPE) will be "0"
↓				
DMAC.CCC	Write	H'000	H'0X0X0001	Set bit [1:0] = "01b" (Config Mode) and bit8 (DTSR) = "0"

Note: If the system needs software reset, set DMAC.CCC bit [1:0] = "00b" to be RESET Mode after "Stop Procedure" and retry "Set up Procedure".

30.5.14 Connection to PHY-LSI

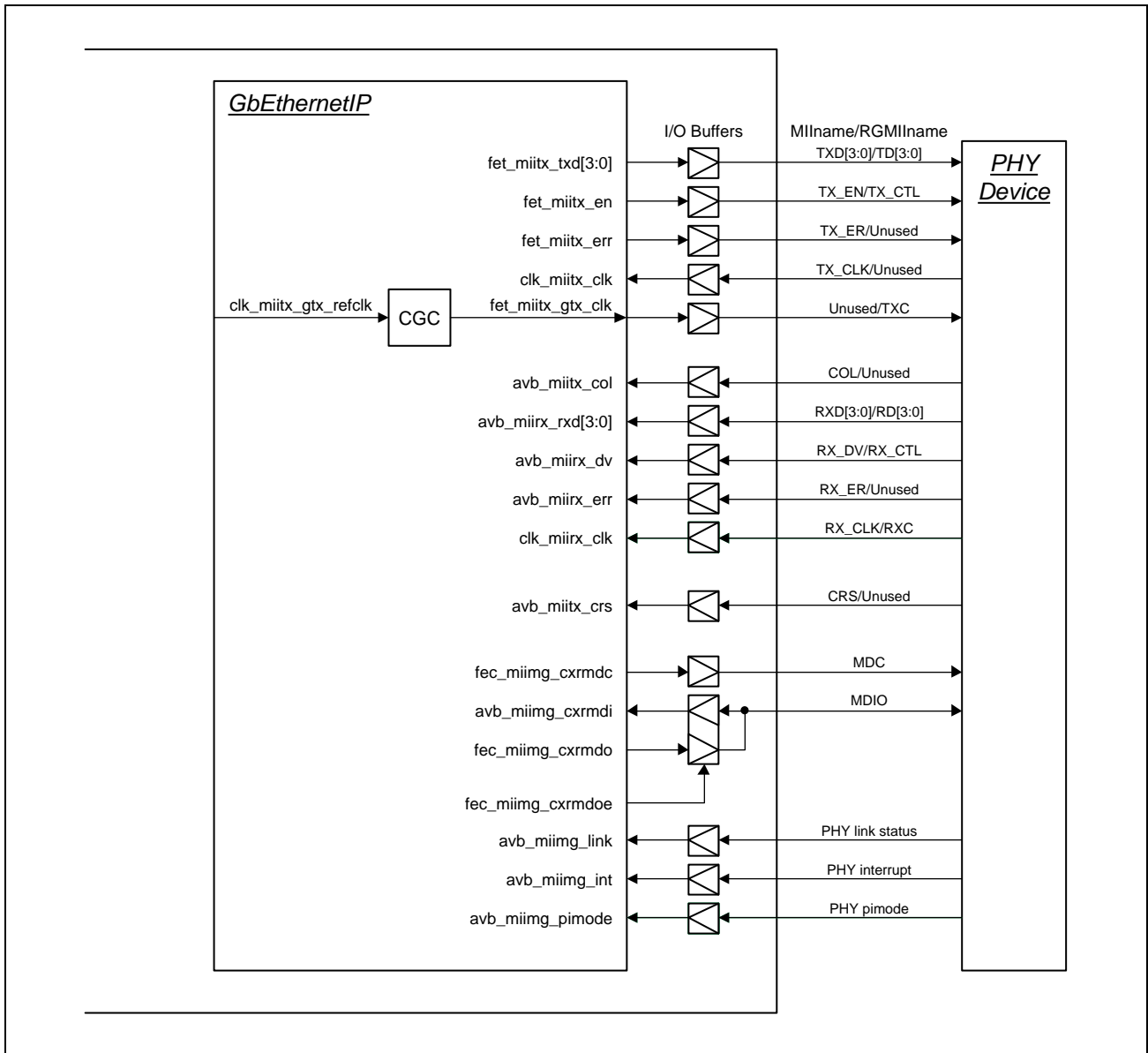

Figure 30.46 Connection to PHY-LSI

30.5.14.1 RGMII Frame Transmission/Reception Timing

Each RGMII frame transmission/reception timing is shown in **Figure 30.47** and **Figure 30.48**.

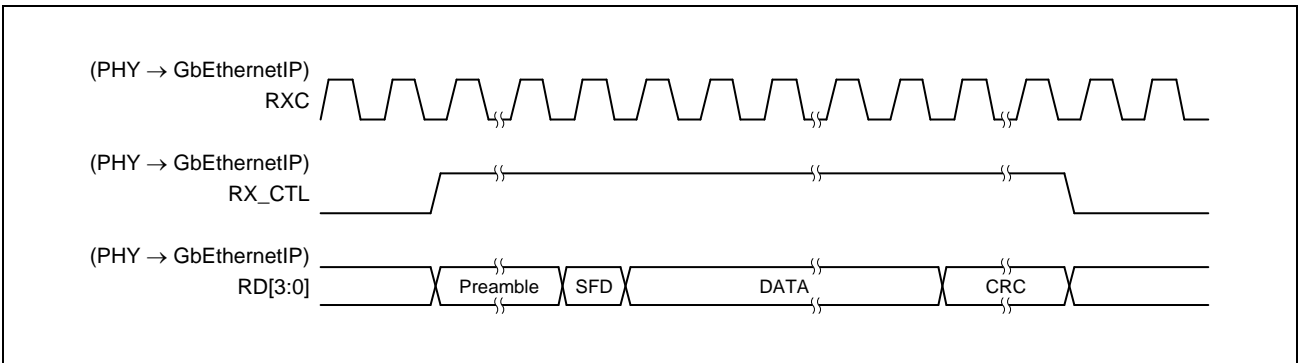

Figure 30.47 Normal Frame Reception Time Chart (RGMII)

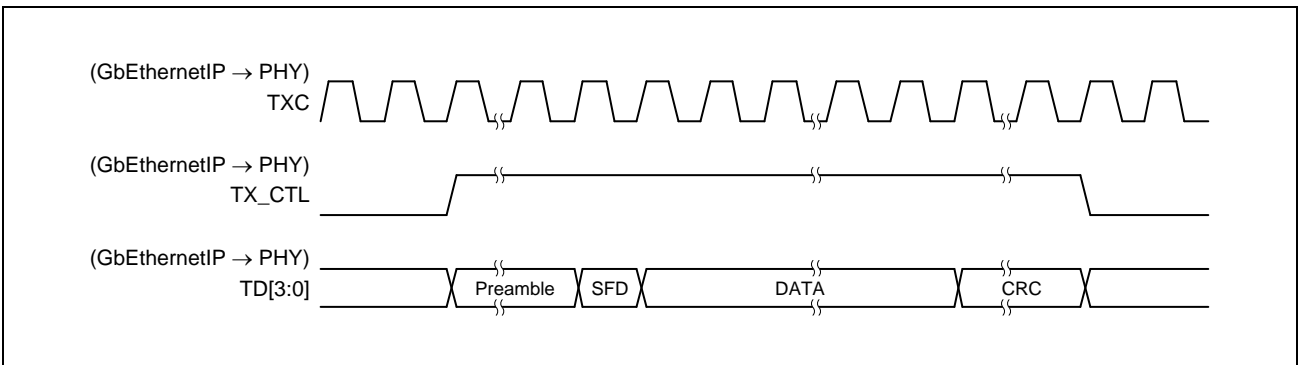

Figure 30.48 Normal Frame Transmission Time Chart (RGMII)

30.5.14.2 MII Frame Reception Timing

Each MII frame transmission/reception timing is shown in **Figure 30.49** and **Figure 30.50**.

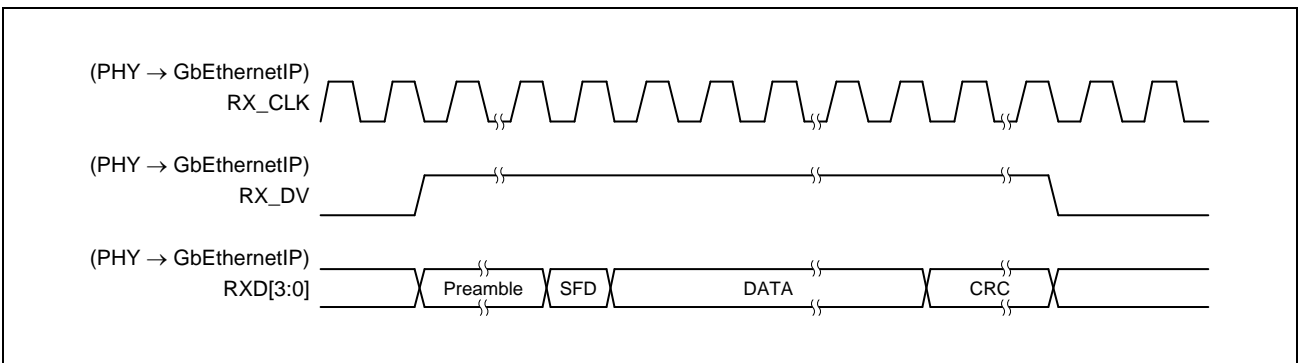

Figure 30.49 Normal Frame Reception Time Chart (MII)

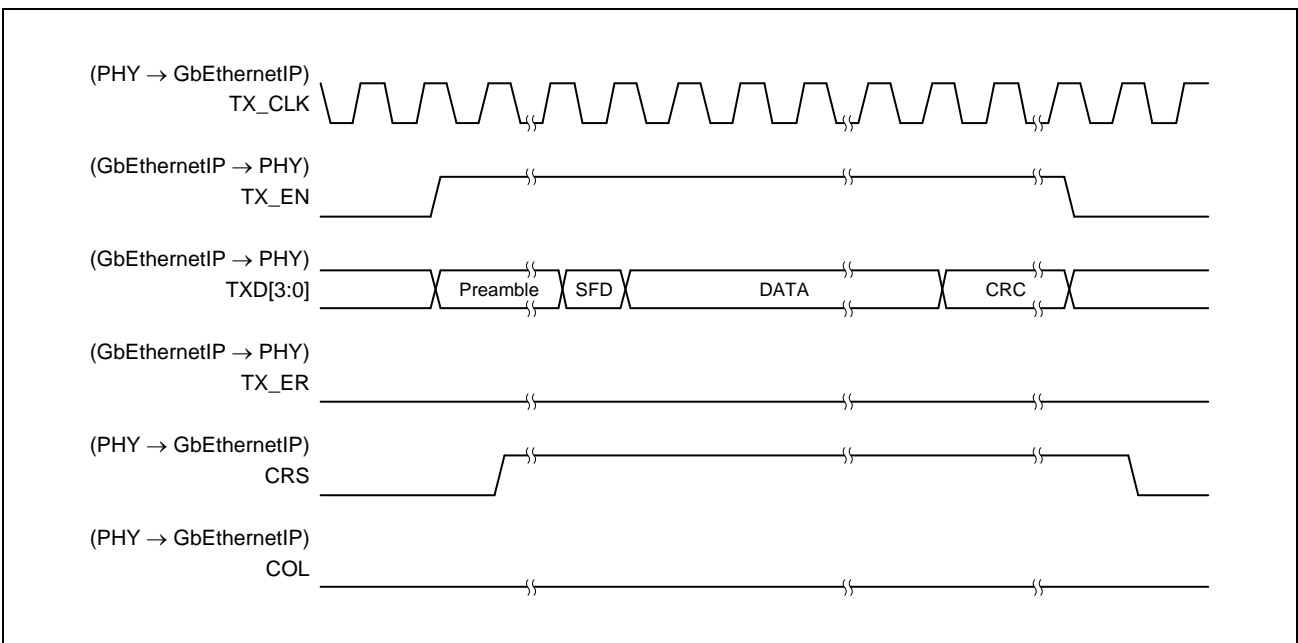

Figure 30.50 Normal Frame Transmission Time Chart (MII)

30.5.14.3 Accessing PHY Registers

There are two methods to access the PHY register: using the E-MAC-MDIOC block and using the CXR23 register.

Which access method to be used can be set using the MDIOMOD register.

(1) PHY Register Access Method (using MDIOC)

To access the PHY register from MDIOC, the SEL_MDIO bit in MDIOMOD register must be set to 0.

The following commands can be used for indirect access using MDIOC.

Table 30.23 List of MDIOC Commands

Command	OP code	Address	Data	Description
WRITE	"01"	A [9:0]	D [15:0]	Write PHY register
READ	"10"	A [9:0]	D [15:0]	Read PHY register

PHY Register Write Access Procedure (Using MDIOC)

The write access procedure for PHY register is given below.

- (1) Read MDIOSTS register and confirm that BSY bit = 0.
- (2) Set PHY address as (A [9:5]) and register address as (A [4:0]) in MDIOADR register.
- (3) Set write data in MDIODAT register.
- (4) Set OP field of MDIOCMD register to "01".
{Here, the hardware sets BSY bit in MDIOSTS register to 1.}
- (5) Read MDIOSTS register and wait till BSY bit = 0. After BSY becomes 0, write access is complete.
{After write access to PHY register completes, the BSY bit in MDIOSTS register is cleared to 0 by hardware.}

PHY Register Read Access Procedure (Using MDIOC)

The read access procedure for PHY Register is given below.

- (1) Read MDIOSTS register and confirm that BSY bit = 0.
- (2) Set PHY address as (A [9:5]) and register address as (A [4:0]) in MDIOADR register.
- (3) Set OP field of MDIOCMD register to "10".
{Here, the hardware sets BSY bit in MDIOSTS register to 1.}
- (4) Read MDIOSTS register and wait till BSY bit = 0.
{After read access from PHY register completes and read data becomes available in MDIODAT register, hardware clears BSY bit in MDIOSTS register is cleared to 0 by hardware.}
- (5) When the BSY bit in MDIOSTS register is cleared to 0, read data is acquired from MDIODAT register and access is complete.

(2) PHY Register Access Method (Using CXR23)

To access PHY register using CXR23 register, SEL_MDIO bit of MDIOMOD register must be set to 1. (The initial value can be used as is.)

PHY access using CXR23 is done by controlling High and Low of MDC and MDIO signals for every cycle. The relationship between CXR23 register access and MDC and MDIO signals is shown below.

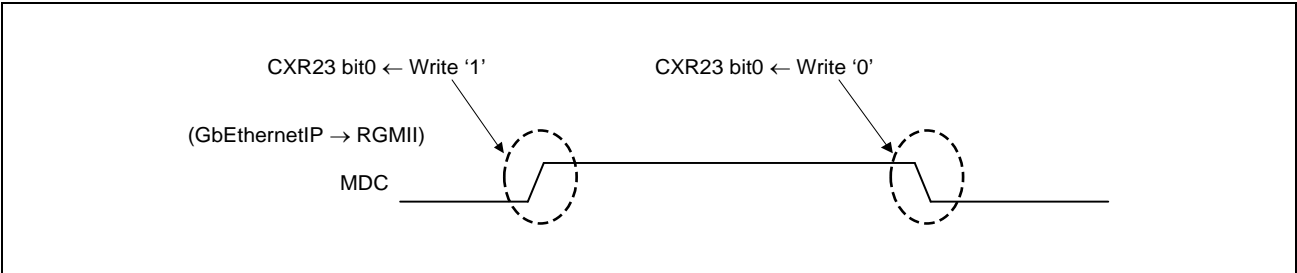

Figure 30.51 Relationship between CXR23 Write and MDC signal

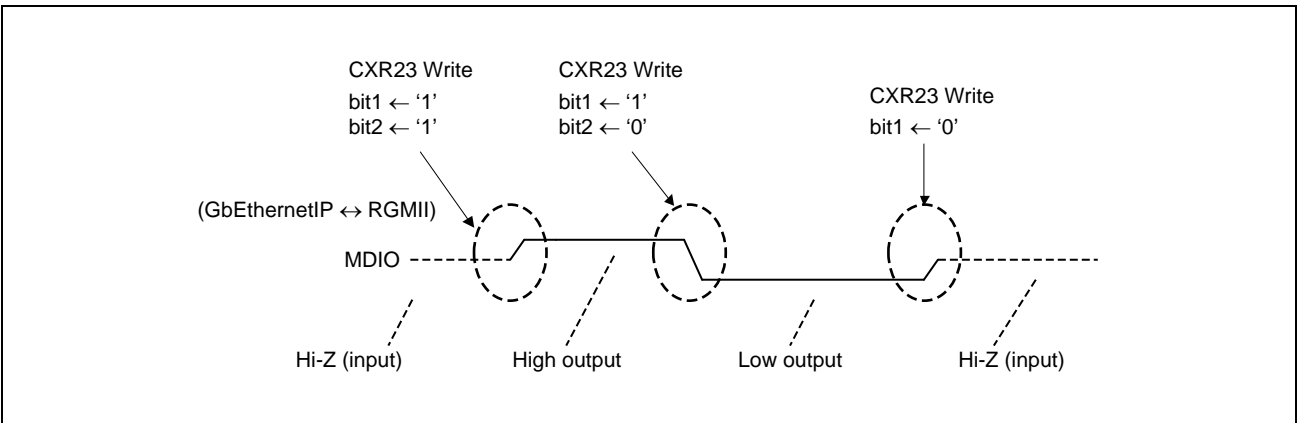

Figure 30.52 Relationship between CXR23 Write and MDIO (output) signal

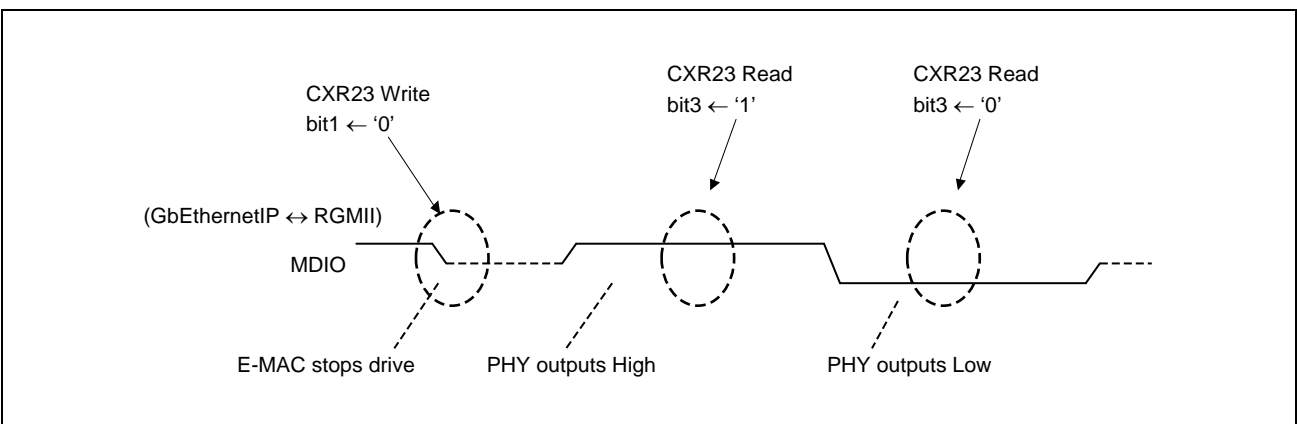

Figure 30.53 Relationship between MDIO input and CXR23 Read Values

PHY Register Write Access Procedure (Using CXR23)

To write PHY chip register, control MDC and MDIO signals based on the format given below.

(1) PHY Write Access Format

Table 30.24 PHY Write Access Format

#	Field name	I/O	Details	Remarks
1	Preamble	Output	1 = 32 bits	Preamble
2	ST	Output	"01"	Start
3	Op Code (Write)	Output	"01"	Operation code for write
4	PHY Address	Output	5 bit	PHY address (See data sheet of PHY LSI)
5	Reg Address	Output	5 bit	Register address (See data sheet of PHY LSI)
6	Turn Around	Output	"10"	Turnaround
7	Data (Write)	Output	16 bit	Write data
8	IDLE	—	—	Idle status

(2) PHY Register Write Access Time chart

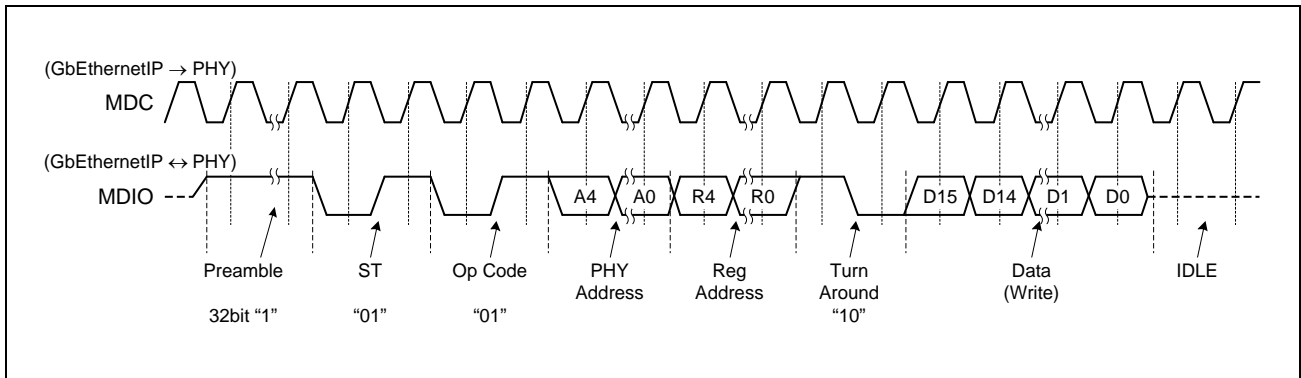

Figure 30.54 PHY Register Write Access Time Chart

(3) PHY Register Write Access Procedure

Table 30.25 PHY Register Write Access Procedure (1/2)

#	CXR23				CXR23 access	Description
	bit 3	bit 2	bit 1	bit 0		
0	0	0	0	0	Initial state	IDLE
1	0	1	1	1	CXR23 WRITE	Start of Write access (MDC rise)
2	0	1	1	0	CXR23 WRITE	(MDC fall)
3	0	1	1	1	CXR23 WRITE	Preamble1
4	0	1	1	0	CXR23 WRITE	
5	0	1	1	1	CXR23 WRITE	Preamble2
6	0	1	1	0	CXR23 WRITE	
7	0	1	1	1	CXR23 WRITE	Preamble3
8	0	1	1	0	CXR23 WRITE	
—	—	—	—	—	—	Repeat
64	0	1	1	0	CXR23 WRITE	
65	0	1	1	1	CXR23 WRITE	Preamble32
66	0	0	1	0	CXR23 WRITE	
67	0	0	1	1	CXR23 WRITE	ST
68	0	1	1	0	CXR23 WRITE	
69	0	1	1	1	CXR23 WRITE	ST
70	0	0	1	0	CXR23 WRITE	
71	0	0	1	1	CXR23 WRITE	Op Code (Write)
72	0	1	1	0	CXR23 WRITE	
73	0	1	1	1	CXR23 WRITE	Op Code (Write)
74	0	A4	1	0	CXR23 WRITE	PHY address A4 bit is output here
75	0	A4	1	1	CXR23 WRITE	PHY Address
76	0	A3	1	0	CXR23 WRITE	
77	0	A3	1	1	CXR23 WRITE	PHY Address
78	0	A2	1	0	CXR23 WRITE	
79	0	A2	1	1	CXR23 WRITE	PHY Address

Table 30.25 PHY Register Write Access Procedure (2/2)

#	CXR23				CXR23 access	Description
	bit 3	bit 2	bit 1	bit 0		
80	0	A1	1	0	CXR23 WRITE	
81	0	A1	1	1	CXR23 WRITE	PHY Address
82	0	A0	1	0	CXR23 WRITE	
83	0	A0	1	1	CXR23 WRITE	PHY Address
84	0	R4	1	0	CXR23 WRITE	REG address A4 bit is output here
85	0	R4	1	1	CXR23 WRITE	REG Address
86	0	R3	1	0	CXR23 WRITE	
87	0	R3	1	1	CXR23 WRITE	REG Address
88	0	R2	1	0	CXR23 WRITE	
89	0	R2	1	1	CXR23 WRITE	REG Address
90	0	R1	1	0	CXR23 WRITE	
91	0	R1	1	1	CXR23 WRITE	REG Address
92	0	R0	1	0	CXR23 WRITE	
93	0	R0	1	1	CXR23 WRITE	REG Address
94	0	1	1	0	CXR23 WRITE	Turn Around
95	0	1	1	1	CXR23 WRITE	Turn Around
96	0	0	1	0	CXR23 WRITE	Turn Around
97	0	0	1	1	CXR23 WRITE	Turn Around
98	0	D15	1	0	CXR23 WRITE	Write data D15 bit is output here
99	0	D15	1	1	CXR23 WRITE	Write Data
100	0	D14	1	0	CXR23 WRITE	
101	0	D14	1	1	CXR23 WRITE	Write Data
—	—	—	—	—	—	Repeat
112	0	D1	1	0	CXR23 WRITE	
113	0	D1	1	1	CXR23 WRITE	Write Data
114	0	D0	1	0	CXR23 WRITE	
115	0	D0	1	1	CXR23 WRITE	Write Data
116	0	0	0	0	CXR23 WRITE	IDLE
117	0	0	0	1	CXR23 WRITE	IDLE
118	0	0	0	0	CXR23 WRITE	IDLE
119	0	0	0	1	CXR23 WRITE	IDLE
120	0	0	0	0	CXR23 WRITE	IDLE
121	0	0	0	1	CXR23 WRITE	IDLE
122	0	0	0	0	CXR23 WRITE	IDLE End of write access

PHY Register Read Access Procedure (Using CXR23)

To read from the PHY chip registers, control MDC and MDIO signals in the format given below

(1) PHY Read Access Format

Table 30.26 PHY Read Access Format

#	Field name	I/O	Details	Remarks
1	Preamble	Output	1 = 32 bits	Preamble
2	ST	Output	"01"	Start
3	Op Code (read)	Output	"10"	Operation code for read
4	PHY Address	Output	5 bit	PHY address (See data sheet of PHY LSI)
5	Reg Address	Output	5 bit	Register address (See data sheet of PHY LSI)
6	Turn Around	Input	"Z0"	Turnaround (input/output switching)
7	Data (Read)	Input	16 bit	Read data
8	IDLE	—	—	Idle state

(2) PHY Register Read Access Time Chart

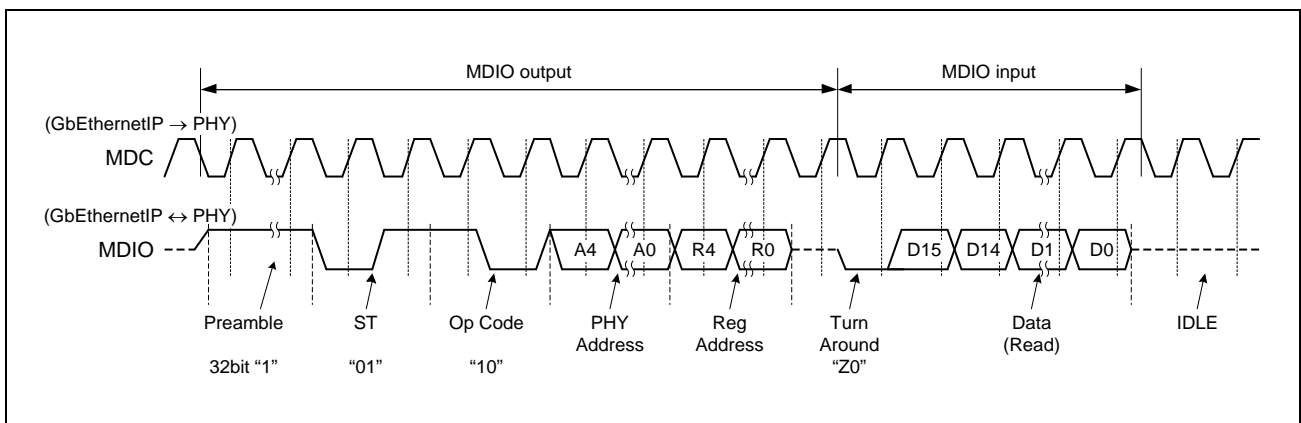

Figure 30.55 PHY Register Read Access Time Chart

(3) PHY Register Read Access Procedure

Table 30.27 PHY Register Read Access Procedure (1/2)

#	CXR23				CXR23 access	Description
	bit 3	bit 2	bit 1	bit 0		
0	0	0	0	0	Initial state	IDLE
1	0	1	1	1	CXR23 WRITE	Start of write access (MDC rise)
2	0	1	1	0	CXR23 WRITE	(MDC fall)
3	0	1	1	1	CXR23 WRITE	Preamble1
4	0	1	1	0	CXR23 WRITE	
5	0	1	1	1	CXR23 WRITE	Preamble2
6	0	1	1	0	CXR23 WRITE	
7	0	1	1	1	CXR23 WRITE	Preamble3
8	0	1	1	0	CXR23 WRITE	
—	—	—	—	—	—	Repeat
64	0	1	1	0	CXR23 WRITE	
65	0	1	1	1	CXR23 WRITE	Preamble32
66	0	0	1	0	CXR23 WRITE	
67	0	0	1	1	CXR23 WRITE	ST
68	0	1	1	0	CXR23 WRITE	
69	0	1	1	1	CXR23 WRITE	ST
70	0	1	1	0	CXR23 WRITE	
71	0	1	1	1	CXR23 WRITE	Op Code (Read)
72	0	0	1	0	CXR23 WRITE	
73	0	0	1	1	CXR23 WRITE	Op Code (Read)
74	0	A4	1	0	CXR23 WRITE	PHY address A4 bit is output here
75	0	A4	1	1	CXR23 WRITE	PHY Address
76	0	A3	1	0	CXR23 WRITE	
77	0	A3	1	1	CXR23 WRITE	PHY Address
78	0	A2	1	0	CXR23 WRITE	
79	0	A2	1	1	CXR23 WRITE	PHY Address
80	0	A1	1	0	CXR23 WRITE	
81	0	A1	1	1	CXR23 WRITE	PHY Address
82	0	A0	1	0	CXR23 WRITE	
83	0	A0	1	1	CXR23 WRITE	PHY Address
84	0	R4	1	0	CXR23 WRITE	REG address A4 bit is output here
85	0	R4	1	1	CXR23 WRITE	REG Address
86	0	R3	1	0	CXR23 WRITE	
87	0	R3	1	1	CXR23 WRITE	REG Address
88	0	R2	1	0	CXR23 WRITE	
89	0	R2	1	1	CXR23 WRITE	REG Address
90	0	R1	1	0	CXR23 WRITE	
91	0	R1	1	1	CXR23 WRITE	REG Address
92	0	R0	1	0	CXR23 WRITE	
93	0	R0	1	1	CXR23 WRITE	REG Address
94	0	0	0	0	CXR23 WRITE	Turn Around (MDIO Hi-Z Output MDIO Output -> Input)

Table 30.27 PHY Register Read Access Procedure (2/2)

#	CXR23				CXR23 access	Description
	bit 3	bit 2	bit 1	bit 0		
95	0	0	0	1	CXR23 WRITE	Turn Around
96	0	0	0	0	CXR23 WRITE	Turn Around
97	0	0	0	1	CXR23 WRITE	Turn Around
98	0	0	0	0	CXR23 WRITE	Read Data Start
99	D15	X	X	X	CXR23 Read	Here Data bit15 in PHY register can be seen in bit3 in CXR23
100	0	0	0	1	CXR23 WRITE	
101	0	0	0	0	CXR23 WRITE	
102	D14	X	X	X	CXR23 Read	Data bit14 read
103	0	0	0	1	CXR23 WRITE	
104	0	0	0	0	CXR23 WRITE	
—	—	—	—	—	—	Repeat
141	D1	X	X	X	CXR23 Read	Data bit1 read
142	0	0	0	1	CXR23 WRITE	
143	0	0	0	0	CXR23 WRITE	
144	D1	X	X	X	CXR23 Read	Data bit0 read
145	0	0	0	1	CXR23 WRITE	Read Data End
146	0	0	0	0	CXR23 WRITE	IDLE
147	0	0	0	1	CXR23 WRITE	IDLE
148	0	0	0	0	CXR23 WRITE	IDLE
149	0	0	0	1	CXR23 WRITE	IDLE
150	0	0	0	0	CXR23 WRITE	IDLE
151	0	0	0	1	CXR23 WRITE	IDLE
152	0	0	0	0	CXR23 WRITE	IDLE End of read access

31. A/D Converter

31.1 Features

This LSI has a successive approximation A/D converter with a 12-bit accuracy. Up to two analog input channels can be selected.

■ Resolution

12 bits

■ Two input channels

■ Input voltage range

0 V to 1.8 V

■ Minimum conversion time

1.0 μ s per channel (when A/D conversion clock ADIVCLK is 20 MHz)

■ Four data registers

The A/D conversion result is stored in a 32-bit data register corresponding to each channel.

■ Sample-and-hold function

■ Trigger mode

- Software trigger mode and hardware trigger mode are available.
- Software trigger mode to start A/D conversion by software
- Hardware trigger mode to start A/D conversion by an asynchronous trigger or synchronous trigger
 - Asynchronous trigger using an external pin (ADC_TRG) as the activation source
 - Synchronous trigger using the multi-function timer pulse unit 3 (MTU3a) or general-purpose

■ Operating mode

- Select mode and scan mode are available.
- Select mode to convert the specified single analog input channel
 - 1-buffer mode or 4-buffer mode can be specified for storing the A/D conversion result.
 - In 4-buffer mode, A/D conversion proceeds four times for the selected analog input and the A/D conversion results are stored in four registers.
- Scan mode to convert the analog inputs of arbitrarily selected channels in ascending order of channel number
 - 1-buffer mode can be specified for storing the A/D conversion result.

■ Conversion mode

- Single mode and repeat mode are available.
- Single mode to proceed A/D conversion only once
- Repeat mode to repeatedly proceed A/D conversion

■ A single interrupt source

- An A/D conversion end interrupt (INTAD) can be generated on completion of A/D conversion.
 - In the select mode with 1-buffer mode selected, an A/D conversion end interrupt is generated on completion of a single conversion.
 - In the select mode with 4-buffer mode selected, an A/D conversion end interrupt is generated on completion of four rounds of conversion.
 - In scan mode, an A/D conversion end interrupt is generated on completion of scanning of all the selected channels.

Table 31.1 shows the outline of the functions of the A/D converter.

Table 31.1 Functions of A/D Converter

Item			Source	
Analog Input Channel			ADC_CH0, ADC_CH1	
Conditions for starting A/D conversion	Software	Software trigger	(Enabled by software)	
	Asynchronous trigger	External trigger*1	Trigger input pin ADC_TRG	
	Synchronous trigger	Trigger from MTU3a	Compare match with or input capture to MTU0.TGRA	TRGA0N
			Compare match with or input capture to MTU1.TGRA	TRGA1N
			Compare match with or input capture to MTU2.TGRA	TRGA2N
			Compare match with or input capture to MTU3.TGRA	TRGA3N
			Compare match with or input capture to MTU4.TGRA or underflow of MTU4.TCNT in complementary PWM mode	TRGA4N
			Compare match with or input capture to MTU6.TGRA	TRGA6N
			Compare match with or input capture to MTU7.TGRA or underflow of MTU7.TCNT in complementary PWM mode	TRGA7N
			Compare match with MTU0.TGRE	TRG0N
			Compare match between MTU4.TADCORA and MTU4.TCNT	TRG4AN
			Compare match between MTU4.TADCORB and MTU4.TCNT	TRG4BN
			Compare match between MTU4.TADCORA and MTU4.TCNT or compare match between MTU4.TADCORB and MTU4.TCNT	TRG4AN or TRG4BN
			Compare match between MTU4.TADCORA and MTU4.TCNT and compare match between MTU4.TADCORB and MTU4.TCNT (when interrupt skipping function 2 is used)	TRG4ABN
			Compare match between MTU7.TADCORA and MTU7.TCNT	TRG7AN
			Compare match between MTU7.TADCORB and MTU7.TCNT	TRG7BN
			Compare match between MTU7.TADCORA and MTU7.TCNT or compare match between MTU7.TADCORB and MTU7.TCNT compare match	TRG7AN or TRG7BN
Compare match between MTU7.TADCORA and MTU7.TCNT and compare match between MTU7.TADCORB and MTU7.TCNT (when interrupt skipping function 2 is used)	TRG7ABN			
Interrupt			INTAD	

Note 1. To set ADC_TRG as the trigger for starting A/D conversion, set the general-purpose I/O function. For details, see **Section 41, General Purpose Input Output Port**.

Table 31.2 lists the I/O pins used in the A/D converter.

Table 31.2 I/O Pins of A/D Converter

Pin Name	I/O	Name	Function
ADC_CH0, ADC_CH1	Input	Analog input pins	Analog input pins
ADC_TRG	Input	A/D conversion trigger input	External trigger input pin for starting A/D conversion
ADC_AVDD18	Input	Analog power supply voltage	A/D converter power supply pin
VSS	Input	Analog ground	A/D converter ground pin

31.2 List of Registers

Table 31.3 shows the register list of this module.

The base address is as follows.

Base address: H'0_1005_9000 (AX45MP Address Space)

Table 31.3 List of Registers of A/D Converter

Register Name	Abbreviation	R/W	Initial Value	Address	Access Size
A/D converter mode register 0	ADM0	R/W	H'0000	H'0	32
A/D converter mode register 1	ADM1	R/W	H'0000	H'4	32
A/D converter mode register 2	ADM2	R/W	H'0000	H'8	32
A/D converter mode register 3	ADM3	R/W	H'0000	H'C	32
Reserved	—	R	H'0000	H'10 – 1F	32
A/D converter interrupt control register	ADINT	R/W	H'0000	H'20	32
A/D converter status register	ADSTS	R/W	H'0000	H'24	32
A/D converter clock division setting register	ADIVC	R/W	H'0000	H'28	32
A/D converter external trigger pin filter control register	ADFIL	R/W	H'0000	H'2C	32
A/D conversion result register 0	ADCR0	R	H'0000	H'30	32
A/D conversion result register 1	ADCR1	R	H'0000	H'34	32
A/D conversion result register 2	ADCR2	R	H'0000	H'38	32
A/D conversion result register 3	ADCR3	R	H'0000	H'3C	32
Reserved	—	R	H'0000	H'40 – 6C	32
Renesas reserved area*1	—	R/W	Undefined	H'70 – 7F	32

Note: When writing successively to the same register, the notes in **Section 31.5.2, Timing Restrictions**, need to be observed.

Note 1. Writing to a Renesas reserved area is prohibited.

31.3 Register Descriptions

31.3.1 A/D Converter Mode Register 0 (ADM0)

The ADM0 is a 32-bit register that controls A/D conversion and the power-saving mode of the A/D converter, and also executes a software reset. This register can be read from and written to in 32-bit units.

Bit	31	30	29	28	27	26	25	24	23	22	21	20	19	18	17	16
	—	—	—	—	—	—	—	—	—	—	—	—	—	—	—	—
Initial Value	0	0	0	0	0	0	0	0	0	0	0	0	0	0	0	0
R/W	R	R	R	R	R	R	R	R	R	R	R	R	R	R	R	R
Bit	15	14	13	12	11	10	9	8	7	6	5	4	3	2	1	0
	SRESB	—	—	—	—	—	—	—	—	—	—	—	—	PWDW NB	ADBSY	ADCE
Initial Value	0	0	0	0	0	0	0	0	0	0	0	0	0	0	0	0
R/W	R/W	R	R	R	R	R	R	R	R	R	R	R	R	R/W	R	R/W

Bit	Bit Name	Initial Value	R/W	Description
31 to 16	—	All 0	R	Reserved When read, the initial value is read. The written value will be ignored.
15	SRESB	0	R/W	Issues a software reset to the A/D converter. Circuits (e.g. registers) other than those of the A/D converter will not be reset. To release the A/D converter from the reset state, write 1 to this bit. 0: A/D converter is reset. 1: A/D converter is released from the reset state. The A/D converter enters the power-saving mode when this bit is used to execute a reset.
14 to 3	—	All 0	R	Reserved When read, the initial value is read. The written value will be ignored.
2	PWDWNB	0	R/W	Specifies the A/D converter to enter or exit the power-saving mode. 0: Power-saving mode 1: Normal mode
1	ADBSY	0	R	Indicates the status of the A/D converter. This bit is read-only. Writing to this bit is ignored. 0: A/D converter is stopped. 1: A/D converter is busy. For operation of the ADBSY bit, see Figure 31.1 .
0	ADCE	0	R/W	Stops or enables the A/D converter. 0: A/D converter is stopped. 1: A/D converter is enabled. When 0 is written to the ADCE bit, the A/D converter stops operating. For operation of the ADCE bit at reading, see Figure 31.1 .

Note: Notes regarding the ADM0 register are given on the next page.

NOTES

1. To enable A/D conversion operation using the ADCE bit, first switch from PWDWNB = 0 (power-saving mode) to PWDWNB = 1 (normal mode) and then wait for a period equal to or longer than the stabilization wait time before setting the ADCE bit to 1. The stabilization wait time is 1 μ s.
2. To make a transition to the power-saving mode using the PWDWNB bit, first stop operation of the A/D converter (ADCE = 0) and then confirm that A/D conversion is completed (ADBSY = 0) before setting the PWDWNB bit to 0.

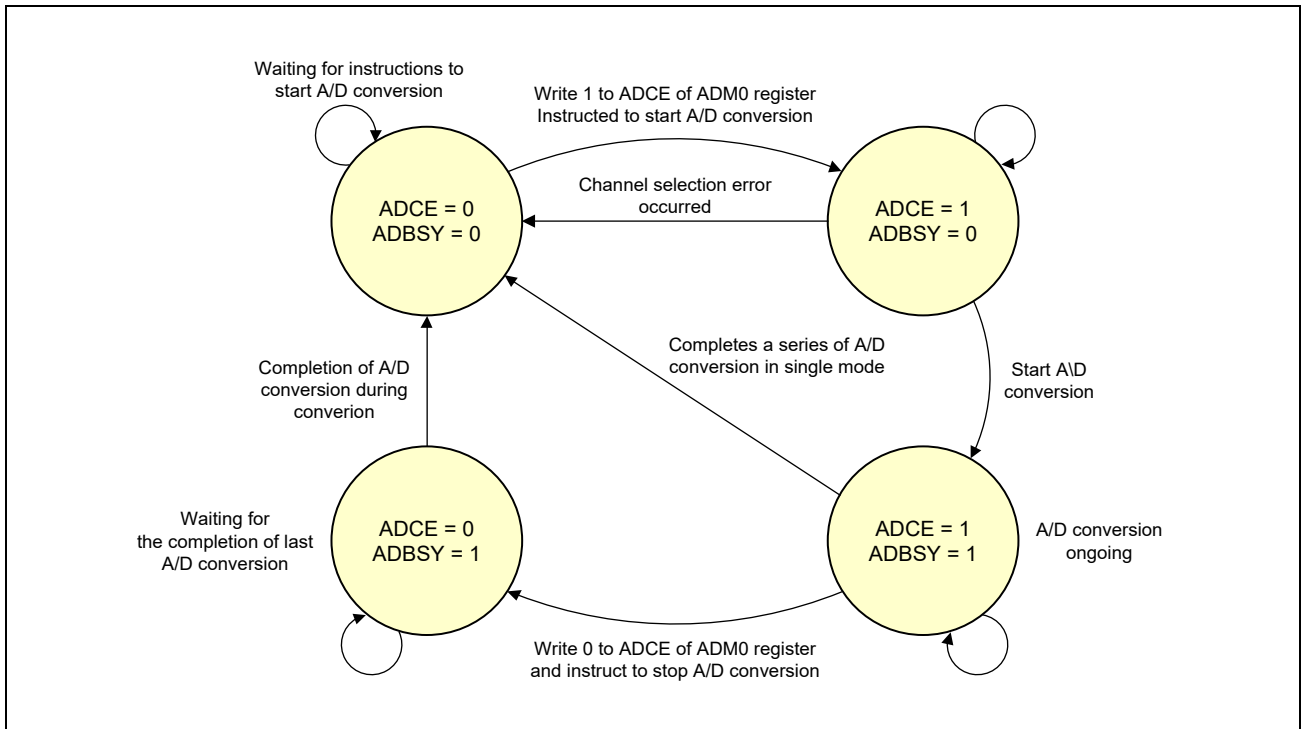

Figure 31.1 State Transitions of ADCE Bit and ADBSY Bit

31.3.2 A/D Converter Mode Register 1 (ADM1)

The ADM1 is a 32-bit register that controls A/D conversion and sets the mode for a hardware trigger. This register can be read from and written to in 32-bit units.

Bit	31	30	29	28	27	26	25	24	23	22	21	20	19	18	17	16
	—	—	—	—	—	—	—	—	—	—	TRGEN 5	TRGEN 4	TRGEN 3	TRGEN 2	TRGEN 1	TRGEN 0
Initial Value	0	0	0	0	0	0	0	0	0	0	0	0	0	0	0	0
R/W	R	R	R	R	R	R	R	R	R	R	R	R	R	R	R	R
Bit	15	14	13	12	11	10	9	8	7	6	5	4	3	2	1	0
	—	—	EGA1	EGA0	—	—	—	—	—	—	—	BS	RPS	MS	TRGIN	TRG
Initial Value	0	0	0	0	0	0	0	0	0	0	0	0	0	0	0	0
R/W	R	R	R/W	R/W	R	R	R	R	R	R	R	R/W	R/W	R/W	R/W	R/W

Bit	Bit Name	Initial Value	R/W	Description															
31 to 22	—	All 0	R	Reserved When read, the initial value is read. The written value will be ignored.															
21 to 16	TRGEN[5:0]	All 0	R/W	These bits select the hardware trigger pin. For details, see Table 31.4 .															
15, 14	—	All 0	R	Reserved When read, the initial value is read. The written value will be ignored.															
13, 12	EGA[1:0]	00	R/W	These bits select the valid edge of the trigger pin. <table border="1"> <thead> <tr> <th>EGA1</th><th>EGA0</th><th>Valid Edge</th></tr> </thead> <tbody> <tr> <td>0</td><td>0</td><td>Hardware trigger is invalid</td></tr> <tr> <td>0</td><td>1</td><td>Falling edge</td></tr> <tr> <td>1</td><td>0</td><td>Rising edge</td></tr> <tr> <td>1</td><td>1</td><td>Both edges</td></tr> </tbody> </table>	EGA1	EGA0	Valid Edge	0	0	Hardware trigger is invalid	0	1	Falling edge	1	0	Rising edge	1	1	Both edges
EGA1	EGA0	Valid Edge																	
0	0	Hardware trigger is invalid																	
0	1	Falling edge																	
1	0	Rising edge																	
1	1	Both edges																	
11 to 5	—	All 0	R	Reserved When read, the initial value is read. The written value will be ignored.															
4	BS	0	R/W	Selects the buffer mode (valid in select mode). 0: 1-buffer mode 1: 4-buffer mode 4-buffer mode is prohibited in scan mode.															
3	RPS	0	R/W	Selects the repeat number. 0: Single 1: Repeat															
2	MS	0	R/W	Selects the operating mode. 0: Scan mode 1: Select mode															
1	TRGIN	0	R/W	Selects the trigger input mode. 0: Auto mode 1: Step mode															

Bit	Bit Name	Initial Value	R/W	Description
0	TRG	0	R/W	Sets the trigger mode. 0: Software trigger mode*1 1: Hardware trigger mode

Note 1. Set the EGA[1:0] bits to 00 when using software trigger mode.

Table 31.4 TRGEN[5:0] Bits and Trigger Source

Module	Source	Description	TRGEN[5:0] Bits					
			5	4	3	2	1	0
External pin	ADC_TRG	External trigger input	0	0	0	0	0	0
MTU	TRGA0N	Compare match with or input capture to MTU0.TGRA	0	0	0	0	0	1
	TRGA1N	Compare match with or input capture to MTU1.TGRA	0	0	0	0	1	0
	TRGA2N	Compare match with or input capture to MTU2.TGRA	0	0	0	0	1	1
	TRGA3N	Compare match with or input capture to MTU3.TGRA	0	0	0	1	0	0
	TRGA4N	Compare match with or input capture to MTU4.TGRA or underflow (trough) of MTU4.TCNT in complementary PWM mode	0	0	0	1	0	1
	TRGA6N	Compare match with or input capture to MTU6.TGRA	0	0	0	1	1	0
	TRGA7N	Compare match with or input capture to MTU7.TGRA or underflow (trough) of MTU7.TCNT in complementary PWM mode	0	0	0	1	1	1
	TRG0N	Compare match with MTU0.TGRE	0	0	1	0	0	0
	TRG4AN	Compare match between MTU4.TADCORA and MTU4.TCNT	0	0	1	0	0	1
	TRG4BN	Compare match between MTU4.TADCORB and MTU4.TCNT	0	0	1	0	1	0
	TRG4AN or TRG4BN	Compare match between MTU4.TADCORA and MTU4.TCNT or compare match between MTU4.TADCORB and MTU4.TCNT	0	0	1	0	1	1
	TRG4ABN	Compare match between MTU4.TADCORA and MTU4.TCNT and compare match between MTU4.TADCORB and MTU4.TCNT (when interrupt skipping function 2 is used)	0	0	1	1	0	0
	TRG7AN	Compare match between MTU7.TADCORA and MTU7.TCNT	0	0	1	1	0	1
	TRG7BN	Compare match between MTU7.TADCORB and MTU7.TCNT	0	0	1	1	1	0
TRG7AN or TRG7BN	Compare match between MTU7.TADCORA and MTU7.TCNT or compare match between MTU7.TADCORB and MTU7.TCNT	0	0	1	1	1	1	
TRG7ABN	Compare match between MTU7.TADCORA and MTU7.TCNT and compare match between MTU7.TADCORB and MTU7.TCNT (when interrupt skipping function 2 is used)	0	1	0	0	0	0	

31.3.3 A/D Converter Mode Register 2 (ADM2)

The ADM2 is a 32-bit register that specifies the analog input channels to be used in A/D conversion. This register can be read from and written to in 32-bit units.

Bit	31	30	29	28	27	26	25	24	23	22	21	20	19	18	17	16
	—	—	—	—	—	—	—	—	—	—	—	—	—	—	—	—
Initial Value	0	0	0	0	0	0	0	0	0	0	0	0	0	0	0	0
R/W	R	R	R	R	R	R	R	R	R	R	R	R	R	R	R	R
Bit	15	14	13	12	11	10	9	8	7	6	5	4	3	2	1	0
	—	—	—	—	—	—	—	—	—	—	—	—	—	—	CHSEL 1	CHSEL 0
Initial Value	0	0	0	0	0	0	0	0	0	0	0	0	0	0	0	0
R/W	R	R	R	R	R	R	R	R	R	R	R	R	R	R	R/W	R/W

Bit	Bit Name	Initial Value	R/W	Description
31 to 8	—	All 0	R	Reserved When read, the initial value is read. The written value will be ignored.
7 to 2	—	All 0	R	Reserved When read, the initial value is read. When writing, be sure to write the initial value. Operation is not guaranteed if a value other than the initial value is written.
1, 0	CHSEL[1:0]	All 0	R/W	These bits select the A/D analog input channel n (n = 0, 1). 0: Analog input channel n is not subjected to conversion. 1: Analog input channel n is subjected to conversion.

Note 1. Select only one channel in select mode.

Note 2. If more than one channel is selected in select mode, a channel select error occurs.

31.3.4 A/D Converter Mode Register 3 (ADM3)

The ADM3 is a 32-bit register that sets the sampling period of the A/D converter. Be sure to set this register before starting the A/D converter. This register can be read from and written to in 32-bit units.

Bit	31	30	29	28	27	26	25	24	23	22	21	20	19	18	17	16
	ADIL7	ADIL6	ADIL5	ADIL4	ADIL3	ADIL2	ADIL1	ADIL0	ADCMP7	ADCMP6	ADCMP5	ADCMP4	ADCMP3	ADCMP2	ADCMP1	ADCMP0
Initial Value	0	0	0	0	0	0	0	0	0	0	0	0	0	0	0	0
R/W	R/W	R/W	R/W	R/W	R/W	R/W	R/W	R/W	R/W	R/W	R/W	R/W	R/W	R/W	R/W	R/W

Bit	15	14	13	12	11	10	9	8	7	6	5	4	3	2	1	0
	ADSMP15	ADSMP14	ADSMP13	ADSMP12	ADSMP11	ADSMP10	ADSMP9	ADSMP8	ADSMP7	ADSMP6	ADSMP5	ADSMP4	ADSMP3	ADSMP2	ADSMP1	ADSMP0
Initial Value	0	0	0	0	0	0	0	0	0	0	0	0	0	0	0	0
R/W	R/W	R/W	R/W	R/W	R/W	R/W	R/W	R/W	R/W	R/W	R/W	R/W	R/W	R/W	R/W	R/W

Bit	Bit Name	Initial Value	R/W	Description
31 to 24	ADIL[7:0]	All 0	R/W	These bits should be set to H'00.
23 to 16	ADCMP[7:0]	All 0	R/W	These bits should be set to H'0E.
15 to 0	ADSMP[15:0]	All 0	R/W	These bits set the sampling period (unit: ADIVCLK cycle). A value from H'06 (6 T) to H'AF0 (2800 T) can be set. T stands for the cycle of ADIVCLK (20 MHz).

Note: The ADIL[7:0] bits should be set to H'00 and the ADCMP[7:0] bits should be set to H'0E. If they are set to other values, normal operation cannot be guaranteed.

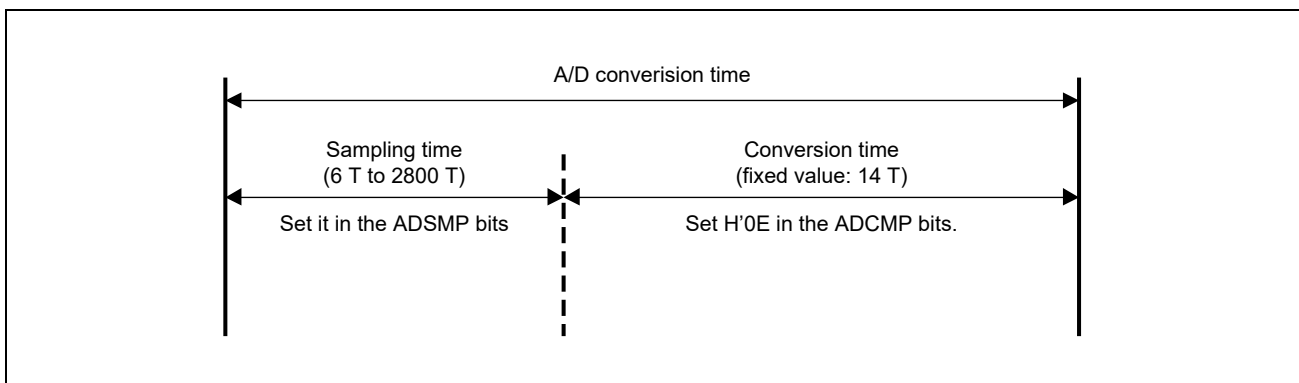

Figure 31.2 Correspondence between ADM3 Register and A/D Conversion Time

NOTE

ADIVCLK is a clock obtained by dividing the frequency of ADC_ADCLK(TSU ϕ) with the ADIVC register setting.

31.3.5 A/D Converter Interrupt Control Register (ADINT)

The ADINT is a 32-bit register that controls interrupts. This register can be read from and written to in 32-bit units.

Bit	31	30	29	28	27	26	25	24	23	22	21	20	19	18	17	16
	INTS	—	—	—	—	—	—	—	—	—	—	—	—	—	—	CSEEN
Initial Value	0	0	0	0	0	0	0	0	0	0	0	0	0	0	0	0
R/W	R	R	R	R	R	R	R	R	R	R	R	R	R	R	R	R/W
Bit	15	14	13	12	11	10	9	8	7	6	5	4	3	2	1	0
	—	—	—	—	—	—	—	—	—	—	—	—	INTEN3	INTEN2	INTEN1	INTEN0
Initial Value	0	0	0	0	0	0	0	0	0	0	0	0	0	0	0	0
R/W	R	R	R	R	R	R	R	R	R	R	R	R	R/W	R/W	R/W	R/W

Bit	Bit Name	Initial Value	R/W	Description
31	INTS	0	R/W	Selects the attribute of the interrupt (INTAD) signal. 0: Pulse signal 1: Reserved This bit should be set to 0.
30 to 17	—	All 0	R	Reserved When read, the initial value is read. The written value will be ignored.
16	CSEEN	0	R/W	Enables or disables the A/D conversion channel select error interrupt. 0: Interrupt output is disabled. 1: Interrupt output is enabled.
15 to 8	—	All 0	R	Reserved When read, the initial value is read. The written value will be ignored.
7 to 4	—	All 0	R	Reserved When read, the initial value is read. When writing, be sure to write the initial value. Operation is not guaranteed if a value other than the initial value is written.
3 to 0	INTEN[3:0]	All 0	R/W	These bits enable or disable the conversion end interrupt of channel n (n = 0 to 3). 0: Interrupt output is disabled. 1: Interrupt output is enabled. INTEN3-2 is used only in 4-buffer mode.

The interrupt signal is specified as a pulse and that pulse is output at any of the following timing:

1. An A/D conversion request is detected while the ADM2 register has caused an A/D conversion channel select error
2. Completion of conversion on the channel for which interrupt output has been enabled in the ADINT register
3. An A/D conversion request is detected while 4-buffer mode has been specified in scan mode

31.3.6 A/D Converter Status Register (ADSTS)

The ADSTS is a 32-bit register that controls the state of the A/D converter. This register can be read from and written to in 32-bit units.

Bit	31	30	29	28	27	26	25	24	23	22	21	20	19	18	17	16
	TRGS	—	—	—	—	—	—	—	—	—	—	—	—	—	—	CSEST
Initial Value	0	0	0	0	0	0	0	0	0	0	0	0	0	0	0	0
R/W	R/W	R	R	R	R	R	R	R	R	R	R	R	R	R	R	R/W
Bit	15	14	13	12	11	10	9	8	7	6	5	4	3	2	1	0
	—	—	—	—	—	—	—	—	—	—	—	—	INTST3	INTST2	INTST1	INTST0
Initial Value	0	0	0	0	0	0	0	0	0	0	0	0	0	0	0	0
R/W	R	R	R	R	R	R	R	R	R	R	R	R	R/W	R/W	R/W	R/W

Bit	Bit Name	Initial Value	R/W	Description
31	TRGS	0	R/W	<ul style="list-style-type: none"> When reading <ul style="list-style-type: none"> 0: Nothing detected 1: A trigger was detected during the A/D conversion time in Figure 31.2. When writing <ul style="list-style-type: none"> 0: No effect 1: The state is cleared.
30 to 17	—	All 0	R	Reserved When read, the initial value is read. The written value will be ignored.
16	CSEST	0	R/W	Indicates the status of the A/D conversion channel select error interrupt. It is the status of the interrupt for an error that occurs when A/D conversion is started with no channel being specified in the CHSEL[1:0] bits in the ADM2 register as a channel on which A/D conversion proceeds. <ul style="list-style-type: none"> When reading <ul style="list-style-type: none"> 0: No A/D conversion channel select error occurred. 1: An A/D conversion channel select error occurred. When writing <ul style="list-style-type: none"> 0: No effect 1: The status is cleared.
15 to 4	—	All 0	R	Reserved When read, the initial value is read. The written value will be ignored.
3 to 0	INTST[3:0]	All 0	R/W	Indicates the state of the conversion end interrupt of channel n (n = 0 to 3). <ul style="list-style-type: none"> When reading <ul style="list-style-type: none"> 0: Conversion has not finished. 1: Conversion has finished. When writing <ul style="list-style-type: none"> 0: No effect 1: The state is cleared.*1

Note 1. When an interrupt source is generated simultaneously with clearing of the interrupt source, clearing is ignored and the respective bit remains set to 1.

31.3.7 A/D Converter Clock Division Setting Register (ADIVC)

The ADIVC is a 32-bit register that sets the frequency division ratio for dividing the frequency of ADC_ADCLK(TSU ϕ) and supplying a clock to the A/D converter. ADIVCLK is a clock obtained by dividing the frequency of ADC_ADCLK(TSU ϕ).

This register can be read from and written to in 32-bit units.

Bit	31	30	29	28	27	26	25	24	23	22	21	20	19	18	17	16
	—	—	—	—	—	—	—	—	—	—	—	—	—	—	—	—
Initial Value	0	0	0	0	0	0	0	0	0	0	0	0	0	0	0	0
R/W	R	R	R	R	R	R	R	R	R	R	R	R	R	R	R	R
Bit	15	14	13	12	11	10	9	8	7	6	5	4	3	2	1	0
	—	—	—	—	—	—	—	DIVADC 8	DIVADC 7	DIVADC 6	DIVADC 5	DIVADC 4	DIVADC 3	DIVADC 2	DIVADC 1	DIVADC 0
Initial Value	0	0	0	0	0	0	0	0	0	0	0	0	0	0	0	0
R/W	R	R	R	R	R	R	R	R/W	R/W	R/W	R/W	R/W	R/W	R/W	R/W	R/W

Bit	Bit Name	Initial Value	R/W	Description
31 to 9	—	All 0	R	Reserved When read, the initial value is read. The written value will be ignored.
8 to 0	DIVADC[8:0]	All 0	R/W	These bits set the frequency division ratio. Only division by 4 can be set, and any other setting is prohibited. 00000100: Division by 4

31.3.8 A/D Converter External Trigger Pin Filter Control Register (ADFIL)

Bit	31	30	29	28	27	26	25	24	23	22	21	20	19	18	17	16
	—	—	—	—	—	—	—	—	—	—	—	—	—	—	—	—
Initial Value	0	0	0	0	0	0	0	0	0	0	0	0	0	0	0	0
R/W	R	R	R	R	R	R	R	R	R	R	R	R	R	R	R	R
Bit	15	14	13	12	11	10	9	8	7	6	5	4	3	2	1	0
	—	—	—	—	—	—	—	—	—	—	FILNUM		—	—	—	FILONOFF
Initial Value	0	0	0	0	0	0	0	0	0	0	0	0	0	0	0	0
R/W	R	R	R	R	R	R	R	R	R	R	R/W	R/W	R	R	R	R/W

Bit	Bit Name	Initial Value	R/W	Description
31 to 6	—	All 0	R	Reserved When read, the initial value is read. The written value will be ignored.
5, 4	FILNUM[1:0]	00	R/W	These bits select the number of stages of the AD external trigger pin filter. The signal to be filtered is ADC_ADCLK(TSU ϕ) (80 MHz). 00: 12.5 ns (80 MHz) \times 4 stages 01: 12.5 ns (80 MHz) \times 8 stages 10: 12.5 ns (80 MHz) \times 12 stages 11: 12.5 ns (80 MHz) \times 16 stages
3 to 1	—	All 0	R	Reserved When read, the initial value is read. The written value will be ignored.
0	FILONOFF	0	R/W	Enables or disables the AD external trigger pin filter 0: Filter is disabled. 1: Filter is enabled.

31.3.9 A/D Conversion Result Registers 3 to 0 (ADCR3 to ADCR0)

The ADCR3 to ADCR0 are 32-bit registers that hold the A/D conversion results. The A/D converter has four 32-bit registers. These registers are read from in 32-bit units.

Bit	31	30	29	28	27	26	25	24	23	22	21	20	19	18	17	16
	—	—	—	—	—	—	—	—	—	—	—	—	—	—	—	—
Initial Value	0	0	0	0	0	0	0	0	0	0	0	0	0	0	0	0
R/W	R	R	R	R	R	R	R	R	R	R	R	R	R	R	R	R
Bit	15	14	13	12	11	10	9	8	7	6	5	4	3	2	1	0
	—	—	—	—	AD11	AD10	AD9	AD8	AD7	AD6	AD5	AD4	AD3	AD2	AD1	AD0
Initial Value	0	0	0	0	0	0	0	0	0	0	0	0	0	0	0	0
R/W	R	R	R	R	R	R	R	R	R	R	R	R	R	R	R	R

Bit	Bit Name	Initial Value	R/W	Description															
31 to 12	—	All 0	R	Reserved When read, the initial value is read. The written value will be ignored.															
11 to 0	AD[11:0]	All 0	R	These bits hold the A/D conversion results.															
				<table border="1"> <thead> <tr> <th colspan="3">ADCR3 to ADCR0 Registers</th> </tr> <tr> <th>Analog Input Channel</th> <th>Select Mode with 1-Buffer Mode Selected or Scan Mode</th> <th>Select Mode with 4-Buffer Mode Selected</th> </tr> </thead> <tbody> <tr> <td>0</td> <td>ADCR0</td> <td rowspan="4">ADCR3 to ADCR0</td> </tr> <tr> <td>1</td> <td>ADCR1</td> </tr> <tr> <td>2</td> <td>—</td> </tr> <tr> <td>3</td> <td>—</td> </tr> </tbody> </table>	ADCR3 to ADCR0 Registers			Analog Input Channel	Select Mode with 1-Buffer Mode Selected or Scan Mode	Select Mode with 4-Buffer Mode Selected	0	ADCR0	ADCR3 to ADCR0	1	ADCR1	2	—	3	—
ADCR3 to ADCR0 Registers																			
Analog Input Channel	Select Mode with 1-Buffer Mode Selected or Scan Mode	Select Mode with 4-Buffer Mode Selected																	
0	ADCR0	ADCR3 to ADCR0																	
1	ADCR1																		
2	—																		
3	—																		

The following formula indicates the relationship between the analog input voltage that is input to analog input pins (ADC_CH1, ADC_CH0) and the A/D conversion results (A/D conversion result registers (ADCR3 to ADCR0)).

$$\text{ADCR} = \text{INT} \left[\frac{V_{\text{in}}}{\text{ADC_AVREF}} \times 2^d \times 0.5 \right]$$

or

$$(\text{ADCR} - 0.5) \times \frac{\text{ADC_AVREF}}{2^d} \leq V_{\text{in}} < (\text{ADCR} + 0.5) \times \frac{\text{ADC_AVREF}}{2^d}$$

INT[]: Function that returns the integer portion of the value enclosed in []

V_{in}: Analog input voltage

ADC_AVREF: Voltage of power supply pin(ADC_AVDD18) for the analog unit

ADCR: Value of A/D conversion result registers (ADCR3 to ADCR0)

d: Resolution of A/D converter (d = 12 in this LSI)

The relationship between the analog input voltage and A/D conversion result is shown in the figure below.

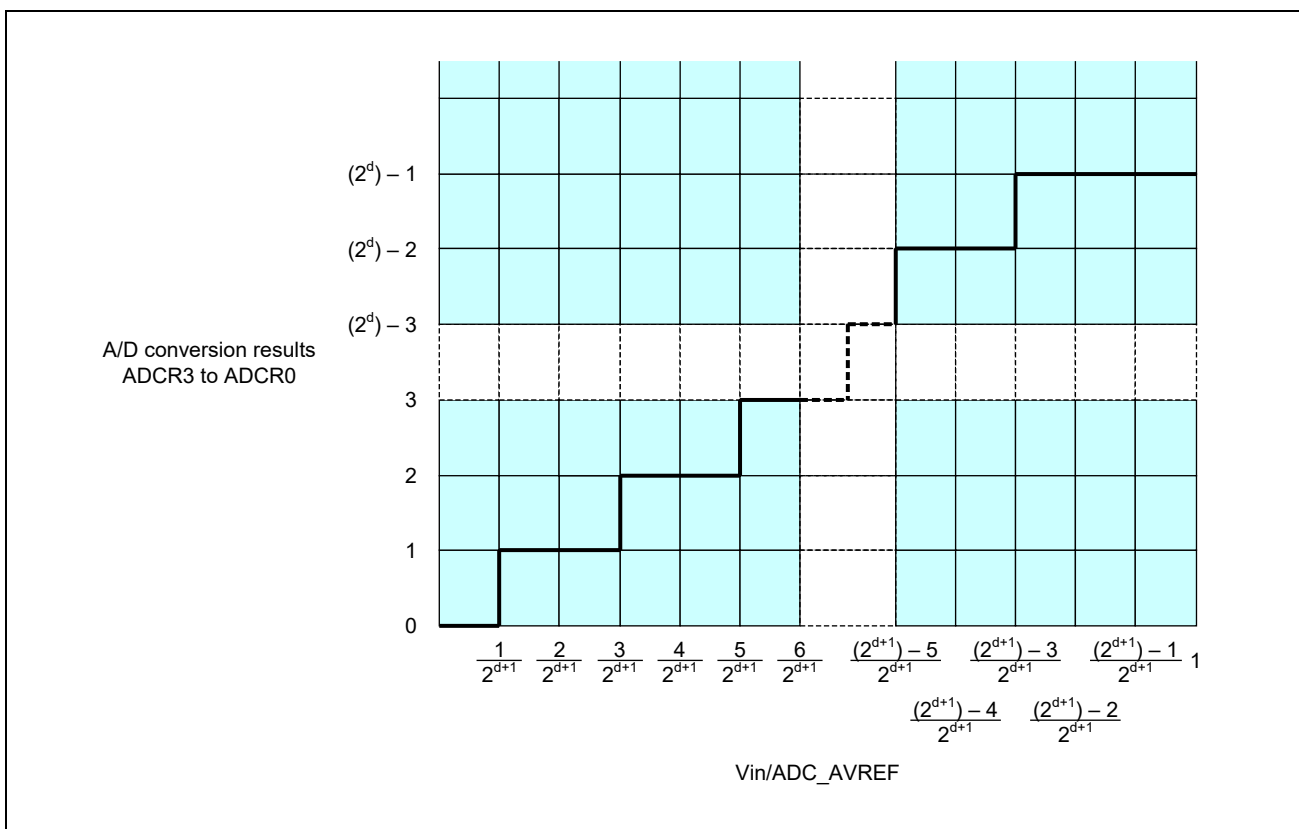

Figure 31.3 Relationship between Analog Input Voltage and A/D Conversion Result

31.4 Operation

31.4.1 Types of A/D Conversion Modes

The following A/D conversion modes can be specified. A/D conversion modes can be set in the ADM1 register.

Table 31.5 A/D Conversion Modes

Trigger Mode	Trigger Input Mode	Operating Mode	Conversion Count	Buffer Count	Operation	Example of A/D Conversion for Reference			
Software trigger	—	Select	Single	1 buffer	Selected 1 channel × 1-time conversion	Section 31.4.4.1, Example of A/D Conversion in Select Mode with Single Mode Selected			
				4 buffers	Selected 1 channel × 4-time conversion	—			
			Repeat	1 buffer	(Selected 1 channel × 1-time conversion) × repeated	Section 31.4.4.2, Example of A/D Conversion in Select Mode with Repeat Mode Selected			
				4 buffers	(Selected 1 channel × 4-time conversion) × repeated	Section 31.4.4.3, Example of A/D Conversion in 4-Buffer Mode			
			Scan	Single	1 buffer	All selected channels × 1-time conversion	Section 31.4.4.4, Example of A/D Conversion in Scan Mode with Single Mode Selected		
					4 buffers	(Setting prohibited)			
		Repeat		1 buffer	(All selected channels × 1-time conversion) × repeated	Section 31.4.4.5, Example of A/D Conversion in Scan Mode with Repeat Mode Selected			
				4 buffers	(Setting prohibited)				
		Hardware trigger	Auto (started with a single trigger input)	Select	Single	1 buffer	Selected 1 channel × 1-time conversion	—	
						4 buffers	Selected 1 channel × 4-time conversion	—	
					Repeat	1 buffer	(Selected 1 channel × 1-time conversion) × repeated	—	
						4 buffers	(Selected 1 channel × 4-time conversion) × repeated	—	
Scan	Single				1 buffer	All selected channels × 1-time conversion	Section 31.4.4.6, Example of A/D Conversion in Auto Mode		
					4 buffers	(Setting prohibited)			
	Repeat			1 buffer	(All selected channels × 1-time conversion) × repeated	—			
				4 buffers	(Setting prohibited)				
Step (conversion proceeds at every trigger input)	Select			Single	Single	1 buffer	Selected 1 channel × 1-time conversion	—	
						4 buffers	Selected 1 channel × 4-time conversion	—	
					Repeat	1 buffer	(Selected 1 channel × 1-time conversion) × repeated	—	
						4 buffers	(Selected 1 channel × 4-time conversion) × repeated	—	
					Scan	Single	1 buffer	All selected channels × 1-time conversion	Section 31.4.4.7, Example of A/D Conversion in Step Mode
							4 buffers	(Setting prohibited)	
				Repeat		1 buffer	(All selected channels × 1-time conversion) × repeated	—	
						4 buffers	(Setting prohibited)		

Note: When 4-buffer mode is set in scan mode, a channel select error occurs.

31.4.1.1 Trigger Modes

Software trigger mode and hardware trigger mode are the two types of trigger modes in which the trigger is the timing for starting the A/D conversion processing. These trigger modes can be set by the TRG bit in the ADM1 register.

(1) Software Trigger Mode

In software trigger mode, A/D conversion is started for the input of the ADC_CH1, ADC_CH0 pins by setting the ADCE bit in the ADM0 register to 1. The ADBSY bit in the ADM0 register is 1 while the converter is operating.

The hardware trigger is invalid when software trigger mode is set. Set the EGA[1:0] bits in the ADM1 register to 00 when using software trigger mode. When a hardware trigger is input, A/D conversion is not started and the TRGS bit in the ADSTS register retains 0.

(2) Hardware Trigger Mode

There are two triggers in hardware trigger mode: asynchronous trigger using the ADC_TRG pin as the activation source and synchronous trigger using the multi-function timer pulse unit 3 (MTU3a) as the activation source.

The valid edge of the selected hardware trigger can be set by the EGA[1:0] bits in the ADM1 register.

When the ADCE bit in the ADM0 register is set to 1, the A/D converter enters a standby state for a hardware trigger after 250 ns as passed and will start conversion operation upon detection of a valid edge. The ADBSY bit in the ADM0 register remains to be 1 during conversion operation.

The status of the TRGS bit in the ADSTS register can be cleared by writing 1 to the TRGS bit.

In hardware trigger mode, the available trigger input modes are auto mode and step mode. The trigger input mode can be set in the TRGIN bit in the ADM1 register.

(a) Auto mode

When a hardware trigger is input once, A/D conversion is repeated automatically for the conversion count in accordance with the specified conversion settings.

(b) Step mode

A/D conversion proceeds every time a hardware trigger is input. For example, if select mode, single mode, and 4-buffer mode are selected, conversion finishes when a hardware trigger has been input four times.

31.4.1.2 Operating mode

There are two operating modes: select mode and scan mode. The select mode has 1-buffer mode and 4-buffer mode as sub-modes. These modes can be set in the BS and MS bits in the ADM1 register.

(1) Select Mode

A/D conversion proceeds for the analog input specified in the CHSEL[1:0] bits in the ADM2 register. The A/D conversion results are stored in the ADCR3 to ADCR0 registers corresponding to the ADC_CH1, ADC_CH0 pins. In select mode, 1-buffer mode or 4-buffer mode can be used as the method for storing the A/D conversion results.

Only one channel is selectable for A/D conversion in select mode.

If more than one analog input channel is selected in select mode, a channel select error occurs.

(a) 1-buffer mode

A/D conversion proceeds only once for the analog input specified in the ADM2 register and the conversion result is stored in the ADCR3 to ADCR0 registers corresponding to the ADC_CH1, ADC_CH0 pins.

The ADC_CH1, ADC_CH0 pins correspond with the ADCR3 to ADCR0 registers on a one-on-one basis. If interrupt output is enabled in the INTEN[3:0] bits in the ADINT register for the channels on which A/D conversion proceeds, an A/D conversion end interrupt (INTAD) occurs on completion of a single conversion.

This mode is usable for reading the result of a single conversion.

(b) 4-buffer mode

A/D conversion proceeds four times for the analog input specified in the ADM2 register and the conversion results are stored ADCR3 to ADCR0 registers. See **Table 31.7** for the correspondence between the analog inputs and A/D conversion result registers.

If interrupt output is enabled in the INTEN[3:0] bits in the ADINT register for the channels corresponding to the ADCR3 to ADCR0 registers where the A/D conversion result is to be stored in 1-buffer mode, an A/D conversion end interrupt (INTAD) occurs when the A/D conversion result is stored in the ADCR3 to ADCR0 registers. For example, to generate an interrupt on the fourth A/D conversion when ADC_CH0 is selected, set the INTEN3 bit in the ADINT register to 1.

See **Table 31.6** for the relationship between the setting of the ADINT register and the output of an A/D conversion end interrupt in 4-buffer mode.

This mode is usable for obtaining the average of the A/D conversion results.

Table 31.6 ADINT Setting and Generation of A/D Conversion End Interrupt in 4-Buffer Mode

Channel for A/D Conversion	ADINT Register Setting	A/D Conversion End Interrupt	
1 channel is selected from ADC_CH1, ADC_CH0	INTEN[0]	1: Interrupt is enabled	An interrupt is output on completion of A/D conversion on channel 0.
		0: Interrupt is disabled	No interrupt is output on completion of A/D conversion on channel 0.
	INTEN[1]	1: Interrupt is enabled	An interrupt is output on completion of A/D conversion on channel 1.
		0: Interrupt is disabled	No interrupt is output on completion of A/D conversion on channel 1.
	INTEN[2]	1: Interrupt is enabled	An interrupt is output on completion of third A/D conversion (used only in 4-buffer mode).
		0: Interrupt is disabled	No interrupt is output on completion of A/D conversion.
	INTEN[3]	1: Interrupt is enabled	An interrupt is output on completion of fourth A/D conversion (used only in 4-buffer mode).
		0: Interrupt is disabled	No interrupt is output on completion of A/D conversion.

Table 31.7 Correspondence between Analog Inputs and A/D Conversion Result Registers in 4-Buffer Mode

Analog Input	A/D Conversion Result Register
1 channel is selected from ADC_CH1, ADC_CH0	ADCR0 (first time)
	ADCR1 (second time)
	ADCR2 (third time)
	ADCR3 (fourth time)

(2) Scan Mode

A/D conversion proceeds for the analog inputs of channels selected in the ADM2 register, in ascending order of channel number. The A/D conversion results are stored in the ADCR3 to ADCR0 registers corresponding to the analog inputs. If interrupt output is enabled in the INTEN[3:0] bits in the ADINT register for the channels on which A/D conversion proceeds, an A/D conversion end interrupt (INTAD) occurs when A/D conversion on the relevant channel finishes.

This mode is usable for constantly monitoring multiple analog signals.

In scan mode, only 1-buffer mode can be specified. If 4-buffer mode is specified in scan mode, a channel select error occurs.

31.4.1.3 Conversion Mode

Single mode and repeat mode are available. Use the RPS bit in the ADM1 register to set the conversion mode.

(1) Single Mode

When A/D conversion for the number of times of the conversion count finishes, the ADCE bit in the ADM0 register is automatically cleared to 0. For the number of times of conversion, see the description of operation in **Table 31.5**.

(2) Repeat Mode

When 1 is written to the ADCE bit in the ADM0 register, A/D conversion repeatedly proceeds in the A/D conversion mode specified in the ADM1 register. Immediately after 0 is written to the ADCE bit in the ADM0 register, A/D conversion is finished.

For the number of times of conversion, see the description of operation in **Table 31.5**.

31.4.2 Interrupt Functions

Table 31.8 lists the interrupt sources of the A/D converter and the conditions for generating them and the methods for confirming and clearing the interrupt sources.

The INTS bit in the ADINT register is used to set the operation for outputting an interrupt request of the INTAD.

Table 31.8 List of Interrupt Functions

Interrupt Source	Condition for Generation	Enabling Interrupt	Confirming Interrupt Source	Method for Clearing Interrupt Source
		ADINT Register	ADSTS Register* ¹	ADSTS Register
A/D conversion end	When A/D conversion on the specified channel is completed	INTEN[3:0]* ²	INTST[3:0]	Write 1 to the bits that were 1 when the register was read.
A/D conversion channel select error	<ul style="list-style-type: none"> • When all of the CHSEL[1:0] bits in the ADM2 register were 0 at the start of A/D conversion*³ • When multiple analog input channels are selected in select mode*³ • When 4-buffer mode is specified in scan mode*³ 	CSEEN	CSEST	Write 1 to the CSEST bit.

Note 1. If an interrupt source is generated regardless of the settings of the INTEN[3:0] and CSEEN bits in the ADINT register, the bit corresponding to the interrupt source is set to 1 in the ADSTS register.

Note 2. The A/D conversion end interrupt can be enabled or disabled individually for each channel.

Note 3. When an A/D conversion channel select error occurs, the ADCE bit in the ADM0 register becomes 0 and A/D conversion operation is stopped.

31.4.3 Procedures of A/D Conversion

Follow the procedures given below for A/D conversion.

(1) Procedure for starting A/D conversion

After the A/D converter is released from the software reset state, use the ADM3 to ADM0 registers*¹ to select the analog input channels on which A/D conversion proceeds and specify the trigger mode (software trigger or hardware trigger), operating mode (select or scan), etc.

Setting the ADCE bit in the ADM0 register to 1 will start A/D conversion in software trigger mode, whereas the A/D converter will enter a standby state for a trigger*² in hardware trigger mode.

Note 1. Set the ADM3 to ADM0 registers when conversion by the A/D converter is stopped (ADBSY bit in the ADM0 register is 0).

Note 2. If the ADCE bit in the ADM0 register is set to 1 in hardware trigger mode, a transition is made to a trigger standby state. A/D conversion is started (ADBSY bit in ADM0 register is 1) by a hardware trigger signal and the A/D converter returns to the trigger standby state (ADBSY bit in ADM0 register is 0) on completion of A/D conversion.

A/D conversion operation is enabled.

After the A/D converter makes a transition from power-saving mode to normal mode, a period as long as the stabilization wait time is required. The stabilization wait time is 1 μ s.

After the stabilization wait time has passed, set the ADCE bit in the ADM0 register to 1.

In software trigger mode, setting the ADCE bit to 1 starts A/D conversion.

In hardware trigger mode, setting the ADCE bit to 1 makes the A/D converter enter a standby state for a hardware trigger after 250 ns has passed, and conversion operation is started upon detection of a valid edge.

(2) When A/D conversion is finished, the A/D conversion results are stored in the ADCR3 to ADCR0 registers. Also, an A/D conversion end interrupt (INTAD) occurs on completion of A/D conversion on the channels specified in the INTEN[3:0] bits in the ADINT register.

31.4.3.1 Procedure for Starting A/D Conversion

Use the following flowchart to start A/D conversion.

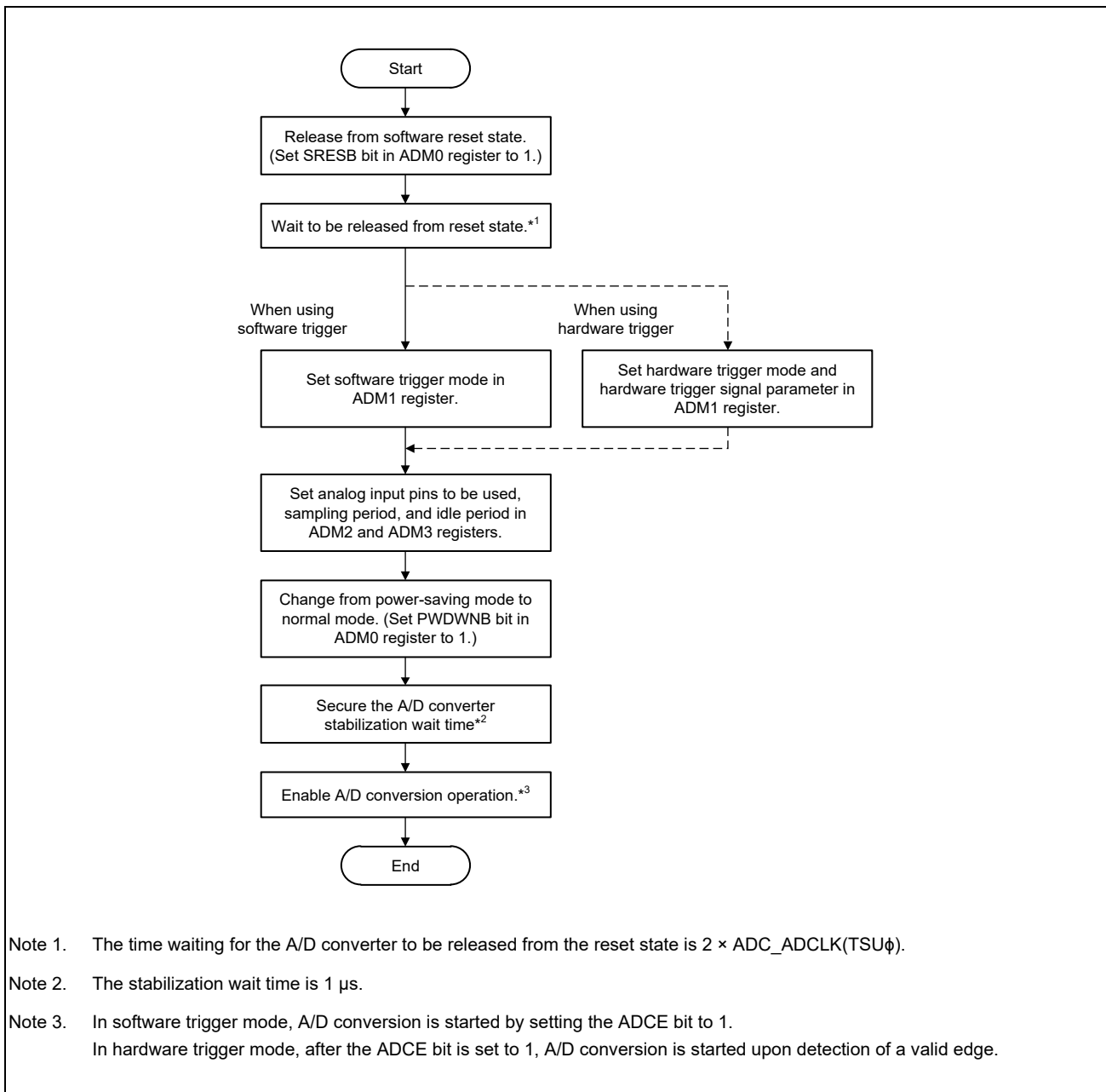

Figure 31.4 Procedure for Starting A/D Conversion

31.4.3.2 Procedure for Stopping A/D Conversion

Use the following flowchart to stop A/D conversion.

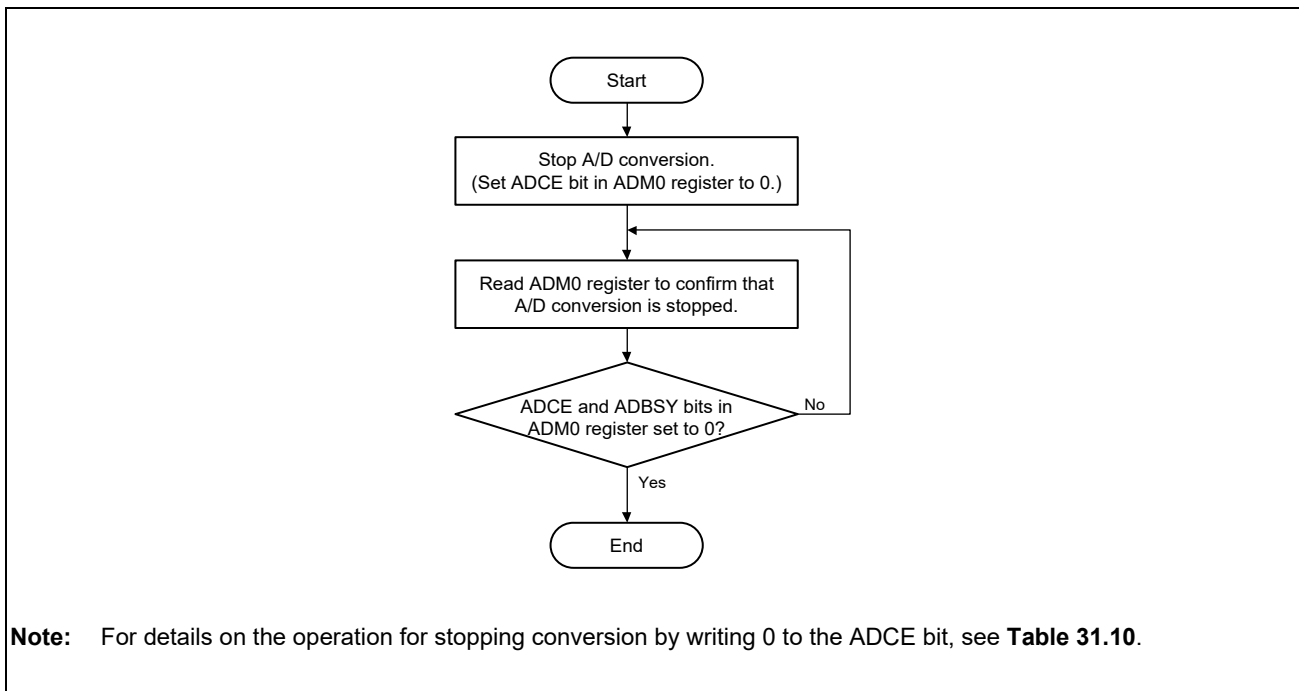

Figure 31.5 Procedure for Stopping A/D Conversion

31.4.3.3 Procedure for Stopping and Restarting A/D Conversion

Use the following flowchart to restart A/D conversion after it has been stopped with the procedure for stopping A/D conversion.

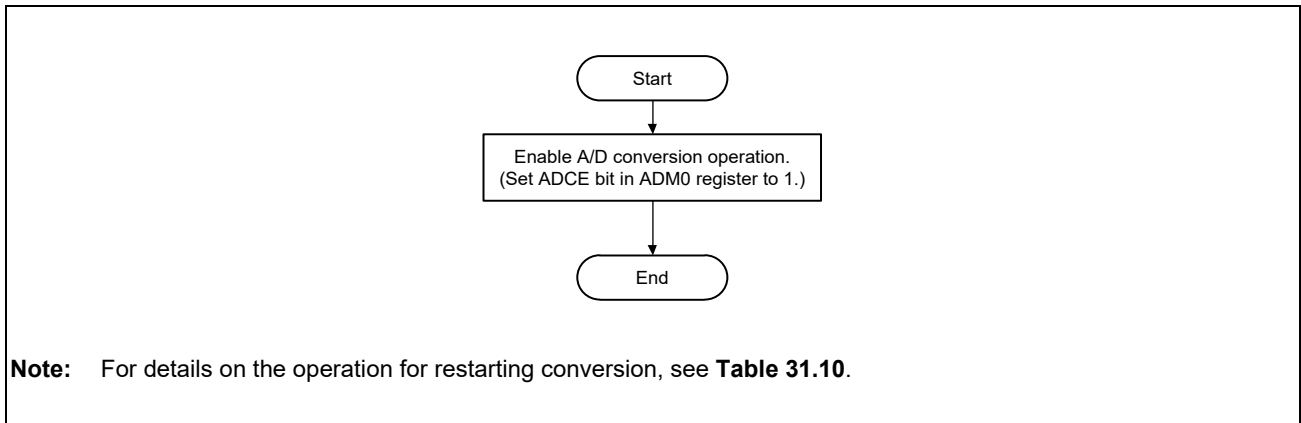

Figure 31.6 Procedure for Stopping and Restarting A/D Conversion

31.4.3.4 Procedure for Entering Power-saving Mode

Use the following flowchart to make a transition to the power-saving mode.

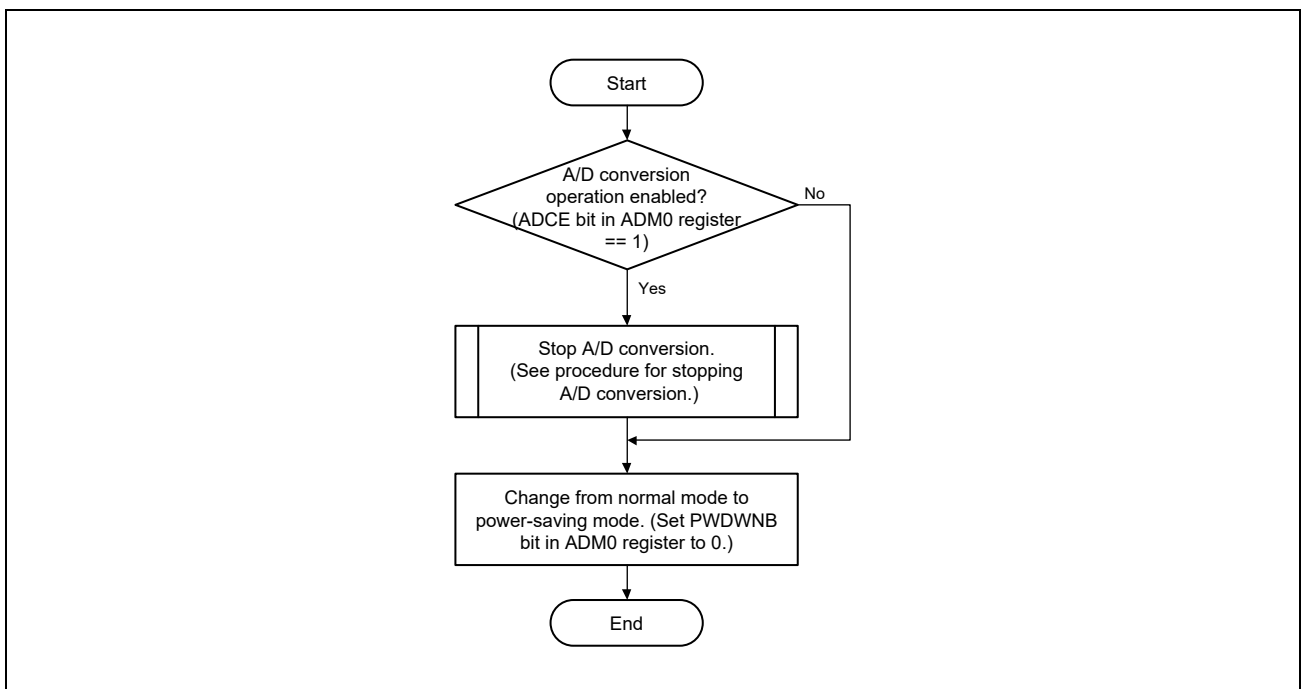

Figure 31.7 Procedure for Entering Power-Saving Mode

31.4.3.5 Procedure for Releasing from Power-saving Mode

Use the following flowchart to release the A/D converter from the power-saving mode.

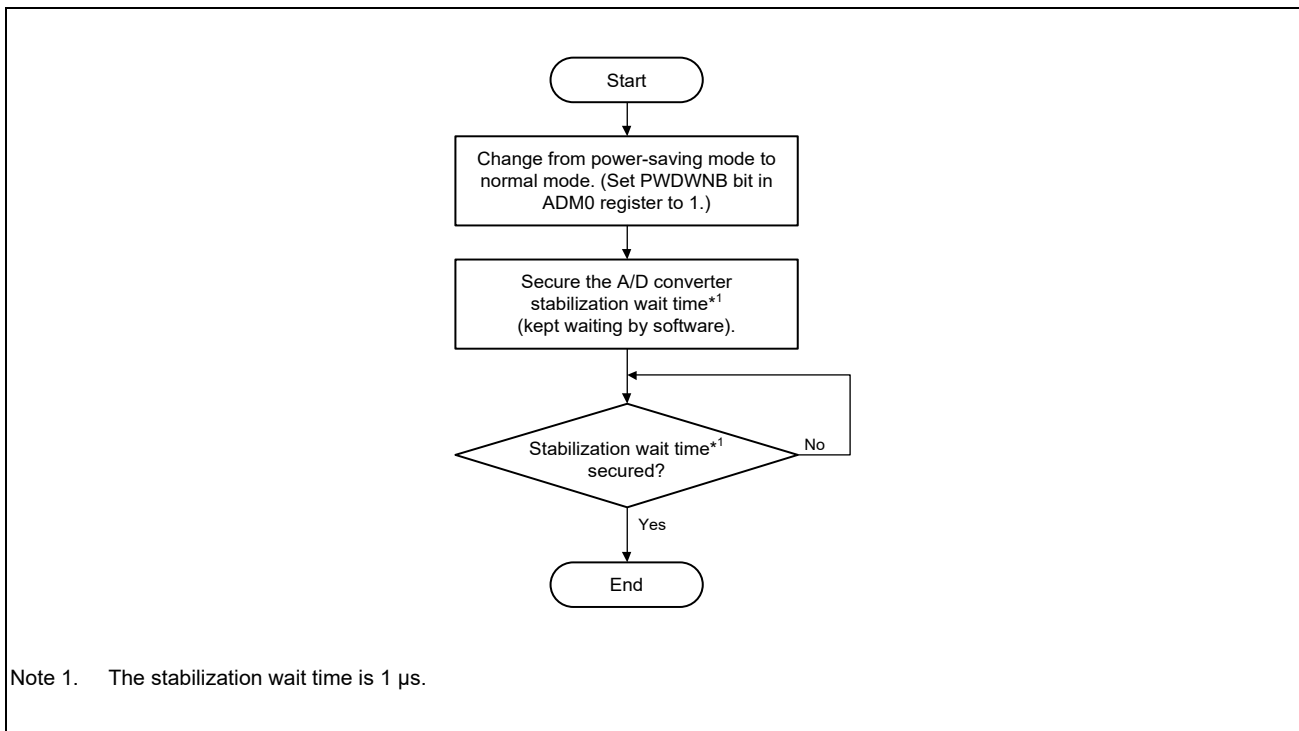

Figure 31.8 Procedure for Releasing from Power-Saving Mode

31.4.3.6 Procedure for a Software Reset

Use the following flowchart to execute a software reset.

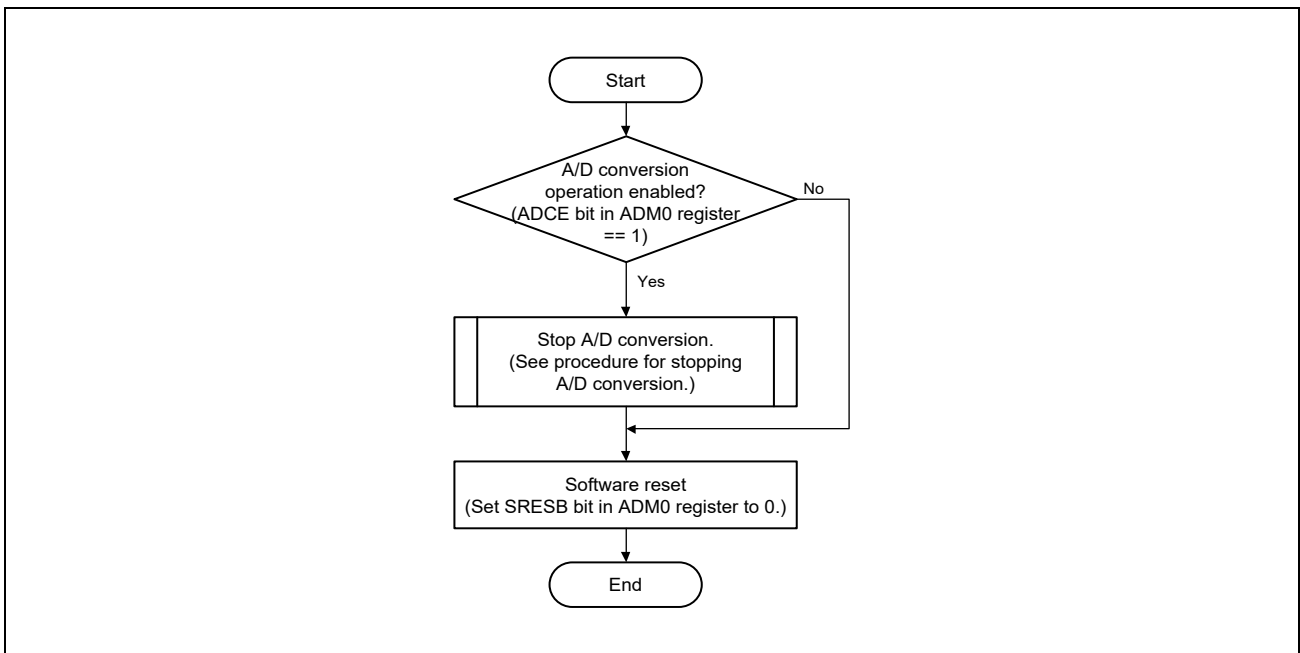

Figure 31.9 Procedure for a Software Reset

31.4.3.7 Procedure for Restarting A/D Conversion after a Software Reset

Use the following flowchart to start A/D conversion, then execute a software reset with the procedure for a software reset, and finally restart A/D conversion.

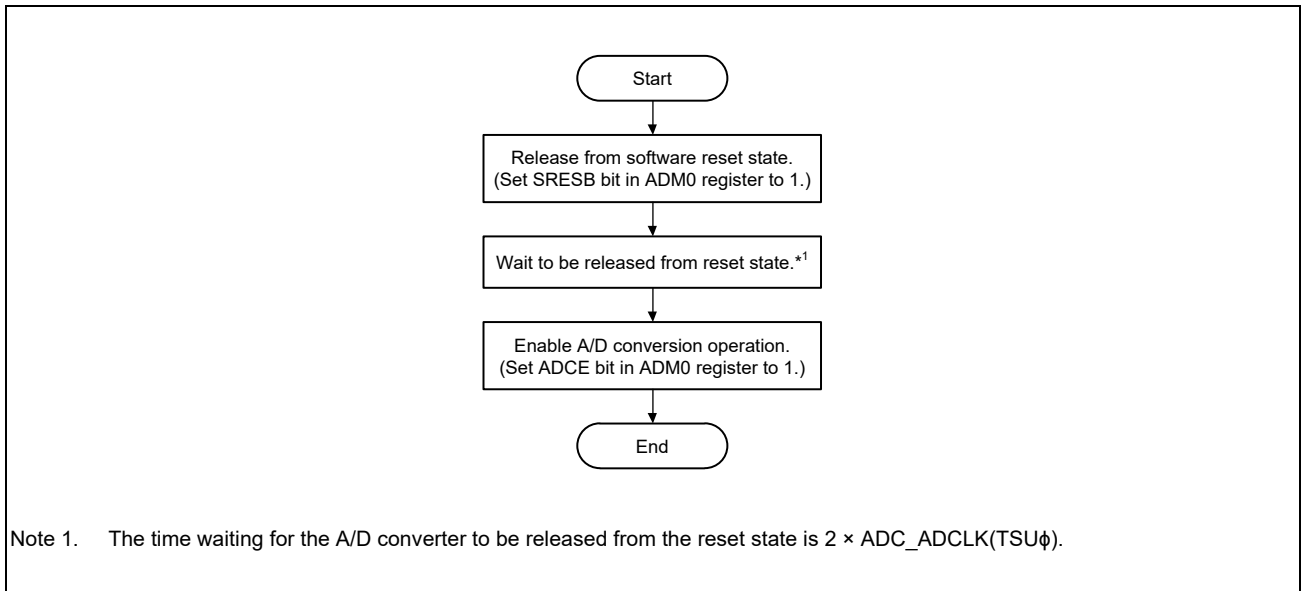

Figure 31.10 Procedure for Restarting A/D Conversion after a Software Reset

31.4.3.8 Procedure for Interrupt Processing

Use the flowchart in **Figure 31.11** to process an interrupt request that was output by the A/D converter.

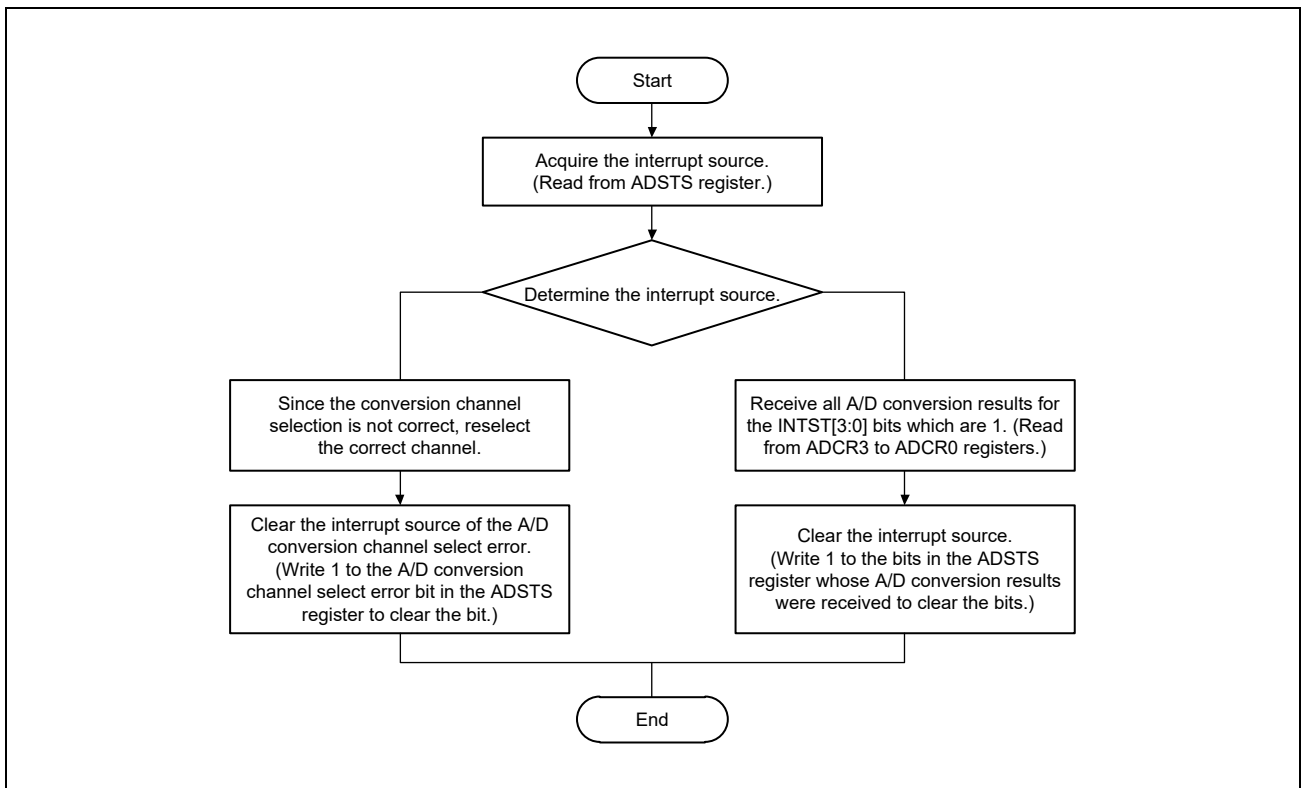

Figure 31.11 Procedure for Interrupt Processing

31.4.4 Examples of A/D Conversion

This section gives examples of A/D conversion.

- 1) Example of A/D conversion in select mode with single mode selected
- 2) Example of A/D conversion in select mode with repeat mode selected
- 3) Example of A/D conversion in 4-buffer mode
- 4) Example of A/D conversion in scan mode with single mode selected
- 5) Example of A/D conversion in scan mode with repeat mode selected
- 6) Example of A/D conversion in auto mode
- 7) Example of A/D conversion in step mode

Note to confirm the differences between modes shown below because not all possible combinations are included in this manual.

- For the differences between 1-buffer mode and 4-buffer mode, refer to 1) and 3).
- For the differences between single mode and repeat mode, refer to 1) and 2).
- For the differences between select mode and scan mode, refer to 1) and 4) or 2) and 5)
- For the differences between auto mode and step mode, refer to 6) and 7)
- For the differences between software trigger mode and hardware trigger mode, refer to 4) and 6).

31.4.4.1 Example of A/D Conversion in Select Mode with Single Mode Selected

Figure 31.12 shows an example of A/D conversion with software trigger mode, select mode, single mode and 1-buffer mode are selected. In the example in **Figure 31.12**, conversion proceeds with the analog input changed from ADC_CH0, ADC_CH1.

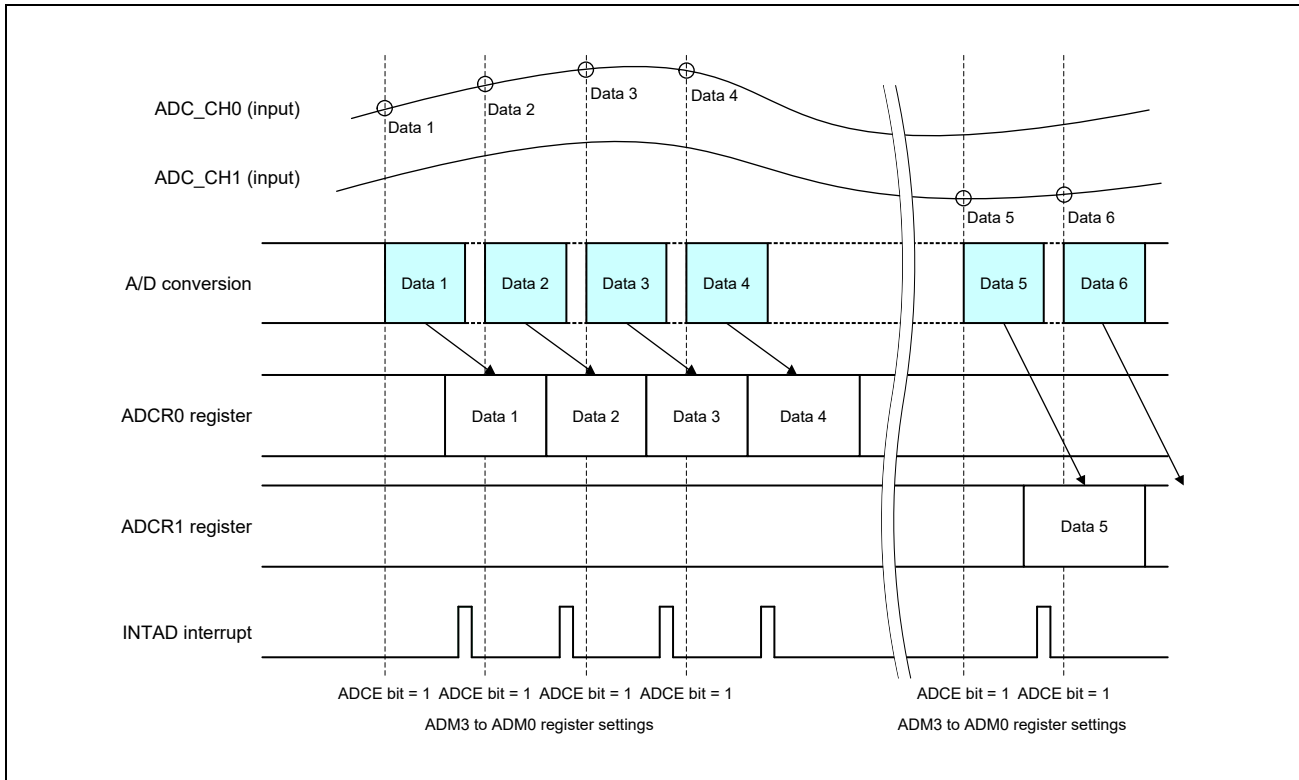

Figure 31.12 Example of A/D Conversion in Select Mode with Single Mode Selected

1. The SRESB bit in the ADM0 register is set to 1 to release the A/D converter from the software reset state.
2. The A/D converter waits to be released from the reset state (wait time is $2 \times \text{ADC_ADCLK}(\text{TSU}\phi)$).
3. In the ADM3 to ADM0 registers, software trigger mode, select mode, single mode, and 1-buffer mode are selected, and analog input pin ADC_CH0 is set.
4. In the ADINT and ADSTS registers, the interrupt signal is set as a pulse and interrupt output of channel 0 is enabled.
5. Normal mode is selected by setting the PWDWNB bit in the ADM0 register to 1.
6. The A/D converter is kept waiting for a period equal to or longer than the stabilization wait time*¹ by software.
7. A/D conversion operation is enabled by setting the ADCE bit in the ADM0 register to 1 (A/D conversion is started).
8. A/D conversion proceeds on ADC_CH0 (A/D conversion result is stored in the ADCR0 register).
9. An INTAD interrupt occurs.
10. Steps 7 to 9 above are repeated.
11. A/D conversion operation is stopped by setting the ADCE bit in the ADM0 register to 0.
12. In the ADM3 to ADM0 registers, software trigger mode, select mode, single mode, and 1-buffer mode are selected, and analog input pin ADC_CH1 is set.

13. A/D conversion operation is enabled by setting the ADCE bit in the ADM0 register to 1 (A/D conversion is started).
14. A/D conversion proceeds on ADC_CH1 (A/D conversion result is stored in the ADCR1 register).
15. An INTAD interrupt occurs.
16. Steps 13 to 15 above are repeated.

Note 1. The stabilization wait time is 1 μ s.

31.4.4.2 Example of A/D Conversion in Select Mode with Repeat Mode Selected

Figure 31.13 shows an example of A/D conversion with software trigger mode, select mode, repeat mode, and 1-buffer mode are selected. In the example in Figure 31.13, conversion proceeds with the analog input changed from ADC_CH0, ADC_CH1.

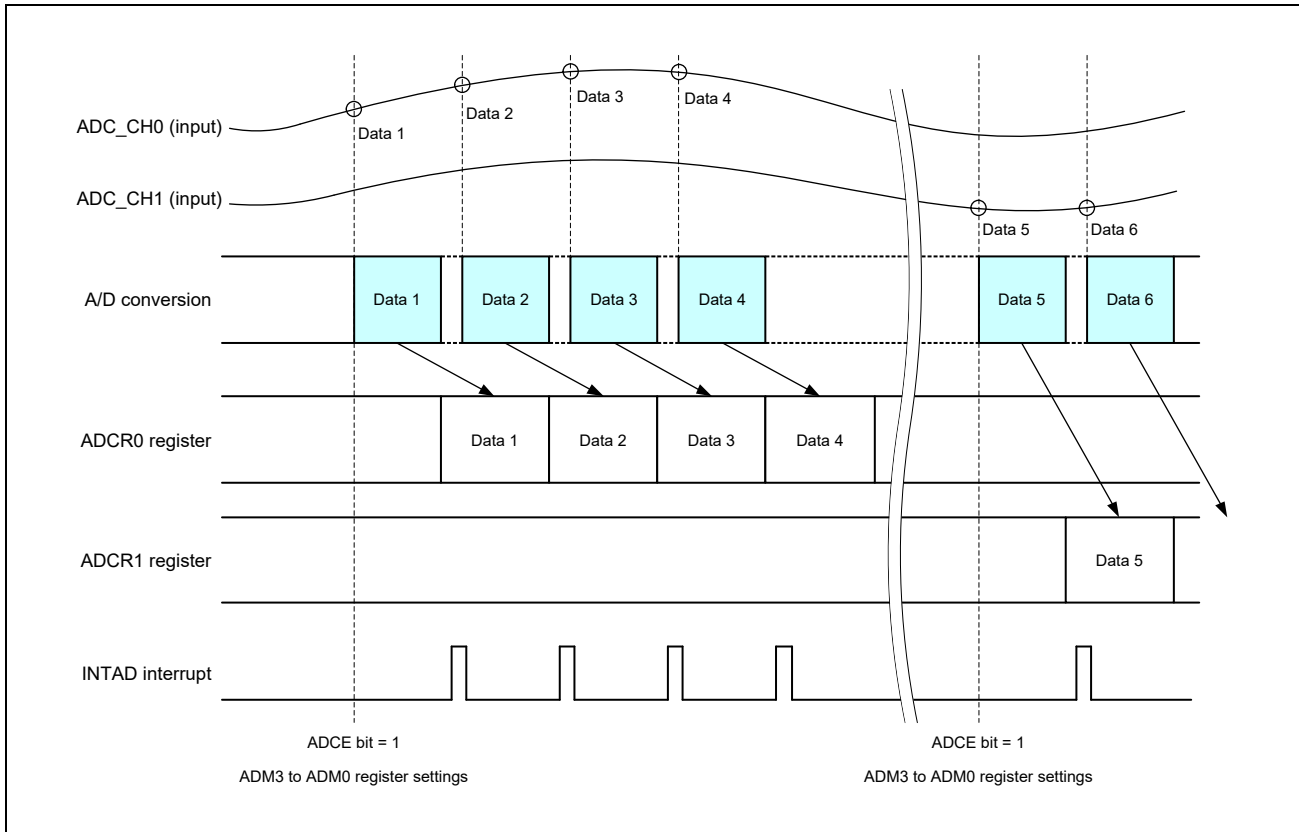

Figure 31.13 Example of A/D Conversion in Select Mode with Repeat Mode Selected

1. The SRESB bit in the ADM0 register is set to 1 to release the A/D converter from the software reset state.
2. The A/D converter waits to be released from the reset state (wait time is $2 \times \text{ADC_ADCLK}(\text{TSU}\phi)$).
3. In the ADM3 to ADM0 registers, software trigger mode, select mode, repeat mode, and 1-buffer mode are selected, and analog input pin ADC_CH0 is set.
4. In the ADINT and ADSTS registers, the interrupt signal is set as a pulse and interrupt output of channel 0 is enabled.
5. Normal mode is selected by setting the PWDWNB bit in the ADM0 register to 1.
6. The A/D converter is kept waiting for a period equal to or longer than the stabilization wait time*¹ by software.
7. A/D conversion operation is enabled by setting the ADCE bit in the ADM0 register to 1 (A/D conversion is started).
8. A/D conversion proceeds on ADC_CH0 (A/D conversion result is stored in the ADCR0 register).
9. An INTAD interrupt occurs.
10. Steps 8 and 9 above are repeated automatically.
11. A/D conversion operation is stopped by setting the ADCE bit in the ADM0 register to 0.

12. In the ADM3 to ADM0 registers, software trigger mode, select mode, repeat mode, 1-buffer mode are selected, and analog input pin ADC_CH1 is set.
13. A/D conversion operation is enabled by setting the ADCE bit in the ADM0 register to 1 (A/D conversion is started).
14. A/D conversion proceeds on ADC_CH1 (A/D conversion result is stored in the ADCR1 register).
15. An INTAD interrupt occurs.
16. Steps 14 and 15 above are repeated.

Note 1. The stabilization wait time is 1 μ s.

31.4.4.3 Example of A/D Conversion in 4-Buffer Mode

Figure 31.14 shows an example of A/D conversion with software trigger mode, select mode, repeat mode, and 4-buffer mode are selected. In the example in Figure 31.14, conversion proceeds with ADC_CH0 selected.

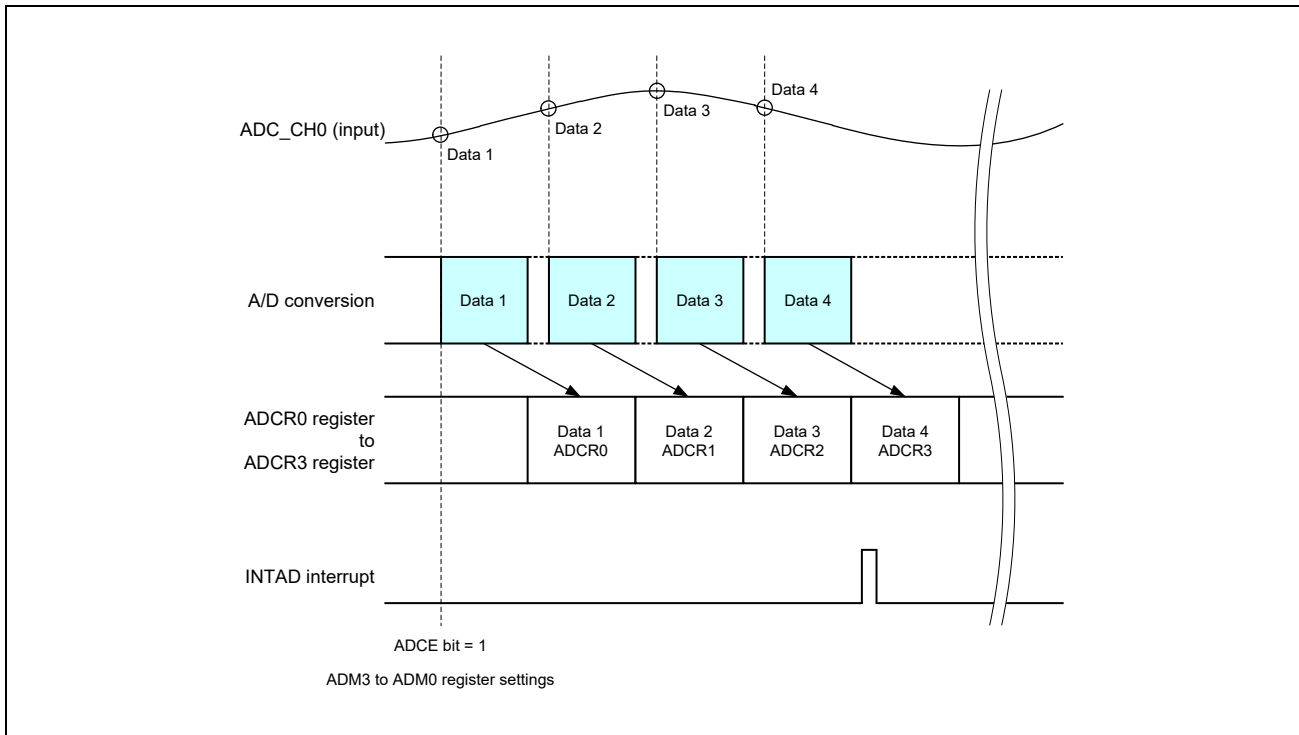

Figure 31.14 Example of A/D Conversion in 4-Buffer Mode

1. The SRESB bit in the ADM0 register is set to 1 to release the A/D converter from the software reset state.
2. The A/D converter waits to be released from the reset state (wait time is $2 \times \text{ADC_ADCLK}(\text{TSU}\phi)$).
3. In the ADM3 to ADM0 registers, software trigger mode, select mode, repeat mode, and 4-buffer mode are selected, and analog input pin ADC_CH0 is set.
4. In the ADINT and ADSTS registers, the interrupt signal is set as a pulse and interrupt output of channel 3 is enabled.
5. Normal mode is selected by setting the PWDWNB bit in the ADM0 register to 1.
6. The A/D converter is kept waiting for a period equal to or longer than the stabilization wait time*1 by software.
7. A/D conversion operation is enabled by setting the ADCE bit in the ADM0 register to 1 (A/D conversion is started).
8. A/D conversion proceeds on ADC_CH0 (A/D conversion result (data 1) is stored in the ADCR0 register).
9. A/D conversion proceeds on ADC_CH0 (A/D conversion result (data 2) is stored in the ADCR1 register).
10. A/D conversion proceeds on ADC_CH0 (A/D conversion result (data 3) is stored in the ADCR2 register).
11. A/D conversion proceeds on ADC_CH0 (A/D conversion result (data 4) is stored in the ADCR3 register).
12. An INTAD interrupt occurs.
13. Steps 8 to 12 above are repeated automatically.
14. A/D conversion operation is stopped by setting the ADCE bit in the ADM0 register to 0.

Note 1. The stabilization wait time is 1 μ s.

31.4.4.4 Example of A/D Conversion in Scan Mode with Single Mode Selected

Figure 31.15 shows an example of A/D conversion with software trigger mode, scan mode, and single mode are selected. In the example in Figure 31.15, conversion proceeds with ADC_CH1, ADC_CH0 selected.

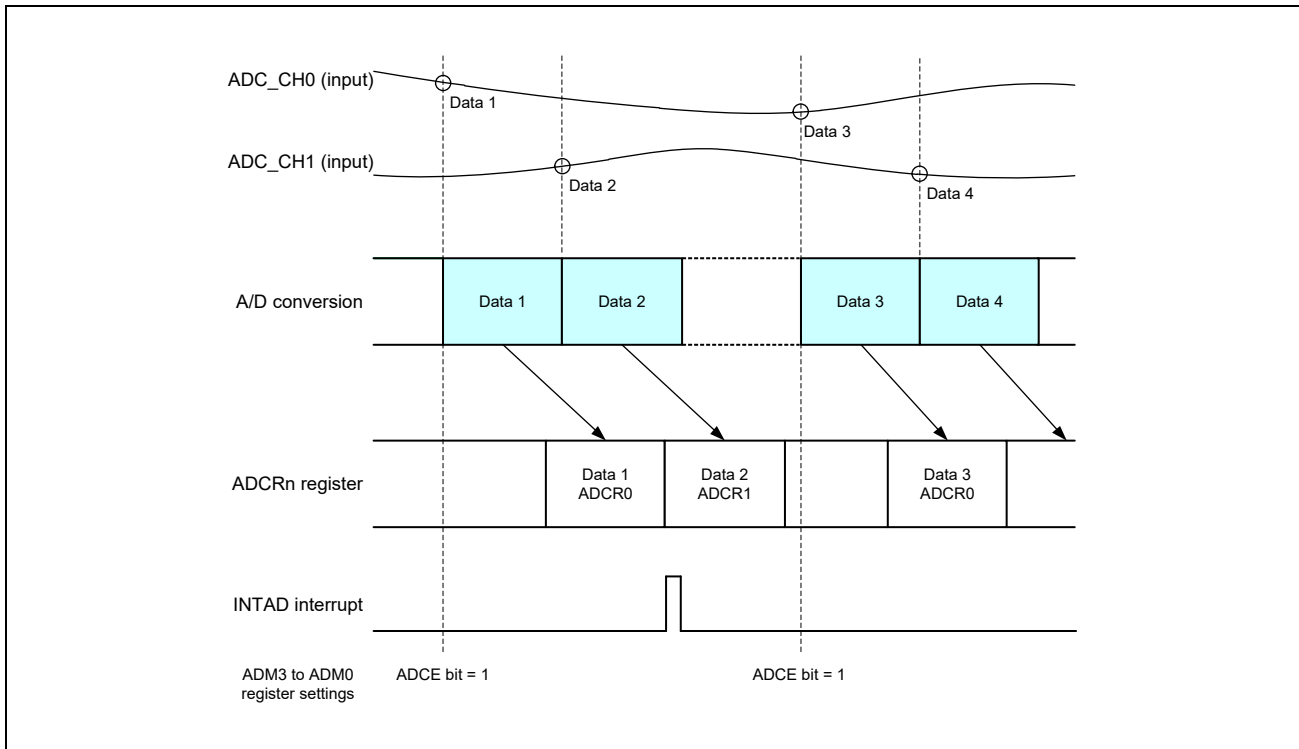

Figure 31.15 Example of A/D Conversion in Scan Mode with Single Mode Selected

1. The SRESB bit in the ADM0 register is set to 1 to release the A/D converter from the software reset state.
2. The A/D converter waits to be released from the reset state (wait time is $2 \times \text{ADC_ADCLK}(\text{TSU}\phi)$).
3. In the ADM3 to ADM0 registers, software trigger mode, scan mode, and single mode are selected, and analog input pins ADC_CH1, ADC_CH0 are set.
4. In the ADINT and ADSTS registers, the interrupt signal is set as a pulse and interrupt output of channel 1 is enabled.
5. Normal mode is selected by setting the PWDWNB bit in the ADM0 register to 1.
6. The A/D converter is kept waiting for a period equal to or longer than the stabilization wait time*¹ by software.
7. A/D conversion operation is enabled by setting the ADCE bit in the ADM0 register to 1 (A/D conversion is started).
8. A/D conversion proceeds on ADC_CH0 (A/D conversion result (data 1) is stored in the ADCR0 register).
9. A/D conversion proceeds on ADC_CH1 (A/D conversion result (data 2) is stored in the ADCR1 register).
10. An INTAD interrupt occurs.
11. Steps 7 to 10 above are repeated.

Note 1. The stabilization wait time is 1 μs .

31.4.4.5 Example of A/D Conversion in Scan Mode with Repeat Mode Selected

Figure 31.16 shows an example of A/D conversion with software trigger mode, scan mode, and repeat mode are selected. In the example in **Figure 31.16**, conversion proceeds with ADC_CH1, ADC_CH0 selected.

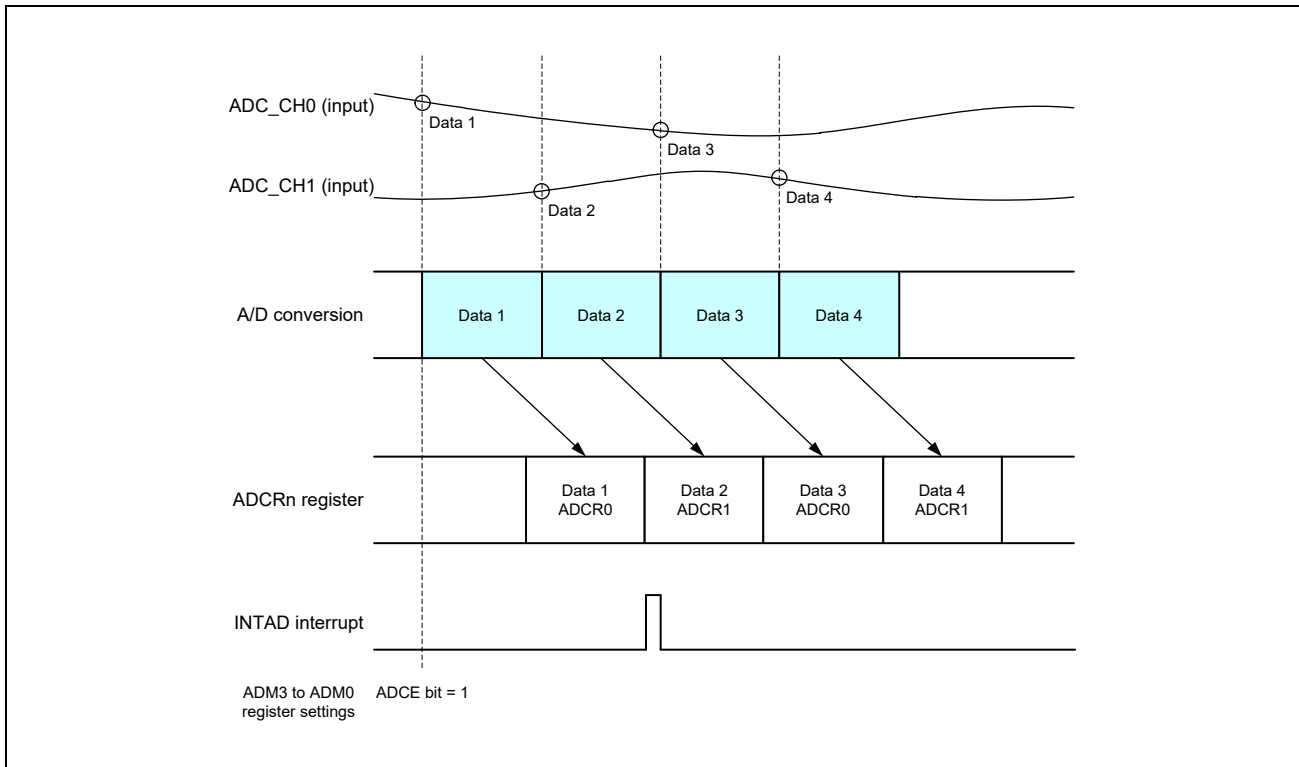

Figure 31.16 Example of A/D Conversion in Scan Mode with Repeat Mode Selected

1. The SRESB bit in the ADM0 register is set to 1 to release the A/D converter from the software reset state.
2. The A/D converter waits to be released from the reset state (wait time is $2 \times \text{ADC_ADCLK}(\text{TSU}\phi)$).
3. In the ADM3 to ADM0 registers, software trigger mode, scan mode, and repeat mode are selected and analog input pins ADC_CH1, ADC_CH0 are set.
4. In the ADINT and ADSTS registers, the interrupt signal is set as a pulse and interrupt output of channel 1 is enabled.
5. Normal mode is selected by setting the PWDWNB bit in the ADM0 register to 1.
6. The A/D converter is kept waiting for a period equal to or longer than the stabilization wait time*1 by software.
7. A/D conversion operation is enabled by setting the ADCE bit in the ADM0 register to 1 (A/D conversion is started).
8. A/D conversion proceeds on ADC_CH0 (A/D conversion result (data 1) is stored in the ADCR0 register).
9. A/D conversion proceeds on ADC_CH1 (A/D conversion result (data 2) is stored in the ADCR1 register).
10. An INTAD interrupt occurs.
11. Steps 8 to 10 above are repeated automatically.

Note 1. The stabilization wait time is 1 μs .

31.4.4.6 Example of A/D Conversion in Auto Mode

Figure 31.17 shows an example of A/D conversion with hardware trigger mode, auto mode, scan mode, and single mode are selected. In the example in Figure 31.17, conversion proceeds with ADC_CH1, ADC_CH0 selected.

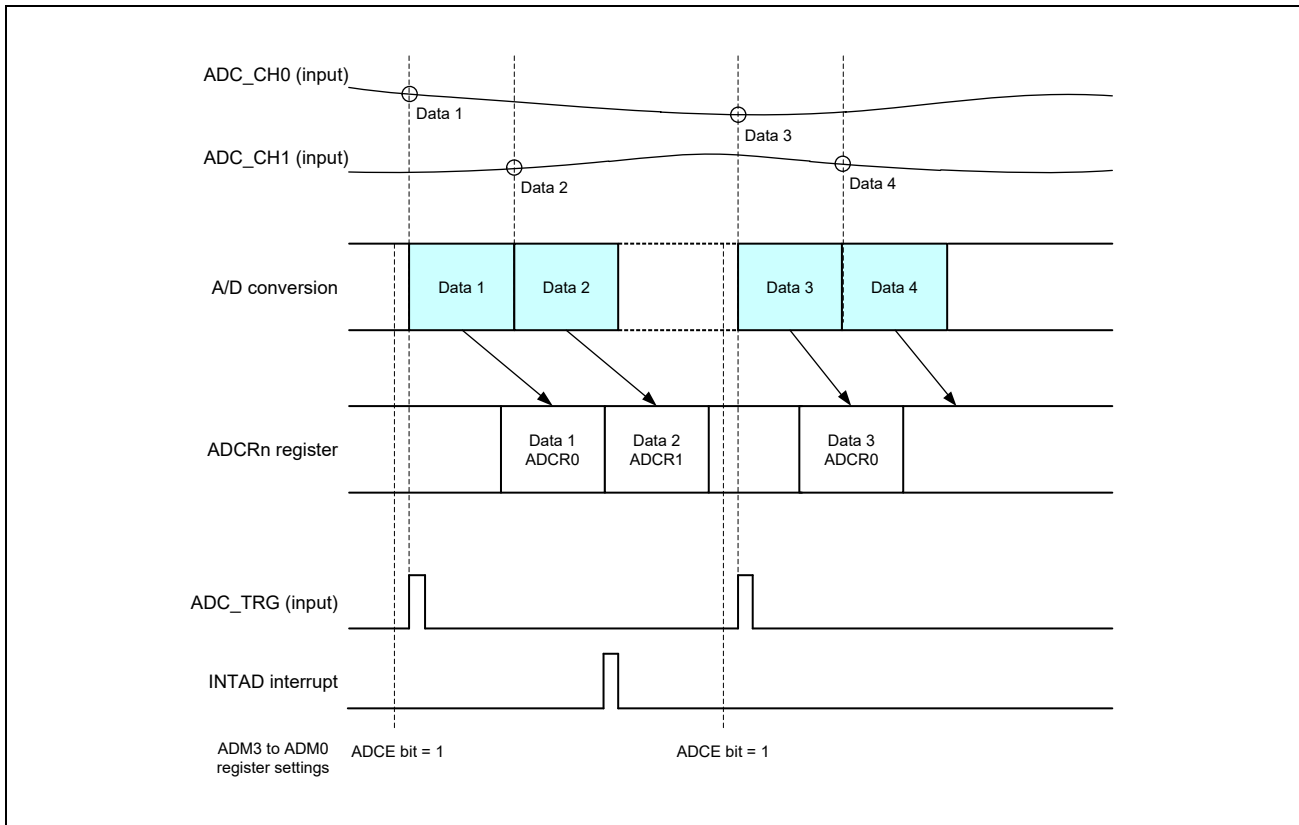

Figure 31.17 Example of A/D Conversion in Auto Mode

1. The SRESB bit in the ADM0 register is set to 1 to release the A/D converter from the software reset state.
2. The A/D converter waits to be released from the reset state (wait time is $2 \times \text{ADC_ADCLK}(\text{TSU}\phi)$).
3. In the ADM3 to ADM0 registers, hardware trigger mode, auto mode, scan mode, and single mode are selected, and analog input pins ADC_CH1, ADC_CH0 are set, the trigger of the ADC_TRG pin is enabled, and rising-edge detection of the hardware trigger is set.
4. In the ADINT and ADSTS registers, the interrupt signal is set as a pulse and interrupt output of channel 1 is enabled.
5. Normal mode is selected by setting the PWDWNB bit in the ADM0 register to 1.
6. The A/D converter is kept waiting for a period equal to or longer than the stabilization wait time*¹ by software.
7. A/D conversion operation is enabled by setting the ADCE bit in the ADM0 register to 1 (A/D conversion is started).
8. After 250 ns that is the period it takes for accepting a trigger, a rising edge of the pulse is input to the ADC_TRG pin (A/D conversion is started).
9. A/D conversion proceeds on ADC_CH0 (A/D conversion result (data 1) is stored in the ADCR0 register).
10. A/D conversion proceeds on ADC_CH1 (A/D conversion result (data 2) is stored in the ADCR1 register).
11. An INTAD interrupt occurs.

12. Steps 7 to 11 above are repeated.

Note 1. The stabilization wait time is 1 μ s.

31.4.4.7 Example of A/D Conversion in Step Mode

Figure 31.18 shows an example of A/D conversion with hardware trigger mode, step mode, scan mode, and single mode are selected. In the example in **Figure 31.18**, conversion proceeds with ADC_CH1, ADC_CH0 selected.

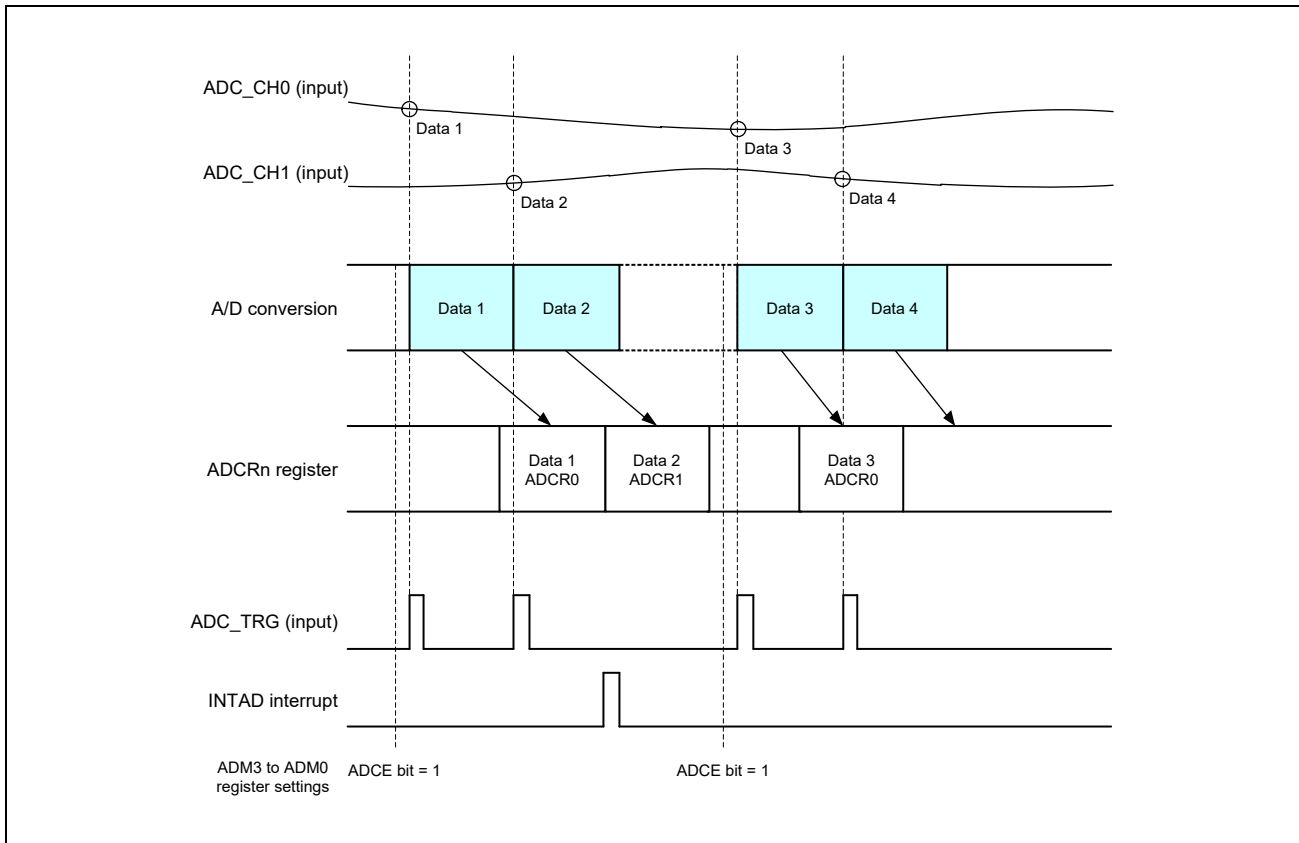

Figure 31.18 Example of A/D Conversion in Step Mode

1. The SRESB bit in the ADM0 register is set to 1 to release the A/D converter from the software reset state.
2. The A/D converter waits to be released from the reset state (wait time is $2 \times \text{ADC_ADCLK}(\text{TSU}\phi)$).
3. In the ADM3 to ADM0 registers, hardware trigger mode, step mode, scan mode, and single mode are selected, analog input pins ADC_CH1, ADC_CH0 are set, the trigger of the ADC_TRG pin is enabled, and rising-edge detection of the hardware trigger is set.
4. In the ADINT and ADSTS registers, the interrupt signal is set as a pulse and interrupt output of channel 1 is enabled.
5. Normal mode is selected by setting the PWDWNB bit in the ADM0 register to 1.
6. The A/D converter is kept waiting for a period equal to or longer than the stabilization wait time*¹ by software.
7. A/D conversion operation is enabled by setting the ADCE bit in the ADM0 register to 1.
8. After 250 ns that is the period it takes for accepting a trigger, a rising edge of the pulse is input to the ADC_TRG pin (A/D conversion is started).
9. A/D conversion proceeds on ADC_CH0 (A/D conversion result (data 1) is stored in the ADCR0 register).
10. After 250 ns that is the period it takes for accepting a trigger, a rising edge of the pulse is input to the ADC_TRG pin (A/D conversion is started).

11. A/D conversion proceeds on ADC_CH1 (A/D conversion result (data 2) is stored in the ADCR1 register).
12. An INTAD interrupt occurs.
13. Steps 7 to 12 above are repeated.

Note 1. The stabilization wait time is 1 μ s.

31.5 Notes

31.5.1 Interval of Hardware Trigger

The interval (interval of input time) of a trigger in hardware trigger mode must be longer than the A/D conversion time. For the A/D conversion time, see **Section 31.3.4, A/D Converter Mode Register 3 (ADM3)**.

31.5.2 Timing Restrictions

This A/D converter has restrictions on the timing interval, which are caused by the asynchronism countermeasure circuit. The restrictions shown in **Table 31.9** need to be met. If an access is made in a period shorter than this interval, the register values on the ADC_PCLK(P0φ) side are not reflected in the registers on the ADC_ADCLK(TSUφ) side because the notification of register update does not reach the ADC_ADCLK(TSUφ) side.

Table 31.9 Restrictions on Timing Interval

Condition	Restriction
Writing to the same register successively	(Interval of write access) $\geq (6 \times \text{ADC_PCLK(P0}\phi) + 6 \times \text{ADC_ADCLK(TSU}\phi))$
Interval of A/D conversion	(A/D conversion time) $\geq (6 \times \text{ADC_PCLK(P0}\phi) + 6 \times \text{ADC_ADCLK(TSU}\phi))$

Note: For the A/D conversion time, see **Figure 31.2**.

31.5.3 Restrictions on ADC_PCLK(P0φ) and ADC_ADCLK(TSUφ) Cycles

The ADC_PCLK(P0φ) and ADC_ADCLK(TSUφ) cycles need to satisfy the relation in the following formula.

$$\frac{\text{ADC_ADCLK(TSU}\phi) \leq (\text{A/D conversion time})}{6 - \text{ADC_PCLK(P0}\phi)}$$

Note: For the A/D conversion time, see **Figure 31.2**.

31.5.4 Operation when Stopping or Restarting A/D Conversion

When 0 is written to the ADCE bit in the ADM0 register, the A/D converter stops A/D conversion. A/D conversion is restarted by writing 0 to the ADCE bit in the ADM0 register once and then writing 1 to the same bit. Even though there was an instruction to stop A/D conversion, A/D conversion may not stop immediately. **Table 31.10** shows the operation for stopping conversion and also the operation for restarting conversion after it has been stopped.

Table 31.10 Operation when Stopping or Restarting A/D Conversion with the ADCE Bit

A/D Conversion Modes					Timing for Stopping Conversion when Stop is Instructed with ADCE = 0	Operation for Restarting Conversion		
Trigger		Operating Mode	Conversion Count	Buffer Count				
Mode	Input							
Software	—	Select	Single	1	Stopped on completion of 1-time conversion.	Conversion proceeds on the channel selected in the ADM2 register.		
				4	Stopped on completion of conversion in which there was an instruction to stop in the middle of 4-time conversion.	Same as above		
			Repeat	1	Stopped on completion of 1-time conversion.	Same as above		
				4	Stopped on completion of conversion in which there was an instruction to stop in the middle of 4-time conversion.	Same as above		
			Scan	Single	1	Stopped on completion of conversion in which there was an instruction to stop in the middle of scanning.	Conversion proceeds from the smallest channel number selected in the ADM2 register.	
					4	(Setting prohibited)	(Setting prohibited)	
				Repeat	1	Stopped on completion of conversion in which there was an instruction to stop in the middle of scanning.	Conversion proceeds from the smallest channel number selected in the ADM2 register.	
					4	(Setting prohibited)	(Setting prohibited)	
		Hardware	Auto mode	Select	Single	1	Same as software trigger mode	Same as software trigger mode
						4	Same as above	Same as above
					Repeat	1	Same as above	Same as above
						4	Same as above	Same as above
				Scan	Single	1	Same as above	Same as above
						4	Same as above	Same as above
Repeat	1				Same as above	Same as above		
	4				Same as above	Same as above		
Step mode	Select			Single	1	Same as software trigger mode	Same as software trigger mode	
					4	Same as above	Same as above	
				Repeat	1	Same as above	Same as above	
					4	Same as above	Same as above	
	Scan		Single	1	Same as above	Same as above		
				4	Same as above	Same as above		
Repeat	1		Same as above	Same as above				
	4		Same as above	Same as above				

32. USB2.0

This LSI includes 1 channel USB2.0 OTG/DRD(Host/Function) interface and 1 channel USB2.0 Host interface.

This section describes the overview of USB2.0 and USB2.0 PHY control.

The detail function of USB2.0 Host controller and the common function both Host module and Function module are described in **Section 32A, USB 2.0 Host Module**.

The detail function of USB2.0 Function controller is described in **Section 32B, USB 2.0 Function Module**.

32.1 Features

This interface complies the following specifications.

- Universal Serial Bus Specification Revision 2.0
- On-The-Go and Embedded Host Supplement to the USB Revision 2.0 Specification Revision 2.0 plus errata and ecn*¹
- Enhanced Host Controller Interface (EHCI) Specification for Universal Serial Bus Revision 1.0
- EHCI v1.1 Addendum*²
- Open Host Controller Interface (OHCI) Specification for USB Release 1.0a
- Battery Charging Specification Revision 1.2*³

Note 1. Session Request Protocol(SRP) and Host Negotiation Protocol(HNP) are not supported.

Note 2. Some EHCI v1.1 feature are not supported. (Refer to **Section 32A, USB 2.0 Host Module** for detail)

Note 3. DCP (Dedicated Charging Port) is not supported as downstream port.

32.1.1 Ch0: USB2.0 OTG/DRD(Host/Function) interface

The following table shows features of this interface.

Table 32.1 Ch0: USB2.0 OTG/DRD(Host/Function) interface features

Function	Description
Host mode	<ul style="list-style-type: none"> • Support mode: High-Speed(480Mbps)/Full-Speed(12Mbps)/Low-Speed(1.5Mbps) • Support Isochronous/Interrupt/Control/Bulk transfer modes • Support Isochroous/Interrupt high bandwidth transfer
Function mode	<ul style="list-style-type: none"> • Support mode: High-Speed(480Mbps)/Full-Speed(12Mbps) • Isochronous/Interrupt/Control/Bulk transfer • Up to 10 ch PIPE (includes default control PIPE)
Other functions	<ul style="list-style-type: none"> • OTG function (Rev2.0) • Battery Charging function • DRD(Dual-Role-Device) function (Static switch between Host and Function)

32.1.2 Ch1: USB2.0 HOST interface

The following table shows features of this interface.

Table 32.2 Ch1: USB2.0 Host interface function features

Features	Description
Host mode	<ul style="list-style-type: none"> • Support mode: High-Speed(480Mbps)/Full-Speed(12Mbps)/Low-Speed(1.5Mbps) • Support Isochronous/Interrupt/Control/Bulk transfer modes • Support Isochronous/Interrupt high bandwidth transfer
Other function	<ul style="list-style-type: none"> • Battery Charging function

32.1.3 Block Diagram

The block diagram of USB interface is as follows.

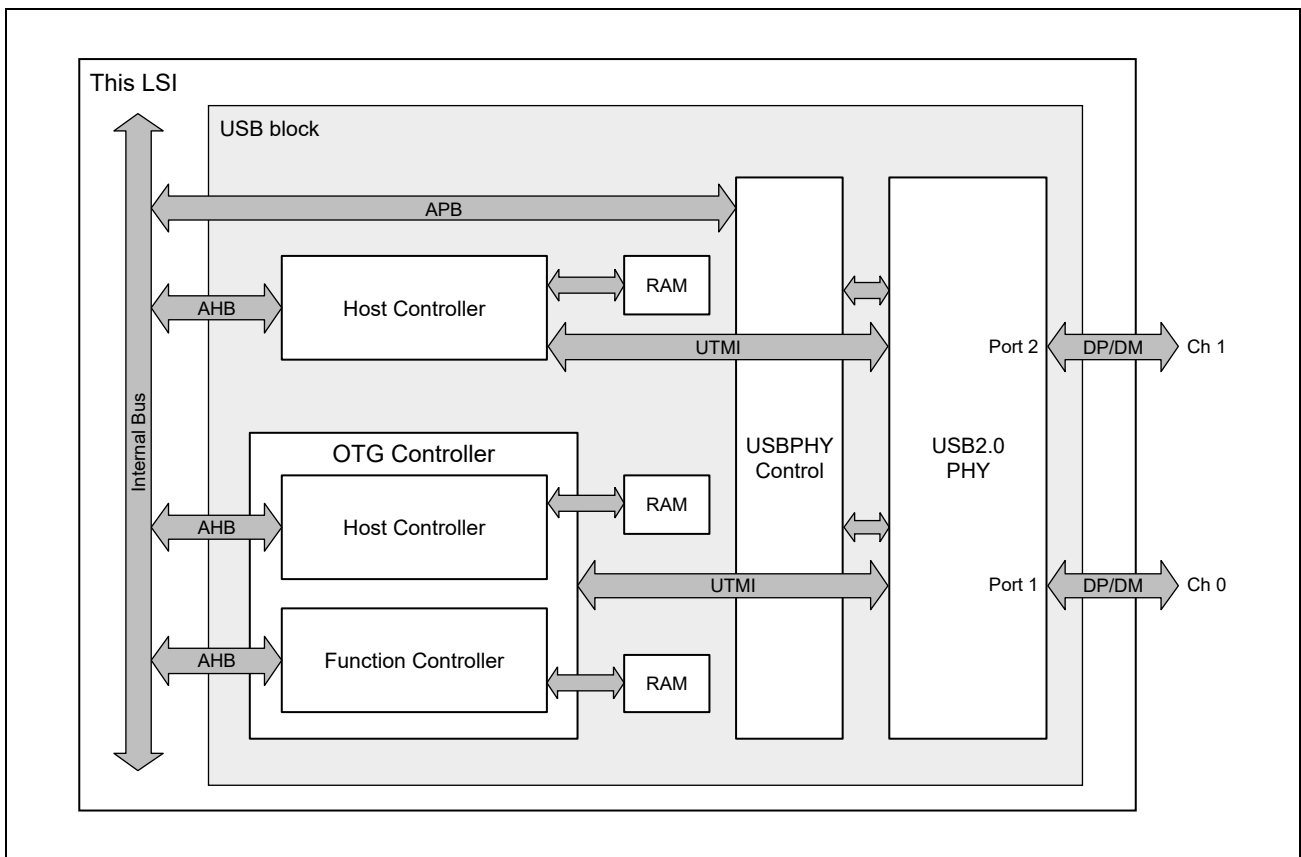

Figure 32.1 USB interface block diagram

32.1.4 External signal pins

The following table shows external signal pins for USB block.

Table 32.3 External signal pins

Name	I/O	Description	Active Level	Initial value	Handling in not used
USB0_DP	—	USB data pin Data+ (Ch0)	—	—	Open*1
USB0_DM	—	USB data pin Data- (Ch0)	—	—	Open*1
USB0_OVRCUR	I	Over current detection input (Ch0)	L	—	Pull-Up
USB0_VBUSEN	O	VBUS output enable (Ch0)	H	0b	Open
USB0_VBUSIN	I	Peripheral VBUS input (Ch0)	H	—	Pull-Down
USB0_OTG_EXICEN	O	External power IC control (Ch0)	H	0b	Open
USB0_OTG_ID	I	OTG ID input (Ch0)	—	—	Pull-Down
USB1_DP	—	USB data pin Data+ (Ch1)	—	—	Open*1
USB1_DM	—	USB data pin Data- (Ch1)	—	—	Open*1
USB1_OVRCUR	I	Over current detection input (Ch1)	L	—	Pull-Up
USB1_VBUSEN	O	VBUS output enable (Ch1)	H	0b	Open

Note 1. When it is not used permanently, connect to GND via a resistor of 10kΩ.

32.1.5 Power and GND pins

The following table shows Power and GND pins for USB block.

Table 32.4 Power and GND pins

Name	Description
USB_VDD18	Internal Regulator Power (1.8V), HS receiver power (1.8V)
USB_VDD33	IO power (3.3V)
USB_RREF	Reference voltage
VSS	GND

32.1.6 Interrupt

The following table shows interrupt list for USB block.

Table 32.5 USB interrupt

Name	Description	Active Level	Type
U2H0_INT	USB2.0 Host AHB Interrupt (Ch0)	H	Level-Sensitive
U2H0_OHCI_INT	USB2.0 Host OHCI Interrupt (Ch0)	H	Level-Sensitive
U2H0_EHCI_INT	USB2.0 Host EHCI Interrupt (Ch0)	H	Level-Sensitive
U2H0_WAKEON_INT	USB2.0 Host EHCI Wakeup Interrupt (Ch0)	H	Level-Sensitive
U2H0_OBINT	USB2.0 Host OTG and Battery Charging Interrupt (Ch0)	H	Level-Sensitive
U2H1_INT	USB2.0 Host AHB Interrupt (Ch1)	H	Level-Sensitive
U2H1_OHCI_INT	USB2.0 Host OHCI Interrupt (Ch1)	H	Level-Sensitive
U2H1_EHCI_INT	USB2.0 Host EHCI Interrupt (Ch1)	H	Level-Sensitive
U2H1_WAKEON_INT	USB2.0 Host EHCI Wakeup Interrupt (Ch1)	H	Level-Sensitive
U2H1_OBINT	USB2.0 Host OTG and Battery Charging Interrupt (Ch1)	H	Level-Sensitive
U2P_IXL_INT	USB2.0 Function controller Interrupt (Ch0)	H	Edge-Triggered
U2P_INT_DMA[1:0]	USB2.0 Function controller DMA transaction complete interrupt (Ch0)	H	Level-Sensitive
U2P_INT_DMAERR	USB2.0 Function controller DMA error response interrupt (Ch0)	H	Level-Sensitive

32.2 Register Configuration

32.2.1 Host controller Register

Refer to the **Section 32A, USB 2.0 Host Module**.

32.2.2 Function controller Register

Refer to the **Section 32B, USB 2.0 Function Module**.

32.2.3 USBPHY Control Register

USBPHY Control Register mainly controls reset and power down of the USB/PHY.

Base Address: H'0_11C4_0000 (AX45MP Address Space)

The following table shows USBPHY Control Register list.

Prohibit to write undefined area.

Table 32.6 USBPHY Control Register List

Register Name	Abbreviation	R/W	Initial Value	Address	Access Size
Reset register	RESET	R/W	H'0000_0133	H'000	32
Clock control register	UCLKCTL	R/W	H'0340_0303	H'018	32
Direct power down setting register	UDIRPD	R/W	H'0000_0000	H'01C	32
VBUSEN control register	VBENCTL	R/W	H'0000_0000	H'03C	32
Connection control register	CON_CTRL	R/W	H'0000_0000	H'020	32
Clock status register	CLK_STAT	R	H'0000_0000	H'104	32

32.3 Register Descriptions

32.3.1 Reset register (RESET)

This register controls USB/PHY reset.

Bit	31	30	29	28	27	26	25	24	23	22	21	20	19	18	17	16
	—	—	—	—	—	—	—	—	—	—	—	—	—	—	—	—
Initial Value	0	0	0	0	0	0	0	0	0	0	0	0	0	0	0	0
R/W	R	R	R	R	R	R	R	R	R	R	R	R	R	R	R	R
Bit	15	14	13	12	11	10	9	8	7	6	5	4	3	2	1	0
	—	—	—	sel_pll reset	—	—	—	pllreset	—	—	sel_p2 reset	sel_p1 reset	—	—	phyrst_2	phyrst_1
Initial Value	0	0	0	0	0	0	0	1	0	0	1	1	0	0	1	1
R/W	R	R	R	R/W	R	R	R	R/W	R	R	R/W	R/W	R	R	R/W	R/W

Bit	Bit Name	Initial Value	R/W	Description
31 to 13	—	All 0	R	Reserved Whenever it is read, 0 is read. The written value will be ignored.
12	sel_pllreset	0	R/W	Select USB/PHY PLL reset 1: register (by bit8: pllreset) 0: control by host controller (Ch0)
11 to 9	—	All 0	R	Reserved Whenever it is read, 0 is read. The written value will be ignored.
8	pllreset	1	R/W	PLL reset 1: PLL reset 0: deassert PLL reset
7, 6	—	All 0	R	Reserved Whenever it is read, 0 is read. The written value will be ignored.
5	sel_p2reset	1	R/W	Select USB/PHY Port2 reset 1: register(phyrst_2) 0: Control by host controller (Ch1)
4	sel_p1reset	1	R/W	Select USB/PHY Port1 reset 1: register(phyrst_1) 0: Control by host controller (Ch0)
3, 2	—	All 0	R	Reserved Whenever it is read, 0 is read. The written value will be ignored.
1	phyrst_2	1	R/W	USB/PHY reset (Port2) 1: USB/PHY reset 0: deassert USB/PHY reset Only when sel_p2reset=1, this bit is valid.
0	phyrst_1	1	R/W	USB/PHY reset (Port1) 1: USB/PHY reset 0: deassert USB/PHY reset Only when sel_p1reset=1, this bit is valid.

32.3.2 Clock control register (UCLKCTL)

This register controls USB/PHY clock.

Bit	31	30	29	28	27	26	25	24	23	22	21	20	19	18	17	16
	—	—	—	sel_sleepm	—	—	sleepm_2	sleepm_1	—	—	—	—	—	—	—	—
Initial Value	0	0	0	0	0	0	1	1	0	1	0	0	0	0	0	0
R/W	R	R	R	R/W	R	R	R/W	R/W	R	R	R	R	R	R	R	R
Bit	15	14	13	12	11	10	9	8	7	6	5	4	3	2	1	0
	—	—	—	sel_suspendm	—	—	suspendm_2	suspendm_1	—	—	—	—	—	—	—	—
Initial Value	0	0	0	0	0	0	1	1	0	0	0	0	0	0	1	1
R/W	R	R	R	R/W	R	R	R/W	R/W	R	R	R	R	R	R	R	R

Bit	Bit Name	Initial Value	R/W	Description
31 to 29	—	All 0	R	Reserved Whenever it is read, 0 is read. The written value will be ignored.
28	sel_sleepm	0	R/W	Select SLEEP control 1: register (controlled by bit 24: sleepm_1 and bit 25: sleepm_2) 0: Control by controller
27, 26	—	All 0	R	Reserved Whenever it is read, 0 is read. The written value will be ignored.
25	sleepm_2	1	R/W	Sleep control (Port2) 1: Normal mode 0: Sleep mode
24	sleepm_1	1	R/W	Sleep control (Port1) 1: Normal mode 0: Sleep mode
23	—	0	R	Reserved Whenever it is read, 0 is read. The written value will be ignored.
22	—	1	R	Reserved When read, the initial value is read. When writing, be sure to write the initial value. Operation is not guaranteed if a value other than the initial value is written.
21, 20	—	All 0	R	Reserved When read, the initial value is read. When writing, be sure to write the initial value. Operation is not guaranteed if a value other than the initial value is written.
19, 18	—	All 0	R	Reserved Whenever it is read, 0 is read. The written value will be ignored.
17, 16	—	All 0	R	Reserved When read, the initial value is read. When writing, be sure to write the initial value. Operation is not guaranteed if a value other than the initial value is written.
15, 14	—	All 0	R	Reserved Whenever it is read, 0 is read. The written value will be ignored.
13	—	0	R	Reserved When read, the initial value is read. When writing, be sure to write the initial value. Operation is not guaranteed if a value other than the initial value is written.
12	sel_suspendm	0	R/W	Select SUSPEND control 1: register (controlled by bit 8: suspendm_1 and bit 9: suspendm_2) 0: control by controller
11, 10	—	All 0	R	Reserved Whenever it is read, 0 is read. The written value will be ignored.

Bit	Bit Name	Initial Value	R/W	Description
9	suspend_2	1	R/W	Suspend control (Port2) 0: Suspend mode 1: Normal mode
8	suspend_1	1	R/W	Suspend control (Port1) 0: Suspend mode 1: Normal mode
7 to 5	—	All 0	R	Reserved Whenever it is read, 0 is read. The written value will be ignored.
4	—	0	R	Reserved When read, the initial value is read. When writing, be sure to write the initial value. Operation is not guaranteed if a value other than the initial value is written.
3, 2	—	All 0	R	Reserved Whenever it is read, 0 is read. The written value will be ignored.
1, 0	—	All 1	R	Reserved When read, the initial value is read. When writing, be sure to write the initial value. Operation is not guaranteed if a value other than the initial value is written.

32.3.3 Direct power down setting register (UDIRPD)

This register controls USB/PHY direct power down.

Bit	31	30	29	28	27	26	25	24	23	22	21	20	19	18	17	16
	—	—	—	—	—	—	—	—	—	—	—	—	—	—	—	—
Initial Value	0	0	0	0	0	0	0	0	0	0	0	0	0	0	0	0
R/W	R	R	R	R	R	R	R	R	R	R	R	R	R	R	R	R
Bit	15	14	13	12	11	10	9	8	7	6	5	4	3	2	1	0
	—	—	—	—	—	—	—	—	—	—	—	sel_udirpd	—	—	—	dirpd
Initial Value	0	0	0	0	0	0	0	0	0	0	0	0	0	0	0	0
R/W	R	R	R	R	R	R	R	R	R	R	R	R/W	R	R	R	R/W

Bit	Bit Name	Initial Value	R/W	Description
31 to 5	—	All 0	R	Reserved Whenever it is read, 0 is read. The written value will be ignored.
4	sel_udirpd	0	R/W	Select dirpd control 1: register (dirpd) 0: Control by host controller (Ch0)
3 to 1	—	All 0	R	Reserved Whenever it is read, 0 is read. The written value will be ignored.
0	dirpd	0	R/W	Power down control to reduce the power consumption of the USB/PHY when not using the USB function. 0: Normal operation 1: Power save

32.3.4 VBUSEN control register (VBENCTL)

Bit	31	30	29	28	27	26	25	24	23	22	21	20	19	18	17	16
	—	—	—	—	—	—	—	—	—	—	—	—	—	—	—	—
Initial Value	0	0	0	0	0	0	0	0	0	0	0	0	0	0	0	0
R/W	R	R	R	R	R	R	R	R	R	R	R	R	R	R	R	R
Bit	15	14	13	12	11	10	9	8	7	6	5	4	3	2	1	0
	—	—	—	—	—	—	—	—	—	—	—	—	—	—	—	vbus_sel_0
Initial Value	0	0	0	0	0	0	0	0	0	0	0	0	0	0	0	0
R/W	R	R	R	R	R	R	R	R	R	R	R	R	R	R	R	R/W

Bit	Bit Name	Initial Value	R/W	Description
31 to 2	—	All 0	R	Reserved Whenever it is read, 0 is read. The written value will be ignored.
1	—	0	R	Reserved When read, the initial value is read. When writing, be sure to write the initial value. Operation is not guaranteed if a value other than the initial value is written.
0	vbus_sel_0	0	R/W	Select VBUSEN control 1: VBOUT bit of the VBUS Control register. 0: Port Power bit of the EHCI/OHCI Operational register.

32.3.5 Connection control register (CON_CTRL)

This register controls USB/PHY connection

Bit	31	30	29	28	27	26	25	24	23	22	21	20	19	18	17	16
	—	—	—	—	—	—	—	—	—	—	—	—	—	—	—	—
Initial Value	0	0	0	0	0	0	0	0	0	0	0	0	0	0	0	0
R/W	R	R	R	R	R	R	R	R	R	R	R	R	R	R	R	R
Bit	15	14	13	12	11	10	9	8	7	6	5	4	3	2	1	0
	—	—	—	—	—	—	—	—	—	—	—	sel_connect	—	—	connect_2	connect_1
Initial Value	0	0	0	0	0	0	0	0	0	0	0	0	0	0	0	0
R/W	R	R	R	R	R	R	R	R	R	R	R	R/W	R	R	R/W	R/W

Bit	Bit Name	Initial Value	R/W	Description
31 to 5	—	All 0	R	Reserved Whenever it is read, 0 is read. The written value will be ignored.
4	sel_connect	0	R/W	Select USB connection notification control 1: register (controlled by bit0: connect_0 and bit1: connect_1) 0: Control by host controller
3, 2	—	All 0	R	Reserved Whenever it is read, 0 is read. The written value will be ignored.
1	connect_2	0	R/W	Notice of USB connection (port2) Used to notify UTM + core of USB connection status 0: USB not connected (single end receiver disabled) 1: USB not connected (single end receiver enabled)
0	connect_1	0	R/W	Notice of USB connection (port1) Used to notify UTM + core of USB connection status 0: USB not connected (single end receiver disabled) 1: USB not connected (single end receiver enabled)

32.3.6 Clock status register (CLK_STAT)

This register shows USB/PHY clock status.

Bit	31	30	29	28	27	26	25	24	23	22	21	20	19	18	17	16
	—	—	—	—	—	—	—	—	—	—	—	—	—	—	—	—
Initial Value	0	0	0	0	0	0	0	0	0	0	0	0	0	0	0	0
R/W	R	R	R	R	R	R	R	R	R	R	R	R	R	R	R	R
Bit	15	14	13	12	11	10	9	8	7	6	5	4	3	2	1	0
	—	—	—	—	—	—	—	—	—	frclk60 lock	frclk48 lock	phy lock	—	—	plllock_ 2	plllock_ 1
Initial Value	0	0	0	0	0	0	0	0	0	0	0	0	0	0	0	0
R/W	R	R	R	R	R	R	R	R	R	R	R	R	R	R	R	R

Bit	Bit Name	Initial Value	R/W	Description
31 to 7	—	All 0	R	Reserved Whenever it is read, 0 is read. The written value will be ignored.
6	frclk60_lock	0	R	FRCLK60 LOCK status 0: UNLOCK 1: LOCK
5	frclk48_lock	0	R	FRCLK48 LOCK status 0: UNLOCK 1: LOCK
4	phylock	0	R	PHY PLL LOCK Status (Transceiver) 0: UNLOCK 1: LOCK
3, 2	—	All 0	R	Reserved Whenever it is read, 0 is read. The written value will be ignored.
1	plllock_2	0	R	PLL LOCK status (port2) 0: UNLOCK 1: LOCK
0	plllock_1	0	R	PLL LOCK status (port1) 0: UNLOCK 1: LOCK

32.4 Operation

32.4.1 USB/PHY Initialization

In the initial state, the reset of USB/PHY Port1 and Port2 is controlled by the register in the USBPHY Control Register, and the reset is asserted, so the control is switched to controller by the following initialization.

Also, in the initial state, the USB/PHY PLL Reset is controlled by the Host Controller in the OTG Controller, but it needs to be switched to controlled by the USBPHY Control Register.

- **Initialization when starting only Port1 of USB/PHY (when Port2 is not used)**

Write H'0000_1133 to the reset register (RESET) of USBPHY Control Register, and then write H'0000_1022 to release the reset.

(By the above register settings, USBPHY Control Register controls the PLL Reset and the reset is released.

Port1 of USB/PHY is controlled by Host Controller, and Port2 is reset by USBPHY Control Register.)

- **Initialization when starting only Port2 of USB/PHY (when Port1 is not used)**

Write H'0000_1133 to the reset register (RESET) of USBPHY Control Register, and then write H'0000_1011 to release the reset.

(By the above register settings, USBPHY Control Register controls the PLL Reset and the reset is released.

USB/PHY Port1 is reset by USBPHY Control Register, and port2 is controlled by Host Controller.)

- **Initialization when starting both Port1 and Port2 of USB/PHY**

Write H'0000_1133 to the reset register (RESET) of USBPHY Control Register, and then write H'0000_1000 to release the reset.

(By the above register settings, USBPHY Control Register controls the PLL Reset and the reset is released.

USB/PHY Port1 is controlled by the Host Controller, and Port2 is controlled by the Host Controller.)

The common setting sequence both Host mode and Function mode including USB/PHY initialization is described in **Section 32A.9.1, Host/Peripheral Common Setting Sequence.**

32.4.2 Handling of permanently unused pin

Take the following measures when USB interface is not used permanently.

32.4.2.1 USB/PHY related pins

- When both Port1 and Port2 are unused

Take the following measures for the USB pins and power supply.

- Connect the USB0_DP/DM and USB1_DP/DM to GND via a resistor of 10kΩ.
- Set the RREF to Open.
- Connect USB_VDD18 to a 1.8V power supply. However, there is no need to separate the digital and analog power supplies.
- Connect USB_VDD33 to GND.
- Connect VSS to GND.

Also, perform the following control with software.

- Set the direct power down (via UDIRPD register). See 34.3.3 Direct power down for more information.

- When either Port1 or Port2 is unused

Supply all power.

Since USB_VDD18 / USB_VDD33 are common to 2 Port PHY, it is necessary to supply power even when one of the ports is not in use.

Make the following settings for unused port.

- Apply Port reset:
 - Apply reset to unused USB/PHY port by controlling the Reset register (RESET).
 - Set sel_p1reset=1 and phyrst_1=1 when USB/PHY Port1 is unused.
 - Set sel_p2reset=1 and phyrst_2=1 when USB/PHY Port2 is unused.
- Power down setting:
 - Set power down setting to unused USB/PHY port by controlling the Clock control register (UCLKCTL).
 - Set sel_suspendm=1 and suspendm_1=0 when USB/PHY Port1 is unused.
 - Set sel_suspendm=1 and suspendm_2=0 when USB/PHY Port2 is unused.
- Single-ended receiver stop:
 - Stop single-ended receiver of unused USB/PHY port by controlling the Connection control register (CON_CTRL).
 - Set sel_connect=1 and connect_1=0 when USB/PHY Port1 is unused.
 - Set sel_connect=1 and connect_2=0 when USB/PHY Port2 is unused.

32.4.2.2 Handling of USB controller related pins

- When Host controller is unused

The USB0_VBUSEN pin leaves open and fix the USB0_OVRCUR pin to 1 when USB/PHY port1 is unused.

The USB1_VBUSEN pin leaves open and fix the USB1_OVRCUR pin to 1 when USB/PHY port2 is unused.

- Function controller is unused

Fix the USB0_VBUSIN pin to 0 when USB/PHY port1 is unused.

32.4.3 Direct power down (DIRPD)

By directly controlling the power down signal of the USB/PHY with the USBPHY Control register, the USB/PHY can be put into a low power state regardless of the state of the controller.

When set to the direct power down state, all USB/PHY functions including the PLL will be stopped. Direct power down can only be used when the USB/PHY is unused (means both ports are unused).

Follow the procedure below to switch to / return to the direct power down mode.

For details on the USBPHY Control Register reset register and direct power down setting register used in the procedure below, refer to **Section 32.3.1, Reset register (RESET)** and **Section 32.3.3, Direct power down setting register (UDIRPD)**, respectively.

32.4.3.1 Enter to Direct power down mode

Follow the steps below to switch to direct power down mode.

- (1) USB operation stop

Stop the operation of USB.

- (2) Assert the direct power down signal.

It is asserted by setting H'0000_0010 in the direct power-down setting register (UDIRPD) and then setting H'0000_0011.

There are no timing restrictions when transitioning to direct power down. Immediately after setting, it shifts to power down mode.

32.4.3.2 Resume from Direct power down mode

Follow the steps below to recover from the direct power down mode.

- (1) Assert a USB/PHY PLL reset.

The PLL reset is asserted by setting 1 to sel_pllreset bit of the Reset register (RESET) and then setting 1 to pllreset bit.

The reset period should be 1 μ s or more.

- (2) De-assert direct power down signal

Negate the direct power down signal after continuing to assert the PLL reset for more than 1 μ s. It is negated by setting H'0000_0010 in the direct power down setting register (UDIRPD) and then setting H'0000_0000.

After negating the direct power down signal, keep asserting the PLL reset for at least 1 μ s.

- (3) De-assert USB/PHY PLL reset

After negating the direct power down signal, continue to assert the PLL reset for 1 μ s or more, and then negate the PLL reset.

The PLL reset is negated by clearing the pllreset bit in the reset register (RESET) and then clearing the sel_pllreset.

The timing chart when returning from the direct power down is shown below.

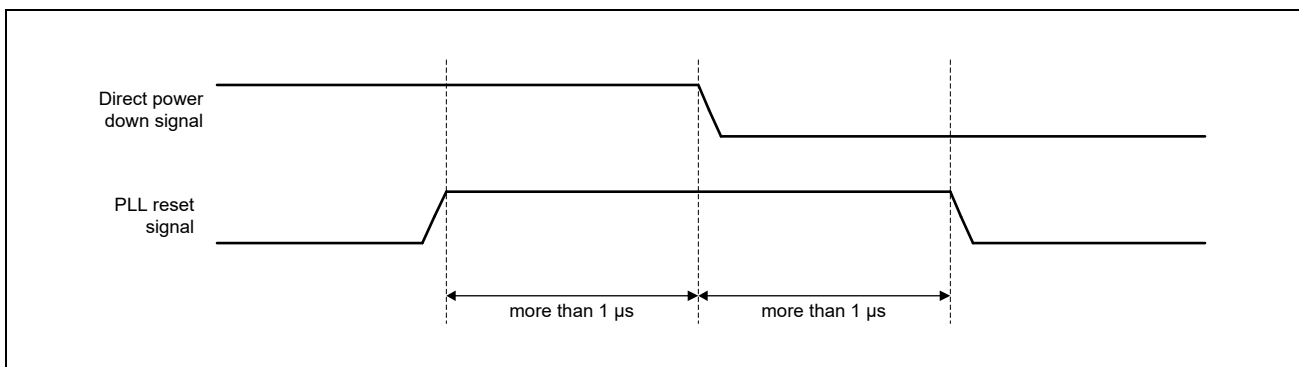

Figure 32.2 Resume from Direct power down mode

32.5 Usage Notes

32.5.1 Precautions in power down mode

When USB interface is unused, it can be set to power-down mode by register setting. For the setting, refer to **Section 32.3.3, Direct power down setting register (UDIRPD)**.

The precautions for power down mode are as follows.

- Once enter to power down, do not access the interface.
- Move to the power-down state after the USB is in unused state. If USB interface moves power-down state while it is operating, current may continue to flow to the USB side and it may damage device.

32A. USB 2.0 Host Module

32A.1 Overview

32A.1.1 Overview

This LSI has two USB 2.0 host/function modules. For each module, you can switch between the host mode and the peripheral mode by specifying the UCOM register setting. This section describes the circuits that are common to both modes, and the host controller itself.

32A.1.2 Features

This module has the following features:

Function	Description
Host function	<ul style="list-style-type: none"> Supporting high-speed (480 Mbps), full-speed (12 Mbps), and low-speed (1.5 Mbps) transfers Compliant with Open Host Controller Interface (OHCI) Specification for USB Revision 1.0a Compliant with Enhanced Host Controller Interface (EHCI) Specification for USB Revision 1.1*¹
Other functions	<ul style="list-style-type: none"> Battery charging (compliant with Battery Charging Specification Revision 1.2)*² Dual-role-device function (static switching between the USB host and USB peripheral functions)

Note 1. Some functions (specifications) are not supported.

Note 2. The setting for battery charging is handled by the host controller even if the function controller is selected.
This LSI does not support DCP (Dedicated Charging Port) as a Downstream Port.

32A.1.2.1 EHCI v1.1 functions

Conventional host controller modules comply with EHCI Specification Revision.1.0. Meanwhile, this module supports the additional functions listed below to comply with EHCI v1.1 Addendum.

Note, however, that this module supports only the functions marked with a circle “✓” in the table below.

Function Name	Support
Per-Port Change Events	✓
Shorter Periodic Frame List	✓
Hardware Prefetching	—
Link Power Management (LPM)	✓

Of the three features to support, the registers associated with “Per-Port Change Events” and “Shorter Periodic Frame List” are listed below. For more information on each register, refer to the appropriate register specification of the **Section 32A.2, Register Descriptions**.

With regard to “Link Power Management (LPM)”, it is described in **Section 32A.1.2.2, Link Power Management (LPM) function**.

Table 32A.1 Per-Port Change Events

Relevant register	Relevant bit	Attribute	Function	
HCCPARAMS (offset: H'108)	bit 18	Per-Port Change Event Capability	R	This bit indicates to support this function. This bit is fixed to 1b.
USBCMD (offset: H'120)	bit 15	Per-Port Change Events Enable	R/W	Per-Port event notification setting. Writing 1b to this bit enables the Per-Port event notification function.
USBSTS (offset: H'124)	bit 16	Port-1 Change Detect	R/W(1)	If a port-1 change event is detected, 1b is written to this bit.
USBINTR (offset: H'128)	bit 16	Port-1 Change Event Enable	R/W	Enable/Disable setting of the above “port-1 Change Detect” field. To reflect the port event on the above field for the port, set corresponding bit to 1b.

Table 32A.2 Shorter Periodic Frame List

Relevant register	Relevant bit	Attribute	Function	
HCCPARAMS (offset: H'108)	bit 19	32-Frame Periodic List Capability	R	This bit indicates to support this function. This bit is fixed to 1b.
USBCMD (offset: H'120)	bit[3:2]	Frame List Size	R/W	This bit determines the Frame List Size. To determine 32-frames, set this field 11b.

32A.1.2.2 Link Power Management (LPM) function

This module supports the power management function conforming to “USB 2.0 Link Power Management Addendum to the Universal Serial Bus v2.0 Specification” (abbreviated as LPM).

When the peripheral device which supports LPM function is connected to this module, the device can be moved to suspend state faster than conventional by using LPM function.

*In using LPM function: 8 to 10 μ s

The relevant registers are listed in the following. Refer to the appropriate register specification of each register detail in **Section 32A.2, Register Descriptions**.

Relevant register	Relevant bit		Attribute	Function
HCCPARAMS (offset: H'108)	bit 17	Link Power Management Capability	R	This bit indicates to support this function. This bit is fixed to 1b.
USBCMD (offset: H'120)	bit[27:24]	Host-Initiated Resume Duration	R/W	The minimum duration time of K-state drive in resume from LPM state.
PORTSC1 (offset: H'164)	bit[31:25]	Device Address [7:0]	R/W	The device address of the destination of LPM Token. In using LPM function, this setting is needed. Set the address of the device connected to the corresponding port before sending LPM Token.
	bit[24:23]	Suspend Status [1:0]	R	The device response to LPM Token.
	bit 9	Suspend using L1	R/W	In using LPM function, set this bit 1b.
	bit 7	Suspend	R/W	When this bit is set to 1b this module starts LPM Token transaction, in condition of “Suspend using L1 bit = 1b” and “Device address field = H'000”.
PORT_LPM_CTR1 (offset: H'320)	bit[7:4]	NYET_RETRY_CNT_P1[3:0]	R/W	The number of retry for NYET response of device in LPM transaction.
	bit 3	REMOTEWAKE_EN_P1	R/W	Setting of LPM RemoteWakeup permission. 0b: permitted (default) 1b: not permitted
	bit 2	SLEEP_INT_EN_P1	R/W	In LPM transaction, setting to generate an interrupt or not when received a response other than ACK. 0b: not to generate an interrupt (default) 1b: to generate an interrupt
	bit 1	RETRY_ENABLE_NYET_P1	R/W	In LPM transaction, setting to the host behavior when received NYET response from the device. 0b: not to Retry (default) 1b: to Retry
	bit 0	HIRD_SEL_P1	R/W	Setting the duration time of the K-state drive, in resume of LPM state.

32A.1.2.3 OTG function

Detects changing of the USB0_OTG_ID pin by U2H0_OBINT interrupt and switches the Host/Function role. Confirm the IDCHG_STA bit of **Section 32A.2.4.5(2), OTG-BC Interrupt Status Register** and the IDMON bit of **Section 32A.2.4.5(5), Line Control Port 1 Register**.

Host/Function role switching is performed by the OTG_PERI bit of **Section 32A.2.4.5(1), Common Control Register**.

OTG_PERI bit
0 : Host mode
1 : Function mode (Only CH0 can be set)

32A.1.2.4 Battery-charging function

The Control and monitoring of the Battery Charging I/F of the USBPHY is set in the UCOM register of this module. The detail of the UCOM register, refer to **Section 32A.2.4.5, UCOM Register**.

32A.1.2.5 Suspend extension function

This module implements the following two suspend extension functions to reduce power consumption by stopping PLL of USBPHY.

The detail of the register, refer to **Section 32A.2.4.4(6), Suspend Control Register**.

[Relevant register]

Suspend Control Register (offset: H'308)

[Functional specification]

Function	Function	Relevant bit	Relevant bit
[1]	Function to assert USBPHY SUSPENDM by asserting the Suspend bit in the OHCI/EHCI Operational Register	bit 31	SUSPENDM_ENABLE
[2]	Function to forcibly assert USBPHY SUSPENDM	bit 0	GLOBAL_SUSPENDM_P1

32A.1.3 Support of USB-Related Specifications

USB-Related Specification or Function		Support	
Host function	High Speed	Bulk IN/OUT transfer	✓
		Control IN/OUT transfer	✓
		Isochronous IN/OUT transfer	✓
		Isochronous Highband transfer	✓
		Interrupt IN/OUT transfer	✓
	Full Speed	Bulk IN/OUT transfer	✓
		Control IN/OUT transfer	✓
		Isochronous IN/OUT transfer	✓
		Interrupt IN/OUT transfer	✓
	Low Speed	Control IN/OUT transfer	✓
		Interrupt IN/OUT transfer	✓
No. of hub connection stages	HS: 5 stages	✓	
	FS: 5 stages	✓	
Support of EHCI V1.1	Hardware Prefetching	×	
	Link Power Management	✓	
	Per-Port Change Events	✓	
	Shorter Periodic Frame List	✓	
Battery-charging function (hereafter called the "BC function")		✓	
Dual role device * Function to statically switch between the host and peripheral modes		✓	

Remarks: ✓: support
 ×: no support

32A.2 Register Descriptions

32A.2.1 Register Attributes

Table 32A.3 Register Attributes

Register Attribute	Description
R/W	Register bits can be read and written.
R/W(1)	Register bits can be read. A clear bit may be set by writing "1"; writing 0 to R/W(1) bits has no effect.
R/W(0)	Register bits can be read. A clear bit may be set by writing "0"; writing 1 to R/W(0) bits has no effect.
R	Register bits can only be read.
W	Register bits can only be written.
Reserved	Reserved bits are Read Only field.

32A.2.2 Base Address

Table 32A.4 Base Addresses for Each Channel of the USB Host Module

Channel	Base Address
0	H'0_11C5_0000 (AX45MP Address Space)
1	H'0_11C7_0000 (AX45MP Address Space)

32A.2.3 Register Overview

Register Name	Abbreviated Name	R/W	Initial Value	Offset Address	Access Size	Remarks	
HcRevision	HcRevision	R	H'0000_0000	H'000	32	OHCI Operation Registers	
HcControl	HcControl	R/W	H'0000_0000	H'004	32		
HcCommandStatus	HcCommandStatus	R/W	H'0000_0000	H'008	32		
HcInterruptStatus	HcInterruptStatus	R/W	H'0000_0000	H'00C	32		
HcInterruptEnable	HcInterruptEnable	R/W	H'0000_0000	H'010	32		
HcInterruptDisable	HcInterruptDisable	R/W	H'0000_0000	H'014	32		
HcHCCA	HcHCCA	R/W	H'0000_0000	H'018	32		
HcPeriodCurrentED	HcPeriodCurrentED	R	H'0000_0000	H'01C	32		
HcControlHeadED	HcControlHeadED	R/W	H'0000_0000	H'020	32		
HcControlCurrentED	HcControlCurrentED	R/W	H'0000_0000	H'024	32		
HcBulkHeadED	HcBulkHeadED	R/W	H'0000_0000	H'028	32		
HcBulkCurrentED	HcBulkCurrentED	R/W	H'0000_0000	H'02C	32		
HcDoneHead	HcDoneHead	R	H'0000_0000	H'030	32		
HcFmInterval	HcFmInterval	R/W	H'0000_2EDF	H'034	32		
HcFmRemaining	HcFmRemaining	R	H'0000_2EDF	H'038	32		
HcFmNumber	HcFmNumber	R	H'0000_0000	H'03C	32		
HcPeriodicStart	HcPeriodicStart	R/W	H'0000_0000	H'040	32		
HcLSThreshold	HcLSThreshold	R/W	H'0000_0628	H'044	32		
HcRhDescriptorA	HcRhDescriptorA	R/W	H'0F00_0901	H'048	32		
HcRhDescriptorB	HcRhDescriptorB	R/W	H'0020_0000	H'04C	32		
HcRhStatus	HcRhStatus	R/W	H'0000_0000	H'050	32		
HcRhPortStatus1	HcRhPortStatus1	R/W	H'0000_0000	H'054	32		
HCIVERSION / CAPLENGTH	CAPL_VERSION	R	H'0110_0020	H'100	32		EHCI Capability Registers
HCSPARAMS	HCSPARAMS	R	H'0000_1191	H'104	32		
HCCPARAMS	HCCPARAMS	R	H'000E_0006	H'108	32		
HCSP_PORTROUTE	HCSP_PORTROUTE	R	H'0000_0000	H'10C	32		
USBCMD	USBCMD	R/W	H'0008_0B00	H'120	32	EHCI Operation Registers	
USBSTS	USBSTS	R/W	H'0000_1000	H'124	32		
USBINTR	USBINTR	R/W	H'0000_0000	H'128	32		
FRINDEX	FRINDEX	R/W	H'0000_0000	H'12C	32		
CTRLDSSEGMENT	CTRLDSSEGMENT	R	H'0000_0000	H'130	32		
PERIODICLISTBASE	PERIODICLISTBASE	R/W	H'0000_0000	H'134	32		
ASYNCLISTADDR	ASYNCLISTADDR	R/W	H'0000_0000	H'138	32		
CONFIGFLAG	CONFIGFLAG	R/W	H'0000_0000	H'160	32		
PORTSC1	PORTSC1	R/W	H'0000_2000	H'164	32		
INT_ENABLE	INT_ENABLE	R/W	H'0000_0000	H'200	32		AHB Registers
INT_STATUS	INT_STATUS	R/W	H'0000_0000	H'204	32		
AHB_BUS_CTR	AHB_BUS_CTR	R/W	H'0000_0000	H'208	32		
USBCTR	USBCTR	R/W	H'0000_0002	H'20C	32		

Register Name	Abbreviated Name	R/W	Initial Value	Offset Address	Access Size	Remarks
Register Enable/Clock Gating Control	REGEN_CG_CTRL	R/W	H'0000_0000	H'304	32	Core Defined Registers
Suspend Control	SPD_CTRL	R/W	H'0000_0000	H'308	32	
Suspend/Resume Timer Setting	SPD_RSM_TIMSET	R/W	H'01F4_03E8	H'30C	32	
Overcurrent Detection/Sleep Timer Setting	OC_SLP_TIMSET	R/W	H'0C83_0D40	H'310	32	
SBRN/FLADJ/PORTWAKECAP	SBRN_FLADJ_PW	R/W	H'0003_2020	H'314	32	
PORT_LPM_CTRL1	PORT_LPM_CTRL1	R/W	H'0000_0000	H'320	32	
Common Control	COMMCTRL	R/W	H'8000_0000	H'800	32	OTG/BC Module Control Register
OTG-BC Interrupt Status	OBINTSTA	R/W	H'0000_0001	H'804	32	OTG/BC Interrupt Status Register
OTG-BC Interrupt Enable	OBINTEN	R/W	H'0000_0000	H'808	32	OTG/BC Interrupt Enable Register
VBUS Control	VBCTRL	R/W	H'0001_0000	H'80C	32	OTG VBUS Control Register
Line Control Port 1	LINECTRL1	R/W	H'0000_0000	H'810	32	OTG USB Bus Control Register (Port 1)
BC Control Port 1	BCCTRL1	R/W	H'0300_0000	H'820	32	Battery Charging Control Register (Port 1)

32A.2.4 Description of Registers

32A.2.4.1 OHCI Operational Register

(1) HcRevision Register

Abbreviated name of register: HcRevision

Bit	31	30	29	28	27	26	25	24	23	22	21	20	19	18	17	16
	—	—	—	—	—	—	—	—	—	—	—	—	—	—	—	—
Initial Value	0	0	0	0	0	0	0	0	0	0	0	0	0	0	0	0
R/W	R	R	R	R	R	R	R	R	R	R	R	R	R	R	R	R
Bit	15	14	13	12	11	10	9	8	7	6	5	4	3	2	1	0
	—	—	—	—	—	—	—	—	Revision							
Initial Value	0	0	0	0	0	0	0	0	0	0	0	0	0	0	0	0
R/W	R	R	R	R	R	R	R	R	R	R	R	R	R	R	R	R

Bit	Bit Name	Initial Value	R/W	Description
31 to 8	—	All 0	R	Reserved The write value should always be 0.
7 to 0	Revision	All 0	R	This field indicates the version of HCI specifications implemented in this host controller module. Because this module conforms to OHCI standard 1.0a, H'10 is indicated.

(2) HcControl Register

Abbreviated name of register: HcControl

Bit	31	30	29	28	27	26	25	24	23	22	21	20	19	18	17	16
	—	—	—	—	—	—	—	—	—	—	—	—	—	—	—	—
Initial Value	0	0	0	0	0	0	0	0	0	0	0	0	0	0	0	0
R/W	R	R	R	R	R	R	R	R	R	R	R	R	R	R	R	R
Bit	15	14	13	12	11	10	9	8	7	6	5	4	3	2	1	0
	—	—	—	—	—	—	RWC	—	HCFS		BLE	CLE	IE	PLE	CBSR	
Initial Value	0	0	0	0	0	0	0	0	0	0	0	0	0	0	0	0
R/W	R	R	R	R	R	R	R/W	R	R/W	R/W	R/W	R/W	R/W	R/W	R/W	R/W

Bit	Bit Name	Initial Value	R/W	Description
31 to 10	—	All 0	R	Reserved The write value should always be 0.
9	RWC	0	R/W	Remote Wakeup Connected This bit indicates whether the host controller supports remote wakeup signaling. Software should set this bit to 1b in the initialization sequence if it is required to support remote wakeup. Note that this bit can be initialized at hardware reset only. 0b: The remote wakeup is not supported. 1b: The remote wakeup is supported
8	—	0	R	Reserved The write value should always be 0.
7, 6	HCFS	All 0	R/W	Host Controller Functional State This field indicates the operating state of the host controller. 00b: USB Reset 01b: USB Resume 10b: USB Operational 11b: USB Suspend When the state is changed to USB Operational, the host controller module starts SOF transmission at 1 ms boundary. This field is basically controlled by software, but it can be controlled by the host controller in the state of USB Suspend only. If the host controller (in the state of USB Suspend) detects a Remote Wakeup signal from the connecting device, the state in this field is changed to USB Resume. Note that the reset value of this field differs between hardware reset and software reset. Hardware reset: 00b (USB Reset) Software reset: 11b (USB Suspend)
5	BLE	0	R/W	BulkList Enable This bit sets whether the bulk list processing is performed for the next frame. The setting value of this bit is enabled from the next frame. When you correct the bulk list, this bit must be 0b. 0b: The processing of the Bulk list is disabled. 1b: The processing of the Bulk list is enabled
4	CLE	0	R/W	ControlList Enable This bit sets whether the control list processing is performed for the next frame. The setting value of this bit is enabled from the next frame. When you correct the control list, this bit must be 0b. 0b: The processing of the Control list is disabled. 1b: The processing of the Control list is enabled.

Bit	Bit Name	Initial Value	R/W	Description										
3	IE	0	R/W	<p>Isochronous Enable</p> <p>This bit sets whether the isochronous ED processing is performed. The setting value of this bit is enabled from the next frame.</p> <p>If the host controller module detects isochronous ED (F = 1) during the periodic list processing, it checks the bit and determines whether to perform isochronous ED processing.</p> <p>1b: The processing of the isochronous ED is continued. 0b: The periodic list processing is stopped, and the bulk/control list processing is started.</p> <p>0b: The processing of the isochronous ED is disabled. 1b: The processing of the isochronous ED is enabled.</p>										
2	PLE	0	R/W	<p>Periodic List Enable</p> <p>This bit indicates whether the periodic list processing is performed for the next frame. The setting value of this bit is enabled from the next frame.</p> <p>The host controller module checks this bit before starting the periodic list processing.</p> <p>0b: The processing of the periodic list is disabled. 1b: The processing of the periodic list is enabled.</p>										
1, 0	CBSR	All 0	R/W	<p>Control Bulk Service Ratio</p> <p>This field defines the service ratio of the control transfer and bulk transfer. When the periodic list is processed, the service ratio defined in this field is used for transfer.</p> <table border="1"> <thead> <tr> <th>CBSR</th> <th>No. of Control EDs Over Bulk EDs Served</th> </tr> </thead> <tbody> <tr> <td>00b</td> <td>1 : 1</td> </tr> <tr> <td>01b</td> <td>2 : 1</td> </tr> <tr> <td>10b</td> <td>3 : 1</td> </tr> <tr> <td>11b</td> <td>4 : 1</td> </tr> </tbody> </table>	CBSR	No. of Control EDs Over Bulk EDs Served	00b	1 : 1	01b	2 : 1	10b	3 : 1	11b	4 : 1
CBSR	No. of Control EDs Over Bulk EDs Served													
00b	1 : 1													
01b	2 : 1													
10b	3 : 1													
11b	4 : 1													

(3) HcCommandStatus Register

Abbreviated name of register: HcCommandStatus

Bit	31	30	29	28	27	26	25	24	23	22	21	20	19	18	17	16
	—	—	—	—	—	—	—	—	—	—	—	—	—	—	SOC	
Initial Value	0	0	0	0	0	0	0	0	0	0	0	0	0	0	0	0
R/W	R	R	R	R	R	R	R	R	R	R	R	R	R	R	R	R
Bit	15	14	13	12	11	10	9	8	7	6	5	4	3	2	1	0
	—	—	—	—	—	—	—	—	—	—	—	—	—	BLF	CLF	HCR
Initial Value	0	0	0	0	0	0	0	0	0	0	0	0	0	0	0	0
R/W	R	R	R	R	R	R	R	R	R	R	R	R	R	R/W	R/W	W

Bit	Bit Name	Initial Value	R/W	Description
31 to 18	—	All 0	R	Reserved The write value should always be 0.
17, 16	SOC	All 0	R	Scheduling Overrun Count This field counts the number of scheduling overrun. This field is initialized to 00b, and is counted up every time scheduling overrun is detected. After the field is incremented to 11b, it returns to 00b. Even if the SO (Scheduling Overrun) bit in the HcInterrupt Status register is set, this field is counted up when scheduling overrun is detected.
15 to 3	—	All 0	R	Reserved The write value should always be 0.
2	BLF	0	R/W	BulkList Filled This bit indicates whether TD exists in the bulk list. To add TD to ED in the bulk list, set this bit to 1b. The host controller checks this bit when it starts processing of the head ED in the bulk list. If this bit is set to 0b, the host controller does not start the list processing. If this bit is set to 1b, the host controller starts processing of the bulk list, and sets this bit to 0b. When the host controller finds TD in the bulk list, it sets this bit to 1b again, and continues processing of the bulk list. When the host controller finishes the list processing, this bit is set to 0b. However, if TD is not found in the bulk list, or if this bit is not set to 1b, this bit remains to be 0b, and the list processing stops. To rebuild the list and start the list processing, before you set the BLE bit of the HcControl register and start the list processing, you need to set this bit. 0b: TD does not exist in the bulk list. 1b: TD exists in the bulk list.

Bit	Bit Name	Initial Value	R/W	Description
1	CLF	0	R/W	<p>ControlList Filled</p> <p>This bit indicates whether TD exists in the control list. To add TD to ED in the control list, set this bit to 1b. The host controller checks this bit when it starts processing of the head ED in the control list. If this bit is set to 0b, the host controller does not start the processing of the control list. If this bit is set to 1b, the host controller starts processing of the control list, and set this bit to 0b. When the host controller finds TD in the control list, it sets this bit to 1b again, and continues the list processing. When the host controller finishes the list processing, this bit is set to 0b. However, if TD is not found in the control list, or if this bit is not set to 1b, this bit remains to be 0b, and the list processing stops. To rebuild the list and start the list processing, before you set the CLE bit of the HcControl register and start the list processing, you need to set this bit.</p> <p>0b: TD does not exist in the control list. 1b: TD exists in the control list.</p>
0	HCR	0	W	<p>Host Controller Reset</p> <p>This bit is used to start OHCI software reset for the host controller. When this bit is set to 1b, the operating status of the host controller is changed to USB Suspend regardless of the functional state of the host controller. Also, the most OHCI Operational registers and OHCI control circuits are initialized. When the software reset finishes, the host controller clears this bit to 0b.</p>

(4) HcInterruptStatus Register

Abbreviated name of register: HcInterruptStatus

Bit	31	30	29	28	27	26	25	24	23	22	21	20	19	18	17	16
	—	—	—	—	—	—	—	—	—	—	—	—	—	—	—	—
Initial Value	0	0	0	0	0	0	0	0	0	0	0	0	0	0	0	0
R/W	R	R	R	R	R	R	R	R	R	R	R	R	R	R	R	R
Bit	15	14	13	12	11	10	9	8	7	6	5	4	3	2	1	0
	—	—	—	—	—	—	—	—	—	RHSC	FNO	UE	RD	SF	WDH	SO
Initial Value	0	0	0	0	0	0	0	0	0	0	0	0	0	0	0	0
R/W	R	R	R	R	R	R	R	R	R	R/W	R/W	R/W	R/W	R/W	R/W	R/W

Bit	Bit Name	Initial Value	R/W	Description
31 to 7	—	All 0	R	Reserved The write value should always be 0.
6	RHSC	0	R/W	Root Hub Status Change Interrupt bit that indicates that the state of the HcRhStatus register or HcRhPortStatus1 register has changed. When the Root Hub status is changed, the host controller sets this bit to 1b. Writing 1b to this bit clears the interrupt. 0b: The status of root hub has not changed. 1b: The status of root hub has changed.
5	FNO	0	R/W	Frame Number Overflow Interrupt bit that indicates that the MSB in the FrameNumber (FN) field of the HcFmNumber register has changed. When the MSB in the Frame Number field is changed from 0 to 1, or from 1 to 0, this bit is set after HccaFrameNumber is updated. Writing this bit to 1b clears the interrupt. 0b: The overflow of frame number has not occurred. 1b: The overflow of frame number has occurred.
4	UE	0	R/W	Unrecoverable Error Interrupt bit that indicates that a system error that is not related to the USB (for example, an error on the system bus) has been detected. Writing this bit to 1b clears the interrupt. 0b: The unrecoverable error has not occurred. 1b: The unrecoverable error has occurred.
3	RD	0	R/W	Resume Detected Interrupt bit that indicates that Resume has been detected. When the host controller detects the Resume signal (RemoteWakeup) from an USB device, it sets this bit to 1b. This bit is not set when the Resume signal is sent by setting the HCFS field to USB Resume. Writing this bit to 1b clears the interrupt. 0b: The host controller has not detected resume signaling (RemoteWakeup). 1b: The host controller has detected resume signaling (RemoteWakeup).

Bit	Bit Name	Initial Value	R/W	Description
2	SF	0	R/W	<p>Start of Frame</p> <p>Interrupt bit that indicates that Hcca Frame Number was updated when each frame started.</p> <p>The host controller sends an SOF packet and updates HccaFrameNumber at the same time, and sets this bit to 1b.</p> <p>Writing this bit to 1b clears the interrupt.</p> <p>0b: The host controller has not started new frame. 1b: The host controller has started new frame.</p>
1	WDH	0	R/W	<p>Writeback DoneHead</p> <p>Interrupt bit that indicates that the host controller has written the contents of HcDoneHead to HccDoneHead.</p> <p>The host controller sets this bit to 1b immediately after it updates HccaDoneHead.</p> <p>Note that HccaDoneHead is not updated until this bit is cleared.</p> <p>Writing this bit to 1b clears the interrupt.</p> <p>This bit must be cleared only after the contents of HccaDoneHead are saved.</p> <p>0b: The write back to HccaDoneHead has not occurred. 1b: The write back to HccaDoneHead has occurred.</p>
0	SO	0	R/W	<p>Scheduling Overrun</p> <p>Interrupt bit that indicates that overrun of the USB schedule occurred.</p> <p>When USB scheduling overrun occurs, the host controller updates HccaFrameNumber, and sets this bit to 1b. When this bit is set, the SchedulingOverrunCount field of the HcCommandStatus register is also incremented.</p> <p>Writing this bit to 1b clears the interrupt.</p> <p>0b: The scheduling overrun has not occurred. 1b: The scheduling overrun has occurred.</p>

(5) HcInterruptEnable Register

Abbreviated name of register: HcInterruptEnable

Bit	31	30	29	28	27	26	25	24	23	22	21	20	19	18	17	16
	MIE	OCE	—	—	—	—	—	—	—	—	—	—	—	—	—	—
Initial Value	0	0	0	0	0	0	0	0	0	0	0	0	0	0	0	0
R/W	R/W	R/W	R	R	R	R	R	R	R	R	R	R	R	R	R	R
Bit	15	14	13	12	11	10	9	8	7	6	5	4	3	2	1	0
	—	—	—	—	—	—	—	—	—	RHSCE	FNOE	UEE	RDE	SFE	WDHE	SOE
Initial Value	0	0	0	0	0	0	0	0	0	0	0	0	0	0	0	0
R/W	R	R	R	R	R	R	R	R	R	R/W	R/W	R/W	R/W	R/W	R/W	R/W

Bit	Bit Name	Initial Value	R/W	Description
31	MIE	0	R/W	<p>Master Interrupt Enable</p> <p>This bit sets whether each Interrupt Enable setting (which is set in HcInterruptEnable [30:0]) is enabled.</p> <p>If this bit is set to 0b, all OHCI interrupts are masked.</p> <p>To clear this bit, set the MID bit (bit 31) of the HcInterruptDisable register to 1b.</p> <p>0b: All interrupts are disabled.</p> <p>1b: Interrupts that are set to 1b are enabled.</p>
30	OCE	0	R/W	<p>OC (Ownership Change) Interrupt Enable bit.</p> <p>If this bit is set to 1b, the interrupt source becomes OC (OwnershipChange).</p> <p>To clear this bit, set the OCD bit (bit 30) of the HcInterruptDisable register to 1b.</p> <p>0b: OC (OwnershipChange) interrupt is disabled.</p> <p>1b: OC (OwnershipChange) interrupt is enabled.</p>
29 to 7	—	All 0	R	<p>Reserved</p> <p>The write value should always be 0.</p>
6	RHSCE	0	R/W	<p>RHSC (RootHub Status Change) Interrupt Enable bit.</p> <p>If this bit is set to 1b, the interrupt source becomes RHSC (RootHub Status Change).</p> <p>To clear this bit, set the RHSCD bit (bit 6) of the HcInterruptDisable register to 1b.</p> <p>0b: RHSC (RootHub Status Change) interrupt is disabled.</p> <p>1b: RHSC (RootHub Status Change) interrupt is enabled.</p>
5	FNOE	0	R/W	<p>FNO (Frame Number Overflow) Interrupt Enable bit.</p> <p>If this bit is set to 1b, the interrupt source becomes FNO (Frame Number Overflow).</p> <p>To clear this bit, set the FNOD bit (bit 5) of the HcInterruptDisable register to 1b.</p> <p>0b: FNO (Frame Number Overflow) interrupt is disabled.</p> <p>1b: FNO (Frame Number Overflow) interrupt is enabled.</p>
4	UEE	0	R/W	<p>UE (Unrecoverable Error) Interrupt Enable bit.</p> <p>If this bit is set to 1b, the interrupt source becomes UE (Unrecoverable Error).</p> <p>To clear this bit, set the UED bit (bit 4) of the HcInterruptDisable register to 1b.</p> <p>0b: UE (Unrecoverable Error) interrupt is disabled.</p> <p>1b: UE (Unrecoverable Error) interrupt is enabled.</p>
3	RDE	0	R/W	<p>RD (Resume Detect) Interrupt Enable bit.</p> <p>If this bit is set to 1b, the interrupt source becomes RD (Resume Detect).</p> <p>To clear this bit, set the RDD bit (bit 3) of the HcInterruptDisable register to 1b.</p> <p>0b: RD (Resume Detect) interrupt is disabled.</p> <p>1b: RD (Resume Detect) interrupt is enabled.</p>

Bit	Bit Name	Initial Value	R/W	Description
2	SFE	0	R/W	<p>SF (Start of Frame) Interrupt Enable bit.</p> <p>If this bit is set to 1b, the interrupt source becomes SF (Start of Frame).</p> <p>To clear this bit, set the SFD bit (bit 2) of the HcInterruptDisable register to 1b.</p> <p>0b: SF (Start of Frame) interrupt is disabled.</p> <p>1b: SF (Start of Frame) interrupt is enabled.</p>
1	WDHE	0	R/W	<p>WDH (Writeback DoneHead) Interrupt Enable bit.</p> <p>If this bit is set to 1b, the interrupt source becomes WDH (Writeback DoneHead).</p> <p>To clear this bit, set the WDHDD bit (bit 1) of the HcInterruptDisable register to 1b.</p> <p>0b: WDH (Writeback DoneHead) interrupt is disabled.</p> <p>1b: WDH (Writeback DoneHead) interrupt is enabled.</p>
0	SOE	0	R/W	<p>SO (Scheduling Overrun) Interrupt Enable bit.</p> <p>If this bit is set to 1b, the interrupt source becomes SO (Scheduling Overrun).</p> <p>To clear this bit, set the SOD bit (bit 0) of the HcInterruptDisable register to 1b.</p> <p>0b: SO (Scheduling Overrun) interrupt is disabled.</p> <p>1b: SO (Scheduling Overrun) interrupt is enabled.</p>

(6) HcInterruptDisable Register

Abbreviated name of register: HcInterruptDisable

Bit	31	30	29	28	27	26	25	24	23	22	21	20	19	18	17	16
	MID	OCD	—	—	—	—	—	—	—	—	—	—	—	—	—	—
Initial Value	0	0	0	0	0	0	0	0	0	0	0	0	0	0	0	0
R/W	R/W(1)	R/W(1)	R	R	R	R	R	R	R	R	R	R	R	R	R	R
Bit	15	14	13	12	11	10	9	8	7	6	5	4	3	2	1	0
	—	—	—	—	—	—	—	—	—	RHSCD	FNOD	UED	RDD	SFD	WDHD	SOD
Initial Value	0	0	0	0	0	0	0	0	0	0	0	0	0	0	0	0
R/W	R	R	R	R	R	R	R	R	R	R/W(1)	R/W(1)	R/W(1)	R/W(1)	R/W(1)	R/W(1)	R/W(1)

Bit	Bit Name	Initial Value	R/W	Description
31	MID	0	R/W (1)	Master Interrupt Disable This bit sets whether the Enable setting (for each interrupt) that is set by HcInterruptEnable[30:0] is disabled. If this bit is set to 1b, the MIE bit (bit 31) of the HcInterruptEnable register is cleared to 0b, and all OHCI interrupts are masked. Writing 0b to this bit is ignored.
30	OCD	0	R/W (1)	OC (Ownership Change) Interrupt Disable bit. If this bit is set to 1b, the OCE bit (bit 30) of the HcInterruptEnable register is cleared to 0b, and OC (Ownership Change) is excluded from the interrupt source. Writing 0b to this bit is ignored.
29 to 7	—	All 0	R	Reserved The write value should always be 0.
6	RHSCD	0	R/W (1)	RHSC (RootHub Status Change) Interrupt Disable bit. If this bit is set to 1b, the RHSCE bit (bit 6) of the HcInterruptEnable register is cleared to 0b, and RHSC (RootHub Status Change) is excluded from the interrupt source. Writing 0b to this bit is ignored.
5	FNOD	0	R/W (1)	FNO (Frame Number Overflow) Interrupt Disable bit. If this bit is set to 1b, the FNOE bit (bit 5) of the HcInterruptEnable register is cleared to 0b, and FNO (Frame Number Overflow) is excluded from the interrupt source. Writing 0b to this bit is ignored.
4	UED	0	R/W (1)	UE (Unrecoverable Error) Interrupt Disable bit. If this bit is set to 1b, the UEE bit (bit 4) of the HcInterruptEnable register is cleared to 0b, and UE (Unrecoverable Error) is excluded from the interrupt source. Writing 0b to this bit is ignored.
3	RDD	0	R/W (1)	RD (Resume Detected) Interrupt Disable bit. If this bit is set to 1b, the RDE bit (bit 3) of the HcInterruptEnable register is cleared to 0b, and RD (Resume Detected) is excluded from the interrupt source. Writing 0b to this bit is ignored.
2	SFD	0	R/W (1)	SF (Start of Frame) Interrupt Disable bit. If this bit is set to 1b, the SFE bit (bit 2) of the HcInterruptEnable register is cleared to 0b, and SF (Start of Frame) is excluded from the interrupt source. Writing 0b to this bit is ignored.
1	WDHD	0	R/W (1)	WDH (Writeback DoneHead) Interrupt Disable bit. If this bit is set to 1b, the WDHE bit (bit 1) of the HcInterruptEnable register is cleared to 0b, and WDH (Writeback DoneHead) is excluded from the interrupt source. Writing 0b to this bit is ignored.

Bit	Bit Name	Initial Value	R/W	Description
0	SOD	0	R/W (1)	SO (Scheduling Overrun) Interrupt Disable bit. If this bit is set to 1b, the SOE bit (bit 1) of the HcInterruptEnable register is cleared to 0b, and SO (Scheduling Overrun) is excluded from the interrupt source. Writing 0b to this bit is ignored.

(7) HcHCCA Register

Abbreviated name of register: HcHCCA

Bit	31	30	29	28	27	26	25	24	23	22	21	20	19	18	17	16
	HcHCCA[31:24]								HcHCCA[23:16]							
Initial Value	0	0	0	0	0	0	0	0	0	0	0	0	0	0	0	0
R/W	R/W	R/W	R/W	R/W	R/W	R/W	R/W	R/W	R/W	R/W	R/W	R/W	R/W	R/W	R/W	R/W
Bit	15	14	13	12	11	10	9	8	7	6	5	4	3	2	1	0
	HcHCCA[15:8]								—	—	—	—	—	—	—	
Initial Value	0	0	0	0	0	0	0	0	0	0	0	0	0	0	0	0
R/W	R/W	R/W	R/W	R/W	R/W	R/W	R/W	R/W	R	R	R	R	R	R	R	R

Bit	Bit Name	Initial Value	R/W	Description
31 to 8	HcHCCA	All 0	R/W	This field sets the base address (of the RAM) that is assigned as the Host Controller Communication Area. This field must be set at initialization. The host controller requests (as HCCA) 256-byte area from the base address specified in this field.
7 to 0	—	All 0	R	Reserved The write value should always be 0.

(8) HcPeriodicCurrentED Register

Abbreviated name of register: HcPeriodCurrentED

Bit	31	30	29	28	27	26	25	24	23	22	21	20	19	18	17	16
	PECD[31:24]								PECD[23:16]							
Initial Value	0	0	0	0	0	0	0	0	0	0	0	0	0	0	0	0
R/W	R	R	R	R	R	R	R	R	R	R	R	R	R	R	R	R
Bit	15	14	13	12	11	10	9	8	7	6	5	4	3	2	1	0
	PECD[15:8]								PECD[7:4]				—	—	—	—
Initial Value	0	0	0	0	0	0	0	0	0	0	0	0	0	0	0	0
R/W	R	R	R	R	R	R	R	R	R	R	R	R	R	R	R	R

Bit	Bit Name	Initial Value	R/W	Description
31 to 4	PECD	All 0	R	Period Current ED This pointer indicates the physical address of ED in the periodic list that is currently processed. The host controller updates this pointer when the list processing of the periodic ED finishes.
3 to 0	—	All 0	R	Reserved The write value should always be 0.

(9) HcControlHeadED Register

Abbreviated name of register: HcControlHeadED

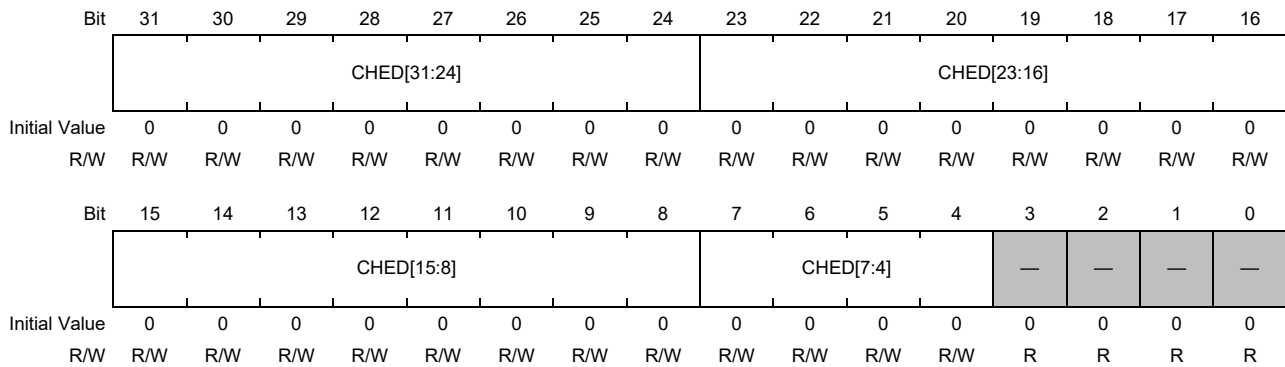

Bit	Bit Name	Initial Value	R/W	Description
31 to 4	CHED	All 0	R/W	Control Head ED This field specifies the physical address of the head ED of the control list. These bits must be set for control transfer before the CLE bit of the HcControl register is set. The host controller starts processing of the control list from the HcBulkHeadED pointer.
3 to 0	—	All 0	R	Reserved The write value should always be 0.

(10) HcControlCurrentED Register

Abbreviated name of register: HcControlCurrentED

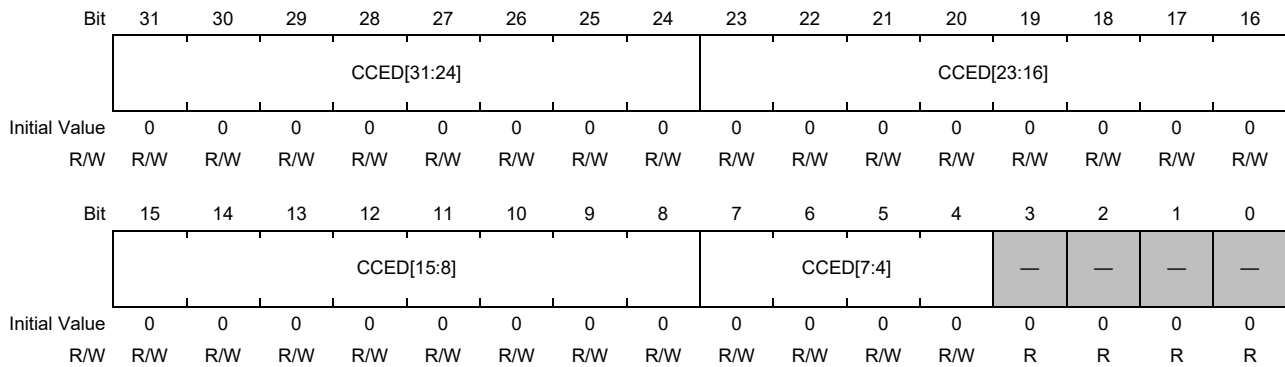

Bit	Bit Name	Initial Value	R/W	Description
31 to 4	CCED	All 0	R/W	<p>Control Current ED</p> <p>This pointer indicates the physical address of the ED that is currently processed in the control list. After the current ED processing finishes, this pointer proceeds to the next ED.</p> <p>The host controller continues the list processing until the end of the frame. When the end of the control list is reached, the host controller checks the ControlListFilled bit of the HcCommandStatus register. If the corresponding bit is set to 1b, the contents of the HcControlHeadED field are copied to the HcControlCurrentED field, and the ControlListFilled bit is cleared. If the corresponding bit is set to 0b, nothing is performed.</p> <p>Update of this register is allowed only when the ControlListEnable bit of the HcControl register is cleared. If the ControlListEnable bit is set to 1b, the value of this register is only read. This register is initially set to H'0 to indicate the end of the control list.</p>
3 to 0	—	All 0	R	<p>Reserved</p> <p>The write value should always be 0.</p>

(11) HcBulkHeadED Register

Abbreviated name of register: HcBulkHeadED

Bit	31	30	29	28	27	26	25	24	23	22	21	20	19	18	17	16
	BHED[31:24]								BHED[23:16]							
Initial Value	0	0	0	0	0	0	0	0	0	0	0	0	0	0	0	0
R/W	R/W	R/W	R/W	R/W	R/W	R/W	R/W	R/W	R/W	R/W	R/W	R/W	R/W	R/W	R/W	R/W
Bit	15	14	13	12	11	10	9	8	7	6	5	4	3	2	1	0
	BHED[15:8]								BHED[7:4]				—	—	—	—
Initial Value	0	0	0	0	0	0	0	0	0	0	0	0	0	0	0	0
R/W	R/W	R/W	R/W	R/W	R/W	R/W	R/W	R/W	R/W	R/W	R/W	R/W	R	R	R	R

Bit	Bit Name	Initial Value	R/W	Description
31 to 4	BHED	All 0	R/W	Bulk Head ED This field specifies the physical address of the head ED of the bulk list. This field must be set for bulk transfer before the BLE bit of the HcControl register is set. The host controller starts the processing of the control list from the HcBulkHeadED pointer.
3 to 0	—	All 0	R	Reserved The write value should always be 0.

(12) HcBulkCurrentED Register

Abbreviated name of register: HcBulkCurrentED

Bit	31	30	29	28	27	26	25	24	23	22	21	20	19	18	17	16
	BCED[31:24]								BCED[23:16]							
Initial Value	0	0	0	0	0	0	0	0	0	0	0	0	0	0	0	0
R/W	R/W	R/W	R/W	R/W	R/W	R/W	R/W	R/W	R/W	R/W	R/W	R/W	R/W	R/W	R/W	R/W
Bit	15	14	13	12	11	10	9	8	7	6	5	4	3	2	1	0
	BCED[15:8]								BCED[7:4]				—	—	—	—
Initial Value	0	0	0	0	0	0	0	0	0	0	0	0	0	0	0	0
R/W	R/W	R/W	R/W	R/W	R/W	R/W	R/W	R/W	R/W	R/W	R/W	R/W	R	R	R	R

Bit	Bit Name	Initial Value	R/W	Description
31 to 4	BCED	All 0	R/W	<p>Bulk Current ED</p> <p>This pointer indicates the physical address of the ED that is currently processed in the bulk list. After the current ED processing finishes, this pointer proceeds to the next ED. The host controller continues the list processing until the end of the frame. When the end of the bulk list is reached, the host controller checks the ControllListFilled bit of the HcCommandStatus register. If the corresponding bit is set to 1b, the contents of the HcBulkHeadED field are copied to the HcBulkCurrentED field, and the ControllListFilled bit is cleared. If the corresponding bit is set to 0b, nothing is performed.</p> <p>Update of this register is allowed only when the ControllListEnable bit of the HcControl register is cleared. If the ControllListEnable bit is set to 1b, the value of this register is only read. This register is initially set to H'0 to indicate the end of the bulk list.</p>
3 to 0	—	All 0	R	<p>Reserved</p> <p>The write value should always be 0.</p>

(13) HcDoneHead Register

Abbreviated name of register: HcDoneHead

Bit	31	30	29	28	27	26	25	24	23	22	21	20	19	18	17	16
	DH[31:24]								DH[23:16]							
Initial Value	0	0	0	0	0	0	0	0	0	0	0	0	0	0	0	0
R/W	R	R	R	R	R	R	R	R	R	R	R	R	R	R	R	R
Bit	15	14	13	12	11	10	9	8	7	6	5	4	3	2	1	0
	DH[15:8]								DH[7:4]				—	—	—	—
Initial Value	0	0	0	0	0	0	0	0	0	0	0	0	0	0	0	0
R/W	R	R	R	R	R	R	R	R	R	R	R	R	R	R	R	R

Bit	Bit Name	Initial Value	R/W	Description
31 to 4	DH	All 0	R	<p>Done Head</p> <p>This field indicates the physical address of the HcDoneHead of the host controller. The physical address of the TD that lately finished and is added to the Done queue. After the TD processing finishes, the host controller writes the contents of the HcDoneHead to the NextTD field of the TD. At the same time, the host controller overwrites the contents of HcDoneHead with the TD address. After the host controller writes the contents of this register into HCCA, it sets 0b to this register. Then, the WritebackDoneHead bit of the HcInterruptStatus register is set to 1b.</p>
3 to 0	—	All 0	R	<p>Reserved</p> <p>The write value should always be 0.</p>

(14) HcFmInterval Register

Register abbreviation: HcFmInterval

Bit	31	30	29	28	27	26	25	24	23	22	21	20	19	18	17	16
	FIT		FSMPS[30:24]							FSMPS[23:16]						
Initial Value	0	0	0	0	0	0	0	0	0	0	0	0	0	0	0	0
R/W	R/W	R/W	R/W	R/W	R/W	R/W	R/W	R/W	R/W	R/W	R/W	R/W	R/W	R/W	R/W	R/W
Bit	15	14	13	12	11	10	9	8	7	6	5	4	3	2	1	0
	—		FI[13:8]							FI[7:0]						
Initial Value	0	0	1	0	1	1	1	0	1	1	0	1	1	1	1	1
R/W	R	R	R/W	R/W	R/W	R/W	R/W	R/W	R/W	R/W	R/W	R/W	R/W	R/W	R/W	R/W

Bit	Bit Name	Initial Value	R/W	Description
31	FIT	0	R/W	<p>Frame Interval Toggle</p> <p>This bit is used to synchronize the frame setting value with the hardware (host controller). When the FI field is updated, the toggle value is written to this bit. When the FI field value is applied to the FR field of the HcFmRemaining register, the value of this bit is also applied to the FRT bit of the HcFmRemaining register.</p> <p>By checking the toggle value in the FRT bit of the cFmRemaining register, the software can check whether the value in the FI field has been applied to the FR field of the HcFmRemaining register.</p>
30 to 16	FSMPS	All 0	R/W	<p>FS Largest Data Packet</p> <p>This field sets the maximum amount of data (bits) that the host controller can send and receive without the fear of schedule overrun.</p> <p>The host controller compares the current frame position and the setting value in this field to determine the length (of the frame) that is ready to be transferred.</p> <p>This value differs depending on the capacity of the system bus and other reasons, estimate the value and set it to this field.</p> <p><i>Note:</i> The maximum setting value for this field is H'2778. Do not set any value that is larger than H'2778.</p>
15, 14	—	All 0	R	<p>Reserved</p> <p>The write value should always be 0.</p>
13 to 0	FI	H'2EDF	R/W	<p>Frame Interval</p> <p>This field is used to set the length of the frame (bit time) used for Full Speed. Set the value of this field to "H'2EDF" so that 1 frame (= 1 ms) of USB standard is satisfied.</p>

(15) HcFmRemaining Register

Register abbreviation: HcFmRemaining

Bit	31	30	29	28	27	26	25	24	23	22	21	20	19	18	17	16	
	FRT	—	—	—	—	—	—	—	—	—	—	—	—	—	—	—	
Initial Value	0	0	0	0	0	0	0	0	0	0	0	0	0	0	0	0	
R/W	R	R	R	R	R	R	R	R	R	R	R	R	R	R	R	R	
Bit	15	14	13	12	11	10	9	8	7	6	5	4	3	2	1	0	
	—	—	FR[13:8]						FR[7:0]								
Initial Value	0	0	1	0	1	1	1	0	1	1	0	1	1	1	1	1	
R/W	R	R	R	R	R	R	R	R	R	R	R	R	R	R	R	R	

Bit	Bit Name	Initial Value	R/W	Description
31	FRT	0	R	Frame Remaining Toggle This bit is used to synchronize the frame setting value with the hardware (host controller). When the FR (Frame Remaining) field is set to H'0000, the host controller copies the FI (Frame Interval) field value to the FR field, and copies the FIT (Frame Interval Toggle) bit value to this bit. This bit can be used to check that the FI field of the HcFmInterval register has been correctly copied to the FR field.
30 to 14	—	All 0	R	Reserved The write value should always be 0.
13 to 0	FR	H'2EDF	R	Frame Remaining This field indicates the current frame value for 14-bit down counter. The value in this field counts down as time passes. When the value becomes H'0000, the value of FI (Frame Interval) of the HcFmInterval register is loaded. When the state of the host controller is changed to the USB Operational state, the host controller reloads the value in the FI (Frame Interval) field of the HcFmInterval register, and the new value is used from the next SOF.

(16) HcFmNumber Register

Register abbreviation: HcFmNumber

Bit	31	30	29	28	27	26	25	24	23	22	21	20	19	18	17	16
	—	—	—	—	—	—	—	—	—	—	—	—	—	—	—	—
Initial Value	0	0	0	0	0	0	0	0	0	0	0	0	0	0	0	0
R/W	R	R	R	R	R	R	R	R	R	R	R	R	R	R	R	R
Bit	15	14	13	12	11	10	9	8	7	6	5	4	3	2	1	0
	FN[15:8]								FN[7:0]							
Initial Value	0	0	0	0	0	0	0	0	0	0	0	0	0	0	0	0
R/W	R	R	R	R	R	R	R	R	R	R	R	R	R	R	R	R

Bit	Bit Name	Initial Value	R/W	Description
31 to 16	—	All 0	R	Reserved The write value should always be 0.
15 to 0	FN	All 0	R	<p>Frame Number</p> <p>This field indicates the number of passed frames.</p> <p>When the HcFmRemaining register is reloaded, this field is incremented. If this field is reached to H'FFFF, the value is rolled over to H'0000. When the state of the host controller is changed to the USB Operational state, this field is automatically incremented. After the host controller increments the frame number at the frame boundary and sends SOF, the contents of this field are written to HCCA. This is performed before the host controller reads the first ED of the frame.</p> <p>After writing to HCCA, the host controller sets the SF bit of the HcInterruptStatus register.</p>

(17) HcPeriodicStart Register

Register abbreviation: HcPeriodicStart

Bit	31	30	29	28	27	26	25	24	23	22	21	20	19	18	17	16
	—	—	—	—	—	—	—	—	—	—	—	—	—	—	—	—
Initial Value	0	0	0	0	0	0	0	0	0	0	0	0	0	0	0	0
R/W	R	R	R	R	R	R	R	R	R	R	R	R	R	R	R	R
Bit	15	14	13	12	11	10	9	8	7	6	5	4	3	2	1	0
	—	—	PS[13:8]						PS[7:0]							
Initial Value	0	0	0	0	0	0	0	0	0	0	0	0	0	0	0	0
R/W	R	R	R/W	R/W	R/W	R/W	R/W	R/W	R/W	R/W	R/W	R/W	R/W	R/W	R/W	R/W

Bit	Bit Name	Initial Value	R/W	Description
31 to 14	—	All 0	R	Reserved The write value should always be 0.
13 to 0	PS	All 0	R/W	<p>Periodic Start</p> <p>This field indicates the time the host controller starts the periodic list processing in the frame. Estimate an appropriate value, and set the value to this field at the initial setting of the host controller. OHCI standard recommends that you set this setting value to about 90% of the FI field value of the HcFmInterval register.</p> <p>The recommended value is H'2A2F.</p> <p>When the value in the FR field of the HcFmRemaining register reaches the value set to this field, the periodic list processing is given priority over the control/bulk list processing.</p> <p>Therefore, after the currently running control or bulk transfer finishes, the host controller starts the Interrupt list processing.</p>

(18) HcLSThreshold Register

Register abbreviation: HcLSThreshold

Bit	31	30	29	28	27	26	25	24	23	22	21	20	19	18	17	16
	—	—	—	—	—	—	—	—	—	—	—	—	—	—	—	—
Initial Value	0	0	0	0	0	0	0	0	0	0	0	0	0	0	0	0
R/W	R	R	R	R	R	R	R	R	R	R	R	R	R	R	R	R
Bit	15	14	13	12	11	10	9	8	7	6	5	4	3	2	1	0
	—	—	—	—	LST[11:8]				LST[7:0]							
Initial Value	0	0	0	0	0	1	1	0	0	0	1	0	1	0	0	0
R/W	R	R	R	R	R/W	R/W	R/W	R/W	R/W	R/W	R/W	R/W	R/W	R/W	R/W	R/W

Bit	Bit Name	Initial Value	R/W	Description
31 to 12	—	All 0	R	Reserved The write value should always be 0.
11 to 0	LST	H'628	R/W	LS Threshold This field indicates the threshold value of whether transfer is available for the remaining time of the LS transfer frame. If the value of the FR field of the FmRemaining register is larger than the value set to this field, the host controller can start LS transfer.

(19) HcRhDescriptorA Register

Register abbreviation: HcRhDescriptorA

Bit	31	30	29	28	27	26	25	24	23	22	21	20	19	18	17	16
	POTPGT								—	—	—	—	—	—	—	—
Initial Value	0	0	0	0	1	1	1	1	0	0	0	0	0	0	0	0
R/W	R/W	R/W	R/W	R/W	R/W	R/W	R/W	R/W	R	R	R	R	R	R	R	R
Bit	15	14	13	12	11	10	9	8	7	6	5	4	3	2	1	0
	—	—	—	NOCP	OCPM	DT	NPS	PSM	NDP							
Initial Value	0	0	0	0	1	0	0	1	0	0	0	0	0	0	0	1
R/W	R	R	R	R/W	R/W	R	R/W	R/W	R	R	R	R	R	R	R	R

Bit	Bit Name	Initial Value	R/W	Description
31 to 24	POTPGT	H'0F	R/W	PowerOn To PowerGood Time This field indicates the time for waiting until software can access the root hub port after the power is supplied to the port. The unit of time is 2 ms. Therefore, the wait time is POTPGT × 2 ms.
23 to 13	—	All 0	R	Reserved The write value should always be 0.
12	NOCP	0	R/W	No OverCurrent Protection This bit sets whether the overcurrent function of the root hub is supported. If this bit is set to 0b, the overcurrent state is reported depending on the setting of the OCPM bit. 0b: The overcurrent state is supported. 1b: The overcurrent state is not supported. If you do not require the overcurrent function, set this bit to 1b once the module is released from module standby. For details, see Section 32A.9.1, Host/Peripheral Common Setting Sequence .
11	OCPM	1	R/W	OverCurrent Protection Mode This bit sets how to report the overcurrent state of the root hub. If this bit is reset, this bit must indicate the same mode as the PSM (Power Switching Mode) bit. This bit is valid only when the NOCP (NoOverCurrent Protection) bit is cleared (0b). 0b: The overcurrent state is collectively reported for all ports. 1b: The overcurrent state is reported for each port.
10	DT	0	R	Device Type This bit indicates that the root hub is not a composite device. This bit is always 0b because the root hub is not allowed to be a composite device.
9	NPS	0	R/W	No Power Switching This bit sets how to control the port power. If this bit is set to 0b, the PSM bit is used to set whether the power control is collectively performed for all ports or is performed for each port. 0b: The port power can be switched between on and off. 1b: The power is always on while the host controller is running.
8	PSM	1	R/W	Power Switching Mode This bit sets how to control the power switch for each port of the root hub. This bit is valid only when the NPS bit is 0b. 0b: The power of all ports is collectively controlled. 1b: The power of ports is controlled for each port. If the PPCM (PortPower Control Mask) bit of the HcRhDescriptorB register is set, each port responds only to the Set/ClearPortPower command. If the PPCM bit is cleared, each port is controlled by the Set/ClearGlobalPower command.

Bit	Bit Name	Initial Value	R/W	Description
7 to 0	NDP	H'01	R	Number Down stream Ports This field indicates the number of downstream ports supported by the root hub.

(20) HcRhDescriptorB Register

Register abbreviation: HcRhDescriptorB

Bit	31	30	29	28	27	26	25	24	23	22	21	20	19	18	17	16
	—	—	—	—	—	—	—	—	—	—	—	—	—	—	PPCM	—
Initial Value	0	0	0	0	0	0	0	0	0	0	0	0	0	0	1	0
R/W	R	R	R	R	R	R	R	R	R	R	R	R	R	R	R/W	R
Bit	15	14	13	12	11	10	9	8	7	6	5	4	3	2	1	0
	—	—	—	—	—	—	—	—	—	—	—	—	—	—	DR	—
Initial Value	0	0	0	0	0	0	0	0	0	0	0	0	0	0	0	0
R/W	R	R	R	R	R	R	R	R	R	R	R	R	R	R	R/W	R

Bit	Bit Name	Initial Value	R/W	Description
31 to 18	—	All 0	R	Reserved The write value should always be 0.
17	PPCM	0	R/W	PortPower Control Mask This bit sets the port power control command when the PSM (Power Switching Mode) bit of the HcRhDescriptorA register is set. If this bit is 0b, the Global Power Control command (Set/ClearGlobalPower) is used for control. If this bit is 1b, the Port Power Control command (Set/ClearPortPower) is used for control. If the PSM bit is 0b, this bit is ignored.
16 to 2	—	All 0	R	Reserved The write value should always be 0.
1	DR	0	R/W	Device Removable This bit indicates whether each port of the root hub is removable. If this bit is 0b, the connected device is removable. If this bit is 1b, the connected device is not removable.
0	—	0	R	Reserved The write value should always be 0.

(21) HcRhStatus Register

Register abbreviation: HcRhStatus

Bit	31	30	29	28	27	26	25	24	23	22	21	20	19	18	17	16
	CRWE	—	—	—	—	—	—	—	—	—	—	—	—	—	OCIC	LPSC
Initial Value	0	0	0	0	0	0	0	0	0	0	0	0	0	0	0	0
R/W	W	R	R	R	R	R	R	R	R	R	R	R	R	R	R/W(1)	R/W
Bit	15	14	13	12	11	10	9	8	7	6	5	4	3	2	1	0
	DRWE	—	—	—	—	—	—	—	—	—	—	—	—	—	OCI	LPS
Initial Value	0	0	0	0	0	0	0	0	0	0	0	0	0	0	0	0
R/W	R/W	R	R	R	R	R	R	R	R	R	R	R	R	R	R	R/W

Bit	Bit Name	Initial Value	R/W	Description																				
31	CRWE	0	W	<p>Clear RemoteWakeup Enable</p> <p>This bit is used to clear the DRWE bit.</p> <p>If this bit is set to 1b, DRWE (Device RemoteWakeup Enable) bit can be cleared.</p> <p>Writing 0b to this bit has no effect.</p>																				
30 to 18	—	All 0	R	<p>Reserved</p> <p>The write value should always be 0.</p>																				
17	OCIC	0	R/W (1)	<p>OverCurrent Indicator Change</p> <p>This bit is used to report the change in the OCI bit.</p> <p>If there is any change in the OCI bit, the host controller sets this bit to 1b.</p> <p>If 1b is written to this bit while this bit is set to 1b, this bit can be cleared.</p> <p>Writing 0b to this bit has no effect.</p> <p>0b: There is no change in the Overcurrent state.</p> <p>1b: There is a change in the Overcurrent state.</p>																				
16	LPSC	0	R/W	<p>The meaning of this bit differs depending on whether the operation is read or write.</p> <p>[Read] Local Power Status Change</p> <p>This bit is always read as 0b because the Local Power Status is not supported.</p> <p>[Write] Set Global Power</p> <p>If this bit is set to 1b, the power to the ports is turned on.</p> <p>The ports whose power is turned on are determined by the settings of the PSM (Power Switching Mode) bit and the PPCM (Port Power Control Mask) bit of the HcRhDescriptorA register.</p> <table border="1"> <thead> <tr> <th>written to this bit</th> <th>PSM</th> <th>PPCM[N]</th> <th>Description</th> </tr> </thead> <tbody> <tr> <td>0</td> <td>—</td> <td>—</td> <td>Setting ignored</td> </tr> <tr> <td>1</td> <td>0</td> <td>—</td> <td>1b is set to the PPS bit.</td> </tr> <tr> <td></td> <td>1</td> <td>0</td> <td>1b is set to the PPS bit.</td> </tr> <tr> <td></td> <td></td> <td>1</td> <td>Setting ignored</td> </tr> </tbody> </table> <p>Writing 0b to this bit has no effect.</p>	written to this bit	PSM	PPCM[N]	Description	0	—	—	Setting ignored	1	0	—	1b is set to the PPS bit.		1	0	1b is set to the PPS bit.			1	Setting ignored
written to this bit	PSM	PPCM[N]	Description																					
0	—	—	Setting ignored																					
1	0	—	1b is set to the PPS bit.																					
	1	0	1b is set to the PPS bit.																					
		1	Setting ignored																					
15	DRWE	0	R/W	<p>[Read] Device RemoteWakeup Enable</p> <p>This bit sets whether the RemoteWakeup event includes the CSC (Connect Status Change) bit.</p> <p>If this bit is set to 1b, the CSC bit of the HcRhPortStatus register becomes valid as the Resume event. If the CSC bit is changed to 1b, the state is changed from USB Suspend to USB Resume, and the Resume detection interrupt occurs.</p> <p>0b: Connect Status Change is not the source of RemoteWakeup.</p> <p>1b: Connect Status Change is the source of RemoteWakeup.</p> <p>[Write] Set RemoteWakeup Enable</p> <p>This bit is used to set the DRWE bit.</p> <p>Writing 0b to this bit has no effect.</p>																				

Bit	Bit Name	Initial Value	R/W	Description																			
14 to 2	—	All 0	R	Reserved The write value should always be 0.																			
1	OCI	0	R	Over Current Indicator This bit is used to report the overcurrent state in the global overcurrent detection mode (OCPM bit = 0b). This bit always indicates 0b when overcurrent for each port is reported (when OPCM bit = 1b). 0b: The port state is normal. 1b: The port is in the overcurrent state.																			
0	LPS	0	R/W	The meaning of this bit differs depending on whether the operation is read or write. [Read] Local Power Status This bit is always read as 0b because the Local Power Status is not supported. [Write] Clear Global Power If this bit is set to 1b, the power to the ports is turned off. The ports whose power is turned off are determined by the settings of the PSM (Power Switching Mode) bit and PPCM (Port Power Control Mask) bit of the HcRhDescriptorA register. <table border="1" data-bbox="614 833 1428 999"> <thead> <tr> <th>written to this bit</th> <th>PSM</th> <th>PPCM[N]</th> <th>Description</th> </tr> </thead> <tbody> <tr> <td>0</td> <td>—</td> <td>—</td> <td>Setting ignored.</td> </tr> <tr> <td rowspan="2">1</td> <td>0</td> <td>—</td> <td>The PPS bit is cleared to 0b.</td> </tr> <tr> <td>1</td> <td>0</td> <td>The PPS bit is cleared to 0b.</td> </tr> <tr> <td></td> <td></td> <td>1</td> <td>Setting ignored.</td> </tr> </tbody> </table> Writing 0b to this bit has no effect.	written to this bit	PSM	PPCM[N]	Description	0	—	—	Setting ignored.	1	0	—	The PPS bit is cleared to 0b.	1	0	The PPS bit is cleared to 0b.			1	Setting ignored.
written to this bit	PSM	PPCM[N]	Description																				
0	—	—	Setting ignored.																				
1	0	—	The PPS bit is cleared to 0b.																				
	1	0	The PPS bit is cleared to 0b.																				
		1	Setting ignored.																				

(22) HcRhPortStatus[1:NDP] Register

Register abbreviation: HcRhPortStatus1

Bit	31	30	29	28	27	26	25	24	23	22	21	20	19	18	17	16
	—	—	—	—	—	—	—	—	—	—	—	PRSC	OCIC	PSSC	PESC	CSC
Initial Value	0	0	0	0	0	0	0	0	0	0	0	0	0	0	0	0
R/W	R	R	R	R	R	R	R	R	R	R	R	R/W(1)	R/W(1)	R/W(1)	R/W(1)	R/W(1)
Bit	15	14	13	12	11	10	9	8	7	6	5	4	3	2	1	0
	—	—	—	—	—	—	LSDA	PPS	—	—	—	PRS	POCI	PSS	PES	CCS
Initial Value	0	0	0	0	0	0	0	0	0	0	0	0	0	0	0	0
R/W	R	R	R	R	R	R	R/W	R/W	R	R	R	R/W	R/W	R/W	R/W	R/W

Bit	Bit Name	Initial Value	R/W	Description
31 to 21	—	All 0	R	Reserved The write value should always be 0.
20	PRSC	0	R/W (1)	Port Reset Status Change This bit indicates that port reset (bus reset) has finished. The host controller sets this bit when 10 ms port reset (bus reset) finishes. 0b: Port reset has not finished, or the PRS (Port Reset Status) bit is not changed. 1b: Port reset has finished.
19	OCIC	0	R/W (1)	Port OverCurrent Indicator Change This bit is set when the overcurrent state of the port is detected. This bit is set when the host controller changed the POCI bit value. This bit is valid only under the setting that the overcurrent state is reported for each port (OCPM bit = 1b). If this bit is set to 1b, this bit is cleared. Writing 0b to this bit has no effect. 0b: The overcurrent state has not changed. 1b: The overcurrent state has changed (POCI bit changed).
18	PSSC	0	R/W (1)	Port Suspend Status Change This bit indicates that the Resume sequence finished. This sequence includes 20 ms of the Resume signal, LS EOP, and 3 ms of resynchronization delay. If this bit is set to 1b, this bit is cleared. Writing 0b to this bit has no effect. If the PRSC (Port Reset Status Change) bit is set, this bit is cleared. 0b: The Resume sequence has not finished. 1b: The Resume sequence has finished.
17	PESC	0	R/W (1)	Port Enable Status Change This bit indicates that the PES (Port Enable Status) bit was changed. If a hardware event clears the PES bit, this bit is set to 1b. If this bit is set to 1b, this bit is cleared. Writing 0b to this bit has no effect. 0b: The PES (Port Enable Status) bit has not changed. 1b: The PES (Port Enable Status) bit has changed.

Bit	Bit Name	Initial Value	R/W	Description
16	CSC	0	R/W (1)	<p>Connect Status Change</p> <p>This bit indicates that the CCS (Current Connect Status) bit was changed.</p> <p>If the Connect/Disconnect event occurs, this bit is set to 1b.</p> <p>If this bit is set to 1b, this bit is cleared.</p> <p>Writing 0b to this bit has no effect.</p> <p>If a request (Port Reset/Port Enable/Port Suspend) is received during the Disconnect status, this bit is set for reevaluation of device connection confirmation.</p> <p>0b: The CCS (Current Connect Status) bit has not changed.</p> <p>1b: The CCS (Current Connect Status) bit has changed.</p>
15 to 10	—	All 0	R	<p>Reserved</p> <p>The write value should always be 0.</p>
9	LSDA	0	R/W	<p>The meaning of this bit differs depending on whether the operation is read or write.</p> <p>[Read] Low Speed Device Attached</p> <p>This bit indicates the speed of the device connected to the port.</p> <p>This bit is valid only when the CCS (Current Connect Status) bit is set.</p> <p>0b: Full Speed device is connected.</p> <p>1b: Low Speed device is connected.</p> <p>[Write] Clear Port Power</p> <p>This bit is used to turn off the power of the port when the port is power controlled.</p> <p>Writing 1b to this bit turns off the port power.</p> <p>Writing 0b to this bit has no effect.</p>
8	PPS	0	R/W	<p>The meaning of this bit differs depending on whether the operation is read or write.</p> <p>[Read] Port Power Status</p> <p>This bit indicates the power status of the port.</p> <p>This bit is cleared when the overcurrent is detected.</p> <p>0b: Port power is off.</p> <p>1b: Port power is on.</p> <p>[Write] Set Port Power</p> <p>This bit is used to turn on the power of the port when the port is power controlled.</p> <p>Writing 1b to this bit turns on the port power.</p> <p>Writing 0b has no effect.</p>
7 to 5	—	All 0	R	<p>Reserved</p> <p>The write value should always be 0.</p>
4	PRS	0	R/W	<p>The meaning of this bit differs depending on whether the operation is read or write.</p> <p>[Read] Port Reset Status</p> <p>This bit indicates the port reset (bus reset) status.</p> <p>When 10 ms of port reset finishes, the PRSC (Port Reset Status Change) bit is set and this bit is cleared. When the CCS bit is cleared (when no device is connected), this bit cannot be set.</p> <p>0b: Not during port reset</p> <p>1b: During port reset</p> <p>[Write] Set Port Reset</p> <p>This bit is used to issue a port reset (bus reset) to the downstream port.</p> <p>Writing 1b to this bit starts 10 ms of port reset.</p> <p>Writing 0b to this bit has no effect.</p> <p>If CCS is cleared, this bit cannot be set. Instead, CSC is set to 1b.</p> <p>This is performed to report to ports to which no device is connected, that port reset was performed.</p>

Bit	Bit Name	Initial Value	R/W	Description
3	POCI	0	R/W	<p>The meaning of this bit differs depending on whether the operation is read or write.</p> <p>[Read] Port OverCurrent Indicator This bit indicates that the downstream port is in the overcurrent status. This bit is valid only when the setting is specified that the overcurrent status is reported for each port (OCPM bit = 1b). On the other hand, if the setting is specified that the overcurrent status is reported for all ports, this bit is always read as 0b. 0b: The port is in normal status. 1b: The port is in overcurrent status.</p> <p>[Write] Clear Suspend Status This bit is used to finish the Suspend status and start the Resume sequence. Writing 1b to this bit starts the Resume sequence. Writing 0b has no effect. The Resume sequence starts only when PSS (Port Suspend Status) is set.</p>
2	PSS	0	R/W	<p>The meaning of this bit differs depending on whether the operation is read or write.</p> <p>[Read] Port Suspend Status This bit indicates that the port status is in Suspend or Resume sequence. 0b: The port is not in Suspend status. 1b: The port is in Suspend status.</p> <p>When the CCS bit is cleared (when no device is connected), this bit cannot be set. This bit is cleared under the following conditions:</p> <ul style="list-style-type: none"> • When the Resume sequence finished, and the PSSC (Port Suspend Status Change) bit is set • When the port reset finished, and the PRSC (Port Reset Status Change) bit is set • When the host controller is in the USB Resume state <p>[Write] Set Port Suspend This bit is used to change the port status to Suspend. Writing 1b to this bit changes the status to Suspend. Writing 0b to this bit has no effect. If CCS is cleared, this bit cannot be set. Instead, CSC is set to 1b. This is performed to report to the ports to which no device is connected that the Suspend command was issued.</p>
1	PES	0	R/W	<p>The meaning of this bit differs depending on whether the operation is read or write.</p> <p>[Read] Port Enable Status This bit indicates whether the port status is Enable or Disable. If the host controller detects a bus error (for example, overcurrent state, disconnect, port power off, and babble error), it clears this bit. Then, the PESC (PortEnableStatusChange) bit is set. When the CCS bit is cleared (when no device is connected), this bit cannot be set. This bit is set "when port reset finished and the PRSC bit is set" or "when the port status becomes Suspend and the PRSC bit is set". 0b: The port status is Disable. 1b: The port status is Enable.</p> <p>[Write] Set Port Enable This bit is used to set the PES bit. Writing 1b to this bit changes the port status to Enable. Writing 0b to this bit has no effect. If CCS is cleared, this bit cannot be set. Instead, CSC is set to 1b. This is performed to report that the status of the ports to which no device is connected was tried to be changed to Enable.</p>

Bit	Bit Name	Initial Value	R/W	Description
0	CCS	0	R/W	<p>The meaning of this bit differs depending on whether the operation is read or write.</p> <p>[Read] Current Connect Status The current connection status of the downstream port is applied to this bit.</p> <p>0b: No device is connected. 1b: A device is connected.</p> <p>[Write] Clear Port Enable This bit is used to clear the PES (Port Enable Status) bit. Writing 1b to this bit changes the port status to Disable. Writing 0b to this bit has no effect.</p>

32A.2.4.2 EHCI Controller Capability Register

(1) HCIVERSION/CAPLENGTH Register

Register abbreviation: CAPL_VERSION

Bit	31	30	29	28	27	26	25	24	23	22	21	20	19	18	17	16
	Interface Version Number[15:8]								Interface Version Number[7:0]							
Initial Value	0	0	0	0	0	0	0	1	0	0	0	1	0	0	0	0
R/W	R	R	R	R	R	R	R	R	R	R	R	R	R	R	R	R
Bit	15	14	13	12	11	10	9	8	7	6	5	4	3	2	1	0
	—								Capability Registers Length[7:0]							
Initial Value	0	0	0	0	0	0	0	0	0	0	1	0	0	0	0	0
R/W	R	R	R	R	R	R	R	R	R	R	R	R	R	R	R	R

Bit	Bit Name	Initial Value	R/W	Description
31 to 16	Interface Version Number	H'0110	R	This field indicates the EHCI version supported by the host controller. H'0110 is indicated because this host controller supports EHCI Rev1.1.
15 to 8	—	All 0	R	Reserved The write value should always be 0.
7 to 0	Capability Registers Length	H'20	R	This field is used as an offset that is added to the base address to find the start address of the EHCI Operational register. H'20 is indicated because the EHCI Operation register of this module starts from H'20.

(2) HCSPARAMS Register

Register abbreviation: HCSPARAMS

Bit	31	30	29	28	27	26	25	24	23	22	21	20	19	18	17	16
	—	—	—	—	—	—	—	—	Debug Port Number [3:0]			—	—	—	P_INDICATOR	
Initial Value	0	0	0	0	0	0	0	0	0	0	0	0	0	0	0	0
R/W	R	R	R	R	R	R	R	R	R	R	R	R	R	R	R	R
Bit	15	14	13	12	11	10	9	8	7	6	5	4	3	2	1	0
	N_CC				N_PCC				Port Routing Rules	—	—	PPC	N_PORTS[3:0]			
Initial Value	0	0	0	1	0	0	0	1	1	0	0	1	0	0	0	1
R/W	R	R	R	R	R	R	R	R	R	R	R	R	R	R	R	R

Bit	Bit Name	Initial Value	R/W	Description
31 to 24	—	All 0	R	Reserved The write value should always be 0.
23 to 20	Debug Port Number	All 0	R	This field indicates that the host controller port is a debug port. 0000b is indicated because this module does not have a debug port.
19 to 17	—	All 0	R	Reserved The write value should always be 0.
16	P_INDICATOR	0	R	Port Indicators This bit indicates whether the host controller supports port indicator control. 0b is indicated because this module does not support port indicator control.
15 to 12	N_CC	H'1	R	Number of Companion Controller This field indicates the number of OHCI host controllers implemented in this module. H'1 is indicated because this module has one OHCI host controller.
11 to 8	N_PCC	H'1	R	Number of Ports per Companion Controller This field indicates the number of ports supported by an OHCI host controller. The setting value of the Port_no field of the PCI Configuration EXT1 register is applied to this field.
7	Port Routing Rules	1	R	This bit indicates how individual ports are mapped to the OHCI host controller. This bit indicates 1b because, in this module, the contents of the HCSP_PORTROUTE register show the mapping method.
6, 5	—	All 0	R	Reserved The write value should always be 0.
4	PPC	1	R	Port Power Control This bit indicates how the port power of this module is controlled. 0b: The port power is always on. 1b: The PP bit of the PORTSC register controls the port power.
3 to 0	N_PORTS	H'1	R	This field indicates the number of physical downstream ports used by this module. 0001b: 1 Port

(3) HCCPARAMS Register

Register abbreviation: HCCPARAMS

Bit	31	30	29	28	27	26	25	24	23	22	21	20	19	18	17	16
	—	—	—	—	—	—	—	—	—	—	—	—	32-Frame Periodic List Capability	Per-Port Change Event Capability	Link Power Management Capability	Hardware Prefetch Capability
Initial Value	0	0	0	0	0	0	0	0	0	0	0	0	1	1	1	0
R/W	R	R	R	R	R	R	R	R	R	R	R	R	R	R	R	R
Bit	15	14	13	12	11	10	9	8	7	6	5	4	3	2	1	0
	EECP								Isochronous Scheduling Threshold				—	Asynchronous Schedule Park Capability	Programmable Frame List Flag	64-bit Addressing Capability
Initial Value	0	0	0	0	0	0	0	0	0	0	0	0	0	1	1	0
R/W	R	R	R	R	R	R	R	R	R	R	R	R	R	R	R	R

Bit	Bit Name	Initial Value	R/W	Description
31 to 20	—	All 0	R	Reserved The write value should always be 0.
19	32-Frame Periodic List Capability	1	R	This bit indicates 1b because this module supports 32-Frame Periodic List defined in EHCI V1.1. This means that the Frame List Size field of the USBCMD register is set to 11b, so this module supports 32-Frame Periodic List.
18	Per-Port Change Event Capability	1	R	This bit indicates 1b because this module supports event detection function for ports that are defined in EHCI V1.1. This means that this module supports event detection function for ports, and is associated with the Pre-Port Change Event Enable field of the USBCMD register, Port-1 Change Detect field of the USBSTS register, and Port-1 Change Interrupt Enable field of the USBINT register. If this bit is 0b, the corresponding fields of the above registers are treated as Reserved.
17	Link Power Management Capability	1	R	This bit indicates 1b because this module supports LPM (Link Power Management) defined in EHCI V1.1. This means that this module supports LPM L1 state, and is controlled by the Suspend using L1 bit, Suspend Status bit, and Device Address field of the PORTSC register. If this bit is 0b, the corresponding bits and field of the above PORTSC register are treated as Reserved.
16	Hardware Prefetch Capability	0	R	This bit indicates 0b because this module does not support the hardware prefetch function defined in EHCI V1.1.
15 to 8	EECP	All 0	R	This field indicates the offset address of the EHCI Extend Capabilities Registers. This field indicates H'00 because this module does not use EHCI Extend Capabilities Registers.
7 to 4	Isochronous Scheduling Threshold	All 0	R	This field indicates H'0 because this module does not support caches with isochronous data structure for the entire frame.
3	—	0	R	Reserved The write value should always be 0.
2	Asynchronous Schedule Park Capability	1	R	This bit indicates whether the Park mode is supported for High Speed QH (Queue Head) in an asynchronous schedule. This bit indicates 1b because this module supports the above function.

Bit	Bit Name	Initial Value	R/W	Description
1	Programmable Frame List Flag	1	R	<p>This bit indicates the setting for the available frame list size.</p> <p>This bit indicates 1b for this module.</p> <p>If this bit is set to 1b, bit [3:2] (Frame List Size) of the USBCMD register can be used to set the available frame list size, and the frame list size smaller than 4 Kbyte is configurable.</p>
0	64-bit addressing Capability	0	R	<p>This bit indicates which type of memory pointer the data structure uses (32 bit address memory pointer or 64 bit address memory pointer).</p> <p>This bit indicates 0b for this module because this module has the data structure that uses 32 bit address memory pointer. 64 bit address is not supported.</p>

(4) HCSP-PORTROUTE Register

Register abbreviation: HCSP_PORTROUTE

Bit	31	30	29	28	27	26	25	24	23	22	21	20	19	18	17	16
	Companion Port Route[31:24]								Companion Port Route[23:16]							
Initial Value	0	0	0	0	0	0	0	0	0	0	0	0	0	0	0	0
R/W	R	R	R	R	R	R	R	R	R	R	R	R	R	R	R	R
Bit	15	14	13	12	11	10	9	8	7	6	5	4	3	2	1	0
	Companion Port Route[15:8]								Companion Port Route[7:0]							
Initial Value	0	0	0	0	0	0	0	0	0	0	0	0	0	0	0	0
R/W	R	R	R	R	R	R	R	R	R	R	R	R	R	R	R	R

Bit	Bit Name	Initial Value	R/W	Description
31 to 0	Companion Port Route[31:0]	All 0	R	This field indicates the ports controlled by the OHCI host controller. This field indicates 0b for this module because this module has one OHCI host controller.

32A.2.4.3 HCI Operational Register

(1) USBCMD Register

Register abbreviation: USBCMD

Bit	31	30	29	28	27	26	25	24	23	22	21	20	19	18	17	16
	—	—	—	—	Host-Initiated Resume Duration				Interrupt Threshold Control							
Initial Value	0	0	0	0	0	0	0	0	0	0	0	0	1	0	0	0
R/W	R	R	R	R	R/W	R/W	R/W	R/W	R	R/W	R/W	R/W	R/W	R/W	R/W	R/W
Bit	15	14	13	12	11	10	9	8	7	6	5	4	3	2	1	0
	Per-Port Change Events Enable	—	—	—	Asynchronous Schedule Park Mode Enable	—	Asynchronous Schedule Park Mode Count		—	Interrupt on Async Advance Doorbell	Asynchronous Schedule Enable	Periodic Schedule Enable	Frame List Size		HCRES ET	RS
Initial Value	0	0	0	0	1	0	1	1	0	0	0	0	0	0	0	0
R/W	R/W	R	R	R	R/W	R	R/W	R/W	R	R/W	R/W	R/W	R/W	R/W	W	R/W

Bit	Bit Name	Initial Value	R/W	Description																		
31 to 28	—	All 0	R	Reserved The write value should always be 0.																		
27 to 24	Host-Initiated Resume Duration	All 0	R/W	This field indicates the minimum time of the K-state drive while the host controller resumes from the LPM (L1) state. The value in this field is sent to the connected device that has the LPM function via the HIRD field in the bmAttributes field of the LPM token. The encoded value of this field is defined as the name of the HIRD field in the LPM Token. Specifically, H'0 means 50 μ s, and if the value is incremented by 1, 75 μ s is incremented. For example, H'1 means 125 μ s, and H'4 means 1175 μ s.																		
23 to 16	Interrupt Threshold Control	H'08	R, R/W	This field indicates the maximum rate until the host controller issues an interrupt. Note that the setting values other than the following values are not guaranteed. <table border="1"> <thead> <tr> <th>Value</th> <th>Maximum Interrupt Interval</th> </tr> </thead> <tbody> <tr> <td>H'00</td> <td>Reserved</td> </tr> <tr> <td>H'01</td> <td>1 micro-frame</td> </tr> <tr> <td>H'02</td> <td>2 micro-frames</td> </tr> <tr> <td>H'04</td> <td>4 micro-frames</td> </tr> <tr> <td>H'08</td> <td>8 micro-frames (default, equals to 1 ms)</td> </tr> <tr> <td>H'10</td> <td>16 micro-frames (2 ms)</td> </tr> <tr> <td>H'20</td> <td>32 micro-frames (4 ms)</td> </tr> <tr> <td>H'40</td> <td>64 micro-frames (8 ms)</td> </tr> </tbody> </table> Do not set H'00 to this field while the Halted bit is 0b.	Value	Maximum Interrupt Interval	H'00	Reserved	H'01	1 micro-frame	H'02	2 micro-frames	H'04	4 micro-frames	H'08	8 micro-frames (default, equals to 1 ms)	H'10	16 micro-frames (2 ms)	H'20	32 micro-frames (4 ms)	H'40	64 micro-frames (8 ms)
Value	Maximum Interrupt Interval																					
H'00	Reserved																					
H'01	1 micro-frame																					
H'02	2 micro-frames																					
H'04	4 micro-frames																					
H'08	8 micro-frames (default, equals to 1 ms)																					
H'10	16 micro-frames (2 ms)																					
H'20	32 micro-frames (4 ms)																					
H'40	64 micro-frames (8 ms)																					
15	Per-Port Change Events Enable	0	R/W	This field is used to enable the event report function of the ports defined by the Port-1 Change Detect field of the USBSTS register and the Port-1 Change Detect Enable field of the USBINTR register. 0b: The event report function of the ports is disabled. 1b: The event report function of the ports is enabled.																		
14 to 12	—	All 0	R	Reserved The write value should always be 0.																		
11	Asynchronous Schedule Park Mode Enable	1	R/W	This bit enables or disables the Asynchronous Schedule Park mode. 0b: The Park mode is disabled. 1b: The Park mode is enabled.																		

Bit	Bit Name	Initial Value	R/W	Description										
10	—	0	R	Reserved The write value should always be 0.										
9, 8	Asynchronous Schedule Park Mode Count	11b	R/W	This field sets the number of transactions that the host controller can serially execute for one QH (Queue Head) fetch in an asynchronous schedule. The valid value range is H'1 to H'3. This field is valid when bit 11 (Asynchronous Schedule Park Mode Enable) is 1b. Do not set H'0 to this field.										
7	—	0	R	Reserved The write value should always be 0.										
6	Interrupt on Async Advance Doorbell	0	R/W	This bit is used as the doorbell. In an asynchronous schedule processing, if you want an interrupt to occur before proceeding to the next QH (Queue), set this bit to 1b. After a QH processing normally finishes, the host controller clears this bit to 0b, and sets bit 5 (Interrupt on Async Advance Enable bit) of the USBSTS register to 1b. If bit 5 (Interrupt on Async Advance Enable bit) of the UBINTR register is set to 1b, an interrupt occurs at the next interrupt timing. If the asynchronous schedule is disabled, do not write 1b to this bit.										
5	Asynchronous Schedule Enable	0	R/W	This bit sets whether the host controller proceeds to the asynchronous list processing or skip the processing. 0b: The asynchronous list processing is skipped. 1b: Use the ASYNCLISTADDR register to proceed the asynchronous list processing.										
4	Periodic Schedule Enable	0	R/W	This bit sets whether the host controller proceeds or skips the periodic list processing. 0b: The periodic list processing is skipped. 1b: Use the PERIODICLISTBASE register to proceed the periodic list processing.										
3, 2	Frame List Size	0	R/W	This field specifies the frame list size. The setting value of this field determines the size of the Frame List Current index of the FRINDEX register. <table border="1" data-bbox="614 1193 1145 1361"> <thead> <tr> <th>Value</th> <th>the number of frames in Frame List</th> </tr> </thead> <tbody> <tr> <td>00b</td> <td>1024 frames (default)</td> </tr> <tr> <td>01b</td> <td>512 frames</td> </tr> <tr> <td>10b</td> <td>256 frames</td> </tr> <tr> <td>11b</td> <td>32 frames</td> </tr> </tbody> </table>	Value	the number of frames in Frame List	00b	1024 frames (default)	01b	512 frames	10b	256 frames	11b	32 frames
Value	the number of frames in Frame List													
00b	1024 frames (default)													
01b	512 frames													
10b	256 frames													
11b	32 frames													
1	HCRESET	0	W	Host Controller Reset This bit is used to initialize the EHCI circuit of the host controller. If this bit is set to 1b, the host controller initializes the internal pipelines, counters, and state machines, and communications on the USB immediately stop. At this time, port reset is not issued to the downstream ports. Reset by this bit has no effect on the registers other than the EHCI Operational register. The EHCI Operational register is initialized, and the port owner returns to OHCI. Software must be reset to return the host controller to the operational state. When this reset processing finishes, the host controller sets this bit to 0b. Writing 0b to this bit cannot stop the reset processing. If the HCHalted bit of the USBSTS register is set to 0b, do not set 1b to this bit.										
0	RS	0	R/W	Run/Stop This bit is used to run or stop the EHCI host controller. If this bit is set to 1b, the host controller starts operation. As long as this bit is set to 1b, the host controller continues running. If this bit is set to 0b, the host controller finishes the currently executing transaction and some other transactions, and then is changed to the Halt status. The HCHalted bit of the USBSTS register indicates that the host controller finished the transaction processing and entered into the stop status. If the host controller is in a status other than Halt (the HCHalted bit of the USBSTS register is 1b), do not write 1b to this bit.										

(2) USBSTS Register

Register abbreviation: USBSTS

Bit	31	30	29	28	27	26	25	24	23	22	21	20	19	18	17	16
	—	—	—	—	—	—	—	—	—	—	—	—	—	—	—	Port-1 Change Detect
Initial Value	0	0	0	0	0	0	0	0	0	0	0	0	0	0	0	0
R/W	R	R	R	R	R	R	R	R	R	R	R	R	R	R	R	R/W(1)
Bit	15	14	13	12	11	10	9	8	7	6	5	4	3	2	1	0
	Asynchronous Schedule Status	Periodic Schedule Status	Reclamation	HCHalted	—	—	—	—	—	—	Interrupt on Async Advance	Host System Error	Frame List Rollover	Port Change Detect	USBER RINT	USBINT
Initial Value	0	0	0	1	0	0	0	0	0	0	0	0	0	0	0	0
R/W	R	R	R	R	R	R	R	R	R	R	R/W(1)	R/W(1)	R/W(1)	R/W(1)	R/W(1)	R/W(1)

Bit	Bit Name	Initial Value	R/W	Description
31 to 17	—	All 0	R	Reserved The write value should always be 0.
16	Port-1Change Detect	0	R/W (1)	If this bit is set to 1b, it indicates that a change in the port status was detected. This bit is used only when the Per-Port Change Events Enable bit of the USBCMD register is set to 1b.
15	Asynchronous Schedule Status	0	R	This bit indicates the current status of the asynchronous schedule. 0b: The asynchronous schedule is disabled. 1b: The asynchronous schedule is enabled. If this bit and bit 5 (Asynchronous Schedule Enable) of the USBCMD register have the same value, the asynchronous schedule is enabled (1b) or disabled (0b).
14	Periodic Schedule Status	0	R	This bit indicates the current status of the periodic schedule. 0b: The periodic schedule is disabled. 1b: The periodic schedule is enabled. If this bit and bit 4 (Periodic Schedule Enable) of the USBCMD register have the same value, the periodic schedule is enabled (1b) or disabled (0b).
13	Reclamation	0	R	This bit is used to detect an empty asynchronous schedule. If this bit is 1b, the asynchronous schedule is empty. After reset or when a QH (H = 1) is fetched, the host controller clears this bit to 0b. Also, when the host controller executes an asynchronous transaction or detects a start event, it sets this bit to 1b. If this bit is 0b and a QH (H = 1) is fetched, the host controller is entered into the Async Sched Sleeping mode.
12	HCHalted	1	R	If the Run/Stop bit of the USBCMD register is 1b, this bit indicates 0b. If the software or host controller sets the Run/Stop bit to 0b, the host controller stops operation, and sets 1b to this bit. 0b: The EHCI host controller is running. 1b: The EHCI host controller is stopped.
11 to 6	—	All 0	R	Reserved The write value should always be 0.

Bit	Bit Name	Initial Value	R/W	Description
5	Interrupt on Async Advance	0	R/W (1)	<p>This bit indicates the Async Advance Interrupt status.</p> <p>After the host controller fetches the QH, it checks bit 6 (Interrupt on Async Advance Doorbell [IAAD] bit) of the USBCMD Register. If the IAAD bit is set to 1b, the host controller clears the IAAD bit after the QH processing normally finishes, and sets this bit.</p> <p>If bit 5 (Interrupt on Async Advance Enable bit) of the UBINTR register is set to 1b, an interrupt due to this source will occur at the next interrupt timing after 1b is set to this bit.</p> <p>If HCD writes 1b to this bit, this bit can be cleared. Writing 0b to this bit has no effect.</p> <p>0b: Async Advance Interrupt not occurred. 1b: Async Advance Interrupt status is detected.</p>
4	Host System Error	0	R/W (1)	<p>This bit is set to 1b if a serious error occurs in the host controller.</p> <p>If this error occurs, the host controller clears the Run/Stop bit of the USBCMD register to 0b so that the subsequent schedules are not executed.</p> <p>Writing 1b to this bit can clear this bit. Writing 0b to this bit has no effect.</p> <p>0b: No system error occurred. 1b: A system error occurred.</p>
3	Frame List Rollover	0	R/W (1)	<p>If a frame list rollover occurs, the host controller sets this bit to 1b.</p> <p>Specifically, when the Frame Index field of the FRINDEX register is returned to H'000 from the maximum value (rollover), the host controller sets this bit to 1b. The maximum value (the value at which rollover occurs) depends on the Frame List Size field of the USBCMD register.</p> <p>For example, if the Frame List Size is 1024 frame, rollover occurs every time FRINDEX [13] toggles. If the Frame List Size is 512 frame, rollover occurs every time FRINDEX [12] toggles.</p> <p>If the Frame List Size is 256 frame, rollover occurs every time FRINDEX [11] toggles.</p> <p>Writing 1b to this bit can clear this bit. Writing 0b to this bit has no effect.</p> <p>0b: The frame list is not returned to H'000. 1b: The frame list is returned to H'000 (rollover occurred).</p>
2	Port Change Detect	0	R/W (1)	<p>This bit indicates that the port status has changed.</p> <p>Among the ports for which the Port Owner bit of the PORTSC1 register is set to 0b, if any port satisfies one of the following conditions, the host controller sets this bit to 1b:</p> <ul style="list-style-type: none"> • Connect or Disconnect status of a device is detected, and the Connect Status Change bit of the PORTSC1 register is changed from 0 to 1. • A change of the Enable status of the port is detected, and the Port Enable/Disable Change bit of the PORTSC1 register is changed from 0 to 1. • The overcurrent state is detected, and the Over-current Change bit of the PORTSC1 register is changed from 0 to 1. • J-K transition is detected on a port in the Suspend status, and the Force Port Resume bit of the PORTSC1 register is changed from 0 to 1. <p>Writing 1b to this bit can clear this bit. Writing 0b to this bit has no effect.</p>
1	USBERRINT	0	R/W (1)	<p>USB Error Interrupt</p> <p>This bit indicates that a USB transaction finished with an error.</p> <p>When a USB transaction finishes with an error, the host controller sets this bit to 1b.</p> <p>If 1b is set to the IOC bit of qTD at which an error interrupt occurred, 1b is set to both of this bit and USBINT bit.</p> <p>Writing 1b to this bit can clear this bit. Writing 0b to this bit has no effect.</p> <p>0b: USB transaction is normal. 1b: USB transaction finished with an error.</p>

Bit	Bit Name	Initial Value	R/W	Description
0	USBINT	0	R/W (1)	<p>USB Interrupt</p> <p>This bit indicates that a USB transfer has finished.</p> <p>The host controller sets this bit to 1b if one of the following conditions is satisfied:</p> <ul style="list-style-type: none">• A USB transfer has finished.• A short packet is received. <p>Even if a USB transfer finished with an error, if IOC (Interrupt On Complete) of the TD is set to 1b, this bit is set to 1b.</p> <p>Writing 1b to this bit can clear this bit. Writing 0b to this bit has no effect.</p> <p>0b: A USB transfer has not finished. 1b: A USB transfer has finished.</p>

(3) USBINTR Register

Register abbreviation: USBINTR

Bit	31	30	29	28	27	26	25	24	23	22	21	20	19	18	17	16
	—	—	—	—	—	—	—	—	—	—	—	—	—	—	—	Port-1 Change Event Enable
Initial Value	0	0	0	0	0	0	0	0	0	0	0	0	0	0	0	0
R/W	R	R	R	R	R	R	R	R	R	R	R	R	R	R	R	R/W
Bit	15	14	13	12	11	10	9	8	7	6	5	4	3	2	1	0
	—	—	—	—	—	—	—	—	—	—	Interrupt on Async Advance Enable	Host System Error Enable	Frame List Rollover Enable	Port Change Detect Enable	USB Error Interrupt Enable	USB Interrupt Enable
Initial Value	0	0	0	0	0	0	0	0	0	0	0	0	0	0	0	0
R/W	R	R	R	R	R	R	R	R	R	R	R/W	R/W	R/W	R/W	R/W	R/W

Bit	Bit Name	Initial Value	R/W	Description
31 to 17	—	All 0	R	Reserved The write value should always be 0.
16	Port-1 Change Event Enable	0	R/W	If this bit is 1b and the Port Change Detect bit of the USBSTS register is set to 1b, the host controller issues an interrupt.
15 to 6	—	All 0	R	Reserved The write value should always be 0.
5	Interrupt on Async Advance Enable	0	R/W	This bit sets whether bit 5 (Interrupt on Async Advance [IAA] bit) of the USBSTS register is enabled or disabled. If the IAA bit is set to 1b while this bit is set to 1b, the host controller issues an interrupt at the next interrupt timing. 0b: Disabled. 1b: Enabled (an interrupt occurs via the IAA bit).
4	Host System Error Enable	0	R/W	This bit sets whether bit 4 (Host System Error [HSE] bit) of the USBSTS register is enabled or disabled. If the HSE bit is set to 1b while this bit is set to 1b, the host controller issues an interrupt at the next interrupt timing. 0b: Disabled. 1b: Enabled (an interrupt occurs via the HSE bit).
3	Frame List Rollover Enable	0	R/W	This bit sets whether the bit 3 (Frame List Rollover [FLR] bit) of the USBSTS register is enabled or disabled. If the FLR bit is set to 1b while this bit is set to 1b, the host controller issues an interrupt at the next interrupt timing. 0b: Disabled. 1b: Enabled (an interrupt occurs via the FLR bit).
2	Port Change Detect Enable	0	R/W	This bit sets whether bit 2 (Port Change Detect [PCD] bit) of the USBSTS register is enabled or disabled. If the USBERRINT bit is set to 1b while this bit is set to 1b, the host controller issues an interrupt at the next interrupt timing. 0b: Disabled. 1b: Enabled (an interrupt occurs via the PCD bit).
1	USB Error Interrupt Enable	0	R/W	This bit sets whether bit 1 (USBERRINT bit) of the USBSTS register is enabled or disabled. If the USBERRINT bit is set to 1b while this bit is set to 1b, the host controller issues an interrupt at the next interrupt timing. 0b: Disabled. 1b: Enabled (an interrupt occurs via the USBERRINT bit).

Bit	Bit Name	Initial Value	R/W	Description
0	USB Interrupt Enable	0	R/W	<p>This bit sets whether bit 0 (USBINT bit) of the USBSTS register is enabled or disabled.</p> <p>If the USBINT bit is set to 1b while this bit is set to 1b, the host controller issues an interrupt at the next interrupt timing.</p> <p>0b: Disabled.</p> <p>1b: Enabled (an interrupt occurs via the USBINT bit).</p>

(4) FRINDEX Register

Register abbreviation: FRINDEX

Bit	31	30	29	28	27	26	25	24	23	22	21	20	19	18	17	16
	—	—	—	—	—	—	—	—	—	—	—	—	—	—	—	—
Initial Value	0	0	0	0	0	0	0	0	0	0	0	0	0	0	0	0
R/W	R	R	R	R	R	R	R	R	R	R	R	R	R	R	R	R
Bit	15	14	13	12	11	10	9	8	7	6	5	4	3	2	1	0
	—	—	Frame Index[13:8]						Frame Index[7:0]							
Initial Value	0	0	0	0	0	0	0	0	0	0	0	0	0	0	0	0
R/W	R	R	R/W	R/W	R/W	R/W	R/W	R/W	R/W	R/W	R/W	R/W	R/W	R/W	R/W	R/W

Bit	Bit Name	Initial Value	R/W	Description															
31 to 14	—	All 0	R	Reserved The write value should always be 0.															
13 to 0	Frame Index[13:0]	All 0	R/W	<p>This field is used by the host controller to add an index to the periodic frame list. The value in this field is incremented at the end of a micro frame.</p> <p>Bit [N:3] of this field is used as the Frame List Current index. This means that, before the next index arrives, the current frame list is accessed 8 times. The value for N is determined, as follows, by the setting value of bit [3:2] (Frame List Size field) of the USBCMD register.</p> <table border="1"> <thead> <tr> <th>Frame List Size</th> <th>Number of Frames</th> <th>N</th> </tr> </thead> <tbody> <tr> <td>00b</td> <td>1024</td> <td>12</td> </tr> <tr> <td>01b</td> <td>512</td> <td>11</td> </tr> <tr> <td>10b</td> <td>256</td> <td>10</td> </tr> <tr> <td>11b</td> <td>32</td> <td>12</td> </tr> </tbody> </table> <p>Access this register only when the host controller is in stop status (bit 12 [HCHalted] = 1b). The setting value of this field is applied to the SOF frame number of the SOF token.</p>	Frame List Size	Number of Frames	N	00b	1024	12	01b	512	11	10b	256	10	11b	32	12
Frame List Size	Number of Frames	N																	
00b	1024	12																	
01b	512	11																	
10b	256	10																	
11b	32	12																	

(5) CTRLDSSEGMENT Register

Register abbreviation: CTRLDSSEGMENT

Bit	31	30	29	28	27	26	25	24	23	22	21	20	19	18	17	16
	CTRLDSSEGMENT[31:24]								CTRLDSSEGMENT[23:16]							
Initial Value	0	0	0	0	0	0	0	0	0	0	0	0	0	0	0	0
R/W	R	R	R	R	R	R	R	R	R	R	R	R	R	R	R	R
Bit	15	14	13	12	11	10	9	8	7	6	5	4	3	2	1	0
	CTRLDSSEGMENT[15:8]								CTRLDSSEGMENT[7:0]							
Initial Value	0	0	0	0	0	0	0	0	0	0	0	0	0	0	0	0
R/W	R	R	R	R	R	R	R	R	R	R	R	R	R	R	R	R

Bit	Bit Name	Initial Value	R/W	Description
31 to 0	CTRLDSSEGMENT	All 0	R	This register is not used because this module does not support 64-bit address method. Therefore, HCD must not access this register.

(6) PERIODICLISTBASE Register

Register abbreviation: PERIODICLISTBASE

Bit	31	30	29	28	27	26	25	24	23	22	21	20	19	18	17	16
	Base Address[31:24]								Base Address[23:16]							
Initial Value	0	0	0	0	0	0	0	0	0	0	0	0	0	0	0	0
R/W	R/W	R/W	R/W	R/W	R/W	R/W	R/W	R/W	R/W	R/W	R/W	R/W	R/W	R/W	R/W	R/W
Bit	15	14	13	12	11	10	9	8	7	6	5	4	3	2	1	0
	Base Address[15:12]				—	—	—	—	—	—	—	—	—	—	—	—
Initial Value	0	0	0	0	0	0	0	0	0	0	0	0	0	0	0	0
R/W	R/W	R/W	R/W	R/W	R	R	R	R	R	R	R	R	R	R	R	R

Bit	Bit Name	Initial Value	R/W	Description
31 to 12	Base Address	All 0	R/W	<p>This field indicates the head address of the periodic frame list on the system memory. The host controller loads the contents of this register before starting the list processing.</p> <p>The host controller determines the frame list to be processed by using this field and Frame Index of the FRINDEX register.</p> <p>Align the address of the periodic frame list by 4 Kbyte.</p> <p>Normal operation is not guaranteed if any of these bits are changed during operation.</p>
11 to 0	—	All 0	R	<p>Reserved</p> <p>The write value should always be 0.</p>

(7) ASYNCLISTADDR Register

Register abbreviation: ASYNCLISTADDR

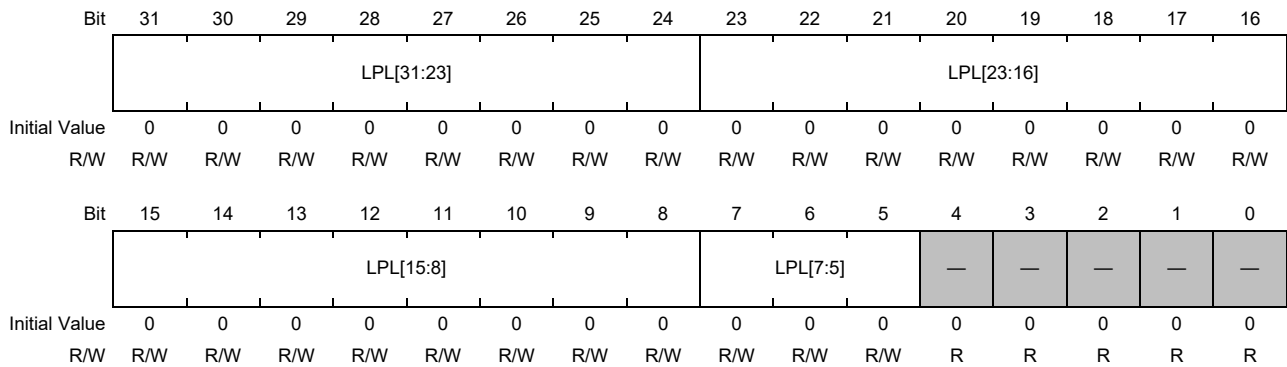

Bit	Bit Name	Initial Value	R/W	Description
31 to 5	LPL	All 0	R/W	Link Pointer Low This field indicates the address (on the system memory) of the Asynchronous Queue Head to be processed next time. Align the address of Asynchronous Queue Head by 32 byte.
4 to 0	—	All 0	R	Reserved The write value should always be 0.

(8) CONFIGFLAG Register

Register abbreviation: CONFIGFLAG

Bit	31	30	29	28	27	26	25	24	23	22	21	20	19	18	17	16
	—	—	—	—	—	—	—	—	—	—	—	—	—	—	—	—
Initial Value	0	0	0	0	0	0	0	0	0	0	0	0	0	0	0	0
R/W	R	R	R	R	R	R	R	R	R	R	R	R	R	R	R	R
Bit	15	14	13	12	11	10	9	8	7	6	5	4	3	2	1	0
	—	—	—	—	—	—	—	—	—	—	—	—	—	—	—	CF
Initial Value	0	0	0	0	0	0	0	0	0	0	0	0	0	0	0	0
R/W	R	R	R	R	R	R	R	R	R	R	R	R	R	R	R	R/W

Bit	Bit Name	Initial Value	R/W	Description
31 to 1	—	All 0	R	Reserved The write value should always be 0.
0	CF	0	R/W	Configuration Flag This bit controls which of OHCI or EHCI is routed by the port routing control circuit by default. At the end of the host controller configuration, this bit is set to 1b. 0b: The port routing control circuit routes each port to the OHCI host controller by default. 1b: The port routing control circuit routes each port to the EHCI host controller by default.

(9) PORTSC1 Register

Register abbreviation: PORTSC1

Bit	31	30	29	28	27	26	25	24	23	22	21	20	19	18	17	16
	Device Address							Suspend Status[1]	Suspend Status[0]	WKOC_E	WKDSCNNT_E	WKCNNNT_E	Port Test Control			
Initial Value	0	0	0	0	0	0	0	0	0	0	0	0	0	0	0	0
R/W	R/W	R/W	R/W	R/W	R/W	R/W	R/W	R	R	R/W	R/W	R/W	R/W	R/W	R/W	R/W
Bit	15	14	13	12	11	10	9	8	7	6	5	4	3	2	1	0
	—	—	Port Owner	PP	Line Status	Suspend using L1	Port Reset	Suspend	Force Port Resume	Overcurrent Active Change	Overcurrent Active	Port Enabled/Disabled Change	Port Enabled/Disabled	Connect Status Change	Current Connect Status	
Initial Value	0	0	1	0	0	0	0	0	0	0	0	0	0	0	0	0
R/W	R	R	R/W	R/W	R	R	R/W	R/W	R/W	R/W	R/W(1)	R	R/W(1)	R/W	R/W(1)	R

Bit	Bit Name	Initial Value	R/W	Description
31 to 25	Device Address	All 0	R/W	This field indicates the USB device address (7 bits) of the device connected to the down port. This address is used when the LPM Token is sent. If the value of this field is H'00, it means that no device that needs to use this field has been connected.
24, 23	Suspend Status	All 0	R	This field indicates the response from the connected device to the LPM Token (L1 transition request). 00b: The device succeeded transition to the L1 state (ACK received from the device). 01b: The device has not changed to the L1 state (NYET received from the device). 10b: The device does not support the L1 state transition (STALL received from the device). 11b: Other response (for example, Timeout error) Change this field only when the Suspend bit is 0b.
22	WKOC_E	0	R/W	Wake on Overcurrent Enable By writing 1b to this bit, the overcurrent state can be detected as an EHCI Wakeup event. If bit 12 (PP [Port Power] bit) is 0b, this bit becomes 0b.
21	WKDSCNNT_E	0	R/W	Wake on Disconnect Enable By writing 1b to this bit, device disconnection can be detected as an EHCI Wakeup event. If bit 12 (PP [Port Power] bit) is 0b, this bit becomes 0b.
20	WKCNNNT_E	0	R/W	Wake on Connect Enable By writing 1b to this bit, device connection can be detected as an EHCI Wakeup event. If bit 12 (PP [Port Power] bit) is 0b, this bit becomes 0b.

Bit	Bit Name	Initial Value	R/W	Description																				
19 to 16	Port Test Control	All 0	R/W	<p>This field is controlled by the test mode.</p> <p>If the value of this field is other than 0000b, it indicates that this module is running in the test mode.</p> <table border="1"> <thead> <tr> <th>Value</th> <th>Test mode</th> </tr> </thead> <tbody> <tr> <td>0000b</td> <td>Test mode not enabled</td> </tr> <tr> <td>0001b</td> <td>Test J_STATE</td> </tr> <tr> <td>0010b</td> <td>Test K_STATE</td> </tr> <tr> <td>0011b</td> <td>Test SE0_NAK</td> </tr> <tr> <td>0100b</td> <td>Test Packet</td> </tr> <tr> <td>0101b</td> <td>Test FORCE_ENABLE</td> </tr> <tr> <td>Other</td> <td>Reserved</td> </tr> </tbody> </table>	Value	Test mode	0000b	Test mode not enabled	0001b	Test J_STATE	0010b	Test K_STATE	0011b	Test SE0_NAK	0100b	Test Packet	0101b	Test FORCE_ENABLE	Other	Reserved				
Value	Test mode																							
0000b	Test mode not enabled																							
0001b	Test J_STATE																							
0010b	Test K_STATE																							
0011b	Test SE0_NAK																							
0100b	Test Packet																							
0101b	Test FORCE_ENABLE																							
Other	Reserved																							
15, 14	—	All 0	R	<p>Reserved</p> <p>The write value should always be 0.</p>																				
13	Port Owner	1	R/W	<p>This bit indicates which of OHCI or EHCI has the port ownership.</p> <p>0b: EHCI has the port ownership.</p> <p>1b: OHCI has the port ownership.</p> <p>When bit 0 (Configure Flag bit) of the CONFIGFLA register is changed from 0b to 1b, this bit becomes 0b. If bit 0 (Configure Flag bit) of the CONFIGFLA register is 0b, this bit becomes 1b.</p> <p>If the connected device is not a High Speed device, this bit is set to 1b to transfer the port ownership to OHCI.</p>																				
12	PP	0	R/W	<p>Port Power</p> <p>This bit controls power supply to the port.</p> <p>If this bit is 0b, power is not supplied to the port. Therefore, the port does not function, and does not recognize connection and disconnection.</p> <p>If overcurrent is detected while this bit is set to 1b, the host controller clears this bit to 0b, and the power supplied to the port is stopped.</p> <p><i>Note:</i> As described later, if the PPC bit is 0b, this bit is fixed to 1b, so the power supplied to the port is not stopped.</p> <p>The function of this bit differs depending on the value of bit 4 (PPC [Port Power Control] bit) of the HCSPARAMS register.</p> <table border="1"> <thead> <tr> <th>PPC</th> <th>PP</th> <th>Operation</th> </tr> </thead> <tbody> <tr> <td>0b</td> <td>1b</td> <td>R This bit is fixed to 1b, and the power is always supplied to the port.</td> </tr> <tr> <td>1b</td> <td>0b/1b</td> <td>R/W Whether or not power is supplied to the port depends on the setting of this bit.</td> </tr> <tr> <td></td> <td>0b</td> <td>Power is not supplied to the port.</td> </tr> <tr> <td></td> <td>1b</td> <td>Power is supplied to the port.</td> </tr> </tbody> </table>	PPC	PP	Operation	0b	1b	R This bit is fixed to 1b, and the power is always supplied to the port.	1b	0b/1b	R/W Whether or not power is supplied to the port depends on the setting of this bit.		0b	Power is not supplied to the port.		1b	Power is supplied to the port.					
PPC	PP	Operation																						
0b	1b	R This bit is fixed to 1b, and the power is always supplied to the port.																						
1b	0b/1b	R/W Whether or not power is supplied to the port depends on the setting of this bit.																						
	0b	Power is not supplied to the port.																						
	1b	Power is supplied to the port.																						
11, 10	Line Status	All 0	R	<p>This field indicates the logical level of D+/D- lines of the current USB bus. (bit 11: DP / bit 10: DM)</p> <p>This field is used to detect an LS device before starting a sequence for port reset and port enable.</p> <p>Therefore, this bit is valid only when bit 3 (Port Enable/Disable bit) is 0b and bit 0 (Current Connect Status bit) is 1b.</p> <table border="1"> <thead> <tr> <th>bit 11</th> <th>bit 10</th> <th>USB bus status</th> <th>Description</th> </tr> </thead> <tbody> <tr> <td>0b</td> <td>0b</td> <td>SE0</td> <td>The device is not an LS device. EHCI port reset is executing.</td> </tr> <tr> <td>1b</td> <td>0b</td> <td>J-state</td> <td>The device is not an LS device. EHCI port reset is executing.</td> </tr> <tr> <td>0b</td> <td>1b</td> <td>K-state</td> <td>An LS device was connected. The port ownership is transferred from EHCI to OHCI.</td> </tr> <tr> <td>1b</td> <td>1b</td> <td>Undefined</td> <td>The device is not an LS device. EHCI port reset is executing.</td> </tr> </tbody> </table>	bit 11	bit 10	USB bus status	Description	0b	0b	SE0	The device is not an LS device. EHCI port reset is executing.	1b	0b	J-state	The device is not an LS device. EHCI port reset is executing.	0b	1b	K-state	An LS device was connected. The port ownership is transferred from EHCI to OHCI.	1b	1b	Undefined	The device is not an LS device. EHCI port reset is executing.
bit 11	bit 10	USB bus status	Description																					
0b	0b	SE0	The device is not an LS device. EHCI port reset is executing.																					
1b	0b	J-state	The device is not an LS device. EHCI port reset is executing.																					
0b	1b	K-state	An LS device was connected. The port ownership is transferred from EHCI to OHCI.																					
1b	1b	Undefined	The device is not an LS device. EHCI port reset is executing.																					

Bit	Bit Name	Initial Value	R/W	Description												
9	Suspend using L1	0	R/W	<p>Suspend using L1 (LPM) control bit.</p> <p>If 1b is written to the Suspend bit (bit 7) while this bit is 1b, the state of this module is changed to the LPM state.</p> <p>Writing to this bit is possible only when the Suspend bit (bit 7) is 0b.</p> <p>0b: Suspend using L2 1b: Suspend using L1 (LPM)</p> <p>If this bit is 1b and the Device Address field is other than H'0000, when the Suspend bit is set to 1b, the host controller generates an LPM Token to change the state to the L1 state.</p> <p>If this bit is 0b, the host controller operates as L2 Suspend.</p>												
8	Port Reset	0	R/W	<p>This bit indicates the reset status of the port.</p> <p>0b: The port is not being reset. 1b: The port is being reset.</p> <p>If 1b is written to this bit while this bit is 0b, the bus reset sequence defined in USB 2.0 standard starts. To finish the bus reset sequence, 0b must be written to this bit. Note that this bit must remain 1b long time enough to guarantee that the bus reset sequence defined in USB 2.0 standard will be complete.</p> <p>If bit 12 (HCHalted) of the USBSTS register is 1b, do not set this bit to 1b.</p> <p>If any of the PP (Port Power) bit, Port Owner bit, and Current Connect Status bit is in the following status, this bit becomes 0b.</p> <p><i>Note:</i> Even if 1b is written to this bit, the bus reset sequence does not start.</p> <ul style="list-style-type: none"> • PP (Port Power) bit = 0b • Port Owner bit = 1b • Current Connect Status bit = 0b 												
7	Suspend	0	R/W	<p>This bit indicates the Suspend control and status of the port.</p> <p>This bit and bit 2 (Port Enabled/Disabled bit) indicate the following port status.</p> <table border="1"> <thead> <tr> <th>Port Enabled</th> <th>Suspend</th> <th>Port Status</th> </tr> </thead> <tbody> <tr> <td>0b</td> <td>—</td> <td>Disable</td> </tr> <tr> <td>1b</td> <td>0b</td> <td>Enable</td> </tr> <tr> <td></td> <td>1b</td> <td>Suspend</td> </tr> </tbody> </table> <p>To change the port state to L1 or L2 Suspend, set this bit to 1b.</p> <p>Whether the host controller supports L1 Suspend state or L2 Suspend state depends on the value in the Suspend Using L1 bit.</p> <p>In the Suspend state, data transfer to the downstream port is blocked by this port (except for port reset). If this bit is set to 1b during data transfer, blocking of transfer data does not occur until the current data transfer finishes.</p> <p>Writing 0b to this bit has no effect.</p> <p>This bit can be set to 1b only when all the following conditions are satisfied: "PP (Port Power) bit = 1b", "Port Owner bit = 0b", and "Current Connect Status bit = 1b". If any of the following conditions is satisfied, the host controller clears this bit:</p> <ul style="list-style-type: none"> • "Resume is complete" is detected. • The PR bit is set to 1b when PR (Port Reset) bit is 0b. • The port owner is 1b (OHCI). • The PP (Port Power) bit is set to 0b. • The Port Enabled/Disabled bit is set to 0b. 	Port Enabled	Suspend	Port Status	0b	—	Disable	1b	0b	Enable		1b	Suspend
Port Enabled	Suspend	Port Status														
0b	—	Disable														
1b	0b	Enable														
	1b	Suspend														

Bit	Bit Name	Initial Value	R/W	Description
6	Force Port Resume	0	R/W	<p>This bit indicates that the Resume state of the port is detected.</p> <p>0b: Resume signal is not detected or output. 1b: Resume (K-state) is detected or output.</p> <p>When the port is in Suspend state, if the host controller detects transition of the state from J to K (if RemoteWakeup is detected from the connected device), it sets this bit to 1b. The host controller also sets the Port Change Detect bit or Port-1 Changes Detect bit of the USBSTS register to 1b.</p> <p>If this bit is set to 1b, the host controller does not set 1b to the Port Change Detect bit and Port-1 Changes Detect bit of the USBSTS register. While this bit is 1b, the Resume signal (FS K) is driven onto the USB bus.</p> <p>For L2 transition, this bit must be cleared to 0b after an appropriate time has passed. By writing 0b to this bit while this bit is 1b, the port status is recovered to be the HS Idle status. This bit remains 1b until the port is recovered. The host controller must finish transition to the HS Idle state within 2msec since this bit is cleared to 0b.</p> <p>On the other hand, for L1 transition, the host controller sends a Resume signal at necessary timing, and this bit is cleared to 0b at Resume recovery. Note that the software sets the length of the Resume signal driven by the host controller, by using the Host-Initiated Resume Duration field of the USBCMD register.</p> <p>If the Port Power (PP) bit is 0b, this bit becomes 0b.</p>
5	Over-current Change	0	R/W (1)	<p>This bit indicates that bit 4 (Over-current Active bit) has changed.</p> <p>Writing 1b to this bit can clear this bit. Writing 0b to this bit has no effect.</p> <p>0b: Over-current Active bit has not changed. 1b: Over-current Active bit has changed.</p>
4	Over-current Active	0	R	<p>This bit indicates the overcurrent status of the port.</p> <p>If the host controller detects overcurrent, it disables the port, and set this bit to 1b. After the overcurrent state is released, the host controller automatically clears this bit from 1b to 0b.</p> <p>0b: The port is not in overcurrent state. 1b: The port is in overcurrent state.</p>
3	Port Enable/Disable Change	0	R/W (1)	<p>This bit indicates that the host controller detected frame babble.</p> <p>If the Host Controller detects frame babble, it disables the port and sets this bit to 1b. Writing 1b to this bit can clear this bit. Writing 0b to this bit has no effect. If the Port Power (PP) bit is 0b, this bit becomes 0b.</p> <p>0b: Frame babble has not occurred. 1b: Frame babble is detected.</p>
2	Port Enabled/Disabled	0	R/W	<p>This bit indicates the Enable/Disable status of the port.</p> <p>The host controller resets the port, and enables the port if the connected device is recognized as an HS device, and sets this bit to 1b. The software cannot set this bit to 1b.</p> <p>If the host controller detects disconnection of a device or other errors, it disables the port, and clears this bit to 0b. The port also becomes disabled when 0b is written to this bit.</p> <p>If the port is disabled, data transfer to the downstream port is blocked except for port reset.</p> <p>If Port Test Control [3:0] = 0101b (Test FORCE_ENABLE), the port becomes enabled, and this bit is set to 1b.</p> <p>If the Port Power (PP) bit is 0b, this bit becomes 0b.</p> <p>0b: The port is disabled. 1b: The port is enabled.</p>
1	Connect Status Change	0	R/W (1)	<p>This bit indicates that bit 0 (Current Connect Status bit) has changed.</p> <p>Writing 1b to this bit can clear this bit. Writing 0b to this bit has no effect.</p> <p>If the Port Power (PP) bit is 0b, this bit becomes 0b.</p> <p>0b: The Current Connect Status bit has no change. 1b: The Current Connect Status bit has changed.</p>

Bit	Bit Name	Initial Value	R/W	Description
0	Current Connect Status	0	R	<p>This bit indicates the connection status of the port.</p> <p>If the host controller detects connection of a device, it sets this bit to 1b. Also, if Port Test Control [3:0] = 0101b (Test FORCE_ENABLE), the Host Controller sets this bit to 1b even if no device is connected.</p> <p>On the other hand, if the host controller detects disconnection of a device, it sets this bit to 0b.</p> <p>If the Port Power (PP) bit is 0b, or the Port Owner (PO) bit is 0b, this bit becomes 0b.</p> <p>0b: No device is connected to the port. 1b: A device is connected to the port.</p>

32A.2.4.4 AHB Bridge Register

(1) INT_ENABLE Register

Abbreviated name of register: INT_ENABLE

Bit	31	30	29	28	27	26	25	24	23	22	21	20	19	18	17	16
	—	—	—	—	—	—	—	—	—	—	—	—	—	—	—	—
Initial Value	0	0	0	0	0	0	0	0	0	0	0	0	0	0	0	0
R/W	R	R	R	R	R	R	R	R	R	R	R	R	R	R	R	R
Bit	15	14	13	12	11	10	9	8	7	6	5	4	3	2	1	0
	—	—	—	—	—	—	—	—	—	—	—	WAKEON_INTEN	UCOM_INTEN	USBH_INTBEN	USBH_INTAEN	AHB_INTEN
Initial Value	0	0	0	0	0	0	0	0	0	0	0	0	0	0	0	0
R/W	R	R	R	R	R	R	R	R	R	R	R	R/W	R/W	R/W	R/W	R/W

Bit	Bit Name	Initial Value	R/W	Description
31 to 5	—	All 0	R	Reserved The write value should always be 0.
4	WAKEON_INTEN	0	R/W	This bit enables or disables bit 4 (WAKEON_INT) of the INT_STATUS register. 0b: disable 1b: enable
3	UCOM_INTEN	0	R/W	This bit enables or disables bit 3 (UCOM_INT) of the INT_STATUS register. 0b: disable 1b: enable
2	USBH_INTBEN	0	R/W	This bit enables or disables bit 2 (USBH_INTB) of the INT_STATUS register. 0b: disable 1b: enable
1	USBH_INTAEN	0	R/W	This bit enables or disables bit 1 (USBH_INTA) of the INT_STATUS register. 0b: disable 1b: enable
0	AHB_INTEN	0	R/W	This bit enables or disables bit 0 (AHB_INT) of the INT_STATUS register. 0b: disable 1b: enable

(2) INT_STATUS Register

Abbreviated name of register: INT_STATUS

Bit	31	30	29	28	27	26	25	24	23	22	21	20	19	18	17	16
	—	—	—	—	—	—	—	—	—	—	—	—	—	—	—	—
Initial Value	0	0	0	0	0	0	0	0	0	0	0	0	0	0	0	0
R/W	R	R	R	R	R	R	R	R	R	R	R	R	R	R	R	R
Bit	15	14	13	12	11	10	9	8	7	6	5	4	3	2	1	0
	—	—	—	—	—	—	—	—	—	—	—	WAKEON_INT	UCOM_INT	USBH_INTB	USBH_INTA	AHB_INT
Initial Value	0	0	0	0	0	0	0	0	0	0	0	0	0	0	0	0
R/W	R	R	R	R	R	R	R	R	R	R	R	R/W(1)	R	R	R	R/W(1)

Bit	Bit Name	Initial Value	R/W	Description
31 to 5	—	All 0	R	Reserved The write value should always be 0.
4	WAKEON_INT	0	R/W (1)	This bit indicates the state of WAKEON interrupt from the HOST module. Writing 1b to this bit can clear this bit. 0b: No WAKEON interrupt 1b: WAKEON interrupt
3	UCOM_INT	0	R	This bit indicates the state of interrupt from the UCOM register. To clear the interrupt, use the UCOM2 Register. 0b: No UCOM register interrupt 1b: UCOM register interrupt
2	USBH_INTB	0	R	This bit indicates the state of EHCI interrupt. To clear the interrupt, use the USBSTS Register (of the EHCI Operational Register). 0b: No INTB interrupt 1b: INTB interrupt
1	USBH_INTA	0	R	This bit indicates the state of OHCI interrupt. To clear the interrupt, use the HcInterruptStatus Register (of the OHCI Operational Register). 0b: No INTA interrupt 1b: INTA interrupt
0	AHB_INT	0	R/W (1)	This bit indicates that a BUS Master error occurred. Writing 1b to this bit can clear this bit. 0b: No bus error occurred. 1b: A bus error occurred.

(3) AHB_BUS_CTR Register

Abbreviated name of register: AHB_BUS_CTR

Bit	31	30	29	28	27	26	25	24	23	22	21	20	19	18	17	16
	—	—	—	—	—	—	—	—	—	—	—	—	—	—	—	—
Initial Value	0	0	0	0	0	0	0	0	0	0	0	0	0	0	0	0
R/W	R	R	R	R	R	R	R	R	R	R	R	R	R	R	R	R
Bit	15	14	13	12	11	10	9	8	7	6	5	4	3	2	1	0
	PROT_TYPE			—	—	—	PROT_MODE	—	—	ALIGN_ADDRESSES		—	—	MAX_BURST_LEN		
Initial Value	0	0	0	0	0	0	0	0	0	0	0	0	0	0	0	0
R/W	R/W	R/W	R/W	R/W	R/W	R	R	R	R/W	R	R	R/W	R/W	R	R	R/W

Bit	Bit Name	Initial Value	R/W	Description
31 to 16	—	All 0	R	Reserved The write value should always be 0.
15 to 12	PROT_TYPE	All 0	R/W	This field sets MHPROT [3:0] used when the BUS Master interface issues a transfer request. bit 15 0b: Cache disabled. 1b: Cache enabled. bit 14 0b: Buffer disabled. 1b: Buffer enabled. bit 13 0b: User access 1b: Privileged access bit 12 0b: Operation code 1b: Data
11 to 9	—	All 0	R	Reserved The write value should always be 0.
8	PROT_MODE	0	R/W	This bit selects the mode of MHPROT [3:0] used when the Master interface issues a transfer request. 0b: The value of PROT_TYPE is output as MHPROT [3:0]. 1b: When a DMA transfer is performed, MHPROT [3:0] is set to 0000b if the final burst is performed, or MHPROT [3:0] is set to the PROT_TYPE value if another burst transfer is performed.
7, 6	—	All 0	R	Reserved The write value should always be 0.
5, 4	ALIGN_ADDRESSES	All 0	R/W	This field sets the address boundary used when the BUS Master interface issues a burst transfer. 00b: A burst transfer is issued so that not to exceed 1-Kbyte boundary. 01b: A burst transfer is issued so that not to exceed 64-byte boundary. 10b: A burst transfer is issued so that not to exceed 32-byte boundary. (The maximum burst length is INCR8. This is because, if INCR16 is used, 32-byte boundary is exceeded.) 11b: A burst transfer is issued so that not to exceed 16 byte boundary. (The maximum burst length is INCR4. This is because, if the length is at least INCR8, 16-byte boundary is exceeded.)
3,2	—	All 0	R	Reserved The write value should always be 0.

Bit	Bit Name	Initial Value	R/W	Description
1, 0	MAX_BURST_LEN	All 0	R/W	This field selects the maximum burst length used when the BUS Master interface issues a transfer request. 00b: INCR16 01b: INCR8 10b: INCR4 11b: SINGLE

(4) USBCTR Register

Abbreviated name of register: USBCTR

Bit	31	30	29	28	27	26	25	24	23	22	21	20	19	18	17	16
	—	—	—	—	—	—	—	—	—	—	—	—	—	—	—	—
Initial Value	0	0	0	0	0	0	0	0	0	0	0	0	0	0	0	0
R/W	R	R	R	R	R	R	R	R	R	R	R	R	R	R	R	R
Bit	15	14	13	12	11	10	9	8	7	6	5	4	3	2	1	0
	—	—	—	—	—	—	—	—	—	—	—	—	—	DIRPD	PLL_RST	USBH_RST
Initial Value	0	0	0	0	0	0	0	0	0	0	0	0	0	0	1	0
R/W	R	R	R	R	R	R	R	R	R	R	R	R	R	R/W	R/W	W

Bit	Bit Name	Initial Value	R/W	Description
31 to 3	—	All 0	R	Reserved The write value should always be 0.
2	DIRPD	0	R/W	USBPHY Standby Mode Control 0b: USBPHY normal operating mode 1b: USBPHY standby mode <i>Note:</i> When the USB module is not in use, setting this bit to 1 reduces power consumption by the USBPHY module. Only set it to 1 when the USB module is not in use. In transitions from USBPHY standby mode to USBPHY normal operating mode, assert the reset signal for the USBPHY module for at least 1 μ s before the transition.
1	PLL_RST	1	R/W	This bit controls resetting of the USBPHY module. 0b: The USBPHY reset is released. 1b: The USBPHY module is reset.
0	USBH_RST	0	W	Software reset to this module. Setting this bit to 1b resets this module entirely. This bit is always read as 0b. <i>Note:</i> Set this bit only when the BUS Master interface of this module is not running. Access to this module becomes valid 10 CLK (internal bus clock [P1 ϕ]) after this bit is written. 0b: Nothing occurs. 1b: Reset is issued to this module.

(5) Register Enable/Clock Gating Control Register

Abbreviated name of register: REGEN_CG_CTRL

Bit	31	30	29	28	27	26	25	24	23	22	21	20	19	18	17	16
	NONUSE_CLK_MSK	—	HOST_CLK_MSK	PERI_CLK_MSK	—	—	—	—	—	—	—	—	—	—	—	—
Initial Value	0	0	0	0	0	0	0	0	0	0	0	0	0	0	0	0
R/W	R/W	R	R/W	R/W	R	R	R	R	R	R	R	R	R	R	R	R
Bit	15	14	13	12	11	10	9	8	7	6	5	4	3	2	1	0
	—	—	—	—	—	—	—	—	—	—	—	—	—	—	—	—
Initial Value	0	0	0	0	0	0	0	0	0	0	0	0	0	0	0	0
R/W	R	R	R	R	R	R	R	R	R	R	R	R	R	R	R	R

Bit	Bit Name	Initial Value	R/W	Description
31	NONUSE_CLK_MSK	0	R/W	This bit is used to mask the clock for the unused host or peripheral controller, depending on the setting value of the OTG_PERI bit of the COMMCTRL register. 0b: Do not mask the clock. 1b: Mask the clock. For details, see Section 32A.3.1.2, Specifications of NONUSE_CLK_MSK operation.
30	—	0	R	Reserved The write value should always be 0.
29	HOST_CLK_MSK	0	R/W	This bit is used to forcibly mask clock supply to the host controller. 0b: Do not mask the clock supply. 1b: Mask the clock supply. For details, see Section 32A.3.1.3, Specifications of PERI_CLK_MSK and HOST_CLK_MSK operations.
28	PERI_CLK_MSK	0	R/W	This bit is used to forcibly mask the clock supply to the peripheral controller. 0b: Do not mask the clock supply. 1b: Mask the clock supply. For details, see Section 32A.3.1.3, Specifications of PERI_CLK_MSK and HOST_CLK_MSK operations.
27 to 24	—	All 0	R	Reserved The write value should always be 0.
23 to 0	—	All 0	R	Reserved The write value should always be 0.

(6) Suspend Control Register

Abbreviated name of register: SPD_CTRL

Bit	31	30	29	28	27	26	25	24	23	22	21	20	19	18	17	16
	SUSPENDM_ENABLE	SLEEPM_ENABLE	—	—	—	—	—	—	WKCNT_ENABLE	—	—	—	—	—	—	—
Initial Value	0	0	0	0	0	0	0	0	0	0	0	0	0	0	0	0
R/W	R/W	R/W	R	R	R	R	R	R	R/W	R/W	R	R	R	R	R	R
Bit	15	14	13	12	11	10	9	8	7	6	5	4	3	2	1	0
	—	—	—	—	—	—	—	—	—	—	—	—	—	—	—	GLOBAL_SUSPENDM_P1
Initial Value	0	0	0	0	0	0	0	0	0	0	0	0	0	0	0	0
R/W	R	R	R	R	R	R	R	R	R	R	R	R	R	R	R	R/W

Bit	Bit Name	Initial Value	R/W	Description
31	SUSPENDM_ENABLE	0	R/W	<p>The setting of this bit is valid only in the Host mode (when the OTG_PERI bit of the COMMCTRL register is 0b).</p> <p>This bit is used to place USBPHY into the suspend status (the state in which PHY built-in PLL is stopped) when this module is changed to the USB Suspend mode. If this bit is set to 1b, the Suspend related bits of the OHCI/EHCI Operational registers below are set. If this module is changed to the USB Suspend mode, USBPHY is placed into the suspend status.</p> <p>[This function is valid for the following OHCI/EHCI Operational registers]</p> <p style="padding-left: 20px;">EHCI: bit [7] (Suspend bit) of the PORTSC1 register</p> <p style="padding-left: 20px;">OHCI: bit [2] (PSS bit) of the HcRhPortStatus register</p> <p style="padding-left: 20px;">OHCI: bit [7:6] (HCFS field) of the HcControl register</p>
30	SLEEPM_ENABLE	0	R/W	<p>The setting of this bit is valid only in the Host mode (when the OTG_PERI bit of the COMMCTRL register is 0b).</p> <p>This bit is used to place USBPHY into the sleep status when the LPM function is used to change to the L1 Suspend mode. (In the sleep status, the PHY built-in PLL is running, but the 60MHz clock from USBPHY is gated.)</p> <p>This bit is valid when "Suspend using L1" of the POTSC register is 1b. If this bit is set to 1b, an L1 transition request is issued to the device. If the request is accepted, USBPHY is placed into the sleep status after the following EHCI register bit is set to 1b.</p> <p>[This function is valid for the following OHCI/EHCI Operational register]</p> <p style="padding-left: 20px;">EHCI: bit [7] (Suspend bit) of the PORTSC1 register</p>
29 to 24	—	All 0	R	<p>Reserved</p> <p>The write value should always be 0.</p>
23	WKCNT_ENABLE	0	R/W	<p>The setting of this bit is valid only in the Host mode (the OTG_PERI bit of the COMMCTRL register is 0b).</p> <p>If this bit is set to 1b, when a device disconnect occurs while USBPHY is in the suspend or sleep status, the suspend or sleep status is released.</p> <p>This bit is valid only when the SUSPENDM_ENABLE bit (bit 31) or SLEEPM_ENABLE bit (bit 30) is 1b.</p> <p><i>Note:</i> To set 1b to the SUSPENDM_ENABLE bit (bit 31) or SLEEPM_ENABLE bit (bit 30), as the general rule, set this bit to 1b.</p> <p>If, in the above case, this bit is not set to 1b, the suspend or sleep status cannot be released even if a device disconnect occurs.</p>
22 to 1	—	All 0	R	<p>Reserved</p> <p>The write value should always be 0.</p>

Bit	Bit Name	Initial Value	R/W	Description
0	GLOBAL_SUSPENDM_P1	0	R/W	<p>The setting of this bit is valid regardless of the value of the OTG_PERI bit of the COMMCTRL register.</p> <p>This bit is used to forcibly place USBPHY into the suspend status (in which the PHY built-in PLL is stopped).</p> <p>If this bit is set to 1b, USBPHY is placed into the suspend status, regardless of the operating status and port status of the host controller.</p> <p><i>Note:</i></p> <ul style="list-style-type: none"> – Do not set this bit to 1b during data transfer. We recommend that you set this bit to 1b after “stopping the EHCI/OHCI list processing” and “placing the port in the Disable status”. – If the SUSPENDM_ENABLE bit (bit 31) is 1b, do not set this bit to 1b.

(7) Suspend/Resume Timer Setting Register

Abbreviated name of register: SPD_RSM_TIMSET

Bit	31	30	29	28	27	26	25	24	23	22	21	20	19	18	17	16
	TIMER_CONNECT[15:8]								TIMER_CONNECT[7:0]							
Initial Value	0	0	0	0	0	0	0	1	1	1	1	1	0	1	0	0
R/W	R/W	R/W	R/W	R/W	R/W	R/W	R/W	R/W	R/W	R/W	R/W	R/W	R/W	R/W	R/W	R/W
Bit	15	14	13	12	11	10	9	8	7	6	5	4	3	2	1	0
	TIMER_RESUME[15:8]								TIMER_RESUME[7:0]							
Initial Value	0	0	0	0	0	0	1	1	1	1	1	0	1	0	0	0
R/W	R/W	R/W	R/W	R/W	R/W	R/W	R/W	R/W	R/W	R/W	R/W	R/W	R/W	R/W	R/W	R/W

Bit	Bit Name	Initial Value	R/W	Description
31 to 16	TIMER_CONNECT[15:0]	H'01F4	R/W	<p>This field indicates the timer value used by USBPHY to detect Device Connect/Disconnect of the device in the suspend status (in which the PHY built-in PLL is stopped) when the SUSPENDM_ENABLE bit of the SPD_CTRL register is set to 1b.</p> <p>When USBPHY is in suspend status, whether Connect/Disconnect occurs is judged by the internal bus clock (P1ϕ).</p> <p>According to the internal bus clock (P1ϕ) frequency, specify the setting so that this timer value becomes at least 2.5 μs.</p> <p>1 bit = 1 cycle (μs)</p> <p>(Setting guideline)</p> <p>For 100 MHz: At least H'FA</p>
15 to 0	TIMER_RESUME[15:0]	H'03E8	R/W	<p>This field indicates the timer value used by USBPHY to detect RemoteWakeup signal from the device in suspend status (in which the PHY built-in PLL is stopped) when the SUSPENDM_ENABLE bit of the SPD_CTRL register is set to 1b.</p> <p>When USBPHY is in suspend status, whether the RemoteWakeup signal or not is judged by the internal bus clock (P1ϕ).</p> <p>According to the internal bus clock (P1ϕ) frequency, specify the setting so that this timer value becomes at least 5 μs.</p> <p>1 bit = 1 cycle (μs)</p> <p>(Setting guideline)</p> <p>For 100 MHz: At least H'1F4</p>

(8) Overcurrent Detection/Sleep Timer Setting Register

Abbreviated name of register: OC_SLP_TIMSET

Bit	31	30	29	28	27	26	25	24	23	22	21	20	19	18	17	16
	—	—	—	TIMER_SLEEP[8:4]				TIMER_SLEEP[3:0]				TIMER_OC[19:16]				
Initial Value	0	0	0	0	1	1	0	0	1	0	0	0	0	0	1	1
R/W	R	R	R	R/W	R/W	R/W	R/W	R/W	R/W	R/W	R/W	R/W	R/W	R/W	R/W	R/W
Bit	15	14	13	12	11	10	9	8	7	6	5	4	3	2	1	0
	TIMER_OC[15:8]								TIMER_OC[7:0]							
Initial Value	0	0	0	0	1	1	0	1	0	1	0	0	0	0	0	0
R/W	R/W	R/W	R/W	R/W	R/W	R/W	R/W	R/W	R/W	R/W	R/W	R/W	R/W	R/W	R/W	R/W

Bit	Bit Name	Initial Value	R/W	Description
31 to 29	—	All 0	R	Reserved The write value should always be 0.
28 to 20	TIMER_SLEEP[8:0]	H'0C8	R/W	This field indicates the timer value used by USBPHY when the SLEEPM_ENABLE bit of the SPD_CTRL register is set to 1b. This timer value is used to measure the time for detecting RemoteWakeup reception and Resume-K drive time during sleep status (in which the PHY built-in PLL is running, but 60MHz clock from the USBPHY is gated). When USBPHY is in sleep status, whether the RemoteWakeup signal or not is judged by the internal bus clock (P1 ϕ). According to the internal bus clock (P1 ϕ) frequency, specify the setting so that this timer value becomes 1 μ s. 1 bit = 1 cycle (μ s) (Setting guideline) For 100 MHz: H'064
19 to 0	TIMER_OC[19:0]	H'30D40	R/W	This field indicates the timer value used for overcurrent detection. If the overcurrent input (OVRCUR) set in this field is continuously asserted (0b) for the duration set in this register, this module determines that overcurrent occurred. According to the internal bus clock (P1 ϕ) frequency, specify the setting so that this timer value becomes at least 1 ms. 1 bit is 1 cycle (μ s). (Setting guideline) For 100 MHz and 1 ms: At least H'1_86A0

(9) SBRN_FLADJ_PORTWAKECAP Register

Abbreviated name of register: SBRN_FLADJ_PW

Bit	31	30	29	28	27	26	25	24	23	22	21	20	19	18	17	16
	PORTWAKECAP[15:8]								PORTWAKECAP[7:0]							
Initial Value	0	0	0	0	0	0	0	0	0	0	0	0	0	0	1	1
R/W	R/W	R/W	R/W	R/W	R/W	R/W	R/W	R/W	R/W	R/W	R/W	R/W	R/W	R/W	R/W	R/W
Bit	15	14	13	12	11	10	9	8	7	6	5	4	3	2	1	0
	FLADJ[7:0]							SBRN[7:0]								
Initial Value	0	0	1	0	0	0	0	0	0	0	1	0	0	0	0	0
R/W	R	R	R/W	R/W	R/W	R/W	R/W	R/W	R	R	R	R	R	R	R	R

Bit	Bit Name	Initial Value	R/W	Description
31 to 16	PORTWAKECAP[15:0]	H'0003	R/W	This field is used to mask the ports (of the connected device) that are used for Wakeup event. Operation on this field has no effect on the operation of the HOST module.
15 to 8	FLADJ[7:0]	H'20	R, R/W	This field adjusts the length of one micro frame by 16HS bit time unit. The initial value indicates H'20 (60000d HS bit time).
7 to 0	SBRN[7:0]	H'20	R	This field indicates the Serial Bus Release Number. The fixed value "H'20" is indicated.

(10) PORT_LPM_CTR1 Register

Abbreviated name of register: PORT_LPM_CTRL1

Bit	31	30	29	28	27	26	25	24	23	22	21	20	19	18	17	16
	—	—	—	—	—	—	—	—	—	—	—	—	—	—	—	—
Initial Value	0	0	0	0	0	0	0	0	0	0	0	0	0	0	0	0
R/W	R	R	R	R	R	R	R	R	R	R	R	R	R	R	R	R
Bit	15	14	13	12	11	10	9	8	7	6	5	4	3	2	1	0
	—	—	—	—	—	—	—	—	NYET_RETRY_CNT_P1[3:0]				REMOT EWAKE _EN_P1	SLEEP INT_EN _P1	RETRY ENABL E_NYE T_P1	HIRD_S EL_P1
Initial Value	0	0	0	0	0	0	0	0	0	0	0	0	0	0	0	0
R/W	R	R	R	R	R	R	R	R	R/W	R/W	R/W	R/W	R/W	R/W	R/W	R/W

Bit	Bit Name	Initial Value	R/W	Description
31 to 8	—	All 0	R	Reserved The write value should always be 0.
7 to 4	NYET_RETR Y_CNT_P1[3: 0]	All 0	R/W	This field sets the number of retries that are allowed when the response from the device in the LPM transaction was NYET. The setting value of this bit is valid if the RETRY_ENABLE_NYET_P1 bit (bit 1) is 1b. 0000b: No retry. 0001b to 1111b: Retries the set number of times. (MAX: 15 retries)
3	REMOT EWAKE _EN_P1	0	R/W	This bit is used to indicate the value of the RemoteWakeup bit of the LPM Token. 0b: RemoteWakeup is supported. 1b: RemoteWakeup is not supported.
2	SLEEP_INT_ EN_P1	0	R/W	This bit is used to enable an interrupt to occur when a status other than ACK is received in the LPM transaction. The Per-Port Change interrupt can occur. 0b: No interrupt occurs. 1b: An interrupt occurs.
1	RETRY_ENA BLE_NYET_P 1	0	R/W	This bit is used to set the behavior of the host controller when a response from the device is NYET in an LPM transaction. 0b: No retry. 1b: Retries are made.

Bit	Bit Name	Initial Value	R/W	Description																																																						
0	HIRD_SEL_P1	0	R/W	This bit sets the time for K drive for when recovered from the Sleep state. Based on the setting values of this bit and EHCI USBCMD Register bit [27:24], the K drive time is determined as follows.																																																						
<table border="1"> <thead> <tr> <th>USBCMD Register</th> <th colspan="2">HIRD_SEL_P1 (Setting value of this bit)</th> </tr> <tr> <th>bit [27:24]</th> <th>0b</th> <th>1</th> </tr> </thead> <tbody> <tr><td>0000b</td><td>75 μs</td><td>50 μs</td></tr> <tr><td>0001b</td><td>100 μs</td><td>125 μs</td></tr> <tr><td>0010b</td><td>150 μs</td><td>200 μs</td></tr> <tr><td>0011b</td><td>250 μs</td><td>275 μs</td></tr> <tr><td>0100b</td><td>350 μs</td><td>350 μs</td></tr> <tr><td>0101b</td><td>450 μs</td><td>425 μs</td></tr> <tr><td>0110b</td><td>950 μs</td><td>500 μs</td></tr> <tr><td>0111b</td><td>1950 μs</td><td>575 μs</td></tr> <tr><td>1000b</td><td>2950 μs</td><td>650 μs</td></tr> <tr><td>1001b</td><td>3950 μs</td><td>725 μs</td></tr> <tr><td>1010b</td><td>4950 μs</td><td>800 μs</td></tr> <tr><td>1011b</td><td>5950 μs</td><td>875 μs</td></tr> <tr><td>1100b</td><td>6950 μs</td><td>950 μs</td></tr> <tr><td>1101b</td><td>7950 μs</td><td>1025 μs</td></tr> <tr><td>1110b</td><td>8950 μs</td><td>1100 μs</td></tr> <tr><td>1111b</td><td>9950 μs</td><td>1175 μs</td></tr> </tbody> </table>					USBCMD Register	HIRD_SEL_P1 (Setting value of this bit)		bit [27:24]	0b	1	0000b	75 μ s	50 μ s	0001b	100 μ s	125 μ s	0010b	150 μ s	200 μ s	0011b	250 μ s	275 μ s	0100b	350 μ s	350 μ s	0101b	450 μ s	425 μ s	0110b	950 μ s	500 μ s	0111b	1950 μ s	575 μ s	1000b	2950 μ s	650 μ s	1001b	3950 μ s	725 μ s	1010b	4950 μ s	800 μ s	1011b	5950 μ s	875 μ s	1100b	6950 μ s	950 μ s	1101b	7950 μ s	1025 μ s	1110b	8950 μ s	1100 μ s	1111b	9950 μ s	1175 μ s
USBCMD Register	HIRD_SEL_P1 (Setting value of this bit)																																																									
bit [27:24]	0b	1																																																								
0000b	75 μ s	50 μ s																																																								
0001b	100 μ s	125 μ s																																																								
0010b	150 μ s	200 μ s																																																								
0011b	250 μ s	275 μ s																																																								
0100b	350 μ s	350 μ s																																																								
0101b	450 μ s	425 μ s																																																								
0110b	950 μ s	500 μ s																																																								
0111b	1950 μ s	575 μ s																																																								
1000b	2950 μ s	650 μ s																																																								
1001b	3950 μ s	725 μ s																																																								
1010b	4950 μ s	800 μ s																																																								
1011b	5950 μ s	875 μ s																																																								
1100b	6950 μ s	950 μ s																																																								
1101b	7950 μ s	1025 μ s																																																								
1110b	8950 μ s	1100 μ s																																																								
1111b	9950 μ s	1175 μ s																																																								

32A.2.4.5 UCOM Register

(1) Common Control Register

Abbreviated name of register: COMMCTRL

Bit	31	30	29	28	27	26	25	24	23	22	21	20	19	18	17	16
	OTG_P ERI	—	—	—	—	—	—	—	—	—	—	—	—	—	—	—
Initial Value	1	0	0	0	0	0	0	0	0	0	0	0	0	0	0	0
R/W	R/W	R	R	R	R	R	R	R	R	R	R	R	R	R	R	R
Bit	15	14	13	12	11	10	9	8	7	6	5	4	3	2	1	0
	—	—	—	—	—	—	—	—	—	—	—	—	—	—	—	—
Initial Value	0	0	0	0	0	0	0	0	0	0	0	0	0	0	0	0
R/W	R	R	R	R	R	R	R	R	R	R	R	R	R	R	R	R

Bit	Bit Name	Initial Value	R/W	Description
31	OTG_PERI	1	R/W	This bit specifies whether this module is set to the host mode or function mode. 0b: Host mode 1b: Function mode (Only CH0 can be set)
30 to 0	—	All 0	R	Reserved When read, the initial value is read. When writing, be sure to write the initial value.

(2) OTG-BC Interrupt Status Register

Abbreviated name of register: OBINTSTA

Bit	31	30	29	28	27	26	25	24	23	22	21	20	19	18	17	16
	—	—	—	—	—	—	—	—	—	—	—	—	—	—	DPMON CHG_STA	DMMON CHG_STA
Initial Value	0	0	0	0	0	0	0	0	0	0	0	0	0	0	0	0
R/W	R	R	R	R	R	R	R	R	R	R	R	R	R	R	R/W(1)	R/W(1)
Bit	15	14	13	12	11	10	9	8	7	6	5	4	3	2	1	0
	—	—	—	—	—	—	—	—	—	CHGDE TCHG1 _STA	—	PDE TCHG1 _STA	—	—	OCINT _STA	IDCHG _STA
Initial Value	0	0	0	0	0	0	0	0	0	0	0	0	0	0	0	1
R/W	R	R	R	R	R	R	R	R	R	R/W(1)	R	R/W(1)	R	R	R/W(1)	R/W(1)

Bit	Bit Name	Initial Value	R/W	Description
31 to 18	—	All 0	R	Reserved The write value should always be 0.
17	DPMONCHG_STA	0	R/W (1)	This bit is set if the DPMON bit of the LINECTRL1 register has changed. 0b: The DPMON bit of the LINECTRL1 register has not changed. 1b: The DPMON bit of the LINECTRL1 register has changed.
16	DMMONCHG_STA	0	R/W (1)	This bit is set if the DMMON bit of the LINECTRL1 register has changed. 0b: The DMMON bit of the LINECTRL1 register has not changed. 1b: The DMMON bit of the LINECTRL1 register has changed.
15 to 7	—	All 0	R	Reserved The write value should always be 0.
6	CHGDETCHG1_STA	0	R/W (1)	This bit is set if the CHGDETSTS bit of the BCCTRL1 register has changed from 0b to 1b. 0b: The CHGDETSTS bit of the BCCTRL1 register has not changed from 0b to 1b 1b: The CHGDETSTS bit of the BCCTRL1 register has changed from 0b to 1b.
5	—	0	R	Reserved The write value should always be 0.
4	PDETCCHG1_STA	0	R/W (1)	This bit is set if the PDETCSTS bit of the BCCTRL1 register has changed from 0b to 1b. 0b: The PDETCSTS bit of the BCCTRL1 register has not changed from 0b to 1b. 1b: The PDETCSTS bit of the BCCTRL1 register has changed from 0b to 1b.
3	—	0	R	Reserved When read, the initial value is read. When writing, be sure to write the initial value. Operation is not guaranteed if a value other than the initial value is written.
2	—	0	R	Reserved When read, the initial value is read. When writing, be sure to write the initial value. Operation is not guaranteed if a value other than the initial value is written.
1	OCINT_STA	0	R/W (1)	This bit is set if the OVRCUR pin is asserted. 0b: The OVRCUR pin is not asserted (and remains 1b). 1b: The OVRCUR pin is asserted (and became 0b).
0	IDCHG_STA	1	R/W (1)	This bit is set if the input value from the OTG_ID pin has changed. 0b: There is no change in the OTG_ID pin. 1b: There is a change in the OTG_ID pin.

Note: The initial value is 1. Before using this bit, clear the status.

(3) OTG-BC Interrupt Enable Register

Abbreviated name of register: OBINTEN

Bit	31	30	29	28	27	26	25	24	23	22	21	20	19	18	17	16
	—	—	—	—	—	—	—	—	—	—	—	—	—	—	DPMONCHG_EN	DMMONCHG_EN
Initial Value	0	0	0	0	0	0	0	0	0	0	0	0	0	0	0	0
R/W	R	R	R	R	R	R	R	R	R	R	R	R	R	R	R/W	R/W
Bit	15	14	13	12	11	10	9	8	7	6	5	4	3	2	1	0
	—	—	—	—	—	—	—	—	—	CHGDETCHG1_EN	—	PDDETCHG1_EN	—	—	OCINT_EN	IDCHG_EN
Initial Value	0	0	0	0	0	0	0	0	0	0	0	0	0	0	0	0
R/W	R	R	R	R	R	R	R	R	R	R/W	R	R/W	R	R	R/W	R/W

Bit	Bit Name	Initial Value	R/W	Description
31 to 18	—	All 0	R	Reserved The write value should always be 0.
17	DPMONCHG_EN	0	R/W	DPMONCHG_STA bit interrupt enable 0b: Interrupt via the DPMONCHG_STA bit is disabled. 1b: Interrupt via the DPMONCHG_STA bit is enabled.
16	DMMONCHG_EN	0	R/W	DMMONCHG_STA bit interrupt enable 0b: Interrupt via the DMMONCHG_STA bit is disabled. 1b: Interrupt via the DMMONCHG_STA bit is enabled.
15 to 7	—	All 0	R	Reserved The write value should always be 0.
6	CHGDETCHG1_EN	0	R/W	CHGDETCHG1_STA bit interrupt enable 0b: Interrupt via the CHGDETCHG1_STA bit is disabled. 1b: Interrupt via the CHGDETCHG1_STA bit is enabled.
5	—	0	R	Reserved The write value should always be 0.
4	PDDETCHG1_EN	0	R/W	PDDETCHG1_STA bit interrupt enable 0b: Interrupt via the PDDETCHG1_STA bit is disabled. 1b: Interrupt via the PDDETCHG1_STA bit is enabled.
3	—	0	R	Reserved When read, the initial value is read. When writing, be sure to write the initial value. Operation is not guaranteed if a value other than the initial value is written.
2	—	0	R	Reserved When read, the initial value is read. When writing, be sure to write the initial value. Operation is not guaranteed if a value other than the initial value is written.
1	OCINT_EN	0	R/W	OCINT_STA bit interrupt enable 0b: Interrupt via the OCINT_STA bit is disabled. 1b: Interrupt via the OCINT_STA bit is enabled.
0	IDCHG_EN	0	R/W	IDCHG_STA bit interrupt enable 0b: Interrupt via the IDCHG_STA bit is disabled. 1b: Interrupt via the IDCHG_STA bit is enabled.

(4) VBUS Control Register

Abbreviated name of register: VBCTRL

Bit	31	30	29	28	27	26	25	24	23	22	21	20	19	18	17	16
	—	—	—	—	—	—	—	—	—	—	—	—	—	—	—	—
Initial Value	0	0	0	0	0	0	0	0	0	0	0	0	0	0	0	1
R/W	R	R	R	R	R	R	R	R	R	R	R	R	R	R	R	R
Bit	15	14	13	12	11	10	9	8	7	6	5	4	3	2	1	0
	—	—	—	—	—	—	—	—	—	—	—	VGPUO	—	—	—	VBOUT
Initial Value	0	0	0	0	0	0	0	0	0	0	0	0	0	0	0	0
R/W	R	R	R	R	R	R	R	R	R	R	R	R/W	R	R	R	R/W

Bit	Bit Name	Initial Value	R/W	Description
31, 30	—	All 0	R	Reserved The write value should always be 0.
29	—	0	R	Reserved When read, the initial value is read. When writing, be sure to write the initial value.
28 to 22	—	All 0	R	Reserved When read, the initial value is read. When writing, be sure to write the initial value.
21	—	0	R	Reserved When read, the initial value is read. When writing, be sure to write the initial value.
20 to 17	—	All 0	R	Reserved The write value should always be 0.
16	—	1	R	Reserved The write value should always be 1.
15 to 5	—	All 0	R	Reserved When read, the initial value is read. When writing, be sure to write the initial value.
4	VGPUO	0	R/W	The level corresponding to the inverse of this bit (in terms of positive logic) is output from the OTG_EXICEN pin. This bit is used, for example, for control of the external power IC.
3 to 1	—	All 0	R	Reserved The write value should always be 0.
0	VBOUT	0	R/W	This bit is one of the VBUS control bits. This bit is used to assert VBUS by controlling the external power IC. 0b: VBUS output disable 1b: VBUS output enable If overcurrent occurs, this bit is automatically cleared to 0.

(5) Line Control Port 1 Register

Abbreviated name of register: LINECTRL1

Bit	31	30	29	28	27	26	25	24	23	22	21	20	19	18	17	16
	—	—	—	—	—	—	—	—	—	—	DPRPU_EN	DP_RPU	DPRPD_EN	DP_RPD	DMRPD_EN	DM_RPD
Initial Value	0	0	0	0	0	0	0	0	0	0	0	0	0	0	0	0
R/W	R	R	R	R	R	R	R	R	R	R	R/W	R/W	R/W	R/W	R/W	R/W
Bit	15	14	13	12	11	10	9	8	7	6	5	4	3	2	1	0
	—	—	—	—	—	—	—	—	—	—	—	—	DPMON	DMMON	—	IDMON
Initial Value	0	0	0	0	0	0	0	0	0	0	0	0	0	0	0	0
R/W	R	R	R	R	R	R	R	R	R	R	R	R	R	R	R	R

Bit	Bit Name	Initial Value	R/W	Description
31 to 26	—	All 0	R	Reserved
25, 24	—	All 0	R	Reserved When read, the initial value is read. When writing, be sure to write the initial value. Operation is not guaranteed if a value other than the initial value is written.
23, 22	—	All 0	R	Reserved
21	DPRPU_EN	0	R/W	This bit enables the DP_RPU (bit 20) setting for pullup control of D+ in port 1. 0: DP_RPU (bit 20) setting for pullup control of D+ in port 1 is disabled. 1: DP_RPU (bit 20) setting for pullup control of D+ in port 1 is enabled.
20	DP_RPU	0	R/W	This bit controls pullup of D+ in port 1. This control is enabled only when DPRPU_EN (bit 21) = 1. Note that if this bit is cleared to 0 when DPRPU_EN (bit 21) = 1, D+ is in the floating state while no device drives the USB bus. Note also that setting DPRPD_EN (bit 19) and DP_RPD (bit 18) to enabled is prohibited while this bit is set to enabled - that is, enabling both pullup and pulldown of D+ together is prohibited. 0: Pullup of D+ in port 1 is disabled. 1: Pullup of D+ in port 1 is enabled.
19	DPRPD_EN	0	R/W	This bit enables DP_RPD (bit 18) to control USB bus (DP) 15 kΩ Pulldown resistor. 0b: Control of DP-side 15 kΩ Pulldown resistor by DP_RPD (bit 18) is disabled. 1b: Control of DP-side 15 kΩ Pulldown resistor by DP_RPD (bit 18) is enabled.
18	DP_RPD	0	R/W	This bit controls USB bus (DP) 15 kΩ Pulldown resistor when DPRPD_EN (bit 19) = 1b. 0b: DP-side 15 kΩ Pulldown resistor is OFF. 1b: DP-side 15 kΩ Pulldown resistor is ON.
17	DMRPD_EN	0	R/W	This bit enables DM_RPD (bit 16) to control USB bus (DM) 15 kΩ Pulldown resistor. 0b: Control of DM-side 15 kΩ Pulldown resistor by DM_RPD (bit 16) is disabled. 1b: Control of DM-side 15 kΩ Pulldown resistor by DM_RPD (bit 16) is enabled.
16	DM_RPD	0	R/W	This bit controls USB bus (DM) 15 kΩ Pulldown resistor when DMRPD_EN (bit 17) = 1b. 0b: DM-side 15 kΩ Pulldown resistor is OFF. 1b: DM-side 15 kΩ Pulldown register is ON.
15 to 4	—	All 0	R	Reserved The write value should always be 0.
3	DPMON	0	R	This bit indicates the value of USB bus DP.
2	DMMON	0	R	This bit indicates the value of USB bus DM.
1	—	0	R	Reserved The write value should always be 0.

Bit	Bit Name	Initial Value	R/W	Description
0	IDMON	0	R	This bit indicates the value of the OTG_ID pin.

(6) BC Control Port 1 Register

Abbreviated name of register: BCCTRL1

Bit	31	30	29	28	27	26	25	24	23	22	21	20	19	18	17	16
	—	—	—	—	—	—	—	—	—	—	—	—	—	—	—	—
Initial Value	0	0	0	0	0	0	1	1	0	0	0	0	0	0	0	0
R/W	R	R	R	R	R	R	R	R	R	R	R	R	R	R	R	R
Bit	15	14	13	12	11	10	9	8	7	6	5	4	3	2	1	0
	—	—	—	—	—	—	PDDET STS	CHGDE TSTS	—	—	DCPMO DE	VDMSR CE	IDPSIN KE	VDPSR CE	IDMSIN KE	IDPSRC E
Initial Value	0	0	0	0	0	0	0	0	0	0	0	0	0	0	0	0
R/W	R	R	R	R	R	R	R	R	R	R	R/W	R/W	R/W	R/W	R/W	R/W

Bit	Bit Name	Initial Value	R/W	Description
31 to 10	—	H'00_C00 0	R	Reserved When read, the initial value is read. When writing, be sure to write the initial value.
9	PDDETSTS	0	R	This bit indicates the USBPHY Portable Device Detect signal state.
8	CHGDETSTS	0	R	This bit indicates the USBPHY Charging Downstream Port Detect signal state.
7, 6	—	All 0	R	Reserved The write value should always be 0.
5	DCPMODE	0	R	If USBPHY is used as DCP (Dedicated Charging Port), this bit is set to 1b.
4	VDMSRCE	0	R/W	This bit controls the USBPHY built-in VDM_SRC circuit. If this bit is set to 1b, VDM_SRC goes ON, and the DM pin is driven.
3	IDPSINKE	0	R/W	This bit controls the USBPHY built-in Portable Device Detect circuit. If this bit is set to 1b, Portable Device detection is enabled.
2	VDPSRCE	0	R/W	This bit controls the USBPHY built-in VDP_SRC circuit. If this bit is set to 1b, VDP_SRC goes ON, and the DP pin is driven.
1	IDMSINKE	0	R/W	This bit controls the USBPHY built-in Charging Downstream Port Detect circuit. If this bit is set to 1b, Charging Downstream Port detection is enabled.
0	IDPSRCE	0	R/W	This bit controls the USBPHY built-in IDP_SRC circuit. If this bit is set to 1b, IDP_SRC goes ON, and the DP pin is driven.

32A.3 Clock Signals

32A.3.1 Clock Gating Specifications

32A.3.1.1 Overview of clock gating

Because this module has a feature of switching the host controller and peripheral controller, clock supply to the unused controller might not be necessary.

Therefore, three clock gating control bits are allocated in the Register Enable/Clock Gating Control Register for the purpose of reducing power consumption by implementing clock gating for the “circuits that do not require clock supply temporarily.”

The clock gating control bits can be controlled to gate the clock that is supplied to the host controller or the peripheral controller.

[Target Register]

Register Enable/Clock Gating Control Register (offset:H'304)

[Functional specification]

bit	Symbol	Functional specification
31	NONUSE_CLK_MSK	Gating clocks for unused host controller or peripheral controller.
29	HOST_CLK_MSK	Gating clocks for host controller.
28	PERI_CLK_MSK	Gating clocks for peripheral controller.

32A.3.1.2 Specifications of NONUSE_CLK_MSK operation

This function automatically gates the clock to the unused host controller or the unused peripheral controller.

This function is enabled if the NONUSE_CLK_MSK bit (bit 31) is set to 1b.

If it is no problem whether the clock supply to the unselected function is stopped, use this function.

The following table shows the operating specifications of this function, based on the setting of the OTG_PERI bit (bit 31) of the Common Control Register (offset: H'800).

Clock Gating Register Setting			Host/Peripheral Switching Setting	Gating Target	
			Register	Host Controller	Function Controller
NONUSE_CLK_MSK	HOST_CLK_MSK	PERI_CLK_MSK	OTG_PERI		
1	0	0	0		✓
			1	✓	

[Note on using the NONUSE_CLK_MSK bit]

If the NONUSE_CLK_MSK bit is used, as the general rule, set the HOST_CLK_MSK/PERI_CLK_MSK bit to 0b.

If the HOST_CLK_MSK/PERI_CLK_MSK bit is 1b, the effect of clock gating becomes logical OR of each bit.

32A.3.1.3 Specifications of PERI_CLK_MSK and HOST_CLK_MSK operations

This function forcibly gates the clock to the host controller and function controller.

The following table shows the operating specifications of this function.

Clock Gating Register Setting			Host/Peripheral Switching Setting	Gating Target	
NONUSE_CLK_MSK	HOST_CLK_MSK	PERI_CLK_MSK	Register	Host Controller	Function Controller
0	1	0	—	✓	
	0	1	—		✓
	1	1	0	✓	✓

Note: If the HOST_CLK_MSK/PERI_CLK_MSK bit is used, as the general rule, set the NONUSE_CLK_MSK bit to 0b.
If the NONUSE_CLK_MSK bit is set to 1b, the effect of clock gating becomes logical OR of each bit.

32A.4 Interrupt Sources

32A.4.1 Interrupt Signals

This module has the five interrupt signals listed below.

Interrupt Source Name	Interrupt Type	Pulse/Level	Active Level
U2H_INT	BUS Master interrupt signal. This signal is asserted when a bus error occurs in the BUS Master. Interrupt control is performed by the AHB Bridge Register.	Level	H
U2H_OHCI_INT	OHCI interrupt signal This signal is asserted during FS/LS transfer, when data transfer finishes or when the change of the USB bus state is detected. Interrupt control is performed by the OHCI Operational Register.	Level	H
U2H_EHCI_INT	EHCI interrupt signal. This signal is asserted during HS transfer, when data transfer finishes or when the change of the USB bus state is detected. Interrupt control is performed by the EHCI Operational Register.	Level	H
U2H_WAKEON_INT	EHCI Wakeup interrupt signal. This signal is asserted by an EHCI Wakeup event. Interrupt control is performed by the EHCI Operational Register.	Level	H
U2H_OBINT	OTG/Battery Charging interrupt signal. This signal is asserted by OTG or Battery Charging related event. Interrupt control is performed by the UCOM2 Register.	Level	H

32A.4.2 Interrupt Sources and Control

32A.4.2.1 U2H_INT assertion source and control

[Interrupt enable control by register]

Assert the interrupt enable bit in the register below. The interrupt signal is asserted when an interrupt source occurs.

AHB Bridge Register INT_ENABLE Register (offset:H'200) bit[0] (AHB_INTEN)

[Interrupt source]

A bus error (MHRESP = 1b) occurs in the AHB master.

[Clearing the interrupt]

To clear the interrupt, write 1b to the relevant bit in the register below.

AHB Bridge Register INT_STATUS Register (offset:H'204) bit[0] (AHB_INT)

32A.4.2.2 U2H_OHCI_INT assertion source and control

[Interrupt enable control by register]

Assert the interrupt enable bit in the registers below. The interrupt signal is asserted when an interrupt source occurs.

AHB Bridge Register INT_ENABLE Register (offset:H'200) bit[1] (USBH_INTAEN)

OHCI Operational Register HcInterruptEnable Register (offset:H'010) bit[31], bit[6:0]*1

Note 1. Enable the bit required as the assertion source.

[Interrupt source]

Interrupt Source	Registers That Require Interrupt Enable Setting							
	USBH_INTAEN	HcInterruptEnable						
		bit [31] MIE	bit [6] RHSCE	bit [5] FNOE	bit [3] ROE	bit [2] SFE	bit [1] WDHE	bit [0] SOE
1 Device connection is detected.	✓	✓	✓					
2 Device disconnection is detected.	✓	✓	✓					
3 Port power is OFF (excluding overcurrent detection).	✓	✓	✓					
4 Babble error is detected during a USB transfer.	✓	✓	✓					
5 Resume is complete.	✓	✓	✓					
6 Overcurrent is detected.	✓	✓	✓					
7 Bus reset is complete.	✓	✓	✓					
8 When the HcRhDescriptorB Register DR bit is 1b, OHCI becomes "USB Operational" (HCFS[1:0] bit = 10b) or "USB Suspend" (HCFS[1:0] bit = 11b).	✓	✓	✓					
9 When no device is connected (CCS bit = 0b), 1 is written to bit [0] (Clear Port Enable) of the OHCI HcRhPort Status register.	✓	✓	✓					
10 When no device is connected (CCS bit = 0b), 1 is written to bit [1] (Set Port Enable) of the OHCI HcRhPort Status register.	✓	✓	✓					
11 When no device is connected (CCS bit = 0b), 1 is written to bit [2] (Set Port Suspend) of the OHCI HcRhPort Status register.	✓	✓	✓					
12 When no device is connected (CCS bit = 0b), 1 is written to bit [3] (Clear Suspend Status) of the OHCI HcRhPort Status register.	✓	✓	✓					
13 When no device is connected (CCS bit = 0b), 1 is written to bit [4] (Set Port Reset) of the OHCI HcRhPort Status register.	✓	✓	✓					
14 When no device is connected (CCS bit = 1b), the port power is turned off.	✓	✓	✓					
15 The MSB of bit [15:0] (Frame Number) of the HcFmNumber register has changed.	✓	✓		✓				
16 RemoteWakeup signal (Resume signal) is detected from a device.	✓	✓			✓			
17 HccaFrameNumber is updated. (Almost the same meaning as SOF is sent.)	✓	✓				✓		
18 A transfer finishes (including an error), and the host module updated HccaDoneHead.	✓	✓					✓	
19 USB schedule overrun occurred for the frame.	✓	✓						✓

[Clearing the interrupt]

To clear the interrupt, write 1b to the bit corresponding to the interrupt source in the register below to clear the interrupt.

OHCI Operational Register HcInterruptStatus Register (offset:H'00C) bit[6:0]

32A.4.2.3 U2H_EHCI_INT assertion source and control

[Interrupt enable control by register]

Assert the interrupt enable bit in the registers below. The interrupt signal is asserted when an interrupt source occurs.

AHB Bridge Register INT_ENABLE Register (offset:H'200) bit[2] (USBH_INTBEN)

EHCI Operational Register USBINTR Register (offset:H'128) bit[16], bit[5:0]*¹

Note 1. Enable the bit required as the assertion source.

Also, control the relevant bit(s) in the register below as required.

EHCI Operational Register USBCMD Register (offset:H'120) bit[15], bit[6]

[Interrupt source]

Interrupt Source	Registers That Require Interrupt Enable Setting								
	USBH_INTBEN	USBCMD			USBINTR				
		bit [15]	bit [6]	bit [16]	bit [5]	bit [3]	bit [2]	bit [1]	bit [0]
	Per-Port Change Event	Doorbell	Port-1 Change Event	Async Advance	Frame List Rollover	Port Change Detect	USB ERRINT	USB INT	
[1] Device connection is detected.	✓					✓			
[2] Device disconnection is detected.	✓					✓			
[3] Overcurrent is detected.	✓					✓			
[4] RemoteWakeup signal (Resume Signal) is detected from a device.	✓								
[5] Babble status of the USB bus is detected.	✓					✓			
[6] USB transfer with "qTD IOC = 1b" normally finishes.	✓								✓
[7] Short packet is received.	✓								✓
[8] USB transfer finished with an error. (Retry transfer failed three times. A bubble error was detected. STALL was received.)	✓						✓		
[9] The QH processing normally finished while the USBCMD Register bit [6] (Interrupt on Async Advance Doorbell) is 1b.	✓		✓		✓				
[10] The FRINDEX Register FrameIndex bit returned from the maximum value to H'000 (rollover detected).	✓					✓			
[11] The Port Change Detect event (interrupt source 1 to 5) was detected.	✓	✓		✓					

[Clearing the interrupt]

To clear the interrupt, write 1b to the bit corresponding to the interrupt source in the register below to clear the interrupt.

EHCI Operational Register USBSTS Register (offset:H'124) bit[16], bit[5:0]

32A.4.2.4 U2H_WAKEON_INT assertion source and control

[Interrupt enable control by register]

Assert the interrupt enable bit in the registers below. The interrupt signal is asserted when an interrupt source occurs.

AHB Bridge Register INT_ENABLE Register (offset:H'200) bit[4] (WAKEON_INTEN)

EHCI Operational Register PORTSC[1:2] Register (offset:H'164/H'168) bit[22:20]*¹

Note 1. Enable the bit required as the assertion source.

[Interrupt source]

Interrupt Source	Registers That Require Interrupt Enable Setting			
	WAKEON_ INTEN	PORTSC		
		bit [22] WKOC_E	bit [21] WKDSCNNT_E	bit [20] WKCNNNT_E
1 Device connection is detected.	✓			✓
2 Device disconnection is detected.	✓		✓	
3 Overcurrent is detected.	✓	✓		
4 RemoteWakeup signal (Resume Signal) is detected from a device.	✓			

[Clearing the interrupt]

To clear the interrupt, write 1b to the relevant bit in the register below.

AHB Bridge Register INT_STATUS Register (offset:H'204) bit[4] (WAKEON_INT)

32A.4.2.5 U2H_OBINT assertion source and control

[Interrupt enable control by register]

Assert the interrupt enable bit in the registers below. The interrupt signal is asserted when an interrupt source occurs.

AHB Bridge Register INT_ENABLE Register (offset:H'200) bit[3] (UCOM_INTEN)

UCOM Register OTG-BC Interrupt Enable Register (offset:H'808) bit[17:16], bit[6], bit[4], bit[1:0]*¹

Note 1. Enable the bit required as the assertion source.

[Interrupt source]

Interrupt Source	Registers That Require Interrupt Enable Setting		
	UCOM_INTEN	OTG-BC Interrupt Enable	
		bit [17]	bit [16]
	DPMONCHG_EN	DMMONCHG_EN	
1 The DP pin has changed.	✓	✓	
2 The DM pin has changed.	✓		✓

Interrupt Source	Registers That Require Interrupt Enable Setting		
	UCOM_INTEN	OTG-BC Interrupt Enable	
		bit [6]	bit [4]
	CHGDETCG1_EN	PDETCG1_EN	
1 The portable device detection signal has changed.	✓		✓
2 The charging port detection signal has changed.	✓	✓	

Interrupt Source	Registers That Require Interrupt Enable Setting		
	UCOM_INTEN	OTG-BC Interrupt Enable	
		bit [1]	bit [0]
	OCINT_EN	IDCHG_EN	
1 Overcurrent is detected. (The change of the OVRCUR pin from 1 to 0b is detected.)	✓	✓	
2 The OTG_ID pin has changed.	✓		✓

[Clearing the interrupt]

To clear the interrupt, write 1b to the bit corresponding to the interrupt source in the register below to clear the interrupt.

UCOM Register OTG-BC Interrupt Status Register (offset:H'804) bit[17:16], bit[6], bit[4], bit[1:0]

32A.4.3 Timing of De-asserting Interrupt Signals

After the register access to clear an interrupt source, it may take time to begin clearing the interrupt triggered by the interrupt source. Therefore, take a measure to prevent the false recognition of interrupts during the period from the end of the register clear access until the next interrupt is recognized.

32A.5 Power-Saving Function

This module controls power consumption by using the following two methods:

1. Controlling the SUSPENDM/SLEEPM pin of USBPHY
2. Using clock gating to stop the clock to the host controller or peripheral controller.

32A.5.1 Controlling the SUSPENDM and SLEEPM Pins of the USBPHY

You can expect the following power-saving effects by asserting the SUSPENDM and SLEEPM pins of the USBPHY:

- Reducing the power consumption by the USBPHY
- Reducing the power consumption by the host core by stopping the clocks from the USBPHY

As described at **Section 32A.1.2.5, Suspend extension function**, by default, the SUSPENDM and SLEEPM pins of the USBPHY are not asserted even when EHCI and OHCI are put into the Suspended state.

See **Section 32A.2.4.4(6), Suspend Control Register** and control the relevant registers appropriately.

32A.5.2 Controlling the Clock-Gating Function

See **Section 32A.2.4.4(5), Register Enable/Clock Gating Control Register** and **Section 32A.3.1, Clock Gating Specifications**, then control the relevant registers appropriately.

32A.6 Battery Charging

32A.6.1 Support of charging port

The charging port refers to a port that supplies power in compliance with the Battery Charging Specification. The charging port is usually installed on the host controller.

Charging ports can be generally classified by function as described below.

Type	Function
CDP (Charging Downstream Port)	Downstream port that can supply power in compliance with the Battery Charging Specification. This type of charging port detects a portable device, and after the handshake (for Battery Charging) finishes, it proceeds to the usual device connect sequence (and operates as the usual host).
DCP (Dedicated Charging Port)	Port that provides only power supply function in compliance with the Battery Charging Specification. This type of charging port does not operate as the usual host.
SDP (Standard Downstream Port)	Standard Downstream Port that is not compliant with the Battery Charging Specification. This type of charging port supplies power in the range conforming to the conventional USB 2.0 standard, and operates as the usual host.

32A.6.2 Support of portable device

A portable device refers to a device that is supplied power (or that requests power supply) in compliance with the Battery Charging Specification. The portable port is usually installed in the peripheral controller.

32A.7 Bus Master

32A.7.1 Functional specifications of the bus master

32A.7.1.1 Supported bus master functions

Function as the BUS MASTER	Status
Residual burst after an error response is received	The transfer is not stopped.
1 Kbyte boundary processing	The fixed length burst (INCRx) across 1 Kbyte boundary is not performed.

32A.7.1.2 Issuing requests for different types of bus transfer

MHTRANS[1:0]	MHSIZE[2:0]	MHWRITE	MHBURST[2:0]	Reply	Remarks
IDLE (00b)	—	—	—	—	—
BUSY (01b)	—	—	—	—	Not issued.
NONSEQ (10b)	32-bit (010b)	WRITE	SINGLE	OKAY/ERROR	32-bit transfer is issued.
		READ	INCR4 INCR8 INCR16	OKAY/ERROR	A response error is reported by an interrupt, and the transfer is not stopped.
		8-bit (000b) 16-bit (001b)	WRITE	SINGLE	OKAY/ERROR
	other than the above	—	—	—	Not issued.
SEQ (11b)	32-bit (010b)	WRITE	INCR4	OKAY/ERROR	32-bit transfer is issued.
		READ	INCR8 INCR16	OKAY/ERROR	A response error is reported by an interrupt, and the transfer is not stopped.
		other than the above	—	—	—

32A.7.1.3 Supported responses

Response type	Response	Remarks
OKAY	Enable	Supported.
ERROR	Enable	A response error is reported by an interrupt, and termination of transfer (Early Burst Termination) is not performed.

32A.7.1.4 Protection control information

The value of MHPROT[3:0] can be set in the PROT_TYPE bits (bits [15:12]) in the AHB_BUS_CTR Register (offset: H*208).

Also, when the PROT_MODE bit (bit 8) in the AHB_BUS_CTR Register is set, only the last data transfer in an EHCI/OCHI DMA transfer can be handled as a non-buffered transfer, and other transfers can be handled as buffered transfers.

32A.7.1.5 Maximum burst length

The maximum burst length can be selected from SINGLE, INCR4, INCR8, and INCR16 by using the MAX_BURST_LEN bits (bit[1:0]) in the AHB_BUS_CTR Register (offset: H'208). The maximum burst length is common to reading and writing.

32A.7.1.6 Boundary of transfer data

The value of MHADDR[31:0] bits does not exceed 1 KB boundary during a burst transfer. Also, you can change the address boundary for burst transfer to 16, 32, or 64 bytes by writing a value to the ALIGN_ADDRESS bits (bit[5:4]) in the AHB_BUS_CTR Register (offset: H'208).

32A.7.1.7 Start address of fixed-length INCR burst transfer

The following table lists the values of the lower bits of MHADDR to be applied when a fixed-length INCR burst transfer starts.

ALIGN_ADDRESS Setting	Fixed length Start Address of INCR Burst		
	INCR4	INCR8	INCR16
00b (Aligned at the 1-Kbyte boundary)	MHADDR[9:0] = H'000	MHADDR[9:0] = H'000	MHADDR[9:0] = H'000
	H'004	H'004	H'004
	H'008	H'008	H'008
	H'00C	H'00C	H'00C
	H'010	H'010	H'010
	:	:	:
	H'3D0	H'3C8	H'3B8
	H'3D4	H'3CC	H'3BC
	H'3D8	H'3D0	H'3C0
	H'3DC	H'3D4	
	H'3E0	H'3D8	
	H'3E4	H'3DC	
	H'3E8	H'3E0	
	H'3EC		
	H'3F0		
01b (Aligned at the 16-byte boundary)	MHADDR[3:0] = H'0	-- (Not issued)	-- (Not issued)
10b (Aligned at the 32-byte boundary)	MHADDR[4:0] = H'00	MHADDR[4:0] = H'00	-- (Not issued)
	H'04		
	H'08		
	H'0C		
	H'10		
11b (Aligned at the 64-byte boundary)	MHADDR[5:0] = H'00	MHADDR[5:0] = H'00	MHADDR[5:0] = H'00
	H'04	H'04	
	H'08	H'08	
	H'0C	H'0C	
	H'10	H'10	
	H'14	H'14	
	H'18	H'18	
	H'1C	H'1C	
	H'20	H'20	
	H'24		
	H'28		
	H'2C		
	H'30		

32A.8 Overcurrent Control and VBUS Control

32A.8.1 OVRCUR/VBUSEN pin

Overcurrent detection on the USB port and port power (VBUS) control are performed by the external power IC connected to this module.

This module pin	Input/Output	Level	Description
OVRCURI	Input	L	Overcurrent status was detected.
		H	Overcurrent status was not detected.
VBUSEN	Output	L	Port Power (VBUS) OFF
		H	Port Power (VBUS) ON

32A.8.2 Overcurrent detection timer setting

This module detects overcurrent when the OVRCUR pin remains asserted (0b) for a set period.

The period over which assertion of the OVRCUR pin is required (“overcurrent detection time”) can be set in the following register.

Register	Overcurrent detection/sleep timer setting register (offset: H'310)
Bits	TIMER_OC[19:0]
Initial value	H'3_0D40

The overcurrent detection time can be converted from the setting value of the above register, taking that one bit equal to the internal bus clock (P1 ϕ) cycle.

Therefore, set the value of the above register at initial configuration, considering “the internal bus clock (P1 ϕ) frequency to be used” and “the overcurrent detection time you want to specify”.

32A.8.3 Port Power (VBUS) control specifications

VBUSEN can be controlled by the Port Power bit of the EHCI/OHCI Operational register or by the VBOUT bit of the VBUS Control Register. Which of the above bit controls VBUSEN is determined by the VBUSEN control (VBENCTL) register in USBPHY Control.

Refer to **Section 32.3.4, VBUSEN control register (VBENCTL)**.

When using as Function, VBUSEN should be 0.

Situation	Register	bit		
EHCI control	PORTSC1 (offset: H'164)	bit 12 (PP)		
OHCI control	Global control* ¹	ON setting	HcRhStatus Register (offset: H'050)	bit 16 (Set Global Power)
		OFF setting		bit 0 (Clear Port Status)
	Selective control* ²	ON setting	HcRhPortStatus1 Register (offset: H'054)	bit 8 (Set Port Power)
		OFF setting		bit 9 (Clear Port Power)

Note 1. Global control refers to the status in which the register settings are as follows:

HcRhDescriptorA Register (offset: H'048) bit 8 (PSM) = 0b

or

HcRhDescriptorA Register (offset: H'048) bit 8 (PSM) = 1b

and

HcRhDescriptorB Register (offset: H'04C) bit 17 (PPCM[1]) = 0b

Note 2. Selective control refers to the status in which the register settings are as follows:

HcRhDescriptorA Register (offset: H'048) bit 8 (PSM) = 1b

and

HcRhDescriptorB Register (offset: H'04C) bit 17 (PPCM[1]) = 1b

However, if the register settings are as follows, the VBUSEN pin is always asserted (1b), and the Port Power (VBUS) becomes ON, regardless of the OVRCUR pin's status.

Specify the settings as necessary (for example, your system needs that VBUS is always ON).

EHCI Operational	OHCI Operational				
	HcRhDescriptorA (offset: H'048)			HcRhDescriptorB (offset: H'04C)	Pin Operation
HCSPARAMS (offset: H'104)					
PPC (bit 4)	NOCP (bit 12)	NPS (bit 9)	PSM (bit 8)	PPCM[1] (bit 17)	When the OVRCUR pin is asserted (0b)
0	—	—	—	—	Fixed to 1b
—	1	—	—	—	Fixed to 1b
—	—	1	—	—	Fixed to 1b
1	0	0	0	—	0b
			1	0	
				1	

32A.8.4 Timing Chart for Overcurrent Detection and Recovery

The figure below shows the assertion/de-assertion timings of the OVRCUR and VBUSEN pins signals at overcurrent detection and recovery.

Note that this timing chart is on the assumption that the changes of register settings to fix the Port Power bit to asserted state (see **Section 32A.8.3, Port Power (VBUS) control specifications**) have not been made.

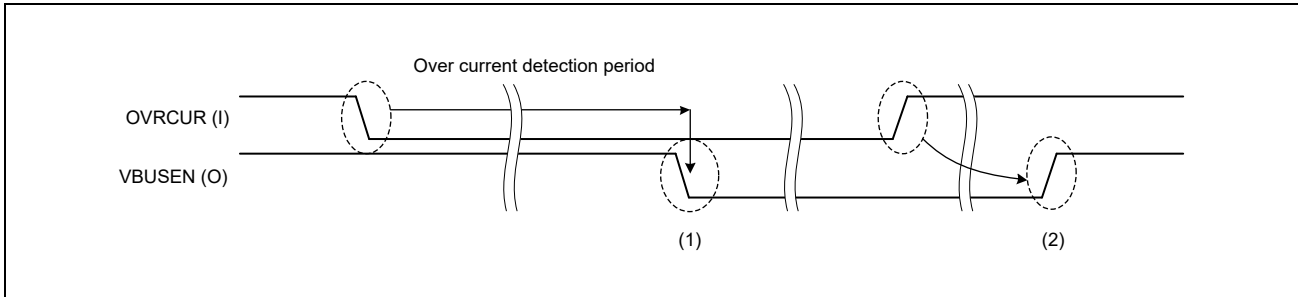

1. When the OVRCUR pin is kept asserted (0b) for the overcurrent detection time, this module determines the occurrence of overcurrent, and then de-asserts the VBUSEN pin (0b).
2. After the overcurrent status has been resolved, and de-assertion of the OVRCUR pin (1b) is confirmed, 1b is written to the Port Power bit described in **Section 32A.8.3, Port Power (VBUS) control specifications** to turn on the Port Power (Vbus).

NOTE

Before the Port Power bit is set by firmware, be sure to check that the OVRCUR pin has been deasserted.

32A.9 Procedure for Setting this Module

32A.9.1 Host/Peripheral Common Setting Sequence

The following shows the necessary sequence common to both host and peripheral modes.

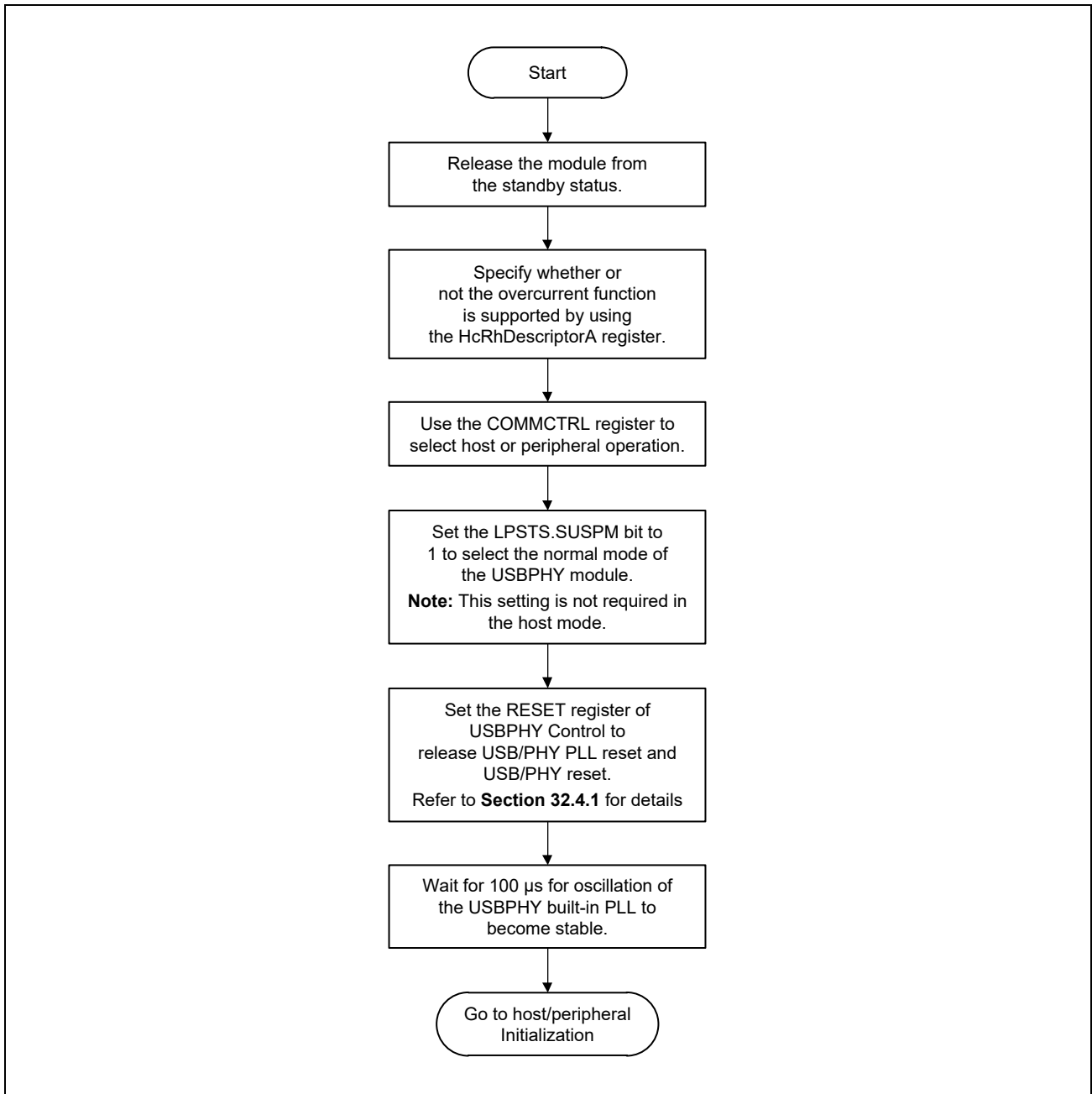

Figure 32A.1 Sequence Common to Both Host and Peripheral Modes

32A.9.2 Initialization Sequence

The following shows the initialization sequence in the Host mode

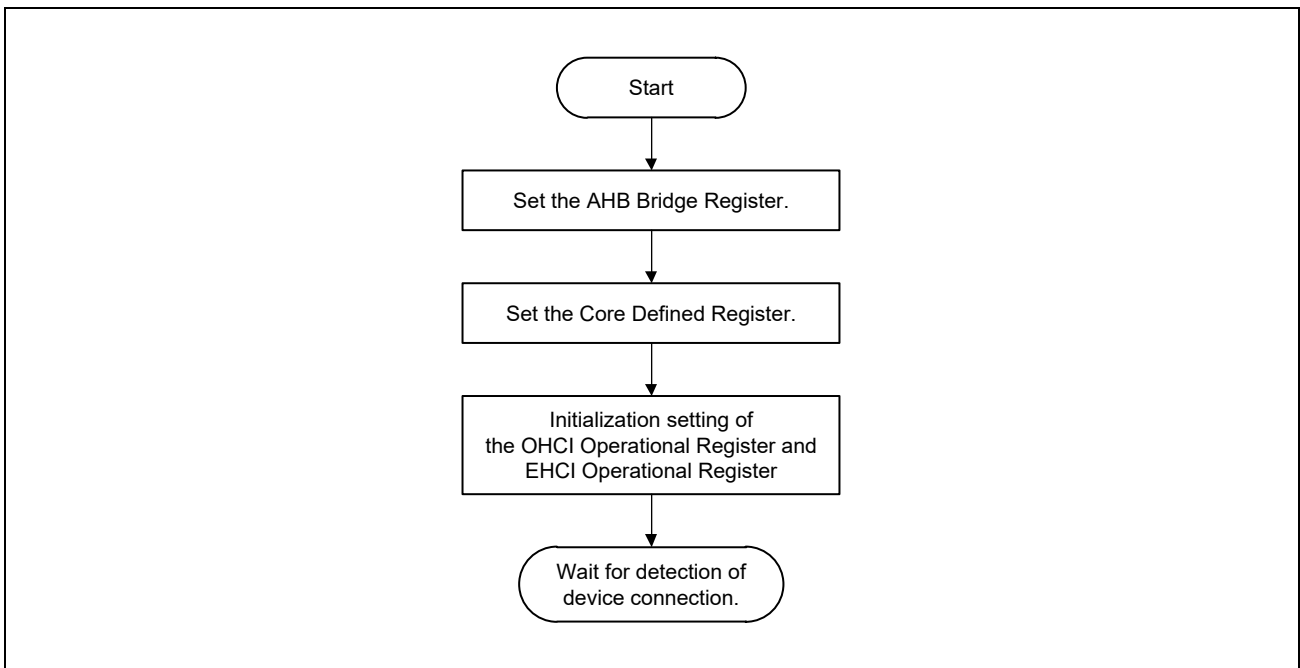

Figure 32A.2 Initialization Sequence

32A.9.3 Flow of Error Handling

While operating this module, if the operation falls into an abnormal state and recovery to the normal flow seems difficult, perform the following steps for reset.

[When an abnormality occurs while EHCI is running]

1. Write 1b to the HCRESET bit (bit 1) of the EHCI Operational Register USBCMD Register (offset: H'120) to execute EHCI software reset.
2. Re-initialize the EHCI Operational Register.

[When an abnormality occurs while OHCI is running]

1. Write 1b to the HCR bit (bit 0) of the OHCI Operational Register HcCommandStatus Register (offset: H'008) to execute OHCI software reset.
2. Re-initialize the OHCI Operational Register.

32B. USB 2.0 Function Module

32B.1 Overview

32B.1.1 Overview

This LSI has two channels of USB 2.0 host/function module. Switching between the host and peripheral functions for each channel is possible by setting the UCOM register.

The setting for battery charging is handled by the host controller even if the peripheral controller is selected.

This chapter describes the peripheral controller. For details on the host/peripheral common circuit and battery charging, see **Section 32A, USB 2.0 Host Module**.

This module is a universal serial bus (USB) controller that has peripheral functions.

This module supports high-speed and full-speed transfer defined by the Universal Serial Bus Specification Revision 2.0.

This module supports all transfer types defined in the USB Specification. This module incorporates 8 Kbytes of buffer memory for data transfer, and can use a maximum of 10 pipes. You can assign any endpoint number to any pipe other than pipe 0 in conformity to the peripheral equipment or system to communicate with.

32B.1.2 Features

32B.1.2.1 Peripheral controller supporting high-speed USB

- (1) On-chip peripheral USB controller

32B.1.2.2 Support of all types of USB transfer

- (1) Supporting all types of USB transfer, including isochronous transfer
- (2) Control transfer
- (3) Bulk transfer
- (4) Interrupt transfer (high-bandwidth transfers not supported)
- (5) Isochronous transfer (high-bandwidth transfers not supported)

32B.1.2.3 Bus interface

- (1) Includes a two-channel DMA interface

32B.1.2.4 Pipe configuration

- (1) 8 Kbytes of buffer memory for USB communications for each channel
- (2) Up to 10 pipes (including the default control pipe) selectable for each channel
- (3) Programmable pipe configuration
- (4) Any endpoint number assignable to pipes other than pipe 0

Table 32B.1 Pipe Settings

PIPE	Transfer Type	Double buffer	Continuous transfer mode	Buffer size
PIPE0	Control	—	—	Fixed to 64 bytes/ 256 bytes (CNTMD = 1)
PIPE1	Iso/Bulk	✓	✓ (Bulk only)	Up to 2 Kbytes
PIPE2	Iso/Bulk	✓	✓ (Bulk only)	Up to 2 Kbytes
PIPE3	Bulk	✓	✓	Up to 2 Kbytes
PIPE4	Bulk	✓	✓	Up to 2 Kbytes
PIPE5	Bulk	✓	✓	Up to 2 Kbytes
PIPE6	Int	—	—	Fixed to 64 bytes
PIPE7	Int	—	—	Fixed to 64 bytes
PIPE8	Int	—	—	Fixed to 64 bytes
PIPE9	Int	—	—	Fixed to 64 bytes

32B.1.2.5 Features of peripheral functions

- (1) Support of high-speed transfer (at 480 Mbps) and full-speed transfer (at 12 Mbps)
- (2) Automatic recognition of high-speed or full-speed operation based on automatic response to the reset handshake
- (3) Control transfer stage monitoring function
- (4) Device state monitoring function
- (5) Automatic response to SET_ADDRESS request
- (6) NAK response interrupt (NRDY)
- (7) SOF interpolation

32B.1.2.6 Features of DMA transfer

DMA transaction mode:	Fetching in both register and link modes are supported.
Interrupt:	Level is supported.
Transfer size:	A transfer size from 1 to 128 bytes can be selected separately for the transfer source and transfer destination.
Skip (scatter/gather) function:	The access size and skip size can be specified separately for the transfer source and destination.
Suspend function:	A running DMA transaction can be suspended temporarily.
Interval function:	The interval of DMA transfers can be specified to control the bus occupancy.

32B.1.2.7 Other functions

- (1) Byte endian swap function to support both big endian and little endian as data formats (when using only CFIFO)
- (2) Transfer ending function using a transaction counter
- (3) SOF pulse output function
- (4) BRDY interrupt event notification timing change function (BFRE)
- (5) Function (SHTNAK) to set NAK in the response PID when transfer ends
- (6) Support of the Link Power Management (LPM) ECN, making available a new low-power-consumption state (L1 state)

32B.1.3 Overview of Functions

32B.1.3.1 Automatic recognition of USB transfer speed

This module automatically recognizes USB transfer speed.

(1) Methods of FIFO buffer memory access

This module supports the two types of access described below to the FIFO buffer memory for USB data transfer.

(a) Access from the CPU

Specify a FIFO port address, and then write data to or read data from the FIFO buffer memory.

(b) Direct memory access (DMA)

Selecting a pipe window and setting the DMA control registers enables writing data to or reading data from the FIFO buffer memory.

32B.1.3.2 USB event

This module notifies the event in USB operation by issuing an interrupt.

You can specify whether to enable notification by interrupt for individual interrupt types and sources through software settings.

32B.1.3.3 USB data transfer

This module performs all types of USB data transfer: control transfer, bulk transfer, interrupt transfer, and isochronous transfer. The following pipe resources are available for individual transfer types:

- (1) One pipe dedicated to control transfer
- (2) Four pipes dedicated to interrupt transfer
- (3) Three pipes dedicated to bulk transfer
- (4) Two pipes selectively used for bulk or isochronous transfer

For each pipe, specify the settings, including transfer type, endpoint number, and maximum packet size, required for USB transfer according to the system.

This module can incorporate up to 8 Kbytes of buffer memory. For the pipes dedicated to bulk transfer and those selectively used for bulk transfer or isochronous transfer, allocate buffer memory and specify a buffer operating mode and other necessary settings according to the system. Setting the buffer operating mode enables high-speed data transfers with fewer interrupts to be performed by using double-buffering and continuous transfer of data packets.

32B.1.3.4 SOF pulse output function

This module has a function to output an SOF pulse to indicate the timing of SOF packet transmission. This module asserts a SOF pulse output signal when an SOF packet is received. This module outputs pulses at regular intervals based on an SOF interpolation timer even when an SOF packet is damaged.

32B.1.4 Restriction matter and Notes

32B.1.4.1 Restriction matter

(1) Restrictions on the USB specifications

It's no support About below of USB 2.0 specification

- HighBandWidth transfer is no support

(2) Restrictions on DMA Master

- DAD = 1 (destination address fixed) and can not use skip transfer of destination side. When forwarding by such setting, movement is unsettled. Should not do such transmission.
- SAD = 1 (source address fixed), and can not use skip transfer of source side. When forwarding by such setting, movement is unsettled. Should not do such transmission.
- DAD = 1 (destination address fixed), and can not use the beat unalign transfer of destination side. When forwarding by such setting, movement is unsettled. Should not do such transmission.
- SAD = 1 (source address fixed), and can not use beat unalign transfer of source side. When forwarding by such setting, movement is unsettled. Should not do such transmission.
- When REQD = 1, SBE = 1 (sweep mode) and compulsion discharge function can not use.

32B.1.4.2 Notes

(1) DMA transfer and passing problem of interrupt signal in DMA Master construction.

(a) Overview

A USBFDMAmn interrupt (m, n = 0, 1) might occur before the last data of DMA transaction is written to the write-target device.

(b) Plan to avoid

A plan to avoid the above problem is indicated below.

Plan to avoid 1) HPROT is set as non bufferable.

According to the DMA mode, set 0 in the DPR[2] bit in the CHEXT_n register or the LDPR[2] bit in the DCTRL register, set the HPROT signal as non bufferable, and then perform the DMA transaction.

If all transfers are set to non bufferable, transfer efficiency might fall.

In such cases, set the most part of transaction as bufferable and perform a transfer, and then perform the last transfer by setting a register set or descriptor as non bufferable.

(2) Setting for battery charging when the peripheral controller is selected

The setting for battery charging is handled by the host controller even if the peripheral controller is selected.

32B.2 Registers

How to read the register table

- (1) Bit number:
- (2) State after reset: Initial state of the register that occurs immediately after a reset “Power on Reset” indicates the initial state at power-on reset.
The state after USB reset is the initial state of the register that occurs when this module detects a USB bus reset.
Significant points regarding reset operation are indicated in notes.
“—” indicates that a user’s setting is retained without this module operation having been performed. “X” indicates that the value is undefined.
- (4) Access condition: The condition to be met when this module accesses the register for an operation.
R: Reading only
W: Writing only
R/W: Reading or writing
R(0): 0-reading only
W(1): 1-writing only
- (5) Name: Bit symbol and bit name
- (6) Function: Description of functions.

<Example of description>

(1) Bit	15	14	13	12	11	10	9	8	7	6	5	4	3	2	1	0
	—	A bit	B bit	C bit	—	—	—	—	—	—	—	—	—	—	—	—
(2) Initial Value	X	0	0	0												
R/W	X	0	—	—												

Bit	Bit Name	Initial Value	R/W	Description
15	—			Nothing is assigned. Fix this bit to 0.
14	A bit		R/W	AAA enable 0: Disables operation 1: Enables operation
13	B bit		R	BBB operation 0: Outputs low-level signal 1: Outputs high-level signal
12	C bit		R(0)/ W(1)	CCC control 0: 1:
	(5)		(4)	(6)

32B.2.1 Base Address

Table 32B.2 Base addresses for each channel of the USB function module

Channel number	Base address
0	H'0_11C6_0000 (AX45MP Address Space)

32B.2.2 List of Registers

Table 32B.3 lists the registers of this module.

Table 32B.3 List of Registers (1/3)

Offset Address	Symbol	Name	Access unit
000	SYSCFG0	System Configuration Control Register 0	16-bit
002	SYSCFG1	System Configuration Control Register 1	16-bit
004	SYSSTS0	System Configuration Status Register	16-bit
008	DVSTCTR0	Device Control Register 0	16-bit
00C	TESTMODE	Test Mode Register	16-bit
014	CFIFO	CFIFO Port Register	8/16/32-bit
016			
020	CFIFOSEL	CFIFO Port Select Register	16-bit
022	CFIFOCTR	CFIFO Port Control Register	16-bit
028	D0FIFOSEL	D0FIFO Port Select Register	16-bit
02A	D0FIFOCTR	D0FIFO Port Control Register	16-bit
02C	D1FIFOSEL	D1FIFO Port Select Register	16-bit
02E	D1FIFOCTR	D1FIFO Port Control Register	16-bit
030	INTENB0	Interrupt Enable Register 0	16-bit
036	BRDYENB	BRDY Interrupt Enable Register	16-bit
038	NRDYENB	NRDY Interrupt Enable Register	16-bit
03A	BEMPENB	BEMP Interrupt Enable Register	16-bit
03C	SOFCFG	SOF Output Configuration Register	16-bit
040	INTSTS0	Interrupt Status Register 0	16-bit
046	BRDYSTS	BRDY Interrupt Status Register	16-bit
048	NRDYSTS	NRDY Interrupt Status Register	16-bit
04A	BEMPSTS	BEMP Interrupt Status Register	16-bit
04C	FRMNUM	Frame Number Register	16-bit
04E	UFRMNUM	Micro Frame Number Register	16-bit
050	USBADDR	USB Address Register	16-bit
054	USBREQ	USB Request Type Register	16-bit
056	USBVAL	USB Request Value Register	16-bit
058	USBINDX	USB Request Index Register	16-bit
05A	USBLENG	USB Request Length Register	16-bit
05C	DCPCFG	DCP Configuration Register	16-bit
05E	DCPMAXP	DCP Max. Packet Size Register	16-bit

Table 32B.3 List of Registers (2/3)

Offset Address	Symbol	Name	Access unit
060	DCPCTR	DCP Control Register	16-bit
064	PIPESEL	Pipe Window Select Register	16-bit
068	PIPECFG	Pipe Configuration Register	16-bit
06A	PIPEBUF	Pipe Buffer Setting Register	16-bit
06C	PIPEMAXP	Pipe Max. Packet Size Register	16-bit
06E	PIPEPERI	Pipe Cycle Control Register	16-bit
070	PIPE1CTR	PIPE1 Control Register	16-bit
072	PIPE2CTR	PIPE2 Control Register	16-bit
074	PIPE3CTR	PIPE3 Control Register	16-bit
076	PIPE4CTR	PIPE4 Control Register	16-bit
078	PIPE5CTR	PIPE5 Control Register	16-bit
07A	PIPE6CTR	PIPE6 Control Register	16-bit
07C	PIPE7CTR	PIPE7 Control Register	16-bit
07E	PIPE8CTR	PIPE8 Control Register	16-bit
080	PIPE9CTR	PIPE9 Control Register	16-bit
090	PIPE1TRE	PIPE1 Transaction Counter Enable Register	16-bit
092	PIPE1TRN	PIPE1 Transaction Counter Register	16-bit
094	PIPE2TRE	PIPE2 Transaction Counter Enable Register	16-bit
096	PIPE2TRN	PIPE2 Transaction Counter Register	16-bit
098	PIPE3TRE	PIPE3 Transaction Counter Enable Register	16-bit
09A	PIPE3TRN	PIPE3 Transaction Counter Register	16-bit
09C	PIPE4TRE	PIPE4 Transaction Counter Enable Register	16-bit
09E	PIPE4TRN	PIPE4 Transaction Counter Register	16-bit
0A0	PIPE5TRE	PIPE5 Transaction Counter Enable Register	16-bit
0A2	PIPE5TRN	PIPE5 Transaction Counter Register	16-bit
0D0	DEVADD0	Device Address 0 Configuration Register	16-bit
0D2	DEVADD1	Device Address 1 Configuration Register	16-bit
0D4	DEVADD2	Device Address 2 Configuration Register	16-bit
0D6	DEVADD3	Device Address 3 Configuration Register	16-bit
0D8	DEVADD4	Device Address 4 Configuration Register	16-bit
0DA	DEVADD5	Device Address 5 Configuration Register	16-bit
0DC	DEVADD6	Device Address 6 Configuration Register	16-bit
0DE	DEVADD7	Device Address 7 Configuration Register	16-bit
0E0	DEVADD8	Device Address 8 Configuration Register	16-bit
0E2	DEVADD9	Device Address 9 Configuration Register	16-bit
0E4	DEVADDA	Device Address A Configuration Register	16-bit
100	LPCTRL	Low Power Control Register	16-bit
102	LPSTS	Low Power Status Register	16-bit
104	PHYFUNCTR	PHY Function Control Register	16-bit
10A	PHYOTGCTR	PHY OTG Control Register	16-bit
144	PL1CTRL1	Peripheral L1 Control Register 1	16-bit
146	PL1CTRL2	Peripheral L1 Control Register 2	16-bit
400	N0SA_0	Next0 Source Address Register 0	32-bit
404	N0DA_0	Next0 Destination Address Register 0	32-bit
408	N0TB_0	Next0 Transaction Byte Register 0	32-bit

Table 32B.3 List of Registers (3/3)

Offset Address	Symbol	Name	Access unit
40C	N1SA_0	Next1 Source Address Register 0	32-bit
410	N1DA_0	Next1 Destination Address Register 0	32-bit
414	N1TB_0	Next1 Transaction Byte Register 0	32-bit
418	CRSA_0	Current Source Address Register 0	32-bit
41C	CRDA_0	Current Destination Address Register 0	32-bit
420	CRTB_0	Current Transaction Byte Register 0	32-bit
424	CHSTAT_0	Channel Status Register 0	32-bit
428	CHCTRL_0	Channel Control Register 0	32-bit
42C	CHCFG_0	Channel Configuration Register 0	32-bit
430	CHITVL_0	Channel Interval Register 0	32-bit
434	CHEXT_0	Channel Extension Register 0	32-bit
438	NXLA_0	Next Link Address Register 0	32-bit
43C	CRLA_0	Current Link Address Register 0	32-bit
440	N0SA_1	Next0 Source Address Register 1	32-bit
444	N0DA_1	Next0 Destination Address Register 1	32-bit
448	N0TB_1	Next0 Transaction Byte Register 1	32-bit
44C	N1SA_1	Next1 Source Address Register 1	32-bit
450	N1DA_1	Next1 Destination Address Register 1	32-bit
454	N1TB_1	Next1 Transaction Byte Register 1	32-bit
458	CRSA_1	Current Source Address Register	32-bit
45C	CRDA_1	Current Destination Address Register 1	32-bit
460	CRTB_1	Current Transaction Byte Register 1	32-bit
464	CHSTAT_1	Channel Status Register 1	32-bit
468	CHCTRL_1	Channel Control Register 1	32-bit
46C	CHCFG_1	Channel Configuration Register 1	32-bit
470	CHITVL_1	Channel Interval Register 1	32-bit
474	CHEXT_1	Channel Extension Register 1	32-bit
478	NXLA_1	Next Link Address Register 1	32-bit
47C	CRLA_1	Current Link Address Register 1	32-bit
600	SCNT_0	Source Continuous Register 0	32-bit
604	SSKP_0	Source Skip Register 0	32-bit
608	DCNT_0	Destination Continuous Register 0	32-bit
60C	DSKP_0	Destination Skip Register 0	32-bit
620	SCNT_1	Source Continuous Register 1	32-bit
624	SSKP_1	Source Skip Register 1	32-bit
628	DCNT_1	Destination Continuous Register 1	32-bit
62C	DSKP_1	Destination Skip Register 1	32-bit
700	DCTRL	DMA Control Register	32-bit
704	DSCITVL	Descriptor Interval	32-bit
710	DST_EN	DMA Status EN Register	32-bit
714	DST_ER	DMA Status ER Register	32-bit
718	DST_END	DMA Status END Register	32-bit
71C	DST_TC	DMA Status TC Register	32-bit
720	DST_SUS	DMA Status SUS Register	32-bit

32B.2.3 System Configuration Control Registers

32B.2.3.1 System Configuration Control Register 0 [SYSCFG0] <Address: H'000>

Bit	15	14	13	12	11	10	9	8	7	6	5	4	3	2	1	0
	—	—	—	—	—	—	—	CNEN	HSE	—	DRPD	DPRPU	—	—	—	USBE
Initial Value	0	0	0	0	0	0	0	0	0	0	1	0	0	0	0	0
R/W	R	R	R	R	R	R	R	R/W	R/W	R	R/W	R/W	R	R	R	R/W

Bit	Bit Name	Initial Value	R/W	Description
15 to 9	—	All 0	R	Nothing is assigned to these bits. Fix these bits to 0.
8	CNEN	0	R/W	This bit prohibits or enables single-ended receiver operation. 0: Single-ended receiver operation prohibited 1: Single-ended receiver operation enabled
7	HSE	0	R/W	This bit prohibits or enables High-Speed operation. 0: High-Speed operation prohibited (Full-Speed) 1: High-Speed operation enable (The controller detects the communication speed.)
6	—	0	R	Nothing is assigned to this bit. Fix this bit to 0.
5	DRPD	1	R/W	D+/D- line resistor control Set this bit to 0 to use this module. For details, see Control of USB Data Bus Resistors.
4	DPRPU	0	R/W	D+ line resistor control This bit prohibits or enables D+ line pull-up for the peripheral controller function. For details, see Control of USB Data Bus Resistors. 0: Pull Up prohibited 1: Pull Up enabled
3 to 1	—	All 0	R	Nothing is assigned to these bits. Fix these bits to 0.
0	USBE	0	R/W	USB block operation prohibited This bit prohibits or enables USB block operation. 0: USB block operation prohibited 1: USB block operation enabled

Note: Data can be written to and read from this register even while the UTMI+PHY clock is stopped. However, if a value is set while the UTMI+PHY clock is stopped, the corresponding function takes effect after the oscillation of UTMI+PHY clock starts.

(1) Single-ended receiver operation enable (CNEN) bit

Setting this bit enables the single-ended receiver to operate. This bit is intended to prevent damage by inrush current that can be caused when the single-ended receiver in unattached status goes floating. This bit also allows the LNST bit to be referenced.

Set this bit when VBUS is detected as the result of a VBUS interrupt. Clear this bit when VBUS is removed.

(2) High-speed operation enable (HSE) bit

Setting this bit enables the high-speed operation. When this bit is 1, this module performs a high-speed or full-speed operation according to the result of reset handshake.

- When the HSE bit is 0, this module performs a full-speed operation.
- When the HSE bit is 1, this module executes the reset handshake protocol, and then automatically performs a high-speed or full-speed operation according to the result of reset handshake.

Rewriting the value of this bit must be done when the DPRPU bit is 0.

(3) D+/D- line resistor control (DRPD or DPRPU) bit

Table 32B.4 shows available settings of the resistors for the USB data bus. Use the DPRPU bit to select the USB data bus resistors.

Table 32B.4 Control of USB Data Bus Resistors

Setting		Control of USB Data Bus Resistors		
DRPD	DPRPU	D- Line	D+ Line	Remarks
0	0	Open	Open	
0	1	Open	Pull-Up	Specify the settings as shown in the left.
1	0	Pull-Down	Pull-Down	Initial state (When power on reset is canceled)
1	1	Pull-Down	Pull-Up	Setting prohibited

(a) D+ pull-up resistor control (DPRPU) bit

Setting this bit enables this module to notify the USB host of attaching by pulling up the D+ line voltage to 3.3 V.

Clearing this bit enables this module to let the USB host know that the device has been detached by stopping pulling up the D+ line voltage.

(4) USB block operation enable (USBE) bit

This bit enables or disables the operation of the USB block of this module.

When this bit is changed from 1 to 0, this module initializes the bits shown in **Table 32B.5**.

Table 32B.5 Register Bits That Are Initialized by Writing 0 to the USBE Bit

Register Name	Bit Name
SYSSTS0	LNST
DVSTCTR0	RHST
INTSTS0	DVSQ
USBADDR	USBADDR
USBREQ	bRequest bmRequestType
USBVAL	wValue
USBINDX	wIndex
USBLENG	wLength

Note: Changing the value of this bit must be done when the SUSPENDM bit is 1 and after the oscillation of UTMI+PHY clock starts.

32B.2.3.2 System Configuration Control Register 1 [SYSCFG1] <Address: H'002>

Bit	15	14	13	12	11	10	9	8	7	6	5	4	3	2	1	0
	—	—	—	—	—	—	—	—	—	—	BWAIT					
Initial Value	0	0	0	0	1	1	1	1	0	0	0	0	1	1	1	1
R/W	R	R	R	R	R	R	R	R	R	R	R/W	R/W	R/W	R/W	R/W	R/W

Bit	Bit Name	Initial Value	R/W	Description
15 to 12	—	All 0	R	Nothing is assigned to these bits. Fix these bits to 0.
11 to 8	—	H'F	R	Nothing is assigned to these bits. Fix these bits to 0.
7, 6	—	All 0	R	Nothing is assigned to these bits. Fix these bits to 0.
5 to 0	BWAIT	H'0F	R/W	CPU bus access wait specification These bits specify the number of wait cycles for the access to this module. 000000: 0 wait cycles (2 access cycles) : 000010: 2 wait cycles (4 access cycles) : 000100: 4 wait cycles (6 access cycles) : 001111: 15 wait cycles (17 access cycles) (default) : 111111: 63 wait cycles (65 access cycles)

(1) CPU bus access wait specification (BWAIT) bits

These bits specify the wait cycles for the access to the HPB.

The following restriction is placed on the cycle of the access to the registers at address H'04 or after of this module:

Restriction on wait cycle: The cycle of continuous accesses to registers of this module must be at least 67 ns.

To comply with this restriction, you must control the number of wait cycles with the internal bus clock (P1 ϕ) frequency.

The default of wait cycles is 17 clock cycles (maximum limit). Select an optimum setting.

This setting is also applied to accesses to FIFO port registers. The maximum speeds of accesses to FIFO ports are as follows:

MBW = 10 (32-bit access width): Max 60 MBytes/sec

MBW = 01 (16-bit access width): Max 30 MBytes/sec

MBW = 00 (8-bit access width): Max 15 MBytes/sec

32B.2.4 System Configuration Status

32B.2.4.1 System Configuration Status Register (SYSSTS0) <Address: H'004>

Bit	15	14	13	12	11	10	9	8	7	6	5	4	3	2	1	0	
	—	—	—	—	—	—	—	—	—	—	—	—	—	—	LNST		
Initial Value	—	—	0	0	0	0	0	0	0	0	0	0	0	0	—	0	0
R/W	R	R	R	R	R	R	R	R	R	R	R	R	R	R	R	R	R

Bit	Bit Name	Initial Value	R/W	Description
15 to 2	—	See above	R	Nothing is assigned to these bits. Fix these bits to 0.
1, 0	LNST	All 0	R	USB Line status monitor The USB line status is displayed.

Note: See the detailed description.

(1) Line status monitor (LNST) bits

Table 32B.6 shows the line status of the USB data bus of this module. This module monitors the line status (status of the D+ and D- lines) of the USB data bus in the LNST bits of the SYSSTS0 register.

Referencing the LNST bits must be done only after the USBE bit is set and attaching is performed (the DPRPU bit is set).

Table 32B.6 Line Status of USB Data Bus

LNST [1]	LNST [0]	Full-Speed operation	High-Speed operation	Chirp operation
0	0	SE0	Squelch	Squelch
0	1	J State	Unsquench	Chirp J
1	0	K State	Invalid	Chirp K
1	1	SE1	Invalid	Invalid

Note: Chirp: State in which high-speed operation is enabled (HSE = 1) and the reset handshake protocol is being executed
 Squelch: SE0 or idle state
 Unsquench: High-speed J or high-speed K state
 Chirp J: Chirp J State
 Chirp K: Chirp K State

32B.2.5 USB Signal Control Registers

32B.2.5.1 Device State Control Register 0 [DVSTCTR0] <Address: H'008>

Bit	15	14	13	12	11	10	9	8	7	6	5	4	3	2	1	0
	—	—	—	—	—	—	—	WKUP	—	—	—	—	—	RHST		
Initial Value	0	0	0	0	0	0	0	0	0	0	0	0	0	0	0	0
R/W	R	R	R	R	R	R	R	R/W(1)	R	R	R	R	R	R	R	R

Bit	Bit Name	Initial Value	R/W	Description
15	—	0	R/W	Reserved. When read, the initial value is read. When writing, be sure to write the initial value. Operation is not guaranteed if a value other than the initial value is written.
14 to 9	—	All 0	R	Nothing is assigned to these bits. Fix these bits to 0.
8	WKUP	0	R/W (1)	Remote wakeup output This bit prohibits or enables Remote wakeup (resume signal output). 0: Remote wakeup signal is not output. 1: Remote wakeup signal is output.
7 to 3	—	All 0	R	Nothing is assigned to these bits. Fix these bits to 0.
2 to 0	RHST	All 0	R	Reset handshake This bit indicates the reset handshake status.

Note: See the detailed description.

(1) Remote wakeup (resume signal output) enable (WKUP) bit

When this bit is set, this module outputs the remote wakeup signal to the USB.

This module manages the time of remote wakeup signal output. When the WKUP bit is set, this module outputs the K state for 10 ms, and then clears the WKUP bit.

The USB Specification requires the USB idle state to be retained for at least 5 ms before the remote wakeup signal is sent. Therefore, even if the WKUP bit is set immediately after the suspended state is detected, this module waits for 2 ms, and then outputs the K state.

Writing 1 to the WKUP bit must be done only when the device is in the suspended state ($DVSQ = 1xx$) and remote wakeup is allowed by the USB host.

When setting the WKUP bit, do not stop the internal clock even if the device is in the suspended state. (Write 1 to the WKUP bit when the SUSPM bit is 1.)

When the WKUP bit is set at a transition to the L1 state, this module outputs the K state for 50 μ s, and then clears the WKUP bit. In the L1 state, setting the WKUP bit must be done only when the $DVSQ[4]$ bit is 1.

(2) Reset handshake status (RHST) bits

This module outputs the result of reset handshake to this bit. **Table 32B.7** lists the results of reset handshake.

Table 32B.7 Reset Handshake Status

Bus State	Value of RHST Bit
Powered or disconnected state	000
Reset handshake in process	100
Full-speed connection	010
High-speed connection	011

If the HSE bit is 1, the RHST bits indicate 100 when this module detects a USB bus reset. Then, after this module has output Chirp K, these bits indicate 011 when this module detects Chirp JK from the USB host three times. If the status is not fixed to High-Speed within 2.5 ms after Chirp K is output, these bits indicate 010.

If the HSE bit is 0, the RHST bits indicate 010 when this module detects a bus reset.

After this module has detected a USB reset, a DVST interrupt occurs when the value of the RHST bits is fixed to 010 or 011.

32B.2.6 Test Mode Register

32B.2.6.1 USB Test Mode Register [TESTMODE] <Address: H'00C>

Bit	15	14	13	12	11	10	9	8	7	6	5	4	3	2	1	0
	—	—	—	—	—	—	—	—	—	—	—	—	UTST			
Initial Value	0	0	0	0	0	0	0	1	0	0	0	0	0	0	0	0
R/W	R/W	R/W	R/W	R/W	R/W	R/W	R/W	R/W	R/W	R/W	R/W	R/W	R/W	R/W	R/W	R/W

Bit	Bit Name	Initial Value	R/W	Description
15	—	0	R	Nothing is assigned to this bit. Fix this bit to 0.
14	—	0	R/W	Reserved. When read, the initial value is read. When writing, be sure to write the initial value. Operation is not guaranteed if a value other than the initial value is written.
13, 12	—	All 0	R	Nothing is assigned to these bits. Fix these bits to 0.
11	—	0	R/W	Reserved. When read, the initial value is read. When writing, be sure to write the initial value. Operation is not guaranteed if a value other than the initial value is written.
10 to 4	—	H'10	R	Nothing is assigned to these bits. Fix these bits to 0.
3 to 0	UTST	All 0	R/W	Test mode See the detailed description.

(1) Test mode (UTST) bits

When a value is written to these bits, this module outputs a USB test signal during high-speed operation.

Table 32B.8 lists the test modes of this module.

Table 32B.8 List of test mode operation

Test mode	Value of UTST Bits
Normal operation	0000
Test_J	0001
Test_K	0010
Test_SE0_NAK	0011
Test_Packet	0100
Test_Force_Enable	—
Reserved	0101 to 0111

Write a value to these bits according to the SetFeature request sent from the USB host during high-speed communication. When these bits contain a value from 0001 to 0100, this module does not enter the suspended state.

To perform a normal USB communication after setting a test mode, perform Power on reset.

32B.2.7 FIFO Port Registers

32B.2.7.1 CFIFO Port Register [CFIFO] <Address: H'014>

Bit	31	30	29	28	27	26	25	24	23	22	21	20	19	18	17	16
	FIFOPORT (Low)															
Initial Value	0	0	0	0	0	0	0	0	0	0	0	0	0	0	0	0
R/W	R/W	R/W	R/W	R/W	R/W	R/W	R/W	R/W	R/W	R/W	R/W	R/W	R/W	R/W	R/W	R/W

32B.2.7.2 CFIFO Port Register [CFIFO] <Address: H'016>

Bit	15	14	13	12	11	10	9	8	7	6	5	4	3	2	1	0
	FIFOPORT (High)															
Initial Value	0	0	0	0	0	0	0	0	0	0	0	0	0	0	0	0
R/W	R/W	R/W	R/W	R/W	R/W	R/W	R/W	R/W	R/W	R/W	R/W	R/W	R/W	R/W	R/W	R/W

Bit	Bit Name	Initial Value	R/W	Description
31 to 0	FIFOPORT	All 0	R/W	FIFO port These bits are accessed to read received data from the FIFO buffer or to write send data to the FIFO buffer.

(1) FIFO port control bits (for FIFOPORT)

The send/receive buffer memory of this module has a FIFO structure (FIFO buffer). Use FIFO port registers to access the FIFO buffer. The FIFO port consists of the port register (CFIFO) to read data from and write data to the FIFO buffer, the register (CFIFOSEL) to select the pipe to be allocated to the FIFO port, and the control register (CFIFOCTR).

Individual FIFO ports have the following features:

1. The CFIFO port must be used to access the FIFO buffer through the DCP.
2. When functions specific to FIFO ports are used, the pipe number (selected pipe) specified in the CURPIPE bits cannot be changed.
3. The registers configured for a FIFO port do not affect any other FIFO ports.
4. The FIFO buffer memory can be accessed by either the CPU or SIE. Access by the CPU is not possible while the SIE has the right of access to the FIFO buffer memory.

(2) FIFO port bits (CFIFO)

When one of these registers is accessed, this module accesses the FIFO buffer allocated to the pipe number specified in the CURPIPE bits in the corresponding pipe select register (CFIFOSEL).

These registers can be accessed only when the FRDY bit of the respective control registers (CFIFOCTR) is 1 (or when the UCL_Dx_DREQ output is asserted by this module).

The valid bits of these registers vary depending on the values of the NBW and BIGEND bits. The valid bits are shown in **Table 32B.9** to **Table 32B.11**.

Table 32B.9 Endian Operation in 32-Bit Access (When MBW = 10)

BIGEND	b31 to b24	b23 to b16	b15 to b8	b7 to b0
0	N + 3 address	N + 2 address	N + 1 address	N + 0 address
1	N + 0 address	N + 1 address	N + 2 address	N + 3 address

Table 32B.10 Endian Operation in 16-Bit Access (When MBW = 01)

BIGEND	b31 to b24	b23 to b16	b15 to b8	b7 to b0
0	Writing: invalid Reading: prohibited* ¹		even-numbered address	odd-numbered address
1	even-numbered address	odd-numbered address	Writing: invalid Reading: prohibited* ¹	

Table 32B.11 Endian Operation in 8-Bit Access (When MBW = 00)

BIGEND	b31 to b24	b23 to b16	b15 to b8	b7 to b0
0	Writing: invalid Reading: prohibited* ¹			Writing: valid Reading: valid
1	Writing: valid Reading: valid	Writing: invalid Reading: prohibited* ¹		

Note 1. Reading words or bytes from an invalid register is prohibited.

32B.2.7.3 CFIFO Port Select Register [CFIFOSEL] <Address: H'020>

Bit	15	14	13	12	11	10	9	8	7	6	5	4	3	2	1	0
	RCNT	REW	—	—	MBW		—	BIGEND	—	—	ISEL	—	CURPIPE			
Initial Value	0	0	0	0	0	0	0	0	0	0	0	0	0	0	0	0
R/W	R/W	R(0)/W	R	R	R/W	R/W	R	R/W	R	R	R/W	R	R/W	R/W	R/W	R/W

Bit	Bit Name	Initial Value	R/W	Description
15	RCNT	0	R/W	Read count mode This bit specifies DTLN read mode for the CFIFOCTR register. 0: Clears the DTLN bits when all received data is read. 1: Decrements the value of the DTLN bits each time received data is read.
14	REW	0	R(0)/W	Buffer pointer rewind Set this bit to 1 to rewind the buffer pointer. 0: Does not rewind the buffer pointer. 1: Rewinds the buffer pointer.
13, 12	—	All 0	R	Nothing is assigned to these bits. Fix these bits to 0.
11, 10	MBW	0	R/W	CFIFO port access bit width This bit specifies the bit width for access to the CFIFO port. 00: 8-bit width 01: 16-bit width 10: 32-bit width 11: Setting prohibited
9	—	0	R	Nothing is assigned to this bit. Fix this bit to 0.
8	BIGEND	0	R/W	FIFO port byte endian control This bit specifies the byte endian of the CFIFO port. 0: Little endian 1: Big endian
7, 6	—	All 0	R	Nothing is assigned to these bits. Fix these bits to 0.
5	ISEL	0	R/W	FIFO port access direction with DCP selected This bit specifies the FIFO port access direction when DCP is selected for the CURPIPE bits. 0: Selects reading of buffer memory. 1: Selects writing of buffer memory.
4	—	0	R	Nothing is assigned to this bit. Fix this bit to 0.
3 to 0	CURPIPE	All 0	R/W	FIFO port access pipe specification This bit specifies the pipe number used for accessing the CFIFO port. 0000: DCP 0001: PIPE1 0010: PIPE2 ↓ 1000: PIPE8 1001: PIPE9 ↓ 1110: PIPE14 1111: PIPE15

(1) Read count mode (RCNT) bit

When this bit is 0, this module clears the DTLN bits in the CFIFOCTR register when all received data has been read from the FIFO buffer allocated to the pipe (selected pipe) specified in the CURPIPE bits (or, in the case of double-buffer configuration, when all relieved data has been read from one buffer).

With this bit is 1, this module decrements the value of the DTLN bits in the CFIFOCTR register each time received data is read from the FIFO buffer allocated to the specified pipe.

(2) Buffer pointer rewind (REW) bit

When this bit is set during data reading from the FIFO buffer while the selected pipe is in the receiving direction, reading can be restarted from the first data in the FIFO buffer (or, in the case of a double-buffer configuration, rereading can be started from the first data in the FIFO buffer being read).

Do not set this bit at the same time as changing the value of the CURPIPE bits. Before setting this bit, always check that the FRDY bit is 1.

If you want to redo writing to the FIFO buffer from the first data in the FIFO buffer when the selected PIPE is in the sending direction, use the BCLR bit.

(3) CFIFO port access bit width (MBW) bits

These bits are used to specify the bit width for the access to the CFIFO port.

If you start reading after setting a value in these bits when the pipe specified in the CURPIPE bits is in the receiving direction, do not change the value of these bits until data is all read.

Also, to set a value in these bits when the pipe specified in the CURPIPE bits is in the receiving direction, temporarily change the original value of the CURPIPE bits to a different value, and then set the values of the CURPIPE and MBW bits at the same time.

For how to change the value of the CURPIPE bits, see the description of the CURPIPE bits.

When the pipe specified in the CURPIPE bits is in the sending direction, you cannot change the bit width from 8 bits to 16 bits or 32 bits or from 16 bits to 32 bits while writing to the buffer memory is in process.

Even with the 16-bit width or 32-bit width setting, you can write data also to odd bytes by using byte access control.

(4) FIFO port byte endian control (BIGEND) bit

This bit is used to specify the byte endian of the CFIFO port.

For details see **Section 32B.2.7.2(1), FIFO port control bits (for FIFOPORT)**.

(5) FIFO port access direction with DCP selected (ISEL) bit

To change the value of this bit when the specified pipe is DCP, write a value to this bit, read the bit, and then check that the written value is the same as the read value before proceeding to the next processing.

If the value of the bit is changed in the middle of an access to the FIFO buffer, the access is held. Therefore, the same access can be resumed after these bits are restored to the original value.

Set this bit simultaneously with setting of the CURPIPE bits.

(6) FIFO port access pipe specification (CURPIPE) bits

These bits are used to specify the pipe number of the pipe through which to read or write data via the CFIFO port.

If you change the value of these bits, write a desired value to these bits, read these bits, and then check that the written value is the same as the read value before proceeding to the next processing.

If the value of these bits is changed in the middle of an access to the FIFO buffer, the access is held. Therefore, the same access can be resumed after these bits are restored to the original value.

32B.2.7.4 D0FIFO Port Select Register [D0FIFOSEL] <Address:H'028> D1FIFO Port Select Register [D1FIFOSEL] <Address:H'02C>

Bit	15	14	13	12	11	10	9	8	7	6	5	4	3	2	1	0
	RCNT	REW	DCLRM	DREQE	MBW		—	—	—	—	—	—	CURPIPE			
Initial Value	0	0	0	0	0	0	0	0	0	0	0	0	0	0	0	0
R/W	R/W	R(0)/W	R/W	R/W	R/W	R/W	R/W	R/W	R/W	R/W	R/W	R/W	R/W	R/W	R/W	R/W

Bit	Bit Name	Initial Value	R/W	Description
15	RCNT	0	R/W	Read count mode This bit specifies Dx_FIFOCTR DTLN read mode. 0: Clears the DTLN bits when all received data is read. 1: Decrements the value of the DTLN bits each time received data is read.
14	REW	0	R(0)/W	Buffer pointer rewind Set this bit to 1 to rewind the buffer pointer. 0: Does not rewind the buffer pointer. 1: Rewinds the buffer pointer.
13	DCLRM	0	R/W	Automatic buffer memory clear mode after reading data through the specified pipe This bit prohibits or enables automatic buffer memory clear after data is read through the specified pipe. 0: Automatic FIFO buffer clear prohibited 1: Automatic FIFO buffer clear enabled
12	DREQE	0	R/W	UCL_Dx_DREQ output enable This bit prohibits or enables the output of the UCL_Dx_DREQ signal. 0: Output prohibited 1: Output enabled
11, 10	MBW	All 0	R/W	DxFIFO port access bit width This bit specifies the bit width for access to the DxFIFO port. 00: 8-bit width 01: 16-bit width 10: 32-bit width 11: Setting prohibited
9 to 4	—	All 0	R	Nothing is assigned to these bits. Fix these bits to 0.
3 to 0	CURPIPE	All 0	R/W	FIFO port access pipe specification 0000: No specification 0001: PIPE1 0010: PIPE2 ↓ 1000: PIPE8 1001: PIPE9

(1) Read count mode (RCNT) bit

When this bit is 0, this module clears the DTLN bits in the Dx_FIFOCTR register when all received data has been read from the FIFO buffer allocated to the pipe (selected pipe) specified in the CURPIPE bits (or, in the case of double-buffer configuration, when all relieved data has been read from one buffer).

With this bit is 1, this module decrements the value of the DTLN bits in the Dx_FIFOCTR register each time received data is read from the FIFO buffer allocated to the specified pipe.

(2) Buffer pointer rewind (REW) bit

When this bit is set during data reading from the FIFO buffer while the selected pipe is in the receiving direction, reading can be restarted from the first data in the FIFO buffer (or, in the case of a double-buffer configuration, rereading can be started from the first data in the FIFO buffer being read).

Do not set this bit at the same time as changing the value of the CURPIPE bits. Before setting this bit, always check that the FRDY bit is 1.

If you want to redo writing to the FIFO buffer from the first data in the FIFO buffer when the selected PIPE is in the sending direction, use the BCLR bit.

(3) Automatic FIFO buffer clear enable (DCLRM) bit

This bit is used to enable or disable the mode to automatically clear the FIFO buffer memory after reading data from the specified pipe. With this bit set, this module performs the “BCLR = 1” processing on the FIFO buffer, if a zero-length packet is received when the FIFO buffer allocated to the specified pipe is empty or if data reading ends because a short packet is received when the BFRE bit is 1.

Always clears this bit when you use this module with the BRDYM bit set.

(4) UCL_Dx_DREQ output enable (DREQE) bit

This bit is used to enable or disable the output of the UCL_Dx_DREQ signal.

When enabling the UCL_Dx_DREQ signal, set this bit always after setting a value in the CURPIPE bits. When changing the value of the CURPIPE bits, change the value always after clearing this bit.

(5) DxFIFO port access bit width (MBW) bits

These bits are used to specify the bit width for the access to the DxFIFO port. For details, see **Section 32B.2.7.3(3), CFIFO port access bit width (MBW) bits.**

(6) FIFO port access pipe specification (CURPIPE) bits

These bits are used to specify the pipe number through which to read or write data via the DxFIFO port.

If you change the value of these bits, write a desired value to these bits, read these bits, and then check that the written value is the same as the read value before proceeding to the next processing.

Do not specify the same pipe number for the CURPIPE bits in the CFIFOSEL, D0FIFOSEL, and D1FIFOSEL registers. If the value of these bits is changed in the middle of an access to the FIFO buffer, the access is held. Therefore, the same access can be resumed after these bits are restored to the original value.

32B.2.7.5 CFIFO Port Control Register [CFIFOCTR] <Address: H'022> D0FIFO Port Control Register [D0FIFOCTR] <Address: H'02A> D1FIFO Port Control Register [D1FIFOCTR] <Address: H'02E>

Bit	15	14	13	12	11	10	9	8	7	6	5	4	3	2	1	0
	BVAL	BCLR	FRDY	—	DTLN											
Initial Value	0	0	0	0	0	0	0	0	0	0	0	0	0	0	0	0
R/W	R/W(1)	R(0)/W(1)	R	R	R	R	R	R	R	R	R	R	R	R	R	R

Bit	Bit Name	Initial Value	R/W	Description
15	BVAL	0	R/W(1)	Buffer memory valid flag Specify 1 for this bit when writing to the FIFO buffer on the CPU side through the pipe specified in CURPIPE (current pipe) ends. 0: Invalid 1: Writing complete
14	BCLR	0	R(0)/W(1)	CPU buffer clear Specify 1 for this bit to clear the FIFO buffer on the CPU side of the current pipe. 0: Invalid 1: CPU buffer memory clear
13	FRDY	0	R	FIFO port ready This bit indicates whether the FIFO port can be accessed. 0: The FIFO port cannot be accessed. 1: The FIFO port can be accessed.
12	—	0	R	Nothing is assigned to this bit. Fix this bit to 0.
11 to 0	DTLN	All 0	R	Receive data length These bits indicate the length of receive data.

(1) Buffer memory valid flag (BVAL)

When the pipe (selected pipe) specified in the CURPIPE bits is in the sending direction, this bit must be set in the cases described below. This module switches the FIFO buffer from the CPU side to the SIE side to enable data sending.

- (1) To send short packets, set this bit when data writing ends.
- (2) To send zero length packets, set this bit before writing data to the FIFO buffer.
- (3) Set this bit after writing, to the pipe in continuous transfer mode, the data of which the size is a positive integral multiple of the maximum packet size and less than the buffer size.

When the maximum packet size of data is written to the pipe in non-continuous transfer mode, this module sets this bit to switch the FIFO buffer from the CPU side to the SIE side and enable data sending.

When this bit and the BCLR bit are set at the same time when the specified pipe is in the sending direction, this module clears the data that has been written so far and enables zero-length packets to be sent.

Setting this bit must be done only when the FRDY bit in the corresponding port control register is 1. If you want to check the value of the FRDY bit after setting this bit, wait at least 80 ns after setting this bit, and then reference the FRDY bit. Do not set this bit when the specified pipe is in the receiving direction.

(2) CPU buffer clear (BCLR) bit

When this bit is set, this module clears the FIFO buffer on the CPU side among the FIFO buffers allocated to the specified pipe.

Even if the two FIFO buffers in a double-buffer configuration are allocated to the specified pipe and the both buffers can be read, this module clears only one of the two buffers.

If this bit is set when the specified pipe is the DCP, this module clears the FIFO buffer regardless of whether the FIFO buffer is on the CPU side or it is on the SIE side. To clear the buffer on the SIE side, set this bit always after setting the PID bits for DCP to “NAK”.

When the specified pipe is other than the DCP, setting this bit must be done only when the FRDY bit in the corresponding port control register is 1. If you want to check the value of the FRDY bit after setting this bit, wait at least 80 ns after setting this bit, and then reference the FRDY bit.

(3) FIFO port ready (FRDY) bit

This bit indicates whether the FIFO port can be accessed from the CPU. This bit is operated by this module.

In the cases described below, even when this module sets this bit, data cannot be read from the FIFO port because the FIFO buffer does not contain data to be read. In these cases, set the BCLR bit to clear the FIFO buffer to enable the next sending and receiving of data.

- (1) A zero-length packet has been received while the FIFO buffer allocated to the specified pipe is empty.
- (2) A short packet has been received and data reading has ended while the BFRE bit is 1.

(4) Receive data length (DTLN) bits

These bits indicate the length of receive data. These bits are operated by this module. During reading of the FIFO buffer, the value of these bits varies depending on the value of the RCNT bit as described below.

- (1) When the RCNT bit is 0:
This module indicates a receive data length by using these bits until the CPU ends reading all received data from one FIFO buffer.
When the BFRE bit is 1, this module retains the receive data length until the BCLR bit is set even if reading of received data has ended.
- (2) When the RCNT bit is 1:
This module decrements the value of these bits each time the CPU reads data.
(The value is decremented by 1 when the MBW bits are 00, by 2 when the MBW bits are 01 or by 4 when the MBW bits are 10.)

When the CPU ends reading from one FIFO buffer, this module clears these bits. If reading of one of the FIFO buffers in a double-buffer configuration, however, ends before reading of received data from the other FIFO buffer ends, these bits indicate the receive data length for the other FIFO buffer at the end of reading from the FIFO buffer of which reading ends earlier.

When these bits are read during reading of the FIFO buffer when the RCNT bit is 1, this module updates the value of these bits within 150 ns after a cycle of read access to the corresponding FIFO port.

32B.2.8 Interrupt Enable Registers (INTENBx, BRDYENB, NRDYENB, BEMPENB)

32B.2.8.1 Interrupt Enable Register 0 [INTENB0] <Address: H'030>

Bit	15	14	13	12	11	10	9	8	7	6	5	4	3	2	1	0
	VBSE	RSME	SOFE	DVSE	CTRE	BEMPE	NRDYE	BRDYE	—	—	—	—	—	—	—	—
Initial Value	0	0	0	0	0	0	0	0	0	0	0	0	0	0	0	0
R/W	R/W	R/W	R/W	R/W	R/W	R/W	R/W	R/W	R	R	R	R	R	R	R	R

Bit	Bit Name	Initial Value	R/W	Description
15	VBSE	0	R/W	VBUS Interrupt Enable This bit prohibits or enables a USB interrupt when a VBINT interrupt is detected. 0: Interrupt output prohibited 1: Interrupt output enabled
14	RSME	0	R/W	Frame number update interrupt enable Resume interrupt enable This bit prohibits or enables a USB interrupt when a RESM interrupt is detected. 0: Interrupt output prohibited 1: Interrupt output enabled
13	SOFE	0	R/W	This bit prohibits or enables a USB interrupt when a SOF interrupt is detected. 0: Interrupt output prohibited 1: Interrupt output enabled
12	DVSE	0	R/W	Device state transition interrupt enable This bit prohibits or enables a USB interrupt when a DVST interrupt is detected. 0: Interrupt output prohibited 1: Interrupt output enabled
11	CTRE	0	R/W	Control transfer stage transition interrupt enable This bit prohibits or enables a USB interrupt when a CTRT interrupt is detected. 0: Interrupt output prohibited 1: Interrupt output enabled
10	BEMPE	0	R/W	Buffer empty interrupt enable This bit prohibits or enables a USB interrupt when a BEMP interrupt is detected. 0: Interrupt output prohibited 1: Interrupt output enabled
9	NRDYE	0	R/W	Buffer not ready response interrupt enable This bit prohibits or enables a USB interrupt when an NRDY interrupt is detected. 0: Interrupt output prohibited 1: Interrupt output enabled
8	BRDYE	0	R/W	Buffer ready interrupt enable This bit prohibits or enables a USB interrupt when a BRDY interrupt is detected. 0: Interrupt output prohibited 1: Interrupt output enabled
7 to 0	—	All 0	R	Nothing is assigned to these bits. Fix these bits to 0.

32B.2.8.2 BRDY Interrupt Enable Register [BRDYENB] <Address: H'036>

Bit	15	14	13	12	11	10	9	8	7	6	5	4	3	2	1	0
	—						PIPEBRDYE									
Initial Value	0	0	0	0	0	0	0	0	0	0	0	0	0	0	0	0
R/W	R/W	R/W	R/W	R/W	R/W	R/W	R/W	R/W	R/W	R/W	R/W	R/W	R/W	R/W	R/W	R/W

Bit	Bit Name	Initial Value	R/W	Description
15 to 10	—	All 0	R/W	Reserved When read, the initial value is read. When writing, be sure to write the initial value. Operation is not guaranteed if a value other than the initial value is written.
9 to 0	PIPEBRDYE	All 0	R/W	Pipe BRDY interrupt enable These bits prohibit or enable the BRDY bit to be set when a BRDY interrupt to a pipe is detected. 0: Interrupt output prohibited 1: Interrupt output enabled

(1) Pipe BRDY interrupt enable (PIPEBRDYE) bits

When this module detects a BRDY interrupt to the pipe for which is set 1 in this register, this module sets the corresponding PIPEBRDY bit in the BRDYSTS register, sets the BRDY bit in the INTSTS0 register, and asserts the interrupt.

When at least one of the PIPEBRDY bits in the BRDYSTS register is 1 and software changes the corresponding interrupts enable bit in this register changes from 0 to 1, this module asserts the interrupt.

32B.2.8.3 NRDY Interrupt Enable Register [NRDYENB] <Address: H'038>

Bit	15	14	13	12	11	10	9	8	7	6	5	4	3	2	1	0
	—						PIPENRDYE									
Initial Value	0	0	0	0	0	0	0	0	0	0	0	0	0	0	0	0
R/W	R/W	R/W	R/W	R/W	R/W	R/W	R/W	R/W	R/W	R/W	R/W	R/W	R/W	R/W	R/W	R/W

Bit	Bit Name	Initial Value	R/W	Description
15 to 10	—	All 0	R/W	Reserved When read, the initial value is read. When writing, be sure to write the initial value. Operation is not guaranteed if a value other than the initial value is written.
9 to 0	PIPENRDYE	All 0	R/W	Pipe NRDY interrupt enable These bits prohibit or enable the NRDY bit to be set when a BRDY interrupt to a pipe is detected. 0: Interrupt output prohibited 1: Interrupt output enabled

(1) Pipe NRDY interrupt enable (PIPENRDYE) bits

When this module detects a BRDY interrupt to the pipe for which is set 1 in this register, this module sets the corresponding PIPENRDY bit in the NRDYSTS register, sets the NRDY bit in the INTSTS0 register, and asserts the interrupt.

When at least one of the PIPENRDY bits in the NRDYSTS register is 1 and the corresponding interrupts enable bit in this register changes from 0 to 1, this module asserts the interrupt.

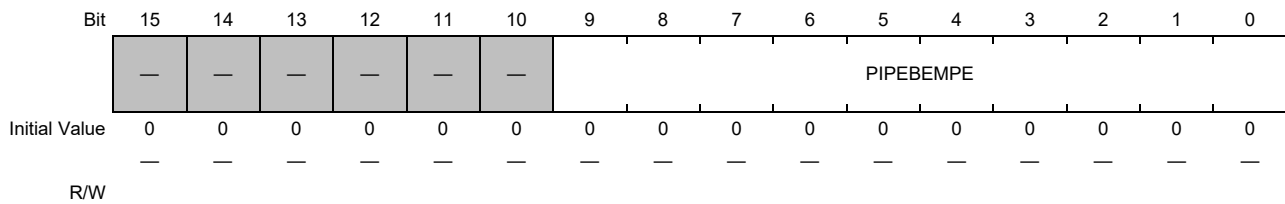
32B.2.8.4 BEMP Interrupt Enable Register [BEMPENB] <Address: H'03A>

Bit	Bit Name	Initial Value	R/W	Description
15 to 10	—	All 0	R/W	Reserved When read, the initial value is read. When writing, be sure to write the initial value. Operation is not guaranteed if a value other than the initial value is written.
9 to 0	PIPEBEMPE	All 0	R/W	Pipe BEMP interrupt enable These bits prohibit or enable the BEMP bit to be set when a BRDY interrupt to a pipe is detected 0: Interrupt output prohibited 1: Interrupt output enabled

Note: Bit numbers correspond to pipe numbers.

(1) Pipe BEMP interrupt enable (PIPEBEMPE) bits

When this module detects a BEMP interrupt to the pipe for which is set 1 in this register, this module sets the corresponding PIPEBEMPE bit in the BEMPSTS register, sets the BEMP bit in the INTSTS0 register, and asserts the interrupt.

When at least one of the PIPEBEMPE bits in the BEMPSTS register is 1 and the corresponding interrupts enable bit in this register changes from 0 to 1, this module asserts the interrupt.

32B.2.9 SOF Control Register

32B.2.9.1 SOF Pin Configuration Register [SOFCFG] <Address: H'03C>

Bit	15	14	13	12	11	10	9	8	7	6	5	4	3	2	1	0
	—	—	—	—	—	—	—	—	—	BRDYM	—	—	SOFM		—	—
Initial Value	0	0	0	0	0	0	0	0	0	0	0	0	0	0	0	0
R/W	R	R	R	R	R	R	R	R	R	R/W	R	R	R/W	R/W	R	R

Bit	Bit Name	Initial Value	R/W	Description
15 to 7	—	All 0	R	Nothing is assigned to these bits. Fix these bits to 0.
6	BRDYM	0	R/W	PIPEBRDY interrupt status clear timing This bit specifies the timing at which the PIPEBRDY interrupt is to be cleared. 0: Software clears the status. 1: Hardware clears the status by reading from or writing to the FIFO buffer. This bit can be set only during initialization (before communication). The setting cannot be changed after communication.
5, 4	—	All 0	R	Nothing is assigned to these bits. Fix these bits to 0.
3, 2	SOFM	All 0	R/W	SOF function setting These bits are used to select SOF pulse output mode. 00: SOF output disabled 01: SOF output in units of 1 ms 10: μ SOF output in units of 125 μ s 11: Reserved
1, 0	—	All 0	R	Nothing is assigned to these bits. Fix these bits to 0.

32B.2.10 Interrupt Status

32B.2.10.1 Interrupt Status Register 0 [INTSTS0] <Address: H'040>

Bit	15	14	13	12	11	10	9	8	7	6	5	4	3	2	1	0
	VBINT	RESM	SOFR	DVST	CTR	BEMP	NRDY	BRDY	VBSTS	DVSQ		VALID	CTSQ			
Initial Value	0	0	0	0	0	0	0	0	—	0	0	0	0	0	0	0
	—	—	—	1	—	—	—	—	—	0	0	1	—	—	—	—
R/W	R/W(0)	R/W(0)	R/W(0)	R/W(0)	R/W(0)	R	R	R	R	R	R	R	R/W(0)	R	R	R

Bit	Bit Name	Initial Value	R/W	Description
15	VBINT	0	R/W(0)	Change detection interrupt status This bit indicates the VBUS change detection interrupt status. 0: No VBUS interrupt is generated. 1: A VBUS interrupt is generated.
14	RESM	0	R/W(0)	Resume interrupt status This bit indicates the resume detection interrupt status. 0: No resume interrupt is generated. 1: A resume interrupt is generated.
13	SOFR	0	R/W(0)	Frame number update interrupt status This bit indicates the frame number update interrupt status. 0: No SOF interrupt is generated. 1: A SOF interrupt is generated.
12	DVST	0	R/W(0)	Device state transition interrupt status This bit indicates the device state transition interrupt. 0: No device state transition interrupt is generated. 1: A device state transition interrupt is generated.
11	CTR	0	R/W(0)	Control transfer stage transition interrupt status This bit indicates the status of a control transfer stage transition interrupt. 0: No control transfer stage transition interrupt is generated. 1: A control transfer stage transition interrupt is generated.
10	BEMP	0	R	BEMP interrupt status This bit indicates the BEMP interrupt status. 0: No BEMP interrupt is generated. 1: A BEMP interrupt is generated.
9	NRDY	0	R	NRDY interrupt status This bit indicates the NRDY interrupt status. 0: No NRDY interrupt is generated. 1: An NRDY interrupt is generated.
8	BRDY	0	R	BRDY interrupt status This bit indicates the BRDY interrupt status. 0: No BRDY interrupt is generated. 1: A BRDY interrupt is generated.
7	VBSTS	0	R	VBUS input status This bit indicates the VBUS pin input status. 0: The VBUS pin is at the low level. 1: The VBUS pin is at the high level.

Bit	Bit Name	Initial Value	R/W	Description
6 to 4	DVSQ	All 0	R	Device state These bits indicate the device state. 000: Powered state 001: Default state 010: Address state 011: Configured state 1xx: Suspended state
3	VALID	0	R/ W(0)	USB request reception This bit indicates whether USB request reception is detected. 0: Not detected 1: A setup packet is received.
2 to 0	CTSQ	All 0	R	Control transfer stage These bits indicate the control transfer stage. 000: Idle or setup stage 001: Control reading data stage 010: Control reading status stage 011: Control writing data stage 100: Control writing status stage 101: Control writing (No Data) status stage 110: Control transfer sequence error 111: Reserved

Note: When you want to clear the status indicated by the VBINT, RESM, SOFR, DVST, or CTRT bit, write 0 to only the bit to be cleared and 1 to other bits. Do not write 0 to any status bit that is currently 0.

Note: This module detects a status change indicated by the VBINT or RESM bit in this register even while the clock is stopped (the SUSPM bit is 0), and reports an interrupt corresponding to the status bit if the interrupt is enabled. Clearing the interrupt status must be done after the clock enabled.

(1) VBUS change interrupt status (VBINT) bit

This module sets this bit when it detects a change of the level of the VBUS pin input (from the high level to low level, or vice versa). This module indicates the level of the VBUS pin input by the VBSTS bit. When a VBINT interrupt occurs, read the VBSTS bit several times to check for consistency and remove chattering.

(2) Resume interrupt status (RESM) bit

This module sets this bit when it is in the suspended state (DVSQ bits are 1XX) and detects a falling edge of the signal at the DP pin.

(3) Frame number update interrupt status (SOFR) bit

This module sets this bit under the following conditions:

This module sets this bit when the frame number is updated. (The frame number update interrupt is monitored at intervals of 1 ms.)

This module detects an SOFR interrupt based on SOF interpolation even when an SOF packet from the USB host is damaged.

(4) Device state transition interrupt status (DVST) bit

When this module detects a change of the device state, this module updates the value of the DVSQ bits, and sets this bit. When a device state transition interrupt occurs, clear the interrupt status before this module detects the next device state transition.

(5) Control transfer stage transition interrupt status (CTRT) bit

When this module detects a transition of control transfer stage, this module updates the value of the CTSQ bits and sets this bit.

When a control transfer stage transition interrupt occurs, clear the interrupt status before this module detects the next transition of control transfer stage.

(6) Buffer empty interrupt status (BEMP) bit

This module sets this bit when at least one of the PIPEBEMP bits in the BEMPSTS register corresponding to the pipes for which the PIPEBEMPE bit in the BEMPENB register is set (that is, when this module detects a BEMP interrupt to at least one of the pipes for which is enabled BEMP interrupt notification).

For the conditions to assert the PIPEBEMP status signal, see the description of the BEMPSTS register.

This module clears this bit when writes 0 to all the PIPEBEMP bits corresponding to the pipes for which a BEMP interrupt has been enabled by setting the PIPEBEMPE bit.

Cannot clear this bit even by writing 0.

(7) Buffer not-ready interrupt status (NRDY) bit

This module sets this bit when at least one of the PIPENRDY bits in the BNRDYSTS register corresponding to the pipes for which the PIPENRDYE bit in the NRDYENB register is set (that is, when this module detects an NRDY interrupt to at least one of the pipes for which is enabled NRDY interrupt notification).

For the conditions to assert the PIPENRDY status signal, see the description of the NRDYSTS register.

This module clears this bit when writes 0 to all the PIPENRDY bits corresponding to the pipes for which a NRDY interrupt has been enabled by setting the PIPENRDYE bit.

Software cannot clear this bit even by writing 0.

(8) Buffer ready interrupt status (BRDY) bit

This module sets this bit when at least one of the PIPEBRDY bits in the BRDYSTS register corresponding to the pipes for which the PIPEBRDYE bit in the BRDYENB register is set (that is, when this module detects an BRDY interrupt to at least one of the pipes for which is enabled BRDY interrupt notification).

For the conditions to assert the PIPEBRDY status signal, see the description of the BRDYSTS register.

This module clears this bit when writes 0 to all the PIPEBRDY bits corresponding to the pipes for which a BRDY interrupt has been enabled by setting the PIPEBRDYE bit.

Software cannot clear this bit even by writing 0.

32B.2.10.2 BRDY Interrupt Status Register [BRDYSTS] <Address: H'046>

Bit	15	14	13	12	11	10	9	8	7	6	5	4	3	2	1	0
	—						PIPEBRDY									
Initial Value	0	0	0	0	0	0	0	0	0	0	0	0	0	0	0	0
R/W	R/W	R/W	R/W	R/W	R/W	R/W	R/W(0)	R/W(0)	R/W(0)	R/W(0)	R/W(0)	R/W(0)	R/W(0)	R/W(0)	R/W(0)	R/W(0)

Bit	Bit Name	Initial Value	R/W	Description
15 to 10	—	All 0	R/W	Reserved When read, the initial value is read. When writing, be sure to write the initial value. Operation is not guaranteed if a value other than the initial value is written.
9 to 0	PIPEBRDY	All 0	R/W(0)	Pipe BRDY interrupt status These bits indicate the BRDY interrupt status of each pipe. 0: No interrupt is generated. 1: An interrupt is generated.

Note: Bit numbers correspond to pipe numbers.

Note: To clear the interrupt status indicated by a bit in this register when the BRDYM bit is 0, write 0 to only the bit to be cleared and 1 to other bit.

Note: When the BRDYM bit is 0, clearing the BRDY interrupt status must be done always before the next access to the FIFO.

(1) Pipe BRDY interrupt status (PIPEBRDY) bit

When this module detects a BRDY interrupt to a pipe, this module sets the corresponding PIPEBRDY bit in the BRDYSTS register. At that time, if already set the corresponding bit in the BRDYENB register, this module sets the BRDY bit in the INTSTS0 register, and asserts the interrupt.

Conditions to generate and clear a BRDY interrupt vary depending on the values of the BRDYM bit, and the BFRE bit for each pipe.

(a) BRDYM = 0 and BFRE = 0

When the BRDYM and BFRE bits are 0, the BRDY interrupt is generated to indicate that the FIFO port has become ready for access.

Under the conditions described below, this module generates an internal BRDY interrupt request trigger, and sets the PIPEBRDY bit corresponding to the pipe for which the request trigger is generated.

1. For the pipe in the sending direction
 - (a) When the DIR bit changes from 0 to 1
 - (b) When this module has ended sending packets through a pipe when data writing by the CPU to the FIFO buffer allocated to that pipe is disabled (when the value read from the BSTS bit is 0)
In continuous transfer mode, a request trigger is generated when data has all been sent from one FIFO buffer.
 - (c) When, in a double-buffer configuration, one FIFO buffer is empty when writing to the other FIFO buffer has ended
If sending to one FIFO buffer has ended during writing to the other FIFO buffer, no request trigger is generated until the ongoing writing to the other FIFO buffer ends.
 - (d) When this module flushes the FIFO buffer allocated to the pipe of which the transfer type is isochronous.

- (e) When the state of the FIFO buffer is changed from the write-disabled state to the write-enabled state by writing 1 to the ACLRM bit

No request trigger is generated when the pipe is the DCP (in other words, when data is sent by a control transfer).

2. For the pipe in the receiving direction

- (a) When this module has ended receiving packets through a pipe and reading from the FIFO buffer is enabled when data reading by the CPU from the FIFO buffer allocated to that pipe is disabled (when the value read from the BSTS bit is 0)

No request trigger is generated for the transaction that involves a data PID mismatch.

In continuous transmission/reception mode, no request trigger is generated when the data size is the maximum packet size and the FIFO buffer still has a free space.

If a short packet is received, a request trigger is generated even when the FIFO buffer has a free space.

When the transaction counter is used, a request trigger is generated when the specified number of packets have been received.

In that case, the request trigger is generated even if the FIFO buffer has a free space.

- (b) When, in a double-buffer configuration, one FIFO buffer is in the read-enabled state when reading from the other FIFO buffer has ended

If receiving from one FIFO buffer has ended during reading from the other FIFO buffer, no request trigger is generated until the ongoing reading from the other FIFO buffer ends.

This interrupt does not occur during the communication at the status stage of a control transfer.

The PIPEBRDY interrupt status of the corresponding pipe can be cleared to "0" by writing "0" to the corresponding bit. When clearing a PIPEBRDY bit by writing 0, write 1 to all the PIPEBRDY bits corresponding to other pipes.

Clearing the pipe BRDT interrupt status must be done always before the next access to the FIFO buffer.

(b) When BRDYM = 0 and BFRE = 1

When the BRDYM bit is 0 and the BFRE bit is 1, this module determines that a BRDY interrupt occurs when all the data for a transfer has been read through a receiving pipe, and sets the PIPEBRDY bit corresponding to the pipe.

This module determines that the last data in a transfer has been received when one of the following conditions is met:

1. A short packet or a zero-length packet has been received.
2. The transaction counter (TRNCNT bits) is used, and as many packets as the value of the TRNCNT bits have been received.

When one of the above conditions is met and reading of the relevant data has ended, this module determines that all the data in a transfer has been read.

If a zero-length packet is received when the FIFO buffer is empty, this module determines that all the data in a transfer has been read when the FRDY bit is set and the DTLN bits are cleared in the corresponding FIFO Port Control Register. To start the next transfer in that case, write 1 to the BCLR bit in the corresponding FIFOCTR.

When the BRDYM bit is 0 and the BFRE bit is 1, this module does not detect any BRDY interrupt to the pipe in the sending direction.

The PIPEBRDY interrupt status of the corresponding pipe can be cleared to “0” by writing “0” to the corresponding bit. When clearing a PIPEBRDY bit by writing 0, write 1 to the PIPEBRDY bits corresponding to other pipes.

In this mode, do not change the value of the BFRE bit until all the processing for a transfer ends.

If you need to change the value of the BFRE bit during the transfer, set the ACLRM bit to clear all the FIFO buffers for the specified pipe.

(c) When BRDYM = 1 and BFRE = 0

When the BRDYM bit is 1 and the BFRE bit is 0, the values of individual PIPEBRDY bits interlock with the values of the BSTS bits for individual pipes. In other words, this module sets or clears the BRDY interrupt status of a pipe according to the state of the FIFO buffer allocated to the pipe.

(a) For the pipe in the sending direction

This module sets the PIPEBRDY bit for the pipe when data can be written to the FIFO port or clears the PIPEBRDY bit when data cannot be written to the FIFO port.

The BRDY interrupt signal, however, is not asserted even when the sending pipe is write-enabled if the pipe is the DCP.

(b) For the pipe in the receiving direction

This module sets the PIPEBRDY bit for the pipe when data can be read from the FIFO port or clears the PIPEBRDY bit when all data has been read (that is, when data reading from the FIFO port is disabled).

If a zero-length packet is received when the FIFO buffer is empty, the PIPEBRDY bit corresponding to the specified pipe is kept being set and the BRDY interrupt signal is kept being asserted until sets the BCLR bit.

When the BRDYM bit is 1 and the BFRE bit is 0, this module cannot clear any PIPEBRDY bit.

When the BRDYM bit is 1, all the BFRE bits (for all pipes) must be 0.

32B.2.10.3 NRDY Interrupt Status Register [NRDYSTS] <Address: H'048>

Bit	15	14	13	12	11	10	9	8	7	6	5	4	3	2	1	0
	—						PIPENRDY									
Initial Value	0	0	0	0	0	0	0	0	0	0	0	0	0	0	0	0
R/W	R/W	R/W	R/W	R/W	R/W	R/W	R/W(0)	R/W(0)	R/W(0)	R/W(0)	R/W(0)	R/W(0)	R/W(0)	R/W(0)	R/W(0)	R/W(0)

Bit	Bit Name	Initial Value	R/W	Description
15 to 10	—	All 0	R/W	Reserved When read, the initial value is read. When writing, be sure to write the initial value. Operation is not guaranteed if a value other than the initial value is written.
9 to 0	PIPENRDY	All 0	R/W(0)	Pipe NRDY interrupt status These bits indicate the NRDY interrupt status of each pipe. 0: No interrupt is generated. 1: An interrupt is generated.

Note: Bit numbers correspond to pipe numbers.

Note: To clear the interrupt status indicated by a bit in this register, write 0 only to the bit and 1 to all other bit.

(1) Pipe NRDY interrupt status (PIPENRDY) bit

When this module issues an internal NRDY interrupt request for a pipe of which the PID is set to BUF, this module sets the PIPENRDY bit corresponding to the pipe in the NRDYSTS register. At that time, if the NRDYENB register bit corresponding to the pipe is set, this module sets the NRDY bit in the INTSTS0 register, and asserts the interrupt.

This module issues an internal NRDY interrupt request for individual pipes under the conditions described below. This module does not issue any interrupt request at the status stage of a control transfer.

(a) For the pipe in the sending direction

- (1) When an IN token is received in a situation where the PID bits corresponding to the specified pipe are 01 (BUF) and the FIFO buffer does not contain send data
When an IN token is received, this module issues an NRDY interrupt request, and sets the PIPENRDY bit.
If the transfer type of the pipe for which the interrupt is generated is isochronous transfer, this module sends a zero-length packet, and sets the OVRN bit.

(b) For the pipe in the receiving direction

- (1) When an OUT token is received in a situation where the PID bits corresponding to the specified pipe are 01 (BUF) and the FIFO buffer is full
If the transfer type of the pipe for which the interrupt is generated is isochronous transfer, this module issues an NRDY interrupt request, sets the PIPENRDY bit, and sets the OVRN bit.
If the transfer type of the pipe for which the interrupt is generated is not isochronous transfer, this module issues an NRDY interrupt request when sending a NAK Handshake signal after receiving the data that follows the OUT token, and sets the PIPENRDY bit.
Note, however, that this module does not issue an NRDY interrupt request when resending data (when a DATA-PID mismatch has occurred).
This module does not issue an NRDY interrupt request also when an error has occurred in a data packet.

- (2) When a PING token is received in a situation where the PID bits corresponding to the specified pipe are 01 (BUF) and the FIFO buffer is full
When a PING token is received, this module issues an NRDY interrupt request, and sets the PIPENRDY bit.
- (3) When the transfer type of the specified pipe is isochronous transfer, the PID bits corresponding to the specified pipe are 01 (BUF), and data has not been received normally within an interval frame
When an SOF token is received, this module issues an NRDY interrupt request, and sets the PIPENRDY bit for the specified pipe.

32B.2.10.4 BEMP Interrupt Status Register [BEMPSTS] <Address: H'04A>

Bit	15	14	13	12	11	10	9	8	7	6	5	4	3	2	1	0
	—						PIPEBEMP									
Initial Value	0	0	0	0	0	0	0	0	0	0	0	0	0	0	0	0
R/W	R/W	R/W	R/W	R/W	R/W	R/W	R/W(0)	R/W(0)	R/W(0)	R/W(0)	R/W(0)	R/W(0)	R/W(0)	R/W(0)	R/W(0)	R/W(0)

Bit	Bit Name	Initial Value	R/W	Description
15 to 10	—	All 0	R/W	Reserved When read, the initial value is read. When writing, be sure to write the initial value. Operation is not guaranteed if a value other than the initial value is written.
9 to 0	PIPEBEMP	All 0	R/W(0)	Pipe BEMP interrupt status These bits indicate the BEMP interrupt status of each pipe. 0: No interrupt is generated. 1: An interrupt is generated.

Note: Bit numbers correspond to pipe numbers.

Note: To clear the interrupt status indicated by a bit in this register, write 0 only to the bit and 1 to all other bit.

(1) Pipe BEMP interrupt status (PIPEBEMP) bit

When this module detects a BEMP interrupt to a pipe of which the PID is set to BUF, this module sets the PIPEBEMP bit corresponding to the pipe in the BEMPSTS register. At that time, if the BEMPENB register bit corresponding to the pipe is set, this module sets the BEMP bit in the INTSTS0 register, and asserts the interrupt.

This module issues an internal BEMP interrupt request for individual pipes under the conditions described below.

1. When data sending (including sending of zero-length packets) to a pipe in the sending direction has ended and the FIFO buffer allocated to the pipe is empty
In a single-buffer configuration, this module generates a BRDY interrupt at the same time as issuing an internal BEMP interrupt request for the pipes other than the DCP.
Note, however, that this module does not issue the internal BEMP interrupt request in the following cases:
 - (a) When software (DMAC) has already started writing to the CPU-side FIFO buffer, in a double-buffer configuration, when sending data for one buffer ends
 - (b) When the buffer is cleared (to empty the buffer) by writing 1 to the ACLRM or BCLR bit
 - (c) During an IN transfer (sending zero-length packets) at the status stage of a control transfer
2. For the pipe in the receiving direction
When the data larger than the specified maximum packet size has been received normally
In that case, this module issues a BEMP interrupt request, sets the PIPEBEMP bit for the specified pipe, discards the received data, and changes the value of the PID bits for the specified pipe to 11 (STALL).
Then, this module returns a STALL packet.
Note, however, that this module does not issue the internal BEMP interrupt request in the following cases:
 - (a) When a CRC or bit stuff error has been detected in the received data
 - (b) When a SETUP transaction is being executed

Writing 0 to this bit clears the interrupt status.

Writing 1 to this bit causes no effect.

32B.2.11 Frame Number Registers (FRMNUM, UFRMNUM)

32B.2.11.1 Frame Number Register [FRMNUM] <Address: H'04C>

Bit	15	14	13	12	11	10	9	8	7	6	5	4	3	2	1	0
	OVRN	CRCE	—	—	—	FRNM										
Initial Value	0	0	0	0	0	0	0	0	0	0	0	0	0	0	0	0
R/W	R/W(0)	R/W(0)	R	R	R	R	R	R	R	R	R	R	R	R	R	R

Bit	Bit Name	Initial Value	R/W	Description
15	OVRN	0	R/W(0)	Overrun/underrun detection status This bit indicates whether an overrun or underrun is detected in the pipe being used to perform an isochronous transfer. 0: No error 1: An error occurred.
14	CRCE	0	R/W(0)	CRC error detection status This bit indicates the CRC error detection status for the pipe being used to perform an isochronous transfer. 0: No error 1: An error occurred.
13 to 11	—	All 0	R	Nothing is assigned to these bits. Fix these bits to 0.
10 to 0	FRNM	All 0	R	Frame number These bits indicate the latest frame number.

Note: The OVRN bit is intended for debugging. When designing a system, design transfer timings appropriately to prevent buffer overruns and underruns.

(1) Overrun/underrun detection status (OVRN) bit

This module sets this bit when this module detects an overrun or underrun in a pipe of which the transfer type is isochronous transfer.

When this module detects an overrun or underrun, this module issues an internal NRDY interrupt request. For details, see **Section 32B.2.10.3(1), Pipe NRDY interrupt status (PIPENRDY) bit**.

Software can clear this bit by writing 0 to this bit. If the CRCE bit should not be cleared together when this bit is cleared, write H'40.

When the peripheral controller function is selected

This module sets this bit in the following cases:

- When an IN token is received although writing send data to the FIFO has not ended, in the case of a pipe that is in the sending direction and performs an isochronous transfer
- When an OUT token is received although the free space of FIFO buffer is less than the size of one FIFO buffer, in the case of a pipe that is in the sending direction and performs an isochronous transfer

(2) CRC error detection status (CRCE) bit

This module sets this bit when this module detects a CRC or bit stuff error in a pipe of which the transfer type is isochronous transfer.

Software can clear this bit by writing 0 to this bit. If the OVRN bit should not be cleared together when this bit is cleared, write H'80.

When this module detects a CRC error, this module issues an internal NRDY interrupt request. For details, see **Section 32B.2.10.3(1), Pipe NRDY interrupt status (PIPENRDY) bit**.

(3) Frame number (FRNM) bits

This module updates the value of these bits each time an SOF packet is received (once per 1 ms), and indicates the latest frame number in these bits.

When reading these bits, read them twice and check for consistency.

32B.2.11.2 Micro Frame Number Register [UFRMNUM] <Address: H'04E>

Bit	15	14	13	12	11	10	9	8	7	6	5	4	3	2	1	0
	—	—	—	—	—	—	—	—	—	—	—	—	—	UFRNM		
Initial Value	0	0	0	0	0	0	0	0	0	0	0	0	0	0	0	0
R/W	R	R	R	R	R	R	R	R	R	R	R	R	R	R	R	R

Bit	Bit Name	Initial Value	R/W	Description
15	—	0	R	Nothing is assigned to these bits. Fix these bits to 0.
14 to 3	—	All 0	R	Nothing is assigned to these bits. Fix these bits to 0.
2 to 0	UFRNM	All 0	R	Micro frame These bits indicate the micro frame number.

(1) Micro frame number (UFRNM) bit

In high-speed transfer mode, this module writes the micro frame number to these bits. In a mode other than high-speed transfer mode, this module writes H'00 to these bits.

When reading these bits, read them twice and check for consistency.

32B.2.12 USB Address

32B.2.12.1 USB Address Register [USBADDR] <Address: H'050>

Bit	15	14	13	12	11	10	9	8	7	6	5	4	3	2	1	0
	—	—	—	—	—	—	—	—	—	USBADDR						
Initial Value	0	0	0	0	0	0	0	0	0	0	0	0	0	0	0	0
R/W	R	R	R	R	R	R	R	R	R	R	R	R	R	R	R	R

Bit	Bit Name	Initial Value	R/W	Description
15 to 11	—	All 0	R	Nothing is assigned to these bits. Fix these bits to 0.
10 to 8	—	All 0	R	Nothing is assigned to these bits. Fix these bits to 0.
7	—	0	R	Nothing is assigned to this bit. Fix this bit to 0.
6 to 0	USBADDR	All 0	R	USB address These bits indicate the USB address allocated by the host.

(1) USB address (USBADDR) bits

When this module has received and normally processed a SetAddress request, this module writes the received USB address to these bits.

When this module detects a USB bus reset, this module writes H'00 to these bits.

32B.2.13 USB Request Registers

USB request registers are used to store control transfer setup requests.

These registers store the values set in the received USB requests.

32B.2.13.1 USB Request Type Register [USBREQ] <Address: H'054>

Bit	15	14	13	12	11	10	9	8	7	6	5	4	3	2	1	0	
	bRequest								bmRequestType								
Initial Value	0	0	0	0	0	0	0	0	0	0	0	0	0	0	0	0	0
R/W	R	R	R	R	R	R	R	R	R	R	R	R	R	R	R	R	R

Bit	Bit Name	Initial Value	R/W	Description
15 to 8	bRequest	All 0	R	Request Value of USBRequestbRequest
7 to 0	bmRequestType	All 0	R	Request type Value of USBRequestbmRequestType

(1) USB request (bRequest) bits

These bits indicate the value of the USB request data this module has received in a SETUP transaction. Writing to these bits is ignored.

(2) USB request type (bmRequestType) bits

These bits indicate the value of the USB request data this module has received in a SETUP transaction. Writing to these bits is ignored.

32B.2.13.2 USB Request Value Register [USBVAL] <Address: H'056>

Bit	15	14	13	12	11	10	9	8	7	6	5	4	3	2	1	0
	wValue															
Initial Value	0	0	0	0	0	0	0	0	0	0	0	0	0	0	0	0
	0	0	0	0	0	0	0	0	0	0	0	0	0	0	0	0
R/W	R	R	R	R	R	R	R	R	R	R	R	R	R	R	R	R

Bit	Bit Name	Initial Value	R/W	Description
15 to 0	wValue	All 0	R	Value Value of the wValue field in a USB request

(1) Value (wValue) bits

These bits indicate the value of the wValue field in a USB request.

These bits indicate the value of wValue field in the USB request data this module has received in a SETUP transaction. Writing to these bits is ignored.

32B.2.13.3 USB Request Index Register [USBINDX] <Address: H'058>

Bit	15	14	13	12	11	10	9	8	7	6	5	4	3	2	1	0
	wIndex															
Initial Value	0	0	0	0	0	0	0	0	0	0	0	0	0	0	0	0
	0	0	0	0	0	0	0	0	0	0	0	0	0	0	0	0
R/W	R	R	R	R	R	R	R	R	R	R	R	R	R	R	R	R

Bit	Bit Name	Initial Value	R/W	Description
15 to 0	wIndex	All 0	R	Index Value of the wIndex field in a USB request

(1) Index (wIndex) bits

These bits indicate the value of the wIndex field in a USB request.

These bits indicate the value of wIndex field in the USB request data this module has received in a SETUP transaction. Writing to these bits is ignored.

32B.2.13.4 USB Request Length Register [USBLENG] <Address: H'05A>

Bit	15	14	13	12	11	10	9	8	7	6	5	4	3	2	1	0
	wLength															
Initial Value	0	0	0	0	0	0	0	0	0	0	0	0	0	0	0	0
R/W	R	R	R	R	R	R	R	R	R	R	R	R	R	R	R	R

Bit	Bit Name	Initial Value	R/W	Description
15 to 0	wLength	All 0	R	Length Value of the wLength field in a USB request

(1) Length (wLength) bits

These bits indicate the value of the wLength field in a USB request.

These bits indicate the value of wLength field in the USB request data this module has received in a SETUP transaction. Writing to these bits is ignored.

32B.2.14 DCP Configuration

When performing a data communication by a control transfer, use the default control pipe (DCP).

32B.2.14.1 DCP Configuration Register [DCPCFG] <Address: H'05C>

Bit	15	14	13	12	11	10	9	8	7	6	5	4	3	2	1	0
	—	—	—	—	—	—	—	CNTMD	SHTNA K	—	—	—	—	—	—	—
Initial Value	0	0	0	0	0	0	0	0	0	0	0	0	0	0	0	0
R/W	—	—	—	—	—	—	—	R/W	R/W	—	—	—	—	—	—	—

Bit	Bit Name	Initial Value	R/W	Description
15 to 9	—	All 0		Nothing is assigned to these bits. Fix these bits to 0.
8	CNTMD	0	R/W	Continuous transfer mode This bit specifies whether to use the default control pipe to perform communication in continuous transfer mode. 0: Non-continuous transfer mode 1: Continuous transfer mode
7	SHTNAK	0	R/W	Pipe disable at transfer end When the default control pipe is in the receiving direction, this bit specifies whether to change the PID setting to NAK when the transfer ends. 0: Continues the pipe when the transfer ends 1: Disables the pipe when the transfer ends
6 to 0	—	All 0		Nothing is assigned to these bits. Fix these bits to 0.

32B.2.14.2 DCP Max. Packet Size Register [DCPMAXP] <Address: H'05E>

Bit	15	14	13	12	11	10	9	8	7	6	5	4	3	2	1	0
	—	—	—	—	—	—	—	—	—	MXPS						
Initial Value	0	0	0	0	0	0	0	0	0	1	0	0	0	0	0	0
R/W	R	R	R	R	R	R	R	R	R	R/W	R/W	R/W	R/W	R/W	R/W	R/W

Bit	Bit Name	Initial Value	R/W	Description
15 to 7	—	All 0	R	Nothing is assigned to these bits. Fix these bits to 0.
6 to 0	MXPS	H'40	R/W	Maximum packet size These bits specify the maximum data payload size (maximum packet size) for the DCP.

(1) Maximum packet size (MXPS) bits

These bits are used to specify the maximum data payload size (maximum packet size) for the DCP.

The default is H'40 (64 bytes).

The value of the MXPS bits must conform to the USB Specification.

Writing a value to the MXPS bits must be done when the PID is set to NAK and no value is set in the CURPIPE bits. If you need to change the value of these bits after changing the PID setting for the specified pipe from BUF to NAK, check the PBUSY bit is 0 before changing the value of these bits. If, however, this module has changed the PID setting from BUF to NAK, the value of the PBUSY bit need not be checked.

When the MXPS bits are all 0, data must not be written to the FIFO buffer, and the PID setting must not be changed to BUF.

32B.2.14.3 DCP Control Register [DCPCTR] <Address: H'060>

Bit	15	14	13	12	11	10	9	8	7	6	5	4	3	2	1	0
	BSTS	—	—	—	—	—	—	SQCLR	SQSET	SQMON	PBUSY	—	—	CCPL	PID	
Initial Value	0	0	0	0	0	0	0	0	0	1	0	0	0	0	0	0
R/W	R	R	R	R	R	R	R	R(0)/W(1)	R(0)/W(1)	R	R	R	R	R/W	R/W	R/W

Bit	Bit Name	Initial Value	R/W	Description
15	BSTS	0	R	Buffer status This bit indicates the accessibility status of the DCP FIFO buffer. 0: Buffer access is not possible. 1: Buffer access is possible.
14 to 9	—	All 0	R	Nothing is assigned to these bits. Fix these bits to 0.
8	SQCLR	0	R(0)/W(1)	Toggle bit clear This bit can set DATA0 as the expected value of the sequence toggle bit for the next transaction in DCP transfer. 0: Writing disabled 1: DATA0 specified
7	SQSET	0	R(0)/W(1)	Toggle bit set This bit can set DATA1 as the expected value of the sequence toggle bit for the next transaction in DCP transfer. 0: Writing disabled 1: DATA1 specified
6	SQMON	0	R	Sequence toggle bit monitor This bit indicates the expected value of the sequence toggle bit for the next transaction in DCP transfer. 0: DATA0 1: DATA1
5	PBUSY	0	R	Pipe busy This bit indicates whether the specified pipe is being used in the USB bus. 0: The specified pipe is not used in the USB bus. 1: The specified pipe is being used in the USB bus.
4 to 3	—	All 0	R	Nothing is assigned to these bits. Fix these bits to 0.
2	CCPL	0	R/W	Control transfer end enable Setting this bit permits the status stage of the control transfer to end. 0: Does not permit the control transfer to end. 1: Permits the control transfer to end.
1, 0	PID	All 0	R/W	Response PID These bits control responses from this module in control transfer. 00: NAK response 01: BUF response (according to the buffer status) 10: STALL response 11: STALL response

(1) Buffer status (BSTS) bit

This bit indicates whether the CPU can access the FIFO buffer allocated to the DCP. This bit is operated by this module. The meaning of this bit varies as follows depending on the value of the ISEL bit:

1. When ISEL = 0: This bit indicates whether receive data can be read from the FIFO buffer.
2. When ISEL = 1: This bit indicates whether send data can be written to the FIFO buffer.

(2) Sequence toggle bit clear (SQCLR) bit

When software sets this bit, this module specifies DATA0 as the expected value of the sequence toggle bit for the specified pipe. This module always clears this bit.

Do not set the SQCLR and SQSET bits at the same time.

Setting this bit must be done when the PID is set to NAK and no value is set in the CURPIPE bits.

If you need to set this bit after changing the PID setting for the specified pipe from BUF to NAK, check, that the PBUSY bit is 0 before setting this bit. If, however, this module has changed the PID setting from BUF to NAK, the value of the PBUSY bit need not be checked.

(3) Sequence toggle bit set (SQSET) bit

When software sets this bit, this module specifies DATA1 as the expected value of the sequence toggle bit for the specified pipe. This module always clears this bit.

Do not set the SQCLR and SQSET bits at the same time.

Setting this bit must be done when the PID is set to NAK and no value is set in the CURPIPE bits.

If you need to set this bit after changing the PID setting for the specified pipe from BUF to NAK, check, that the PBUSY bit is 0 before setting this bit. If, however, this module has changed the PID setting from BUF to NAK, the value of the PBUSY bit need not be checked.

(4) Sequence toggle bit monitor (SQMON) bit

This bit indicates the expected value of the sequence toggle bit for the specified pipe. This bit is operated by this module. When a transaction ends normally, this module toggles this bit.

This module, however, does not toggle this bit if a DATA-PID mismatch occurs during a transfer in the receiving direction.

When a SETUP packet is received normally, this module sets this bit (to specify DATA1 as the expected value).

This module does not reference this bit in an IN or OUT transaction at the status stage. Also, this module does not toggle this bit even when the transaction ends normally.

(5) Pipe busy (PBUSY) bit

This module changes this bit from 0 to 1 when a USB transaction using the specified pipe starts. This module changes this bit from 1 to 0 when the transaction ends.

Reading this bit after software sets the PID to NAK enables you to check whether you can change pipe settings.

(6) Control transfer end enable (CCPL) bit

When software sets this bit when the PID of the specified pipe is BUF, this module ends the status stage of the ongoing control transfer.

In other words, in a control read transfer, this module sends an ACK handshake in response to an OUT transaction request from the USB host, and, in a control write or no-data control transfer, this module sends a zero-length packet in response to an IN transaction request from the USB host. If, however, a SetAddress request is detected, this module performs automatic response throughout the period from the setup stage to the end of the status stage regardless of the value of this bit.

When a new SETUP packet is received, this module changes this bit from 1 to 0.

When the VALID bit is 1, software cannot set this bit.

(7) Response PID (PID) bits

The setting of these bits must be changed from NAK to BUF when the data stage or status stage of a control transfer is executed.

This module changes the value of these bits in the following cases:

1. This module changes the value of these bits to 00 (NAK) when it receives a SETUP packet. At that time this module sets the VALID bit. Software cannot change the value of these bits until it clears the VALID bit.
2. When set these bits to 01 (BUF), this module changes the value of these bits to 11 (STALL) when it receives the data exceeding the specified maximum packet size.
3. This module changes the value of these bits to 1x (STALL) when it detects a sequence error in a control transfer.
4. This module changes the value of these bits to 00 (NAK) when it detects a USB reset.

This module does not reference these bits during SetAddress request processing (automatic processing).

32B.2.15 Pipe Configuration Registers (PIPESEL, PIPECFG, PIPEBUF, PIPEMAXP, PIPEPERI)

To configure pipes 1 to 15, use the PIPESEL, PIPECFG, PIPEBUF, PIPEMAXP, PIPEPERI, PIPExCTR, PIPExTRE, and PIPExTRN registers.

Select the pipes to be used by using the PIPESEL register, and then configure functions of individual pipes by using the PIPECFG, PIPEBUF, PIPEMAXP, and PIPEPERI registers. Note that you can use the PIPExCTR, PIPExTRE, and PIPExTRN registers for setting regardless of the pipe selection by the PIPESEL register.

32B.2.15.1 Pipe Window Select Register [PIPESEL] <Address: H'064>

Bit	15	14	13	12	11	10	9	8	7	6	5	4	3	2	1	0
	—	—	—	—	—	—	—	—	—	—	—	—	PIPESEL			
Initial Value	0	0	0	0	0	0	0	0	0	0	0	0	0	0	0	0
R/W	R	R	R	R	R	R	R	R	R	R	R	R	R/W	R/W	R/W	R/W

Bit	Bit Name	Initial Value	R/W	Description
15 to 4	—	All 0	R	Nothing is assigned to these bits. Fix these bits to 0.
3 to 0	PIPESEL	All 0	R/W	Pipe window select These bits specify a pipe for registers at addresses H'68 to H'6E. 0000: No selection 0001: PIPE1 0010: PIPE2 0011: PIPE3 0100: PIPE4 0101: PIPE5 0110: PIPE6 0111: PIPE7 1000: PIPE8 1001: PIPE9

Note: When the PIPESEL bits are 0000, all bits of the PIPECFG, PIPEBUF, PIPEMAXP, and PIPEPERI registers are cleared. When the PIPESEL bits are 0000, writing to the registers at addresses H'68 to H'6E is ignored.

(1) Pipe Window select (PIPESEL) bits

When software a value from 0001 to 1111 to these bits, this module indicate the pipe information and settings corresponding to the registers at addresses H'68 to H'6E. After a pipe is selected by these bits, the values set in the areas at addresses H'68 to H'6E are applied, by this module, to the transfer operation using the selected pipe.

When writes 0000 to these bits, this module writes 0 to all bits of the registers at addresses H'68 to H'6E. Then, writing to the areas at addresses H'68 to H'6E is ignored.

32B.2.15.2 Pipe Configuration Register [PIPECFG] <Address: H'068>

Bit	15	14	13	12	11	10	9	8	7	6	5	4	3	2	1	0
	TYPE		—	—	—	BFRE	DBLB	CNTMD	SHTNAK	—	—	DIR	EPNUM			
Initial Value	0	0	0	0	0	0	0	0	0	0	0	0	0	0	0	0
R/W	R/W	R/W	R	R	R	R/W	R/W	R/W	R/W	R	R	R/W	R/W	R/W	R/W	R/W

Bit	Bit Name	Initial Value	R/W	Description
15, 14	TYPE	All 0	R/W	Transfer type These bits specify the transfer type of the pipe specified in the PIPESEL bit. 00: The pipe cannot be used. 01: Bulk transfer 10: Interrupt transfer 11: Isochronous transfer
13 to 11	—	All 0	R	Nothing is assigned to these bits. Fix these bits to 0.
10	BFRE	0	R/W	BRDY interrupt operation specification This bit specifies the timing at which this module notifies a BRDY interrupt relating to the specified pipe. 0: A BRDY interrupt is notified when data is sent or received. 1: A BRDY interrupt is notified when reading of data is completed.
9	DBLB	0	R/W	Double-buffer mode This bit specifies a single or double FIFO buffer to be used by the specified pipe. 0: Single buffer 1: Double buffer
8	CNTMD	0	R/W	Continuous transfer mode This bit specifies whether to use the specified pipe to perform communication in continuous transfer mode. 0: Non-continuous transfer mode 1: Continuous transfer mode
7	SHTNAK	0	R/W	Pipe disable at transfer end When the specified pipe is in the receiving direction, this bit specifies whether to change the PID setting to NAK when the transfer ends. 0: Continues the pipe when the transfer ends. 1: Disables the pipe when the transfer ends.
6, 5	—	All 0	R	Nothing is assigned to these bits. Fix these bits to 0.
4	DIR	0	R/W	Transfer direction This bit specifies the transfer direction of the specified pipe. 0: Receiving direction 1: Sending direction
3 to 0	EPNUM	All 0	R/W	Endpoint number These bits specify the endpoint number of the specified pipe.

(1) Transfer type (TYPE) bits

These bits are used to specify the USB transfer type of the pipe (selected pipe) specified in the PIPESEL bits.

Table 32B.12 lists pipes and the transfer types specifiable in these bits.

Table 32B.12 Selected Pipes and the Transfer Types Specifiable in the TYPE Bits

Selected Pipe	TYPE Bits	USB Transfer Type
PIPE1 or PIPE2	01 or 11	Bulk or isochronous transfer
PIPE3 to PIPE5	01	Bulk transfer
PIPE6 to PIPE9	10	Interrupt transfer

Always specify a value other than 00 in these bits for a selected pipe before setting the PID of the selected pipe to BUF (to start USB communication using the selected pipe).

The value of these bits for a selected pipe must be done while the PID of the selected pipe is NAK. If you change the value of these bits for a selected pipe after having changed the PID of the selected pipe from BUF to NAK, check, that, and the PBUSY bit is 0 before changing the value of these bits. Note, however, that, if this module has changed the PID of the selected pipe to NAK, the value of the PBUSY bit need not be checked.

(2) BRDY interrupt operation specification (BFRE) bit

This bit is valid when the selected PIPE is PIPE1 to PIPE5.

When set this bit and been using the selected pipe in the receiving direction (in other words, the DIR bit is 0), this module detects the end of transfer (when it occurs) and generates a BRDY interrupt when reading of the last packet ends.

If a BRDY interrupt occurs with the above settings, software must write 1 to the BCLR bit. The FIFO buffer allocated to the selected pipe remains unready for reception until 1 is written to the BCLR bit.

When set this bit and been using the selected pipe in the sending direction (in other words, the DIR bit is 1), this module does not generate any BRDY interrupt.

For details, see the description of the PIPEBRDY interrupt status bit.

Changing the value of this bit for a selected pipe must be done while the PID of the selected pipe is NAK and the selected pipe is not specified in the CURPIPE bits.

If you change the value of this bit for a selected pipe after the USB communication using the selected pipe, not only check the values of above three kinds of register bits but also write 1 and 0 successively to the ACLRM bit to clear the FIFO buffer allocated to the selected pipe.

If you change the value of this bit for a selected pipe after having changed the PID of the selected pipe from BUF to NAK, check, that, and the PBUSY bit is 0 before changing the value of this bit. Note, however, that, if this module has changed the PID of the selected pipe to NAK, the value of the PBUSY bit need not be checked.

(3) Double-buffer mode (DBLB) bit

This bit is valid when the selected pipe is PIPE1 to PIPE5.

When set this bit for a selected pipe, this module allocates, to the selected pipe, two FIFO buffers, each of which has the FIFO buffer size specified in the BUFSIZE bits in the PIPEBUF register.

The size of the FIFO buffer this module allocates to the selected pipe is as follows:

$$(\text{BUFSIZE} + 1) \times 64 \times (\text{DBLB} + 1) \text{ [bytes]}$$

Changing the value of this bit for a selected pipe must be done while the PID of the selected pipe is NAK and the selected pipe is not specified in the CURPIPE bits.

If you change the value of this bit for a selected pipe after the USB communication using the selected pipe, not only check the values of above three kinds of register bits but also write 1 and 0 successively to the ACLRM bit to clear the FIFO buffer allocated to the selected pipe.

If you change the value of this bit for a selected pipe after having changed the PID of the selected pipe from BUF to NAK, check, that, and the PBUSY bit is 0 before changing the value of this bit. Note, however, that, if this module has changed the PID of the selected pipe to NAK, the value of the PBUSY bit need not be checked.

(4) Continuous transfer mode (CNTMD) bit

This bit is valid when the selected pipe is PIPE1 to PIPE5, and the transfer type of the selected pipe is bulk transfer.

This module determines whether data sending from or receiving in the FIFO buffer allocated to the selected pipe has ended according to the value of this bit in the way described in **Table 32B.13**.

Table 32B.13 How to Determine the End of Data Sending from or Receiving in the FIFO Buffer According to the Value of the CNTMD Bit

CNTMD Bit Setting Value	How to Determine Whether Reading or Sending is Enabled
0	<p>Condition for enabling reading from the FIFO buffer when the receiving direction is set ("DIR = 0"): This module receives one packet</p> <hr/> <p>Condition for enabling sending from the FIFO buffer when the sending direction is set ("DIR = 1"): Either of the following conditions (1) and (2) is met: (1) Data for the maximum packet size is written to the FIFO buffer. (2) Data for the short packet (including the case of zero-byte data) is written to the FIFO buffer and then 1 is written in the BVAL bit.</p>
1	<p>Conditions for enabling reading from the FIFO buffer when the receiving direction is set ("DIR = 0"): (1) The number of bytes in data received in the FIFO buffer allocated to the selected pipe becomes equal to the number of allocated bytes ((BUFSIZE + 1) * 64). (2) This module receives a short packet other than a zero-length packet. (3) This controller receives a zero-length packet when the FIFO buffer allocated to the selected pipe already contains data. (4) Packets are received as many times as the value of the transaction counter set for the selected pipe.</p> <hr/> <p>Condition for enabling sending from the FIFO buffer when the sending direction is set ("DIR = 1"): One of the following conditions (1) to (3) is met: (1) The amount of written data becomes equal to the size of one FIFO buffer allocated to the selected pipe. (2) Data for less than the size of one FIFO buffer allocated to the selected pipe (including the case of zero-byte data) is written to the FIFO buffer and then 1 is written in the BVAL bit. (3) Data for less than the size of one FIFO buffer allocated to the selected pipe (including the case of zero-byte data) is written to the FIFO buffer, and a transfer end signal is asserted at the same time of the last writing.</p>

Changing the value of this bit for a selected pipe must be done while the PID of the selected pipe is NAK and the selected pipe is not specified in the CURPIPE bits.

If you change the value of this bit for a selected pipe after the USB communication using the selected pipe, not only check the values of above three kinds of register bits but also write 1 and 0 successively to the ACLRM bit to clear the FIFO buffer allocated to the selected pipe.

If you change the value of this bit for a selected pipe after having changed the PID of the selected pipe from BUF to NAK, check, that, and the PBUSY bit is 0 before changing the value of this bit. Note, however, that, if this module has changed the PID of the selected pipe to NAK, the value of the PBUSY bit need not be checked.

(5) PIPE disable at transfer end (SHTNAK) bit

This bit is valid when the selected pipe is PIPE1 to PIPE5 and is in the receiving direction.

When set this bit for a selected pipe in the receiving direction, this module changes the PID of the selected pipe to NAK when this module determines the end of data transfer to the selected pipe. This module determines the end of transfer when one of the following conditions (1) and (2) is met:

- (1) This module has normally received short packet data (including zero-length packets).
- (2) When using a transaction counter, this module has normally received as many packets as the value set in the transaction counter.

Changing the value of this bit for a selected pipe must be done while the PID of the selected pipe is NAK.

If you change the value of this bit for a selected pipe after having changed the PID of the selected pipe from BUF to NAK, check, that, and the PBUSY bit is 0 before changing the value of this bit. Note, however, that, if this module has changed the PID of the selected pipe to NAK, the value of the PBUSY bit need not be checked.

For the pipes in the sending direction, this bit must be cleared.

(6) Transfer direction (DIR) bit

When writes 0 to this bit for a selected pipe, this module uses the selected pipe in the receiving direction. When software writes 1 to this bit for the selected pipe, this module uses the selected pipe in the sending direction.

Changing the value of this bit for a selected pipe must be done while the PID of the selected pipe is NAK and the selected pipe is not specified in the CURPIPE bits.

If you change the value of this bit for a selected pipe after the USB communication using the selected pipe, not only check the values of above three kinds of register bits but also write 1 and 0 successively to the ACLRM bit to clear the FIFO buffer allocated to the selected pipe.

If you change the value of this bit for a selected pipe after having changed the PID of the selected pipe from BUF to NAK, check, that, and the PBUSY bit is 0 before changing the value of this bit. Note, however, that, if this module has changed the PID of the selected pipe to NAK, the value of the PBUSY bit need not be checked.

(7) Endpoint number (EPNUM) bits

These bits are used to specify the endpoint number of the endpoint of a selected pipe. Note that specifying 0000 in these bits for a pipe means that the pipe is not used.

Changing the value of these bits for a selected pipe must be done while the PID of the selected pipe is NAK and the selected pipe is not specified in the CURPIPE bits.

If you change the value of these bits for a selected pipe after having changed the PID of the selected pipe from BUF to NAK, check, that, and the PBUSY bit is 0 before changing the value of these bits. Note, however, that, if this module has changed the PID of the selected pipe to NAK, the value of the PBUSY bit need not be checked.

The combination of the values of the DIR bit and EPNUM bits for a pipe must be unique among those for all pipes. (The setting "EPNUM = 000" [the selected pipe is not used] can be duplicated for multiple pipes.)

32B.2.15.3 Pipe Buffer Setting Register [PIPEBUF] <Address: H'06A>

Bit	15	14	13	12	11	10	9	8	7	6	5	4	3	2	1	0	
	—	BUFSIZE						—	—	BUFNMB							
Initial Value	0	0	0	0	0	0	0	0	0	0	0	0	0	0	0	0	
R/W	R	R/W	R/W	R/W	R/W	R/W	R	R	R/W	R/W	R/W	R/W	R/W	R/W	R/W	R/W	

Bit	Bit Name	Initial Value	R/W	Description
15	—	0	R	Nothing is assigned to this bit. Fix this bit to 0.
14 to 10	BUFSIZE	All 0	R/W	Buffer size These bits specify the size of the FIFO buffer for the pipe specified in the PIPESEL bit. H'00: 64 bytes H'01: 128 bytes ... (H'1F: 2 Kbytes)
9, 8	—	All 0	R	Nothing is assigned to these bits. Fix these bits to 0.
7 to 0	BUFNMB	All 0	R/W	Buffer number These bits specify the FIFO buffer number of the specified pipe. (H'4 to H'7F)

Note: Changing values of these register bits for a selected pipe must be done when sets the PID of the selected pipe to NAK, and specifies no pipe in the CURPIPE bits.

Note: If you change values of these register bits for a selected pipe after having changed the PID of the selected pipe from BUF to NAK, check, that, and the PBUSY bit is 0 before changing the values of these bits. Note, however, that, if this module has changed the PID of the selected pipe to NAK, the value of the PBUSY bit need not be checked.

(1) Buffer size (BUFSIZE) bits

These bits are used to specify the size of the FIFO buffer to be allocated to the selected pipe. Specify the FIFO buffer size in units of blocks. One block has 64 bytes.

When set the DBLB bit for a selected pipe, this module allocates, to the selected pipe, two FIFO buffers, each of which has the FIFO buffer size specified in these bits.

The size of the FIFO buffer this module allocates to the selected pipe is as follows:

$$(\text{BUFSIZE} + 1) \times 64 \times (\text{DBLB} + 1) \text{ [bytes]}$$

The following value can be specified in these bits:

- (1) Any value from H'0 to H'1F when the selected pipe is PIPE1 to PIPE5.
- (2) H'0 only when the selected pipe is PIPE6 to PIPE9.

In continuous transfer mode (CNTMD = 1), specify an integral multiple of the maximum packet size in the BUFSIZE bits.

(2) Buffer number (BUFNMB) bits

These bits are used to specify the block number of the first block in the FIFO buffer to be allocated to the selected pipe. This module allocates the following blocks of FIFO buffer to the selected pipe:

Block with block number “BUFNMB” to the block with block number “BUFNMB + (BUFSIZE + 1) × (DBLB + 1) - 1”

The value of these bits must be H'04 to H'7F. Note, however, that the following rules must be observed: Value " H'00" is exclusively used for DCP.

Value “H'04” is exclusively used for PIPE6. When, however, PIPE6 is not used, this value can be used for another pipe. If PIPE6 is selected, writing to the BUFNMB bits is ignored. Then, this module automatically sets H'04 in the BUFNMB bits for PIPE6.

Value “H'05” is exclusively used for PIPE7. When, however, PIPE7 is not used, this value can be used for another pipe. If PIPE7 is selected, writing to the BUFNMB bits is ignored. Then, this module automatically sets H'05 in the BUFNMB bits for PIPE7.

Value “H'06” is exclusively used for PIPE8. When, however, PIPE8 is not used, this value can be used for another pipe. If PIPE8 is selected, writing to the BUFNMB bits is ignored. Then, this module automatically sets H'06 in the BUFNMB bits for PIPE8.

Value “H'07” is exclusively used for PIPE9. When, however, PIPE9 is not used, this value can be used for another pipe. If PIPE9 is selected, writing to the BUFNMB bits is ignored. Then, this module automatically sets H'07 in the BUFNMB bits for PIPE9.

32B.2.15.4 Pipe Maximum Packet Size Register [PIPEMAXP] <Address: H'06C>

Bit	15	14	13	12	11	10	9	8	7	6	5	4	3	2	1	0
	—	—	—	—	—	MXPS										
Initial Value	0	0	0	0	0	0	0	0	0	0 (1)	0	0	0	0	0	0
R/W	R	R	R	R	R	R/W	R/W	R/W	R/W	R/W	R/W	R/W	R/W	R/W	R/W	R/W

Bit	Bit Name	Initial Value	R/W	Description
15 to 11	—	All 0	R	Nothing is assigned to these bits. Fix these bits to 0.
10 to 0	MXPS	*Note	R/W	Maximum packet size These bits specify the maximum data payload size (maximum packet size) for the specified pipe. For PIPE6 to PIPE8, a value from H'1 to H'40 (bytes) can be set.

Note: The initial value of the MXPS bits is H'00 when no pipe is specified in the PIPESEL bits in the PIPESEL register or H'40 when a pipe is specified in the PIPESEL bits.

(1) Maximum packet size (MXPS) bits

These bits are used to specify the maximum data payload size (maximum packet size) for the selected pipe.

The initial value of these bits is H'40 (64 bytes).

- For PIPE1 and PIPE2, a value from H'1 (1 byte) to H'400 (1024 bytes) can be specified.
- For PIPE3 to PIPE5, H'8 (8 bytes), H'10 (16 bytes), H'20 (32 bytes), H'40 (64 bytes), or H'200 (512 bytes) can be specified. (Bits [2:0] are excluded.)
- For PIPE6 to PIPE9, a value from H'1 (1 byte) to H'40 (64 bytes) can be specified.

The value of the MXPS bits for individual transfer type must conform to the USB Specification.

Setting a value in these bits for a selected pipe must be done while the PID of the selected pipe is NAK and the selected pipe is not specified in the CURPIPE bits.

If you change the value of these bits for a selected pipe after having changed the PID of the selected pipe from BUF to NAK, check the PBUSY bit is 0 before changing the value of these bits. Note, however, that, if this module has changed the PID of the selected pipe to NAK, the value of the PBUSY bit need not be checked.

When the MXPS bits are all 0, data must not be written to the FIFO buffer, and the PID setting must not be changed to BUF.

32B.2.15.5 Pipe Cycle Control Register [PIPEPERI] <Address: H'06E>

Bit	15	14	13	12	11	10	9	8	7	6	5	4	3	2	1	0
	—	—	—	IFIS	—	—	—	—	—	—	—	—	—	IITV		
Initial Value	0	0	0	0	0	0	0	0	0	0	0	0	0	0	0	0
R/W	R	R	R	R/W	R	R	R	R	R	R	R	R	R	R/W	R/W	R/W

Bit	Bit Name	Initial Value	R/W	Description
15 to 13	—	All 0	R	Nothing is assigned to these bits. Fix these bits to 0.
12	IFIS	0	R/W	Isochronous IN buffer flush This bit specifies whether to perform a buffer flush when the pipe specified in the PIPESEL bit is used for isochronous IN transfer. 0: Does not perform a buffer flush. 1: Performs a buffer flush.
11 to 3	—	All 0	R	Nothing is assigned to these bits. Fix these bits to 0.
2 to 0	IITV	All 0	R/W	These bits specify the transfer interval of the specified pipe. The value to be specified is the frame timing multiplied by an n-th power of 2.

(1) Isochronous IN buffer flush (IFIS) bit

When the selected pipe is used for isochronous IN transfer, this bit is used to specify this module automatically clears the FIFO buffer if this module fails to receive the IN token from the USB host in a (micro) frame sent at intervals specified in the IITV bits.

In double-buffer mode (DBLB = 1), this module clears only the data in one buffer used earlier than the other.

This module clears the FIFO buffer when it receives an SOF packet immediately after the (micro) frame in which the IN token has to be received. Even if the SOF packet is corrupted, this module clears the FIFO buffer in the same timing to receive the SOF packet by the use of the internal interpolation function.

(2) Interval error detection interval (IITV) bits

These bits specify the interval of interval error detection for the selected pipe. The value to be specified is the frame timing multiplied by an n-th power of 2.

Setting a value in these bits for a selected pipe must be done while the PID of the selected pipe is NAK and the selected pipe is not specified in the CURPIPE bits.

If you change the value of these bits for a selected pipe after having changed the PID of the selected pipe from BUF to NAK, check that, and the PBUSY bit is 0 before changing the value of these bits. Note, however, that, if this module has changed the PID of the selected pipe to NAK, the value of the PBUSY bit need not be checked.

If you change the value specified in these bits to another after a USB communication, change the PID to NAK, and then set the ACLRM bit to initialize the interval timer before changing the value.

For PIPE3 to PIPE5 these bits are ignored. Write 0 to all these bits corresponding to PIPE3 to PIPE5.

You can specify a value in these bits when the transfer type of the selected pipe is isochronous.

(a) When the selected pipe is used for isochronous OUT transfer

If this module does not receive any data packet in the (micro) frame sent at intervals specified in the IITV bits, this module generates an NRDT interrupt.

This module generates an NRDY interrupt also if this module cannot receive data because an error, e.g., CRC error, has occurred in a data packet or because the FIFO buffer is full (such a situation might result if, for example, software [DMAC] delays in reading data from the FIFO buffer).

This module generates the NRDY interrupt when it receives an SOF packet. Even if the SOF packet is corrupted, this module generates the NRDY interrupt in the same timing to receive the SOF packet by the use of the internal interpolation function.

When, however, the value of the IITV bits is not 0, this module generates the NRDY interrupt every time an SOF packet is received at the specified intervals after interval counting starts.

If the PID of the selected pipe is changed to NAK after the interval timer starts, this module does not generate the NRDY interrupt even when it receives an SOF packet.

The condition for starting interval counting varies by the value of the IITV bits.

(a) When IITV = 0: Interval counting starts when the PID of the selected pipe is changed to BUF.

(Micro) frame	S O F	S O F	S O F	O U T	D A T A 0	S O F	O U T	D A T A 0
Setting of PID bits	NAK	NAK	BUF		BUF			
Whether token reception is expected (0: reception expected —: non-reception expected)	—	—	0		0			
Start of interval counting			↑					

Figure 32B.1 Relationship between (Micro) Frames and Whether Token Reception Is Expected When IITV = 0

- (b) When IITV is not 0: Interval counting starts at the end of the first normal reception of data packet after the PID of the selected pipe is changed to BUF.

(Micro) frame	S O F	S O F	S O F	O U T	D A T A 0	S O F	S O F	O U T	D A T A 0	S O F	S O F	O U T	D A T A 0
Setting of PID bits	NAK	BUF	BUF		BUF	BUF	BUF		BUF	BUF		BUF	
Whether token reception is expected (0: reception expected —: non-reception expected)	—	—	0		—	0		—	0		—	0	
Start of interval counting			↑										

Figure 32B.2 Relationship between (Micro) Frames and Whether Token Reception Is Expected When IITV = 1

(b) When the selected pipe is used for isochronous IN transfer

The IITV bits are used in combination with the setting of the IFIS bit to 1. When the IFIS bit is 0, this module sends a data packet in response to a received token regardless of the value of the IITV bits.

When the IFIS bit is 1, if this module does not receive any IN token in the (micro) frame sent at intervals specified in the IITV bits although the FIFO buffer has sendable data, this module clears the FIFO buffer.

This module clears the FIFO buffer also when it cannot receive an IN token normally because of a bus error, e.g., CRC error.

This module clears the FIFO buffer when it receives an SOF packet. Even if the SOF packet is corrupted, this module clears the FIFO buffer in the same timing to receive the SOF packet by the use of the internal interpolation function.

The condition for starting interval counting varies by the value of the IITV bits. (The condition is the same as that for isochronous OUT transfer.)

The interval counter is cleared when one of the following conditions (1) to (3) is met:

- (1) This module is reset (then, also the IITV bits are cleared).
- (2) The ACLRM bit is set.
- (3) This module detects a USB bus reset.

32B.2.16 Pipe Control Registers (PIPExCTR)

- 32B.2.16.1 PIPE1 Control Register [PIPE1CTR] <Address: H'070>**
PIPE2 Control Register [PIPE2CTR] <Address: H'072>
PIPE3 Control Register [PIPE3CTR] <Address: H'074>
PIPE4 Control Register [PIPE4CTR] <Address: H'076>
PIPE5 Control Register [PIPE5CTR] <Address: H'078>

Bit	15	14	13	12	11	10	9	8	7	6	5	4	3	2	1	0
	BSTS	INBUFM	—	—	—	ATREPM	ACLARM	SQCLR	SQSET	SQMON	PBUSY	—	—	—	PID	
Initial Value	0	0	0	0	0	0	0	0	0	0	0	0	0	0	0	0
R/W	R	R	R	R	R	R/W	R/W	R(0)/W(1)	R(0)/W(1)	R	R	R	R	R	R/W	R/W

Bit	Bit Name	Initial Value	R/W	Description
15	BSTS	0	R	Buffer status This bit indicates the FIFO buffer status of the specified pipe. 0: Buffer access is not possible. 1: Buffer access is possible.
14	INBUFM	0	R	Transmit buffer monitor When the specified pipe is in the sending direction, this bit indicates the FIFO buffer status of the specified pipe. 0: The FIFO buffer does not contain data that can be sent. 1: The FIFO buffer contains data that can be sent.
13 to 11	—	All 0	R	Nothing is assigned to these bits. Fix these bits to 0.
10	ATREPM	0	R/W	Automatic response mode This bit prohibits or enables automatic response of the specified pipe. 0: Automatic response prohibited 1: Automatic response enabled. (A zero-length packet response is sent during transmission. For reception, a NAK response is sent and an NRDY interrupt is generated.)
9	ACLARM	0	R/W	Automatic buffer clear mode This bit prohibits or enables automatic buffer clear mode for the specified pipe. 0: Prohibited 1: Enabled (all buffers are initialized)
8	SQCLR	0	R(0)/W(1)	Toggle bit clear Specify 1 in this bit to clear the expected value of the sequence toggle bit for the next transaction in the specified pipe to DATA0. 0: Writing disabled 1: DATA0 specified
7	SQSET	0	R(0)/W(1)	Toggle bit set Specify 1 in this bit to set the expected value of the sequence toggle bit for the next transaction in the specified pipe to DATA1. 0: Writing disabled 1: DATA1 specified
6	SQMON	0	R	Sequence toggle bit monitor This bit indicates the expected value of the sequence toggle bit for the next transaction in the specified pipe. 0: DATA0 1: DATA1

Bit	Bit Name	Initial Value	R/W	Description
5	PBUSY	0	R	Pipe busy This bit indicates whether the specified pipe is being used in the USB bus. 0: The specified pipe is not used in the USB bus. 1: The specified pipe is being used in the USB bus.
4 to 2	—	All 0	R	Nothing is assigned to these bits. Fix these bits to 0.
1, 0	PID	All 0	R/W	Response PID These bits specify the response method for the next transaction in the specified pipe. 00: NAK response 01: BUF response (according to the buffer status) 10: STALL response 11: STALL response

(1) Buffer status (BSTS) bit

This bit indicates whether the CPU can access the FIFO buffer allocated to the selected pipe. This bit is operated by this module.

The meaning of this bit varies as follows depending on the value of the values of the DIR, BFRE, and DCLRM bits:

Table 32B.14 BSTS Bit Operations

DIR bit Setting Value	BFRE bit Setting Value	DCLRM bit Setting Value	Meaning of the BSTS Bit
0	0	0	This bit indicates 1 when reading of received data from the FIFO buffer becomes possible, and indicates 0 when reading data has finished.
		1	Setting prohibited
	1	0	This bit indicates 1 when reading of received data from the FIFO buffer becomes possible. This bit indicates 0 when 1 is written in the BCLF bit after reading data has finished.
		1	This bit indicates 1 when reading of received data from the FIFO buffer becomes possible, and indicates 0 when reading data has finished.
1	0	0	This bit indicates 1 when writing of send data in the FIFO buffer becomes possible, and indicates 0 when writing data has finished.
		1	Setting prohibited
	1	0	Setting prohibited
		1	Setting prohibited

(2) Transmit buffer monitor (INBUFM) bit

When the selected pipe is in the sending direction (DIR = 1), this module sets this bit when software (or the DMAC) has finished writing data to at least one FIFO buffer.

This module clears this bit when this module finishes sending all data from the FIFO buffer to which the data has been written. In double-buffer mode (DBLB = 1), this module clears this bit when this module has finished sending all data from the two FIFO buffers and software (or the DMAC) has not yet finished writing data to one FIFO buffer.

When the selected pipe is in the receiving direction (DIR = 0), this bit indicates the same value as that of the BSTS bit.

(3) Automatic response mode (ATREPM) bit

This bit can be set when the transfer type of the selected pipe is bulk transfer.

When this bit is 1, this module responds to tokens sent from the USB host as described below.

1. When the selected pipe is used for bulk IN transfer (TYPE = 01 and DIR = 1)
 When the ATREPM bit is 1 and the PID of the selected pipe is BUF, this module responds to an IN token by sending a zero-length packet.
 Each time this module receives ACK from the USB host (the sequence of one transaction is receiving an IN token, sending a zero-length packet, and then receiving ACK), this module updates (toggles) the sequence toggle bit (DATA- PID).
 This module does not generate BRDY and BEMP interrupts.
2. When the selected pipe is used for bulk OUT transfer (TYPE = 01 and DIR = 0)
 When the ATREPM bit is 1 and the PID of the selected pipe is BUF, this module responds to an OUT token (or a PING token) by sending an NAK response and generates an NRDY interrupt.

Changing the value of this bit for a selected pipe must be done while the PID of the selected pipe is NAK.

If you change the value of this bit for a selected pipe after having changed the PID of the selected pipe from BUF to NAK, check, that the PBUSY bit is 0 before changing the value of this bit. Note, however, that, if this module has changed the PID of the selected pipe to NAK, the value of the PBUSY bit need not be checked.

To perform a USB communication with this bit set, the FIFO buffer must be empty. No data must be written to the FIFO buffer during the USB communication with this bit set.

When the transfer type of the selected pipe is isochronous transfer, this bit must always be 0.

(4) Automatic buffer clear mode (ACLRM) bit

When you need to clear the whole FIFO buffer allocated to the selected pipe, write 1 and 0 successively to the ACLRM bit.

Table 32B.15 shows the buffer contents this module clears when 1 and 0 are written successively to the ACLRM bit.

Table 32B.16 shows the cases that require this processing.

Table 32B.15 Buffer Contents This Core Clears When the ACLRM Bit is Set

No.	Contents to be Cleared by Setting the ACLRM Bit
(1)	Whole contents of the FIFO buffer allocated to the specified pipe (if the double buffer is set, both FIFO buffers are cleared)
(2)	If the transfer type of the specified pipe is Isochronous transfer, the interval count value is cleared.

Table 32B.16 Cases Requiring the ACLRM Bit to be Set

No.	Cases when Data Clear is Required
(1)	The whole contents of the FIFO buffer allocated to the specified pipe needs to be cleared.
(2)	The interval count value needs to be reset.
(3)	The value of the BFRE bit is changed.
(4)	The value of the DBLB bit is changed.
(5)	Forced termination of the transaction count function is performed.

Changing the value of this bit for a selected pipe must be done while the PID of the selected pipe is NAK and the selected pipe is not specified in the CURPIPE bits.

If you change the value of this bit for a selected pipe after having changed the PID of the selected pipe from BUF to NAK, check, that, and the PBUSY bit is 0 before changing the value of this bit. Note, however, that, if this module has changed the PID of the selected pipe to NAK, the value of the PBUSY bit need not be checked.

(5) Sequence toggle bit clear (SQCLR) bit

When software sets this bit, this module specifies DATA0 as the expected value of the sequence toggle bit for the selected pipe. This module always clears this bit.

Writing 1 to the SQCLR bit must be done when the PID of the selected pipe is NAK.

If you write 1 to this bit for a selected pipe after having changed the PID of the selected pipe from BUF to NAK, check, that the PBUSY bit is 0 before changing the value of this bit. Note, however, that, if this module has changed the PID of the selected pipe to NAK, the value of the PBUSY bit need not be checked.

(6) Sequence toggle bit set (SQSET) bit

When software sets this bit, this module specifies DATA1 as the expected value of the sequence toggle bit for the selected pipe. This module always clears this bit.

Writing 1 to the SQSET bit must be done when the PID of the selected pipe is NAK.

If you write 1 to this bit for a selected pipe after having changed the PID of the selected pipe from BUF to NAK, check, that the PBUSY bit is 0 before changing the value of this bit. Note, however, that, if this module has changed the PID of the selected pipe to NAK, the value of the PBUSY bit need not be checked.

(7) Sequence toggle bit monitor (SQMON) bit

This bit indicates the expected value of the sequence toggle bit for the selected pipe. This bit is operated by this module.

When the transfer type of the selected pipe is other than isochronous transfer, this module toggles this bit when a transaction ends normally. This module, however, does not toggle this bit if a DATA-PID mismatch occurs during a transfer in the receiving direction.

(8) Pipe busy (PBUSY) bit

This module changes this bit from 0 to 1 when a USB transaction using the selected pipe starts. This module changes this bit from 1 to 0 when the transaction ends normally.

Reading this bit after software sets the PID to NAK enables you to check whether you can change pipe settings.

(9) Response PID (PID) bits

These bits are used to specify, the type of response of this module for individual pipes.

The default of PID is NAK. When the selected pipe is used for USB transfers, the PID setting must be changed to BUF. For the basic operations (without communication packet errors involved) of this module depending on the value of the PID bits, see **Table 32B.17**.

If you have changed the PID of a selected pipe from BUF to NAK while the selected pipe is performing a USB communication, check, that the PBUSY bit is 0 to confirm that the USB transfer through the selected pipe has actually changed to the NAK status. Note, however, that, if this module has changed the PID of the selected pipe to NAK, the value of the PBUSY bit need not be checked.

This module changes the value of the PID bits in the following cases:

1. When the selected pipe is in the receiving direction and set the SHTNAK bit for the selected pipe, this module sets the PID to NAK when this module recognizes the end of a transfer.
2. When this module has received a data packet of which the payload size is larger than the maximum packet size, this module sets the PID to STALL (PID = 11).
3. If this module detects a USB bus reset, this module sets the PID to NAK.

To change the PID from NAK (PID = 00) to STALL, write 10 to the PID bits. To change the PID from BUF (PID = 01) to STALL, write 11 to the PID bits.

To change the PID from STALL (PID = 11) to NAK, write 10 to the PID bits once, and then write 00 to the PID bits. To change the PID from STALL to BUF, change the PID to NAK once, and then change it to BUF.

Table 32B.17 Core Operations Depending on the PID Setting

PID bit Setting Value	Transfer Type (TYPE Bit Setting Value)	Transfer Direction (DIR Bit Setting Value)	Operation of This Core
00 (NAK)	Bulk ("TYPE = 01"), or Interrupt ("TYPE = 10")	Independent of the setting value	Sends a NAK response for a token from the USB host.
		Receiving direction ("DIR = 0")	Does not respond to a token from the USB host.
	Isochronous ("TYPE = 11")	Sending direction ("DIR = 1")	Sends a zero-length packet for a token from the USB host.
01 (BUF)	Bulk ("TYPE = 01")	Receiving direction ("DIR = 0")	For an OUT token from the USB host, if the FIFO buffer corresponding to the specified PIPE can receive data, this module receives data and then sends an ACK or NYET response. If receiving data is not possible, this module sends a NAK response. For a PING Token from the USB host, if the FIFO buffer corresponding to the specified PIPE can receive data, this module sends an ACK response. If receiving data is not possible, this module sends a NAK response.
		Interrupt ("TYPE = 10")	Receiving direction ("DIR = 0")
	Bulk ("TYPE = 01") or Interrupt ("TYPE = 10")	Sending direction ("DIR = 1")	If the corresponding FIFO buffer is available for sending data, this module sends data in response to a token from the USB host. If sending data is not possible, this module sends a NAK response.
		Isochronous ("TYPE = 11")	Receiving direction ("DIR = 0")
	Sending direction ("DIR = 1")		If the corresponding FIFO buffer is available for sending data, this module sends data in response to a token from the USB host. If sending data is not possible, this module sends a zero-length packet.
	10 (STALL) or 11 (STALL)	Bulk ("TYPE = 01") or Interrupt ("TYPE = 10")	Independent of the setting value
Isochronous ("TYPE = 11")			Independent of the setting value

32B.2.16.2 PIPE6 Control Register [PIPE6CTR] <Address: H'07A>
PIPE7 Control Register [PIPE7CTR] <Address: H'07C>
PIPE8 Control Register [PIPE8CTR] <Address: H'07E>
PIPE9 Control Register [PIPE9CTR] <Address: H'080>

Bit	15	14	13	12	11	10	9	8	7	6	5	4	3	2	1	0
	BSTS	—	—	—	—	—	ACLRM	SQCLR	SQSET	SQMON	PBUSY	—	—	—	PID	
Initial Value	0	0	0	0	0	0	0	0	0	0	0	0	0	0	0	0
R/W	R	R	R	R	R	R	R/W	R(0)/W(1)	R(0)/W(1)	R	R	R	R	R	R/W	R/W

Bit	Bit Name	Initial Value	R/W	Description
15	BSTS	0	R	Buffer status This bit indicates the FIFO buffer status of the specified pipe. 0: Buffer access is not possible. 1: Buffer access is possible.
14 to 10	—	All 0	R	Nothing is assigned to these bits. Fix these bits to 0.
9	ACLRM	0	R/W	Automatic buffer clear mode This bit prohibits or enables automatic buffer clear mode for the specified pipe. 0: Automatic buffer clear mode prohibited 1: Automatic buffer clear mode enabled (all buffers are initialized)
8	SQCLR	0	R(0)/W(1)	Toggle bit clear Specify 1 in this bit to clear the expected value of the sequence toggle bit for the next transaction in the specified pipe to DATA0. 0: Disabled 1: DATA0 specified
7	SQSET	0	R(0)/W(1)	Toggle bit set Specify 1 in this bit to set the expected value of the sequence toggle bit for the next transaction in the specified pipe to DATA1 0: Disabled 1: DATA1 specified
6	SQMON	0	R	Toggle bit monitor This bit indicates the expected value of the sequence toggle bit for the next transaction in the specified pipe. 0: DATA0 1: DATA1
5	PBUSY	0	R	Pipe busy This bit indicates whether the specified pipe is being used in the USB bus. 0: The specified pipe is not used in the USB bus. 1: The specified pipe is being used in the USB bus.
4 to 2	—	All 0	R	Nothing is assigned to these bits. Fix these bits to 0.
1, 0	PID	All 0	R/W	Response PID These bits specify the response method for the next transaction in the specified pipe 00: NAK response 01: BUF response (according to the buffer status) 10: STALL response 11: STALL response

(1) Buffer status (BSTS) bit

See **Section 32B.2.16.1(2), Transmit buffer monitor (INBUFM) bit.**

(2) Automatic buffer clear mode (ACLRM) bit

When you need to clear the whole FIFO buffer allocated to the selected pipe, write 1 and 0 successively to the ACLRM bit.

Table 32B.18 shows the buffer contents this module clears when 1 and 0 are written successively to the ACLRM bit.

Table 32B.19 shows the cases that require this processing.

Table 32B.18 Buffer Contents This Core Clears when the ACLRM Bit is Set

No.	Contents Cleared by ACLRM Bit Operation
(1)	All contents of the FIFO buffer allocated to the selected pipe

Table 32B.19 Cases Requiring the ACLRM Bit to be Set

No.	Contents Cleared by ACLRM Bit Operation
(1)	When clearing contents of the FIFO buffer allocated to the selected pipe
(2)	When resetting the interval counter
(3)	When the value of the BFRE bit is changed
(4)	When the transaction count function is terminated forcibly

Changing the value of this bit for a selected pipe must be done while the PID of the selected pipe is NAK and the selected pipe is not specified in the CURPIPE bits.

If you change the value of this bit for a selected pipe after having changed the PID of the selected pipe from BUF to NAK, check, that, and the PBUSY bit is 0 before changing the value of this bit. Note, however, that, if this module has changed the PID of the selected pipe to NAK, the value of the PBUSY bit need not be checked.

(3) Sequence toggle bit clear (SQCLR) bit

See **Section 32B.2.16.1(5), Sequence toggle bit clear (SQCLR) bit.**

(4) Sequence toggle bit set (SQSET) bit

See **Section 32B.2.16.1(6), Sequence toggle bit set (SQSET) bit.**

(5) Sequence toggle bit monitor (SQMON) bit

See **Section 32B.2.16.1(7), Sequence toggle bit monitor (SQMON) bit.**

(6) Pipe busy (PBUSY) bit

See **Section 32B.2.16.1(8), Pipe busy (PBUSY) bit.**

(7) Response PID (PID) bits

See **Section 32B.2.16.1(9), Response PID (PID) bits.**

32B.2.17 Transaction Counters (PIPExTRE)

- 32B.2.17.1 PIPE1 Transaction Counter Enable Register [PIPE1TRE] <Address: H'090>**
PIPE2 Transaction Counter Enable Register [PIPE2TRE] <Address: H'094>
PIPE3 Transaction Counter Enable Register [PIPE3TRE] <Address: H'098>
PIPE4 Transaction Counter Enable Register [PIPE4TRE] <Address: H'09C>
PIPE5 Transaction Counter Enable Register [PIPE5TRE] <Address: H'0A0>

Bit	15	14	13	12	11	10	9	8	7	6	5	4	3	2	1	0
	—	—	—	—	—	—	TRENB	TRCLR	—	—	—	—	—	—	—	—
Initial Value	0	0	0	0	0	0	0	0	0	0	0	0	0	0	0	0
R/W	R	R	R	R	R	R	R/W	R(0)/W(1)	R	R	R	R	R	R	R	R

Bit	Bit Name	Initial Value	R/W	Description
15 to 10	—	All 0	R	Nothing is assigned to these bits. Fix these bits to 0.
9	TRENB	0	R/W	Transaction counter enable This bit enables or disables the transaction counter. 0: Disables the transaction counter. 1: Enables the transaction counter.
8	TRCLR	0	R(0)/W(1)	Transaction counter clear This bit clears the transaction counter to 0. To clear the counter, write 1 to this bit. 0: Invalid 1: Clears the current transaction counter.
7 to 0	—	All 0	R	Nothing is assigned to these bits. Fix these bits to 0.

Note: Changing values of these register bits for a selected pipe must be done when the PID of the selected pipe is NAK. If you change the value of a bit for a selected pipe after having changed the PID of the selected pipe from BUF to NAK, check that the PBUSY bit is 0 before changing the value of the bit. Note, however, that, if this module has changed the PID of the selected pipe to NAK, the value of the PBUSY bit need not be checked.

(1) Transaction counter enable (TRENB) bit

When software sets this bit for the selected pipe in the receiving direction after specifying a total number of packets in the TRNCNT bits, this module performs the following control when it finishes receiving the same number of packets as the total number specified in the TRNCNT bits:

1. When the continuous transfer mode is used (CNTMD = 1), this module switches the FIFO buffer to the CPU side at the end of reception even if the FIFO buffer is not full.
2. When the SHTNAK bit is 1, this module changes the PID of the selected pipe to NAK when it finishes receiving the same number of packets as the total number specified in the TRNCNT bits.
3. When the DENDE bit is 1 and the PKTMD bit is 0, this module asserts the DEND signal when reading the last data after having received the same number of packets as the total number specified in the TRNCNT bits.
4. When the BFRE bit is 1, this module asserts the BRDY interrupt signal when it finishes reading the last data after having received the same number of packets as the total number specified in the TRNCNT bits.

For the pipe in the sending direction, write 0 to this bit (TRENB bit). When not using the transaction count function, write 0 to this bit.

When using the transaction count function, specify a value in the TRNCNT bits before writing 1 to this bit. Also, write 1 to this bit before receiving the first packet among those to be counted by the transaction count function.

(2) Transaction counter clear (TRCLR) bit

When software sets this bit for a selected pipe, this module clears the current value of the transaction counter corresponding to the selected pipe, and then clears this bit.

32B.2.17.2 PIPE1 Transaction Counter Register [PIPE1TRN] <Address: H'092>
PIPE2 Transaction Counter Register [PIPE2TRN] <Address: H'096>
PIPE3 Transaction Counter Register [PIPE3TRN] <Address: H'09A>
PIPE4 Transaction Counter Register [PIPE4TRN] <Address: H'09E>
PIPE5 Transaction Counter Register [PIPE5TRN] <Address: H'0A2>

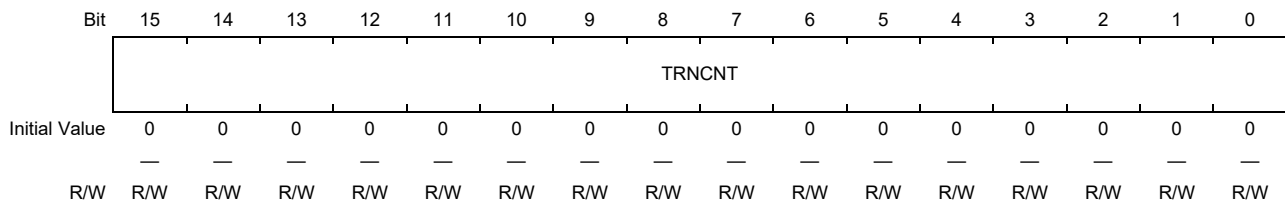

Bit	Bit Name	Initial Value	R/W	Description
15 to 0	TRNCNT	All 0	R/W	When writing: Specifies the total number of packets to be received by the pertinent pipe (number of transactions). When reading: Indicates the specified number of transactions if TRENB is 0. Indicates the number of the currently counted transaction if TRENB is 1.

(1) Transaction counter (TRNCNT) bits

When software writes 1 to the TRENB bit after setting the total number of packets to be received for the selected pipe in the receiving direction, this module performs the control described in **Section 32B.2.17.1(1), Transaction counter enable (TRENB) bit**.

When the TRENB bit is 0, this module indicates, by these bits, the number of transactions set.

When the TRENB bit is 1, this module indicates, by these bits, the current number of transactions counted.

This module increments the value of the TRNCNT bits by 1 when the status of reception meets all the following conditions (a) to (c):

- The TRENB bit is 1.
- When a packet is received, the value of the TRCNT bits is not equal to “current count + 1.”
- The payload size of received packets has reached the value of the MXPS bits.

This module clears the TRNCNT bits to 0 when any of the following conditions (1) to (3) is met:

- All the following conditions (a) to (c) are met:
 - The TRENB bit is 1.
 - When a packet is received, the value of the TRCNT bits is equal to “current count + 1.”
 - The payload size of received packets has reached the value of the MXPS bits.
- Both of the following conditions (a) and (b) are met:
 - The TRENB bit is 1.
 - A short packet has been received.

(3) The following condition is met:

(a) Written 1 to the TRCLR bit.

For the pipe in the sending direction, write 0 to these bits (TRNCNT bits). When not using the transaction count function, write 0 to these bits.

Changing the value of these bits for a selected pipe must be done while the PID of the selected pipe is NAK and the TRENb bit is 0.

If you change the value of this bit for a selected pipe after having changed the PID of the selected pipe from BUF to NAK, check, that, and the PBUSY bit is 0 before changing the value of this bit. Note, however, that, if this module has changed the PID of the selected pipe to NAK, the value of the PBUSY bit need not be checked.

If you change the value of these bits, write 1 to the TRCLR bit before writing 1 to the TRENb bit.

32B.2.18 Low Power Control Register

32B.2.18.1 Low Power Control Register [LPCTRL] <Address: H'100>

Bit	15	14	13	12	11	10	9	8	7	6	5	4	3	2	1	0
	—	—	—	—	—	—	—	—	HWUP M	—	—	—	—	—	—	—
Initial Value	0	0	0	0	0	0	0	0	0	0	0	0	0	0	0	0
R/W	R	R	R	R	R	R	R	R	R/W	R	R	R	R	R	R	R

Bit	Bit Name	Initial Value	R/W	Description
15 to 8	—	All 0	R	Reserved Nothing is assigned to these bits. Fix these bits to 0.
7	HWUPM	0	R/W	0: Resumes the PHY from the low-power mode while the internal bus clock (P1 ϕ) is operating. 1: Enables resume from the low-power mode while the internal bus clock (P1 ϕ) is stopped.
6 to 0	—	All 0	R	Nothing is assigned to these bits. Fix these bits to 0.

(1) HWUPM

This bit is used to specify whether to enable resumption from the low-power mode even while the internal bus clock (P1 ϕ) is stopped.

0: Disables resumption while the internal bus clock (P1 ϕ) is stopped.

1: Enables resumption while the internal bus clock (P1 ϕ) is stopped.

This bit specifies whether to detect resume signaling while the internal bus clock (P1 ϕ) is stopped. Whether to resume is controlled by the L1EXTMD bit. To resume from the low-power mode (LPM L1 state) while the internal bus clock (P1 ϕ) is stopped, set both this bit and the L1EXTMD bit.

32B.2.19 Low Power Status Register

32B.2.19.1 Low Power Status Register [LPSTS] <Address: H'102>

Bit	15	14	13	12	11	10	9	8	7	6	5	4	3	2	1	0
	—	SUSPM	—	—	—	—	—	—	—	—	—	—	—	—	—	—
Initial Value	0	0	0	0	0	0	0	0	0	0	0	0	0	0	0	0
R/W	R	R/W	R	R	R	R	R	R	R	R	R	R	R	R	R	R

Bit	Bit Name	Initial Value	R/W	Description
15	—	0	R	Nothing is assigned to this bit. Fix this bit to 0.
14	SUSPM	0	R/W	USBPHY Suspend M control This bit controls the Suspend M signal to the USBPHY. 0: USBPHY suspend mode 1: USBPHY normal mode
13 to 0	—	All 0	R	Nothing is assigned to these bits. Fix these bits to 0.

(1) USBPHY SuspendM control (SUSPM) bit

This bit is used to control the SuspendM signal to the USBPHY. By default, the value of this bit is 0 and the USBPHY is in suspend mode. To operate this module, write 1 to this bit.

When the SUSPM bit is 0 (that is, when the UTMI clock is stopped), data cannot be written to this module, but can only be read from this module. Note, however, that data can be written to the registers listed in **Table 32B.20**.

Table 32B.20 Registers That Allow Writing when the SUSPM Bit is 0

Address	Register Name
H'000	SYSCFG0
H'002	BUSWAIT
H'100	LPCTRL
H'102	SUSPMODE

Note that the values written to the SYSCFG0 register while the USBPHY clock is stopped (SUSPM = 0) will be applied after the USBPHY clock starts (SUSPM = 1).

When the L1EXTMD bit is 0, this bit (SUSPM bit) is controlled (set or cleared) by software. When L1EXTMD bit is 1, this bit is controlled by software for the transition to the L1 or L2 state, and controlled by hardware for resumption from the L1 or L2 state, regardless of the level (L1 or L2).

32B.2.20 PHY Function Control Register

32B.2.20.1 PHY Function Control Register [PHYFUNCTR] <Address: H'104>

Bit	15	14	13	12	11	10	9	8	7	6	5	4	3	2	1	0
	—	SusMon	—	—	—	—	—	—	—	—	—	—	—	—	—	—
Initial Value	0	0	0	0	0	0	0	0	0	0	0	0	0	0	0	0
R/W	R	R	R	R	R	R	R	R	R	R	R	R	R	R	R	R

Bit	Bit Name	Initial Value	R/W	Description
15	—	0	R	Nothing is assigned to this bit. Fix this bit to 0.
14	SusMon	0	R	This bit allows reading of the status of the Suspend M signal.
13 to 0	—	All 0	R	Nothing is assigned to these bits. Fix these bits to 0.

(1) SusMon

SuspendM monitor bit (read only)

The status of the Suspend M signal can be read.

32B.2.21 PHY_OTG Control Register (PHYOTGCTR)

32B.2.21.1 PHY_OTG Control Register [PHYOTGCTR] <Address: H'10A>

Bit	15	14	13	12	11	10	9	8	7	6	5	4	3	2	1	0
	—	—	—	—	—	DmPuD wn	DpPuD wn	—	—	—	—	—	—	—	—	—
Initial Value	0	0	0	0	0	1	1	0	0	0	0	0	0	0	0	0
R/W	R	R	R	R	R	R	R	R	R	R	R	R	R	R	R	R

Bit	Bit Name	Initial Value	R/W	Description
15 to 11	—	All 0	R	Nothing is assigned to these bits. Fix these bits to 0.
10	DmPuDwn	1	R	Dm Pulldown monitor bit
9	DpPuDwn	1	R	Dp Pulldown monitor bit
8 to 0	—	All 0	R	Nothing is assigned to these bits. Fix these bits to 0.

(1) DmPuDwn

DmPulldown monitor bit (read only)

0: 15-kΩ Pulldown resistor control on the DM side is disabled.

1: 15-kΩ Pulldown resistor control on the DM side is enabled.

(2) DpPuDwn

DpPulldown monitor bit (read only)

0: 15-kΩ Pulldown resistor control on the DP side is disabled.

1: 15-kΩ Pulldown resistor control on the DP side is enabled.

32B.2.22 Peripheral L1 Control Register 1 (PL1CTRL)

32B.2.22.1 Peripheral L1 Control Register 1 [PL1CTRL1] <Address: H'144>

Bit	15	14	13	12	11	10	9	8	7	6	5	4	3	2	1	0
	—	L1EXTMD	—	—	HIRDTHR[3:0]				DVSQ[3:0]				L1NEGOMD	L1RESPMD[1:0]	L1RESPEN	
Initial Value	0	0	0	0	0	0	0	0	0	0	0	0	0	0	0	0
R/W	R	—	R	R	R/W	R/W	R/W	R/W	R	R	R	R	R/W	R/W	R/W	R/W

Bit	Bit Name	Initial Value	R/W	Description
15	—	0	R	Nothing is assigned to this bit. Fix this bit to 0.
14	L1EXTMD	0	R/W	USBPHY control mode on resumption from the L1 state This bit controls the USBPHY resume operation on resumption from the L1 state. 0: Does not set the Suspend M bit when the Host K signal is received. 1: Sets the Suspend M bit when the Host K signal is received
13, 12	—	All 0	R	Nothing is assigned to these bits. Fix these bits to 0.
11 to 8	HIRDTHR[3:0]	All 0	R/W	L1 response negotiation threshold HIRD threshold to be used for the L1NEGOMD bit The format is the same as the HIRD field of the HL1CTRL register.
7	DVSQ[3]	0	R	DVSQ extension bit This bit combined with the device state (DVSQ[2:0]) bit indicates the L1 state. 0000b: Powered state 0001b: Default state 0010b: Address state 0011b: Configured state 01xxb: Suspended state 10xxb: L1 state
6 to 4	DVSQ[2:0]	All 0	R	These bits mirror the DVSQ[2:0] bits in INTSTS0.
3	L1NEGOMD	0	R/W	L1 response negotiation control This bit sets the negotiation function using for the HIRD value. 0: Returns an ACK response if the received HIRD value is larger than the value of the HIRDTHR[3:0] bits. In other cases (including same values), an NYET response is returned. 1: Returns an ACK response if the received HIRD value is smaller than the value of the HIRDTHR[3:0] bits. In other cases (including same values), an NYET response is returned. This bit is valid only when the value of the L1RESPMD[1:0] bit is 11b.
2, 1	L1RESPMD[1:0]	All 0	R/W	L1 response mode These bits specify how to respond to an LPM token. 00b: NYET 01b: ACK 10b: STALL 11b: Response according to the value of the L1NEGOMD bit
0	L1RESPEN	0	R/W	L1 response enable This bit enables an L1 response. 0: Does not support LPM. 1: Supports LPM.

(1) L1 EXT mode (L1EXTMD) bit

This bit specifies how to control the SuspendM bit upon receiving the Host K signal when the USBPHY is stopped by setting the SuspendM bit in the L1 state.

0: Does not set the SuspendM bit when this module is resumed from the L1 state.

1: Sets the SuspendM bit when this module is resumed from the L1 state.

NOTES

1. The Host K period lasts a minimum of 50 μ s. Therefore, the USBPHY might be unable to be resumed within the Host K period if the software settings for resume same as those for the suspend state are applied. Because the initial value of this bit is controlled by software, set this bit at initialization when the L1 state is to be supported.
2. For the transition to the L1 state, the SuspendM bit is controlled by software regardless of the value of this bit.
3. When this bit is set, the SuspendM bit will be set also at resumption from the L2 state.

(2) HIRD negotiation threshold (HIRDTHR[3:0]) bits

These bits specify the value of HIRD threshold to be used for the negotiation specified by the L1NEGOMD bit.

The format of the value is the same as that of the HIRD field in the HL1CTRL register.

(3) Device state extension (DVSQ[3]) bit

This bit is used as the fourth bit for the device state (DVSQ) bits.

0000b: Powered state

0001b: Default state

0010b: Address state

0011b: Configured state

01xxb: Suspended state

10xxb: L1 state

(4) Device status (DVSQ[2:0]) bits

These bits mirror the DVSQ[2:0] bits in the Interrupt Status Register (INTSTS0).

(5) L1 negotiation mode (L1NEGOMD) bit

This bit is used to specify the negotiation function using the HIRD value.

0: Returns an ACK response when the received HIRD value is larger than the value in HIRDTHR[3:0] bits, or returns an NYET response in other cases.

1: Returns an ACK response when the received HIRD value is smaller than the value in HIRDTHR[3:0] bits, or returns an NYET response in other cases.

This bit is valid only when the value of L1RESPMD[1:0] bits is 11b.

(6) L1 response mode (L1RSPMD[1:0]) bits

When the L1RSPED bit is set, this module responds to an LPM token according to the value of these bits. These bits specify how to respond to the LPM token.

00b: NYET

01b: ACK

10b: STALL

11b: Response according to the value of L1NEGOMD bit

(7) L1 response enable (L1RSPEN) bit

When this bit is 0, this module does not respond to the LPM token it receives. When this bit is 1, this module responds to the LPM token (it receives) according to the value of the LPMRESPMD[1:0] bits.

32B.2.23 Peripheral L1 Control Register 2

32B.2.23.1 Peripheral L1 Control Register 2 [PL1CTRL2] <Address: H'146>

Bit	15	14	13	12	11	10	9	8	7	6	5	4	3	2	1	0
	—	—	—	RWEM ON	HIRDMON[3:0]			—	—	—	—	—	—	—	—	—
Initial Value	0	0	0	0	0	0	0	0	0	0	0	0	0	0	0	0
R/W	R	R	R	R/W	R/W	R/W	R/W	R/W	R	R	R	R	R	R	R	R

Bit	Bit Name	Initial Value	R/W	Description
15 to 13	—	All 0	R	Nothing is assigned to these bits. Fix these bits to 0.
12	RWEMON	0	R/W	This bit reflects the value of the RWE bit in the LPM token received last.
11 to 8	HIRDMON[3:0]	All 0	R/W	These bits reflect the value of the HIRD field in the LPM token received last.
7 to 0	—	All 0	R	Nothing is assigned to these bits. Fix these bits to 0.

(1) RWE value monitor (RWEMON) bit

This bit is referenced to monitor the value of the RWE bit in a received LPM token.

This bit reflects the value of the RWE bit in the LPM token received last.

(2) HIRD value monitor (HIRDMON) bits

These bits are referenced to monitor the value of the HIRD field in a received LPM token.

These bits reflect the value of the HIRD field in the LPM token received last.

32B.3 Next Register Set

32B.3.1 Next Source Address Register n

- 32B.3.1.1 **Next0 Source Address Register ch0 [N0SA_0] <Address: H'400>**
Next1 Source Address Register ch0 [N1SA_0] <Address: H'40C>
Next0 Source Address Register ch1 [N0SA_1] <Address: H'440>
Next1 Source Address Register ch1 [N1SA_1] <Address: H'44C>

Bit	31	30	29	28	27	26	25	24	23	22	21	20	19	18	17	16
	SA (in normal mode), WD (in write-only mode)															
Initial Value	0	0	0	0	0	0	0	0	0	0	0	0	0	0	0	0
R/W	R/W	R/W	R/W	R/W	R/W	R/W	R/W	R/W	R/W	R/W	R/W	R/W	R/W	R/W	R/W	R/W
Bit	15	14	13	12	11	10	9	8	7	6	5	4	3	2	1	0
	SA (in normal mode), WD (in write-only mode)															
Initial Value	0	0	0	0	0	0	0	0	0	0	0	0	0	0	0	0
R/W	R/W	R/W	R/W	R/W	R/W	R/W	R/W	R/W	R/W	R/W	R/W	R/W	R/W	R/W	R/W	R/W

Bit	Bit Name	Initial Value	R/W	Description
31 to 0	SA (in normal mode)	All 0	R/W	Source Address These bits specify the start address of the DMA transfer source.
	WD (in write-only mode)	All 0	R/W	Write Data These bits specify the write data in write-only mode.

Note: In a transfer in link mode, the data in the N0SA_n register is overwritten with descriptor read data.

32B.3.2 Next Destination Address Register n

- 32B.3.2.1 Next0 Destination Address Register ch0 [N0DA_0] <Address: H'404>**
Next1 Destination Address Register ch0 [N1DA_0] <Address: H'410>
Next0 Destination Address Register ch1 [N0DA_1] <Address: H'444>
Next1 Destination Address Register ch1 [N1DA_1] <Address: H'450>

Bit	31	30	29	28	27	26	25	24	23	22	21	20	19	18	17	16
	DA															
Initial Value	0	0	0	0	0	0	0	0	0	0	0	0	0	0	0	0
R/W	R/W	R/W	R/W	R/W	R/W	R/W	R/W	R/W	R/W	R/W	R/W	R/W	R/W	R/W	R/W	R/W
Bit	15	14	13	12	11	10	9	8	7	6	5	4	3	2	1	0
	DA															
Initial Value	0	0	0	0	0	0	0	0	0	0	0	0	0	0	0	0
R/W	R/W	R/W	R/W	R/W	R/W	R/W	R/W	R/W	R/W	R/W	R/W	R/W	R/W	R/W	R/W	R/W

Bit	Bit Name	Initial Value	R/W	Description
31 to 0	DA	All 0	R/W	Destination Address These bits specify the start address of the DMA transfer destination.

Note: In a transfer in link mode, the data in the N0DA_n register is overwritten with descriptor read data.

32B.3.3 Next Transaction Byte Register n

- 32B.3.3.1 Next0 Transaction Byte Register ch0 [N0TB_0] <Address: H'408>**
Next1 Transaction Byte Register ch0 [N1TB_0] <Address: H'414>
Next0 Transaction Byte Register ch1 [N0TB_1] <Address: H'448>
Next1 Transaction Byte Register ch1 [N1TB_1] <Address: H'454>

Bit	31	30	29	28	27	26	25	24	23	22	21	20	19	18	17	16
	TB															
Initial Value	0	0	0	0	0	0	0	0	0	0	0	0	0	0	0	0
R/W	R/W	R/W	R/W	R/W	R/W	R/W	R/W	R/W	R/W	R/W	R/W	R/W	R/W	R/W	R/W	R/W
Bit	15	14	13	12	11	10	9	8	7	6	5	4	3	2	1	0
	TB															
Initial Value	0	0	0	0	0	0	0	0	0	0	0	0	0	0	0	0
R/W	R/W	R/W	R/W	R/W	R/W	R/W	R/W	R/W	R/W	R/W	R/W	R/W	R/W	R/W	R/W	R/W

Bit	Bit Name	Initial Value	R/W	Description
31 to 0	TB	All 0	R/W	Transaction Byte These bits specify the total number of transfer bytes.

Note: Do not start a DMA transaction with 0 set in these bits.

Note: The N0TB_n register is overwritten by the descriptor read data during link mode transfer.

32B.4 Current Register Set

32B.4.1 Current Source Address Register

32B.4.1.1 Current Source Address Register ch0 [CRSA_0] <Address: H'418> Current Source Address Register ch1 [CRSA_1] <Address: H'458>

Bit	31	30	29	28	27	26	25	24	23	22	21	20	19	18	17	16
	CRSA															
Initial Value	0	0	0	0	0	0	0	0	0	0	0	0	0	0	0	0
R/W	R	R	R	R	R	R	R	R	R	R	R	R	R	R	R	R
Bit	15	14	13	12	11	10	9	8	7	6	5	4	3	2	1	0
	CRSA															
Initial Value	0	0	0	0	0	0	0	0	0	0	0	0	0	0	0	0
R/W	R	R	R	R	R	R	R	R	R	R	R	R	R	R	R	R

Bit	Bit Name	Initial Value	R/W	Description
31 to 0	CRSA	All 0	R	<p>Current Source Address Register</p> <p>This register indicates the read address for the next DMA transaction. The value of this register is incremented automatically while DMA transactions are in process. (When the SAD bit in the CHCFG_n register is 1, the value of this register is fixed. When the WONLY bit in the CHCFG_n register is 1, the value of this register is undefined.)</p> <p>The initial value of this register is loaded from the following register:</p> <ul style="list-style-type: none"> In register mode: <ul style="list-style-type: none"> A transfer source address is loaded from the Next0/1 Register Set. In link mode: <ul style="list-style-type: none"> A transfer source address is loaded from the descriptor. (The descriptor read data is input to the NOSA_n register, and is loaded into the CRSA_n register when a transfer starts.) <p>The value of this register is incremented when a read transfer ends.</p> <p>Read this register after DMA stops (that is, after the TACT bit in the CHSTAT_n register is cleared). (Handle the value read during DMA only as a reference value.)</p>

32B.4.2 Current Destination Address Register

32B.4.2.1 Current Destination Address Register ch0 [CRDA_0] <Address: H'41C> Current Destination Address Register ch1 [CRDA_1] <Address: H'45C>

Bit	31	30	29	28	27	26	25	24	23	22	21	20	19	18	17	16
	CRDA															
Initial Value	0	0	0	0	0	0	0	0	0	0	0	0	0	0	0	0
R/W	R	R	R	R	R	R	R	R	R	R	R	R	R	R	R	R
Bit	15	14	13	12	11	10	9	8	7	6	5	4	3	2	1	0
	CRDA															
Initial Value	0	0	0	0	0	0	0	0	0	0	0	0	0	0	0	0
R/W	R	R	R	R	R	R	R	R	R	R	R	R	R	R	R	R

Bit	Bit Name	Initial Value	R/W	Description
31 to 0	CRDA	All 0	R	<p>Current Destination Address Register</p> <p>This register indicates the write address for the next DMA transaction. The value of this register is incremented automatically while DMA transactions are in process. (When the DAD bit in the CHCFG_n register is 1, the value of this register is fixed.)</p> <p>The initial value of this register is loaded from the following register:</p> <p style="margin-left: 20px;">In register mode: A transfer destination address is loaded from the Next0/1 Register Set.</p> <p style="margin-left: 20px;">In link mode: A transfer destination address is loaded from the descriptor. (The descriptor read data is input to the NODA_n register, and is loaded into the CRDA_n register when a transfer starts.)</p> <p>The value of this register is incremented when a write transfer ends.</p> <p>Read this register after DMA stops (that is, after the TACT bit in the CHSTAT_n register is cleared). (Handle the value read during DMA only as a reference value.)</p>

32B.4.3 Current Transaction Byte Register

32B.4.3.1 Current Transaction Byte Register ch0 [CRTB_0] <Address: H'420>

Current Transaction Byte Register ch1 [CRTB_1] <Address: H'460>

Bit	31	30	29	28	27	26	25	24	23	22	21	20	19	18	17	16
	CRTB															
Initial Value	0	0	0	0	0	0	0	0	0	0	0	0	0	0	0	0
R/W	R	R	R	R	R	R	R	R	R	R	R	R	R	R	R	R

Bit	15	14	13	12	11	10	9	8	7	6	5	4	3	2	1	0
	CRTB															
Initial Value	0	0	0	0	0	0	0	0	0	0	0	0	0	0	0	0
R/W	R	R	R	R	R	R	R	R	R	R	R	R	R	R	R	R

Bit	Bit Name	Initial Value	R/W	Description
31 to 0	CRTB	All 0	R	<p>Current Transaction Byte Register</p> <p>This register indicates the remaining number of transfer bytes in the ongoing DMA transaction.</p> <p>The value of this register is decremented automatically while the DMA transaction is in process.</p> <p>The initial value of this register is loaded from the following register:</p> <p style="margin-left: 20px;">In register mode: The number of transfer bytes is loaded from the Next0/1 Register Set.</p> <p style="margin-left: 20px;">In link mode: The number of transfer bytes is loaded from the descriptor. (The descriptor read data is input to the NOTB_n register, and is loaded into the CRTB_n register when a transfer starts.)</p> <p>The value of this register is decremented when a write transfer ends.</p> <p>Read this register after DMA stops (that is, after the TACT bit in the CHSTAT_n register is cleared). (Handle the value read during DMA only as a reference value.)</p>

32B.5 Channel Register Set

32B.5.1 Channel Status Register n

32B.5.1.1 Channel Status Register ch0 [CHSTAT_0] <Address: H'424> Channel Status Register ch1 [CHSTAT_1] <Address: H'464>

Bit	31	30	29	28	27	26	25	24	23	22	21	20	19	18	17	16
	DNUM								—	—	—	—	—	SWPRQ	DMARQ M	INTM
Initial Value	0	0	0	0	0	0	0	0	0	0	0	0	0	0	0	0
R/W	R	R	R	R	R	R	R	R	R	R	R	R	R	R	R	R
Bit	15	14	13	12	11	10	9	8	7	6	5	4	3	2	1	0
	—	—	—	—	MODE	DER	DW	DL	SR	TC	END	ER	SUS	TACT	RQST	EN
Initial Value	0	0	0	0	0	0	0	0	0	0	0	0	0	0	0	0
R/W	R	R	R	R	R	R	R	R	R	R	R	R	R	R	R	R

Bit	Bit Name	Initial Value	R/W	Description
31 to 24	DNUM	All 0	R	<p>Data Number</p> <p>These bits indicate the amount of valid data in the buffer.</p> <p>The indicated amount of data is the amount of the data that was read from the source but has not yet been written to the destination. (Unit: byte)</p> <p>Incrementing condition:</p> <ul style="list-style-type: none"> • A DMA read transfer ends. <p>Decrementing condition:</p> <ul style="list-style-type: none"> • A DMA write transfer ends. <p>Clearing conditions:</p> <ul style="list-style-type: none"> • A condition for clearing the EN bit is met. • "1" is written to the SWRST bit in the CHCTRL_n register.
23 to 19	—	All 0	R	Reserved area. Write 0 to these bits. When these bits are read, 0 is read.
18	SWPRQ	0	R	<p>Sweep Request</p> <p>This bit indicates the state of sweep request.</p> <p>This bit indicates the state of software sweep request (which has been activated by the SETSSWPRQ bit in the CHCTRL_n register).</p> <p>1: The sweep request signal has been asserted.</p> <p>0: The sweep request signal has not been asserted.</p> <p>Setting condition:</p> <ul style="list-style-type: none"> • The SETSSWPRQ bit in the CHCTRL_n register is asserted. <p>Clearing conditions:</p> <ul style="list-style-type: none"> • The buffer becomes empty because of sweep. • "1" is written to the CLRHSWPRQM bit in the CHCTRL_n register. • "1" is written to the SWRST bit in the CHCTRL_n register.

Bit	Bit Name	Initial Value	R/W	Description
17	DMARQM	0	R	<p>DMAREQ Mask</p> <p>This bit indicates the state of temporary masking of the DMA transfer request from the USB control.</p> <p>1: The request is temporarily masked. 0: The request is released from temporary masking.</p> <p>Setting condition:</p> <ul style="list-style-type: none"> The SETDMARQM bit in the CHCTRL_n register is set. <p>Clearing conditions:</p> <ul style="list-style-type: none"> "1" is written to the CLRDARQM bit in the CHCTRL_n register. "1" is written to the SWRST bit in the CHCTRL_n register.
16	INTM	0	R	<p>Interrupt Mask</p> <p>This bit indicates the state of temporary masking of the output from the USBFDMAm interrupt.</p> <p>1: The output is temporarily masked. 0: The output is released from temporary masking.</p> <p>Setting condition:</p> <ul style="list-style-type: none"> "1" is written to the SETINTM bit in the CHCTRL_n register. <p>Clearing conditions:</p> <ul style="list-style-type: none"> "1" is written to the CLRINTM bit in the CHCTRL_n register. "1" is written to the SWRST bit in the CHCTRL_n register.
15 to 12	—	All 0	R	Reserved area. Write 0 to these bits. When these bits are read, 0 is read.
11	MODE	0	R	<p>DMA Mode</p> <p>This bit indicates the DMA mode. The indicated value is the value of the DMS bit in the CHCFG_n register.</p> <p>0: Register mode 1: Link mode</p>
10	DER	0	R	<p>Descriptor Error</p> <p>This bit indicates whether the data read from the descriptor is invalid (LV = 0) (regardless of the value of the DIM bit in the CHCFG_n register).</p> <p>0: No descriptor error has occurred. 1: A descriptor error has occurred.</p> <p>Setting condition:</p> <ul style="list-style-type: none"> In link mode, when the DRRP bit in the CHCFG_n register is 0, the LV bit value read from the descriptor is 0. <p>Clearing conditions:</p> <ul style="list-style-type: none"> "1" is written to the CLRDER bit in the CHCTRL_n register. "1" is written to the SWRST bit in the CHCTRL_n register.
9	DW	0	R	<p>Descriptor WriteBack</p> <p>This bit indicates whether data is being written back to the descriptor. If a bus error occurs during write-back to the descriptor, this bit retains 1.</p> <p>0: Status other than write-back to the header in link mode 1: (When the ER bit in the CHSTAT_n register is 0) Data is being written back to the header in link mode. (When the ER bit in the CHSTAT_n register is 1) A bus error has occurred during write-back to the header in link mode.</p> <p>Setting condition:</p> <ul style="list-style-type: none"> Write-back to the header is started in link mode. <p>Clearing conditions:</p> <ul style="list-style-type: none"> Write-back to the header in link mode ends with an OK response. "1" is written to the SWRST bit in the CHCTRL_n register. If the bit retains 1 because of an error response, this bit can be cleared only by setting the SWRST bit.

Bit	Bit Name	Initial Value	R/W	Description
8	DL	0	R	<p>Descriptor Load</p> <p>This bit indicates whether data is being read from the descriptor. If a bus error occurs during descriptor reading, this bit retains 1.</p> <p>0: Status other than descriptor reading 1: (When the ER bit is 0)</p> <p>Descriptor reading is in process in link mode. (When the ER bit is 1)</p> <p>A bus error has occurred during descriptor reading in link mode.</p> <p>Setting condition:</p> <ul style="list-style-type: none"> • Descriptor reading is started in link mode. <p>Clearing conditions:</p> <ul style="list-style-type: none"> • Descriptor reading in link mode ends with an OK response. • "1" is written to the SWRST bit in the CHCTRL_n register. If the bit retains 1 because of an error response, this bit can be cleared only by setting the SWRST bit.
7	SR	0	R	<p>Selected Register Set</p> <p>In register mode, this bit indicates the register set that is selected.</p> <p>0: Next0 Register Set 1: Next1 Register Set</p> <p>Setting condition:</p> <ul style="list-style-type: none"> • The RSEL bit in the CHCFG_n register is set. <p>Clearing condition:</p> <ul style="list-style-type: none"> • The RSEL bit in the CHCFG_n register is cleared.
6	TC	0	R	<p>Terminal Count</p> <p>This status bit indicates whether the DMA transaction has ended. This bit is set only when the TCM bit in the CHCFG_n register is 0.</p> <p>0: The DMA transfer has not ended. 1: The DMA transfer has ended.</p> <p>Setting conditions:</p> <ul style="list-style-type: none"> • In register mode, transfer of the total number of transfer bytes specified in the CRTB bits ends. • In link mode, when the WBD bit in the header of the descriptor is 1, transfer of the total number of transfer bytes specified in the CRTB bits ends. • In link mode, when the WBD bit in the header of the descriptor is 0, write-back to the descriptor ends. <p>Clearing conditions:</p> <ul style="list-style-type: none"> • "1" is written to the CLRTC bit in the CHCTRL_n register. • "1" is written to the SWRST bit in the CHCTRL_n register.
5	END	0	R	<p>USBFDMAmn Interrupted</p> <p>This bit indicates whether the DMA transaction has ended and an USBFDMAmn interrupt has occurred.</p> <p>0: The DMA transfer has not ended. 1: The DMA transfer has ended.</p> <p>Setting conditions:</p> <ul style="list-style-type: none"> • The condition for setting the TC bit is met, and the DEM bit in the CHCFG_n register is 0. • In link mode, when the descriptor is read, the LV bit in the header is 0, and the DRRP and DIM bits in the CHCFG_n register are 0. <p>Clearing conditions:</p> <ul style="list-style-type: none"> • "1" is written to the CLREND bit in the CHCTRL_n register. • "1" is written to the SWRST bit in the CHCTRL_n register.

Bit	Bit Name	Initial Value	R/W	Description
4	ER	0	R	<p>Error</p> <p>This bit indicates whether an error response has been received and a DMAERR interrupt has occurred during the DMA transfer.</p> <p>0: No error response has been received. 1: An error response has been received.</p> <p>Setting condition:</p> <ul style="list-style-type: none"> An error response is received in a bus cycle. <p>Clearing condition:</p> <ul style="list-style-type: none"> "1" is written to the SWRST bit in the CHCTRL_n register.
3	SUS	0	R	<p>Suspend</p> <p>This bit indicates whether the channel is suspended. For details, see Section 32B.9.13.8(2), Suspension.</p> <p>0: Channel_n is not suspended. 1: Channel_n is suspended.</p> <p>Setting condition:</p> <ul style="list-style-type: none"> "1" is written to the SETSUS bit in the CHCTRL_n register during the DMA transfer using channel_n, and, thereby, the inside of the channel is suspended. <p>Clearing conditions:</p> <ul style="list-style-type: none"> "1" is written to the CLRSUS bit in the CHCTRL_n register. "1" is written to the CLREN bit in the CHCTRL_n register. A condition for clearing the EN bit in the CHSTAT_n register.
2	TACT	0	R	<p>Transaction Active</p> <p>This bit indicates whether the DMAC is operating. This bit is used to check whether the channel is stopped fully. For details, see Section 32B.9.13.8, Transfer state.</p> <p>0: The DMA in channel_n is stopped. 1: The DMA in channel_n is operating.</p> <p>Setting condition:</p> <ul style="list-style-type: none"> "1" is written to the SETEN bit in the CHCTRL_n register (to start descriptor reading or wait for a DMA request). <p>Clearing condition:</p> <ul style="list-style-type: none"> The internal state is the idle state (the EN bit in the register has been cleared, and all transfers have ended).
1	RQST	0	R	<p>Request</p> <p>This bit indicates whether a transfer request has been received.</p> <p>0: No DMA transfer request has been received. 1: A DMA transfer request has been received.</p> <p>Setting conditions:</p> <ul style="list-style-type: none"> "1" is written to the STG bit in the CHCTRL_n register. A DMA transfer request is received from the USB control. <p>Clearing conditions:</p> <ul style="list-style-type: none"> "1" is written to the SWRST bit in the CHCTRL_n register. "1" is written to the CLRRQ bit in the CHCTRL_n register. In single transfer mode (the TM bit in the CHCFG_n register is 0), a transfer is executed on the side specified by the REQD bit in the CHCFG_n register In register mode, all DMA transactions are complete (the REN bit in the CHCFG_n register is 0). In link mode, the DMA transfer of the last descriptor (LE = 1) ends. In link mode, a DMA transfer is stopped during descriptor reading (the LV bit is 0 and the DRRP bit in the CHCFG_n register is 0). In link mode, when the DEM bit in the CHCFG_n register is 0, a DMA transaction ends. The master interface receives a bus error signal.

Bit	Bit Name	Initial Value	R/W	Description
0	EN	0	R	<p>Enable</p> <p>This bit indicates whether the operation of DMA channel n is enabled or stopped.</p> <p>0: Operation is stopped. 1: Operation is enabled.</p> <p>Setting conditions:</p> <ul style="list-style-type: none"> • “1” is written to the SETEN bit in the CHCTRL_n register. <p>Clearing conditions:</p> <ul style="list-style-type: none"> • “1” is written to the SWRST bit in the CHCTRL_n register. • “1” is written to the CLREN bit in the CHCTRL_n register. • An error response is received during transfer. • In register mode, all DMA transactions are completed (the REN bit in the CHCFG_n register is 0). • In link mode, DMA transfer of the last descriptor (the LE bit is 1) ends (if the WBD bit is 0, write- back to the descriptor ends). • In link mode, reading of a descriptor is stopped (the LV bit is 0 and the DRRP bit in the CHCFG_n register is 0).

- Note 1. When the ER bit in the CHSTAT_n register is set, treat the corresponding series of transfers as invalid transactions.
- Note 2. To interrupt a DMA transaction, mask or clear transfer requests or clear the EN bit in the CHSTAT_n register. (For the procedure to interrupt, see **Section 32B.9.13.8(3), Transfer suspension.**)
- Note 3. If the DMA transfer request from the USB control and the transfer request by software (setting the STG bit in the CHCFG_n register) are used together, the cause of activating the request that takes effect cannot be identified. Therefore, design the system so that only one type of transfer requests is used.
- Note 4. When using the transfer request by software, operate the STG bit for a new transfer request only after the DMA transfer requested last ends (after checking the end of the last DMA transfer by referencing the Current Register Set or another method).

32B.5.2 Channel Control Register n

32B.5.2.1 Channel Control Register ch0 [CHCTRL_0] <Address: H'428> Channel Control Register ch1 [CHCTRL_1] <Address: H'468>

Bit	31	30	29	28	27	26	25	24	23	22	21	20	19	18	17	16
	—	—	—	—	—	—	—	—	—	—	—	—	CLRDM ARQM	SETDM ARQM	CLRINT M	SETINT M
Initial Value	0	0	0	0	0	0	0	0	0	0	0	0	0	0	0	0
R/W	R	R	R	R	R	R	R	R	R	R	R	R	R/W	R/W	R/W	R/W
Bit	15	14	13	12	11	10	9	8	7	6	5	4	3	2	1	0
	—	SETSS WPRQ	—	SETRE N	—	—	CLRSU S	SETSU S	CLRDE R	CLRTC	CLREN D	CLRRQ	SWRST	STG	CLREN	SETEN
Initial Value	0	0	0	0	0	0	0	0	0	0	0	0	0	0	0	0
R/W	R	R/W	R	R/W	R	R	R/W	R/W	R/W	R/W	R/W	R/W	R/W	R/W	R/W	R/W

Bit	Bit Name	Initial Value	R/W	Description
31 to 20	—	All 0	R	Reserved area. Write 0 to these bits. When these bits are read, 0 is read
19	CLRDMARQM	0	R/W	<p>Clear DMAREQ Mask</p> <p>Writing 1 to this bit releases the DMA transfer requests from the USB control from temporary masking. Writing 1 to this bit also clears the DMARQM bit in the CHSTATn register.</p> <p>When this bit is read, 0 is read.</p> <p>1: Releases the DNA transfer requests from masking set by using the SETDMARQM bit.</p> <p>0: Has no effect on operation.</p>
18	SETDMARQM	0	R/W	<p>SET DMAREQ Mask</p> <p>Writing 1 to this bit temporarily masks the DMA transfer requests from the USB control. Writing 1 to this bit also sets the DMARQM bit in the CHSTATn register.</p> <p>When this bit is read, 0 is read.</p> <p>1: Masks the DMA transfer requests from the USB control.</p> <p>0: Has no effect on operation.</p>
17	CLRINTM	0	R/W	<p>Clear Interrupt Mask</p> <p>Writing 1 to this bit releases the USBFDMA_n interrupt from masking. Writing 1 to this bit also clears the INTM bit in the CHSTATn register.</p> <p>Releasing the INT_DMA[n] pin output from masking when the LVINT bit in the DCTRL register and the END bit in the CHSTAT_n register are 1 activates the INT_DMA[n] pin output. (The pin output is not activated if the LVINT bit is 0.)</p> <p>When this bit is read, 0 is read.</p> <p>1: Releases the pin output from masking set by using the SETINTM bit.</p> <p>0: Has no effect on operation.</p>
16	SETINTM	0	R/W	<p>SETINTMSet Interrupt Mask</p> <p>Writing 1 to this bit temporarily masks the USBFDMA_n interrupt. Writing 1 to this bit also sets the INTM bit in the CHSTATn register.</p> <p>When this bit is read, 0 is read.</p> <p>1: Masks the USBFDMA_n interrupt.</p> <p>0: Has no effect on operation.</p>
15	—	0	R	Reserved area. Write 0 to this bit. When this bit is read, 0 is read.

Bit	Bit Name	Initial Value	R/W	Description
14	SETSSWPR Q	0	R/W	<p>Set Software Sweep Request</p> <p>Writing 1 to this bit sweeps out the data stored in the buffer to the destination (see Section 32B.9.13.3(1), Forced software sweeping request).</p> <p>When this bit is read, 0 is read.</p> <p>1: Writes, to the destination, the data that is stored in the buffer and has not yet been written to the destination.</p> <p>0: Has no effect on operation.</p> <p>If the destination asserts a hardware request (REQD = 1), the sweep operation cannot be used.</p>
13	—	0	R	Reserved area. Write 0 to this bit. When this bit is read, 0 is read.
12	SETREN	0	R/W	<p>Set Register Set Enable</p> <p>Writing 1 to this bit sets the REN bit in the CHCFG_n register.</p> <p>When this bit is read, 0 is read.</p> <p>1: Sets the REN bit in the CHCFG_n register.</p> <p>0: Has no effect on operation.</p>
11, 10	—	All 0	R	Reserved area. Write 0 to these bits. When these bits are read, 0 is read.
9	CLRSUS	0	R/W	<p>Clear Suspend</p> <p>Writing 1 to this bit when the SUS bit in the CHSTAT_n register is 1 releases the ongoing DMA transfer from the suspended state.</p> <p>When this bit is read, 0 is read.</p> <p>1: Releases the ongoing DMA transfer from the suspended state.</p> <p>0: Has no effect on operation.</p>
8	SETSUS	0	R/W	<p>Set Suspend</p> <p>Writing 1 to this bit when the EN bit in the CHSTAT_n register is 1 suspends the ongoing DMA transfer.</p> <p>When this bit is read, 0 is read.</p> <p>1: Suspends the ongoing DMA transfer.</p> <p>0: Has no effect on operation.</p>
7	CLRDER	0	R/W	<p>Clear DER</p> <p>Writing 1 to this bit clears the DER bit in the CHSTAT_n register. Writing 1 to this bit also clear the USBFDMAmn interrupt.</p> <p>When this bit is read, 0 is read.</p> <p>1: Clears the DER bit.</p> <p>0: Has no effect on operation.</p>
6	CLRTC	0	R/W	<p>Clear TC</p> <p>Writing 1 to this bit clears the TC bit in the CHSTAT_n register.</p> <p>When this bit is read, 0 is read.</p> <p>1: Clears the TC bit.</p> <p>0: Has no effect on operation.</p>
5	CLREND	0	R/W	<p>Clear End</p> <p>Writing 1 to this bit clears the END bit in the CHSTAT_n register. Writing 1 to this bit also clear the USBFDMAmn interrupt.</p> <p>When this bit is read, 0 is read.</p> <p>1: Clears the END bit.</p> <p>0: Has no effect on operation.</p>
4	CLRRQ	0	R/W	<p>Clear Request</p> <p>Writing 1 to this bit clears the RQST bit in the CHSTAT_n register.</p> <p>When this bit is read, 0 is read.</p> <p>1: Clears the RQST bit in the CHSTAT_n register.</p> <p>0: Has no effect on operation.</p>

Bit	Bit Name	Initial Value	R/W	Description
3	SWRST	0	R/W	<p>Software Reset</p> <p>Writing 1 to this bit clears individual bits in the CHSTAT_n register (for the bits to be cleared, see the description of each bit). Setting this bit must be done when the EN and TACT bits are 0.</p> <p>When this bit is read, 0 is read.</p> <p>1: Clears individual bits in the CHSTAT_n register. 0: Has no effect on operation.</p>
2	STG	0	R/W	<p>Software Trigger</p> <p>Writing 1 to this bit makes software set an internal transfer request. If this bit and the SWRST bits are set at the same time, clearing by the SWRST bit takes priority.</p> <p>When this bit is read, 0 is read.</p> <p>1: Makes software set a transfer request (set the RQST bit in the CHSTAT_n register). 0: Has no effect on operation.</p>
1	CLREN	0	R/W	<p>Clear Enable</p> <p>Writing 1 to this bit clears the EN bit in the CHSTAT_n register (for details, see Section 32B.9.13.8(3) Transfer suspension).</p> <p>When this bit is read, 0 is read.</p> <p>1: Disables DMA transfers (clears the EN bit in the CHSTAT_n register). 0: Has no effect on operation.</p>
0	SETEN	0	R/W	<p>Set Enable</p> <p>Writing 1 to this bit enables DMA transfers in DMA channel n. If this bit and the SWRST bits are set at the same time, clearing by the SWRST bit takes priority, and DMA transfers do not start.</p> <p>When this bit is read, 0 is read.</p> <p>1: Enables DMA transfers (sets the EN bit in the CHSTAT_n register). 0: Has no effect on operation.</p>

Note: Temporary masking (using the CLRDMARQM, and SETDMARQM bits) of the DMA transfer requests from the USB control applies to only the resources for channel n. Setting the SETDMARQM bit for channel n does not affect the operation of channel m.

32B.5.3 Channel Configuration Register

32B.5.3.1 Channel Configuration Register ch0 [CHCFG_0] <Address: H'42C>

Channel Configuration Register ch1 [CHCFG_1] <Address: H'46C>

Bit	31	30	29	28	27	26	25	24	23	22	21	20	19	18	17	16
	DMS	REN	RSW	RSEL	SBE	DIM	TCM	DEM	WONLY	—	DAD	SAD	DDS			
Initial Value	0	0	0	0	0	0	0	0	0	0	0	0	0	0	0	0
R/W	R/W	R/W	R/W	R/W	R/W	R/W	R/W	R/W	R/W	R	R/W	R/W	R/W	R/W	R/W	R/W
Bit	15	14	13	12	11	10	9	8	7	6	5	4	3	2	1	0
	SDS				DRRP	—	—	—	—	—	—	—	REQD	—	—	SEL
Initial Value	0	0	0	0	0	0	0	0	0	0	0	0	0	0	0	0
R/W	R/W	R/W	R/W	R/W	R/W	R	R	R	R	R	R	R	R/W	R	R	R/W

Bit	Bit Name	Initial Value	R/W	Description
31	DMS	0	R/W	<p>DMA Mode Select</p> <p>This bit specifies the DMA mode to be used.</p> <p>0: Register mode (default)</p> <p>1: Link mode</p>
30	REN	0	R/W	<p>Register Set Enable</p> <p>This bit specifies whether to successively perform, after a DMA transaction ends, another DMA transaction using the Next Register Set selected by the RSEL bit. This bit is valid only in register mode.</p> <p>0: Does not perform the DMA transaction successively.</p> <p>1: Performs the DMA transaction successively.</p> <p>Setting conditions:</p> <ul style="list-style-type: none"> • “1” is written to this bit. • “1” is written to the SETREN bit in the CHCTRL_n register. <p>Clearing conditions:</p> <ul style="list-style-type: none"> • “0” is written to this bit. • The REN bit is 1, and a DMA transaction ends. <p>To re-set the REN bit during a transaction, we recommend you to use the SETREN bit in the CHCTRL_n register.</p>
29	RSW	0	R/W	<p>Register Select Switch</p> <p>This bit specifies whether to automatically invert the RSEL bit after a DMA transaction ends. This bit is valid only in register mode.</p> <p>0: Does not invert the RSEL bit after a DMA transaction ends. (Default)</p> <p>1: Inverts the RSEL bit after a DMA transaction ends.</p>
28	RSEL	0	R/W	<p>Register Set Select</p> <p>This bit is used to select the Next Register Set to be used for the next DMA transaction. This bit is valid only in register mode.</p> <p>When the RSW bit is 1, this bit is inverted automatically at the end of a DMA transaction.</p> <p>0: Uses the Next0 Register Set. (Default)</p> <p>1: Uses the Next1 Register Set.</p> <p>Transition condition:</p> <p>A DMA transaction ends with the RSW bit set.</p>

Bit	Bit Name	Initial Value	R/W	Description
27	SBE	0	R/W	<p>Sweep Buffer Enable</p> <p>This bit specifies whether to sweep (write) the data already read and stored in the buffer and stop transfer when the EN bit in the CHSTAT_n register is cleared during a DMA transaction.</p> <p>The sweep mode can be used only when the REQD bit is 0.</p> <p>0: Stops transfer without sweeping out the buffer. (Default)</p> <p>1: Stops transfer after sweeping out the buffer.</p>
26	DIM	0	R/W	<p>Descriptor Interrupt Mask</p> <p>This bit specifies whether to mask the USBFDMAm interrupt when the LV bit value read from descriptor header is 0.</p> <p>0: Does not mask the USBFDMAm interrupt. (Default)</p> <p>1: Mask the USBFDMAm interrupt.</p>
25	TCM	0	R/W	<p>DMATC Mask</p> <p>This bit is used to mask the DMATC signal, which is sent from the DMAC to USB control.</p> <p>When this bit is 1 at the time the DMATC signal is to be output, the DMATC signal is not asserted.</p> <p>Also, the TC bit in the CHSTAT_n register is not asserted in that case. In register mode, this bit is automatically cleared. In link mode, this bit is not cleared automatically.</p> <p>Use this bit when you control DMA transfers by software.</p> <p>0: Does not mask the DMATC signal. (Default)</p> <p>1: Masks the DMATC signal.</p> <p>Clearing condition: A DMA transaction ends with the TCM bit set.</p>
24	DEM	0	R/W	<p>USBFDMAm Mask</p> <p>When this bit is 1 at the time the USBFDMAm interrupt is not asserted. Also, the END bit in the CHSTAT_n register is not asserted in that case. In register mode, this bit is not cleared automatically. In link mode, this bit is automatically cleared.</p> <p>0: Does not mask the USBFDMAm interrupt. (Default)</p> <p>1: Masks the USBFDMAm interrupt.</p> <p>Clearing condition: A DMA transaction ends with the DEM bit set.</p>
23	WONLY	0	R/W	<p>Write Only Mode</p> <p>This bit is used to switch the transfer operation mode to the write-only mode (see Section 32B.9.12.2, Write only mode).</p> <p>0: Normal operation (default)</p> <p>1: Write-only mode</p>
22	—	0	R	Nothing is assigned to this bit. Fix this bit to 0.
21	DAD	0	R/W	<p>Destination Address Direction</p> <p>This bit specifies the direction of counting the transfer-destination address in DMA channel n. If the transfer destination is on the USB control side, write 1 (fixed) to this bit.</p> <p>0: Incrementing (default)</p> <p>1: Fixed</p> <p>When the transfer destination uses the skip mode or is beat-unaligned, do not specify 1 (fixed) in this bit.</p>
20	SAD	0	R/W	<p>Source Address Direction</p> <p>This bit specifies the direction of counting the transfer-source address in DMA channel n. If the transfer source is on the USB control side, write 1 (fixed) to this bit.</p> <p>0: Incrementing (default)</p> <p>1: Fixed</p> <p>When the transfer source uses the skip mode or is beat-unaligned, do not specify 1 (fixed) in this bit.</p>

Bit	Bit Name	Initial Value	R/W	Description
19 to 16	DDS[3:0]	All 0	R/W	<p>Destination Data Size</p> <p>These bits specify the size of DMA transfer data. When the transfer destination is on the USB control side, select the normal mode.</p> <p>Use bit 3 to switch between the normal and skip modes.</p> <p>0: Normal mode (default) 1: Skip mode</p> <p>Use bits 2 to 0 to specify the size of transfer data. (For specifiable values, see Table 32B.21.)</p> <p>000: 8 bits (default) 001: 16 bits 010: 32 bits 011: 64 bits 100: 128 bits 101: 256 bits 110: 512 bits 111: Setting prohibited</p>
15 to 12	SDS[3:0]	All 0	R/W	<p>Source Data Size</p> <p>These bits specify the size of DMA transfer data.</p> <p>Use bit 3 to switch between the normal and skip modes.</p> <p>0: Normal mode (default) 1: Skip mode</p> <p>Use bits 2 to 0 to specify the size of transfer data. (For specifiable values, see Table 32B.21.)</p> <p>000: 8 bits (default) 001: 16 bits 010: 32 bits 011: 64 bits 100: 128 bits 101: 256 bits 110: 512 bits 111: Setting prohibited</p>
11	DRRP	0	R/W	<p>Descriptor Read Repeat</p> <p>This bit switches the operation to be performed when the LV value in the header read from the descriptor is 0. (See section 32B.9.12.1(2)(a), Operation flow of link mode.)</p> <ul style="list-style-type: none"> 0: This module sets the DER bit in the CHSTAT_n register, and then stops descriptor reading. (Default) 1: This module keeps reading the same descriptor until the LV value changes to 1, and, when the LV value becomes 1, starts the DMA transfer using the values in the descriptor. The interval of descriptor reading is controlled by using the DSCITVL register.
10 to 7	—	All 0	R	Nothing is assigned to these bits. Fix these bits to 0.
6, 5	—	All 0	R	Nothing is assigned to these bits. Fix these bits to 1.
4	—	0	R	Nothing is assigned to this bit. Fix this bit to 0.
3	REQD	0	R/W	<p>Request Direction</p> <p>This bit specifies whether the USB control is on the transfer source side or it is on the transfer destination side.</p> <p>0: The USB control is on the transfer source side. (Default) 1: The USB control is on the transfer destination side.</p>
2, 1	—	All 0	R	Nothing is assigned to these bits. Fix these bits to 0.
0	SEL	0	R/W	<p>Terminal Select</p> <p>This bit selects the FIFO channel to be used on the USB control side.</p> <p>0: D0FIFO 1: D1FIFO</p>

The range of values specifiable in the SDS[2:0] and DDS[2:0] bits depends on the data bus width, number of implemented buffer stages, and whether the address to be accessed is beat-aligned or not (beat-unaligned). The table below shows the range of specifiable values.

Table 32B.21 Range of Sizes That Can Be Specified in SDS and DDS Bits

Transfer Address	REQD	SDS[2:0]	DDS[2:0]
Beat aligned	0	This data size should be equal to that of the MBW bits in the DxFIFOSEL register.	8 to 32 bits (000 to 010) 128 to 512 bits (100 to 110)
	1	8 to 32 bits (000 to 010) 128 to 512 bits (100 to 110)	This data size should be equal to that of the MBW bits in the DxFIFOSEL register.
Beat unaligned	0	This data size should be equal to that of the MBW bits in the DxFIFOSEL register.	8 to 32 bits (000 to 010) 128 to 256 bits (100 to 101)
	1	8 to 32 bits (000 to 010) 128 to 256 bits (100 to 101)	This data size should be equal to that of the MBW bits in the DxFIFOSEL register.

Note: When the destination is beat-unaligned with REQD = 0 or the source is beat-unaligned with REQD = 1, specify values in the range of specifiable values for beat-unaligned transfer addresses in both of the SDS[2:0] and DDS[2:0] bits. Even if the transfer source and destination are beat-aligned when a DMA transaction starts, they might become beat-unaligned in the middle of the transaction when a skip transfer is used. If this might occur, perform settings in the first place on the assumption that the transfer source and destination are beat-unaligned. If software cannot determine whether the transfer source and/or destination is beat-aligned, use values in the range of specifiable values for beat-unaligned transfer addresses.

32B.5.4 Channel Interval Register n

For details, see **Section 32B.9.13.6, Interval Count Function.**

32B.5.4.1 Channel Interval Register ch0 [CHITVL_0] <Address: H'430> Channel Interval Register ch1 [CHITVL_1] <Address: H'470>

Bit	31	30	29	28	27	26	25	24	23	22	21	20	19	18	17	16
	—	—	—	—	—	—	—	—	—	—	—	—	—	—	—	—
Initial Value	0	0	0	0	0	0	0	0	0	0	0	0	0	0	0	0
R/W	R	R	R	R	R	R	R	R	R	R	R	R	R	R	R	R
Bit	15	14	13	12	11	10	9	8	7	6	5	4	3	2	1	0
	ITVL															
Initial Value	0	0	0	0	0	0	0	0	0	0	0	0	0	0	0	0
R/W	R/W	R/W	R/W	R/W	R/W	R/W	R/W	R/W	R/W	R/W	R/W	R/W	R/W	R/W	R/W	R/W

Bit	Bit Name	Initial Value	R/W	Description
31 to 16	—	All 0	R	Nothing is assigned to these bits. Fix these bits to 0.
15 to 0	ITVL	All 0	R/W	Interval These bits specify the DMA transfer interval.

32B.5.5 Channel Extension Register n

32B.5.5.1 Channel Extension Register ch0 [CHEXT_0] <Address: H'434>

Channel Extension Register ch1 [CHEXT_1] <Address: H'474>

Bit	31	30	29	28	27	26	25	24	23	22	21	20	19	18	17	16
	—	—	—	—	—	—	—	—	—	—	—	—	—	—	—	—
Initial Value	0	0	0	0	0	0	0	0	0	0	0	0	0	0	0	0
	—	—	—	—	—	—	—	—	—	—	—	—	—	—	—	—
R/W	R	R	R	R	R	R	R	R	R	R	R	R	R	R	R	R
Bit	15	14	13	12	11	10	9	8	7	6	5	4	3	2	1	0
	—	—	—	—	DPR				—	—	—	—	SPR			
Initial Value	0	0	0	0	0	0	0	0	0	0	0	0	0	0	0	0
	—	—	—	—	—	—	—	—	—	—	—	—	—	—	—	—
R/W	R	R	R	R	R/W	R/W	R/W	R/W	R/W	R/W	R/W	R/W	R/W	R/W	R/W	R/W

Bit	Bit Name	Initial Value	R/W	Description
31 to 12	—	All 0	R	Nothing is assigned to these bits. Fix these bits to 0.
11 to 8	DPR	All 0	R/W	Destination PROT These bits specify the value to be output to the MHPROT[3:0] pin in a DMA write transfer. The initial value of these bits is H'0.
7 to 4	—	All 0	R/W	Nothing is assigned to these bits. Fix these bits to 0.
3 to 0	SPR	All 0	R/W	Source PROT These bits specify the value to be output to the MHPROT[3:0] pin in a DMA read transfer. The initial value of these bits is H'0.

32B.6 Link Register Set

When software sets a descriptor address in the NXLA_n register and starts the DMAC, hardware loads the value set in the NXLA_n register into the CRLA_n register. Then, the descriptor is read, and the DMAC starts a DMA transaction according to the values read from the descriptor. The value in the NXLA_n register is automatically updated to the Next Link Address value read from the descriptor, and the updated value is used as the descriptor address in the next DMA transaction.

32B.6.1 Next Link Address Register n (NXLA_n)

32B.6.1.1 Next Link Address Register ch0 [NXLA_0] <Address: H'438> Next Link Address Register ch1 [NXLA_1] <Address: H'478>

Bit	31	30	29	28	27	26	25	24	23	22	21	20	19	18	17	16
	NXLA															
Initial Value	0	0	0	0	0	0	0	0	0	0	0	0	0	0	0	0
R/W	R/W	R/W	R/W	R/W	R/W	R/W	R/W	R/W	R/W	R/W	R/W	R/W	R/W	R/W	R/W	R/W
Bit	15	14	13	12	11	10	9	8	7	6	5	4	3	2	1	0
	NXLA															
Initial Value	0	0	0	0	0	0	0	0	0	0	0	0	0	0	0	0
R/W	R/W	R/W	R/W	R/W	R/W	R/W	R/W	R/W	R/W	R/W	R/W	R/W	R/W	R/W	R	R

Bit	Bit Name	Initial Value	R/W	Description
31 to 2	NXLA	All 0	R/W	Next Link Address
1, 0		All 0	R	These bits specify the link-destination address. Upper two bits are fixed to 0, and only the address aligned with a word boundary can be set.

32B.6.2 Current Link Address Register n (CRLA_n)

32B.6.2.1 Current Link Address Register ch0 [CRLA_0] <Address: H'43C> Current Link Address Register ch1 [CRLA_1] <Address: H'47C>

Bit	31	30	29	28	27	26	25	24	23	22	21	20	19	18	17	16
	CRLA															
Initial Value	0	0	0	0	0	0	0	0	0	0	0	0	0	0	0	0
R/W	R	R	R	R	R	R	R	R	R	R	R	R	R	R	R	R
Bit	15	14	13	12	11	10	9	8	7	6	5	4	3	2	1	0
	CRLA															
Initial Value	0	0	0	0	0	0	0	0	0	0	0	0	0	0	0	0
R/W	R	R	R	R	R	R	R	R	R	R	R	R	R	R	R	R

Bit	Bit Name	Initial Value	R/W	Description
31 to 0	CRLA	All 0	R	Current Link Address These bits indicate the address of the descriptor being used for current transaction.

32B.7 Skip Register Set

This register set is used to specify settings for a skip (scatter/gather) transfer.

32B.7.1 Source Continuous Register n

32B.7.1.1 Source Continuous Register ch0 [SCNT_0] <Address: H'600> Source Continuous Register ch1 [SCNT_1] <Address: H'620>

Bit	31	30	29	28	27	26	25	24	23	22	21	20	19	18	17	16
	SCNT															
Initial Value	0	0	0	0	0	0	0	0	0	0	0	0	0	0	0	0
R/W	R/W	R/W	R/W	R/W	R/W	R/W	R/W	R/W	R/W	R/W	R/W	R/W	R/W	R/W	R/W	R/W
Bit	15	14	13	12	11	10	9	8	7	6	5	4	3	2	1	0
	SCNT															
Initial Value	0	0	0	0	0	0	0	0	0	0	0	0	0	0	0	0
R/W	R/W	R/W	R/W	R/W	R/W	R/W	R/W	R/W	R/W	R/W	R/W	R/W	R/W	R/W	R/W	R/W

Bit	Bit Name	Initial Value	R/W	Description
31 to 0	SCNT	All 0	R/W	Source Continuous These bits specify the size of the space to be accessed continuously by source address access. (Unit: byte)

Note: This register is used in pair with the SSKP_n register (see **Figure 32B.3**). To use this mode, set the SDS[3] bits in the CHCFG_n register to 1. To perform a skip transfer on the transfer source side, the SAD bit in the CHCFG_n register must not be set to 1 (Fixed). Do not perform a skip transfer with the SCNT bits set to 0.

32B.7.2 Source Skip Register n

32B.7.2.1 Source Skip Register ch0 [SSKP_0] <Address: H'604>

Source Skip Register ch1 [SSKP_1] <Address: H'624>

Bit	31	30	29	28	27	26	25	24	23	22	21	20	19	18	17	16
	SSKP															
Initial Value	0	0	0	0	0	0	0	0	0	0	0	0	0	0	0	0
R/W	R/W	R/W	R/W	R/W	R/W	R/W	R/W	R/W	R/W	R/W	R/W	R/W	R/W	R/W	R/W	R/W
Bit	15	14	13	12	11	10	9	8	7	6	5	4	3	2	1	0
	SSKP															
Initial Value	0	0	0	0	0	0	0	0	0	0	0	0	0	0	0	0
R/W	R/W	R/W	R/W	R/W	R/W	R/W	R/W	R/W	R/W	R/W	R/W	R/W	R/W	R/W	R/W	R/W

Bit	Bit Name	Initial Value	R/W	Description
31 to 0	SSKP	All 0	R/W	Source Skip These bits specify the size of area to be skipped in a source address access. (Unit: byte)

Note: This register is used in pair with the SCNT_n register (see **Figure 32B.3**). To use this mode, set the SDS[3] bits in the CHCFG_n register to 1. To perform a skip transfer on the transfer source side, the SAD bit in the CHCFG_n register must not set to 1 (Fixed).

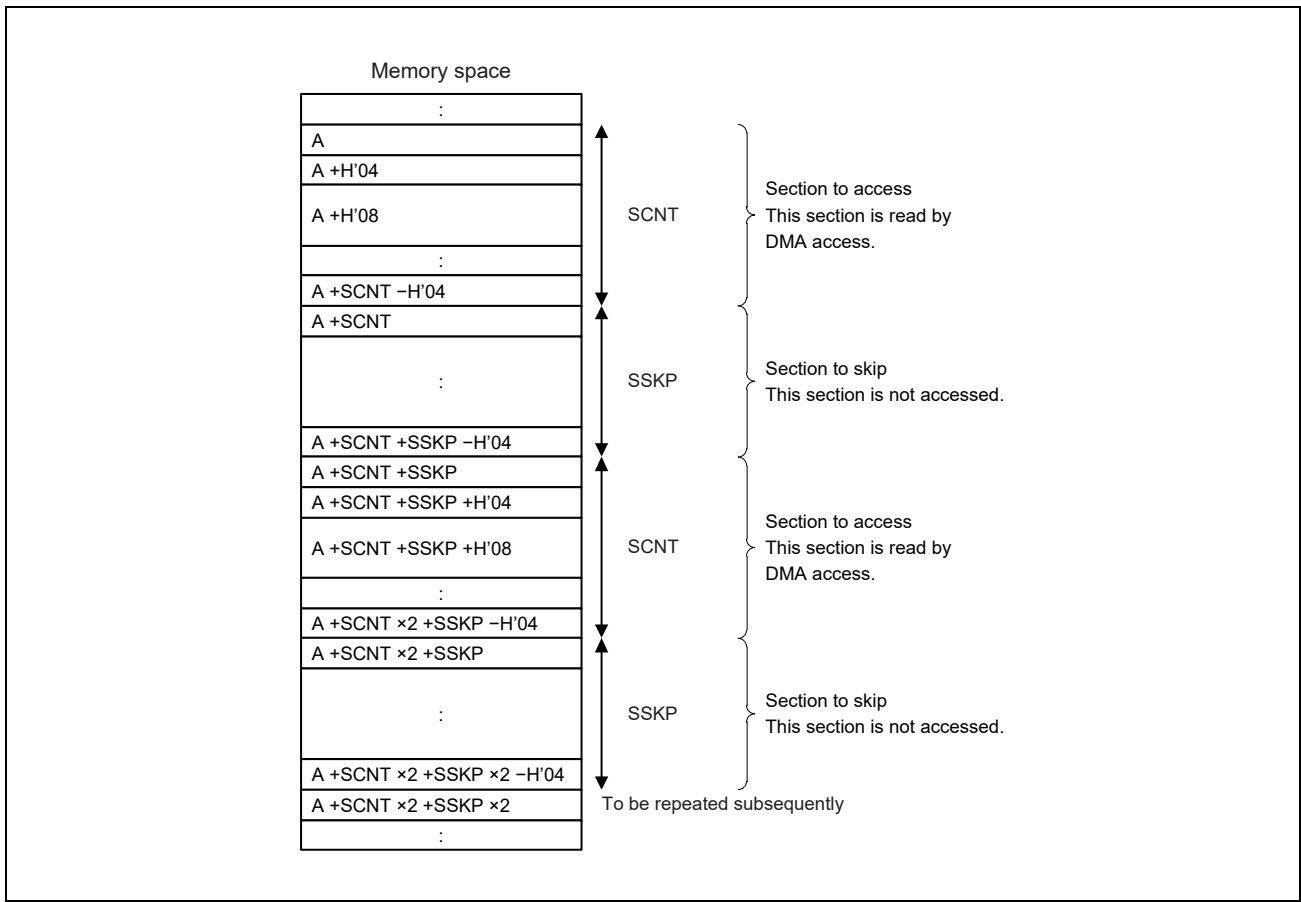

Figure 32B.3 Relationship between SSKP and SCNT

You can specify values of the SCNT and SSKP bits regardless of the source address and the value of the SDS field in the CHCFG_n register. The DMAC performs access based on the size specified in the SDS field, and fetches only valid data into the buffer (see **Section 32B.9.14.1(1), Read access**).

32B.7.3 Destination Continuous Register n

32B.7.3.1 Destination Continuous Register ch0 [DCNT_0] <Address: H'608>

Destination Continuous Register ch1 [DCNT_1] <Address: H'628>

Bit	31	30	29	28	27	26	25	24	23	22	21	20	19	18	17	16
	DCNT															
Initial Value	0	0	0	0	0	0	0	0	0	0	0	0	0	0	0	0
R/W	R/W	R/W	R/W	R/W	R/W	R/W	R/W	R/W	R/W	R/W	R/W	R/W	R/W	R/W	R/W	R/W
Bit	15	14	13	12	11	10	9	8	7	6	5	4	3	2	1	0
	DCNT															
Initial Value	0	0	0	0	0	0	0	0	0	0	0	0	0	0	0	0
R/W	R/W	R/W	R/W	R/W	R/W	R/W	R/W	R/W	R/W	R/W	R/W	R/W	R/W	R/W	R/W	R/W

Bit	Bit Name	Initial Value	R/W	Description
31 to 0	DCNT	All 0	R/W	Destination Continuous These bits specify the size of the space to be accessed continuously by destination address access. (Unit: byte)

Note: This register is used in pair with the DSKP_n register (see **Figure 32B.4**). To use this mode, set the DDS[3] bits in the CHCFG_n register to 1. To perform a skip transfer on the transfer destination side, the DAD bit in the CHCFG_n register must not be set to 1 (Fixed). Do not perform a skip transfer with the DCNT bits set to 0.

32B.7.4 Destination Skip Register n

32B.7.4.1 Destination Skip Register ch0 [DSKP_0] <Address: H'60C>

Destination Skip Register ch1 [DSKP_1] <Address: H'62C>

Bit	31	30	29	28	27	26	25	24	23	22	21	20	19	18	17	16
	DSKP															
Initial Value	0	0	0	0	0	0	0	0	0	0	0	0	0	0	0	0
R/W	R/W	R/W	R/W	R/W	R/W	R/W	R/W	R/W	R/W	R/W	R/W	R/W	R/W	R/W	R/W	R/W
Bit	15	14	13	12	11	10	9	8	7	6	5	4	3	2	1	0
	DSKP															
Initial Value	0	0	0	0	0	0	0	0	0	0	0	0	0	0	0	0
R/W	R/W	R/W	R/W	R/W	R/W	R/W	R/W	R/W	R/W	R/W	R/W	R/W	R/W	R/W	R/W	R/W

Bit	Bit Name	Initial Value	R/W	Description
31 to 0	DSKP	All 0	R/W	Destination Skip These bits specify the size of area to be skipped in a destination address access. (Unit: byte)

Note: This register is used in pair with the DCNT_n register (see **Figure 32B.4**). To use this mode, set the DDS[3] bits in the CHCFG_n register to 1. To perform a skip transfer on the transfer destination side, the DAD bit in the CHCFG_n register must not be set to 1 (Fixed).

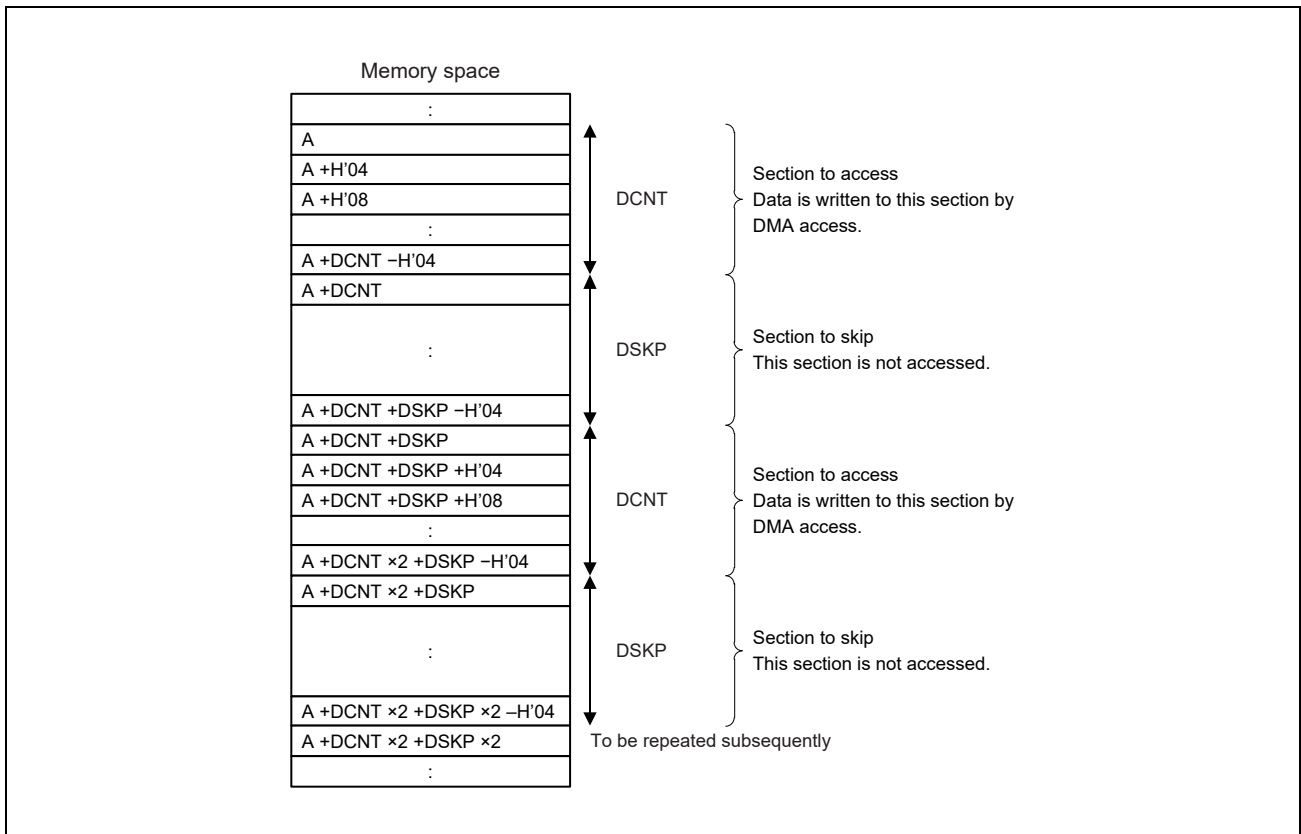

Figure 32B.4 Relationship between DSKP and DCNT

You can specify values of the DCNT and DSKP bits regardless of the destination address and the value of the DDS field in the CHCFG_n register. The DMAC performs write access to only the specified space that has a combined size not more than the size specified in the DDS field (see **Section 32B.9.14.1(1), Read access**).

32B.8 DMA Register Set

The registers described below are shared by all channels.

32B.8.1 DMA Control Register

32B.8.1.1 DMA Control Register [DCTRL] <Address: H'700>

Bit	31	30	29	28	27	26	25	24	23	22	21	20	19	18	17	16
	—	—	—	—	LWPR				—	—	—	—	LDPR			
Initial Value	0	0	0	0	0	0	0	0	0	0	0	0	0	0	0	0
	—	—	—	—	—	—	—	—	—	—	—	—	—	—	—	—
R/W	R	R	R	R	R/W	R/W	R/W	R/W	R	R	R	R	R/W	R/W	R/W	R/W
Bit	15	14	13	12	11	10	9	8	7	6	5	4	3	2	1	0
	—	—	—	—	—	—	—	—	—	—	—	—	—	—	LVINT	PR
Initial Value	0	0	0	0	0	0	0	0	0	0	0	0	0	0	0	0
	—	—	—	—	—	—	—	—	—	—	—	—	—	—	—	—
R/W	R	R	R	R	R	R	R	R	R	R	R	R	R	R	R/W	R/W

Bit	Bit Name	Initial Value	R/W	Description
31 to 28	—	All 0	R	Nothing is assigned to these bits. Fix these bits to 0.
27 to 24	LWPR	All 0	R/W	Link WriteBack PROT These bits specify the value to be output to the MHPROT[3:0] pin at write-back to the descriptor in link mode.
23 to 20	—	All 0	R	Nothing is assigned to these bits. Fix these bits to 0.
19 to 16	LDPR	All 0	R/W	Link Descriptor PROT These bits specify the value to be output to the MHPROT[3:0] pin at reading of the descriptor in link mode.
15 to 2	—	All 0	R	Nothing is assigned to these bits. Fix these bits to 0.
1	LVINT	0	R/W	Level Interrupt To use this module, be sure to set this bit to 1.
0	PR	0	R/W	Priority This bit specifies the transfer priority control mode (see Section 32B.9.13.2, DMA channel priority control). 0: Fixed priority mode 1: Round-robin mode

32B.8.2 Descriptor Interval Register n

32B.8.2.1 Descriptor Interval Register [DSCITVL] <Address: H'704>

Bit	31	30	29	28	27	26	25	24	23	22	21	20	19	18	17	16
	—	—	—	—	—	—	—	—	—	—	—	—	—	—	—	—
Initial Value	0	0	0	0	0	0	0	0	0	0	0	0	0	0	0	0
R/W	R	R	R	R	R	R	R	R	R	R	R	R	R	R	R	R
Bit	15	14	13	12	11	10	9	8	7	6	5	4	3	2	1	0
	DITVL								—	—	—	—	—	—	—	—
Initial Value	0	0	0	0	0	0	0	0	0	0	0	0	0	0	0	0
R/W	R/W	R/W	R/W	R/W	R/W	R/W	R/W	R/W	R	R	R	R	R	R	R	R

Bit	Bit Name	Initial Value	R/W	Description
31 to 16	—	All 0	R	Nothing is assigned to these bits. Fix these bits to 0.
15 to 8	DITVL	All 0	R/W	Descriptor Interval These bits specify the interval of descriptor read operation. The descriptor will be re-read at intervals of "value of DITVL x 256."
7 to 0	—	All 0	R	Nothing is assigned to these bits. Fix these bits to 0.

32B.8.3 DMA Control Register

32B.8.3.1 DMA Status EN Register [DSTAT_EN] <Address: H'710>

Bit	31	30	29	28	27	26	25	24	23	22	21	20	19	18	17	16
	—	—	—	—	—	—	—	—	—	—	—	—	—	—	—	—
Initial Value	0	0	0	0	0	0	0	0	0	0	0	0	0	0	0	0
R/W	R	R	R	R	R	R	R	R	R	R	R	R	R	R	R	R
Bit	15	14	13	12	11	10	9	8	7	6	5	4	3	2	1	0
	—	—	—	—	—	—	—	—	—	—	—	—	—	—	EN1	EN0
Initial Value	0	0	0	0	0	0	0	0	0	0	0	0	0	0	0	0
R/W	R	R	R	R	R	R	R	R	R	R	R	R	R	R	R	R

Bit	Bit Name	Initial Value	R/W	Description
31 to 2	—	All 0	R	Nothing is assigned to these bits. Fix these bits to 0.
1	EN1	0	R	This bit indicates the state of the EN bit for DMA channel 1.
0	EN0	0	R	This bit indicates the state of the EN bit for DMA channel 0.

32B.8.4 DMA Status ER Register

32B.8.4.1 DMA Status ER Register [DSTAT_ER] <Address: H'714>

Bit	31	30	29	28	27	26	25	24	23	22	21	20	19	18	17	16
	—	—	—	—	—	—	—	—	—	—	—	—	—	—	—	—
Initial Value	0	0	0	0	0	0	0	0	0	0	0	0	0	0	0	0
R/W	R	R	R	R	R	R	R	R	R	R	R	R	R	R	R	R
Bit	15	14	13	12	11	10	9	8	7	6	5	4	3	2	1	0
	—	—	—	—	—	—	—	—	—	—	—	—	—	—	ER1	ER0
Initial Value	0	0	0	0	0	0	0	0	0	0	0	0	0	0	0	0
R/W	R	R	R	R	R	R	R	R	R	R	R	R	R	R	R	R

Bit	Bit Name	Initial Value	R/W	Description
31 to 2	—	All 0	R	Nothing is assigned to these bits. Fix these bits to 0.
1	ER1	0	R	This bit indicates the state of the ER bit for DMA channel 1.
0	ER0	0	R	This bit indicates the state of the ER bit for DMA channel 0.

32B.8.5 DMA Status END Register

32B.8.5.1 DMA Status END Register [DSTAT_END] <Address: H'718>

Bit	31	30	29	28	27	26	25	24	23	22	21	20	19	18	17	16
	—	—	—	—	—	—	—	—	—	—	—	—	—	—	—	—
Initial Value	0	0	0	0	0	0	0	0	0	0	0	0	0	0	0	0
R/W	R	R	R	R	R	R	R	R	R	R	R	R	R	R	R	R
Bit	15	14	13	12	11	10	9	8	7	6	5	4	3	2	1	0
	—	—	—	—	—	—	—	—	—	—	—	—	—	—	END1	END0
Initial Value	0	0	0	0	0	0	0	0	0	0	0	0	0	0	0	0
R/W	R	R	R	R	R	R	R	R	R	R	R	R	R	R	R	R

Bit	Bit Name	Initial Value	R/W	Description
31 to 2	—	All 0	R	Nothing is assigned to these bits. Fix these bits to 0.
1	END1	0	R	This bit indicates the state of the END bit for DMA channel 1.
0	END0	0	R	This bit indicates the state of the END bit for DMA channel 0.

32B.8.6 DMA Status TC Register

32B.8.6.1 DMA Status TC Register [DSTAT_TC] <Address: H'71C>

Bit	31	30	29	28	27	26	25	24	23	22	21	20	19	18	17	16
	—	—	—	—	—	—	—	—	—	—	—	—	—	—	—	—
Initial Value	0	0	0	0	0	0	0	0	0	0	0	0	0	0	0	0
R/W	R	R	R	R	R	R	R	R	R	R	R	R	R	R	R	R
Bit	15	14	13	12	11	10	9	8	7	6	5	4	3	2	1	0
	—	—	—	—	—	—	—	—	—	—	—	—	—	—	TC1	TC0
Initial Value	0	0	0	0	0	0	0	0	0	0	0	0	0	0	0	0
R/W	R	R	R	R	R	R	R	R	R	R	R	R	R	R	R	R

Bit	Bit Name	Initial Value	R/W	Description
31 to 2	—	All 0	R	Nothing is assigned to these bits. Fix these bits to 0.
1	TC1	0	R	This bit indicates the state of the TC bit for DMA channel 1.
0	TC0	0	R	This bit indicates the state of the TC bit for DMA channel 0.

32B.8.7 DMA Status SUS Register

32B.8.7.1 DMA Status SUS Register [DSTAT_SUS] <Address: H'720>

Bit	31	30	29	28	27	26	25	24	23	22	21	20	19	18	17	16
	—	—	—	—	—	—	—	—	—	—	—	—	—	—	—	—
Initial Value	0	0	0	0	0	0	0	0	0	0	0	0	0	0	0	0
R/W	R	R	R	R	R	R	R	R	R	R	R	R	R	R	R	R
Bit	15	14	13	12	11	10	9	8	7	6	5	4	3	2	1	0
	—	—	—	—	—	—	—	—	—	—	—	—	—	—	TC1	TC0
Initial Value	0	0	0	0	0	0	0	0	0	0	0	0	0	0	0	0
R/W	R	R	R	R	R	R	R	R	R	R	R	R	R	R	R	R

Bit	Bit Name	Initial Value	R/W	Description
31 to 2	—	All 0	R	Nothing is assigned to these bits. Fix these bits to 0.
1	SUS1	0	R	This bit indicates the state of the SUS bit for DMA channel 1.
0	SUS0	0	R	This bit indicates the state of the SUS bit for DMA channel 0.

32B.9 Functions

32B.9.1 System Control and Oscillation Control

This chapter describes register manipulations required to perform initial setup of this module. This chapter also describes the registers required to control power consumption.

For the parts of the sequence that are required in both host and peripheral modes, see **Section 32A.9.1, Host/Peripheral Common Setting Sequence**.

32B.9.1.1 USB data bus resistor control

This module controls switchover between the pull-up resistors for the D+ signal and the pull-down resistors for the D- signal of the USBPHY. Use the DPRPU bit and DRPD bit in the SYSCFG0 register to set pull-up or pull-down of each signal.

Recognize that a connection to the USB host is established, and then set 1 for the DPRPU bit in the SYSCFG0 register to pull up the D+ signal.

After connected to the host, this module automatically switches the resistor when the state changes to reset handshake, suspend, or resume.

If 0 is set for the DPRPU bit in the SYSCFG0 register during communication with the host, the pull-up resistor (or termination resistor) for the USB data line is disabled. This can notify the host controller of disconnection of a device.

32B.9.2 Interrupt Function

32B.9.2.1 Overview of Interrupt Function (other than DMA Master)

The following shows a list of interrupt functions of this module. An interrupt is notified as U2P_IXL_INT. Check the status register to identify the interrupt factor. The interrupt from this module is not asserted when the supply of the internal bus clock (P1 ϕ) is stopped.

Table 32B.22 List of Interrupt functions

Bit	Interrupt name	Interrupt factor	Related status
VBINT	VBUS interrupt	The status change of the VBUS input pin is detected. (Changes from L to H and from H to L are detected.)	VBSTS
RESM	Resume interrupt	In the suspended state, a change of the USB bus status is detected (from J-State to K-State or from J-State to SE0).	—
SOFR	Frame number update interrupt	If SOFRM is 0: An SOF packet with a different frame number is received. If SOFRM is 1: An SOF with μ frame number 0 cannot be received due to a problem such as packet corruption.	—
DVST	Device state transition interrupt	A transition of a device state is detected. USB bus reset detected Suspended state detected Set Address request received Set Configuration request received	DVSQ
CTRT	Control transfer stage transition interrupt	A transition of a control transfer stage is detected. Setup stage completed ControlWrite transfer status stage transition ControlRead transfer status stage transition Control transfer completed Control transfer sequence error	CTSQ
BEMP	Buffer empty interrupt	All data in the buffer memory is sent and the buffer becomes empty. A packet exceeding the maximum packet size is received.	PIPEBEMP
NRDY	Buffer not ready interrupt	A token is received when the PID setting is BUF and the buffer memory is not available for sending and receiving data. A CRC error or bit stuff error occurs when data is received in isochronous transfer. An interval error occurs when data is received in isochronous transfer.	PIPENRDY
BRDY	Buffer ready interrupt	The buffer becomes ready (available for reading or writing data).	PIPEBRDY

The following shows the relationship between interrupts of this module.

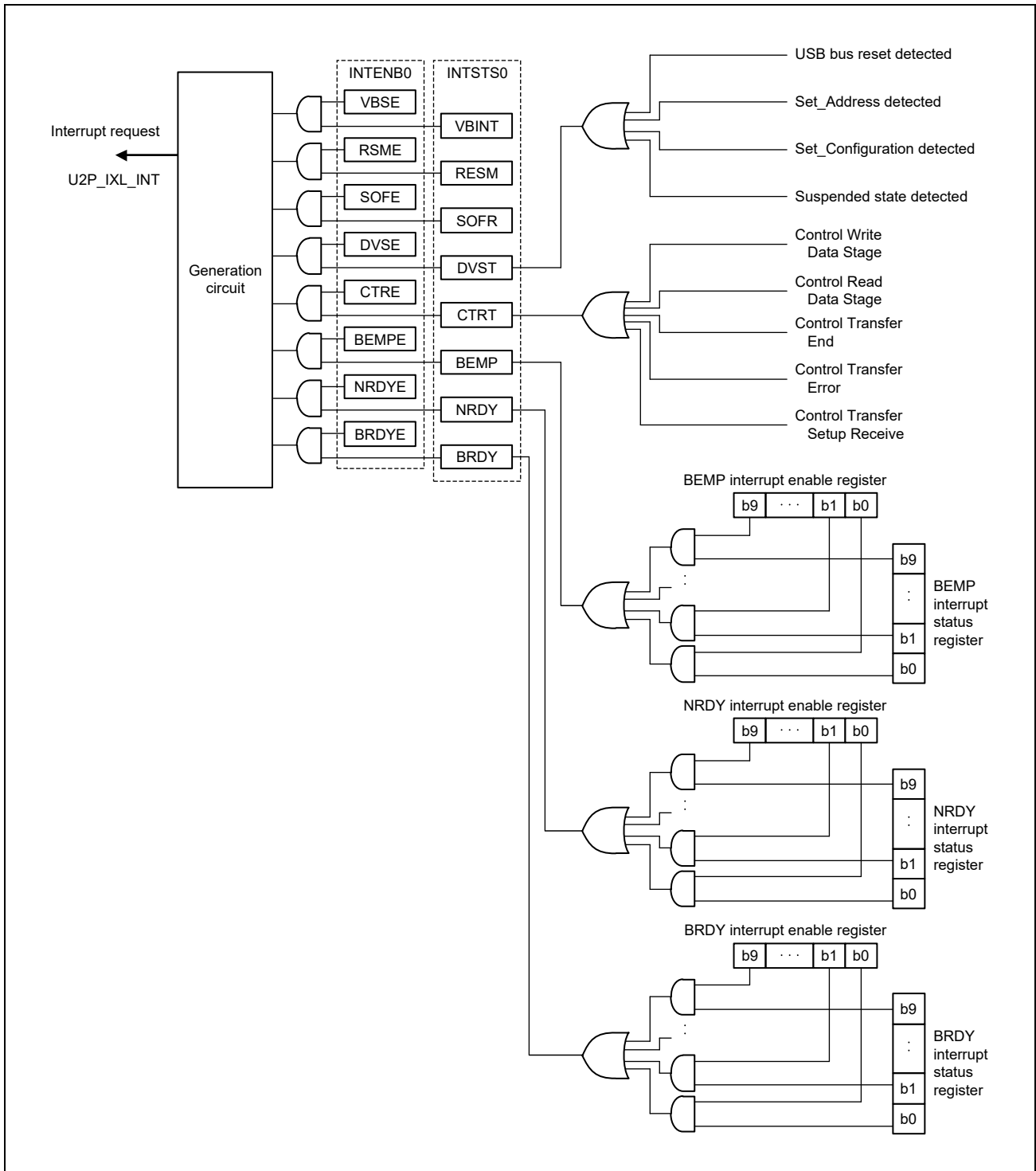

Figure 32B.5 Interrupt Association Diagram

32B.9.2.2 Device State Transition Interrupts

Figure 32B.6 shows the device state transition diagram of this module.

This module manages device states and generates device state transition interrupts. However, resumption from the suspended state (resume signal detection) is detected by a resume interrupt.

Device state transition interrupts can be enabled and prohibited by using the INTENB0 register. A device state for which a transition has occurred can be checked in the DVSQ bits in the INTSTS0 register.

To trigger a transition to the default state, a device state transition interrupt is generated after a reset hand-shake protocol ends.

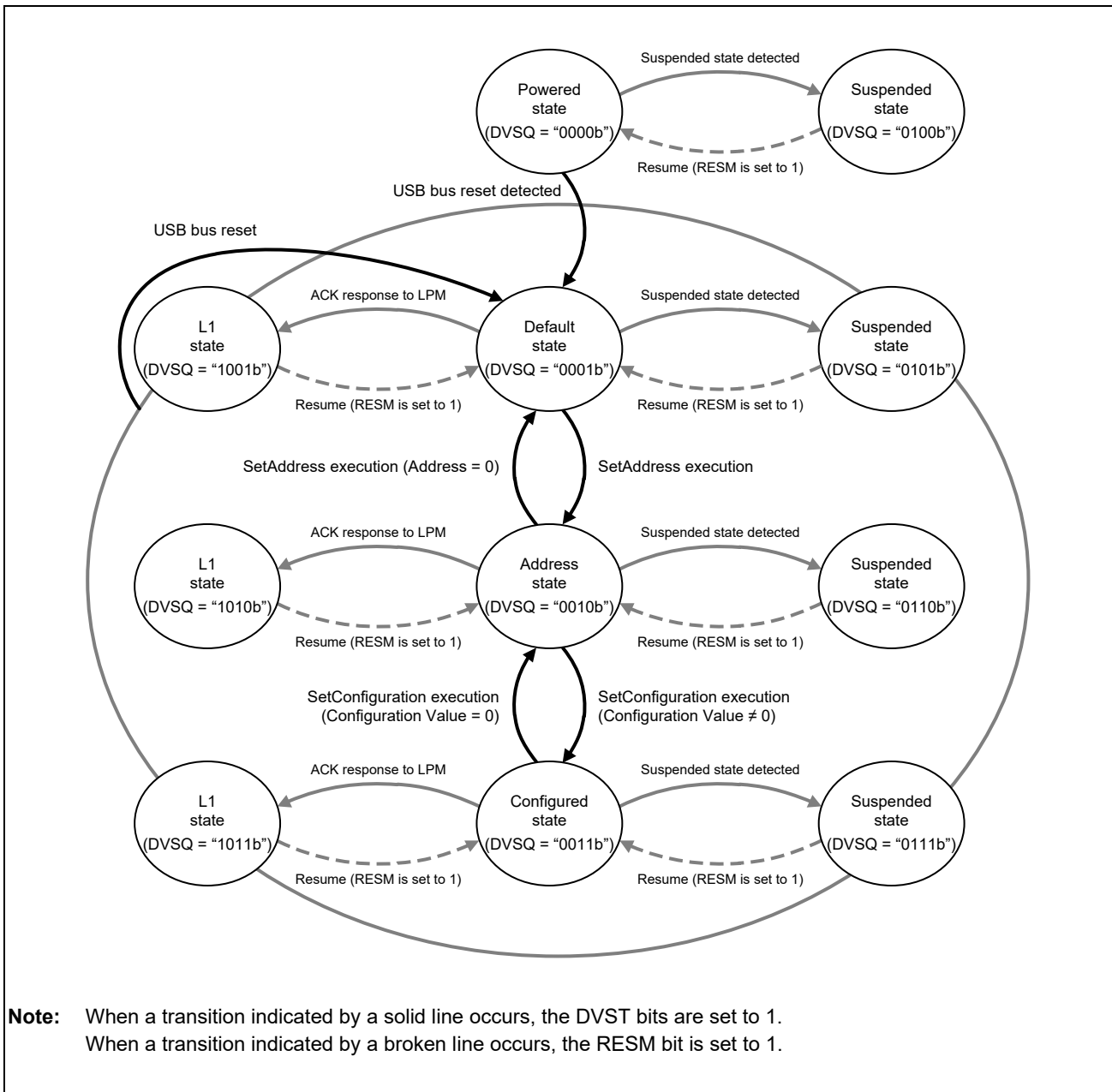

Figure 32B.6 Device State Transition Diagram

32B.9.2.3 Control Transfer Stage Transition Interrupts

Figure 32B.7 shows the control transfer stage transition diagram of this module. This module manages a sequence of control transfers, and generates a control transfer stage transition interrupt. Control transfer stage transition interrupts can be enabled and prohibited by using the INTENB0 register. A transfer stage for which a transition has occurred can be checked in the CTSQ bits in the INTSTS0 register.

The following describes sequence errors that can occur during control transfer. If an error occurs, the PID bits in the DCPCTR register are set to 1X (STALL).

(1) For Control Read transfer

- (a) An OUT or PING token is received in a situation where data has not been transferred yet for an IN token of the data stage.
- (b) An IN token is received in the status stage.
- (c) A data packet "DATAPID = DATA0" is received in the status stage.

(2) For Control Write transfer

- (a) An IN token is received in a situation where an ACK response has not been sent yet for an OUT token of the data stage.
- (b) The first data packet "DATAPID = DATA0" is received in the data stage.
- (c) An OUT or PING token is received in the status stage.

(3) For Nodata Control transfer

- (a) An OUT or PING token is received in the status stage.

If the amount of received data exceeds the value of the wLength field in a USB request in the Control Write transfer data stage, this module cannot identify this situation as a control transfer sequence error. If a packet other than a zero-length packet is received in the Control Read transfer status stage, this module sends an ACK response and then terminates processing normally.

If a CTRT interrupt is generated (SERR bit is set to 1) due to a sequence error, the CTSQ bits retain 110 until the system writes 0 to the CTRT bits to clear the interrupt status.

Therefore, as long as the CTSQ bits retain 110, even if a new USB request is received, a CTRT interrupt that reports completion of a setup stage is not generated. (Information on completion of the setup stage is retained by this module, and a CTRT interrupt is generated after the interrupt status is cleared.)

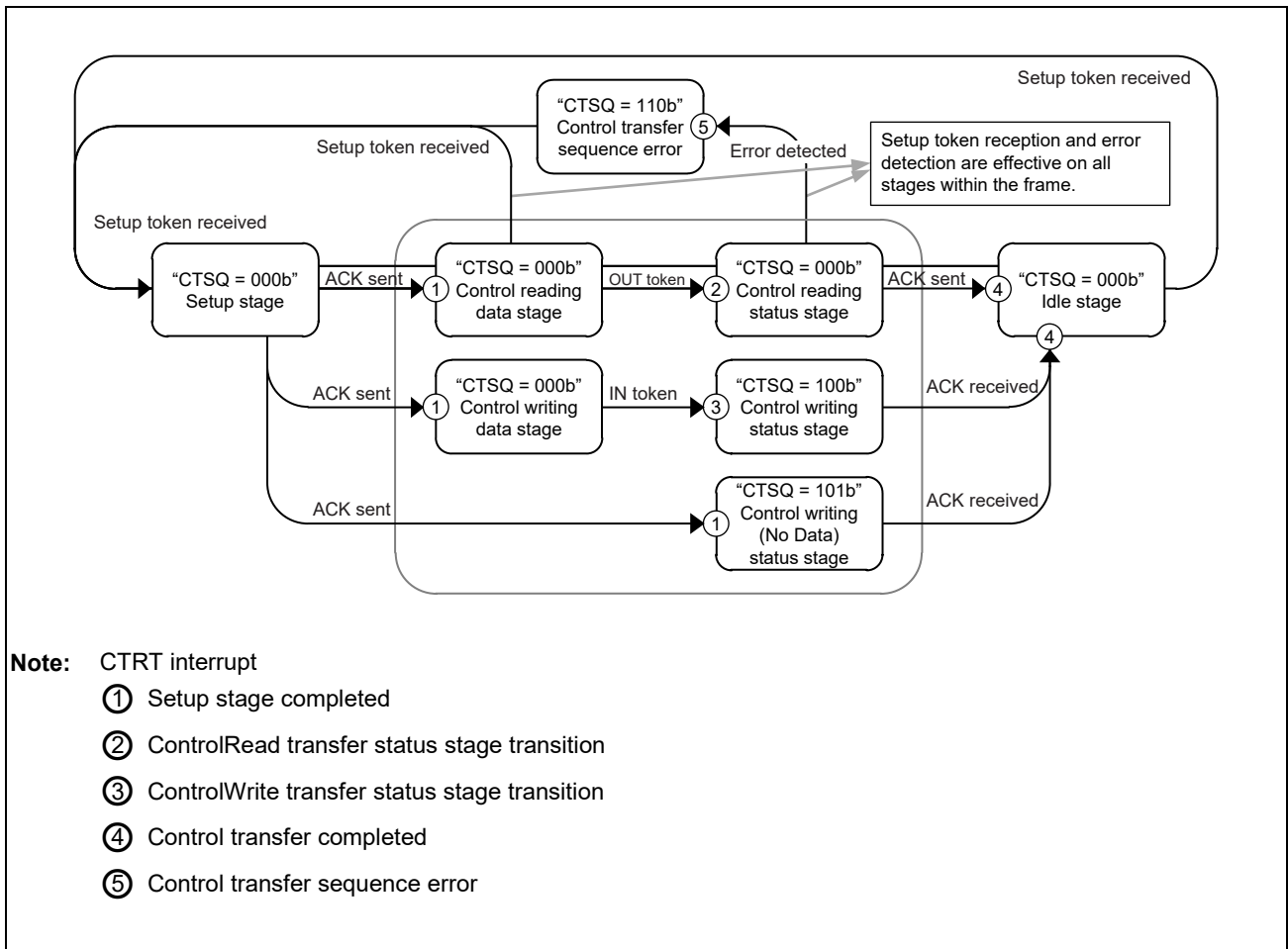

Figure 32B.7 Control Transfer Stage Transition Diagram

32B.9.2.4 Interrupts Relating to DMA Master

Table 32B.23 List of Interrupts

Interrupt Name	Interrupt Type
USBFDMAm (m, n = 0, 1)	A DMA transaction ends. An invalid descriptor is read in link mode.
USBFDMAERRm (m = 0, 1)	An error response is returned for a transfer issued by the master interface.

This module has two types of DMA interrupts USBFDMAm and USBFDMAERRm.

(1) USBFDMAm interrupt (m, n = 0, 1)

This interrupt occurs when a DMA transaction ends or when an invalid descriptor is read in link mode.

An interrupt is divided for each DMA channel. USBFDMAm0 corresponds to the interrupt for DMA 0ch, and USBFDMAm1 corresponds to the interrupt for DMA 1ch.

(2) USBFDMAERRm interrupt

This interrupt occurs when an error response is returned for a transfer issued by the master interface. This interrupt applies to all DMA channels.

USBFDMAm interrupt output can be temporarily masked by setting a register.

Interrupt detection can also be masked by setting the register. If interrupt detection is masked, the status register that indicates generation of an interrupt does not change.

On the other hand, a USBFDMAERRm interrupt signal does not have the masking function.

32B.9.3 Pipe Control

Table 32B.24 lists the pipe settings for this module. For USB data transfer, logical pipes called endpoints are used to enable data communication. This module provides 16 pipes for data transfer. Set each pipe according to the specification of the system.

Table 32B.24 PIPE Settings

Register Name	Bit Name	Setting	Comment
DCPCFG	TYPE	Specifies the transfer type.	Pipes 1 to 9: Settable
PIPECFG	BFRE	Selects BRDY interrupt mode.	Pipes 1 to 5: Settable
	DBLB	Selects double-buffer configuration.	Pipes 1 to 5: Settable
	CNTMD	Selects continuous transfer or non-continuous transfer.	DCP: Settable Pipes 1, 2: Settable only in bulk transfers Pipes 3 to 5: Settable
	DIR	Selects transfer direction.	Settable to IN or OUT
	EPNUM	Endpoint number	Pipes 1 to 9: Settable Set to a value other than "0000" when a pipe is in use.
	SHTNAK	Disables pipes when transfer is completed.	DCP: Settable Pipes 1, 2: Settable only in bulk transfers Pipes 3 to 5 Settable
PIPEBUF	BUFSIZE	Buffer memory size	DCP: Unsettable (fixed to 64/256 (CNTMD = 1) bytes) Pipes 1 to 5: Settable (up to 2 Kbytes specifiable) Pipes 6 to 9: Unsettable (fixed to 64 bytes)
	BUFNMB	Buffer memory number	DCP: Unsettable (fixed to area 0 to 3 hex) Pipes 1 to 5 Settable (area 8 to 87 hex specifiable) Pipes 6 to 9: Unsettable (fixed to area 4 to 7 hex)
DCPMAXP PIPEMAXP	MXPS	Maximum packet size	Setting conforming to the USB specification.
PIPEPERI	IFIS	Buffer flush	Pipes 1, 2: Settable only in isochronous transfers Pipes 3 to 5: Unsettable Pipes 6 to 9: Unsettable
	IITV	Interval counter	Pipes 1, 2: Settable only in isochronous transfers Pipes 3 to 5: Unsettable Pipes 6 to 9: Unsettable
DCPCTR PIPEXCTR	BSTS	Buffer status	DCP state switched between receive and transmit buffer by ISEL bit
	INBUFM	IN buffer monitor	Available only for pipes 3 to 5
	ACLRM	Auto buffer clear	Pipes 1 to 9: Settable
	SQCLR	Sequence clear	Clears data toggle bit.
	SQSET	Sequence set	Sets data toggle bit.
	SQMON	Sequence monitor	Monitors data toggle bit.
	PBUSY	Pipe busy monitor	
PID	Response PID		
DPCPTR PIPEXCTR	ATREPM	Auto response mode	Pipes 1 to 5: Settable
PIPEXTRE	TRENB	Transaction count enable	Pipes 1 to 5: Settable
	TRCLR	Current transaction counter clear	Pipes 1 to 5: Settable
PIPEXTRN	TRNCNT	Transaction counter	Pipes 1 to 5: Settable

32B.9.3.1 Maximum packet size setting

Use the MXPS bits in the DCPMAXP and PIPEMAXP registers to specify the maximum packet size for each pipe. The default control pipe (DCP) and pipes 1 to 5 can be set to any of the maximum packet sizes defined by the USB specification. For pipes 6 to 9, 64 bytes are the upper limit of the maximum packet size. Set the maximum packet size before starting transfer (by setting "PID = BUF").

DCP: Set 64 for high-speed operation.

DCP: Set 8, 16, 32, or 64 for full-speed operation. Pipes 1 to 5: Set 512 for high-speed bulk transfer.

Pipes 1 to 5: Set 8, 16, 32, or 64 for full-speed bulk transfer.

Pipes 1, 2: Set a value from 1 to 1024 for high-speed isochronous transfer.

Pipes 1, 2: Set a value from 1 to 1023 for full-speed isochronous transfer.

Pipes 6 to 9: Set 64.

High-bandwidth transfers used for interrupt transfers and isochronous transfers are not supported.

32B.9.3.2 Response PID

Set the response PID for each pipe with the PID bits in the DCPCTR and PIPEXCTR registers.

(1) Response PID setting

The response PID specifies the response to a transaction from the host.

- a) NAK: Always sends a NAK response to a generated transaction.
- b) BUF: Responds to a transaction in accordance with the buffer memory state.
- c) STALL: Always sends a STALL response to a generated transaction.

Regardless of the value set in the PID bits, an ACK is always sent as a response to a setup transaction and a USB request is stored in corresponding registers.

This module might write data to the PID bits depending on the transaction result. This module writes data to the PID bits in the following cases:

a) NAK:

- (A) The SETUP token is received normally (for the DCP only).
- (B) If 1 is set for the SHTNAK bit in the PIPECFG register during bulk transfer, a short packet is received.
- (C) If 1 is set for the SHTNAK bit during bulk transfer, the transaction counter finishes.

b) BUF:

This module does not write "BUF".

c) STALL:

- (A) When a maximum packet size over error is detected in a received data packet
- (B) When a control transfer sequence error is detected

32B.9.3.3 Pipe control register switching procedure

The following bits in the pipe control registers can be modified only when USB transmission is disabled (PID = NAK).

Figure 32B.8 shows the procedure for changing the pipe control register state from the USB transmission enabled (PID = BUF) state.

The registered that cannot be manipulated in the USB transmission enabled (PID = BUF) state are as follows:

- (1) All bits in the DCPCFG and DCPMAXP registers
- (2) SQCLR and SQSET bits in the DCPCTR register
- (3) All bits in the PIPECFG, PIPEBUF, PIPEMAXP, and PIPEPERI registers
- (4) ATREPM, ACLRM, SQCLR, and SQSET bits in the PIPExCTR register
- (5) All bits in the PIPExTRE and PIPExTRN registers

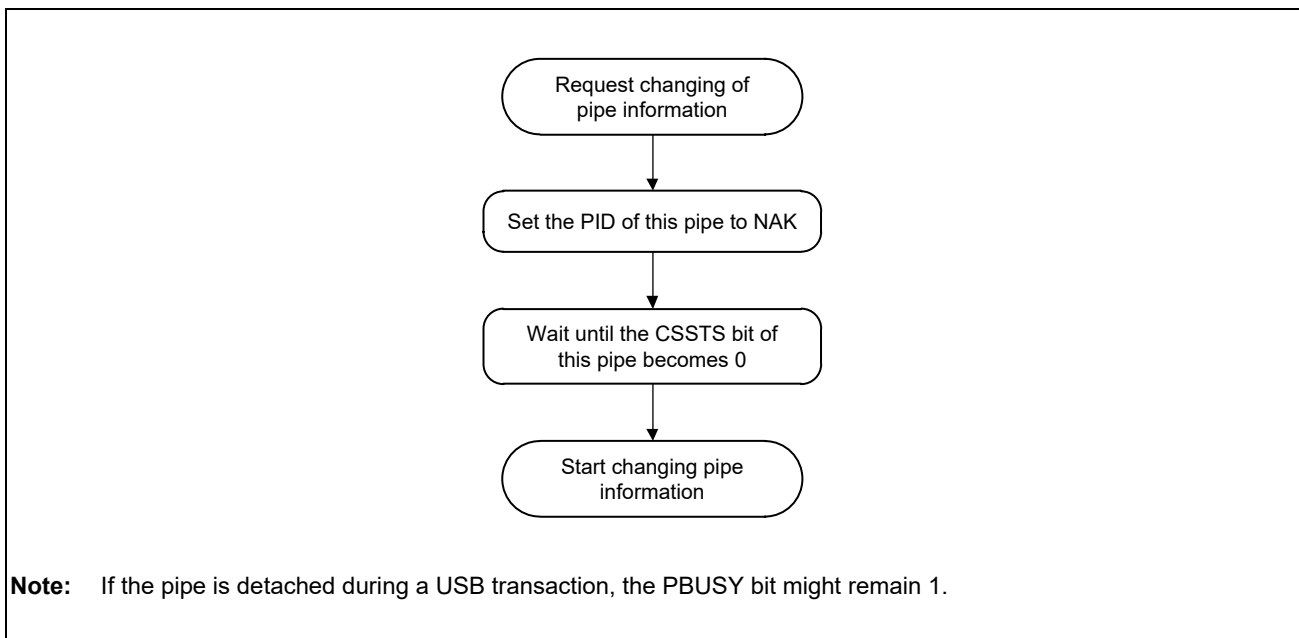

Figure 32B.8 Procedure for Changing Pipe Information from USB Transmission Enabled (PID = BUF) State

In addition, for the settings of the following bits in pipe control registers, only the pipe information that is not set for the CURPIPE bit in the CPU, DMA0, or DMA1 FIFO port can be changed.

Registers that cannot be set with pipe information that is set for the CURPIPE bit in a FIFO port:

- (6) All bits in the DCPCFG and DCPMAXP registers
- (7) All bits in the PIPECFG, PIPEBUF, PIPEMAXP, and PIPEPERI registers
- (8) ACLRM bit in the PIPExCTR register

If you change the pipe information, make sure that the setting of CURPIPE is different from the new pipe number. For the default control pipe (DCP), after modifying the pipe information, use the BCLR bit to clear the buffer.

32B.9.3.4 Data PID sequence bit

When a normal data transfer is performed during bulk transfer or interrupt transfer, or in the data stage of control transfer, this module automatically toggles the sequence bit of a data PID. The sequence bit of the next data PID to be transferred can be confirmed with the SQMON bit in the DCPCTR or PIPEXCTR registers. For data transmission, the sequence bit is switched when an ACK handshake is received. For data reception, the sequence bit is switched when an ACK handshake is sent. The data PID sequence bit can be changed by using the SQCLR and SQSET bits in the DCPCTR and PIPEXCTR registers.

During control transfer, this module automatically sets the sequence bit when the stage changes. When the setup stage finishes, the data PID is set to DATA1. In the status stage, this module responds with “PID = DATA1” without referencing the sequence bit.

Note that, the data PID sequence bit must set, when a clear feature request is sent or received.

Also note that for isochronous transfer setting pipes, you cannot use the SQSET bit to manipulate the sequence bit.

32B.9.4 FIFO Buffer

This section describes the processing related to the FIFO buffer of this module.

32B.9.4.1 FIFO buffer allocation

Figure 32B.9 shows an example of FIFO buffer memory mapping of this module. The FIFO buffer area is shared by the CPU and this module. The FIFO buffers can be accessed by either the system (CPU) or this module (SIE).

An independent FIFO buffer area is allocated for each pipe. The memory area is made up of memory blocks (1 block = 64 bytes) and is specified by the starting block number and the number of blocks (specified by the BUFNMB and BUFSIZE bits in the PIPEBUF register). When the CNTMD bit in the PIPECFG register is used to set "continuous transfer mode", the value set with the BUFSIZE bit must be an integral multiple of the maximum packet size. If the double-buffer configuration is selected by the DBLB bit in the PIPECFG register, two memory areas the size of which is specified by the BUFSIZE bit in the PIPEBUF register are allocated to a single pipe.

FIFO ports are used to access the FIFO buffer (data read/write). The pipe number of a pipe to be assigned to a FIFO port is specified by the CURPIPE bits in the CFIFOSEL/DxFIFOSEL register.

The FIFO buffer status of each pipe can be confirmed by using the BSTS and INBUFM bits in the DCPCTR and PIPEXCTR registers. The access right of a FIFO port can be confirmed by using the FRDY bit in the CFIFOCTR/DxFIFOCTR register.

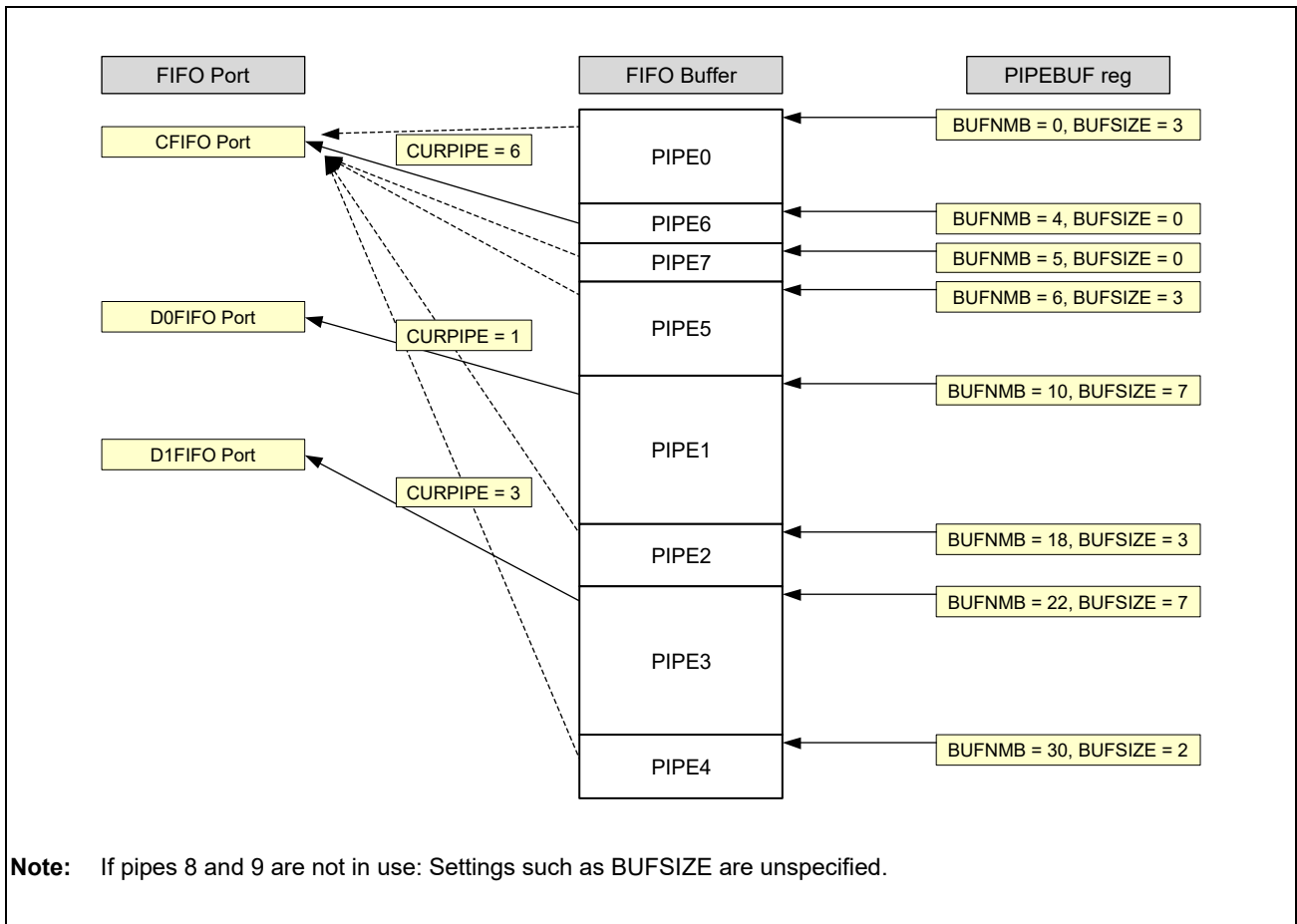

Figure 32B.9 Example of FIFO Buffer Memory Mapping

32B.9.4.2 Clearing FIFO buffers

Table 32B.25 lists the modes in which this module can clear the FIFO buffer. Clearing of the FIFO buffer is controlled by the following bits.

Table 32B.25 List of FIFO Buffer Clearing Modes

Bit Name	BCLR	DCLRM	ACLRM
Register	CFIFOCTR register DxFIFOCTR register	DxFIFOSEL register	PIPEXCTR register
Function	The FIFO buffer on the CPU side is cleared.	The FIFO buffer is automatically cleared after the data is read from the specified pipe.	The buffer is automatically cleared to discard all the received packets.
Clearing method	Write "1" to clear.	1: Mode enabled 0: Mode disabled	1: Mode enabled 0: Mode disabled

32B.9.5 FIFO Port Functions

This section describes FIFO port functions. **Table 32B.26** shows the FIFO port function settings for this module.

If data write access is enabled and data is written up to buffer full state (in non-continuous transfer: maximum packet size), the port automatically goes to the USB bus transmittable state. To enable transmission of data smaller than the buffer full (in non-continuous transfer: less than the maximum packet size), the BVAL bit in the CFIFOCTR/DxFIFOCTR register must be used to set write end.

To send a zero-length packet, the BCLR bit of that register must be used to clear the buffer before the BVAL bit is used to write end.

When all the data is read in a read access, the port automatically enters the state in which new packets can be received. However, when a zero-length packet is received (DTLN = 0), no data can be read, and therefore the buffer must be cleared by using the BCLR bit.

The receive data length is confirmed with the DTLN bits in the CFIFOCTR/DxFIFOCTR register.

Table 32B.26 FIFO Port Function Settings

Register Name	Bit Name	Function	Note
C/DxFIFOSEL	RCNT	Selects DTLN read mode	
	REW	Rewinds buffer memory (re-read, re-write)	
	DCLRM	Reads received data of the specified pipe, and then automatically clears the received data	DxFIFO only
	DREQE	Asserts DREQ signal	DxFIFO only
	MBW	Specifies FIFO port access bit width	
	BIGEND	Selects FIFO port endian	CFIFO only
	ISEL	Specifies FIFO port access direction	DxCP only
	CURPIPE	Selects current pipe	
C/DxFIFOCTR	BVAL	Finishes buffer memory write	
	BCLR	Clears CPU-side buffer memory	
	FRDY	Monitors FIFO port ready	
	DTLN	Confirms received data length	

32B.9.5.1 FIFO port selection

Table 32B.27 lists pipes that can be selected for each FIFO port.

Use the CURPIPE bits in the C/DxFIFOSEL register to select the pipe to be accessed. After selecting the pipe, confirm that the value written to the CURPIPE bits can be read correctly (if the previous pipe number is read out, this module is currently changing the pipe), confirm that FRDY = 1, and then access the FIFO port.

Figure 32B.10 shows the procedure for switching the pipe when accessing a FIFO port.

In addition, use the MBW bit to select the bus width with which to access the FIFO port. If the target pipe is the default control pipe (DCP), the ISEL bit determines the buffer memory access direction. If the target pipe is not the DCP, the DIR bit in the PIPEXCFG register determines the buffer memory access direction.

Table 32B.27 FIFO Port Access for Each Pipe

Pipe	Access Method	Usable Port
DCP	CPU access	CFIFO port register
Pipes 1 to 9	CPU access	CFIFO port register
	DMA access	DxFIFO port register

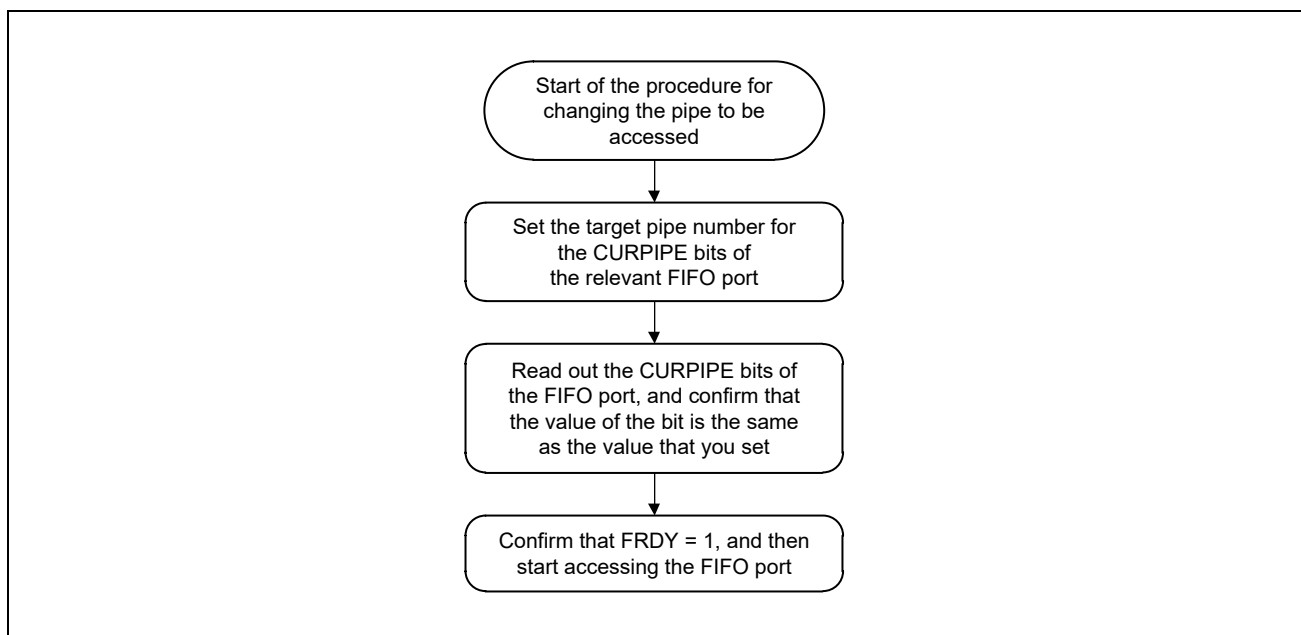

Figure 32B.10 Pipe Switching Procedure for FIFO Port Access

32B.9.5.2 DxFIFO automatic clear mode (DxFIFO port read direction)

This module automatically clears the buffer memory for a pipe when data is read out from the buffer memory if the DCLRM bit in the DxFIFOSEL register is set to 1.

Table 32B.28 shows the correspondence between packet reception and buffer memory clear processing by the software for each setting.

As shown in **Table 32B.28**, the buffer clearing conditions vary with the value that is set for the BFRE bit. However, using the DCLRM bit eliminates the need for buffer clear by the software even in states where clearing is required, which enables DMA transfers without using the software.

Note that for this function, only the buffer memory read direction can be set.

Table 32B.28 Relationship between Packet Reception and Buffer Memory Clear Processing by the Software

Buffer State during Packet Reception	Register Setting			
	DCLRM = 0		DCLRM = 1	
	BFRE = 0	BFRE = 1	BFRE = 0	BFRE = 1
Buffer full	Clearing unnecessary		Clearing unnecessary	
Zero-length packet received	Clearing necessary			
Normal short packet received	Clearing unnecessary	Clearing necessary		
Transaction count end				

32B.9.5.3 BRDY interrupt timing selection function

The BFRE bit in the PIPECFG register can be set so that a BRDY interrupt is not generated when a data packet of maximum packet size is received.

When using a DMA transfer, this function enables an interrupt to be generated only when the last data is received. The “last data” here indicates either a short packet reception or the transaction count end. If the BFRE bit is set to 1, a BRDY interrupt is generated after the received data is read. By reading the DTLN bits in the DxFIFOCTR register, the receive data length of last data packet received just before the BRDY interrupt is generated can be confirmed.

Table 32B.29 shows when this module generates a BRDY interrupt.

Table 32B.29 BRDY Interrupt Generation Timing

Buffer State during Packet Reception	Register Setting	
	BFRE = 0	BFRE = 1
Buffer full (normal packet received)	When packet is received	No interrupt generated
Zero-length packet received	When packet is received	When packet is received
Normal short packet received	When packet is received	When received data has been read from the buffer memory
Transaction count end	When packet is received	When received data has been read from the buffer memory

The BFRE bit function is valid only in the reading direction from the buffer memory. For the writing direction, fix the BFRE bit to 0.

32B.9.6 Control Transfer (DCP)

In the data stage of control transfer, the default control pipe (DCP) is used to transfer data. For the DCP, a single 64-byte buffer is allocated as a fixed area that is used for both control reading and writing (in continuous transfer mode (CNTMD = 1), the size of this area is fixed to 256 bytes). The buffer memory can be accessed through the CFIFO port only.

32B.9.6.1 Control transfer

(1) Setup stage

This module always responds with ACK to any normal setup packet for this module. The following shows the behavior of this module in the setup stage:

1. When this module receives a new setup packet, this module sets the following bits:
 - (a) VALID bit in the INTSTS0 register: 1
 - (b) PID bit in the DCPCTR register: NAK
 - (c) CCPL bit in the DCPCTR register: 0
2. When this module receives a data packet after receiving a setup packet, this module stores USB request parameters in the USBREQ, USBVAL, USBINDX, and USBLENG registers.

Response processing for control transfer must be performed after VALID is set to 0. While VALID is 1, PID cannot be set to BUF, and therefore the data stage cannot end.

By using a function of the VALID bit, when this module receives a new USB request during control transfer, this module can respond to the newest request, canceling the request that is being processed.

This module also automatically recognizes the type of transfer (ControlRead, ControlWrite, or NodataControl) from the direction bit (bit 8 of bmRequestType) and request data length (wLength) of the received USB request to manage stage transition. For an incorrect sequence, a control transfer stage transition interrupt occurs to report a sequence error to software. For details about stage management by this module, see **Figure 32B.7**.

(2) Data stage

Use the DCP to transfer data in response to the received USB request. Before the DCP buffer memory is accessed, use the ISEL bit in the CFIFOSEL register to specify the access direction.

A transaction is executed by setting the PID bit in the DCPCTR register to BUF.

The end of data transfer is detected with a BRDY or BEMP interrupt. For ControlWrite transfer, use a BRDY interrupt. For ControlRead transfer, use a BEMP interrupt.

For ControlWrite transfer in high-speed operation mode, an NYET handshake response is performed in accordance with the buffer memory state.

(3) Status stage

If the PID bit in the DCPCTR register is BUF, setting the CCPL bit to 1 terminates control transfer.

After control transfer is terminated by the above setting, this module automatically executes the status stage according to the data transfer direction determined in the setup stage, as shown below:

(a) For ControlRead transfer

Upon receiving a zero-length packet from the USB Host Controller, this module sends an ACK response.

(b) For ControlWrite or NodataControl transfer

This module sends a zero-length packet, and then receives an ACK response from the USB Host Controller.

(4) Control transfer automatic response function

This module automatically responds to any normal SET_ADDRESS request. However, if a SET_ADDRESS request has any of the following errors, software must respond, instead of this module:

- (a) bmRequestType ≠ "H'00"
- (b) wIndex ≠ "H'00"
- (c) wLength ≠ "H'00"
- (d) wValue > "H'7F"
- (e) DVSQ = "011 (Configured) "

Software must respond to all requests other than SET_ADDRESS.

32B.9.7 Bulk Transfer (Pipes 1 to 5)

The user can select the buffer memory usage method (single/double buffer, continuous/non-continuous transfer mode) for bulk transfers. The buffer memory size can be set up to 2 KB. The controller manages the buffer memory state and automatically responds to PING packets and NYET handshakes.

32B.9.7.1 NYET handshake control

Table 32B.30 lists responses to tokens received in a bulk or control transfer.

When an OUT token is received in a bulk or control transfer and there is only an open space for one packet in the buffer memory, this module sends a NYET response. However, when a short packet is received, this module sends an ACK response instead of a NYET response even under these conditions.

Table 32B.30 List of Responses to Received Tokens

PID bit value	Buffer memory state*1	Received token	Response	Note
NAK/STALL	—	SETUP	ACK	—
	—	IN/OUT/PING	NAK/STALL	—
BUF	—	SETUP	ACK	—
	RCV-BRDY	OUT/PING	ACK	Receives data packet when OUT token is received*1
	RCV-BRDY	OUT	NYET	Receives data packet*2
	RCV-BRDY	OUT (Short)	ACK	Receives data packet*2
	RCV-BRDY	PING	ACK	*2
	RCV-NRDY	OUT/PING	NAK	
	TRN-BRDY	IN	DATA0/1	Sends data packet
TRN-NRDY	IN	NAK		

Note: Details are described below.

RCV-BRDY*1: Buffer memory has a space for 2 packets or more when an OUT or PING token is received.

RCV-BRDY*2: Buffer memory has only a space for one packet when an OUT token is received.

RCV-NRDY: Buffer memory has no space for any packet when a PING token is received.

TRN-BRDY: Buffer memory has sent data when an IN token is received.

TRN-NRDY: Buffer memory has no send data when an IN token is received.

32B.9.8 Interrupt Transfer (Pipes 6 to 9)

This module performs an interrupt transfer in accordance with the period managed by the host controller. This module ignores (no response) PING packets in interrupt transfers. In addition, this module does not send a NYET handshake, but sends an ACK, NAK or STALL response.

Note that this module does not support high-bandwidth interrupt transfers.

32B.9.9 Isochronous Transfer (Pipes 1 and 2)

This module is provided with the following functions for isochronous transfers:

1. Notification of error information about isochronous transfers
2. Interval counter (IITV bit)
3. Data setup control for isochronous IN transfers (IDLY function)
4. Buffer flush function for isochronous IN transfers (IFIS bit)
5. SOF pulse output function

This module does not support high-bandwidth Isochronous transfers.

32B.9.9.1 Isochronous transfer error detection

This module has the following error information detection functions for the software to manage errors that occur during isochronous transfer.

Table 32B.31 and **Table 32B.32** describe the error checking procedure and interrupts that are generated.

1. PID error
The PID of the received packet is invalid.
2. CRC error and bit stuffing error
The received packet has a CRC error or invalid bit stuffing.
3. Max packet size over
The data size of the received packet is larger than the preset maximum packet size.
4. Overrun error and underrun error
 - (a) The buffer memory has no data when an IN token is received during IN-direction (send) transfer.
 - (b) The buffer memory has no space although an OUT token is received during OUT-direction (receive) transfer.
5. Interval error
An interval error occurs in the following cases:
 - (a) An IN token cannot be received within the interval frame during isochronous IN transfer.
 - (b) An OUT token cannot be received within the interval frame during isochronous OUT transfer.

Table 32B.31 Error Detection during Transmission/Reception of Token

Error Detection Priority	Error Type	Interrupt Generated at Error Detection and Status
1	PID error	No interrupt is generated (ignored as a corrupted packet).
2	CRC error, bit stuffing error	No interrupt is generated (ignored as a corrupted packet).
3	Overrun error, underrun error	An NRDY interrupt is generated and the OVRN bit is set. A zero-length packet is sent in response to an IN token. A data packet is not received in response to an OUT token.
4	Interval error	An NRDY interrupt is not generated.

Table 32B.32 Error Detection during Reception of Data Packet

Error Detection Priority	Error Type	Interrupt Generated at Error Detection and Status
1	PID error	No interrupt is generated (ignored as a corrupted packet).
2	CRC error, bit stuffing error	An NRDY interrupt is generated and the CRCE bit is set.
3	Packet size error (too large packet)	A BEMP interrupt is generated and the PID bit is set to STALL.

32B.9.9.2 DATA-PID

This module does not support high-bandwidth transfers.

The following shows actions that can be taken in response to a received PID.

1. IN direction:
 - (a) DATA0: Used to send packets.
 - (b) DATA1: Not used to send packets.
 - (c) DATA2: Not used to send packets.
 - (d) mData: Not used to send packets.

2. OUT direction (in full-speed operation):
 - (a) DATA0: Packets are received normally.
 - (b) DATA1: Packets are received normally.
 - (c) DATA2: Packets are ignored.
 - (d) mData: Packets are ignored.

3. OUT direction (in high-speed operation):
 - (a) DATA0: Packets are received normally.
 - (b) DATA1: Packets are received normally.
 - (c) DATA2: Packets are received normally.
 - (d) mData: Packets are received normally.

32B.9.9.3 Interval counter

(1) Outline of operation

The IITV bit in the PIPEPERI register can be used to set the interval of isochronous transfer. The interval counter enables the functions listed in **Table 32B.33**.

Table 32B.33 Functions of the Interval Counter

Transfer Direction	Function	Detecting Condition
IN	Transmit buffer flush function	An IN token cannot successfully be received within the interval frame during isochronous IN transfer.
OUT	Notification of unreceived token	An OUT token cannot successfully be received within the interval frame during isochronous OUT transfer.

Counting of intervals is based on received SOF packets or interpolated SOFs. Therefore, even if SOF packets are damaged, the isochronism can still be maintained. Frame intervals are set as $2n$ (micro) frames, where n is the value of the IITV bit.

(2) Interval counter initialization

This module initializes the interval counter under the following conditions:

- (a) Power on reset
The IITV bit is initialized.
- (b) Clearing of the buffer memory by the ACLRM bit
The IITV bit is not initialized but the counter is initialized.
- (c) USB bus reset

After the interval counter is initialized and a packet is successfully transferred, counting of intervals starts under the following conditions:

- 1) An SOF packet is received after data is sent in response to an IN token when PID = BUF.
- 2) An SOF packet is received after data is received in response to an OUT token when PID = BUF.

Note that the interval counter is not initialized in the following conditions:

- (a) The PID bit is set to NAK or STALL.
The interval timer is not stopped at this interval. The transaction will be attempted at the next interval.
- (b) USB bus reset or USB suspension
The IITV bit is not initialized. When an SOF packet is received, counting starts from the value existing before reception.

32B.9.9.4 Send data setup for isochronous transfer

This module becomes able to send data packets by isochronous transfer from the next frame after data is written to the buffer memory and then an SOF packet is detected. This is called “send data setup for isochronous transfer”.

This function can identify the frame with which data sending started.

If the buffer memory is in a double-buffer configuration and writing to both buffers has been completed, only the buffer to which writing finished earlier can transfer data. Therefore, even when several IN tokens are received within the same frame, only one packet of data is sent from the buffer memory.

When an IN token is received, if the buffer memory is ready for sending data, the data is transferred and a normal response is returned. However, if the buffer memory is not ready for sending data, a zero-length packet is sent and an underrun error occurs.

Figure 32B.11 shows examples of sending using the send data setup function for isochronous transfer by setting “IITV = 0” (each frame) in this module.

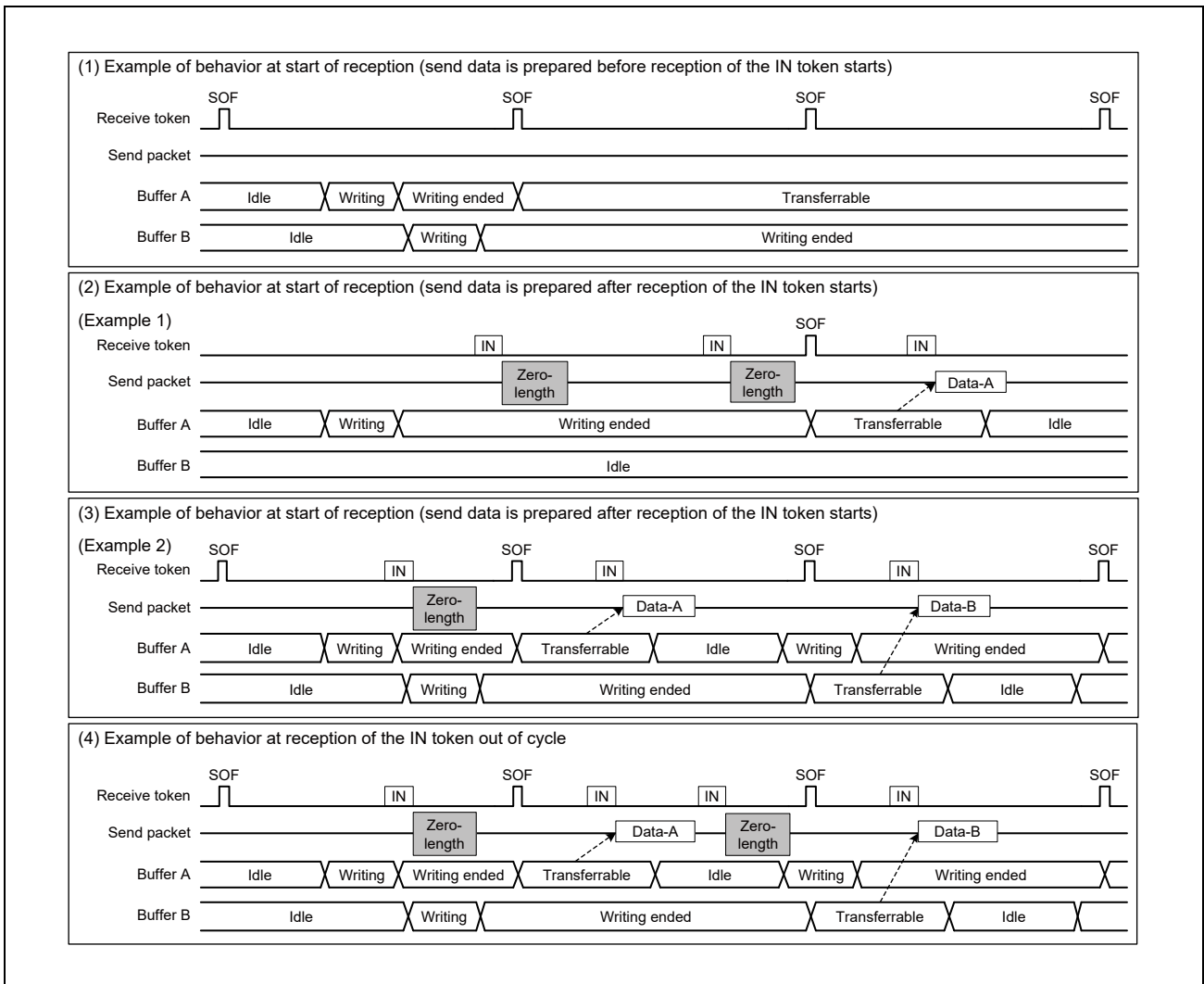

Figure 32B.11 Examples of Data Setup Function Behavior

32B.9.9.5 Transmit buffer flush for isochronous transfer

If this module does not receive an IN token in an interval frame and receives a (micro) SOF packet in the next frame during isochronous data transfer, this module handles the IN token as a corrupted token and clears the buffer that can send data to make the buffer writable.

At this time, if the buffer memory is in a double-buffer configuration and writing to both buffers has been completed, this module assumes the discarded buffer memory to be sent within the same interval frame. As a result, the buffer memory that is not discarded by reception of a (micro) SOF packet becomes to be able to transfer data.

The operation start timing of the buffer flush function varies with the value of the IITV bit.

1. If IITV is 0
Buffer flush operation is performed from the first frame after the pipe is enabled.
2. If IITV is not 0
Buffer flush operation is performed after the first successful transaction.

Figure 32B.12 shows an example of how the buffer flush function of this module behaves. For a token outside the set interval (token prior to the interval frame), however, this module sends the written data or a zero-length packet as an underrun error according to the data setup state.

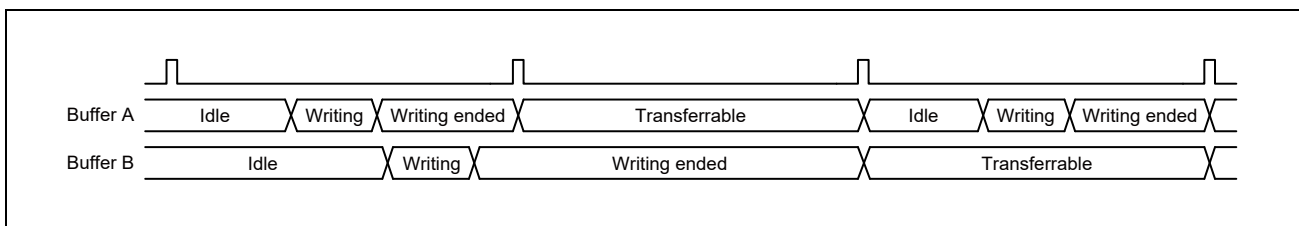

Figure 32B.12 Example of Buffer Flush Function Behavior

Figure 32B.13 shows an example of an interval error that occurs in this module.

There are five types of interval errors, as listed below. At timing (1) in the figure, an interval error occurs and the buffer flush function operates.

If an interval error occurs during IN transfer, the buffer flush function starts. If an interval error occurs during OUT transfer, an NRDY interrupt occurs.

Use the OVRN bit to determine whether an error is an NRDY interrupt (such as a receive packet error) or an overrun error.

In the figure, responses to tokens indicated as shaded boxes are made in accordance with the buffer memory state.

1. IN direction:
 - (a) If the buffer is ready to transfer data, data is transferred and a normal response is returned.
 - (b) If the buffer is not ready to transfer data, a zero-length packet is sent and an underrun error occurs.
2. OUT direction:
 - (a) If the buffer is ready to receive data, data is received and a normal response is returned.
 - (b) If the buffer is not ready to receive data, data is discarded and an overrun error occurs.

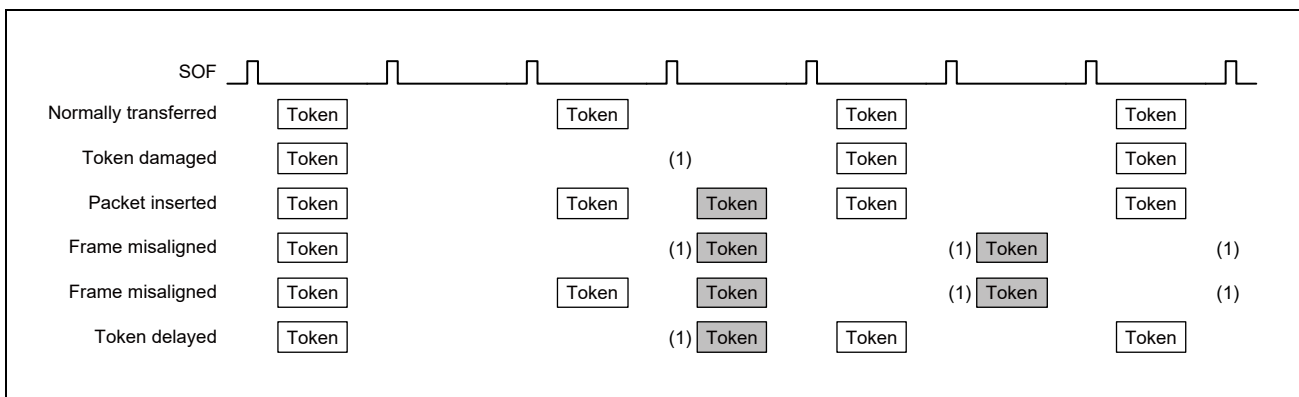

Figure 32B.13 Example of Occurrence of Interval Error (when IITV is 1)

32B.9.10 SOF Interpolation Function

If the controller cannot receive data at intervals of 1 ms (in full-speed operation) or 125 μ s (in high-speed operation) due to corruption or missing of an SOF packet, the controller internally interpolates the SOF. The controller starts SOF interpolation upon receiving an SOF packet when both the USBE bit and SUSPM bit are set to 1.

The interpolation function is initialized under the following conditions:

- (1) Power on reset
- (2) USB bus reset
- (3) Suspended state detected

The SOF interpolation operates according to the following specifications:

- (1) Frame interval (125 μ s or 1 ms) is based on the results of the reset handshake protocol.
- (2) The interpolation function does not operate until an SOF packet is received.
- (3) After receiving the first SOF packet, this module interpolates the SOF by using the 60-MHz internal clock to measure 125 μ s or 1 ms.
- (4) After receiving the second or a subsequent SOF packet, this module interpolates the SOF by using the previous reception interval.
- (5) Interpolation is not performed in the suspended state or while a USB bus reset is being received.
(If this module enters the suspended state in high-speed operation, interpolation continues for 3 ms after receiving the last packet.)

The SOF interpolation function operates with the following functions:

- (1) Updating of frame number or micro-frame number
- (2) SOFR interrupt and micro SOF lock
- (3) SOF pulse output
- (4) Counting of isochronous transfer intervals

If an SOF packet is lost in full-speed operation, the FRNM bit in the FRMNUM register is not updated.

If a micro SOF packet is lost in high-speed operation, the UFRNM bit in the uFRMNUM register is updated.

However, if a micro SOF packet for which “micro-FRNM = 000” is set is lost, the FRNM bit is not updated. In this case, the FRNM bit is not updated even if subsequent micro SOF packets for which “micro-FRNM = 000” is not set are successfully received.

32B.9.11 Link Power Management Processing

According to the Link Power Management specification, the existing suspend state is redefined as the L2 state and a new L1 state is defined as a state where transition and resumption at a lower latency than L2 (suspend) are possible.

The table below compares the features of the L2 (suspend) state and L1 state.

Table 32B.34 Comparison Between Suspend (L2) State and L1 State

Item	L1	Suspend (L2)
Transition	LPM Transaction	3-ms idle period
Host-activated resumption	(Host)	(Host)
	Minimum drive period specifiable by the host. Specified between 75 μ s to 1.175 ms	Min. 20-ms K drive
	(Device)	(Device)
	10- μ s K drive	10-ms K drive
Device-activated resumption	(Device)	(Device)
	50- μ s K drive	1-ms to 15-ms K drive
	(Host)	(Host)
	60- to 990- μ s K drive	Min. 20-ms K drive
	(Device)	(Device)
	10- μ s K drive	10-ms K drive
Signaling	Low and Full Speed Idle	Low and Full Speed Idle

The following describes the processing for transition to and resumption from the L1 state.

32B.9.11.1 Descriptor

This module must return its own descriptor when receiving the GetDescriptor command.

Whether the contents of the descriptor to be returned need to be modified is dependent on whether this module responds to the transition to and resumption from the L1 state with an LPM transaction. The details are summarized in the table below.

Table 32B.35 Relationship between LPM Response and Descriptor

LPM Response	bcdUSB	Presence of USB 2.0 Ex.Desc	USB 2.0 Ex.Desc LPM	Response When LPM Is Received	Remarks
Not respond	0200	Not present	—	Not Respond	Standard action in the case where this module does not respond to LPM
	0201	Present	LPM = 0	STALL	This is when rejection of response to LPM is explicitly declared. In this case, it is necessary to send a STALL response instead of making no response.
Respond	0201	Present	LPM = 1	ACK or NYET	Standard action in the case where this module responds to LPM

Whether to respond to transition to and resumption from L1 is declared by the LPM bit of the USB 2.0 extension descriptor. To provide this module with the USB 2.0 extension descriptor, it is necessary to set the bcdUSB field of the device descriptor to 0201 or greater.

When not responding to LPM, set the bcdUSB value to 0200 without providing this module with the USB 2.0 extension descriptor. In this case, it is necessary to ignore any LPM token received.

When not responding to LPM, it is also possible to set bcdUSB to 0201 and set the LPM bit of the USB 2.0 extension descriptor to 0 (noncompliant). In this case, however, it is not allowed to ignore LPM and is necessary to send a STALL response.

When responding to LPM, set bcdUSB to 0201 and the LPM bit of the USB 2.0 extension descriptor to 1 (compliant). This grants this module to send an NYET or ACK in response to an LPM token.

32B.9.11.2 Basic processing

This module needs to execute the following processing.

1. Responds to the LPM token received from the host with “No response”, “ACK”, “NYET”, or “STALL” according to this module's own state.
2. Transitions to the L1 state if it fails to detect the retransmission of an LPM token for 8 μ s after making an ACK response.
3. Detects a K drive of the host and performs resume processing to the idle state.
4. Performs resume processing to the idle state based on the Remote Wake signal.

For 1, the software specifies the response method according to the values of the L1RESPEN, L1RESPMD, and L1NEGOMD bits in the PL1CTRL register. The hardware makes the response that is designated by the software upon receiving an LPM token.

For 2, both retransmission control and transition to the L1 state are processed by the hardware. Transition to the L1 state can be identified through a DVST interrupt.

For 3, a RESM interrupt occurs on detection of host K in the L1 state.

For 4, starting the Remote Wake processing can be instructed to the hardware by setting the WKUP bit by the software. The specification stipulates that the software clears this bit on resumption from the L2 state. On the other hand, the hardware clears this bit on resumption from the L1 state.

32B.9.11.3 HIRD value negotiation

The HIRD value contained in the LPM token is the K period of the host on resumption from the L1 state.

This module can respond with ACK if the received HIRD value falls within the desired range as specified by the L1NEGOMD and HIRDTHR bits in the L1CTRL register; otherwise, this module can respond with NYET and request the host to modify the HIRD value.

NOTE

This HIRD value negotiation function must also be supported on the host side.

32B.9.12 DMA Mode

32B.9.12.1 Register mode/link mode

The DMS bit in the CHCFG_n register can be used to switch between register mode and link mode.

Table 32B.36 DMA mode settings

DMS (CHCFG)	Mode	Description
0	Register mode	Performs DMA transfer based on the values set by Next Register Set.
1	Link mode	Accesses the descriptor area, and executes DMA transfer based on the values set by descriptors. This module repeats descriptor reading and DMA transfer unless the descriptor settings are changed or the control register is used to stop the processing.

(1) Register mode

In register mode, this module executes DMA transfer based on the values set in internal registers.

Two sets of the transfer-source address, transfer-destination address, and number of bytes to be transferred can be held (in Next0 Register Set and Next1 Register Set registers). One of these Next registers can be used to execute transfer, and both Next registers can be used to execute continuous transfer.

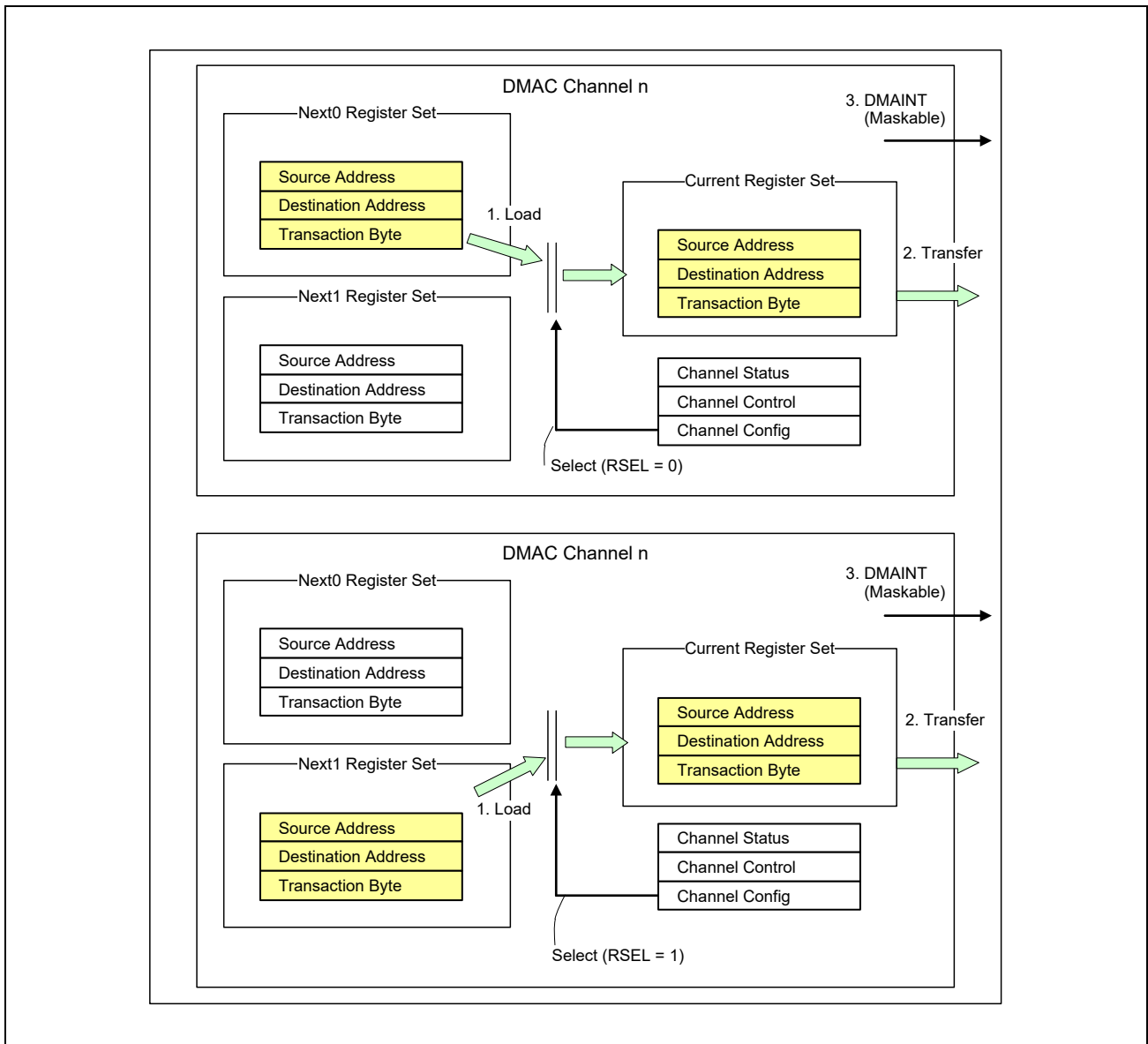

Figure 32B.14 Overview of Normal Behavior of Register Mode

The upper part of the above figure indicates a case when Next0 Register Set is processed. The lower part of the above figure indicates a case when Next1 Register Set is processed.

(a) Operation flow of register mode

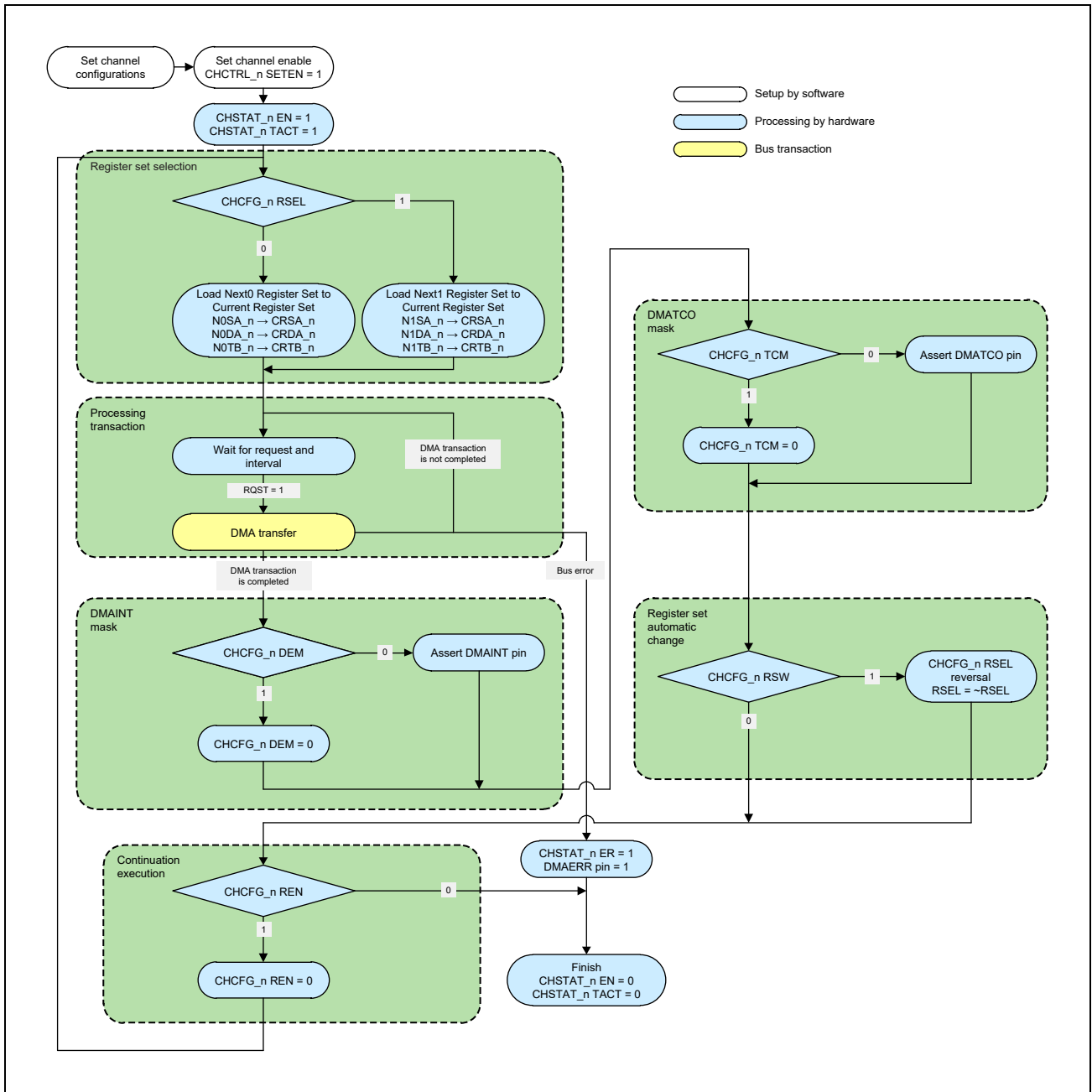

Figure 32B.15 Register Mode Operation Flow

Description of the register mode operation flow:

1. Channel setting

The Next0 Register Set or Next1 Register Set register is set (transfer-destination address, transfer-source address, and total number of bytes to be transferred). In addition, the FIFO channel, volume of transfer data, and other items are set for USB control that is used for the Channel Register Set register.

No software settings are required in OUT transfer (reception in peripheral mode) or in IN transfer (transmission in peripheral mode) because the hardware sets the transfer source or destination address according to the setting of the CURPIPE bits in the DxFIFOSEL register.

(see **Section 32B.9.13, DMA Transfer**).

2. Register set selection

When 1 is written to the SETEN bit in the CHCTRL_n register, the EN and TACT bits in the CHSTAT_n register are set to 1. As a result, the values set by the Next Register Set register selected by the RSEL bit in the CHCFG_n register are loaded to the Current Register Set register.

3. DMA transaction

A DMA transaction is executed based on the values that are set. For details about transfer, **Section 32B.9.13, DMA Transfer**.

4. The USBFDMAmn masking

The USBFDMAmn interrupt is masked depending on the value of the DEM bit in the CHCFG_n register. If DEM = 1, the USBFDMAmn interrupt is masked, and the DEM bit is automatically cleared to 0.

5. DMATC masking

DMATC from DMAC control to USB control is masked depending on the value of the TCM bit in the CHCFG_n register. If TCM = 1, DMATC is masked, and the TCM bit is automatically cleared to 0.

6. Automatic register set switchover

Whether the current Next register set is to be switched to the other Next register set is determined by the value of the RSW bit in the CHCFG_n register.

7. Continuation of execution

Whether to continue DMA transfer is determined by the value of the REN bit in the CHCFG_n register. If REN = 0, the EN and TACT bits in the CHSTAT_n register are cleared to 0, and DMAC operation stops. If REN = 1, DMAC operation continues, and the REN bit is automatically cleared to 0.

(b) Register mode setting

- Register mode setting

The register set to be processed is selected.

Table 32B.37 Register Mode Setting

DMS (CHCFG_n)	RSEL (CHCFG_n)	Description
0	0	Processes Next0 Register Set.
	1	Processes Next1 Register Set.

- USBFDMAmn masking

The USBFDMAmn interrupt can be masked.

Table 32B.38 USBFDMAmn Mask Setting

DEM (CHCFG_n)	Description
0	Asserts the USBFDMAmn interrupt when the DMA transaction is completed.
1	Does not assert the USBFDMAmn interrupt even when the DMA transaction is completed. After the DMA transaction is completed, the DEM bit is cleared to 0.

- DMATC mask setting

DMATC from DMAC control to USB control can be masked.

Table 32B.39 DMATC Mask Setting

DEM (CHCFG_n)	Description
0	Asserts DMATC when the DMA transaction is completed.
1	Does not assert DMATC even when the DMA transaction is completed. After the DMA transaction is completed, the TCM bit is cleared to 0.

- Automatic transaction execution for a register set

After a DMA transaction finishes, another DMA transaction can be executed.

Table 32B.40 Automatic Execution Setting for a Register Set

REN (CHCFG_n)	Behavior	Remarks
0	The EN bit is cleared and DMA operation is terminated when the DMA transaction for the register set that is set by RSEL finishes.	Use this setting to execute a DMA transaction only once.
1	After a DMA transaction finishes, DMA transfer of the contents of the next register set continues. The REN bit is cleared to 0 when continuous transfer is successful.	Use this setting to continue processing of register set contents.

- Automatic register set switchover setting

After a DMA transaction finishes, the next register set to be processed can be switched.

Table 32B.41 Automatic Execution Setting for a Register Set

RSW (CHCFG_n)	Behavior	Remarks
0	The register set is not switched when a DMA transaction finishes.	Use this setting to use only one register set.
1	When REN = 1 and a DMA transaction finishes, the RSEL setting is automatically reversed to select the other register set.	Use this setting to switch the register set.

(c) Example of setting the register mode

- Example of setting the register mode when using only the Next0 register set

Table 32B.42 Register Mode Setting Example

DMS (CHCFG_n)	RSEL (CHCFG_n)	DEM (CHCFG_n)	TCM (CHCFG_n)	RSW (CHCFG_n)	REN (CHCFG_n)
0	0	0	0	0	0
(register mode)	(Next0)	(not masked)	(not masked)	(not switched)	(continuous execution disabled)

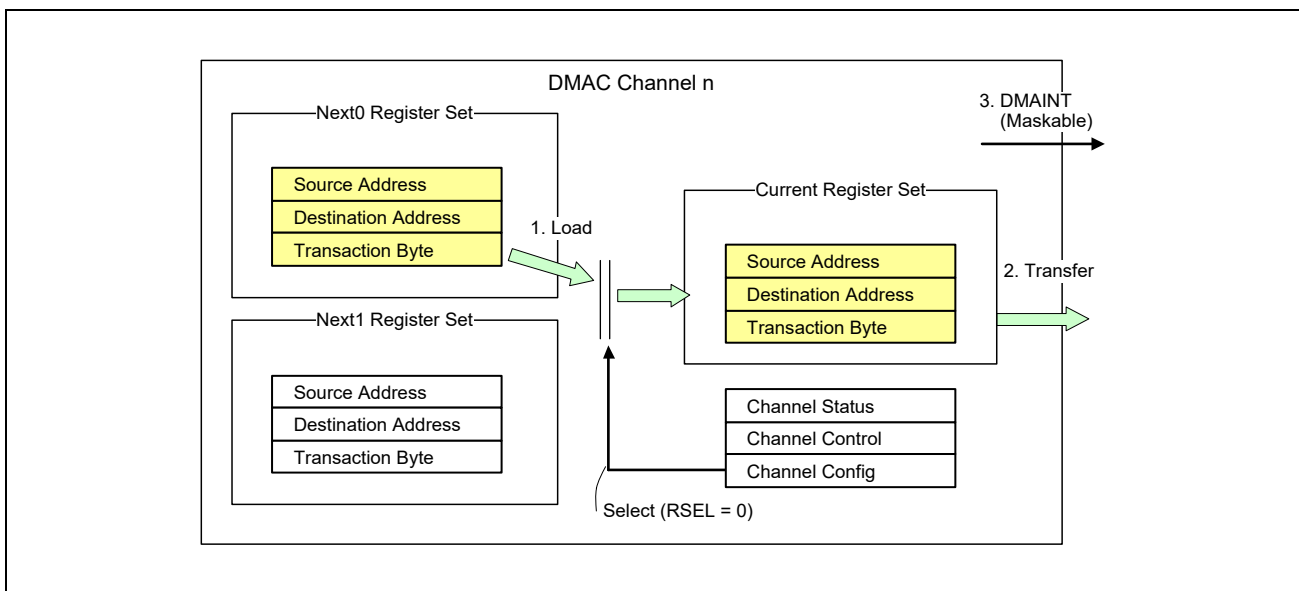

Figure 32B.16 Register Mode Setting Example 1

1. By writing 1 to the SETEN bit in the CHCTRL_n register, the EN bit in the CHSTAT_n register is set to 1. As a result, the contents of Next0 Register Set are loaded to Current Register Set.
2. A DMA transaction is executed based on the values of Current Register Set and Channel Register Set.
3. Because the DEM bit in the CHCFG_n register is 0, the USBFDMAmn interrupt is asserted after the DMA transaction finishes.
4. Because the TCM bit in the CHCFG_n register is 0, DMATC is asserted after the DMA transaction finishes.
5. Because the REN bit in the CHCFG_n register is 0, the EN bit in the CHSTAT_n register is cleared to 0, and the operation ends.

- Example of setting the register mode when using two register sets continuously

Table 32B.43 Automatic Register Set processing Setting

DMS (CHCFG_n)	RSEL (CHCFG_n)	DEM (CHCFG_n)	TCM (CHCFG_n)	RSW (CHCFG_n)	REN (CHCFG_n)
0	0	1	0	1	1
(register mode)	(Next0)	(masked)	(not masked)	(switched)	(continuous execution enabled)

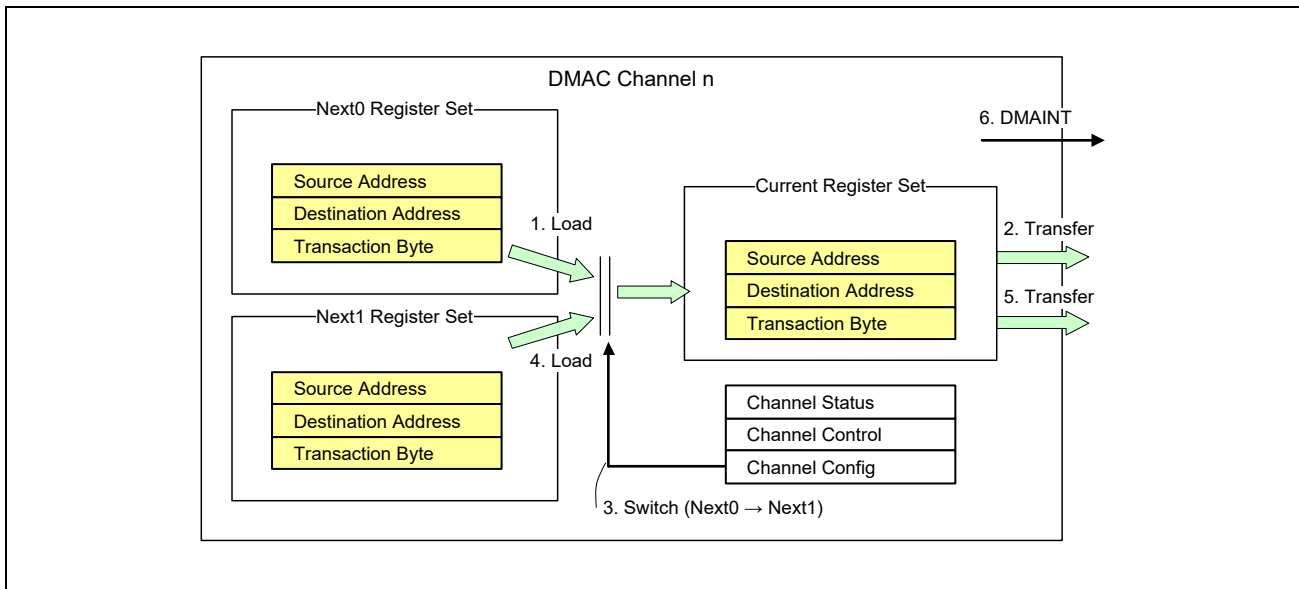

Figure 32B.17 Register Mode Setting Example 2

1. By writing 1 to the SETEN bit in the CHCTRL_n register, the EN bit in the CHSTAT_n register is set to 1. As a result, the contents of Next0 Register Set are loaded to Current Register Set.
2. A DMA transaction is executed based on the values of Current Register Set and Channel Register Set.
3. Because the DEM bit in the CHCFG_n register is 1, the USBFDMAn interrupt is not asserted after the DMA transaction finishes.
4. Because the REN bit in the CHCFG_n register is 1, operation continues. The REN bit is automatically cleared to 0.
5. Because the RSW bit in the CHCFG_n register is 1, the next register set to be processed is switched (RSEL = 0 to 1).
6. The contents of Next1 Register Set are loaded to Current Register Set.
7. A DMA transaction is executed based on the values of Current Register Set and Channel Register Set.
8. Because the DEM bit in the CHCFG_n register is 0, the USBFDMAn interrupt is asserted after the DMA transaction finishes.
9. Because the TCM bit in the CHCFG_n register is 0, DMATC is asserted after the DMA transaction finishes.
10. Because the REN bit in the CHCFG_n register is 0, the EN bit in the CHSTAT_n register is cleared to 0, and the operation ends.

(2) Link mode

In link mode, this module reads the value set in a descriptor placed in an external storage area to execute a DMA transaction. In DMAC, there are Next Link Address (NXLA_n) and Current Link Address (CRLA_n) registers for each channel. The Next Link Address (NXLA_n) register is used to set the address of the descriptor to be read the next time. The Current Link Address (CRLA_n) register is used to display the descriptor address for the current DMA transaction.

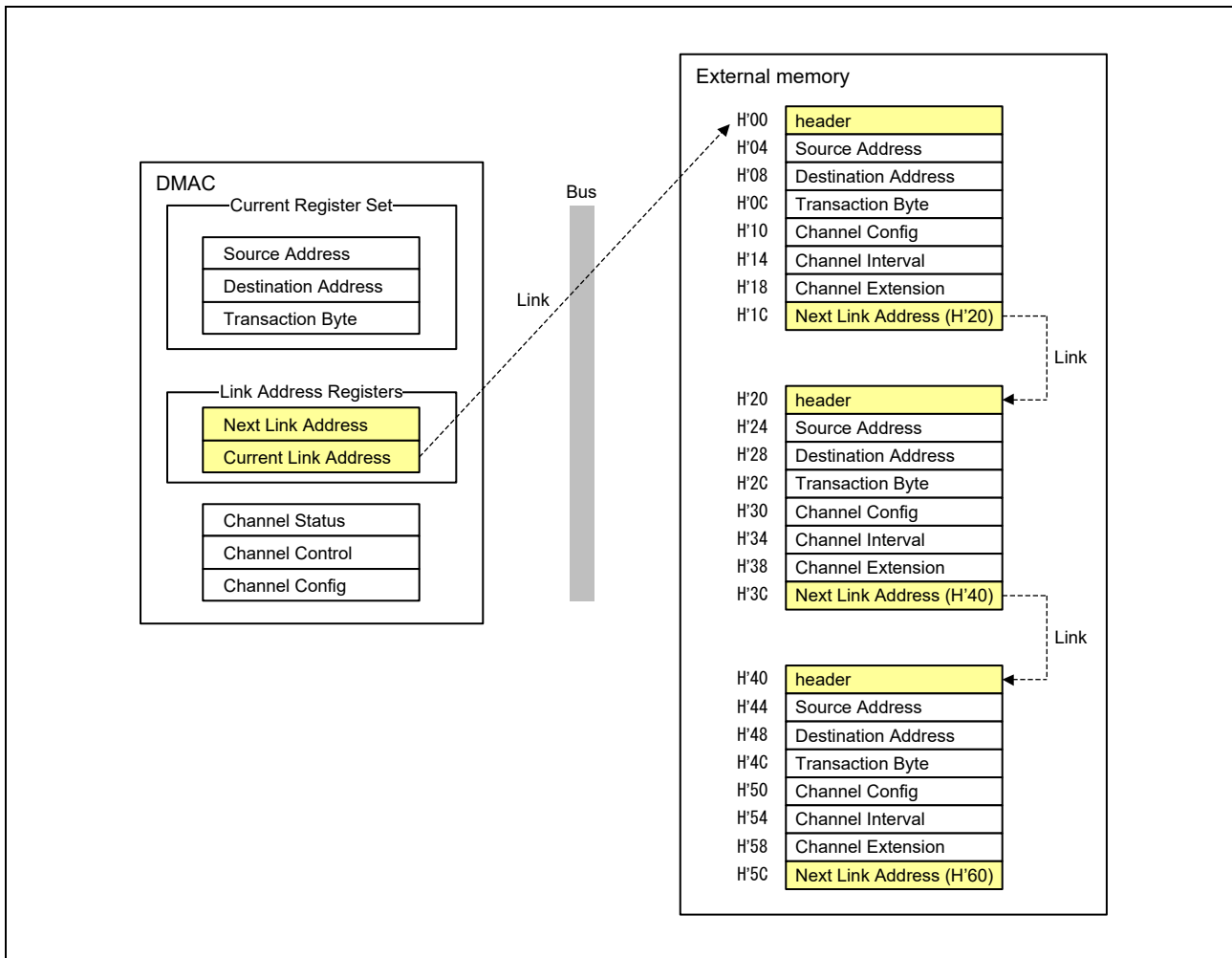

Figure 32B.18 Overview of Link Mode

(a) Operation flow of link mode

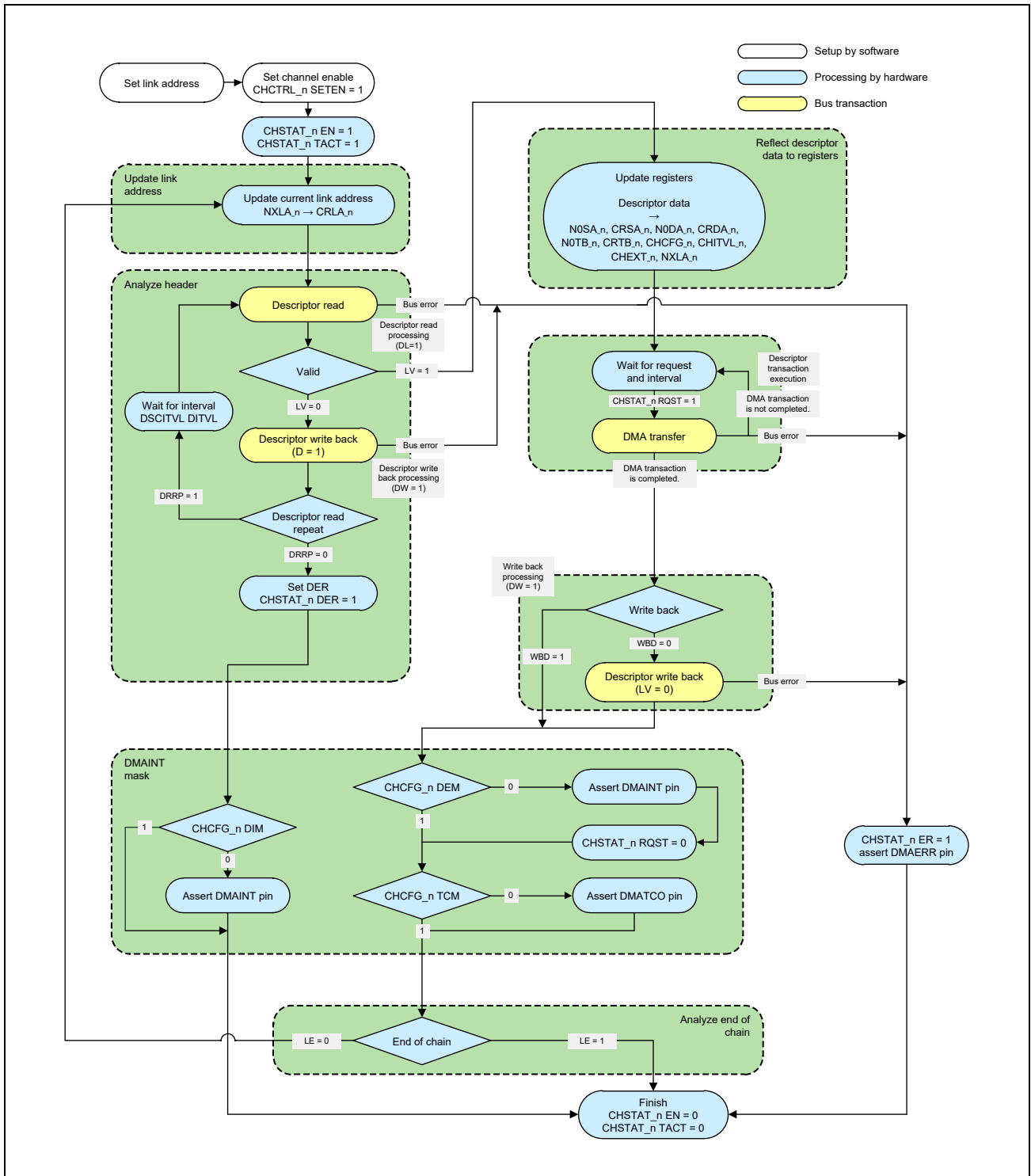

Figure 32B.19 Link Mode Operation Flow

Description of the link mode operation flow:

1. Channel setting
The beginning address of the link destination is set in the NXLA_n register.
2. Link address updating
If 1 is written to the SETEN bit in the CHCTRL_n register, the EN and TACT bits of the CHSTAT_n register are set to 1. As a result, the address set in the NXLA_n register is loaded to the CRLA_n register.
3. Descriptor reading and header judgment
A read of the descriptor starts, and DMAC checks the contents of header. If LV = 0, this module writes 1 back to the D bit of header. After that, if the DRRP bit in the CHCFG_n register is 1, this module waits for the time intervals set by the DSCITVL register, and then reads the same descriptor again. If DRRP = 0, the DER bit in the CHSTAT_n register is set to 1, and this module is placed in the end state (both EN and TACT bits in the CHSTAT_n register are 0). At this time, if the DIM bit in the CHCFG_n register is 0, this module asserts the USBFDMAmn interrupt.
4. Descriptor setting
If LV = 1, the data read from the descriptor is loaded to Current Register Set and Channel Register Set. In addition, the next link target is loaded to the NXLA_n register.
5. DMA transaction
A DMA transaction is executed based on the values that are set. For details about transfer, see **Section 32B.9.13, DMA Transfer**.
6. Header write-back
If WBD of header is 0, DMAC writes LV = 0 to the header area.
7. USBFDMAmn masking
If the DEM bit in the CHCFG_n register is 0, this module asserts the USBFDMAmn interrupt.
8. DMATC masking
If the TCM bit in the CHCFG_n register is 0, this module asserts DMATC.
9. Link end judgment
If LE of header is 1, the EN and TACT bits in the CHSTAT_n register are cleared to 0, and DMAC terminates operation. If LE is 0, this module updates Current Register Set, and then restarts reading the next descriptor.

(b) Register setting

- Link mode setting

To use link mode, set the DMS bit in the CHCFG_n register to 1.

Table 32B.44 Link Mode Setting

DMS (CHCFG_n)	Description
1	This module operates in link mode. The setting of this bit cannot be changed by using a descriptor.

- Link address setting

The Next Link Address (NXLA_n) and Current Link Address (CRLA_n) registers are used to indicate a link target. Before starting link mode, set the link target in the NXLA_n register.

After reading a descriptor, this module updates the NXLA_n register to the next link. Note that the CRLA_n register indicates the address of the link target that is being executed.

Table 32B.45 Link Address Register Set

Register	Description
Next Link Address Register (NXLA_n)	This register is used to set and display the next link target. Before starting link mode, set the address of the link target in this register.
Current Link Address Register (CRLA_n)	This register is used to display the link target that is being executed. This is a read-only register.

(c) Descriptor setting

DMAC supports multiple descriptor formats.

A switchover between formats is specified by using the DSCFM field of bits [31:28] of the 1st word (header) of the descriptor.

The following table shows the relationship between DSCFM values and descriptor formats.

Table 32B.46 Descriptor Formats

DSCFM	Descriptor Size	Next Link Address	Channel Extension	Channel Interval	Channel Config	Transaction Size	Destination Address	Source Address	header
3	4 words	✓	— (reload)	— (reload)	— (reload)	— (header)	✓	✓	✓ (with STS)
1	8 words	✓	✓	✓	✓	✓	✓	✓	✓ (no STS)
Other than the above	If DSCFM is set to a value that is not 1 or 3, operation cannot be guaranteed. Make sure that DSCFM is set to 1 or 3.								

Table 32B.47 Explanation of the Marks in **Table 32B.46**

Field	Mark	Description	Remarks
Header	✓ (with STS)	The STS field of bits [15:0] in the header is valid. The value set in the STS field is used as the total number of transfer bytes (Transaction Size).	—
	✓ (no STS)	The STS field of bits [15:0] in the header is invalid. The value of "Transaction Size" in the descriptor is used as the total number of bytes.	—
Source Address	✓	Specify the source address.	—
Destination Address	✓	Specify the destination address.	—
Transaction Size	✓	Specify the transaction size.	—
	— (header)	Omit the transaction size. The value set in the STS field is used as the total number of transfer bytes (Transaction Size)	Because the STS field is of 16 bits, a maximum of 65,535 bytes can be set.
Channel Config Channel Interval	✓	Specify Channel Config, Channel Interval, and Channel Extension.	—
Channel Extension	— (reload)	Omit Channel Config, Channel Interval, and Channel Extension. The previous settings (the values of the CHCFG_n, CHITVL_n, and CHEXT_n registers of the last time) are inherited.	—
Next Link Address	✓	Specify the next descriptor address (Next Link Address) to be read after DMA transfer of the descriptor.	—

DMAC sequentially interprets data read from descriptors. If the number of words specified for DSCFM is less than 8, place the data of descriptors that are indicated by “✓” in **Table 32B.46** on memory.

No software settings are required in OUT transfer (reception in peripheral mode) or in IN transfer (transmission in peripheral mode) because the hardware sets the transfer source or destination address according to the setting of the CURPIPE bits in the DxFIFOSEL register.

Table 32B.48 Example of Placing Descriptors

DSCFM	Address							
	Link Address + H'1C	Link Address + H'18	Link Address + H'14	Link Address + H'10	Link Address + H'0C	Link Address + H'08	Link Address + H'04	Link Address + H'00
H'3	—	—	—	—	Next Link Address	Destination Address	Source Address	header
H'1	Next Link Address	Extension	Interval	Config	Transaction Byte	Destination Address	Source Address	header

- header

The header area provides the descriptor status and other information as shown below.

DMAC reads this area before DMA transfer in link mode starts. After a DMA transaction terminates, DMAC writes the transfer status back to this area.

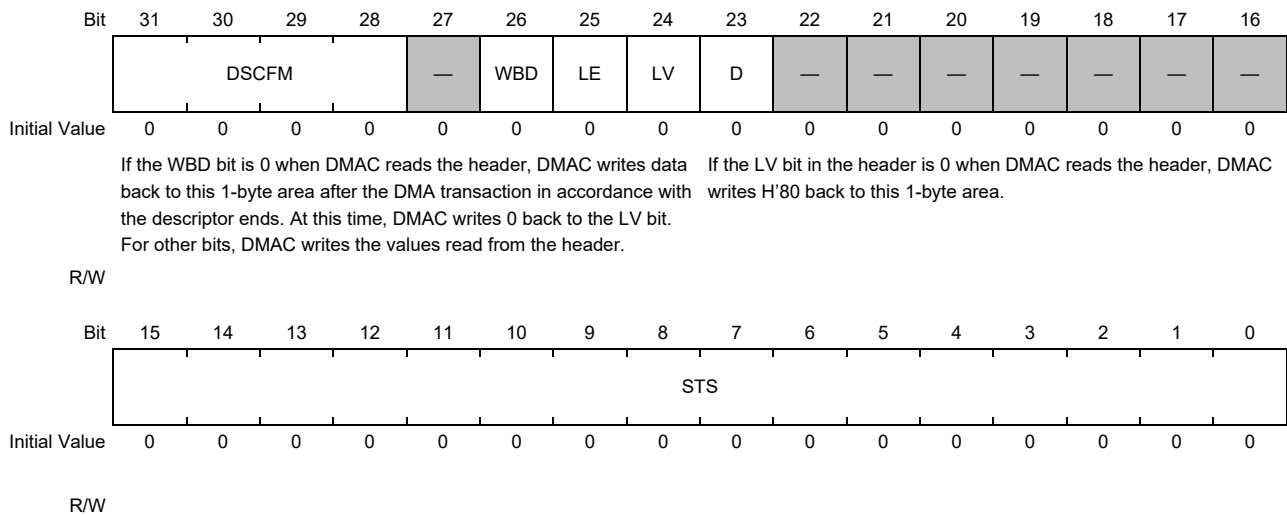

Figure 32B.20 Header Area

Table 32B.49 Header Area (1/2)

Bit	Bit Name	Initial Value	R/W	Description
31 to 28	DSCFM			Descriptor Format Specifies the descriptor format (length and combination of descriptors). For details see Table 32B.46 .
27	—			Reserved area. Set 0.
26	WBD			Write Back Disable Masks a write-back operation for the LV bit. If this bit is 1, DMAC does not perform a write-back operation. 0: Writes 0 back to the LV bit. 1: Does not perform a write-back operation for the LV bit.
25	LE			Link End Indicates that the link will end with the DMA transaction for this descriptor. Set this bit to 1 to indicate the end of link. 0: The link continues. 1: The link ends.

Table 32B.49 Header Area (2/2)

Bit	Bit Name	Initial Value	R/W	Description
24	LV			Link Valid Indicates that this descriptor is valid. If WBD = 0, after DMAC executes the DMA transaction written in the descriptor, DMAC writes 0 to this bit. When header is set, set 1 to this bit. 0: This descriptor is invalid. 1: This descriptor is enable.
23	D			Descriptor Error Indicates a descriptor access error. If LV is 0 when the descriptor is read, DMAC writes 1 back to this bit. 0: A descriptor error has not occurred. 1: LV was 0 when the descriptor was read.
22 to 16	—			Reserved area. Set 0.
15 to 0	STS			Short Transaction Size If DSCFM is 3, the transaction size is set (in bytes). The maximum number of transfer bytes that can be set is 65,535. If DSCFM is 3, Do not set 0 for STS. If 0 is set, operation cannot be guaranteed.

If descriptors are added sequentially while DMAC is operating, the access that the CPU sets 0 to the LV bit and the access that DMAC writes 1 back to the D bit might contend with each other. If this contention occurs, prior-written data is overwritten by latter-written data.

To prevent this problem from occurring, DMAC performs a write-back operation for the D bit in a byte-write manner. Therefore, the CPU must also set LV to 1 in a byte-write manner. Because the byte lanes for the D and LV bits are different, by writing data to different areas, occurrence of this problem can be prevented.

- Settings of descriptors other than header

The specifications of data of the descriptors other than header are the same as the specifications of internal registers.

- Settings specified when descriptors are accessed

The MHPROT pin output can be set for the LWPR and LDPR fields of the DCTRL register when descriptors are accessed. Set it according to the access target in which descriptors are deployed.

- Descriptor areas and DMA transfer areas

The following provides an overview of the descriptor areas and DMA transfer areas that are accessed by DMAC.

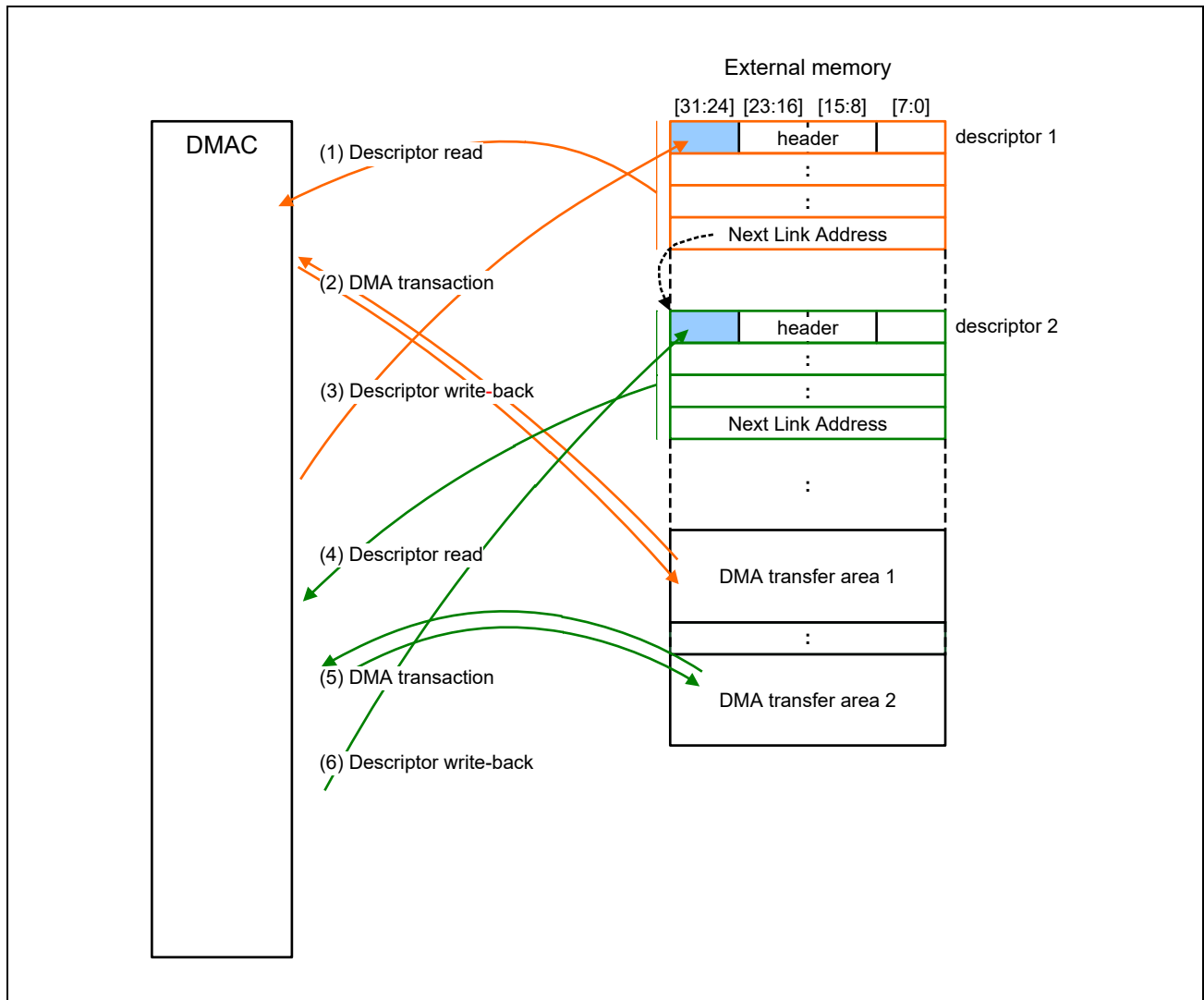

Figure 32B.21 Overview of Descriptor Areas and DMA Transfer Areas

- (1) Descriptor read
DMAC loads a value from the internal NXLA_n register to the CRLA_n register, and then reads a descriptor from the external memory space indicated by the CRLA_n register (descriptor 1).
- (2) DMA transfer
If the LV bit of the header descriptor is 1, DMAC performs a DMA transfer in accordance with the descriptor information.
- (3) Descriptor write-back
After performing a DMA transfer of data by the number of bytes that are set, if the WBD bit in header is 0, DMAC performs write-back for bits [31:24] in header of Descriptor 1. For the LV field, 0 is written back. For other fields, the values read in (1) are written back on a byte-size basis.
- (4) Descriptor read
If the value of the LE bit in the header descriptor that was read previously (in (1)) is 0, DMAC reads the next descriptor from the address (descriptor2) indicated by Next Link Address in the current descriptor.

(5) DMA transfer

If the LV bit in the header descriptor is 1, DMAC performs a DMA transfer in accordance with the descriptor information.

(6) Descriptor write-back

After performing a DMA transfer of data by the number of bytes that are set, if the WBD bit in header is 0, DMAC performs write-back for bits [31:24] in header of Descriptor 2. For the LV field, 0 is written back. For other fields, the values read in (4) are written back on a byte-size basis.

(Steps (4) to (6) are repeated.)

If LE = 1 and WBD = 0 in header, DMAC performs a DMA transfer with the descriptor settings, writes 0 back to the LV bit in header, and then terminates processing.

If LE = 1 and WBD = 1 in header, DMAC performs a DMA transfer with the descriptor settings, and then terminates processing (without performing write-back).

If LV = 0 in header, DMAC writes 1 back to the D bit in header, and then, if the DRRP bit in the CHCFG_n register is 1, DMAC waits for the number of intervals specified by the DITVL field of the DSCITVL_n register, and then reads the descriptor again. If DRRP = 0, DMAC terminates processing.

- Notes on descriptors

- In link mode, settings can be changed by reading descriptors. However, it is impossible to synchronize the setting change times and hardware requests. Therefore, to use hardware requests, before setting the SETEN bit in the CHCTRL_n register, set the AM, LVL, HIEN, LOEN, and SEL bits in the CHCFG_n register. Note that these setting bits must not be changed in descriptors.
- Descriptors cannot be used to change the DMS field in the CHCFG_n register (DMAC is always placed in link mode). Although descriptors can be used to change the settings of the REN, RSW, and RSEL fields in the CHCFG_n register, changes of those fields do not affect operation.
- The descriptor can be initialized by overwriting the memory area corresponding to the descriptor you intend to initialize while the DMAC is not operating. The DMAC determines whether or not the descriptor is valid by referring to the DSCFM field and LV bit in the header. Accordingly, set the areas in memory corresponding to the DSCFM field and LV bit to 1 or 3, and to 1, respectively, before enabling DMAC operation.
- To set the next descriptor on memory while DMAC is operating, make sure that 1 is written to the LV bit after the descriptors subsequent to header (Source Address, Destination Address, ..., Next Link Address) are set. If this is not performed and descriptor setting by the CPU and descriptor reading by DMAC contend, DMAC performs a DMA transfer using the previous values of those descriptors (Source Address, Destination Address, ..., Next Link Address).
- To leave the write-back information for the D bit of header, make sure that 1 is written to the LV bit of header in a byte-access manner.

(d) Link configuration example

In link mode, descriptors can be configured as shown below.

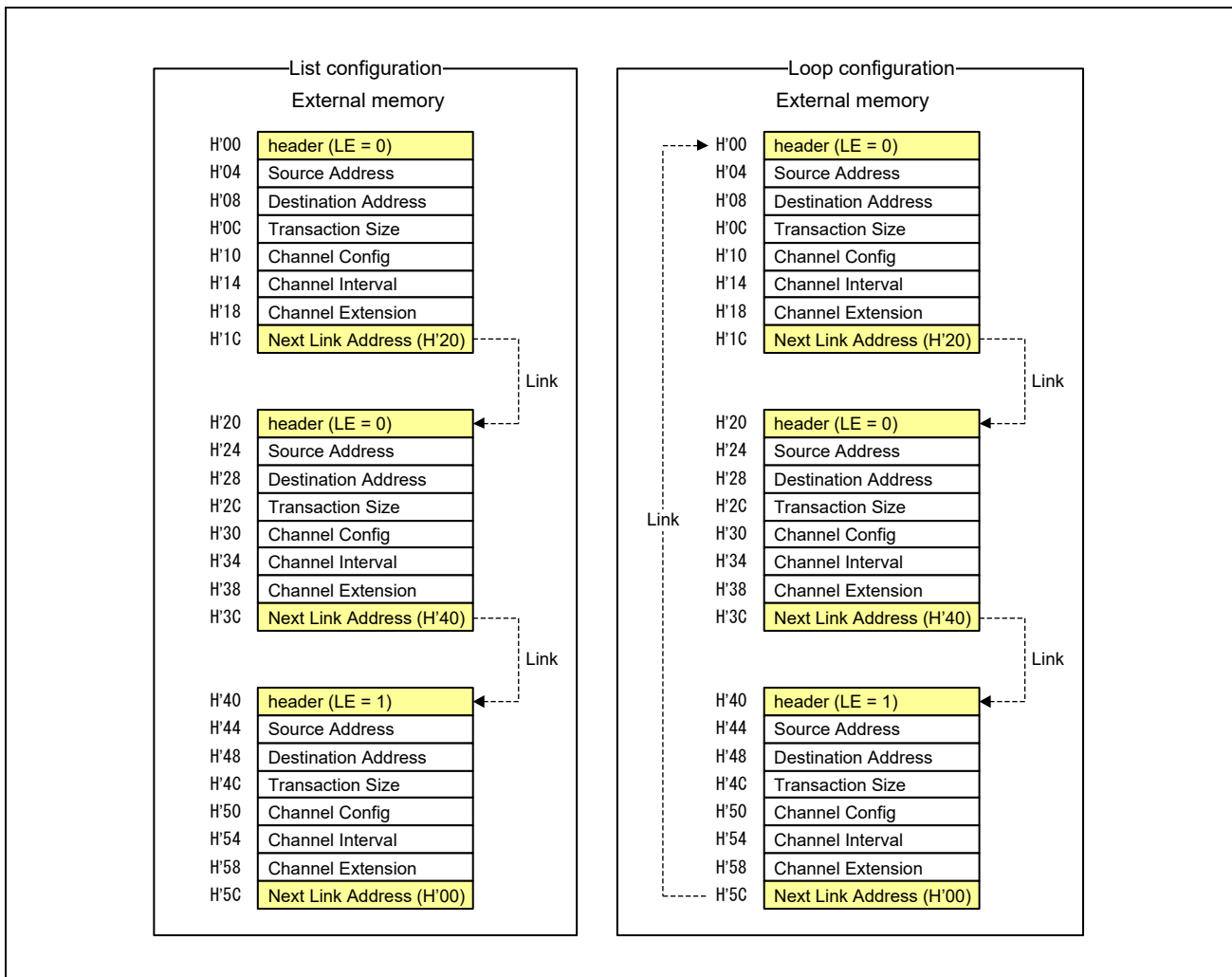

Figure 32B.22 Link Mode Configuration Example

- List configuration

The link ends by setting 1 for the LE bit in the header of the last descriptor.

- Loop configuration

A loop of descriptors can be created by setting the link target of the last descriptor to the address of the first descriptor. To end the loop, change the value of the LE bit of header to 1 or use the transfer interrupt procedure.

32B.9.12.2 Write only mode

Write-only mode is enabled by setting 1 for the WONLY bit in the CHCFG_n register.

Table 32B.50 Write-Only Mode Setting

WONLY (CHCFG)	Mode	Description
0	Normal mode	A DMA transfer is performed using the values set in Next Register Set.
1	Write-only mode	A DMA write transfer is performed without performing a DMA read transfer.

In write-only mode, no DMA read transfer is performed (note that descriptors are read in the same way as in normal mode). In register mode, the values set in the NxSA_n register (if RSEL = 0, x = 0; if RSEL = 1, x = 1) are used as write data. In link mode, the values of the SA fields of descriptors are used as write data.

Use this mode to, for example, initialize the memory area.

32B.9.13 DMA Transfer

This chapter describes the basic operation of DMA transfer.

32B.9.13.1 Transfer modes

DMAC supports only single transfer mode.

Upon receiving a DMA transfer request from USB control, DMAC executes a single DMA transfer on the side (source or destination) indicated by the REQD bit in the CHCFG_n register. DMAC then asserts internal DMA permission from internal USB control to DMAC control. DMAC performs a single transfer each time a transfer is received. DMAC continues this operation by the transfer size loaded to the CRTB_n register (arbitration between channels is performed for each DMA transfer).

The timing of internal DMA permission from internal USB control to DMAC control differs depending on the setting of the REQD bit in the CHCFG_n register and the setting of the transfer size (DDS[2:0] and SDS[2:0] in the CHCFG_n register). For details, see **Section 32B.9.13.7, Operational difference depending on the transfer size.**

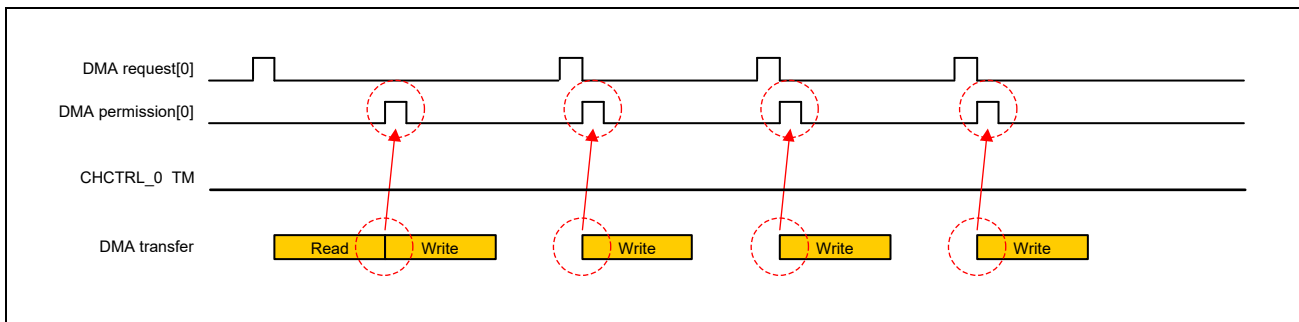

Figure 32B.23 Single Transfer Mode (REQD = 1, SDS > DDS)

32B.9.13.2 DMA channel priority control

DMAC supports fixed-priority mode and round-robin mode as methods of arbitration between channels. The mode is selected by using the PR bit in the DCTRL register. If the PR bit is 0, fixed-priority mode is selected. If the PR bit is 1, round-robin mode is selected.

Table 32B.51 Priority Control Setting

Mode	PR (DCTRL)	Description	Remarks
Fixed-priority	0	Controls requests based on fixed priority (CH0 > CH1 > ...).	Use this mode if channels have priority.
Round-robin	1	Controls requests in a round-robin manner.	Use this mode to execute requests equally.

(1) Fixed-priority mode

In fixed-priority mode, a fixed priority level is assigned to each channel as shown below.

(High) CH0 > CH1 (Low)

If DMA transfer requests simultaneously occur over multiple channels, the DMA transfer over the channel whose number is smallest is performed first.

The transfer over channel 0 is performed first. However, while a transfer switches to another transfer over channel 0, a transfer over the channel with the next highest priority level is performed in order to increase the bus usage rate.

(2) Round-Robin Mode

In round-robin mode, each time a transfer over a channel is received, the priority level of the channel that was used for the previous transfer is changed to the lowest level.

In the status immediately after the mode is reset, channels are assigned priority levels in the same way as fixed-priority mode as shown below.

(High) CH0 > CH1 (Low)

In this status, if a transfer request for DMA channel 0 does not occur and a transfer request for DMA channel 1 occurs, the transfer over DMA channel 1 is performed. When the transfer finishes, the channel priority is changed as follows.

(High) CH1 > CH0 (Low)

The following shows an example of DMA transfer in round-robin mode.

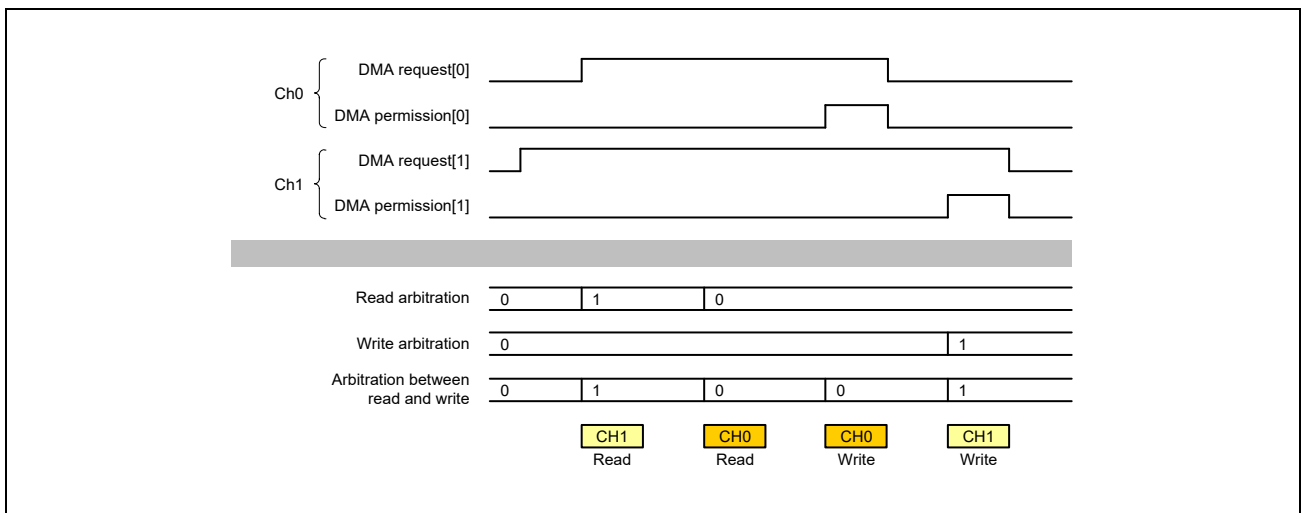

Figure 32B.24 Example of Operation in Round-Robin Mode (with 4 channels, REQD = 1)

DMAC internally performs arbitration between read channels and arbitration between write channels, further performs arbitration between the arbitration results, and then issues bus access.

32B.9.13.3 Forced sweeping request

When a forced sweeping request is entered, DMAC transfers the data that is left untransferred in the buffer to the destination address. After the sweep processing finishes, DMAC continues DMA transfer.

The following provides notes on forced sweeping requests:

- (1) If a forced sweeping request and a transfer request from USB control contend, DMAC performs forced sweeping first, and then performs a DMA transfer.
- (2) If the USB-control-side system is the destination (REQD bit in the CHCFG_n register is 1) register REQD = 1, buffer overflow or another error might occur on the destination unit because data is transferred although no DMA transfer request is made on the USB control side. Therefore, the specifications physically prohibit DMAC from using forced sweeping if REQD = 1.
- (3) The difference from ordinary sweeping mode described in **Section 32B.9.13.8(3)(b), Transfer suspension (buffer sweeping enabled: SBE = 1)** (EN is cleared by setting 1 for the SBE bit in the CHCFG_n register) is as follows: DMAC stops operation after writing data in the buffer in ordinary sweeping mode, whereas DMAC can continue DMA transfer after sweeping the buffer in forced sweeping mode.

(1) Forced software sweeping request

The SETSSWPRQ bit in the CHCTRL_n register determines whether software-based forced sweeping requests can be used. To perform a forced sweeping request, write 1 to the SETSSWPRQ bit. DMAC then outputs the data in the buffer to the destination.

32B.9.13.4 DMA transfer completion interrupt (USBFDMAm_n)

USBFDMA_m (m, n = 0, 1) is an interrupt signal that indicates termination of a DMA transaction.

If a transfer for the total number of transfer bytes loaded to the CRTB_n register is completed by an OKAY response, the END bit in the CHSTAT_n register is set to 1. At this time, if the DEM bit in the CHCFG_n register is 0, DMAC generates a USBFDMA_m (m, n = 0, 1) interrupt.

(If a write-back operation is performed in link mode, the interrupt is generated after the write-back operation finishes.)

In link mode, when the DRRP bit in the CHCFG_n register is 0, if the LV bit of the header of the descriptor that is read is 0, the DER bit in the CHSTAT_n register is set to 1. At this time, if the DIM bit in the CHCFG_n register is 0, DMAC generates a USBFDMA_m interrupt.

Use this signal to detect a transfer completion interrupt performed by the interrupt controller.

Table 32B.52 USBFDMA_m Assertion Conditions

Cause	Condition	INT_DMA[n] mask signal
DMA transaction ended	A transfer of data by the number of transfer bytes loaded to the CRTB _n register is completed by an OKAY response (if a write-back operation is performed in link mode, after the operation finishes)	DEM bit in the CHCFG _n register
Descriptor was invalid	LV of header of the descriptor that is read is 0 when DRRP and DIM in the CHCFG _n register are both 0 in link mode	DIM bit in the CHCFG _n register

32B.9.13.5 DMA error interrupt (USBFDMAERR_m)

If an error response is received for DMA transfer or descriptor access, this module stops transfer, assuming that an error occurred. When an error response is received, the EN bit in the CHSTAT_n register for channel n that is being used for transfer is cleared to 0, and the ER bit is set to 1 (n = 1, 0). Also, the USBFDMAERR_m interrupt is asserted.

The USBFDMAERR_m signal cannot be masked.

For a sequence of transfers for which an error occurred, data integrity cannot be guaranteed. Always use the following procedure to restart the transfer sequence from the beginning.

1. Set the SWRST bit in the CHCTRL_n register to 1.
2. Reset each register.

32B.9.13.6 Interval Count Function

The execution interval of a DMA transfer can be adjusted by using the ITVL field in the CHITVL_n register. This function prevents DMAC from continuously occupying the bus. If this function is enabled, DMAC does not perform a DMA transfer for the next request until the counter value becomes 0.

The following shows an operation example.

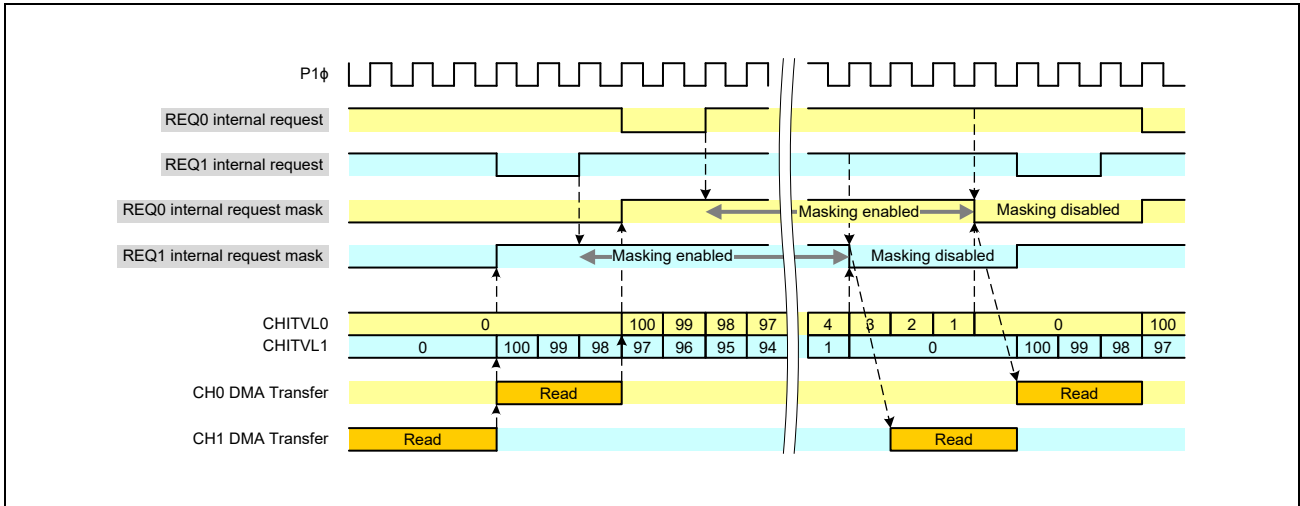

Figure 32B.25 Example of Counting Intervals (REQD = 0, SDS < DDS)

An interval is inserted after a transfer is performed on the side specified by the REQD bit in the CHCFG_n register. The following shows how the REQD, SDS, and DDS values of the CHCFG_n register are related with the interval.

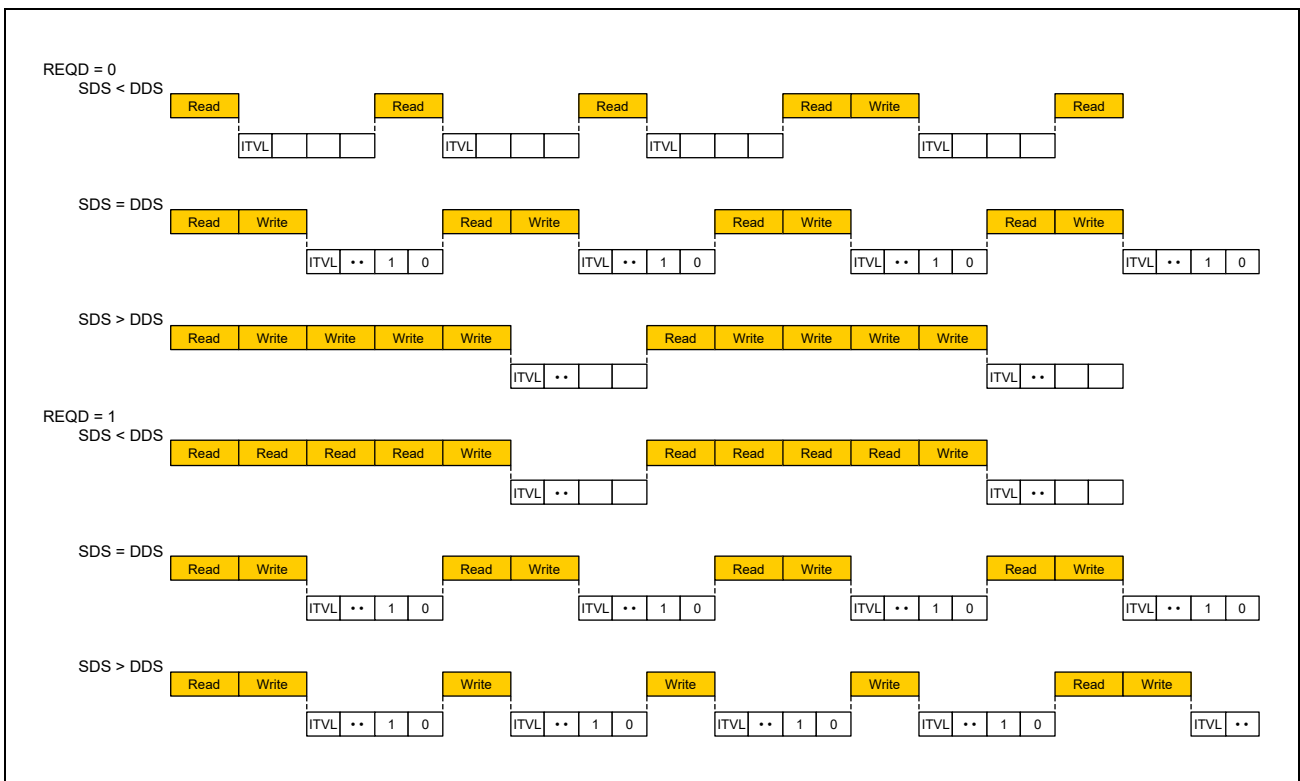

Figure 32B.26 DMA Transfer Settings and Interval Count

32B.9.13.7 Operational difference depending on the transfer size

(1) If the transfer size on the source side is smaller

When reading of as much data as the destination data size finishes, a write to the destination starts.

The following figure is an example of the timing chart in the case where the source is an 8-bit field and the destination is a 32-bit field (SDS = 0 and DDS = 2 in the CHCFG_n register) (when the rising edge is detected).

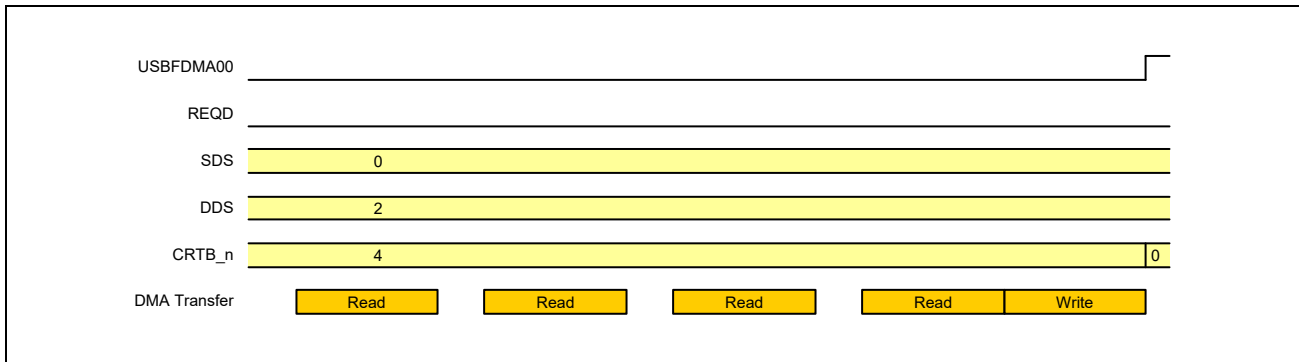

Figure 32B.27 Example of Timing Chart in the Case Where the Source is Smaller
(LVL = 0, HIEN = 1, REQD = 0, and SDS < DDS)

(2) If the transfer size on the destination side is smaller

Because the source side is larger than the destination side, two or more destination write operations occur for one source read operation. The following is an example of the timing chart in the case where the source is a 64-bit field and the destination is a 16-bit field (SDS = 3 and DDS = 1 in the CHCFG_n register) (when the rising edge is detected).

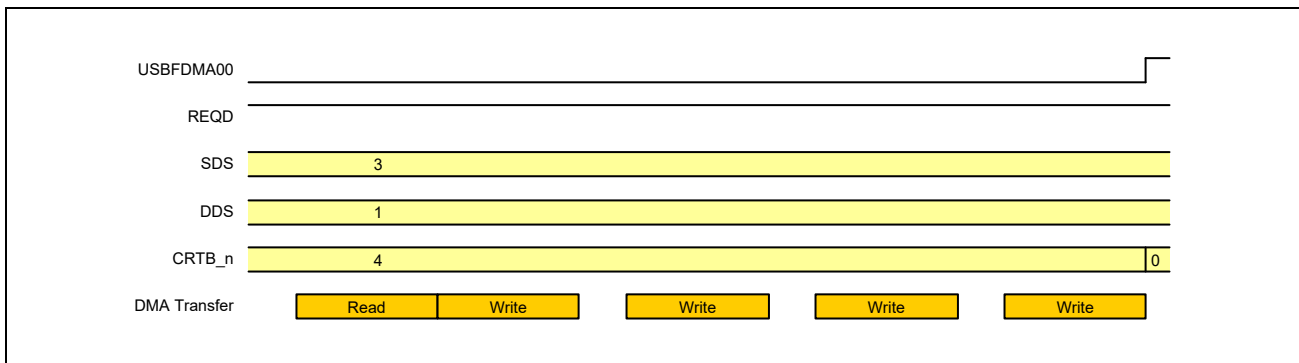

Figure 32B.28 Example of Timing Chart in the Case Where the Destination Is Smaller
(LVL = 0, HIEN = 1, REQD = 1, and SDS > DDS in the CHCFG_n Register)

(3) If the Source and Destination Transfer Sizes Are the Same

Each time a DMA transfer request is detected, a source read operation and a destination write operation occur.

The following is an example of the timing chart in the case where the source and destination are 8-bit fields (SDS = 0 and DDS = 0 in the CHCFG_n register) (when the rising edge is detected).

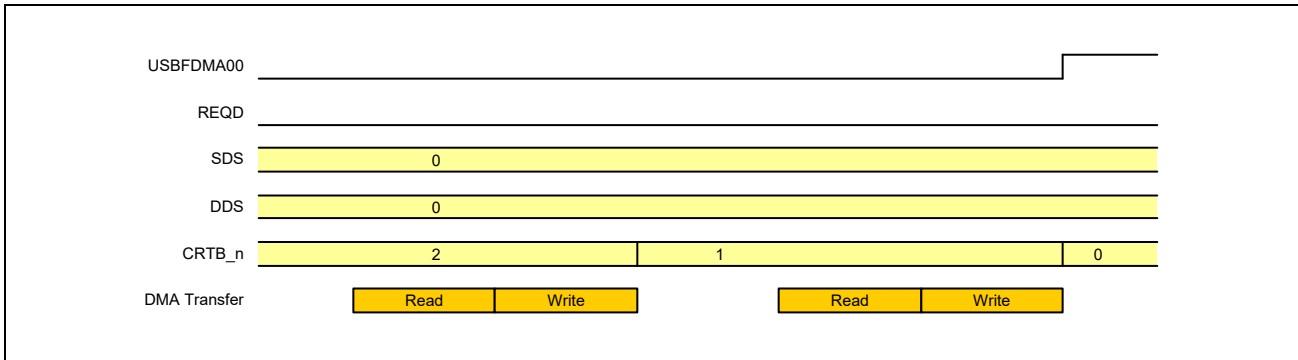

Figure 32B.29 Example of Timing Chart in the Case where the Source and Destination Sizes are the Same (LVL = 0, HIEN = 1, REQD = 0, and SDS = DDS in the CHCFG_n Register)

32B.9.13.8 Transfer state

The CHSTAT_n register indicates the transfer state of a channel.

(1) Transfer state

The TACT bit in the CHSTAT_n register indicates that channel n is operating. When 1 is written to the SETEN bit in the CHCTRL_n register, the TACT bit is set to 1. The TACT bit continues to be 1 while DMAC is accessing a descriptor or waiting for a DMA request.

The TACT bit is cleared when the EN bit in the CHSTAT_n register is cleared (for details about the conditions in which the EN bit is cleared, see **Section 32B.4.1, Current Source Address Register**) and the DMA transfer ends.

If the EN bit is not cleared when the DMA transaction ends (for example, when the REN bit of the CHCFG_n register is 1 in register mode or when DMAC accesses the next descriptor in link mode), the TACT bit is not cleared.

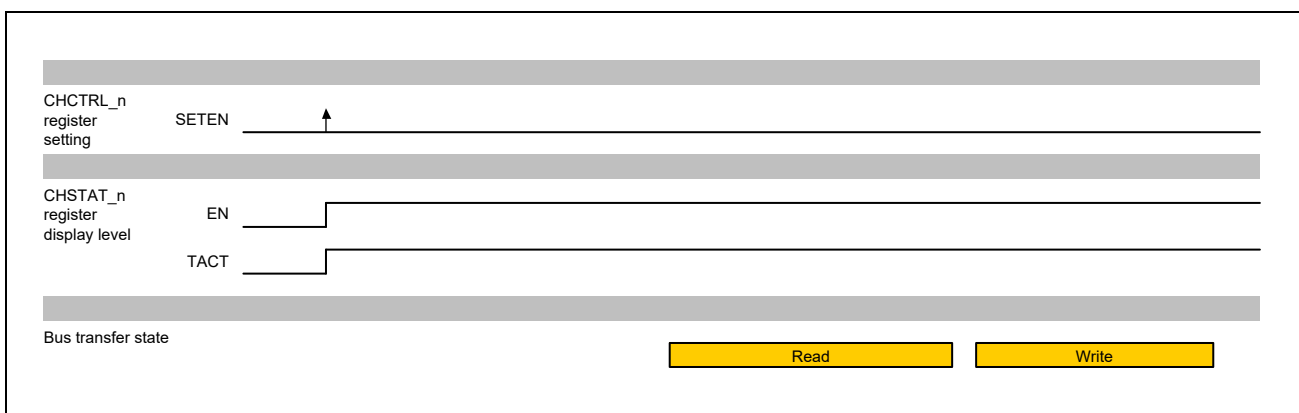

Figure 32B.30 DMAC State Example 1 (Hardware Request)

(2) Suspension

The SETSUS bit in the CHCTRL_n register can be used to suspend a DMA transfer. If suspension of a DMA transfer is attempted when a bus cycle is running, the DMA transfer is suspended after the bus cycle finishes. The suspended transfer can be resumed by writing 1 to the CLRSUS bit in the CHCTRL_n register.

To check whether a DMA transfer is suspended, after setting the SETSUS bit in the CHCTRL_n register, check the SUS bit in the CHSTAT_n register or the SUS bit for the relevant channel in the DSTAT_SUS register. If The SUS bit is 1, the DMA transfer is currently suspended.

(3) Transfer suspension

By writing 1 to the CLREN bit in the CHCTRL_n register during a DMA transaction, the DMA transaction of the channel can be suspended. As the post-processing for suspension, the SBE bit in the CHCFG_n register can be used to select whether to sweep the data remaining in the buffer when the transaction is suspended. The default is SBE = 0 (do not sweep remaining data).

If the sweep mode is enabled and a transfer is suspended by setting 1 for the CLREN bit in the CHCTRL_n register, DMAC sweeps any data remaining in the buffer and stops operation.

(a) Transfer suspension (buffer sweeping disabled: SBE = 0)

If 1 is written to the CLREN bit in the CHCTRL_n register during DMA transfer, DMAC suspends DMA transfer and then stops. The timing of stoppage depends on the value set for the REQD bit. After DMAC stops, write 1 to the SWRST bit in the CHCTRL_n register to clear the internal status of DMAC, and then specify the next transfer settings.

Complete deactivation of the channel can be confirmed when the value of the TACT bit in the CHSTAT_n register changes from 1 to 0.

If DMA transfer is suspended before it is completed, the USBFDMAmn interrupt is not asserted.

If the REQD bit in the CHCFG_n register is 0, DMAC stops when the next read operation is completed. However, if data that can be written exists in the buffer, DMAC writes the data and then stops.

If the REQD bit in the CHCFG_n register is 1, DMAC stops when the next read operation is completed.

(b) Transfer suspension (buffer sweeping enabled: SBE = 1)

If 1 is written to the CLREN bit in the CHCTRL_n register during DMA transfer, DMAC suspends DMA transfer. If the REQD bit in the CHCFG_n register is 0, DMAC sweeps (writes) the already read data, and then stops DMA transfer. If the REQD bit is 1, sweep mode cannot be used physically.

After DMAC stops, set the SWRST bit in the CHCTRL_n register to clear the internal status of DMAC, and then specify the next transfer settings.

Complete deactivation of the channel can be confirmed when the value of the TACT bit in the CHSTAT_n register changes from 1 to 0.

(c) How to confirm deactivation of the channel

Even when the EN bit of the CHSTAT_n register is cleared to 0 by writing 1 to the CLREN bit in the CHCTRL_n register, if a transfer has already been executed over the bus, DMAC cannot immediately stop. To check whether DMAC has stopped completely, check the EN and TACT bits in the CHSTAT_n register. If both bits are 0, DMAC has stopped completely.

(d) Procedure for suspending transfer

To suspend transfer:

1. Write 1 to the CLREN bit in the CHCTRL_n register.
2. If the SBE bit in the CHCFG_n register is 0, DMAC stops according to the value of the REQD bit in the CHCFG_n register. If the SBE bit is 1, DMAC is placed in sweep mode.
3. Read the CHSTAT_n register to check whether the TACT bit is 0. If the TACT bit is 0, DMAC has stopped completely. If the TACT bit is 1, continue polling until the bit changes to 0.
4. To perform the next DMA transfer after it is suspended, make sure that the SWRST (software reset) bit in the CHCTRL_n register is turned on before the next DMA transfer starts.

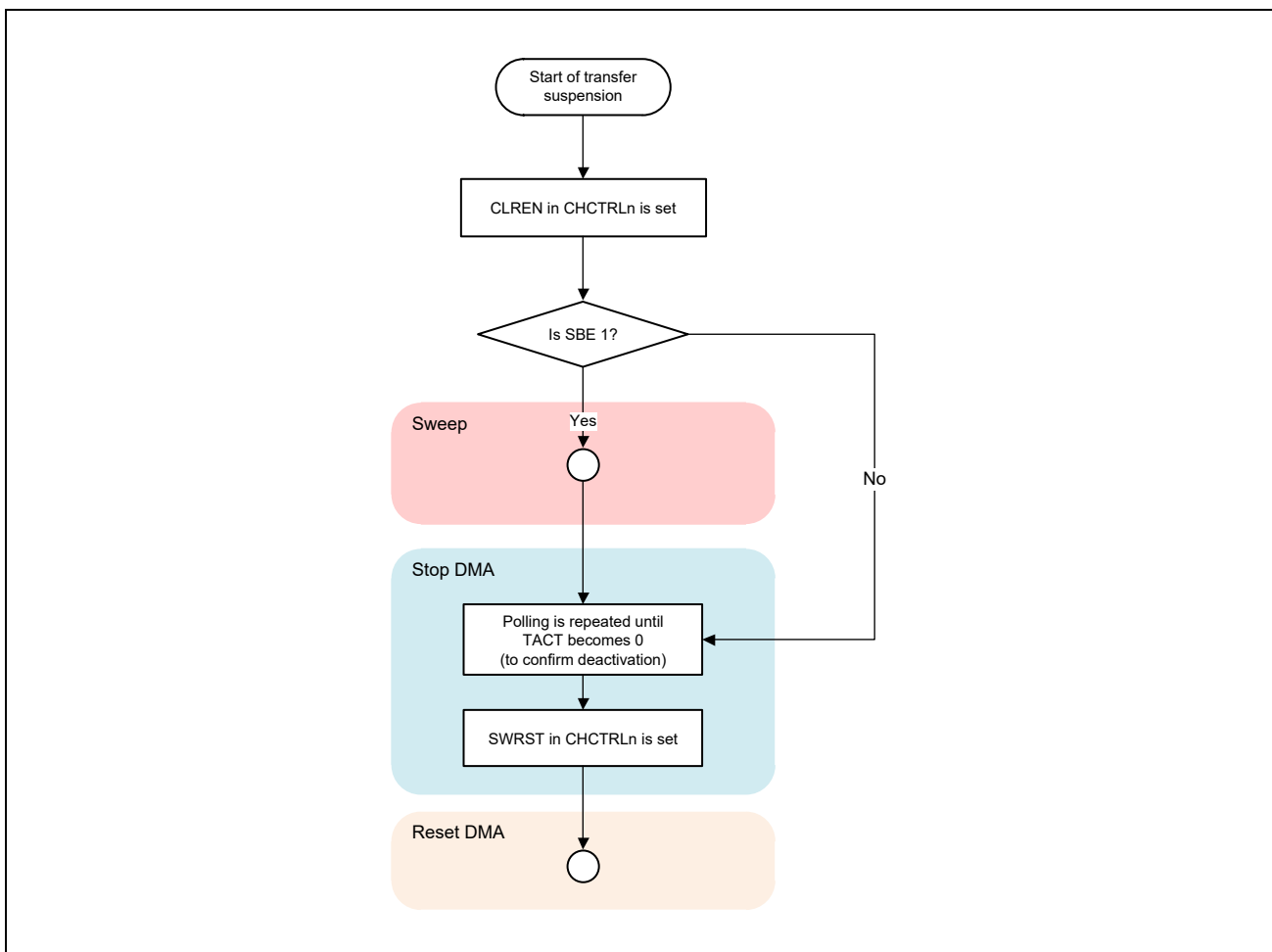

Figure 32B.31 Transfer Suspension Flowchart

32B.9.14 Access Type

32B.9.14.1 DMA master transfer combination list

(1) Read access

The following describes characteristics of the issuance type for DMA read access.

- An access is performed for a beat align space whose size is set by SDS[2:0] in the CHCFG_n register, including the source address indicated in the CRSA_n register. A beat unaligned transfer for the bus is not performed. An excess area is sometimes read depending on CRSA_n or SKIP settings. In this case, the necessary data is imported into the buffer from the read data.
- The size and burst length are determined based on the value set in the SDS[2:0] field.
 - If the value set in the SDS[2:0] field is equal to or less than the bus width
 - Size: Value set in SDS[2:0]
 - Burst type: SINGLE
 - If the value set in the SDS[2:0] field is larger than the bus width
 - Size: Bus width
 - Burst type: Fixed-length burst (burst length = SDS[2:0] value/bus width)

The following indicates the access types for the bus.

Table 32B.53 DMA Read Transfer Combination List

SDS	Source Address	AHB transfer					
		First transfer			Second transfer		
		Address	Data Size	Burst Type	Address	Data Size	Burst Type
0 (8 bits)	-	addr	8	SINGLE			
1 (16 bits)	2 byte align	{addr[31:1], 0b}	16	SINGLE			
	2 byte unalign				{addr[31:1], 0b} + H'2	16	SINGLE
2 (32 bits)	4 byte align	{addr[31:2], 00b}	32	SINGLE			
	4 byte unalign				{addr[31:2], 00b} + H'4	32	SINGLE
4 (128 bits)	16 byte align	{addr[31:4], H'0}	32	INCR4			
	16 byte unalign				{addr[31:4], H'0} + H'10	32	INCR4
5 (256 bits)	32 byte align	{addr[31:5], H'00}	32	INCR8			
	32 byte unalign				{addr[31:5], H'00} + H'20	32	INCR8
6 (512 bits)	64 byte align	{addr[31:6], H'00}	32	INCR16			
	64 byte unalign				{addr[31:6], H'00} + H'40	32	INCR16

Note: If EBT is detected in the middle of burst, 32-bit INCR burst is used to transfer the remaining data.

(2) Write access

The following describes characteristics of the issuance type for DMA write access.

- An access is performed from the destination address indicated by the CRDA_n register to the beat align boundary whose size is set by DDS[2:0] in the CHCFG_n register.
- The size and burst length are determined based on the value set in the DDS[2:0] field.
 - If the value set in the DDS[2:0] field is equal to or less than the bus width
 - Size: Value set in DDS[2:0]
 - Burst type: SINGLE
 - If the value set in the DDS[2:0] field is greater than the bus width
 - Size: Bus width
 - Burst type: Fixed-length burst (burst length = DDS[2:0] value/bus width)
- In write access, only the specified space is accessed. In the following cases, the combination of values smaller than the value set in the DDS[2:0] field is used for access.
 - The destination address is beat-unaligned for the value set in the DDS[2:0] field.
 - An access specified in the DDS field will be across the SKIP boundary.
 - The size specified in the DDS[2:0] field is too large for the number of remaining bytes to be transferred.

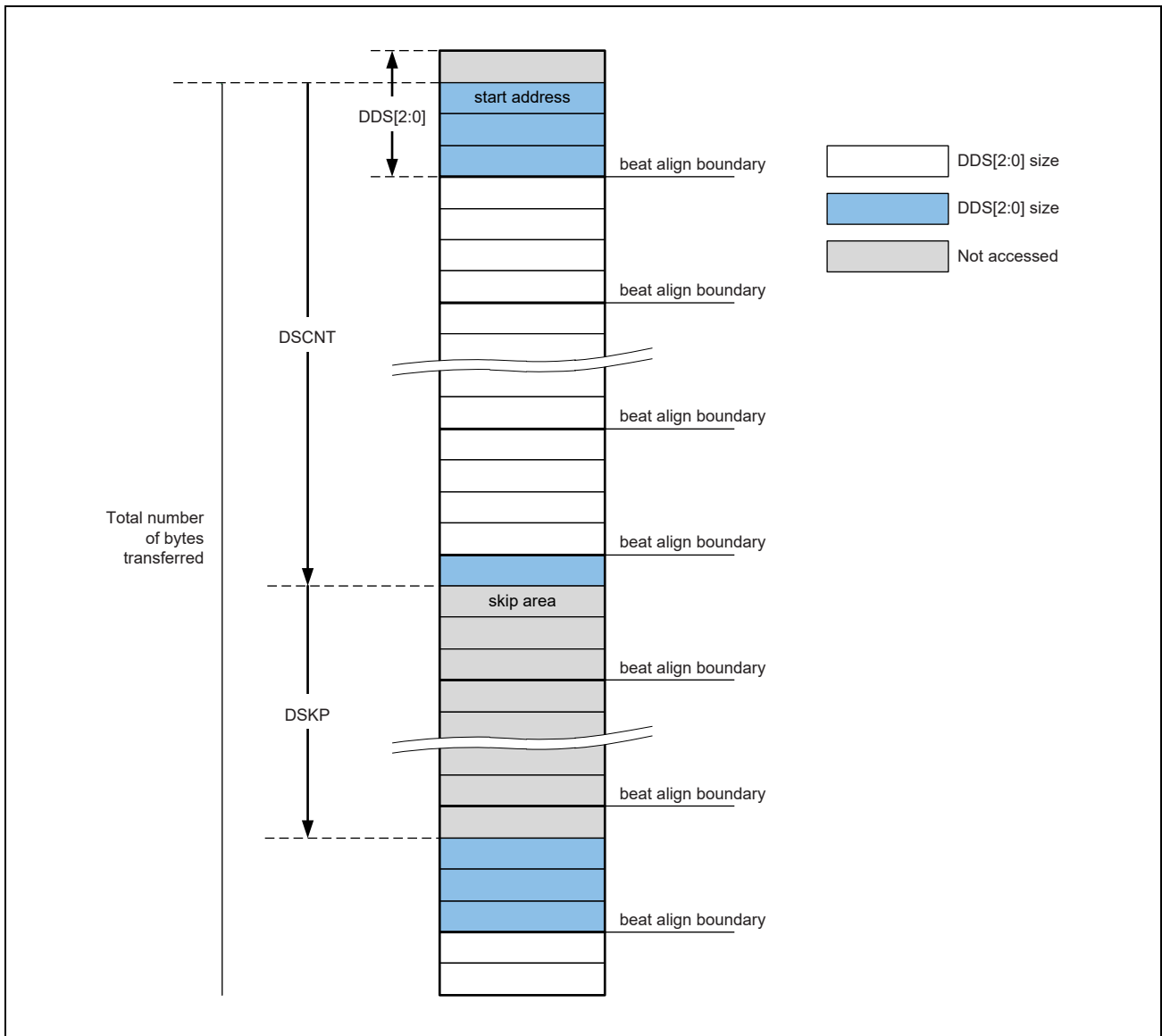

Figure 32B.32 Example of DMA Write Access Space and Access Types

The following shows the access types for the bus in the case of beat-aligned.

Table 32B.54 DMA Write Transfer Combination List

AHB transfer			
First transfer			
DDS[2:0]	Address	Data Size	Burst Type
0 (8 bits)	addr	8	SINGLE
1 (16 bits)	{addr[31:1], 0b}	16	SINGLE
2 (32 bits)	{addr[31:2], 00b}	32	SINGLE
4 (128 bits)	{addr[31:4], H'0}	32	INCR4
5 (256 bits)	{addr[31:5], H'00}	32	INCR8
6 (512 bits)	{addr[31:6], H'00}	32	INCR16

32B.9.14.2 DMA master descriptor combination list

(1) Read access

The following describes characteristics of a descriptor access.

- Accesses are performed for 8-word beat align space including the LINK address (the address indicated in the CRLA_n register). A beat unaligned transfer is not performed.
- The size and burst length set by INCR8 are used.
- The descriptor format (DSCFM) of the read header is analyzed, and then the descriptor data is set in an internal register.
- If the descriptor extends over the 8-word boundary, an additional read is performed on the succeeding eight words.

The following indicates the types of access to the bus.

Table 32B.55 Descriptor Read Transfer Combination List

Descriptor Format	Address		AHB Transfer					
	addr[4:0]	Address	First Transfer			Second Transfer		
			Address	Size	Burst	Address	Size	Burst
4 words	H'00	{addr[31:4], 0000b}		32	INCR8			
	H'04							
	H'08							
	H'0C							
	H'10							
	H'14					{addr[31:4], 0000b} + H'20	32	INCR8
	H'18							
	H'1C							
8 words	H'00							
	H'04					{addr[31:4], 0000b} + H'20	32	INCR8
	H'08							
	H'0C							
	H'10							
	H'14							
	H'18							
	H'1C							

Note: If EBT is detected in the middle of burst, 32-bit INCR burst is used to transfer the remaining data.

(2) Write access

Use single transfer as the issuance type for writing data back to a descriptor. The following indicates the types of access to the bus.

Table 32B.56 Descriptor Write Transfer Combination List

Type	AHB transfer		
	Address	Size	Burst
Write-back in normal mode	{addr[31:2], 00b} + H'3	8	SINGLE
Write-back in the case of an error	{addr[31:2], 00b} + H'2	8	SINGLE

32B.9.15 Arbitration between DMACs

Arbitration between internal DMACs is performed in round-robin mode.

In round-robin mode, the highest priority is given to the DMAC whose DMAC number is the DMAC number being used for transfer + 1. Immediately after a reset, DMAC0 has the highest priority.

Table 32B.57 Priority of a transfer request for DMACs that are performing transfer

Current DMAC	Next DMAC	
	DMAC0	DMAC1
DMAC0	2	1
DMAC1	1	2

Note: Priority: 1 (high), 2 (low)

32B.9.16 Notes

32B.9.16.1 Access

During read access, a beat align area is accessed by one transfer. Therefore, if beat unaligned is set, the beat align area including the specified area is accessed.

For example, if the Source Address is H'0000_1038 and SDS is 5 (256-bit), read starts from area H'0000_1020, not from address H'0000_1038. At this time, if the area from H'0000_1020 to H'0000_1037 contains a register whose value changes by read, the operation might be disrupted.

To prevent problems, use the beat align setting to access a register whose value changes by read access or access to an area adjacent to FIFO.

32B.9.16.2 Level Interrupt bit

This is a DMA interrupt output enable bit. Always set this bit to 1 irrespective of whether peripheral module interrupt USBFDMAm (m, n = 0, 1) or USBFDMAERRm (m = 0, 1) is used.

To use peripheral module interrupt USBFDMAm or USBFDMAERRm, set this bit to 1, and then set up the interrupt controller.

40. SD/MMC Host Interface

NOTE

Development of the SD host--related products needs the conclusion of the following agreement. SD Host/Ancillary Product License Agreement (SD HALA)

40.1 Overview

40.1.1 Features

- 2 channels
- Channel 0 supports SDHI / e-MMC
- Channel 1 supports SDHI
- SD memory/IO card interface (1-bit/4-bit SD bus)
- SD, SDHC, and SDXC SD memory card access supported
- Default, high-speed, UHS-I/SDR50, and SDR104 transfer modes supported
- SD clock (SD_CLK) frequency = $SDx\phi/4$ frequency/ 2^n ($n = 0$ to 9) ($x = 0, 1$)
- Error check function: CRC7 (for command/response), CRC16 (for data)
- Interrupt request: 2
- Card detect function
- Write protect supported
- MMC interface (1-/4-/8-bit MMC bus)
- e-MMC device access supported
- Backward-compatible, high-speed, HS200 transfer modes supported
- High-priority interrupt (HPI) supported

Block Diagram

Figure 40.1 shows a block diagram of the SD/MMC host interfaces.

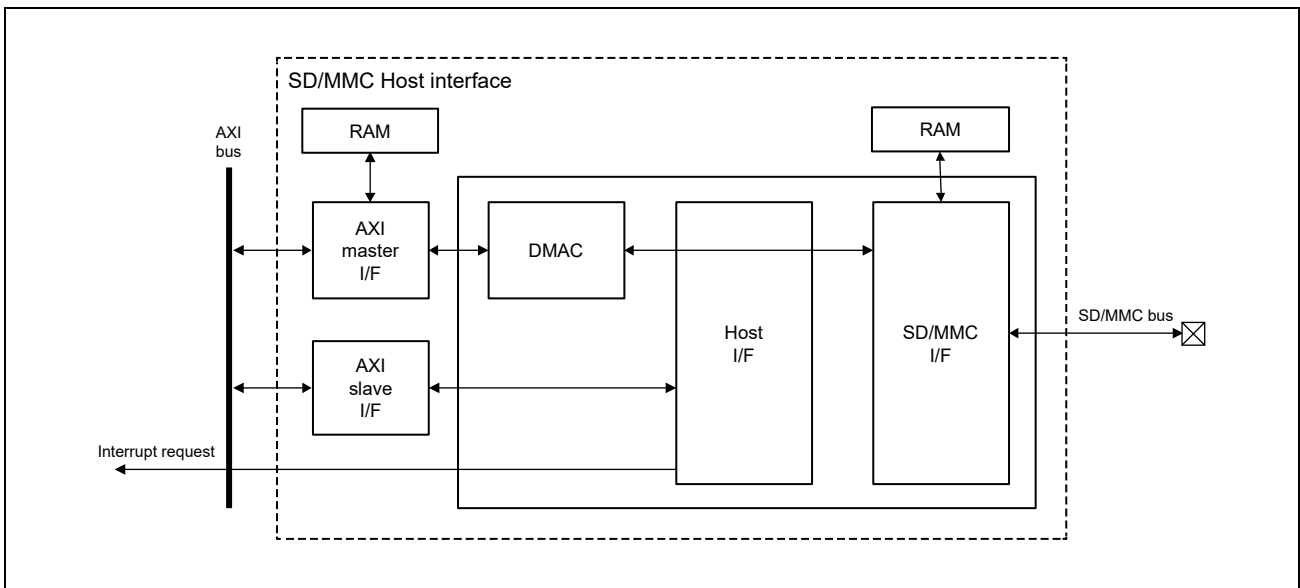

Figure 40.1 Block Diagram of SD/MMC Host Interface

40.1.2 External Pins

Table 40.1 lists the input and output pins used by the interface. The operating voltage on the pins of the SD/MMC host interface is 3.3 V or 1.8 V. Channels 0 and 1 can operate with different voltages. Before using the pins of the SD/MMC host interface, be sure to set the SD ch0/1 IO Voltage Mode Control Register (SD_ch0 and SD_ch1) and Driving Ability Control Register (IOLH).

For details, see the following sections:

Section 41.3.7, Driving Ability Control Register,
Section 41.3.17, SD ch0 IO Voltage Mode Control Register,
Section 41.3.18, SD ch1 IO Voltage Mode Control Register.

Table 40.1 Pin Configuration

PIN Name	I/O	Function
SDx_CLK* ¹	O	SD/MMC clock output
SDx_CMD* ¹	I/O	SD/MMC command output, response input
SDx_DATA0* ¹	I/O	SD/MMC Data 0 [bit 0]
SDx_DATA1* ¹	I/O	SD/MMC Data 1 [bit 1], SDIO interrupt
SDx_DATA2* ¹	I/O	SD/MMC Data 2 [bit 2], read wait
SDx_DATA3* ¹	I/O	SD/MMC Data 3 [bit 3], Card detection
SD0_DATA4* ¹	I/O	SD/MMC Data 4 [bit 4],
SD0_DATA5* ¹	I/O	SD/MMC Data 5 [bit 5]
SD0_DATA6* ¹	I/O	SD/MMC Data 5 [bit 6]
SD0_DATA7* ¹	I/O	SD/MMC Data 7 [bit 7]
SDx_CD* ¹	I	SD/MMC card detection* ²
SDx_WP* ¹	I	SD/MMC write protection* ²
SD0_RST#	O	SD/MMC reset

Note 1. x (= 0, 1) is the channel number of the SD/MMC host interface. In this manual, those pins are referred as SDDAT0, SDDAT1, ..., SDDAT7.

Note 2. Fix to 1 when not in use.

40.1.3 Register Configuration

The base addresses for each channel are as follows. The SD interface and MMC interface are switched by setting the command type register (SD_CMD).

Channel 0:

H'0_11C0_0000 (AX45MP Address Space)

Channel 1:

H'0_11C1_0000 (AX45MP Address Space)

Table 40.2 Register Configurations (1/2)

Name	Abbreviation	Address	Access Width	Mirror
Command type register	SD_CMD	H'0000	16/32/64	
Command argument registers	SD_ARG	H'0010	16/32/64	
	SD_ARG1	H'0018	16/32/64	SD_ARG[31:16]
Data stop register	SD_STOP	H'0020	16/32/64	
Block count register	SD_SECCNT	H'0028	16/32/64	
Card response registers	SD_RSP10	H'0030	16/32/64	
	SD_RSP1	H'0038	16/32/64	SD_RSP10[31:16]
	SD_RSP32	H'0040	16/32/64	SD_RSP10[63:32]
	SD_RSP3	H'0048	16/32/64	SD_RSP32[31:16]
	SD_RSP54	H'0050	16/32/64	
	SD_RSP5	H'0058	16/32/64	SD_RSP54[31:16]
	SD_RSP76	H'0060	16/32/64	SD_RSP54[63:32]
	SD_RSP7	H'0068	16/32/64	SD_RSP76[31:16]
SD card interrupt flag register 1	SD_INFO1	H'0070	16/32/64	
SD card interrupt flag register 2	SD_INFO2	H'0078	16/32/64	
SD_INFO1 interrupt mask register	SD_INFO1_MASK	H'0080	16/32/64	
SD_INFO2 interrupt mask register	SD_INFO2_MASK	H'0088	16/32/64	
SD clock control register	SD_CLK_CTRL	H'0090	16/32/64	
Transfer data length register	SD_SIZE	H'0098	16/32/64	
Card access control option register	SD_OPTION	H'00A0	16/32/64	
SD error status register 1	SD_ERR_STS1	H'00B0	16/32/64	
SD error status register 2	SD_ERR_STS2	H'00B8	16/32/64	
SD buffer read/write register	SD_BUF0	H'00C0	16/32/64	
SDIO mode control register	SDIO_MODE	H'00D0	16/32/64	
SDIO interrupt flag register	SDIO_INFO1	H'00D8	16/32/64	
SDIO_INFO1 interrupt mask register	SDIO_INFO1_MASK	H'00E0	16/32/64	
DMA mode enable register	CC_EXT_MODE	H'0360	16/32/64	
Software reset register	SOFT_RST	H'0380	16/32/64	
Version register	VERSION	H'0388	16/32/64	
Host interface mode setting register	HOST_MODE	H'0390	16/32/64	
SD interface mode setting register	SDIF_MODE	H'0398	16/32/64	
SD status register*1	SD_STATUS	H'03C8	16/32/64	
DMAC mode register	DM_CM_DTRAN_MODE	H'0820	16/32/64	
DMAC control register	DM_CM_DTRAN_CTRL	H'0828	16/32/64	
DMAC reset register	DM_CM_RST	H'0830	16/32/64	

Table 40.2 Register Configurations (2/2)

Name	Abbreviation	Address	Access Width	Mirror
DMAC interrupt register 1	DM_CM_INFO1	H'0840	16/32/64	
DM_CM_INFO1 interrupt mask register	DM_CM_INFO1_MASK	H'0848	16/32/64	
DMAC interrupt register 2	DM_CM_INFO2	H'0850	16/32/64	
DM_CM_INFO2 interrupt mask register	DM_CM_INFO2_MASK	H'0858	16/32/64	
DMAC address register	DM_DTRAN_ADDR	H'0880	16/32/64	
SCC register area ^{*2}	—	—	—	—

Note 1. Only for channel 0.

Note 2. Refer to **Section 40.7, SCC Register Descriptions**.

40.2 Register Description

40.2.1 Command Type Register (SD_CMD)

The command type register (SD_CMD) is used to select the command type and response type. The command sequence is started by writing to SD_CMD.

For details on the SD_CMD setting, refer to **Section 40.4.14, Example of SD_CMD Register Setting**.

Bit	Bit Name	Initial Value	R/W	Description
63 to 16	—	All 0	R	These bits are always read as 0. The write value should always be 0. Operation is not guaranteed if a value other than 0 is written to these bits.
15	MD7	00	R/W	Multiple Block Transfer Mode (enabled at multiple block transfer) 00: CMD12 is automatically issued at multiple block transfer. 01: CMD12 is not automatically issued at multiple block transfer. 10: Setting prohibited 11: Setting prohibited
14	MD6			
13	MD5	0	R/W	Single/Multiple Block Transfer (enabled when the command with data is handled) 0: Single block transfer 1: Multi block transfer
12	MD4	0	R/W	Write/Read Mode (enabled when the command with data is handled) 0: Write (SD/MMC host interfaces -> SD card) 1: Read (SD/MMC host interfaces <- SD card)
11	MD3	0	R/W	Data Mode (Command Type) 0: Command without data transfer (bc, bcr, ac) 1: Command with data transfer (adtc)
10	MD2	000	R/W	Mode/Response Type 000: Normal mode The response type and the transfer mode are selected by SD_CMD[7:0], and the SD_CMD[15:11] setting is disabled. 001: Setting prohibited 010: Setting prohibited 011: Extended mode/No response 100: Extended mode/R1, R5, R6, or R7 response from the SD card 101: Extended mode/R1b response from the SD card 110: Extended mode/R2 response from the SD card 111: Extended mode/R3 or R4 response from the SD card Some commands cannot be used in normal mode. For details, see Section 40.4.14, Example of SD_CMD Register Setting to select mode/response type.
9	MD1			
8	MD0			
7	C1	00	R/W	00: CMD 01: ACMD 10: Setting prohibited 11: Setting prohibited
6	C0			
5	CF45	000000	R/W	Command Index These bits specify Command Format[45:40] (command index). [Examples] CMD6: SD_CMD[7:0] = 0000 0110b CMD18: SD_CMD[7:0] = 0001 0010b ACMD13: SD_CMD[7:0] = 0100 1101b
4	CF44			
3	CF43			
2	CF42			
1	CF41			
0	CF40			

Note: SD_CMD cannot be written to when the CBSY bit in SD_INFO2 is 1.

40.2.2 Command Argument Register (SD_ARG)

Command arguments for SD cards are set in the SD command argument registers (SD_ARG). Set the command arguments before writing to SD_CMD.

Note that the argument of CMD12 within command sequences is H'0000 0000 regardless of the setting of SD_ARG.

SD_ARG

Bit	Bit Name	Initial Value	R/W	Description
63 to 32	—	All 0	R	Reserved These bits are always read as 0. The write value should always be 0. Operation is not guaranteed if a value other than 0 is written to these bits.
31 to 0	CF39 to CF8	All 0	R/W	Set command format[39:8] (argument).

SD_ARG1 (Mirror of SD_ARG[31:16])

Bit	Bit Name	Initial Value	R/W	Description
63 to 16	—	All 0	R	Reserved These bits are always read as 0. The write value should always be 0. Operation is not guaranteed if a value other than 0 is written to these bits.
15 to 0	CF39 to CF24	All 0	R/W	Set command format[39:24] (argument).

40.2.3 Data Stop Register (SD_STOP)

The data stop register (SD_STOP) is used to enable or disable block counting at multiple block transfer, and to control the issuing of CMD12 within command sequences.

Bit	Bit Name	Initial Value	R/W	Description
63 to 19	—	All 0	R	Reserved These bits are always read as 0. The write value should always be 0. Operation is not guaranteed if a value other than 0 is written to these bits.
18	—	0*1	R/W	Reserved The write value should always be 0.
17	HPIMODE	0*1	R/W	HPI Mode Enable 0: Disables HPI mode. 1: Enables HPI mode.
16	HPICMD	0*1	R/W*3	HPI Command Issue When HPICMD is set to 1 while HPIMODE is 1, the HPI command (CMD12) is issued. This bit is cleared to 0 when reception of the response to CMD12 is completed. The timing with which this bit is set to 1 is as follows. <ul style="list-style-type: none"> • After reception of the response to CMD12 that was issued by setting the STP bit to 1 has been completed during the CMD6/CMD38 or CMD25 sequence. • After reception of the response to CMD24/CMD25 has been completed After HPICMD is set to 1, do not write 0 to this bit while the CBSY bit in SD_INFO2 is 1. Do not set this bit to 1 when the CBSY bit in SD_INFO2 is 0.
15 to 9	—	All 0	R	Reserved These bits are always read as 0. The write value should always be 0. Operation is not guaranteed if a value other than 0 is written to these bits.
8	SEC	0*1	R/W	Block Count Enable*2 0: Disables SD_SECCNT setting value. 1: Enables SD_SECCNT setting value. Set SEC to 1 at multiple block transfer. When SD_CMD is set as follows to start the command sequence while SEC is set to 1, CMD12 is automatically issued to stop multi-block transfer with the number of blocks which is set to SD_SECCNT. <ol style="list-style-type: none"> 1. CMD18 or CMD25 in normal mode (SD_CMD[10:8] = 000) 2. SD_CMD[15:13] = 001 in extended mode (CMD12 is automatically issued, multiple block transfer) When the command sequence is halted because of a communications error or timeout, CMD12 is not automatically issued.
7 to 1	—	All 0	R	Reserved These bits are always read as 0. The write value should always be 0. Operation is not guaranteed if a value other than 0 is written to these bits.

Bit	Bit Name	Initial Value	R/W	Description
0	STP	0*1	R/W	<p>Stop</p> <ul style="list-style-type: none"> When STP is set to 1 during multiple block transfer, CMD12 is issued to halt the transfer through the SD/MMC host interface. However, if a command sequence is halted because of a communications error or timeout, CMD12 is not issued. Although continued buffer access is possible even after STP has been set to 1, the buffer access error bit (ERR5 or ERR4) in SD_INFO2 will be set accordingly. When STP has been set to 1 during transfer for single block write, the access end flag is set when SD_BUF becomes empty, and CMD12 is not issued. If SD_BUF does contain data, the access end flag is set on completion of reception of the busy state without CMD12 having been issued. When STP has been set to 1 during transfer for single block read, the access end flag is set immediately after setting of the STP bit and CMD12 is not issued. When STP is set to 1 during reception of the busy state after an R1b response, the access end flag is set on completion of reception of the busy state without CMD12 having been issued. When STP is set to 1 after a command sequence has been completed, CMD12 is not issued and the access end flag is not set. Set STP to 1 after the response end flag has been set. Set STP to 0 after the response end flag has been set.

Note 1. The initial value is applied at a reset and when the SDRST bit in SOFT_RST is 0.

Note 2. Do not change the value of this bit when the CBSY bit in SD_INFO2 is set to 1.

Note 3. It is effective only if 1 is written.

40.2.4 Block Count Register (SD_SECCNT)

The block count register (SD_SECCNT) is used to specify the number of transfer blocks at multiple block transfer.

Bit	Bit Name	Initial Value	R/W	Description
63 to 32	—	All 0	R	Reserved These bits are always read as 0. The write value should always be 0. Operation is not guaranteed if a value other than 0 is written to these bits.
31 to 0	CNT31 to CNT0	All 0	R/W	Number of Transfer Blocks*1 When H'0000 0001 is set, the number of transfer blocks is 1. : When H'0000 FFFF is set, the number of transfer blocks is 65535. : When H'FFFF FFFF is set, the number of transfer blocks is 4294967295. Do not set this register to H'0000 0000 if multiple blocks are to be transferred.

Note 1. Do not change the value of these bits when the CBSY bit in SD_INFO2 is set to 1.

40.2.5 SD Card Response Registers (SD_RSP)

The SD card response registers (SD_RSP) hold the response from the SD card.

SD_RSP10

Bit	Bit Name	Initial Value	R/W	Description
63 to 0	R71 to R8	All 0	R	Hold the response from the SD card

SD_RSP1 (Mirror of SD_RSP10[31:16])

Bit	Bit Name	Initial Value	R/W	Description
63 to 16	—	All 0	R	Reserved These bits are always read as 0. The write value should always be 0. Operation is not guaranteed if a value other than 0 is written to these bits.
15 to 0	R39 to R24	All 0	R	Hold the response from the SD card

SD_RSP32 (Mirror of SD_RSP10[63:32])

Bit	Bit Name	Initial Value	R/W	Description
63 to 32	—	All 0	R	Reserved These bits are always read as 0. The write value should always be 0. Operation is not guaranteed if a value other than 0 is written to these bits.
31 to 0	R71 to R40	All 0	R	Hold the response from the SD card

SD_RSP3 (Mirror of SD_RSP32[31:16])

Bit	Bit Name	Initial Value	R/W	Description
63 to 16	—	All 0	R	Reserved These bits are always read as 0. The write value should always be 0. Operation is not guaranteed if a value other than 0 is written to these bits.
15 to 0	R71 to R56	All 0	R	Hold the response from the SD card

SD_RSP54

Bit	Bit Name	Initial Value	R/W	Description
63 to 56	—	All 0	R	These bits are always read as 0. The write value should always be 0. Operation is not guaranteed if a value other than 0 is written to these bits.
55 to 0	R127 to R72	All 0	R	Hold the response from the SD card

SD_RSP5 (Mirror of SD_RSP54[31:16])

Bit	Bit Name	Initial Value	R/W	Description
63 to 16	—	All 0	R	Reserved These bits are always read as 0. The write value should always be 0. Operation is not guaranteed if a value other than 0 is written to these bits.
15 to 0	R103 to R88	All 0	R	Hold the response from the SD card

SD_RSP76 (Mirror of SD_RSP54[63:32])

Bit	Bit Name	Initial Value	R/W	Description
63 to 24	—	All 0	R	Reserved These bits are always read as 0. The write value should always be 0. Operation is not guaranteed if a value other than 0 is written to these bits.
23 to 0	R127 to R104	All 0	R	Hold the response from the SD card

SD_RSP7 (Mirror of SD_RSP76[31:16])

Bit	Bit Name	Initial Value	R/W	Description
63 to 8	—	All 0	R	Reserved These bits are always read as 0. The write value should always be 0. Operation is not guaranteed if a value other than 0 is written to these bits.
7 to 0	R127 to R120	All 0	R	Hold the response from the SD card

Table 40.3 lists the response types and corresponding SD_RSP registers.

Table 40.3 Response Types and Corresponding SD_RSP Registers

Response Types	SD_RSP Registers
R1, R1b[39:8]	SD_RSP10 SD_RSP54*1
R2[127:8]	SD_RSP54 and SD_RSP10
R3[39:8]	SD_RSP10
R4[39:8]	SD_RSP10
R5[39:8]	SD_RSP10
R6[39:8]	SD_RSP10
R7[39:8]	SD_RSP10

Note 1. The response to CMD18 and to CMD25 is stored in both R[39:8] and R[103:72]. This makes it possible to confirm the response to CMD18 and CMD25 by reading R[103:72] even if the response to automatic CMD12 is stored in R[39:8].

40.2.6 SD Card Interrupt Flag Register (SD_INFO1)

The SD card interrupt flag register 1 (SD_INFO1) indicates the response end and access end in the command sequence. This register also indicates the card detect/write protect state.

For CMD12 and CMD52 (SDIO abort) at multiple block transfer, INFO0 is not set but only INFO2 is set.

Even if the command sequence is halted because of a communications error or timeout, INFO0 or INFO2 is set.

INFO10, INFO9, and INFO8 change depending on the SDDAT3 state after a reset is released and continue to change in 4-bit transfer mode.

To clear a flag, write 0 to the bit to be cleared and 1 to the other bits.

Bit	Bit Name	Initial Value	R/W	Description
63 to 17	—	All 0	R	Reserved These bits are always read as 0. The write value should always be 0. Operation is not guaranteed if a value other than 0 is written to these bits.
16	HPIRES	0*2	R/W*1	Response Reception Completion [Setting condition] When reception of the response to CMD12 that was issued by setting the STP bit to 1 is completed during the CMD6/CMD38 or CMD25 sequence in HPI mode. [Clearing condition] When 0 is written to HPIRES
15 to 11	—	All 0	R	Reserved These bits are always read as 0. The write value should always be 0. Operation is not guaranteed if a value other than 0 is written to these bits.
10	INFO10	Unknown	R	Indicates the SDDAT3 state. 0: SDDAT3 is set to 0. 1: SDDAT3 is set to 1.
9	INFO9	0	R/W*1	SDDAT3 Card Insertion [Setting condition] After change in SDDAT3 from 0 to 1, two cycles of 2 P1φ have elapsed with SDDAT3 held 1. [Clearing condition] When 0 is written to INFO9
8	INFO8	0	R/W*1	SDDAT3 Card Removal [Setting condition] After change in SDDAT3 from 1 to 0, two cycles of 2 P1φ have elapsed with SDDAT3 held 0. [Clearing condition] When 0 is written to INFO8
7	INFO7	Unknown	R	Write Protect Indicates the ISDWP state. 0: ISDWP is set to 1. 1: ISDWP is set to 0.
6	—	0	R	Reserved This bit is always read as 0. The write value should always be 0. Operation is not guaranteed if a value other than 0 is written to this bit.
5	INFO5	Unknown	R	Indicates the ISDCD state. 0: Indicates that Mcycle has elapsed with ISDCD held 1. 1: Indicates that Mcycle has elapsed with ISDCD held 0. Mcycle is set by bits 3 to 0 in SD_OPTION.

Bit	Bit Name	Initial Value	R/W	Description
4	INFO4	0	R/W*1	<p>ISDCD Card Insertion</p> <p>[Setting condition] After change in ISDCD from 1 to 0, Mcycle has elapsed with ISDCD held 0.</p> <p>[Clearing condition] When 0 is written to INFO4 Mcycle is set by bits 3 to 0 in SD_OPTION.</p>
3	INFO3	0	R/W*1	<p>ISDCD Card Removal</p> <p>[Setting condition] After change in ISDCD from 0 to 1, Mcycle has elapsed with ISDCD held 1.</p> <p>[Clearing condition] When 0 is written to INFO3 Mcycle is set by bits 3 to 0 in SD_OPTION.</p>
2	INFO2	0*2	R/W*1	<p>Access End</p> <p>[Setting conditions]</p> <ol style="list-style-type: none"> When read access to the buffer is completed in the case of transfer for single block read When read access to the buffer for the last block of data is completed in the case of transfer for multiple block read When read access to the buffer and reception of the response to CMD12 are completed in the case of transfer for multiple block read with automatic issuing of CMD12 When reception of the busy state after reception of the CRC status is completed in the case of transfer for single block write When reception of the busy state after reception of the CRC status of the last block of data is completed in the case of transfer for multiple block write When reception of the response busy state for CMD12 is completed in the case of transfer for multiple block write with automatic issuing of CMD12 When reception of the response to CMD12 that was issued by setting the STP bit to 1 is completed in the case of transfer for multiple block read When reception of the response busy state for CMD12 that was issued by setting the STP bit to 1 is completed in the case of transfer for multiple block write When reception of the response to CMD52 that was issued by setting the IOABT bit to 1 is completed in the case of transfer for multiple block read When reception of the response to CMD52 that was issued by setting the IOABT bit to 1 is completed in the case of transfer for multiple block write <p>In addition to the above conditions, this bit is set when a command sequence is halted because of a communications error or timeout.</p> <p>[Clearing condition] When 0 is written to INFO2 When the access end bit is set to 1, the command sequence is terminated.</p>
1	—	0	R	<p>Reserved</p> <p>This bit is always read as 0. The write value should always be 0. Operation is not guaranteed if a value other than 0 is written to this bit.</p>

Bit	Bit Name	Initial Value	R/W	Description
0	INFO0	0*2	R/W*1	<p>Response End</p> <p>[Setting conditions]</p> <ol style="list-style-type: none"> 1. When the reception of the response is completed 2. When the transmission of the command not requiring a response is completed, 3. When receiving busy reception after R1b response 4. When reception of the response to CMD52 that was issued by setting the C52PUB bit to 1 is completed in the case of transfer for multiple block read 5. When reception of the response to CMD52 that was issued by setting the C52PUB bit to 1 is completed in the case of transfer for multiple block write, <p>In addition to the above conditions, this bit is set when a command sequence is halted because of a communications error or timeout.</p> <p>[Clearing condition]</p> <p>When 0 is written to INFO0</p> <p>When issuing a command without data, the command sequence ends when the response end is set to 1.</p>

Note 1. It is effective only if 0 is written.

Note 2. The value is initialized by a reset and also in the case of a reset by the SDRST bit in SOFT_RST.

40.2.7 SD Card Interrupt Flag Register (SD_INFO2)

The SD card interrupt flag register 2 (SD_INFO2) indicates the access status of the SD buffer (SD_BUF) and SD card. To clear a flag, write 0 to the bit to be cleared and 1 to the other bits.

Bit	Bit Name	Initial Value	R/W	Description
63 to 16	—	All 0	R	Reserved These bits are always read as 0. The write value should always be 0. Operation is not guaranteed if a value other than 0 is written to these bits.
15	ILA	0*2	R/W*1	Illegal Access Error [Setting conditions] 1. Writing of data to SD_CMD within a command sequence (CBSY=1) 2. When SD_CMD[11] = 1 (command with data transfer) and SD_CMD[7:0] = 0000 1100b (CMD12) are set in SD_CMD [Clearing condition] When 0 is written to ILA
14	CBSY	0*2	R	Command Type Register Busy 0: A command sequence has been completed. 1: A command sequence is being executed.
13	SCLKDIVEN	1*2	R	0: The SD bus (CMD, DAT) is busy. Do not attempt to write to the SD_CLK_CTRL register. 1: The SD bus (CMD, DAT) is not busy. When a command sequence is started by writing to SD_CMD, the CBSY bit is set to 1 and, at the same time, the SCLKDIVEN bit is set to 0. The SCLKDIVEN bit is set to 1 after 8 cycles of SDCLK have elapsed after setting of the CBSY bit to 0 due to completion of the command sequence.
12	—	0	R	Reserved This bit is always read as 0. The write value should always be 0. Operation is not guaranteed if a value other than 0 is written to this bit.
11	—	0	R/W	Reserved The write value should always be 1.
10	—	0	R	Reserved This bit is always read as 0. The write value should always be 0. Operation is not guaranteed if a value other than 0 is written to this bit.
9	BWE	0*2	R/W*1	SD_BUF Write Enable 0: Data cannot be written in SD_BUF0. 1: Data can be written in SD_BUF0. [Setting conditions] 1. When SD_BUF is empty at single block transfer 2. When either bank 1 or bank 2 of SD_BUF is empty at multiple block transfer [Clearing conditions] 1. When 0 is written to BWE 2. Writing of a block of data to SD_BUF by DMA transfer When data is written to SD_BUF0 by the CPU, clear BWE and then write amount of data specified by SD_SIZE*3

Bit	Bit Name	Initial Value	R/W	Description
8	BRE	0*2	R/W*1	<p>SD_BUF Read Enable</p> <p>0: Data cannot be read from SD_BUF0. 1: Data can be read from SD_BUF0.</p> <p>[Setting conditions]</p> <ol style="list-style-type: none"> When data set in SD_SIZE is stored in SD_BUF at single block transfer When data set in SD_SIZE is stored in either bank 1 or bank 2 of SD_BUF at multiple block transfer <p>[Clearing conditions]</p> <ol style="list-style-type: none"> When 0 is written to BRE Reading of a block of data from SD_BUF by DMA transfer <p>When data is read from SD_BUF0 by the CPU, clear BRE and then read amount of data specified by SD_SIZE*3.</p> <p>Even if a CRC error or an END error occurs while block data is read, data is stored in SD_BUF and BRE is set.</p>
7	DAT0	Unknown	R	<p>SDDAT0</p> <p>Indicates the SDDAT0 state.</p> <p>0: SDDAT0 is set to 0. 1: SDDAT0 is set to 1.</p> <p>If the data timeout (ERR3) is set but the response timeout (ERR6) is not set after the Erase command has been issued, the end of the Erase sequence (DAT0 = 1) is confirmed by polling DAT0.</p> <p>If a communications error or timeout occurs during a write sequence, the DAT0 bit may retain the value 0.</p> <p>While the SD clock (SDCLK) is stopped, the DAT0 bit retains the value before the clock is stopped.</p>
6	ERR6	0*2	R/W*1	<p>Response Timeout</p> <p>[Setting condition]</p> <p>When a response is not received even after 640 cycles of SDCLK have elapsed (including a response to a command issued within a command sequence*5)</p> <p>[Clearing condition]</p> <p>When 0 is written to ERR6</p> <p>The command sequence is halted by a response timeout.*4</p>
5	ERR5	0*2	R/W*1	<p>SD_BUF Illegal Read Access</p> <p>[Setting conditions]</p> <ol style="list-style-type: none"> When SD_BUF is empty while SD_BUF0 is read When data with a CRC error or END error is read from SD_BUF0 <p>[Clearing condition]</p> <p>When 0 is written to ERR5</p>
4	ERR4	0*2	R/W*1	<p>SD_BUF Illegal Write Access</p> <p>[Setting conditions]</p> <ol style="list-style-type: none"> When data is written to SD_BUF0 while it is not in the data read/write command state When data is written to SD_BUF0 while SD_BUF is full When data is written to SD_BUF0 while an error occurs in the CRC status or CRC status length When data is written to SD_BUF0 while the interface remains in a busy state for at least Ncycle after the CRC status <p>[Clearing condition]</p> <p>When 0 is written to ERR4</p> <p>Ncycle is set by bits 7 to 4 in SD_OPTION.</p>

Bit	Bit Name	Initial Value	R/W	Description
3	ERR3	0*2	R/W*1	<p>Data Timeout (except response timeout)</p> <p>[Setting conditions]</p> <ol style="list-style-type: none"> 1. After R1b response, the interface remains in a busy state (SDDAT0 = 0) for at least Ncycle. 2. After CRC status, the interface remains in a busy state (SDDAT0 = 0) for at least Ncycle. 3. After write data, the CRC status is not received even after Ncycle has elapsed. 4. After read command, read data is not received even after Ncycle has elapsed. 5. After CMD12 has been issued within a command sequence, the interface remains in a busy state (SDDAT0 = 0) for at least Ncycle. 6. After the reception of read data, read data for the next block are not received even after Ncycle has elapsed. 7. After release of the read wait state, read data for the next block are not received even after Ncycle has elapsed. <p>[Clearing condition]</p> <p>When 0 is written to ERR3</p> <p>Ncycle is set by bits 7 to 4 in SD_OPTION.</p> <p>The command sequence is halted by the data timeout.</p>
2	ERR2	0*2	R/W*1	<p>END Error</p> <p>[Setting conditions]</p> <ol style="list-style-type: none"> 1. When an error occurs in the response length (and the end bit has not been detected) 2. When an error occurs in the read data length (and the end bit has not been detected among the valid bits) 3. When an error occurs in the CRC status length (and the end bit has not been detected) 4. An error in the length of a response to a command issued within a command sequence*5 (i.e. the end bit has not been detected) <p>[Clearing condition]</p> <p>When 0 is written to ERR2</p> <p>The command sequence is halted by the End error.*4</p>
1	ERR1	0*2	R/W*1	<p>CRC Error</p> <p>[Setting conditions]</p> <ol style="list-style-type: none"> 1. When an error occurs in the CRC status (i.e. the received CRC status was not 010') 2. When a CRC error occurs in the read data 3. When a CRC error occurs in the response 4. A CRC error in the response to a command issued within a command sequence*5 <p>[Clearing condition]</p> <p>When 0 is written to ERR1</p> <p>The command sequence is halted by the CRC error.*4</p>
0	ERR0	0*2	R/W*1	<p>CMD Error</p> <p>[Setting conditions]</p> <ol style="list-style-type: none"> 1. The command index of the transmitted command differing from the command index of the received response 2. The command index of a command issued within a command sequence*5 differing from the command index of the received response <p>[Clearing condition]</p> <p>When 0 is written to ERR0</p> <p>The command sequence is halted by the CMD error.*4</p>

Note 1. It is effective only if 0 is written.

Note 2. The initial value is applied at a reset and when the SDRST bit in SOFT_RST is 0.

Note 3. When the WMODE bit in HOST_MODE is 0, the single byte from the fraction of a full 16-bit unit is regarded as excess data due to an odd value for the number of bytes setting in SD_SIZE. When the WMODE bit in HOST_MODE is 1, the single byte or three bytes from the fraction of a full 64-bit unit are regarded as excess data due to an odd value for the number of bytes

setting in SD_SIZE, or the two bytes from the fraction of a full 64-bit unit are regarded as excess data due if the value for the number of bytes setting in SD_SIZE is even but is not on a four-byte boundary.

- Note 4. After the C52PUB bit in SDIO_MODE has been set to 1, if a communications error or timeout for response occurs in response to the CMD52 that is issued, since the command sequence has not been completed, complete the sequence with error processing as in usage examples in **Figure 40.16** under **Section 40.4.8, IO_RW_EXTENDED (CMD53/Multiple Block Read)** or in **Figure 40.19** under **Section 40.4.9, IO_RW_EXTENDED (CMD53/Multiple Block Write)**.
- Note 5. "Command issued within a command sequence" refers to CMD12 when automatic issuing is enabled for multiple block transfer by the setting in SD_CMD, CMD12 when the STP bit in SD_STOP is set to 1, or CMD52 when the C52PUB or IOABT bit in SDIO_MODE is set to 1.

40.2.8 SD_INFO1 Interrupt Mask Register (SD_INFO1_MASK)

The SD_INFO1 interrupt mask register (SD_INFO1_MASK) is used to enable or disable the SD_INFO1 interrupt.

When 0 is set in SD_INFO1_MASK while the corresponding flag in SD_INFO1 is set, an interrupt occurs.

Bit	Bit Name	Initial Value	R/W	Description
63 to 17	—	All 0	R	Reserved These bits are always read as 0. The write value should always be 0. Operation is not guaranteed if a value other than 0 is written to these bits.
16	IMASK16	1	R/W	HPIRES interrupt masked
15 to 10	—	All 0	R	Reserved These bits are always read as 0. The write value should always be 0. Operation is not guaranteed if a value other than 0 is written to these bits.
9	IMASK9	1	R/W	INFO9 interrupt masked
8	IMASK8	1	R/W	INFO8 interrupt masked
7 to 5	—	All 0	R	Reserved These bits are always read as 0. The write value should always be 0. Operation is not guaranteed if a value other than 0 is written to these bits.
4	IMASK4	1	R/W	INFO4 interrupt masked
3	IMASK3	1	R/W	INFO3 interrupt masked
2	IMASK2	1	R/W	INFO2 interrupt masked
1	—	0	R	Reserved This bit is always read as 0. The write value should always be 0. Operation is not guaranteed if a value other than 0 is written to this bit.
0	IMASK0	1	R/W	INFO0 interrupt masked

40.2.9 SD_INFO2 Interrupt Mask Register (SD_INFO2_MASK)

The SD_INFO2 interrupt mask register (SD_INFO2_MASK) is used to enable or disable the SD_INFO2 interrupt.

When 0 is set in SD_INFO2_MASK while the corresponding flag in SD_INFO2 is set, an interrupt occurs.

Bit	Bit Name	Initial Value	R/W	Description
63 to 16	—	All 0	R	Reserved These bits are always read as 0. The write value should always be 0. Operation is not guaranteed if a value other than 0 is written to these bits.
15	IMASK	1	R/W	ILA interrupt masked
14 to 12	—	All 0	R	Reserved These bits are always read as 0. The write value should always be 0. Operation is not guaranteed if a value other than 0 is written to these bits.
11	—	1	R/W	Reserved The write value should always be 1.
10	—	0	R	Reserved This bit is always read as 0. The write value should always be 0. Operation is not guaranteed if a value other than 0 is written to this bit.
9	BMASK1	1	R/W	BWE interrupt masked
8	BMASK0	1	R/W	BRE interrupt masked
7	—	0	R	Reserved This bit is always read as 0. The write value should always be 0. Operation is not guaranteed if a value other than 0 is written to this bit.
6	EMASK6	1	R/W	ERR6 interrupt masked
5	EMASK5	1	R/W	ERR5 interrupt masked
4	EMASK4	1	R/W	ERR4 interrupt masked
3	EMASK3	1	R/W	ERR3 interrupt masked
2	EMASK2	1	R/W	ERR2 interrupt masked
1	EMASK1	1	R/W	ERR1 interrupt masked
0	EMASK0	1	R/W	ERR0 interrupt masked

40.2.10 SD Clock Control Register (SD_CLK_CTRL)

The SD clock control register (SD_CLK_CTRL) is used to control the SD clock (SDCLK) output and to set the frequency. Set SCLKEN to 1 before writing to SD_CMD to issue a command. Do not write to SD_CLK_CTRL while the SCLKDIVEN bit in SD_INFO2 is set to 0.

Bit	Bit Name	Initial Value	R/W	Description
63 to 17	—	All 0	R	Reserved These bits are always read as 0. The write value should always be 0. Operation is not guaranteed if a value other than 0 is written to these bits.
16	—	0	R/W	Reserved The write value should always be 0.
15 to 11	—	All 0	R	Reserved These bits are always read as 0. The write value should always be 0. Operation is not guaranteed if a value other than 0 is written to these bits.
10	—	0*1	R/W	Reserved The write value should always be 0.
9	SDCLKOFFEN	0	R/W	SD Clock (SDCLK) Output Automatic Control Enable 0: Automatic control for SD clock (SDCLK) output is disabled. 1: Automatic control for SD clock (SDCLK) output is enabled. This function of automatic control for SD clock (SDCLK) output causes SDCLK output only within a command sequence. The timing with which SDCLK output starts and stops is as follows. SDCLK output starts after writing to SD_CMD. SDCLK output stops when 8 cycles of SDCLK have elapsed after the end of the command sequence. In addition, SDCLK is fixed to 0 while SCLKEN of SD_CLK_CTRL is 0, regardless of the value of this bit.
8	SCLKEN	0*1	R/W*2	SD Clock (SDCLK) Output Control Enable 0: SD clock (SDCLK) output is disabled. The SDCLK signal is fixed 0. 1: SD clock (SDCLK) output is enabled.
7	DIV7	0	R/W*2	SD Clock (SDCLK) 1000 0000b: (SDxφ/4)/512 0100 0000b: (SDxφ/4)/256 0010 0000b: (SDxφ/4)/128 0001 0000b: (SDxφ/4)/64 0000 1000b: (SDxφ/4)/32 0000 0100b: (SDxφ/4)/16 0000 0010b: (SDxφ/4)/8 0000 0001b: (SDxφ/4)/4 0000 0000b: (SDxφ/4)/2 1111 1111b: SDxφ/4 (x = 0, 1) Other settings are prohibited.
6	DIV6	0	R/W*2	
5	DIV5	1	R/W*2	
4	DIV4	0	R/W*2	
3	DIV3	0	R/W*2	
2	DIV2	0	R/W*2	
1	DIV1	0	R/W*2	
0	DIV0	0	R/W*2	

Note 1. This initial value is applied at a reset and when the SDRST bit in SOFT_RST is 0.

Note 2. Writing to SD_CLK_CTRL is impossible when the CBSY bit in SD_INFO2 is 1.

Notes on when setting the SD clock (SDCLK) to P1 ϕ (DIV[7:0] = 1111 1111b)

When changing the setting of bits DIV[7:0] to 1111 1111b, or from 1111 1111b to other setting, perform the following processing before writing to SD_CMD.

- (1) Set the SCLKEN bit to 0 by writing to SD_CLK_CTRL. (Do not change the setting of bits other than SCLKEN at this time.)
- (2) Change the setting of bits DIV[7:0] by writing to SD_CLK_CTRL. (Do not change the setting of bits other than DIV[7:0] at this time. The SCLKEN bit should retain the value 0.)
- (3) Set the SCLKEN bit to 1 by writing to SD_CLK_CTRL. (Do not change the setting of bits other than SCLKEN at this time.)

Also when changing the setting of bits DIV[7:0] to 1111 1111b after having set the SDRST bit in SOFT_RST to 0 and then changed it to 1, perform this processing before writing to SD_CMD.

40.2.11 Transfer Data Length Register (SD_SIZE)

The transfer data length register (SD_SIZE) is used to specify the transfer data size.

Bit	Bit Name	Initial Value	R/W	Description
63 to 12	—	All 0	R	Reserved These bits are always read as 0. The write value should always be 0. Operation is not guaranteed if a value other than 0 is written to these bits.
11, 10	—	All 0	R	Reserved
9 to 0	LEN9 to LEN0	10000000 00	R/W	Transfer Data Size* ¹ These bits specify a size between 1 and 512 bytes for single block transfer. In cases of multiple block transfer with automatic issuing of CMD12 (CMD18 and CMD25), the only specifiable transfer data size is 512 bytes. Furthermore, in cases of multiple block transfer without automatic issuing of CMD12, as well as 512 bytes, 32, 64, 128, and 256 bytes are specifiable. However, in the reading of 32, 64, 128, and 256 bytes for the transfer of multiple blocks, this is restricted to multiple block transfer by CMD53. Additionally, if a command accompanies data transfer, do not set these bits to 0. Do not specify a data size larger than 512 bytes.

Note 1. Do not change the values of these bits when the CBSY bit in SD_INFO2 is 1.

40.2.12 SD Card Access Control Option Register (SD_OPTION)

The SD card access control option register (SD_OPTION) is used to set the bus width and timeout counter.

Bit	Bit Name	Initial Value	R/W	Description
63 to 16	—	All 0	R	Reserved These bits are always read as 0. The write value should always be 0. Operation is not guaranteed if a value other than 0 is written to these bits.
15	WIDTH	0*1	R/W	Bus width*2 {WIDTH,WIDTH8} = 01: 8 bits width {WIDTH,WIDTH8} = 00: 4 bits width {WIDTH,WIDTH8} = 10,11: 1 bit width In the case of writing of one-byte block, 8 bits width cannot be specified for the bus width. Change the bus width to 4 bits or 1 bit before writing one-byte block.
14	—	1	R	Reserved This bit is always read as 1. The write value should always be 1. Operation is not guaranteed if a value other than 1 is written to this bit.
13	WIDTH8	0*1	R/W	Bus width*2 See the description of the WIDTH bit.
12 to 10	—	All 0	R	Reserved These bits are always read as 0. The write value should always be 0. Operation is not guaranteed if a value other than 0 is written to these bits.
9	EXTOP	0*1	R/W	Timeout Mode Select 0: Bits TOP27 to TOP24 specify the timeout count from SDCLK*2 ¹³ to SDCLK*2 ²⁷ . 1: Bits TOP27 to TOP24 specify the timeout count from SDCLK*2 ¹⁴ to SDCLK*2 ²⁸ .
8	TOUTMASK	0*1	R/W	Timeout Mask 0: Enables timeout. 1: Disables timeout. (The ERR6 and ERR3 bits in SD_INFO2 and the E6 to E0 bits in SD_ERR_STS2 are not set.) If a timeout occurs while it is disabled, perform a software reset to terminate a command sequence.
7	TOP27	1*1	R/W	Timeout Counter*2
6	TOP26	1*1	R/W	0000: SDCLK*2 ¹³
5	TOP25	1*1	R/W	0001: SDCLK*2 ¹⁴
4	TOP24	0*1	R/W	: 1101: SDCLK*2 ²⁶ 1110: SDCLK*2 ²⁷ 1111: Setting prohibited
3	CTOP24	1*1	R/W	Card Detect Time Counter
2	CTOP23	1*1	R/W	0000: SDCLK*2 ¹⁰
1	CTOP22	1*1	R/W	0001: SDCLK*2 ¹¹
0	CTOP21	0*1	R/W	: 1101: SDCLK*2 ²³ 1110: SDCLK*2 ²⁴ 1111: Setting prohibited

Note 1. The initial value is applied at a reset and when the SDRST bit in SOFT_RST is 0.

Note 2. Do not change the values of these bits when the CBSY bit in SD_INFO2 is 1.

40.2.13 SD Error Status Register 1 (SD_ERR_STS1)

The SD error status register 1 (SD_ERR_STS1) indicates the CRC status, CRC error, End error, and CMD error.

Bit	Bit Name	Initial Value	R/W	Description
63 to 32	—	All 0	R	Reserved These bits are always read as 0. The write value should always be 0. Operation is not guaranteed if a value other than 0 is written to these bits.
31 to 15	—	Unknown	R	Reserved These bits are always read as unknown. The write value should always be 0.
14	E14	0*1	R	These bits hold the CRC status. (normal: 010)
13	E13	1*1		
12	E12	0*1		
11	E11	0*1	R	Set to 1 when an error occurs in the CRC status.
10	E10	0*1	R	Set to 1 when a CRC error occurs in the read data.
9	E9	0*1	R	Set to 1 when a CRC error occurs in the response to a command issued within a command sequence*2. In cases where CMD12 is issued by setting a command index in SD_CMD, this is indicated in E8.
8	E8	0*1	R	Set to 1 when a CRC error occurs in a response (other than a response to a command issued within a command sequence*2).
7, 6	—	All 0	R	Reserved These bits are always read as 0. The write value should always be 0. Operation is not guaranteed if a value other than 0 is written to these bits.
5	E5	0*1	R	Set to 1 when an error occurs in the CRC status length (and the end bit has not been detected).
4	E4	0*1	R	Set to 1 when an error occurs in the read data length (and the end bit has not been detected among the valid bits).
3	E3	0*1	R	Set to 1 when an error occurs in the response length to a command issued within a command sequence*2. In cases where CMD12 is issued by setting a command index in SD_CMD, this is indicated in E2.
2	E2	0*1	R	Set to 1 when an error occurs in the response length (other than a response to a command issued within a command sequence*2).
1	E1	0*1	R	Set to 1 when an error occurs in the command index of the response to a command issued within a command sequence*2. In cases where CMD12 is issued by setting a command index in SD_CMD, this is Indicated in E0.
0	E0	0*1	R	Set to 1 when an error occurs in the command index of a response (other than a response to a command issued within a command sequence*2).

Note 1. The initial value is applied at a reset and when the SDRST bit in SOFT_RST is 0.

Note 2. "Command issued within a command sequence" refers to CMD12 when automatic issuing is enabled for multiple block transfer by the setting in SD_CMD, CMD12 when the STP bit in SD_STOP is set to 1, or CMD52 when the C52PUB or IOABT bit in SDIO_MODE is set to 1.

40.2.14 SD Error Status Register 2 (SD_ERR_STS2)

The SD error status register 2 (SD_ERR_STS2) indicates the timeout state. Ncycle is set by bits 7 to 4 in SD_OPTION.

Bit	Bit Name	Initial Value	R/W	Description
63 to 7	—	All 0	R	Reserved These bits are always read as 0. The write value should always be 0. Operation is not guaranteed if a value other than 0 is written to these bits.
6	E6	0*1	R	Set to 1 when the interface remains in a busy state for at least Ncycle after the CRC status.
5	E5	0*1	R	Set to 1 when the CRC status is not received even after Ncycle has elapsed after data writing.
4	E4	0*1	R	Set to 1 when read data is not received even after Ncycle has elapsed after the command has been read. Set to 1 when read data for the next block are not received even after Ncycle has elapsed after the reception of read data. Set to 1 when read data for the next block are not received even after Ncycle has elapsed after release of the read wait state.
3	E3	0*1	R	Set to 1 when the interface remains in a busy state for at least Ncycle after CMD12 has been issued within a command sequence. In cases where CMD12 is issued by setting a command index in SD_CMD, this is indicated in E2.
2	E2	0*1	R	Set to 1 when the interface remains in a busy state for at least Ncycle after R1b response.
1	E1	0*1	R	Set to 1 when the response to a command issued within a command sequence*2 is not received even after 640 cycles of SDCLK have elapsed. In cases where CMD12 is issued by setting a command index in SD_CMD, this is indicated in E0.
0	E0	0*1	R	Set to 1 when the response (other than a response to a command issued within a command sequence*2) is not received even after 640 cycles of SDCLK have elapsed.

Note 1. The initial value is applied at a reset and when the SDRST bit in SOFT_RST is 0.

Note 2. "Command issued within a command sequence" refers to CMD12 when automatic issuing is enabled for multiple block transfer by the setting in SD_CMD, CMD12 when the STP bit in SD_STOP is set to 1, or CMD52 when the C52PUB or IOABT bit in SDIO_MODE is set to 1.

40.2.15 SD Buffer Read/Write Register (SD_BUF0)

Bit	Bit Name	Initial Value	R/W	Description
63 to 0	BUF63 to BUF0	Unknown	R/W	When writing to the SD card, the write data is written to this register. When reading from the SD card, the read data is read from this register. This register is internally connected to two 512-byte buffers (SD_BUF). When both buffers are not empty at multiple block read, suspend data reception by stopping the SD clock. When either buffer becomes empty, restart data reception by starting supply of the SD clock.

Note: When using the DMAC, the bus width should be fixed at 64 bits.

40.2.16 SDIO Mode Control Register (SDIO_MODE)

The SDIO mode control register (SDIO_MODE) controls the CMD52 issuance and the read wait state at multiple block transfer, and the reception of SDIO interrupt. C52PUB and IOABT should not be set to 1 simultaneously.

Bit	Bit Name	Initial Value	R/W	Description
63 to 10	—	All 0	R	Reserved These bits are always read as 0. The write value should always be 0. Operation is not guaranteed if a value other than 0 is written to these bits.
9	C52PUB	0	R/W	SDIO None Abort <ul style="list-style-type: none"> When C52PUB is set to 1 in the CMD53 (multiple block) write sequence, CMD52 is automatically issued between blocks if SD_BUF becomes empty. C52PUB is automatically cleared to 0 after reception of the response to CMD52 is completed. Additionally, if C52PUB is set to 1 while the last block is being transferred, CMD52 is not issued. In this case, C52PUB is automatically cleared to 0 after the access end flag has been set to 1. When C52PUB and RWREQ are set to 1 in the CMD53 (multiple block) read sequence, the block transfer enters the read wait state between blocks and CMD52 is automatically issued. C52PUB is automatically cleared to 0 after reception of the response to CMD52 is completed. Additionally, if C52PUB is set to 1 while the last block is being transferred, CMD52 is not issued. In this case, C52PUB is automatically cleared to 0 after the access end flag has been set to 1. If C52PUB is set to 1 in the CMD53 (multiple block) read sequence, be sure to set RWREQ to 1 as well as C52PUB. Set SD_ARG before setting C52PUB to 1. Set C52PUB to 1 after the response end flag has been set.
8	IOABT	0	R/W	SDIO Abort <ul style="list-style-type: none"> When IOABT is set to 1 in the CMD53 (multiple block) sequence, the CMD53 sequence is halted and CMD52 is issued. However, if a command sequence is halted because of a communications error or timeout, CMD52 is not issued. Although continued buffer access is possible even after IOABT has been set to 1, the buffer access error bit (ERR5 or ERR4) in SD_INFO2 will be set accordingly. Set SD_ARG before setting IOABT to 1. When IOABT has been set to 1 during transfer for single block write, the access end flag is set when SD_BUF becomes empty, and CMD52 is not issued. If SD_BUF does contain data, the access end flag is set on completion of reception of the busy state without CMD52 having been issued. When IOABT has been set to 1 during transfer for single block read, the access end flag is set immediately after setting of IOABT and CMD52 is not issued. When IOABT is set to 1 during reception of the busy state after an R1b response, the access end flag is set on completion of reception of the busy state without CMD52 having been issued. When IOABT is set to 1 after a command sequence has been completed, CMD52 is not issued and the access end flag is not set. Set IOABT to 1 after the response end flag has been set. Set IOABT to 0 after the access end flag has been set.
7 to 3	—	All 0	R	Reserved These bits are always read as 0. The write value should always be 0. Operation is not guaranteed if a value other than 0 is written to these bits.

Bit	Bit Name	Initial Value	R/W	Description
2	RWREQ	0	R/W	<p>Read Wait Request</p> <p>When RWREQ is set to 1 in the CMD53 (multiple block) read sequence, the block transfer enters the read wait state between blocks.</p> <p>[Read wait state releasing]</p> <p>(1) The read wait state is released, when RWREQ is cleared to 0 in the read wait state.</p> <p>(2) When IOABT is set to 1 in the read wait state, RWREQ is automatically cleared to 0 after CMD52 has been issued, and then the read wait state is released.</p> <p>(3) When C52PUB and RWREQ are set to 1 simultaneously in the CMD53 (multiple block) read sequence, the read wait state is not automatically released. Therefore, after the CMD52 response is received, clear RWREQ. (Be sure to set RWREQ and C52PUB simultaneously.)</p> <p>When RWREQ is set to 1 while the last block in the CMD53 (multiple block) read sequence is transferred, the read wait state is not entered and RWREQ is automatically cleared to 0 by setting access end.</p> <p>Set RWREQ to 1 after the response end flag has been set.</p>
1	—	0	R	<p>Reserved</p> <p>This bit is always read as 0. The write value should always be 0. Operation is not guaranteed if a value other than 0 is written to this bit.</p>
0	IOMOD	0	R/W	<p>SDIO Mode*1</p> <p>0: Disables the SD/MMC host interfaces to receive SDIO interrupt from the SDIO card</p> <p>1: Enables the SD/MMC host interfaces to receive SDIO interrupt from the SDIO card</p>

Note 1. Do not change the value of this bit when the CBSY bit in SD_INFO2 is set to 1.

40.2.17 SDIO Interrupt Flag Register (SDIO_INFO1)

The SDIO interrupt flag register (SDIO_INFO1) indicates the status regarding to the SDIO card access. To clear a flag, write 0 to the bit to be cleared and 1 to the other bits.

Bit	Bit Name	Initial Value	R/W	Description
63 to 16	—	All 0	R	Reserved These bits are always read as 0. The write value should always be 0. Operation is not guaranteed if a value other than 0 is written to these bits.
15	EXWT	0* ²	R/W* ¹	[Setting condition] While the last block in the CMD53 (multiple block) read sequence is transferred, RWREQ in SDIO_MODE is set to 1. [Clearing condition] When 0 is written to EXWT
14	EXPUB52	0* ²	R/W* ¹	[Setting conditions] 1. While the last block in the CMD53 (multiple block) sequence is transferred, C52PUB in SDIO_MODE is set to 1. 2. While C52PUB is set to 1 in the CMD53 (multiple block) write sequence, the last block is transferred. [Clearing condition] When 0 is written to EXPUB52
13 to 3	—	All 0	R	Reserved These bits are always read as 0. The write value should always be 0. Operation is not guaranteed if a value other than 0 is written to these bits.
2, 1	—	All 0* ²	R/W	Reserved The write value should always be 1. The value may change during operation.
0	IOIRQ	0* ²	R/W* ¹	[Setting condition] When SDIO interrupt from an SDIO card is received while IOMOD in SDIO_MODE is set to 1. [Clearing condition] When 0 is written to IOIRQ* ³

Note 1. It is effective only if 0 is written.

Note 2. The initial value is applied at a reset and when the SDRST bit in SOFT_RST is 0.

Note 3. Before clearing this bit, access the SDIO card to negate the SDIO interrupt signal from the SDIO card. If the interrupt signal is not negated, this bit may be set again.

40.2.18 SDIO_INFO1 Interrupt Mask Register (SDIO_INFO1_MASK)

The SDIO_INFO1 interrupt mask register (SDIO_INFO1_MASK) enables or disables the SD_INFO1 interrupt. When 0 is set in SDIO_INFO1_MASK while the corresponding flag in SD_INFO1 is set, an interrupt occurs.

Bit	Bit Name	Initial Value	R/W	Description
63 to 16	—	All 0	R	Reserved These bits are always read as 0. The write value should always be 0. Operation is not guaranteed if a value other than 0 is written to these bits.
15	MEXWT	1	R/W	EXWT interrupt masked
14	MEXPUB52	1	R/W	EXPUB52 interrupt masked
13 to 3	—	All 0	R	Reserved These bits are always read as 0. The write value should always be 0. Operation is not guaranteed if a value other than 0 is written to these bits.
2	—	1	R/W	Reserved The write value should always be 1.
1	—	1	R/W	Reserved The write value should always be 1.
0	IOMSK	1	R/W	IOIRQ interrupt masked

40.2.19 DMA Mode Enable Register (CC_EXT_MODE)

The DMA mode enable register (CC_EXT_MODE) enables the DMA transfer.

Bit	Bit Name	Initial Value	R/W	Description
63 to 13	—	All 0	R	Reserved These bits are always read as 0. The write value should always be 0. Operation is not guaranteed if a value other than 0 is written to these bits.
12	—	1	R	Reserved This bit is always read as 1. The write value should always be 1. Operation is not guaranteed if a value other than 1 is written to this bit.
11, 10	—	All 0	R	Reserved These bits are always read as 0. The write value should always be 0. Operation is not guaranteed if a value other than 0 is written to these bits.
9, 8	—	All 0	R/W	Reserved The write value should always be 0.
7, 6	—	All 0	R	Reserved These bits are always read as 0. The write value should always be 0. Operation is not guaranteed if a value other than 0 is written to these bits.
5	—	0	R/W	Reserved The write value should always be 0.
4	—	1	R	Reserved This bit is always read as 1. The write value should always be 1. Operation is not guaranteed if a value other than 1 is written to this bit.
3, 2	—	All 0	R	Reserved These bits are always read as 0. The write value should always be 0. Operation is not guaranteed if a value other than 0 is written to these bits.
1	DMASDRW	0	R/W	SD_BUF Read/Write DMA Transfer* ¹ 0: The SD_BUF read/write DMA transfer is disabled. 1: The SD_BUF read/write DMA transfer is enabled.
0	—	0	R/W	Reserved The write value should always be 0.

Note 1. Do not change the value of this bit when the CBSY bit in SD_INFO2 is set to 1.

40.2.20 Software Reset Register (SOFT_RST)

The software reset register (SOFT_RST) sets a software reset. Also use this register to check that release from the reset state has been completed before attempting to use the SD/MMC host interfaces and before attempting access to the other registers.

Bit	Bit Name	Initial Value	R/W	Description
63 to 3	—	All 0	R	Reserved These bits are always read as 0. The write value should always be 0. Operation is not guaranteed if a value other than 0 is written to these bits.
2, 1	—	11	R	Reserved These bits are always read as 1. The write value should always be 1. Operation is not guaranteed if a value other than 1 is written to these bits.
0	SDRST	1	R/W	Software Reset of SD Interface Unit 0: Reset 1: Reset released

40.2.21 Version Register (VERSION)

The version register (VERSION) indicates the version of the SD/MMC host interfaces.

Bit	Bit Name	Initial Value	R/W	Description
63 to 16	—	All 0	R	Reserved These bits are always read as 0. The write value should always be 0. Operation is not guaranteed if a value other than 0 is written to these bits.
15, 14	UR7, UR6	11	R	Reserved These bits are always read as 1. The write value should always be 1. Operation is not guaranteed if a value other than 1 is written to these bits.
13, 12	UR5, UR4	00	R	Reserved These bits are always read as 0. The write value should always be 0. Operation is not guaranteed if a value other than 0 is written to these bits.
11 to 8	UR3 to UR0	H'C	R	Version of Renesas' IP
7 to 0	IP7 to IP0	H'10	R	Version of introductory IP

40.2.22 Host Interface Mode Setting Register (HOST_MODE)

The host interface mode setting register (HOST_MODE) selects the width for access to the data bus.

Bit	Bit Name	Initial Value	R/W	Description
63 to 9	—	All 0	R	Reserved These bits are always read as 0. The write value should always be 0. Operation is not guaranteed if a value other than 0 is written to these bits.
8	BUSWIDTH	0	R/W	Width for Access to SD_BUF ^{*1*2} Read or write access to SD_BUF0 can be performed with the specified width for access. 0: 16-bit access 1: 32-bit access This bit is enabled while the WMODE bit is set to 1.
7 to 2	—	All 0	R	Reserved These bits are always read as 0. The write value should always be 0. Operation is not guaranteed if a value other than 0 is written to these bits.
1	ENDIAN	0	R/W	SD_BUF0 data swap
0	WMODE	0	R/W	Width for Access to SD_BUF ^{*1*2} Read or write access to SD_BUF0 can be performed with the specified width for access. 0: 64-bit access 1: 16-bit or 32-bit access

Note 1. Do not change the value of this bit when the CBSY bit in SD_INFO2 is set to 1.

Note 2. When using the built-in DMAC of this module, fix the bus width to 64 bits.

40.2.23 SD Interface Mode Setting Register (SDIF_MODE)

The SD interface mode setting register specifies transfer mode.

Bit	Bit Name	Initial Value	R/W	Description
63 to 10	—	All 0	R	Reserved These bits are always read as 0. The write value should always be 0. Operation is not guaranteed if a value other than 0 is written to these bits.
9	—	0*1	R/W	Reserved The write value should always be 0.
8	NOCHKCR	0*1	R/W	CRC Check Mask (test command for MMC supported) Enables or disables checking of the CRC16 and CRC status. 0: Enables the CRC check. 1: Disables the CRC check (the CRC16 value is ignored at read, and the CRC status is not detected at write)
7 to 0	—	All 0	R	Reserved These bits are always read as 0. The write value should always be 0. Operation is not guaranteed if a value other than 0 is written to these bits.

Note 1. The initial value is applied at a reset and when the SDRST bit in SOFT_RST is 0.

40.2.24 SD Status Register (SD_STATUS)

The effective bit of the SD status register controls the output value on the SD0_RST# pin.

Bit	Bit Name	Initial Value	R/W	Description
63 to 2	—	All 0	R	Reserved These bits are always read as 0. The write value should always be 0. Operation is not guaranteed if a value other than 0 is written to these bits.
1	SD_RST	0	R/W	Controls the output value on the SD0_RST# pin. 0: The output value on the SD0_RST# pin is 0. 1: The output value on the SD0_RST# pin is 1.
0	—	0	R	Reserved This bit is always read as 0. The write value should always be 0. Operation is not guaranteed if a value other than 0 is written to this bit.

40.2.25 DMAC Transfer Mode Register (DM_CM_DTRAN_MODE)

The DMAC Transfer Mode Register (DM_CM_DTRAN_MODE) sets the operation mode of the module built-in DMAC.

High 32 bits (bit 63 to 32) are read only 0.

Bit	Bit Name	Initial Value	R/W	Description
63 to 18	—	All 0	R	Reserved These bits are always read as 0. The write value should always be 0. Operation is not guaranteed if a value other than 0 is written to these bits.
17, 16	CH_NUM	00	R/W	DMAC channel selector 00 : SD down stream 01 : SD up stream Other settings are prohibited.
15 to 6	—	All 0	R	Reserved These bits are always read as 0. The write value should always be 0. Operation is not guaranteed if a value other than 0 is written to these bits.
5, 4	BUS_WIDTH [1:0]	11	R/W	Bus width selector 11: 64-bit Other settings are prohibited.
3 to 0	—	All 0	R	Reserved These bits are always read as 0. The write value should always be 0. Operation is not guaranteed if a value other than 0 is written to these bits.

40.2.26 DMAC Transfer Control Register (DM_CM_DTRAN_CTRL)

The DMAC Transfer Control Register (DM_CM_DTRAN_CTRL) controls the module built-in DMAC operation. High 32 bits (bit 63-32) are read only 0.

Bit	Bit Name	Initial Value	R/W	Description
63 to 9	—	All 0	R	Reserved These bits are always read as 0. The write value should always be 0. Operation is not guaranteed if a value other than 0 is written to these bits.
8	—	0	R/W	Reserved The write value should always be 0.
7 to 1	—	All 0	R	Reserved
0	DM_START	0	R/W	DMAC Start Writing 1 to this bit starts DMAC operation. This bit is automatically cleared when DMA transfer is started.

40.2.27 DMAC Reset Register (DM_CM_RST)

High 32 bits (bit 63 to 32) are read only 0.

Bit	Bit Name	Initial Value	R/W	Description
63 to 32	—	All 0	R	Reserved These bits are always read as 0. The write value should always be 0. Operation is not guaranteed if a value other than 0 is written to these bits.
31 to 10	—	All 1	R	Reserved These bits are always read as 1. The write value should always be 1.
9	DTRANRST1	1	R/W	Soft resets of the module built-in DMAC channel 1 0: Reset 1: Reset released
8	DTRANRST0	1	R/W	Soft resets of the module built-in DMAC channel 0 0: Reset 1: Reset released
7 to 1	—	All 1	R	Reserved These bits are always read as 1. The write value should always be 1.
0	SEQRST	1	R/W	Soft resets of the sequencer 0: Reset 1: Reset released

NOTE

Make sure there is no communication to the SD/MMC device before applying a software reset using this register.

40.2.28 DMAC Interrupt Register 1 (DM_CM_INFO1)

The DMAC interrupt register 1 (DM_CM_INFO1) indicates the status of the module built-in DMAC and a sequencer. To clear a flag, write 0 to the bit to be cleared and 1 to the other bits.

Bit	Bit Name	Initial Value	R/W	Description
63 to 21	—	All 0	R	Reserved These bits are always read as 0. The write value should always be 0. Operation is not guaranteed if a value other than 0 is written to these bits.
20	DTRANEND1	0*1	R/W	Module built-in DMAC Channel 1 Transfer End [Setting conditions] 1. When transfer of DMAC channel 1 is completed 2. When an error occurs on DMAC channel 1 [Clearing condition] When 0 is written to DTRANEND1
19 to 17	—	All 0	R	Reserved These bits are always read as 0. The write value should always be 0. Operation is not guaranteed if a value other than 0 is written to these bits.
16	DTRANEND0	0*2	R/W	Module built-in DMAC Channel 0 Transfer End [Setting conditions] 1. When transfer of DMAC channel 0 is completed 2. When an error occurs on DMAC channel 0 [Clearing condition] When 0 is written to DTRANEND0
15 to 1	—	All 0	R	Reserved These bits are always read as 0. The write value should always be 0. Operation is not guaranteed if a value other than 0 is written to these bits.
0	SEQEND	0*3	R/W	Sequencer Operation End [Setting conditions] 1. When operation of a sequencer is completed 2. When a sequencer error occurs [Clearing condition] When 0 is written to SEQEND

Note 1. The initial value is applied at a reset and when the DTRANRST1 bit in DM_CM_RST is 0.

Note 2. The initial value is applied at a reset and when the DTRANRST0 bit in DM_CM_RST is 0.

Note 3. The initial value is applied at a reset and when the SEQRST bit in DM_CM_RST is 0.

40.2.29 DM_CM_INFO1 Interrupt Mask Register (DM_CM_INFO1_MASK)

The DM_CM_INFO1 interrupt mask register (DM_CM_INFO1_MASK) enables or disables the DM_CM_INFO1 interrupt. When 0 is set in DM_CM_INFO1_MASK while the corresponding flag in DM_CM_INFO1 is set, an interrupt occurs.

Bit	Bit Name	Initial Value	R/W	Description
63 to 32	—	All 0	R	Reserved These bits are always read as 0. The write value should always be 0. Operation is not guaranteed if a value other than 0 is written to these bits.
31 to 21	—	All 1	R	Reserved These bits are always read as 1. The write value should always be 1. Operation is not guaranteed if a value other than 1 is written to these bits.
20	DTRANEND1_MASK	1	R/W	DTRANEND1 interrupt masked
19 to 17	—	All 1	R/W	Reserved The write value should always be 1.
16	DTRANEND0_MASK	1	R/W	DTRANEND0 interrupt masked
15 to 1	—	All 1	R	Reserved These bits are always read as 1. The write value should always be 1. Operation is not guaranteed if a value other than 1 is written to these bits.
0	SEQEND_MASK	1	R/W	SEQEND interrupt masked

40.2.30 DMAC Interrupt Register 2 (DM_CM_INFO2)

The DMAC interrupt register 2 (DM_CM_INFO2) indicates the status of the module built-in DMAC and a sequencer. To clear a flag, write 0 to the bit to be cleared and 1 to the other bits.

Bit	Bit Name	Initial Value	R/W	Description
63 to 20	—	All 0	R	Reserved These bits are always read as 0. The write value should always be 0. Operation is not guaranteed if a value other than 0 is written to these bits.
19, 18	—	00	R	Reserved The write value should always be 0.
17	DTRANERR1	0* ¹	R/W	Module built-in DMAC Channel 1 Error [Setting condition] When an error occurs on DMAC channel 1 [Clearing condition] When 0 is written to DTRANERR1
16	DTRANERR0	0* ²	R/W	Module built-in DMAC Channel 0 Error [Setting condition] When an error occurs on the DMAC channel 0 [Clearing condition] When 0 is written to DTRANERR0
15 to 1	—	All 0	R	Reserved These bits are always read as 0. The write value should always be 0. Operation is not guaranteed if a value other than 0 is written to these bits.
0	SEQERR	0* ³	R/W	Sequencer error [Setting condition] When a sequencer error occurs [Clearing condition] When 0 is written to SEQERR

Note 1. The initial value is applied at a reset and when the DTRANRST1 bit in DM_CM_RST is 0.

Note 2. The initial value is applied at a reset and when the DTRANRST0 bit in DM_CM_RST is 0.

Note 3. The initial value is applied at a reset and when the SEQRST bit in DM_CM_RST is 0.

40.2.31 DM_CM_INFO2 Interrupt Mask Register (DM_CM_INFO2_MASK)

The DM_CM_INFO2 interrupt mask register (DM_CM_INFO2_MASK) enables or disables the DM_CM_INFO2 interrupt. When 0 is set in DM_CM_INFO2_MASK while the corresponding flag in DM_CM_INFO2 is set, an interrupt occurs.

Bit	Bit Name	Initial Value	R/W	Description
63 to 32	—	All 0	R	Reserved These bits are always read as 0. The write value should always be 0. Operation is not guaranteed if a value other than 0 is written to these bits.
31 to 20	—	All 1	R	Reserved These bits are always read as 1. The write value should always be 1. Operation is not guaranteed if a value other than 1 is written to these bits.
19, 18	—	11	R	Reserved The write value should always be 1.
17	DTRANERR1_MASK	1	R/W	DTRANERR1 interrupt masked
16	DTRANERR0_MASK	1	R/W	DTRANERR0 interrupt masked
15 to 1	—	All 1	R	Reserved These bits are always read as 1. The write value should always be 1. Operation is not guaranteed if a value other than 1 is written to these bits.
0	SEQERR_MASK	1	R/W	SEQERR interrupt masked

40.2.32 DMAC Transfer Address Register (DM_DTRAN_ADDR)

The DMAC Transfer Address Register (DM_DTRAN_ADDR) sets the transfer destination and source address of the module built-in DMAC.

Higher-order 32 bits (bit 63 to 32) are read only 0.

Bit	Bit Name	Initial Value	R/W	Description
63 to 32	—	All 0	R	Reserved These bits are always read as 0. The write value should always be 0. Operation is not guaranteed if a value other than 0 is written to these bits.
31 to 3	DADDR	All 0	R/W	Destination address / Source address (8 byte unit) Note that the value of DM_DTRAN_ADDR + transfer data length is less than or equal to 2^{32} .
2 to 0	—	All 0	R	Reserved These bits are always read as 0. The write value should always be 0. Operation is not guaranteed if a value other than 0 is written to these bits.

40.3 Operation

40.3.1 SD Interface

(1) SD Data Format

When data is read from the SD card, the procedure is as follows.

1. The SD/MMC host interface receives data from the SD card via the SDDAT signal. (SDDAT signal: see **Figure 40.2**, **Figure 40.3** and **Figure 40.4**.)
2. The receive data is stored in SD_BUF of the SD/MMC host interfaces. (SD_BUF store data: see **Figure 40.5**)
3. The data stored in SD_BUF is read from SD_BUF0. (Reading from SD_BUF0: see **Table 40.4**)

When data is written to the SD card, the above procedure will be reversed.

When accessing SD_BUF0, caution should be taken for the transfer order in SDDAT and the store order in SD_BUF. In addition, data stored in SD_BUF0 can be replaced in bytes with the EXT_SWAP. (See **Figure 40.5**)

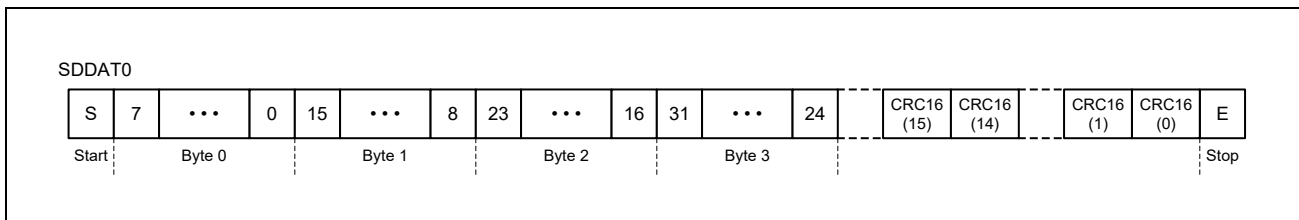

Figure 40.2 SDDAT in 1-Bit Width Mode

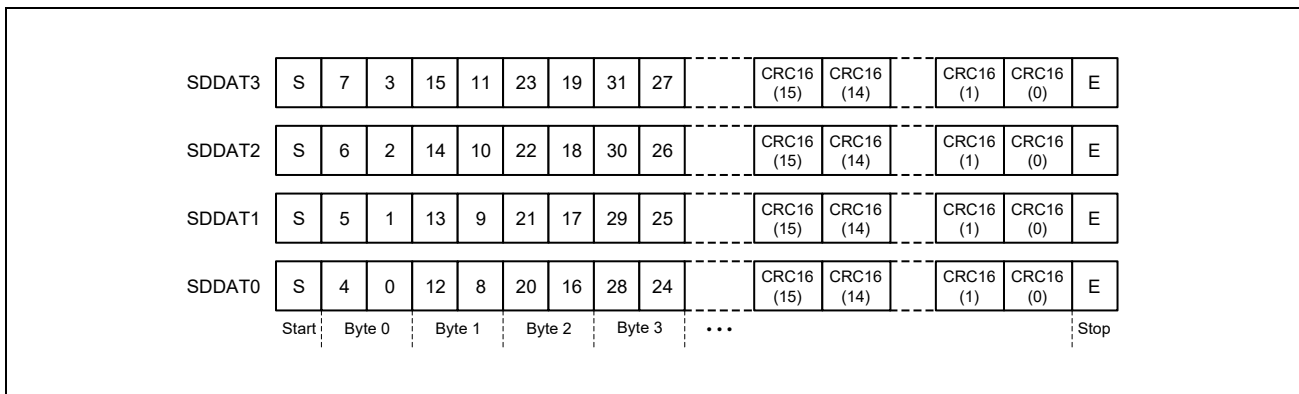

Figure 40.3 SDDAT in 4-Bit Width Mode

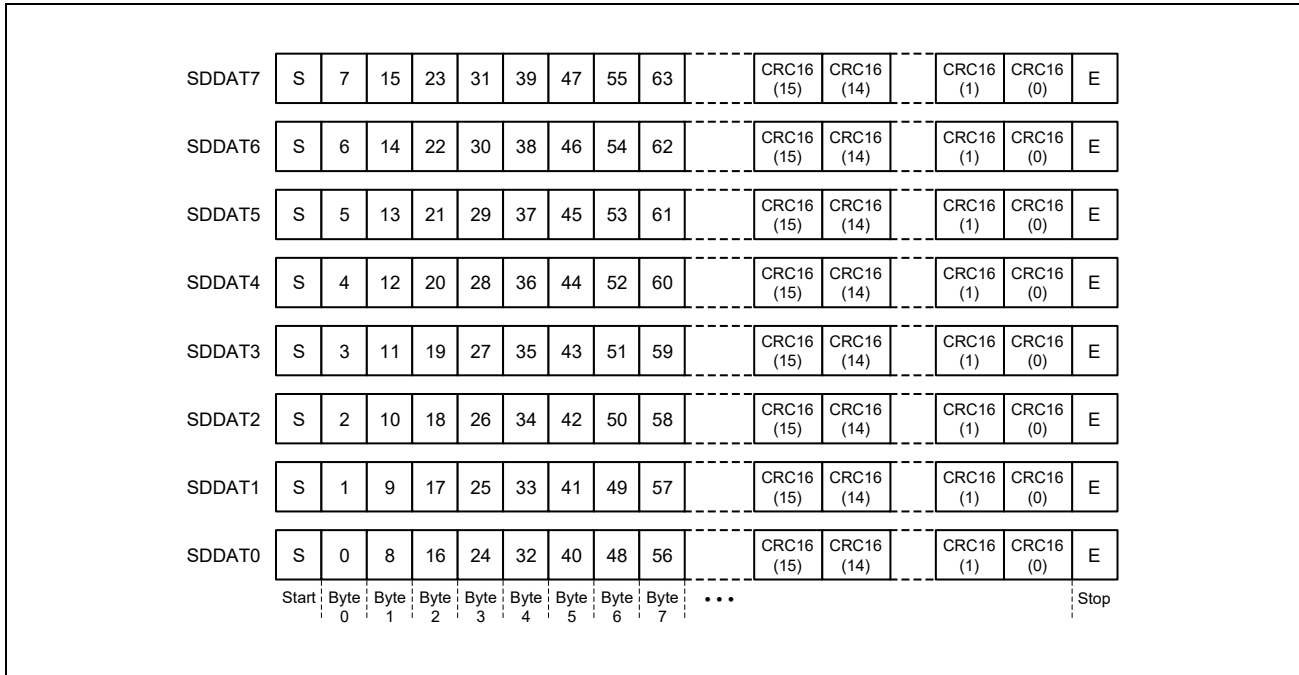

Figure 40.4 SDDAT in 8-Bit Width Mode

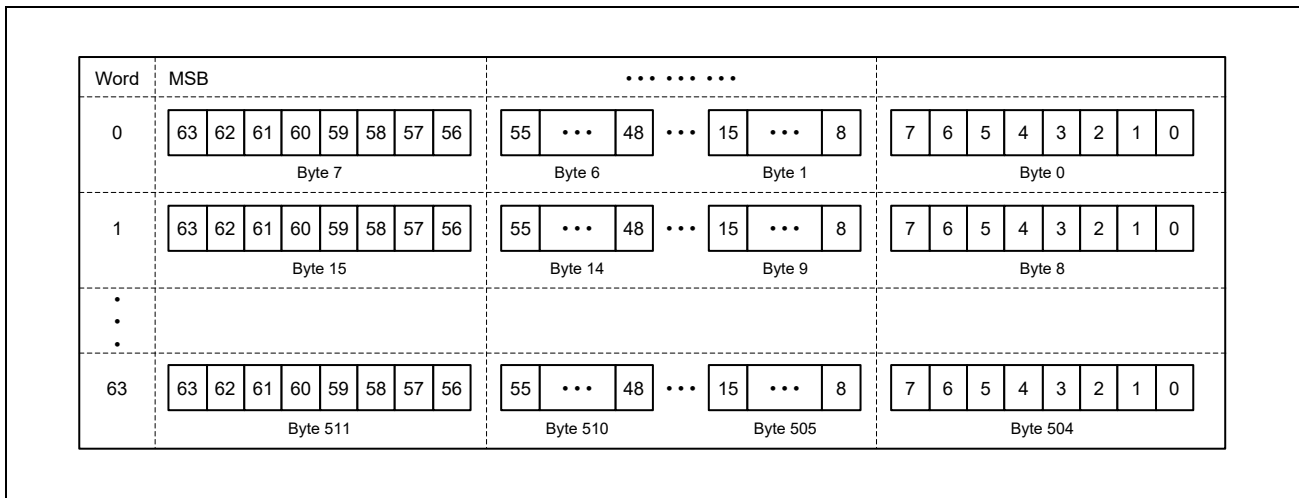

Figure 40.5 SD_BUF Store Data

Table 40.4 Reading from SD_BUF0

WMODE*1	BUSWIDTH*1	ENDIAN*1	Read Data*2
0	0	0	H'0123456789ABCDEF
0	0	1	H'EFCDAB8967452301
1	1	0	H'89ABCDEF (1st) H'01234567 (2nd)
1	1	1	H'EFCDAB89 (1st) H'67452301 (2nd)
1	0	0	H'CDEF (1st) H'89AB (2nd) H'4567 (3rd) H'0123 (4th)
1	0	1	H'EFCD (1st) H'AB89 (2nd) H'6745 (3rd) H'2301 (4th)

Note 1. The name of a bit in HOST_MODE.

Note 2. When the data stored in SD_BUF is H'0123456789ABCDEF

(2) Bus Signal Voltage Switch

Change the electric potential of the bus signal in the following procedure after checking that the SD card supports 1.8 V.

(1) Issuing CMD11

Perform command sequence processing of CMD11.

(2) Stopping the SD clock (a)

Set the SCLKEN bit in the SD_CLK_CTRL to 0 to stop*¹ the output of the SD clock. When the SDCLKOFFEN bit in the SD_CLK_CTRL register is 1, the SDCLKOFFEN bit is also set to 0.

Note 1. When the SDCLKOFFEN bit in the SD_CLK_CTRL register is 1, the SD clock has automatically been stopped.

(3) Checking the value of SDDAT

Check that the DAT0 bit in the SD_INFO2 register is 0.

(4) Changing the supply voltage of the host device

Change the voltage which is supplied through the power supply pin of the given channel (SD0_PVDD for channel 0 or SD1_PVDD for channel 1) from 3.3 V to 1.8 V.

For details, see the following sections:

Section 41.3.4, Port Function Control Register,

Section 41.3.7, Driving Ability Control Register,

Section 41.3.17, SD ch0 IO Voltage Mode Control Register,

Section 41.3.18, SD ch1 IO Voltage Mode Control Register.

(5) Starting supply of the SD clock (b)

After the SD clock has been stopped ((a) above) and 5 ms or more has elapsed, set the SCLKEN bit in the SD_CLK_CTRL register to 1 and allow the output of the SD clock. The SDCLKOFFEN bit must be 0.

(6) Checking the value of SDDAT

After supplying the SD clock has been started ((b) above) and 1 ms or more has elapsed, check that the DAT0 bit in the SD_INFO2 register is 1. It is possible to set the SDCLKOFFEN bit in the SD_CLK_CTRL register to 1 and allow SD Clock (SDCLK) Output Automatic Control Enable.

40.3.2 Card Detect/Write Protect

(1) Card Detect

The SD/MMC host interface has two types of card detect functions as described in the following.

- Card detect with ISDCD

Figure 40.6 shows the timing chart of card detect using ISDCD. ISDCD is connected to the card socket and pulled up on the host device. The resistance of the pull-up resistor is decided by the specification of the SD host device.

[Card insertion]

ISDCD is pulled down when a card is inserted. At this time, if ISDCD has been pulled down for the Mcycle period (set in SD_OPTION), INFO4 in SD_INFO1 is set to 1. (It is cleared to by writing 0.)

[Card removal]

ISDCD is pulled up when a card is removed. At this time, if ISDCD has been pulled up for the Mcycle period (set in SD_OPTION), INFO3 in SD_INFO1 is set to 1. (It is cleared to by writing 0.)

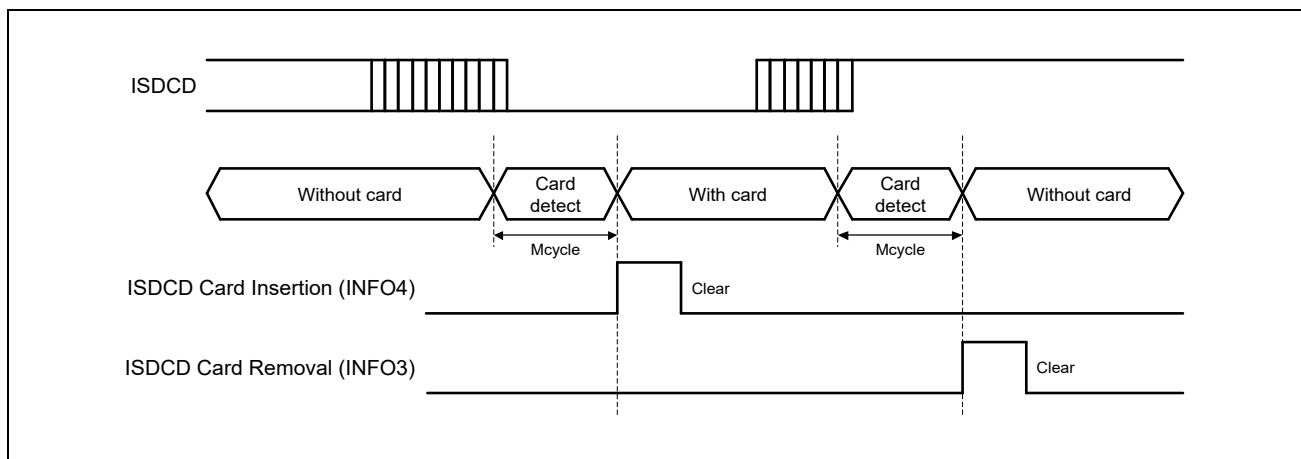

Figure 40.6 Example of Card Detect with ISDCD

- SD card detect with SDDAT3

Figure 40.7 shows the timing chart when the SD card is detected using SDDAT3. In addition, SDDAT3 is pulled down on the host device. The resistance of the pull-down resistor is decided by the specification of the SD host device.

[Card insertion]

When an SD card is inserted, SDDAT3 is pulled up. Accordingly, INFO9 in SD_INFO1 is set to 1. (It is cleared to 0 by writing 0.)

[Card removal]

When an SD card is removed, SDDAT3 is pulled down. Accordingly, INFO8 in SD_INFO1 is set to 1. (It is cleared to 0 by writing 0.)

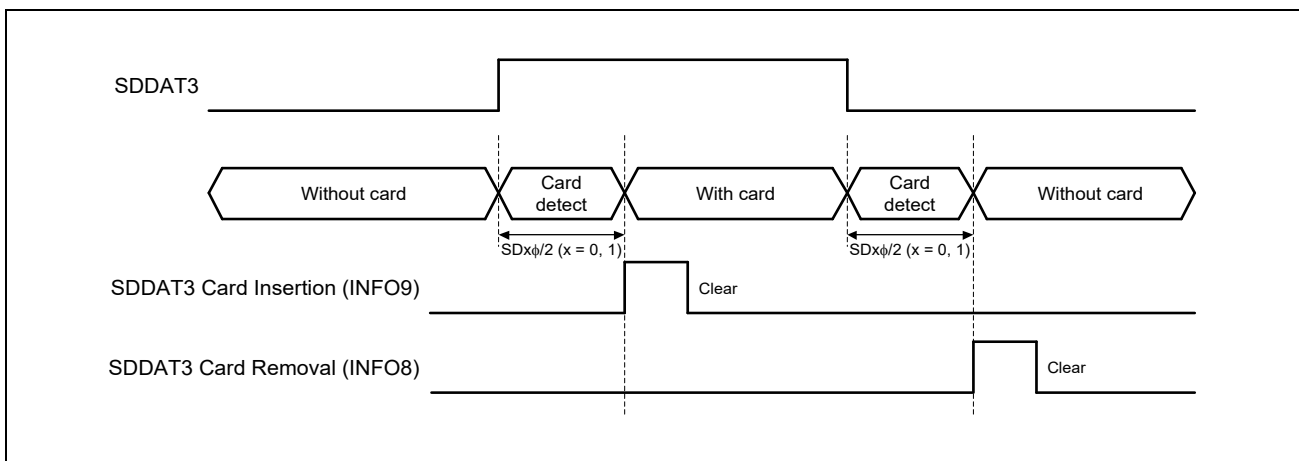

Figure 40.7 SD Card Detect with SDDAT3

(2) Write Protect

The SD/MMC host interface has two types of write protect functions.

- Write protect with ISDWP

ISDWP is connected to the card socket, and pulled up or pulled down by the card insertion. The selection of pulling up or pulling down and the resistance value is decided by the specifications of the SD host device. As the ISDWP state is reflected to INFO7 in SD_INFO1, the write protect is decided after the SD card is inserted.

- Write protect with command

The card's internal write protection and the card lock/unlock operation are realized by the command.

40.3.3 Interrupt Request

(1) Interrupt Request

The SD/MMC host interface has the interrupt requests shown in **Table 40.5** shows the relationship between the interrupt flag registers and the interrupt mask registers. When a bit in an interrupt mask register is set to 0, an interrupt occurs by setting the corresponding bit in the interrupt flag register to 1.

To clear a flag, write 0 to the bit to be cleared and 1 to the other bits.

Table 40.5 Interrupt Request

Interrupt Request	Interrupt Flag Register		Interrupt Mask Register	
	Register Name	Bit Name	Register Name	Bit Name
Card access interrupt*1	SD_INFO1	INFO2	SD_INFO1_MASK	IMASK2
		INFO0		IMASK0
	SD_INFO2	ILA	SD_INFO2_MASK	IMASK
		BWE		BMASK1
		BRE		BMASK0
		ERR6		EMASK6
		ERR5		EMASK5
		ERR4		EMASK4
		ERR3		EMASK3
		ERR2		EMASK2
		ERR1		EMASK1
		ERR0		EMASK0
	SDIO access interrupt*2	SDIO_INFO1	EXWT	SDIO_INFO1_MASK
EXPUB52			MEXPUB52	
IOIRQ			IOMSK	
Card detect interrupt*1	SD_INFO1	INFO9	SD_INFO1_MASK	IMASK9
		INFO8		IMASK8
		INFO4		IMASK4
		INFO3		IMASK3
DMAC interrupt*1	DM_CM_INFO1	DTRANEND1	DM_CM_INFO1_MASK	DTRANEND1_MASK
		DTRANEND0		DTRANEND0_MASK
		SEQEND		SEQEND_MASK
	DM_CM_INFO2	DTRANERR1	DM_CM_INFO2_MASK	DTARERR1_MASK
		DTRANERR0		DTARERR0_MASK
		SEQERR		SEQERR_MASK

Note 1. Interrupt signal "OXMNIRQ" is asserted.

Note 2. Interrupt signal both "OXMNIRQ" and "OXASIOIRQ" are asserted.

40.3.4 Communications Errors and Timeouts

- Communications Errors and Timeouts

Table 40.6 and **Table 40.7** show the relationships between the SD card interrupt flag register and SD error status register for communications errors and timeouts, respectively. When a bit in the SD card interrupt flag register is set to 1, the corresponding bit in the SD error status register is set to 1. The values of the SD error status register are cleared by writing to SD_CMD or writing 0 to the SDRST bit in SOFT_RST.

Table 40.6 Communications Errors

Communication Error	SD Interrupt Flag Register		SD Error Status Register		Description
	Register Name	Bit Name	Register Name	Bit Name	
END error	SD_INFO2	ERR2	SD_ERR_STS1	E5	When an error occurs in the CRC status length
				E4	When an error occurs in read data length
				E3	When an error occurs in the response length to a command issued within a command sequence
				E2	When an error occurs in the response length (other than a response to a command issued within a command sequence)
CRC error		ERR1		E11	When an error occurs in the CRC status
				E10	When a CRC error occurs in the read data
				E9	When a CRC error occurs in the response to a command issued within a command sequence
				E8	When a CRC error occurs in the response (other than a response to a command issued within a command sequence)
CMD error		ERR0		E1	The command index of the transmitted command differed from the command index of the received response (for a command issued within a command sequence)
				E0	The command index of the transmitted command differed from the command index of the received response (for a command issued other than within a command sequence)

Table 40.7 Timeouts

Timeout	SD Interrupt Flag Register		SD Error Status Register		Description
	Register Name	Bit Name	Register Name	Bit Name	
Response timeout	SD_INFO2	ERR6	SD_ERR_STS2	E1	When the response to a command issued within a command sequence is not received even after 640 cycles of SDCLK have elapsed
				E0	When the response (other than a response to a command issued within a command sequence) is not received even after 640 cycles of SDCLK have elapsed
Data timeout (other than response timeout)		ERR3		E6	When the interface remains in a busy state (SDDAT0 = 0) for at least Ncycle* ¹ after the CRC status
				E5	When the CRC status is not received t even after Ncycle* ¹ has elapsed after data writing
				E4	When read data is not received even after Ncycle* ¹ has elapsed after read command
					When read data for the next block are not received even after Ncycle* ¹ has elapsed after the reception of read data
					When read data for the next block are not received even after Ncycle* ¹ has elapsed after release of the read wait state
E3	When the interface remains in a busy state (SDDAT0 = 0) for at least Ncycle* ¹ after CMD12 has been issued within a command sequence				
E2	When the interface remains in a busy state (SDDAT0 = 0) for at least Ncycle* ¹ after R1b response				

Note 1. Ncycle is set by bit 7 to bit 4 in SD_OPTION.

40.4 Usage Example

40.4.1 Command without Data Transfer

(1) Flowchart

Figure 40.8 and Figure 40.9 show flowchart examples.

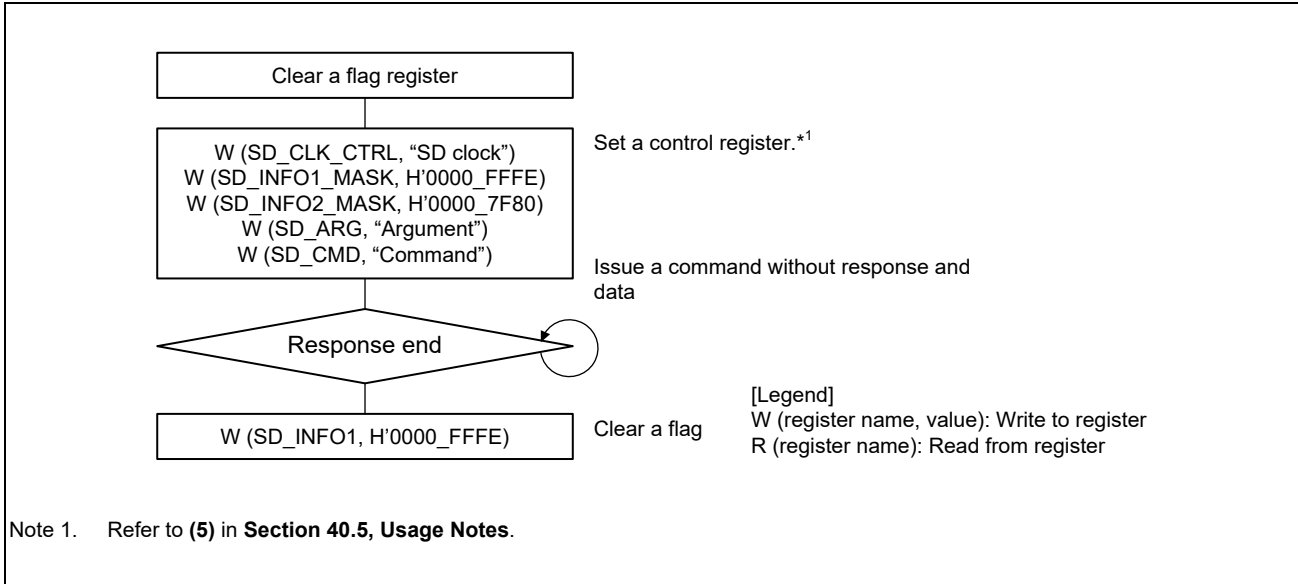

Figure 40.8 Flow Example of Command without Response and Data

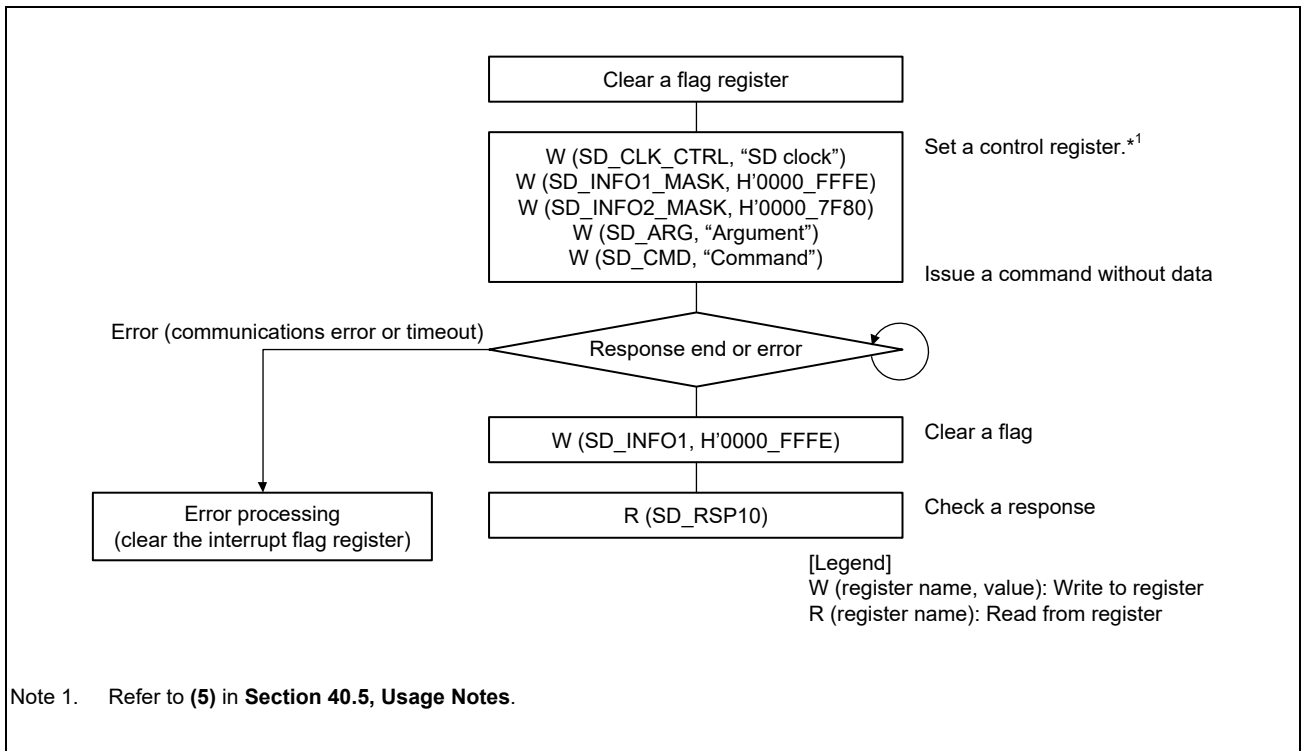

Figure 40.9 Flow Example of Command without Data

(2) Operation for Command without Data Transfer

The legend below is used for description of register read/write.

W (register name, value): Write to register

R (register name): Read from register

The operation is described as below.

(a) Command without response and data

1. Flag register clear
First, clear the bits in the flag register. (SD_INFO1 and SD_INFO2)
2. Control register set
Set the SD clock (SDCLK), interrupt mask, and so on. (SD_CLK_CTRL, SD_INFO1_MASK, and SD_INFO2_MASK)
3. Command issue
Set CMD Argument in SD_ARG and write to SD_CMD.
Accordingly, CMD is issued, and the operation is started.
4. Flag clear
When transmission of a command is completed, INFO0 (response end) in SD_INFO1 is set to 1 to generate an interrupt. Clear INFO0 to 0.

(b) Command without data

1. Flag register clear
First, clear the bits in the flag register. (SD_INFO1 and SD_INFO2)
2. Control register set
Set the SD clock (SDCLK), interrupt mask, and so on. (SD_CLK_CTRL, SD_INFO1_MASK, and SD_INFO2_MASK)
3. Command issue
Set CMD Argument in SD_ARG and write to SD_CMD.
Accordingly, CMD is issued, and the operation is started.
4. Flag clear
When a response is received, INFO0 (response end) in SD_INFO1 is set to 1 to generate an interrupt. Clear INFO0 to 0.
5. Read a response from SD_RSP10.
Furthermore, perform error processing (clear the interrupt flag register) if an error occurs (a communications error or timeout).

40.4.2 Single Block Read

(1) Flowchart

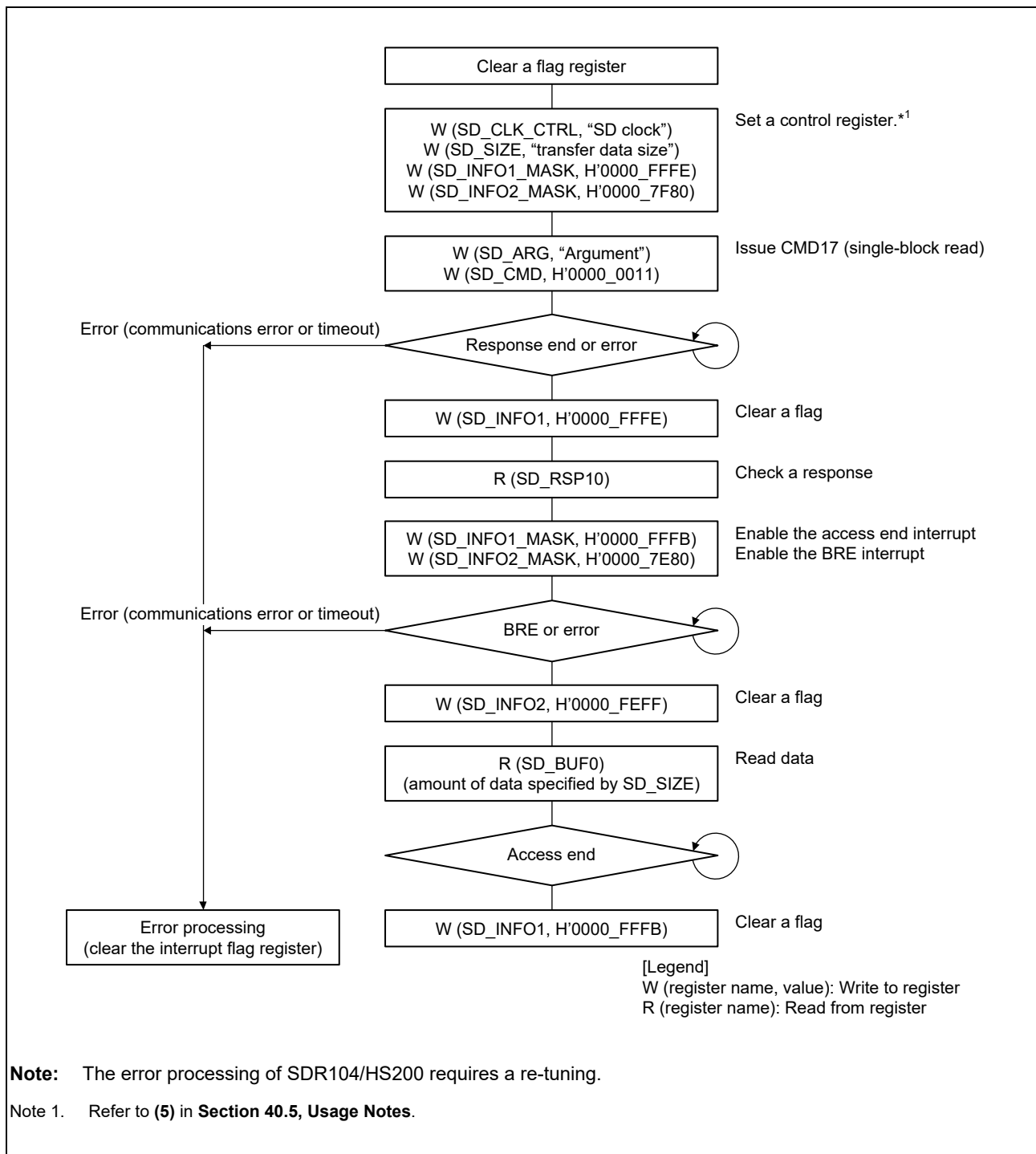

Figure 40.10 Single Block Read Flowchart Example

(2) Operation for Single Block Read

The operation of the single block read is described below.

1. Flag register clear
First, clear the bits in the flag register. (SD_INFO1 and SD_INFO2)
2. Control register set
Set the SD clock (SDCLK), transfer data size, interrupt mask, and so on. (SD_CLK_CTRL, SD_SIZE, SD_INFO1_MASK, and SD_INFO2_MASK)
3. Command issue (CMD17)
Set CMD17 Argument in SD_ARG and write H'0000 0011 to SD_CMD.
Accordingly, CMD17 is issued, and the single block read operation is started.
4. Response check
On receiving the response, INFO0 (response end) in SD_INFO1 is set to 1 to generate an interrupt. Clear INFO0 to 0 and read the response from SD_RSP10.
If the result of response decoding is an error, the command sequence can be halted by setting the STP bit in SD_STP or the IOABT bit in SDIO_MODE to 1. Furthermore, this causes CMD12 and CMD52 to not be issued. If the command sequence is halted, the INFO2 bit (access end) in SD_INFO1 is set to 1 to generate an interrupt.
5. Data receive from SD card and data read
Write H'0000 FFFB to SD_INFO1_MASK to enable the access end interrupt. In addition, write H'0000 7E80 to SD_INFO2_MASK to enable the BRE interrupt. When the data receive from the SD card is completed, the BRE bit in SD_INFO2 is set to 1 to generate an interrupt. Clear the BRE bit to 0 and read the amount of data specified by SD_SIZE from SD_BUF0.
However, a communications error or timeout may be generated if data are being received while reading of SD_BUF0 is in progress.
6. Operation complete
When the data read from SD_BUF0 is completed, INFO2 (access end) in SD_INFO1 is set to 1 to generate an interrupt. Clear INFO2 to 0 to end the single block read operation.

Furthermore, perform error processing (clear the interrupt flag register) if an error occurs (a communications error or timeout).

40.4.3 Single Block Write

(1) Flowchart

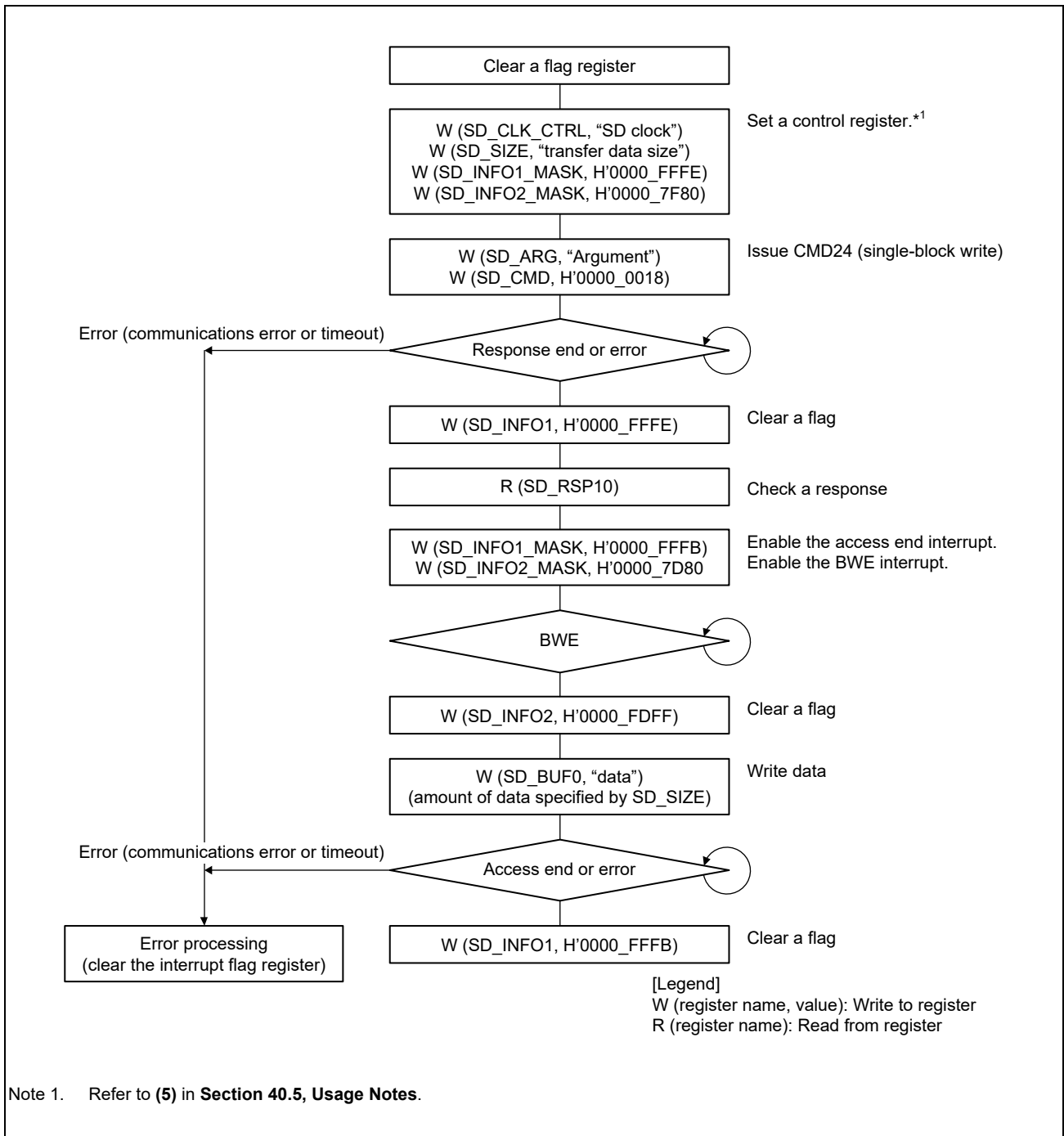

Figure 40.11 Single Block Write Flowchart Example

(2) Operation for Single Block Write

The operation of the single block write is described below.

1. Flag register clear
First, clear the bits in the flag register. (SD_INFO1 and SD_INFO2)
2. Control register set
Set the SD clock (SDCLK), transfer data size, interrupt mask, and so on. (SD_CLK_CTRL, SD_SIZE, SD_INFO1_MASK, and SD_INFO2_MASK)
3. Command issue (CMD24)
Set CMD24 Argument in SD_ARG and write H'0000 0018 to SD_CMD.
Accordingly, CMD24 is issued, and the single block write operation is started.
4. Response check
On receiving the response, INFO0 (response end) in SD_INFO1 is set to 1 to generate an interrupt. Clear INFO0 to 0 and read the response from SD_RSP10.
If the result of response decoding is an error, the command sequence can be halted by setting the STP bit in SD_STP or the IOABT bit in SDIO_MODE to 1. Furthermore, this causes CMD12 and CMD52 to not be issued. If the command sequence is halted, the INFO2 bit (access end) in SD_INFO1 is set to 1 to generate an interrupt.
5. Data write and data transmit to SD card
Write H'0000 FFFB to SD_INFO1_MASK to enable the access end interrupt. In addition, write H'0000 7D80 to SD_INFO2_MASK to enable the BWE interrupt. When SD_BUF0 is ready for the data to be written, the BWE bit in SD_INFO2 is set to 1 to generate an interrupt. Clear the BWE bit to 0 and write the amount of data specified by SD_SIZE to SD_BUF0. When the data write to SD_BUF0 is completed, data is transmitted to the SD card. Then, the CRC status and busy state are received from the SD card.
However, a communications error or timeout may be generated if data are being transmitted after writing to SD_BUF0.
6. Operation complete
When the CRC status and busy state are received from the SD card, INFO2 (access end) in SD_INFO1 is set to 1 to generate an interrupt. Clear the INFO2 bit to 0 to end the single block write operation.

Furthermore, perform error processing (clear the interrupt flag register) if an error occurs (a communications error or timeout).

40.4.4 Multiple Block Read

(1) Flowchart

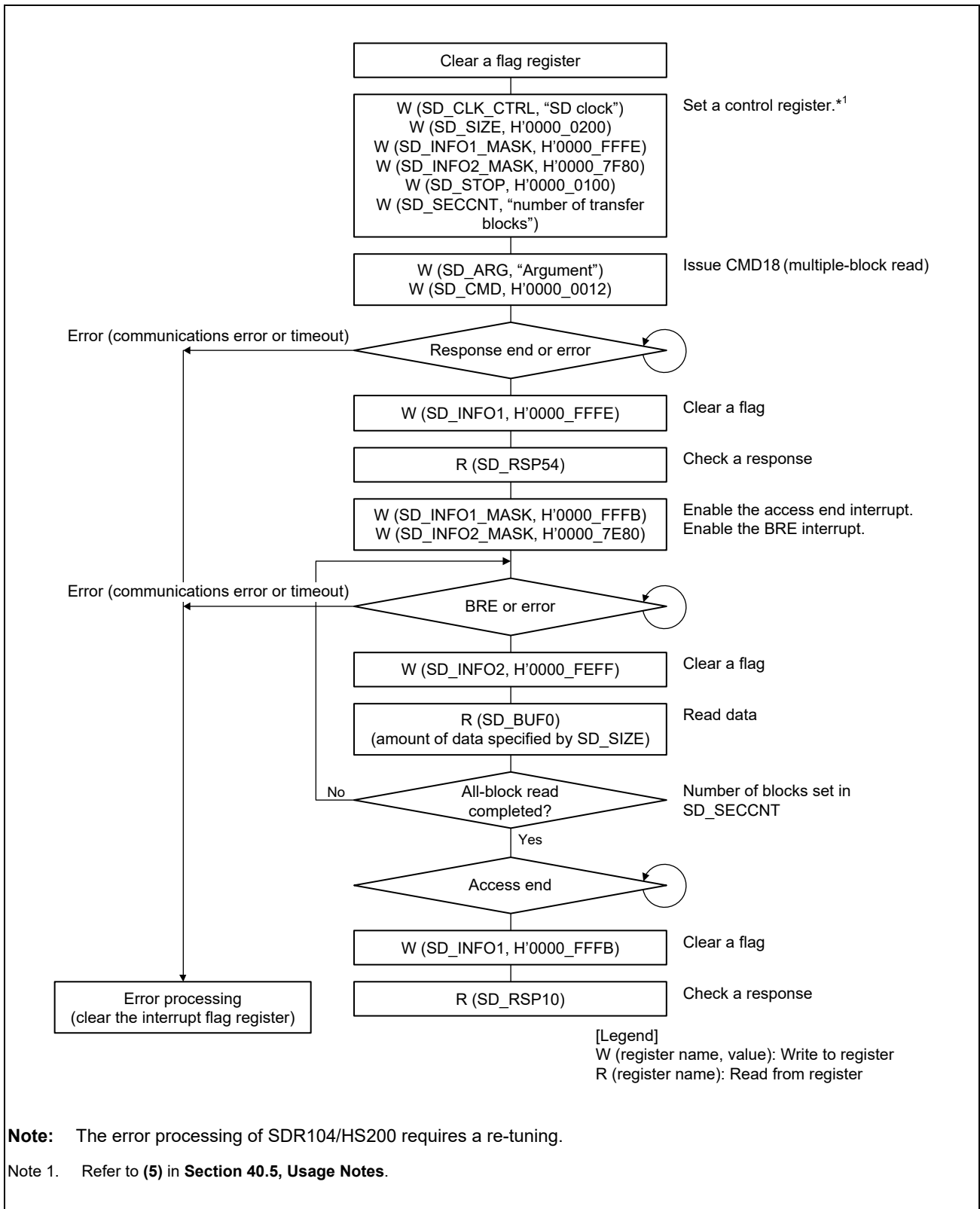

Figure 40.12 Multiple Block Read Flowchart Example

(2) Operation for Multiple Block Read

The operation of the multiple block read is described below.

1. Flag register clear
First, clear the bits in the flag register. (SD_INFO1 and SD_INFO2)
2. Control register set
Set the SD clock (SDCLK), transfer data size, interrupt mask, and so on. (SD_CLK_CTRL, SD_SIZE, SD_INFO1_MASK, and SD_INFO2_MASK)
Set the SEC bit in SD_STOP to 1, and set the number of transfer blocks in SD_SECCNT.
3. Command issue (CMD18)
Set CMD18 Argument in SD_ARG and write H'0000 0012 to SD_CMD.
Accordingly, CMD18 is issued, and the multiple block read operation is started.
4. Response check
On receiving the response, INFO0 (response end) in SD_INFO1 is set to 1 to generate an interrupt. Clear INFO0 to 0 and read the response from SD_RSP54.
If the result of response decoding is an error, the command sequence can be halted by setting the STP bit in SD_STP to 1. Setting the STP bit to 1 also causes CMD12 to be issued and the response received. If the command sequence is halted because the access end interrupt has been enabled, an interrupt will be generated by setting of the INFO2 bit (access end) in SD_INFO1 to 1 when reception of the response has been completed. Clear the INFO2 bit to 0 and read the response.
5. Data receive from SD card and data read
Write H'0000 FFFB to SD_INFO1_MASK to enable the access end interrupt. In addition, write H'0000 7E80 to SD_INFO2_MASK to enable the BRE interrupt. When one-block data receive from the SD card is completed, the BRE bit in SD_INFO2 is set to 1 to generate an interrupt. Clear the BRE bit to 0 and read the amount of data specified by SD_SIZE from SD_BUF0. Doing this repeats transfer of the number of blocks set in SD_SECCNT. However, a communications error or timeout may be generated if data are being received while reading of SD_BUF0 is in progress. CMD12 is automatically issued to stop multi-block transfer with the number of blocks which is set to SD_SECCNT and the response is received. At this point, CMD12 Argument is automatically set to H'0000 000.
6. Operation complete
When all-block data read and the CMD12 response receive are completed, INFO2 (access end) in SD_INFO1 is set to 1 to generate an interrupt. Clear INFO2 to 0 to read the response. This is the end of multiple block read operation.

Furthermore, perform error processing (clear the interrupt flag register) if an error occurs (a communications error or timeout).

40.4.5 Multiple Block Write (when Using Internal Timer)

(1) Flowchart

Figure 40.13 shows the flowchart when using an internal timer.

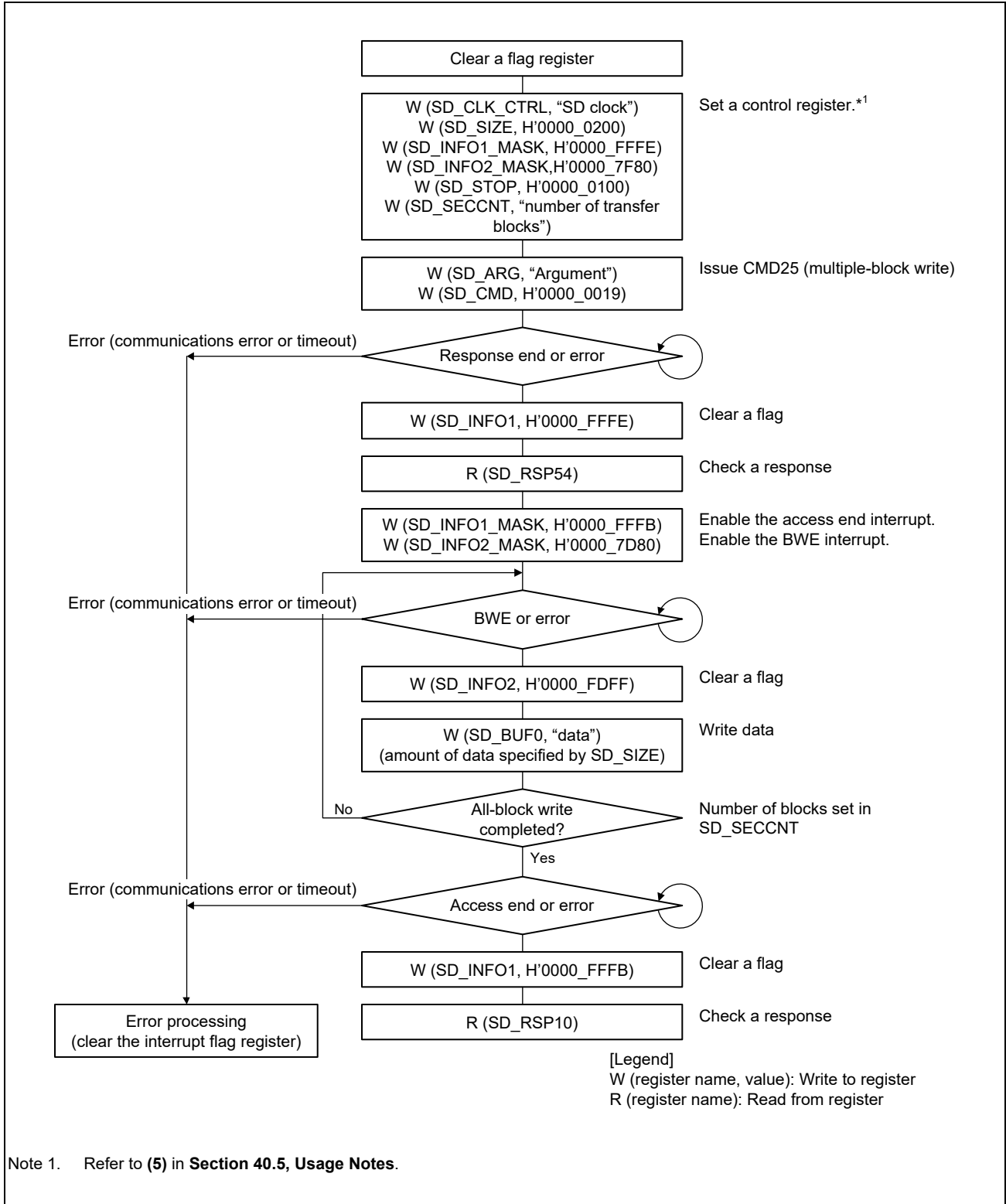

Figure 40.13 Multiple Block Write Flowchart Example (when Using Internal Timer)

(2) Operation for Multiple Block Write

The operation of the multiple block write is described below.

1. Flag register clear
First, clear the bits in the flag register. (SD_INFO1 and SD_INFO2)
2. Control register set
Set the SD clock (SDCLK), transfer data size, interrupt mask, and so on. (SD_CLK_CTRL, SD_SIZE, SD_INFO1_MASK, and SD_INFO2_MASK)
Set the SEC bit in SD_STOP to 1, and set the number of transfer blocks in SD_SECCNT.
3. Command issue (CMD25)
Set CMD25 Argument in SD_ARG and write H'0000 0019 to SD_CMD.
Accordingly, CMD25 is issued, and the multiple block write operation is started.
4. Response check
On receiving the response, INFO0 (response end) in SD_INFO1 is set to 1 to generate an interrupt. Clear INFO0 to 0 and read the response from SD_RSP54.
If the result of response decoding is an error, the command sequence can be halted by setting the STP bit in SD_STP to 1. Setting the STP bit to 1 also causes CMD12 to be issued and the response received. If the command sequence is halted because the access end interrupt has been enabled, an interrupt will be generated by setting of the INFO2 bit (access end) bit in SD_INFO1 to 1 when reception of the response has been completed. Clear the INFO2 bit to 0 and read the response.
5. Data write and data transmit to SD card
Write H'0000 FFFB to SD_INFO1_MASK to enable the access end interrupt. In addition, write H'0000 7D80 to SD_INFO2_MASK to enable the BWE interrupt. When SD_BUF0 is ready for the data to be written, the BWE bit in SD_INFO2 is set to 1 to generate an interrupt. Clear the BWE bit to 0 and write the amount of data specified by SD_SIZE to SD_BUF0. When the data write to SD_BUF0 is completed, data is transmitted to the SD card. Then, the CRC status and busy state are received from the SD card. Doing this repeats transfer of the number of blocks set in SD_SECCNT.
However, a communications error or timeout may be generated if data are being transmitted while writing to SD_BUF0 is in progress. CMD12 is automatically issued to stop multi-block transfer with the number of blocks which is set to SD_SECCNT and the response is received. At this point, CMD12 Argument is automatically set to H'0000 0000.
6. Operation complete
When all-block data transmit and the CRC status receive are completed, the INFO2 bit (access end) in SD_INFO1 is set to 1 to generate an interrupt. Clear the INFO2 bit to 0 to read the response. This is the end of multiple block write operation.

Furthermore, perform error processing (clear the interrupt flag register) if an error occurs (a communications error or timeout).

40.4.6 Multiple Block Write (when Using External Timer)

(1) Flowchart

The flowchart when using an external timer instead of an internal timer of this module is shown below.

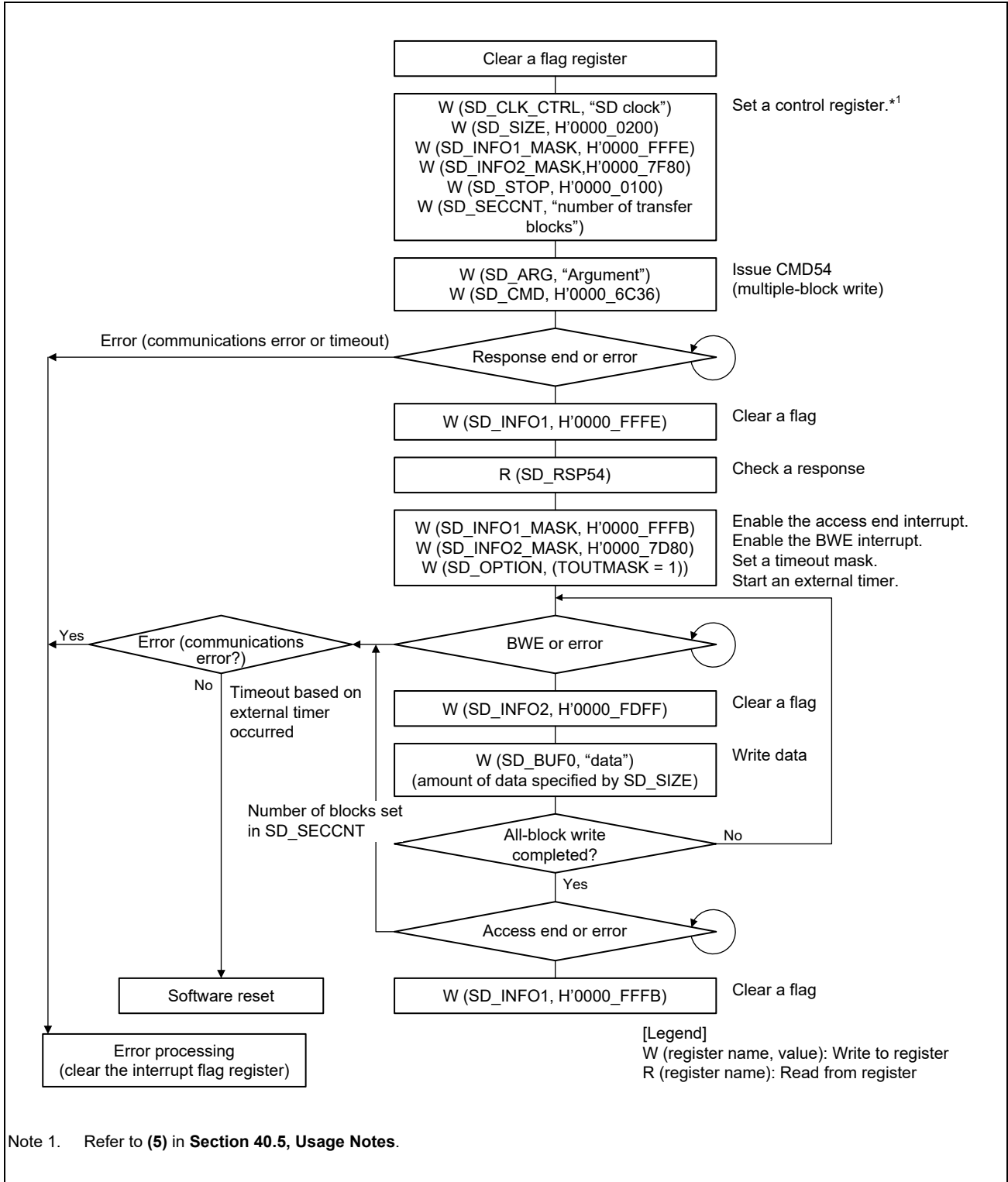

Figure 40.14 Multiple Block Write Flowchart Example (when Using External Timer)

(2) Operation for Multiple Block Write

The operation of the multiple block write is described below.

1. Flag register clear
First, clear the bits in the flag register. (SD_INFO1 and SD_INFO2)
2. Control register set
Set the SD clock (SDCLK), transfer data size, interrupt mask, and so on. (SD_CLK_CTRL, SD_SIZE, SD_INFO1_MASK, and SD_INFO2_MASK)
Set the SEC bit in SD_STOP to 1, and set the number of transfer blocks in SD_SECCNT.
3. Command issue (CMD54)
Set CMD54 Argument in SD_ARG and write H'0000 6C36 to SD_CMD.
Accordingly, CMD54 is issued, and the multiple block write operation is started.
4. Response check
On receiving the response, INFO0 (response end) in SD_INFO1 is set to 1 to generate an interrupt. Clear INFO0 to 0 and read the response from SD_RSP54.
If the result of response decoding is an error, the command sequence can be halted by setting the STP bit in SD_STP to 1. Setting the STP bit to 1 also causes CMD12 to be issued and the response received. If the command sequence is halted because the access end interrupt has been enabled, an interrupt will be generated by setting of the INFO2 bit (access end) bit in SD_INFO1 to 1 when reception of the response has been completed. Clear the INFO2 bit to 0 and read the response.
5. Data write and data transmit to SD card
Write H'0000 FFFB to SD_INFO1_MASK to enable the access end interrupt. In addition, write H'0000 7D80 to SD_INFO2_MASK to enable the BWE interrupt. Set the TOUTMASK bit in SD_OPTION to disable timeout and start an external timer.
When SD_BUF0 is ready for the data to be written, the BWE bit in the SD_INFO2 register is set to 1 to generate an interrupt. Clear the BWE bit to 0 and write the amount of data specified by SD_SIZE to SD_BUF0. When the data write to SD_BUF0 is completed, data is transmitted to the SD card. Then, the CRC status and busy state are received from the SD card. Doing this repeats transfer of the number of blocks set in SD_SECCNT. However, a communications error may be generated if data are being transmitted while writing to SD_BUF0 is in progress.
6. Operation complete
When all-block data transmit and the CRC status receive are completed, the INFO2 bit (access end) in SD_INFO1 is set to 1 to generate an interrupt. Clear the INFO2 bit to 0 to read the response. This is the end of multiple block write operation.

Furthermore, perform error processing (clear the interrupt flag register) if an error occurs at response reception (a communications error or timeout) or at data transmission. Perform a software reset if a timeout occurs at data transmission based on an external timer.

40.4.7 IO_RW_DIRECT Command (CMD52)

(1) Flowchart

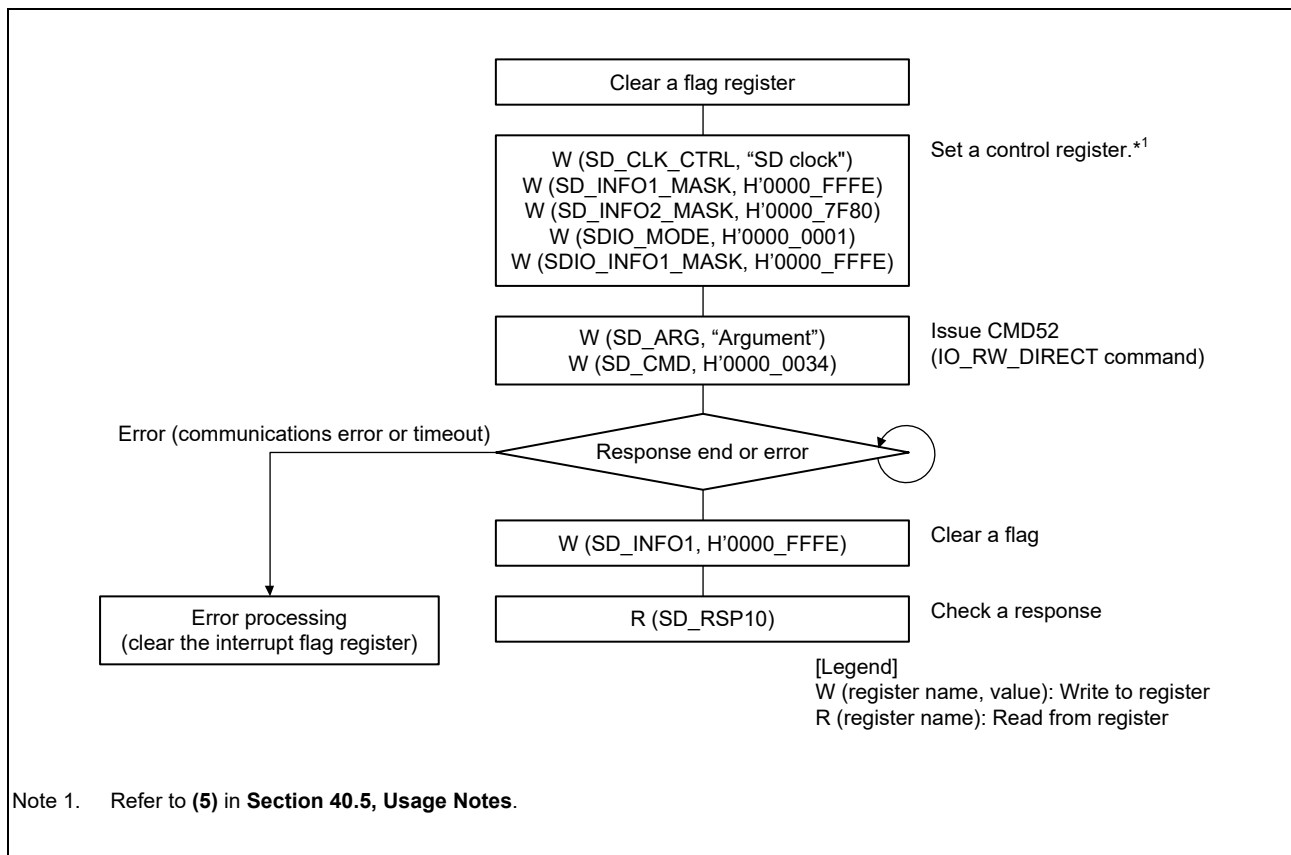

Figure 40.15 IO_RW_DIRECT Command (CMD52) Flowchart Example

40.4.8 IO_RW_EXTENDED (CMD53/Multiple Block Read)

(1) Flowchart

Figure 40.16 shows a flowchart example for CMD53 (multiple block read).

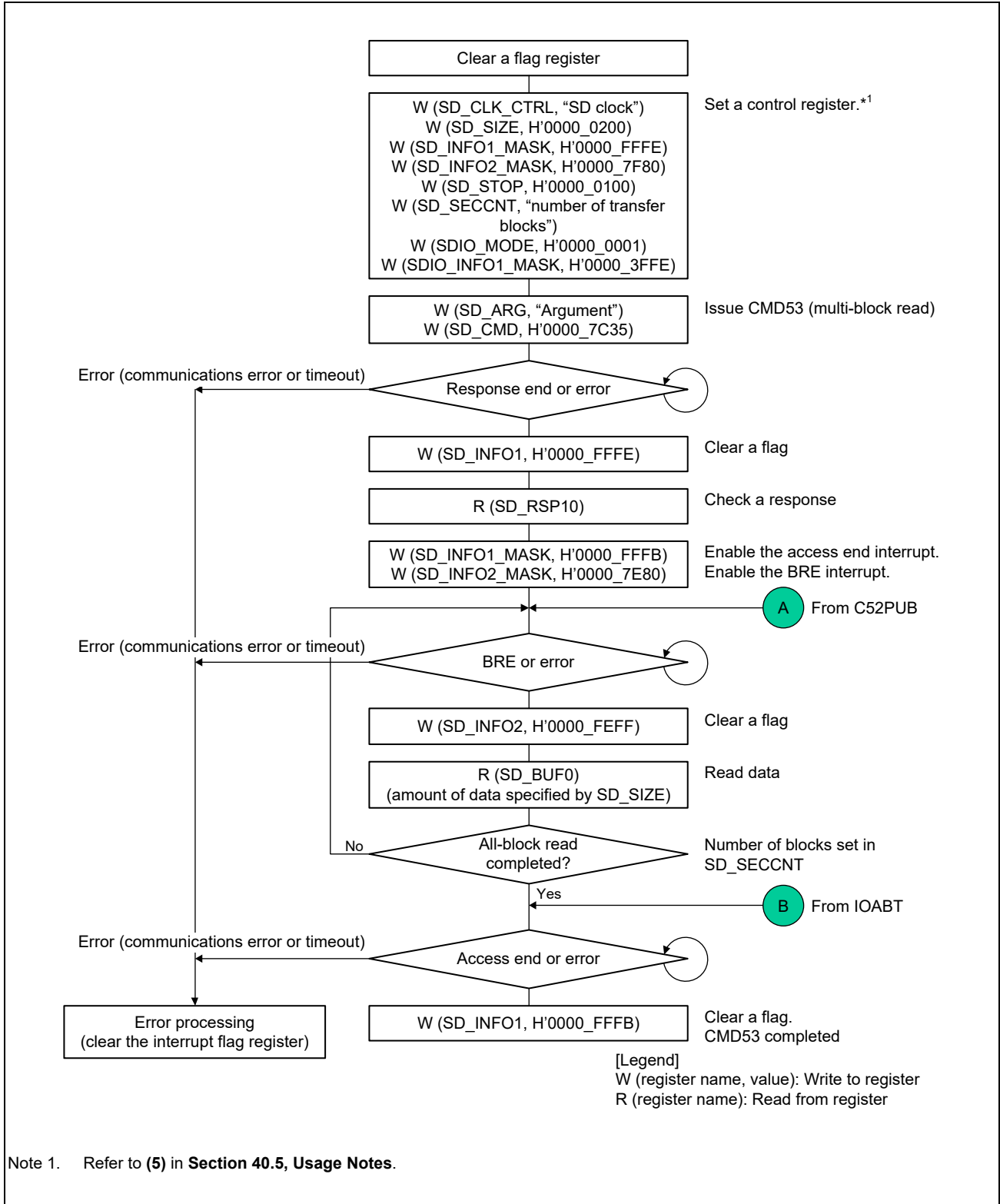

Figure 40.16 CMD53 (Multiple Block Read) Flowchart Example

Figure 40.17 shows a flowchart example when CMD52 (SDIO abort) is issued at CMD53 (multiple block read).

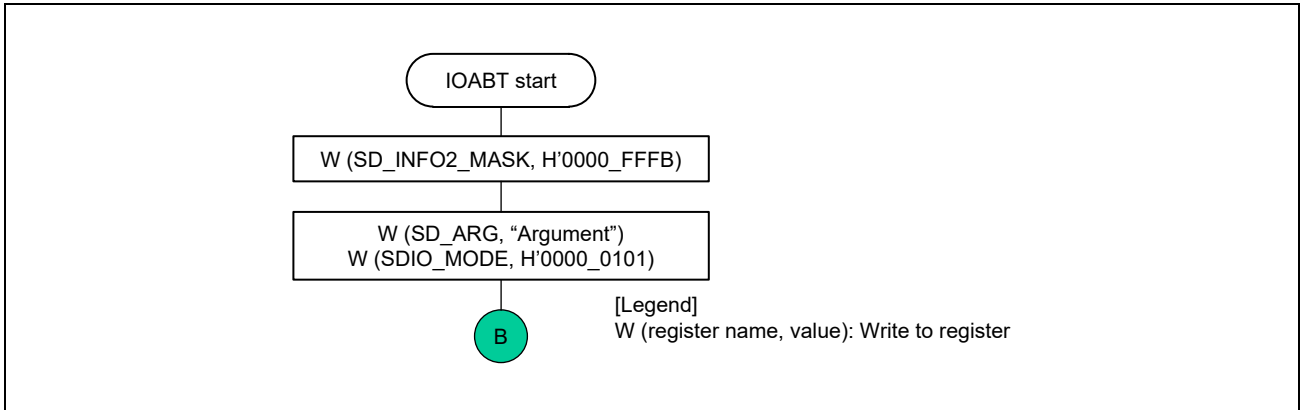

Figure 40.17 Flowchart Example when CMD52 (SDIO Abort) is Issued at CMD53 (Multiple Block Read)

Figure 40.18 shows a flowchart example when CMD52 (SDIO none abort) is issued at CMD53 (multiple block read) while the SD/MMC host interface is in the read wait state.

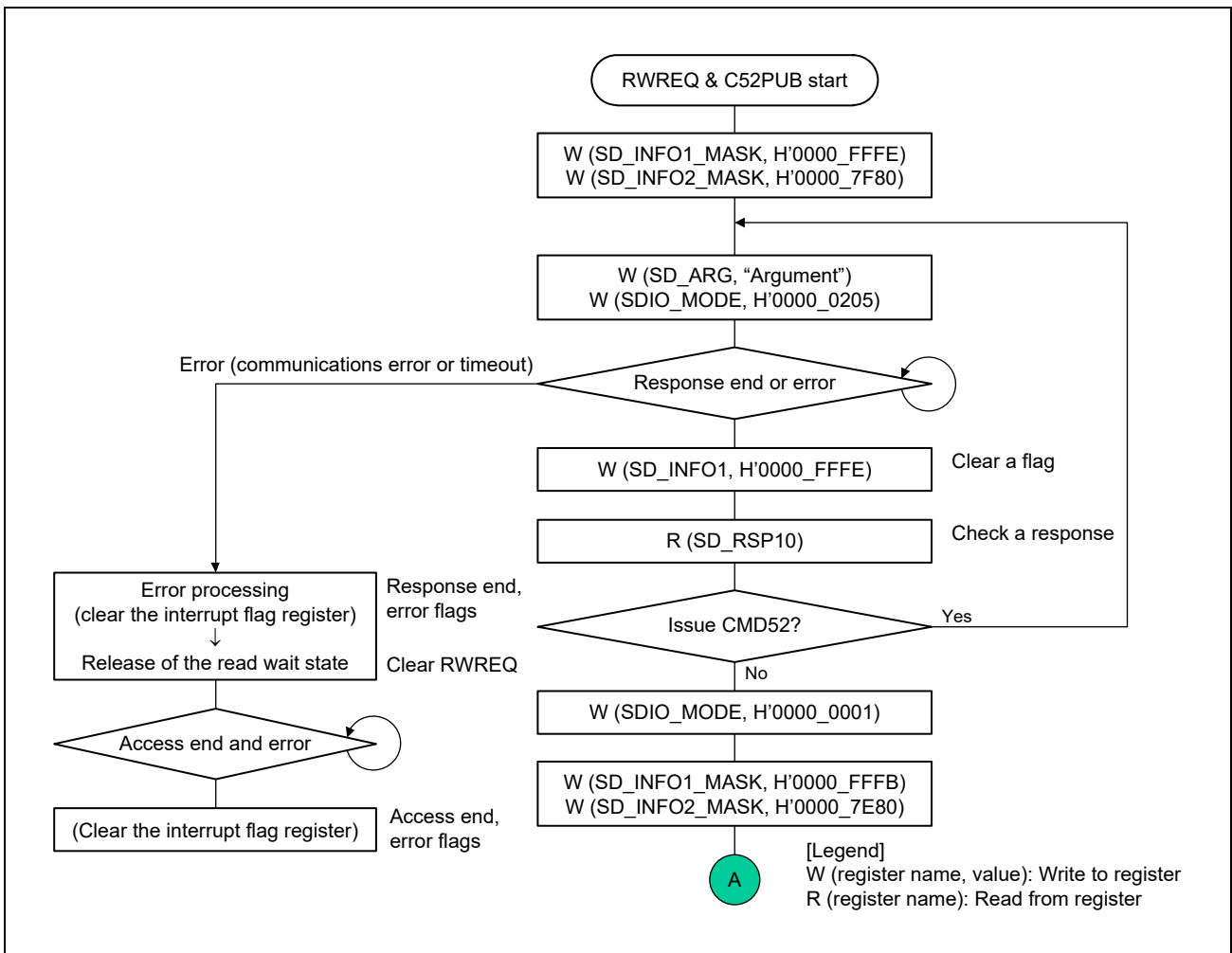

Figure 40.18 Flowchart Example when CMD52 (SDIO None Abort) is Issued after Read Wait State is Entered at CMD53 (Multi Block Read)

40.4.9 IO_RW_EXTENDED (CMD53/Multiple Block Write)

(1) Flowchart

Figure 40.19 shows a flowchart example for CMD53 (multiple block write).

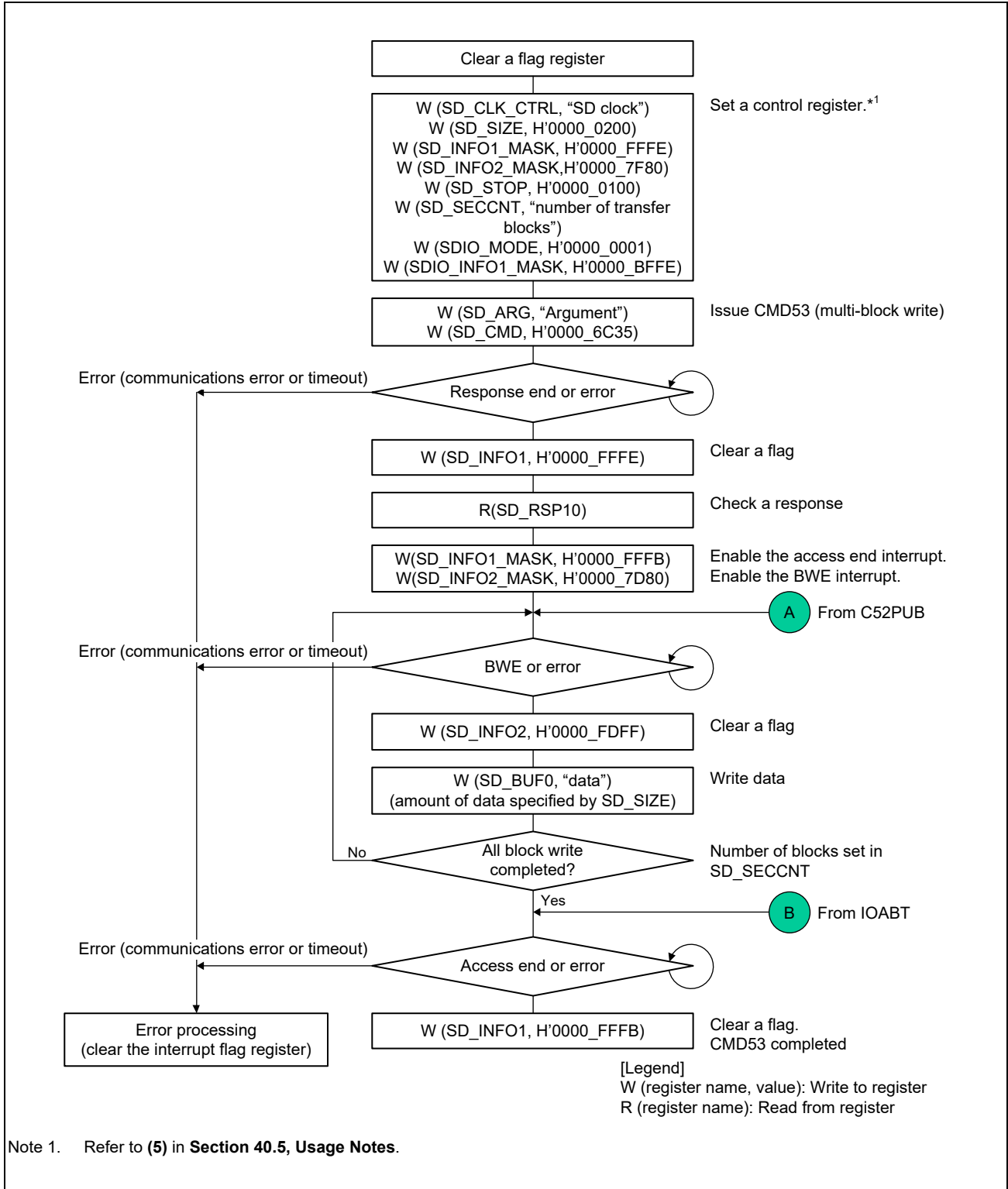

Figure 40.19 CMD53 (Multiple Block Write) Flowchart Example

Figure 40.20 shows a flowchart example when CMD52 (SDIO abort) is issued at CMD53 (multiple block write).

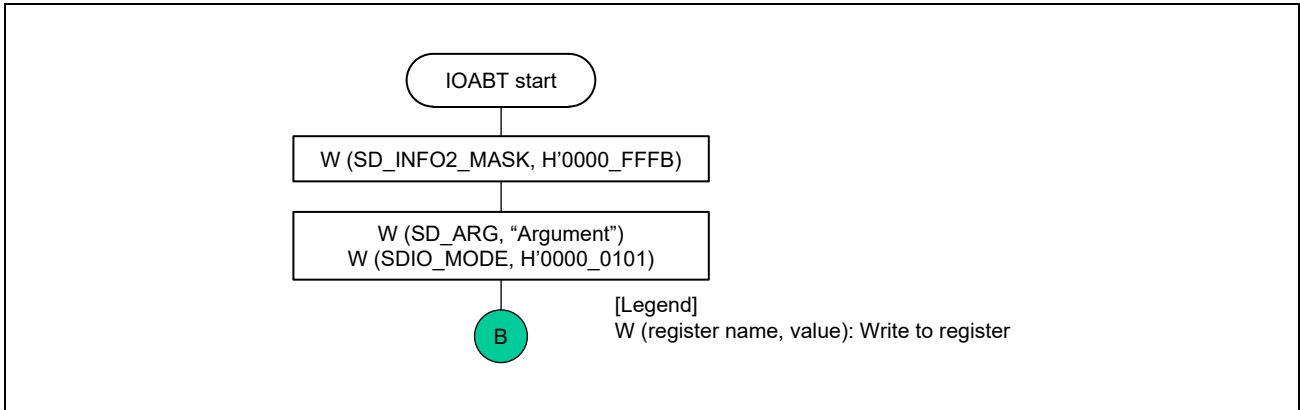

Figure 40.20 Flowchart Example when CMD52 (SDIO Abort) is Issued at CMD53 (Multiple Block Write)

Figure 40.21 shows a flowchart example when CMD52 (SDIO none abort) is issued at CMD53 (multiple block write).

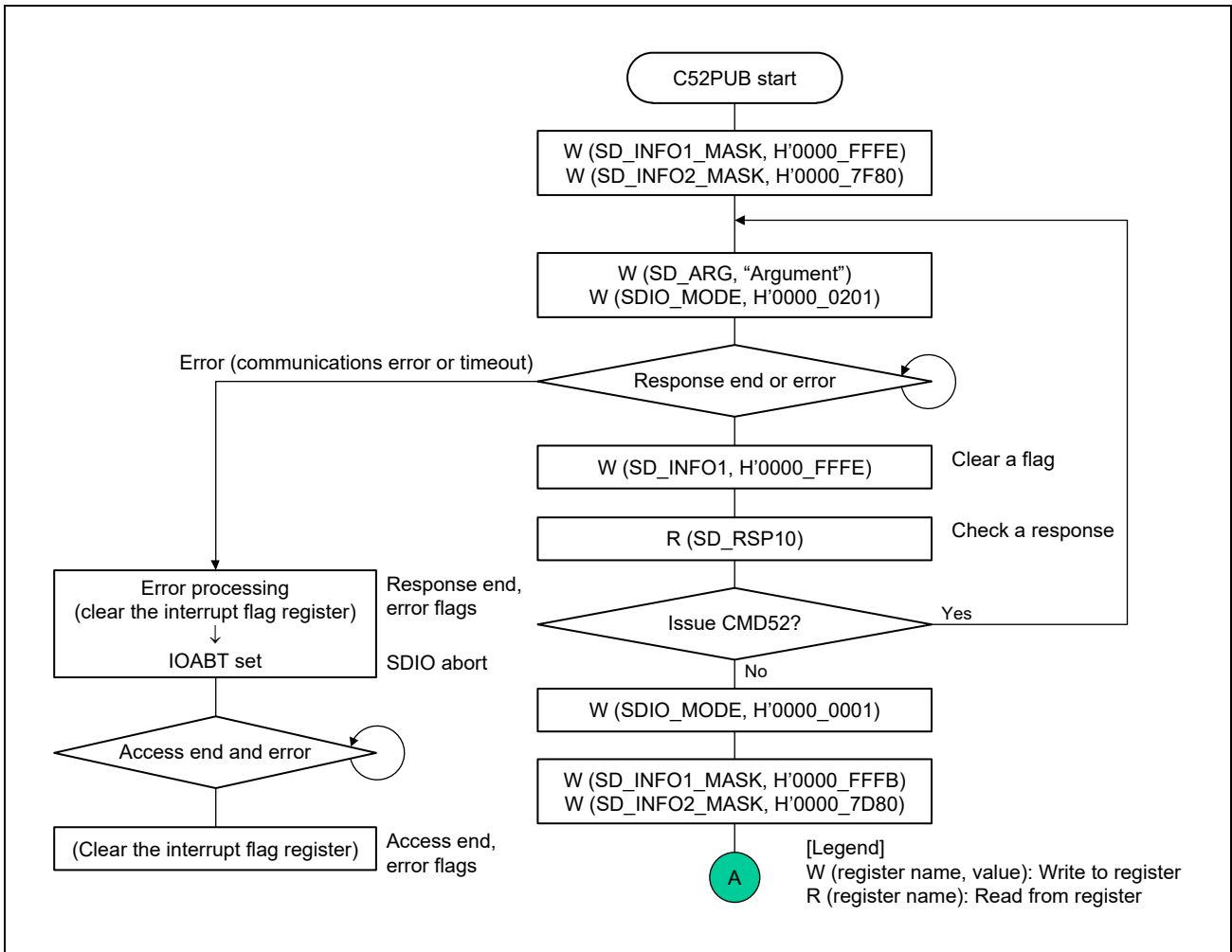

Figure 40.21 Flowchart Example when CMD52 (SDIO None Abort) is Issued at CMD53 (Multiple Block Write)

40.4.10 DMA Transfer

(1) SD_BUF DMA Transfer

Figure 40.22 shows a flowchart example for SD_BUF DMA read when CMD18 (multiple block read) is issued.

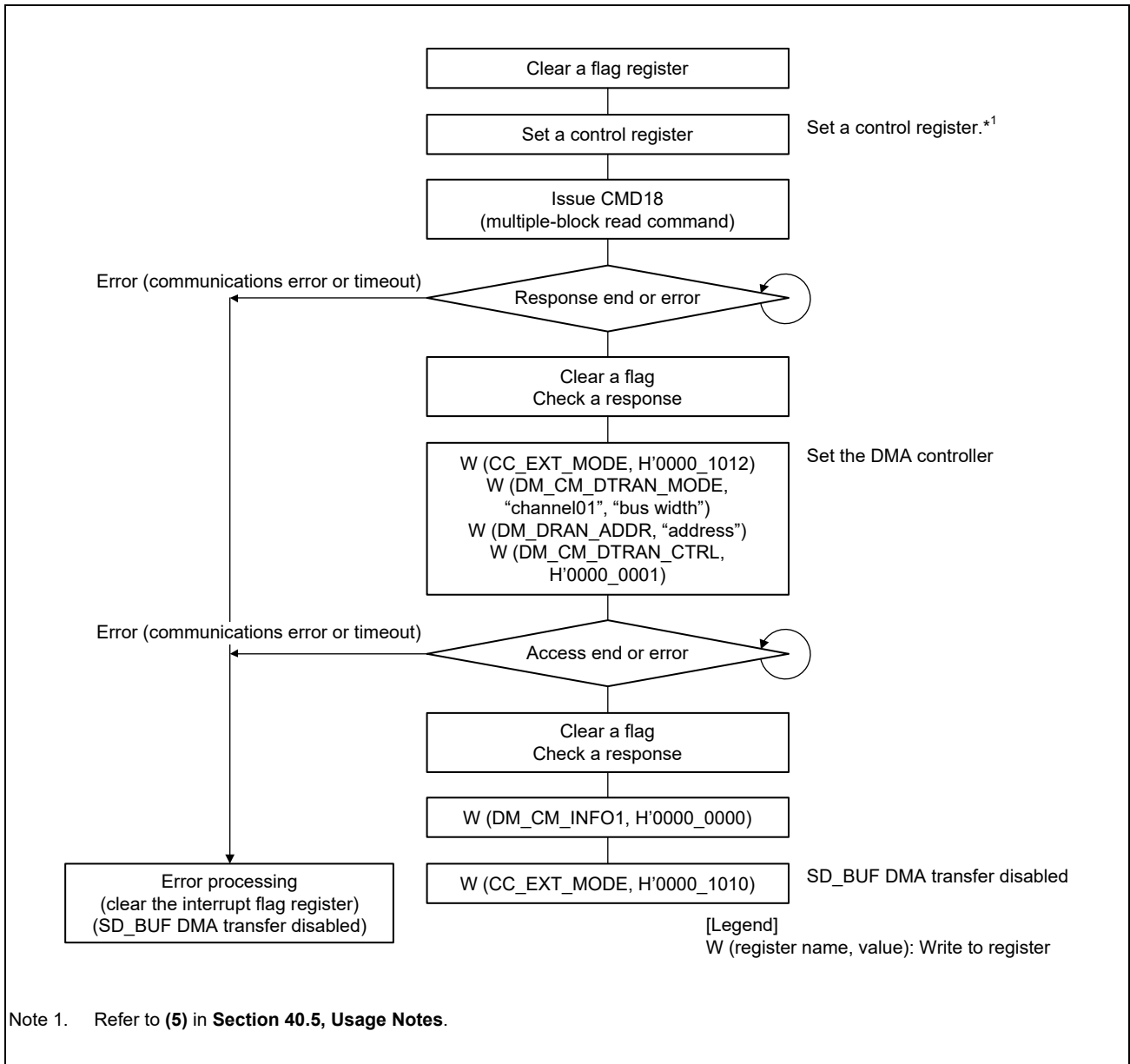

Figure 40.22 SD_BUF DMA Read Flowchart Example

Figure 40.23 shows a flowchart example for SD_BUF DMA write when CMD25 (multiple block write) is issued.

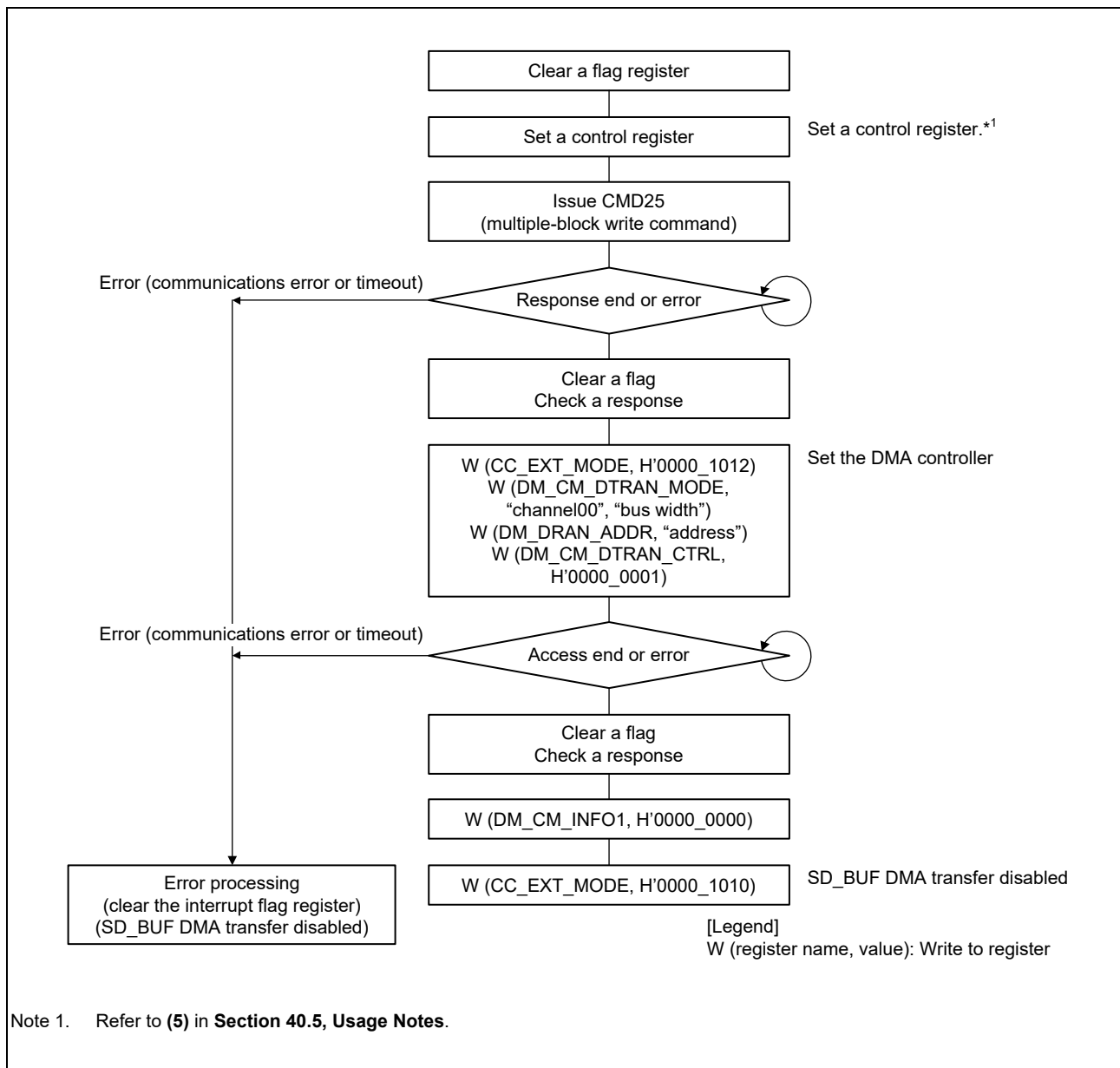

Figure 40.23 SD_BUF DMA Write Flowchart Example

40.4.11 High-Priority Interrupt (without Data Transfer)

(1) Flowchart

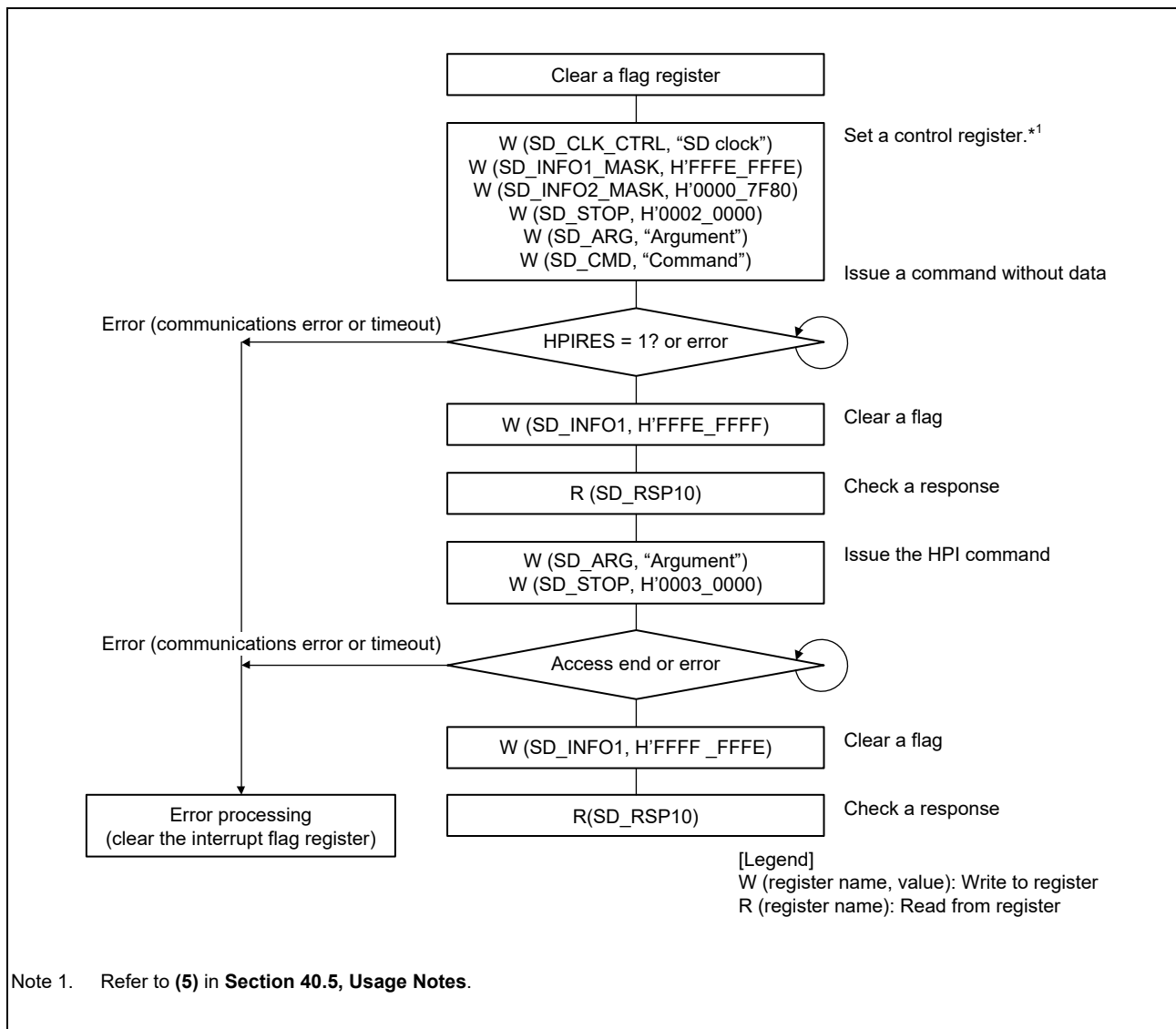

Figure 40.24 Example of the High-Priority Interrupt (without Data Transfer) Flowchart

(2) Operation for High-Priority Interrupt without Data Transfer

The operation of the high-priority interrupt (HPI) without data transfer is described below.

1. Flag register clear
First, clear the bits in the flag register. (SD_INFO1 and SD_INFO2)
2. Control register set
Set the SD clock (SDCLK), HPI enable, interrupt mask, and so on. (SD_CLK_CTRL, SD_INFO1_MASK, and SD_INFO2_MASK)
3. Command issue
Set the CMD Argument in SD_ARG and write to SD_CMD.
Accordingly, CMD is issued, and the operation is started.
4. Flag clear
On receiving the response, the HPIRES bit in SD_INFO1 is set to 1 to generate an interrupt. Clear the HPIRES bit to 0.
5. Read the response from SD_RSP10.
6. HPI command issue
Set the HPI command argument in SD_ARG and set the HPIMODE and HPICMD bits in SD_STOP to 1.
7. Operation complete
When reception of the response to the HPI command is completed and the busy state is released, the INFO0 bit in SD_INFO1 is set to 1 to generate an interrupt. Clear the INFO0 bit to 0 to read the response from SD_RSP10.
This is the end of HPI operation.

Furthermore, perform error processing (clear the interrupt flag register) if an error occurs (a communications error or timeout).

40.4.12 High-Priority Interrupt (at Single Block Write)

(1) Flowchart

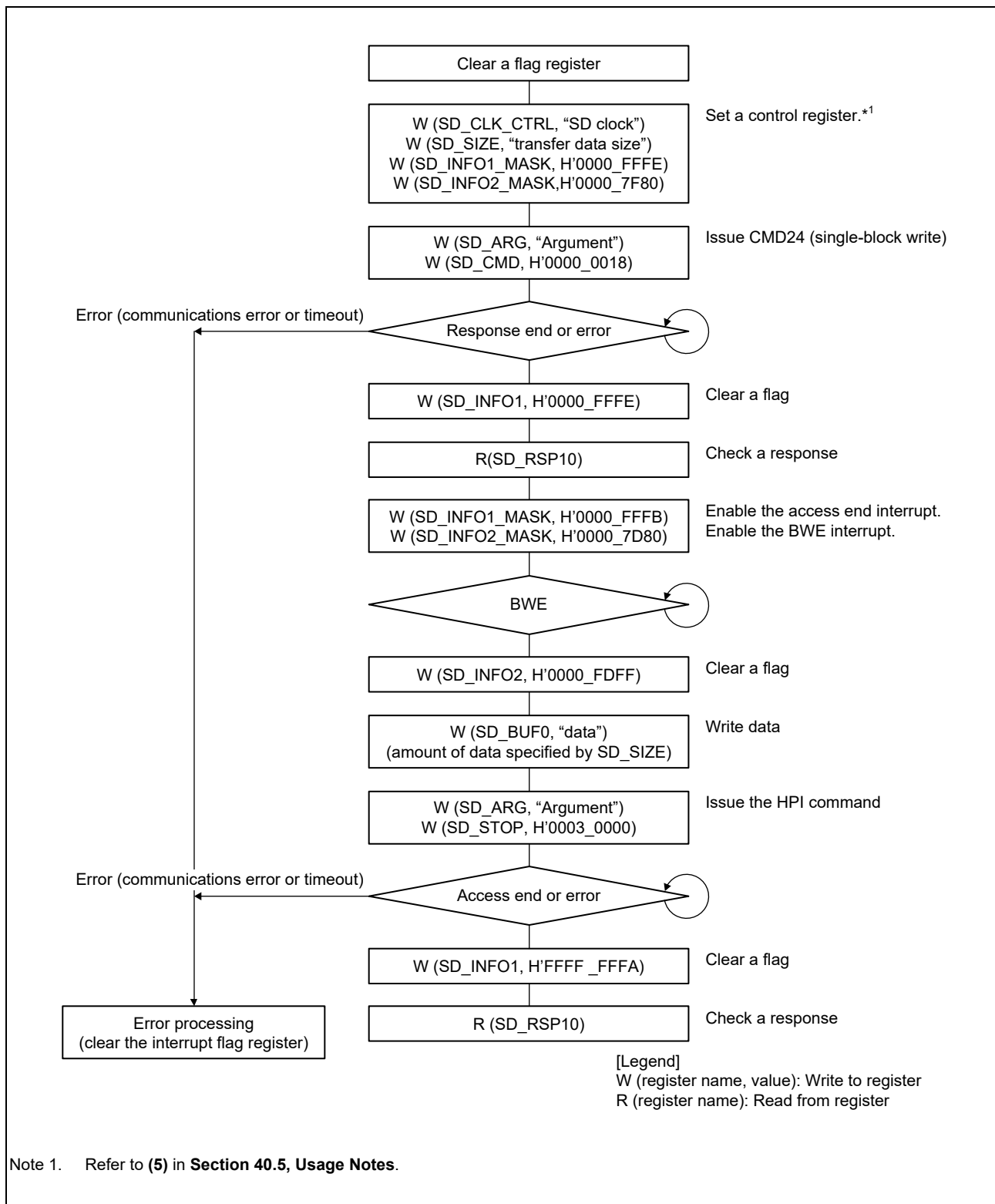

Figure 40.25 Example of the High-Priority Interrupt (at Single Block Write) Flowchart

(2) Operation for HPI at Single Block Write

The operation of HPI at single block write is described below.

1. Flag register clear
First, clear the bits in the flag register. (SD_INFO1 and SD_INFO2)
2. Control register set
Set the SD clock (SDCLK), transfer data size, interrupt mask, and so on. (SD_CLK_CTRL, SD_SIZE, SD_INFO1_MASK, and SD_INFO2_MASK)
3. Command issue (CMD24)
Set CMD24 Argument in SD_ARG and write H'0000 0018 to SD_CMD.
Accordingly, CMD24 is issued, and the single block write operation is started.
4. Response check
On receiving the response, INFO0 (response end) in SD_INFO1 is set to 1 to generate an interrupt. Clear INFO0 to 0 and read the response from SD_RSP10.
If the result of response decoding is an error, the command sequence can be halted by setting the STP bit in SD_STP or the IOABT bit in SDIO_MODE to 1. Furthermore, this causes CMD12 and CMD52 to not be issued. If the command sequence is halted, the INFO2 bit (access end) in SD_INFO1 is set to 1 to generate an interrupt.
5. Data write and data transmit to SD card
Write H'0000 FFFB to SD_INFO1_MASK to enable the access end interrupt. In addition, write H'0000 7D80 to SD_INFO2_MASK to enable the BWE interrupt. When SD_BUF0 is ready for the data to be written, the BWE bit in SD_INFO2 is set to 1 to generate an interrupt. Clear the BWE bit to 0 and write the amount of data specified by SD_SIZE to SD_BUF0. When the data write to SD_BUF0 is completed, data is transmitted to the SD card.
6. HPI command issue
Set the HPI command argument in SD_ARG and set the HPIMODE and HPICMD bits in SD_STOP to 1.
7. Operation complete
When reception of the response to the HPI command is completed and the busy state is released, the INFO2 and INFO0 bits in SD_INFO1 are set to 1 to generate an interrupt. Clear the INFO2 and INFO0 bits to 0 to read the response from SD_RSP10. This is the end of HPI operation.

Furthermore, perform error processing (clear the interrupt flag register) if an error occurs (a communications error or timeout).

40.4.13 High-Priority Interrupt (at Multiple Block Write)

(1) Flowchart

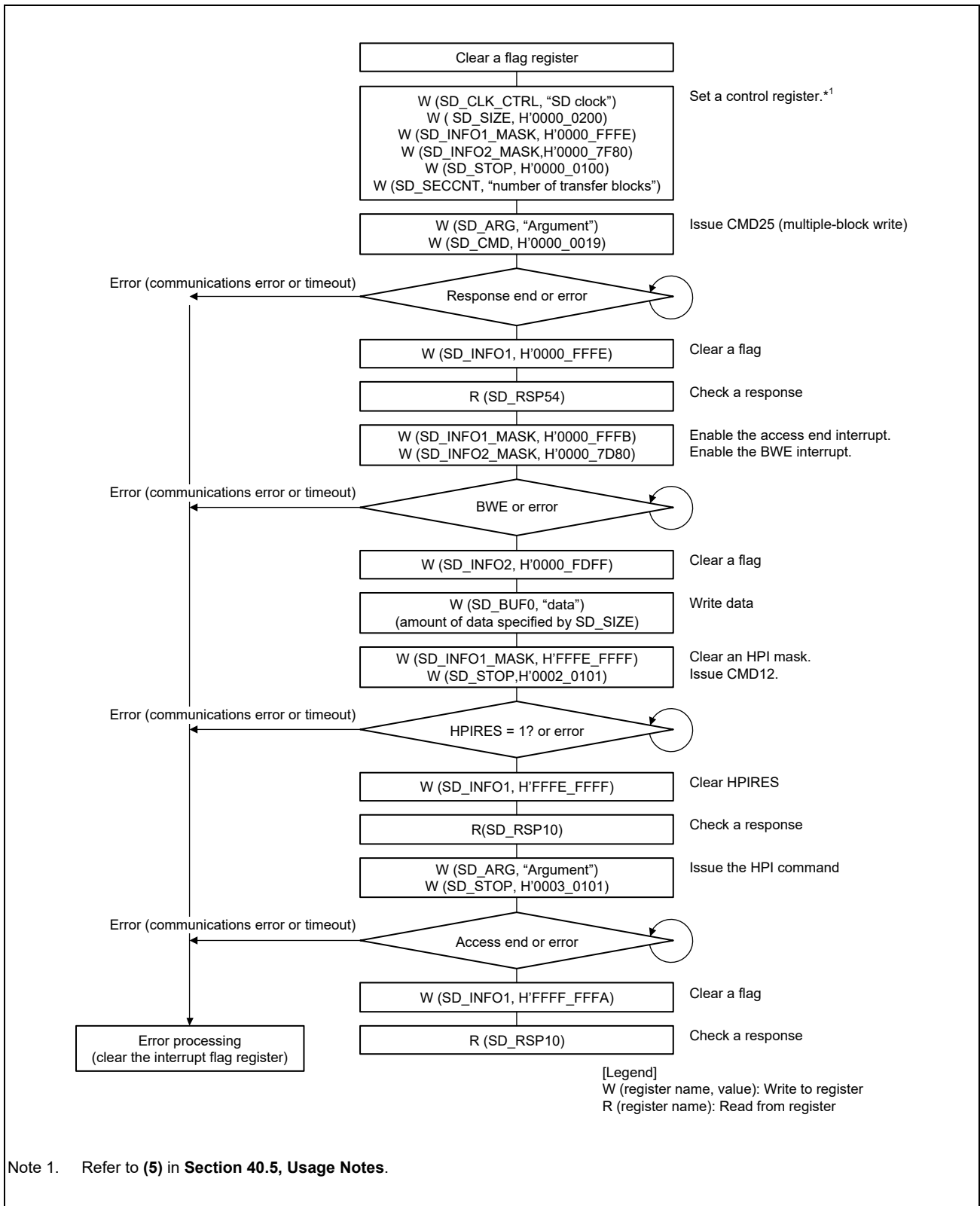

Figure 40.26 Example of the High-Priority Interrupt (at Multiple Block Write) Flowchart (a)

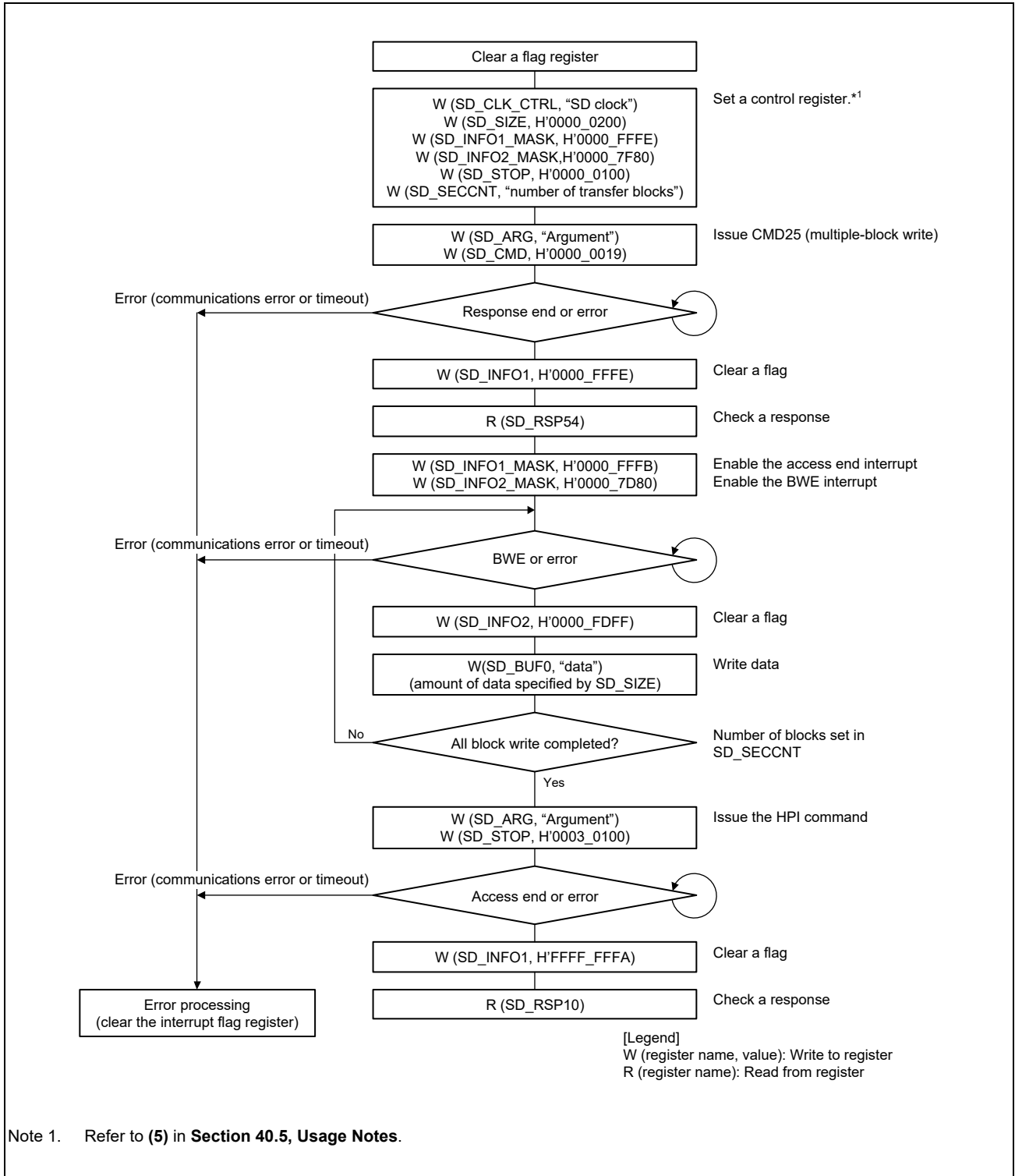

Figure 40.27 Example of the High-Priority Interrupt (at Multiple Block Write) Flowchart (b)

(2) Operation for HPI at Multiple Block Transfer

The operation of HPI at the multiple block write is described below.

(a) When not all the data has been written to SD_BUF

1. Flag register clear
First, clear the bits in the flag register. (SD_INFO1 and SD_INFO2)
2. Control register set
Set the SD clock (SDCLK), transfer data size, interrupt mask, and so on. (SD_CLK_CTRL, SD_SIZE, SD_INFO1_MASK, and SD_INFO2_MASK)
Set the SEC bit in SD_STOP to 1, and set the number of transfer blocks in SD_SECCNT.
3. Command issue (CMD25)
Set CMD25 Argument in SD_ARG and write H'0000 0019 to SD_CMD.
Accordingly, CMD25 is issued, and the multiple block write operation is started.
4. Response check
On receiving the response, INFO0 (response end) in SD_INFO1 is set to 1 to generate an interrupt. Clear INFO0 to 0 and read the response from SD_RSP54.
If the result of response decoding is an error, the command sequence can be halted by setting the STP bit in SD_STP to 1. Setting the STP bit to 1 also causes CMD12 to be issued and the response received. If the command sequence is halted because the access end interrupt has been enabled, an interrupt will be generated by setting of the INFO2 bit (access end) bit in SD_INFO1 to 1 when reception of the response has been completed. Clear the INFO2 bit to 0 and read the response.
5. Data write and data transmit to SD card
Write H'0000 FFFB to SD_INFO1_MASK to enable the access end interrupt. In addition, write H'0000 7D80 to SD_INFO2_MASK to enable the BWE interrupt. When SD_BUF0 is ready for the data to be written, the BWE bit in SD_INFO2 is set to 1 to generate an interrupt. Clear the BWE bit to 0 and write the amount of data specified by SD_SIZE to SD_BUF0. When the data write to SD_BUF0 is completed, data is transmitted to the SD card.
Then, the CRC status and busy state are received from the SD card.
However, a communications error or timeout may be generated if data are being transmitted while writing to SD_BUF0 is in progress.
6. Command issue (CMD12)
Write H'FFFE FFFF to SD_INFO1_MASK to enable the HPIRES interrupt. Write H'0002 0101 to SD_STOP, which causes CMD12 to be issued.
7. Response check
When the response is received, the HPIRES bit in SD_INFO1 is set to 1 to generate an interrupt. Clear the HPIRES bit to 0 to read the response from SD_RSP10.
8. HPI command issue (CMD25)
Set the HPI command argument in SD_ARG and set the HPIMODE and HPICMD bits in SD_STOP to 1.
9. Operation complete
When reception of the response to the HPI command is completed and the busy state is released, the INFO2 and INFO0 bits in SD_INFO1 are set to 1 to generate an interrupt. Clear the INFO2 and INFO0 bits to 0 to read the response from SD_RSP10. This is the end of HPI operation.

Furthermore, perform error processing (clear the interrupt flag register) if an error occurs (a communications error or timeout).

(b) When all the data has been written to SD_BUF

1. Flag register clear
First, clear the bits in the flag register. (SD_INFO1 and SD_INFO2)
2. Control register set
Set the SD clock (SDCLK), transfer data size, interrupt mask, and so on. (SD_CLK_CTRL, SD_SIZE, SD_INFO1_MASK, and SD_INFO2_MASK)
Set the SEC bit in SD_STOP to 1, and set the number of transfer blocks in SD_SECCNT.
3. Command issue (CMD25)
Set CMD25 Argument in SD_ARG and write H'0000 0019 to SD_CMD.
Accordingly, CMD25 is issued, and the multiple block write operation is started.
4. Response check
On receiving the response, INFO0 (response end) in SD_INFO1 is set to 1 to generate an interrupt. Clear INFO0 to 0 and read the response from SD_RSP54.
If the result of response decoding is an error, the command sequence can be halted by setting the STP bit in SD_STP to 1. Setting the STP bit to 1 also causes CMD12 to be issued and the response received. If the command sequence is halted because the access end interrupt has been enabled, an interrupt will be generated by setting of the INFO2 bit (access end) bit in SD_INFO1 to 1 when reception of the response has been completed. Clear the INFO2 bit to 0 and read the response.
5. Data write and data transmit to SD card
Write H'0000 FFFB to SD_INFO1_MASK to enable the access end interrupt. In addition, write H'0000 7D80 to SD_INFO2_MASK to enable the BWE interrupt. When SD_BUF0 is ready for the data to be written, the BWE bit in SD_INFO2 is set to 1 to generate an interrupt. Clear the BWE bit to 0 and write the amount of data specified by SD_SIZE to SD_BUF0. When the data write to SD_BUF0 is completed, data is transmitted to the SD card.
Then, the CRC status and busy state are received from the SD card. Doing this repeats transfer of the number of blocks set in SD_SECCNT.
However, a communications error or timeout may be generated if data are being transmitted while writing to SD_BUF0 is in progress.
6. HPI command issue
Set the HPI command argument in SD_ARG and set the HPIMODE and HPICMD bits in SD_STOP to 1.
7. Operation complete
When reception of the response to the HPI command is completed and the busy state is released, the INFO2 and INFO0 bits in SD_INFO1 are set to 1 to generate an interrupt. Clear the INFO2 and INFO0 bits to 0 to read the response from SD_RSP10. This is the end of HPI operation.

Furthermore, perform error processing (clear the interrupt flag register) if an error occurs (a communications error or timeout).

40.4.14 Example of SD_CMD Register Setting

Table 40.8 lists the example of SD_CMD (SD interface) register setting.

Table 40.8 Example of SD_CMD Register Setting (SD) (1/2)

Type	Command	Example of SD_CMD Register Setting	Remark
CMD	CMD0	H'0000 0000	
	CMD2	H'0000 0002	
	CMD3	H'0000 0003	
	CMD4	H'0000 0004	
	CMD5	H'0000 0705 or H'0000 0005	
	CMD6	H'0000 1C06 or H'0000 0006	
	CMD7	H'0000 0007	When the card is placed in the deselected state, the response timeout flag will be set since there is no response.
	CMD8	H'0000 0408 or H'0000 0008	
	CMD9	H'0000 0009	
	CMD10	H'0000 000A	
	CMD11	H'0000 040B or H'0000 000B	
	CMD12	H'0000 000C	
	CMD13	H'0000 000D	
	CMD15	H'0000 000F	
	CMD16	H'0000 0010	
	CMD17	H'0000 0011	
	CMD18	H'0000 0012	With auto CMD12 enabled (other than in SDR104 mode)
		H'0000 7C12	With auto CMD12 disabled (only in SDR104 mode)
	CMD19	H'0000 1C13 or H'0000 0013	Setting prohibited in DDR50 mode
	CMD20	H'0000 0514 or H'0000 0014	
	CMD23	H'0000 0417 or H'0000 0017	
	CMD24	H'0000 0018	
	CMD25	H'0000 0019	With auto CMD12 enabled (other than in SDR104 mode)
		H'0000 6C19	With auto CMD12 disabled (only in SDR104 mode)
	CMD27	H'0000 001B	
	CMD28	H'0000 001C	
	CMD29	H'0000 001D	
	CMD30	H'0000 001E	
	CMD32	H'0000 0020	
	CMD33	H'0000 0021	
	CMD38	H'0000 0026	
	CMD42	H'0000 002A	
CMD48	H'0000 1C30		
CMD49	H'0000 0C31		
CMD52	H'0000 0434 or H'0000 0034		

Table 40.8 Example of SD_CMD Register Setting (SD) (2/2)

Type	Command	Example of SD_CMD Register Setting	Remark
CMD	CMD53	H'0000 1C35	Single read
		H'0000 0C35	Single write
		H'0000 7C35	Multiple read
		H'0000 6C35	Multiple write
		H'0000 0035	The value on the left can be set irrespective of whether single or multi. However, the CF39 bit in SD_ARG must be set as follows. Read: 0 Write: 1
	CMD55	H'0000 0037	
	CMD56	H'0000 0038	
	CMD58	H'0000 7C3A	
	CMD59	H'0000 6C3B	
	ACMD	ACMD6	H'0000 0046
ACMD13		H'0000 004D	
ACMD22		H'0000 0056	
ACMD23		H'0000 0057	
ACMD41		H'0000 0069	
ACMD42		H'0000 006A	
ACMD51		H'0000 0073	

Table 40.9 lists the example of SD_CMD (MMC interface) register setting.

Table 40.9 Example of SD_CMD Register Setting (MMC)

Type	Command	Example of SD_CMD Register Setting	Remark
CMD	CMD0	H'0000 0000	
	CMD1	H'0000 0701	
	CMD2	H'0000 0002	
	CMD3	H'0000 0003	
	CMD4	H'0000 0004	
	CMD5	H'0000 0505	
	CMD6	H'0000 0506	In the response busy state
		H'0000 0406	Not in the response busy state
	CMD7	H'0000 0007	When the card is placed in the deselected state, the response timeout flag will be set since there is no response.
	CMD8	H'0000 1C08	
	CMD9	H'0000 0009	
	CMD10	H'0000 000A	
	CMD12	H'0000 000C	
	CMD13	H'0000 000D	
	CMD14	H'0000 1C0E	SDIF_MODE must be set to H'0100 (with CRC16 disabled).
	CMD15	H'0000 000F	
	CMD16	H'0000 0010	
	CMD17	H'0000 0011	
	CMD18	H'0000 7C12	Pre-defined
	CMD19	H'0000 0C13	SDIF_MODE must be set to H'0100 (with CRC16 disabled).
	CMD21	H'0000 1C15	
	CMD23	H'0000 0017	
	CMD24	H'0000 0018	
	CMD25	H'0000 6C19	Pre-defined
	CMD26	H'0000 0C1A	
	CMD27	H'0000 001B	
	CMD28	H'0000 001C	
	CMD29	H'0000 001D	
	CMD30	H'0000 001E	
	CMD31	H'0000 1C1F	
	CMD35	H'0000 0423	
	CMD36	H'0000 0424	
CMD38	H'0000 0026		
CMD39	H'0000 0427		
CMD40	H'0000 0428		
CMD42	H'0000 002A		
CMD49	H'0000 0C31		
CMD53	H'0000 7C35		
CMD54	H'0000 6C36		
CMD55	H'0000 0037		
CMD56	H'0000 0038		

40.5 Usage Notes

(1) SD_BUF Illegal Write Access

When writing data to SD_BUF0 after the single block write or multi block write command is issued, the data of the size specified by SD_SIZE must be written to.

If the data of the size which exceeds the size specified by SD_SIZE is written to, the ERR4 bit in SD_INFO2 is set to 1. In addition, the data written to SD_BUF0 may not be transmitted and it causes the SCLKDIVEN bit in SD_INFO2 to hold the value of 0. In such cases, clearing the SDRST bit in SOFT_RST to 0 and then restoring its value to 1 clears the SCLKDIVEN bit to 1.

However, for the single byte (in the case of 16- or 32-bit access) or three bytes (in the case of 32-bit access) when the number of bytes setting in SD_SIZE is odd, or the fraction of bytes when the number of bytes setting in SD_SIZE is even (in the case of 32-bit access), since the portion of dummy data writing is regarded as excess data and ignored, it is not within the scope of the above description (the fraction of bytes: the two bytes that are not in a four-byte unit).

(2) Block Number Limitation for Multiple Block Read

When performing a multiple block read of one or two blocks, depending on the timing with which the response register is read, the response value may not be read properly. This must be avoided by either of the following countermeasures.

- 1) When receiving one or two blocks of data, use single block reading.
- 2) Read the response to CMD18 from SD_RSP54.

<Mechanism of incorrect reading>

Figure 40.28 shows the processing flows of SD/MMC host interface (hardware) operation and software operation when a multiple block read is performed on two blocks. As shown in the incorrect operation of **Figure 40.28**, when an interrupt is generated on reception of the CMD18 response and the timing with which the SD card response register (SD_RSP10) is read by the interrupt is delayed, the data during the CMD12 response reception or the CMD12 response may be read. In the case of a multiple block read of three or more blocks, CMD12 is not issued until the block of data has been read, so this problem does not arise. Furthermore, in the case of a multiple block write, since the CMD25 response is read before the block of data is sent, the problem does not arise.

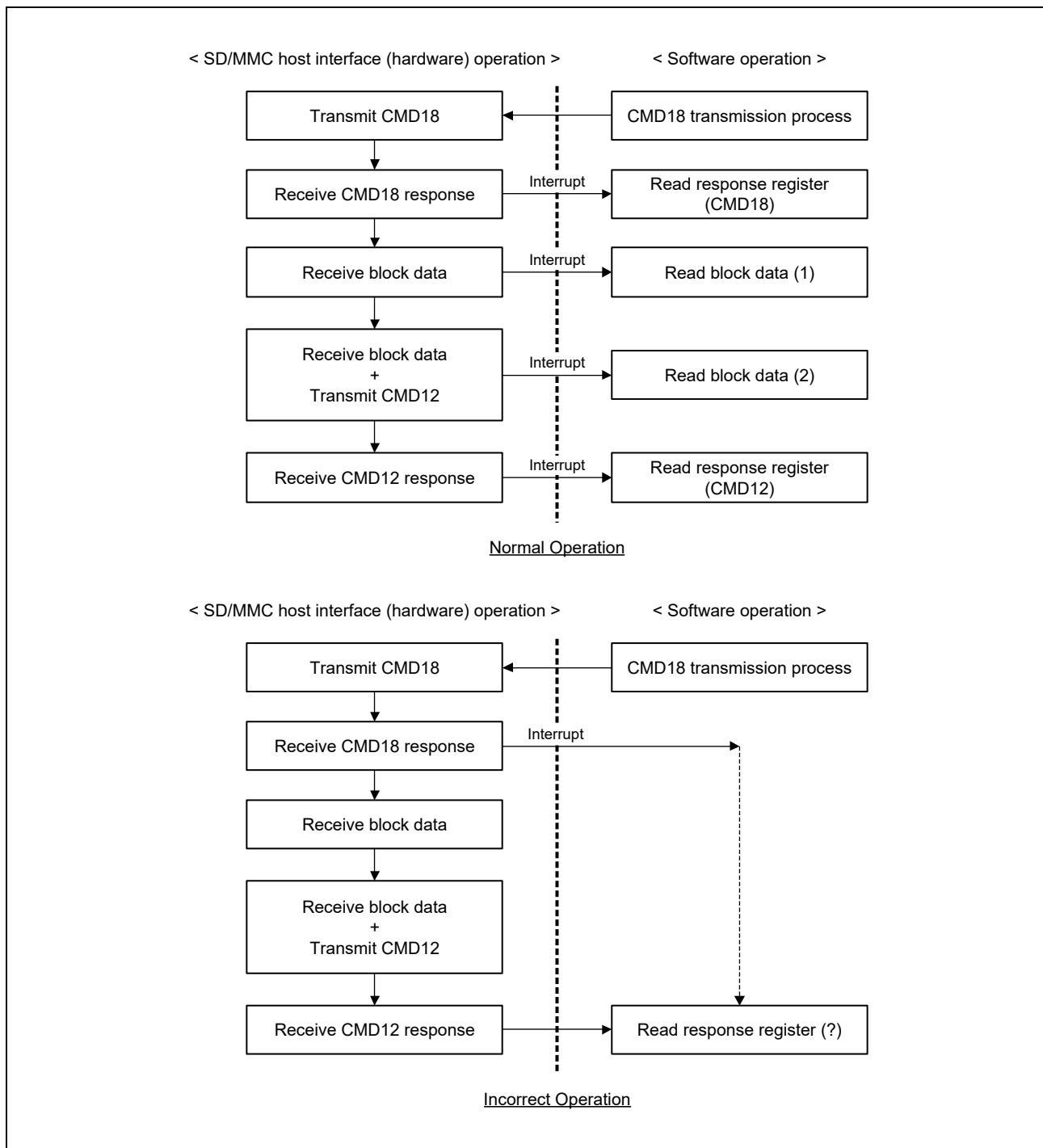

Figure 40.28 Flowcharts for Multiple Block Read Operation (Two Blocks)

(3) Automatic Control of SDCLK Output

In the SD Card standard, 74 cycles of SDCLK must be output before initialization of the card. For this reason, use automatic control of SDCLK output after 74 cycles of SDCLK have been output. Furthermore, if automatic control of SDCLK output was in use, SDCLK output is stopped on completion of the sequence for a communications error or timeout. Thus, in cases where state transitions within the SD card are necessary and so on after completion of the sequence, release automatic control of SDCLK output and restart supply of SDCLK to the SD card.

(4) Control of the C52PUB Setting for Multiple Block Write

If the C52PUB bit in SDIO_MODE is set to 1 during a sequence of multiple block write due to CMD53, CMD52 is not issued until SD_BUF becomes empty. For this reason, set the C52PUB bit after suspending writing to SD_BUF by following the appropriate procedure below.

- When DMA transfer is not in use
 1. Before setting the C52PUB bit, suspend writing to SD_BUF by making the setting in SD_INFO2 to disable BWE interrupts.
 2. Set the C52PUB bit in SDIO_MODE to 1 (so that CMD52 is issued when SD_BUF becomes empty).
 3. After the INFO0 interrupt processing in SD_INFO1 due to the issuing of CMD52 has been completed, restart writing to SD_BUF by making the setting in SD_INFO2 to enable BWE interrupts.
- When DMA transfer is in use
 1. Every time DMA transfer of the value set in SD_SIZE × n blocks (where n = 1, 2, ...) proceeds, suspend writing to SD_BUF by DMA transfer before the C52PUB bit is set.
 2. Set the C52PUB bit in SDIO_MODE to 1 (so that CMD52 is issued when SD_BUF becomes empty).
 3. After the INFO0 interrupt processing in SD_INFO1 due to the issuing of CMD52 has been completed, restart writing to SD_BUF by DMA transfer.

(5) Notes on SD_CLK_CTRL Register Settings

When the SCLKDIVEN bit in SD_INFO2 is 0, SD_CLK_CTRL cannot be written to. Before writing to SD_CLK_CTRL, be sure to check that the SCLKDIVEN bit in SD_INFO2 is 1.

(6) Restrictions on specifications

1. The SDIO suspend/resume is not supported.
2. The SPI bus is not supported.
3. The shared bus and 8-bit SD bus for embedded SDIO are not supported.
4. The stream transfer for MMC cards is not supported.

(7) STP bit setting during multiple block read

During execution of multiple block read with automatic CMD12 execution by setting the SEC bit in SD_STOP to 1, even if the STP bit in SD_STOP is set to 1 to forcibly stop the execution, the command sequence may not stop depending on the timing of setting the STP bit.

To avoid this, when setting the STP bit in SD_STOP to 1 during multiple block transfer, clear the SEC bit in SD_STOP to 0 at the same time. (Even when the SCLKDIVEN bit in SD_INFO2 is 0, change the SEC bit from 1 to 0.)

When the command sequence has not stopped because the SEC bit was not cleared to 0, the command sequence can be stopped by clearing the SDRST bit in SOFT_RST to 0.

When forcibly terminating the CMD53 multiple block transfer through the IOABT bit in SDIO_MODE, be sure to leave the SEC bit in SD_STOP as 1.

40.6 Sampling Clock Controller (SCC)

40.6.1 Features

This module controls a sampling clock (hereafter referred to as the SCC sampling clock) that is used for SD UHS-I/SDR104 and MMC HS200. When this module is used with the LSI, SD UHS-I/SDR104 and MMC HS200 can be supported.

40.6.2 SCC Block Diagram

Figure 40.29 shows a block diagram of the sampling clock controller.

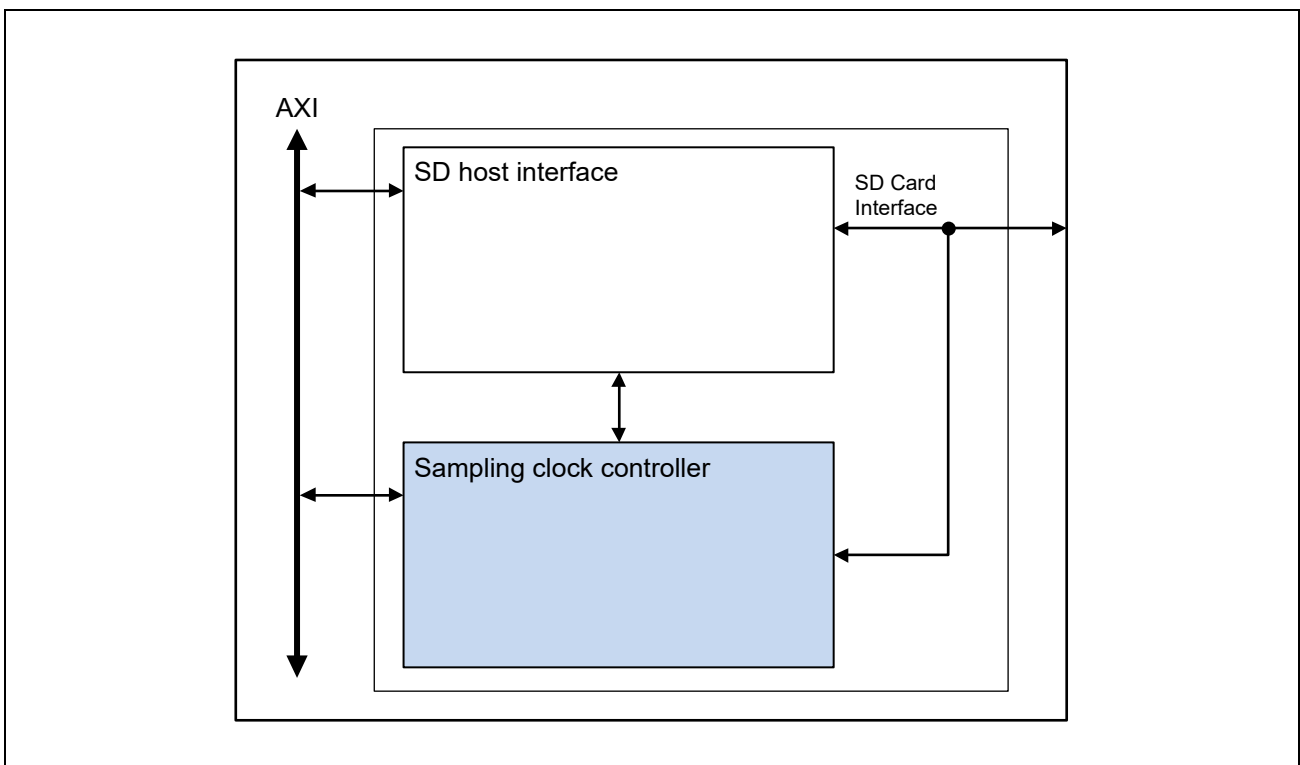

Figure 40.29 Block Diagram of the Sampling Clock Controller

40.6.3 SCC Register Configuration

Table 40.10 shows the SCC registers. Regarding the base address of registers as follows, refer to **Section 40.1.3**.

Channel 0: H'0_11C0_1000 (AX45MP)

Channel 1: H'0_11C1_1000 (AX45MP)

Table 40.10 Register Configuration

Name	Abbreviation	Address [9:0]	Access Size
Initial setting register	SCC_DTCNTL	H'1000	32/64
Sampling clock position setting register	SCC_TAPSET	H'1008	32/64
Hardware adjustment register 1	SCC_DT2FF	H'1010	32/64
Sampling clock selection register	SCC_CKSEL	H'1018	32/64
Sampling clock position correction register	SCC_RVSCNTL	H'1020	32/64
Sampling clock position correction request register	SCC_RVSREQ	H'1028	32/64
Sampling data comparison register	SCC_SMPCMP	H'1030	32/64
Hardware adjustment register 2	SCC_TMPPORT	H'1038	32/64

40.7 SCC Register Descriptions

40.7.1 Initial Setting Register (SCC_DTCNTL)

Bit	Bit Name	Initial Value	R/W	Description
63 to 24	—	All 0	R	Reserved These bits are always read as 0. The write value should always be 0. Operation is not guaranteed if a value other than 0 is written to these bits.
23 to 16	TAPNUM7 to TAPNUM0	H'08	R/W	When bits DIV7 to DIV0 in the SD_CLK_CTRL register are H'FF (1: 1 mode), set these bits to H'08.
15 to 1	—	All 0	R	Reserved These bits are always read as 0. The write value should always be 0. Operation is not guaranteed if a value other than 0 is written to these bits.
0	TAPEN	0	R/W	SCC Sampling Clock Operation Enable 0: SCC sampling clock operation is disabled. 1: SCC sampling clock operation is enabled.

40.7.2 Sampling Clock Position Setting Register (SCC_TAPSET)

Bit	Bit Name	Initial Value	R/W	Description
63 to 8	—	All 0	R	Reserved These bits are always read as 0. The write value should always be 0. Operation is not guaranteed if a value other than 0 is written to these bits.
7 to 0	TAPSET7 to TAPSET0	H'00	R/W	SCC Sampling Clock Position <ul style="list-style-type: none"> Set the tuning result in the range from 0 to TAPNUM-1.

40.7.3 Sampling Clock Selection Register (SCC_CKSEL)

Bit	Bit Name	Initial Value	R/W	Description
63 to 1	—	All 0	R	Reserved These bits are always read as 0. The write value should always be 0. Operation is not guaranteed if a value other than 0 is written to these bits.
0	DTSEL	0	R/W	Sampling Clock Selection 0: An SCC sampling clock is not used (for other than SDR104 and HS200). 1: An SCC sampling clock is used (for SDR104 or HS200). <ul style="list-style-type: none"> For SDR104 or HS200, set DTSEL to 1. DIV[7:0] in the SD_CLK_CTRL register to H'FF (1:1 mode). When this bit is switched, stop the SD clock output from the SD/MMC host interface (set SCLKEN in SD_CLK_CTRL to 0).

40.7.4 Sampling Clock Position Correction Register (SCC_RVSCNTL)

Bit	Bit Name	Initial Value	R/W	Description
63 to 16	—	All 0	R	Reserved These bits are always read as 0. The write value should always be 0. Operation is not guaranteed if a value other than 0 is written to these bits.
15 to 8	TAPSEL7 to TAPSEL0	H'00	R	SCC Sampling Clock Position Display <ul style="list-style-type: none"> Displays the SCC sampling clock position selected by hardware. After RVSEN has been set to 1, the value may differ from that of TAPSET.
7 to 2	—	All 0	R	Reserved These bits are always read as 0. The write value should always be 0. Operation is not guaranteed if a value other than 0 is written to these bits.
1	RVSW	0	R/W	This bit is read as 0. The write value should be 1.
0	RVSEN	0	R/W	SCC Sampling Clock Position Correction Enable <ul style="list-style-type: none"> 0: SCC sampling clock position correction is disabled. 1: SCC sampling clock position correction is enabled. When RVSEN is set to 1 after tuning has been performed, this module corrects the SCC sampling clock position each time of a command sequence of the SD/MMC host interface. However, when RVSEERR is 1, this module does not correct the SCC sampling clock position. While tuning is being performed, set RVSEN to 0.

40.7.5 Sampling Clock Position Correction Request Register (SCC_RVSREQ)

Bit	Bit Name	Initial Value	R/W	Description
63 to 3	—	All 0	R	Reserved These bits are always read as 0. The write value should always be 0. Operation is not guaranteed if a value other than 0 is written to these bits.
2	RVSEERR	0	R/W	SCC Sampling Clock Position Correction Error <ul style="list-style-type: none"> 0: There is no correction error. 1: There is a correction error. If this bit is set to 1 after a command sequence, write 0 to this bit and perform tuning again. Ignore this bit while tuning is being performed. Writing 1 to this bit is disabled and writing 0 to this bit is only enabled.
1	REQTAPUP	0	R/W	SCC Sampling Clock Position Positive Direction Correction Request <ul style="list-style-type: none"> 0: There is no correction request. 1: There is a correction request. If this bit is set to 1 after a command sequence, write 0 to this bit and rewrite TAPSET in the positive direction (when TAPSEL = TAPNUM-1, set 0 to TAPSET). When RVSEN is 1, this bit is disabled (this bit is not set to 1). Writing 1 to this bit is disabled and writing 0 to this bit is only enabled.
0	REQTAPDOWN	0	R/W	SCC Sampling Clock Position Negative Direction Correction Request <ul style="list-style-type: none"> 0: There is no correction request. 1: There is a correction request. If this bit is set to 1 after a command sequence, write 0 to this bit and rewrite TAPSET in the negative direction (when TAPSEL = 0, set TAPNUM-1 to TAPSET). When RVSEN is 1, this bit is disabled (this bit is not set to 1). Writing 1 to this bit is disabled and writing 0 to this bit is only enabled.

40.7.6 Hardware Adjustment Register 1 (SCC_DT2FF)

This register makes a setting that SD_DATA, which has been fetched by the sampling clock at each TAP position, is used in the appropriate timing.

Bit	Bit Name	Initial Value	R/W	Description
63 to 16	—	All 0	R	Reserved These bits are always read as 0. The write value should always be 0. Operation is not guaranteed if a value other than 0 is written to these bits.
15 to 8	DT2NE	H'03	R/W	Hardware Adjustment 2 This is a setting register for adjusting the timing inside the IP when using Tuning. When using Tuning, set H'02 to this bit, make the setting before setting 1 in SCC_CKSEL [0].DTSEL.
7 to 0	DT2NS	H'00	R/W	Hardware Adjustment 1 This is a setting register for adjusting the timing inside the IP when using Tuning. When using Tuning, set H'07 to this bit., make the setting before setting 1 in SCC_CKSEL [0].DTSEL.

40.7.7 Sampling data comparison register (SCC_SMPCMP)

Data comparison register indicates the result of the comparison of the sampling data. The subject of the comparison is the before and the behind TAP.

Bit	Bit Name	Initial Value	R/W	Description
63 to 25	—	All 0	R	Reserved These bits are always read as 0. The write value should always be 0. Operation is not guaranteed if a value other than 0 is written to these bits.
24 to 16	CMPNGU	All 0	R/W	Comparison of sampling data with the previous TAP Clock. Bit 16-23 is the comparison result of data 0-7. Bit 24 is the comparison result of CMD. 0: Match 1: Mismatch < Clear conditions.> The start of the command sequence Write to SCC_TAPSET register
15 to 9	—	All 0	R	Reserved These bits are always read as 0. The write value should always be 0. Operation is not guaranteed if a value other than 0 is written to these bits.
8 to 0	CMPNGD	All 0	R/W	Comparison of sampling data with the after TAP Clock. Bit 0-7 is the comparison result of data 0-7. Bit 8 is the comparison result of CMD. 0: Match 1: Mismatch < Clear conditions.> The start of the command sequence Write to SCC_TAPSET register

40.7.8 Hardware adjustment register 2 (SCC_TMPPORT)

This register makes a setting that SD_DATA, which has been fetched by the sampling clock at each TAP position, is used in the appropriate timing.

Bit	Bit Name	Initial Value	R/W	Description
63 to 16	—	All 0	R	Reserved These bits are always read as 0. The write value should always be 0. Operation is not guaranteed if a value other than 0 is written to these bits.
15 to 0	TMPOUT	H'0000	R/W	Hardware adjustment 3 When using the delay tuning mechanism, set the following values. When TAPNUM = 8, set H'0000 to these bits. When operating with other than SDR104 / HS200, this register adjusts the clock delay of the Flip Flop that latches the received data from the outside of the chip. For this product, set H'0000 when transferring at 3.3V, and set H'0001 when transferring at 1.8V.

40.8 Usage Example of SCC

40.8.1 Tuning

SCC is tuned by using operation of single-block reading.

As shown in **Figure 40.30**, check whether the single-block read command normally ends when the sampling clock position is changed from 0 to TAPNUM-1 and save the result. After checking, confirm that there exists the range which has three or more continuous normal ends (OK). Then, the median value within the continuous range is determined as the final adjustment value.

Figure 40.31 and **Table 40.11** show the detailed tuning flow and the method how to select the sampling clock position (example when TAPNUM = 8).

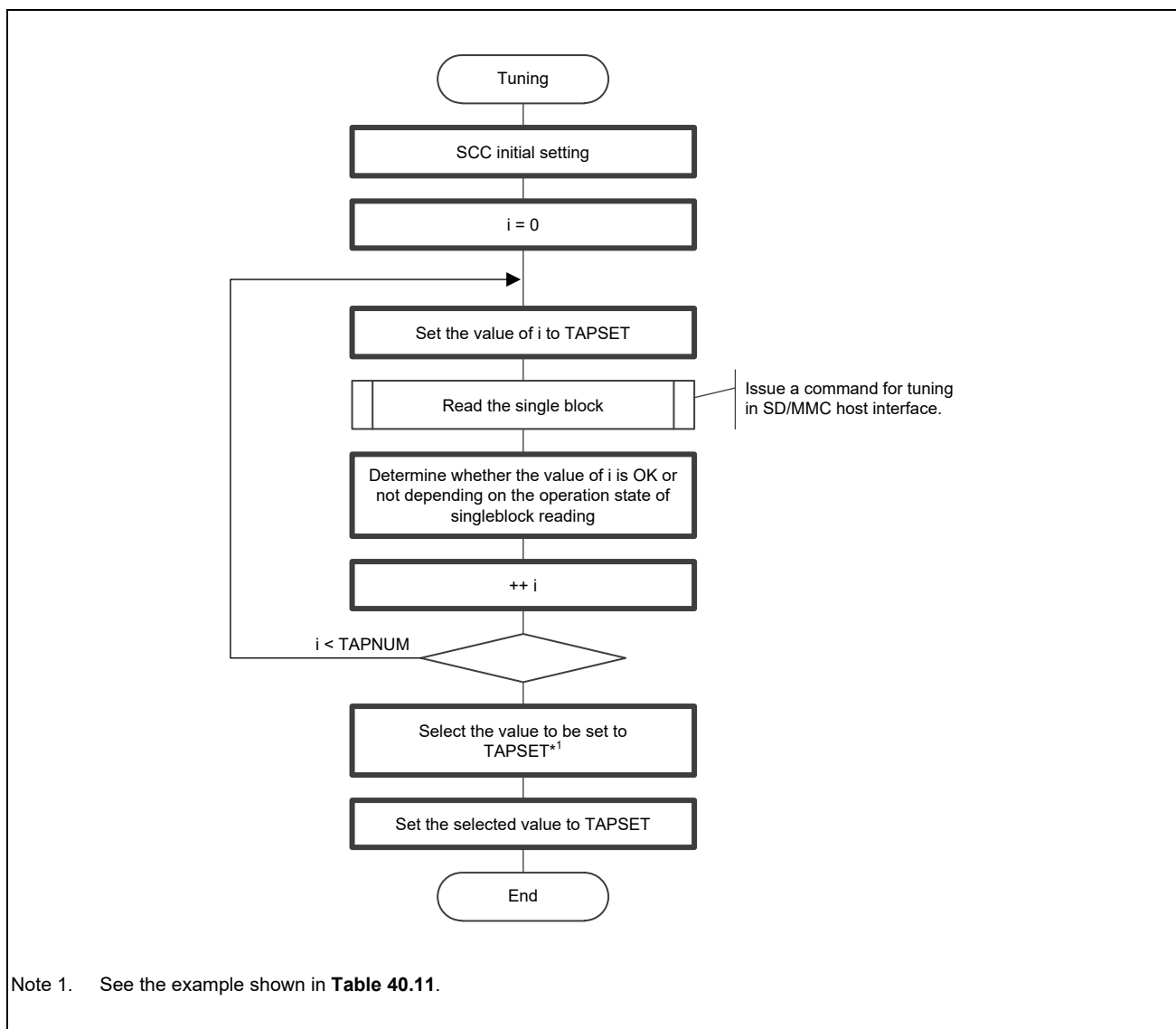
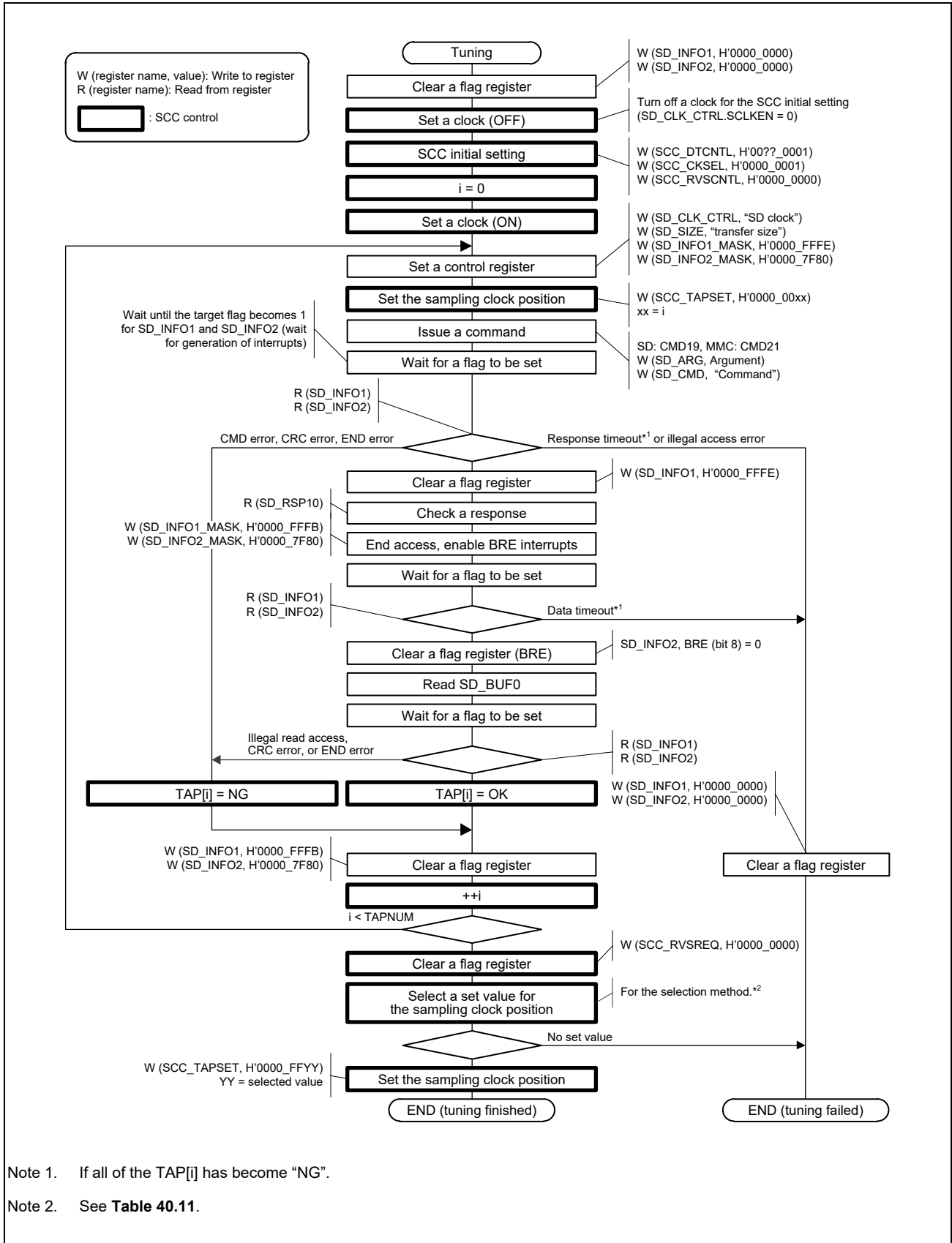

Figure 40.30 Example of Tuning Flow (Outline)



Note 1. If all of the TAP[i] has become "NG".

Note 2. See Table 40.11.

Figure 40.31 Example of Tuning Flow (Detailed)

Table 40.11 Example of the Method How to Select the Sampling Clock Position (when TAPNUM = 8)

Item	i	Case 1	Case 2	Case 3	Case 4	Case 5*1
TAP[i]	0	NG	OK	NG	OK	OK
	1	OK	OK	NG	NG	OK
	2	OK	NG	OK	NG	OK
	3	OK(←)	NG	OK	NG	OK
	4	OK	NG	NG	NG	OK
	5	OK	OK	NG	OK	OK
	6	NG	OK	NG	OK(←)	OK
Max. value→	7	NG	OK(←)	NG	OK	OK
	(0)	NG	OK	NG	OK	OK
	(1)	OK	OK	NG	NG	OK
	(2)	OK	NG	OK	NG	OK
	(3)	OK	NG	OK	NG	OK
	(4)	OK	NG	NG	NG	OK
	(5)	OK	OK	NG	OK	OK
	(6)	NG	OK	NG	OK	OK
(7)	NG	OK	NG	OK	OK	
Selected value		i = 3	i = 7	Fail	i = 6 or 7	i = 0 to 7

Remarks: (←): Example of selection, (x): repeated display of index x of TAP[x]

(a) The sampling clock position is selected by considering a margin in the range which has three or more continuous 'TAP[i] = OK'.

(b) The sampling clock position is repeated from 0 after the maximum value (TAPNUM-1). In case 2 above, that position is continued in the order of 5→6→7→0→1.

Note 1. If all of the TAP [i] is OK, the sampling clock position is selected by identifying the change point of data. Change point of the data can be found in the value of SCC_SMPCMP register. Usage example is **Section 40.8.3, Change point of the input data.**

40.8.2 Sampling Clock Position Correction after Tuning

After tuning, correction of the sampling clock position may be required when a command is issued.

There are manual and automatic correction methods. After a command sequence, if the CMD, CRC, END error or time out occurs or the correction error occurs, tuning will be performed again. The following shows examples of manual and automatic correction methods.

(1) Manual correction of the sampling clock position

Figure 40.32 shows the flow of manual correction of the sampling clock position. Table 40.12 shows set values determined when correction is required (when TAPNUM = 8).

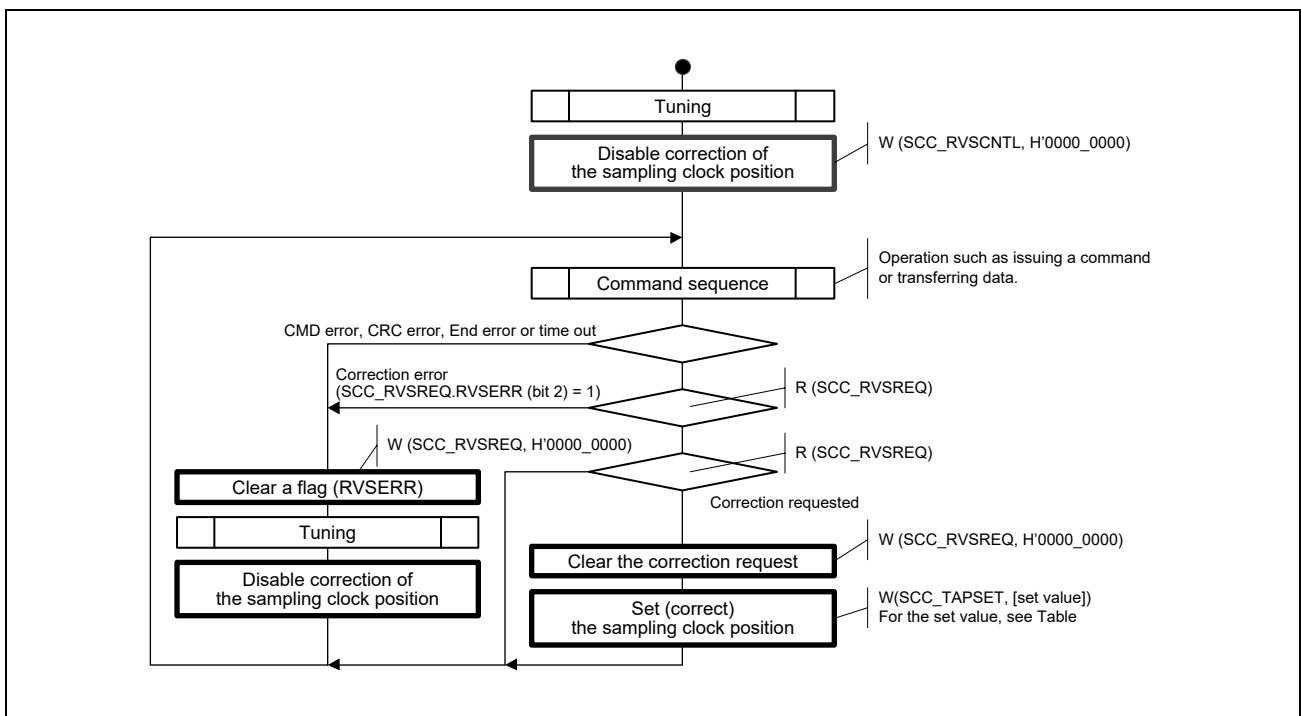

Figure 40.32 Flow of Manual Correction of the Sampling Clock Position (Example)

Table 40.12 Set Values for TAPSET when Correction is Required (when TAPNUM = 8)

No.	Current value of TAPSET	Value set to TAPSET when REQTAPUP = 1	Value set to TAPSET when REQTAPDWN = 1
1	0	1	7
2	1	2	0
3	2	3	1
4	3	4	2
5	4	5	3
6	5	6	4
7	6	7	5
8	7	0	6

Note: As is the case in the tuning selection method, the sampling clock position is 0 after the maximum value (TAPNUM-1).

(2) Automatic correction of the sampling clock position

Figure 40.33 shows the flow of automatic correction of the sampling clock position.

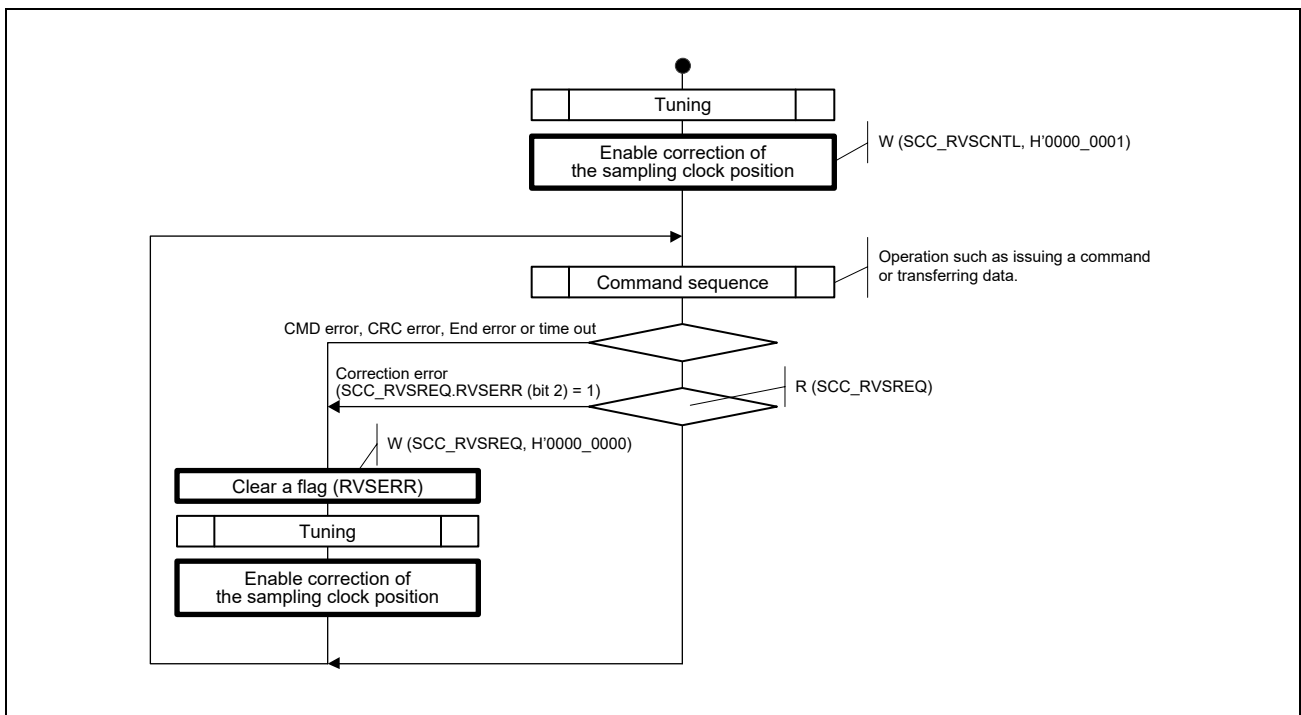

Figure 40.33 Flow of Automatic Correction of the Sampling Clock Position (Example)

40.8.3 Change point of the input data

Tuning captures the data by the TAP clock selected. However, also captures the data by the previous TAP clock and the behind the TAP clock at the same time. This result is reflected in the sampling data comparison register (SCC_SMPCMP). Point of mismatch before and after the selected TAP clock is the changing point of the data. In this example, it is desirable to set as TAP6 or TAP7.

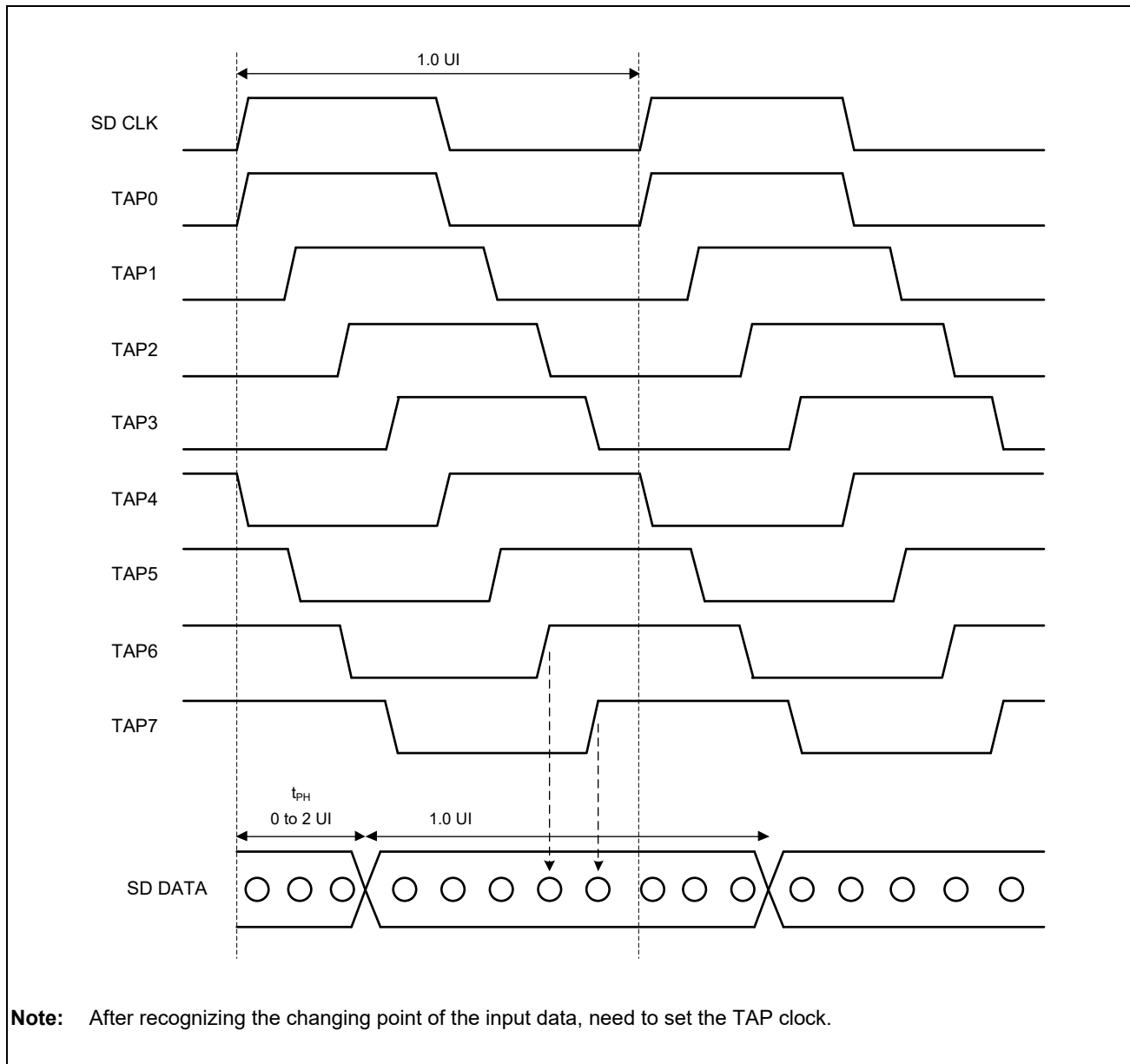

Figure 40.34 Example, All taps is OK.

Figure 40.34 shows change point of data between TAP2 and TAP3. Change point of the data can be confirmed by sampling data comparison register (SCC_SMPCMP). When the tuning of TAP2 or TAP3, CMPNGU bit of sampling data comparison register indicates a mismatch. As the width of the input data is 1 (UI), select TAP6 or TAP7 which is the median of next TAP3 from TAP3.

41. General Purpose Input Output Port (GPIO)

This LSI can use up to 114 general-purpose I/O ports.

Each port of the general-purpose I/O port is multiplexed with the terminal of the peripheral function, and either the general-purpose I/O port function or the peripheral function can be selected by setting the register.

41.1 Features

41.1.1 General Purpose Input Output Port (GPIO)

General-purpose input/output ports (GPIOs) provide general-purpose ports that can be configured as inputs or outputs.

When set as an output, it can be written to an internal register to control the state driven by the output pin. When set as an input, you can read the state of the input by reading the state of the internal registers. You can also generate interrupts using the GPIO input pin.

- GPIO Output Control (Port Register [Pn])
- GPIO Input, Output Enable (Port Mode Register [PMn])
- GPIO Input Monitor (Port Input Register [PINn])
- Interrupt used the GPIO input (Interrupt Enable Control Register[ISEL])

Also, it able to control the following on some ports

- IO voltage mode control for each port
- Buffer drive ability control for each port
- Slew Rate Switching for each port
- Pull Up / Pull down Switching for each port
- Digital noise filter control for each port

41.1.2 Port Function Control

Switching of each port function can be controlled by the following register settings.

- GPIO function and peripheral function selection (Port Mode Control Register[PMcN])
- Selection of each peripheral function (Port Function Control Register[PFCm]) [Function0 to 7]

NOTE

Please refer to another file for the pin function for the peripheral functions that can be selected.

Please refer to above excel file for the“Pin function list” described in each chapter.

Do not select the same peripheral function for multiple different external terminals.

41.1.3 Special Purpose Port Function Control

The settings of the following specific ports can be controlled by registers.

- IO voltage mode control for each port
- Buffer drive ability control for each port
- Slew Rate Switching for each port
- Digital noise filter control for each port
- Ether MII / RGMII mode control

The specific ports shown below are targeted.

- Target Functions: Ether ch0/ch1, SDHI ch0/ch1, QSPI, RIIC
- Target Signals: NMI, TMS/SWDIO, TDO, WDTOVF_PERROUT#, AUDIO_CLK1, AUDIO_CLK2

41.1.4 General Purpose Input Output Port Configuration

The configuration of the general-purpose I/O port is shown in **Figure 41.1** to **Figure 41.5**.

In addition, the configuration of the multiplexed Ether ch0 / ch1 is also included in the configuration diagram of the general-purpose I/O port.

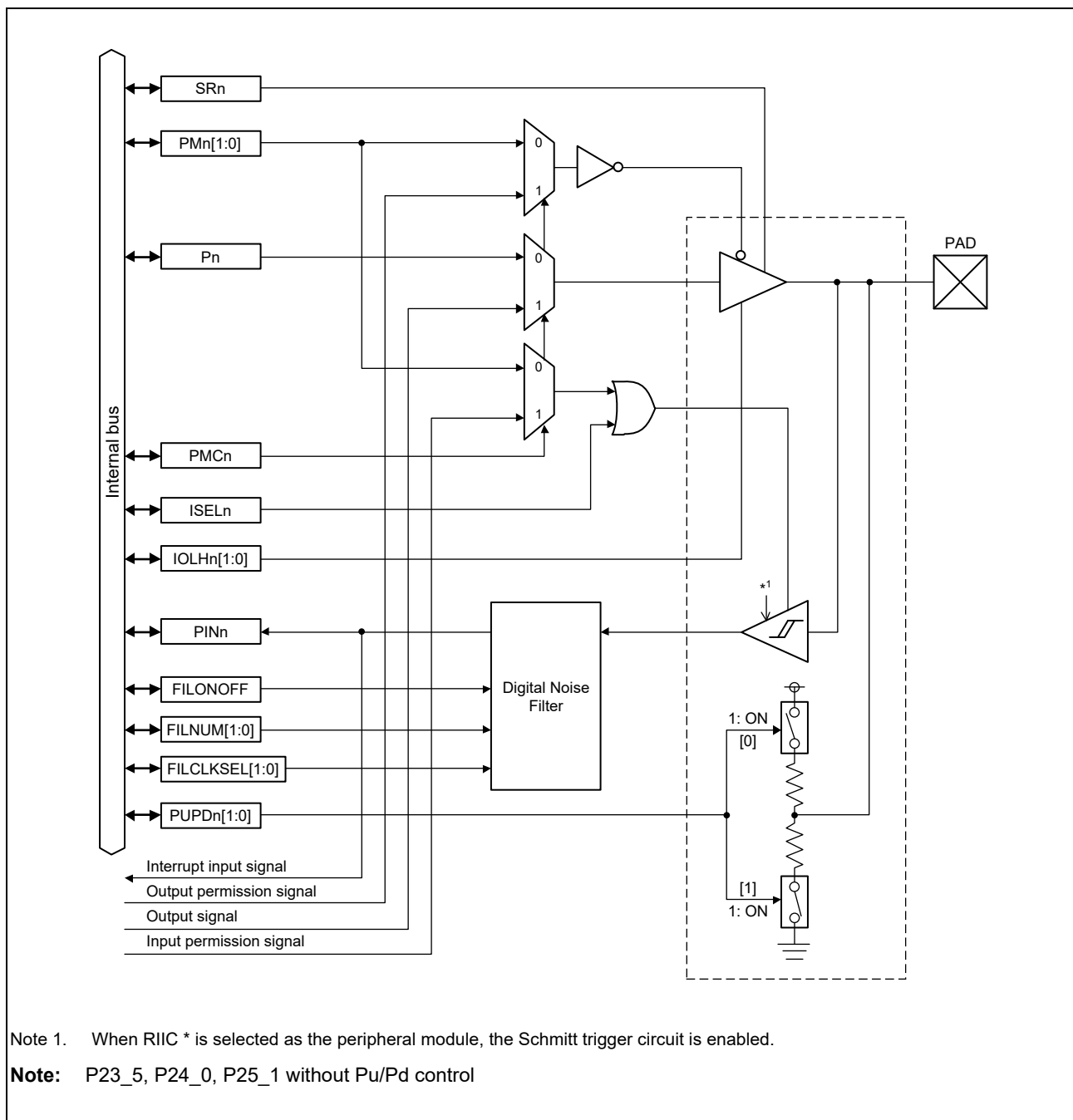

Figure 41.1 P0_0 to P0_3, P5_0 to P6_4, P11_0 to P18_5, P19_1 to P28_5 (Multiplexed peripheral functions)

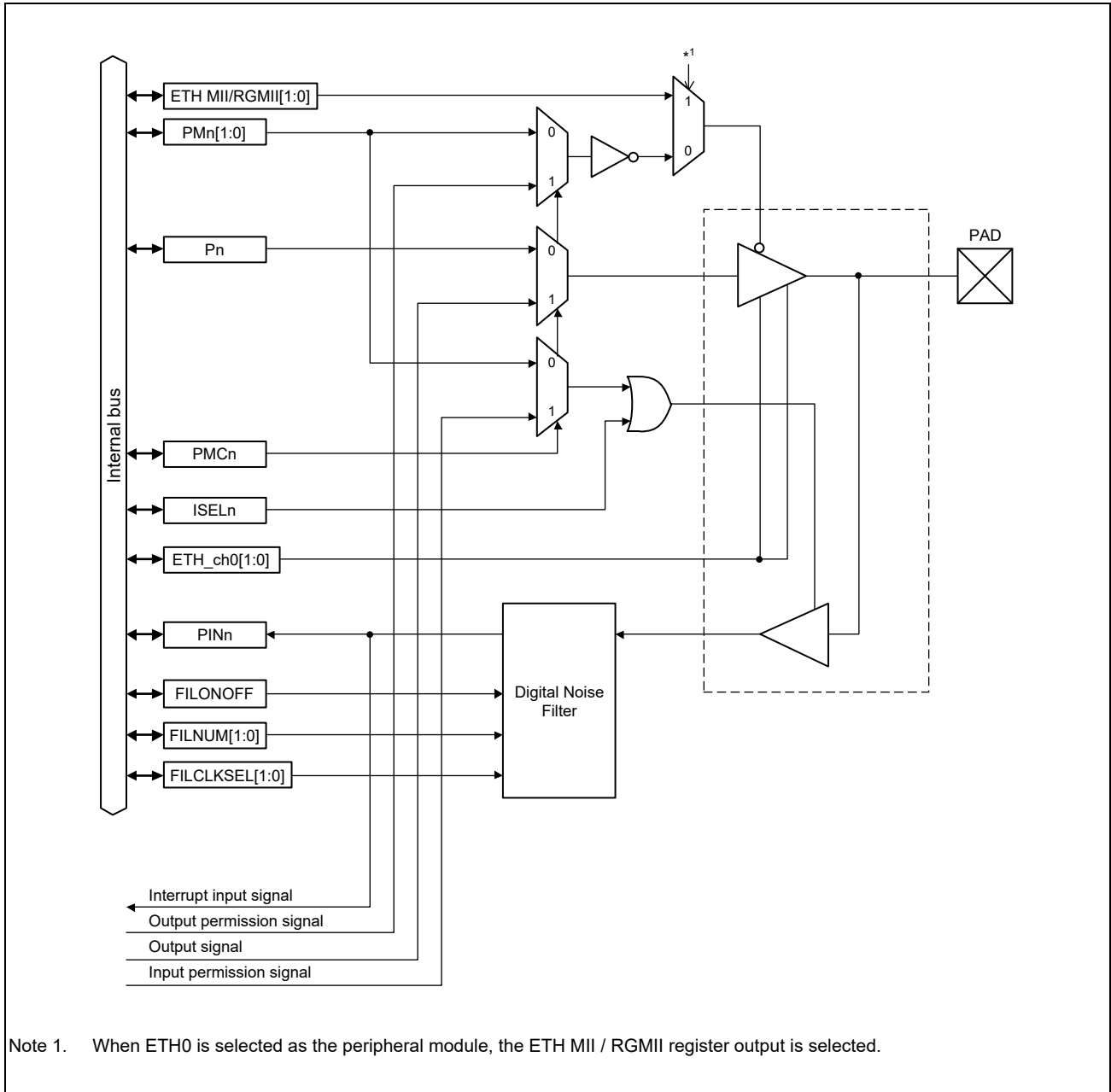

Figure 41.2 P1_0 (Multiplexed Ether ch0)

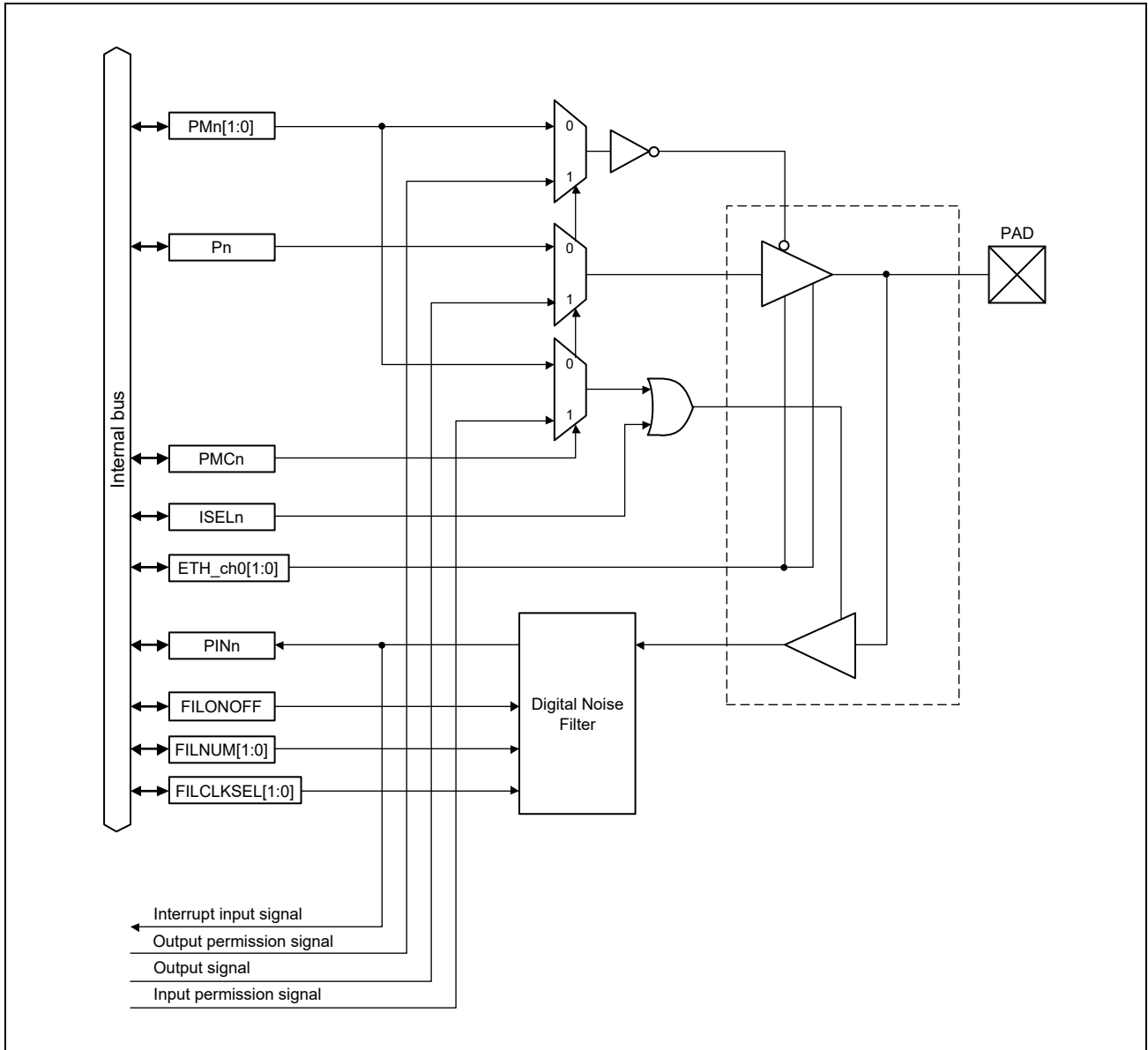

Figure 41.3 P1_1 to P4_5 (Multiplexed Ether ch0)

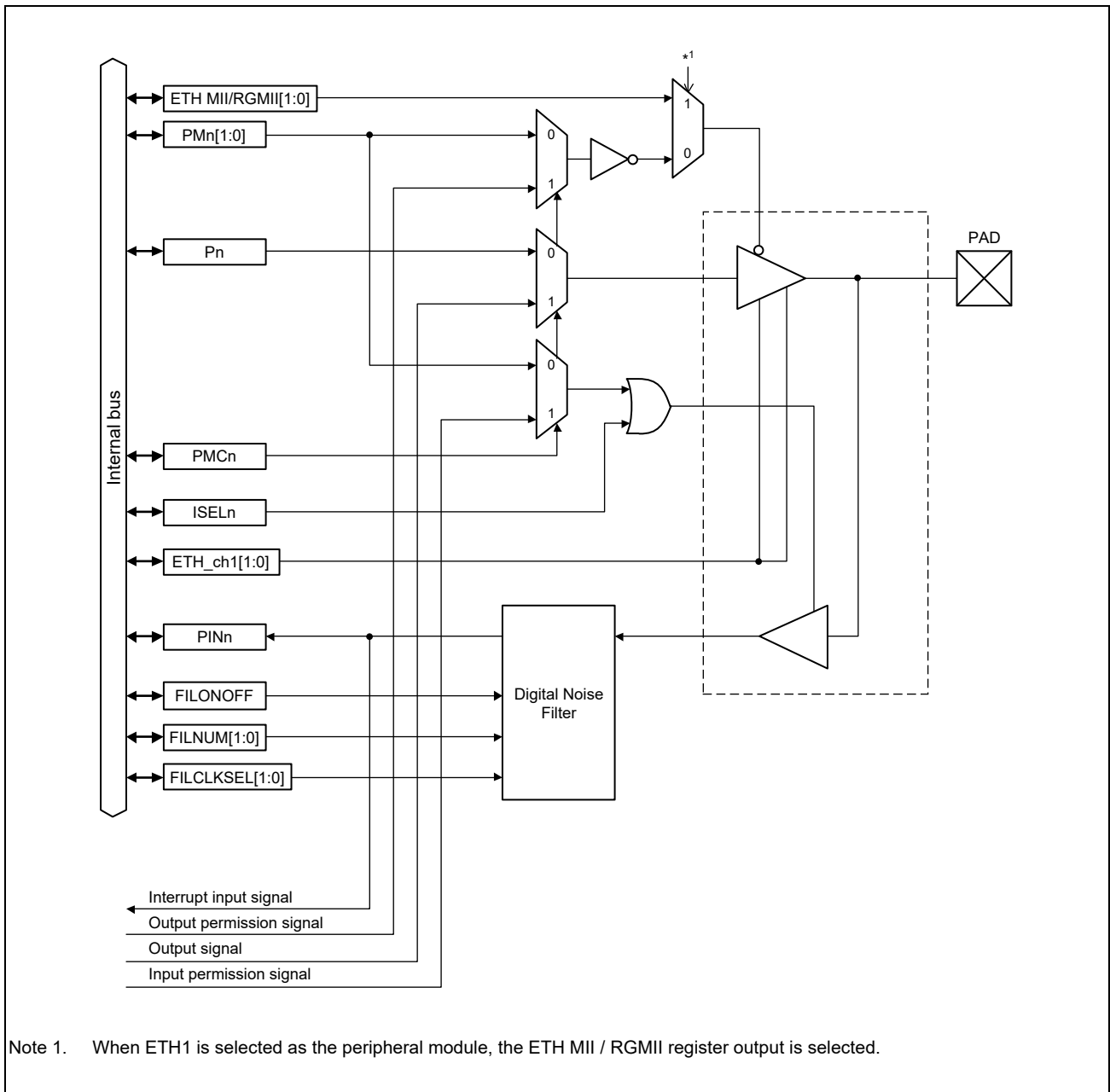

Figure 41.4 P7_0 (Multiplexed Ether ch1)

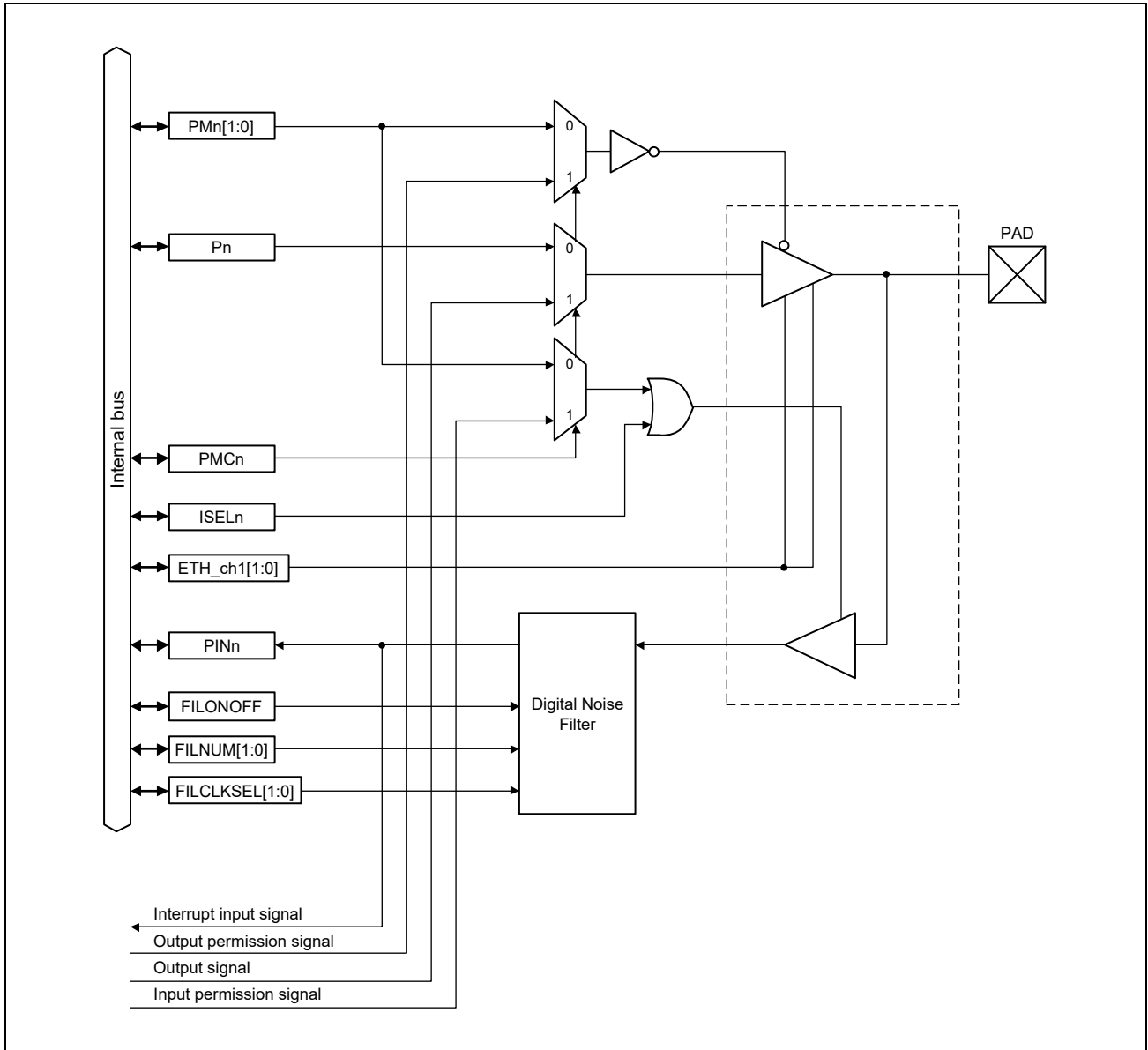

Figure 41.5 P7_1 to P10_4 (Multiplexed Ether ch1)

41.1.5 Special purpose port Configuration

The functions and the signal of configurations shown below are shown in **Figure 41.6** to **Figure 41.13**.

- Target Functions: SDHI ch0, SDHI ch1, QSPI, RIIC
- Target Signals: NMI, TMS/SWDIO, TDO, WDTOVF_PERROUT#, AUDIO_CLK1, AUDIO_CLK2

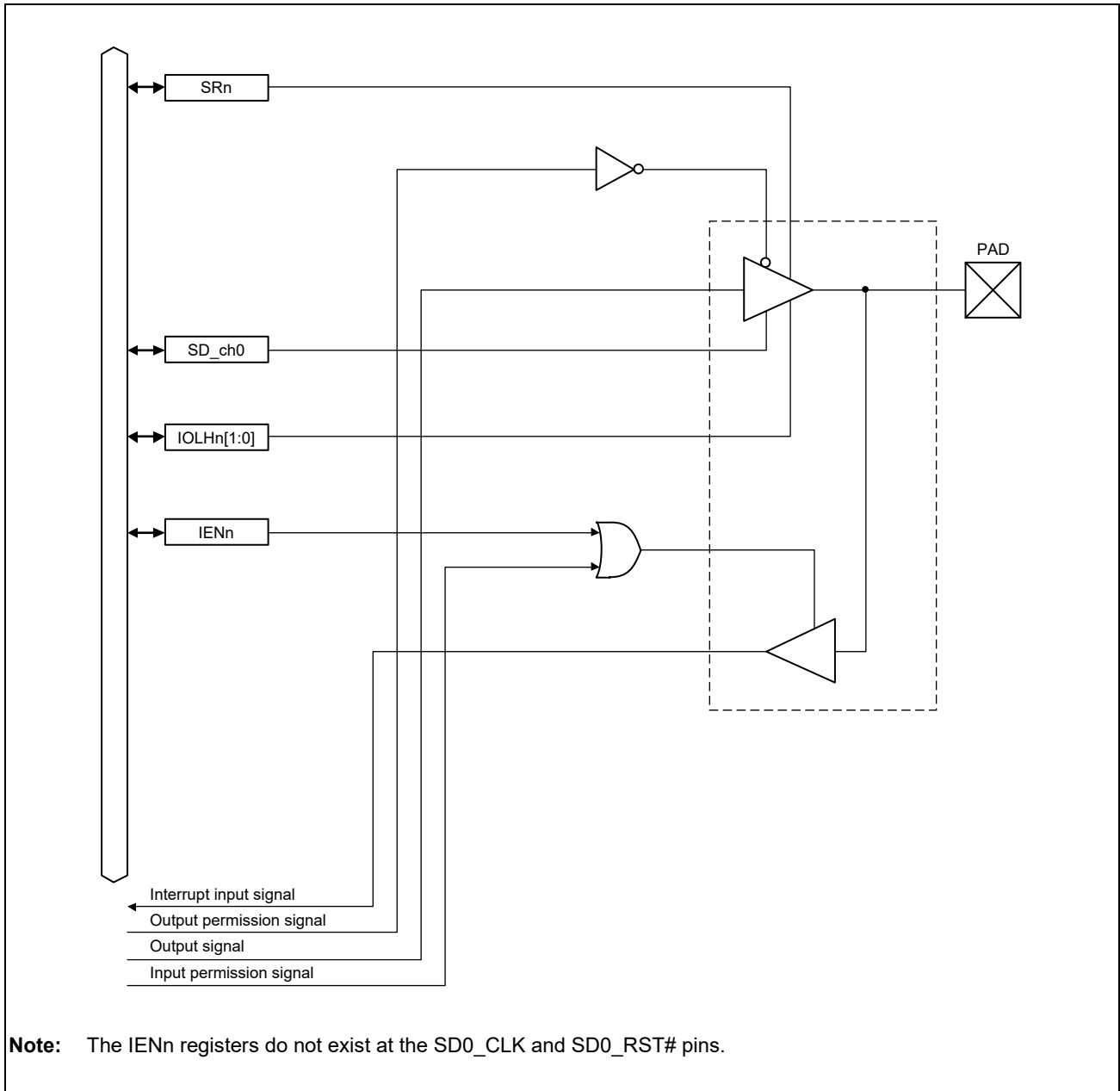

Figure 41.6 SDHI ch0 (SD0_CLK, SD0_CMD, SD0_RST#, SD0_DATA[7:0])

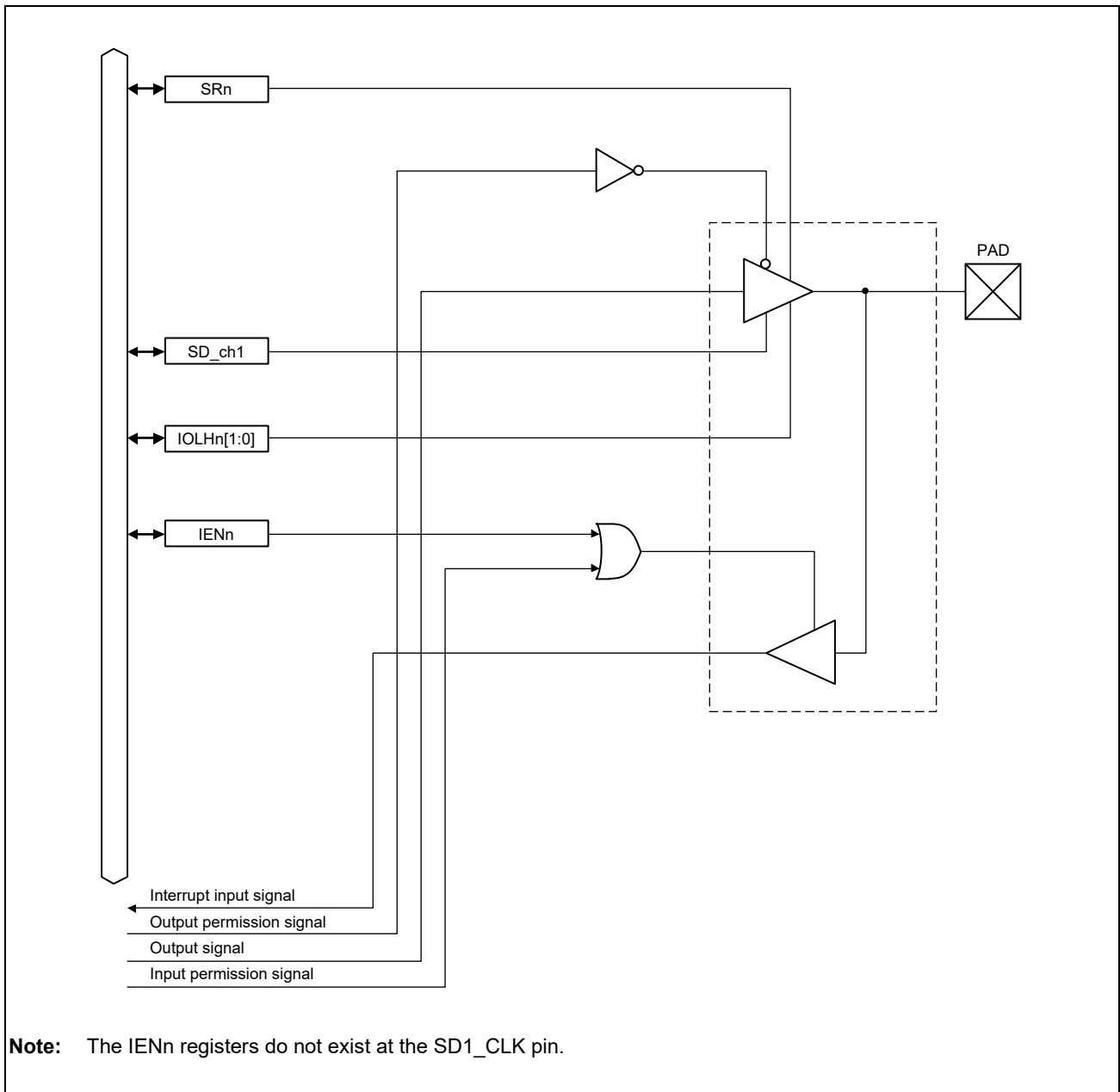

Figure 41.7 SDHI ch1 (SD1_CLK, SD1_CMD, SD1_DATA[3:0])

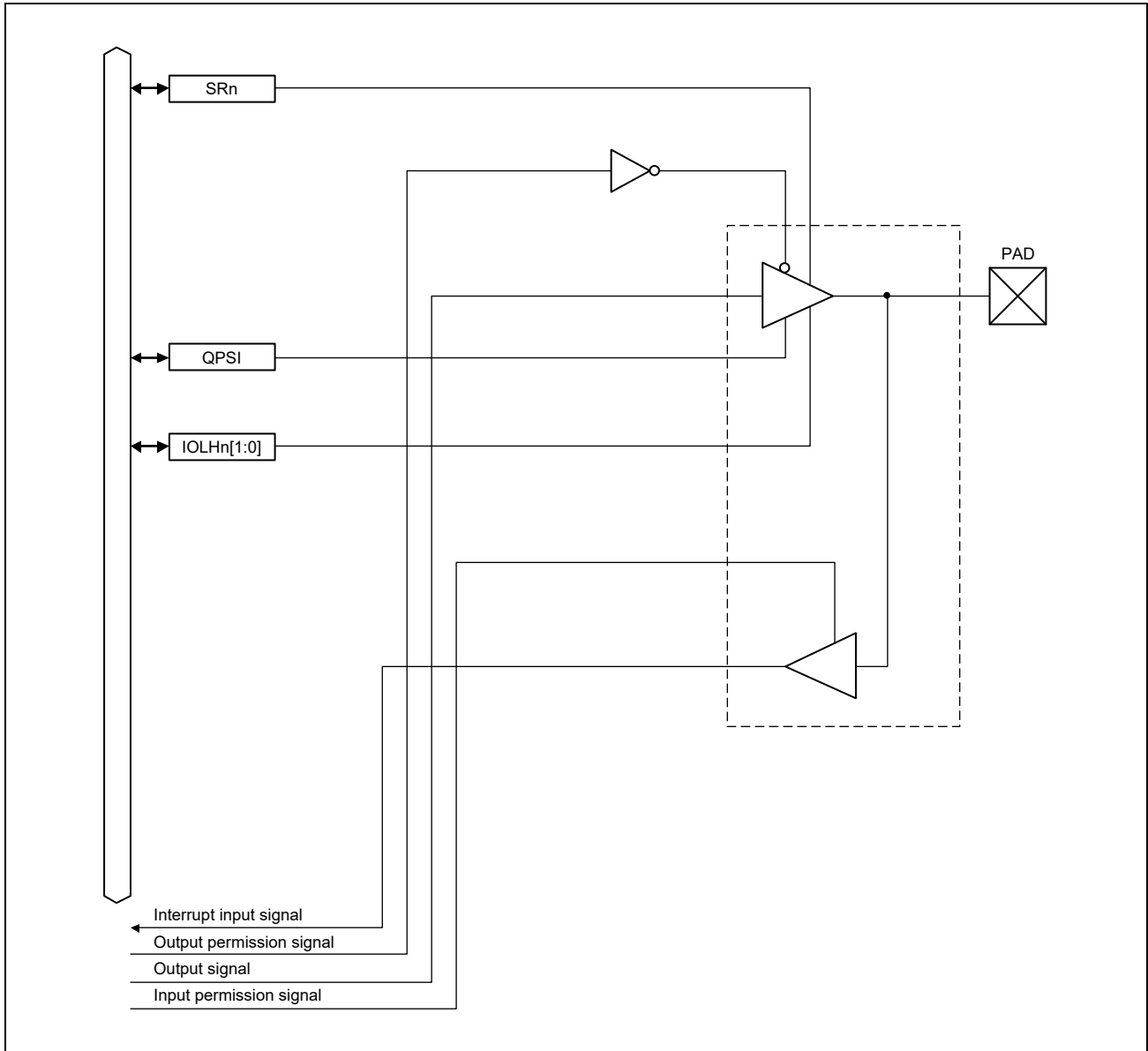

Figure 41.8 QSPI (QSPI0_SPCLK, QSPI0_IO[3:0], QSPI0_SSL, QSPI_RESET#, QSPI_WP#)

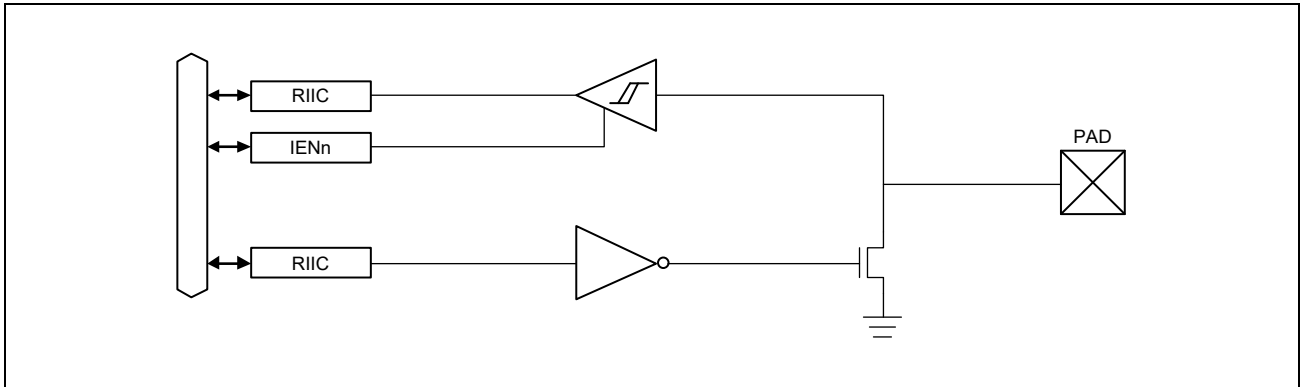

Figure 41.9 RIIC (RIIC0_SCL, RIIC0_SDA, RIIC1_SCL, RIIC1_SDA)

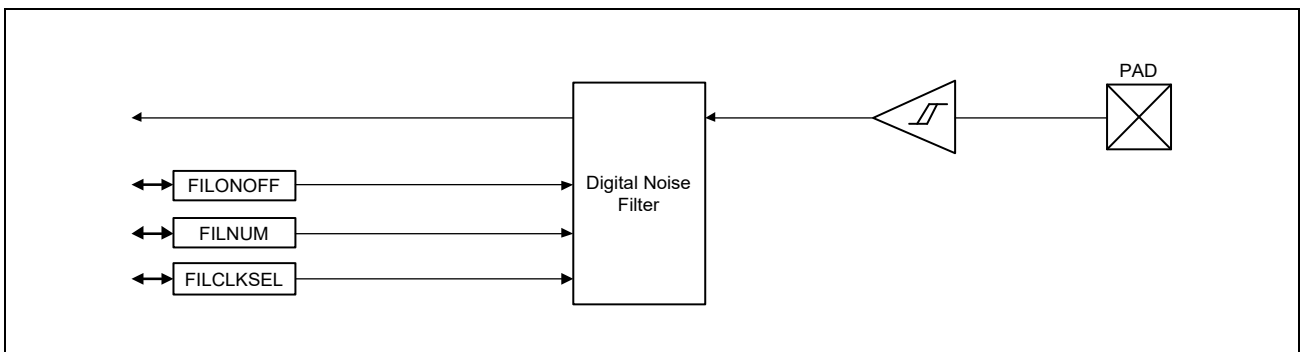

Figure 41.10 NMI

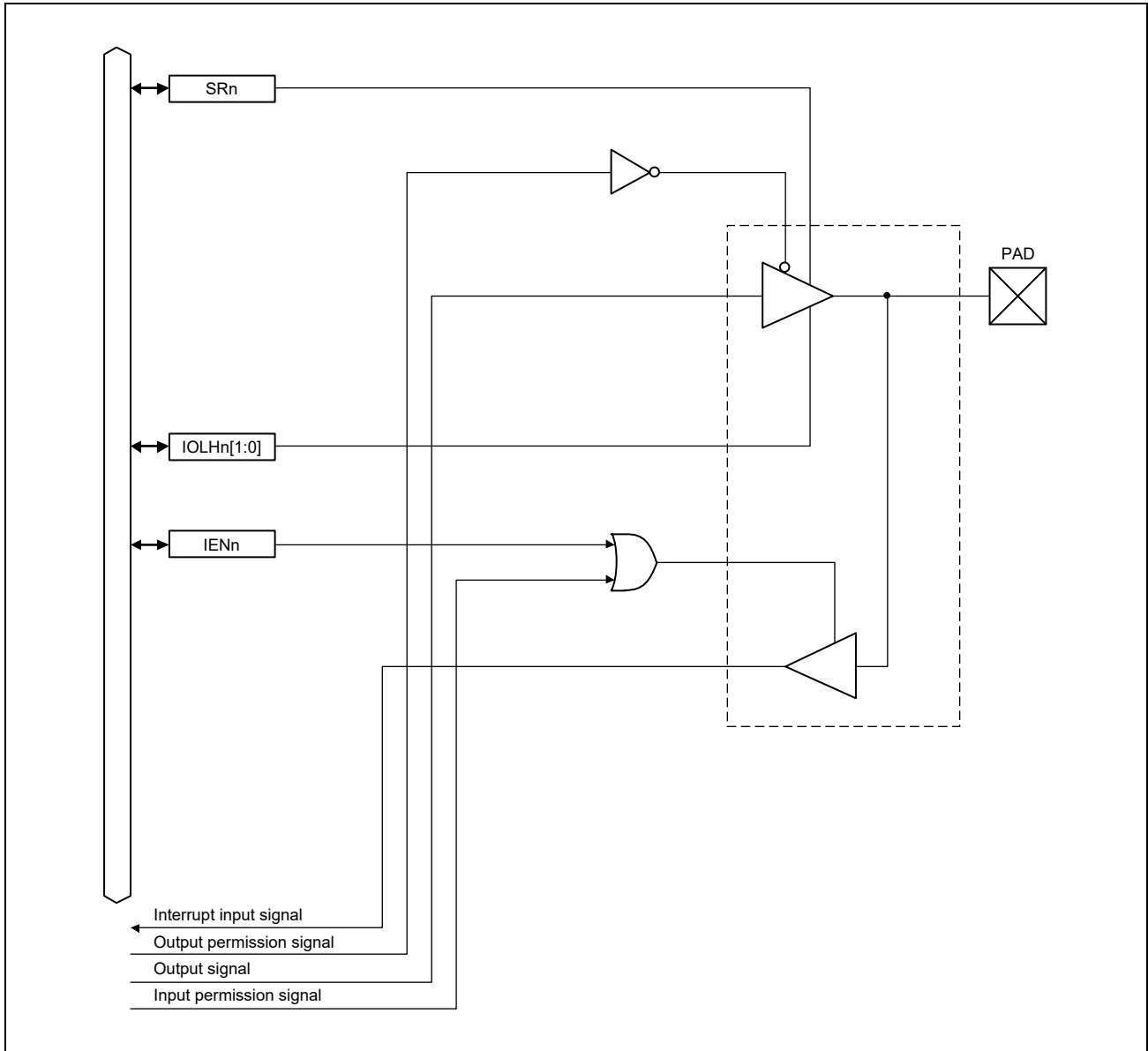

Figure 41.11 TMS/SWDIO

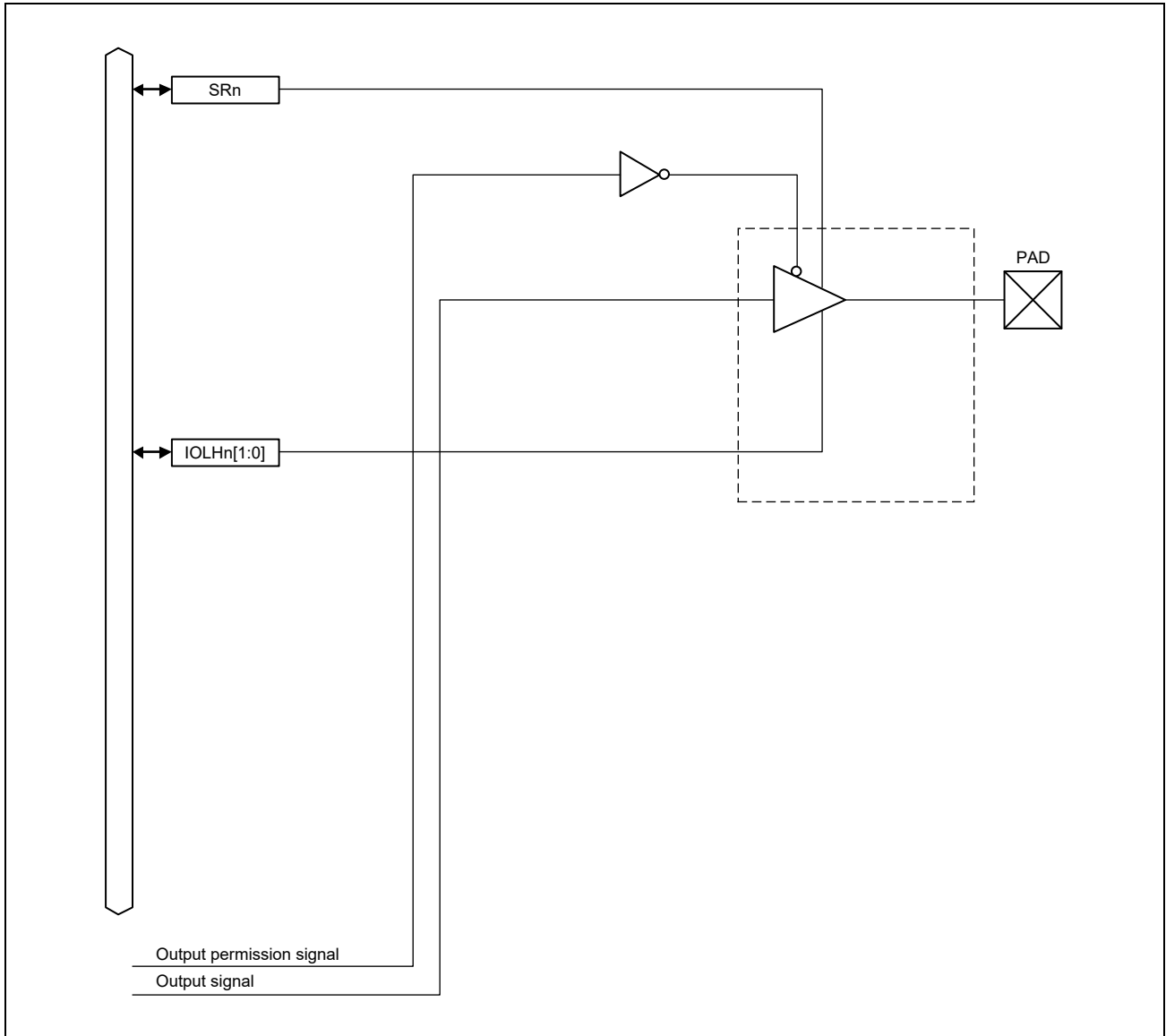

Figure 41.12 TDO

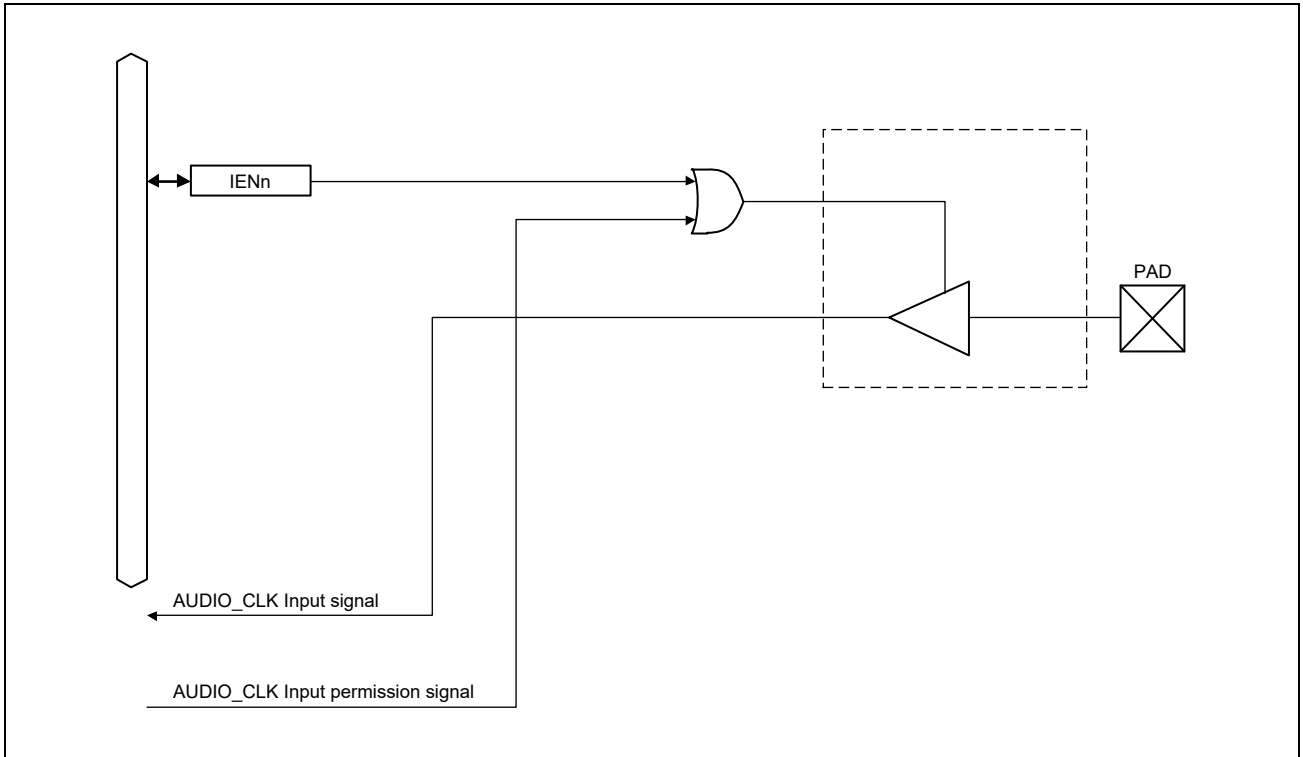

Figure 41.13 AUDIO_CLK1, AUDIO_CLK2

41.2 Register Configuration

The base address is shown below.

Base address: H'0_1103_0000 (AX45MP Address Space)

The register addresses shown in the following chapters will be offset addresses from the above base address.

NOTE

Access to areas for which Offset address is not defined in the register map is prohibited.

Please align the addresses according to the access size.

41.2.1 Port Register (Pn)

Register Name	Abbreviation	R/W	Initial Value	Address	Access Size
PORT REGISTER06	P06	R/W	H'00	H'0006	8
PORT REGISTER07	P07	R/W	H'00	H'0007	8
PORT REGISTER08	P08	R/W	H'00	H'0008	8
PORT REGISTER09	P09	R/W	H'00	H'0009	8
PORT REGISTER0A	P0A	R/W	H'00	H'000A	8
PORT REGISTER0B	P0B	R/W	H'00	H'000B	8
PORT REGISTER0C	P0C	R/W	H'00	H'000C	8
PORT REGISTER0F	P0F	R/W	H'00	H'000F	8
PORT REGISTER10	P10	R/W	H'00	H'0010	8
PORT REGISTER11	P11	R/W	H'00	H'0011	8
PORT REGISTER12	P12	R/W	H'00	H'0012	8
PORT REGISTER13	P13	R/W	H'00	H'0013	8
PORT REGISTER14	P14	R/W	H'00	H'0014	8
PORT REGISTER15	P15	R/W	H'00	H'0015	8
PORT REGISTER16	P16	R/W	H'00	H'0016	8
PORT REGISTER17	P17	R/W	H'00	H'0017	8
PORT REGISTER18	P18	R/W	H'00	H'0018	8
PORT REGISTER19	P19	R/W	H'00	H'0019	8
PORT REGISTER1A	P1A	R/W	H'00	H'001A	8
PORT REGISTER1B	P1B	R/W	H'00	H'001B	8
PORT REGISTER1C	P1C	R/W	H'00	H'001C	8
PORT REGISTER1D	P1D	R/W	H'00	H'001D	8
PORT REGISTER1E	P1E	R/W	H'00	H'001E	8
PORT REGISTER1F	P1F	R/W	H'00	H'001F	8
PORT REGISTER20	P20	R/W	H'00	H'0020	8
PORT REGISTER21	P21	R/W	H'00	H'0021	8
PORT REGISTER22	P22	R/W	H'00	H'0022	8

41.2.2 Port Mode Register (PMn)

Register Name	Abbreviation	R/W	Initial Value	Address	Access Size
PORT MODE REGISTER06	PM06	R/W	H'0000	H'010C	8/16
PORT MODE REGISTER07	PM07	R/W	H'0000	H'010E	8/16
PORT MODE REGISTER08	PM08	R/W	H'0000	H'0110	8/16
PORT MODE REGISTER09	PM09	R/W	H'0000	H'0112	8/16
PORT MODE REGISTER0A	PM0A	R/W	H'0000	H'0114	8/16
PORT MODE REGISTER0B	PM0B	R/W	H'0000	H'0116	8/16
PORT MODE REGISTER0C	PM0C	R/W	H'0000	H'0118	8/16
PORT MODE REGISTER0F	PM0F	R/W	H'0000	H'011E	8/16
PORT MODE REGISTER10	PM10	R/W	H'0000	H'0120	8/16
PORT MODE REGISTER11	PM11	R/W	H'0000	H'0122	8/16
PORT MODE REGISTER12	PM12	R/W	H'0000	H'0124	8/16
PORT MODE REGISTER13	PM13	R/W	H'0000	H'0126	8/16
PORT MODE REGISTER14	PM14	R/W	H'0000	H'0128	8/16
PORT MODE REGISTER15	PM15	R/W	H'0000	H'012A	8/16
PORT MODE REGISTER16	PM16	R/W	H'0000	H'012C	8/16
PORT MODE REGISTER17	PM17	R/W	H'0000	H'012E	8/16
PORT MODE REGISTER18	PM18	R/W	H'0000	H'0130	8/16
PORT MODE REGISTER19	PM19	R/W	H'0000	H'0132	8/16
PORT MODE REGISTER1A	PM1A	R/W	H'0000	H'0134	8/16
PORT MODE REGISTER1B	PM1B	R/W	H'0000	H'0136	8/16
PORT MODE REGISTER1C	PM1C	R/W	H'0000	H'0138	8/16
PORT MODE REGISTER1D	PM1D	R/W	H'0000	H'013A	8/16
PORT MODE REGISTER1E	PM1E	R/W	H'0000	H'013C	8/16
PORT MODE REGISTER1F	PM1F	R/W	H'0000	H'013E	8/16
PORT MODE REGISTER20	PM20	R/W	H'0000	H'0140	8/16
PORT MODE REGISTER21	PM21	R/W	H'0000	H'0142	8/16
PORT MODE REGISTER22	PM22	R/W	H'0000	H'0144	8/16

41.2.3 Port Mode Control Register (PMCn)

Register Name	Abbreviation	R/W	Initial Value	Address	Access Size
PORT MODE CONTROL REGISTER06	PMC06	R/W	H'00	H'0206	8
PORT MODE CONTROL REGISTER07	PMC07	R/W	H'00	H'0207	8
PORT MODE CONTROL REGISTER08	PMC08	R/W	H'00	H'0208	8
PORT MODE CONTROL REGISTER09	PMC09	R/W	H'00	H'0209	8
PORT MODE CONTROL REGISTER0A	PMC0A	R/W	H'00	H'020A	8
PORT MODE CONTROL REGISTER0B	PMC0B	R/W	H'00	H'020B	8
PORT MODE CONTROL REGISTER0C	PMC0C	R/W	H'00	H'020C	8
PORT MODE CONTROL REGISTER0F	PMC0F	R/W	H'00	H'020F	8
PORT MODE CONTROL REGISTER10	PMC10	R/W	H'00	H'0210	8
PORT MODE CONTROL REGISTER11	PMC11	R/W	H'00	H'0211	8
PORT MODE CONTROL REGISTER12	PMC12	R/W	H'00	H'0212	8
PORT MODE CONTROL REGISTER13	PMC13	R/W	H'00	H'0213	8

Register Name	Abbreviation	R/W	Initial Value	Address	Access Size
PORT MODE CONTROL REGISTER14	PMC14	R/W	H'00	H'0214	8
PORT MODE CONTROL REGISTER15	PMC15	R/W	H'00	H'0215	8
PORT MODE CONTROL REGISTER16	PMC16	R/W	H'00	H'0216	8
PORT MODE CONTROL REGISTER17	PMC17	R/W	H'00	H'0217	8
PORT MODE CONTROL REGISTER18	PMC18	R/W	H'00	H'0218	8
PORT MODE CONTROL REGISTER19	PMC19	R/W	H'00	H'0219	8
PORT MODE CONTROL REGISTER1A	PMC1A	R/W	H'00	H'021A	8
PORT MODE CONTROL REGISTER1B	PMC1B	R/W	H'00	H'021B	8
PORT MODE CONTROL REGISTER1C	PMC1C	R/W	H'00	H'021C	8
PORT MODE CONTROL REGISTER1D	PMC1D	R/W	H'00	H'021D	8
PORT MODE CONTROL REGISTER1E	PMC1E	R/W	H'00	H'021E	8
PORT MODE CONTROL REGISTER1F	PMC1F	R/W	H'00	H'021F	8
PORT MODE CONTROL REGISTER20	PMC20	R/W	H'00	H'0220	8
PORT MODE CONTROL REGISTER21	PMC21	R/W	H'00	H'0221	8
PORT MODE CONTROL REGISTER22	PMC22	R/W	H'00	H'0222	8

41.2.4 Port Function Control Register (PFCm)

Register Name	Abbreviation	R/W	Initial Value	Address	Access Size
PORT FUNCTION CONTROL REGISTER06	PFC06	R/W	H'0000 0000	H'0418	8/16/32
PORT FUNCTION CONTROL REGISTER07	PFC07	R/W	H'0000 0000	H'041C	8/16/32
PORT FUNCTION CONTROL REGISTER08	PFC08	R/W	H'0000 0000	H'0420	8/16/32
PORT FUNCTION CONTROL REGISTER09	PFC09	R/W	H'0000 0000	H'0424	8/16/32
PORT FUNCTION CONTROL REGISTER0A	PFC0A	R/W	H'0000 0000	H'0428	8/16/32
PORT FUNCTION CONTROL REGISTER0B	PFC0B	R/W	H'0000 0000	H'042C	8/16/32
PORT FUNCTION CONTROL REGISTER0C	PFC0C	R/W	H'0000 0000	H'0430	8/16/32
PORT FUNCTION CONTROL REGISTER0F	PFC0F	R/W	H'0000 0000	H'043C	8/16/32
PORT FUNCTION CONTROL REGISTER10	PFC10	R/W	H'0000 0000	H'0440	8/16/32
PORT FUNCTION CONTROL REGISTER11	PFC11	R/W	H'0000 0000	H'0444	8/16/32
PORT FUNCTION CONTROL REGISTER12	PFC12	R/W	H'0000 0000	H'0448	8/16/32
PORT FUNCTION CONTROL REGISTER13	PFC13	R/W	H'0000 0000	H'044C	8/16/32
PORT FUNCTION CONTROL REGISTER14	PFC14	R/W	H'0000 0000	H'0450	8/16/32
PORT FUNCTION CONTROL REGISTER15	PFC15	R/W	H'0000 0000	H'0454	8/16/32
PORT FUNCTION CONTROL REGISTER16	PFC16	R/W	H'0000 0000	H'0458	8/16/32
PORT FUNCTION CONTROL REGISTER17	PFC17	R/W	H'0000 0000	H'045C	8/16/32
PORT FUNCTION CONTROL REGISTER18	PFC18	R/W	H'0000 0000	H'0460	8/16/32
PORT FUNCTION CONTROL REGISTER19	PFC19	R/W	H'0000 0000	H'0464	8/16/32
PORT FUNCTION CONTROL REGISTER1A	PFC1A	R/W	H'0000 0000	H'0468	8/16/32
PORT FUNCTION CONTROL REGISTER1B	PFC1B	R/W	H'0000 0000	H'046C	8/16/32
PORT FUNCTION CONTROL REGISTER1C	PFC1C	R/W	H'0000 0000	H'0470	8/16/32
PORT FUNCTION CONTROL REGISTER1D	PFC1D	R/W	H'0000 0000	H'0474	8/16/32
PORT FUNCTION CONTROL REGISTER1E	PFC1E	R/W	H'0000 0000	H'0478	8/16/32
PORT FUNCTION CONTROL REGISTER1F	PFC1F	R/W	H'0000 0000	H'047C	8/16/32
PORT FUNCTION CONTROL REGISTER20	PFC20	R/W	H'0000 0000	H'0480	8/16/32
PORT FUNCTION CONTROL REGISTER21	PFC21	R/W	H'0000 0000	H'0484	8/16/32
PORT FUNCTION CONTROL REGISTER22	PFC22	R/W	H'0000 0000	H'0488	8/16/32

41.2.5 Port Input Register (PINn)

Register Name	Abbreviation	R/W	Initial Value	Address	Access Size
PORT INPUT REGISTER06	PIN06	R	H'00	H'0806	8
PORT INPUT REGISTER07	PIN07	R	H'00	H'0807	8
PORT INPUT REGISTER08	PIN08	R	H'00	H'0808	8
PORT INPUT REGISTER09	PIN09	R	H'00	H'0809	8
PORT INPUT REGISTER0A	PIN0A	R	H'00	H'080A	8
PORT INPUT REGISTER0B	PIN0B	R	H'00	H'080B	8
PORT INPUT REGISTER0C	PIN0C	R	H'00	H'080C	8
PORT INPUT REGISTER0F	PIN0F	R	H'00	H'080F	8
PORT INPUT REGISTER10	PIN10	R	H'00	H'0810	8
PORT INPUT REGISTER11	PIN11	R	H'00	H'0811	8
PORT INPUT REGISTER12	PIN12	R	H'00	H'0812	8
PORT INPUT REGISTER13	PIN13	R	H'00	H'0813	8
PORT INPUT REGISTER14	PIN14	R	H'00	H'0814	8
PORT INPUT REGISTER15	PIN15	R	H'00	H'0815	8
PORT INPUT REGISTER16	PIN16	R	H'00	H'0816	8
PORT INPUT REGISTER17	PIN17	R	H'00	H'0817	8
PORT INPUT REGISTER18	PIN18	R	H'00	H'0818	8
PORT INPUT REGISTER19	PIN19	R	H'00	H'0819	8
PORT INPUT REGISTER1A	PIN1A	R	H'00	H'081A	8
PORT INPUT REGISTER1B	PIN1B	R	H'00	H'081B	8
PORT INPUT REGISTER1C	PIN1C	R	H'00	H'081C	8
PORT INPUT REGISTER1D	PIN1D	R	H'00	H'081D	8
PORT INPUT REGISTER1E	PIN1E	R	H'00	H'081E	8
PORT INPUT REGISTER1F	PIN1F	R	H'00	H'081F	8
PORT INPUT REGISTER20	PIN20	R	H'00	H'0820	8
PORT INPUT REGISTER21	PIN21	R	H'00	H'0821	8
PORT INPUT REGISTER22	PIN22	R	H'00	H'0822	8

41.2.6 Interrupt Enable Control Register (ISEL)

Register Name	Abbreviation	R/W	Initial Value	Address	Access Size
INTERRUPT ENABLE CONTROL REGISTER10	ISEL10	R/W	H'0000 0000	H'2C80	8/16/32
INTERRUPT ENABLE CONTROL REGISTER11_L	ISEL11_L	R/W	H'0000 0000	H'2C88	8/16/32
INTERRUPT ENABLE CONTROL REGISTER11_H	ISEL11_H	R/W	H'0000 0000	H'2C8C	8/16/32
INTERRUPT ENABLE CONTROL REGISTER12	ISEL12	R/W	H'0000 0000	H'2C90	8/16/32
INTERRUPT ENABLE CONTROL REGISTER13	ISEL13	R/W	H'0000 0000	H'2C98	8/16/32
INTERRUPT ENABLE CONTROL REGISTER14_L	ISEL14_L	R/W	H'0000 0000	H'2CA0	8/16/32
INTERRUPT ENABLE CONTROL REGISTER14_H	ISEL14_H	R/W	H'0000 0000	H'2CA4	8/16/32
INTERRUPT ENABLE CONTROL REGISTER15_L	ISEL15_L	R/W	H'0000 0000	H'2CA8	8/16/32
INTERRUPT ENABLE CONTROL REGISTER15_H	ISEL15_H	R/W	H'0000 0000	H'2CAC	8/16/32
INTERRUPT ENABLE CONTROL REGISTER16_L	ISEL16_L	R/W	H'0000 0000	H'2CB0	8/16/32
INTERRUPT ENABLE CONTROL REGISTER16_H	ISEL16_H	R/W	H'0000 0000	H'2CB4	8/16/32
INTERRUPT ENABLE CONTROL REGISTER17_L	ISEL17_L	R/W	H'0000 0000	H'2CB8	8/16/32

Register Name	Abbreviation	R/W	Initial Value	Address	Access Size
INTERRUPT ENABLE CONTROL REGISTER17_H	ISEL17_H	R/W	H'0000 0000	H'2CBC	8/16/32
INTERRUPT ENABLE CONTROL REGISTER18_L	ISEL18_L	R/W	H'0000 0000	H'2CC0	8/16/32
INTERRUPT ENABLE CONTROL REGISTER18_H	ISEL18_H	R/W	H'0000 0000	H'2CC4	8/16/32
INTERRUPT ENABLE CONTROL REGISTER19	ISEL19	R/W	H'0000 0000	H'2CC8	8/16/32
INTERRUPT ENABLE CONTROL REGISTER1A_L	ISEL1A_L	R/W	H'0000 0000	H'2CD0	8/16/32
INTERRUPT ENABLE CONTROL REGISTER1A_H	ISEL1A_H	R/W	H'0000 0000	H'2CD4	8/16/32
INTERRUPT ENABLE CONTROL REGISTER1B	ISEL1B	R/W	H'0000 0000	H'2CD8	8/16/32
INTERRUPT ENABLE CONTROL REGISTER1C	ISEL1C	R/W	H'0000 0000	H'2CE0	8/16/32
INTERRUPT ENABLE CONTROL REGISTER1D_L	ISEL1D_L	R/W	H'0000 0000	H'2CE8	8/16/32
INTERRUPT ENABLE CONTROL REGISTER1D_H	ISEL1D_H	R/W	H'0000 0000	H'2CEC	8/16/32
INTERRUPT ENABLE CONTROL REGISTER1E	ISEL1E	R/W	H'0000 0000	H'2CF0	8/16/32
INTERRUPT ENABLE CONTROL REGISTER1F	ISEL1F	R/W	H'0000 0000	H'2CF8	8/16/32
INTERRUPT ENABLE CONTROL REGISTER20	ISEL20	R/W	H'0000 0000	H'2D00	8/16/32
INTERRUPT ENABLE CONTROL REGISTER21	ISEL21	R/W	H'0000 0000	H'2D08	8/16/32
INTERRUPT ENABLE CONTROL REGISTER22_L	ISEL22_L	R/W	H'0000 0000	H'2D10	8/16/32
INTERRUPT ENABLE CONTROL REGISTER22_H	ISEL22_H	R/W	H'0000 0000	H'2D14	8/16/32

41.2.7 Driving Ability Control Register (IOLH)

Register Name	Abbreviation	R/W	Initial Value	Address	Access Size
DRIVING ABILITY CONTROL REGISTER02	IOLH02	R/W	*1	H'1010	8/16/32
DRIVING ABILITY CONTROL REGISTER03	IOLH03	R/W	*1	H'1018	8/16/32
DRIVING ABILITY CONTROL REGISTER06	IOLH06	R/W	*1	H'1030	8/16/32
DRIVING ABILITY CONTROL REGISTER07_L	IOLH07_L	R/W	*1	H'1038	8/16/32
DRIVING ABILITY CONTROL REGISTER07_H	IOLH07_H	R/W	*1	H'103C	8/16/32
DRIVING ABILITY CONTROL REGISTER08	IOLH08	R/W	*1	H'1040	8/16/32
DRIVING ABILITY CONTROL REGISTER09	IOLH09	R/W	*1	H'1048	8/16/32
DRIVING ABILITY CONTROL REGISTER0A_L	IOLH0A_L	R/W	*1	H'1050	8/16/32
DRIVING ABILITY CONTROL REGISTER0A_H	IOLH0A_H	R/W	*1	H'1054	8/16/32
DRIVING ABILITY CONTROL REGISTER0B_L	IOLH0B_L	R/W	*1	H'1058	8/16/32
DRIVING ABILITY CONTROL REGISTER0B_H	IOLH0B_H	R/W	*1	H'105C	8/16/32
DRIVING ABILITY CONTROL REGISTER0C	IOLH0C	R/W	*1	H'1060	8/16/32
DRIVING ABILITY CONTROL REGISTER0F_L	IOLH0F_L	R/W	*1	H'1078	8/16/32
DRIVING ABILITY CONTROL REGISTER0F_H	IOLH0F_H	R/W	*1	H'107C	8/16/32
DRIVING ABILITY CONTROL REGISTER10	IOLH10	R/W	*1	H'1080	8/16/32
DRIVING ABILITY CONTROL REGISTER15_L	IOLH15_L	R/W	*1	H'10A8	8/16/32
DRIVING ABILITY CONTROL REGISTER15_H	IOLH15_H	R/W	*1	H'10AC	8/16/32
DRIVING ABILITY CONTROL REGISTER16_L	IOLH16_L	R/W	*1	H'10B0	8/16/32
DRIVING ABILITY CONTROL REGISTER16_H	IOLH16_H	R/W	*1	H'10B4	8/16/32
DRIVING ABILITY CONTROL REGISTER1B	IOLH1B	R/W	*1	H'10D8	8/16/32
DRIVING ABILITY CONTROL REGISTER1C	IOLH1C	R/W	*1	H'10E0	8/16/32
DRIVING ABILITY CONTROL REGISTER1D_L	IOLH1D_L	R/W	*1	H'10E8	8/16/32
DRIVING ABILITY CONTROL REGISTER1D_H	IOLH1D_H	R/W	*1	H'10EC	8/16/32
DRIVING ABILITY CONTROL REGISTER1E	IOLH1E	R/W	*1	H'10F0	8/16/32
DRIVING ABILITY CONTROL REGISTER1F	IOLH1F	R/W	*1	H'10F8	8/16/32
DRIVING ABILITY CONTROL REGISTER20	IOLH20	R/W	*1	H'1100	8/16/32

Register Name	Abbreviation	R/W	Initial Value	Address	Access Size
DRIVING ABILITY CONTROL REGISTER21	IOLH21	R/W	*1	H'1108	8/16/32
DRIVING ABILITY CONTROL REGISTER22_L	IOLH22_L	R/W	*1	H'1110	8/16/32
DRIVING ABILITY CONTROL REGISTER22_H	IOLH22_H	R/W	*1	H'1114	8/16/32

Note 1. For the initial value, refer to **Section 41.3.7, Driving Ability Control Register (IOLH)**.

41.2.8 Slew Rate Switching Register (SR)

Register Name	Abbreviation	R/W	Initial Value	Address	Access Size
SLEW RATE SWITCHING REGISTER02	SR02	R/W	*1	H'1410	8/16/32
SLEW RATE SWITCHING REGISTER03	SR03	R/W	*1	H'1418	8/16/32
SLEW RATE SWITCHING REGISTER06	SR06	R/W	*1	H'1430	8/16/32
SLEW RATE SWITCHING REGISTER07_L	SR07_L	R/W	*1	H'1438	8/16/32
SLEW RATE SWITCHING REGISTER07_H	SR07_H	R/W	*1	H'143C	8/16/32
SLEW RATE SWITCHING REGISTER08	SR08	R/W	*1	H'1440	8/16/32
SLEW RATE SWITCHING REGISTER09	SR09	R/W	*1	H'1448	8/16/32
SLEW RATE SWITCHING REGISTER0A_L	SR0A_L	R/W	*1	H'1450	8/16/32
SLEW RATE SWITCHING REGISTER0A_H	SR0A_H	R/W	*1	H'1454	8/16/32
SLEW RATE SWITCHING REGISTER0B_L	SR0B_L	R/W	*1	H'1458	8/16/32
SLEW RATE SWITCHING REGISTER0B_H	SR0B_H	R/W	*1	H'145C	8/16/32
SLEW RATE SWITCHING REGISTER0C	SR0C	R/W	*1	H'1460	8/16/32
SLEW RATE SWITCHING REGISTER0F_L	SR0F_L	R/W	*1	H'1478	8/16/32
SLEW RATE SWITCHING REGISTER0F_H	SR0F_H	R/W	*1	H'147C	8/16/32
SLEW RATE SWITCHING REGISTER10	SR10	R/W	*1	H'1480	8/16/32
SLEW RATE SWITCHING REGISTER15_L	SR15_L	R/W	*1	H'14A8	8/16/32
SLEW RATE SWITCHING REGISTER15_H	SR15_H	R/W	*1	H'14AC	8/16/32
SLEW RATE SWITCHING REGISTER16_L	SR16_L	R/W	*1	H'14B0	8/16/32
SLEW RATE SWITCHING REGISTER16_H	SR16_H	R/W	*1	H'14B4	8/16/32
SLEW RATE SWITCHING REGISTER1B	SR1B	R/W	*1	H'14D8	8/16/32
SLEW RATE SWITCHING REGISTER1C	SR1C	R/W	*1	H'14E0	8/16/32
SLEW RATE SWITCHING REGISTER1D_L	SR1D_L	R/W	*1	H'14E8	8/16/32
SLEW RATE SWITCHING REGISTER1D_H	SR1D_H	R/W	*1	H'14EC	8/16/32
SLEW RATE SWITCHING REGISTER1E	SR1E	R/W	*1	H'14F0	8/16/32
SLEW RATE SWITCHING REGISTER1F	SR1F	R/W	*1	H'14F8	8/16/32
SLEW RATE SWITCHING REGISTER20	SR20	R/W	*1	H'1500	8/16/32
SLEW RATE SWITCHING REGISTER21	SR21	R/W	*1	H'1508	8/16/32
SLEW RATE SWITCHING REGISTER22_L	SR22_L	R/W	*1	H'1510	8/16/32
SLEW RATE SWITCHING REGISTER22_H	SR22_H	R/W	*1	H'1514	8/16/32

Note 1. For the initial value, refer to **Section 41.3.8, Slew Rate Switching Register (SR)**.

41.2.9 Pull Up/Pull down Switching Register (PUPD)

Register Name	Abbreviation	R/W	Initial Value	Address	Access Size
PULL UP/PULL DOWN SWITCHING REGISTER06	PUPD06	R/W	H'0000 0000	H'1C30	8/16/32
PULL UP/PULL DOWN SWITCHING REGISTER07_L	PUPD07_L	R/W	H'0000 0000	H'1C38	8/16/32
PULL UP/PULL DOWN SWITCHING REGISTER07_H	PUPD07_H	R/W	H'0000 0000	H'1C3C	8/16/32

Register Name	Abbreviation	R/W	Initial Value	Address	Access Size
PULL UP/PULL DOWN SWITCHING REGISTER08	PUPD08	R/W	H'0000 0000	H'1C40	8/16/32
PULL UP/PULL DOWN SWITCHING REGISTER09	PUPD09	R/W	H'0000 0000	H'1C48	8/16/32
PULL UP/PULL DOWN SWITCHING REGISTER0A_L	PUPD0A_L	R/W	H'0000 0000	H'1C50	8/16/32
PULL UP/PULL DOWN SWITCHING REGISTER0A_H	PUPD0A_H	R/W	H'0000 0000	H'1C54	8/16/32
PULL UP/PULL DOWN SWITCHING REGISTER0B_L	PUPD0B_L	R/W	H'0000 0000	H'1C58	8/16/32
PULL UP/PULL DOWN SWITCHING REGISTER0B_H	PUPD0B_H	R/W	H'0000 0000	H'1C5C	8/16/32
PULL UP/PULL DOWN SWITCHING REGISTER0F_L	PUPD0F_L	R/W	H'0000 0000	H'1C78	8/16/32
PULL UP/PULL DOWN SWITCHING REGISTER0F_H	PUPD0F_H	R/W	H'0000 0000	H'1C7C	8/16/32
PULL UP/PULL DOWN SWITCHING REGISTER10	PUPD10	R/W	H'0000 0000	H'1C80	8/16/32
PULL UP/PULL DOWN SWITCHING REGISTER15_L	PUPD15_L	R/W	H'0000 0000	H'1CA8	8/16/32
PULL UP/PULL DOWN SWITCHING REGISTER15_H	PUPD15_H	R/W	H'0000 0000	H'1CAC	8/16/32
PULL UP/PULL DOWN SWITCHING REGISTER16_L	PUPD16_L	R/W	H'0000 0000	H'1CB0	8/16/32
PULL UP/PULL DOWN SWITCHING REGISTER16_H	PUPD16_H	R/W	H'0000 0000	H'1CB4	8/16/32
PULL UP/PULL DOWN SWITCHING REGISTER1B	PUPD1B	R/W	H'0000 0000	H'1CD8	8/16/32
PULL UP/PULL DOWN SWITCHING REGISTER1C	PUPD1C	R/W	H'0000 0000	H'1CE0	8/16/32
PULL UP/PULL DOWN SWITCHING REGISTER1D_L	PUPD1D_L	R/W	H'0000 0000	H'1CE8	8/16/32
PULL UP/PULL DOWN SWITCHING REGISTER1D_H	PUPD1D_H	R/W	H'0000 0000	H'1CEC	8/16/32
PULL UP/PULL DOWN SWITCHING REGISTER1E	PUPD1E	R/W	H'0000 0000	H'1CF0	8/16/32
PULL UP/PULL DOWN SWITCHING REGISTER1F	PUPD1F	R/W	H'0000 0000	H'1CF8	8/16/32
PULL UP/PULL DOWN SWITCHING REGISTER20	PUPD20	R/W	H'0000 0000	H'1D00	8/16/32
PULL UP/PULL DOWN SWITCHING REGISTER21	PUPD21	R/W	H'0000 0000	H'1D08	8/16/32
PULL UP/PULL DOWN SWITCHING REGISTER22_L	PUPD22_L	R/W	H'0000 0000	H'1D10	8/16/32
PULL UP/PULL DOWN SWITCHING REGISTER22_H	PUPD22_H	R/W	H'0000 0000	H'1D14	8/16/32

41.2.10 Write protected register (PWPR)

Register Name	Abbreviation	R/W	Initial Value	Address	Access Size
WRITE PROTECTED REGISTER	PWPR	R/W	H'80	H'3014	8

41.2.11 Digital Noise Filter Switching Register (FILONOFF)

Register Name	Abbreviation	R/W	Initial Value	Address	Access Size
DIGITAL NOISE FILTER SWITCHING REGISTER01	FILONOFF01	R/W	H'0000 0000	H'2008	8/16/32
DIGITAL NOISE FILTER SWITCHING REGISTER06	FILONOFF06	R/W	H'0000 0000	H'2030	8/16/32
DIGITAL NOISE FILTER SWITCHING REGISTER07	FILONOFF07	R/W	H'0000 0000	H'2038	8/16/32
DIGITAL NOISE FILTER SWITCHING REGISTER0B_L	FILONOFF0B_L	R/W	H'0000 0000	H'2058	8/16/32
DIGITAL NOISE FILTER SWITCHING REGISTER0B_H	FILONOFF0B_H	R/W	H'0000 0000	H'205C	8/16/32
DIGITAL NOISE FILTER SWITCHING REGISTER0C	FILONOFF0C	R/W	H'0000 0000	H'2060	8/16/32
DIGITAL NOISE FILTER SWITCHING REGISTER0F_L	FILONOFF0F_L	R/W	H'0000 0000	H'2078	8/16/32

Register Name	Abbreviation	R/W	Initial Value	Address	Access Size
DIGITAL NOISE FILTER SWITCHING REGISTER0F_H	FILONOFF0F_H	R/W	H'0000 0000	H'207C	8/16/32
DIGITAL NOISE FILTER SWITCHING REGISTER 10	FILONOFF10	R/W	H'0000 0000	H'2080	8/16/32
DIGITAL NOISE FILTER SWITCHING REGISTER11_L	FILONOFF11_L	R/W	H'0000 0000	H'2088	8/16/32
DIGITAL NOISE FILTER SWITCHING REGISTER11_H	FILONOFF11_H	R/W	H'0000 0000	H'208C	8/16/32
DIGITAL NOISE FILTER SWITCHING REGISTER12	FILONOFF12	R/W	H'0000 0000	H'2090	8/16/32
DIGITAL NOISE FILTER SWITCHING REGISTER13	FILONOFF13	R/W	H'0000 0000	H'2098	8/16/32
DIGITAL NOISE FILTER SWITCHING REGISTER14_L	FILONOFF14_L	R/W	H'0000 0000	H'20A0	8/16/32
DIGITAL NOISE FILTER SWITCHING REGISTER14_H	FILONOFF14_H	R/W	H'0000 0000	H'20A4	8/16/32
DIGITAL NOISE FILTER SWITCHING REGISTER15_L	FILONOFF15_L	R/W	H'0000 0000	H'20A8	8/16/32
DIGITAL NOISE FILTER SWITCHING REGISTER15_H	FILONOFF15_H	R/W	H'0000 0000	H'20AC	8/16/32
DIGITAL NOISE FILTER SWITCHING REGISTER16_L	FILONOFF16_L	R/W	H'0000 0000	H'20B0	8/16/32
DIGITAL NOISE FILTER SWITCHING REGISTER16_H	FILONOFF16_H	R/W	H'0000 0000	H'20B4	8/16/32
DIGITAL NOISE FILTER SWITCHING REGISTER17_L	FILONOFF17_L	R/W	H'0000 0000	H'20B8	8/16/32
DIGITAL NOISE FILTER SWITCHING REGISTER17_H	FILONOFF17_H	R/W	H'0000 0000	H'20BC	8/16/32
DIGITAL NOISE FILTER SWITCHING REGISTER18_L	FILONOFF18_L	R/W	H'0000 0000	H'20C0	8/16/32
DIGITAL NOISE FILTER SWITCHING REGISTER18_H	FILONOFF18_H	R/W	H'0000 0000	H'20C4	8/16/32
DIGITAL NOISE FILTER SWITCHING REGISTER19	FILONOFF19	R/W	H'0000 0000	H'20C8	8/16/32
DIGITAL NOISE FILTER SWITCHING REGISTER1A_L	FILONOFF1A_L	R/W	H'0000 0000	H'20D0	8/16/32
DIGITAL NOISE FILTER SWITCHING REGISTER1A_H	FILONOFF1A_H	R/W	H'0000 0000	H'20D4	8/16/32
DIGITAL NOISE FILTER SWITCHING REGISTER1B	FILONOFF1B	R/W	H'0000 0000	H'20D8	8/16/32
DIGITAL NOISE FILTER SWITCHING REGISTER1C	FILONOFF1C	R/W	H'0000 0000	H'20E0	8/16/32
DIGITAL NOISE FILTER SWITCHING REGISTER1D_L	FILONOFF1D_L	R/W	H'0000 0000	H'20E8	8/16/32
DIGITAL NOISE FILTER SWITCHING REGISTER1D_H	FILONOFF1D_H	R/W	H'0000 0000	H'20EC	8/16/32
DIGITAL NOISE FILTER SWITCHING REGISTER1E	FILONOFF1E	R/W	H'0000 0000	H'20F0	8/16/32
DIGITAL NOISE FILTER SWITCHING REGISTER1F	FILONOFF1F	R/W	H'0000 0000	H'20F8	8/16/32
DIGITAL NOISE FILTER SWITCHING REGISTER20	FILONOFF20	R/W	H'0000 0000	H'2100	8/16/32
DIGITAL NOISE FILTER SWITCHING REGISTER21	FILONOFF21	R/W	H'0000 0000	H'2108	8/16/32

Register Name	Abbreviation	R/W	Initial Value	Address	Access Size
DIGITAL NOISE FILTER SWITCHING REGISTER22_L	FILONOFF22_L	R/W	H'0000 0000	H'2110	8/16/32
DIGITAL NOISE FILTER SWITCHING REGISTER22_H	FILONOFF22_H	R/W	H'0000 0000	H'2114	8/16/32

41.2.12 Digital Noise Filter Number Register (FILNUM)

Register Name	Abbreviation	R/W	Initial Value	Address	Access Size
DIGITAL NOISE FILTER NUMBER REGISTER 01	FILNUM01	R/W	H'0000 0000	H'2408	8/16/32
DIGITAL NOISE FILTER NUMBER REGISTER06	FILNUM06	R/W	H'0000 0000	H'2430	8/16/32
DIGITAL NOISE FILTER NUMBER REGISTER07	FILNUM07	R/W	H'0000 0000	H'2438	8/16/32
DIGITAL NOISE FILTER NUMBER REGISTER0B_L	FILNUM0B_L	R/W	H'0000 0000	H'2458	8/16/32
DIGITAL NOISE FILTER NUMBER REGISTER0B_H	FILNUM0B_H	R/W	H'0000 0000	H'245C	8/16/32
DIGITAL NOISE FILTER NUMBER REGISTER0C	FILNUM0C	R/W	H'0000 0000	H'2460	8/16/32
DIGITAL NOISE FILTER NUMBER REGISTER0F_L	FILNUM0F_L	R/W	H'0000 0000	H'2478	8/16/32
DIGITAL NOISE FILTER NUMBER REGISTER0F_H	FILNUM0F_H	R/W	H'0000 0000	H'247C	8/16/32
DIGITAL NOISE FILTER NUMBER REGISTER 10	FILNUM10	R/W	H'0000 0000	H'2480	8/16/32
DIGITAL NOISE FILTER NUMBER REGISTER11_L	FILNUM11_L	R/W	H'0000 0000	H'2488	8/16/32
DIGITAL NOISE FILTER NUMBER REGISTER11_H	FILNUM11_H	R/W	H'0000 0000	H'248C	8/16/32
DIGITAL NOISE FILTER NUMBER REGISTER12	FILNUM12	R/W	H'0000 0000	H'2490	8/16/32
DIGITAL NOISE FILTER NUMBER REGISTER13	FILNUM13	R/W	H'0000 0000	H'2498	8/16/32
DIGITAL NOISE FILTER NUMBER REGISTER14_L	FILNUM14_L	R/W	H'0000 0000	H'24A0	8/16/32
DIGITAL NOISE FILTER NUMBER REGISTER14_H	FILNUM14_H	R/W	H'0000 0000	H'24A4	8/16/32
DIGITAL NOISE FILTER NUMBER REGISTER15_L	FILNUM15_L	R/W	H'0000 0000	H'24A8	8/16/32
DIGITAL NOISE FILTER NUMBER REGISTER15_H	FILNUM15_H	R/W	H'0000 0000	H'24AC	8/16/32
DIGITAL NOISE FILTER NUMBER REGISTER16_L	FILNUM16_L	R/W	H'0000 0000	H'24B0	8/16/32
DIGITAL NOISE FILTER NUMBER REGISTER16_H	FILNUM16_H	R/W	H'0000 0000	H'24B4	8/16/32
DIGITAL NOISE FILTER NUMBER REGISTER17_L	FILNUM17_L	R/W	H'0000 0000	H'24B8	8/16/32
DIGITAL NOISE FILTER NUMBER REGISTER17_H	FILNUM17_H	R/W	H'0000 0000	H'24BC	8/16/32
DIGITAL NOISE FILTER NUMBER REGISTER18_L	FILNUM18_L	R/W	H'0000 0000	H'24C0	8/16/32
DIGITAL NOISE FILTER NUMBER REGISTER18_H	FILNUM18_H	R/W	H'0000 0000	H'24C4	8/16/32
DIGITAL NOISE FILTER NUMBER REGISTER19	FILNUM19	R/W	H'0000 0000	H'24C8	8/16/32
DIGITAL NOISE FILTER NUMBER REGISTER1A_L	FILNUM1A_L	R/W	H'0000 0000	H'24D0	8/16/32
DIGITAL NOISE FILTER NUMBER REGISTER1A_H	FILNUM1A_H	R/W	H'0000 0000	H'24D4	8/16/32
DIGITAL NOISE FILTER NUMBER REGISTER1B	FILNUM1B	R/W	H'0000 0000	H'24D8	8/16/32
DIGITAL NOISE FILTER NUMBER REGISTER1C	FILNUM1C	R/W	H'0000 0000	H'24E0	8/16/32
DIGITAL NOISE FILTER NUMBER REGISTER1D_L	FILNUM1D_L	R/W	H'0000 0000	H'24E8	8/16/32
DIGITAL NOISE FILTER NUMBER REGISTER1D_H	FILNUM1D_H	R/W	H'0000 0000	H'24EC	8/16/32
DIGITAL NOISE FILTER NUMBER REGISTER1E	FILNUM1E	R/W	H'0000 0000	H'24F0	8/16/32
DIGITAL NOISE FILTER NUMBER REGISTER1F	FILNUM1F	R/W	H'0000 0000	H'24F8	8/16/32
DIGITAL NOISE FILTER NUMBER REGISTER20	FILNUM20	R/W	H'0000 0000	H'2500	8/16/32
DIGITAL NOISE FILTER NUMBER REGISTER21	FILNUM21	R/W	H'0000 0000	H'2508	8/16/32
DIGITAL NOISE FILTER NUMBER REGISTER22_L	FILNUM22_L	R/W	H'0000 0000	H'2510	8/16/32
DIGITAL NOISE FILTER NUMBER REGISTER22_H	FILNUM22_H	R/W	H'0000 0000	H'2514	8/16/32

41.2.13 Digital Noise Filter Clock Selection Register (FILCLKSEL)

Register Name	Abbreviation	R/W	Initial Value	Address	Access Size
DIGITAL NOISE FILTER CLOCK SELECTION REGISTER 01	FILCLKSEL01	R/W	H'0000 0000	H'2808	8/16/32
DIGITAL NOISE FILTER CLOCK SELECTION REGISTER06	FILCLKSEL06	R/W	H'0000 0000	H'2830	8/16/32
DIGITAL NOISE FILTER CLOCK SELECTION REGISTER07	FILCLKSEL07	R/W	H'0000 0000	H'2838	8/16/32
DIGITAL NOISE FILTER CLOCK SELECTION REGISTER0B_L	FILCLKSEL0B_L	R/W	H'0000 0000	H'2858	8/16/32
DIGITAL NOISE FILTER CLOCK SELECTION REGISTER0B_H	FILCLKSEL0B_H	R/W	H'0000 0000	H'285C	8/16/32
DIGITAL NOISE FILTER CLOCK SELECTION REGISTER0C	FILCLKSEL0C	R/W	H'0000 0000	H'2860	8/16/32
DIGITAL NOISE FILTER CLOCK SELECTION REGISTER0F_L	FILCLKSEL0F_L	R/W	H'0000 0000	H'2878	8/16/32
DIGITAL NOISE FILTER CLOCK SELECTION REGISTER0F_H	FILCLKSEL0F_H	R/W	H'0000 0000	H'287C	8/16/32
DIGITAL NOISE FILTER CLOCK SELECTION REGISTER 10	FILCLKSEL10	R/W	H'0000 0000	H'2880	8/16/32
DIGITAL NOISE FILTER CLOCK SELECTION REGISTER11_L	FILCLKSEL11_L	R/W	H'0000 0000	H'2888	8/16/32
DIGITAL NOISE FILTER CLOCK SELECTION REGISTER11_H	FILCLKSEL11_H	R/W	H'0000 0000	H'288C	8/16/32
DIGITAL NOISE FILTER CLOCK SELECTION REGISTER12	FILCLKSEL12	R/W	H'0000 0000	H'2890	8/16/32
DIGITAL NOISE FILTER CLOCK SELECTION REGISTER13	FILCLKSEL13	R/W	H'0000 0000	H'2898	8/16/32
DIGITAL NOISE FILTER CLOCK SELECTION REGISTER14_L	FILCLKSEL14_L	R/W	H'0000 0000	H'28A0	8/16/32
DIGITAL NOISE FILTER CLOCK SELECTION REGISTER14_H	FILCLKSEL14_H	R/W	H'0000 0000	H'28A4	8/16/32
DIGITAL NOISE FILTER CLOCK SELECTION REGISTER15_L	FILCLKSEL15_L	R/W	H'0000 0000	H'28A8	8/16/32
DIGITAL NOISE FILTER CLOCK SELECTION REGISTER15_H	FILCLKSEL15_H	R/W	H'0000 0000	H'28AC	8/16/32
DIGITAL NOISE FILTER CLOCK SELECTION REGISTER16_L	FILCLKSEL16_L	R/W	H'0000 0000	H'28B0	8/16/32
DIGITAL NOISE FILTER CLOCK SELECTION REGISTER16_H	FILCLKSEL16_H	R/W	H'0000 0000	H'28B4	8/16/32
DIGITAL NOISE FILTER CLOCK SELECTION REGISTER17_L	FILCLKSEL17_L	R/W	H'0000 0000	H'28B8	8/16/32
DIGITAL NOISE FILTER CLOCK SELECTION REGISTER17_H	FILCLKSEL17_H	R/W	H'0000 0000	H'28BC	8/16/32
DIGITAL NOISE FILTER CLOCK SELECTION REGISTER18_L	FILCLKSEL18_L	R/W	H'0000 0000	H'28C0	8/16/32
DIGITAL NOISE FILTER CLOCK SELECTION REGISTER18_H	FILCLKSEL18_H	R/W	H'0000 0000	H'28C4	8/16/32
DIGITAL NOISE FILTER CLOCK SELECTION REGISTER19	FILCLKSEL19	R/W	H'0000 0000	H'28C8	8/16/32
DIGITAL NOISE FILTER CLOCK SELECTION REGISTER1A_L	FILCLKSEL1A_L	R/W	H'0000 0000	H'28D0	8/16/32
DIGITAL NOISE FILTER CLOCK SELECTION REGISTER1A_H	FILCLKSEL1A_H	R/W	H'0000 0000	H'28D4	8/16/32

Register Name	Abbreviation	R/W	Initial Value	Address	Access Size
DIGITAL NOISE FILTER CLOCK SELECTION REGISTER1B	FILCLKSEL1B	R/W	H'0000 0000	H'28D8	8/16/32
DIGITAL NOISE FILTER CLOCK SELECTION REGISTER1C	FILCLKSEL1C	R/W	H'0000 0000	H'28E0	8/16/32
DIGITAL NOISE FILTER CLOCK SELECTION REGISTER1D_L	FILCLKSEL1D_L	R/W	H'0000 0000	H'28E8	8/16/32
DIGITAL NOISE FILTER CLOCK SELECTION REGISTER1D_H	FILCLKSEL1D_H	R/W	H'0000 0000	H'28EC	8/16/32
DIGITAL NOISE FILTER CLOCK SELECTION REGISTER1E	FILCLKSEL1E	R/W	H'0000 0000	H'28F0	8/16/32
DIGITAL NOISE FILTER CLOCK SELECTION REGISTER1F	FILCLKSEL1F	R/W	H'0000 0000	H'28F8	8/16/32
DIGITAL NOISE FILTER CLOCK SELECTION REGISTER20	FILCLKSEL20	R/W	H'0000 0000	H'2900	8/16/32
DIGITAL NOISE FILTER CLOCK SELECTION REGISTER21	FILCLKSEL21	R/W	H'0000 0000	H'2908	8/16/32
DIGITAL NOISE FILTER CLOCK SELECTION REGISTER22_L	FILCLKSEL22_L	R/W	H'0000 0000	H'2910	8/16/32
DIGITAL NOISE FILTER CLOCK SELECTION REGISTER22_H	FILCLKSEL22_H	R/W	H'0000 0000	H'2914	8/16/32

41.2.14 Ether ch0 IO Voltage Mode Control Register (ETH_ch0)

Register Name	Abbreviation	R/W	Initial Value	Address	Access Size
ETHER CH0 IO VOLTAGE MODE CONTROL REGISTER	ETH_ch0	R/W	H'0000 0000	H'300C	8/16/32

41.2.15 Ether ch1 IO Voltage Mode Control Register (ETH_ch1)

Register Name	Abbreviation	R/W	Initial Value	Address	Access Size
ETHER CH1 IO VOLTAGE MODE CONTROL REGISTER	ETH_ch1	R/W	H'0000 0000	H'3010	8/16/32

41.2.16 Ether MII/RGMII Mode Control Register (ETH MII/RGMII)

Register Name	Abbreviation	R/W	Initial Value	Address	Access Size
ETHER MII/RGMII MODE CONTROL REGISTER	ETH MII/RGMII	R/W	H'0000 0003	H'3018	8/16/32

41.2.17 SD ch0 IO Voltage Mode Control Register (SD_ch0)

Register Name	Abbreviation	R/W	Initial Value	Address	Access Size
SD CH0 IO VOLTAGE MODE CONTROL REGISTER	SD_ch0	R/W	*1	H'3000	8/16/32

Note 1. For the initial value, refer to **Section 41.3.17, SD ch0 IO Voltage Mode Control Register (SD_ch0)**.

41.2.18 SD ch1 IO Voltage Mode Control Register (SD_ch1)

Register Name	Abbreviation	R/W	Initial Value	Address	Access Size
SD CH1 IO VOLTAGE MODE CONTROL REGISTER	SD_ch1	R/W	H'00	H'3004	8/16/32

41.2.19 QSPI IO Voltage Mode Control Register (QSPI)

Register Name	Abbreviation	R/W	Initial Value	Address	Access Size
QSPI IO VOLTAGE MODE CONTROL REGISTER	QSPI	R/W	*1	H'3008	8/16/32

Note 1. For the initial value, refer to **Section 41.3.19, QSPI IO Voltage Mode Control Register (QSPI)**.

41.2.20 Input Enable Control Register (IEN)

Register Name	Abbreviation	R/W	Initial Value	Address	Access Size
INPUT ENABLE CONTROL REGISTER02	IEN02	R/W	H'0000 0000	H1810	8/16/32
INPUT ENABLE CONTROL REGISTER04	IEN04	R/W	H'0000 0000	H1820	8/16/32
INPUT ENABLE CONTROL REGISTER06	IEN06	R/W	H'0000 0000	H1830	8/16/32
INPUT ENABLE CONTROL REGISTER07_L	IEN07_L	R/W	H'0000 0000	H1838	8/16/32
INPUT ENABLE CONTROL REGISTER07_H	IEN07_H	R/W	H'0000 0000	H183C	8/16/32
INPUT ENABLE CONTROL REGISTER08	IEN08	R/W	H'0000 0000	H1840	8/16/32
INPUT ENABLE CONTROL REGISTER09	IEN09	R/W	H'0000 0000	H1848	8/16/32
INPUT ENABLE CONTROL REGISTER0E	IEN0E	R/W	H'0000 0000	H1870	8/16/32

41.3 Register Descriptions

41.3.1 Port Register (Pn)

The Pn register sets the GPIO output value.

For the offset address, refer to **Section 41.2.1, Port Register (Pn)**.

Bit	7	6	5	4	3	2	1	0
	P7	P6	P5	P4	P3	P2	P1	P0
Initial Value	0	0	0	0	0	0	0	0
R/W	R/W	R/W	R/W	R/W	R/W	R/W	R/W	R/W

Bit	Bit Name	Initial Value	R/W	Description
7	P7	0b	R/W	These bits set the value of the GPIO pin. (P7 to P0) 0b: Low is output. 1b: High is output. Please refer to the table below for the correspondence of each terminal.
6	P6	0b	R/W	
5	P5	0b	R/W	
4	P4	0b	R/W	
3	P3	0b	R/W	
2	P2	0b	R/W	
1	P1	0b	R/W	
0	P0	0b	R/W	

Table 41.1 Correspondence between register and each terminal (1/2)

Bit Name	bit7	bit6	bit5	bit4	bit3	bit2	bit1	bit0
P06	—	—	—	—	—	0*1	P19_1	0*1
P07	P20_7	P20_6	P20_5	P20_4	P20_3	P20_2	P20_1	P20_0
P08	—	—	—	—	—	—	P21_1	0*1
P09	—	—	—	—	P22_3	P22_2	P22_1	P22_0
P0A	—	—	P23_5	P23_4	P23_3	P23_2	P23_1	0*1
P0B	—	—	P24_5	P24_4	P24_3	P24_2	P24_1	P24_0
P0C	—	—	—	—	—	—	P25_1	0*1
P0F	—	—	P28_5	P28_4	P28_3	P28_2	P28_1	P28_0
P10	—	—	—	—	P0_3	P0_2	P0_1	P0_0
P11	—	—	—	P1_4	P1_3	P1_2	P1_1	P1_0
P12	—	—	—	—	P2_3	P2_2	P2_1	P2_0
P13	—	—	—	—	P3_3	P3_2	P3_1	P3_0
P14	—	—	P4_5	P4_4	P4_3	P4_2	P4_1	P4_0
P15	—	—	—	P5_4	P5_3	P5_2	P5_1	P5_0
P16	—	—	—	P6_4	P6_3	P6_2	P6_1	P6_0
P17	—	—	—	P7_4	P7_3	P7_2	P7_1	P7_0
P18	—	—	—	P8_4	P8_3	P8_2	P8_1	P8_0
P19	—	—	—	—	P9_3	P9_2	P9_1	P9_0
P1A	—	—	—	P10_4	P10_3	P10_2	P10_1	P10_0
P1B	—	—	—	—	P11_3	P11_2	P11_1	P11_0
P1C	—	—	—	—	—	—	P12_1	P12_0
P1D	—	—	—	P13_4	P13_3	P13_2	P13_1	P13_0

Table 41.1 Correspondence between register and each terminal (2/2)

Bit Name	bit7	bit6	bit5	bit4	bit3	bit2	bit1	bit0
P1E	—	—	—	—	—	P14_2	P14_1	P14_0
P1F	—	—	—	—	P15_3	P15_2	P15_1	P15_0
P20	—	—	—	—	—	—	P16_1	P16_0
P21	—	—	—	—	P17_3	P17_2	P17_1	P17_0
P22	—	—	P18_5	P18_4	P18_3	P18_2	P18_1	P18_0

Note 1. When read, the initial value is read. The written value will be ignored.

41.3.2 Port Mode Register (PMn)

The PMn register sets input/output of GPIO.

For the offset address, refer to **Section 41.2.2, Port Mode Register (PMn)**.

Bit	15	14	13	12	11	10	9	8	7	6	5	4	3	2	1	0
	PM7		PM6		PM5		PM4		PM3		PM2		PM1		PM0	
Initial Value	0	0	0	0	0	0	0	0	0	0	0	0	0	0	0	0
	R/W	R/W	R/W	R/W	R/W	R/W	R/W	R/W	R/W	R/W	R/W	R/W	R/W	R/W	R/W	R/W

Bit	Bit Name	Initial Value	R/W	Description
15, 14	PM7	00b	R/W	These bits set input/output of the GPIO pin. (PM7 to PM0) 00b: Hi-Z (Initial Value)
13, 12	PM6	00b	R/W	
11, 10	PM5	00b	R/W	01b: Input Mode
9, 8	PM4	00b	R/W	10b: Output Mode (Input Disable)
7, 6	PM3	00b	R/W	11b: Output Mode (Input Enable)
5, 4	PM2	00b	R/W	Please refer to the table below for the correspondence of each terminal.
3, 2	PM1	00b	R/W	
1, 0	PM0	00b	R/W	

Table 41.2 Correspondence between register and each terminal (1/2)

Bit Name	bit15-14	bit13-12	bit11-10	bit9-8	bit7-6	bit5-4	bit3-2	bit1-0
PM06	—	—	—	—	—	2'b00*1	P19_1	2'b00*1
PM07	P20_7	P20_6	P20_5	P20_4	P20_3	P20_2	P20_1	P20_0
PM08	—	—	—	—	—	—	P21_1	2'b00*1
PM09	—	—	—	—	P22_3	P22_2	P22_1	P22_0
PM0A	—	—	P23_5	P23_4	P23_3	P23_2	P23_1	2'b00*1
PM0B	—	—	P24_5	P24_4	P24_3	P24_2	P24_1	P24_0
PM0C	—	—	—	—	—	—	P25_1	2'b00*1
PM0F	—	—	P28_5	P28_4	P28_3	P28_2	P28_1	P28_0
PM10	—	—	—	—	P0_3	P0_2	P0_1	P0_0
PM11	—	—	—	P1_4	P1_3	P1_2	P1_1	P1_0
PM12	—	—	—	—	P2_3	P2_2	P2_1	P2_0
PM13	—	—	—	—	P3_3	P3_2	P3_1	P3_0
PM14	—	—	P4_5	P4_4	P4_3	P4_2	P4_1	P4_0
PM15	—	—	—	P5_4	P5_3	P5_2	P5_1	P5_0
PM16	—	—	—	P6_4	P6_3	P6_2	P6_1	P6_0
PM17	—	—	—	P7_4	P7_3	P7_2	P7_1	P7_0
PM18	—	—	—	P8_4	P8_3	P8_2	P8_1	P8_0
PM19	—	—	—	—	P9_3	P9_2	P9_1	P9_0
PM1A	—	—	—	P10_4	P10_3	P10_2	P10_1	P10_0
PM1B	—	—	—	—	P11_3	P11_2	P11_1	P11_0
PM1C	—	—	—	—	—	—	P12_1	P12_0
PM1D	—	—	—	P13_4	P13_3	P13_2	P13_1	P13_0
PMC1E	—	—	—	—	—	P14_2	P14_1	P14_0
PMC1F	—	—	—	—	P15_3	P15_2	P15_1	P15_0

Table 41.2 Correspondence between register and each terminal (2/2)

Bit Name	bit15-14	bit13-12	bit11-10	bit9-8	bit7-6	bit5-4	bit3-2	bit1-0
PMC20	—	—	—	—	—	—	P16_1	P16_0
PMC21	—	—	—	—	P17_3	P17_2	P17_1	P17_0
PMC22	—	—	P18_5	P18_4	P18_3	P18_2	P18_1	P18_0

Note 1. When read, the initial value is read. The written value will be ignored.

41.3.3 Port Mode Control Register (PMcN)

The PMcN register switches the mode for the multiplexed pins of GPIO.

For the offset address, refer to **Section 41.2.3, Port Mode Control Register (PMcN)**.

Bit	7	6	5	4	3	2	1	0
	PMC7	PMC6	PMC5	PMC4	PMC3	PMC2	PMC1	PMC0
Initial Value	0	0	0	0	0	0	0	0
	R/W	R/W	R/W	R/W	R/W	R/W	R/W	R/W

Bit	Bit Name	Initial Value	R/W	Description
7	PMC7	0b	R/W	These bits switch the mode for the multiplexed pin of the GPIO pin. (PMC7 to PMC0) 0b: Port Mode (GPIO) 1b: Peripheral Function Mode (Peripheral Function) Please refer to the table below for the correspondence of each terminal.
6	PMC6	0b	R/W	
5	PMC5	0b	R/W	
4	PMC4	0b	R/W	
3	PMC3	0b	R/W	
2	PMC2	0b	R/W	
1	PMC1	0b	R/W	
0	PMC0	0b	R/W	

Table 41.3 Correspondence between register and each terminal (1/2)

Bit Name	bit7	bit6	bit5	bit4	bit3	bit2	bit1	bit0
PMC06	—	—	—	—	—	1*1	P19_1*2	1*1
PMC07	P20_7*2	P20_6*2	P20_5*2	P20_4*2	P20_3*2	P20_2*2	P20_1*2	P20_0*2
PMC08	—	—	—	—	—	—	P21_1*2	1*1
PMC09	—	—	—	—	P22_3*2	P22_2*2	P22_1*2	P22_0*2
PMC0A	—	—	P23_5*3	P23_4*3	P23_3*3	P23_2*3	P23_1*3	1*1
PMC0B	—	—	P24_5*3	P24_4*3	P24_3*3	P24_2*3	P24_1*3	P24_0*3
PMC0C	—	—	—	—	—	—	P25_1*3	1*1
PMC0F	—	—	P28_5*4	P28_4*4	P28_3*4	P28_2*4	P28_1*4	P28_0*4
PMC10	—	—	—	—	P0_3	P0_2	P0_1	P0_0
PMC11	—	—	—	P1_4	P1_3	P1_2	P1_1	P1_0
PMC12	—	—	—	—	P2_3	P2_2	P2_1	P2_0
PMC13	—	—	—	—	P3_3	P3_2	P3_1	P3_0
PMC14	—	—	P4_5	P4_4	P4_3	P4_2	P4_1	P4_0
PMC15	—	—	—	P5_4	P5_3	P5_2	P5_1	P5_0
PMC16	—	—	—	P6_4	P6_3	P6_2	P6_1	P6_0
PMC17	—	—	—	P7_4	P7_3	P7_2	P7_1	P7_0
PMC18	—	—	—	P8_4	P8_3	P8_2	P8_1	P8_0
PMC19	—	—	—	—	P9_3	P9_2	P9_1	P9_0
PMC1A	—	—	—	P10_4	P10_3	P10_2	P10_1	P10_0
PMC1B	—	—	—	—	P11_3	P11_2	P11_1	P11_0
PMC1C	—	—	—	—	—	—	P12_1	P12_0
PMC1D	—	—	—	P13_4	P13_3	P13_2	P13_1	P13_0
PMC1E	—	—	—	—	—	P14_2	P14_1	P14_0
PMC1F	—	—	—	—	P15_3	P15_2	P15_1	P15_0

Table 41.3 Correspondence between register and each terminal (2/2)

Bit Name	bit15-14	bit13-12	bit11-10	bit9-8	bit7-6	bit5-4	bit3-2	bit1-0
PMC20	—	—	—	—	—	—	P16_1	P16_0
PMC21	—	—	—	—	P17_3	P17_2	P17_1	P17_0
PMC22	—	—	P18_5	P18_4	P18_3	P18_2	P18_1	P18_0

Note 1. When read, the initial value is read. The written value will be ignored.

Note 2. When Boot Mode 0, 1 or 2 is selected (MD_BOOT[2:0] = 000b, 001b or 010b), these bits are fixed to 1.

Note 3. When Boot Mode 3 or 4 is selected (MD_BOOT[2:0] = 011b or 100b), these bits are fixed to 1.

Note 4. These bits are set to 1 after reset.

41.3.4 Port Function Control Register (PFCm)

The PFCm register sets multiplexed functions.

This register can be write-protected by the PWPR register.

For the offset address, refer to **Section 41.2.4, Port Function Control Register (PFCm)**.

Bit	31	30	29	28	27	26	25	24	23	22	21	20	19	18	17	16
	—	PFC7			—	PFC6			—	PFC5			—	PFC4		
Initial Value	—	0	0	0	—	0	0	0	—	0	0	0	—	0	0	0
R/W	R	R/W	R/W	R/W	R	R/W	R/W	R/W	R	R/W	R/W	R/W	R	R/W	R/W	R/W
Bit	15	14	13	12	11	10	9	8	7	6	5	4	3	2	1	0
	—	PFC3			—	PFC2			—	PFC1			—	PFC0		
Initial Value	0	0	0	0	0	0	0	0	0	0	0	0	0	0	0	0
R/W	R	R/W	R/W	R/W	R	R/W	R/W	R/W	R	R/W	R/W	R/W	R	R/W	R/W	R/W

Bit	Bit Name	Initial Value	R/W	Description
31, 27, 23, 19, 15, 11, 7, 3	—	—	R	Reserved When read, the initial value is read. The written value will be ignored.
30 to 28	PFC7	000b	R/W	These bits set the multiplexed function of the GPIO pin. (PFC7 to PFC0) 000b: Function0 (Initial value) 001b: Function1 010b: Function2 011b: Function3 100b: Function4 101b: Function5 110b: Function6 111b: Function7 Please refer to the table below for the correspondence of each terminal.
26 to 24	PFC6	000b	R/W	
22 to 20	PFC5	000b	R/W	
18 to 16	PFC4	000b	R/W	
14 to 12	PFC3	000b	R/W	
10 to 8	PFC2	000b	R/W	
6 to 4	PFC1	000b	R/W	
2 to 0	PFC0	000b	R/W	

Note: Please refer to “Pin function list” for the function of Function (0 to 5).

Table 41.4 Correspondence between register and each terminal (1/2)

Bit Name	bit30-28	bit26-24	bit22-20	bit18-16	bit14-12	bit10-8	bit6-4	bit2-0
PFC06	—	—	—	—	—	—	P19_1*1	—
PFC07	P20_7*1	P20_6*1	P20_5*1	P20_4*1	P20_3*1	P20_2*1	P20_1*1	P20_0*1
PFC08	—	—	—	—	—	—	P21_1*1	—
PFC09	—	—	—	—	P22_3*1	P22_2*1	P22_1*1	P22_0*1
PFC0A	—	—	P23_5*2	P23_4*2	P23_3*2	P23_2*2	P23_1*2	-
PFC0B	—	—	P24_5*2	P24_4*2	P24_3*2	P24_2*2	P24_1*2	P24_0*2
PFC0C	—	—	—	—	—	—	P25_1*2	—
PFC0F	—	—	P28_5	P28_4	P28_3	P28_2	P28_1	P28_0
PFC10	—	—	—	—	P0_3	P0_2	P0_1	P0_0
PFC11	—	—	—	P1_4	P1_3	P1_2	P1_1	P1_0
PFC12	—	—	—	—	P2_3	P2_2	P2_1	P2_0
PFC13	—	—	—	—	P3_3	P3_2	P3_1	P3_0
PFC14	—	—	P4_5	P4_4	P4_3	P4_2	P4_1	P4_0

Table 41.4 Correspondence between register and each terminal (2/2)

Bit Name	bit30-28	bit26-24	bit22-20	bit18-16	bit14-12	bit10-8	bit6-4	bit2-0
PFC15	—	—	—	P5_4	P5_3	P5_2	P5_1	P5_0
PFC16	—	—	—	P6_4	P6_3	P6_2	P6_1	P6_0
PFC17	—	—	—	P7_4	P7_3	P7_2	P7_1	P7_0
PFC18	—	—	—	P8_4	P8_3	P8_2	P8_1	P8_0
PFC19	—	—	—	—	P9_3	P9_2	P9_1	P9_0
PFC1A	—	—	—	P10_4	P10_3	P10_2	P10_1	P10_0
PFC1B	—	—	—	—	P11_3	P11_2	P11_1	P11_0
PFC1C	—	—	—	—	—	—	P12_1	P12_0
PFC1D	—	—	—	P13_4	P13_3	P13_2	P13_1	P13_0
PFC1E	—	—	—	—	—	P14_2	P14_1	P14_0
PFC1F	—	—	—	—	P15_3	P15_2	P15_1	P15_0
PFC20	—	—	—	—	—	—	P16_1	P16_0
PFC21	—	—	—	—	P17_3	P17_2	P17_1	P17_0
PFC22	—	—	P18_5	P18_4	P18_3	P18_2	P18_1	P18_0

Note 1. When Boot Mode 0, 1 or 2 is selected (MD_BOOT[2:0] = 000b, 001b or 010b), these bits are fixed to 0.

Note 2. When Boot Mode 3 or 4 is selected (MD_BOOT[2:0] = 011b or 100b), these bits are fixed to 0.

41.3.5 Port Input Register (PINn)

The PINn register is a read-only register to monitor input values of input pins.

For the offset address, refer to **Section 41.2.5, Port Input Register (PINn)**.

Bit	7	6	5	4	3	2	1	0
	PIN7	PIN6	PIN5	PIN4	PIN3	PIN2	PIN1	PIN0
Initial Value	0	0	0	0	0	0	0	0
R/W	R	R	R	R	R	R	R	R

Bit	Bit Name	Initial Value	R/W	Description
7	PIN7	0b	R	Input value of the input pin (PIN7 to PIN0)
6	PIN6	0b	R	Please refer to the table below for the correspondence of each terminal.
5	PIN5	0b	R	
4	PIN4	0b	R	
3	PIN3	0b	R	
2	PIN2	0b	R	
1	PIN1	0b	R	
0	PIN0	0b	R	

Table 41.5 Correspondence between register and each terminal (1/2)

Bit Name	bit7	bit6	bit5	bit4	bit3	bit2	bit1	bit0
PIN06	—	—	—	—	—	—	P19_1	—
PIN07	P20_7	P20_6	P20_5	P20_4	P20_3	P20_2	P20_1	P20_0
PIN08	—	—	—	—	—	—	P21_1	—
PIN09	—	—	—	—	P22_3	P22_2	P22_1	P22_0
PIN0A	—	—	P23_5	P23_4	P23_3	P23_2	P23_1	—
PIN0B	—	—	P24_5	P24_4	P24_3	P24_2	P24_1	P24_0
PIN0C	—	—	—	—	—	—	P25_1	—
PIN0F	—	—	P28_5	P28_4	P28_3	P28_2	P28_1	P28_0
PIN10	—	—	—	—	P0_3	P0_2	P0_1	P0_0
PIN11	—	—	—	P1_4	P1_3	P1_2	P1_1	P1_0
PIN12	—	—	—	—	P2_3	P2_2	P2_1	P2_0
PIN13	—	—	—	—	P3_3	P3_2	P3_1	P3_0
PIN14	—	—	P4_5	P4_4	P4_3	P4_2	P4_1	P4_0
PIN15	—	—	—	P5_4	P5_3	P5_2	P5_1	P5_0
PIN16	—	—	—	P6_4	P6_3	P6_2	P6_1	P6_0
PIN17	—	—	—	P7_4	P7_3	P7_2	P7_1	P7_0
PIN18	—	—	—	P8_4	P8_3	P8_2	P8_1	P8_0
PIN19	—	—	—	—	P9_3	P9_2	P9_1	P9_0
PIN1A	—	—	—	P10_4	P10_3	P10_2	P10_1	P10_0
PIN1B	—	—	—	—	P11_3	P11_2	P11_1	P11_0
PIN1C	—	—	—	—	—	—	P12_1	P12_0
PIN1D	—	—	—	P13_4	P13_3	P13_2	P13_1	P13_0
PIN1E	—	—	—	—	—	P14_2	P14_1	P14_0
PIN1F	—	—	—	—	P15_3	P15_2	P15_1	P15_0

Table 41.5 Correspondence between register and each terminal (2/2)

Bit Name	bit7	bit6	bit5	bit4	bit3	bit2	bit1	bit0
PIN20	—	—	—	—	—	—	P16_1	P16_0
PIN21	—	—	—	—	P17_3	P17_2	P17_1	P17_0
PIN22	—	—	P18_5	P18_4	P18_3	P18_2	P18_1	P18_0

41.3.6 Interrupt Enable Control Register (ISEL)

The ISEL register controls whether to enable or disable interrupts.

The pin set as the GPIO input port can be used as an external interrupt input. Controls whether this feature is enabled or disabled. When enabled, this pin can be used as an interrupt by setting the interrupt controller.

For the offset address, refer to **Section 41.2.6, Interrupt Enable Control Register (ISEL)**.

Bit	31	30	29	28	27	26	25	24	23	22	21	20	19	18	17	16
	—	—	—	—	—	—	—	ISEL3	—	—	—	—	—	—	—	ISEL2
Initial Value	—	—	—	—	—	—	—	0	—	—	—	—	—	—	—	0
R/W	R	R	R	R	R	R	R	R/W	R	R	R	R	R	R	R	R/W
Bit	15	14	13	12	11	10	9	8	7	6	5	4	3	2	1	0
	—	—	—	—	—	—	—	ISEL1	—	—	—	—	—	—	—	ISEL0
Initial Value	—	—	—	—	—	—	—	0	—	—	—	—	—	—	—	0
R/W	R	R	R	R	R	R	R	R/W	R	R	R	R	R	R	R	R/W

Bit	Bit Name	Initial Value	R/W	Description
31 to 25, 23 to 17, 15 to 9, 7 to 1	—	—	R	Reserved When read, the initial value is read. The written value will be ignored.
24	ISEL3	0b	R/W	The ISEL register controls whether to enable or disable interrupts.
16	ISEL2	0b	R/W	0b: Disabled (Initial value) 1b: Enabled
8	ISEL1	0b	R/W	Please refer to the table below for the correspondence of each terminal.
0	ISEL0	0b	R/W	

Note: Before setting this register, disable interrupt detection in the Interrupt Controller.
If PMCN bit = 1, ISEL bit = 1 is prohibited.

Table 41.6 Correspondence between register and each terminal (1/2)

Bit Name	bit24	bit16	bit8	bit0
ISEL10	P0_3	P0_2	P0_1	P0_0
ISEL11_L	P1_3	P1_2	P1_1	P1_0
ISEL11_H	—	—	—	P1_4
ISEL12	P2_3	P2_2	P2_1	P2_0
ISEL13	P3_3	P3_2	P3_1	P3_0
ISEL14_L	P4_3	P4_2	P4_1	P4_0
ISEL14_H	—	—	P4_5	P4_4
ISEL15_L	P5_3	P5_2	P5_1	P5_0
ISEL15_H	—	—	—	P5_4
ISEL16_L	P6_3	P6_2	P6_1	P6_0
ISEL16_H	—	—	—	P6_4
ISEL17_L	P7_3	P7_2	P7_1	P7_0
ISEL17_H	—	—	—	P7_4
ISEL18_L	P8_3	P8_2	P8_1	P8_0
ISEL18_H	—	—	—	P8_4

Table 41.6 Correspondence between register and each terminal (2/2)

Bit Name	bit24	bit16	bit8	bit0
ISEL19	P9_3	P9_2	P9_1	P9_0
ISEL1A_L	P10_3	P10_2	P10_1	P10_0
ISEL1A_H	—	—	—	P10_4
ISEL1B	P11_3	P11_2	P11_1	P11_0
ISEL1C	—	—	P12_1	P12_0
ISEL1D_L	P13_3	P13_2	P13_1	P13_0
ISEL1D_H	—	—	—	P13_4
ISEL1E	—	P14_2	P14_1	P14_0
ISEL1F	P15_3	P15_2	P15_1	P15_0
ISEL20	—	—	P16_1	P16_0
ISEL21	P17_3	P17_2	P17_1	P17_0
ISEL22_L	P18_3	P18_2	P18_1	P18_0
ISEL22_H	—	—	P18_5	P18_4

41.3.7 Driving Ability Control Register (IOLH)

This register sets the buffer drive ability of GPIO and Special Purpose Port.

For the offset address, refer to **Section 41.2.7, Driving Ability Control Register (IOLH)**.

Bit	31	30	29	28	27	26	25	24	23	22	21	20	19	18	17	16
	—	—	—	—	—	—	IOLH3		—	—	—	—	—	—	IOLH2	
Initial Value	—	—	—	—	—	—	*1	*1	—	—	—	—	—	—	*1	*1
R/W	R	R	R	R	R	R	R/W	R/W	R	R	R	R	R	R	R/W	R/W
Bit	15	14	13	12	11	10	9	8	7	6	5	4	3	2	1	0
	—	—	—	—	—	—	IOLH1		—	—	—	—	—	—	IOLH0	
Initial Value	—	—	—	—	—	—	*1	*1	—	—	—	—	—	—	*1	*1
R/W	R	R	R	R	R	R	R/W	R/W	R	R	R	R	R	R	R/W	R/W

Bit	Bit Name	Initial Value	R/W	Description								
31 to 26, 23 to 18, 15 to 10, 7 to 2	—	—	R	Reserved When read, the initial value is read. The written value will be ignored.								
25, 24	IOLH3	*1	R/W	These bits set the drive Ability of each pin. (IOLH7 to IOLH0)								
17, 16	IOLH2	*1	R/W									
9, 8	IOLH1	*1	R/W									
1, 0	IOLH0	*1	R/W									
											Pin Group-B	
											Cload	
					Register Value	Pin Group-A	Register Value	3.3 V	1.8 V	Output Impedance		
					00b	2 mA	00b	5 pF	5 pF	× 0.5 = 100Ω		
					01b (Initial Value)	4 mA	01b	12 pF	11 pF	× 0.75 = 66Ω		
					10b	8 mA	10b (Initial Value)	26 pF	15 pF	× 1.0 = 50Ω		
					11b	12 mA	11b	40 pF	21 pF	× 1.5 = 33Ω		

Note 1. Refer to the above value for Initial Value.
Please refer to the table below for the correspondence of each pin (including Pin Group).

Table 41.7 Correspondence between register and each terminal (1/2)

Bit Name	bit25-24	bit17-16	bit9-8	bit1-0	Pin Group
IOLH02	—	—	—	TMS/SWDIO	A
IOLH03	—	—	—	TDO	A
IOLH06	—	SD0_RST#	P19_1	SD0_CLK	B
IOLH07_L	P20_3	P20_2	P20_1	P20_0	B
IOLH07_H	P20_7	P20_6	P20_5	P20_4	B
IOLH08	—	—	P21_1	SD1_CLK	B
IOLH09	P22_3	P22_2	P22_1	P22_0	B
IOLH0A_L	P23_3	P23_2	P23_1	QSPIO_SPCLK	B
IOLH0A_H	—	—	P23_5	P23_4	B
IOLH0B_L	P24_3	P24_2	P24_1	P24_0	B
IOLH0B_H	—	—	P24_5	P24_4	B
IOLH0C	—	—	P25_1	QSPIO_RESET#	B
IOLH0F_L	P28_3	P28_2	P28_1	P28_0	A
IOLH0F_H	—	—	P28_5	P28_4	A

Table 41.7 Correspondence between register and each terminal (2/2)

Bit Name	bit25-24	bit17-16	bit9-8	bit1-0	Pin Group
IOLH10	P0_3	P0_2	P0_1	P0_0	A
IOLH15_L	P5_3	P5_2	P5_1	P5_0	A
IOLH15_H	—	—	—	P5_4	A
IOLH16_L	P6_3	P6_2	P6_1	P6_0	A
IOLH16_H	—	—	—	P6_4	A
IOLH1B	P11_3	P11_2	P11_1	P11_0	A
IOLH1C	—	—	P12_1	P12_0	A
IOLH1D_L	P13_3	P13_2	P13_1	P13_0	A
IOLH1D_H	—	—	—	P13_4	A
IOLH1E	—	P14_2	P14_1	P14_0	A
IOLH1F	P15_3	P15_2	P15_1	P15_0	A
IOLH20	—	—	P16_1	P16_0	A
IOLH21	P17_3	P17_2	P17_1	P17_0	A
IOLH22_L	P18_3	P18_2	P18_1	P18_0	A
IOLH22_H	—	—	P18_5	P18_4	A

41.3.8 Slew Rate Switching Register (SR)

The SR register sets the slew rate of the GPIO pins and Special purpose pins.

For the offset address, refer to **Section 41.2.8, Slew Rate Switching Register (SR)**.

Bit	31	30	29	28	27	26	25	24	23	22	21	20	19	18	17	16
	—	—	—	—	—	—	—	SR3	—	—	—	—	—	—	—	SR2
Initial Value	—	—	—	—	—	—	—	1	—	—	—	—	—	—	—	1
R/W	R	R	R	R	R	R	R	R/W	R	R	R	R	R	R	R	R/W
Bit	15	14	13	12	11	10	9	8	7	6	5	4	3	2	1	0
	—	—	—	—	—	—	—	SR1	—	—	—	—	—	—	—	SR0
Initial Value	—	—	—	—	—	—	—	1	—	—	—	—	—	—	—	1
R/W	R	R	R	R	R	R	R	R/W	R	R	R	R	R	R	R	R/W

Bit	Bit Name	Initial Value	R/W	Description
31 to 25, 23 to 17, 15 to 9, 7 to 1	—	—	R	Reserved When read, the initial value is read. The written value will be ignored.
24	SR3	1b	R/W	These bits control the slew rate of each pin (SR7 to SR0) 0b: Slow 1b: Fast (Initial value) Please refer to the table below for the correspondence of each terminal.
16	SR2	1b	R/W	
8	SR1	1b	R/W	
0	SR0	1b	R/W	

Note: The WDTOVF_PERROUT# bit (H'1468 bit 0) in the SR register is reset by the assertion of the RST_WDTOVFN signal from the CPG.

Table 41.8 Correspondence between register and each terminal (1/2)

Bit Name	bit24	bit16	bit8	bit0
SR02	—	—	—	TMS/SWDIO
SR03	—	—	—	TDO
SR06	—	SD0_RST#	P19_1	SD0_CLK
SR07_L	P20_3	P20_2	P20_1	P20_0
SR07_H	P20_7	P20_6	P20_5	P20_4
SR08	—	—	P21_1	SD1_CLK
SR09	P22_3	P22_2	P22_1	P22_0
SR0A_L	P23_3	P23_2	P23_1	QSPIO_SPCLK
SR0A_H	—	—	P23_5	P23_4
SR0B_L	P24_3	P24_2	P24_1	P24_0
SR0B_H	—	—	P24_5	P24_4
SR0C	—	—	P25_1	QSPIO_RESET#
SR0F_L	P28_3	P28_2	P28_1	P28_0
SR0F_H	—	—	P28_5	P28_4
SR10	P0_3	P0_2	P0_1	P0_0
SR15_L	P5_3	P5_2	P5_1	P5_0
SR15_H	—	—	—	P5_4
SR16_L	P6_3	P6_2	P6_1	P6_0

Table 41.8 Correspondence between register and each terminal (2/2)

Bit Name	bit24	bit16	bit8	bit0
SR16_H	—	—	—	P6_4
SR1B	P11_3	P11_2	P11_1	P11_0
SR1C	—	—	P12_1	P12_0
SR1D_L	P13_3	P13_2	P13_1	P13_0
SR1D_H	—	—	—	P13_4
SR1E	—	P14_2	P14_1	P14_0
SR1F	P15_3	P15_2	P15_1	P15_0
SR20	—	—	P16_1	P16_0
SR21	P17_3	P17_2	P17_1	P17_0
SR22_L	P18_3	P18_2	P18_1	P18_0
SR22_H	—	—	P18_5	P18_4

41.3.9 Pull Up/Pull down Switching Register (PUPD)

The PUPD register sets pull-up and pull-down of the GPIO pins and the special purpose pins.

For the offset address, refer to **Section 41.2.9, Pull Up/Pull down Switching Register (PUPD)**.

Bit	31	30	29	28	27	26	25	24	23	22	21	20	19	18	17	16
	—	—	—	—	—	—	PUPD3		—	—	—	—	—	—	PUPD2	
Initial Value	—	—	—	—	—	—	0	0	—	—	—	—	—	—	0	0
R/W	R	R	R	R	R	R	R/W	R/W	R	R	R	R	R	R	R/W	R/W
Bit	15	14	13	12	11	10	9	8	7	6	5	4	3	2	1	0
	—	—	—	—	—	—	PUPD1		—	—	—	—	—	—	PUPD0	
Initial Value	—	—	—	—	—	—	0	0	—	—	—	—	—	—	0	0
R/W	R	R	R	R	R	R	R/W	R/W	R	R	R	R	R	R	R/W	R/W

Bit	Bit Name	Initial Value	R/W	Description
31 to 26, 23 to 18, 15 to 10, 7 to 2	—	—	R	Reserved When read, the initial value is read. The written value will be ignored.
25, 24	PUPD3	00b	R/W	These bits set pull-up and pull-down of each pin (PUPD7 to PUPD0) 00b: Neither pull-up nor pull-down is set. 01b : Pull-up is selected. 10b: Pull-down is selected. 11b: Setting prohibited Please refer to the table below for the correspondence of each terminal.
17, 16	PUPD2	00b	R/W	
9, 8	PUPD1	00b	R/W	
1, 0	PUPD0	00b	R/W	

Table 41.9 Correspondence between register and each terminal (1/2)

Bit Name	bit25-24	bit17-16	bit9-8	bit1-0
PUPD06	—	—	P19_1	—
PUPD07_L	P20_3	P20_2	P20_1	P20_0
PUPD07_H	P20_7	P20_6	P20_5	P20_4
PUPD08	—	—	P21_1	—
PUPD09	P22_3	P22_2	P22_1	P22_0
PUPD0A_L	P23_3	P23_2	P23_1	—
PUPD0A_H	—	—	—	P23_4
PUPD0B_L	P24_3	P24_2	P24_1	—
PUPD0B_H	—	—	P24_5	P24_4
PUPD0F_L	P28_3	P28_2	P28_1	P28_0
PUPD0F_H	—	—	P28_5	P28_4
PUPD10	P0_3	P0_2	P0_1	P0_0
PUPD15_L	P5_3	P5_2	P5_1	P5_0
PUPD15_H	—	—	—	P5_4
PUPD16_L	P6_3	P6_2	P6_1	P6_0
PUPD16_H	—	—	—	P6_4
PUPD1B	P11_3	P11_2	P11_1	P11_0
PUPD1C	—	—	P12_1	P12_0

Table 41.9 Correspondence between register and each terminal (2/2)

Bit Name	bit25-24	bit17-16	bit9-8	bit1-0
PUPD1D_L	P13_3	P13_2	P13_1	P13_0
PUPD1D_H	—	—	—	P13_4
PUPD1E	—	P14_2	P14_1	P14_0
PUPD1F	P15_3	P15_2	P15_1	P15_0
PUPD20	—	—	P16_1	P16_0
PUPD21	P17_3	P17_2	P17_1	P17_0
PUPD22_L	P18_3	P18_2	P18_1	P18_0
PUPD22_H	—	—	P18_5	P18_4

41.3.10 Write protected register (PWPR)

The PWPR register sets write permission / prohibition for the PFC register and the PFCWE bit of this register.

For the offset address, refer to **Section 41.2.10, Write protected register (PWPR)**.

Bit	31	30	29	28	27	26	25	24	23	22	21	20	19	18	17	16
	—	—	—	—	—	—	—	—	—	—	—	—	—	—	—	—
Initial Value	—	—	—	—	—	—	—	—	—	—	—	—	—	—	—	—
R/W	R	R	R	R	R	R	R	R	R	R	R	R	R	R	R	R
Bit	15	14	13	12	11	10	9	8	7	6	5	4	3	2	1	0
	—	—	—	—	—	—	—	—	BOWI	PFCWE	—	—	—	—	—	—
Initial Value	—	—	—	—	—	—	—	—	1	0	0	0	0	0	0	0
R/W	R	R	R	R	R	R	R	R	R/W	R/W	R	R	R	R	R	R

Bit	Bit Name	Initial Value	R/W	Description
31 to 8	—	All 0	R	Reserved When read, the initial value is read. When writing, be sure to write the initial value. Operation is not guaranteed if a value other than the initial value is written.
7	BOWI	1b	R/W	1b: Writing a value to the PFCWE bit disabled 0b: Writing a value to the PFCWE bit enabled
6	PFCWE	0b	R/W	1b: Writing a value to the PFC register enabled 0b: Writing a value to the PFC register disabled
5 to 0	—	All 0	R	Reserved When read, the initial value is read. The written value will be ignored.

41.3.11 Digital Noise Filter Switching Register (FILONOFF)

This register controls whether the digital noise filter is enabled / disabled for GPIO input pin and NMI pin.

For the offset address, refer to **Section 41.2.11, Digital Noise Filter Switching Register (FILONOFF)**.

Bit	31	30	29	28	27	26	25	24	23	22	21	20	19	18	17	16
	—	—	—	—	—	—	—	FILON3	—	—	—	—	—	—	—	FILON2
Initial Value	—	—	—	—	—	—	—	0	—	—	—	—	—	—	—	0
R/W	R	R	R	R	R	R	R	R/W	R	R	R	R	R	R	R	R/W
Bit	15	14	13	12	11	10	9	8	7	6	5	4	3	2	1	0
	—	—	—	—	—	—	—	FILON1	—	—	—	—	—	—	—	FILON0
Initial Value	—	—	—	—	—	—	—	0	—	—	—	—	—	—	—	0
R/W	R	R	R	R	R	R	R	R/W	R	R	R	R	R	R	R	R/W

Bit	Bit Name	Initial Value	R/W	Description
31 to 25, 23 to 17, 15 to 9, 7 to 1	—	—	R	Reserved When read, the initial value is read. The written value will be ignored.
24	FILON3	0b	R/W	These bits set the enable or the disable of Digital noise filter of each pin. (FILON7 to FILON0) 0b: No filter is used. 1b: A filter is used.
16	FILON2	0b	R/W	
8	FILON1	0b	R/W	
0	FILON0	0b	R/W	Please refer to the table below for the correspondence of each terminal.

Note: Before setting this register, disable interrupt detection of the Interrupt controller.

Table 41.10 Correspondence between register and each terminal (1/2)

Bit Name	bit24	bit16	bit8	bit0
FILONOFF01	—	—	—	NMI
FILONOFF06	—	—	P19_1	—
FILONOFF07	—	P20_2	P20_1	P20_0
FILONOFF0B_L	—	—	—	—
FILONOFF0B_H	—	—	P24_5	—
FILONOFF0C	—	—	P25_1	—
FILONOFF0F_L	P28_3	P28_2	P28_1	P28_0
FILONOFF0F_H	—	—	P28_5	P28_4
FILONOFF10	P0_3	P0_2	P0_1	P0_0
FILONOFF11_L	P1_3	P1_2	P1_1	P1_0
FILONOFF11_H	—	—	—	P1_4
FILONOFF12	P2_3	P2_2	P2_1	P2_0
FILONOFF13	P3_3	P3_2	P3_1	P3_0
FILONOFF14_L	P4_3	P4_2	P4_1	P4_0
FILONOFF14_H	—	—	P4_5	P4_4
FILONOFF15_L	P5_3	P5_2	P5_1	P5_0
FILONOFF15_H	—	—	—	P5_4
FILONOFF16_L	P6_3	P6_2	P6_1	P6_0

Table 41.10 Correspondence between register and each terminal (2/2)

Bit Name	bit24	bit16	bit8	bit0
FILONOFF16_H	—	—	—	P6_4
FILONOFF17_L	P7_3	P7_2	P7_1	P7_0
FILONOFF17_H	—	—	—	P7_4
FILONOFF18_L	P8_3	P8_2	P8_1	P8_0
FILONOFF18_H	—	—	—	P8_4
FILONOFF19	P9_3	P9_2	P9_1	P9_0
FILONOFF1A_L	P10_3	P10_2	P10_1	P10_0
FILONOFF1A_H	—	—	—	P10_4
FILONOFF1B	P11_3	P11_2	P11_1	P11_0
FILONOFF1C	—	—	P12_1	P12_0
FILONOFF1D_L	P13_3	P13_2	P13_1	P13_0
FILONOFF1D_H	—	—	—	P13_4
FILONOFF1E	—	P14_2	P14_1	P14_0
FILONOFF1F	P15_3	P15_2	P15_1	P15_0
FILONOFF20	—	—	P16_1	P16_0
FILONOFF21	P17_3	P17_2	P17_1	P17_0
FILONOFF22_L	P18_3	P18_2	P18_1	P18_0
FILONOFF22_H	—	—	P18_5	P18_4

41.3.12 Digital Noise Filter Number Register (FILNUM)

This register sets the number of FF stages of digital noise filter for GPIO pin and NMI pin.

For the offset address, refer to **Section 41.2.12, Digital Noise Filter Number Register (FILNUM)**.

Bit	31	30	29	28	27	26	25	24	23	22	21	20	19	18	17	16
	—	—	—	—	—	—	FILNUM3		—	—	—	—	—	—	FILNUM2	
Initial Value	—	—	—	—	—	—	0	0	—	—	—	—	—	—	0	0
R/W	R	R	R	R	R	R	R/W	R/W	R	R	R	R	R	R	R/W	R/W
Bit	15	14	13	12	11	10	9	8	7	6	5	4	3	2	1	0
	—	—	—	—	—	—	FILNUM1		—	—	—	—	—	—	FILNUM0	
Initial Value	—	—	—	—	—	—	0	0	—	—	—	—	—	—	0	0
R/W	R	R	R	R	R	R	R/W	R/W	R	R	R	R	R	R	R/W	R/W

Bit	Bit Name	Initial Value	R/W	Description
31 to 26, 23 to 18, 15 to 10, 7 to 2	—	—	R	Reserved When read, the initial value is read. The written value will be ignored.
25, 24	FILNUM3	00b	R/W	00b: 4-stage filter (41.666 ns x 4 = 166.666 ns) (initial value)
17, 16	FILNUM2	00b	R/W	01b: 8-stage filter (41.666 ns x 8 = 333.333 ns)
9, 8	FILNUM1	00b	R/W	10b: 12-stage filter (41.666 ns x 12 = 500 ns)
1, 0	FILNUM0	00b	R/W	11b: 16-stage filter (41.666 ns x 16 = 666.666 ns)

Note: This value is the value when the external clock is 24MHz.

Please refer to the table below for the correspondence of each terminal.

Note: Before setting this register, disable interrupt detection of the Interrupt controller.

Table 41.11 Correspondence between register and each terminal (1/2)

Bit Name	bit25-24	bit17-16	bit9-8	bit1-0
FILNUM01	—	—	—	NMI
FILNUM06	—	—	P19_1	—
FILNUM07	—	P20_2	P20_1	P20_0
FILNUM0B_L	—	—	—	—
FILNUM0B_H	—	—	P24_5	—
FILNUM0C	—	—	P25_1	—
FILNUM0F_L	P28_3	P28_2	P28_1	P28_0
FILNUM0F_H	—	—	P28_5	P28_4
FILNUM10	P0_3	P0_2	P0_1	P0_0
FILNUM11_L	P1_3	P1_2	P1_1	P1_0
FILNUM11_H	—	—	—	P1_4
FILNUM12	P2_3	P2_2	P2_1	P2_0
FILNUM13	P3_3	P3_2	P3_1	P3_0
FILNUM14_L	P4_3	P4_2	P4_1	P4_0
FILNUM14_H	—	—	P4_5	P4_4
FILNUM15_L	P5_3	P5_2	P5_1	P5_0

Table 41.11 Correspondence between register and each terminal (2/2)

Bit Name	bit25-24	bit17-16	bit9-8	bit1-0
FILNUM15_H	—	—	—	P5_4
FILNUM16_L	P6_3	P6_2	P6_1	P6_0
FILNUM16_H	—	—	—	P6_4
FILNUM17_L	P7_3	P7_2	P7_1	P7_0
FILNUM17_H	—	—	—	P7_4
FILNUM18_L	P8_3	P8_2	P8_1	P8_0
FILNUM18_H	—	—	—	P8_4
FILNUM19	P9_3	P9_2	P9_1	P9_0
FILNUM1A_L	P10_3	P10_2	P10_1	P10_0
FILNUM1A_H	—	—	—	P10_4
FILNUM1B	P11_3	P11_2	P11_1	P11_0
FILNUM1C	—	—	P12_1	P12_0
FILNUM1D_L	P13_3	P13_2	P13_1	P13_0
FILNUM1D_H	—	—	—	P13_4
FILNUM1E	—	P14_2	P14_1	P14_0
FILNUM1F	P15_3	P15_2	P15_1	P15_0
FILNUM20	—	—	P16_1	P16_0
FILNUM21	P17_3	P17_2	P17_1	P17_0
FILNUM22_L	P18_3	P18_2	P18_1	P18_0
FILNUM22_H	—	—	P18_5	P18_4

41.3.13 Digital Noise Filter Clock Selection Register (FILCLKSEL)

The FILCLKSEL register selects the divided clock to be input to digital noise filters.

For the offset address, refer to **Section 41.2.13, Digital Noise Filter Clock Selection Register (FILCLKSEL)**.

Bit	31	30	29	28	27	26	25	24	23	22	21	20	19	18	17	16
	—	—	—	—	—	—	FILCLK3		—	—	—	—	—	—	FILCLK2	
Initial Value	—	—	—	—	—	—	0	0	—	—	—	—	—	—	0	0
R/W	R	R	R	R	R	R	R/W	R/W	R	R	R	R	R	R	R/W	R/W
Bit	15	14	13	12	11	10	9	8	7	6	5	4	3	2	1	0
	—	—	—	—	—	—	FILCLK1		—	—	—	—	—	—	FILCLK0	
Initial Value	—	—	—	—	—	—	0	0	—	—	—	—	—	—	0	0
R/W	R	R	R	R	R	R	R/W	R/W	R	R	R	R	R	R	R/W	R/W

Bit	Bit Name	Initial Value	R/W	Description
31 to 26, 23 to 18, 15 to 10, 7 to 2	—	—	R	Reserved When read, the initial value is read. The written value will be ignored.
25, 24	FILCLK3	00b	R/W	00b: Not divided (initial value)
17, 16	FILCLK2	00b	R/W	01b: Divided by 9000 (41.666 ns x 9000 = 375,000 ns)
9, 8	FILCLK1	00b	R/W	10b: Divided by 18000 (41.666 ns x 18000 = 750,000 ns)
1, 0	FILCLK0	00b	R/W	11b: Divided by 36000 (41.666 ns x 36000 = 1,500,000 ns)

Note: This value is the value when the external clock is 24MHz.

Please refer to the table below for the correspondence of each terminal.

Note: Before setting this register, disable interrupt detection of the Interrupt controller.

Table 41.12 Correspondence between register and each terminal (1/2)

Bit Name	bit25-24	bit17-16	bit9-8	bit1-0
FILCLKSEL01	—	—	—	NMI
FILCLKSEL06	—	—	P19_1	—
FILCLKSEL07	—	P20_2	P20_1	P20_0
FILCLKSEL0B_L	—	—	—	—
FILCLKSEL0B_H	—	—	P24_5	—
FILCLKSEL0C	—	—	P25_1	—
FILCLKSEL0F_L	P28_3	P28_2	P28_1	P28_0
FILCLKSEL0F_H	—	—	P28_5	P28_4
FILCLKSEL10	P0_3	P0_2	P0_1	P0_0
FILCLKSEL11_L	P1_3	P1_2	P1_1	P1_0
FILCLKSEL11_H	—	—	—	P1_4
FILCLKSEL12	P2_3	P2_2	P2_1	P2_0
FILCLKSEL13	P3_3	P3_2	P3_1	P3_0
FILCLKSEL14_L	P4_3	P4_2	P4_1	P4_0
FILCLKSEL14_H	—	—	P4_5	P4_4
FILCLKSEL15_L	P5_3	P5_2	P5_1	P5_0

Table 41.12 Correspondence between register and each terminal (2/2)

Bit Name	bit25-24	bit17-16	bit9-8	bit1-0
FILCLKSEL15_H	—	—	—	P5_4
FILCLKSEL16_L	P6_3	P6_2	P6_1	P6_0
FILCLKSEL16_H	—	—	—	P6_4
FILCLKSEL17_L	P7_3	P7_2	P7_1	P7_0
FILCLKSEL17_H	—	—	—	P7_4
FILCLKSEL18_L	P8_3	P8_2	P8_1	P8_0
FILCLKSEL18_H	—	—	—	P8_4
FILCLKSEL19	P9_3	P9_2	P9_1	P9_0
FILCLKSEL1A_L	P10_3	P10_2	P10_1	P10_0
FILCLKSEL1A_H	—	—	—	P10_4
FILCLKSEL1B	P11_3	P11_2	P11_1	P11_0
FILCLKSEL1C	—	—	P12_1	P12_0
FILCLKSEL1D_L	P13_3	P13_2	P13_1	P13_0
FILCLKSEL1D_H	—	—	—	P13_4
FILCLKSEL1E	—	P14_2	P14_1	P14_0
FILCLKSEL1F	P15_3	P15_2	P15_1	P15_0
FILCLKSEL20	—	—	P16_1	P16_0
FILCLKSEL21	P17_3	P17_2	P17_1	P17_0
FILCLKSEL22_L	P18_3	P18_2	P18_1	P18_0
FILCLKSEL22_H	—	—	P18_5	P18_4

The operation of the digital noise filter will be explained using a timing chart using the external terminal P0_0 as an example.

(1) When the digital noise filter is disabled (FILONOFF = 0)

The timing chart of FILONOFF = 0 (OFF), FILNUM [1: 0] = "00" (FF4 stage), FILCLKSEL [1: 0] = "00" (without frequency division) is shown below.

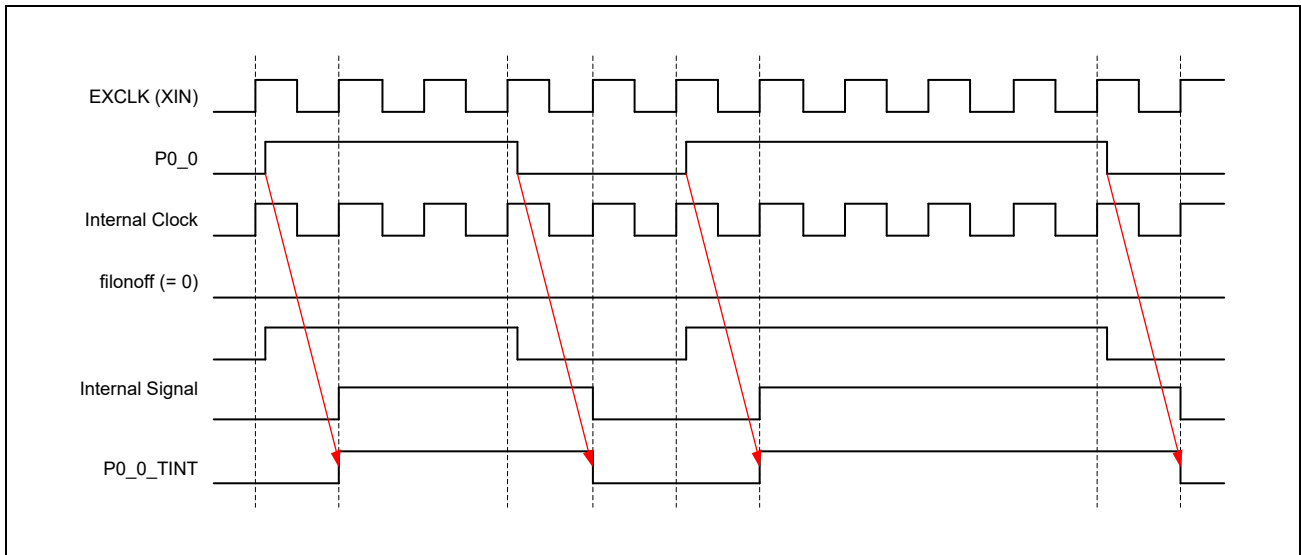

Figure 41.14 Digital noise filter (FILONOFF = 0) timing chart

The signal at the external terminal (P0_0) is not filtered regardless of the number of stages set in the FILNUM register.

The digital noise filter circuit inserts one stage of FF in the output of a digital noise filter.

Therefore, the external terminal (P0_0) signal is propagated internally with a delay of one cycle. (EXCLK (XIN)).

(2) When the digital noise filter is enabled (FILONOFF = 1)

The timing chart of FILONOFF = 1 (ON), FILNUM [1: 0] = “00” (FF4 stage), FILCLKSEL [1: 0] = “00” (without frequency division) is shown below.

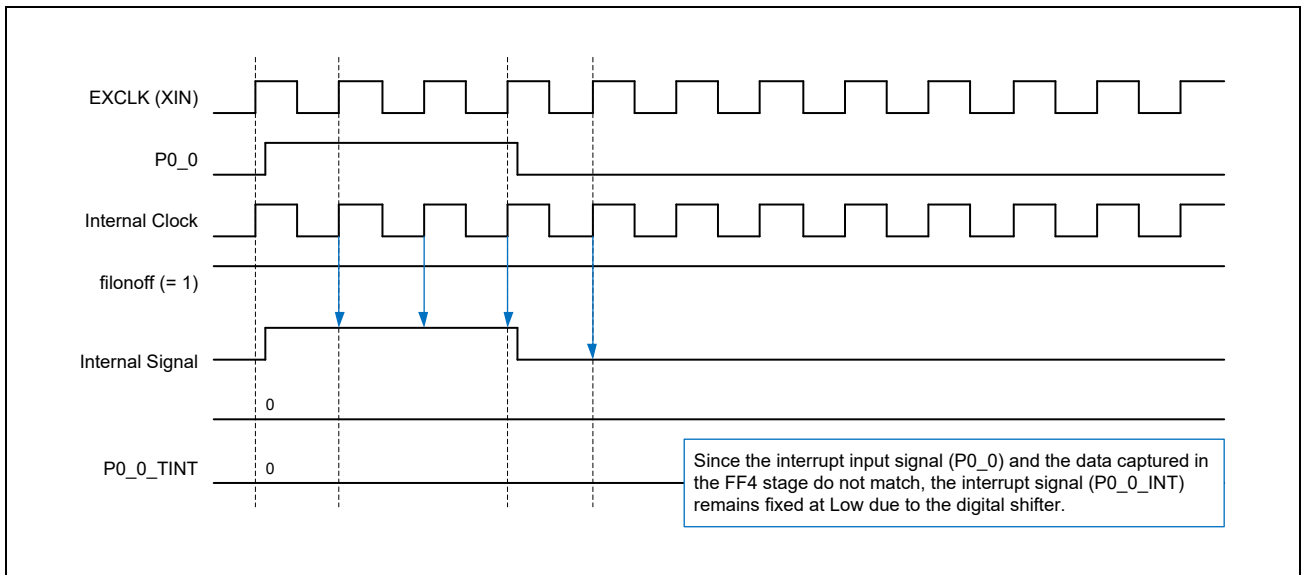

Figure 41.15 Digital noise filter (FILONOFF = 1) Timing chart (1)

The signal of the external terminal (P0_0) is filtered, if even one signal captured by each FF for the number of FF stages set in the FILNUM register does not match.

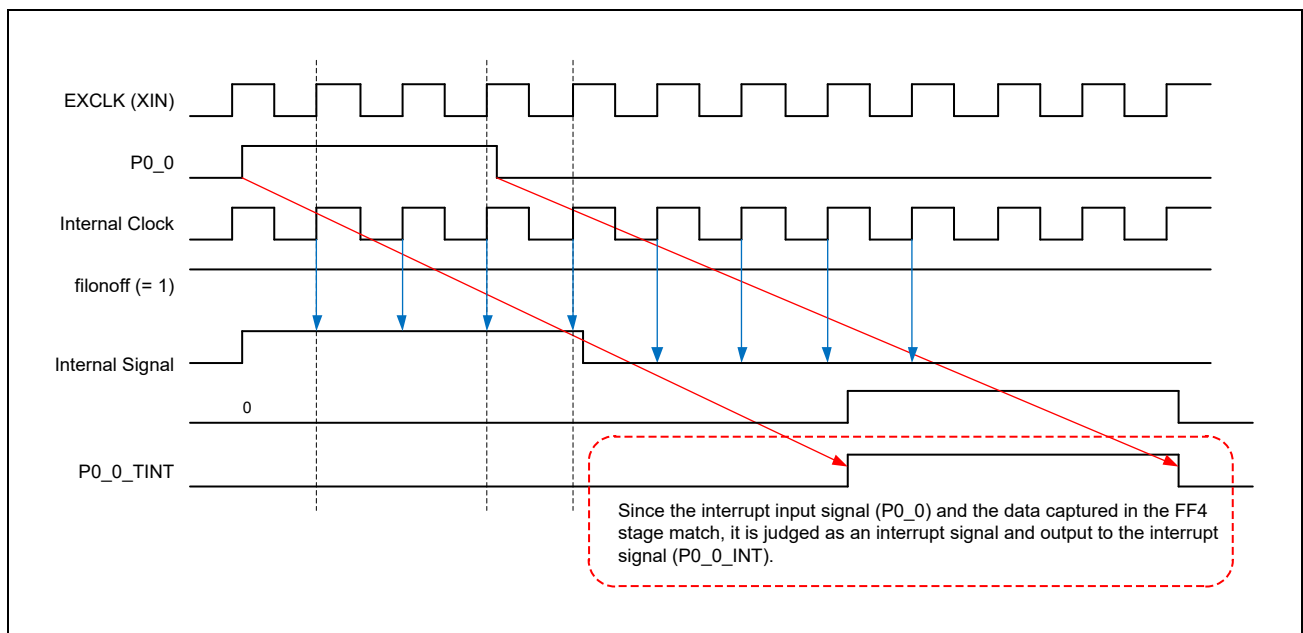

Figure 41.16 Digital noise filter (FILONOFF = 1) Timing chart (2)

The external terminal (P0_0) signal is the signal captured by each FF for the number of FF stages set in the FILNUM register. If they all match, no filtering is done.

The digital noise filter circuit outputs to the interrupt signal with a delay of FILTER_CYCLE.

[FILTER_CYCLE Calculation]

$$\text{FILTER_CYCLE} = \text{FILNUM_FF} + \$\text{FILTER_FF}$$

FILNUM_FF: Number of FF stages set in the FILNUM register @EXCLK(XIN)

FILTER_FF: FF 2 stage in digital noise filter @EXCLK(XIN) + Digital noise filter output

FF 1 stage @EXCLK(XIN)

Note: One stage of FF is inserted in the final stage of the digital noise filter circuit. Therefore, interrupt signals less than 1CLK @ EXCLK (XIN) may be removed regardless of whether the digital noise filter is enabled or disabled.

41.3.14 Ether ch0 Voltage Mode Control Register (ETH_ch0)

This register is sets the IO voltage mode control of Ether ch0.

For the offset address, refer to **Section 41.2.14, Ether ch0 IO Voltage Mode Control Register (ETH_ch0)**.

Bit	31	30	29	28	27	26	25	24	23	22	21	20	19	18	17	16
	—	—	—	—	—	—	—	—	—	—	—	—	—	—	—	—
Initial Value	—	—	—	—	—	—	—	—	—	—	—	—	—	—	—	—
R/W	R	R	R	R	R	R	R	R	R	R	R	R	R	R	R	R
Bit	15	14	13	12	11	10	9	8	7	6	5	4	3	2	1	0
	—	—	—	—	—	—	—	—	—	—	—	—	—	—	ETH0_2 .5V_PV DD	ETH0_1 .8V_PV DD
Initial Value	—	—	—	—	—	—	—	—	—	—	—	—	—	—	0	0
R/W	R	R	R	R	R	R	R	R	R	R	R	R	R	R	R/W	R/W

Bit	Bit Name	Initial Value	R/W	Description															
31 to 2	—	—	R	Reserved When read, the initial value is read. When writing, be sure to write the initial value. Operation is not guaranteed if a value other than the initial value is written.															
1	ETH0_2.5V_PVDD	0b	R/W	These bits set the IO voltage mode.															
0	ETH0_1.8V_PVDD	0b	R/W	<table border="1"> <thead> <tr> <th>Bit 1</th> <th>Bit 0</th> <th>IO Voltage</th> </tr> </thead> <tbody> <tr> <td>0</td> <td>0</td> <td>3.3V (Initial value)</td> </tr> <tr> <td>0</td> <td>1</td> <td>1.8V</td> </tr> <tr> <td>1</td> <td>0</td> <td>2.5V</td> </tr> <tr> <td>1</td> <td>1</td> <td>Setting prohibited</td> </tr> </tbody> </table>	Bit 1	Bit 0	IO Voltage	0	0	3.3V (Initial value)	0	1	1.8V	1	0	2.5V	1	1	Setting prohibited
Bit 1	Bit 0	IO Voltage																	
0	0	3.3V (Initial value)																	
0	1	1.8V																	
1	0	2.5V																	
1	1	Setting prohibited																	

- For the IO voltage mode of P1_0 to P4_5, set the above register according to the voltage mode of the external device to be connected.
- At Function1, the Ether ch0 function is selected, so set the value of this register according to the power supply voltage (ETHER0_PVDD) to be used.

When Function2 to Function7, a function other than Ether ch0 is selected, so set the value of this register to IO voltage mode (3.3v).

For each peripheral function, refer to Function0 to Function7 in the Pin function List.

For Function2 to Function7, only 3.3V can be set.

Note: When setting this register, do not set the IO voltage mode lower than the applied voltage. For example, if the applied voltage is set to 3.3V and the register is set to 1.8V, the reliability of this LSI will be affected.

41.3.15 Ether ch1 Voltage Mode Control Register (ETH_ch1)

This register sets the IO voltage mode control for Etherch1.

For the offset address, refer to **Section 41.2.15, Ether ch1 IO Voltage Mode Control Register (ETH_ch1)**.

Bit	31	30	29	28	27	26	25	24	23	22	21	20	19	18	17	16
	—	—	—	—	—	—	—	—	—	—	—	—	—	—	—	—
Initial Value	—	—	—	—	—	—	—	—	—	—	—	—	—	—	—	—
R/W	R	R	R	R	R	R	R	R	R	R	R	R	R	R	R	R
Bit	15	14	13	12	11	10	9	8	7	6	5	4	3	2	1	0
	—	—	—	—	—	—	—	—	—	—	—	—	—	—	ETH1_2 .5V_PV DD	ETH1_1 .8V_PV DD
Initial Value	—	—	—	—	—	—	—	—	—	—	—	—	—	—	0	0
R/W	R	R	R	R	R	R	R	R	R	R	R	R	R	R	R/W	R/W

Bit	Bit Name	Initial Value	R/W	Description															
31 to 2	—	—	R	Reserved When read, the initial value is read. When writing, be sure to write the initial value. Operation is not guaranteed if a value other than the initial value is written.															
1	ETH1_2.5V_PVDD	0b	R/W	These bits set the IO voltage mode.															
				<table border="1"> <thead> <tr> <th>Bit 1</th> <th>Bit 0</th> <th>IO Voltage</th> </tr> </thead> <tbody> <tr> <td>0</td> <td>0</td> <td>3.3V (Initial value)</td> </tr> <tr> <td>0</td> <td>1</td> <td>1.8V</td> </tr> <tr> <td>1</td> <td>0</td> <td>2.5V</td> </tr> <tr> <td>1</td> <td>1</td> <td>Setting prohibited</td> </tr> </tbody> </table>	Bit 1	Bit 0	IO Voltage	0	0	3.3V (Initial value)	0	1	1.8V	1	0	2.5V	1	1	Setting prohibited
Bit 1	Bit 0	IO Voltage																	
0	0	3.3V (Initial value)																	
0	1	1.8V																	
1	0	2.5V																	
1	1	Setting prohibited																	
0	ETH1_1.8V_PVDD	0b	R/W																

- For the IO voltage mode of P7_0 to P10_4, set the above register according to the voltage mode of the external device to be connected.
- At Function1, the Ether ch1 function is selected, so set the value of this register according to the power supply voltage (ETHER1_PVDD) to be used.

When Function2 to Function7, a function other than Ether ch1 is selected, so set the value of this register to IO voltage mode (3.3v).

For each peripheral function, refer to Function0 to Function7 in the Pin function List.

For Function2 to Function7, only 3.3V can be set.

Note: When setting this register, do not set the IO voltage mode lower than the applied voltage. For example, if the applied voltage is set to 3.3V and the register is set to 1.8V, the reliability of this LSI will be affected.

41.3.16 Ether MII/RGMII Mode Control Register (ETH MII/RGMII)

This register can be selected “MII” or “RGMII” of Ether.

This register is valid only for Function1

For the offset address, refer to **Section 41.2.16, Ether MII/RGMII Mode Control Register (ETH MII/RGMII)**.

Bit	31	30	29	28	27	26	25	24	23	22	21	20	19	18	17	16
	—	—	—	—	—	—	—	—	—	—	—	—	—	—	—	—
Initial Value	—	—	—	—	—	—	—	—	—	—	—	—	—	—	—	—
R/W	R	R	R	R	R	R	R	R	R	R	R	R	R	R	R	R
Bit	15	14	13	12	11	10	9	8	7	6	5	4	3	2	1	0
	—	—	—	—	—	—	—	—	—	—	—	—	—	—	ETH1_mode	ETH0_mode
Initial Value	—	—	—	—	—	—	—	—	—	—	—	—	—	—	1	1
R/W	R	R	R	R	R	R	R	R	R	R	R	R	R	R	R/W	R/W

Bit	Bit Name	Initial Value	R/W	Description
31 to 2	—	—	R	Reserved When read, the initial value is read. When writing, be sure to write the initial value. Operation is not guaranteed if a value other than the initial value is written.
1	ETH1_mode	1b	R/W	Ether MII or RGMII can be selected by setting this register. 0b = RGMII The Direction of the ET1_TXC/TX_CLK is Output. 1b = MII (Initial value) The Direction of the ET1_TXC/TX_CLK is Input.
0	ETH0_mode	1b	R/W	Ether MII or RGMII can be selected by setting this register. 0b = RGMII The Direction of the ET0_TXC/TX_CLK is Output. 1b = MII (Initial value) The Direction of the ET0_TXC/TX_CLK is Input.

Note: By setting this register, the direction of some pins when using Ether’s MII or RGMII can be selected.
Refer to **Section 30, Gigabit Ethernet Interface** chapter for switching between MII and RGMII of Ether.

Note: In RGMII mode, set the external terminals shown below to port mode (PMCn = 0) and I/O disabled (PMn = 00b).

Ether ch0		Ether ch1	
Terminal name Function0	Terminal name Function1	Terminal name Function0	Terminal name Function1
P2_2	ET0_TX_COL	P8_2	ET1_TX_COL
P2_3	ET0_TX_CRS	P8_3	ET1_TX_CRS
P4_2	ET0_RX_ERR	P10_1	ET1_RX_ERR

41.3.17 SD ch0 IO Voltage Mode Control Register (SD_ch0)

This register sets the IO voltage mode control of SD ch0.

For the offset address, refer to **Section 41.2.17, SD ch0 IO Voltage Mode Control Register (SD_ch0)**.

Bit	31	30	29	28	27	26	25	24	23	22	21	20	19	18	17	16
	—	—	—	—	—	—	—	—	—	—	—	—	—	—	—	—
Initial Value	—	—	—	—	—	—	—	—	—	—	—	—	—	—	—	—
R/W	R	R	R	R	R	R	R	R	R	R	R	R	R	R	R	R
Bit	15	14	13	12	11	10	9	8	7	6	5	4	3	2	1	0
	—	—	—	—	—	—	—	—	—	—	—	—	—	—	—	SD0_PVDD
Initial Value	—	—	—	—	—	—	—	—	—	—	—	—	—	—	—	0*1
R/W	R	R	R	R	R	R	R	R	R	R	R	R	R	R	R	R/W*1

Note 1. In Boot Mode1 and Boot Mode2, R/W is R (Read Only).

Bit	Bit Name	Initial Value	R/W	Description
31 to 1	—	—	R	Reserved When read, the initial value is read. When writing, be sure to write the initial value. Operation is not guaranteed if a value other than the initial value is written.
0	SD0_PVDD	0b*1	R/W	This bit sets the IO voltage mode. 1b: I/O domain voltage ≤ 1.8V 0b: I/O domain voltage ≥ 3.3V (Initial value)*1

Note 1. The initial value of this register

- The IO voltage mode of SD0_CLK, SD0_CMD, SD0_DATA [7-0], SD0_RST# is set by selecting each mode of this register and MD_BOOT [2: 0].
 - When Boot Modes 1 and 2 are not selected: This register can be Read/Write (R/W). The initial value is the above value.
 - When Boot Modes 1 and 2 are selected: This register is Read Only (R), and the voltage mode of the selected device is as follows.

MD_BOOT[2:0]			Mode	Selection function	Selection Device	Control method
0	0	1	Boot Mode 1	SDHI0	eMMC(1.8V)	By Hardware
0	1	0	Boot Mode 2	SDHI0	eMMC(3.3V)	By Hardware
Other			SD_ch0 Control by Register			

Note: When setting this register, do not set the IO voltage mode lower than the applied voltage. For example, if the applied voltage is set to 3.3V and the register is set to 1.8V, the reliability of this LSI will be affected.

41.3.18 SD ch1 IO Voltage Mode Control Register (SD_ch1)

This register sets the IO voltage mode control of SD ch1.

For the offset address, refer to **Section 41.2.18, SD ch1 IO Voltage Mode Control Register (SD_ch1)**.

Bit	31	30	29	28	27	26	25	24	23	22	21	20	19	18	17	16
	—	—	—	—	—	—	—	—	—	—	—	—	—	—	—	—
Initial Value	—	—	—	—	—	—	—	—	—	—	—	—	—	—	—	—
R/W	R	R	R	R	R	R	R	R	R	R	R	R	R	R	R	R
Bit	15	14	13	12	11	10	9	8	7	6	5	4	3	2	1	0
	—	—	—	—	—	—	—	—	—	—	—	—	—	—	—	SD1_PVDD
Initial Value	—	—	—	—	—	—	—	—	—	—	—	—	—	—	—	0
R/W	R	R	R	R	R	R	R	R	R	R	R	R	R	R	R	R/W

Bit	Bit Name	Initial Value	R/W	Description
31 to 1	—	—	R	Reserved When read, the initial value is read. When writing, be sure to write the initial value. Operation is not guaranteed if a value other than the initial value is written.
0	SD1_PVDD	0b	R/W	This bit sets the IO voltage mode. 1b: I/O domain voltage \leq 1.8V 0b: I/O domain voltage \geq 3.3V (Initial value)

Note: The IO voltage mode of SD1_CLK, SD1_CMD, SD1_DATA [3-0] is set by this register.

Note: When setting this register, do not set the IO voltage mode lower than the applied voltage. For example, if the applied voltage is set to 3.3V and the register is set to 1.8V, the reliability of this LSI will be affected.

41.3.19 QSPI IO Voltage Mode Control Register (QSPI)

This register sets the IO voltage mode control of QSPI.

For the offset address, refer to **Section 41.2.19, QSPI IO Voltage Mode Control Register (QSPI)**.

Bit	31	30	29	28	27	26	25	24	23	22	21	20	19	18	17	16
	—	—	—	—	—	—	—	—	—	—	—	—	—	—	—	—
Initial Value	—	—	—	—	—	—	—	—	—	—	—	—	—	—	—	—
R/W	R	R	R	R	R	R	R	R	R	R	R	R	R	R	R	R
Bit	15	14	13	12	11	10	9	8	7	6	5	4	3	2	1	0
	—	—	—	—	—	—	—	—	—	—	—	—	—	—	—	QSPI_PVDD
Initial Value	—	—	—	—	—	—	—	—	—	—	—	—	—	—	—	0
R/W	R	R	R	R	R	R	R	R	R	R	R	R	R	R	R	R/W

Note 1. In Boot Mode3 and Boot Mode4, R/W is R (Read Only).

Bit	Bit Name	Initial Value	R/W	Description
31 to 1	—	—	R	Reserved When read, the initial value is read. When writing, be sure to write the initial value. Operation is not guaranteed if a value other than the initial value is written.
0	QSPI_PVDD	0b*1	R/W	This bit sets the IO voltage mode. 1b: I/O domain voltage ≤ 1.8V 0b: I/O domain voltage ≥ 3.3V (Initial value)*1

Note 1. The initial value of this register

- The IO voltage of QSPI0_SPCLK, QSPI0_IO[3-0], QSPI0_SSL, QSPI0_RESET#, QSPI0_WP#, QSPI0_INT# is set by each mode of this register and MD_BOOT[2: 0].
 - When Boot Modes 3 and 4 are not selected: This register can be Read/Write (R/W). The initial value is the above value.
 - When Boot Modes 3 and 4 are selected: This register is Read Only (R), and the voltage mode of the selected device is as follows.

MD_BOOT[2:0]		Mode	Selection Function	Selection Device	Control method
0	1	1	SPI Multi I/O Bus Controller	Single/Quad(1.8V)	By Hardware
1	0	0		Single/Quad(3.3V)	By Hardware
Other		QSPI Control by register			

Note: When setting this register, do not set the IO voltage mode lower than the applied voltage. For example, if the applied voltage is set to 1.8V and the register is set to 3.3V, the reliability of this LSI will be affected.

41.3.20 Input Enable Control Register (IEN)

This register is a register that controls the input of the special purpose port.

For the offset address, refer to **Section 41.2.20, Input Enable Control Register (IEN)**.

Bit	31	30	29	28	27	26	25	24	23	22	21	20	19	18	17	16
	—	—	—	—	—	—	—	IEN3	—	—	—	—	—	—	—	IEN2
Initial Value	—	—	—	—	—	—	—	0	—	—	—	—	—	—	—	0
R/W	R	R	R	R	R	R	R	R/W	R	R	R	R	R	R	R	R/W
Bit	15	14	13	12	11	10	9	8	7	6	5	4	3	2	1	0
	—	—	—	—	—	—	—	IEN1	—	—	—	—	—	—	—	IEN0
Initial Value	—	—	—	—	—	—	—	0	—	—	—	—	—	—	—	0
R/W	R	R	R	R	R	R	R	R/W	R	R	R	R	R	R	R	R/W

Bit	Bit Name	Initial Value	R/W	Description
31 to 25, 23 to 17, 15 to 9, 7 to 1	—	—	R	Reserved When read, the initial value is read. The written value will be ignored.
24	IEN3	0b	R/W	These bits control inputs of p bit of a pin with a multiplexed function (except for GPIO) and a dedicated pin (p = 0 to 7) 0b: Input disabled (Initial value) 1b: Input enabled
16	IEN2	0b	R/W	
8	IEN1	0b	R/W	
0	IEN0	0b	R/W	Please refer to the table below for the correspondence of each terminal.

Table 41.13 Correspondence between register and each terminal

Bit Name	bit24	bit16	bit8	bit0
IEN02	—	—	—	TMS/SWDIO
IEN04	—	—	AUDIO_CLK2	AUDIO_CLK1
IEN06	—	—	P19_1	—
IEN07_L	P20_3	P20_2	P20_1	P20_0
IEN07_H	P20_7	P20_6	P20_5	P20_4
IEN08	—	—	P21_1	—
IEN09	P22_3	P22_2	P22_1	P22_0
IEN0E	RIIC1_SCL	RIIC1_SDA	RIIC0_SCL	RIIC0_SDA

41.4 Operation

The operating procedure for the general-purpose I/O port function and the operating procedure for peripheral functions are shown below.

41.4.1 Operation for GPIO Function

- (1) Set the PMCn register to “0” (initial value = 0).
 - (2) Set the GPIO input / output with the PMn register.
 - (3) Set the GPIO output value in the Pn register.
 - (4) The input value of the input terminal can be detected by the PINn register.
 - (5) When setting the interrupt input using the GPIO input pin, set the ISEL register to “1”.
- Set the FILONOFF, IOLH, SR, and PUPD registers between (1) and (2) as necessary.
 - Set the FILONOFF register when using GPIO to set a digital noise filter for interrupt input and GPIO input.
 - Set the FILNUM and FILCLKSEL registers according to the purpose of use.

41.4.2 Operation for Peripheral Function

- (1) Set the PMCn register to “1” (initial value = 0).
 - (2) Set the PWPR register to allow writing to the PFCm register.
After setting the PWPR.B0WI bit to “0” (initial value = 1), set the PWPR.PFCWE bit to “1” (initial value = 0).
Select the required function from Functions 1-7. (Hereafter, Function1 setting example)
 - (3) Set PFCm = 001b and switch to Function1.
 - (4) Set the PFCm register to write-protected. After setting the PWPR.PFCWE bit to “0”, set the PWPR.B0WI bit to “1”.
- Set the FILONOFF, IOLH, SR, and PUPD registers between (1) and (2) as necessary.
 - Set the FILONOFF register when using GPIO to set a digital noise filter for the IRQ[0-7].
 - Set the FILNUM and FILCLKSEL registers according to the purpose of use. And also, the NMI input can set the noise filter by the same registers.

42. Low Power Mode

This chapter describes the lower mode of this LSI.

42.1 Overview

This LSI has two modes of low power consumption shown in the following table.

These two modes work independently.

Table 42.1 Low Power Mode

Low Power Mode	Description	Return factor
Module Standby Mode	Stop the clock of specific peripheral module by setting the CPG register. Refer to Section 42.2, Module Standby Mode for detail.	CPG register setting
AX45MP Sleep Mode	Put AX45MP into a low power state by issuing a WFI instruction. Refer to Section 2.4.1, AX45MP Sleep Mode for detail.	Interrupt

Note: When a system reset is applied, the LSI is released from the low power mode and initialized.

42.2 Module Standby Mode

42.2.1 Overview

The Module Standby Mode is a mode that requests the clock stop of the module specified by the master.

The purpose of this mode is to reduce power consumption by stopping unnecessary functions.

The master which can request the clock stop is AX45MP. So, AX45MP cannot be placed in the Module Standby Mode. To reduce the power consumption in the CPUs, use the CPU sleep modes to be described later.

This mode is implemented by stopping the clock supply by the CPG register and switching the MSTOP signal of the bus through CPG register settings.

If the master accesses a module that has the clock stopped and the MSTOP bit set, a bus error will occur.

The following registers are used in the Module Standby Mode.

Table 42.2 Module Standby Mode related registers

Register name	Abbreviation	Description
Clock Control Register	CPG_CLKON_***	The detail information of each register is described in Section 6, System Controller (SYSC) and Section 7, Clock Pulse Generator (CPG) . The usage of these registers is described in Section 42.2.2, Operation .
MSTOP Register	CPG_BUS_***_MSTOP	

The following figure shows the block connection overview related Module Standby Mode.

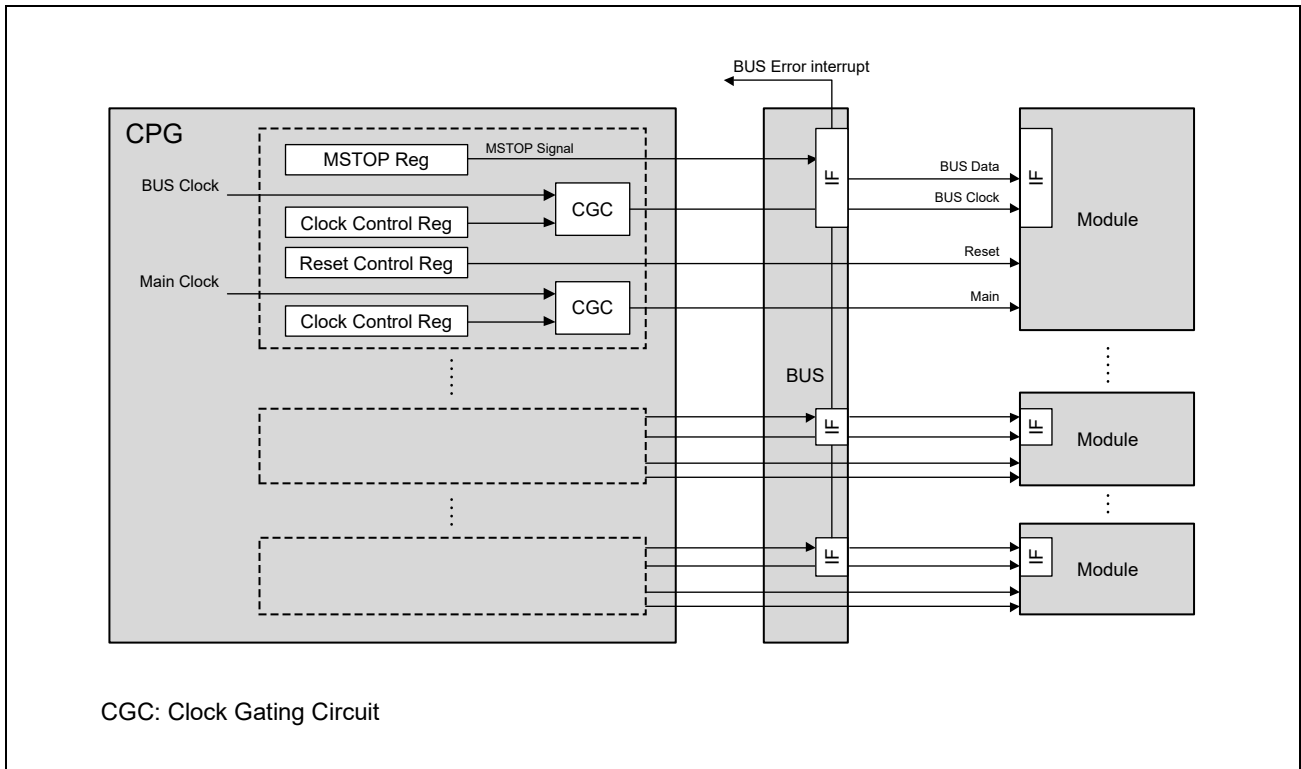

Figure 42.1 Block connection overview for Module Standby Mode

42.2.2 Operation

The following chart shows the procedure to enter and return from the Module Standby Mode.

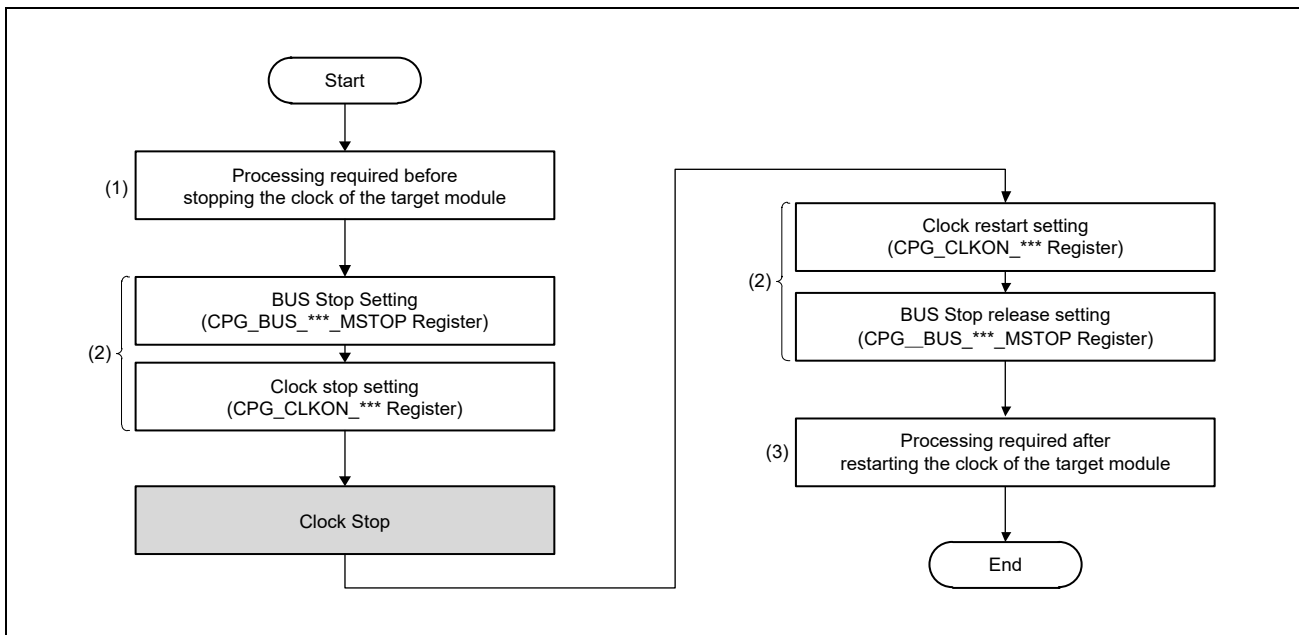

Figure 42.2 Module Standby Mode procedure

- (1) Depend on the module, there may be a request to stop during communication, image processing, and various processing. In this case, if the managed CPU can be stopped unilaterally for each module, a stop request is immediately issued to the CPG. For those that cannot be stopped until a certain process is completed, after confirming that the managed CPU has stopped for each module, a stop request is made to the CPG.
- (2) Refer to **Section 42.2.2.1, Setting of Clock control and MSTOP register** regarding to the setting of Clock Control Register and MSTOP Register.
- (3) Whether the reset control is required depends on the module; check the specifications of the target module. Set the reset control register to 0 to enter the reset state. Set 1 for the release from the reset state.

42.2.2.1 Setting of Clock control and MSTOP register

The following table shows the combination of the Clock Control register and the MSTOP register to stop the clock of the target module.

The Module Standby Mode can be applied only to the modules shown in the table below.

- When entering the Module Standby Mode:
 - Set the MSTOP Register bit of the target module to 1.
 - Set the Clock Control Register bit of the target module to 0.
- When exiting the Module Standby Mode:
 - Set the Clock Control Register bit of the target module to 1.
 - Set the MSTOP Register bit of the target module to 0.

Table 42.3 Registers for Module Standby Mode (1/2)

Target module for Module Standby Mode	Clock Control Register		MSTOP Register	
	Register Name (CPG_CLKON_***)	bit	Register Name (CPG_BUS_***_MSTOP)	bit
PLIC	NCEPLIC	[0]	REG1	[7]
IAX45	IAX45	[1:0]	PERI_CPU	[13]
Debug Module	NCEPLDM	[1]	PERI_CPU	[2]
Machine Timer	NCEPLMT	[0]	PERI_CPU	[3]
DMAC	DMAC_REG	[1:0]	REG1	[3:0]
GTM ch0	GTM	[0]	REG0	[4]
GTM ch1		[1]		[5]
GTM ch2		[2]		[6]
MTU	MTU	[0]	MCPU1	[2]
POE3	POE3	[0]	MCPU1	[9]
WDT ch0	WDT	[1:0]	REG0	[2]
SPI Multi	SPI_MULT1	[1:0]	MCPU1	[1]
SDHI ch0	SDHI	[3:0]	PERI_COM	[0]
SDHI ch1		[7:4]		[1]
SSI ch0	SSI	[1:0]	MCPU1	[10]
SSI ch1		[3:2]		[11]
SSI ch2		[5:4]		[12]
SSI ch3		[7:6]		[13]
USB2.0 ch0	USB	[0], [2]	PERI_COM	[6:5]
USB2.0 ch1		[1]		[7]
USB2.0 PHY*1		[3]		[4]
ETHER ch0	ETH	[0]	PERI_COM	[2]
ETHER ch1		[1]		[3]
I2C ch0	I2C	[0]	MCPU2	[10]
I2C ch1		[1]		[11]
I2C ch2		[2]		[12]
I2C ch3		[3]		[13]

Table 42.3 Registers for Module Standby Mode (2/2)

Target module for Module Standby Mode	Clock Control Register		MSTOP Register	
	Register Name (CPG_CLKON_***)	bit	Register Name (CPG_BUS_***_MSTOP)	bit
SCIF ch0	SCIF	[0]	MCPU2	[1]
SCIF ch1		[1]		[2]
SCIF ch2		[2]		[3]
SCIF ch3		[3]		[4]
SCIF ch4		[4]		[5]
SCI ch0	SCI	[0]	MCPU2	[7]
SCI ch1		[1]		[8]
IRDA	IRDA	[0]	MCPU2	[6]
RSPI ch0	RSPI	[0]	MCPU1	[14]
RSPI ch1		[1]		[15]
RSPI ch2		[2]	MCPU2	[0]
CANFD	CANFD	[0]	MCPU2	[9]
ADC	ADC	[1:0]	MCPU2	[14]
TSU	TSU	[0]	MCPU2	[15]

Note 1. The clock for USB2.0 PHY can only be stopped when the clock for USB2.0 ch0 and ch1 are stopped.

43. Debug Interface

43.1 Overview

This LSI has a debug interface for boundary scan function and debug support for AX45MP.

43.1.1 Features

The functions of the debug interface of this LSI are shown below.

- Debug Specification
 - RISC-V External Debug Support (TD003) V0.13

- Debug Component

This LSI has a following AndesCore™ AX45MP debug subsystem.

 - Debug Transport Module (NCEJDTM200)
 - Debug Module (NCEPLDM200)

- Debug Interface
 - Support JTAG

- Debugger control function
 - Debugger connection permission control
 - Direct control of IP without going through CPU by System Bus Access
 - Support WDT counter stop control function

- Boundary Scan
 - Connection test between this LSI and other LSIs on the user board

For details on NCEPLDM200 and NCEJDTM200, refer to “AndesCore™ AX45MP-1C Processor Reference Manual”.

43.1.2 External Pins

- JTAG pins

The debug interface supports JTAG IF. **Table 43.1** shows the JTAG pins and their functions.

Table 43.1 JTAG Pins

Pin Name	I/O	Function	
		JTAG IF	Name
TCK	Input	TCK	Test clock
TMS	Input	TMS	Test mode select
TDI	Input	TDI	Test data input
TDO	Output	TDO	Test data output
TRST#	Input	TRST	Test reset

- DEBUGEN pins

Table 43.2 shows the functions of the DEBUGEN pin.

Table 43.2 DEBUGEN Pins

Pin Name	I/O	Function
DEBUGEN	Input	Switches between normal operation and debug operation. 0: Normal operation 1: Debug operation

The DEBUGEN value must be fixed before releasing the power-on reset (PRST#). **Table 43.3** shows the difference in operation between normal operation and debug operation.

Table 43.3 Difference in Operation by DEBUGEN

	Normal Operation (DEBUGEN=0)	Debug Operation (DEBUGEN=1)	Related Module
Debug function module (Debug Module)	Boot impossible (Reset state)	Boot (Refer Section 43.6.1 for reset condition and range)	CPG (Reset control)

- BSCANP pins

Table 43.4 shows the functions of the BSCANP pin.

Table 43.4 BSCANP Pins

Pin Name	I/O	Function
BSCANP	Input	Switches between normal operation and boundary scan test mode. 0: Normal operation 1: Boundary scan test mode

Boundary scan test mode is a mode in which a connection test is performed between the terminals of this LSI and other ICs connected on the customer's board and is performed when BSCANP = 1.

The actual access is controlled by the 5 terminals of JTAG when BSCANP = 1.

Table 43.5 shows the operation modes of this LSI according to the values of the DEBUGEN pin and BSCANP pin.

Table 43.5 Operating Mode

Pin Name		Operating Mode
BSCANP	DEBUGEN	
0	0	Normal operation
0	1	Debug operation
1	*	Boundary scan test mode

43.1.3 Treatment of Unused Pins

When the external terminal of the debug interface is not used, handle it as shown in **Table 43.6**.

Table 43.6 Handling of Unused Pins

Pin Name	Handle* ¹
TCK	Fix the level on the pins (pull them up or down, or connect them to the power supply or ground level)
TMS	Fix the level on the pins (pull them up or down, or connect them to the power supply or ground level)
TDI	Fix the level on the pins (pull them up or down, or connect them to the power supply or ground level)
TDO	Open-circuit
TRST#* ²	Fix this pin at a low level (pull down or connect to the ground level)
DEBUGEN	Fix this pin at a low level (pull down or connect to the ground level)
BSCANP	Fix this pin at a low level (pull down or connect to the ground level)

Note 1. Mount the pull-up/pull-down resistors on the board side

Note 2. TRST# should be fixed at low level in non-debug mode, and TRST# should be changed from low level to high level in debug mode.

43.2 Address Space

43.2.1 Debug Module (Access from System Bus)

Debug Module base address: H'0_10C0_0000 (Overall Address Space)

Table 43.7 Address Space of the Debug Module (Access from System Bus)

Address Offset	Component* ¹
H'0000 ~ H'007F	Debug ROM
H'0080 ~ H'00BF	Program Buffer
H'00C0 ~ H'00CF	Abstract Data 0
H'00D0 ~ H'01FF	Reserved for internal use

Note 1. For details on each component, refer to "AndesCore™ AX45MP-1C Processor Reference Manual".

43.2.2 Debug Module (Access from DTM)

Table 43.8 Address Space of the Debug Module (Access from DTM)

Address [8:2]	Component* ¹
H'04 ~ H'07	Abstract Data 0-3
H'10	Debug Module Control
H'11	Debug Module Status
H'12	Hart Info
H'13	Hart Summary
H'14	Hart Array Window Select
H'15	Hart Array Window
H'16	Abstract Control and Status
H'17	Abstract Command
H'18	Abstract Command Autoexec
H'19 ~ H'1C	Device Tree Addr 0-3
H'20 ~ H'2F	Program Buffer 0-15
H'38	System Bus Access Control and Status
H'39 ~ H'3B	System Bus Address
H'3C ~ H'3F	System Bus Data

Note 1. For details on each component, refer to "AndesCore™ AX45MP-1C Processor Reference Manual".

43.2.3 System Bus Access (Access from DM)

Table 43.9 Address Space of the Debug System

Address	Component* ¹
H'00_0000_0000 ~ H'03_FFFF_FFFF	System Bus* ¹

Note 1. For details on System Bus, see **Section 5.2.1, Overall Address Space**.

43.3 Register Descriptions

43.3.1 ID Register (BSID)

The BSID register is a 32-bit register that cannot be accessed from the CPU. When the BSCANP pin is 1, it can be read from the TDO pin by setting the IDCODE command on the TAP controller. It cannot be written.

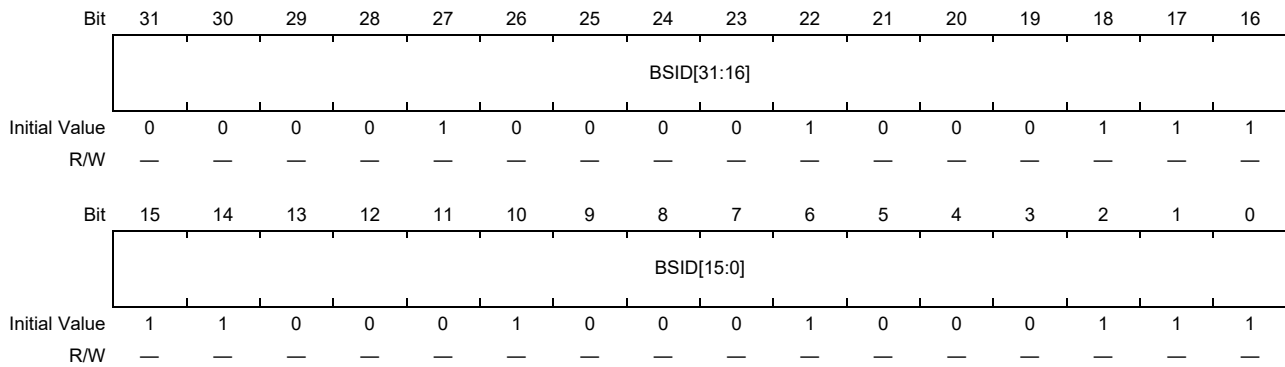

Bit	Bit Name	Initial Value	R/W	Description
31 to 0	BSID[31:0]	H'0847_C 447	—	This is the ID register specified in JTAG. The upper 4 bits (bit31-28) may change depending on the chip version.

43.3.2 Debug Module Registers

For details on Debug Module (NCEPLDM200) registers, refer to “AndesCore™ AX45MP-1C Processor Reference Manual”.

43.4 Debug Connection

43.4.1 Debug Connection Mode

There are the following four modes for the debug connection method of this LSI.

Authentication Mode	Method
No authentication	Allow access from the debugger without authentication (initial setting)
SEC authentication* ¹	Allow access from the debugger after authentication is OK. (authentication method is security authentication by security IP)
Authentication refusal* ¹	Block access from the debugger

Note 1. SEC authentication and Authentication refusal can only be authenticated with secure products.

For SEC authentication modes, enter the authentication code from the debugger is needed.

For information on the authentication function of secure products, please contact our sales.

43.5 Debug Access Range

The debug access range by Debug Module is for all slaves as well as AX45MP. For details, refer to **Section 5.3, Accessible Areas**.

43.6 Operation

43.6.1 Debug Related Reset

Please refer to **Section 7.3.2.1, Range of Reset Application** for debug-related reset and reset range.

43.6.2 WDT Counter Stop Control

This LSI has a WDT counter stop control function linked with a debug event to prevent an unintended reset by WDT during debug operation. When a debug event occurs, Debug Module asserts the WDT counter stop request signal, controls the WDT counter stop signal (CNTSTOP), and stops counting. The target WDT is all WDT. For details on the WDT count stop function, refer to **Section 6.4.2, WDT Stop Control Function**.

43.6.3 GTM Counter Stop Control

This LSI has a GTM counter stop control function linked with debug events to prevent unintended GTM counts during debug operation. When a debug event occurs, Debug Module asserts a GTM counter stop request signal to stop the GTM count.

44. Thermal Sensor Unit (TSU)

This LSI chip incorporates a thermal sensor unit (TSU) that measures the temperature inside the LSI.

44.1 Overview

44.1.1 Features

- This LSI has a single TSU.
- The thermal sensor in this unit measures temperatures in the range from -40°C to 125°C with an accuracy of $\pm 3^{\circ}\text{C}$.
- The TSU repeats measurement at 20- μs intervals, and automatically updates the results of measurement.

44.1.2 Block Diagram

Figure 44.1 is a block diagram of the TSU.

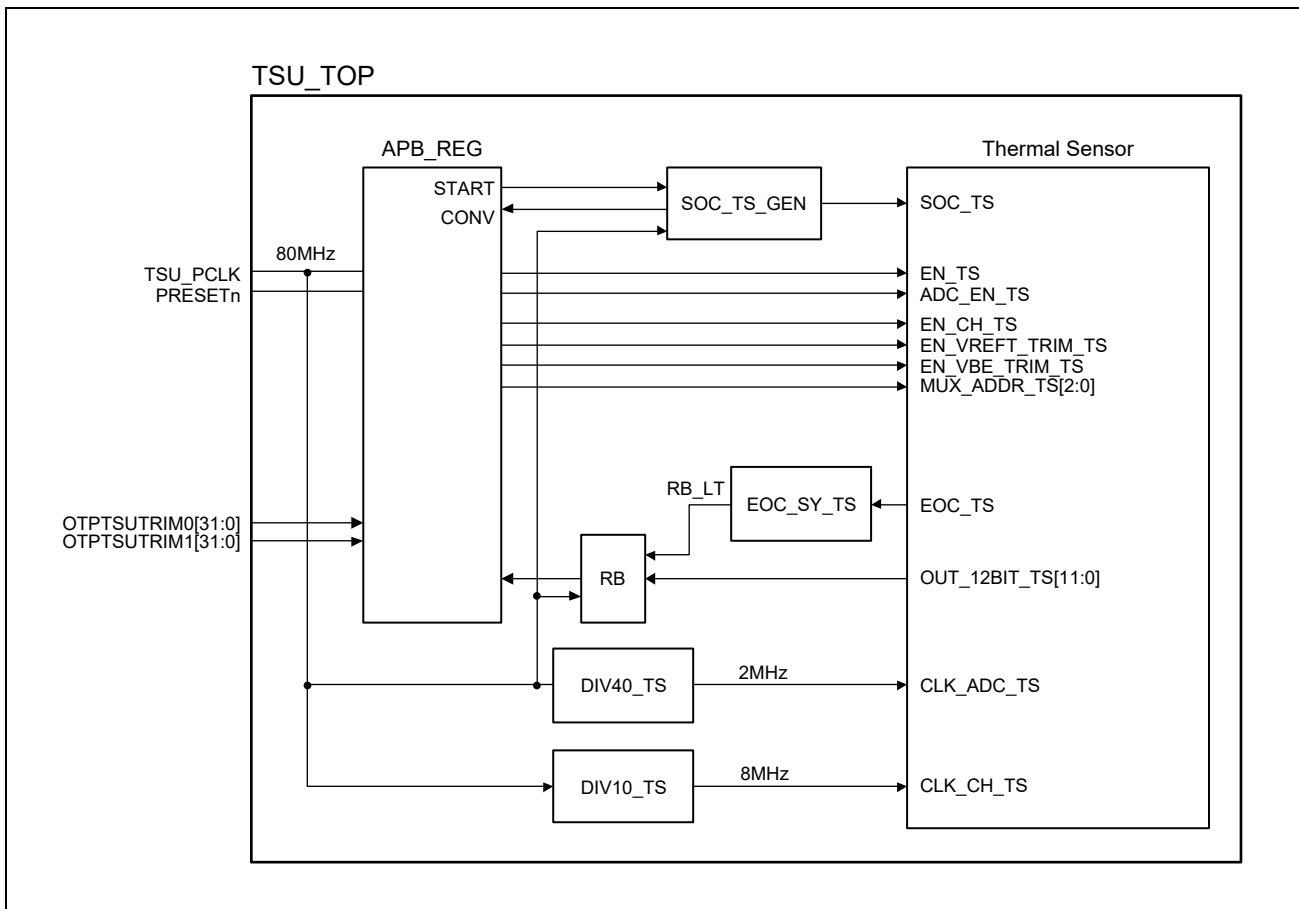

Figure 44.1 Block Diagram of the TSU

The TSU consists of the following blocks.

- APB_REG
- Thermal Sensor
- DIV40_TS and DIV10_TS
- SOC_TS_GEN
- EOC_SY_TS
- Read Buffer (RB)

44.1.2.1 APB_REG

- The APB_REG block provides an external interface for the TSU.
- This block contains control and status registers for the thermal sensor.

44.1.2.2 Thermal Sensor

- The thermal sensor block includes the internal probe, A/D converter and other items.
- The thermal sensor generates 12-bit digital values corresponding to the temperature and outputs them through the OUT_12BIT_TS[11:0] port.

44.1.2.3 DIV40_TS and DIV10_TS

- The TSU operates with the TSU_PCLK clock (80 MHz).
- The DIV40_TS block is a divide-by-40 divider which divides TSU_PCLK to generate a 2-MHz clock frequency to be supplied to the A/D converter in the thermal sensor as CLK_ADC_TS.
- The DIV10_TS block is a divide-by-10 divider which divides TSU_PCLK to generate an 8-MHz clock frequency to be supplied to the thermal sensor core as CLK_CH_TS.

44.1.2.4 SOC_TS_GEN

- The SOC_TS_GEN block generates the SOC_TS signal to be supplied to the thermal sensor for control over the timing of its operations.
- The SOC_TS_GEN block generates the SOC_TS signal every 20 μ s. This is triggered by the START signal from the APB_REG block.
- The SOC_TS_GEN block generates the CONV signal that indicates the operating state of the thermal sensor. The value of the CONV signal can be read through the APB_REG block.

44.1.2.5 EOC_SY_TS

- The EOC_SY_TS block detects the EOC_TS signal from the thermal sensor and generates the RB_LT signal in synchronization with TSU_PCLK.
- The EOC_TS signal indicates the end of A/D conversion of the voltage for the temperature measured by the thermal sensor.

44.1.2.6 Read Buffer (RB)

- The RB block captures the 12-bit digital value from the OUT_12BIT_TS[11:0] port terminals of the thermal sensor in a register. This is triggered by the RB_LT signal from the EOC_SY_TS block. This value corresponds to the measured temperature.
- The value captured in the RB block can be read from the TSU through the APB_REG block.

44.1.3 External Pins

The TSU has no external pins.

44.1.4 Interrupts

The TSU has no interrupts.

44.2 Register Configuration

This section describes the registers for use in controlling the TSU.

Base Address: H'0_1005_9400 (AX45MP Address Space)

44.2.1 List of Register

Table 46 1 lists the TSU registers. All registers are accessible in 32-bit units.

Table 44.1 List of the TSU Registers

Register Name	Abbreviation	R/W	Initial Value	Offset Address	Access Size
Sensor Mode Register	TSU_SM	R/W	H'0000_0000	H'00	32
Sensor Trigger Register	TSU_ST	R/W	H'0000_0000	H'04	32
Sensor ADC Data Register	TSU_SAD	R	H'0000_0000	H'0C	32
Sensor Status Register	TSU_SS	R	H'0000_0000	H'10	32
TSU OTP Calibration Register 0	OTPTSUTRIM0_REG	R	—	H'18	32
TSU OTP Calibration Register 1	OTPTSUTRIM1_REG	R	—	H'1C	32

44.3 Register Descriptions

44.3.1 Sensor Mode Register (TSU_SM)

This register is used to specify the operating mode of the thermal sensor.

Bit	31	30	29	28	27	26	25	24	23	22	21	20	19	18	17	16
	—	—	—	—	—	—	—	—	—	—	—	—	—	—	—	—
Initial Value	0	0	0	0	0	0	0	0	0	0	0	0	0	0	0	0
R/W	R	R	R	R	R	R	R	R	R	R	R	R	R	R	R	R
Bit	15	14	13	12	11	10	9	8	7	6	5	4	3	2	1	0
	—	—	—	—	—	—	—	—	—	—	—	—	—	—	ADC_EN_TS	ADC_EN_TS
Initial Value	0	0	0	0	0	0	0	0	0	0	0	0	0	0	0	0
R/W	R	R	R	R	R	R	R	R	R	R	R	R	R	R	R/W	R/W

Bit	Bit Name	Initial Value	R/W	Description
31 to 2	—	All 0	R	Reserved Whenever it is read, 0 is read. The written value will be ignored.
1	ADC_EN_TS	0b	R/W	These bits specify the operating mode of the thermal sensor.
0	EN_TS	0b	R/W	
	ADC_EN_TS	EN_TS		Operating mode of the thermal sensor
	0b	0b		Power-saving mode
	0b	1b		ADC power-saving mode
	1b	0b		Power-saving mode
	1b	1b		Normal operating mode

44.3.2 Sensor Trigger Register (TSU_ST)

This register is used to start and stop the cycles of A/D conversion by the thermal sensor. The A/D conversion is repeated at 20- μ s intervals once the conversion is started.

Bit	31	30	29	28	27	26	25	24	23	22	21	20	19	18	17	16
	—	—	—	—	—	—	—	—	—	—	—	—	—	—	—	—
Initial Value	0	0	0	0	0	0	0	0	0	0	0	0	0	0	0	0
R/W	R	R	R	R	R	R	R	R	R	R	R	R	R	R	R	R
Bit	15	14	13	12	11	10	9	8	7	6	5	4	3	2	1	0
	—	—	—	—	—	—	—	—	—	—	—	—	—	—	RSV	START
Initial Value	0	0	0	0	0	0	0	0	0	0	0	0	0	0	0	0
R/W	R	R	R	R	R	R	R	R	R	R	R	R	R	R	R/W	R/W

Bit	Bit Name	Initial Value	R/W	Description
31 to 2	—	All 0	R	Reserved Whenever it is read, 0 is read. The written value will be ignored.
1	RSV	0b	R/W	The software may use this bit as a note. The written value is read.
0	START	0b	R/W	This bit starts and stops the cycles of A/D conversion by the thermal sensor. 0b: Stops the A/D conversion*2 1b: Starts the A/D conversion*1

Note 1. Before setting the START bit to 1b, be sure to set the TSU_SM register. Specifically, set the TSU_SM register, wait for 60 μ s, and then set the START bit to 1b.

Note 2. When the START bit is to be set to 0b, be sure to read the A/D-converted value before making the setting.

44.3.3 Sensor ADC Data Register (TSU_SAD)

This register holds the digital value after A/D conversion of the voltage from the thermal sensor.

Bit	31	30	29	28	27	26	25	24	23	22	21	20	19	18	17	16
	—	—	—	—	—	—	—	—	—	—	—	—	—	—	—	—
Initial Value	0	0	0	0	0	0	0	0	0	0	0	0	0	0	0	0
R/W	R	R	R	R	R	R	R	R	R	R	R	R	R	R	R	R
Bit	15	14	13	12	11	10	9	8	7	6	5	4	3	2	1	0
	—	—	—	—	OUT_12BIT_TS											
Initial Value	0	0	0	0	0	0	0	0	0	0	0	0	0	0	0	0
R/W	R	R	R	R	R	R	R	R	R	R	R	R	R	R	R	R

Bit	Bit Name	Initial Value	R/W	Description
31 to 12	—	All 0	R	Reserved Whenever it is read, 0 is read. The written value will be ignored.
11 to 0	OUT_12BIT_TS	H'000	R	These bits hold the digital value after A/D conversion of the voltage from the thermal sensor. The value is 12-bit unsigned.

44.3.4 Sensor Status Register (TSU_SS)

This register indicates the state of A/D conversion in the thermal sensor.

Bit	31	30	29	28	27	26	25	24	23	22	21	20	19	18	17	16
	—	—	—	—	—	—	—	—	—	—	—	—	—	—	—	—
Initial Value	0	0	0	0	0	0	0	0	0	0	0	0	0	0	0	0
R/W	R	R	R	R	R	R	R	R	R	R	R	R	R	R	R	R
Bit	15	14	13	12	11	10	9	8	7	6	5	4	3	2	1	0
	—	—	—	—	—	—	—	—	—	—	—	—	—	—	—	CONV
Initial Value	0	0	0	0	0	0	0	0	0	0	0	0	0	0	0	0
R/W	R	R	R	R	R	R	R	R	R	R	R	R	R	R	R	R

Bit	Bit Name	Initial Value	R/W	Description
31 to 1	—	All 0	R	Reserved Whenever it is read, 0 is read. The written value will be ignored.
0	CONV	0b	R	These bits indicate the state of A/D conversion in the thermal sensor. 0b: A/D conversion is stopped. 1b: A/D conversion is ongoing.

44.3.5 TSU OTP Calibration Register 0 (OTPTSUTRIM0_REG)

This register holds the correction value for calibration to be used in calculating the temperature

Bit	31	30	29	28	27	26	25	24	23	22	21	20	19	18	17	16
	OTPTSUTRIM0_EN	—	—	—	—	—	—	—	—	—	—	—	—	—	—	—
Initial Value	—	—	—	—	—	—	—	—	—	—	—	—	—	—	—	—
R/W	R	R	R	R	R	R	R	R	R	R	R	R	R	R	R	R
Bit	15	14	13	12	11	10	9	8	7	6	5	4	3	2	1	0
	—	—	—	—	OTPTSUTRIM0											
Initial Value	—	—	—	—	—	—	—	—	—	—	—	—	—	—	—	—
R/W	R	R	R	R	R	R	R	R	R	R	R	R	R	R	R	R

Bit	Bit Name	Initial Value	R/W	Description
31	OTPTSUTRIM0_EN	—	R	This bit indicates whether [11:0] OTPTSUTRIM0 is valid or invalid. 0b: [11:0] OTPTSUTRIM0 is invalid. 1b: [11:0] OTPTSUTRIM0 is valid.
30 to 12	—	—	R	Reserved When read, the value is indefinite value. The written value will be ignored.
11 to 0	OTPTSUTRIM0	—	R	These bits hold the correction value for calibration to be used in calculating the temperature.

44.3.6 TSU OTP Calibration Register 1 (OTPTSUTRIM1_REG)

This register holds the correction value for calibration to be used in calculating the temperature.

Bit	31	30	29	28	27	26	25	24	23	22	21	20	19	18	17	16
	OTPTSUTRIM1_EN	—	—	—	—	—	—	—	—	—	—	—	—	—	—	—
Initial Value	—	—	—	—	—	—	—	—	—	—	—	—	—	—	—	—
R/W	R	R	R	R	R	R	R	R	R	R	R	R	R	R	R	R
Bit	15	14	13	12	11	10	9	8	7	6	5	4	3	2	1	0
	—	—	—	—	OTPTSUTRIM1											
Initial Value	—	—	—	—	—	—	—	—	—	—	—	—	—	—	—	—
R/W	R	R	R	R	R	R	R	R	R	R	R	R	R	R	R	R

Bit	Bit Name	Initial Value	R/W	Description
31	OTPTSUTRIM1_EN	—	R	This bit indicates whether [11:0] OTPTSUTRIM1 is valid or invalid. 0b: [11:0] OTPTSUTRIM1 is invalid. 1b: [11:0] OTPTSUTRIM1 is valid.
30 to 12	—	—	R	Reserved When read, the value is indefinite value. The written value will be ignored.
11 to 0	OTPTSUTRIM1	—	R	These bits hold the correction value for calibration to be used in calculating the temperature.

44.4 Operation

44.4.1 Procedure for Starting the A/D Conversion

This section describes the procedure for starting the A/D conversion. Follow this procedure to acquire the A/D converted values for the measured temperatures.

1. Start supplying the clock to the TSU.
2. Release the TSU from the reset state.
3. Set the EN_TS and ADC_EN_TS bits in the TSU_SM register to 1b to place the thermal sensor in the normal operating mode.
4. Wait for 60 μ s, leaving the value of the START bit as 0b.
5. Set the START bit in the TSU_ST register to 1b. The thermal sensor then starts the cycles of A/D conversion and the CONV bit in the TSU_SS register indicates 1b.
6. Once 20 μ s have passed, the first A/D converted value from the thermal sensor is automatically stored in the TSU_SAD register. The value in that register is then updated every 20 μ s. Reading the TSU_SAD register returns the latest A/D converted value.

CAUTION

Ensure that the setting of START is 1b when reading an A/D converted value from the TSU_SAD register.

44.4.2 Procedure for Stopping the A/D Conversion

This section describes the procedure for stopping the A/D conversion.

1. Set the START bit in the TSU_ST register to 0.
2. Poll the CONV bit in the TSU_SS register until it indicates 0b (A/D conversion has stopped).
3. Once you have confirmed that conversion has stopped, set the EN_TS and ADC_EN_TS bits in the TSU_SM register to 0b to place the thermal sensor in the power-saving mode.

CAUTION

If you intend to restart the A/D conversion after having stopped it, start from step 3 in **Section 44.4.1, Procedure for Starting the A/D Conversion**.

44.4.3 Confirming the State of the A/D Conversion by Monitoring the CONV Bit

The A/D conversion by the TSU can be started and stopped by the START bit in the TSU_ST register. However, the timing of stopping the A/D conversion by the thermal sensor is not synchronous with the START bit being set to 0 (stopping the A/D conversion). Monitor the CONV bit in the TSU_SS register to confirm that the A/D conversion by the thermal sensor has stopped.

44.4.4 Procedure for Measuring the Temperature

To calculate the temperature T_j , read registers TSU_SAD, OTPTSUTRIM0_REG, and OTPTSUTRIM1_REG, and follow the procedure below.

1. Read the value of the TSU_SAD register eight times every at least 20 μ s. The read values are defined as TSCode[0] to TSCode[7].
2. Calculate the average of the values read, TSCodeAVE, by using the following formula.

$$\text{TSCodeAVE} = \frac{(\text{TSCode}[0] + \dots + \text{TSCode}[7])}{8}$$

3. Apply curvature correction and calculate DSENSOR by using the following formula.

$$\text{DSENSOR} = \frac{\text{TSCodeAVE}}{(1 + \text{TSCodeAVE} \times 0.000013)}$$

4. Read the correction values for use in calibration from registers OTPTSUTRIM0_REG and OTPTSUTRIM1_REG and use the following formula to calculate T_j .

$$T_j = (\text{DSENSOR} - \text{OTPTSUTRIM1}) \times \left(\frac{165}{(\text{OTPTSUTRIM0} - \text{OTPTSUTRIM1})} \right) - 40$$

44.5 Usage Note

When the START bit in the TSU_ST register is to be set to 0b, be sure to read the A/D-converted value in the TSU_SAD register before making the setting.

45. Trusted Secure IP

This LSI incorporates a Trusted Secure IP module to provide security functions. The module consists of an access management circuit, encryption engine, and random number generator. In combination with the Trusted Secure IP driver, the Trusted Secure IP can prevent eavesdropping (confidentiality), falsification of information (integrity), and impersonation (authenticity).

Key information to be used in encrypting and decrypting data is only stored within the Trusted Secure IP, and any external access can be shut out to obtain a system with strong security.

45.1 Overview

Table 45.1 summarizes the specifications of the Trusted Secure IP. **Figure 45.1** shows a block diagram of the Trusted Secure IP.

Table 45.1 Specifications of Trusted Secure IP (1/2)

Item	Description
Access control	Access management circuit <ul style="list-style-type: none"> • In case of irregular access to the Trusted Secure IP due to a falsified program or runaway execution of a program, this circuit blocks all subsequent access and stops the output of data from the Trusted Secure IP.
Encryption engine	AES: Compliant with NIST FIPS PUB 197 algorithm <ul style="list-style-type: none"> • Key sizes: 128, 192, or 256 bits • Block sizes: 128 bits • Block cipher mode of operation <ul style="list-style-type: none"> – ECB, CBC, CTR: Compliant with NIST SP 800-38A – CMAC: Compliant with NIST SP 800-38B – CCM: Compliant with NIST SP 800-38C – GCM: Compliant with NIST SP 800-38D – XTS: Compliant with NIST SP 800-38E – GCTR • Number of cycles for execution*1 <ul style="list-style-type: none"> – ECB, CBC, CTR, CMAC, GCTR, XTS: 11 cycles of P1φ for 128-bit keys, 13 cycles of P1φ for 192-bit keys, 15 cycles of P1φ for 256-bit keys – CCM: 22 cycles of P1φ for 128-bit keys, 26 cycles of P1φ for 192-bit keys, 30 cycles of P1φ for 256-bit keys AES-GCM AES-GCM is realized by combining AES-GCTR and GHASH.

Table 45.1 Specifications of Trusted Secure IP (2/2)

Item	Description
Encryption engine	<p>RSA</p> <ul style="list-style-type: none"> • Key sizes: Up to 4096 bits • Block sizes: Up to 4096 bits • Number of cycles for execution*1 <ul style="list-style-type: none"> – Approximately 64,000 cycles (Encryption) / 13,000,000 cycles (Decryption) of P1φ. <p>HASH</p> <ul style="list-style-type: none"> • Support for SHA1, SHA224/SHA256, GHASH • Block sizes: 512 bits • Number of cycles for execution*1 <ul style="list-style-type: none"> – SHA1: 80 cycles of P1φ – SHA224/SHA256: 64 cycles of P1φ – GHASH: 9 cycles of P1φ <p>ECC</p> <ul style="list-style-type: none"> • Compatible with ECDSA and ECDH • Data block length: 256 bits
Encryption engine	<p>Key management</p> <ul style="list-style-type: none"> • Keys are only valid within the Trusted Secure IP. • Only key generation information is output from the Trusted Secure IP. • Keys can be regenerated by the input of key generation information to the Trusted Secure IP. <p>Endian</p> <ul style="list-style-type: none"> • Big or little
Generation of random numbers	<p>32-bit true random number generator</p> <ul style="list-style-type: none"> • The Trusted Secure IP driver can assemble 32-bit true random numbers to generate 128- or 256-bit true random numbers. • The generated 128-bit and 256-bit true random numbers are used as keys in encrypting and decrypting data.
Unique ID	<ul style="list-style-type: none"> • An ID unique to the LSI (unique ID) is accessible from the access management circuit through the dedicated bus. • Combining the unique ID with the key generation information prevents the illicit copying of data to another LSI.
Interrupt sources	10
Low power consumption	Setting of the module stop state is possible.

Note 1. This does not include the overhead for calling functions of the Trusted Secure IP driver.

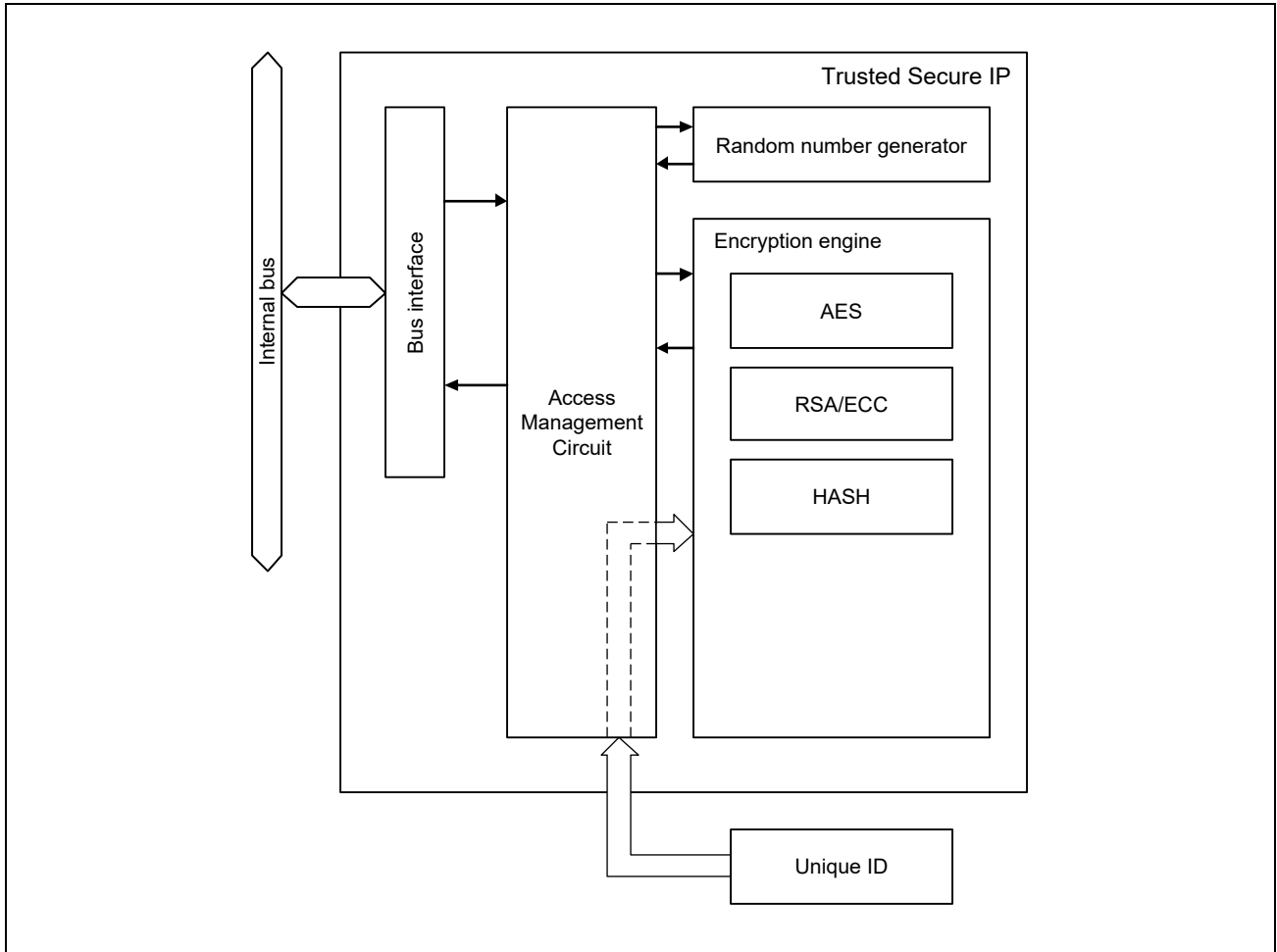

Figure 45.1 Trusted Secure IP Block Diagram

45.2 Operation

45.2.1 Operating Modes and State Transitions

Figure 45.2 shows the state transitions of the Trusted Secure IP.

Use of the Trusted Secure IP security functions is only possible through use of the Trusted Secure IP driver provided by Renesas Electronics, in accordance with the state transitions as shown in the figure below.

When irregular access to the Trusted Secure IP (access that violates the defined procedure) due to a falsified program or a program entering runaway execution, etc. is attempted, the access management circuit does not accept any subsequent access and stops the output of any data from the Trusted Secure IP.

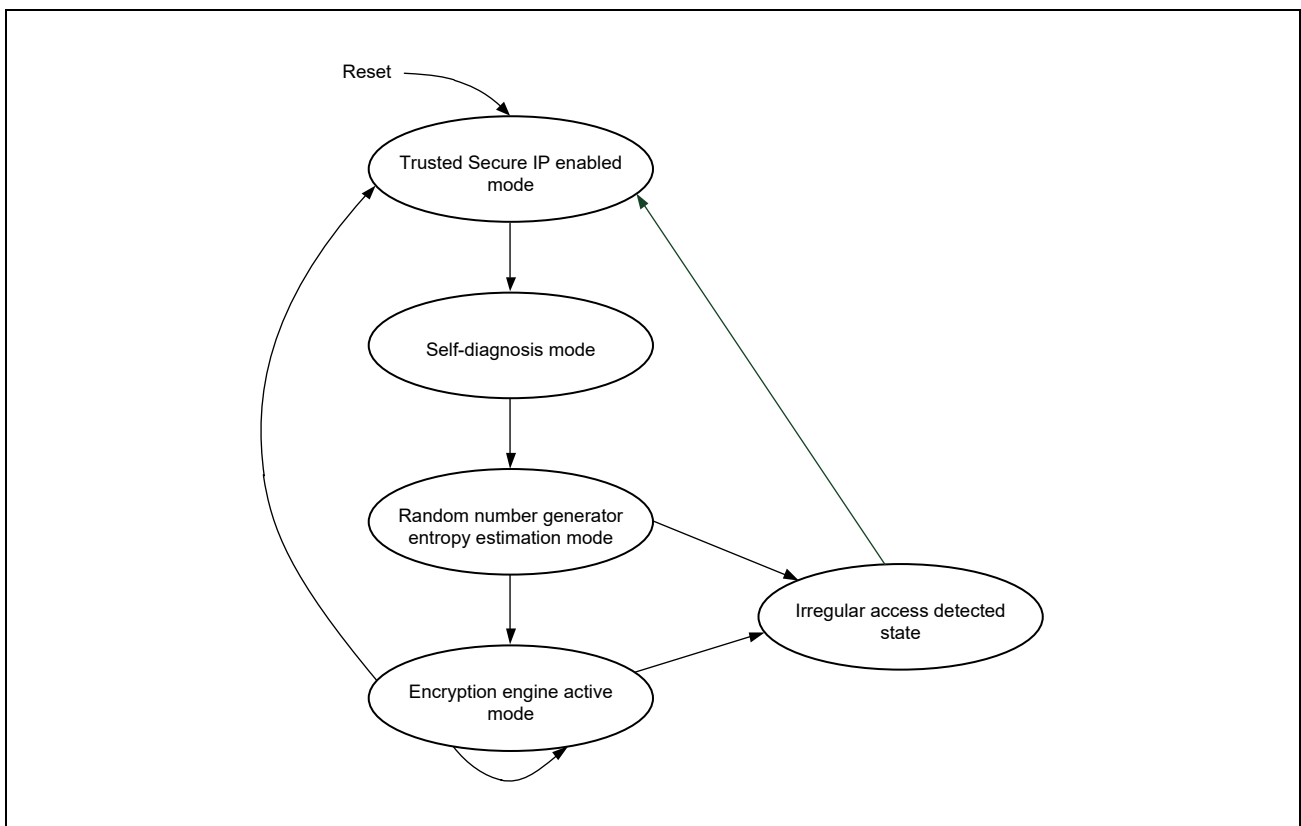

Figure 45.2 Trusted Secure IP Operating Modes and State Transitions

Many of the security functions that the Trusted Secure IP offers are applicable only in the encryption engine active mode. The operations that can be performed in this mode are given below.

- (1) Key Installation
- (2) Encryption and decryption
- (3) Key generation
- (4) Random number generation

45.2.2 Encryption Engine

Figure 45.3 shows processes of the encryption engine integrated in the Trusted Secure IP.

The encryption engine, using the key generation information, performs plaintext to ciphertext encryption and ciphertext to plaintext decryption by hardware.

In no part of the encryption or decryption process, is key data or intermediate data ever exposed outside of the Trusted Secure IP.

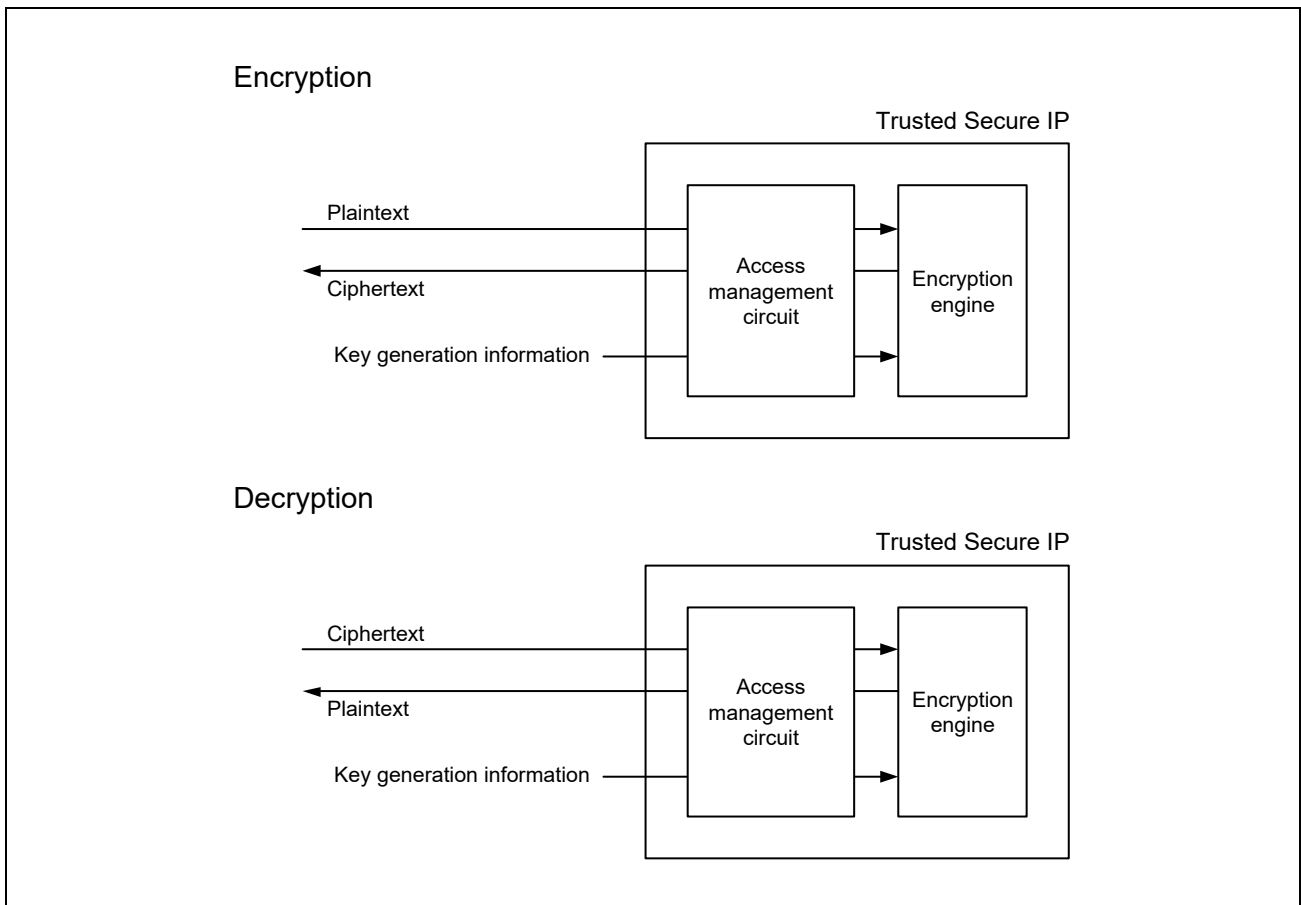

Figure 45.3 Encryption and Decryption processes by Encryption Engine

45.2.3 Key Installation

The key installation is the operation that safely converts the user key to the key generation information and stores it in flash memory. The procedure for installing the key data is given below.

- (1) The user uses the key (Key-2) used for encrypting the user key to encrypt the user key (Key-1) producing eKey-1.
- (2) The user sends the encrypted user key (eKey-1) to the Trusted Secure IP.
- (3) The key generation information of the Key-2 (Index-2) contained in the Trusted Secure IP driver is used to recover the Key-2, which is then used to decrypt the user key.
- (4) The user key is converted to user key generation information (Index-1) using the unique ID and a random number, and stored in flash memory.

The installation process and flow chart are given in **Figure 45.4** and **Figure 45.5**, respectively.

Once the key data is installed, the user key generation information (Index-1) can then be used to perform encryption or decryption.

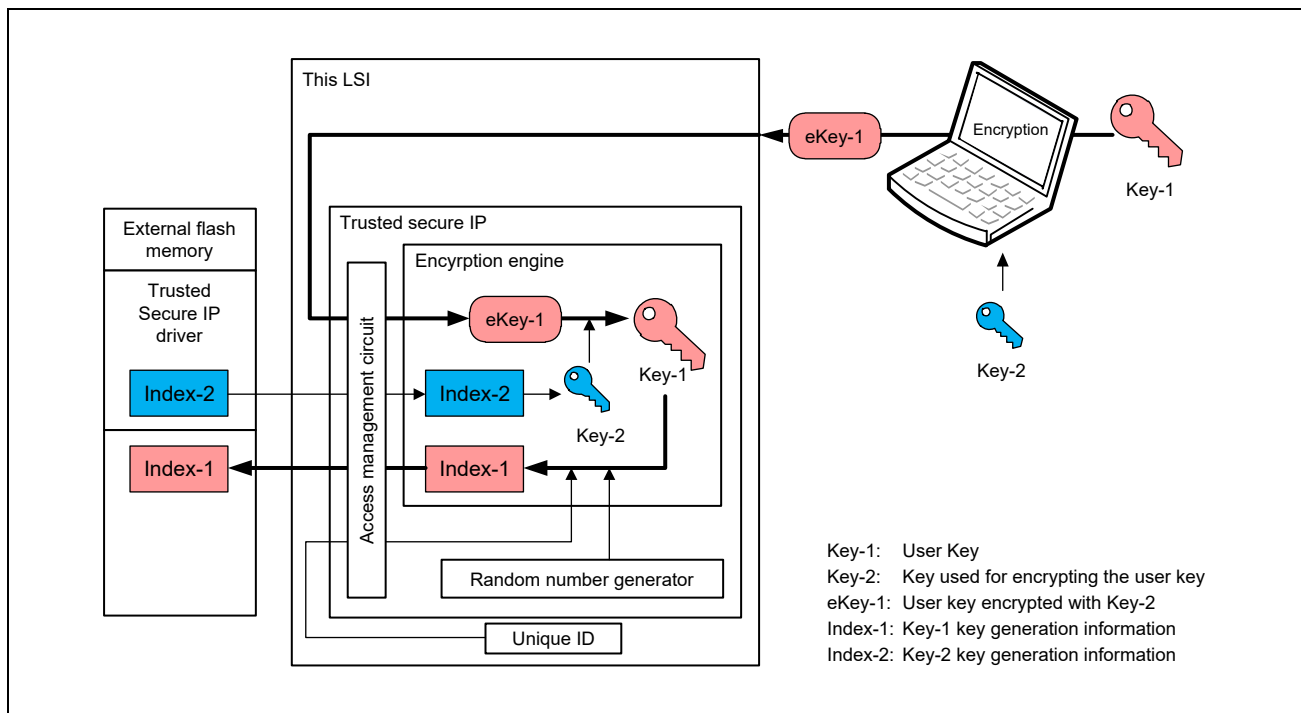

Figure 45.4 Key Installation Process

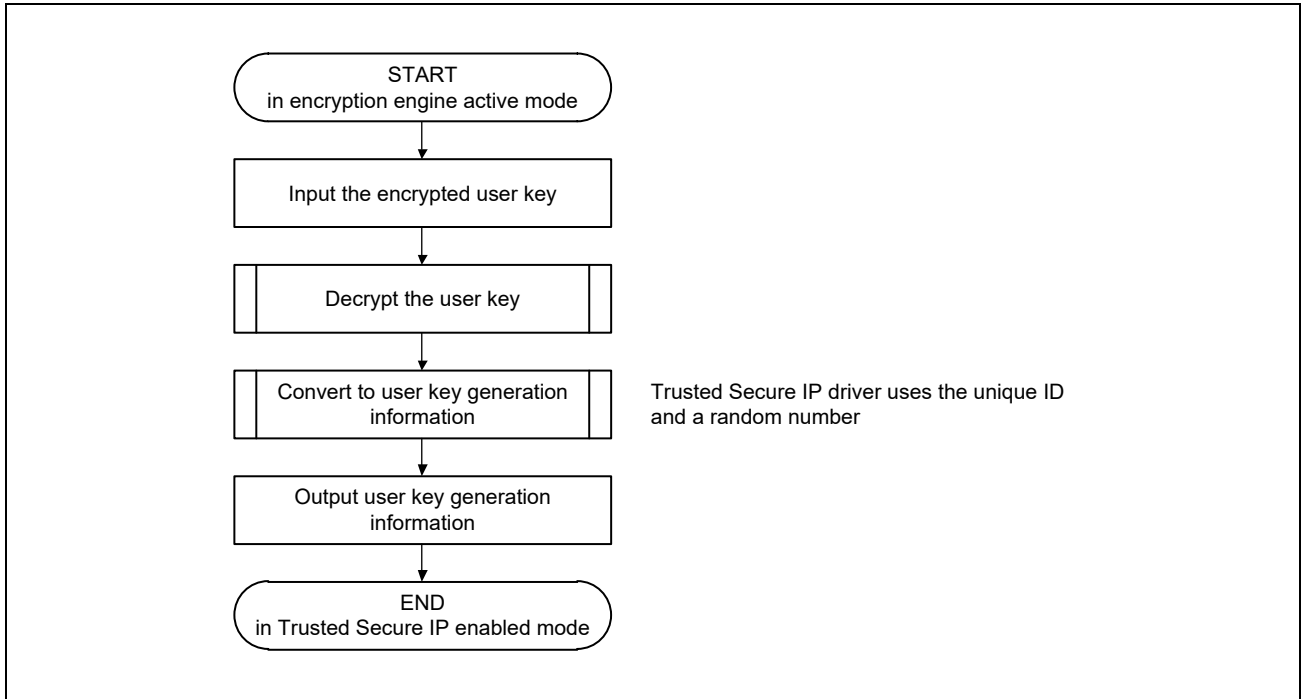

Figure 45.5 Key Installation Flow Chart

45.2.4 Encryption and Decryption

The procedures for encrypting and decrypting data are given below.

- (1) Input the key generation information into the Trusted Secure IP, and recover the key data.
- (2) Input the data to encrypt or decrypt into the Trusted Secure IP. This converts plaintext into ciphertext, and ciphertext into plaintext.
- (3) Read the converted data.

The encryption engine has an input buffer and an output buffer, enabling encryption/decryption to proceed in parallel with data input/output.

Figure 45.6, Figure 45.7, and Figure 45.8 show the timing diagram, encryption flow, and decryption flow, respectively.

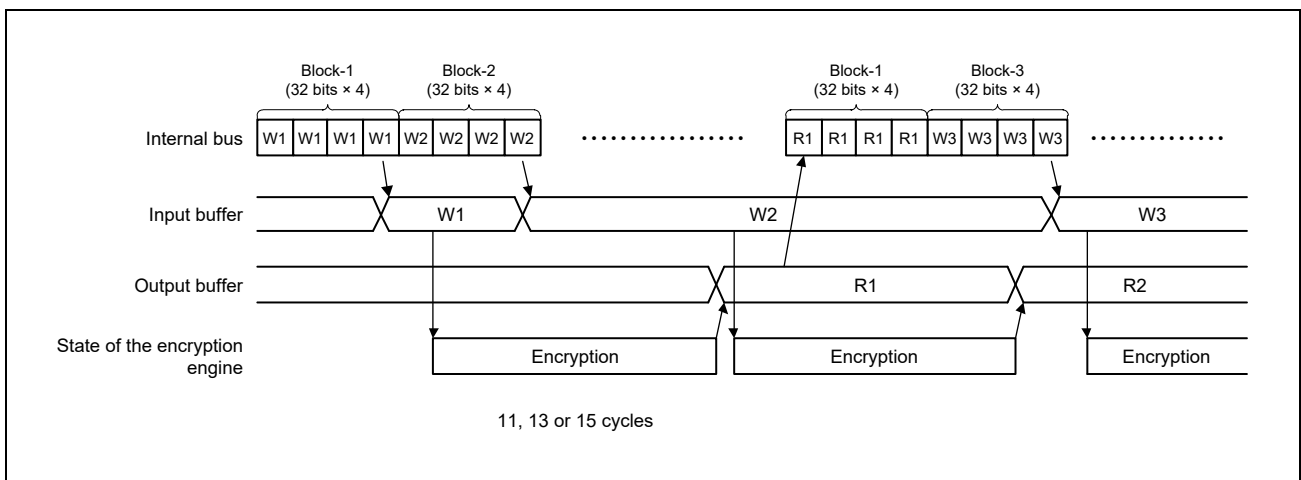

Figure 45.6 Encryption and Decryption Timing Diagram

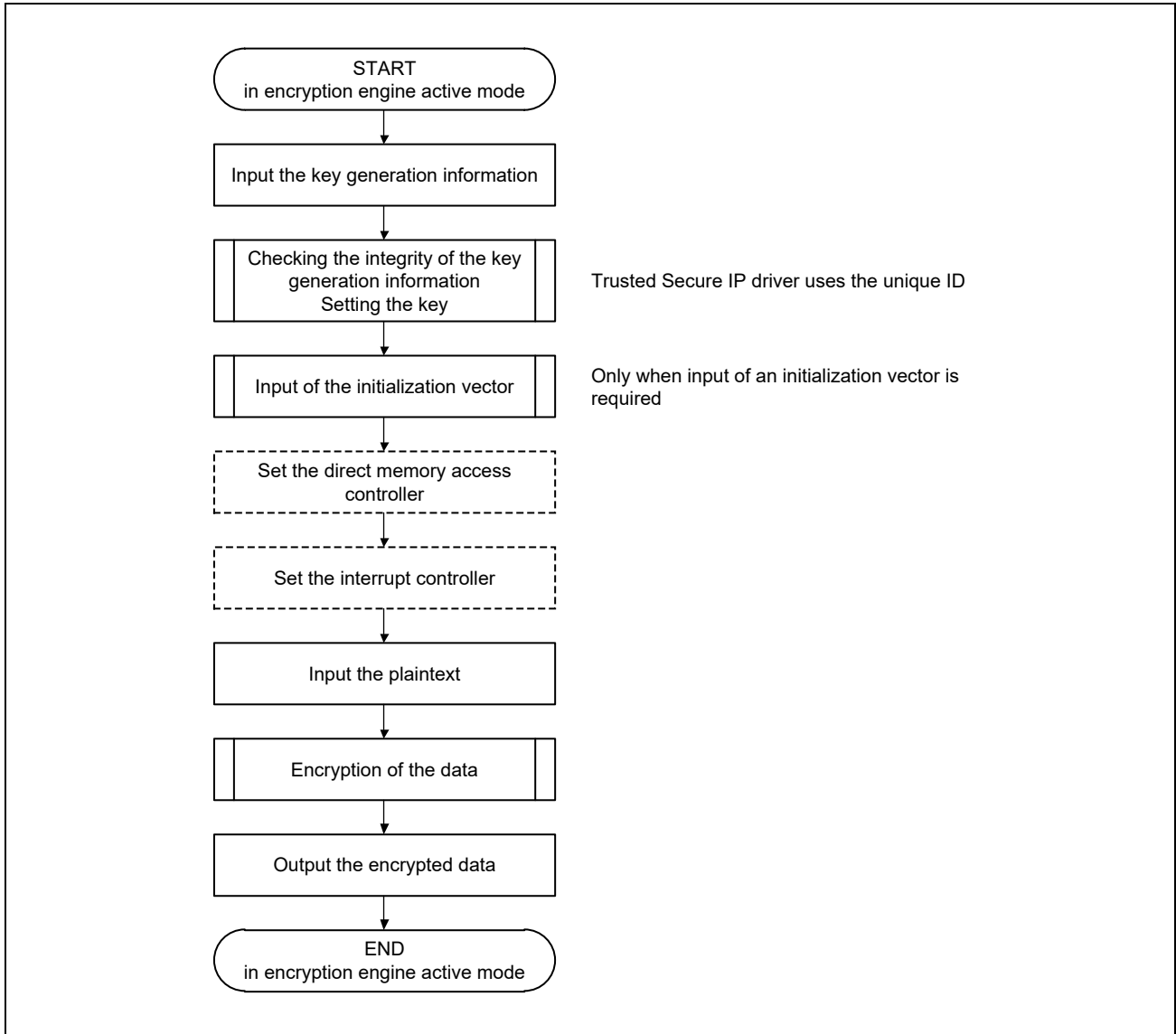

Figure 45.7 Encryption Flow Chart

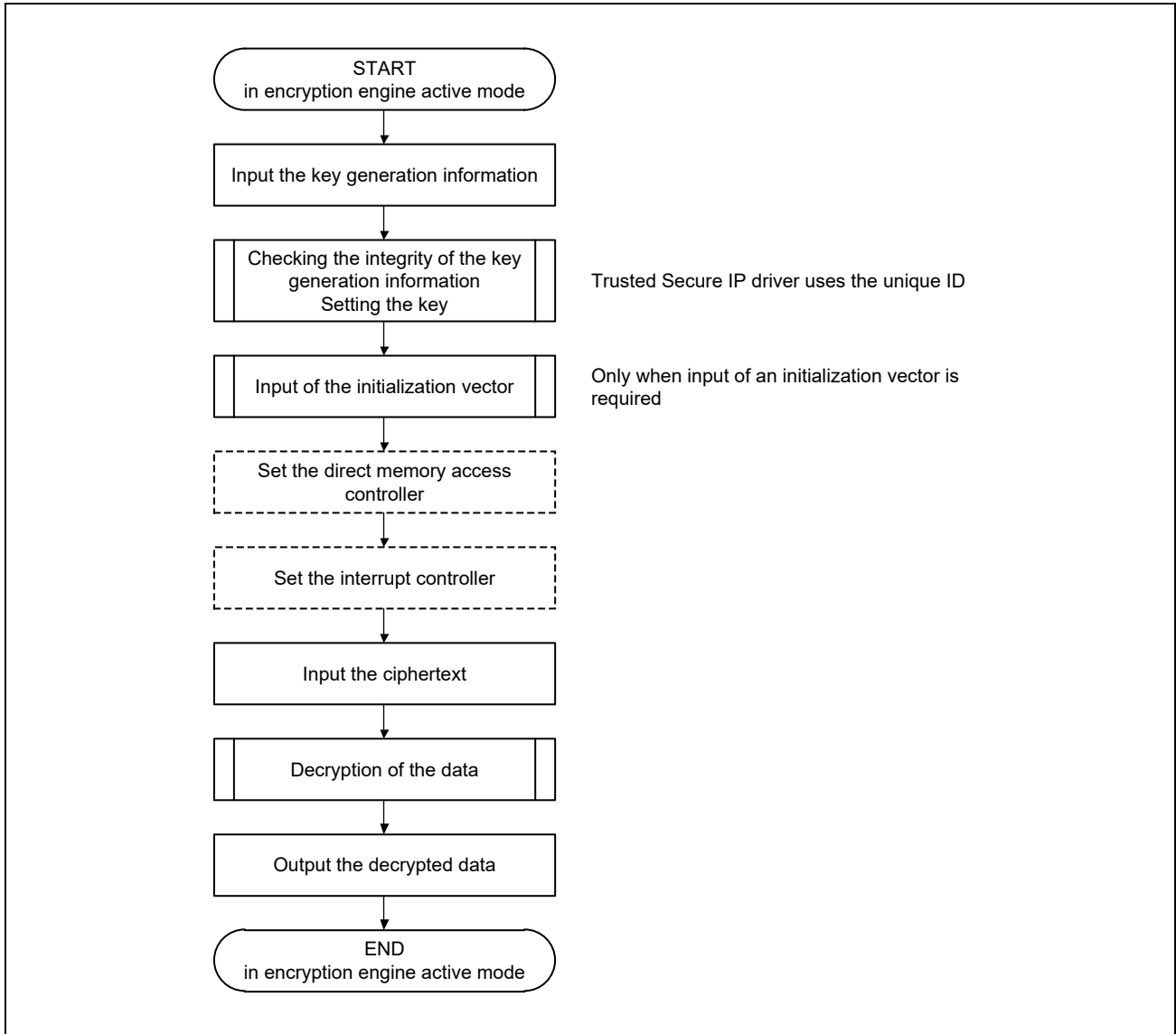

Figure 45.8 Decryption Flow Chart

45.2.5 Generating Key Generation Information (by Using Random Numbers)

Figure 45.9 shows the generating flow for the key generation information by using random numbers.

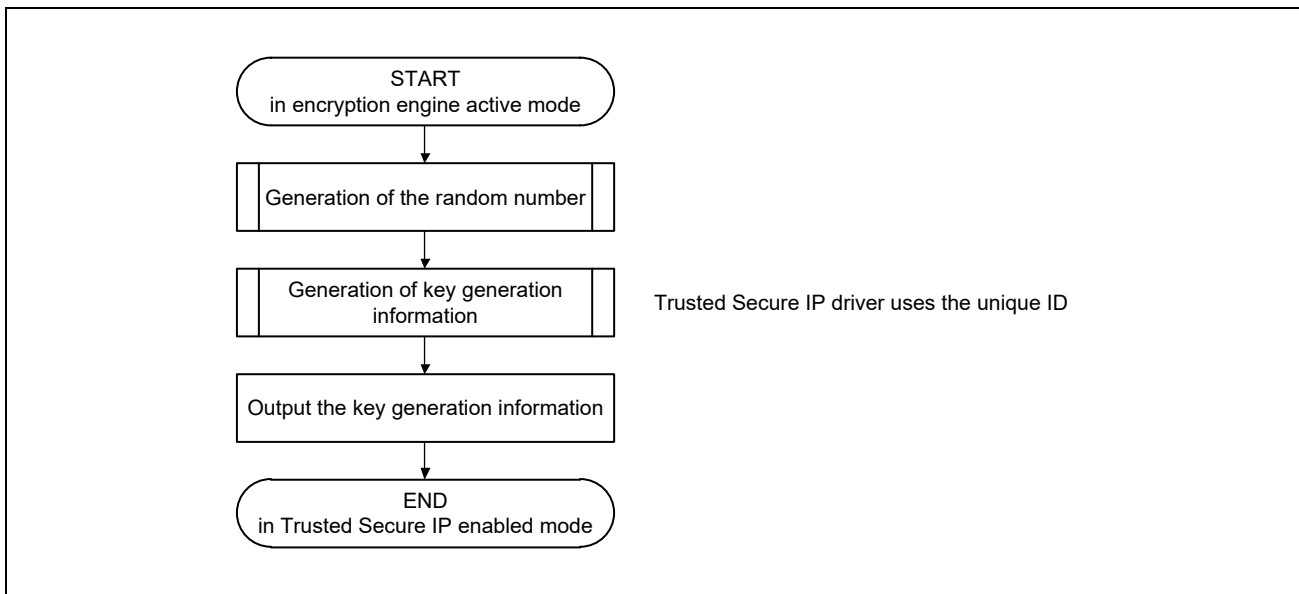

Figure 45.9 Key Generation Information Generating Flow Chart (Using Random Numbers)

45.2.6 Random Number Generation

Figure 45.10 shows the random number generation flow.

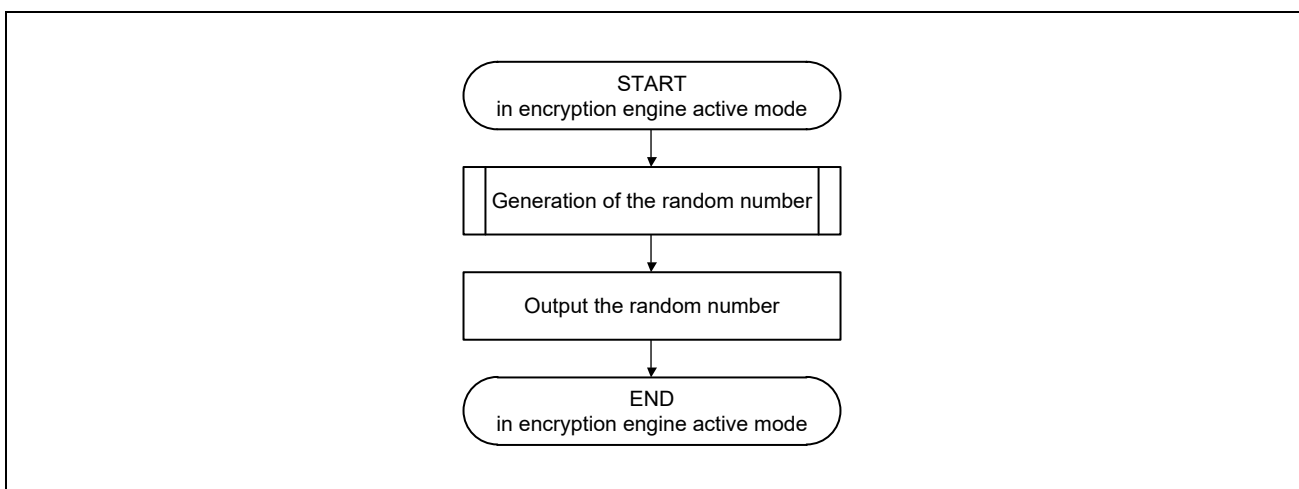

Figure 45.10 Random Number Generation Flow Chart

45.3 Interrupt

Table 45.2 lists the interrupt sources.

Trusted Secure IP driver uses interrupts caused by these interrupt sources. Do not change the setting of the interrupt controller corresponding to these interrupt sources.

Table 45.2 Trusted Secure IP Interrupt Sources

Name	Interrupt Source
PROC_BUSY	Procedure completion interrupt
ROMOK	Falsification detection interrupt
LONG_PLG	Calculation completion interrupt
WRRDY0	Write ready 0
WRRDY1	Write ready 1
WRRDY4	Write ready 4
RDRDY0	Read ready 0
RDRDY1	Read ready 1
IWRRDY	Integration write ready
IRDRDY	Integration read ready

45.4 Usage Notes

45.4.1 Trusted Secure IP Driver

Use of the Trusted Secure IP requires the Trusted Secure IP driver provided by Renesas Electronics. Please contact our sales office for information regarding the Trusted Secure IP driver.

48. Electrical Characteristics

48.1 Absolute Maximum Ratings

Table 48.1 Absolute Maximum Ratings

Item	Symbol	Value	Unit	
Power supply voltage (3.3 V)	PV _{DD} USB_V _{DD33}	-0.5 to +3.8	V	
Power supply voltage (1.8-V/3.3-V switchable)	SD0_PV _{DD} SD1_PV _{DD} SPI_PV _{DD}	-0.5 to +3.8	V	
Power supply voltage (1.8-V/ 2.5-V/ 3.3-V switchable)	PV _{DD182533_0/1}	-0.5 to +3.8	V	
Power supply voltage (1.8 V)	V _{DD18} PLL1_AV _{DD18} PLL23_AV _{DD18} PLL4_AV _{DD18} PLL6_AV _{DD18} USB_V _{DD18} ADC_AV _{DD18} OTP_V _{DD18}	-0.5 to +2.5	V	
DDR power supply voltage (DDR4/ DDR3L switchable)	DDR_V _{DDQ}	-0.5 to +2.5	V	
Power supply voltage (1.1-V)	V _{DD} PLL23_DV _{DD11}	-0.5 to +1.5	V	
Input voltage	3.3-V I/O input pins	—	-0.3 to 3.3-V power supply (PV _{DD} , USB_V _{DD33}) + 0.3	V
	1.8-V/3.3-V switchable I/O input pins	—	-0.3 to 1.8-V/3.3-V switchable power supply (SD0_PV _{DD} , SD1_PV _{DD} , SPI_PV _{DD}) + 0.3	V
	1.8-V/2.5-V/3.3-V switchable I/O input pins	—	-0.3 to 1.8-V/2.5-V/3.3-V switchable power supply (PV _{DD182533_0,1}) + 0.3	V
	1.8-V I/O input pins	—	-0.3 to 1.8-V power supply (V _{DD18} , CSI_V _{DD18} , USB_V _{DD18}) + 0.3	V
Operating temperature	Ambient temperature	T _a	-40°C to +85°C*1	°C
	Junction temperature	T _j	-40°C to +125°C	°C
Storage temperature	Ambient temperature	T _{stg}	-40°C to +150°C	°C

Note 1. If wider temp is required than this range, use case has to be investigated.

48.2 Power Supply

Table 48.2 Power Supply

Item	Symbol	Min.	Typ.	Max.	Unit	Remarks
Power supply voltage (3.3 V)	PV _{DD}	2.97	3.30	3.63	V	—
Power supply voltage (1.8 V)	V _{DD18} , ADC_AV _{DD18}	1.62	1.80	1.98	V	—
	OTP_V _{DD18}	1.65	1.80	1.95	V	—
Power supply voltage (1.1 V)	V _{DD}	1.05	1.10	1.15	V	—
Power supply voltage (USB)	USB_V _{DD33}	3.00	3.30	3.60	V	—
	USB_V _{DD18}	1.65	1.80	1.95	V	—
Power supply voltage (SD)	SD0_PV _{DD} ,	2.97	3.30	3.63	V	When 3.3 V is supplied
	SD1_PV _{DD}	1.70	1.80	1.95	V	When 1.8 V is supplied
Power supply voltage (SPI)	SPI_PV _{DD}	2.97	3.30	3.63	V	When 3.3 V is supplied
		1.70	1.80	1.95	V	When 1.8 V is supplied
Power supply voltage (Ether)	PV _{DD182533_0/1}	2.97	3.30	3.63	V	When 3.3 V is supplied
		2.25	2.50	2.75	V	When 2.5 V is supplied
		1.62	1.80	1.98	V	When 1.8 V is supplied
Power supply voltage (DDR)	DDR_V _{DDQ}	1.14	1.20	1.26	V	When using DDR4
		1.283	1.35	1.45	V	When using DDR3L
Power supply voltage (PLL)	PLL1_AV _{DD18} ,	1.62	1.80	1.98	V	—
	PLL23_AV _{DD18} ,					
	PLL4_AV _{DD18} ,					
	PLL6_AV _{DD18}					
	PLL23_DV _{DD11}	1.05	1.10	1.15	V	—

48.3 Power-On/Power-Off Sequence

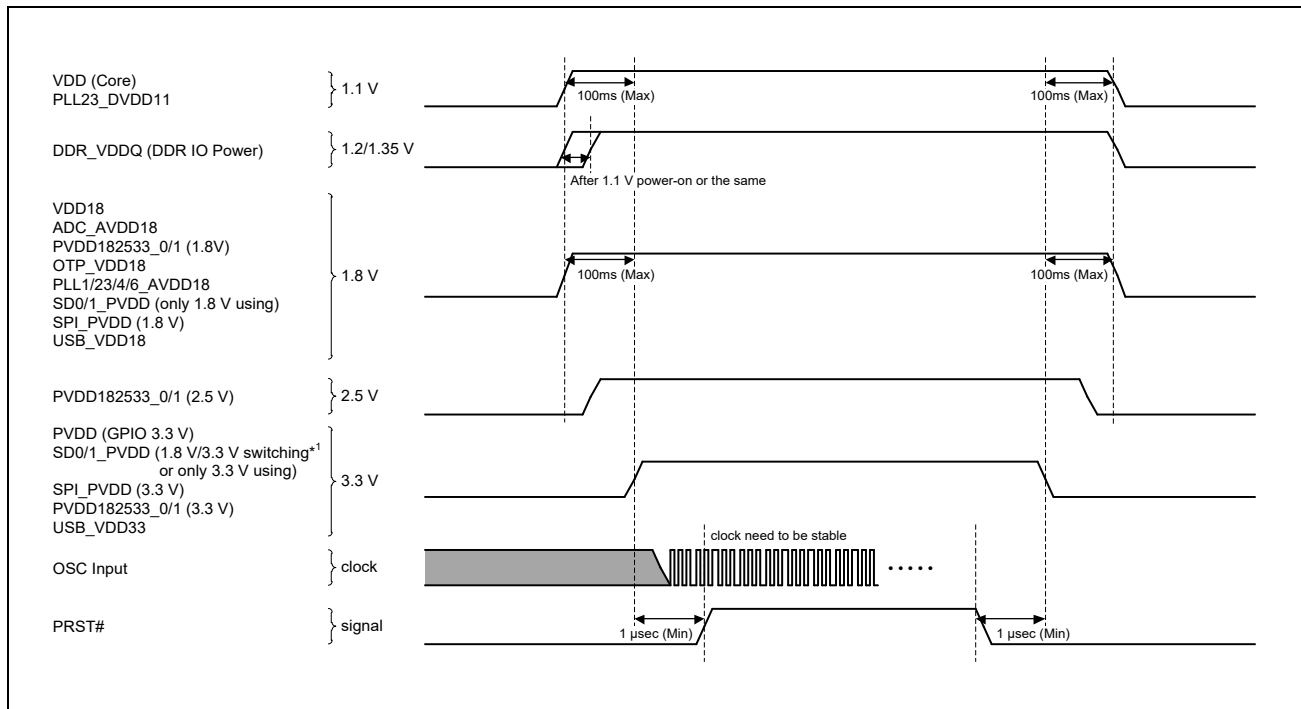

Figure 48.1 Power-On/Power-Off Sequence

NOTES

- Turn on 3.3 V after 1.1 V/1.8 V.

Note 1. About SD0/1_PVDD, especially in the case of switching between 1.8 V and 3.3 V at same power rail, 1.8-V power-on/off timing can also follow 3.3-V power rail sequence as shown in the **Figure 48.1**.
- Turn on the DDR IO power supply at the same time as or after the 1.1-V power supply.
- From first power rising start to last power rising end must be within 100 ms.
- The power-off sequence is the reverse of the power-on sequence (PRST# → Low ⇒ 3.3 V = OFF ⇒ Other = OFF)
- PRST# should be changed from Low to High after the 3.3-V power supply is turned on, after 1 μsec, and after the input clock from the oscillator stabilizes.
- Refer to SD0/1_PVDD when connecting eMMC.

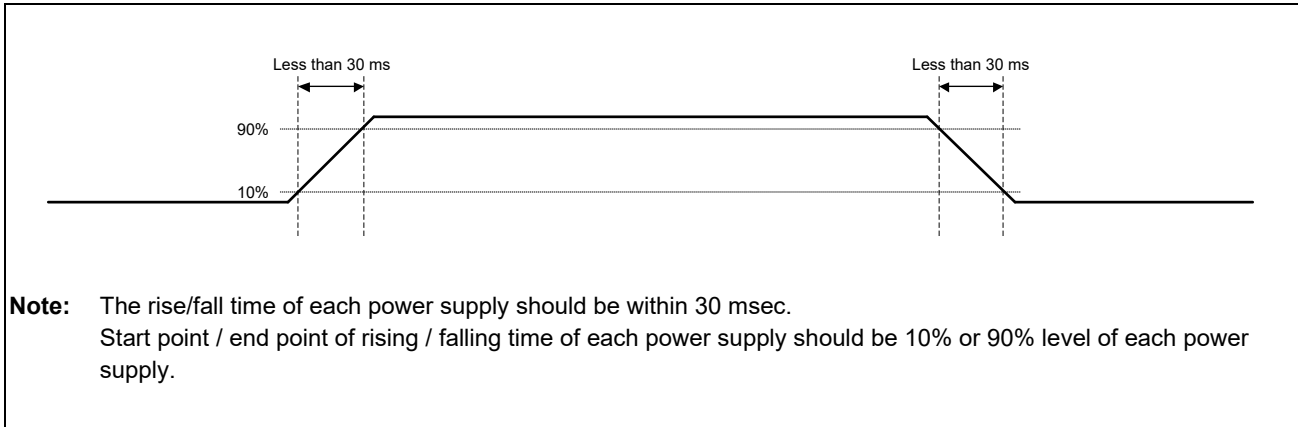

Figure 48.2 Power Up Time/Power Down Time (1)

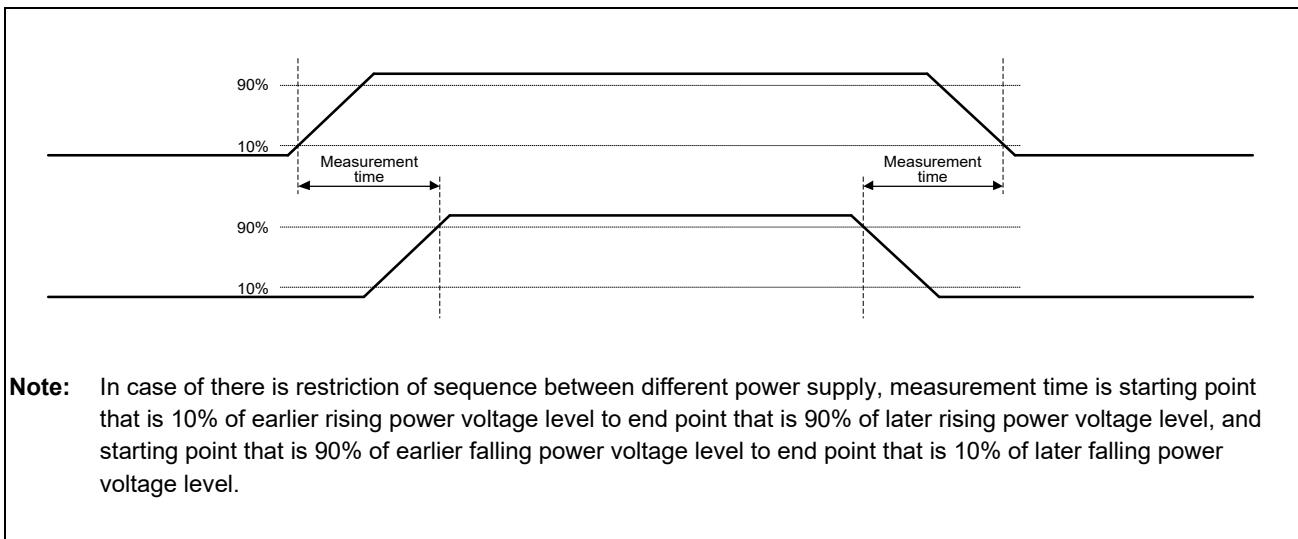

Figure 48.3 Power Up Time/Power Down Time (2)

48.4 DC Characteristics

Table 48.3 DC Characteristics (1) [3.3-V I/O]

Item	Symbol	Min.	Typ.	Max.	Unit	Remarks
High-level input voltage	V_{IH}	2	—	$PV_{DD} + 0.3$	V	
Low-level input voltage	V_{IL}	-0.3	—	0.8	V	
Hysteresis threshold ↑	V_{T+}	0.9	—	2.1	V	
Hysteresis threshold ↓	V_{T-}	0.7	—	1.9	V	
Input hysteresis voltage	V_{HYS}	0.306	—	0.420	V	
Output logic high voltage	V_{OH}	$PV_{DD} - 0.4$	—	PV_{DD}	V	
	($I_{OH} = -2mA$)					
	($I_{OH} = -4mA$)					
	($I_{OH} = -8mA$)					
	($I_{OH} = -12mA$)					
Output logic low voltage	V_{OL}	0	—	0.4	V	
	($I_{OL} = 2mA$)					
	($I_{OL} = 4mA$)					
	($I_{OL} = 8mA$)					
	($I_{OL} = 12mA$)					
Weak pull-up resistor (input mode)	R_{UP}	7K	—	100K	Ω	
Weak pull-down resistor (input mode)	R_{DN}	7K	—	100K	Ω	
Input leakage current	I_{LI}	—	—	5	μA	$0V \leq V_{in} \leq PV_{DD}$ In case of 3state buffer, the leak current when output mode OFF

Note: V_{in} means input voltage of external input pin.

Note: Schmitt can be used at only RIIC mode.

Table 48.4 DC Characteristics (2) [1.8-V I/O]

Item	Symbol	Min.	Typ.	Max.	Unit	Remarks
High-level input voltage	V_{IH}	$0.65 \times V_{DD18}$	—	$V_{DD18} + 0.3$	V	
Low-level input voltage	V_{IL}	-0.3	—	$0.35 \times V_{DD18}$	V	
Output logic high voltage	V_{OH}	$V_{DD18} - 0.4$	—	V_{DD18}	V	
	($I_{OH} = -2mA$)					
	($I_{OH} = -4mA$)					
	($I_{OH} = -8mA$)					
	($I_{OH} = -12mA$)					
Output logic low voltage	V_{OL}	0	—	0.4	V	
	($I_{OL} = 2mA$)					
	($I_{OL} = 4mA$)					
	($I_{OL} = 8mA$)					
	($I_{OL} = 12mA$)					

Table 48.5 DC Characteristics (3) [3.3-V Input]

Item	Symbol	Min.	Typ.	Max.	Unit	Remarks
High-level input voltage	V_{IH}	2.3	—	$PV_{DD} + 0.3$	V	
Low-level input voltage	V_{IL}	-0.3	—	0.8	V	
Hysteresis threshold ↑	V_{T+}	0.9	—	2.1	V	
Hysteresis threshold ↓	V_{T-}	0.7	—	1.9	V	
Input hysteresis voltage	V_{HYS}	0.306	—	0.420	V	

Table 48.6 DC Characteristics (4) [1.8-V Input]

Item	Symbol	Min.	Typ.	Max.	Unit	Remarks
High-level input voltage	V_{IH}	$0.65 \times V_{DD18}$	—	$V_{DD18} + 0.3$	V	
Low-level input voltage	V_{IL}	-0.3	—	$0.35 \times V_{DD18}$	V	

Table 48.7 DC Characteristics (5) [RGMII/MII]

Item	Symbol	Min.	Typ.	Max.	Unit	Remarks
Power supply voltage	$PV_{DD182533_n}$	2.97	3.3	3.63	V	3.3-V RGMII/MII
Input logic high	V_{IH}	2.6	—	—	V	
Input logic low	V_{IL}	—	—	0.7	V	
Output logic high voltage @ 7.7 mA	V_{OH}	2.1	—	3.6	V	
Output logic low voltage @ 9.3 mA	V_{OL}	0	—	0.5	V	
Power supply voltage	$PV_{DD182533_n}$	2.25	2.5	2.75	V	2.5-V RGMII/MII
Input logic high	V_{IH}	1.9	—	—	V	
Input logic low	V_{IL}	—	—	0.7	V	
Output logic high voltage	V_{OH}	2.0	—	$PV_{DD182533_n}$	V	
Output logic low voltage	V_{OL}	V_{SS}	—	0.4	V	
Power supply voltage	$PV_{DD182533_n}$	1.62	1.8	1.98	V	1.8-V RGMII/MII
Input logic high	V_{IH}	$0.7 \times PV_{DD182533_n}$	—	$PV_{DD182533_n} + 0.3$	V	
Input logic low	V_{IL}	$V_{SS} - 0.3$	—	$0.3 \times PV_{DD182533_n}$	V	
Output logic high @ $I_{OH} = 100 \mu A$	V_{OH}	$0.85 \times PV_{DD182533_n}$	—	$PV_{DD182533_n}$	V	
Output logic low @ $I_{OL} = 100 \mu A$	V_{OL}	V_{SS}	—	$0.15 \times PV_{DD182533_n}$	V	

Note: n = 0, 1

Table 48.8 DC Characteristics (6) [3.3 V I/O (SD, QSPI)]

Item	Symbol	Min.	Typ.	Max.	Unit	Remarks
High-level input voltage	V_{IH}	$0.625 \times SDn_PV_{DD}$	—	$SDn_PV_{DD} + 0.3$	V	
Low-level input voltage	V_{IL}	$SDn_PV_{DD} - 0.3$	—	$0.25 \times SDn_PV_{DD}$	V	
Output logic high voltage	V_{OH}	$0.75 \times SDn_PV_{DD}$	—	SDn_PV_{DD}	V	($\times 0.5$) ($\times 0.75$) ($\times 1.0$) ($\times 1.5$)
Output logic low voltage	V_{OL}	0	—	$0.125 \times SDn_PV_{DD}$	V	($\times 0.5$) ($\times 0.75$) ($\times 1.0$) ($\times 1.5$)

Table 48.9 DC Characteristics (7) [1.8 V I/O (SD, QSPI)]

Item	Symbol	Min.	Typ.	Max.	Unit	Remarks
High-level input voltage	V_{IH}	1.27	—	2.00	V	
Low-level input voltage	V_{IL}	$SDn_PV_{DD} - 0.3$	—	0.58	V	
Output logic high voltage	V_{OH}	$0.8 \times SDn_PV_{DD}$	—	SDn_PV_{DD}	V	
	($\times 0.5$)					
	($\times 0.75$)					
	($\times 1.0$)					
	($\times 1.5$)					
Output logic low voltage	V_{OL}	0	—	$0.2 \times SDn_PV_{DD}$	V	
	($\times 0.5$)					
	($\times 0.75$)					
	($\times 1.0$)					
	($\times 1.5$)					

Table 48.10 DC Characteristics(8) [I²C Open Drain 3.3 V I/O]

Item	Symbol	Min.	Typ.	Max.	Unit	Remarks
External pull-up supply	V_{VDDP}	2.7	—	PV_{DD}	V	
Input high voltage	V_{IH}	$0.7 \times V_{VDDP}$	—	$V_{VDDP} + 0.5$	V	
Input Low Voltage	V_{IL}	-0.5	—	$0.3 \times V_{VDDP}$	V	
Low level output current	I_{OL}	20	—	—	mA	$V_{OL} = 0.4$ V
Low level output voltage	V_{OL}	—	—	0.4	V	$V_{VDDP} > 2$ V
Input hysteresis	V_{HYST}	$0.1 \times V_{VDDP}$	—	—	mV	

Table 48.11 DC Characteristics (9) [1.2-V Input (DDR4)]

Item	Symbol	Min.	Typ.	Max.	Unit	Remarks
DC input high level	$V_{IH}(DC)$	$V_{REF} + 0.068$	—	—	V	
DC input low level	$V_{IL}(DC)$	—	—	$V_{REF} - 0.068$	V	
AC input high level	$V_{IH}(AC)$	$V_{REF} + 0.093$	—	—	V	
AC input Low level	$V_{IL}(AC)$	—	—	$V_{REF} - 0.093$	V	
DC differential input high	V_{IHdiff}	0.136	—	—	V	
DC differential input low	V_{ILdiff}	—	—	-0.136	V	
AC differential input high	$V_{IHdiff}(AC)$	$2 \times (V_{IH}(AC) - V_{REF})$	—	—	V	
AC differential input low	$V_{ILdiff}(AC)$	—	—	$2 \times (V_{REF} - V_{IL}(AC))$	V	
Differential input cross point voltage relative to $0.8 \times V_{DDIO}$ for DQS	$V_{IX}(DQS)$	-0.15	—	0.06	V	

Table 48.12 DC Characteristics (10) [1.35-V Input (DDR3L)]

Item	Symbol	Min.	Typ.	Max.	Unit	Remarks
DC input high level	$V_{IH}(DC)$	$V_{REF} + 0.09$	—	—	V	
DC input low level	$V_{IL}(DC)$	—	—	$V_{REF} - 0.09$	V	$V_{REF} = 0.5 \times$ DDR_V_{DDQ}
AC input high level	$V_{IH}(AC)$	$V_{REF} + 0.135$	—	—	V	
AC input low level	$V_{IL}(AC)$	—	—	$V_{REF} - 0.135$	V	$V_{REF} = 0.5 \times$ DDR_V_{DDQ}
DC differential input high	V_{IHdiff}	0.18	—	—	V	
DC differential input low	V_{ILdiff}	—	—	-0.18	V	
AC differential input high	$V_{IHdiff}(AC)$	$2 \times$ $(V_{IH}(AC) - V_{REF})$	—	—	V	
AC differential input low	$V_{ILdiff}(AC)$	—	—	$2 \times$ $(V_{REF} - V_{IL}(AC))$	V	$V_{REF} = 0.5 \times$ DDR_V_{DDQ}
Differential input cross point voltage relative to $0.5 \times DDR_V_{DDQ}$ for DQS	$V_{IX}(DQS)$	-0.075	—	0.075	V	

Table 48.13 DC Characteristics (11) [1.2-V Output (DDR4)]

Item	Symbol	Min.	Typ.	Max.	Unit	Remarks
DC output high measurement level (for IV curve linearity)	$V_{OH}(DC)$	—	$1.1 \times DDR_V_{DDQ}$	—	V	The swing of $\pm 0.15 \times$ DDR_V_{DDQ} is based on approximately 50% of the static single-ended output peak-to-peak swing with a driver impedance of 40Ω and an effective test load of 50Ω to $V_{TT} = DDR_V_{DDQ}$.
DC output mid measurement level (for IV curve linearity)	$V_{OM}(DC)$	—	$0.8 \times DDR_V_{DDQ}$	—	V	
DC output low measurement level (for IV curve linearity)	$V_{OL}(DC)$	—	$0.5 \times DDR_V_{DDQ}$	—	V	
AC output high measurement level (for output slew rate)	$V_{OH}(AC)$	—	$0.85 \times$ DDR_V_{DDQ}	—	V	
AC output low measurement level (for output slew rate)	$V_{OL}(AC)$	—	$0.55 \times$ DDR_V_{DDQ}	—	V	

Table 48.14 DC Characteristics (12) [1.35-V Output (DDR3L)]

Item	Symbol	Min.	Typ.	Max.	Unit	Remarks
DC output high measurement level (for IV curve linearity)	$V_{OH}(DC)$	—	$0.8 \times DDR_V_{DDQ}$	—	V	The swing of $\pm 0.1 \times$ DDR_V_{DDQ} is based on approximately 50% of the static single-ended output high or low swing with a driver impedance of 40Ω and an effective test load of 25Ω to $V_{TT} =$ $DDR_V_{DDQ}/2$.
DC output mid measurement level (for IV curve linearity)	$V_{OM}(DC)$	—	$0.5 \times DDR_V_{DDQ}$	—	V	
DC output low measurement level (for IV curve linearity)	$V_{OL}(DC)$	—	$0.2 \times DDR_V_{DDQ}$	—	V	
AC output high measurement level (for output slew rate)	$V_{OH}(AC)$	—	$V_{TT} + 0.1 \times$ DDR_V_{DDQ}	—	V	
AC output low measurement level (for output slew rate)	$V_{OL}(AC)$	—	$V_{TT} - 0.1 \times$ DDR_V_{DDQ}	—	V	

Table 48.15 DC Characteristics (13) [DDR4 Cross Point Voltage for Differential Output Signals (CK/DQS)]

Item	Symbol	Min.	Typ.	Max.	Unit	Remarks
Differential output cross point voltage relative to $0.67 \times DDR_V_{DDQ}$	$V_{OX}(CK/DQS)$	-0.06	—	0.06	V	

Table 48.16 DC Characteristics (14) [DDR3L Cross Point Voltage For Differential Output Signals (CK/DQS)]

Item	Symbol	Min.	Typ.	Max.	Unit	Remarks
Differential output cross point voltage relative to $0.5 \times \text{DDR_VDDQ}$	$V_{OX}(\text{CK/DQS})$	-0.1	—	0.1	V	

Table 48.17 DC Characteristics (15) [USB 2.0]

Item	Symbol	Min.	Typ.	Max.	Unit	Remarks
Input levels for low/full speed						
High (driven)	V_{IH}	2.0	—	—	V	
Low	V_{IL}	—	—	0.8	V	
Differential input sensitivity	V_{DI}	0.2	—	—	V	
Differential common mode range	V_{CM}	0.8	—	2.5	V	
Input levels for high speed						
High-speed squelch detection threshold (differential signal amplitude)	V_{HSSQ}	100	—	150	mV	
High-speed data signaling common mode voltage range (guideline for receiver)	V_{HSCM}	-50	—	500	mV	
Output levels for low/full speed						
Low	V_{OL}	0.0	—	0.3	V	
High (driven)	V_{OH}	2.8	—	3.6	V	
Output signal crossover voltage	V_{CRS}	1.3	—	2.0	V	
Output levels for high-speed						
High-speed idle level	V_{HSOI}	-10.0	—	10.0	mV	
High-speed data signaling high	V_{HSOH}	360	—	440	mV	
High-speed data signaling low	V_{HSOL}	-10.0	—	10.0	mV	
Chirp J level (differential voltage)	V_{CHIRPJ}	700	—	1100	mV	
Chirp K level (differential voltage)	V_{CHIRPK}	-900	—	-500	mV	

Table 48.18 DC Characteristics (16) [ADC]

Item	Symbol	Min.	Typ.	Max.	Unit	Remarks
Resolution	—	—	12	—	Bit	
Analog input channel	—	—	—	2	Channel	
Analog input range	A_{IN}	V_{SS}	—	ADC_AV_{DD18}	V	
Differential non-linearity	DNL	—	—	± 3.0	LSB	
Integral non-linearity	INL	—	—	± 6.0	LSB	
Full-scale error	—	—	± 10	± 20	LSB	
Offset error	—	—	± 10	± 20	LSB	
Analog input capacitance	C_{IN}	—	—	12.5	pF	
Analog input resistance	R_{IN}	—	—	1754	Ω	
External capacitance	C_{EXT}	—	—	(*)	pf	
External resistance	R_{EXT}	—	—	(*)	Ω	

Note 1. Refer to **Figure 48.4** for C_{ext} and R_{ext} .

The C_{ext} and R_{ext} need to satisfy the sampling time.

A/D conversion time = sampling time (6T to 2800T) + 14T.

T stands for the cycle of ADIVCLK (20 MHz).

If A/D conversion is performed with the minimum conversion time, the sampling time must be 6T.

(Minimum conversion time per channel is 1 μs when A/D conversion clock ADIVCLK is 20 MHz.)

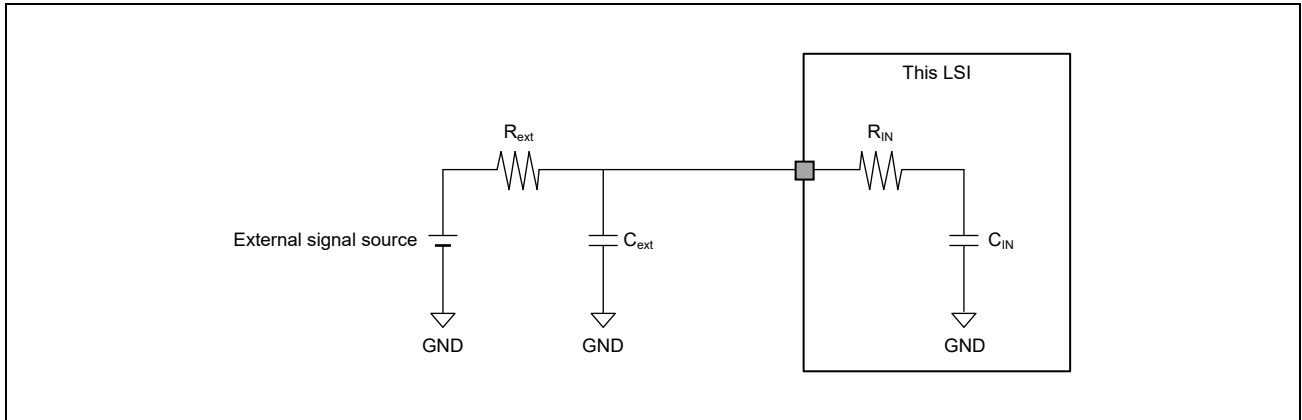

Figure 48.4 Analog Input Equivalent Circuit

Table 48.19 DC Characteristics (17) [Current Consumption]

Item	Power rail symbol	Max Current	Unit	Remarks
Power Supply voltage(3.3V)	PV _{DD}	430	mA	PV _{DD} =3.6V
Power Supply voltage(1.8V)	V _{DD18}	20	mA	V _{DD18} =1.98V
	OTP_AV _{DD18}	20	mA	OTP_V _{DD18} =1.95V
	ADC_AV _{DD18}	10	mA	ADC_AV _{DD18} =1.98V
Power Supply voltage(1.1V)	V _{DD}	2010	mA	V _{DD} =1.15V, Condition: AX45MP, Dhystone
Power supply voltage (USB/3.3V)	USB_V _{DD33}	20	mA	USB_V _{DD33} =3.6V
Power supply voltage (USB/1.8V)	USB_V _{DD18}	140	mA	USB_V _{DD18} =1.95V
Power supply voltage (SD/3.3V)	SD0_PV _{DD}	260	mA	SD0_PV _{DD} =3.63V
	SD1_PV _{DD}	170	mA	SD1_PV _{DD} =3.63V
Power supply voltage (SD/1.8V)	SD0_PV _{DD}	110	mA	SD0_PV _{DD} =1.95V
	SD1_PV _{DD}	70	mA	SD1_PV _{DD} =1.95V
Power supply voltage (SPI/3.3V)	SPI_PV _{DD}	50	mA	SPI_PV _{DD} =3.63V
Power supply voltage (SPI/1.8V)	SPI_PV _{DD}	100	mA	SPI_PV _{DD} =1.95V
Power supply voltage (Ether/3.3V)	PV _{DD182533_n}	380	mA	PV _{DD182533_n} =3.63V when 2 channels are in use
Power supply voltage (Ether/2.5V)	PV _{DD182533_n}	240	mA	PV _{DD182533_n} =2.75V when 2 channels are in use
Power supply voltage (Ether/1.8V)	PV _{DD182533_n}	140	mA	PV _{DD182533_n} =1.98V when 2 channels are in use
Power supply voltage (DDR/1.2V)	DDR_V _{DDQ}	220	mA	DDR_V _{DDQ} =1.26V
Power supply voltage (DDR/1.35V)	DDR_V _{DDQ}	210	mA	DDR_V _{DDQ} =1.45V
Power supply voltage (PLL/1.8V)	PLL1_AV _{DD18}	10	mA	PLL1_AV _{DD18} =1.98V
	PLL23_AV _{DD18}	20	mA	PLL23_AV _{DD18} =1.98V
	PLL4_AV _{DD18}	10	mA	PLL4_AV _{DD18} =1.98V
	PLL6_AV _{DD18}	10	mA	PLL6_AV _{DD18} =1.98V
Power supply voltage (PLL/1.1V)	PLL23_DV _{DD11}	20	mA	PLL23_DV _{DD11} =1.15V

Note: T_j = 125°C, n = 0, 1

48.5 AC Characteristics

Conditions: $V_{DD} = PLL23_DV_{DD11} = 1.1 \pm 0.05 \text{ V}$,
 $PLL1_AV_{DD18} = PLL23_AV_{DD18} = PLL4_AV_{DD18} = PLL6_AV_{DD18} = 1.8 \pm 0.18 \text{ V}$,
 $ADC_AV_{DD18} = V_{DD18} = 1.8 \pm 0.18 \text{ V}$, $OTP_V_{DD18} = 1.8 \text{ V} \pm 0.15 \text{ V}$,
 $USB_V_{DD18} = 1.8 \pm 0.15 \text{ V}$,
 $PV_{DD} = 3.3 \pm 0.33 \text{ V}$, $USB_V_{DD33} = 3.3 \pm 0.3 \text{ V}$, $DDR_V_{DDQ} = 1.2 \pm 0.06 \text{ V}/1.283 \text{ to } 1.45 \text{ V}$,
 $SPI_PV_{DD} = SDn_PV_{DD} (n = 0, 1) = 3.3 \pm 0.33 \text{ V}/1.70 \text{ to } 1.95 \text{ V}$,
 $PV_{DD182533_n} (n = 0, 1) = 3.3 \pm 0.33 \text{ V}/2.5 \pm 0.25 \text{ V}/1.8 \pm 0.18 \text{ V}$, $V_{SS} = 0 \text{ V}$,
 $T_a = -40 \text{ to } +85^\circ\text{C}$, $T_j = -40 \text{ to } +125^\circ\text{C}$

48.5.1 Clock Timing

Table 48.20 Clock Timing Table

Item	Symbol	Min.	Max.	Unit	Figures
EXCLK clock input frequency	f_{EX}	24 – 50ppm*1	24 + 50ppm*1	MHz	Figure 48.5
EXCLK clock input cycle time	t_{EXcyc}	41.67	41.67	ns	
AUDIO_CLK1, AUDIO_CLK2 clock input frequency (external clock is input)	f_{EX}	10	50	MHz	
AUDIO_CLK1, AUDIO_CLK2 clock input cycle time (external clock is input)	t_{EXcyc}	20	100	ns	
EXCLK, AUDIO_CLK1, AUDIO_CLK2 clock input low level pulse width	t_{EXL}	0.4	0.6	t_{EXcyc}	
EXCLK, AUDIO_CLK1, AUDIO_CLK2 clock input high level pulse width	t_{EXH}	0.4	0.6	t_{EXcyc}	
EXCLK, AUDIO_CLK1, AUDIO_CLK2 clock input rise time	t_{EXr}	—	4	ns	
EXCLK, AUDIO_CLK1, AUDIO_CLK2 clock input fall time	t_{EXf}	—	4	ns	
Oscillator stabilization time	t_{OSC}	—	1	ms	Figure 48.6,
Mode hold time	t_{MDH}	—	100	ns	Figure 48.7
Mode setup time	t_{MDS}	—	100	ns	

Note 1. When using RGMII interface. If not using RGMII mode, this spec is $\pm 100 \text{ ppm}$.

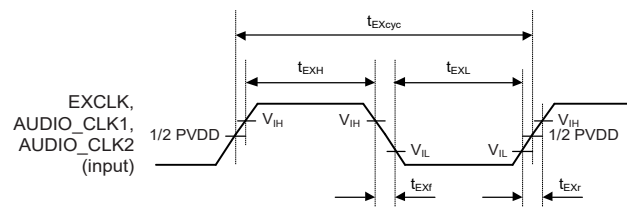

Note: When the clock is input on the EXCLK, AUDIO_CLK1 or AUDIO_CLK2

Figure 48.5 EXCLK, AUDIO_CLK1 and AUDIO_CLK2 Clock Input Timing

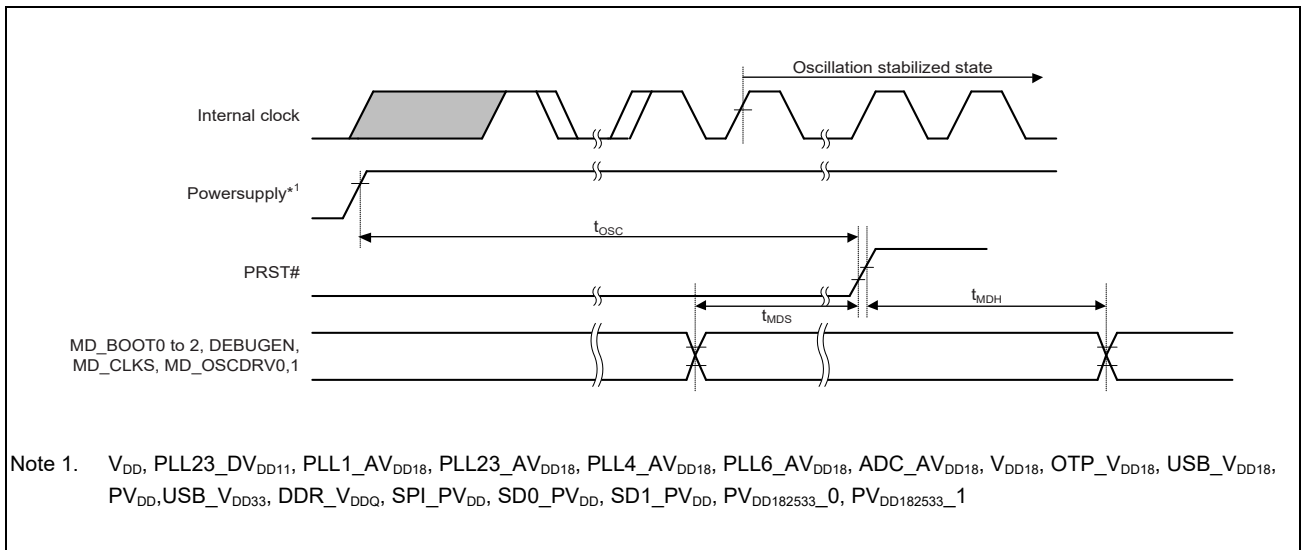

Figure 48.6 Power-On Oscillation Settling Time

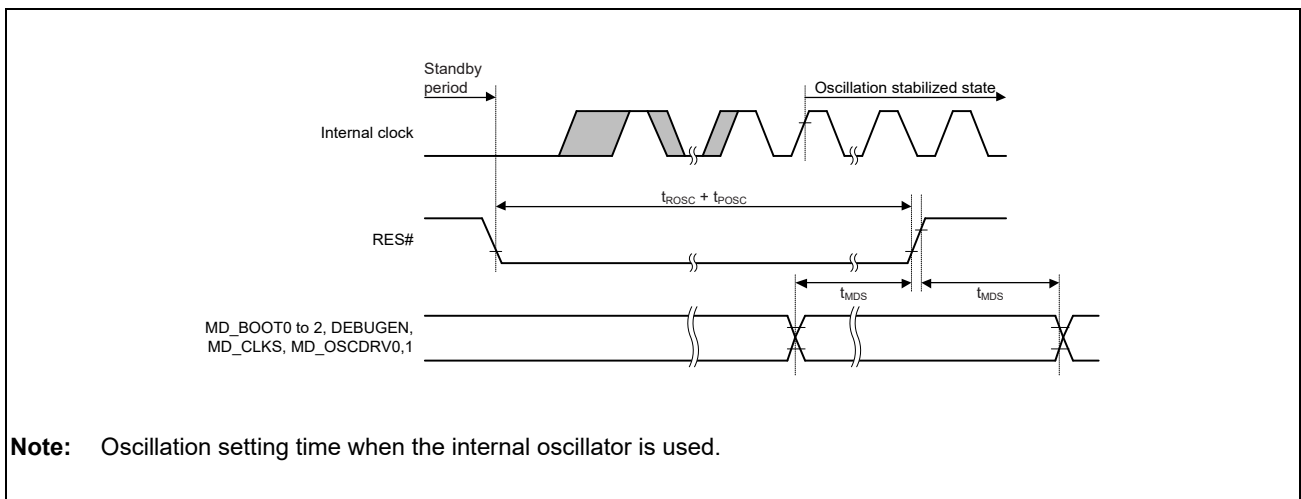

Figure 48.7 Oscillation Settling Time on Return from Standby (Return by Reset)

48.5.2 SDHI Access Timing

48.5.2.1 SDHI Access Timing (SDR 3.3-V)

Table 48.21 SDHC AC Access Timing (SDR at 3.3-V Operation)

Item	Symbol	Default Speed Mode (16.67 MHz)		High Speed Mode (33.33 MHz)		Unit	Figures
		Min.	Max.	Min.	Max.		
SD_CLK clock cycle	t_{SDCYC}	60.00	—	30.0	—	ns	Figure 48.8
SD_CLK clock high level width	t_{SDWH}	23.50	—	13.50	—	ns	
SD_CLK clock low level width	t_{SDWL}	23.50	—	13.50	—	ns	
SD_CLK clock rise time	t_{SDLH}	—	10	—	3	ns	
SD_CLK clock fall time	t_{SDHL}	—	10	—	3	ns	
SD_CMD,SD_DATA output delay	t_{SDODLY}	-4.50	4.0	-4.50	4.0	ns	
SD_CMD,SD_DATA input set up time	t_{SDIS}	5.5	—	5.5	—	ns	
SD_CMD,SD_DATA input hold time	t_{SDIH}	2.0	—	2.0	—	ns	
SD_CMD,SD_DATA input data width	t_{SDIDW}	—	—	—	—	ns	

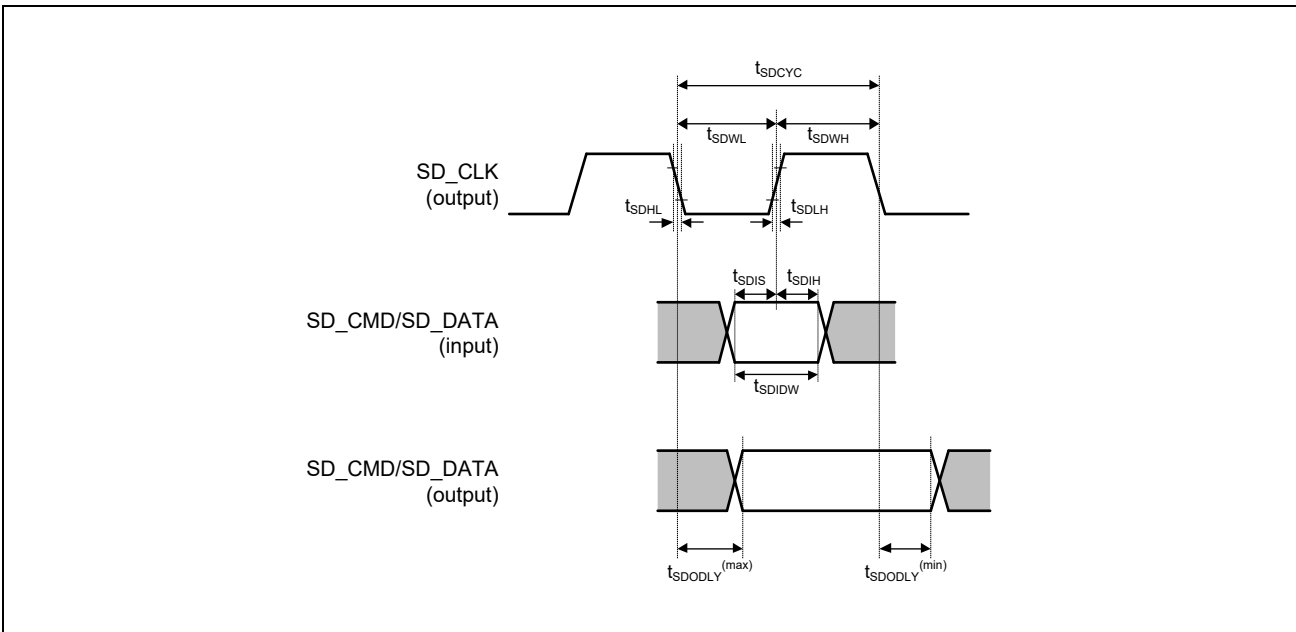

Figure 48.8 SDHC Interface Timing (SDR 3.3-V Power Supply)

NOTE

The disclosure of other characteristics of the SD interface needs the conclusion of the following agreement.

- SD Host/Ancillary Product License Agreement (SD HALA)

For details, contact your local sales representatives.

48.5.3 eMMC Access Timing

48.5.3.1 eMMC Host Interface Timing (Default)

Table 48.22 eMMC Host Interface Timing (MMC Default 3.3-V Power Supply)

Item	Symbol	Min.	Max.	Unit	Figures
SD0_CLK clock cycle	t_{MMCPP}	40.00	—	ns	Figure 48.9
SD0_CLK clock high level width	t_{MMCWH}	18.50	—	ns	
SD0_CLK clock low level width	t_{MMCWL}	18.50	—	ns	
SD0_CLK clock rise time	t_{MMCLH}	—	3	ns	
SD0_CLK clock fall time	t_{MMCHL}	—	3	ns	
SD0_CMD/SDDAT output delay	$t_{MMCODLY}$	-4.50	4.0	ns	
SD0_CMD/SDDAT input set up time	t_{MMCISU}	5.5	—	ns	
SD0_CMD/SDDAT input hold time	t_{MMCIH}	2.0	—	ns	
SD0_CMD/SDDAT input data width	t_{MMCIDW}	—	—	ns	

Table 48.23 eMMC Host Interface Timing (MMC Default 1.8-V Power Supply)

Item	Symbol	Min.	Max.	Unit	Figures
SD0_CLK clock cycle	t_{MMCPP}	40.00	—	ns	Figure 48.9
SD0_CLK clock high level width	t_{MMCWH}	19.25	—	ns	
SD0_CLK clock low level width	t_{MMCWL}	19.25	—	ns	
SD0_CLK clock rise time	t_{MMCLH}	—	2.45	ns	
SD0_CLK clock fall time	t_{MMCHL}	—	2.45	ns	
SD0_CMD/SDDAT output delay	$t_{MMCODLY}$	-2.00	2.50	ns	
SD0_CMD/SDDAT input set up time	t_{MMCISU}	4.00	—	ns	
SD0_CMD/SDDAT input hold time	t_{MMCIH}	1.40	—	ns	
SD0_CMD/SDDAT input data width	t_{MMCIDW}	—	—	ns	

48.5.3.2 eMMC host interface timing (HS-SDR)

Table 48.24 eMMC Host Interface Timing (MMC HS-SDR 3.3-V Power Supply)

Item	Symbol	Min.	Max.	Unit	Figures
SD0_CLK clock cycle	t_{MMCPP}	30.00	—	ns	Figure 48.9
SD0_CLK clock high level width	t_{MMCWH}	13.50	—	ns	
SD0_CLK clock low level width	t_{MMCWL}	13.50	—	ns	
SD0_CLK clock rise time	t_{MMCLH}	—	3	ns	
SD0_CLK clock fall time	t_{MMCHL}	—	3	ns	
SD0_CMD/SDDAT output delay	t_{MMCODY}	-4.50	4.0	ns	
SD0_CMD/SDDAT input set up time	t_{MMCISU}	5.5	—	ns	
SD0_CMD/SDDAT input hold time	t_{MMCIH}	2.0	—	ns	
SD0_CMD/SDDAT input data width	t_{MMCIDW}	—	—	ns	

Table 48.25 eMMC Host Interface Timing (MMC HS-SDR 1.8-V Power Supply)

Item	Symbol	Min.	Max.	Unit	Figures
SD0_CLK clock cycle	t_{MMCPP}	20.00	—	ns	Figure 48.9
SD0_CLK clock high level width	t_{MMCWH}	9.25	—	ns	
SD0_CLK clock low level width	t_{MMCWL}	9.25	—	ns	
SD0_CLK clock rise time	t_{MMCLH}	—	2.45	ns	
SD0_CLK clock fall time	t_{MMCHL}	—	2.45	ns	
SD0_CMD/SDDAT output delay	t_{MMCODY}	-2.00	2.50	ns	
SD0_CMD/SDDAT input set up time	t_{MMCISU}	4.00	—	ns	
SD0_CMD/SDDAT input hold time	t_{MMCIH}	1.40	—	ns	
SD0_CMD/SDDAT input data width	t_{MMCIDW}	—	—	ns	

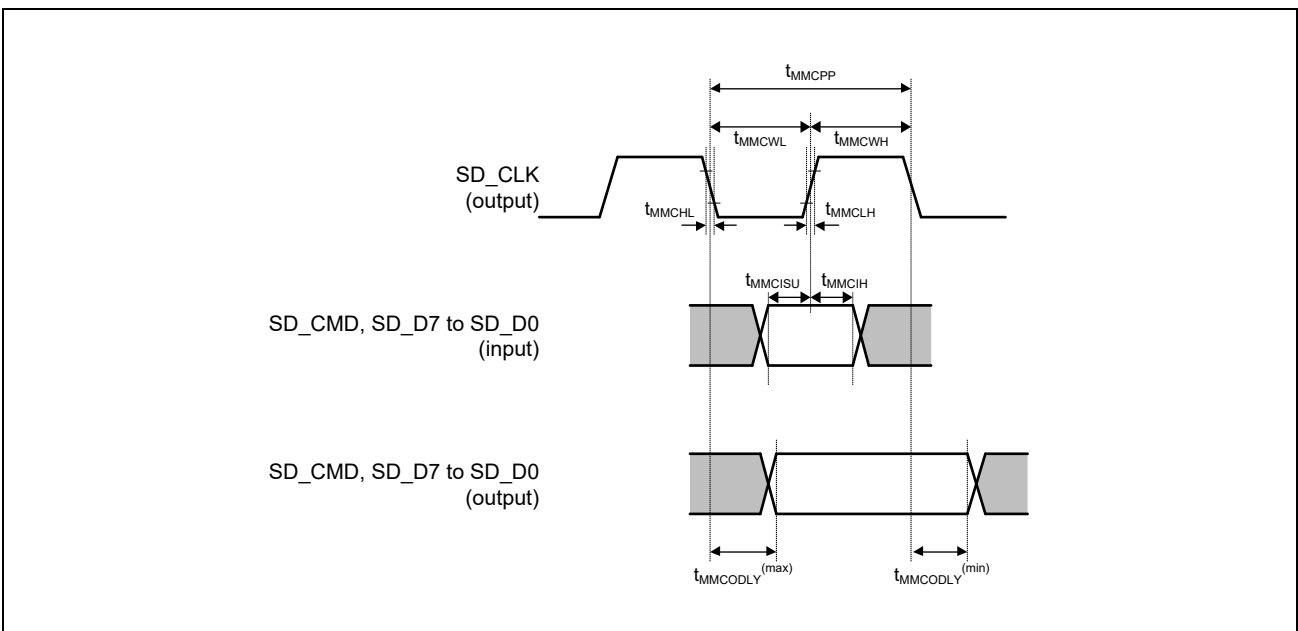

Figure 48.9 eMMC Host Interface Timing (MMC Default/HS-SDR 1.8-V/3.3-V Power Supply)

48.5.3.3 eMMC host interface timing (HS200)

Table 48.26 eMMC Host Interface Timing (HS200 1.8-V Power Supply Operation, Output Load 15 pF)

Item	Symbol	Min.	Max.	Unit	Figures
SD0_CLK clock cycle	t_{MMCPP}	7.50	15.0	ns	Figure 48.10
SD0_CLK clock high level width	t_{MMCWH}	3.20	—	ns	
SD0_CLK clock low level width	t_{MMCWL}	3.20	—	ns	
SD0_CLK clock rise time	t_{MMCLH}	—	1.22	ns	
SD0_CLK clock fall time	t_{MMCHL}	—	1.22	ns	
SD0_CMD/SDDAT output delay	$t_{MMCODLY}$	-1.50	1.75	ns	
SD0_CMD/SDDAT input set up time	t_{MMCISU}	—	—	ns	
SD0_CMD/SDDAT input hold time	t_{MMCIH}	—	—	ns	
SD0_CMD/SDDAT input data width	t_{MMCIDW}	4.31	—	ns	

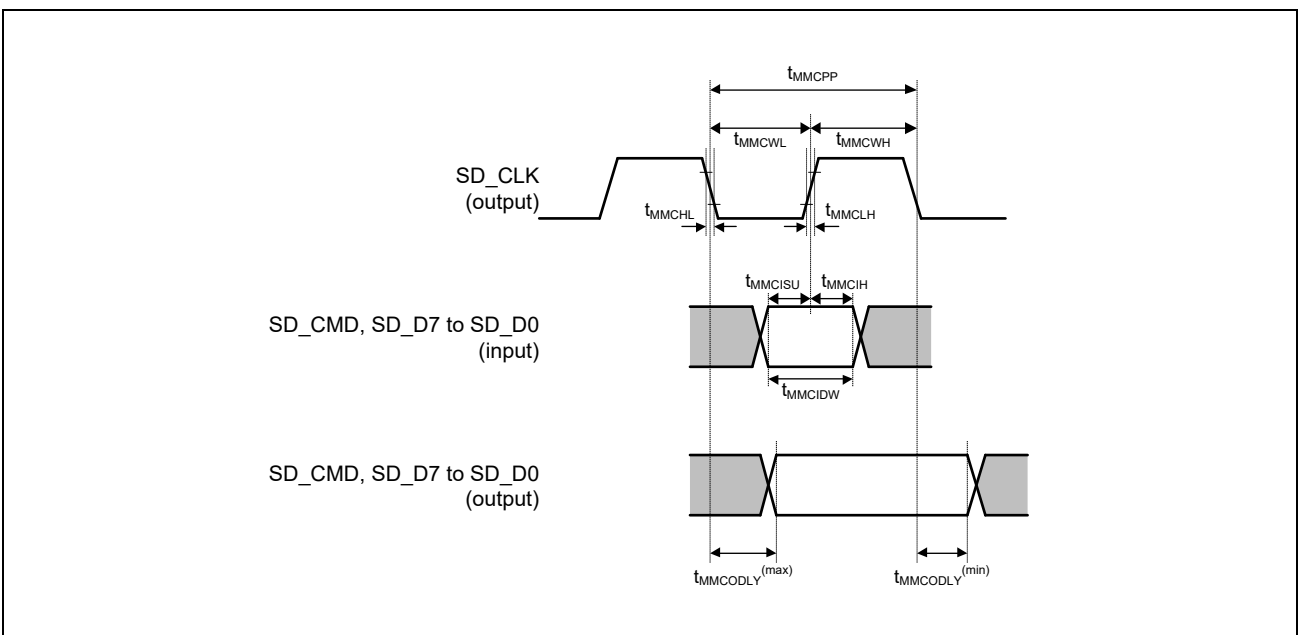

Figure 48.10 eMMC Host Interface (MMC Interface HS200 Mode 1.8-V Power Supply Selection)

48.5.4 USB 2.0 Host/Function Module Access Timing

48.5.4.1 USB 2.0 Low-Speed Access Timing

Table 48.27 USB Transceiver Timing (Low-Speed)

Item	Symbol	Min.	Max.	Unit	Figures
Rise time	t_{LR}	75	300	ns	Figure 48.11
Fall time	t_{LF}	75	300	ns	
Rise/fall time lag	t_{LR}/t_{LF}	80	125	%	

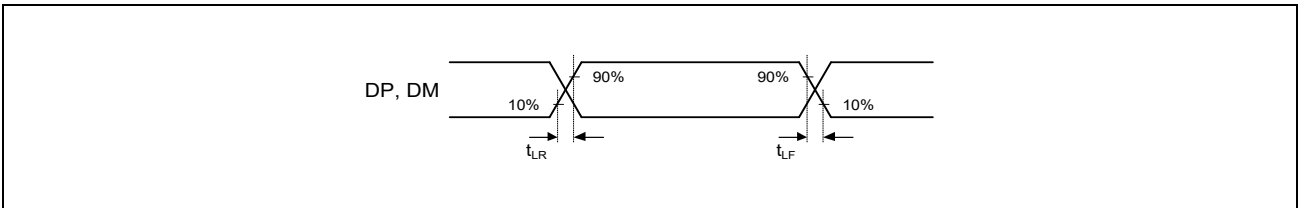

Figure 48.11 USB0_DP, USB1_DP, USB0_DM, and USB1_DM Output Timing (Low-Speed)

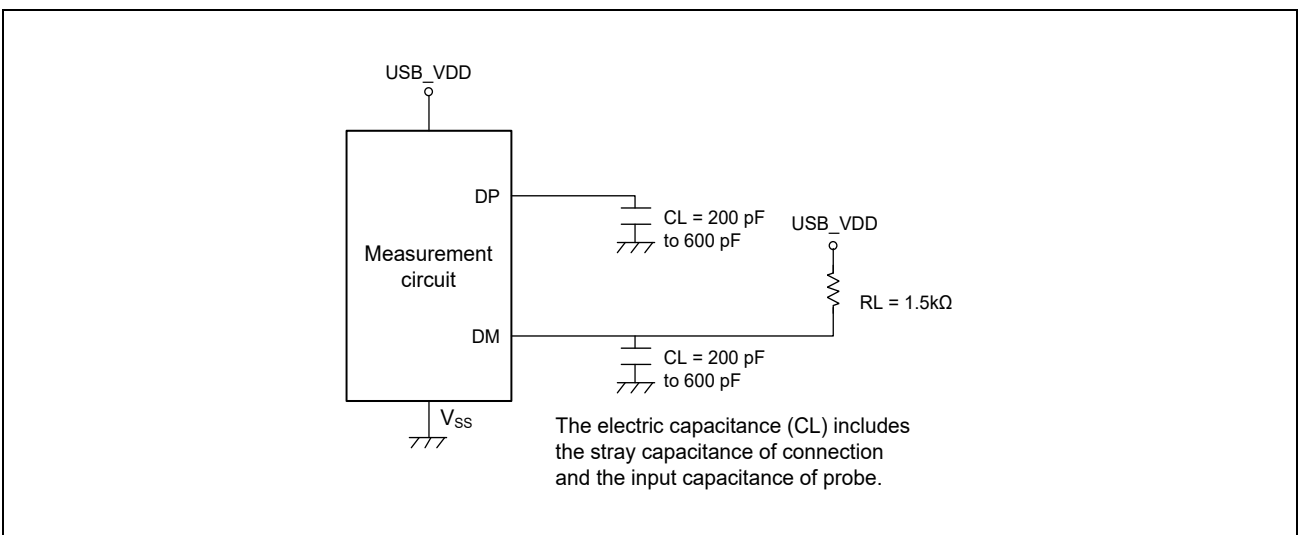

Figure 48.12 Measurement Circuit (Low-Speed)

48.5.4.2 USB 2.0 Full-Speed Access Timing

Table 48.28 USB Transceiver Timing (Full-Speed)

Item	Symbol	Min.	Max.	Unit	Figures
Rise time	t_{FR}	4	20	ns	Figure 48.13
Fall time	t_{FF}	4	20	ns	
Rise/fall time lag	t_{FR}/t_{FF}	90	111.11	%	

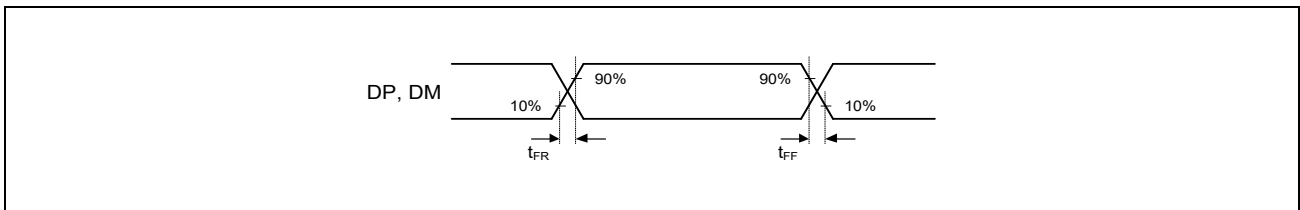

Figure 48.13 USB0_DP, USB1_DP, USB0_DM, and USB1_DM Output Timing (Full-Speed)

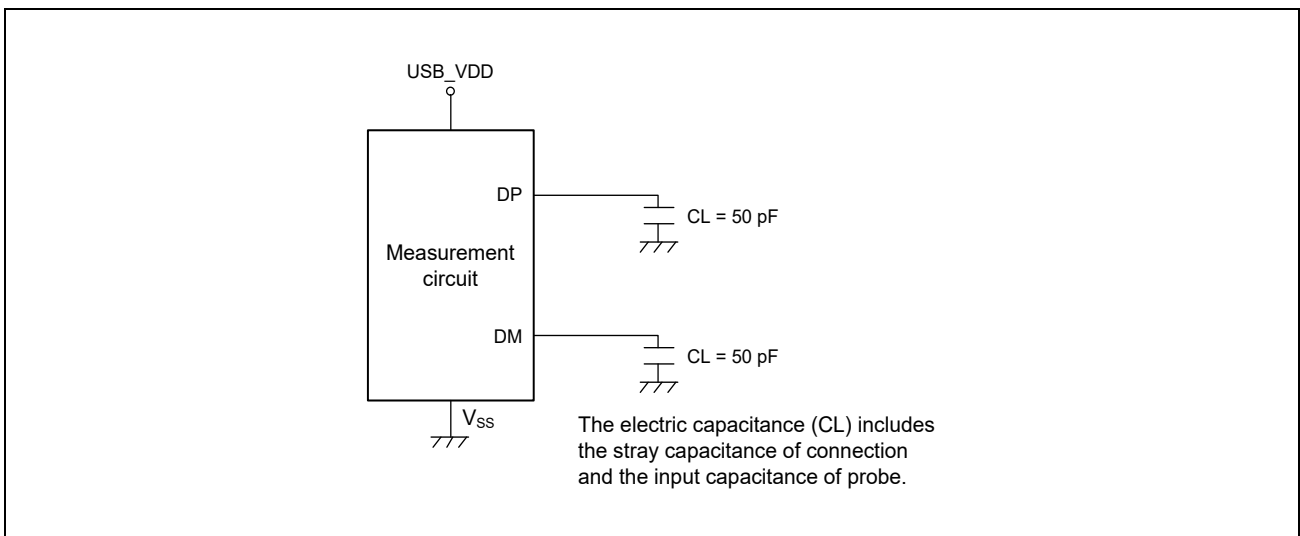

Figure 48.14 Measurement Circuit (Full-Speed)

48.5.4.3 USB 2.0 Hi-Speed Access Timing

Table 48.29 USB Transceiver Timing (Hi-Speed)

Item	Symbol	Min.	Max.	Unit	Figures
Rise edge rate	t_{HSR}	—	2133	V/ μ s	Figure 48.15
Fall edge rate	t_{HSF}	—	2133	V/ μ s	
Output driver resistance	Z_{HSDRV}	40.5	49.5	Ω	

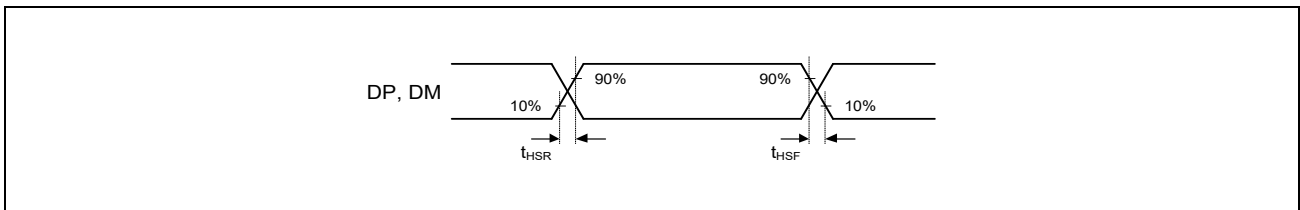

Figure 48.15 USB0_DP, USB1_DP, USB0_DM, and USB1_DM Output Timing (Hi-Speed)

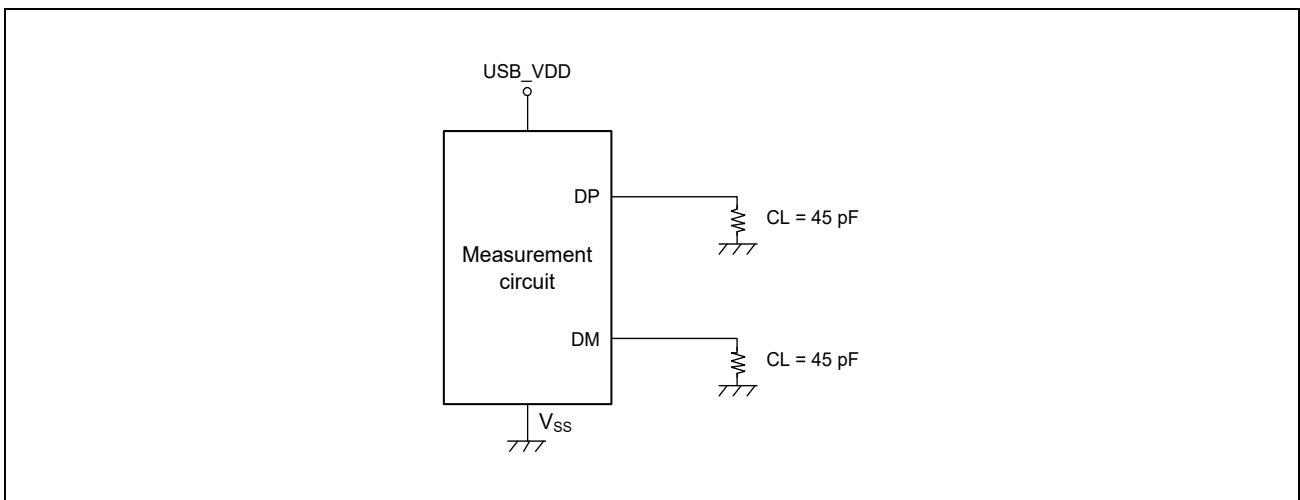

Figure 48.16 Measurement Circuit (Hi-Speed)

48.5.5 Ethernet Interface Access Timing

Table 48.30 Ethernet Interface Access Timing

Item	Symbol	Min.	Max.	Unit	Figures
MDC half cycle	t_{MDC}	0	300	ns	Figure 48.17
MDI setup time	$t_{MDIsetup}$	10	—	ns	
MDI hold time	$t_{MDIhold}$	10	—	ns	

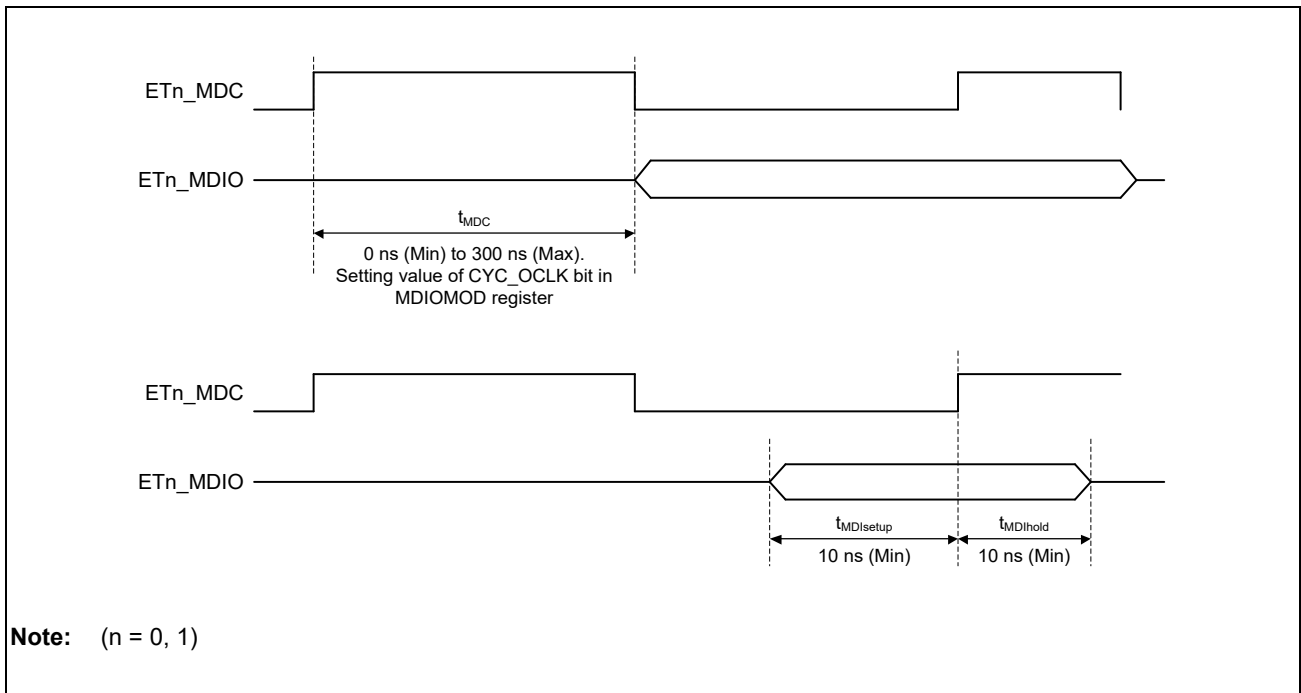

Figure 48.17 Management Interface

48.5.5.1 Ethernet-IF (Ether MII)

Table 48.31 Ethernet-IF Access Timing (Ether MII)

Item	Symbol	Min.	Max.	Unit	Figures	
Ether MII	ETH_GTXXC_TXC period	t_{Tcyc}	40	—	ns	Figure 48.18
	ETH_TXCTL output delay	t_{TEND}	0	25	ns	
	ETH_TXD3-0 output delay	t_{MTDd}	0	25	ns	
	ETH_RXC period	t_{Rcyc}	40	—	ns	
	ETH_RXDV setup time	t_{RDVs}	10	—	ns	
	ETH_RXDV hold time	t_{RDVh}	10	—	ns	
	ETH_RXD3-0 setup time	t_{MRDs}	10	—	ns	
	ETH_RXD3-0 hold time	t_{MRDh}	10	—	ns	
	ETH_RXER setup time	t_{RErs}	10	—	ns	
	ETH_RXER hold time	t_{RErh}	10	—	ns	

Note: I/O driving ability: 8 mA
CL = 8 pF

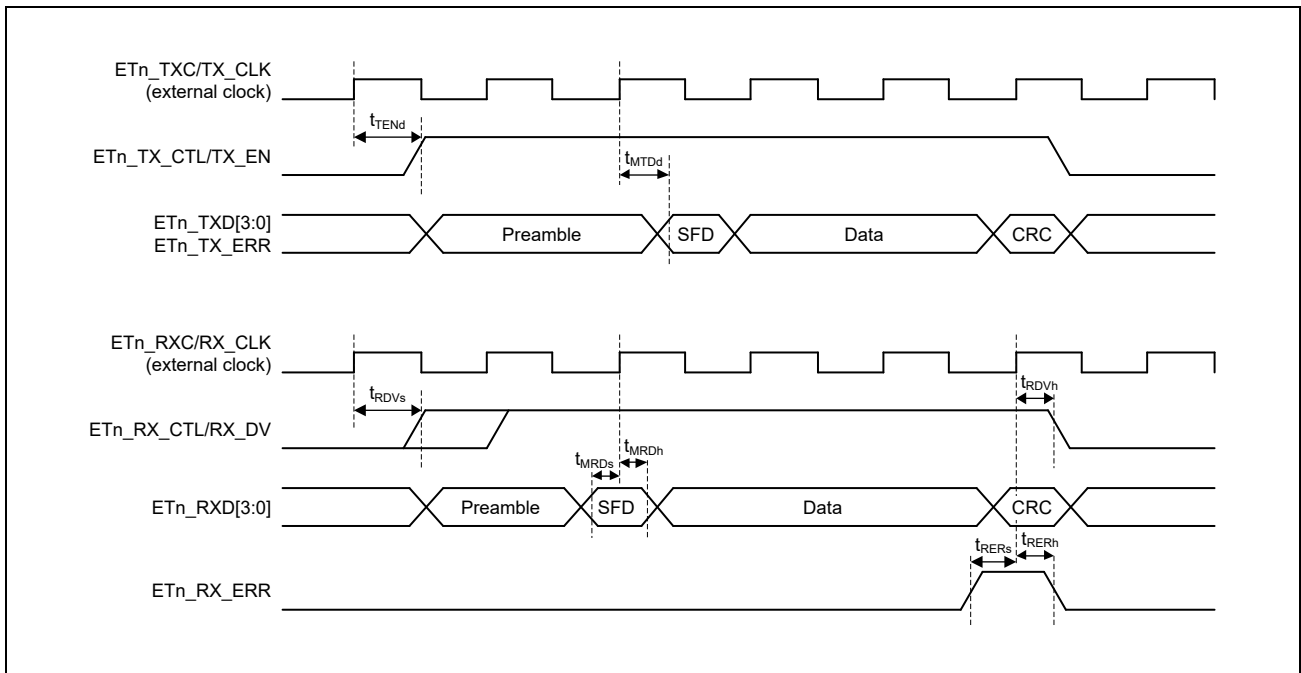

Figure 48.18 MII Transmission Timing

Validated with IEEE802.3 regulation.

The propagation delay for each twisted pair, measured from the MII connector to the PHY, shall not exceed 2.5 ns.

The variation in the propagation delay of the twisted pairs in a given cable bundle, measured from the MII connector to the PHY, shall not exceed 0.1 ns.

48.5.5.2 Ethernet-IF (Ether RGMII)

Table 48.32 Ethernet-IF Access Timing (Ether RGMII)

Item	Symbol	Min.	Typ.	Max.	Unit	capaci- tance	Remarks	Figures
Ether RGMII	Data to clock output skew @ transmitter	T_{skewT}	-500	0	500	ps	8 pF	Tx RGMII Figure 48.19
	Data to clock input skew @ receiver	T_{skewR}	1	1.8	2.6	ns	8 pF	
	Data to clock output setup @ transmitter integrated delay	T_{setupT}	1.2	2.0	—	ns	8 pF	Rx RGMII-ID Figure 48.20
	Clock to data output hold @ transmitter integrated delay	T_{holdT}	1.2	2.0	—	ns	8 pF	
	Data to clock input setup @ receiver integrated delay	T_{setupR}	1.0	2.0	—	ns	8 pF	Rx RGMII-ID Figure 48.20
	Data to clock input setup hold @ receiver integrated delay	T_{holdR}	1.0	2.0	—	ns	8 pF	
	Clock cycle duration*1	T_{cyc}	7.2	8	8.8	ns	8 pF	— —
	Duty cycle for gigabit	Duty_G	45	50	55	%	8 pF	
	Duty cycle for 10/100T	Duty_T	40	50	60	%	8 pF	
	Rise/fall time (20-80%)	T_r/T_f	—	—	0.75	ns	8 pF	

Note 1. For 10 Mbps and 100 Mbps, T_{cyc} will scale to 400ns \pm 40ns and 40ns \pm 4ns respectively.

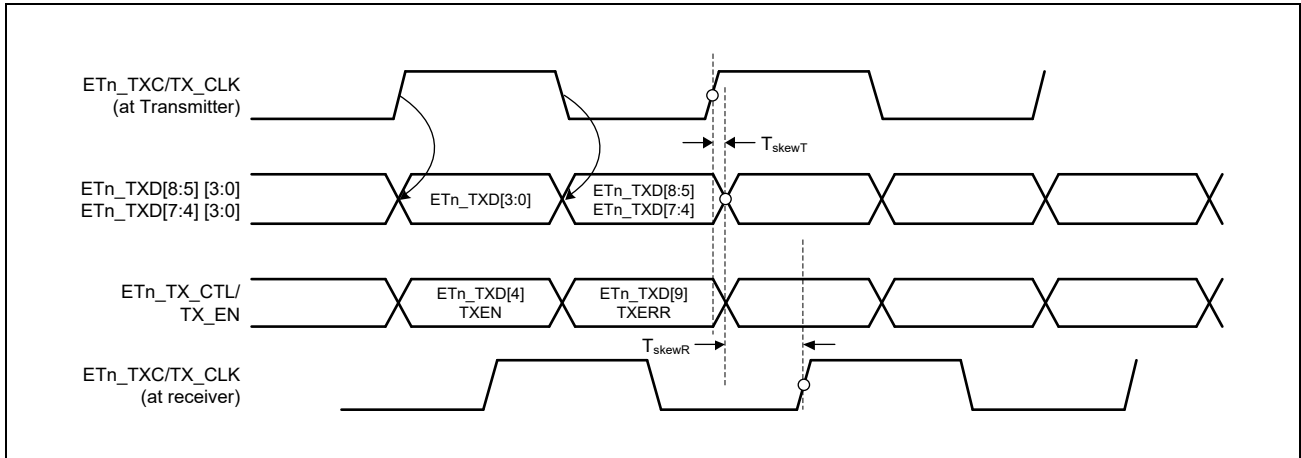

Figure 48.19 Multiplexing & Timing Diagram — RGMII (Transmitter)

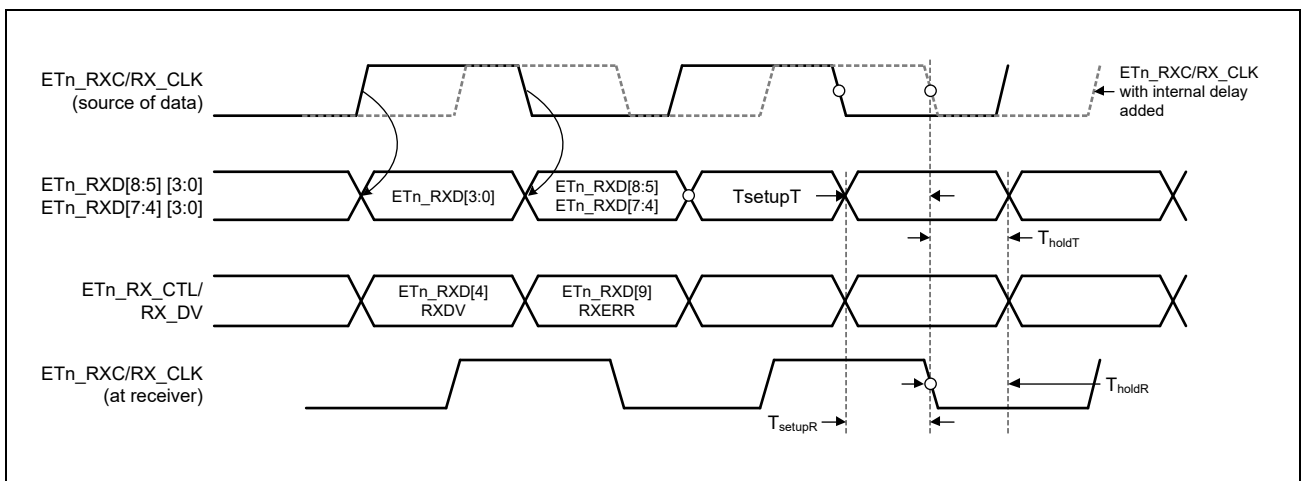

Figure 48.20 Multiplexing & Timing Diagram — RGMII-ID (Receiver)

48.5.6 JTAG Debugger Interface Access Timing

Table 48.33 Debugger IF Timing

Item	Symbol	Min.	Max.	Unit	Figures
TCK_SWCLK cycle time	t_{TCKcyc}	50	—	ns	Figure 48.21
TCK_SWCLK high pulse width	t_{TCKH}	20	—	ns	Figure 48.22
TCK_SWCLK low pulse width	t_{TCKL}	20	—	ns	
TDI setup time	t_{TDIS}	15	—	ns	
TDI hold time	t_{TDIH}	15	—	ns	
TMS_SWDIO setup time	t_{TMSS}	15	—	ns	
TMS_SWDIO hold time	t_{TMSh}	15	—	ns	
SWDIO delay time	t_{SWDO}	—	14	ns	
TDO delay time	t_{TDOD}	—	14	ns	
Capture register setup time	t_{CAPTS}	10	—	ns	Figure 48.23
Capture register hold time	t_{CAPTH}	10	—	ns	
Update register delay time	$t_{UPDATED}$	—	20	ns	

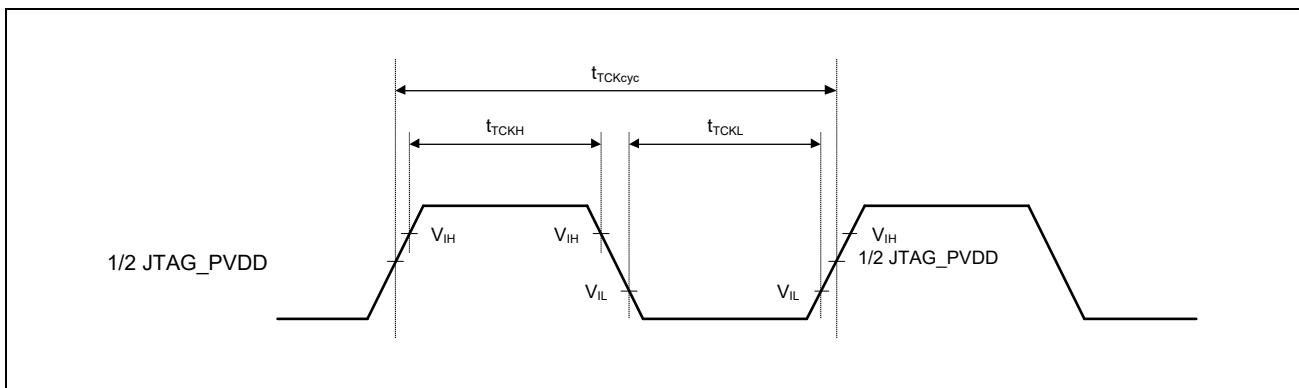

Figure 48.21 TCK_SWCLK Input Timing

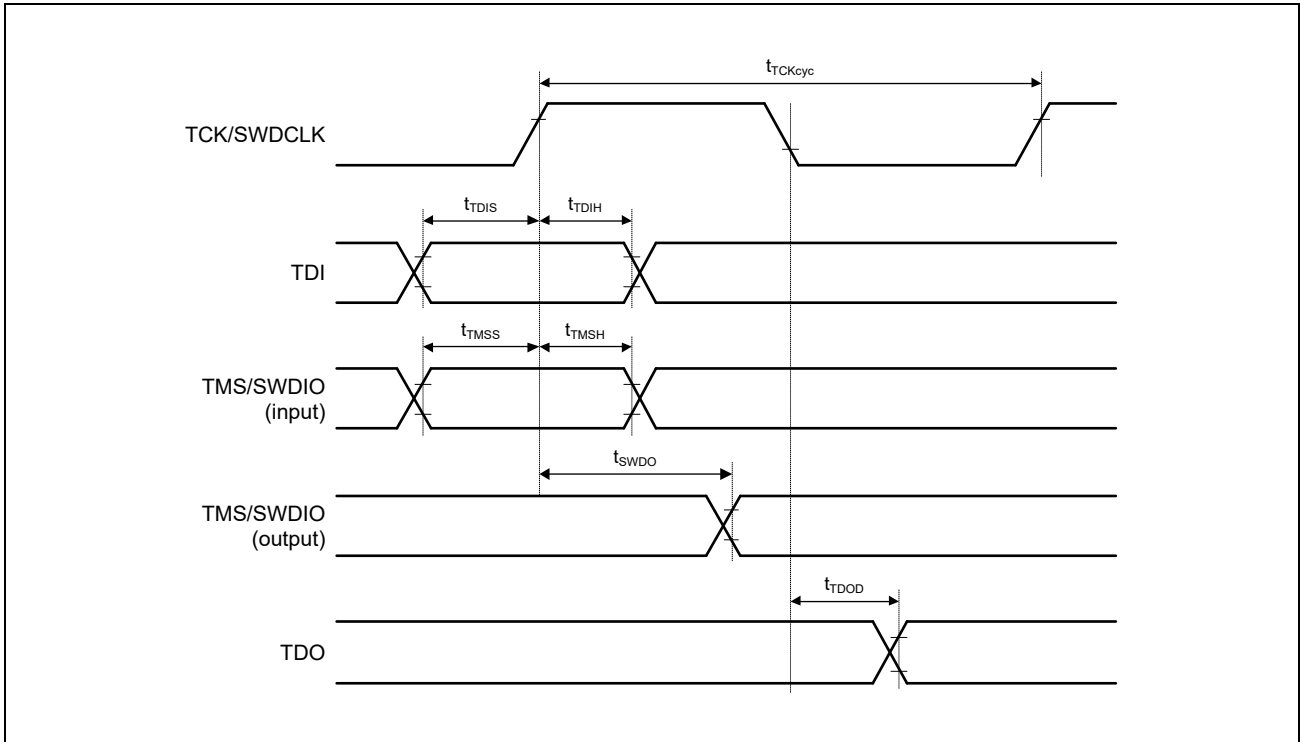

Figure 48.22 Data Transfer Timing

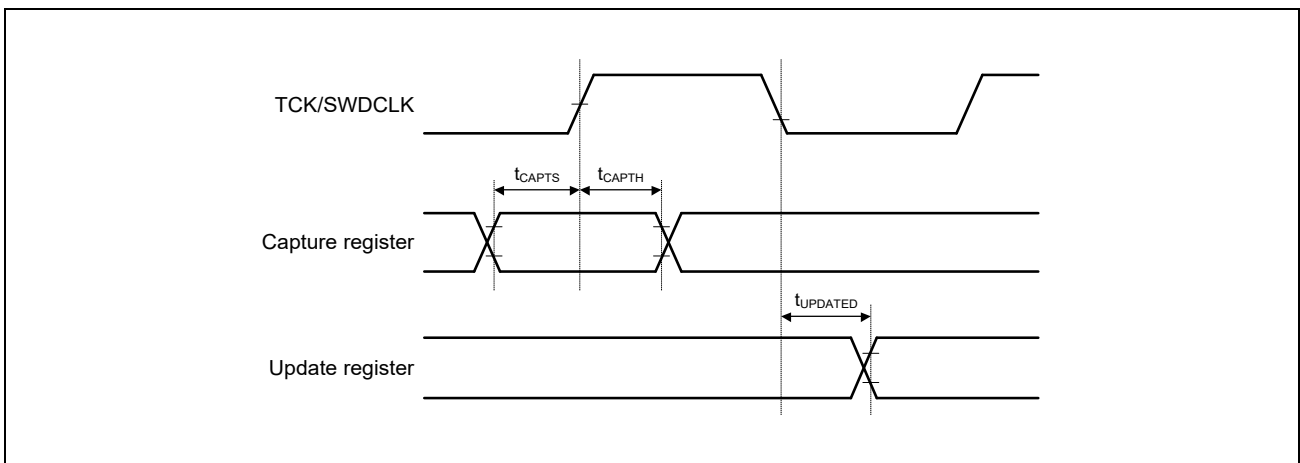

Figure 48.23 Boundary Scan Input/Output I/O Timing

48.5.7 SPI Multi I/O Bus Controller Access Timing

Table 48.34 SPI Multi I/O Bus Controller Access Timing

Item	Symbol	1.8 V		3.3 V		Unit	Figures	
		(Serial flash connected)		(Serial flash connected)				
		Min.	Max.	Min.	Max.			
Clock cycle	t_{SPBcyc}	15.0	—	15.0	—	ns	Figure 48.24	
CLK high pulse width	t_{SPBWH}	0.45	0.55	0.45	0.55	t_{SPBcyc}	Figure 48.24	
CLK low pulse width	t_{SPBWL}	0.45	0.55	0.45	0.55	t_{SPBcyc}	Figure 48.24	
CLK rise time	t_{SPBR}	—	1.0	—	3.2	ns	Figure 48.24	
CLK fall time	t_{SPBF}	—	1.0	—	3.2	ns	Figure 48.24	
Data input setup time	QSPI0_SPCLK base point (SDR mode timing adjusted)	t_{SU}	6.7	—	7.5	—	ns	Figure 48.25
	QSPI0_SPCLK base point (DDR mode timing adjusted)		4.5	—	4.5	—	ns	Figure 48.26
Data input hold time	QSPI0_SPCLK base point (SDR mode timing adjusted)	t_{H}	0.5	—	0.5	—	ns	Figure 48.25
	QSPI0_SPCLK base point (DDR mode timing adjusted)		1.0	—	1.0	—	ns	Figure 48.26
SSL setup time	t_{LEAD}	$1.5 \times t_{SPBcyc} - 3$	$8.5 \times t_{SPBcyc} + 3$	$1.5 \times t_{SPBcyc} - 3$	$8.5 \times t_{SPBcyc} + 3$	ns	Figure 48.25, Figure 48.26	
SSL hold time	t_{LAG}	$1 \times t_{SPBcyc} - 3$	$8 \times t_{SPBcyc} + 3$	$1 \times t_{SPBcyc} - 3$	$8 \times t_{SPBcyc} + 3$	ns	Figure 48.25, Figure 48.26	
Continuous transfer delay time	t_{TD}	$1 \times t_{SPBcyc} - 3$	$8 \times t_{SPBcyc} + 3$	$1 \times t_{SPBcyc} - 3$	$8 \times t_{SPBcyc} + 3$	ns	Figure 48.25, Figure 48.26	
Data output delay time	SDR	t_{OD}	—	2.0	—	5.0	ns	Figure 48.25
	DDR		—	6.5^{*2}	—	7.5^{*3}	ns	Figure 48.26
Data output hold time	SDR	t_{OH}	-2.0	—	-5.0	—	ns	Figure 48.25
	DDR		1.0^{*2}	—	2.1^{*3}	—	ns	Figure 48.26
Data output buffer off time	SDR	t_{BOFF}	—	2.0	—	3.0	ns	Figure 48.27
	DDR		—	2.0	—	3.0	ns	Figure 48.27

Note 1. Output load: 15 pF/driving ability: 12 mA

Note 2. QSPI0_SPCLK frequency: 100 MHz.

Note 3. QSPI0_SPCLK frequency: 66 MHz

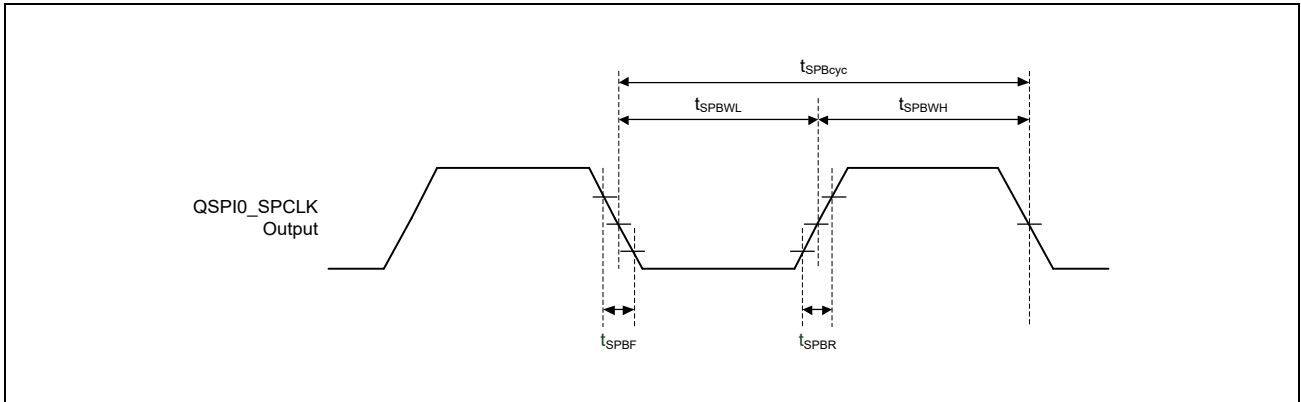

Figure 48.24 Clock Timing

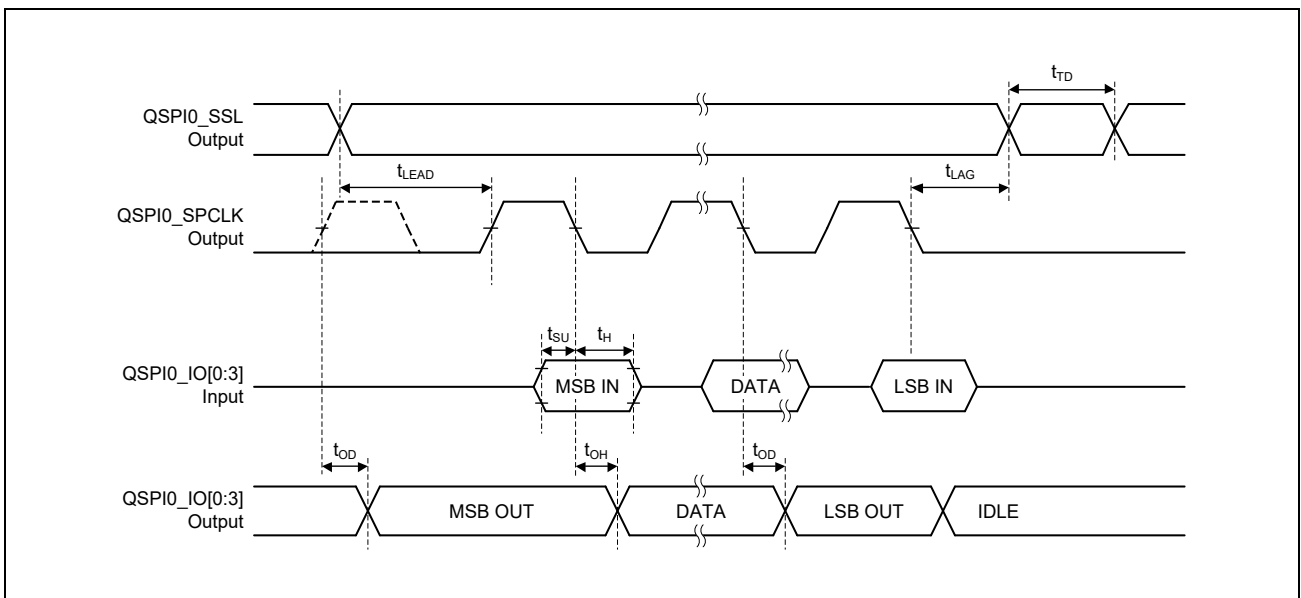

Figure 48.25 SDR Transfer Format Transmission and Reception Timing

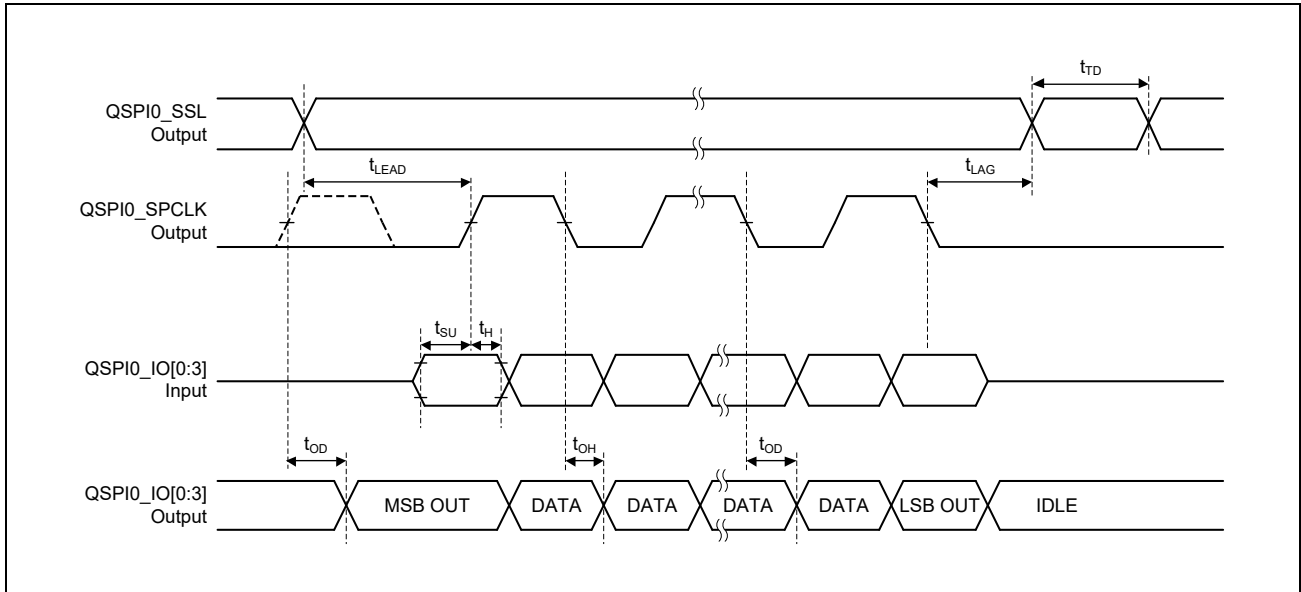

Figure 48.26 DDR Transfer Format Transmission and Reception Timing

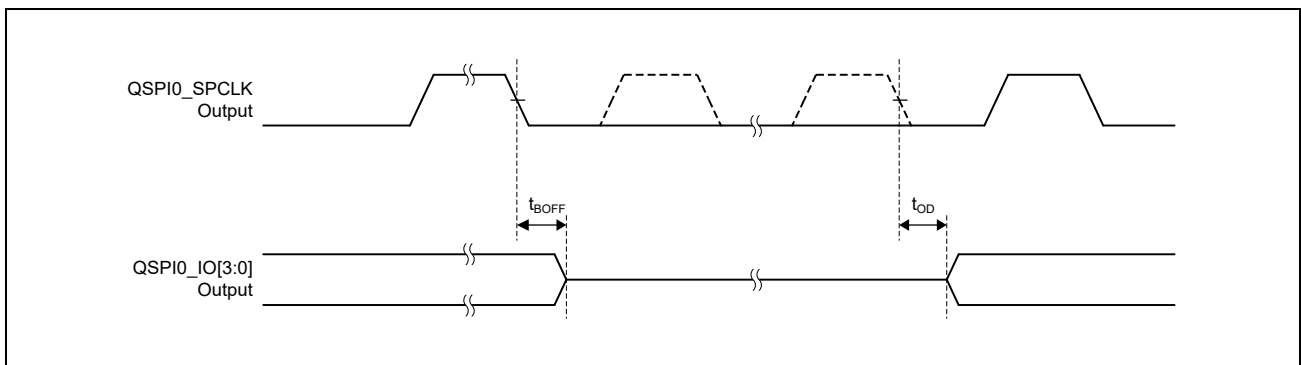

Figure 48.27 Timing for Switching the Buffers On and Off

48.5.8 Control Signal Access Timing

Table 48.35 Control Signal Timing

Item	Symbol	Min.	Max.	Unit	Figures
PRST# pulse width	t_{RESW}	20	—	t_{cyc}^{*1}	Figure 48.28
TRST# pulse width	t_{TRSW}	20	—	t_{cyc}^{*1}	
NMI pulse width	t_{NMIW}	20	—	t_{cyc}^{*1}	Figure 48.30
IRQ pulse width	t_{IRQW}	20	—	t_{cyc}^{*1}	
TINT pulse width	t_{TINTW}	20	—	t_{cyc}^{*1}	
PRST# input rise time	t_{RSr}	—	500	μs	Figure 48.29

Note 1. $t_{cyc} = 41.666 \text{ ns}$ (24 MHz)

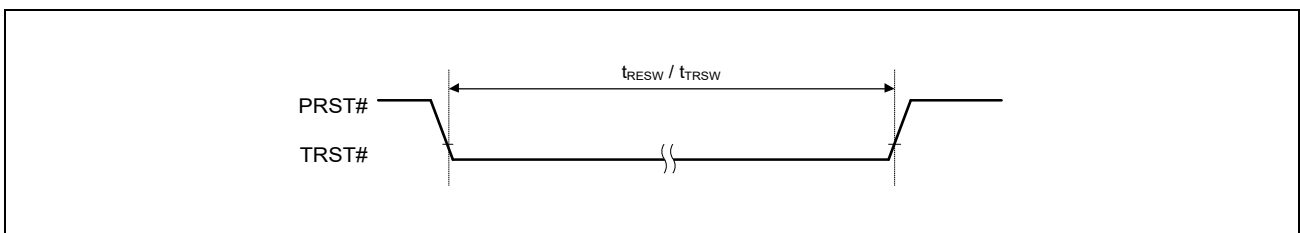

Figure 48.28 Reset Input Timing 1

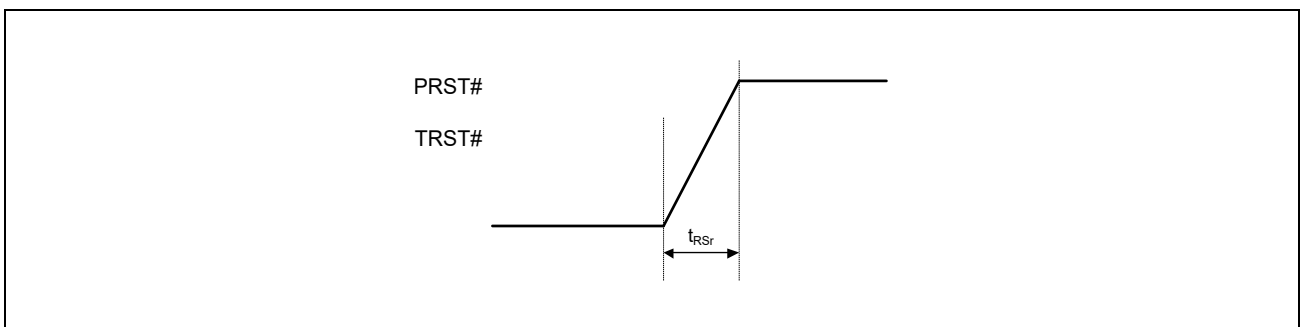

Figure 48.29 Reset Input Timing 2

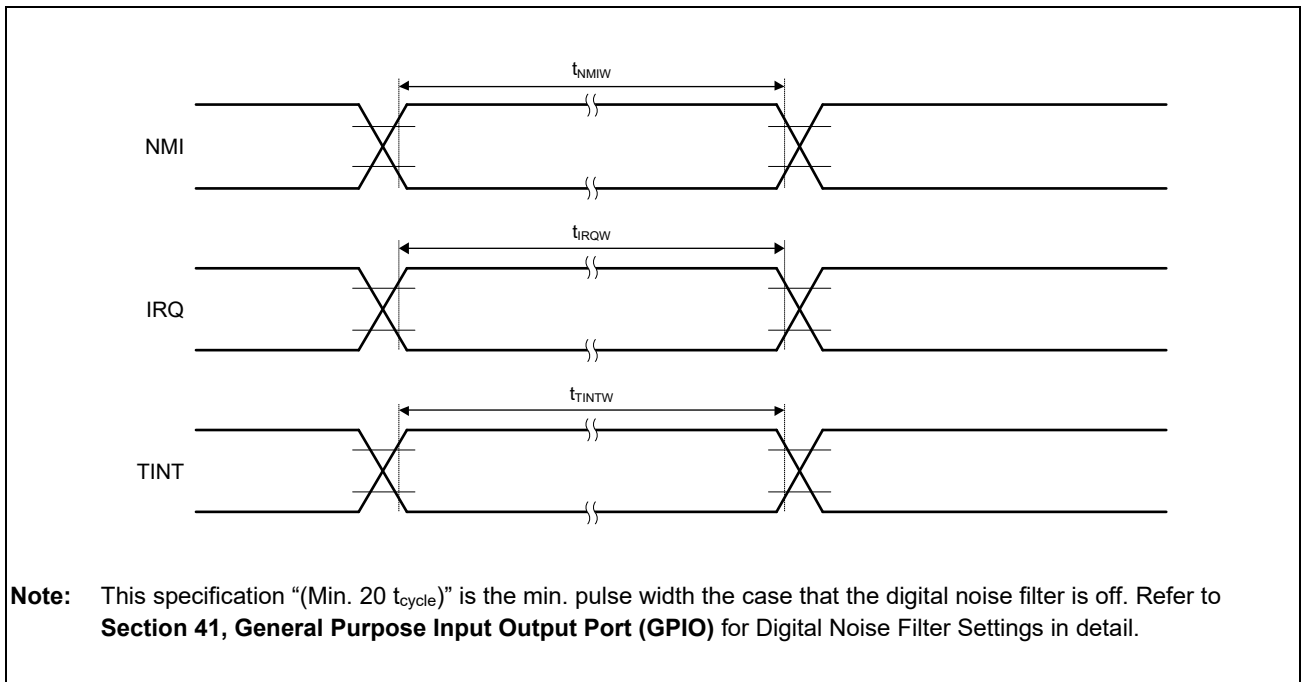

Figure 48.30 Interrupt Signal Input Timing

48.5.9 Serial Sound Interface (SSIF-2) Access Timing

Table 48.36 SSIF-2 Timing

Item	I/O	Symbol	Min.	Max.	Unit	Figures
Output clock cycle	Output	t_O	80	64000	ns	Figure 48.31
Input clock cycle	Input	t_I	80	—	ns	
Clock high	Bidirectional	t_{HC}	32	—	ns	
Clock low		t_{LC}	32	—	ns	
Clock rise time/clock fall time	Output	t_{RC}/t_{FC}	—	25	ns	
Setup time	Input	t_{SR}	25	—	ns	Figure 48.32,
Hold time		t_{HR}	5	—	ns	Figure 48.33,
SILRCK output delay time	Output	t_{DTR}	-5	25	ns	Figure 48.34
Data output delay time (Noise canceler not in use)		t_{DTR}	-5	25	ns	
Data output delay time (Noise canceler in use)		t_{DTR}	10	50	ns	

Note: AC access timing condition: drive ability 12mA, output load 30pF, slew rate = fast

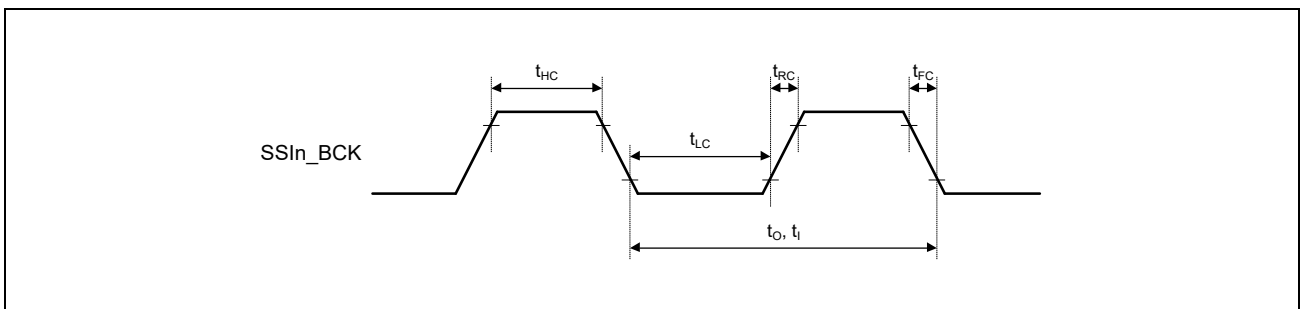

Figure 48.31 Bit Clock Input/Output Timing

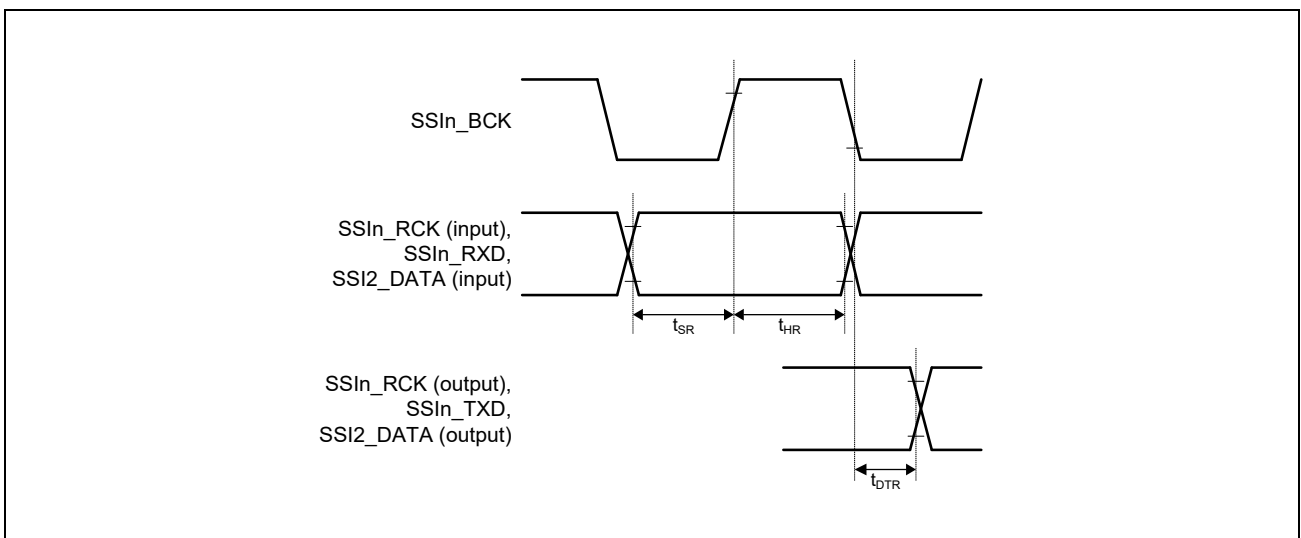

Figure 48.32 Transmission and Reception Timing (SSIBCK Falling Output)

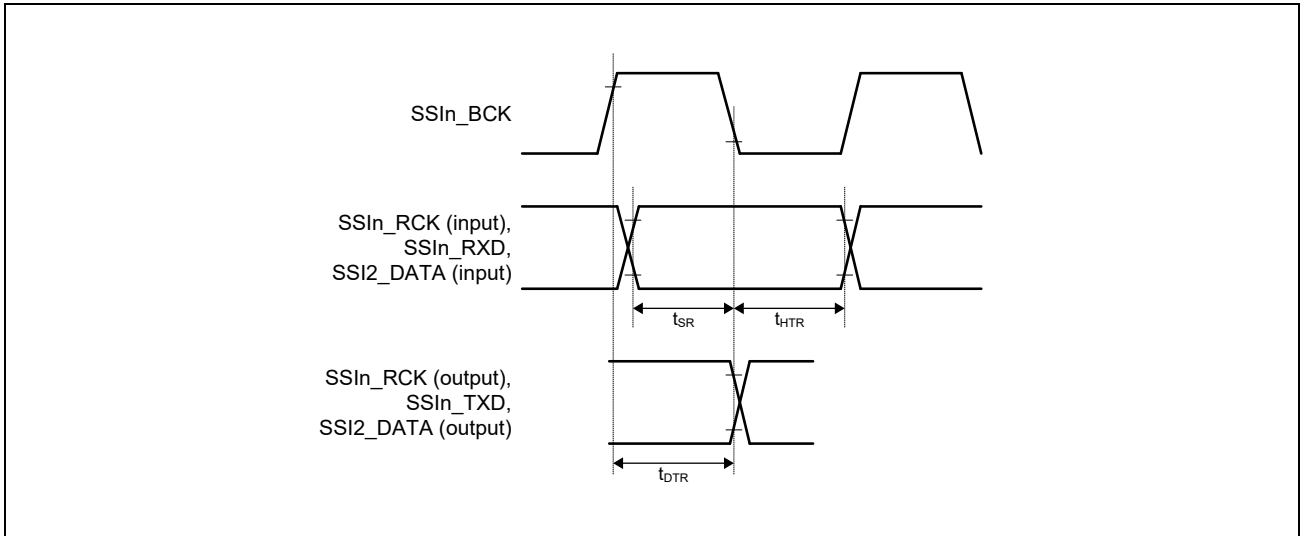

Figure 48.33 Transmission and Reception Timing (SSIBCK Rising Output)

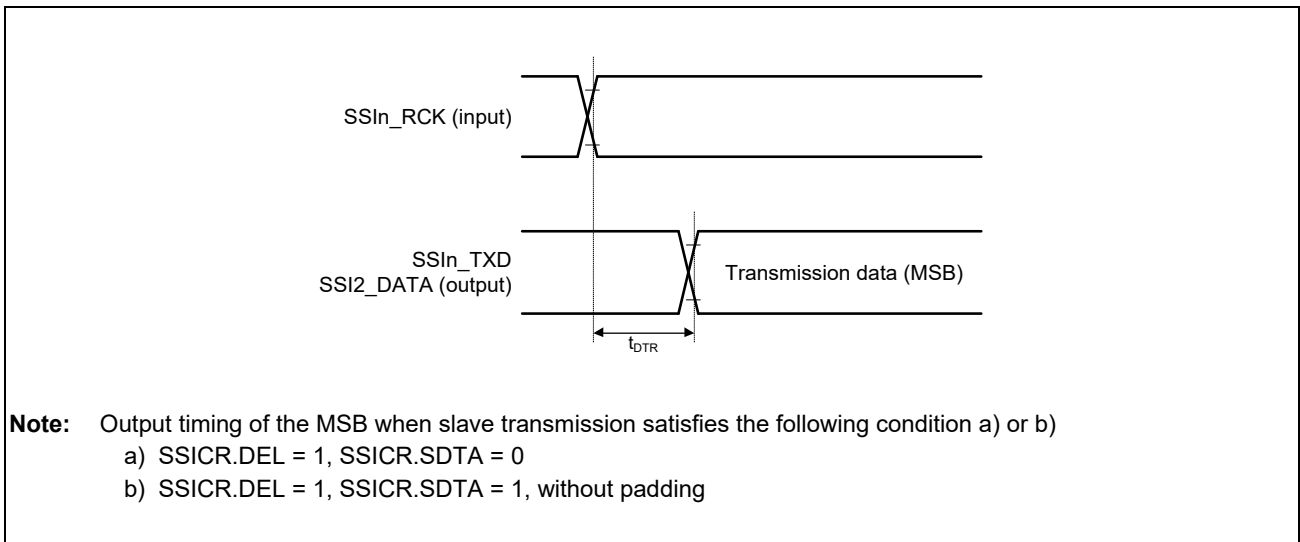

Figure 48.34 Transmission Timing (Slave, in Synchronization with SSILRCK)

48.5.10 CAN-FD Interface Access Timing

Table 48.37 CAN-FD Interface Timing

Item	Symbol	CAN		CAN-FD		Unit	Figures
		Min.	Max.	Min.	Max.		
Internal delay time	t_{node}^{*1}	—	100	—	75	ns	Figure 48.35
Transmission rate	—	—	1	—	4	Mbps	

Note: AC access timing condition: drive ability 12mA, output load 15pF, slew rate = fast

Note 1. Internal delay time (t_{node}) = Internal transfer delay time (t_{output}) + Internal receive delay time (t_{input})

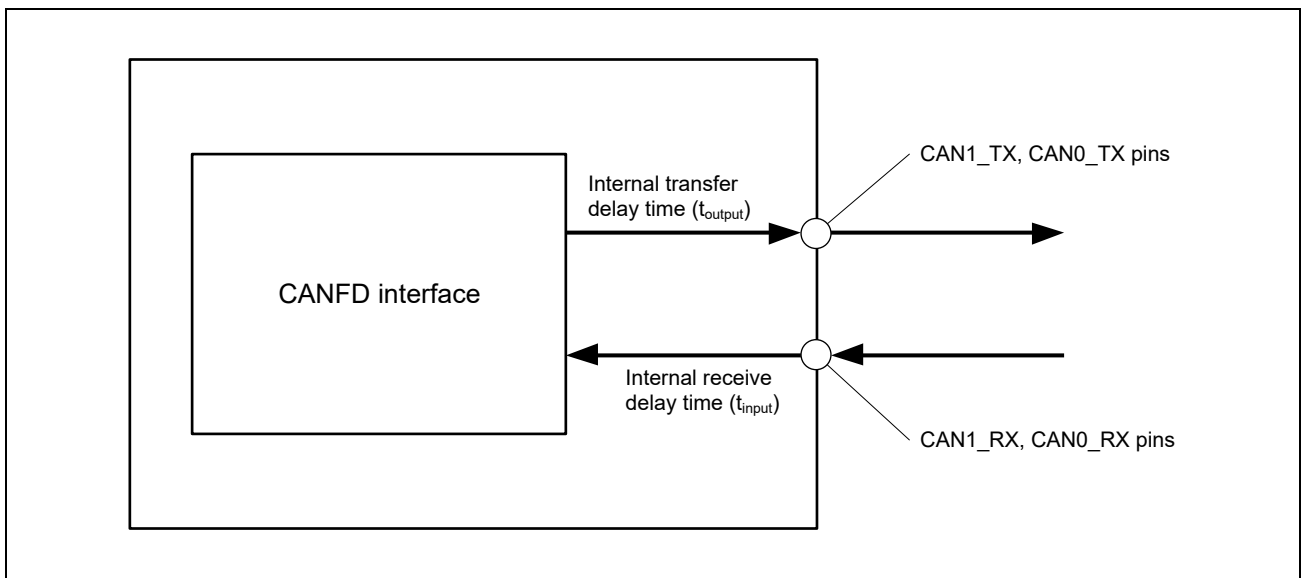

Figure 48.35 CAN-FD Interface Condition

48.5.11 Multi-Function Timer Pulse Unit 3 (MTU3a) Access Timing

Table 48.38 MTU3a Timing

Item		Symbol	Min.	Max.	Unit*1	Figures
MTU3a	Input capture input pulse width	Single-edge setting	1.5	—	t_{p1cyc}^{*1}	Figure 48.36
		Both-edge setting	2.5	—		
MTU3a	Timer clock pulse width	Single-edge setting	1.5	—	t_{p1cyc}^{*1}	Figure 48.37
		Both-edge setting	2.5	—		
		Phase counting mode	2.5	—		

Note: AC access timing condition: drive ability 4mA, output load 30pF, slew rate = fast

Note 1. t_{p1cyc} indicates peripheral clock means MTU_X_MCLK_MTU3 (P0φ).

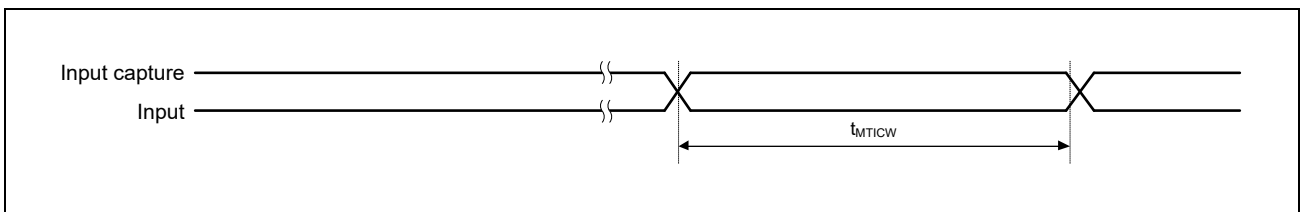

Figure 48.36 MTU3a Input Capture Input Timing

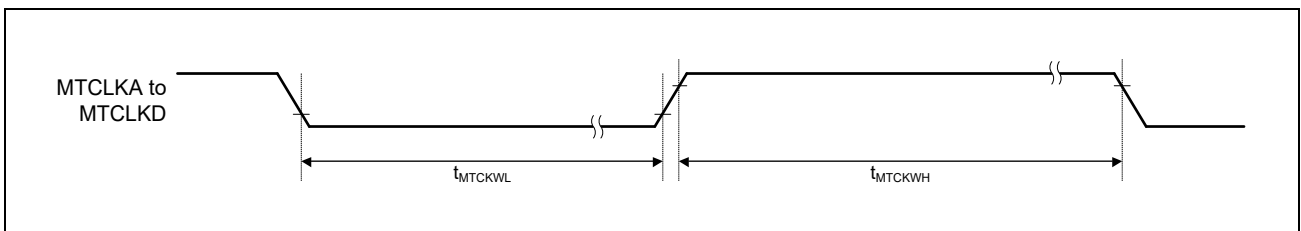

Figure 48.37 MTU3a Clock Input Timing

48.5.12 Port Output Enable 3 (POE3) Access Timing

Table 48.39 POE3 Timing

Item	Symbol	Min.	Max.	Unit	Figures
POE3	POEn# input pulse width	t_{POE3W}	1.5	—	t_{p1cy}^{*1} Figure 48.38

Note 1. t_{p1cy} indicates peripheral clock means POE3_CLKM_POE (P0 ϕ).

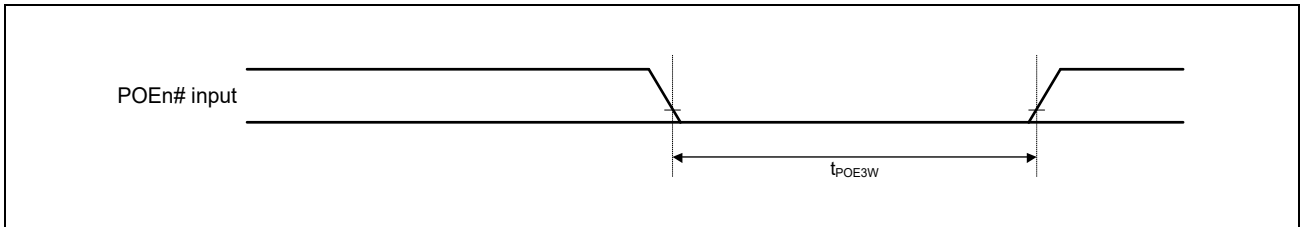

Figure 48.38 POEn# Input Pulse Timing

48.5.13 I²C Bus Interface Access Timing

Table 48.40 I²C Bus Interface Timing

Item	Symbol	I/O	Standard Mode (Sm)		Fast Mode (Fm)		Fast Mode Plus (Fm+)		Unit
			Min.	Max.	Min.	Max.	Min.	Max.	
SCL clock frequency	f _{CLK}	I/O	0	100	0	400	0	1000	kHz
Bus free time (between stop and start condition)	t _{BUF}	I/O	4.7	—	1.3	—	0.5	—	μs
Hold time*1	t _{HD:STA}	I/O	4.0	—	0.6	—	0.26	—	μs
Low period of SCL clock	t _{LOW}	I/O	4.7	—	1.3	—	0.5	—	μs
High period of SCL clock	t _{HIGH}	I/O	4.0	—	0.6	—	0.26	—	μs
Setup time for start / restart condition	t _{SU:STA}	I/O	4.7	—	0.6	—	0.26	—	μs
Data hold time (I ² C bus device)	t _{HD:DAT}	I/O	0*2	—	0*2	—	0	—	μs
Data setup time	t _{SU:DAT}	I/O	250	—	100*3	—	50	—	ns
SDA and SCL signal rise time	t _R	Input	—	1000	20	300	—	120	ns
SDA and SCL signal fall time*3	t _F	Input	—	300	20 × (P _{VDD} /5.5 V)	300	20 × (P _{VDD} /5.5 V)	120	ns
		Output	—	300	20 × (P _{VDD} /5.5 V)*6	300*6	20 × (P _{VDD} /5.5 V)*7	120*7	ns
Setup time for STOP condition	t _{SU:STO}	I/O	4.0	—	0.6	—	0.26	—	μs
Capacitive load for each bus line	C _b	—	—	400*4	—	400*4	—	550*4	pF
Pulse width of spikes that must be suppressed by the input filter	t _{SP}	Input	—	—	0	50*5	0	50*5	ns

Note: In the above table and subsequently, SCL and SDA refer to the RIICnSCL and RIICnSDA signals, respectively.

Note: AC access timing condition: drive ability 4mA, output load 400pF, slew rate = slow

- Note 1. The first clock pulse is generated on the SCL line after the start condition has been issued and the hold time has elapsed.
- Note 2. This module requires a minimum of 300 ns hold time internally for the SDA signal to handle the period over which the falling edge of SCL has not reached a defined level (time until the CnSCL signal reaches V_{IL} (max.) from V_{IH} (min.)).
- Note 3. The fast-mode I²C bus device can be used in the standard mode I²C bus system. In this case, the minimum value of the data setup time (t_{SU:DAT} (min.) 250 [ns]) must be satisfied.
If the system does not extend the low period of SCL clock (t_{LOW}), this condition is automatically satisfied. If the system extends the low period of SCL clock (t_{LOW}), transmit the subsequent data bit to the SDA line before the SCL line is released (t_R (max.) + t_{SU:DAT} (min.) = 1000 + 250 = 1250 [ns]: (standard mode I²C bus specification)).
- Note 4. Total capacitance of one bus line. The allowable maximum bus capacitance may differ from this specification, depending on the actual operating voltage and frequency of an application. For techniques to cope with a large bus capacitance, see the I²C bus specification provided by NXP Semiconductors.
- Note 5. Noise is removed by the analog and digital input filters. The level of noise reduction of the digital input filter is determined by the period of internal reference clock (IICφ) and the NF[1:0] bits in RIICnMR3. For details, refer to **Section 26, I²C Bus Interface**.
- Note 6. External pull-up resistor is required 1077Ω to 1770Ω when using RIIC ch2 or RIIC ch3.
- Note 7. External pull-up resistor is required 240Ω to 257Ω when using RIIC ch2 or RIIC ch3.

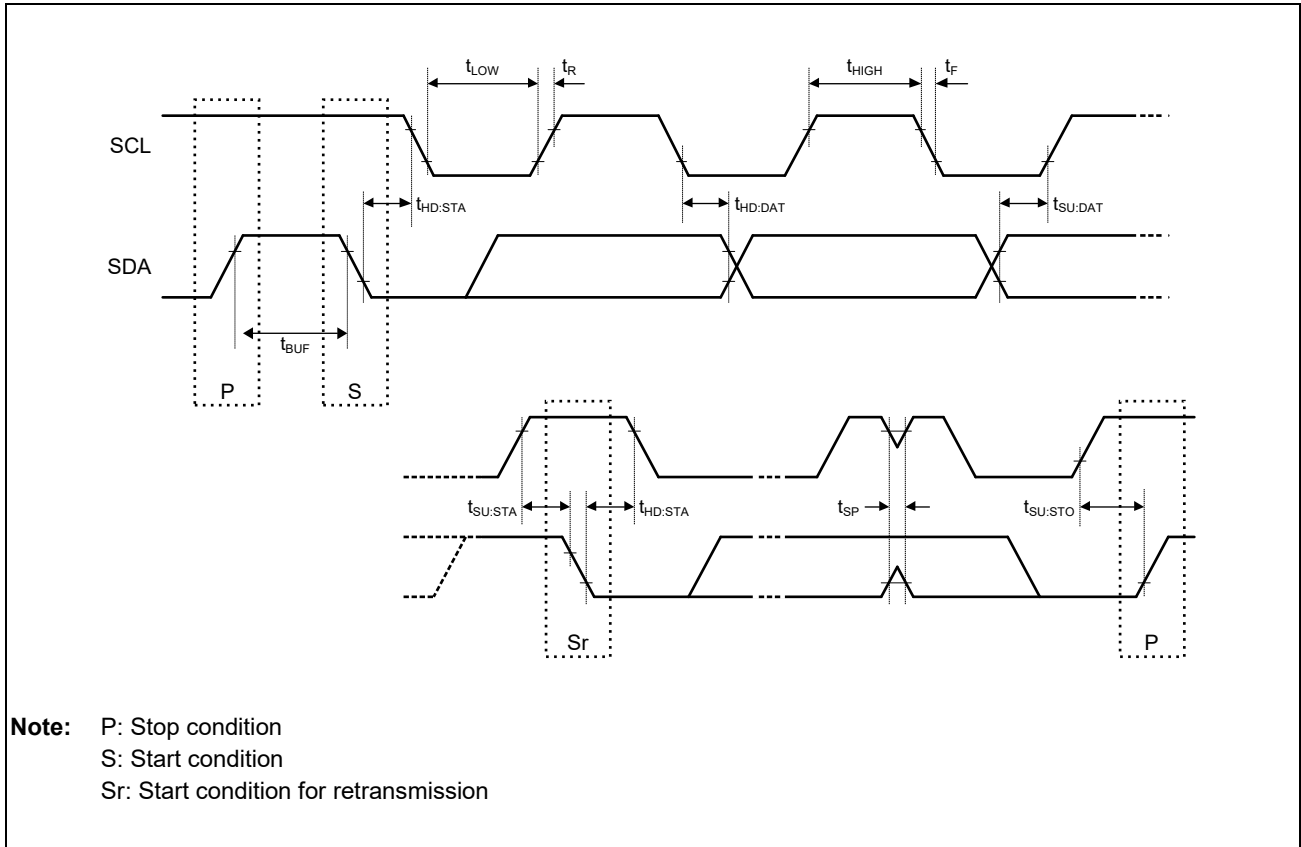

Figure 48.39 Input/Output Timing

48.5.14 Serial Communications Interface with FIFO (SCIFA) Access Timing

Table 48.41 SCIFA Timing

Item		Symbol	Min.	Max.	Unit	Figures	
SCIFA	Input clock cycle	Asynchronous	t_{Syc}	4	—	t_{p1cyc}^{*1}	Figure 48.40
		Clocked synchronous		12	—		
	Input clock pulse width		t_{SCKW}	0.4	0.6	t_{p1cyc}^{*1}	
	Input clock rise time		t_{SCKr}	—	5	ns	
	Input clock fall time		t_{SCKf}	—	5	ns	
	Output clock cycle	Asynchronous*2	t_{Syc}	8	—	t_{p1cyc}^{*1}	
		Clocked synchronous		4	—		
	Output clock pulse width		t_{SCKW}	0.4	0.6	t_{p1cyc}^{*1}	
	Output clock rise time		t_{SCKr}	—	9	ns	
	Output clock fall time		t_{SCKf}	—	9	ns	
Transmit data delay time	Internal clock	t_{TXD}	-10	10	ns	Figure 48.41	
	External clock		$3 \times t_{p1cyc}^{*1}$	$4 \times t_{p1cyc}^{*1} + 20$			
Receive data setup time	Internal clock	t_{RXS}	$3 \times t_{p1cyc}^{*1} + 20$	—	ns		
	External clock		$t_{p1cyc}^{*1} + 10$	—			
Receive data hold time	Internal clock	t_{RXH}	$-3 \times t_{p1cyc}^{*1}$	—	ns		
	External clock		$2 \times t_{p1cyc}^{*1} + 10$	—			

Note: AC access timing condition: drive ability 12mA, output load 30pF, slew rate = fast

Note 1. t_{p1cyc} indicates peripheral clock means SCIFn_CLK_PCK (P0φ) (n = 0 to 4).

Note 2. When the SEMR.ABCS0 and SEMR.BGDM bits are set to 1.

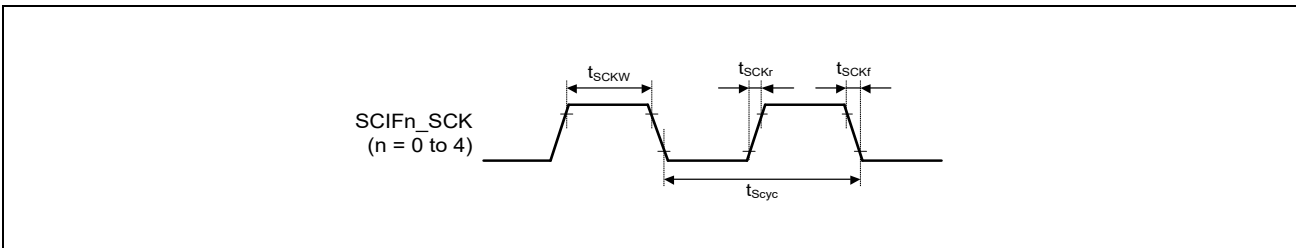

Figure 48.40 SCK Input Clock Timing

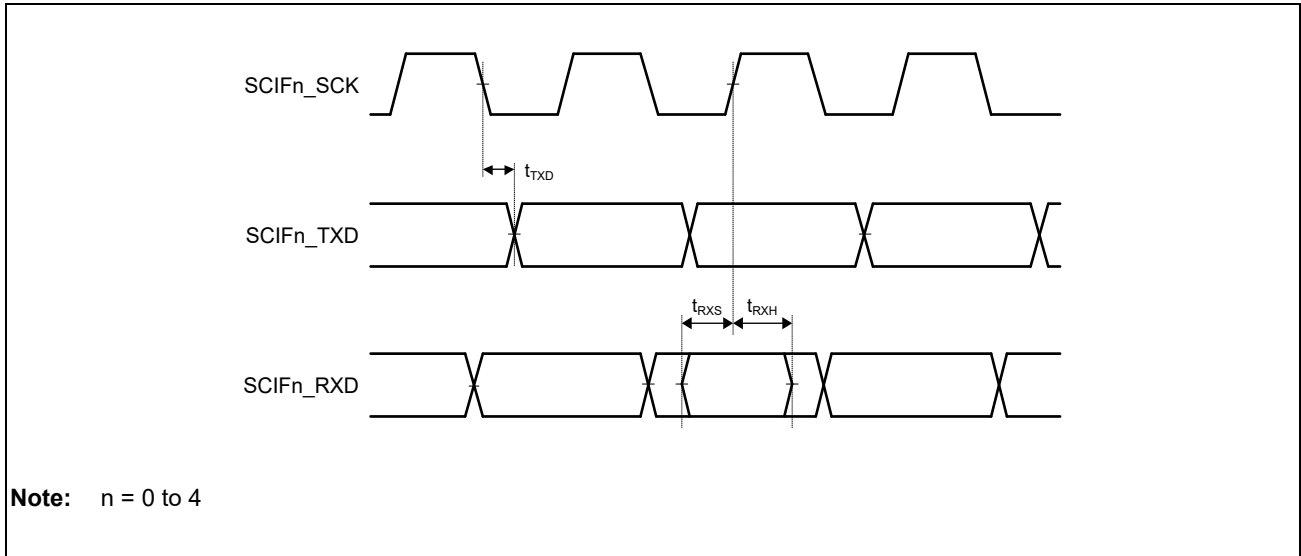

Figure 48.41 SCIFA Input/Output Timing in Clocked Synchronous Mode

48.5.15 Serial Communications Interface (SClG) Access Timing

Table 48.42 SClG Timing

Item		Symbol	Min.	Max.	Unit	Figures	
SClG	Input clock cycle	Asynchronous	$t_{S_{cyc}}$	4	—	t_{p1cyc}^{*1}	Figure 48.42
		Clocked synchronous		6	—		
	Input clock pulse width		$t_{S_{CKW}}$	0.4	0.6	t_{p1cyc}^{*1}	
	Input clock rise time		$t_{S_{CKr}}$	—	5	ns	
	Input clock fall time		$t_{S_{CKf}}$	—	5	ns	
	Output clock cycle	Asynchronous*2	$t_{S_{cyc}}$	8	—	t_{p1cyc}^{*1}	
		Clocked synchronous		4	—		
	Output clock pulse width		$t_{S_{CKW}}$	0.4	0.6	t_{p1cyc}^{*1}	
	Output clock rise time		$t_{S_{CKr}}$	—	5	ns	
	Output clock fall time		$t_{S_{CKf}}$	—	5	ns	
Transmit data delay time	Clocked synchronous	t_{TXD}	—	28	ns	Figure 48.43	
Receive data setup time	Clocked synchronous	t_{RXS}	15	—	ns		
Receive data hold time	Clocked synchronous	t_{RXH}	5	—	ns		

Note: AC access timing condition: drive ability 12mA, output load 30pF, slew rate = fast

Note 1. t_{p1cyc} indicates peripheral clock means SCl_n_CLKP (P0φ) (n = 0 to 1).

Note 2. When the SEMR.ABCS0 and SEMR.BGDM bits are set to 1.

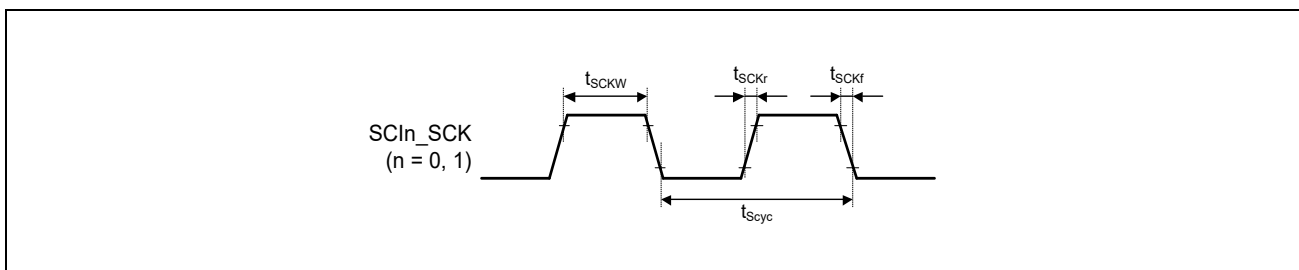

Figure 48.42 SCK Input Clock Timing

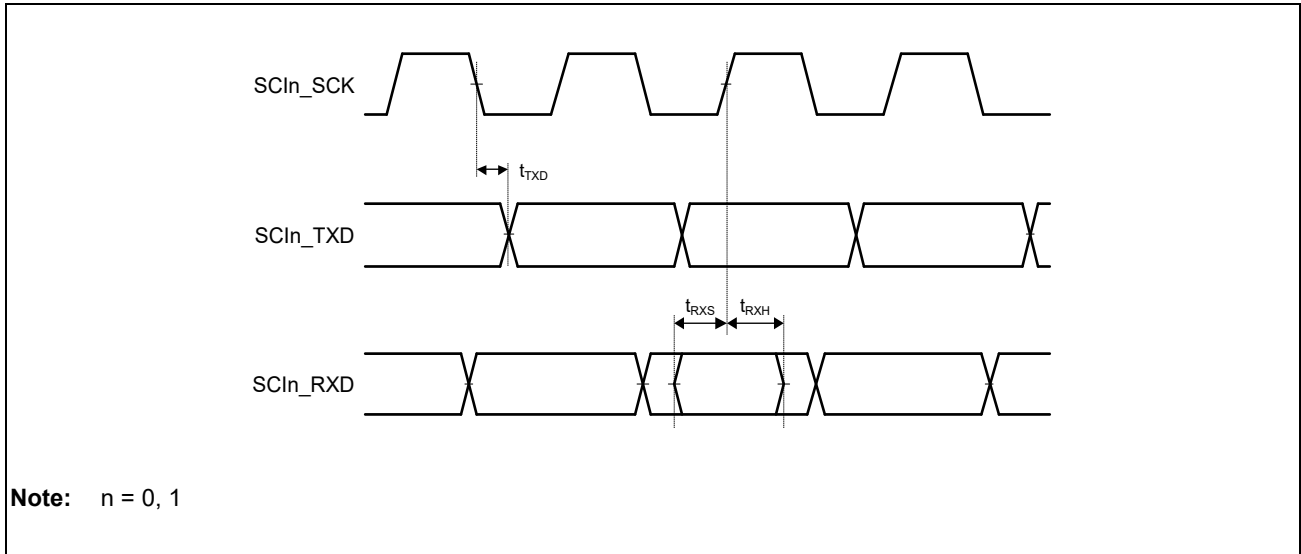

Figure 48.43 SCIFA Input/Output Timing in Clocked Synchronous Mode

48.5.16 Renesas Serial Peripheral Interface (RSPI) Access Timing

Table 48.43 Renesas Serial Peripheral Interface Timing

Item		Symbol	Min.	Max.	Unit	Figure
RSPCK clock cycle	Master	t_{SPcyc}	2	4096	t_{p1cyc}^{*1}	Figure 48.44 Figure 48.45 to Figure 48.48 Figure 48.47, Figure 48.48
	Slave		8	4096		
RSPCK clock high pulse width	Master	t_{SPCKWH}	0.4	—	t_{SPcyc}^{*1}	
	Slave		0.4	—		
RSPCK clock low pulse width	Master	t_{SPCKWL}	0.4	—	t_{SPcyc}^{*1}	
	Slave		0.4	—		
Data input setup time	Master	t_{SU}	10	—	ns	
	Slave		0	—	t_{p1cyc}^{*1}	
Data input hold time	Master	t_H	0	—	ns	
	Slave		4	—	t_{p1cyc}^{*1}	
SSL setup time	Master	t_{LEAD}	$1 \times t_{SPcyc} - 20$	$8 \times t_{SPcyc}$	ns	
	Slave		4	—	t_{p1cyc}^{*1}	
SSL hold time	Master	t_{LAG}	$1 \times t_{SPcyc}$	$8 \times t_{SPcyc} + 20$	ns	
	Slave		4	—	t_{p1cyc}^{*1}	
Data output delay time	Master	t_{OD}	—	19	ns	
	Slave		—	4	t_{p1cyc}^{*1}	
Data output hold time	Master	t_{OH}	5	—	ns	
	Slave		2	—	t_{p1cyc}^{*1}	
Continuous transmission delay time	Master	t_{TD}	$1 \times t_{SPcyc} + 2 \times t_{cyc}$	$8 \times t_{SPcyc} + 2 \times t_{cyc}$	ns	
	Slave		$4 \times t_{cyc}$	—		
Slave access time		t_{SA}	—	4	t_{p1cyc}^{*1}	
Slave out release time		t_{REL}	—	3	t_{p1cyc}^{*1}	

Note: AC access timing condition: drive ability 12mA, output load 30pF, slew rate = fast

Note 1. t_{p1cyc} indicates peripheral clock means RSPIn_CLKB (P0φ) (0 to 2).

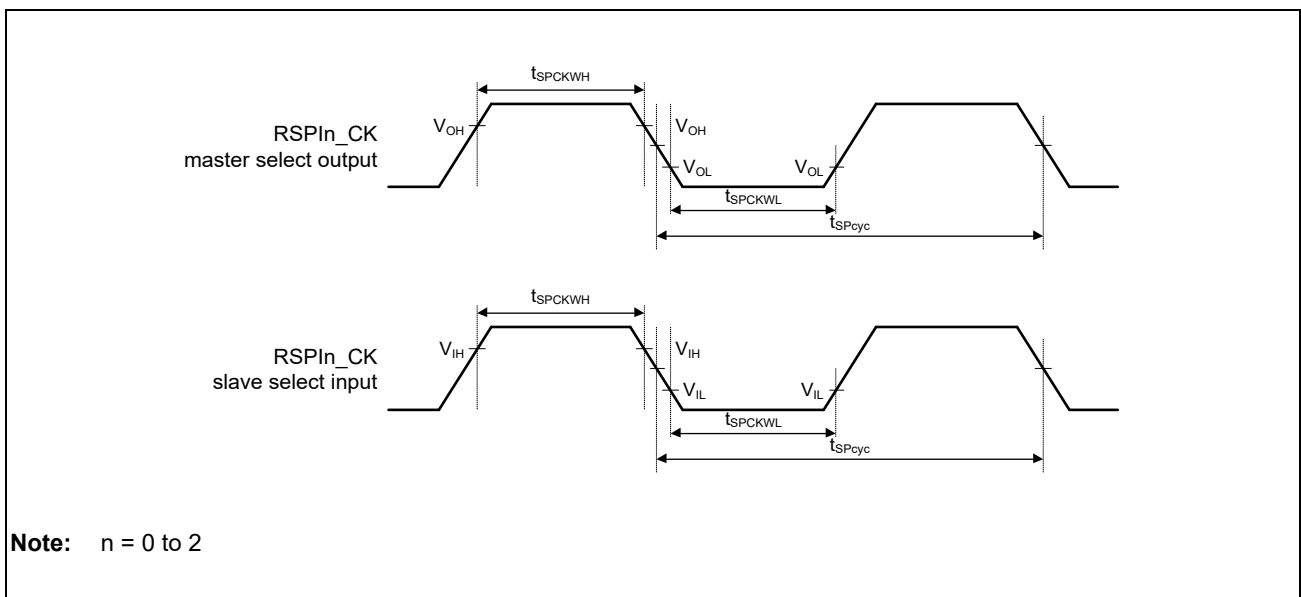

Figure 48.44 Clock Timing

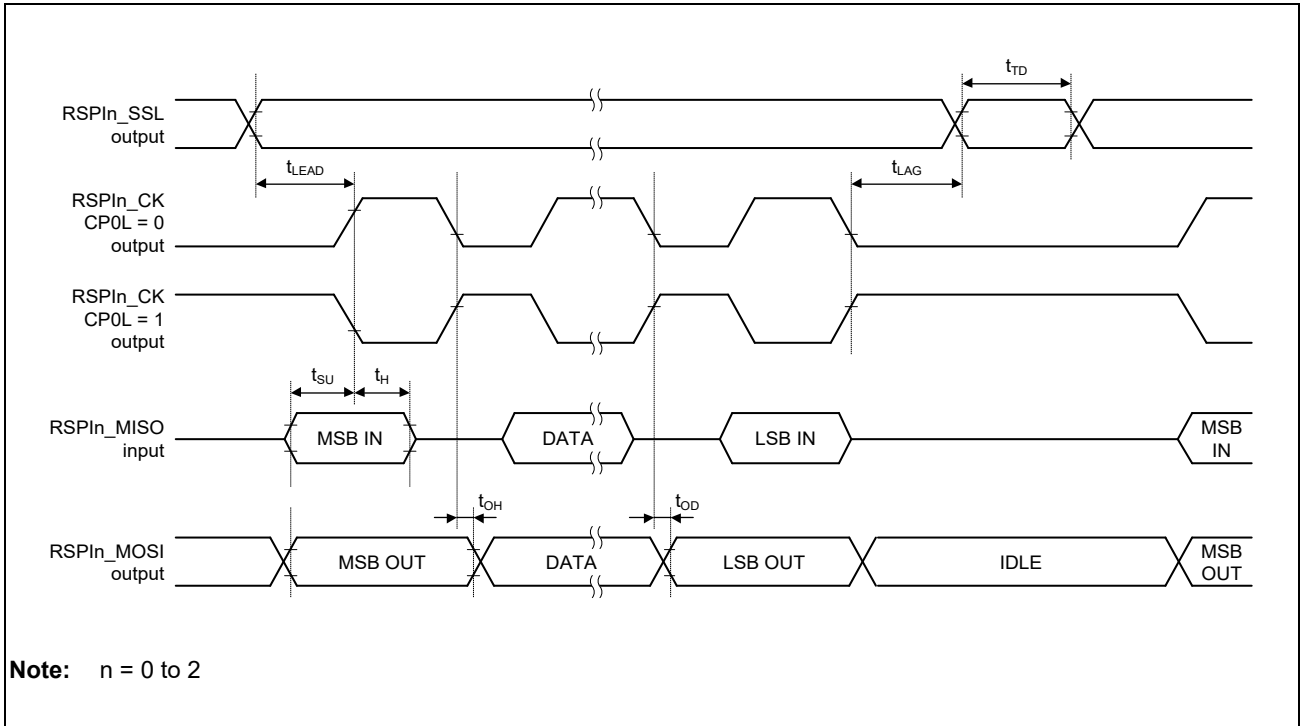

Figure 48.45 Transmission and Reception Timing (Master, CPHA = 0)

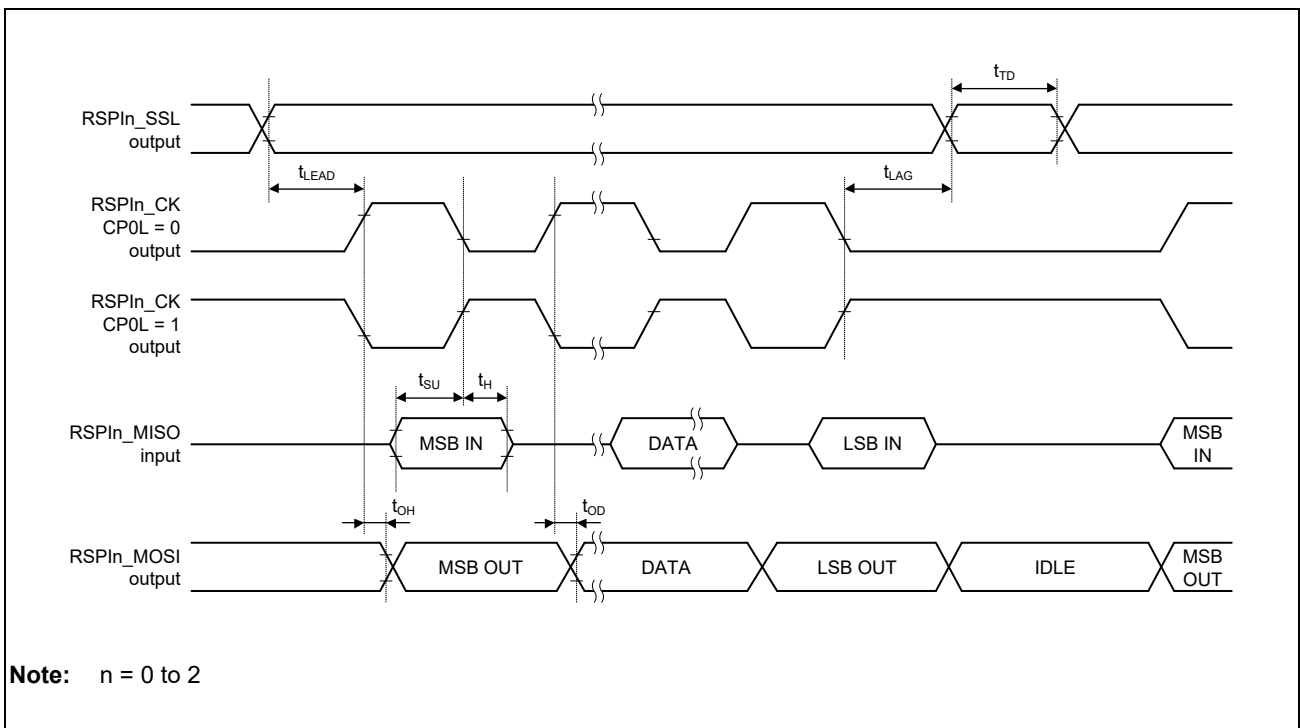

Figure 48.46 Transmission and Reception Timing (Master, CPHA = 1)

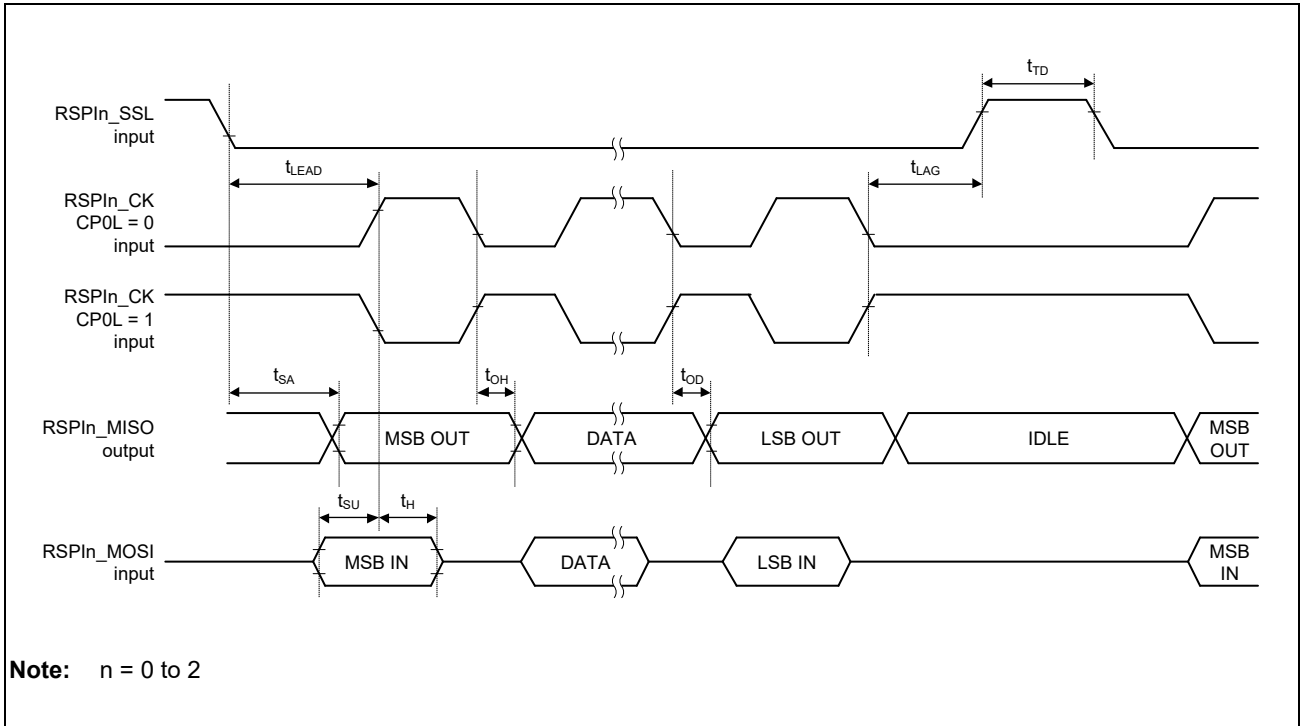

Figure 48.47 Transmission and Reception Timing (Slave, CPHA = 0)

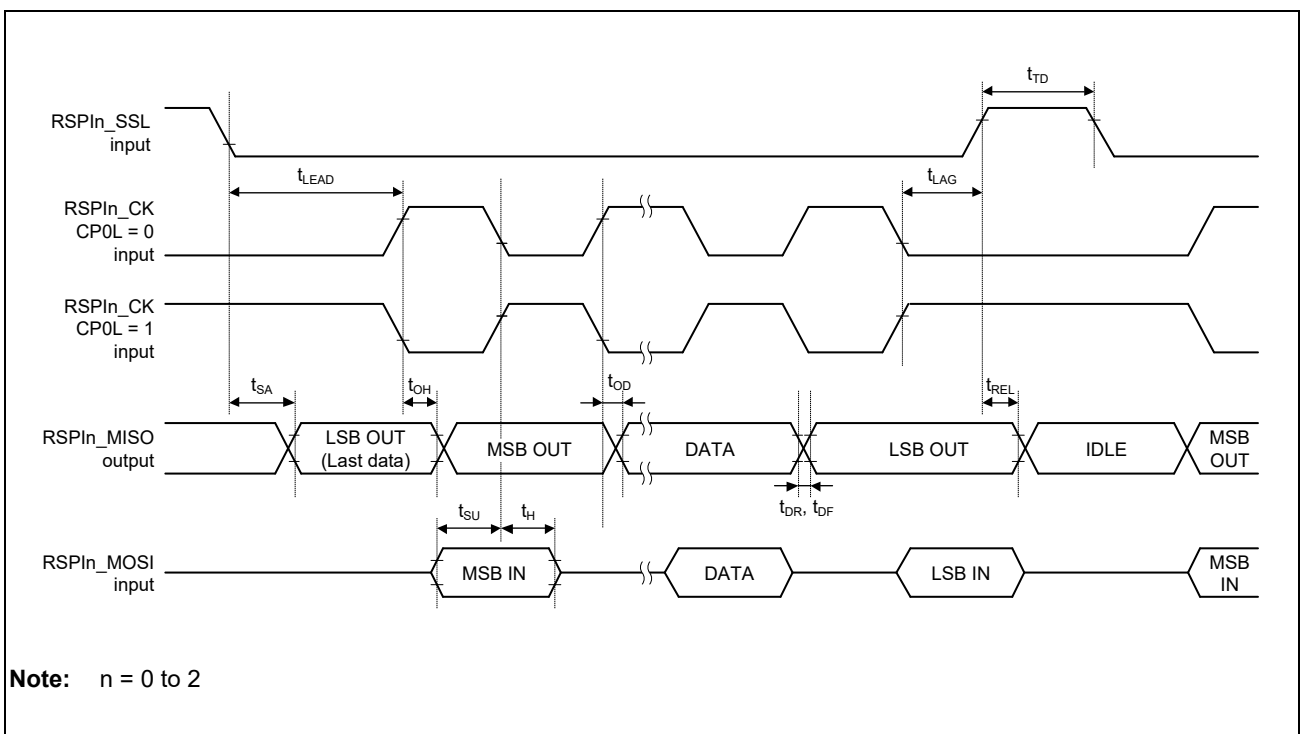

Figure 48.48 Transmission and Reception Timing (Slave, CPHA = 1)

48.5.17 A/D Converter Access Timing

Table 48.44 A/D Converter Timing

Item	Symbol	Min.	Max.	Unit	Figures
ADC Trigger Input Pulse Width	t_{TRGW}	1.5*2		t_{P1cyc}^{*1}	Figure 48.49

Note 1. t_{P1cyc} indicates peripheral clock means ADC_ADCLK (TSU ϕ).

Note 2. When a noise filter in ADC is off.

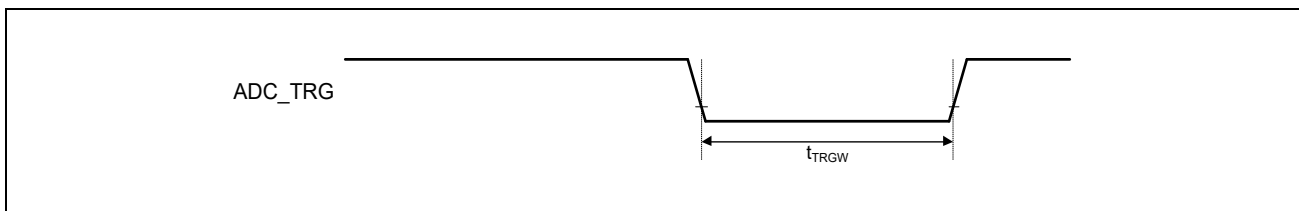

Figure 48.49 ADC Trigger Input Timing

48.5.18 Watchdog Timer Access Timing

Table 48.45 Watchdog Timer Timing

Item	Symbol	Min.	Max.	Unit	Figures
WDTOVF_PERROUT# Output Time	t_L	64	64	t_{P1cyc}^{*1}	Figure 48.50

Note 1. t_{P1cyc} indicates peripheral clock means WDTn_CLK (OSCCLK) (n = 0, 2).

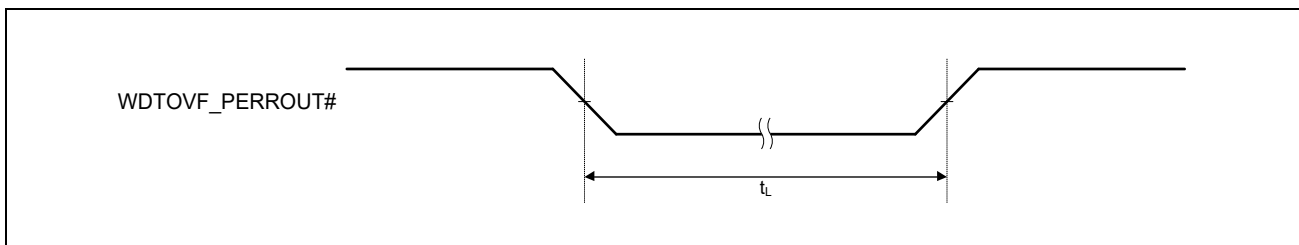
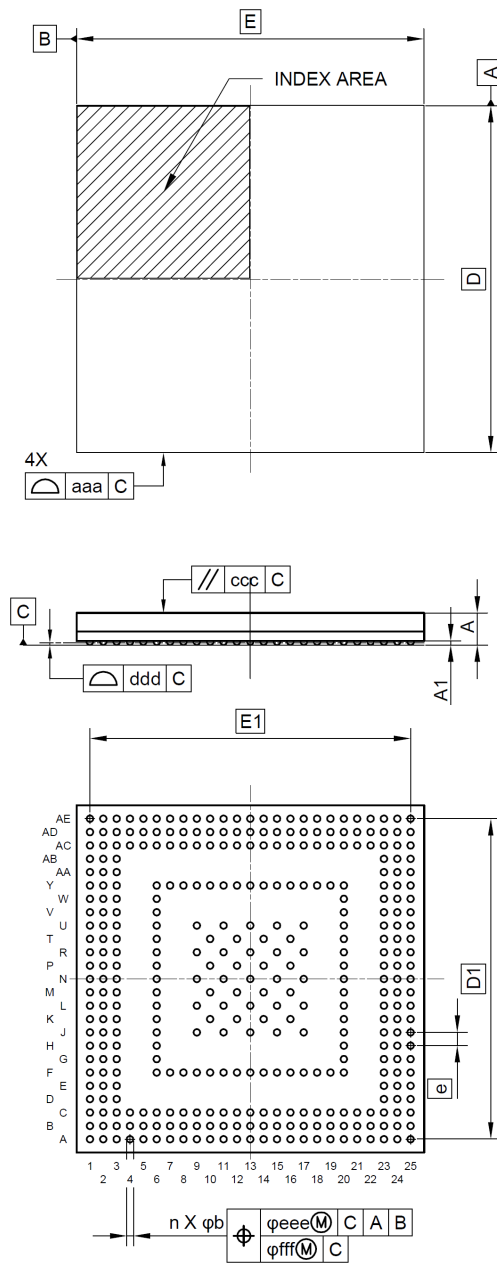

Figure 48.50 Watchdog Timer Output Timing

Appendix A Package Dimensions

JEITA Package code	RENESAS code	MASS(TYP.)[g]
P-LFBGA361-13x13-0.50	PLBG0361KB-A	0.40



Reference Symbol	Dimension in Millimeters		
	Min.	Nom.	Max.
D	—	13.00	—
E	—	13.00	—
D1	—	12.00	—
E1	—	12.00	—
A	—	—	1.40
A1	0.11	—	—
b	0.20	0.25	0.30
e	—	0.50	—
aaa	—	—	0.15
ccc	—	—	0.20
ddd	—	—	0.08
eee	—	—	0.15
fff	—	—	0.08
n	—	361	—

Appendix A.1 Package Dimensions (361-pin BGA, 13-mm Square, 0.5-mm Pitch)

JEITA Package code	RENESAS code	MASS(TYP.)[g]
P-LFBGA266-11x11-0.50	PLBG0266KA-A	0.29

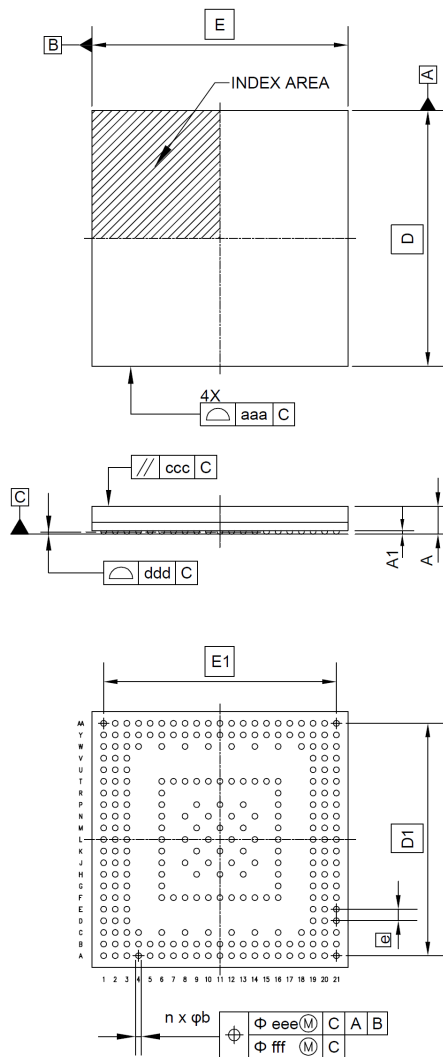

Reference Symbol	Dimension in Millimeters		
	Min.	Nom.	Max.
D	—	11.00	—
E	—	11.00	—
D1	—	10.00	—
E1	—	10.00	—
A	—	—	1.40
A1	0.11	—	—
b	0.20	0.25	0.30
e	—	0.50	—
aaa	—	—	0.15
ccc	—	—	0.20
ddd	—	—	0.08
eee	—	—	0.15
fff	—	—	0.08
n	—	266	—

Appendix A.2 Package Dimensions (266-pin BGA, 11-mm Square, 0.5-mm Pitch)

REVISION HISTORY	RZ/Five Group User's Manual: Hardware
------------------	---------------------------------------

Rev.	Date	Description	
		Page	Summary
1.00	Jun 30, 2022	—	First edition issued
1.10	Sep 26, 2022	1. Overview	
		51	1.1 Introduction, NOTE: The description "This LSI does not support TrustZone", added
		4. Boot Mode	
		64	4.1 Overview: Note added for starting the user program
		5. LSI Internal Bus	
		106	5.4.1.2 Determining the Security Levels of Bus Slaves: TrustZone, deleted
		7. Clock Pulse Generator (CPG)	
		353	7.4.5 Procedure for Switching the Division Ratio of the Dynamic Switching Frequency Dividers: The description "Division ratio setting (PLL1) register (CPG_PL1_DDIV)", added
		13. Address Space Controller (TZC)	
		427	13.1 Overview: TrustZone, deleted. NOTE, deleted.
427	13.1.1 Features: TrustZone system, deleted		
1.20	Jun 15, 2023	All	Hexadecimal notation, unified to H'xx
		1. Overview	
		52	1.2.1 CPU Core: System CPU AX45MP: Note 1, added to the description
		52	1.2.1 CPU Core: The description of Boot Mode 3 for Boot, modified
		57	1.2.8 Peripheral Module: Renesas Serial Peripheral Interface (RSPI): The description on the maximum transfer rate, deleted
		60	1.3 Product Lineup, added
		5. LSI Internal Bus	
		103, 104	Table 5.2 Accessible Areas (2/2): Slave Unit, changed (TZC (SRAM CPU) → TZC (SRAM ACPU)); TZC (SRAM MCPU), added
		6. System Controller (SYSC)	
		116	Table 6.1 SYSC Register Configuration (1/2): The initial value of the LSI device ID register (SYS_LSI_DEVID), modified
		146	6.3.31 LSI Mode Signal Register (SYS_LSI_MODE): Bit 16, changed (Reserved → the STAT_SEC_EN bit)
		7. Clock Pulse Generator (CPG)	
		166	Table 7.5 Register list (3/4): Monitor Register SYC (CPG_RSTMON_SYC): The initial value and the address, modified
		167	Table 7.5 Register list (4/4): Enable Pin Control Register GTM (CPG_EN_GTM), deleted
		167	Table 7.5 Register list (4/4): Clock Control Register MBUS (CPG_CLKON_MBUS) and Clock Monitor Register MBUS (CPG_CLKMON_MBUS), added
		—	7.2.4.138 Enable Pin Control Register GTM (CPG_EN_GTM), deleted
		319	7.2.4.139 WDT Reset Selector Register (CPG_WDTRST_SEL): Bit 24 (WDTRSTSEL8_WEN), bit 20 (WDTRSTSEL4_WEN), and bit 16 (WDTRSTSEL0_WEN), changed to reserved bits
		338	7.2.4.150 Clock Control Register MBUS (CPG_CLKON_MBUS), added
		339	7.2.4.151 Clock Monitor Register MBUS (CPG_CLKMON_MBUS), added
		355	7.4.6 Procedure for Switching Clocks by the Dynamic Switching Frequency Selectors: 2) Setting the switching of the clock output from SEL_PLL4: Setting of clocks switching: The description, modified
356	7.4.7 Procedure for Switching Clocks by the Static Switching Frequency Dividers and Selectors (Procedure for Switching Source Clocks): Note 1 and Note 2, added		

Rev.	Date	Description	
		Page	Summary
1.20	Jun 15, 2023	8. Interrupt Controller	
		393, 394	8.6.18 ECCRAM Error Interrupt Status Control Register0 (EREISR0): Bit in the table of bits, modified
		395, 396	8.6.19 ECCRAM Error Interrupt Status Control Register1 (EREISR1): Bit in the table of bits, modified
		10. On-chip RAM	
		415	The description (bit), modified
		21. Watchdog Timer (WDT)	
		851	Table 21.2 Pin Configuration: Note, added
		872	Table 21.6 WDT Reset Target by CPG_WDRST_SEL Register: The lines for Reserved, deleted
		22. Serial Communications Interface with FIFO (SCIFA)	
		934	Figure 22.24 Receive Data Sampling Timing in Asynchronous Mode: Receive data (RXD), modified
		23. Serial Communications Interface (SCIg)	
		937	Figure 23.1 Block Diagram of SCIg (SCI0 and SCI1): The pin name, modified (RTSn# → RTSn#, CTSn# → CTSn#)
		1006	Figure 23.33 Receive Data Sampling Timing in Smart Card Interface Mode (When Clock Frequency is 372 Times the Bit Rate): Receive data (RXDn), modified
		24. Renesas Serial Peripheral Interface	
		1041	Table 24.3 Relationship between SPBR and BRDV1 and BRDV0 Settings: The location of *1, modified. The bit rate for SPBR(n) = 0, modified.
		1051	Table 24.4 Relationship between Modes and SPCR and Description of Each Mode: Master (SPI Operation) for Transfer rate (in Mode), modified
		25. SPI Multi I/O Bus Controller	
		1104	25.4.17 Data Read DDR Enable Register (DRDREN): Bits 14 to 12, changed from reserved bits to the HYPE bits
		1139	Figure 25.20 Flow of Timing Adjustment when the Serial Flash Memory is Connected (DDR Mode): The figure title, modified. 13-step timing setting → 14-step timing setting. The values for y zz x, modified.
		26. I ² C Bus Interface	
		1150	26.3.1 RIICnCR1 — I ² C Bus Control Register 1: The description of bit 3 (SCL0), modified (SDA Output Control → SCL Output Control)
		30. Gigabit Ethernet Interface	
		1722	30.4.1.21 Error Interrupt Disable Register (EID): The description (register name), modified
		1884	Figure 30.31 Supported Frame of IPv4: Modified (ICMP/TCP/UDPTCP Data → ICMP/TCP/UDP Data)
		31. A/D Converter	
		1925	31.1 Features: The input channels and the data registers, modified
		1940	31.3.9 A/D Conversion Result Registers 3 to 0 (ADCR3 to ADCR0): The register, modified
		32. USB2.0	
		1975	Table 32.6 USBPHY Control Register List: VBUSEN control register, added
		1979	32.3.4 VBUSEN control register (VBENCTL), added
		32A. USB 2.0 Host Module	
		1990	32A.1.2.3 OTG function: The description of the OTG_PERI bit, modified
		2037	32A.2.4.3, (3) USBINTR Register: The section title, modified
		2049	32A.2.4.4 AHB Bridge Register: The offset address, deleted from the section title
		2062	32A.2.4.5 UCOM Register: The offset address, deleted from the section title
		2062	32A.2.4.5, (1) Common Control Register: The description of bit 31 (OTG_PERI), modified

Rev.	Date	Description	
		Page	Summary
1.20	Jun 15, 2023	2063	32A.2.4.5, (2) OTG-BC Interrupt Status Register: Bit 3 (VBSTAIN_T_STA) and bit 2 (VBSTACHG_STA), changed to reserved bits
		2064	32A.2.4.5, (3) OTG-BC Interrupt Enable Register: Bit 3 (VBSTAIN_T_EN) and bit 2 (VBSTACHG_EN), changed to reserved bits
		2066	32A.2.4.5, (5) Line Control Port 1 Register: Bits 25 and 24 (VDPMLLV_L[1:0]), changed to reserved bits
		2074	32A.4.2.3 U2H_EHCI_INT assertion source and control: [Interrupt enable control by register]: The description (bit), modified. [Interrupt source]: The row of bit [17], deleted. The description of bit[16] and bit[2], modified.
		2076	32A.4.2.5 U2H_OBINT assertion source and control: [Interrupt enable control by register]: The description (bits), modified; [Interrupt source]: The rows of bit [3], bit [2], deleted; The description of the VBUSIN pin for Interrupt Source (1, 2), deleted; [Clearing the interrupt]: The description (bits), modified
		2084	32A.8.3 Port Power (VBUS) control specifications: The description, modified
		40. SD/MMC Host Interface	
		2270	40.1.1 Features: The channels, added. NOTE, deleted.
		2276	40.2.2 Command Argument Register (SD_ARG): SD_ARG: Bits 63 to 32 (Reserved), added. SD_ARG1: Bits 63 to 16 (Reserved), added.
		2280	40.2.5 SD Card Response Registers (SD_RSP): SD_RSP5, modified (31 to 16 (Reserved) → 63 to 16 (Reserved))
		2291	40.2.10 SD Clock Control Register (SD_CLK_CTRL): The description of bits 7 to 0 (DIV7 to DIV0), modified
		2294	40.2.12 SD Card Access Control Option Register (SD_OPTION): The description of bit 15 (WIDTH), modified
		2303	40.2.23 SD Interface Mode Setting Register (SDIF_MODE): The description (mode), modified. Bit 0 (DDR), changed to a reserved bit.
		—	Figure 40.4 SDDAT in 4-Bit Width DDR Mode, deleted
		—	Figure 40.6 SDDAT in 8-Bit Width DDR Mode, deleted
		2313	40.3.1, (2) Bus Signal Voltage Switch: The description of (4), modified
		2349	Table 40.9 Example of SD_CMD Register Setting (MMC): The remark of CMD21, deleted
		41. General Purpose Input Output Port (GPIO)	
		2426	41.4.2 Operation for Peripheral Function: (2), The number of the functions, modified
		42. Low Power Mode	
		2431	Table 42.3 Registers for Module Standby Mode: The register name, modified (OSTM → GTM)
		45. Trusted Secure IP	
		2456	Table 45.1 Specifications of Trusted Secure IP (2/2): RSA for Encryption engine: Number of cycles for execution, added
		48. Electrical Characteristics	
		2476	Table 48.18 DC Characteristics (16) [ADC]: The Max. value of Analog input channel, changed
		2477	Table 48.19 DC Characteristics (17) [Current Consumption]: The maximum current of the power supply voltage (3.3 V) (PVDD), power supply voltage (1.1 V) (VDD), and power supply voltage (1.8 V) (VDD18), changed
		2479	Figure 48.5 Power-On Oscillation Settling Time: CPUHOLD、SEC_EN, deleted
		2479	Figure 48.6 Oscillation Settling Time on Return from Standby (Return by Reset): CPUHOLD、SEC_EN, deleted
		2494	Figure 48.26 Timing for Switching the Buffers On and Off, modified (t_{SOFF} → t_{BOFF})
		2508	Table 48.41 Renesas Serial Peripheral Interface Timing: The max. value of Data output delay time (tOD), modified

Rev.	Date	Description	
		Page	Summary
1.30	Jun 30, 2025	1. Overview	
		55	1.2.5 Sound Interface Sampling Rate Converter, deleted
		61	1.4 Pin, added
		5. LSI Internal Bus	
		99	Figure 5.1 Configuration of LSI Internal Bus Text, modified (MPU Bus → MCPU Bus) SRC, deleted
		103	Table 5.1 Detailed Address Space (3/3) Start addresses H'0_1004_7000, H'0_1004_0000: The "Space" column, modified
		104	Table 5.2 Accessible Areas Slave Unit: SRC (Memory/Reg), deleted
		110	Table 5.6 Bus Slaves for which the Security Levels are Determined by Using the Slave Control Registers Target Bus Slave for Control: SRC, deleted
		6. System Controller (SYSC)	
		133	6.3.9 Slave Access Control Register 5 (SYS_SLVACCCTL5) The main text, modified The bit name, R/W, and description of bits 5 and 4, modified
		7. Clock Pulse Generator (CPG)	
		158	Table 7.1 List of functions PLL control: The specification, modified (the description of PLL6, modified)
		163	7.1.4.2 Clock List The main text, modified
		165 to 167	Table 7.5 Register list Clock Control Register SRC, Clock Monitor Register SRC, Reset Control Register SRC, and Reset Monitor Register SRC, deleted
		—	7.2.4.31 Clock Control Register SRC (CPG_CLKON_SRC), deleted
		—	7.2.4.61 Clock Monitor Register SRC (CPG_CLKMON_SRC), deleted
		—	7.2.4.91 Reset Control Register SRC (CPG_RST_SRC), deleted
		—	7.2.4.121 Reset Monitor Register SRC (CPG_RSTMON_SRC), deleted
		318	7.2.4.137 MSTOP Register MCPU1 (CPG_BUS_MCPU1_MSTOP) The bit name, R/W, and description of bit 3, modified
		323	7.2.4.139 MSTOP Register PERI_COM (CPG_BUS_PERI_COM_MSTOP) The bit names, R/W, and descriptions of bits 23 to 21 and 7 to 5, modified
		331	7.2.4.143 MSTOP Register REG1 (CPG_BUS_REG1_MSTOP) The bit names, R/W, and descriptions of bits 23 and 7, modified
		348	7.4.2 Procedures for Supplying and Stopping Reset Signals Supplying a Reset Signal: The description, modified (the description of step 2, added. Bit 0 (UNIT0_RSTB) = 1 → Bit 0 (UNIT0_RSTB) = 0) Stopping a Reset Signal: The description, modified (Bit 0 (UNIT0_RSTB) = 0 → Bit 0 (UNIT0_RSTB) = 1)
		8. Interrupt Controller	
		363	Table 8.2 Interrupt mapping The "Cause of Interrupt" column, modified (TCIU8 → —)
		366	Table 8.2 Interrupt mapping The "Interrupt Source", "Cause of Interrupt", and "Interrupt Type" columns for interrupt IDs 374, 375, 376, 377, and 378, modified

Rev.	Date	Description	
		Page	Summary
1.30	Jun 30, 2025	14. Direct Memory Access Controller	
		457	14.4.9 Channel Configuration Register n/nS (CHCFG_n/nS) The description of bits 10 to 8, modified
		479	Table 14.3 On-Chip Module Requests Request Source: SRC, deleted
		522	14.9 Points for Caution, added
		17. Port Output Enable 3 (POE3)	
		820	Table 17.6 Correspondence between MTU Pins, modified
		22. Serial Communications Interface with FIFO (SCIFA)	
		888	Table 22.6 Bit Rates and BRR Register Settings in Asynchronous Mode The "n" column for the bit rate of 600 (bps), modified
		891	22.2.9 Modulation Duty Register (MDDR) When the baud rate generator is in double-speed mode (SEMR.BGDM = 1): The formula when operating on the base clock with a frequency 8 times the bit rate (SEMR.ABCS0 = 1), modified
		23. Serial Communications Interface (SCIg)	
		960	Table 23.6 Relationship between N Setting in BRR and Bit Rate B Smart card interface: The "BRR Setting" and "Error" columns, modified
		25. SPI Multi I/O Bus Controller	
		1081	Table 25.2 Register Configuration Manual mode read data register 1 and Manual mode write data register 1, deleted
		1099	25.4.13 Manual Mode Read Data Register 0 (SMRDR0) Note, modified
		27. Serial Sound Interface (SSIF-2)	
		1239	Figure 27.2 SSIF-2 Block Diagram Text, modified (Peripheral clock → Peripheral bus)
		1279	27.4.1.4 FIFO Status Register (SSIFSR): The title, modified The bit name of bits 13 to 8, modified TDC[5:0] Bits: The description, modified (H'10 → H'20) TDE Bit: The description, modified (SSIFCR.TTRG → SSISCR.TDES)
		1295	27.4.2.2 Monaural Format The main text, modified (SSICR.FLM → SSICR.FRM)
		28. CANFD Interface (RS-CANFD)	
		1335	Figure 28.1 RS-CANFD Module Block Diagram (Classical CAN Mode), modified
		29. Sampling Rate Converter (SRC), deleted	
		30. Gigabit Ethernet Interface	
		1669	Table 30.2 External pin Interface, modified
		41. General Purpose Input Output Port (GPIO)	
		2346	Figure 41.1 P0_0 to P0_3, P5_0 to P6_4, P11_0 to P18_5, P19_1 to P28_5 (Multiplexed peripheral functions) Note 1, modified
		2361	41.2.6 Interrupt Enable Control Register (ISEL) Registers ISEL06, ISEL07, ISEL0B_L, ISEL0B_H, ISEL0C, ISEL0F_L, and ISEL0F_H, deleted
		2375	Table 41.3 Correspondence between register and each terminal Notes 2, 3, and 4, added
		2377	Table 41.4 Correspondence between register and each terminal Notes 1 and 2, added

Rev.	Date	Description	
		Page	Summary
1.30	Jun 30, 2025	2380	Table 41.6 Correspondence between register and each terminal ISEL06, ISEL07, ISEL0B_L, ISEL0B_H, ISEL0C, ISEL0F_L, and ISEL0F_H, deleted
		2400	41.3.16 Ether MII/RGMII Mode Control Register (ETH MII/RGMII) The description of bits 1 and 0, modified
		42. Low Power Mode	
		2410	42.2.2.1 Setting of Clock control and MSTOP register When exiting the Module Standby Mode: The description, modified
		2410	Table 42.3 Registers for Module Standby Mode Target module for Module Standby Mode: SRC, deleted
		48. Electrical Characteristics	
		2451	Table 48.3 DC Characteristics (1) [3.3-V I/O] Input leakage current, added
		2452	Table 48.7 DC Characteristics (5) [RGMII/MII] Input logic low (Remarks: 1.8-V RGMII/MII): The Min value, modified
		2453	Table 48.9 DC Characteristics (7) [1.8 V I/O (SD, QSPI)] Output logic high voltage: The Min value, modified Output logic low voltage: The Max value, modified
		2455	Table 48.18 DC Characteristics (16) [ADC] Full-scale error, Offset error, Analog input capacitance, Analog input resistance, External capacitance, and External resistance, added Note 1, added
		2456	Figure 48.4 Analog Input Equivalent Circuit, added
		2457	Table 48.19 DC Characteristics (17) [Current Consumption] Power supply voltage (SD/3.3V), Power supply voltage (SPI/3.3V): The Max Current values, modified
		2460	Table 48.21 SDHC AC Access Timing (SDR at 3.3-V Operation) SD_CLK clock high level width, SD_CLK clock low level width, SD_CMD,SD_DATA output delay: The Min values, modified
		2461	Table 48.22 eMMC Host Interface Timing (MMC Default 3.3-V Power Supply) SD0_CLK clock cycle, SD0_CLK clock high level width, SD0_CLK clock low level width, SD0_CMD/SDDAT output delay: The Min values, modified
		2461	Table 48.23 eMMC Host Interface Timing (MMC Default 1.8-V Power Supply) SD0_CLK clock cycle, SD0_CLK clock high level width, SD0_CLK clock low level width: The Min values, modified SD0_CMD/SDDAT output delay: The Min and Max values, modified
		2462	48.5.3.2 eMMC host interface timing (HS-SDR), modified
		2463	Table 48.26 eMMC Host Interface Timing (HS200 1.8-V Power Supply Operation, Output Load 15 pF) SD0_CLK clock high level width, SD0_CLK clock low level width: The Min values, modified SD0_CMD/SDDAT output delay: The Min and Max values, modified
		2469	Table 48.32 Ethernet-IF Access Timing (Ether RGMII) Duty cycle for gigabit: The Min and Max values, modified Note, modified
		2473	Table 48.34 SPI Multi I/O Bus Controller Access Timing Clock cycle: The Min value at 1.8 V, modified
		2493	Appendix A Package Dimensions, added

RZ/Five Group User's Manual: Hardware

Publication Date: Rev.1.00 Jun 30, 2022
 Rev.1.30 Jun 30, 2025

Published by: Renesas Electronics Corporation

RZ/Five Group



Renesas Electronics Corporation

R01UH0986EJ0130