

Contents

1. Introduction2
 1.1 System Requirements2
 2. Getting Started2
 3. Input Parameters3
 4. Examples of Usage5
 4.1 Usage as a Standalone VI5
 4.2 Usage as a SubVI7
 5. Error Codes7
 6. Revision History8

List of Figures

Figure 1. Example Content of Spatial Angle and Analog Output Values in CSV Files2
 Figure 2. VI Front Panel3
 Figure 3. Example of Usage as a Standalone VI5
 Figure 4. Example of Writing Coefficients into the “MEMORY EDIT” Tab6
 Figure 5. ZMID520x_dll_64.vi Connector Pane7

List of Tables

Table 1. User Entries4
 Table 2. Possible Error Codes in the “Result Code” Display Field7

1. Introduction

This document describes how to setup and use the Calibration Dynamic Link Library (DLL) in combination with a virtual instrument (VI) in National Instruments™ LabVIEW to perform calibration and linearization on the ZMID520x Inductive Position Sensor IC. After the VI has been run, it will produce the new coefficients to write into the memory of the ZMID520x.

1.1 System Requirements

- Microsoft Windows® 7 SP1 x64, Microsoft Windows® 8 x64, Microsoft Windows® 10 x64
- National Instruments™ LabVIEW 2016 x64 or higher

2. Getting Started

1. Navigate to the web page for the applicable product:
 - ZMID5201: www.IDT.com/zmid5201
 - ZMID5202: www.IDT.com/zmid5202
 - ZMID5203: www.IDT.com/zmid5203
2. Under “Software and Tools,” download the zip files for the DLL and the VI graphical programming language file. Extract the contents of the folder after downloading has completed.
3. A CSV file containing spatial angle points, analog output points, Pulse Width Modulation (PWM) output points, or Single Edge Nibble Transmission (SENT) output points is required as an input to run the VI. Figure 1 shows a list of example values demonstrating the format that must be used. If the values have decimal points, a period must be used as the decimal separator (not a comma).

Figure 1. Example Content of Spatial Angle and Analog Output Values in CSV Files

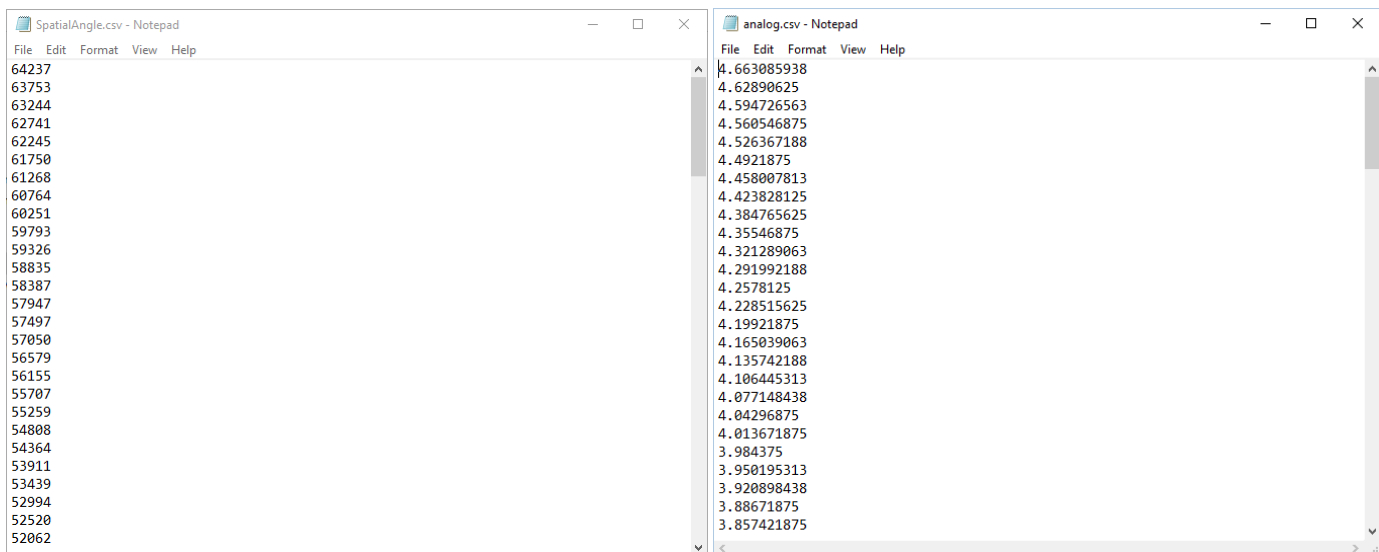

3. Input Parameters

Open "ZMID520x_dll_64.vi" (Figure 2). Table 1 shows the eleven input parameters. After all input fields are filled in, run the VI. The calculated coefficients will be available, if the "Result Code" is equal to "0", otherwise there is an error and the coefficients are not valid.

Figure 2. VI Front Panel

The screenshot shows the front panel of the "ZMID520x DLL Path" VI. It is divided into several sections:

- Top Section:** Contains "ZMID520x DLL Path" and "CSV Path" file selection fields, and a "DLL Version" numeric field set to 0.
- Input Parameters Section:**
 - ZMID Type:** Dropdown menu set to "ZMID5201".
 - Output Data Type:** Dropdown menu set to "Spatial Angle".
 - Position Slope:** Dropdown menu set to "Negative".
 - Reverse Slope:** Dropdown menu set to "No".
 - Out Min:** Numeric field set to 5.
 - Out Max:** Numeric field set to 95.
 - Out Min/Max in Percent:** A slider control currently positioned at approximately 25%.
 - Out Mode:** Dropdown menu set to "Linear".
 - VDD:** Numeric field set to 5.
- Output Parameters Section:**
 - Offset:** Numeric field set to 0.
 - Offset Register (Hex):** Numeric field set to 0.
 - Slope:** Numeric field set to 0.
 - Slope Register (Hex):** Numeric field set to 0.
 - Correction:** A vertical list of 8 numeric fields, all set to 0.
 - Correction Register (Hex):** A vertical list of 8 numeric fields, all set to 0.
 - Clamp Low:** Numeric field set to 0.
 - Clamp High:** Numeric field set to 0.
 - Clamp Register (Hex):** Numeric field set to 0.
- Bottom Section:**
 - error in (no error):** A sub-panel with "status" (green checkmark), "code" (0), and "source" (empty dropdown).
 - error out:** A sub-panel with "status" (green checkmark), "code" (0), and "source" (empty dropdown).
 - Result Code:** Numeric field set to 0.
 - Result Message:** Empty text field.

Table 1. User Entries

| Input Parameter | Description |
|------------------------|--|
| ZMID520x DLL Path | Full path of the location of the DLL |
| CSV Path | Full path of the location of the CSV |
| ZMID Type | 1 = ZMID5201 (analog output), 2 = ZMID5202 (PWM), 3 = ZMID5203 (SENT) |
| Output Data Type | The type of the data contained in the CSV file: 0 = Spatial Angle, 1 = Analog, 2 = PWM, 3 = SENT |
| Position Slope | The slope of the list of points: 0 = positive, 1 = negative |
| Reverse Slope | This option can reverse the slope: 0 = keep the slope as is, 1 = invert the slope |
| Out Min | Lower clamping value: 5 = no clamping ^[a] |
| Out Max | Higher clamping value: 95 = no clamping ^[a] |
| Out Min/Max in Percent | Choose whether “Out Min” and “Out Max” are going to be filled in as percent of the output or as raw values by clicking this toggle button. |
| Out Mode | Output mode of the chip: 0 = Linear output mode, 1 = Modulo360 output mode |
| VDD | The power supply of the ZMID520x ^[b] |

[a] ZMID5203 does not have clamping for the values.

[b] The power supply of the ZMID520x is needed only if using analog points as the “Output Data Type.”

Write the generated coefficients into the respective registers in the chip. One way to do this is with the ZMID520x EVK Application Software which is a graphical user interface (GUI) found on the ZMID520x product web page (see section 2).

4. Examples of Usage

4.1 Usage as a Standalone VI

The following lines are an example of how to fill in the parameters using a ZMID5201 (analog output) and spatial angle points. In this example, the output mode is set to linear, the slope is negative and not inverted, and clamping is set to 5% to 95%. For the ZMID5201, refer to the *ZMID5201 Manual for Calibration and Linearization Using the Analog Output* for more details regarding the parameter definitions.

Figure 3. Example of Usage as a Standalone VI

ZMID520x DLL Path: C:\ZMID520X_OneStepCalibration_64.dll | DLL Version: 1.3

CSV Path: C:\SpatialAngle.csv

Input Parameters

ZMID Type: ZMID5201 | Output Data Type: Spatial Angle

Position Slope: Negative | Reverse Slope: No

Out Min: 5 | Out Max: 95

Out Min/Max in Percent:

Out Mode: Linear | VDD: 5

Output Parameters

Offset: 33.8928 | Offset Register (Hex): 233F

Slope: 1.12861 | Slope Register (Hex): 483

| Correction | Correction Register (Hex) |
|------------|---------------------------|
| 1 | 1 |
| -5 | 85 |
| -2 | 82 |
| -1 | 81 |
| 5 | 5 |
| 5 | 5 |
| 4 | 4 |
| -1 | 81 |
| 0 | 0 |

Clamp Low: 5 | Clamp High: 95 | Clamp Register (Hex): 0

error in (no error)

| status | code |
|--------|------|
| ✓ | 0 |

source: []

error out

| status | code |
|--------|------|
| ✓ | 0 |

source: []

Result Code: 0

Result Message: SUCCESS

After the coefficients are calculated, they appear on “Output Parameters” section. The fields must be written to the ZMID5201 memory at the following addresses for these example values.

Address 0x00: 233F (“Offset Register” field)

Address 0x01: 0483 (“Slope Register” field)

Address 0x02: 0000 (“Clamp Register” field)

Address 0x03: 8501 (first two “Correction Register” fields)

Address 0x04: 8182 (next two “Correction Register” fields)

Address 0x05: 0505 (next two “Correction Register” fields)

Address 0x06: 8104 (next two “Correction Register” fields)

Address 0x07: 0000 (last “Correction Register” field as lower byte with upper byte filled with 00_{HEX})

In the GUI, the new coefficients can be written into the ZMID5201 EEPROM by entering them in the “MEMORY EDIT” tab and then clicking “Write EEPROM” button.

Figure 4. Example of Writing Coefficients into the “MEMORY EDIT” Tab

The screenshot shows the ZMID5201 application interface. The 'MEMORY EDIT' tab is active, displaying two tables of registers. The top table is for EEPROM and the bottom table is for SWR. The EEPROM table shows values for addresses 0h to 7h. The SWR table shows values for addresses 0h to 7h. A red text note at the bottom of the table area states: "Register values in red are different than actual values in chip memory. You need to write them to chip memory in order to take effect."

| EEPROM | 0 | 1 | 2 | 3 | 4 | 5 | 6 | 7 |
|--------|------|------|------|------|------|------|------|------|
| 0h | 233F | 0483 | 0000 | 8501 | 8182 | 0505 | 8104 | 0000 |
| 8h | 1000 | 1100 | 0802 | B103 | 0838 | 0055 | BFFF | 0000 |
| 10h | 0000 | 00C2 | | | | | | |

| SWR | 0 | 1 | 2 | 3 | 4 | 5 | 6 | 7 |
|-----|------|------|------|------|------|------|------|------|
| 0h | 17A6 | 0400 | 0000 | 0000 | 0000 | 0000 | 0000 | 0000 |
| 8h | 1000 | 1100 | 0802 | B103 | 0838 | 0055 | BFFF | |
| 10h | | 00C2 | | 0380 | 0E7B | 0B1A | 4AB7 | 1E11 |
| 18h | A55B | 46C3 | 46C3 | 0001 | | | | |

Register values in red are different than actual values in chip memory. You need to write them to chip memory in order to take effect.

4.2 Usage as a SubVI

The VI can be used as sub-block in other VIs. The connector pane is shown in Figure 5. If an error occurs, as displayed in the “error in” input section, the code of the VI is not executed and the error is transported to the “error out” output.

Note: The clamping parameters do not apply to the ZMID5203.

Figure 5. ZMID520x_dll_64.vi Connector Pane

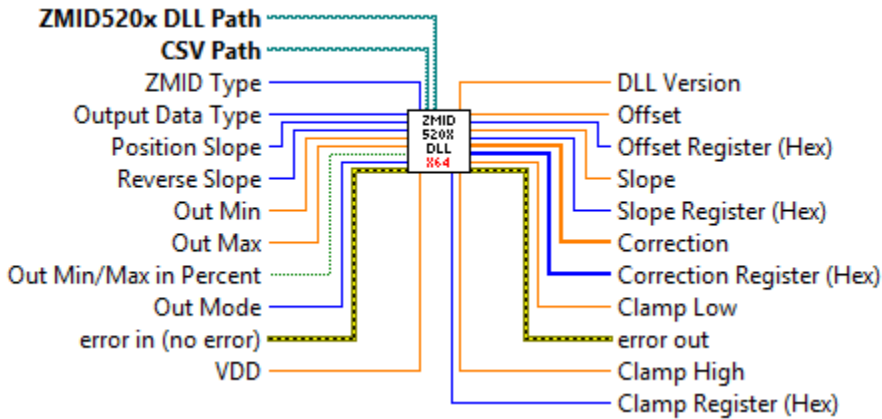

5. Error Codes

If the run is successful, “0” will be displayed in the “Result Code” field and “SUCCESS” will appear in the “Result Message” field. If instead there has been an error, a negative error code will be displayed in “Result Code” and the corresponding error name will be displayed in “Result Message” field. Table 2 defines the DLL error codes and names.

Table 2. Possible Error Codes in the “Result Code” Display Field

| Error Code | Error Name | Description |
|---------------|-------------------|---|
| Error code -1 | ERR_INVALID_INPUT | One or more of the inputs are invalid. |
| Error code -2 | ERR_SLOPE | The calculated slope is out of range. |
| Error code -3 | ERR_OFFSET | The calculated offset is out of range. |
| Error code -4 | ERR_CORR | One or more of the calculated correction values are out of range. |
| Error code -5 | ERR_POS0 | One or more of the calculated Pos0 values are out of range. |
| Error code -6 | ERR_POS1 | One or more of the calculated Pos1 values are out of range. |

6. Revision History

| Revision Date | Description of Change |
|---------------|-----------------------|
| July 23, 2018 | Initial release |

IMPORTANT NOTICE AND DISCLAIMER

RENESAS ELECTRONICS CORPORATION AND ITS SUBSIDIARIES (“RENESAS”) PROVIDES TECHNICAL SPECIFICATIONS AND RELIABILITY DATA (INCLUDING DATASHEETS), DESIGN RESOURCES (INCLUDING REFERENCE DESIGNS), APPLICATION OR OTHER DESIGN ADVICE, WEB TOOLS, SAFETY INFORMATION, AND OTHER RESOURCES “AS IS” AND WITH ALL FAULTS, AND DISCLAIMS ALL WARRANTIES, EXPRESS OR IMPLIED, INCLUDING, WITHOUT LIMITATION, ANY IMPLIED WARRANTIES OF MERCHANTABILITY, FITNESS FOR A PARTICULAR PURPOSE, OR NON-INFRINGEMENT OF THIRD-PARTY INTELLECTUAL PROPERTY RIGHTS.

These resources are intended for developers who are designing with Renesas products. You are solely responsible for (1) selecting the appropriate products for your application, (2) designing, validating, and testing your application, and (3) ensuring your application meets applicable standards, and any other safety, security, or other requirements. These resources are subject to change without notice. Renesas grants you permission to use these resources only to develop an application that uses Renesas products. Other reproduction or use of these resources is strictly prohibited. No license is granted to any other Renesas intellectual property or to any third-party intellectual property. Renesas disclaims responsibility for, and you will fully indemnify Renesas and its representatives against, any claims, damages, costs, losses, or liabilities arising from your use of these resources. Renesas' products are provided only subject to Renesas' Terms and Conditions of Sale or other applicable terms agreed to in writing. No use of any Renesas resources expands or otherwise alters any applicable warranties or warranty disclaimers for these products.

(Disclaimer Rev.1.01)

Corporate Headquarters

TOYOSU FORESIA, 3-2-24 Toyosu,
Koto-ku, Tokyo 135-0061, Japan
www.renesas.com

Trademarks

Renesas and the Renesas logo are trademarks of Renesas Electronics Corporation. All trademarks and registered trademarks are the property of their respective owners.

Contact Information

For further information on a product, technology, the most up-to-date version of a document, or your nearest sales office, please visit www.renesas.com/contact-us/.