

SLG47115V Socket Adapter GreenPAK TQFN-20 #5

This document describes the functionality of the SLG47115V Socket Adapter GreenPAK TQFN-20 #5 and provides a quick start guide.

Contents

1. Introduction and Board Overview 2

 1.1 Electrical Specifications 2

 1.2 Pinout..... 3

2. Design Emulation, Programming, and Real-Time Testing 4

3. Board Dimensions 5

4. Schematic Diagrams 6

5. Bill of Materials 7

6. Terms and Definitions 7

7. References..... 7

8. Ordering Information..... 7

9. Revision History 7

Figures

Figure 1. Socket Adapter Pinout Description.....2

Figure 2. Using Advanced Development Board4

Figure 3. Using Light Development Board.....4

Figure 4. Board Assembly Top View Dimensions5

Figure 5. Board Assembly Side View Dimensions5

1. Introduction and Board Overview

The Socket Adapter GreenPAK TQFN-20 #5 is a compact, easy-to-use hardware tool that provides hardware support for the SLG47115V IC, enabling design emulation, programming, and real-time testing. The socket adapter is plugged into one of the development boards, which in its turn is controlled by the Go Configure Hub software ([2]) for both emulation and IC programming.

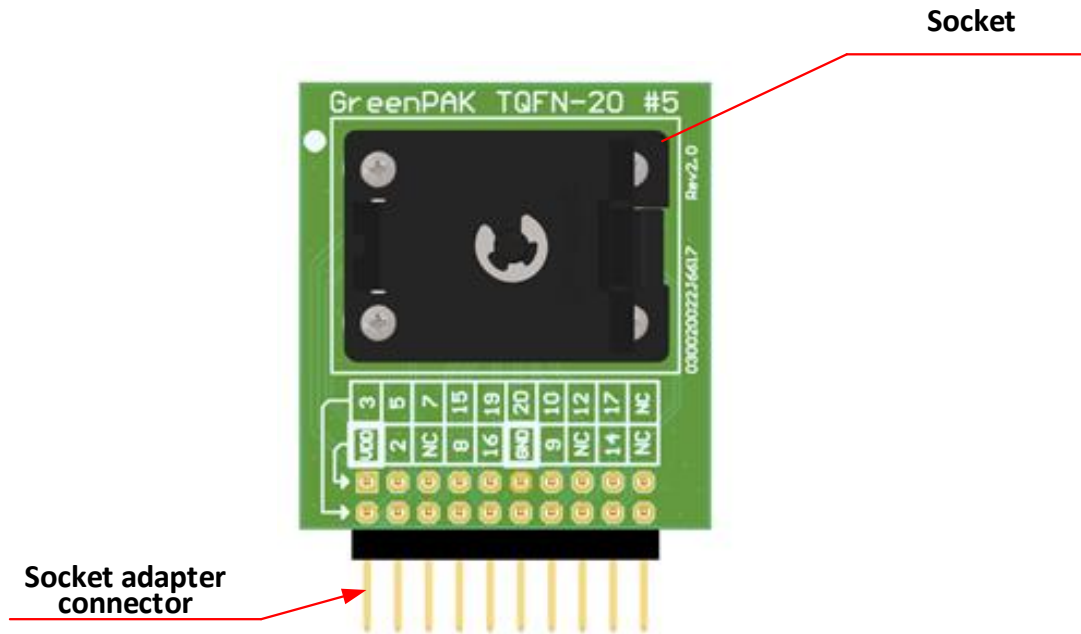

Figure 1. Socket Adapter Pinout Description

Note 1: PIN1 (VDD), PIN6 (VDD2), and PIN11 (VDD2) are connected in the TQFN-20 #5 socket adapter. Therefore, the maximum operating conditions for the VDD2 high-voltage groups are limited to those of the VDD group.

Note 2: PIN4 (GND_HV), PIN13 (GND_HV), and PIN18 (GND) are connected in the TQFN-20 #5 socket adapter.

Note 3: The TQFN-20 #5 socket adapter is intended only for functional testing without high voltage or high current load.

1.1 Electrical Specifications

The SLG47115V Socket Adapter GreenPAK TQFN-20 #5 maximum ratings are:

- Maximum V_{DD} voltage: 50 V
- Maximum current rating: 1 A per pin

SLG47115V Socket Adapter GreenPAK TQFN-20 #5

1.2 Pinout

Table 1. Socket Adapter Pinout Description

Chip Pin #	SA Connector J1 Pin #	Pin Functions
1	VDD	Power Supply
2	TP3	GPIO, Vref OUT, Diff Amp Vset Input, TS_OUT
3	TP2	GPI, EXT_Vref0, SLA_0
4	GND	Analog Ground
5	TP4	Winding Sense, relate to HV_GPO0_HD, HV_GPO1_HD
6	VDD	High Voltage Power Supply
7	TP6	HV_GPO0_HD
8	TP7	HV_GPO0_HD
9	TP13	HV_GPO1_HD
10	TP14	HV_GPO1_HD
11	VDD	High Voltage Power Supply
12	TP16	Winding Sense, relate to HV_GPO0_HD, HV_GPO1_HD
13	GND	Analog Ground
14	TP17	GPIO, SLA_1, EXT_CLK for OSC0 or Current Sense CMP EXT_Vref
15	TP8	SCL, GPIO
16	TP9	SDA, GPIO
17	TP18	GPIO, EXT_Vref1, SLA_2, EXT_CLK for OSC1
18	GND	General Ground
19	TP10	GPIO, ACMP0_H
20	TP12	GPIO, SLA_3, ACMP1_H

2. Design Emulation, Programming, and Real-Time Testing

To use the socket adapter, it is necessary to place the SLG47115V into it and then connect the socket to the Advanced Development Board or Light Development Board (see **Figure 2** and **Figure 3**).

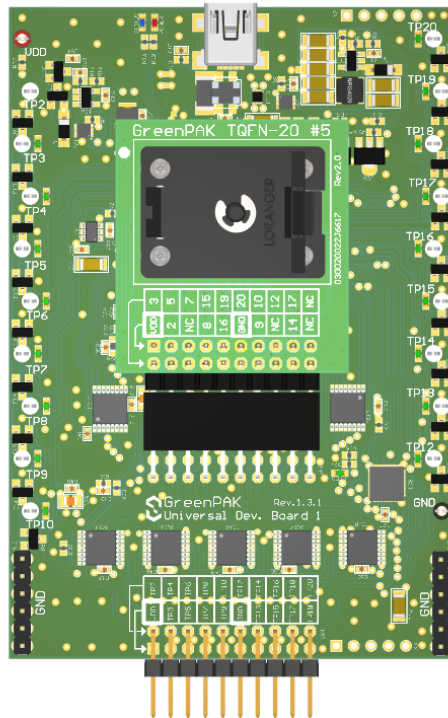

Figure 2. Using Advanced Development Board

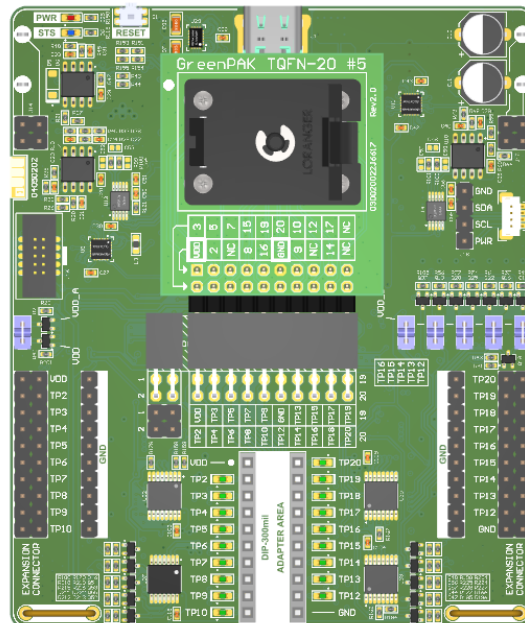

Figure 3. Using Light Development Board

3. Board Dimensions

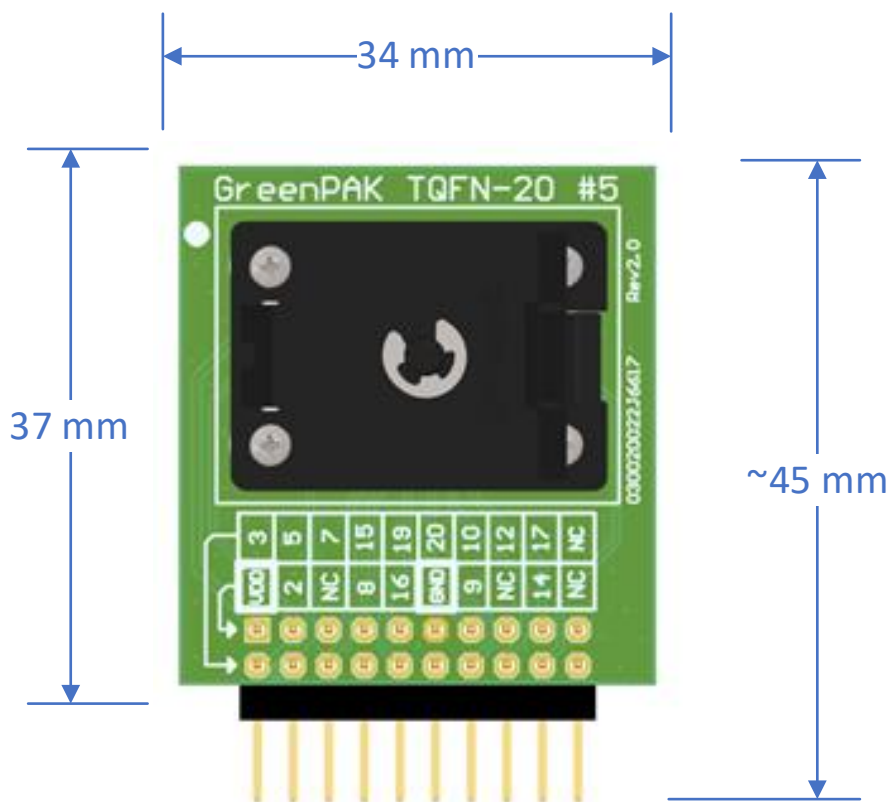
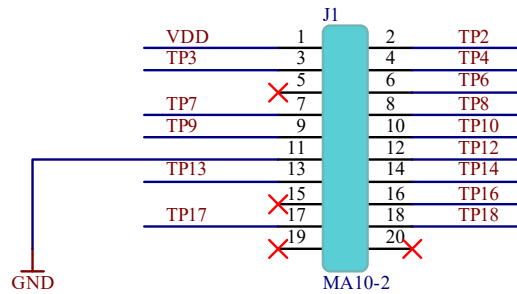
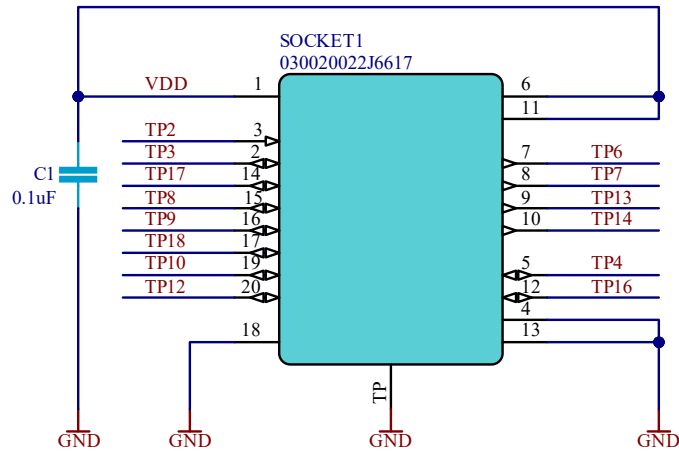

Figure 4. Board Assembly Top View Dimensions



Figure 5. Board Assembly Side View Dimensions

4. Schematic Diagrams



5. Bill of Materials

#	Designator	Name	Manufacturer Part Number	Manufacturer 1	Quantity
1	BP1	SJ61A6	7010334512	3M	1
2	C1	0.1 µF 10 % 50 V X7R 0402	CL05F104ZO5NNNC	Samsung	1
3	J1	68021-220HLF	68021-220HLF	Amphenol ICC / FCI	1
4	SOCKET1	TQFN-20, 2 mm x 3 mm	030020022J6617	Loranger	1

6. Terms and Definitions

GPIO	General Purpose Input/Output
IC	Integrated Circuit
SA	Socket Adapter
TP	Test point

7. References

- [1] [SLG47115](#), Datasheet, Renesas Electronics.
- [2] [Go Configure Software Hub](#), Software Download, and User Guide.

8. Ordering Information

Part Number	Description
SLG4SA20HV-20x30	GreenPAK TQFN-20 #5 Socket Adapter
SLG47115V-SKT	SLG4SA20HV-20x30 socket adapter, 50 SLG47115V samples

9. Revision History

Revision	Date	Description
1.03	Mar 3, 2026	Fixed typos
1.02	Feb 23, 2026	Corrected Socket Adapter Pinout Description table
1.01	Feb 19, 2026	Added Ordering Information Added socket adapter Electrical specification Corrected socket description in Introduction and Board Overview section Added description to Design Emulation, Programming, and Real-Time Testing section
1.00	Jan 14, 2026	Initial release.

IMPORTANT NOTICE AND DISCLAIMER

RENESAS ELECTRONICS CORPORATION AND ITS SUBSIDIARIES (“RENESAS”) PROVIDES TECHNICAL SPECIFICATIONS AND RELIABILITY DATA (INCLUDING DATASHEETS), DESIGN RESOURCES (INCLUDING REFERENCE DESIGNS), APPLICATION OR OTHER DESIGN ADVICE, WEB TOOLS, SAFETY INFORMATION, AND OTHER RESOURCES “AS IS” AND WITH ALL FAULTS, AND DISCLAIMS ALL WARRANTIES, EXPRESS OR IMPLIED, INCLUDING, WITHOUT LIMITATION, ANY IMPLIED WARRANTIES OF MERCHANTABILITY, FITNESS FOR A PARTICULAR PURPOSE, OR NON-INFRINGEMENT OF THIRD-PARTY INTELLECTUAL PROPERTY RIGHTS.

These resources are intended for developers who are designing with Renesas products. You are solely responsible for (1) selecting the appropriate products for your application, (2) designing, validating, and testing your application, and (3) ensuring your application meets applicable standards, and any other safety, security, or other requirements. These resources are subject to change without notice. Renesas grants you permission to use these resources only to develop an application that uses Renesas products. Other reproduction or use of these resources is strictly prohibited. No license is granted to any other Renesas intellectual property or to any third-party intellectual property. Renesas disclaims responsibility for, and you will fully indemnify Renesas and its representatives against, any claims, damages, costs, losses, or liabilities arising from your use of these resources. Renesas' products are provided only subject to Renesas' Terms and Conditions of Sale or other applicable terms agreed to in writing. No use of any Renesas resources expands or otherwise alters any applicable warranties or warranty disclaimers for these products.

(Disclaimer Rev.1.01)

Corporate Headquarters

TOYOSU FORESIA, 3-2-24 Toyosu,
Koto-ku, Tokyo 135-0061, Japan
www.renesas.com

Trademarks

Renesas and the Renesas logo are trademarks of Renesas Electronics Corporation. All trademarks and registered trademarks are the property of their respective owners.

Contact Information

For further information on a product, technology, the most up-to-date version of a document, or your nearest sales office, please visit www.renesas.com/contact-us/.