

RH850 Evaluation Platform

RH850/X2X Main Board

User's Manual

Y-RH850-X2X-MB-T1-V1

Y-RH850-X2X-MB-T1-V1-JP

The newest version of this document can be obtained from the following web location:

[Y-RH850-X2X-MB-T1-V1](https://www.renesas.com/y-rh850-x2x-mb-t1-v1)

All information contained in these materials, including products and product specifications, represents information on the product at the time of publication and is subject to change by Renesas Electronics Corp. without notice. Please review the latest information published by Renesas Electronics Corp. through various means, including the Renesas Electronics Corp. website (<https://www.renesas.com>)

Notice

1. Descriptions of circuits, software and other related information in this document are provided only to illustrate the operation of semiconductor products and application examples. You are fully responsible for the incorporation or any other use of the circuits, software, and information in the design of your product or system. Renesas Electronics disclaims any and all liability for any losses and damages incurred by you or third parties arising from the use of these circuits, software, or information.
 2. Renesas Electronics hereby expressly disclaims any warranties against and liability for infringement or any other claims involving patents, copyrights, or other intellectual property rights of third parties, by or arising from the use of Renesas Electronics products or technical information described in this document, including but not limited to, the product data, drawings, charts, programs, algorithms, and application examples.
 3. No license, express, implied or otherwise, is granted hereby under any patents, copyrights or other intellectual property rights of Renesas Electronics or others.
 4. You shall not alter, modify, copy, or reverse engineer any Renesas Electronics product, whether in whole or in part. Renesas Electronics disclaims any and all liability for any losses or damages incurred by you or third parties arising from such alteration, modification, copying or reverse engineering.
 5. Renesas Electronics products are classified according to the following two quality grades: "Standard" and "High Quality". The intended applications for each Renesas Electronics product depends on the product's quality grade, as indicated below.
"Standard": Computers; office equipment; communications equipment; test and measurement equipment; audio and visual equipment; home electronic appliances; machine tools; personal electronic equipment; industrial robots; etc.
"High Quality": Transportation equipment (automobiles, trains, ships, etc.); traffic control (traffic lights); large-scale communication equipment; key financial terminal systems; safety control equipment; etc.
Unless expressly designated as a high reliability product or a product for harsh environments in a Renesas Electronics data sheet or other Renesas Electronics document, Renesas Electronics products are not intended or authorized for use in products or systems that may pose a direct threat to human life or bodily injury (artificial life support devices or systems; surgical implantations; etc.), or may cause serious property damage (space system; undersea repeaters; nuclear power control systems; aircraft control systems; key plant systems; military equipment; etc.). Renesas Electronics disclaims any and all liability for any damages or losses incurred by you or any third parties arising from the use of any Renesas Electronics product that is inconsistent with any Renesas Electronics data sheet, user's manual or other Renesas Electronics document.
 6. When using Renesas Electronics products, refer to the latest product information (data sheets, user's manuals, application notes, "General Notes for Handling and Using Semiconductor Devices" in the reliability handbook, etc.), and ensure that usage conditions are within the ranges specified by Renesas Electronics with respect to maximum ratings, operating power supply voltage range, heat dissipation characteristics, installation, etc. Renesas Electronics disclaims any and all liability for any malfunctions, failure or accident arising out of the use of Renesas Electronics products outside of such specified ranges.
 7. Although Renesas Electronics endeavors to improve the quality and reliability of Renesas Electronics products, semiconductor products have specific characteristics, such as the occurrence of failure at a certain rate and malfunctions under certain use conditions. Unless designated as a high reliability product or a product for harsh environments in a Renesas Electronics data sheet or other Renesas Electronics document, Renesas Electronics products are not subject to radiation resistance design. You are responsible for implementing safety measures to guard against the possibility of bodily injury, injury or damage caused by fire, and/or danger to the public in the event of a failure or malfunction of Renesas Electronics products, such as safety design for hardware and software, including but not limited to redundancy, fire control and malfunction prevention, appropriate treatment for aging degradation or any other appropriate measures. Because the evaluation of microcomputer software alone is very difficult and impractical, you are responsible for evaluating the safety of the final products or systems manufactured by you.
 8. Please contact a Renesas Electronics sales office for details as to environmental matters such as the environmental compatibility of each Renesas Electronics product. You are responsible for carefully and sufficiently investigating applicable laws and regulations that regulate the inclusion or use of controlled substances, including without limitation, the EU RoHS Directive, and using Renesas Electronics products in compliance with all these applicable laws and regulations. Renesas Electronics disclaims any and all liability for damages or losses occurring as a result of your noncompliance with applicable laws and regulations.
 9. Renesas Electronics products and technologies shall not be used for or incorporated into any products or systems whose manufacture, use, or sale is prohibited under any applicable domestic or foreign laws or regulations. You shall comply with any applicable export control laws and regulations promulgated and administered by the governments of any countries asserting jurisdiction over the parties or transactions.
 10. It is the responsibility of the buyer or distributor of Renesas Electronics products, or any other party who distributes, disposes of, or otherwise sells or transfers the product to a third party, to notify such third party in advance of the contents and conditions set forth in this document.
 11. This document shall not be reprinted, reproduced or duplicated in any form, in whole or in part, without prior written consent of Renesas Electronics.
 12. Please contact a Renesas Electronics sales office if you have any questions regarding the information contained in this document or Renesas Electronics products.
- (Note 1) "Renesas Electronics" as used in this document means Renesas Electronics Corporation and also includes its directly or indirectly controlled subsidiaries.
- (Note 2) "Renesas Electronics product(s)" means any product developed or manufactured by or for Renesas Electronics.

General Precautions in the Handling of Microprocessing Unit and Microcontroller Unit Products

The following usage notes are applicable to all Microprocessing unit and Microcontroller unit products from Renesas. For detailed usage notes on the products covered by this document, refer to the relevant sections of the document as well as any technical updates that have been issued for the products.

1. Handling of Unused Pins

Handle unused pins in accordance with the directions given under Handling of Unused Pins in the manual.

- The input pins of CMOS products are generally in the high-impedance state. In operation with an unused pin in the open-circuit state, extra electromagnetic noise is induced in the vicinity of LSI, an associated shoot-through current flows internally, and malfunctions occur due to the false recognition of the pin state as an input signal become possible. Unused pins should be handled as described under Handling of Unused Pins in the manual.

2. Processing at Power-on

The state of the product is undefined at the moment when power is supplied.

- The states of internal circuits in the LSI are indeterminate and the states of register settings and pins are undefined at the moment when power is supplied.
In a finished product where the reset signal is applied to the external reset pin, the states of pins are not guaranteed from the moment when power is supplied until the reset process is completed.
In a similar way, the states of pins in a product that is reset by an on-chip power-on reset function are not guaranteed from the moment when power is supplied until the power reaches the level at which resetting has been specified.

3. Prohibition of Access to Reserved Addresses

Access to reserved addresses is prohibited.

- The reserved addresses are provided for the possible future expansion of functions. Do not access these addresses; the correct operation of LSI is not guaranteed if they are accessed.

4. Clock Signals

After applying a reset, only release the reset line after the operating clock signal has become stable. When switching the clock signal during program execution, wait until the target clock signal has stabilized.

- When the clock signal is generated with an external resonator (or from an external oscillator) during a reset, ensure that the reset line is only released after full stabilization of the clock signal. Moreover, when switching to a clock signal produced with an external resonator (or by an external oscillator) while program execution is in progress, wait until the target clock signal is stable.

5. Differences between Products

Before changing from one product to another, i.e. to a product with a different part number, confirm that the change will not lead to problems.

- The characteristics of Microprocessing unit or Microcontroller unit products in the same group but having a different part number may differ in terms of the internal memory capacity, layout pattern, and other factors, which can affect the ranges of electrical characteristics, such as characteristic values, operating margins, immunity to noise, and amount of radiated noise. When changing to a product with a different part number, implement a system-evaluation test for the given product.

Table of Contents

1.	Overview	7
1.1	Package Components	7
1.2	Applicable Piggyback Boards.....	8
1.3	Main Features	8
1.4	Extension Boards	8
1.5	Main Board Views	10
2.	Jumpers, Switches, Connectors and LEDs	11
2.1	Jumpers Overview.....	12
2.2	Switches Overview	16
2.3	Connectors Overview	18
2.4	LEDs Overview.....	21
3.	Power Supply	22
3.1	Circuit Diagram.....	22
3.2	Board Power Connection	23
3.3	Board Power Switch	23
3.4	VDDIOF Selection	23
3.5	Reverse Voltage Connection Protection	23
3.6	Voltage Level LEDs.....	23
4.	Peripheral Circuits	24
4.1	Piggyback Board	24
4.1.1	Piggyback Board Connectors.....	24
4.2	LIN Interfaces	30
4.2.1	Circuit Diagram.....	30
4.2.2	Connector Sharing	30
4.2.3	Power Supply Selection	31
4.2.4	LIN Signals Piggyback Board Connection	32
4.2.5	LIN Bus Loopback.....	32
4.2.6	LIN Interface Connectors	32
4.3	CAN Interfaces	34
4.3.1	Circuit Diagram.....	34
4.3.2	Power Supply	35
4.3.3	CAN Bus Termination	35
4.3.4	CAN Bus Loopback.....	35
4.3.5	CANn STB Control	35
4.3.6	CAN Interface Connectors	36
4.4	FlexRay Interfaces	37
4.4.1	Circuit Diagram.....	37
4.4.2	Signal Connections	37

4.4.3	Power Supply	37
4.4.4	Control Signals	38
4.4.5	FlexRay Connectors	39
4.5	SENT (Single Edge Nibble Transmission) Interfaces	40
4.5.1	Circuit Diagram	40
4.5.2	SENT Interface Connectors	41
4.6	UART Interfaces	42
4.6.1	Circuit Diagram	42
4.6.2	UART Connector	43
4.7	Connection Cable for various Interfaces	44
4.8	Ethernet Modules	45
4.8.1	Circuit Diagram of Ethernet Connectors	46
4.8.2	Pin Assignments of Ethernet Connectors	46
4.8.3	Use of Shimafuji Ethernet Board with Main Board	49
4.8.4	Circuit Diagram of Renesas Ethernet Board Y-COMMON-100BASE-TX-LAN8700	50
4.8.5	Circuit Diagram of Renesas Ethernet Board Y-COMMON-100BASE-T1-88Q2112	51
4.9	PSI5/PSI5S Interfaces	52
4.9.1	Circuit Diagram	52
4.9.2	PSI5/PSI5S Interface Connector	52
4.10	eMMC/SFMA Module	53
4.10.1	eMMC/SFMA Interface Connector	53
4.10.2	Extension Board Details	53
4.11	Touch Display	54
4.11.1	Circuit Diagram	54
4.11.2	Enable Touch Display	55
4.11.3	Usage Information	55
4.11.4	Touch Display Connectors	56
4.12	RGB Illuminated Rotary Encoder	57
4.12.1	Circuit Diagram	57
4.13	LED CSI Driver for LED Ring Indicator	58
4.13.1	Circuit Diagram	58
4.14	Interrupt Push Buttons	59
4.14.1	Circuit Diagram	59
4.15	A/D Measurements	60
4.15.1	Circuit Diagram	60
4.15.2	Connector	60
4.16	Signal LEDs	61
4.16.1	Circuit Diagram	61
5.	Precautions	62
5.1	Debugging and Flash Programming Signals	62
5.2	Differences between Mass Production and Prototype Version of the Main Board	62

6.	Mechanical Dimensions.....	63
7.	Schematics.....	64
7.1	Page 1.....	65
7.2	Page 2.....	66
7.3	Page 3.....	67
7.4	Page 4.....	68
7.5	Page 5.....	69
7.6	Page 6.....	70
7.7	Page 7.....	71
7.8	Page 8.....	72
7.9	Page 9.....	73
7.10	Page 10.....	74
7.11	Page 11.....	75
7.12	Page 12.....	76

1. Overview

The RH850/X2X Main Board serves as a simple and easy to use platform for evaluating the features and performance of Renesas Electronics' 32-bit RH850/X2X Main Board microcontrollers. This main board must be used in conjunction with a piggyback board (e.g. Y-RH850-U2A-516PIN-PB-T1-V1), that carries the target RH850/X2X Main Board microcontroller.

Actually we have 2 different versions of the main board, Y-RH850-X2X-MB-T1-V1 and Y-RH850-X2X-MB-T1-V1-JP. The only difference is whether the power supply is included in the delivery or not (refer to *Table 1.1 Package Components for the Y-RH850-X2X-MB-T1-V1*). Thus, we only use the name Y-RH850-X2X-MB-T1-V1 throughout the manual.

Notes

- At the time of release of this manual exist 2 revisions of RH850/X2X Main Board. These revisions are marked by different revision numbers printed on the main board.
 - Prototype board: **D017347_06_V01**
 - Mass production board: **D017347_06_V02**This manual describes the mass production board. Differences are explained in *5.2 Differences between Mass Production and Prototype Version of the Main Board*.
- The document describes the functionality of the main board and guides the user through its operation. For details regarding the operation of the microcontroller, please refer to the device's Hardware User's Manual.
- In this document low active signals are marked by an appended 'Z' to the pin or signal name. E.g., the reset pin is named RESETZ.
- In this document following abbreviations are used:
 - H level, L level: high or low signal level of a digital signal, the absolute voltage value depends on the signal

1.1 Package Components

The Y-RH850-X2X-MB-T1-V1 product package consists of the following items. After you have unpacked the box, check if your Y-RH850-X2X-MB-T1-V1 package contains all of these items. Table 1.1 Package Components for the Y-RH850-X2X-MB-T1-V1 shows all components in the Y-RH850-X2X-MB-T1-V1 package.

Table 1.1 Package Components for the Y-RH850-X2X-MB-T1-V1

Item	Description	Quantity
D016347#01T	RH850/X2X main board	1
D017073	Documentation CD	1
236-000016-05	International power supply unit, 12V/2A	1, not included in Y-RH850-X2X-MB-T1-V1-JP
228-000045-01	USB Cable, Type A to Micro B	1
228-000058-01	Red connection cables	8
228-000059-01	Black connection cables	8
230-000109-01	Parallel Cable [1x DIL connector 10-pin - 1x D-SUB connector 9-pin]	8
230-000110-01	Sub-D male to male gender changer, 9-pin	8
230-000003-01	Jumpers (2-way, 0.1")	280

Note

Please keep the Y-RH850-X2X-MB-T1-V1 packaging at hand for later reuse in sending the product for repair or for other purposes. Always use the original packaging when transporting the Y-RH850-X2X-MB-T1-V1. If packing of your product is not complete, it may be damaged during transportation.

1.2 Applicable Piggyback Boards

For a list of applicable piggyback boards please refer to the "Related products" list via the following link:

[Y-RH850-X2X-MB-T1-V1 Related Products](#)

1.3 Main Features





- User interaction through switches, buttons and LEDs
- 24 LIN interfaces
- 16 CAN interfaces (ready for CAN-FD)
- 2 UART interfaces
- 2 SENT interfaces
- 2 FlexRay interfaces
- 1 PSI5 sensor interface
- 2 connectors for Ethernet modules
- 1 connector for eMMC module
- High density piggyback board connectors
- Display interface
- Single 12V board power supply with onboard voltage regulators
- Operating temperature from 0°C to +40°C

1.4 Extension Boards

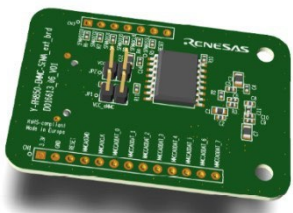
Renesas offers some extension boards for this main board to provide additional functionality.

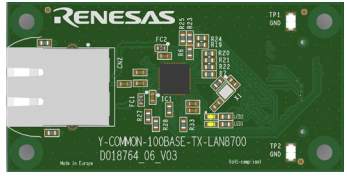
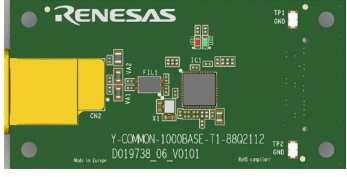
Table 1.2 Extension board overview

Order Code	Description	Board Picture
Y-RH850-TFT-EXT-BRD	TFT display / 2.8" TFT touch shield with capacitive touch	
Y-RH850-EMMC-SFMA-EXT-BRD	eMMC/SFMA extension board	

Order Code	Description	Board Picture
Y-RH850-SENT-EXT-BRD-V2	SENT extension board with IDT ZSSC416x sensor device	 <p>A blue printed circuit board (PCB) with various electronic components. It features a large black integrated circuit (IC) labeled 'IDT ZSSC416x'. Other components include capacitors, resistors, and a potentiometer. The board has several test points and connectors, including a D-sub connector on the left and a circular connector on the right. The Renesas logo and part number 'Y-RH850-SENT-EXT-BRD-V2' are printed on the board.</p>
Y-COMMON-100BASE-TX-LAN8700 (former Y-RH850-100BASE-TX-LAN8700)	Ethernet extension board with LAN8700 100BASE-TX transceiver	 <p>A green PCB with a central integrated circuit labeled 'LAN8700'. The board includes various passive components like capacitors and resistors. It has a D-sub connector on the left and a circular connector on the right. The Renesas logo and part number 'Y-COMMON-100BASE-TX-LAN8700' are visible.</p>
Y-COMMON-1000BASE-T1-88Q2112 (former Y-RH850-1000BASE-T1-88Q2112)	Ethernet extension board with Marvell 88Q2112 1000BASE-T1 transceiver	 <p>A green PCB with a central integrated circuit labeled '88Q2112'. The board features various electronic components and connectors, including a D-sub connector on the left and a circular connector on the right. The Renesas logo and part number 'Y-COMMON-1000BASE-T1-88Q2112' are printed on the board.</p>
Tessera TSE-BRPHY004 (not available anymore)	Ethernet extension board with Broadcom BCM89810	 <p>A green PCB with a central integrated circuit labeled 'BCM89810'. The board includes various components and connectors, such as a D-sub connector on the left and a circular connector on the right. The Tessera logo and part number 'TSE-BRPHY004' are visible.</p>
Tessera TSE-GbPHY004 (not available anymore)	Ethernet extension board with Microchip KSZ9031	 <p>A green PCB with a central integrated circuit labeled 'KSZ9031'. The board features various electronic components and connectors, including a D-sub connector on the left and a circular connector on the right. The Tessera logo and part number 'TSE-GbPHY004' are printed on the board.</p>
Shimafuji ETHER Board	Ethernet extension board with Microchip KSZ8041	 <p>A green PCB with a central integrated circuit labeled 'KSZ8041'. The board includes various components and connectors, such as a D-sub connector on the left and a circular connector on the right. The Shimafuji logo and part number 'ETHER Board' are visible.</p>

1.5 Main Board Views

The following figures provide the top and bottom view of the main board.

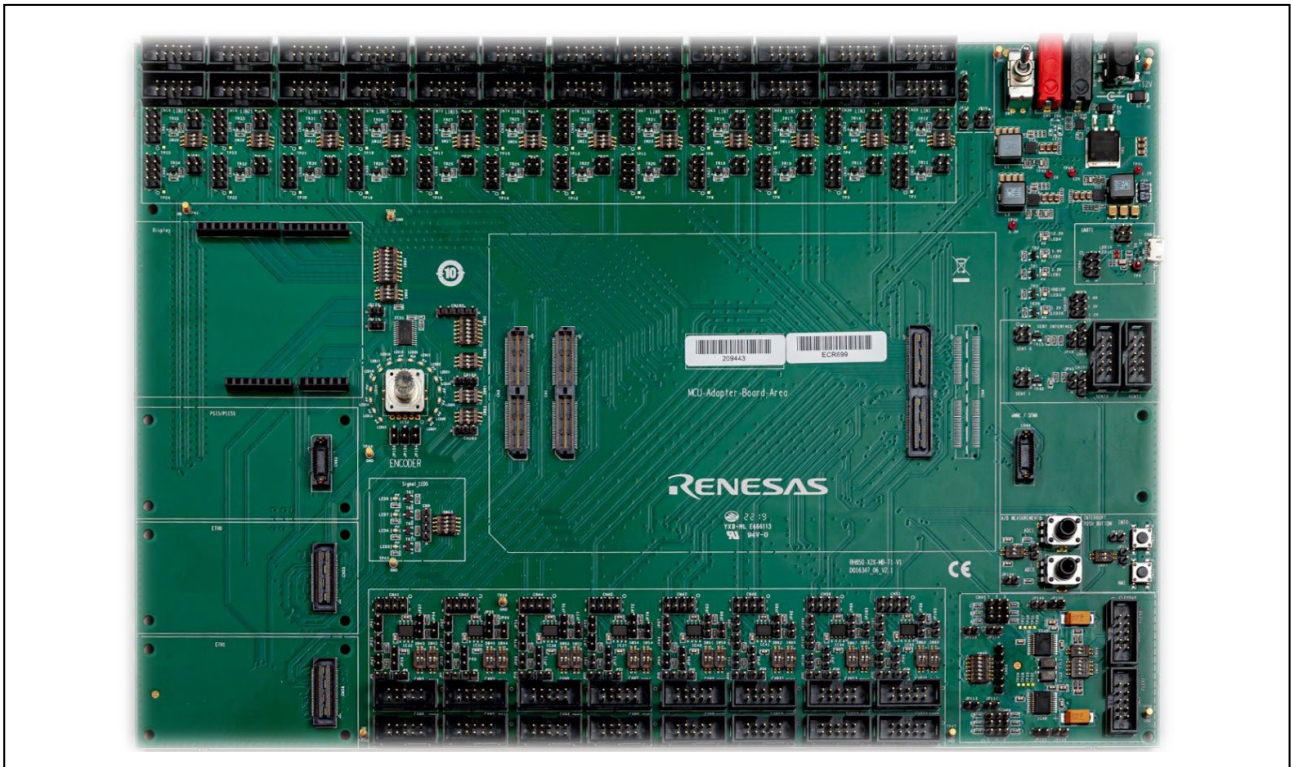

Figure 1.1 Main board top view

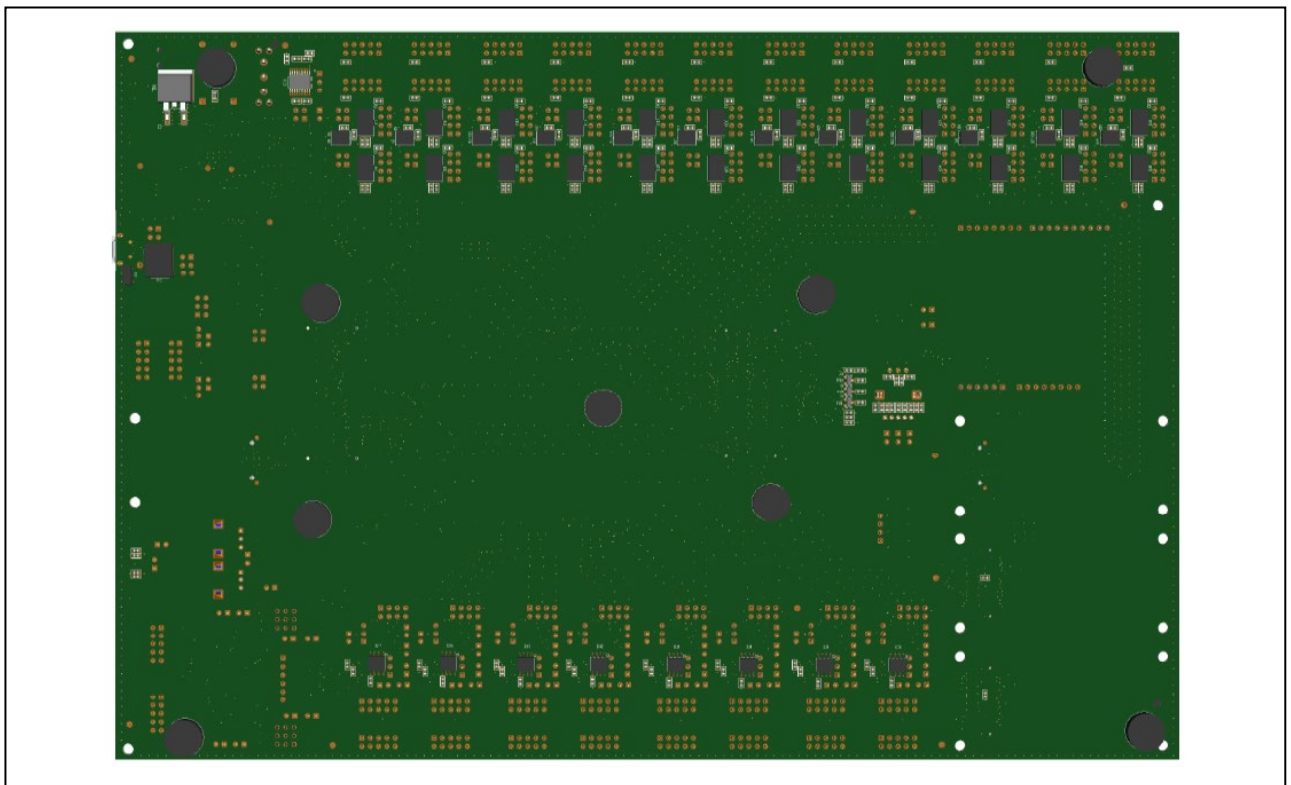

Figure 1.2 Main board bottom view

2.1 Jumpers Overview

The following table provides an overview of all jumpers.

Table 2.1 Jumpers overview

Jumper	Function	Remark
JP1	LIN1 piggyback board signal connections	refer to 4.2 LIN Interfaces
JP2	LIN0 piggyback board signal connections	
JP3	LIN3 piggyback board signal connections	
JP4	LIN2 piggyback board signal connections	
JP5	CAN0 connector pin 3 control	refer to 4.3 CAN Interfaces
JP6	CAN1 connector pin 3 control	
JP7	CAN2 connector pin 3 control	
JP8	CAN3 connector pin 3 control	
JP9	Connector CN14 function (UART0/LIN0) selection	refer to 4.2 LIN Interfaces
JP10	UART0 piggyback board signal connections	refer to 4.6 UART Interfaces
JP11	SENT0 piggyback board signal connections	refer to 4.5 SENT (Single Edge Nibble Transmission) Interfaces
JP12	SENT1 piggyback board signal connections	
JP13	UART1 power supply	refer to 4.6 UART Interfaces
JP14	UART0 power supply	
JP15	CAN4 connector pin 3 control	refer to 4.3 CAN Interfaces
JP16	SENT0 power supply	refer to 4.5 SENT (Single Edge Nibble Transmission) Interfaces
JP17	LIN5 piggyback board signal connections	refer to 4.2 LIN Interfaces
JP18	LIN4 piggyback board signal connections	
JP19	LIN7 piggyback board signal connections	
JP20	LIN6 piggyback board signal connections	
JP21	CAN5 connector pin 3 control	refer to 4.3 CAN Interfaces
JP22	CAN6 connector pin 3 control	
JP23	CAN7 connector pin 3 control	
JP24	CAN11 connector pin 3 control	
JP25	LIN9 piggyback board signal connections	refer to 4.2 LIN Interfaces
JP26	LIN8 piggyback board signal connections	
JP27	LIN11 piggyback board signal connections	
JP28	LIN10 piggyback board signal connections	
JP29	CAN10 connector pin 3 control	refer to 4.3 CAN Interfaces
JP30	CAN8 connector pin 3 control	
JP31	CAN9 connector pin 3 control	
JP32	CAN14 connector pin 3 control	
JP33	LIN13 piggyback board signal connections	refer to 4.2 LIN Interfaces
JP34	LIN12 piggyback board signal connections	
JP35	LIN15 piggyback board signal connections	
JP36	LIN14 piggyback board signal connections	

Table 2.1 Jumpers overview (cont'd)

Jumper	Function	Remark	
JP37	CAN12 connector pin 3 control	refer to 4.3 CAN Interfaces	
JP38	CAN13 connector pin 3 control		
JP39	CAN15 connector pin 3 control		
JP40	SENT1 power supply	refer to 4.5 SENT (Single Edge Nibble Transmission) Interfaces	
JP41	LIN17 piggyback board signal connections	refer to 4.2 LIN Interfaces	
JP42	LIN16 piggyback board signal connections		
JP43	LIN19 piggyback board signal connections		
JP44	LIN18 piggyback board signal connections		
JP49	LIN21 piggyback board signal connections		
JP50	LIN20 piggyback board signal connections		
JP51	LIN23 piggyback board signal connections		
JP52	LIN22 piggyback board signal connections		
JP57	CAN1 STB of CAN PHY		refer to 4.3 CAN Interfaces
JP58	CAN0 STB of CAN PHY		
JP59	CAN3 STB of CAN PHY		
JP60	CAN2 STB of CAN PHY		
JP61	CAN1 VIO of CAN PHY		
JP62	CAN3 VIO of CAN PHY		
JP63	CAN0 VIO of CAN PHY		
JP64	CAN1 PHY power supply		
JP65	CAN2 VIO of CAN PHY		
JP66	CAN3 PHY power supply		
JP67	CAN0 PHY power supply		
JP68	CAN2 PHY power supply		
JP70	CAN5 STB of CAN PHY		
JP71	CAN4 STB of CAN PHY		
JP72	CAN7 STB of CAN PHY		
JP73	CAN6 STB of CAN PHY		
JP74	CAN5 VIO of CAN PHY		
JP75	CAN7 VIO of CAN PHY		
JP76	CAN4 VIO of CAN PHY		
JP77	CAN5 PHY power supply		
JP78	CAN6 VIO of CAN PHY		
JP79	CAN7 PHY power supply		
JP80	CAN4 PHY power supply		
JP81	CAN6 PHY power supply		
JP83	CAN9 STB of CAN PHY		
JP84	CAN8 STB of CAN PHY		
JP85	CAN11 STB of CAN PHY		

Table 2.1 Jumpers overview (cont'd)

Jumper	Function	Remark
JP86	CAN10 STB of CAN PHY	refer to 4.3 CAN Interfaces
JP87	CAN9 VIO of CAN PHY	
JP88	CAN11 VIO of CAN PHY	
JP89	CAN8 VIO of CAN PHY	
JP90	CAN9 PHY power supply	
JP91	CAN10 VIO of CAN PHY	
JP92	CAN11 PHY power supply	
JP93	CAN8 PHY power supply	
JP94	CAN10 PHY power supply	
JP96	CAN13 STB of CAN PHY	
JP97	CAN12 STB of CAN PHY	
JP98	CAN15 STB of CAN PHY	
JP99	CAN14 STB of CAN PHY	
JP100	CAN13 VIO of CAN PHY	
JP101	CAN15 VIO of CAN PHY	
JP102	CAN12 VIO of CAN PHY	
JP103	CAN13 PHY power supply	
JP104	CAN14 VIO of CAN PHY	
JP105	CAN15 PHY power supply	
JP106	CAN12 PHY power supply	
JP107	CAN14 PHY power supply	
JP110	FLEX0 power supply	refer to 4.4 FlexRay Interfaces
JP113	FLEX1 power supply	
JP114	FLEX0 PHY BGE control	
JP117	FLEX1 PHY BGE control	
JP119	Touch-Display power supply V_DISP_5V0 <ul style="list-style-type: none"> JP119[2-1]: V_DISP_5V0 = VCC5V0 JP119[OPEN]: V_DISP_5V0 not connected 	refer to 4.11 Touch Display
JP120	Touch-Display power supply V_DISP_3V3 <ul style="list-style-type: none"> JP120[2-1]: V_DISP_3V3 = VCC3V3 JP120[OPEN]: V_DISP_3V3 not connected 	
JP122	NMI and INT0 interrupts inactive VDD_PUSH signal level <ul style="list-style-type: none"> JP122[2-1]: VDD_PUSH = VDDIOF JP122[OPEN]: VDD_PUSH = GND 	refer to 4.14 Interrupt Push Buttons
JP123	NMI and INT0 signal access	refer to 4.14 Interrupt Push Buttons
JP124	A/D measurement VDD_ADC voltage level <ul style="list-style-type: none"> JP124[2-1]: VDD_ADC = VDDIOF 	refer to 4.15 A/D Measurements
JP149	FLEX0 PHY power supply	refer to 4.4 FlexRay Interfaces
JP150	FLEX0 PHY VBAT supply	
JP151	FLEX1 PHY power supply	

Table 2.1 Jumpers overview (cont'd)

Jumper	Function	Remark
JP152	FLEX1 PHY VBAT supply	refer to 4.4 <i>FlexRay Interfaces</i>
JP154	LED CSI driver power supply	refer to 4.13 <i>LED CSI Driver for LED Ring Indicator</i>
JP155	Encoder IC52 power supply	refer to 4.12 <i>RGB Illuminated Rotary Encoder</i>
JP156	Encoder signal level <ul style="list-style-type: none">JP156[2-1]: Signal level = VDDIOF	

2.2 Switches Overview

The following table provides an overview of all switches.

Table 2.2 Switches overview

Switch	Function	Remark
SW1	Board power supply on/off	refer to 3.3 <i>Board Power Switch</i>
SW5	Signals for LIN0 and LIN1	refer to 4.2 <i>LIN Interfaces</i>
SW6	Signals for LIN2 and LIN3	
SW13	Signals for LIN4 and LIN5	
SW15	Signals for LIN6 and LIN7	
SW20	Signals for LIN8 and LIN9	
SW21	Signals for LIN10 and LIN11	
SW26	Signals for LIN12 and LIN13	
SW27	Signals for LIN14 and LIN15	
SW32	Signals for LIN16 and LIN17	
SW33	Signals for LIN18 and LIN19	
SW38	Signals for LIN20 and LIN21	
SW39	Signals for LIN22 and LIN23	
SW42	CAN0/CAN1 bus termination	refer to 4.3 <i>CAN Interfaces</i>
SW43	Enable signal LED	refer to 4.16 <i>Signal LEDs</i>
SW44	CAN2/CAN3 bus termination	refer to 4.3 <i>CAN Interfaces</i>
SW45	CAN0 <-> CAN1 bus connection	
SW46	CAN2 <-> CAN3 bus connection	
SW48	FlexRay channel0/channel 1 signal connection	refer to 4.4 <i>FlexRay Interfaces</i>
SW50	FlexRay channel 0 bus termination and bus loop	
SW51	CAN4/CAN5 bus termination	refer to 4.3 <i>CAN Interfaces</i>
SW52	NMI push button	refer to 4.14 <i>Interrupt Push Buttons</i>
SW53	INT0 push button	
SW54	CAN6/CAN7 bus termination	refer to 4.3 <i>CAN Interfaces</i>
SW55	CAN4 <-> CAN5 bus connection	
SW56	CAN6 <-> CAN7 bus connection	
SW59	CAN8/CAN9 bus termination	
SW60	CAN10/CAN11 bus termination	
SW61	CAN8 <-> CAN9 bus connection	
SW62	CAN10 <-> CAN11 bus connection	
SW65	CAN12/CAN13 bus termination	
SW66	CAN14/CAN15 bus termination	
SW67	CAN12 <-> CAN13 bus connection	
SW68	CAN14 <-> CAN15 bus connection	
SW69	FlexRay channel 1 bus termination	refer to 4.4 <i>FlexRay Interfaces</i>
SW80	Encoder RGB-LED current measurement	refer to 4.12 <i>RGB Illuminated Rotary Encoder</i>
SW81	Encoder RGB-LED PWM output	

Table 2.2 Switches overview (cont'd)

SW82	LED-Ring CSI interface	refer to 4.13 LED CSI Driver for LED Ring Indicator
SW83	RGB encoder/button signal	refer to 4.12 RGB Illuminated Rotary Encoder
SW84	Touch-Display CSI interface	refer to 4.11 Touch Display
SW86	Touch-Display I2C interface	
SW87	NMI/INT0 interrupt signals	refer to 4.14 Interrupt Push Buttons
SW88	A/D measurements for ADC[0]/ADC[1] enable	refer to 4.15 A/D Measurements

2.3 Connectors Overview

The following table provides an overview of all connectors.

Table 2.3 Connectors overview

Connector	Function	Remark
CN1	Piggyback board connectors	refer to 4.1 <i>Piggyback Board</i>
CN2		
CN3		
CN4	(Not assembled) reserved for future use	
CN5	+12.0 V external power supply	refer to 3.2 <i>Board Power Connection</i>
CN6	USB-connector to FTDI-converter UART1	
CN7	GND for external power supply	
CN8	+12.0 V external power supply	
CN9	LED6-LED9	refer to 4.16 <i>Signal LEDs</i>
CN10	LIN3 voltage selection	refer to 4.2 <i>LIN Interfaces</i>
CN11	LIN0 voltage selection	
CN12	LIN2 voltage selection	
CN13	LIN1 voltage selection	
CN14	LIN0 interface connector	
CN15	SENT0 interface connector	refer to 4.5 <i>SENT (Single Edge Nibble Transmission) Interfaces</i>
CN16	LIN23 interface connector	refer to 4.2 <i>LIN Interfaces</i>
CN17	LIN20 interface connector	
CN18	LIN22 interface connector	
CN19	LIN21 interface connector	
CN20	LIN1 interface connector	
CN21	LIN5 voltage selection	
CN22	LIN4 voltage selection	
CN23	LIN7 voltage selection	
CN24	LIN6 voltage selection	
CN25	LIN2 interface connector	
CN26	LIN9 voltage selection	
CN27	LIN8 voltage selection	
CN28	LIN11 voltage selection	
CN29	LIN10 voltage selection	
CN30	LIN3 interface connector	
CN31	LIN13 voltage selection	
CN32	LIN12 voltage selection	
CN33	LIN15 voltage selection	
CN34	LIN14 voltage selection	
CN35	LIN6 interface connector	
CN36	LIN17 voltage selection	

Table 2.3 Connectors overview (cont'd)

CN37	LIN16 voltage selection	refer to 4.2 LIN Interfaces
CN38	LIN19 voltage selection	
CN39	LIN18 voltage selection	
CN40	LIN21 voltage selection	
CN41	CAN0/1 signal connection	refer to 4.3 CAN Interfaces
CN42	CAN2/3 signal connection	
CN43	CAN1 interface connector	
CN44	CAN4/5 signal connection	
CN45	CAN6/7 signal connection	
CN46	CAN2 interface connector	
CN47	CAN8/9 signal connection	
CN48	CAN10/11 signal connection	
CN49	CAN3 interface connector	
CN50	CAN12/13 signal connection	
CN51	CAN14/15 signal connection	
CN52	CAN4 interface connector	
CN53	FlexRay signal connection	
CN54	FlexRay interface connector channel 0	
CN55	ETH0 Ethernet PHY (MII) connector	refer to 4.8 Ethernet Modules
CN56	ETH1 Ethernet PHY (MII) connector	
CN57	Touch-Display connectors	refer to 4.11 Touch Display
CN58		
CN59		
CN60		
CN61	FlexRay interface connector channel 1	refer to 4.4 FlexRay Interfaces
CN62	PSI5/PSI5S interface	refer to 4.9 PSI5/PSI5S Interfaces
CN63	Voltage levels for A/D measurements on ADC[1:0]	refer to 4.15 A/D Measurements
CN64	LIN4 interface connector	refer to 4.2 LIN Interfaces
CN65	LIN7 interface connector	
CN66	LIN5 interface connector	
CN67	LIN9 interface connector	
CN68	LIN8 interface connector	
CN69	LIN10 interface connector	
CN70	LIN11 interface connector	
CN71	LIN14 interface connector	
CN72	LIN15 interface connector	
CN73	LIN12 interface connector	
CN74	LIN13 interface connector	
CN75	LIN18 interface connector	
CN76	LIN16 interface connector	

Table 2.3 Connectors overview (cont'd)

CN77	LIN19 interface connector	refer to 4.2 LIN Interfaces
CN78	LIN17 interface connector	
CN79	LIN20 voltage selection	
CN80	LIN23 voltage selection	
CN81	LIN22 voltage selection	
CN82	CAN0 interface connector	refer to 4.3 CAN Interfaces
CN83	CAN5 interface connector	
CN84	CAN6 interface connector	
CN85	CAN7 interface connector	
CN86	CAN11 interface connector	
CN87	CAN10 interface connector	
CN88	CAN8 interface connector	
CN89	CAN9 interface connector	
CN90	CAN14 interface connector	
CN91	CAN12 interface connector	
CN92	CAN13 interface connector	
CN93	CAN15 interface connector	
CN94	USB/UART1 signals	
CN95	FlexRay channel 0 setup	refer to 4.4 FlexRay Interfaces
CN96	FlexRay channel 1 setup	
CN97	On-board voltage connector VDDIOF selection	refer to 3.2 Board Power Connection
CN98	eMMC/SFMA interface connector	refer to 4.10 eMMC/SFMA Module
CN99	SENT0 bus power or programming power supply	refer to 4.5 SENT (Single Edge Nibble Transmission) Interfaces
CN100	SENT1 interface	
CN101	SENT1 bus power or programming power supply	
CN102	LED CSI interface	refer to 4.13 LED CSI Driver for LED Ring Indicator
CN103	Rotary encoder position input signals	refer to 4.12 RGB Illuminated Rotary Encoder
CN104	RGB PWM input signals	

2.4 LEDs Overview

The following table provides an overview of all LEDs.

Table 2.4 LEDs overview

LED	Function	Color	Remark
LED1	3.3 V power supply VCC3V3	blue	refer to 3.6 <i>Voltage Level LEDs</i>
LED2	5.0 V power supply VCC5V0		
LED3	3.3 V or 5.0 V power supply VDDIOF		
LED4	12.0 V external power supply VCC12V0		
LED6	Signal LED	blue	refer to 4.16 <i>Signal LEDs</i>
LED7	Signal LED		
LED8	Signal LED		
LED9	Signal LED		
LED10	USB send/receive data	red	refer to 4.6 <i>UART Interfaces</i>
LED11			
LED12-LED27	Encoder switch ring LEDs	blue	refer to 4.13 <i>LED CSI Driver for LED Ring Indicator</i>
LED28	1.2 V power supply VCC1V2	blue	refer to 3.6 <i>Voltage Level LEDs</i>

3.2 Board Power Connection

The Board is operated with a single external 12 V power supply via two banana-type plugs:

- CN5: red for typ. +12V (allowed range: 9.5V – 15.0V)
- CN7: black for GND

Alternatively, the board provides a barrel connector for DC power supply (CN8, ).

All other supply voltages for the main and the piggyback board are generated on the main board by voltage regulators. All on-board generated voltages are connected to the pin header CN97 for measurement purposes.

Table 3.1 Supply voltages pin header CN97

Pin	Voltage
1	VCC1V2
3	VCC3V3
5	VCC5V0

Pin	Voltage
2	VDDIOF
4	
6	

Note

Within this document all voltage values are considered as 'typical'.

Please refer to the 'Electrical Characteristics' section of the Hardware User's Manual for allowed voltage ranges.

3.3 Board Power Switch

The entire board power supply can be switched on or off via the switch SW1. If SW1 is tilted to the edge of the board, the power supply is switched off.

3.4 VDDIOF Selection

The VDDIOF voltage is used as the input/output voltage from the piggyback board via the connectors CN1 to CN3.

The correct VDDIOF voltage level is determined by the piggyback board. The piggyback board delivers VDDIOF to the main board.

Typical levels for VDDIOF are 3.3 V or 5 V.

3.5 Reverse Voltage Connection Protection

The Board is protected against reverse connection of the external power supply via CN5, CN7 or CN8.

3.6 Voltage Level LEDs

The following blue LEDs indicate the presence of various voltages on the main board:

- LED1 for 3.3 V power rail VCC3V3
- LED2 for 5.0 V power rail VCC5V0
- LED3 for 3.3 V or 5.0 V power rail VDDIOF
- LED4 for 12.0 V external power supply VCC12V0
- LED28 for 1.2 V power rail VCC1V2

4. Peripheral Circuits

The main board includes circuits for output from the processor peripheral modules (e.g., CAN, LIN, FlexRay, Ethernet) or interfaces to external modules (e.g. touch screen, eMMC). All circuits can be controlled by the processor on the piggyback board via connectors CN1-CN3.

4.1 Piggyback Board

The main board has 3 connectors CN1-CN3 for connecting piggyback boards with different microcontrollers to this main board.

Regarding the function on the piggyback board, please refer to the User's Manual of the selected piggyback board.

Please refer to *1.2 Applicable Piggyback Boards* for a list of supported boards.

4.1.1 Piggyback Board Connectors

The signals of each connector are summarized in the following tables.

Table 4.1 Piggyback Board Connector CN1 pin assignment

Pin	Main board function	Pin	Main board function
1	VCC5V0	2	VCC5V0
3	VCC5V0	4	VCC5V0
5	RESET	6	NMI
7	WAKE	8	–
9	INT0	10	INT1
11	INT2	12	INT3
13	–	14	–
15	UART0TX	16	UART1TX
17	UART0RX	18	UART1RX
19	LIN0TX	20	LIN1TX
21	LIN0RX	22	LIN1RX
23	IIC0SCL	24	IIC1SCL
25	IIC0SDA	26	IIC1SDA
27	CAN0TX	28	CAN1TX
29	CAN0RX	30	CAN1RX
31	SENT0RX	32	SENT1RX
33	SENT0SPCO	34	SENT1SPCO
35	PSI5SRX0	36	PSI5RX0
37	PSI5STX0	38	PSI5TX0
39	PSI5SCLK0	40	–
41	FLX0TX	42	FLX0EN
43	FLX0RX	44	FLXSTPWT
45	FLX1TX	46	FLX1EN
47	FLX1RX	48	FLXCLK
49	–	50	–
51	ETH0MDIO	52	ETH0MDC
53	ETH0RXD0	54	EH0TXD0

Table 4.1 Piggyback Board Connector CN1 pin assignment

Pin	Main board function	Pin	Main board function
55	ETH0RXD1	56	EH0TXD1
57	ETH0RXD2	58	EH0TXD2
59	ETH0RXD3	60	EH0TXD3
61	ETH0RXCLK	62	ETH0TXCLK
63	ETH0RXER	64	ETH0TXER
65	ETH0CRSDV	66	ETH0TXEN
67	ETH0RXDV	68	ETH0COL
69	ETH0RESET	70	ETH0LINK
71	–	72	–
73	USB0UDMF	74	USB0UDMH
75	USB0UDPF	76	USB0UDPH
77	–	78	–
79	–	80	–
81	–	82	–
83	–	84	–
85	DIGIO_0	86	DIGIO_1
87	DIGIO_2	88	DIGIO_3
89	DIGIO_4	90	DIGIO_5
91	DIGIO_6	92	DIGIO_7
93	DIGIO_8	94	DIGIO_9
95	DIGIO_10	96	DIGIO_11
97	DIGIO_12	98	DIGIO_13
99	DIGIO_14	100	DIGIO_15
101	–	102	–
103	MUX0	104	MUX1
105	MUX2	106	–
107	ADC0	108	ADC1
109	ADC2	110	ADC3
111	ADC4	112	ADC5
113	ADC6	114	ADC7
115	VDDIOF	116	VDDIOF
117	VCC3V3	118	VCC3V3
119	VCC3V3	120	VCC3V3
121	Common Shield GND	122	Common Shield GND
123	Common Shield GND	124	Common Shield GND
125	Common Shield GND	126	Common Shield GND
127	Common Shield GND	128	Common Shield GND

Table 4.2 Piggyback Board Connector CN2 pin assignment

Pin	Main board function	Pin	Main board function
1	CAN2TX	2	CAN3TX
3	CAN2RX	4	CAN3RX
5	CAN4TX	6	CAN5TX
7	CAN4RX	8	CAN5RX
9	LIN2TX	10	LIN3TX
11	LIN2RX	12	LIN3RX
13	LIN4TX	14	LIN5TX
15	LIN4RX	16	LIN5RX
17	LIN6TX	18	LIN7TX
19	LIN6RX	20	LIN7RX
21	LIN8TX	22	LIN9TX
23	LIN8RX	24	LIN9RX
25	LIN10TX	26	LIN11TX
27	LIN10RX	28	LIN11RX
29	LIN12TX	30	LIN13TX
31	LIN12RX	32	LIN13RX
33	LIN14TX	34	LIN15TX
35	LIN14RX	36	LIN15RX
37	–	38	–
39	CAN12TX	40	CAN13TX
41	CAN12RX	42	CAN13RX
43	CAN14TX	44	CAN15TX
45	CAN14RX	46	CAN15RX
47	CAN6TX	48	CAN7TX
49	CAN6RX	50	CAN7RX
51	CAN8TX	52	CAN9TX
53	CAN8RX	54	CAN9RX
55	CAN10TX	56	CAN11TX
57	CAN10RX	58	CAN11RX
59	–	60	–
61	LIN16TX	62	LIN17TX
63	LIN16RX	64	LIN17RX
65	LIN18TX	66	LIN19TX
67	LIN18RX	68	LIN19RX
69	LIN20TX	70	LIN21TX
71	LIN20RX	72	LIN21RX
73	LIN22TX	74	LIN23TX
75	LIN22RX	76	LIN23RX
77	–	78	–
79	SFMA0CLK	80	SFMA0SSL

Table 4.2 Piggyback Board Connector CN2 pin assignment

Pin	Main board function	Pin	Main board function
81	SFMA0IO0	82	SFMA0IO1
83	SFMA0IO2	84	SFMA0IO3
85	–	86	–
87	MMCA0CLK	88	MMCA0CMD
89	MMCA0DAT0	90	MMCA0DAT1
91	MMCA0DAT2	92	MMCA0DAT3
93	MMCA0DAT4	94	MMCA0DAT5
95	MMCA0DAT6	96	MMCA0DAT7
97	–	98	–
99	ETH1MDIO	100	ETH1MDC
101	ETH1RXD0	102	ETH1TXD0
103	ETH1RXD1	104	ETH1TXD1
105	ETH1RXD2	106	ETH1TXD2
107	ETH1RXD3	108	ETH1TXD3
109	ETH1RXCLK	110	ETH1TXCLK
111	ETH1RXER	112	ETH1TXER
113	ETH1CRSDV	114	ETH1TXEN
115	ETH1RXDV	116	ETH1COL
117	ETH1RESET	118	ETH1LINK
119	–	120	–
121	Common Shield GND	122	Common Shield GND
123	Common Shield GND	124	Common Shield GND
125	Common Shield GND	126	Common Shield GND
127	Common Shield GND	127	Common Shield GND

Table 4.3 Piggyback Board Connector CN3 pin assignment

Pin	Main board function	Pin	Main board function
1	CSI0CS0	2	CSI0CLK
3	CSI0CS1	4	CSI0SI
5	CSI0CS2	6	CSI0SO
7	CSI0CS3	8	–
9	–	10	CSI1CS1
11	–	12	–
13	PSI5SRX1	14	PSI5RX1
15	PSI5STX1	16	PSI5TX1
17	PSI5SCLK1	18	–
19	–	20	–
21	CSI1CS2	22	CSI1CS3
23	–	24	CSI1CS0
25	–	26	DIGIO_24
27	–	28	CSI1SO
29	CSI1SCLK	30	CSI1SI
31	–	32	–
33	–	34	–
35	–	36	–
37	–	38	–
39	–	40	–
41	–	42	–
43	–	44	–
45	–	46	–
47	–	48	–
49	–	50	–
51	–	52	–
53	–	54	–
55	AD1_0	56	AD1_1
57	AD1_2	58	AD1_3
59	AD1_4	60	AD1_5
61	AD1_6	62	AD1_7
63	PWM0	64	PWM1
65	PWM2	66	PWM3
67	PWM4	68	PWM5
69	PWM6	70	PWM7
71	DIGIO_16	72	DIGIO_17
73	DIGIO_18	74	DIGIO_19
75	DIGIO_20	76	DIGIO_21
77	DIGIO_22	78	DIGIO_23
79	ENC0	80	ENC1

Table 4.3 Piggyback Board Connector CN3 pin assignment

Pin	Main board function	Pin	Main board function
81	–	82	–
83	–	84	–
85	–	86	–
87	–	88	–
89	–	90	–
91	–	92	–
93	–	94	–
95	–	96	–
97	–	98	–
99	–	100	ETH0_SO_P
101	–	102	ETH0_SO_N
103	–	104	–
105	–	106	ETH0_SI_P
107	–	108	ETH0_SI_N
109	–	110	–
111	–	112	ETH1_SO_P
113	–	114	ETH1_SO_N
115	–	116	–
117	–	118	ETH1_SI_P
119	–	120	ETH1_SI_N
121	Common Shield GND	122	Common Shield GND
123	Common Shield GND	124	Common Shield GND
125	Common Shield GND	126	Common Shield GND
127	Common Shield GND	128	Common Shield GND

4.2 LIN Interfaces

The main board provides 24 LIN interfaces using NXP TJA1021 LIN transceiver.

Power supply for each channel can be controlled separately via DIP switches.

4.2.1 Circuit Diagram

Below circuit diagram shows the circuitry for LIN0 and LIN1. The other LIN interfaces use a similar circuit.

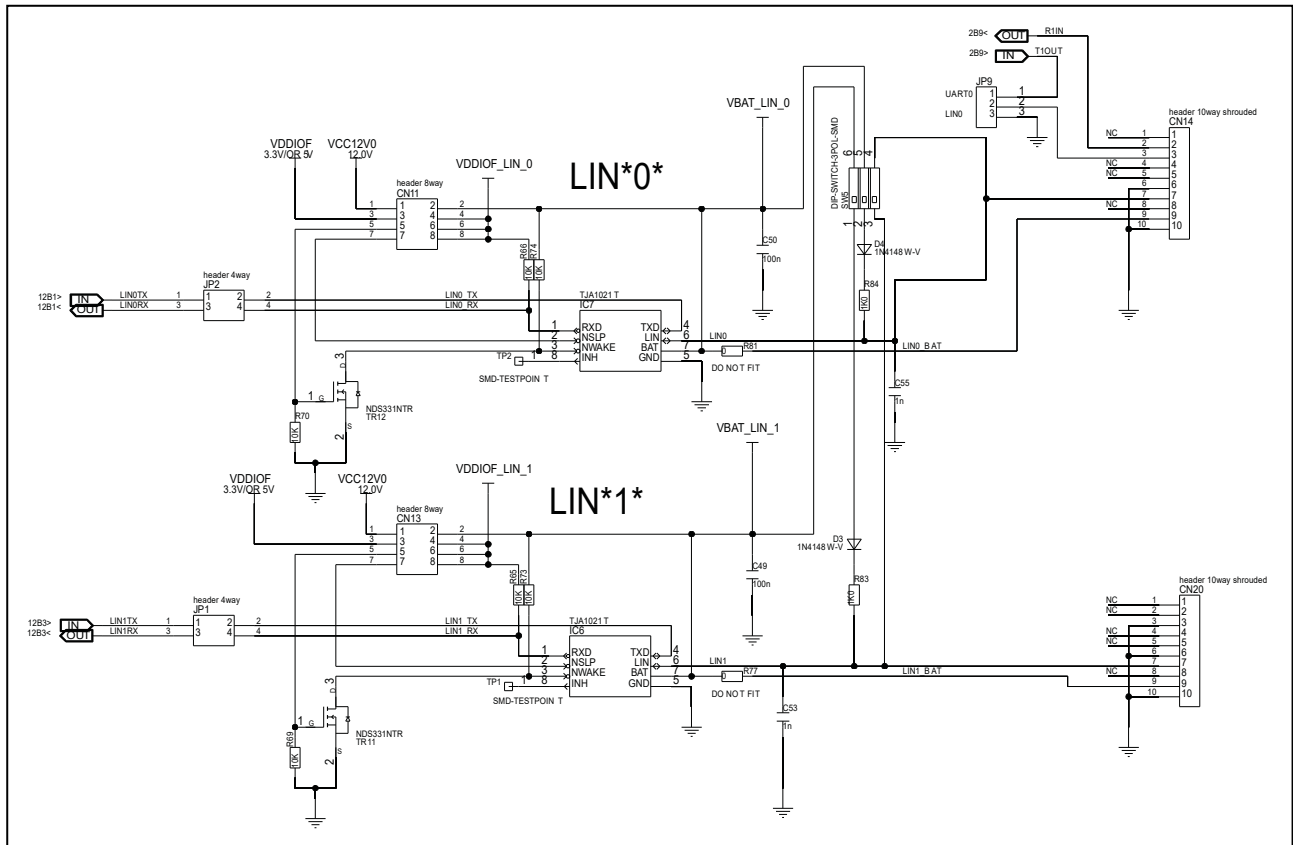

Figure 4.1 LIN interface circuit diagram

4.2.2 Connector Sharing

The connector CN14 can be used as LIN0 or UART0 interface:

- JP9[2-1]:CN14 is used as UART0 connector
- JP9[2-3]:CN14 is used as LIN0 connector

4.2.3 Power Supply Selection

Power supply for each LIN channel is controlled by DIP switches.

Table 4.4 Power supply switches for LIN channels

Switch	LIN interface	Switch	LIN interface	Switch	LIN interface
SW5[1]	LIN1	SW20[1]	LIN9	SW32[1]	LIN17
SW5[2]	LIN0	SW20[2]	LIN8	SW32[2]	LIN16
SW6[1]	LIN3	SW21[1]	LIN11	SW33[1]	LIN19
SW6[2]	LIN2	SW21[2]	LIN10	SW33[2]	LIN18
SW13[1]	LIN5	SW26[1]	LIN13	SW38[1]	LIN21
SW13[2]	LIN4	SW26[2]	LIN12	SW38[2]	LIN20
SW15[1]	LIN7	SW27[1]	LIN15	SW39[1]	LIN23
SW15[2]	LIN6	SW27[2]	LIN14	SW39[2]	LIN22

With the voltage selection pin headers CNm the following functions can be controlled for each LINn circuit:

Table 4.5 LINn circuit voltage selection pin headers CNm

Pin	Voltage	Pin	Voltage
1	VCC12V0	2	VBAT_LIN_n
3	Connect global VDDIOF to VDDIOF_LIN_n	4	VDDIOF_LIN_n
5	Set LINn transceiver NWAKE to GND	6	
7	Set LINn transceiver NSLP to VDDIOF_LIN_n	8	

Table 4.6 LINn and voltage selection pin headers CNm correspondence

LINn	CNm	LINn	CNm	LINn	CNm	LINn	CNm
LIN0	CN11	LIN6	CN24	LIN12	CN32	LIN18	CN39
LIN1	CN13	LIN7	CN23	LIN13	CN31	LIN19	CN38
LIN2	CN12	LIN8	CN27	LIN14	CN34	LIN20	CN79
LIN3	CN10	LIN9	CN26	LIN15	CN33	LIN21	CN40
LIN4	CN22	LIN10	CN29	LIN16	CN37	LIN22	CN81
LIN5	CN21	LIN11	CN28	LIN17	CN36	LIN23	CN80

4.2.4 LIN Signals Piggyback Board Connection

The LIN signals from the microcontroller on the piggyback board can be connected to the LIN circuitry on the main board using the following jumpers:

Table 4.7 LIN signals connection jumpers

LINn	JP	LINn	JP	LINn	JP	LINn	JP
LIN0	JP2	LIN6	JP20	LIN12	JP34	LIN18	JP44
LIN1	JP1	LIN7	JP19	LIN13	JP33	LIN19	JP43
LIN2	JP4	LIN8	JP26	LIN14	JP36	LIN20	JP50
LIN3	JP3	LIN9	JP25	LIN15	JP35	LIN21	JP49
LIN4	JP18	LIN10	JP28	LIN16	JP42	LIN22	JP52
LIN5	JP17	LIN11	JP27	LIN17	JP41	LIN23	JP51

4.2.5 LIN Bus Loopback

The LIN DIP switches have one switch for every 2 LIN channels which allow the connection of these LIN interfaces.

Table 4.8 Bus connections for LIN channels

Switch	Bus connection	Switch	Bus connection
SW5[3]	Connection LIN0 <-> LIN1	SW26[3]	Connection LIN12 <-> LIN13
SW6[3]	Connection LIN2 <-> LIN3	SW27[3]	Connection LIN14 <-> LIN15
SW13[3]	Connection LIN4 <-> LIN5	SW32[3]	Connection LIN16 <-> LIN17
SW15[3]	Connection LIN6 <-> LIN7	SW33[3]	Connection LIN18 <-> LIN19
SW20[3]	Connection LIN8 <-> LIN9	SW38[3]	Connection LIN20 <-> LIN21
SW21[3]	Connection LIN10 <-> LIN11	SW39[3]	Connection LIN22 <-> LIN23

4.2.6 LIN Interface Connectors

Table 4.9 LIN interface LINn and 10-pin connector CNm correspondence

LINn	CNm	LINn	CNm	LINn	CNm	LINn	CNm
LIN0	CN14	LIN6	CN35	LIN12	CN73	LIN18	CN75
LIN1	CN20	LIN7	CN65	LIN13	CN74	LIN19	CN77
LIN2	CN25	LIN8	CN68	LIN14	CN71	LIN20	CN17
LIN3	CN30	LIN9	CN67	LIN15	CN72	LIN21	CN19
LIN4	CN64	LIN10	CN69	LIN16	CN76	LIN22	CN18
LIN5	CN66	LIN11	CN70	LIN17	CN78	LIN23	CN16

Table 4.10 LINn interface on 10-pin connectors CNm

CN14 for LIN0 (UART0*)			CNm (LINn) (see table below)	
Pin	Function in LIN0 mode (JP9[2-3])	Function in UART00 mode (JP9[2-1])	Pin	Function
1	–	–	1	–
2	(R1IN*)	R1IN	2	–
3	GND	T1OUT	3	GND
4	–	–	4	–
5	–	–	5	–
6	GND	GND	6	GND
7	LINn	(LINn*)	7	LINn
8	–	–	8	–
9	LINn_BAT	(LINn_BAT*)	9	LINn_BAT
10	GND	GND	10	GND

Note: * These signals are always connected to the related pin but may be irrelevant in the respective mode.

4.3 CAN Interfaces

The main board provides 16 CAN interfaces using Microchip ATA6561 CAN transceiver.

4.3.1 Circuit Diagram

Below circuit diagram shows the circuitry for CAN0 and CAN1. The other CAN channels use a similar circuitry.

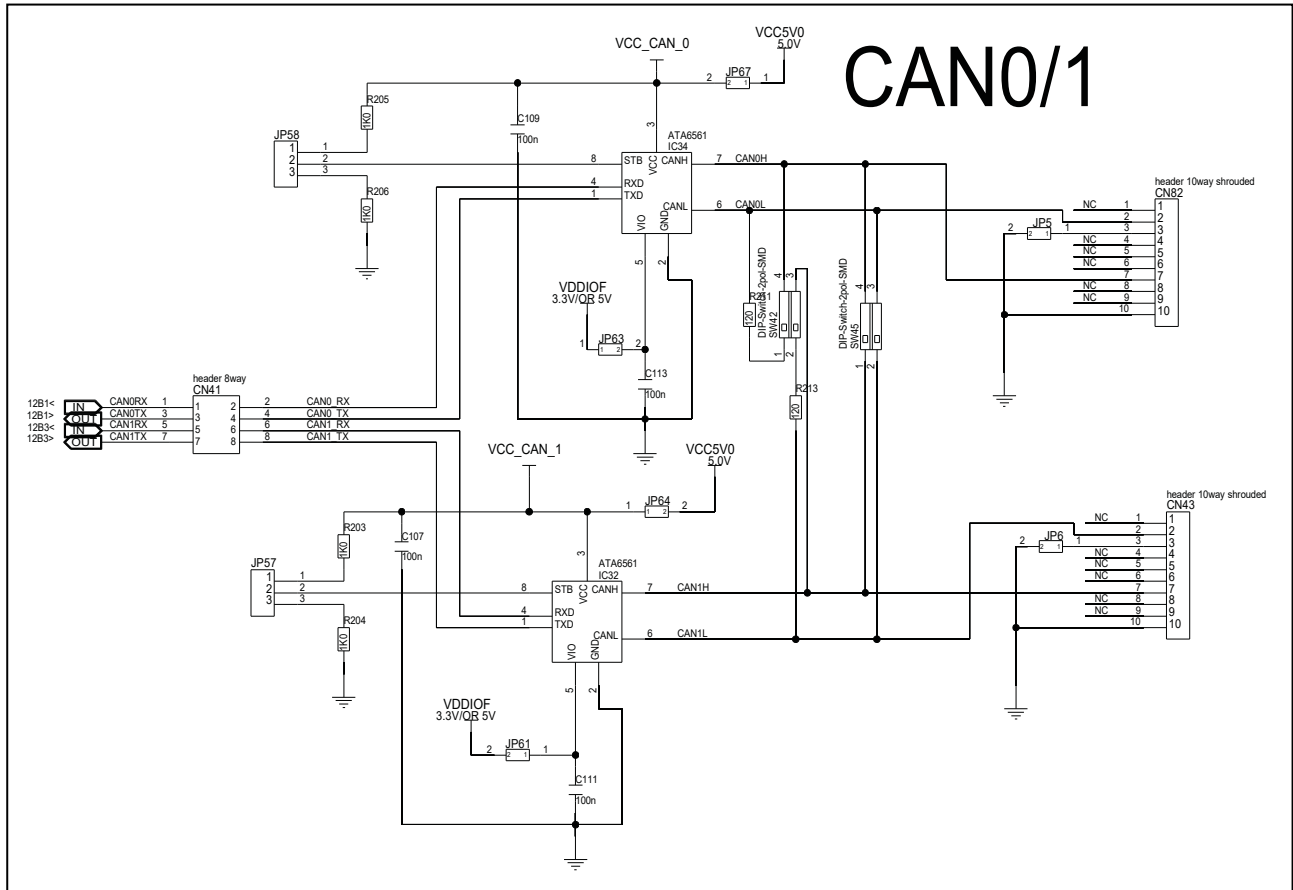

Figure 4.2 CAN interface circuit diagram

The CAN signals from the microcontroller on the piggyback board can be connected to the CAN circuitry on the main board using the following jumpers:

Table 4.11 CAN signals connection jumpers

CAN	CNm	CANn	CNm	CANn	CNm	CANn	CNm
CAN0_RX	CN41[1-2]	CAN4_RX	CN44[1-2]	CAN8_RX	CN47[1-2]	CAN12_RX	CN50[1-2]
CAN0_TX	CN41[3-4]	CAN4_TX	CN44[3-4]	CAN8_TX	CN47[3-4]	CAN12_TX	CN50[3-4]
CAN1_RX	CN41[5-6]	CAN5_RX	CN44[5-6]	CAN9_RX	CN47[5-6]	CAN13_RX	CN50[5-6]
CAN1_TX	CN41[7-8]	CAN5_TX	CN44[7-8]	CAN9_TX	CN47[7-8]	CAN13_TX	CN50[7-8]
CAN2_RX	CN42[1-2]	CAN6_RX	CN45[1-2]	CAN10_RX	CN48[1-2]	CAN14_RX	CN51[1-2]
CAN2_TX	CN42[3-4]	CAN6_TX	CN45[3-4]	CAN10_TX	CN48[3-4]	CAN14_TX	CN51[3-4]
CAN3_RX	CN42[5-6]	CAN7_RX	CN45[5-6]	CAN11_RX	CN48[5-6]	CAN15_RX	CN51[5-6]
CAN3_TX	CN42[7-8]	CAN7_TX	CN45[7-8]	CAN11_TX	CN48[7-8]	CAN15_TX	CN51[7-8]

4.3.2 Power Supply

With the voltage connection pin headers JPy and JPx the power supply and the VIO supply can be connected to each CANn circuit:

Table 4.12 CANn power supply VCC_CAN_n and VIO jumper connection correspondence

CANn	JPy	JPx	CANn	JPy	JPx	CANn	JPy	JPx	CANn	JPy	JPx
CAN0	JP67	JP63	CAN4	JP80	JP76	CAN8	JP93	JP89	CAN12	JP106	JP102
CAN1	JP64	JP61	CAN5	JP77	JP74	CAN9	JP90	JP87	CAN13	JP103	JP100
CAN2	JP68	JP65	CAN6	JP81	JP78	CAN10	JP94	JP91	CAN14	JP107	JP104
CAN3	JP66	JP62	CAN7	JP79	JP75	CAN11	JP92	JP88	CAN15	JP105	JP101

4.3.3 CAN Bus Termination

Every CAN interface has one switch to enable bus termination.

Table 4.13 CAN connector pin assignment

Switch	Bus termination	Switch	Bus termination
SW42[1]	CAN0 bus termination	SW59[1]	CAN8 bus termination
SW42[2]	CAN1 bus termination	SW59[2]	CAN9 bus termination
SW44[1]	CAN2 bus termination	SW60[1]	CAN10 bus termination
SW44[2]	CAN3 bus termination	SW60[2]	CAN11 bus termination
SW51[1]	CAN4 bus termination	SW65[1]	CAN12 bus termination
SW51[2]	CAN5 bus termination	SW65[2]	CAN13 bus termination
SW54[1]	CAN6 bus termination	SW66[1]	CAN14 bus termination
SW54[2]	CAN7 bus termination	SW66[2]	CAN15 bus termination

4.3.4 CAN Bus Loopback

Like LIN interfaces also CAN interfaces have DIP switches to connect 2 neighboring buses. Due to the physical bus interface always 2 DIP switches are used to connect 2 buses.

Table 4.14 Bus connections for LIN channels

Switch	Bus connection	Switch	Bus connection
SW45[1]	CAN0H <-> CAN1H	SW61[1]	CAN8H <-> CAN9H
SW45[2]	CAN0L <-> CAN1L	SW61[2]	CAN8L <-> CAN9L
SW46[1]	CAN2H <-> CAN3H	SW62[1]	CAN10H <-> CAN11H
SW46[2]	CAN2L <-> CAN3L	SW62[2]	CAN10L <-> CAN11L
SW55[1]	CAN4H <-> CAN5H	SW67[1]	CAN12H <-> CAN13H
SW55[2]	CAN4L <-> CAN5L	SW67[2]	CAN12L <-> CAN13L
SW56[1]	CAN6H <-> CAN7H	SW68[1]	CAN14H <-> CAN15H
SW56[2]	CAN6L <-> CAN7L	SW68[2]	CAN14L <-> CAN15L

4.3.5 CANn STB Control

The jumper JPx can be used to set the level of each CANn STB input pin:

- JPx[2-1]:STBn is pulled up to high level.
- JPx[2-3]:STBn is pulled down to low level.

Table 4.15 CANn STB signal control jumpers

CANn	JPx
CAN0	JP58
CAN1	JP57
CAN2	JP60
CAN3	JP59

CANn	JPx
CAN4	JP71
CAN5	JP70
CAN6	JP73
CAN7	JP72

CANn	JPx
CAN8	JP84
CAN9	JP83
CAN10	JP86
CAN11	JP85

CANn	JPx
CAN12	JP97
CAN13	JP96
CAN14	JP99
CAN15	JP98

4.3.6 CAN Interface Connectors

Table 4.16 CAN connector pin assignment

Pin	Voltage
1	–
2	CANnL
3	–/GND*
4	–
5	–

Pin	Voltage
6	–
7	CANnH
8	–
9	–
10	GND

Note: * Depends on jumper JPk setting:
 – JPk open: – (i.e. not connected)
 – JPk closed: GND

Table 4.17 CAN interface CANn and connector CNm correspondence

CANn	CNm	JPk
CAN0	CN82	JP5
CAN1	CN43	JP6
CAN2	CN46	JP7
CAN3	CN49	JP8

CANn	CNm	JPk
CAN4	CN52	JP15
CAN5	CN83	JP21
CAN6	CN84	JP22
CAN7	CN85	JP23

CANn	CNm	JPk
CAN8	CN88	JP30
CAN9	CN89	JP31
CAN10	CN87	JP29
CAN11	CN86	JP24

CANn	CNm	JPk
CAN12	CN91	JP37
CAN13	CN92	JP38
CAN14	CN90	JP32
CAN15	CN93	JP39

4.4 FlexRay Interfaces

The main board provides 2 FlexRay interfaces using NXP TJA1080ATS FlexRay transceiver.

4.4.1 Circuit Diagram

Below circuit diagram shows the circuitry for FLEX0 and FLEX1.

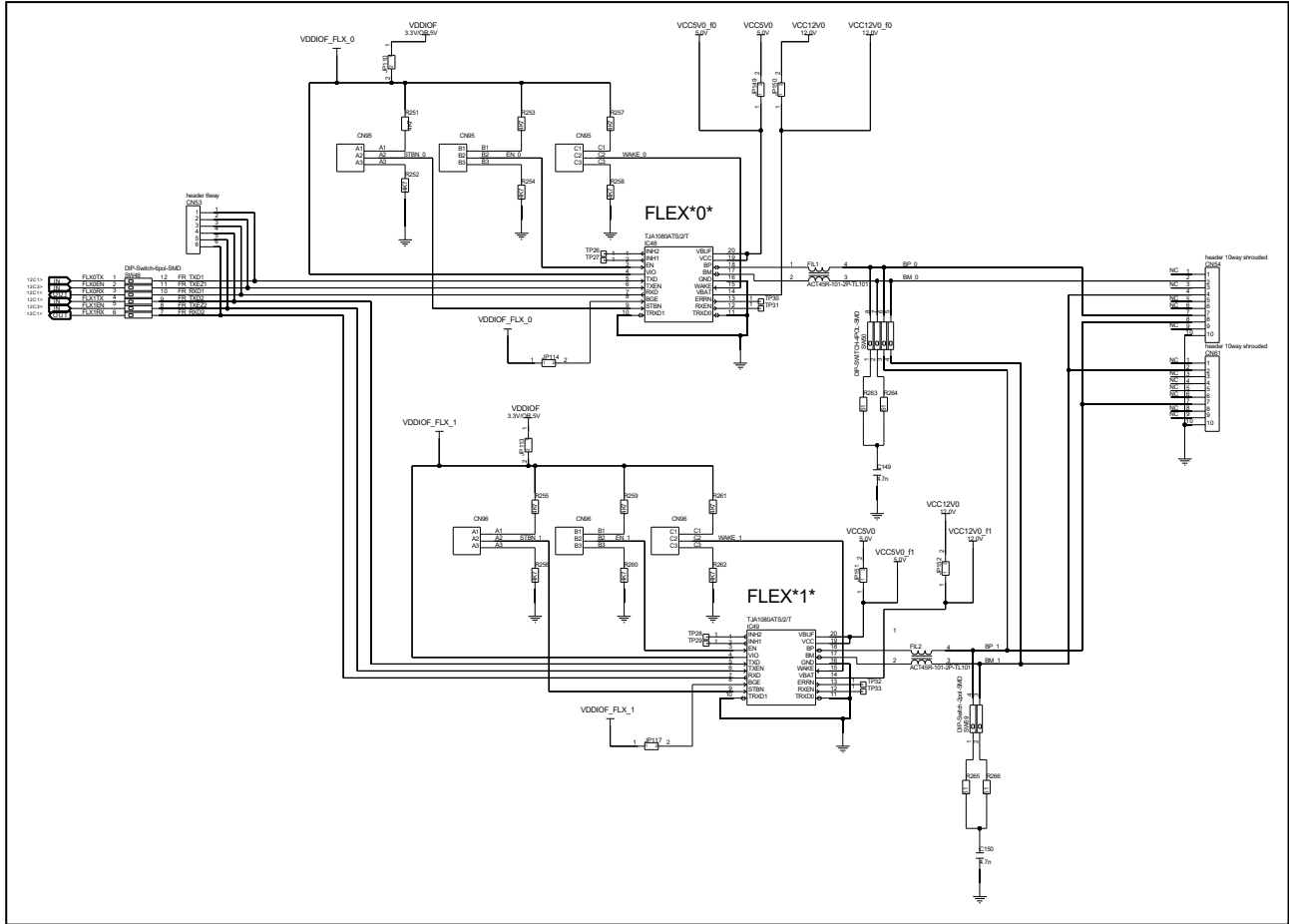

Figure 4.3 FlexRay interface circuit diagram

4.4.2 Signal Connections

The FlexRay signals from the microcontroller on the piggyback board can be connected to the FlexRay circuitry on the main board using DIP-switch SW48.

Table 4.18 FlexRay connections on DIP-switch SW48

SW48	Function	Monitor connection
SW48[1]	Connect Tx signal to FlexRay0	CN53[1]
SW48[2]	Connect enable signal to FlexRay0	CN53[2]
SW48[3]	Connect Rx signal to FlexRay0	CN53[3]
SW48[4]	Connect Tx signal to FlexRay1	CN53[4]
SW48[5]	Connect enable signal to FlexRay1	CN53[5]
SW48[6]	Connect Rx signal to FlexRay1	CN53[6]

4.4.3 Power Supply

The FlexRay circuitry’s power supplies can be connected using the following jumpers:

Table 4.19 FlexRay power supply jumpers

FlexRay0	JPx
VCC/VBUF	JP149
VBAT	JP150
VIO	JP110

FlexRay1	JPx
VCC/VBUF	JP151
VBAT	JP152
VIO	JP113

4.4.4 Control Signals

The FlexRay transceiver status control signals can be controlled with the following jumpers:

Table 4.20 FlexRay transceiver status control signal jumpers

FlexRay0	
EN	CN95B[1-2]: VDDIOF_FLX_0 CN95B[2-3]: GND
WAKE	CN95C[1-2]: VDDIOF_FLX_0 CN95C[2-3]: GND
STBN	CN95A[1-2]: VDDIOF_FLX_0 CN95A[2-3]: GND
BGE	JP114

FlexRay1	
EN	CN96B[1-2]: VDDIOF_FLX_1 CN96B[2-3]: GND
WAKE	CN96C[1-2]: VDDIOF_FLX_1 CN96C[2-3]: GND
STBN	CN96A[1-2]: VDDIOF_FLX_1 CN96A[2-3]: GND
BGE	JP117

Switches SW50 and SW99 control bus termination. In addition, 2 switches on SW50 can also be used to create a loop connection between FlexRay0 and FlexRay1 channel.

Table 4.21 FlexRay Bus 0 termination and loop control

SW50	
SW50[1]	BUS0 termination: BP_0
SW50[2]	BUS0 termination: BM_0
SW50[3]	Connect BP_1 to BP_0
SW50[4]	Connect BM_1 to BM_0

Table 4.22 FlexRay Bus 1 termination

SW99	
SW99[1]	BUS1 termination: BP_1
SW99[2]	BUS1 termination: BM_1

4.4.5 FlexRay Connectors

Connections to the FlexRay interfaces are provided on connectors CN54 and CN61

Table 4.23 FlexRay transceiver signal connectors

CN54	FlexRay Signal	CN61	FlexRay Signal
1	NC	1	NC
2	BM_0	2	BM_1
3	NC	3	NC
4	BM_1	4	NC
5	NC	5	NC
6	NC	6	NC
7	BP_0	7	BP_1
8	BP_1	8	NC
9	NC	9	NC
10	GND	10	GND

4.5 SENT (Single Edge Nibble Transmission) Interfaces

The main board provides the connectors CN15 and CN100 for connecting two SENT interfaces. The SENT extension boards must be ordered from Renesas separately. Please refer to *1.4 Extension Boards* for details.

The SENT signals from the microcontroller on the piggyback board can be connected to the SENT circuitry on the main board by use of the following jumpers:

- SENT0: JP11
- SENT1: JP12

The SENT interfaces BUS power supply can be disconnected by use of the following jumpers:

- SENT0: JP16
- SENT1: JP40

The SENT interfaces power supply to an attached SENT sensor can be selected between constant voltage VDD5V0_SENT_x and the output of a DIGIO_x pin of the piggyback board by use of the following jumpers:

- SENT0: CN99
- SENT1: CN101

4.5.1 Circuit Diagram

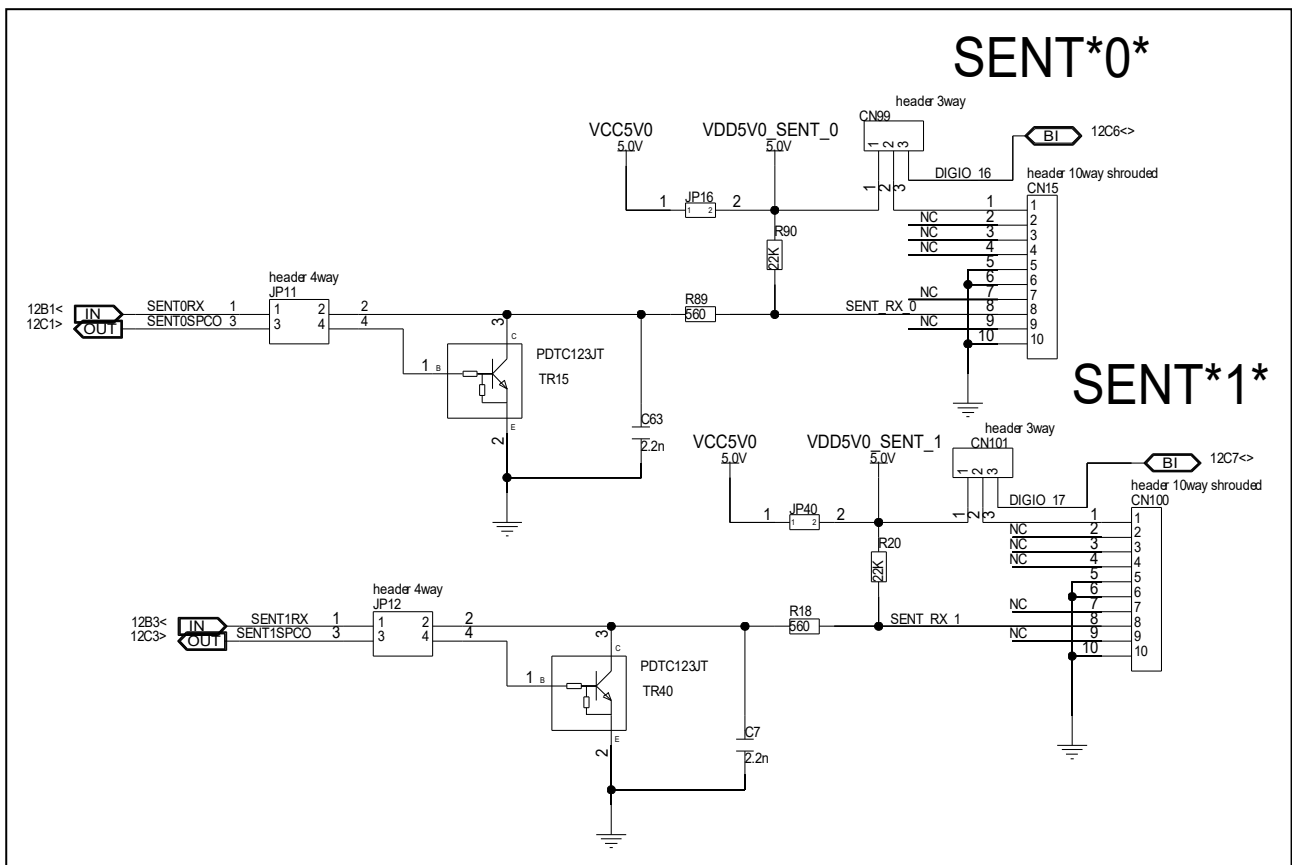

Figure 4.4 SENT interfaces

4.5.2 SENT Interface Connectors

Table 4.24 SENT interfaces connectors CN15, CN100

CN15 (SENT0)	
Pin	Voltage
1	Bus Power / Programming Power
2	–
3	–
4	–
5	GND
6	GND
7	–
8	SENT_RX_0
9	–
10	GND

CN100 (SENT1)	
Pin	Voltage
1	Bus Power / Programming Power
2	–
3	–
4	–
5	GND
6	GND
7	–
8	SENT_RX_1
9	–
10	GND

4.6 UART Interfaces

The main board provides two UART interfaces.

The UART0 and LIN0 interfaces share the CN14 connector. The jumper JP9 selects the CN14 function.

UART1 uses an FTDI chip to provide an USB interface on connector CN6.

The UART signals from the microcontroller on the piggyback board can be connected to the UART circuitry on the main board using the following jumpers:

- UART0: JP10
- UART1: CN94

Jumper JP13 is used to select the power supply for the FTDI USB to serial converter.

Table 4.25 Power supply for FTDI interface

JP13[1-2]	<ul style="list-style-type: none"> • Open: Vcc = DEBUG_VBUS • Closed: Vcc = VCC5V0
JP13[3-4]	<ul style="list-style-type: none"> • Open: Vcc = VDD_UART_IO • Closed: Vcc = VDDIOF

Jumper JP14 is used to select the power supply for UART0.

Table 4.26 Power supply for UART0 interface

JP14[1-2]	<ul style="list-style-type: none"> • Open: Vcc = VDDIOF_UART • Closed: Vcc = VDDIOF
-----------	---

4.6.1 Circuit Diagram

Below circuit diagram shows the circuitry for UART0 and UART1. UART1 provides a virtual COM port via USB interface.

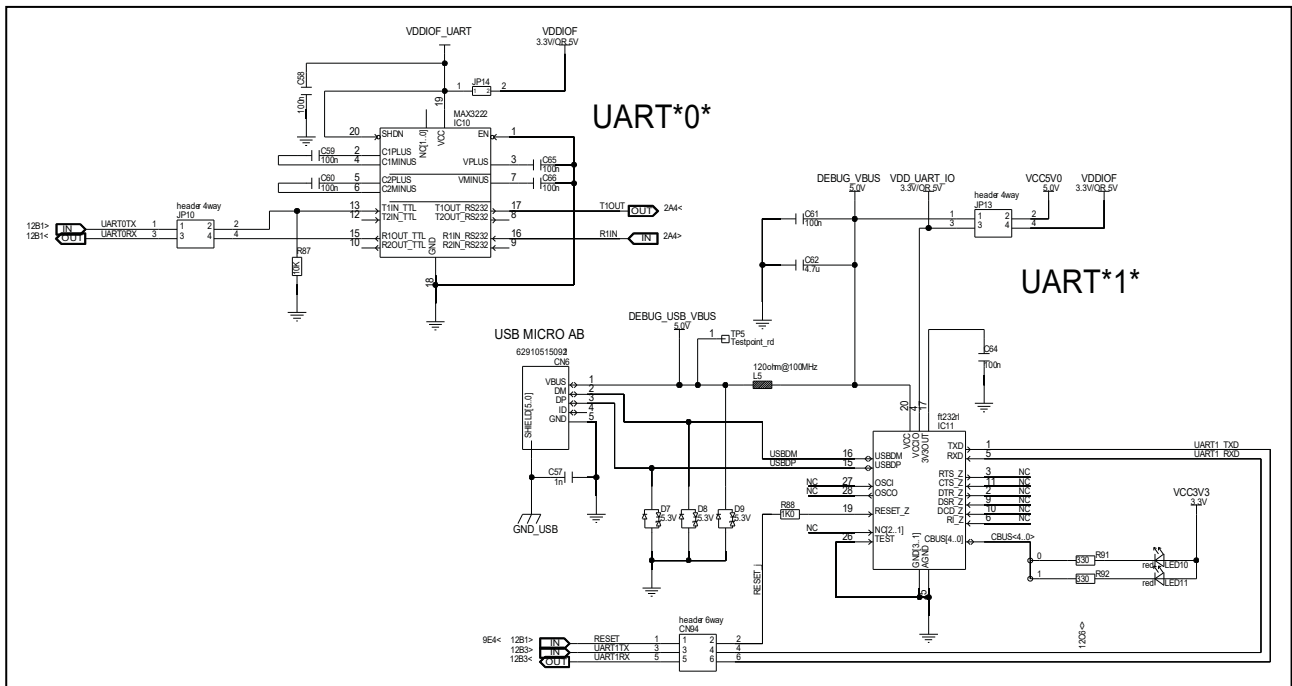

Figure 4.5 UART interface circuit diagram

4.6.2 UART Connector

UART1 provides 2 connectors. CN6 is the USB connector for the UART1 signals of the FTDI chip, CN94 is the connector for the UART signals to the piggyback board.

Table 4.27 UART interface connector CN94

Pin	Function
1	Reset input
3	UART1TX
5	UART1RX

Pin	Function
2	Reset
4	UART1_TxD
6	UART1_RxD

Table 4.28 USB Micro AB connector CN6

Pin	Function
1	USBVBUS
2	USBDM
3	USBDP

Pin	Function
4	–
5	GND

Jumper JP10 connects UART0 signals.

Table 4.29 USB Micro AB connector CN6

Pin	Function
JP10[1-2]	UART0TX
JP10[3-4]	UART0TX

4.7 Connection Cable for various Interfaces

The main board includes 8 connection cables from 10-pin DIL to 9-pin D-SUB, that can be used for CAN, LIN, FlexRay, UART0 and SENT connections to external hardware.

The DIL connector can be plugged-in to the connectors for the corresponding interfaces.

Table 4.30 shows the connection between the 10-pin connector and the 9-pin D- SUB connector, and the functions when the cable is connected to any of the interface ports providing 10 pin DIL connector.

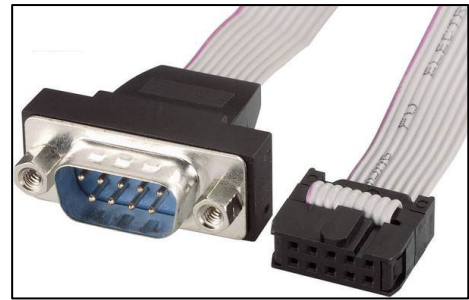

Figure 4.6 Interface cable

Table 4.30 Connection between 10-pin connector and 9-pin D-SUB connector

Pin no. on DIL connector	Pin no. on D-SUB connector	Function				
		LINn (n = 0 - 23)	CANn (n = 0 - 15)	FLEX0 / FLEX1	SENT0 / SENT1	UART0
1	1	–	–	–	DIGIO_16 (CN15, if CN99 [2-3] is set) DIGIO_17 (CN100, if CN101 [2-3] is set)	–
2	2	(R1IN, only CN14, not used for LIN)	CANnL	BM_0 (CN54) BM_1 (CN61)	–	R1IN (RxD)
3	3	GND (LIN0 only: if JP9[2-3] is set)	GND (when jumper is closed)	–	–	T1OUT (TxD) (if JP9[1-2] is set)
4	4	–	–	BM_1 (CN54) – (CN61)	–	–
5	5	–	–	–	GND	–
6	6	GND	–	–	GND	GND
7	7	LINn	CANnH	BP_0 (CN54) BP_1 (CN61)	–	(LIN0, not used for UART)
8	8	–	–	BP_1 (CN54) – (CN61)	SENT_RX_0 (CN15) SENT_RX_1 (CN100)	–
9	9	LINn_BAT	–	–	–	(LIN0_BAT, not used for UART)
10	–					

4.8 Ethernet Modules

The main board provides 2 connectors for Ethernet modules. The list of applicable Ethernet modules is shown in *Table 4.31 Available Ethernet Modules*.

Table 4.31 Available Ethernet Modules

Module Name	Interface	Ethernet PHY	Connection
Tessera TSE-BRPHY004 ^(Note) (not available anymore)	MII	Broadcom BCM89810	100BASE-T1
Tessera TSE-GbPHY004 ^(Note) (not available anymore)	GMII	Microchip KSZ9031	1000BASE-T 100BASE-TX 10BASE-T
Shimafuji ETHER Board	MII	Microchip KSZ8041	100BASE-TX 10BASE-T
Y-COMMON-100BASE-TX-LAN8700 (former Y-RH850-100BASE-TX-LAN8700)	MII	Microchip LAN8700	100BASE-TX 10BASE-T
Y-COMMON-1000BASE-T1-88Q2112 (former Y-RH850-1000BASE-T1-88Q2112)	SGMII	Marvell 88Q2112	100/1000BASE-T1

Note

The size of the Tessera Ethernet modules does not allow to connect 2 at the same time. If 2 Ethernet modules must be connected at the same time only the Shimafuji Ethernet modules can be used.

4.8.1 Circuit Diagram of Ethernet Connectors

Below circuit diagrams show the pin assignment on the connectors for Ethernet modules.

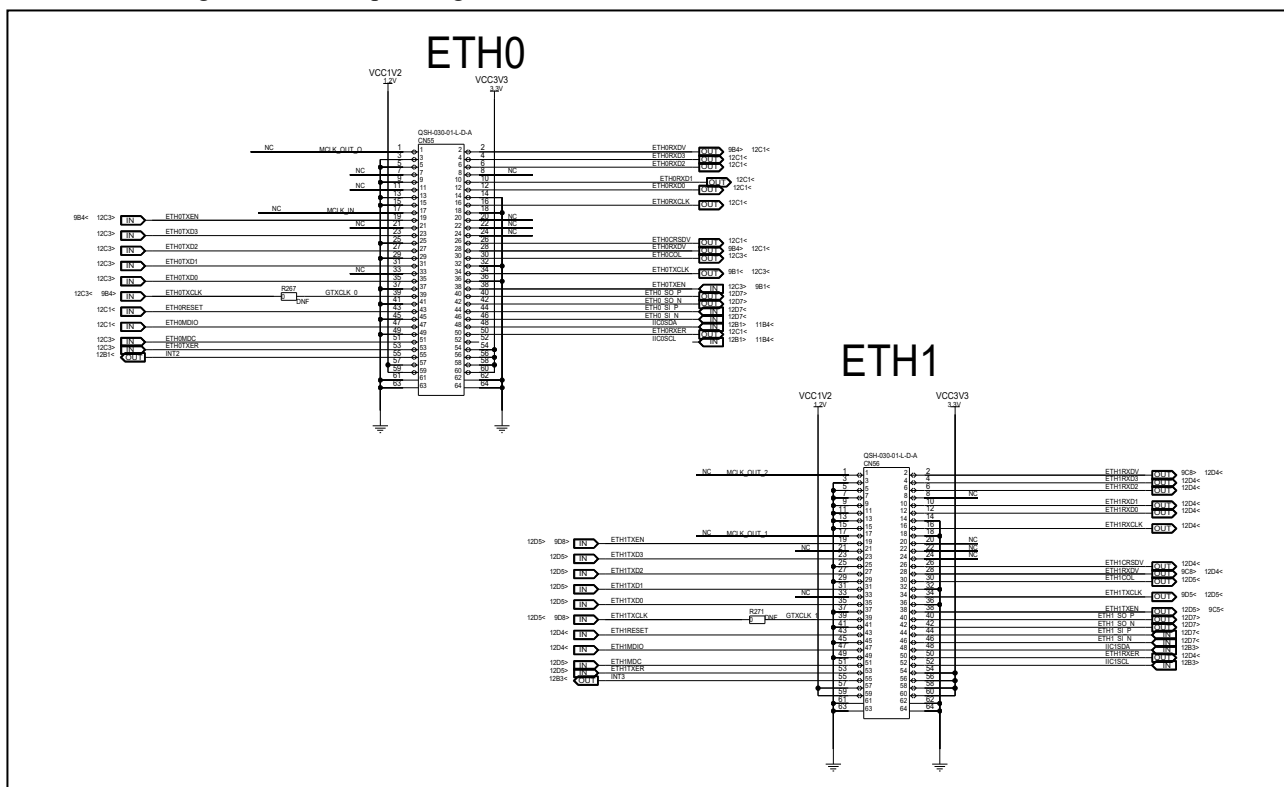

Figure 4.7 Ethernet module connector circuit

4.8.2 Pin Assignments of Ethernet Connectors

Table 4.32 Ethernet PHY (MII) connector CN55 pin assignment

Pin	Function
1	– (MCLK_OUT_0*)
3	GND
5	GND
7	–
9	GND
11	–
13	GND
15	GND
17	– (MCLK_IN*)
19	ETH0TXEN
21	–
23	ETH0TXD3
25	GND
27	ETH0TXD2
29	GND
31	ETH0TXD1

Pin	Function
2	ETH0RXDV
4	ETH0RXD3
6	ETH0RXD2
8	–
10	ETH0RXD1
12	ETH0RXD0
14	GND
16	ETH0RXCLK
18	GND
20	–
22	–
24	–
26	ETH0CRSDV
28	ETH0RXDV
30	ETH0COL
32	GND

Table 4.32 Ethernet PHY (MII) connector CN55 pin assignment

Pin	Function	Pin	Function
33	–	34	ETH0TXCLK
35	ETH0TXD0	36	GND
37	GND	38	ETH0TXEN
39	– (ETH0TXCLK can be connected if R267 is assembled) (GTXCLK_0*)	40	ETH0_SO_P
41	GND	42	ETH0_SO_N
43	ETH0RESET	44	ETH0_SI_P
45	GND	46	ETH0_SI_N
47	ETH0MDIO	48	IIC0SDA
49	GND	50	ETH0RXER
51	ETH0MDC	52	IIC0SCL
53	ETH0TXER	54	VCC3V3
55	INT2	56	VCC3V3
57	VCC1V2	58	VCC3V3
59	VCC1V2	60	VCC3V3
61	Common Shield GND	62	Common Shield GND
63	Common Shield GND	64	Common Shield GND

Note: * These MII signals are not connected on the main board.

Table 4.33 Ethernet PHY (MII) connector CN56 pin assignment

Pin	Function	Pin	Function
1	– (MCLK_OUT_2*)	2	ETH1RXDV
3	GND	4	ETH1RXD3
5	GND	6	ETH1RXD2
7	GND	8	–
9	GND	10	ETH1RXD1
11	GND	12	ETH1RXD0
13	GND	14	GND
15	GND	16	ETH1RXCLK
17	– (MCLK_OUT_1*)	18	GND
19	ETH1TXEN	20	–
21	–	22	–
23	ETH1TXD3	24	–
25	GND	26	ETH1CRSDV
27	ETH1TXD2	28	ETH1RXDV
29	GND	30	ETH1COL
31	ETH1TXD1	32	GND
33	–	34	ETH1TXCLK
35	ETH1TXD0	36	GND
37	GND	38	ETH1TXEN
39	– (ETH1TXCLK can be connected if R271 is assembled) (GTXCLK_1*)	40	ETH1_SO_P
41	GND	42	ETH1_SO_N
43	ETH1RESET	44	ETH1_SI_P
45	GND	46	ETH1_SI_N
47	ETH1MDIO	48	IIC1SDA
49	GND	50	ETH1RXER
51	ETH1MDC	52	IIC1SCL
53	ETH1TXER	54	VCC3V3
55	INT3	56	VCC3V3
57	VCC1V2	58	VCC3V3
59	VCC1V2	60	VCC3V3
61	Common Shield GND	62	Common Shield GND
63	Common Shield GND	64	Common Shield GND

Note: * These MII signals are not connected on the main board.

4.8.3 Use of Shimafuji Ethernet Board with Main Board

The Shimafuji ETHER Board requires some small modifications so it can be used with the RH850/X2X main board.

On the Shimafuji ETHER Board following modifications have to be applied:

- Remove resistor R6.
- Connect the left side of R6 to the upper side of R27.

Please refer to the figure below for details of the modification.

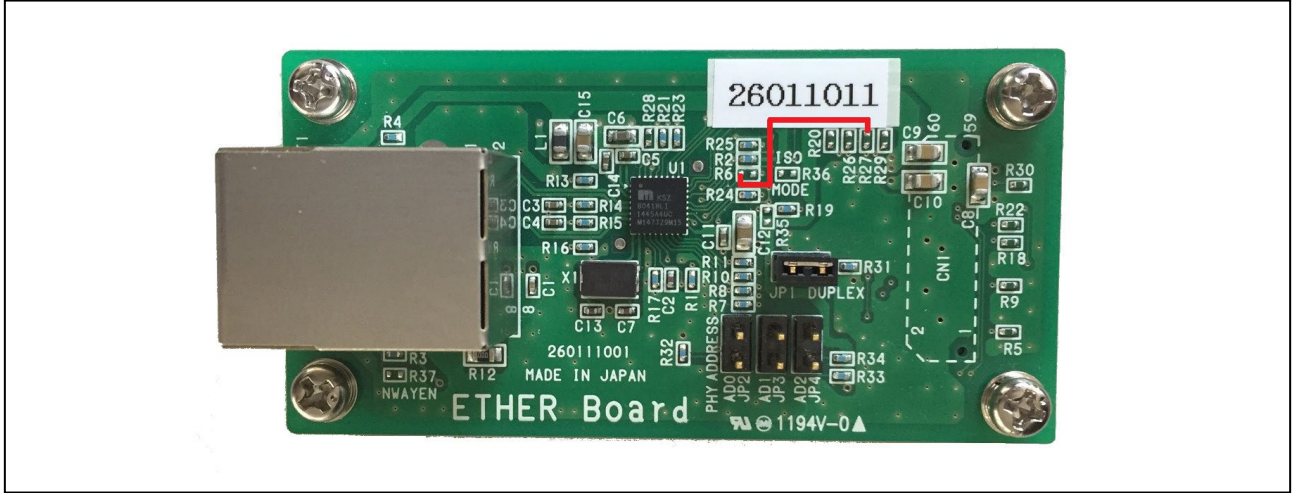

Figure 4.8 Modification of Shimafuji ETHER Board

4.8.5 Circuit Diagram of Renesas Ethernet Board Y-COMMON-1000BASE-T1-88Q2112

The picture below shows the circuit diagram of the Ethernet board Y-COMMON-1000BASE-T1-88Q2112.

The base address of the Marvell PHY is 0x0000.

Note

The former name of this extension board was Y-RH850-1000BASE-T1-88Q2112.

Please check the piggyback board schematic carefully to ensure that on the piggyback board all necessary signals are connected from processor to the main board connector.

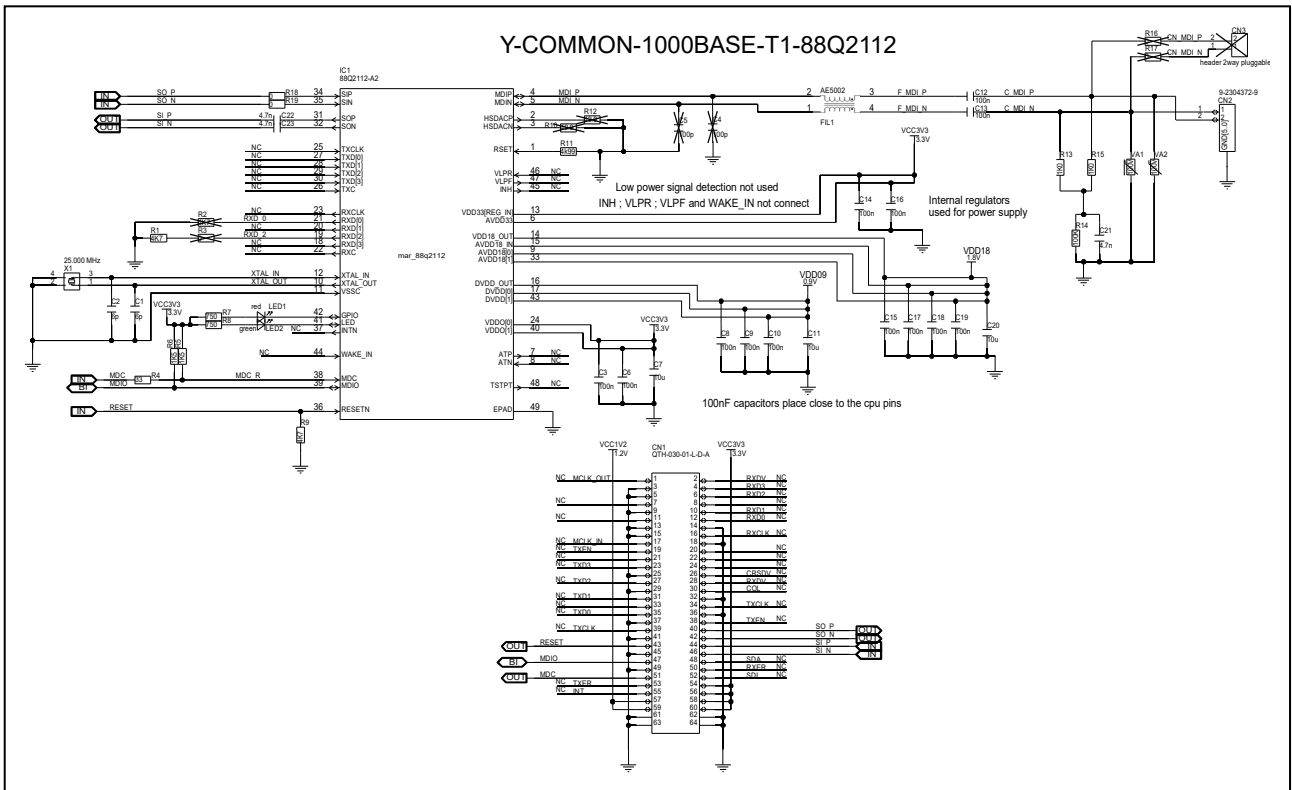

Figure 4.10 Circuit diagram of Renesas Ethernet board Y-COMMON-1000BASE-T1-88Q2112

4.9 PSI5/PSI5S Interfaces

The main board provides the connector CN62 for connecting several PSI5/PSI5S compatible sensors.

4.9.1 Circuit Diagram

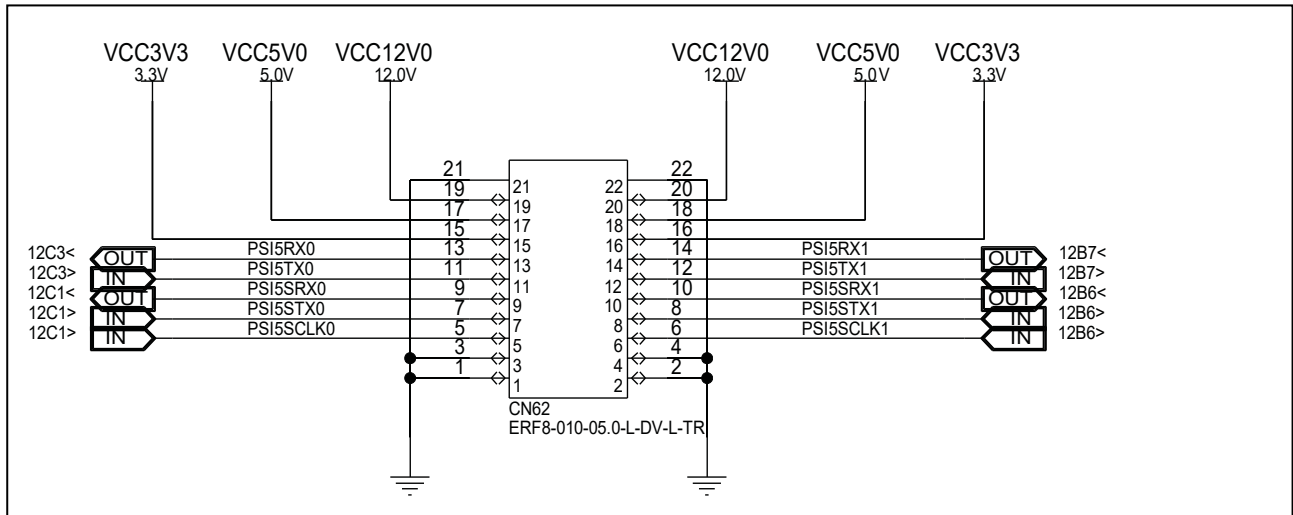

Figure 4.11 PSI5/PSI5S interface circuit diagram

4.9.2 PSI5/PSI5S Interface Connector

Table 4.34 PSI5/PSI5S interface connector CN62 pin assignment

Pin	Voltage
1	GND
3	GND
5	PSI5SCLK0
7	PSI5STX0
9	PSI5SRX0
11	PSI5TX0
13	PSI5RX0
15	VCC3V3
17	VCC5V0
19	VCC12V0
21	GND

Pin	Voltage
2	GND
4	GND
6	PSI5SCLK1
8	PSI5STX1
10	PSI5SRX1
12	PSI5TX1
14	PSI5RX1
16	VCC3V3
18	VCC5V0
20	VCC12V0
22	GND

4.10 eMMC/SFMA Module

The main board incorporates one connector for an eMMC/SFMA module. The eMMC/SFMA extension board must be ordered from Renesas separately. Please refer to *1.4 Extension Boards* for details.

Below circuit diagrams show the pin assignment on the connector for eMMC/SFMA module.

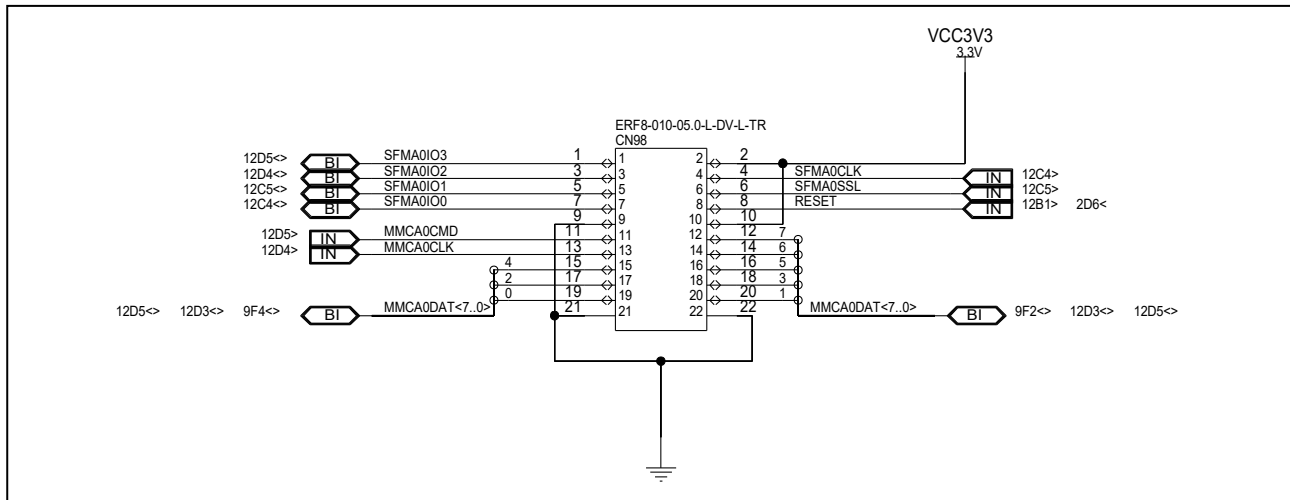

Figure 4.12 eMMC/SFMA module connector circuit

4.10.1 eMMC/SFMA Interface Connector

Table 4.35 eMMC / SFMA interface connector CN98

Pin	Function
1	SFMA0IO3
3	SFMA0IO2
5	SFMA0IO1
7	SFMA0IO0
9	GND
11	MMCA0CMD
13	MMCA0CLK
15	MMCA0DAT4
17	MMCA0DAT2
19	MMCA0DAT0
21	Common Shield GND

Pin	Function
2	VCC3V3
4	SFMA0CLK
6	SFMA0SSL
8	RESET
10	VCC3V3
12	MMCA0DAT7
14	MMCA0DAT6
16	MMCA0DAT5
18	MMCA0DAT3
20	MMCA0DAT1
22	Common Shield GND

4.10.2 Extension Board Details

The extension board includes one eMMC IC (Swissbit SFEM4096B1EA1, 4GB NAND flash) and one serial flash IC (Macronix MX25L51245GMISFMA, 512Mbit).

Figure 4.13 shows the circuit diagram of the eMMC/SFMA extension board.

4.11.2 Enable Touch Display

All touch screen related signals from the microcontroller on the piggyback board can be connected to the touch screen circuit on the main board using following switches:

- SW84: CSI-signals
- SW86: I2C-signals

The displays power supply can be connected using the jumpers JP119 and JP120.

4.11.3 Usage Information

The 2.8” display is equipped with a capacitive touch controller FT6206.

This touch controller can be controlled via I²C interface. The I²C interface on the display PCB is enabled by connecting the solder bridges for SDA and SCL signals. These bridges are marked with a blue circle in the circuit diagram below.

The following documents are available on the internet to set up the display:

- [FT6x06_AN_public_ver0.1.3.pdf](#) (Application Note for FT6x06 CTPM from FocalTech)
- [FT6x06+Datasheet_v0.1_Preliminary_20120723.pdf](#) (Self-Capacitive Touch Panel Controller)
- [Adafruit-2-8-tft-touch-shield-v2.pdf](#) (Adafruit 2.8” TFT Touch Shield v2 from Adafruit learning system)

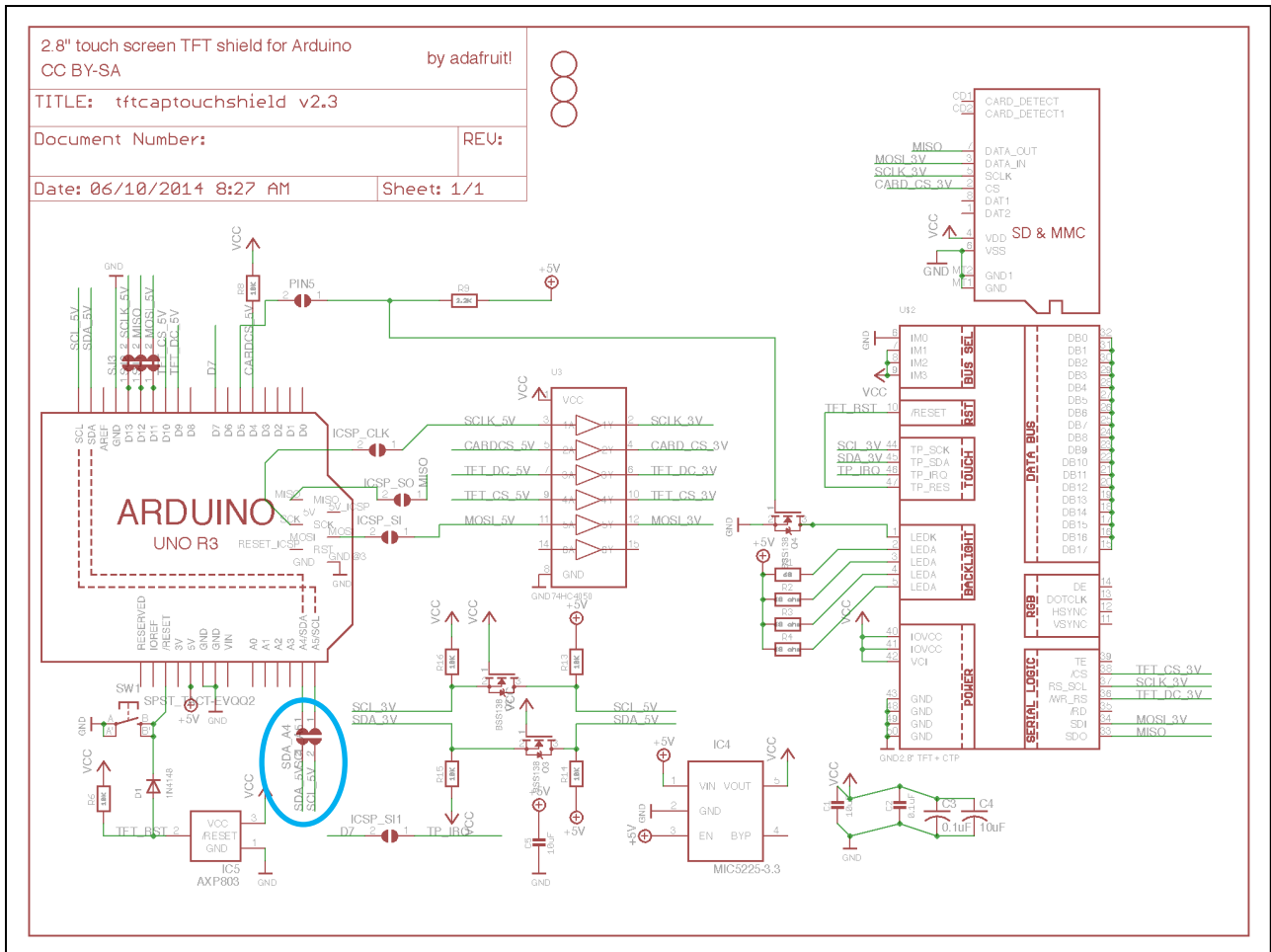

Figure 4.15 Touch display

4.11.4 Touch Display Connectors

Table 4.37 Touch Display connectors CN57 to CN60 pin assignment

CN57		CN58		CN59		CN60	
Pin	Function	Pin	Function	Pin	Function	Pin	Function
1	–	1	CSI1CS3_s ¹	1	–	1	–
2	–	2	DIGIO_18_s ¹	2	–	2	GND
3	–	3	CSI1CS2_s ¹	3	–	3	GND
4	–	4	CSI1SO_s ¹	4	–	4	V_DISP_5V0 ³
5	CSI1CS1_s ¹	5	CSI1SI_s ¹	5	IIC0SDA ²	5	V_DISP_3V3 ³
6	CSI1CS2_s ¹	6	CSI1SCLK_s ¹	6	IIC0SCL ²	6	DIGIO_4_s ²
7	–	7	–			7	–
8	–	8	–			8	–
		9	–				
		10	–				

Notes: ¹ These signals can be switched on/off by switch SW84.

² These signals can be switched on/off by switch SW86.

³ These display power supplies can be enabled/disabled via jumpers JP119 and JP120.

4.12 RGB Illuminated Rotary Encoder

The main board is equipped with a rotary encoder switch IC52 that has an illuminated transparent shaft.

The rotary encoder rotation position signals can be connected to the microcontroller on the piggyback board by SW83 or via connector CN103.

The rotary encoder RGB LED signals can be connected by SW81 or connector CN104.

The rotary encoder RGB LED current for each color can be measured with the analog voltage connected by SW80.

The rotary encoder RGB LED common anode power supply can be connected to board VCC5V0 with JP155.

The rotary encoder position signal reference voltage can be connected to board VDDIOF with JP156.

Table 4.38 RGB Rotary Encoder signal jumpers

Function	SWx/JPx
Position detection	SW83/CN103
RGB PWM input	SW81/CN104
RGB current A/D feedback	SW80
Encoder position signal reference voltage	JP156
Rotary encoder power supply	JP155

4.12.1 Circuit Diagram

Below circuit diagram shows the circuitry for rotary encoder.

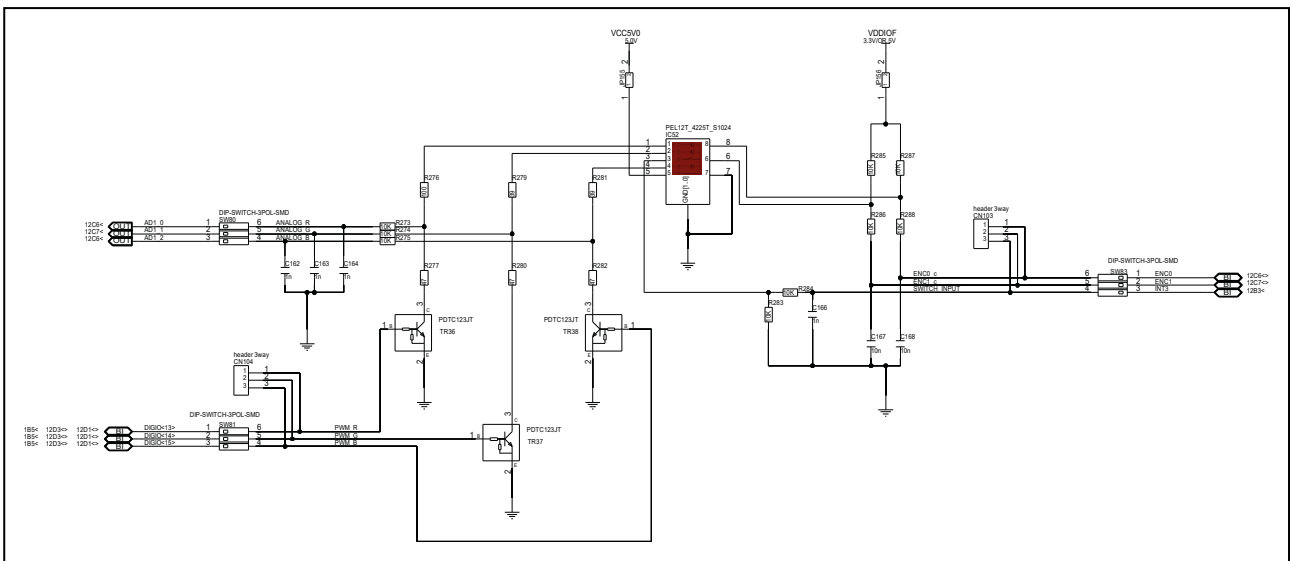

Figure 4.16 Rotary Encoder

4.13 LED CSI Driver for LED Ring Indicator

The main board provides an LED ring indicator with 16 blue LEDs.

The ring indicators 16 LEDs are located around the rotary encoder switch.

To drive the 16 LEDs a led driver with CSI interface is used.

The CSI interface signals from the microcontroller on the piggyback board can be connected to the LED driver circuitry on the main board by switch SW82.

All these signals can be checked on connector CN102.

The LED CSI driver for ring indicator circuitry power supply can be connected to the main board by jumper JP154.

4.13.1 Circuit Diagram

Below picture shows the serial control of the circular LED circuit.

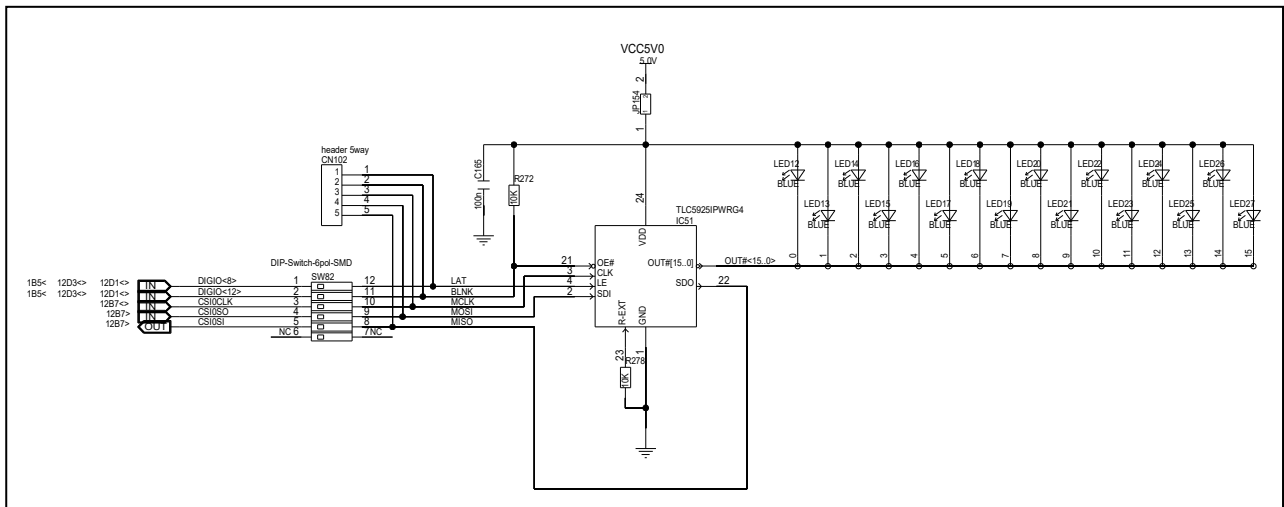

Figure 4.17 LED CSI driver for LED ring indicator

SW82 is used to connect the serial interface signals from the CSI driver IC to the controller on the piggyback board. If a switch is set to “On” this signal is connected.

Table 4.39 Serial interface connection

SW82	Controller signal	CSI driver signal	Description
SW82[1]	DIGIO[8]	LAT	Data strobe
SW82[2]	DIGIO[9]	BLNK	Output enable
SW82[3]	CSIOCLK	MCLK	Clock input
SW82[4]	CSIOSO	MOSI	Serial data input
SW82[5]	CSIOSI	MISO	Serial data output
SW82[6]	NC	NC	

4.14 Interrupt Push Buttons

Two push buttons are available to trigger the interrupts NMI and INT0:

- Pushing switch SW52 issues an NMI signal to the piggyback board, if switch SW87[1] is closed
- Pushing switch SW53 issues an INT0 signal to the piggyback board, if switch SW87[2] is closed

The pin header JP123 can be used to output the signals to some other external hardware.

If no interrupt is pending, the NMI and INT0 signals are set to VDD_PUSH. VDD_PUSH = VDDIOF must be activated by closing JP122.

4.14.1 Circuit Diagram

This picture shows the circuit diagram of the interrupt switches.

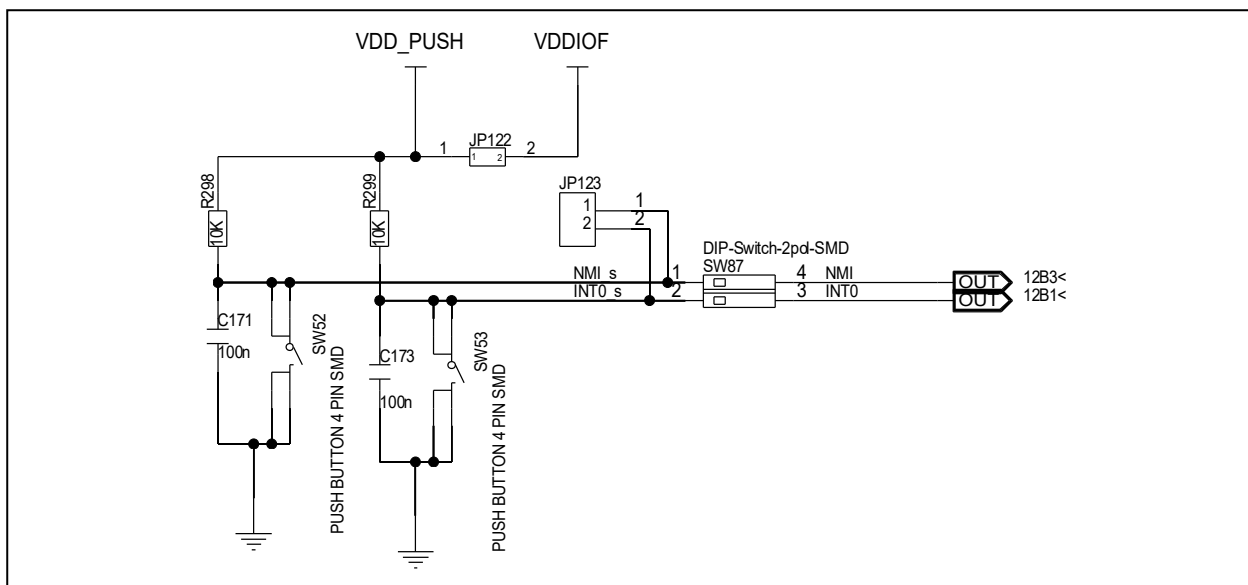

Figure 4.18 Interrupts push buttons

Table 4.40 Interrupt signal output on JP123 SW88

JP123	Function
JP123[1]	Output NMI interrupt signal
JP123[2]	Output INT0 interrupt signal

Table 4.41 Enable interrupt signals on switch SW87

Switch	Function
SW87[1]	Enable NMI interrupt signal for piggyback board
SW87[2]	Enable INT0 interrupt signal for piggyback board

4.15 A/D Measurements

The main board includes 2 potentiometer circuits in order to provide variable voltage levels on the ADC[1:0] signals as inputs to the piggyback board's microcontroller's A/D Converter.

- R301 generates a signal for ADC[1], if SW88[2] is closed.
- R303 generates a signal for ADC[0], if SW88[1] is closed.

The analog voltages can be checked on CN63 pin header.

The voltage can be adjusted between VDD_ADC and GND.

VDD_ADC = VDDIOF must be switched on by closing jumper JP124.

4.15.1 Circuit Diagram

This picture shows the A/D measurement circuit.

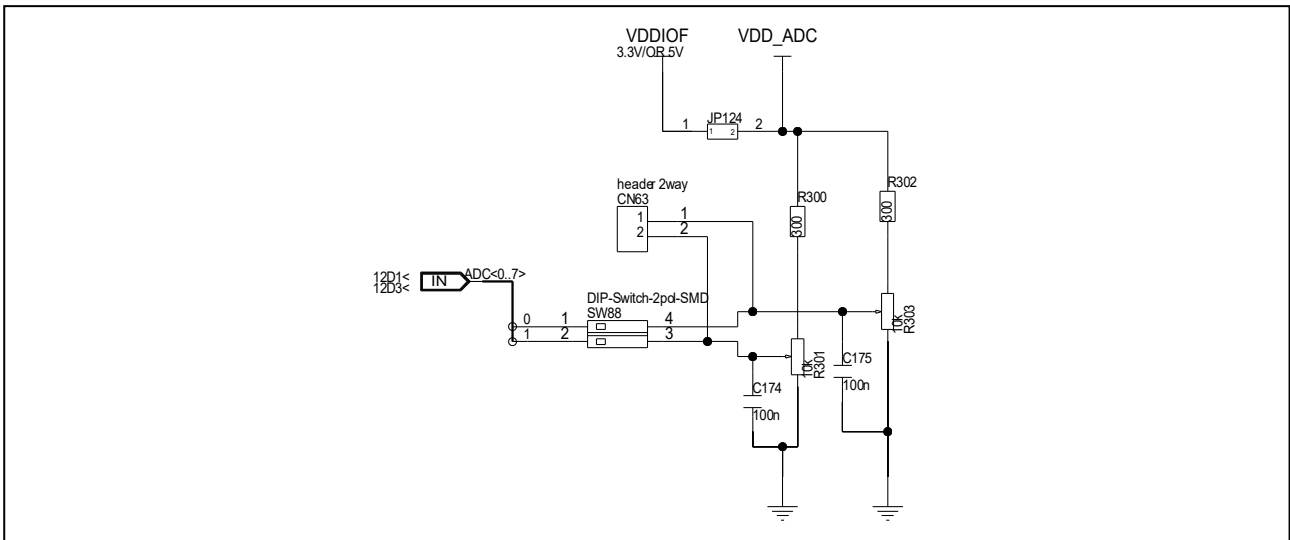

Figure 4.19 A/D measurements

4.15.2 Connector

Table 4.42 Analog signal connection on switch SW88

Switch	Function
SW88[1]	Connect signal from R303 to analog input ADC[0]
SW88[2]	Connect signal from R301 to analog input ADC[1]

4.16 Signal LEDs

Four blue LEDs are provided to allow visual outputs of four signals.

The four signal LEDs can be driven by DIGIO[3:0] signals or signals from the pin header CN9

Table 4.43 Signal LEDs

LED	SW43 number	SW43 closed	SW43 open
LED9	1	DIGIO[0]	CN9 pin 1
LED8	2	DIGIO[1]	CN9 pin 2
LED7	3	DIGIO[2]	CN9 pin 3
LED6	4	DIGIO[3]	CN9 pin 4

4.16.1 Circuit Diagram

This circuit diagram shows signal LED connection.

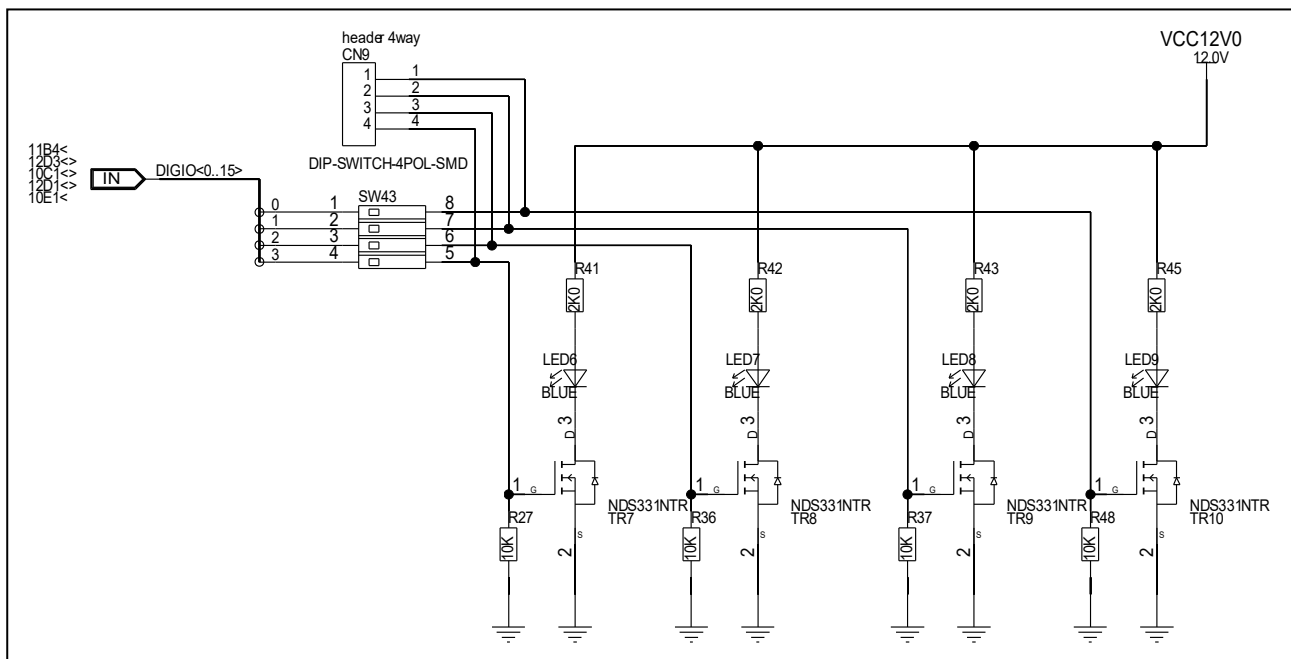

Figure 4.20 Signal LEDs

5. Precautions

5.1 Debugging and Flash Programming Signals

In some devices some of the debugging or flash programming signals like FLMD1 signal are in a pin sharing on the same device pin with some interface signals.

When the shared interface is connected to its driver circuitry there may be a disturbance of debugger or flash programmer function.

Make sure to disconnect any driver receive signal that actively drives some shared debugging or flash programming signal when using debugger or flash programmer.

5.2 Differences between Mass Production and Prototype Version of the Main Board

Some signals on the LED CSI interface and the rotary encode have been changed.

Table 5.1 Signal differences between mass production and prototype board

Signal	Mass production board D017347_06_V02	Prototype board D017347_06_V01
LED CSI OE	DIGIO_12	DIGIO_11
LED CSI LE	DIGIO_8	DIGIO_10
Encode button interrupt	INT3	INT1

The prototype board does not have differential pair connections between the Ethernet connectors and the piggyback board connectors. These are the additional connections on the mass production board.

Table 5.2 Twisted pair Ethernet signals added on mass production board

Signal	Ethernet connector	Piggyback board connector
ETH0_SO_P	CN55[40]	CN3[100]
ETH0_SO_N	CN55[42]	CN3[102]
ETH0_SI_P	CN55[44]	CN3[106]
ETH0_SI_N	CN55[46]	CN3[108]
ETH1_SO_P	CN56[40]	CN3[112]
ETH1_SO_N	CN56[42]	CN3[114]
ETH1_SI_P	CN56[44]	CN3[118]
ETH1_SI_N	CN56[46]	CN3[120]

6. Mechanical Dimensions

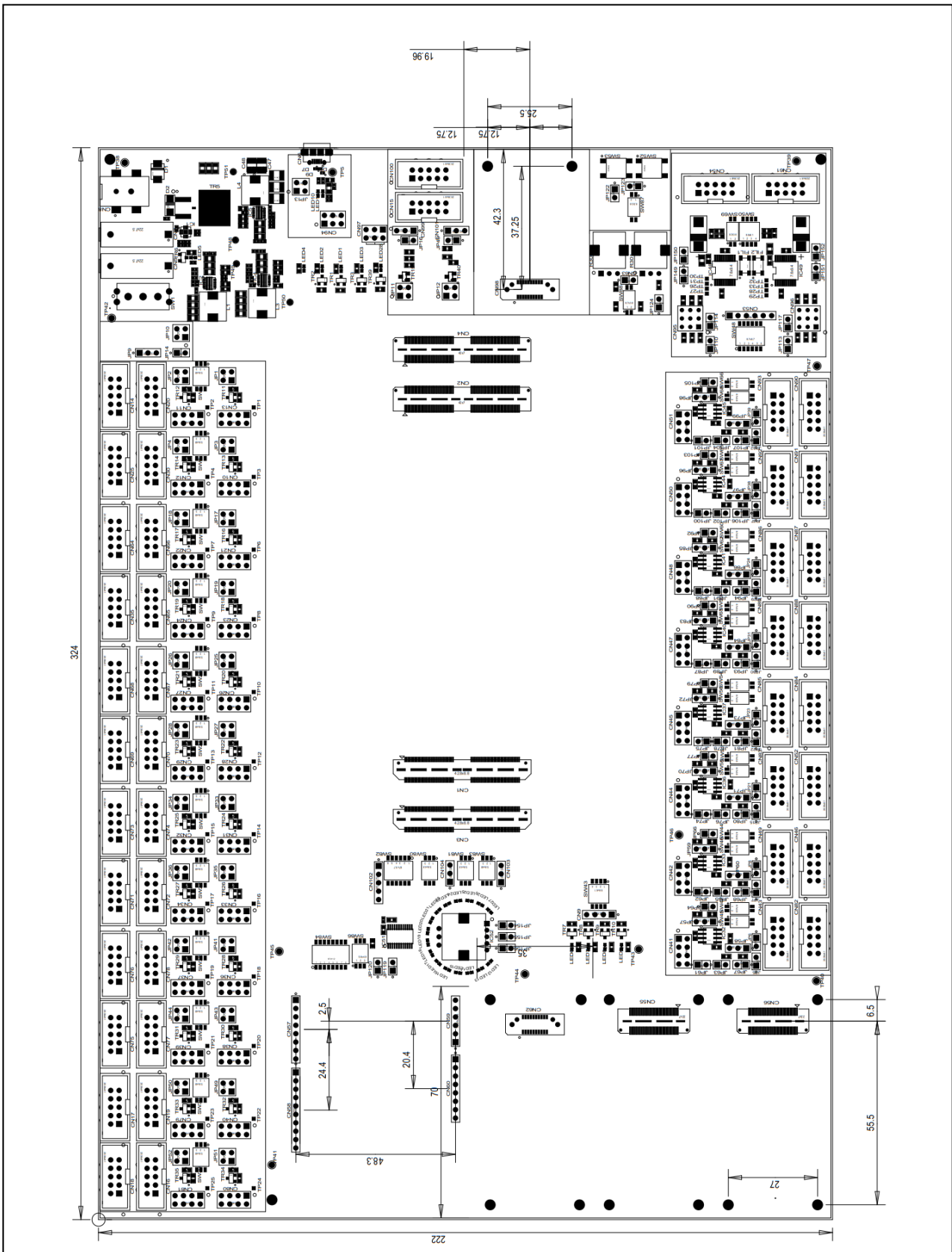

Figure 6.1 Mechanical dimensions

7. Schematics

CAUTION

The schematics shown in this document are not intended to be used as a reference for mass production. Any usage in an application design is the sole responsibility of the customer.

The following components described in the schematics are not provided with the board upon delivery:

- Oscillators and resonators: OSC1, X3
- Capacitors: C97, C98, C113, C116,
- Resistors: R2 – R4, R6, R15 – R18, R21 – R23, R104 – R107, R127 – R129, R137, R138 – R141, R143,

The above components are indicated with "DNF/DNB" in the schematics.

The following components described in the schematics are provided with but not mounted on the board upon delivery:

- Standard 4 mm power lab sockets CN8 – CN11
- three resonators HC49 (16/20/24 MHz)
- 49 jumpers, 2.54 mm, black

The above components are indicated with "DO NOT FIT / TO DELIVER WITH THE BOARD" in the schematics.

7.1 Page 1

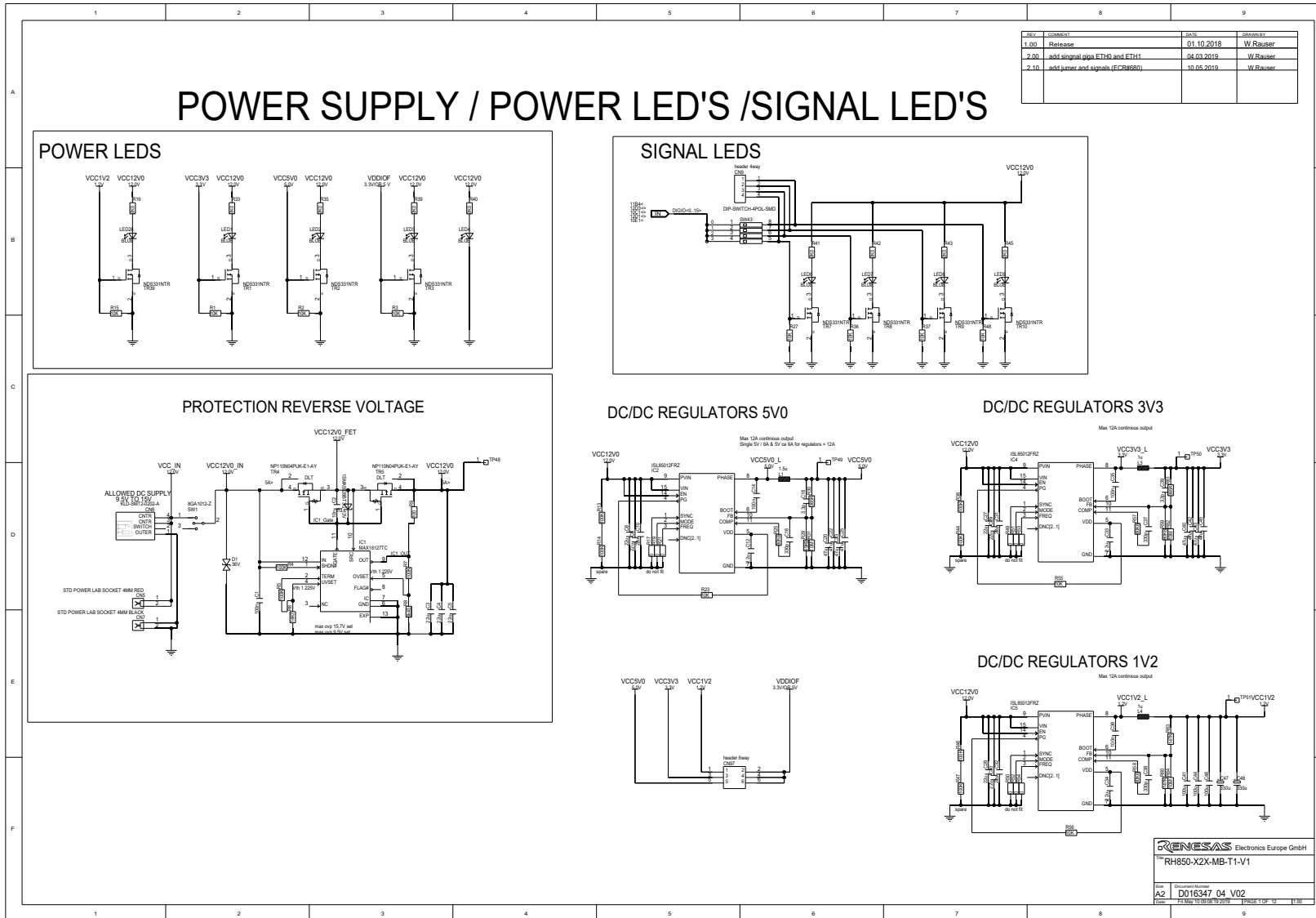

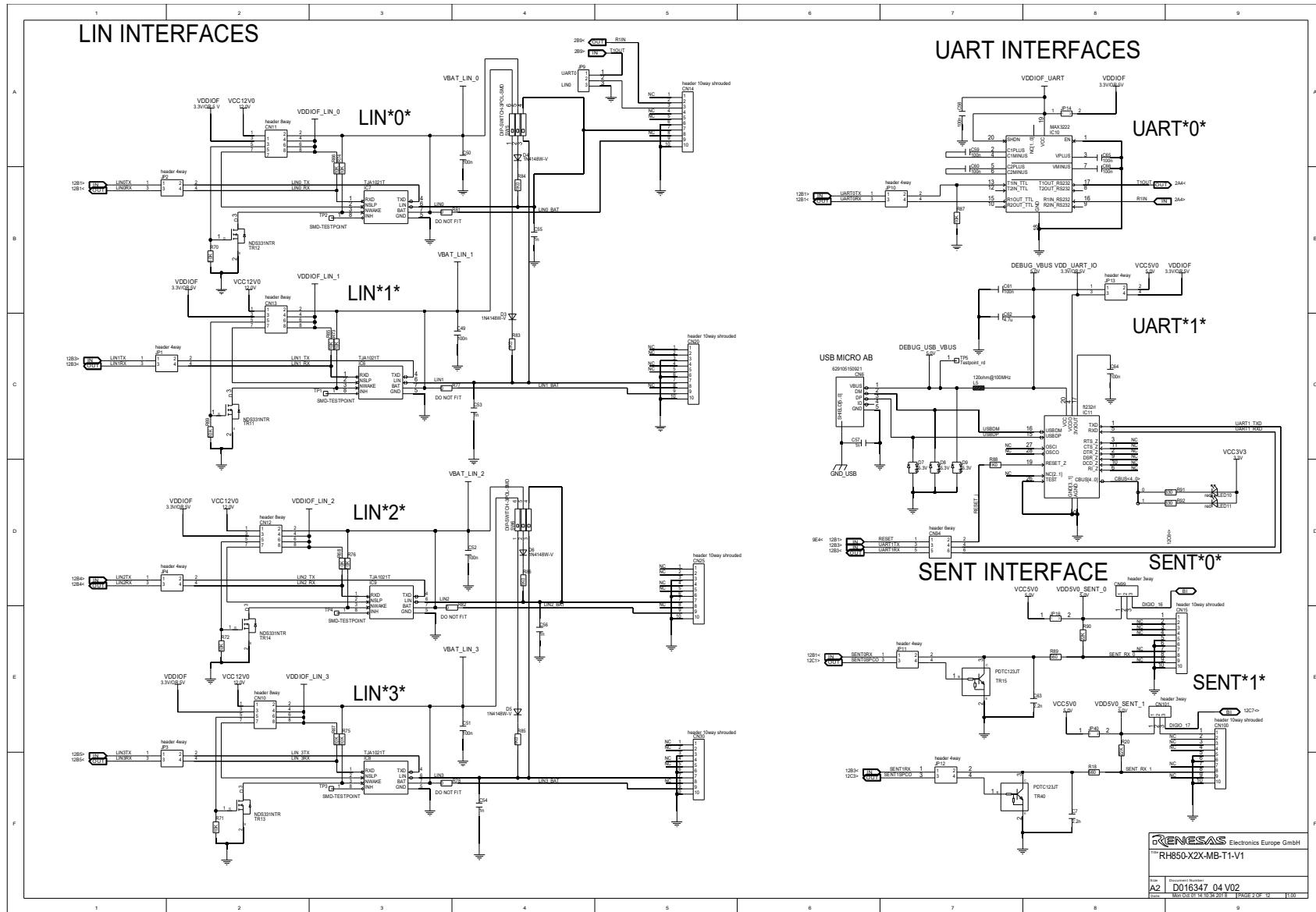

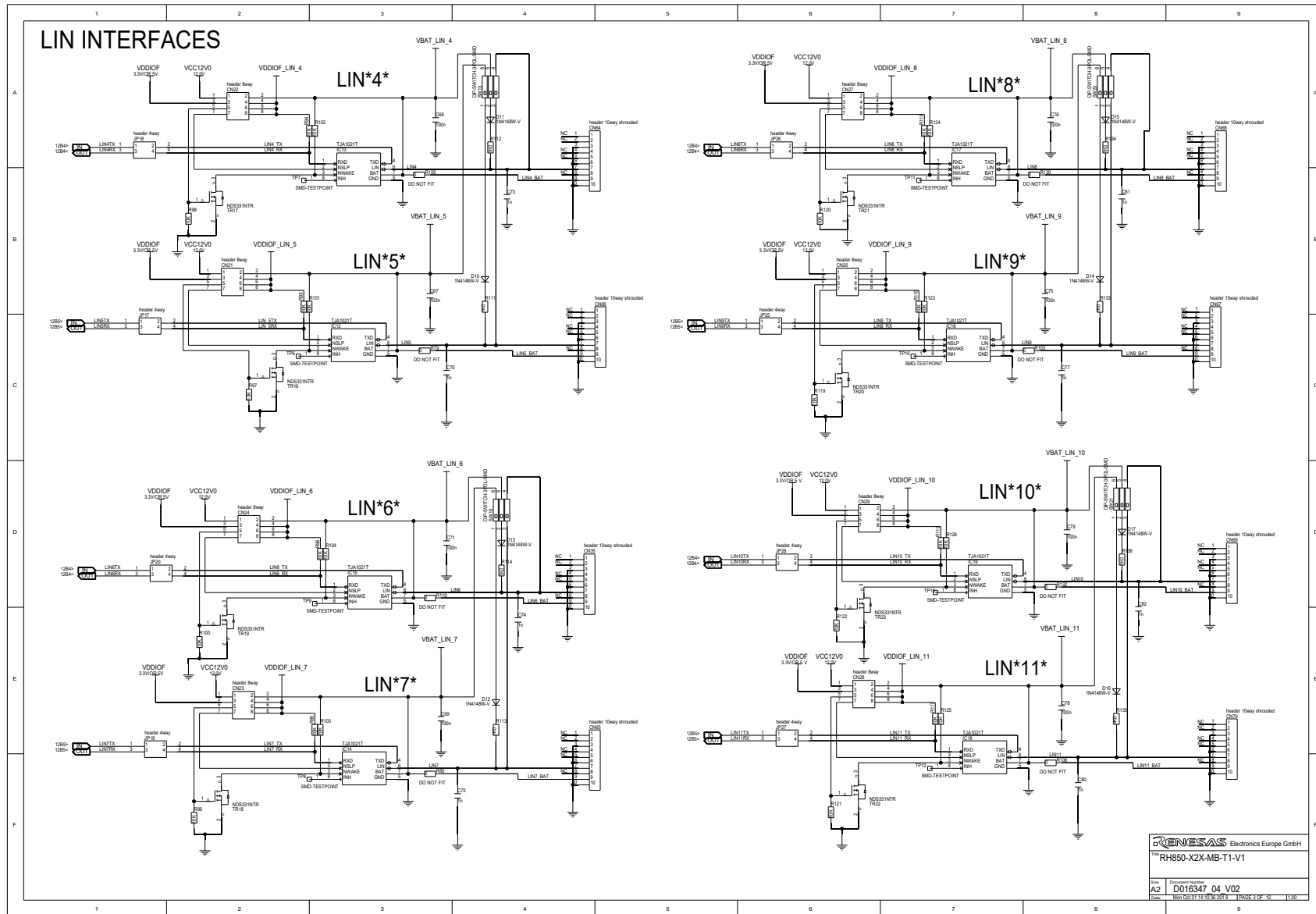

Electronics Europe GmbH
 RH850-X2X-MB-T1-V1
 Drawing No. A2 D018347_04_V02
 File: MCH5011410362018_P0001_01_11.nw

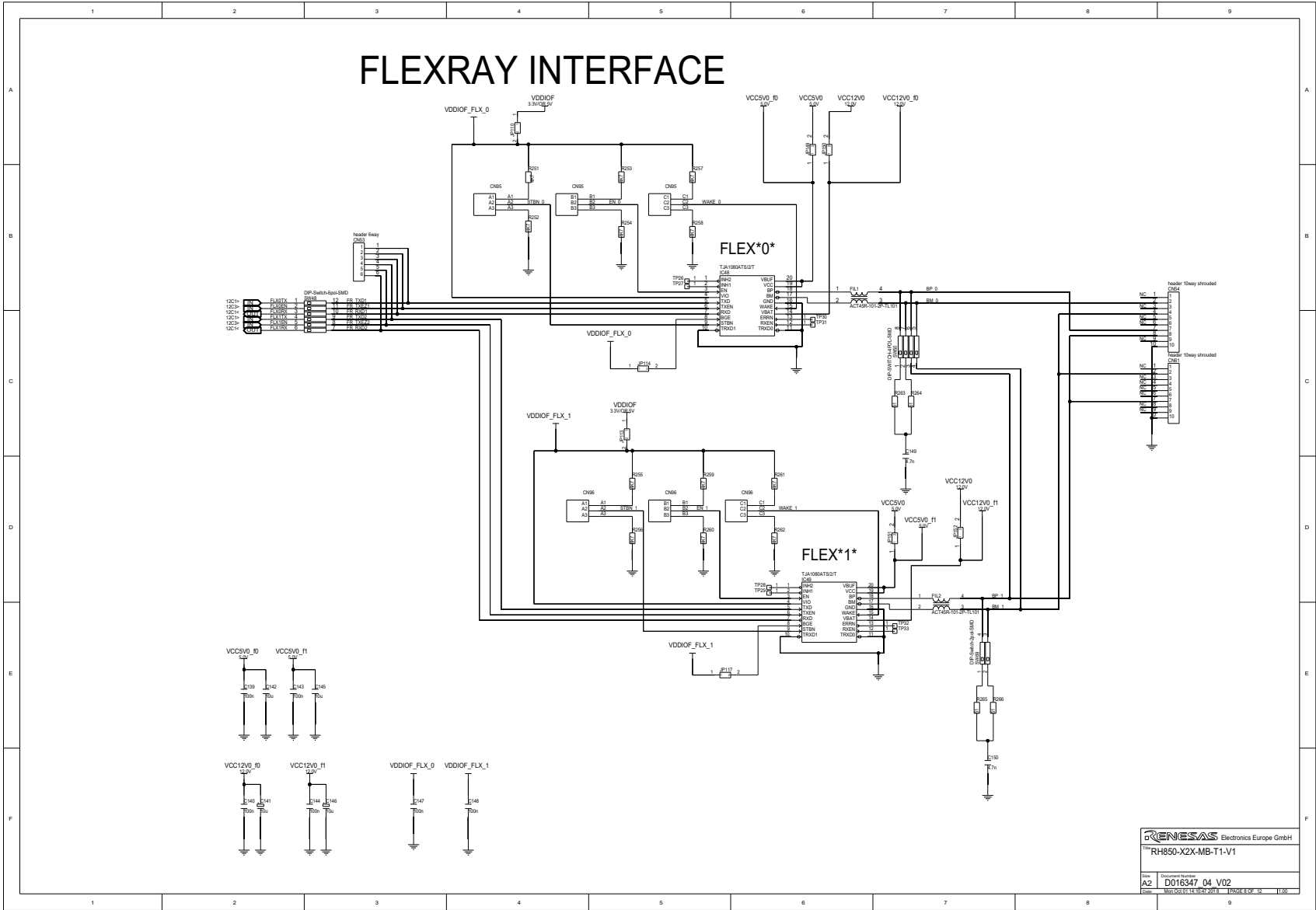

Electronics Europe GmbH
 RH850-X2X-MB-T1-V1
 Rev. 1.00
 A2 D018347_04_V02
 File: M018347_04_V02_78PAGE10F10

Revision History

Rev.	Date	Description	
		Page	Summary
V1.00	2019-08-08	–	Initial release (Hardware revision D016347_06_V02)
V1.01	2020-06-10	–	Added links for touch displays Added note to <i>Table 4.31 Available Ethernet Modules</i>
V1.02	2021-08-04	–	Corrected the note for usage of Shimafuji ETHER board in chapter 4.8.3 <i>Use of Shimafuji Ethernet Board with Main Board</i>
V1.03	2023-05-12	44	Added chapter 4.7 <i>Connection Cable for various Interfaces</i> Added in formation about Renesas Ethernet extension boards <i>1.4 Extension Boards</i> <i>4.8 Ethernet Modules</i>
V1.04	2024-04-29	8, 45 50	Updated availability information for Tessera Ethernet boards. <i>1.4 Extension Boards</i> <i>4.8 Ethernet Modules</i> Updated circuit diagrams for Renesas Ethernet Board Y-COMMON-100BASE-TX-LAN8700 <i>4.8.4Circuit Diagram of Renesas Ethernet Board Y-COMMON-100BASE-TX-LAN8700</i>
V1.05	2025-01-28	45	Updated information for Ethernet extension modules in chapter 4.8 <i>Ethernet Modules.</i>
V1.06	2025-09-12	7	Updated information about different board versions Y-RH850-X2X-MB-T1-V1 and Y-RH850-X2X-MB-T1-V1-JP in chapter 1 <i>Overview</i>
V1.07	2026-03-30	51	Updated circuit diagram for Ethernet circuit in <i>4.8.5 Circuit Diagram of Renesas Ethernet Board Y-COMMON-100BASE-T1-88Q2112</i>

RH850/X2X Main Board T1-V1 User's Manual

Publication Date: Rev.1.07 March 30, 2026

Published by: Renesas Electronics Europe

**SALES OFFICES**

Renesas Electronics Corporation

<http://www.renesas.com>

Refer to "<http://www.renesas.com/>" for the latest and detailed information.**Renesas Electronics Corporation**

TOYOSU FORESIA, 3-2-24 Toyosu, Koto-ku, Tokyo 135-0061, Japan

Renesas Electronics America Inc.

1001 Murphy Ranch Road, Milpitas, CA 95035, U.S.A.

Tel: +1-408-432-8888, Fax: +1-408-434-5351

Renesas Electronics Canada Limited

9251 Yonge Street, Suite 8309 Richmond Hill, Ontario Canada L4C 9T3

Tel: +1-905-237-2004

Renesas Electronics Europe GmbH

Arcadiastrasse 10, 40472 Düsseldorf, Germany

Tel: +49-211-6503-0, Fax: +49-211-6503-1327

Renesas Electronics (China) Co., Ltd.

Room 101-T01, Floor 1, Building 7, Yard No. 7, 8th Street, Shangdi, Haidian District, Beijing 100085, China

Tel: +86-10-8235-1155, Fax: +86-10-8235-7679

Renesas Electronics (Shanghai) Co., Ltd.

Unit 301, Tower A, Central Towers, 555 Langao Road, Putuo District, Shanghai 200333, China

Tel: +86-21-2226-0888, Fax: +86-21-2226-0999

Renesas Electronics Hong Kong Limited

Unit 1601-1611, 16/F., Tower 2, Grand Century Place, 193 Prince Edward Road West, Mongkok, Kowloon, Hong Kong

Tel: +852-2265-6688, Fax: +852 2886-9022

Renesas Electronics Taiwan Co., Ltd.

13F, No. 363, Fu Shing North Road, Taipei 10543, Taiwan

Tel: +886-2-8175-9600, Fax: +886 2-8175-9670

Renesas Electronics Singapore Pte. Ltd.

80 Bendemeer Road, Unit #06-02 Hyflux Innovation Centre, Singapore 339949

Tel: +65-6213-0200, Fax: +65-6213-0300

Renesas Electronics Malaysia Sdn.Bhd.

Unit No 3A-1 Level 3A Tower 8 UOA Business Park, No 1 Jalan Pengaturcara U1/51A, Seksyen U1, 40150 Shah Alam, Selangor, Malaysia

Tel: +60-3-5022-1288, Fax: +60-3-5022-1290

Renesas Electronics India Pvt. Ltd.

No.777C, 100 Feet Road, HAL 2nd Stage, Indiranagar, Bangalore 560 038, India

Tel: +91-80-67208700

Renesas Electronics Korea Co., Ltd.

17F, KAMCO Yangjae Tower, 262, Gangnam-daero, Gangnam-gu, Seoul, 06265 Korea

Tel: +82-2-558-3737, Fax: +82-2-558-5338

RH850/X2X Main Board



Renesas Electronics Corporation

R20UT4459ED0107