EBC10320 Evaluation Board

SSR GaN-SiP Design, GaN Ecosystem, 100W/24V

Introduction

This document explains how to set up the EBC10320 evaluation board.

Target Device

EBC10320 – 100W/24V adaptor design.

Notice

The EBC10320 evaluation board is powered by AC main voltage. When powered, the board generates non-insulated high voltages that may produce electrical shock, burn, and/or fire hazards, resulting in risk of property damage, personal injury, and/or death.

When the board is powered, never touch it or its electrical circuits because they may cause electrical shock.

Contents

1. Overview	2
2. Equipment and Setup	2
2.1 Recommended Equipment	2
2.2 Setup and Operation	3
3. System Power Off	3
4. Ordering Information	4
5. Revision History	4

1. Overview

The EBC10320 evaluation board supports 24V/100W load.

The current and power can be adjusted by electric load.

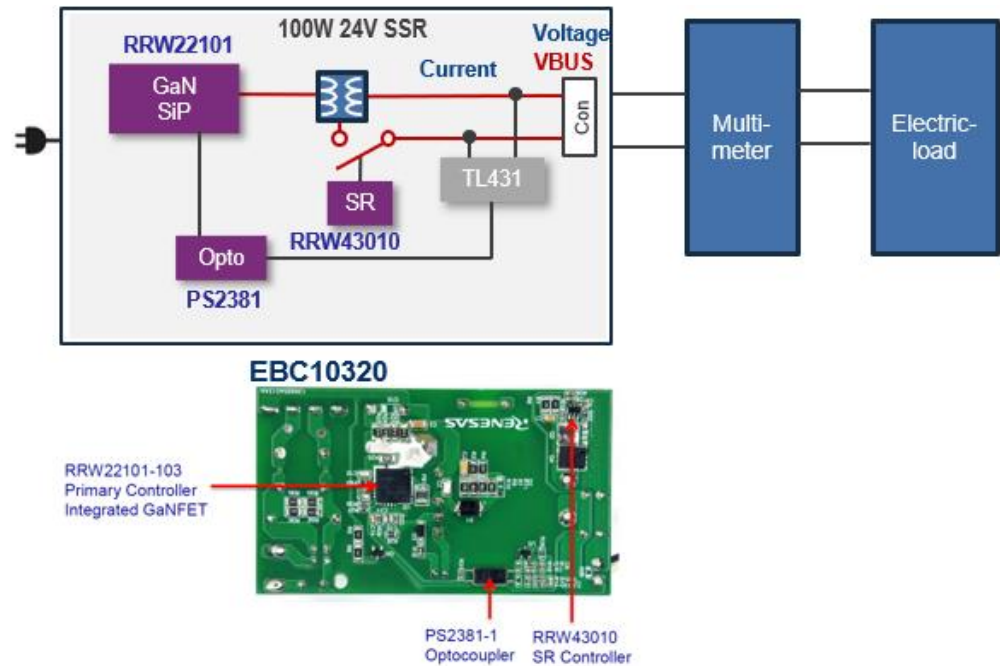

EBC 10320: 100W/24V Adaptor

- AC input range: 90-264 VAC
- DC output: 24V/4.17A

Figure 1. EBC10320 Evaluation Board

2. Equipment and Setup

2.1 Recommended Equipment

- An AC Power supply capable of generating AC voltage from 90V to 264V at 60Hz/50Hz, with at least 3A output current capability.
- An E-load or a load resistor box with an adjustable value of 5.8Ω and up, or an electronic load that can emulate a resistor load or current load up to 4.17A for 24V output.
- Multimeters to measure the output voltage and current.
- Power meter to measure the AC input power.

2.2 Setup and Operation

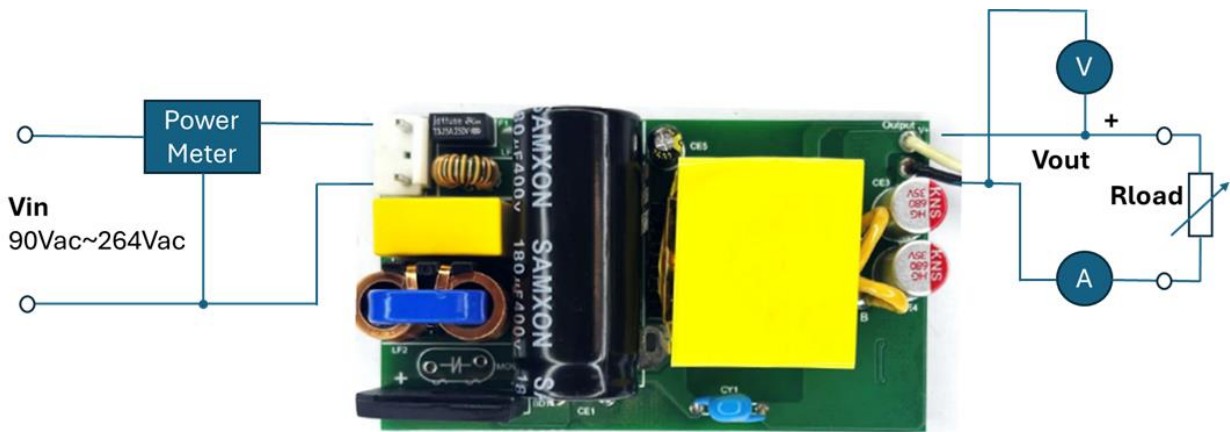

Figure 2. EBC10320 Connection Diagram

1. Program the AC power supply with a voltage between 90V and 264V at the corresponding frequency of 60Hz or 50Hz.
2. While the AC power supply is off, connect the output cables of the AC power supply to the L and N terminal of the EBC10320 evaluation board. An optional power meter can be added in between the AC power supply output and input of the board.
3. Connect the corresponding load to the output terminals of the EBC10320 evaluation board: 24V VOUT to GND.
4. Connect a voltage meter to VOUT and GND, and connect a current meter between the board outputs and the load.
5. Turn on the AC power supply and start to measure the electrical data.

3. System Power Off

Before powering off the system, read the following important operational note.

Important: Due to large capacitors in the EBC10320 evaluation board, the board requires a long time to power off. Do not take out the module from the box and touch it.

4. Ordering Information

Part Number	Description
EBC10320	EBC10320 Evaluation Board

5. Revision History

Revision	Date	Description
1.00	Apr 1, 2026	Initial release.