

## ISL73849SLH

LDR TID Test Results for the Rad Hard Single-/Dual-Phase Current Mode PWM Controller w/ PMBus & Telemetry

### Introduction

This report documents the results of low dose rate (LDR) total dose testing of the ISL73849SLH PMBus based synchronous buck controller. The testing was conducted to provide an assessment of the low dose total dose hardness of the parts and to determine any bias sensitivity. Parts were irradiated under bias and with all pins grounded - at LDR to 100krad(Si). The ISL73849SLH is rated at 75krad(Si) at LDR (0.01rad(Si)/s) and is acceptance-tested on a wafer by wafer basis to the datasheet limits.

### Product Description

The ISL73849SLH is a PMBus-based synchronous buck controller that can operate as a single or dual-phase controller. It is intended to work with the ISL73041SLHM (half bridge GaN FET driver) to generate Point-Of-Load voltage rails for commercial space applications.

It accepts an input voltage range of 4.5V to 19V with a programmable output switching frequency between 250kHz and 1.5MHz with a single resistor. The output can regulate a voltage upwards of 200mV and is limited on the top end by the minimum off time and selected switching frequency.

The wide input voltage range makes it a suitable power supply option for a high current FPGA core and other general-purpose power solutions. The ISL73849SLH uses current-mode modulation, which simplifies loop compensation and provides excellent power supply rejection. Additionally, the output is remotely sensed to compensate for any voltage drop in the load conditions. All of this put together results in a robust power supply solution that requires minimal components while achieving high current density.

The ISL73849SLH also features a tri-level output that provides excellent protection against faults by driving a mid scale voltage to signal the power stage to enter a Hi-Z condition. Control, Telemetry and Fault Reporting through PMBus makes the ISL73849SLH easy to program using an MCU.

The ISL73849SLH operates across the military temperature range from -55°C to +125°C and is available in a 24-pin hermetically sealed Ceramic Dual Flatpack (CDFP) package or die form. The pin assignments are shown in [Figure 1](#).

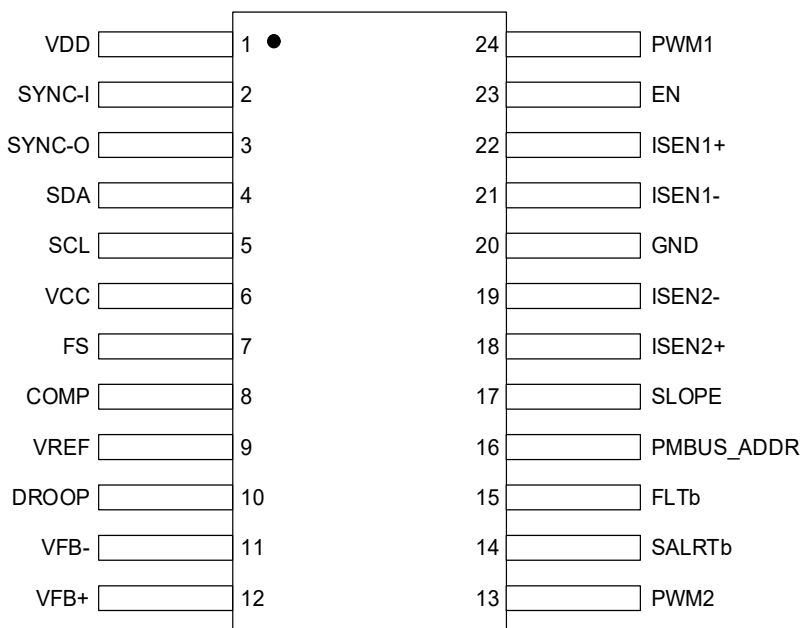

Figure 1. 24-Pin Ceramic Dual Flatpack (CDFP) Pin Assignments - Top View

## Related Literature

For a full list of related documents, visit our website:

- [ISL73849SLH](#) device page
- MIL-STD-883 Test Method 1019

<b>1. Test Description</b>	<b>3</b>
1.1 Irradiation Facilities	3
1.2 Test Fixturing	3
1.3 Characterization Equipment and Procedures	3
1.4 Experimental Matrix	3
1.5 Downpoints	3
<b>2. Test Results</b>	<b>4</b>
2.1 Attributes Data	4
2.2 Key Parameter Variables Data	4
<b>3. Discussion and Conclusion</b>	<b>66</b>
<b>4. Revision History</b>	<b>66</b>
<b>A. Reported Parameters</b>	<b>67</b>

# 1. Test Description

## 1.1 Irradiation Facilities

LDR testing was performed at 0.01rad(Si)/s using the Renesas Palm Bay Hopewell Designs N40 panoramic irradiator. PbAl spectrum hardening filters were used to shield the test board and devices under test against low energy secondary gamma radiation. Half of the samples were biased, and half had all pins grounded during irradiation.

## 1.2 Test Fixturing

Figure 2 shows the configuration and voltages used for biased irradiation.

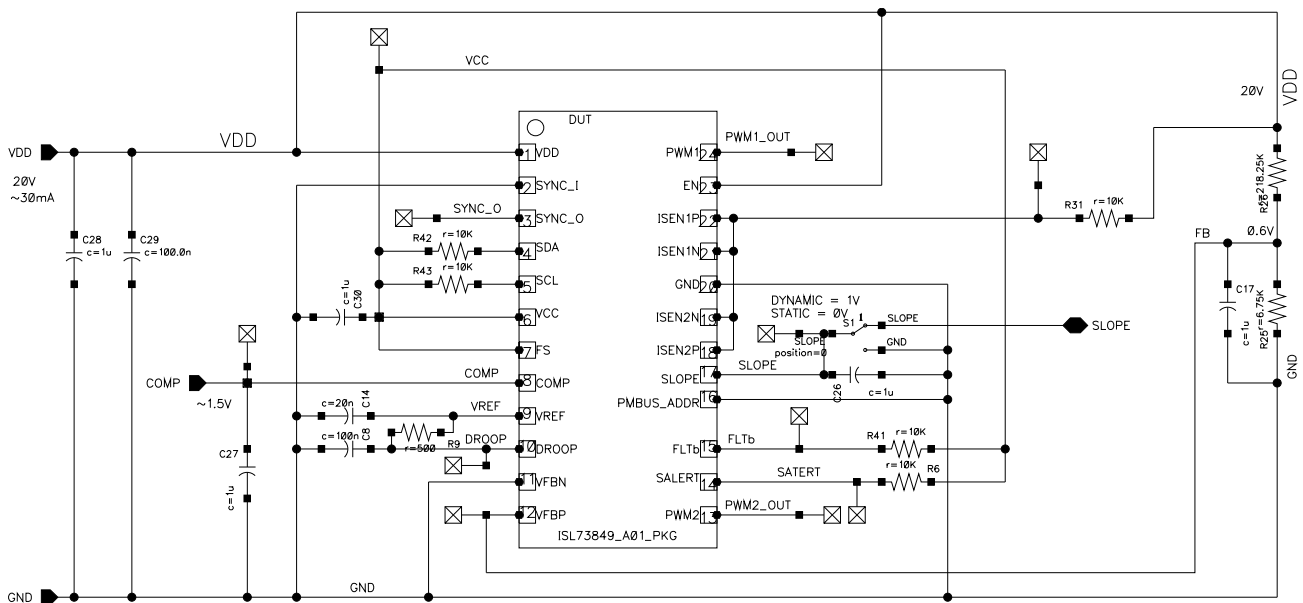

Figure 2. ISL73849SLH TID Bias Schematic and Bias Voltages

## 1.3 Characterization Equipment and Procedures

All electrical testing was performed at room temperature outside the irradiator, using production automated test equipment (ATE) with data-logging at each down-point.

## 1.4 Experimental Matrix

Irradiation was performed in accordance with the guidelines of MIL-STD-883 Test Method 1019. The experimental matrix consisted of 10 samples irradiated at LDR under bias and 10 samples irradiated at LDR with all pins grounded. Six control units were used.

The 20 ISL73849SLH samples were drawn from Lots F6XM27, F6XM28, and F6XM49. Samples were packaged in the 24Ld CDFP.

## 1.5 Downpoints

Downpoints for the LDR tests were 0, 10, 30, 50, 75, and 100krad(Si).

## 2. Test Results

LDR TID testing of the ISL73849SLH is complete and the results are reported in the balance of this report.

### 2.1 Attributes Data

All tested parameters passed the datasheet limits. [Table 1](#) summarizes the results.

**Table 1. Total Dose Test Attributes Data**

Dose Rate (rad(Si)/s)	Bias	Sample Size	Downpoint	Pass <sup>[1]</sup>	Fail
0.01	Biased (Figure 2)	10	Pre-irradiation	10	-
			10krad(Si)	10	0
			30krad(Si)	10	0
			50krad(Si)	10	0
			75krad(Si)	10	0
			100krad(Si)	10	0
0.01	Grounded	10	Pre-irradiation	10	-
			10krad(Si)	10	0
			30krad(Si)	10	0
			50krad(Si)	10	0
			75krad(Si)	10	0
			100krad(Si)	10	0

1. A Pass indicates a sample that passes all post-radiation datasheet limits.

### 2.2 Key Parameter Variables Data

The plots in [Figure 3](#) through [Figure 124](#) illustrate the LDR response of the selected parameters shown in [Table 2](#) in the Appendix. The plots show the average tested values of the parameters as a function of total dose for each of the irradiation conditions, biased and grounded. The plots also include error bars at each down-point, representing the minimum and maximum measured values of the samples, although in some plots the error bars may not be visible due to their values compared to the scale of the graph. The ISL73849SLH is rated at 75krad(Si) at LDR.

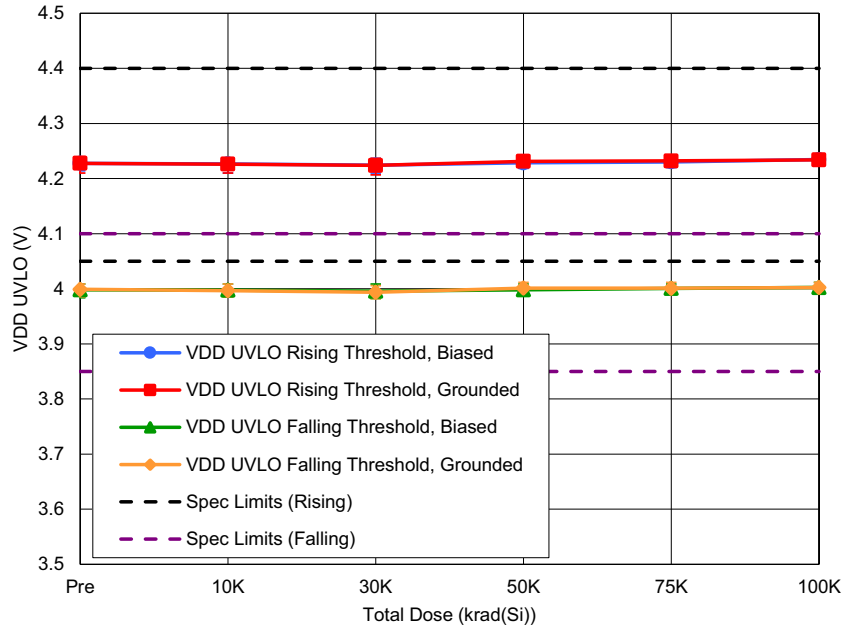

Figure 3. Average rising and falling  $V_{DD}$  UVLO with  $V_{DD} = 19V$  and  $EN = 3.3V$ , as a function of LDR irradiation. The error bars represent the minimum and maximum measured values. The post-radiation datasheet limits are 4.05V minimum and 4.4V maximum rising and 3.85V minimum and 4.10V maximum falling

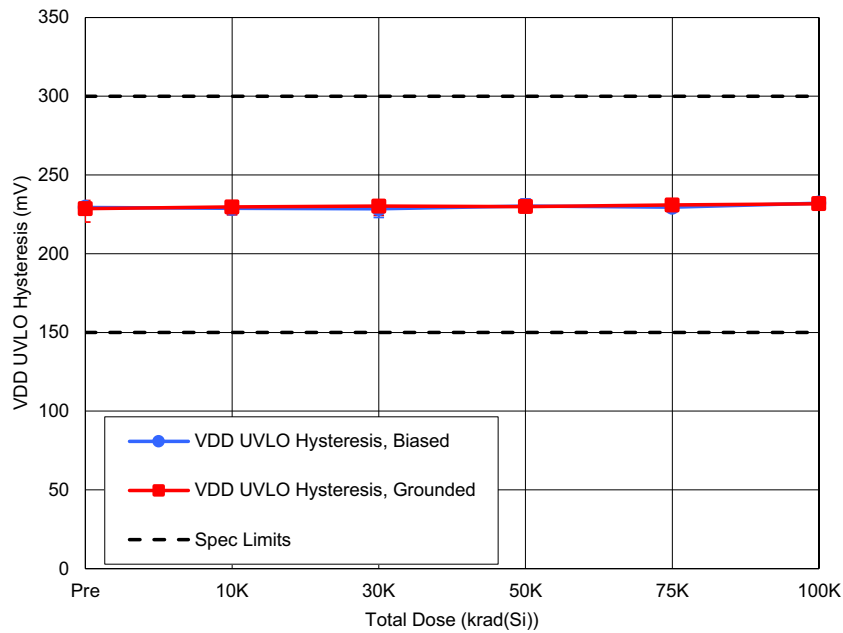

Figure 4. Average  $V_{DD}$  UVLO Hysteresis with  $V_{DD} = 19V$  and  $EN = 3.3V$ , as a function of LDR irradiation. The error bars represent the minimum and maximum measured values. The post-radiation datasheet limits are 150mV minimum and 300mV maximum.

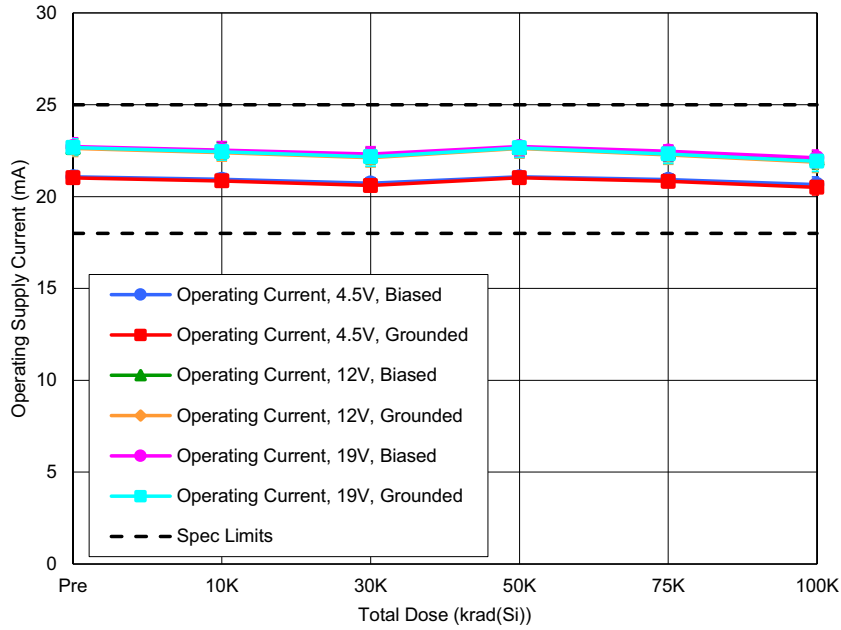

Figure 5. Average operating supply current with  $V_{DD} = 4.5V, 12V$  and  $19V$ ;  $EN = 3.3V, f_{SW} = 500kHz$ , and  $C_L = 100pF$ , as a function of LDR irradiation. The error bars represent the minimum and maximum measured values. The post-radiation datasheet limits are  $18mA$  minimum and  $25mA$  maximum.

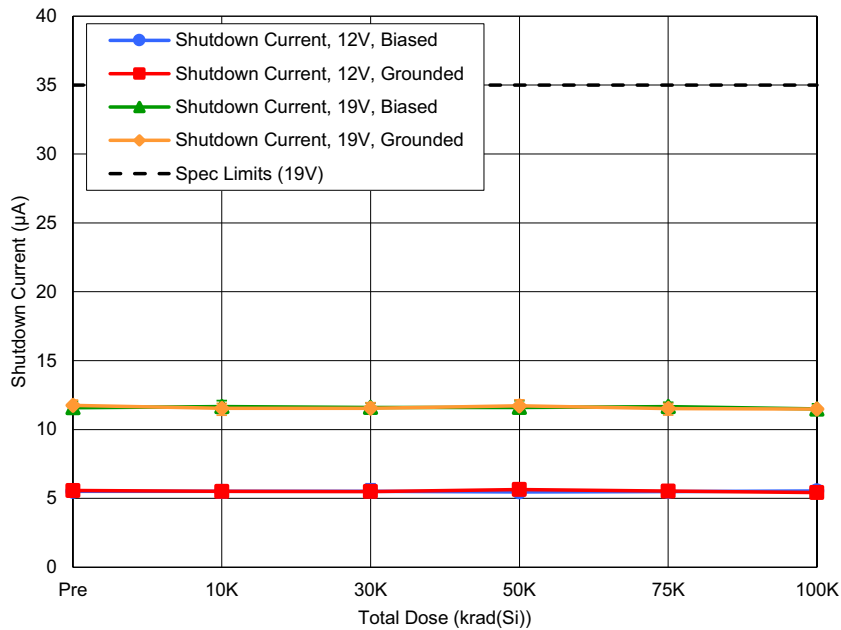

Figure 6. Average shutdown supply current with  $V_{DD} = 12V$  and  $19V$ ;  $EN = GND$ , as a function of LDR irradiation. The error bars represent the minimum and maximum measured values. The post-radiation datasheet limit is  $35\mu A$  maximum.

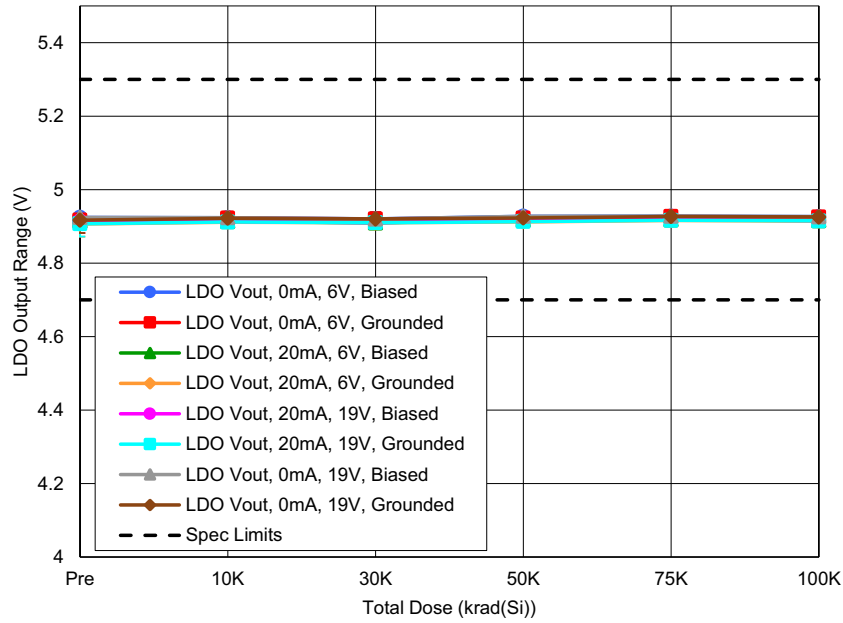

Figure 7. Average internal LDO output range with  $V_{DD} = 6V$  and  $19V$ ;  $I_{OUT} = 0mA$  and  $20mA$ , as a function of LDR irradiation. The error bars represent the minimum and maximum measured values. The post-radiation datasheet limit is  $4.7V$  minimum and  $5.3V$  maximum.

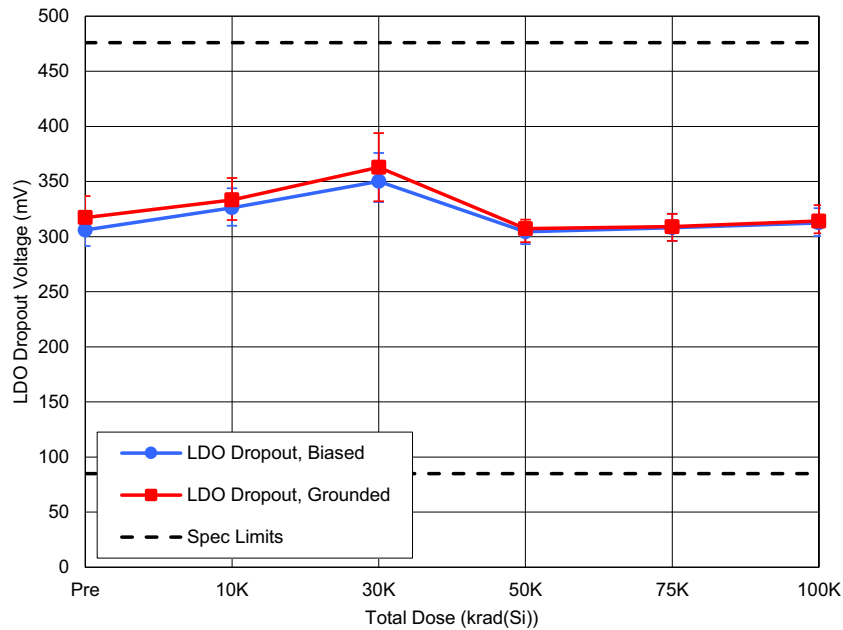

Figure 8. Average internal LDO dropout voltage with  $V_{DD} = 4.5V$  and  $I_{OUT} = 50mA$ , as a function of LDR irradiation. The error bars represent the minimum and maximum measured values. The post-radiation datasheet limit is  $85mV$  minimum and  $476mV$  maximum.

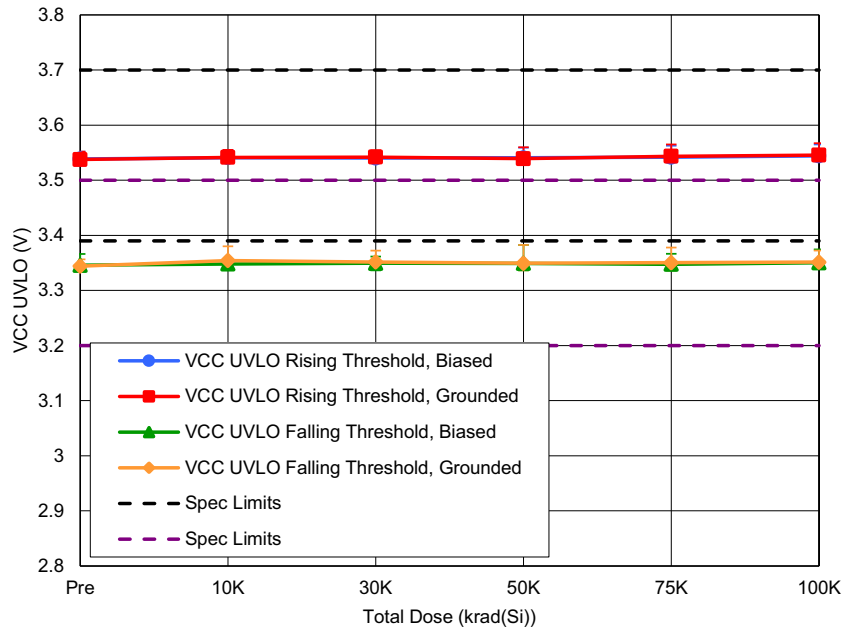

Figure 9. Average rising and falling  $V_{CC}$  UVLO with  $V_{DD} = 19V$  and  $EN = 3.3V$ , as a function of LDR irradiation. The error bars represent the minimum and maximum measured values. The post-radiation datasheet limits are 3.39V minimum and 3.70V maximum rising and 3.2V minimum and 3.5V maximum falling.

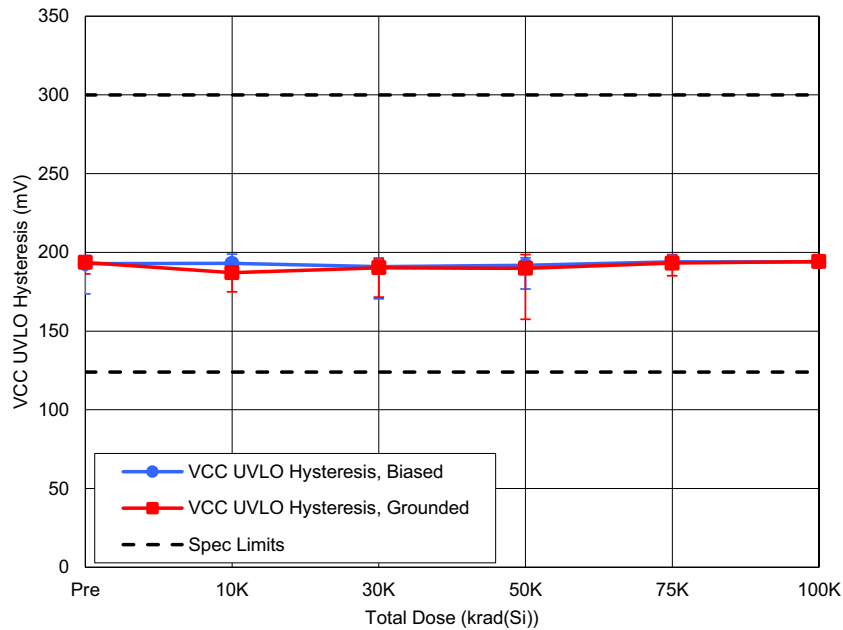

Figure 10. Average  $V_{CC}$  UVLO Hysteresis with  $V_{DD} = 19V$  and  $EN = 3.3V$ , as a function of LDR irradiation. The error bars represent the minimum and maximum measured values. The post-radiation datasheet limits are 124mV minimum and 300mV maximum.

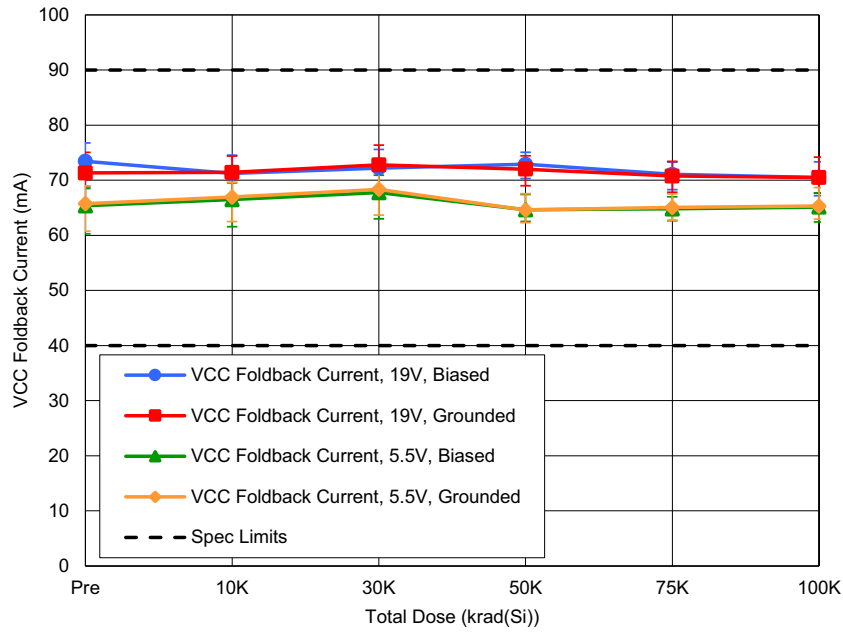

Figure 11. Average  $V_{CC}$  foldback current limit with  $V_{DD} = 5.5V$  and  $19V$ ,  $V_{CC} = 0V$  and  $EN = 1.6V$ , as a function of LDR irradiation. The error bars represent the minimum and maximum measured values. The post-radiation datasheet limits are 40mA minimum and 90mA maximum.

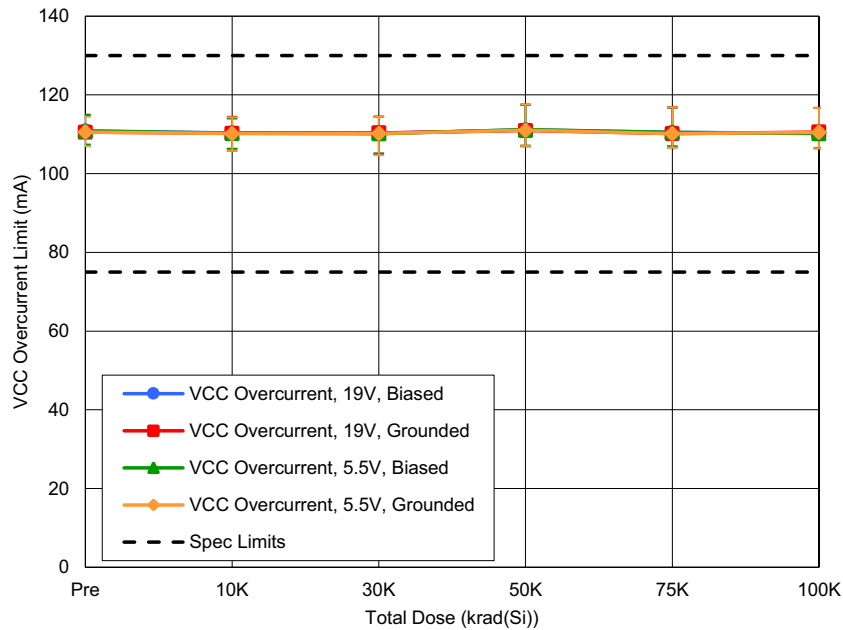

Figure 12. Average  $V_{CC}$  overcurrent limit with  $V_{DD} = 5.5V$  and  $19V$ ,  $V_{CC} = 4.3V$  and  $EN = 1.6V$ , as a function of LDR irradiation. The error bars represent the minimum and maximum measured values. The post-radiation datasheet limits are 75mA minimum and 130mA maximum.

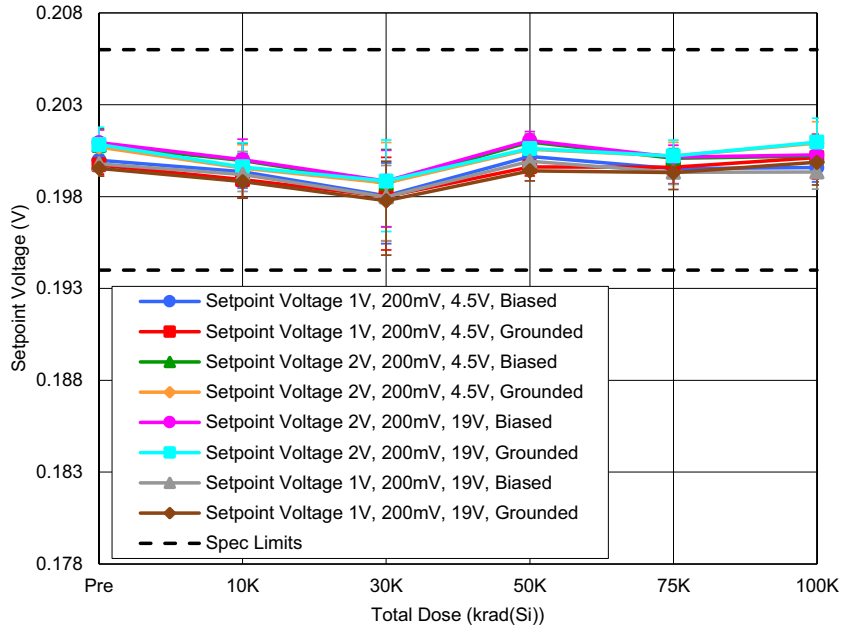

Figure 13. Average set point voltage with  $V_{DD} = 4.5V$  and  $19V$ ,  $V_{REF} = V_{DROOP} = 1V$  and  $2V$ ,  $V_{SEN1} = V_{SEN2} = 0mV$  and PMBus command set for  $200mV$ , as a function of LDR irradiation. The error bars represent the minimum and maximum measured values. The post-radiation datasheet limits are  $0.194V$  minimum and  $0.206V$  maximum.

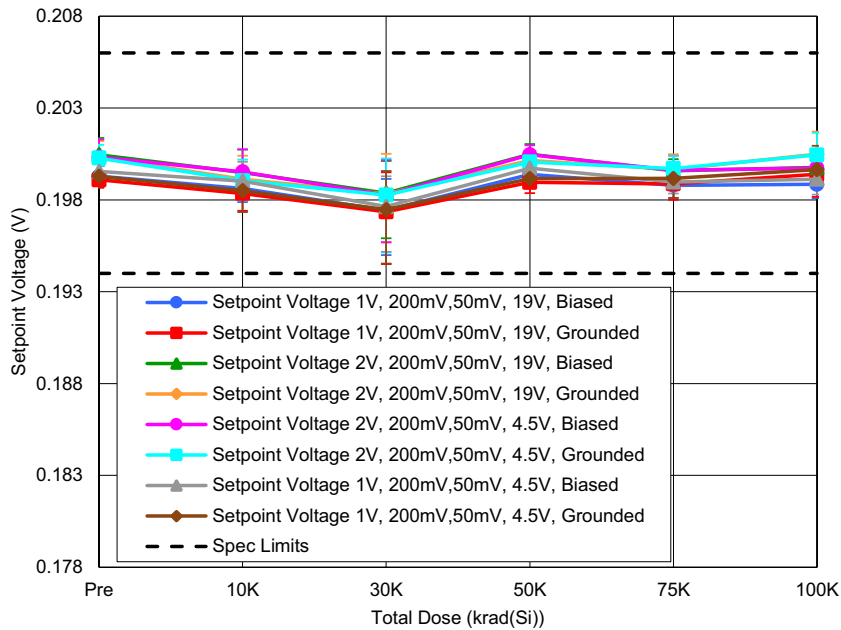

Figure 14. Average set point voltage with  $V_{DD} = 4.5V$  and  $19V$ ,  $V_{REF} = V_{DROOP} = 1V$  and  $2V$ ,  $V_{SEN1} = V_{SEN2} = 50mV$  and PMBus command set for  $200mV$ , as a function of LDR irradiation. The error bars represent the minimum and maximum measured values. The post-radiation datasheet limits are  $0.194V$  minimum and  $0.206V$  maximum.

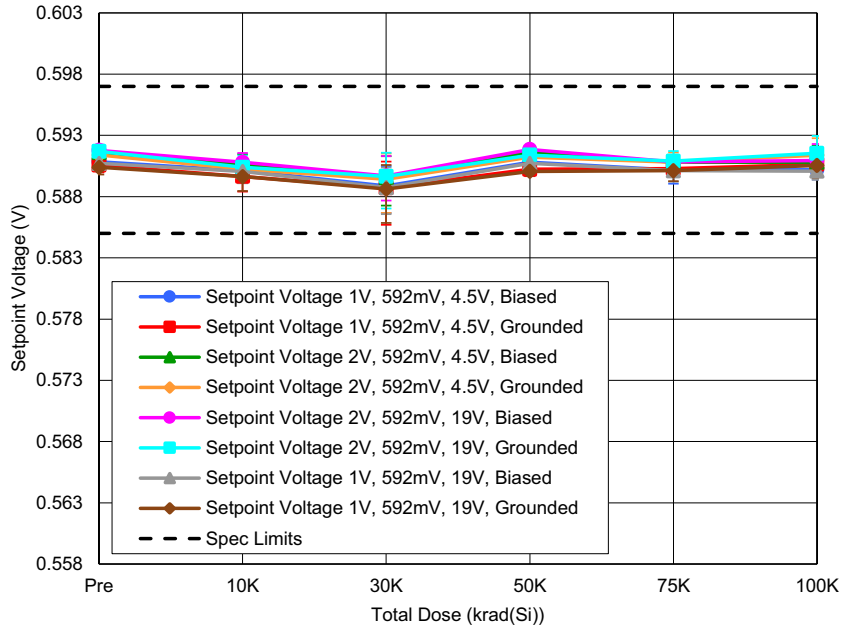

Figure 15. Average set point voltage with  $V_{DD} = 4.5V$  and  $19V$ ,  $V_{REF} = V_{DROOP} = 1V$  and  $2V$ ,  $V_{SEN1} = V_{SEN2} = 0mV$  and PMBus command set for  $592mV$  on power up or enable, as a function of LDR irradiation. The error bars represent the minimum and maximum measured values. The post-radiation datasheet limits are  $0.585V$  minimum and  $0.597V$  maximum.

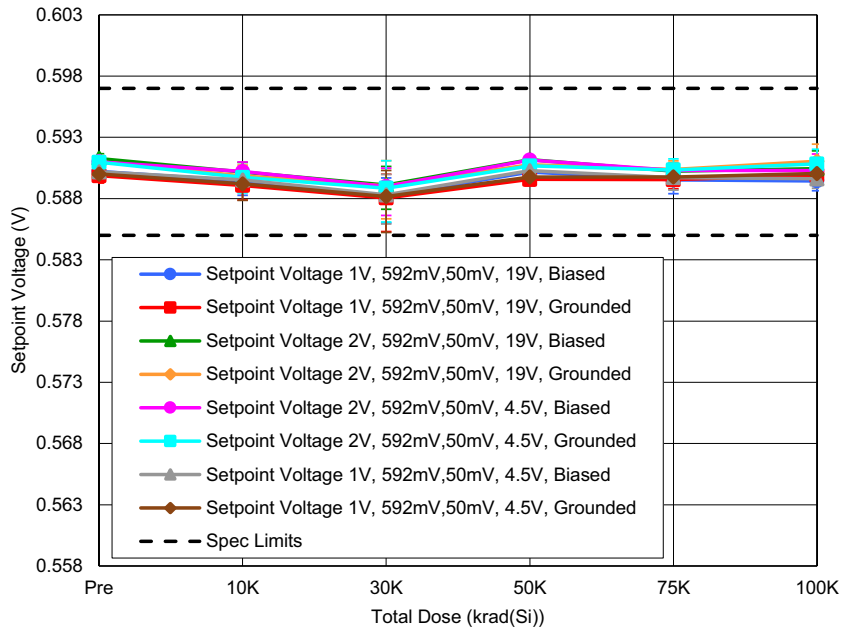

Figure 16. Average set point voltage with  $V_{DD} = 4.5V$  and  $19V$ ,  $V_{REF} = V_{DROOP} = 1V$  and  $2V$ ,  $V_{SEN1} = V_{SEN2} = 50mV$  and PMBus command set for  $592mV$  on power up or enable, as a function of LDR irradiation. The error bars represent the minimum and maximum measured values. The post-radiation datasheet limits are  $0.585V$  minimum and  $0.597V$  maximum.

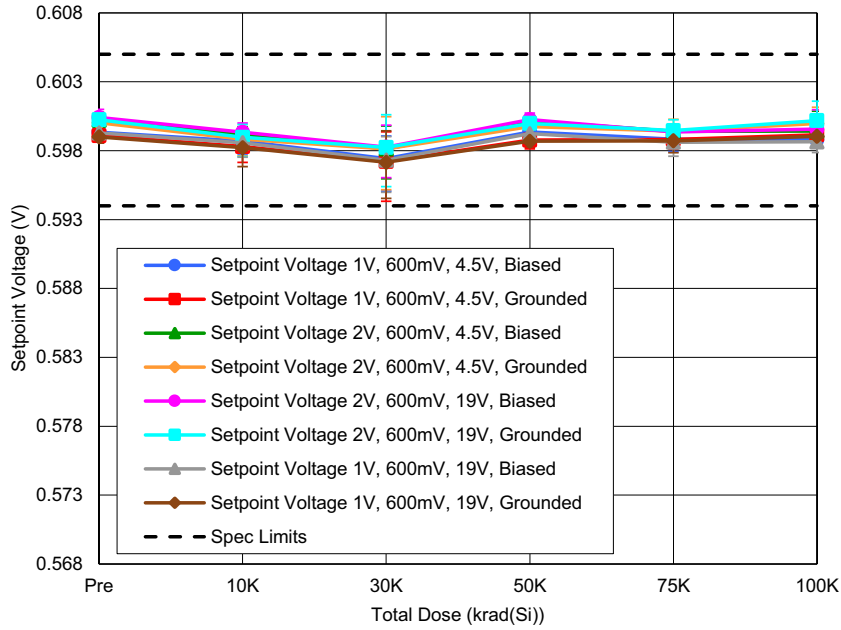

Figure 17. Average set point voltage with  $V_{DD} = 4.5V$  and  $19V$ ,  $V_{REF} = V_{DROOP} = 1V$  and  $2V$ ,  $V_{SEN1} = V_{SEN2} = 0mV$  and PMBus command set for  $600mV$ , as a function of LDR irradiation. The error bars represent the minimum and maximum measured values. The post-radiation datasheet limits are  $0.594V$  minimum and  $0.605V$  maximum.

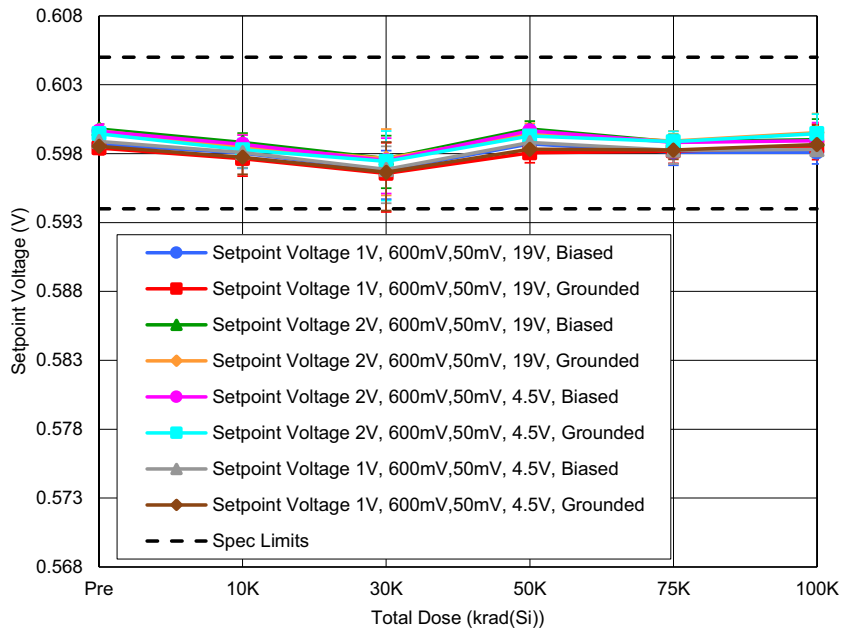

Figure 18. Average set point voltage with  $V_{DD} = 4.5V$  and  $19V$ ,  $V_{REF} = V_{DROOP} = 1V$  and  $2V$ ,  $V_{SEN1} = V_{SEN2} = 50mV$  and PMBus command set for  $600mV$ , as a function of LDR irradiation. The error bars represent the minimum and maximum measured values. The post-radiation datasheet limits are  $0.594V$  minimum and  $0.605V$  maximum.

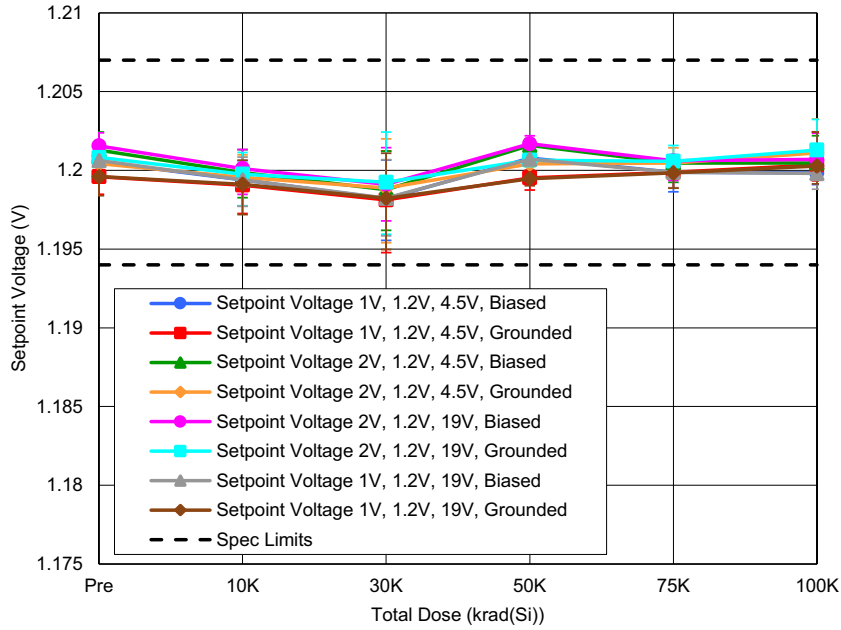

Figure 19. Average set point voltage with  $V_{DD} = 4.5V$  and  $19V$ ,  $V_{REF} = V_{DROOP} = 1V$  and  $2V$ ,  $V_{SEN1} = V_{SEN2} = 0mV$  and PMBus command set for  $1.2V$ , as a function of LDR irradiation. The error bars represent the minimum and maximum measured values. The post-radiation datasheet limits are  $1.194V$  minimum and  $1.207V$  maximum.

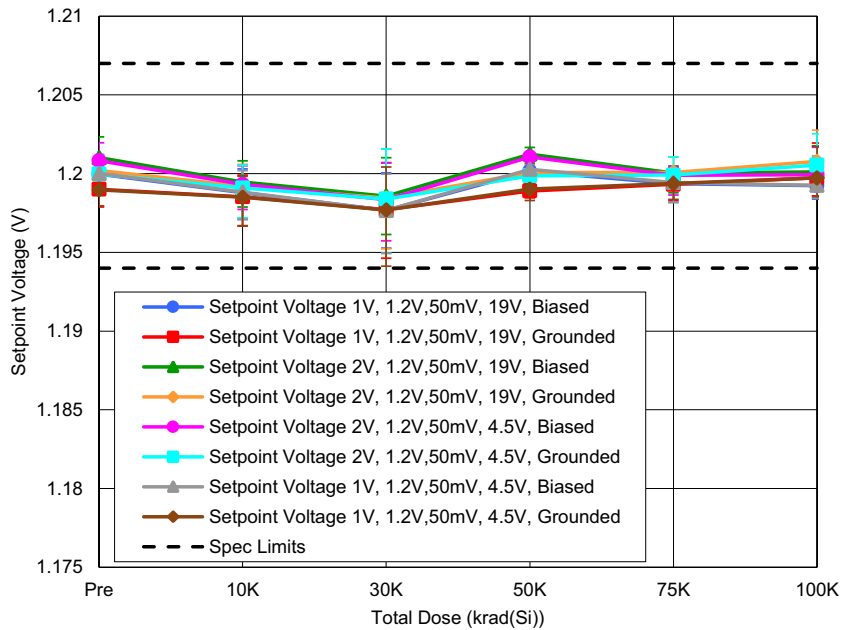

Figure 20. Average set point voltage with  $V_{DD} = 4.5V$  and  $19V$ ,  $V_{REF} = V_{DROOP} = 1V$  and  $2V$ ,  $V_{SEN1} = V_{SEN2} = 50mV$  and PMBus command set for  $1.2V$ , as a function of LDR irradiation. The error bars represent the minimum and maximum measured values. The post-radiation datasheet limits are  $1.194V$  minimum and  $1.207V$  maximum.

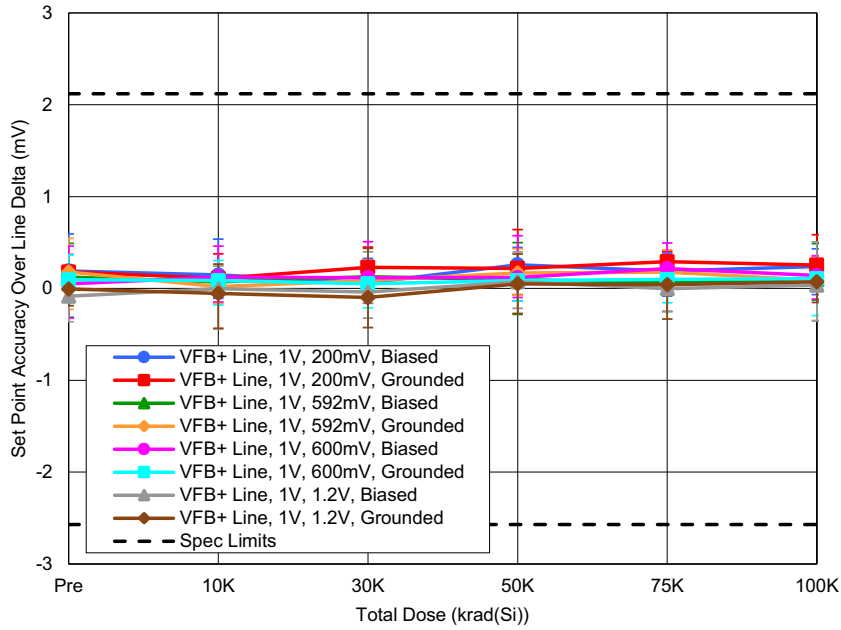

Figure 21. Average set point accuracy over line delta with  $V_{REF} = V_{DROOP} = 1V$ , as a function of LDR irradiation. The error bars represent the minimum and maximum measured values. The post-radiation datasheet limits are -2.57mV minimum and 2.12mV maximum.

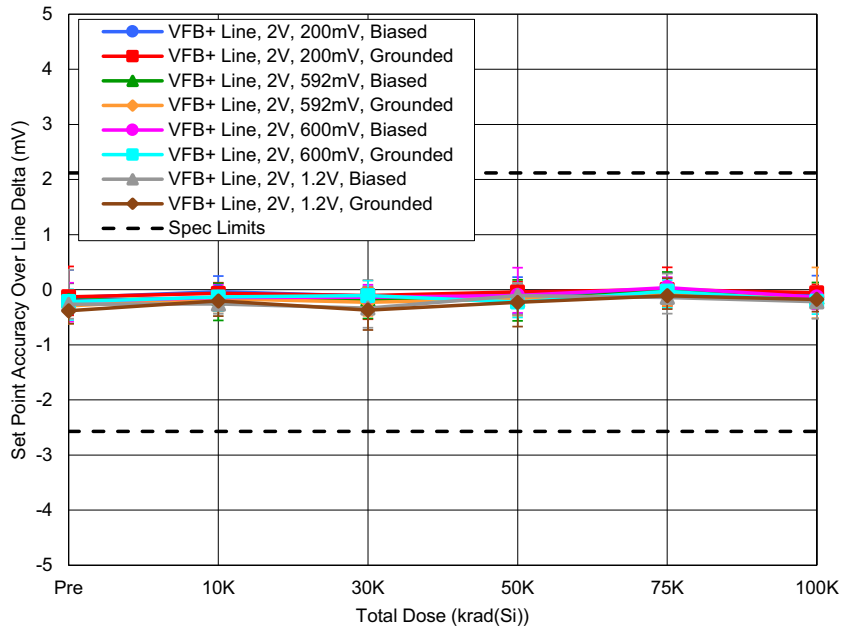

Figure 22. Average set point accuracy over line delta with  $V_{REF} = V_{DROOP} = 2V$ , as a function of LDR irradiation. The error bars represent the minimum and maximum measured values. The post-radiation datasheet limits are -2.57mV minimum and 2.12mV maximum.

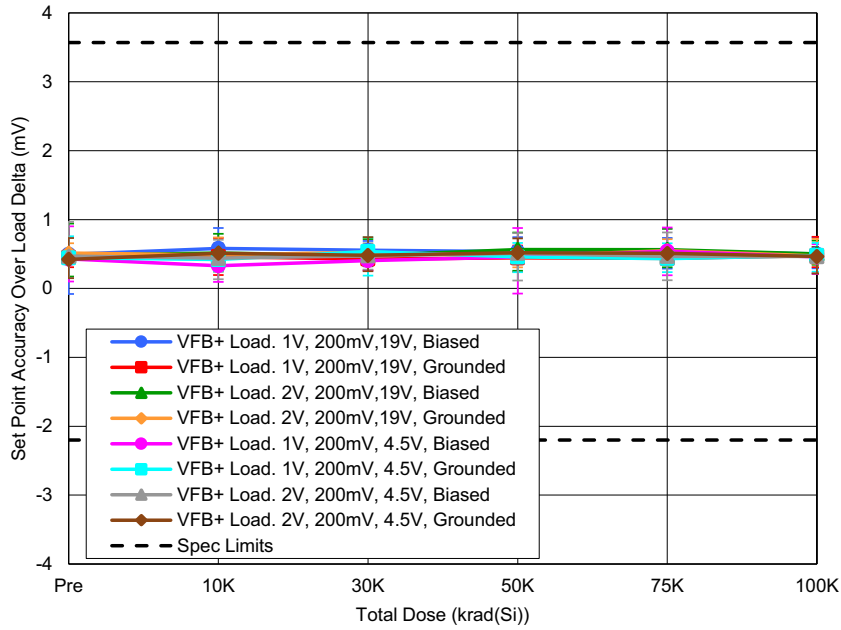

Figure 23. Average set point accuracy over load delta with  $V_{DD} = 4.5V, 19V$ ,  $V_{REF} = V_{DROOP} = 1V, 2V$  and PMBus command set for 200mV, as a function of LDR irradiation. The error bars represent the minimum and maximum measured values. The post-radiation datasheet limits are -2.2mV minimum and 3.57mV maximum.

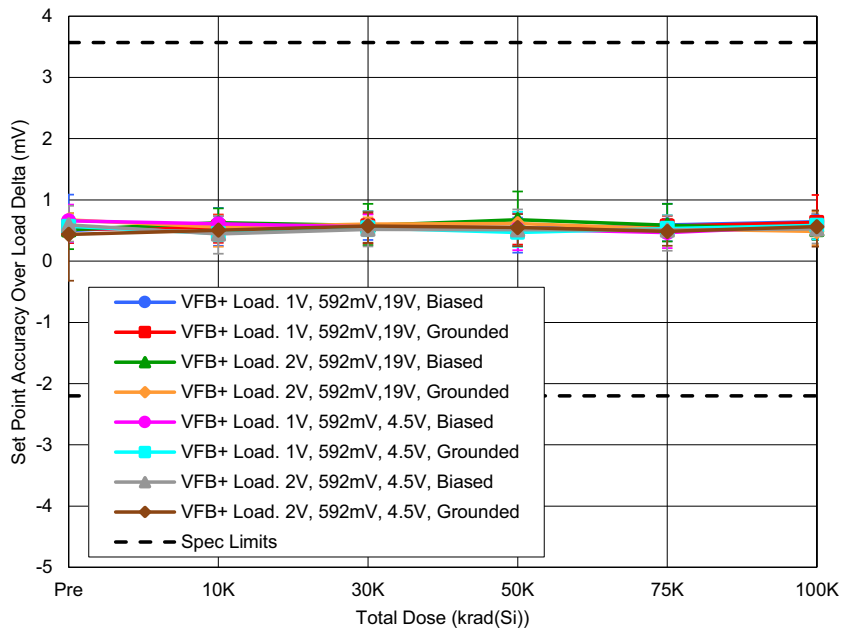

Figure 24. Average set point accuracy over load delta with  $V_{DD} = 4.5V, 19V$ ,  $V_{REF} = V_{DROOP} = 1V, 2V$  and PMBus command set for 592mV, as a function of LDR irradiation. The error bars represent the minimum and maximum measured values. The post-radiation datasheet limits are -2.2mV minimum and 3.57mV maximum.

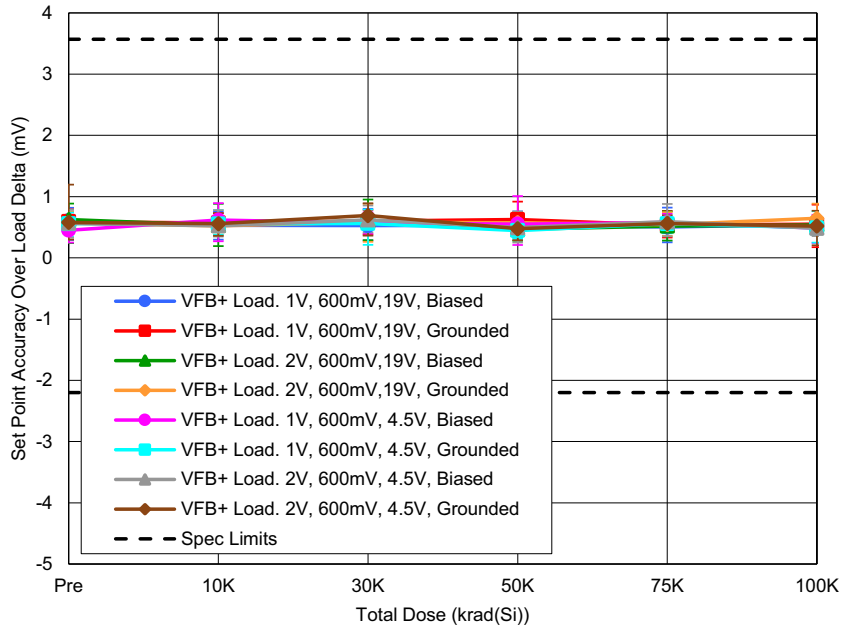

Figure 25. Average set point accuracy over load delta with  $V_{DD} = 4.5V, 19V$ ,  $V_{REF} = V_{DROOP} = 1V, 2V$  and PMBus command set for 600mV, as a function of LDR irradiation. The error bars represent the minimum and maximum measured values. The post-radiation datasheet limits are -2.2mV minimum and 3.57mV maximum.

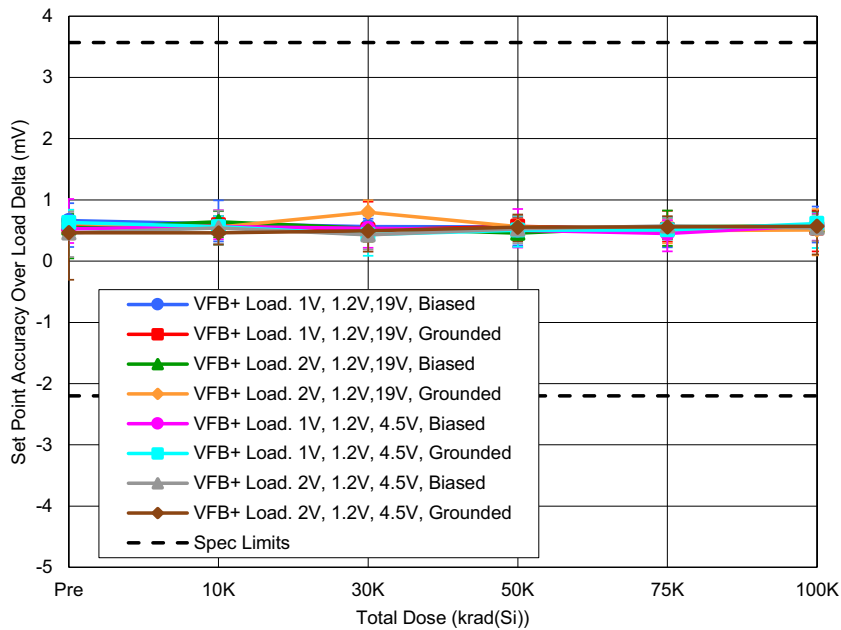

Figure 26. Average set point accuracy over load delta with  $V_{DD} = 4.5V, 19V$ ,  $V_{REF} = V_{DROOP} = 1V, 2V$  and PMBus command set for 1.2V, as a function of LDR irradiation. The error bars represent the minimum and maximum measured values. The post-radiation datasheet limits are -2.2mV minimum and 3.57mV maximum.

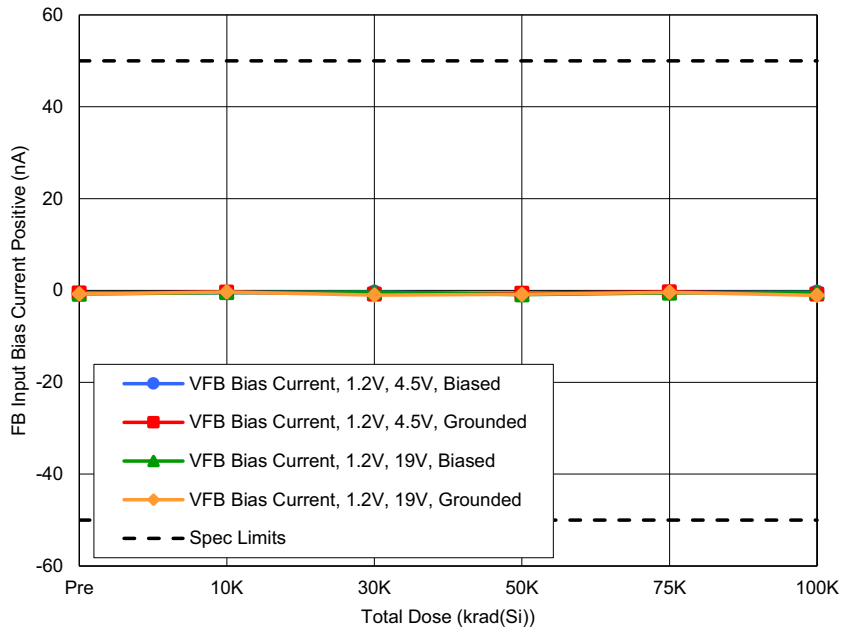

Figure 27. Average FB positive input bias current with  $V_{DD} = 4.5V, 19V$ , as a function of LDR irradiation. The error bars represent the minimum and maximum measured values. The post-radiation datasheet limits are  $-50nA$  minimum and  $50nA$  maximum.

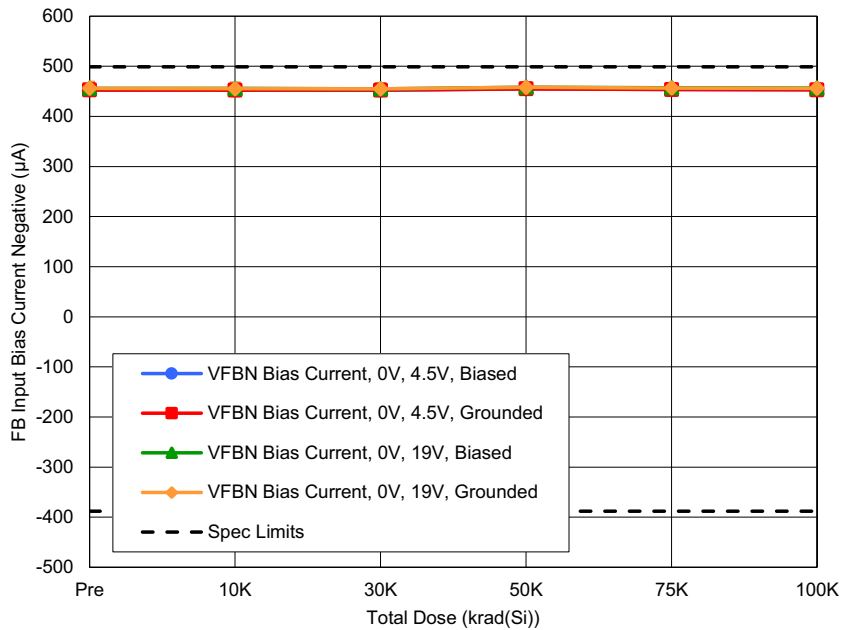

Figure 28. Average FB negative input bias current with  $V_{DD} = 4.5V, 19V$ , as a function of LDR irradiation. The error bars represent the minimum and maximum measured values. The post-radiation datasheet limits are  $-388\mu A$  minimum and  $499\mu A$  maximum.

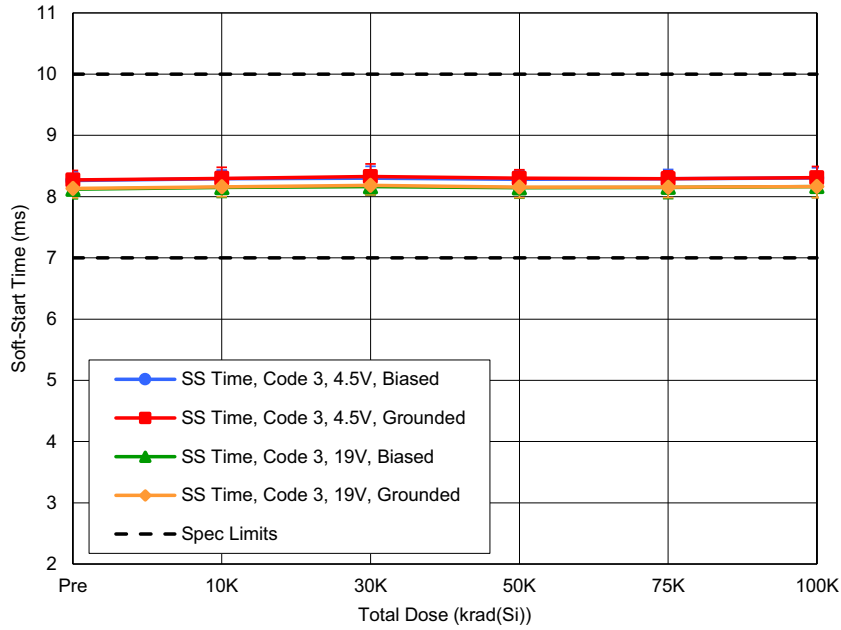

Figure 29. Average soft-start time with  $V_{DD} = 4.5V, 19V$ , PMBus command set for code 3, as a function of LDR irradiation. The error bars represent the minimum and maximum measured values. The post-radiation datasheet limits are 7ms minimum and 10ms maximum.

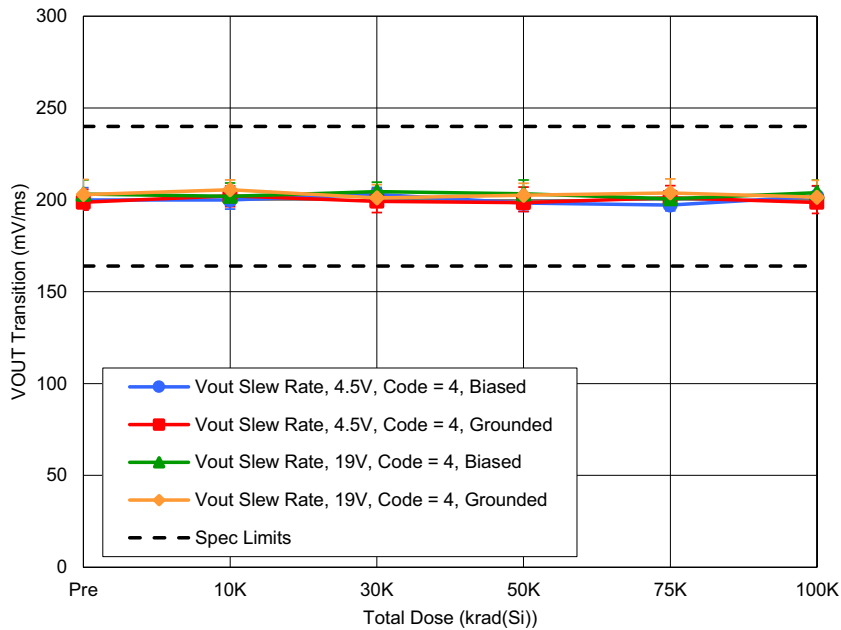

Figure 30. Average  $V_{OUT}$  transition time with  $V_{DD} = 4.5V, 19V$ , PMBus command set for code 4, as a function of LDR irradiation. The error bars represent the minimum and maximum measured values. The post-radiation datasheet limits are 164mV/ms minimum and 240mV/ms maximum.

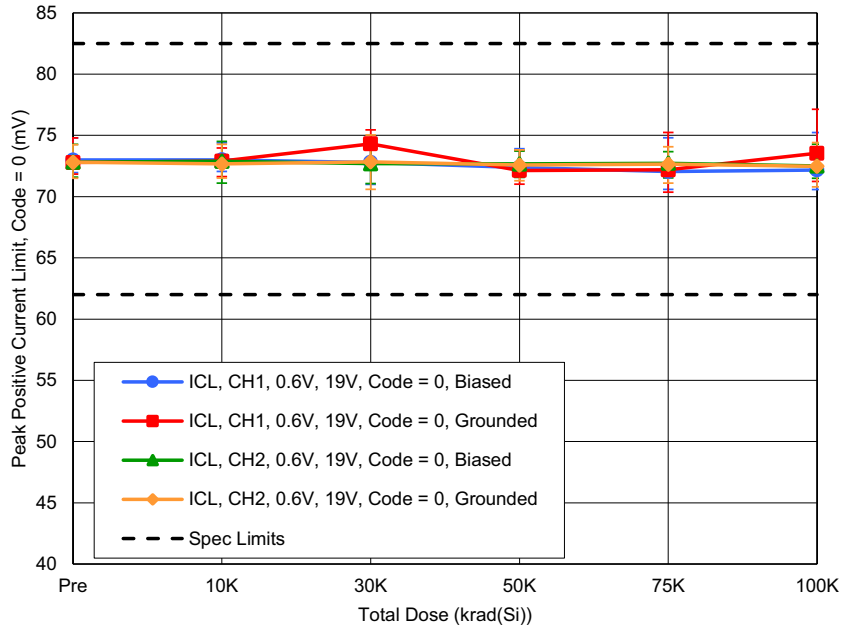

Figure 31. Average peak positive current limit with code = 0,  $V_{DD} = 19V$ ,  $V_{CM} = 0.6V$ , as a function of LDR irradiation. The error bars represent the minimum and maximum measured values. The post-radiation datasheet limits are 62mV minimum and 82.5mV maximum.

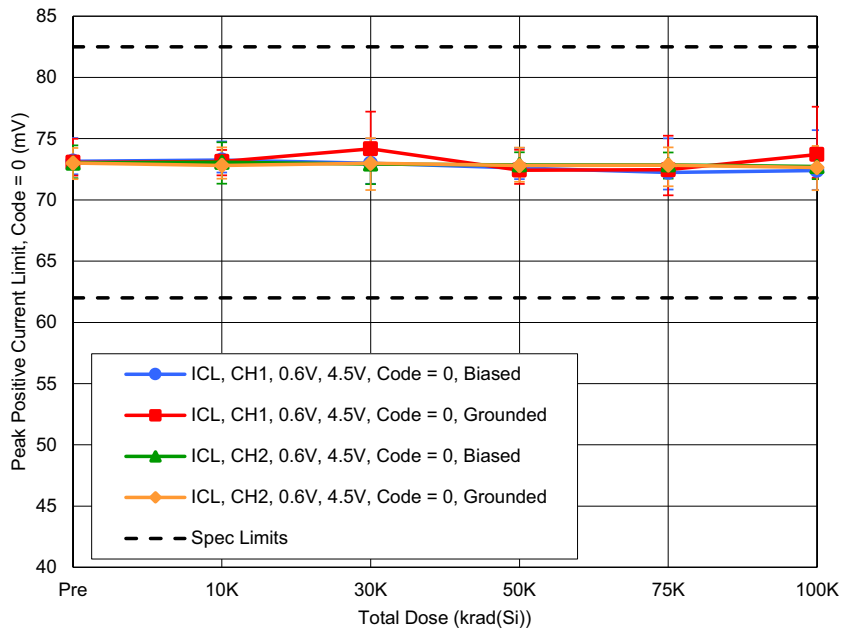

Figure 32. Average peak positive current limit with code = 0,  $V_{DD} = 4.5V$ ,  $V_{CM} = 0.6V$ , as a function of LDR irradiation. The error bars represent the minimum and maximum measured values. The post-radiation datasheet limits are 62mV minimum and 82.5mV maximum.

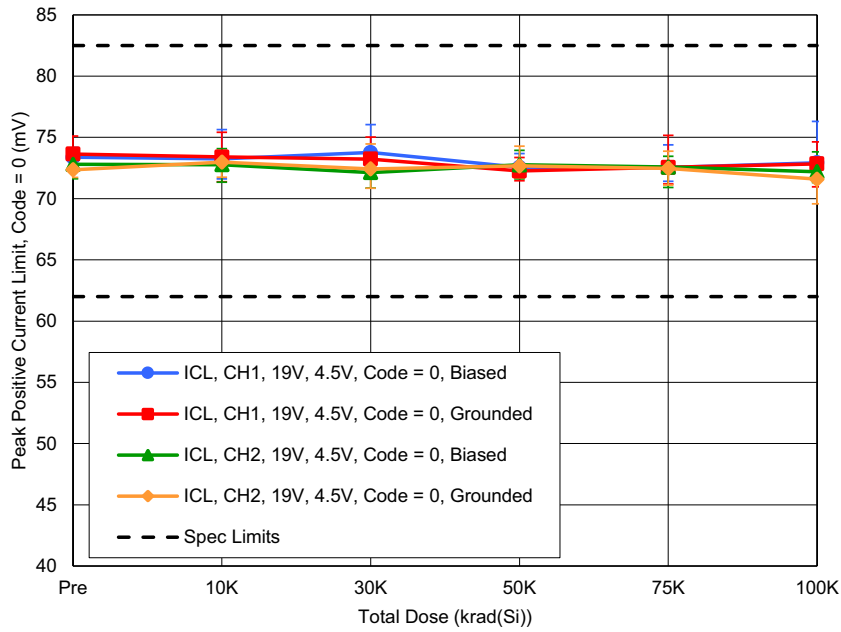

Figure 33. Average peak positive current limit with code = 0,  $V_{DD} = 4.5V$ ,  $V_{CM} = 19V$ , as a function of LDR irradiation. The error bars represent the minimum and maximum measured values. The post-radiation datasheet limits are 62mV minimum and 82.5mV maximum.

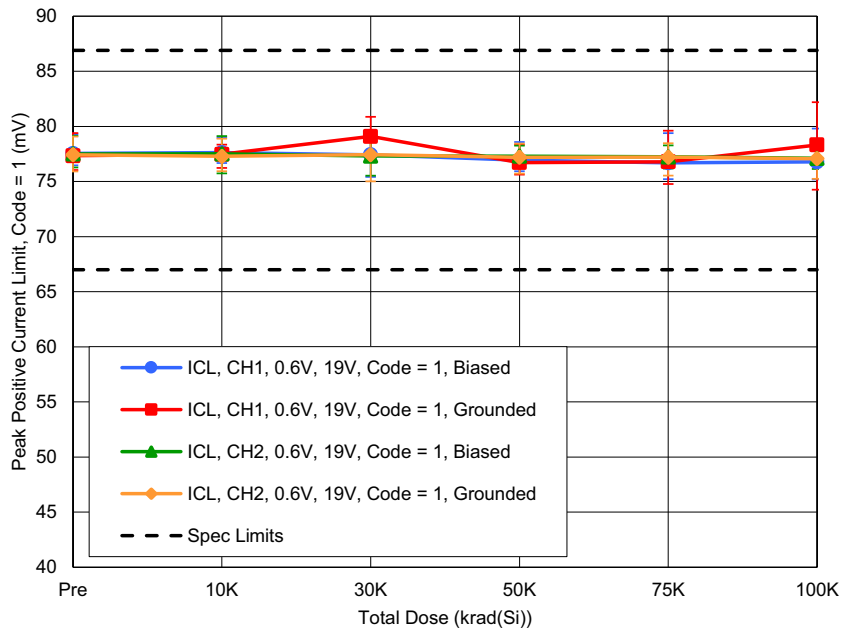

Figure 34. Average peak positive current limit with code = 1,  $V_{DD} = 19V$ ,  $V_{CM} = 0.6V$ , as a function of LDR irradiation. The error bars represent the minimum and maximum measured values. The post-radiation datasheet limits are 67mV minimum and 86.9mV maximum.

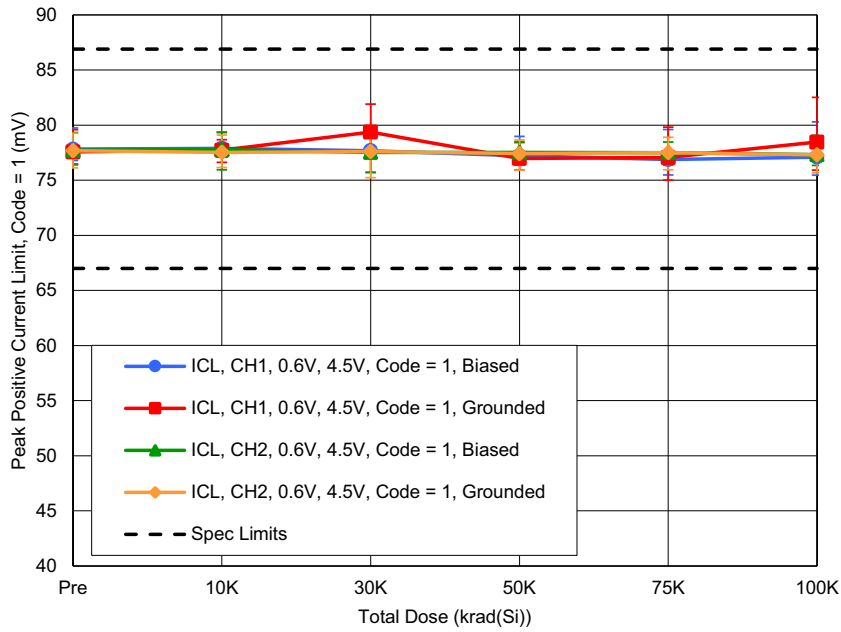

Figure 35. Average peak positive current limit with code = 1,  $V_{DD} = 4.5V$ ,  $V_{CM} = 0.6V$ , as a function of LDR irradiation. The error bars represent the minimum and maximum measured values. The post-radiation datasheet limits are 67mV minimum and 86.9mV maximum.

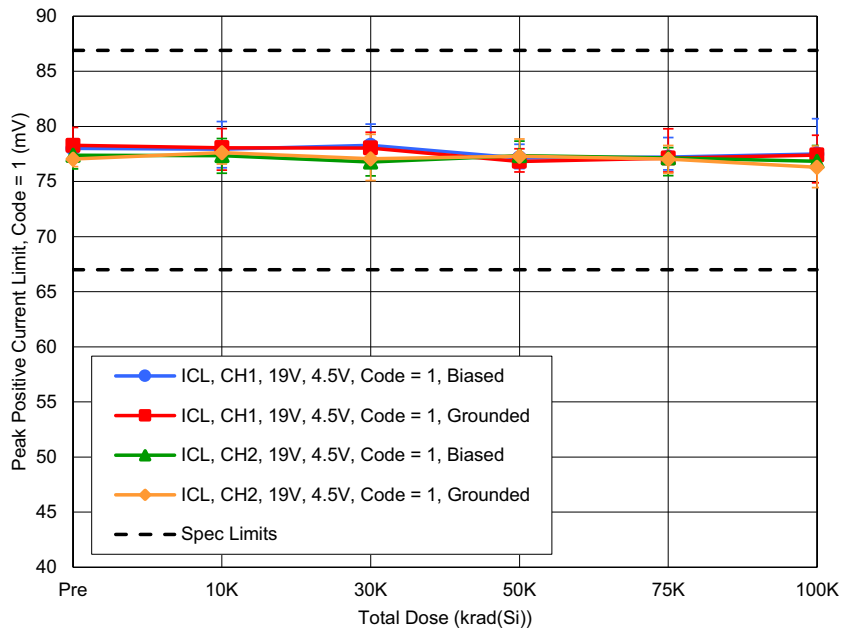

Figure 36. Average peak positive current limit with code = 1,  $V_{DD} = 4.5V$ ,  $V_{CM} = 19V$ , as a function of LDR irradiation. The error bars represent the minimum and maximum measured values. The post-radiation datasheet limits are 67mV minimum and 86.9mV maximum.

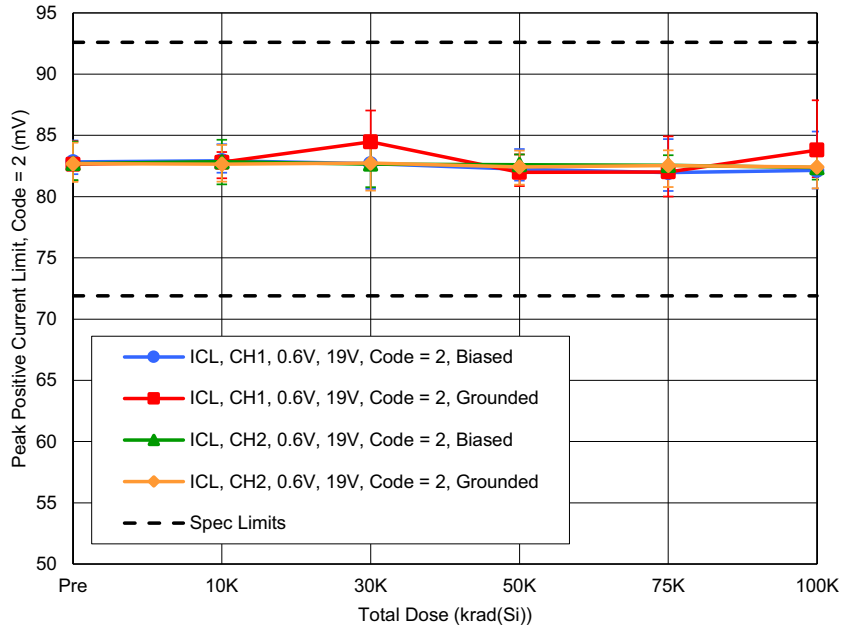

Figure 37. Average peak positive current limit with code = 2,  $V_{DD} = 19V$ ,  $V_{CM} = 0.6V$ , as a function of LDR irradiation. The error bars represent the minimum and maximum measured values. The post-radiation datasheet limits are 71.9mV minimum and 92.6mV maximum.

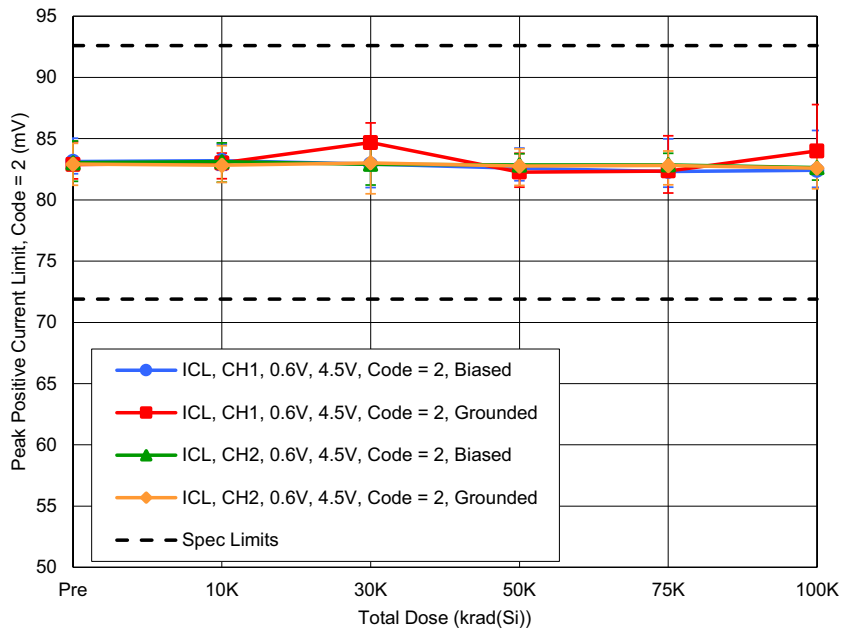

Figure 38. Average peak positive current limit with code = 2,  $V_{DD} = 4.5V$ ,  $V_{CM} = 0.6V$ , as a function of LDR irradiation. The error bars represent the minimum and maximum measured values. The post-radiation datasheet limits are 71.9mV minimum and 92.6mV maximum.

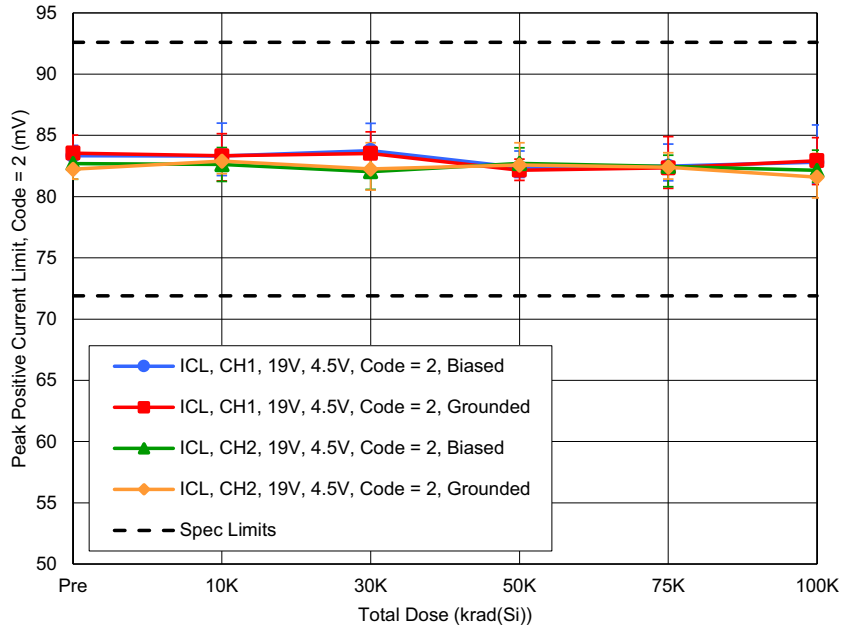

Figure 39. Average peak positive current limit with code = 2,  $V_{DD} = 4.5V$ ,  $V_{CM} = 19V$ , as a function of LDR irradiation. The error bars represent the minimum and maximum measured values. The post-radiation datasheet limits are 71.9mV minimum and 92.6mV maximum.

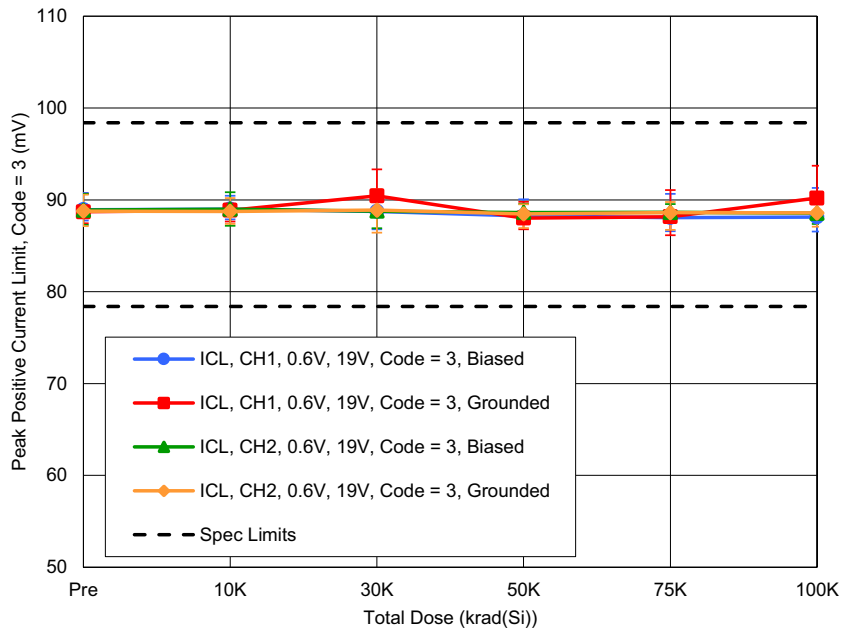

Figure 40. Average peak positive current limit with code = 3,  $V_{DD} = 19V$ ,  $V_{CM} = 0.6V$ , as a function of LDR irradiation. The error bars represent the minimum and maximum measured values. The post-radiation datasheet limits are 78.4mV minimum and 98.4mV maximum.

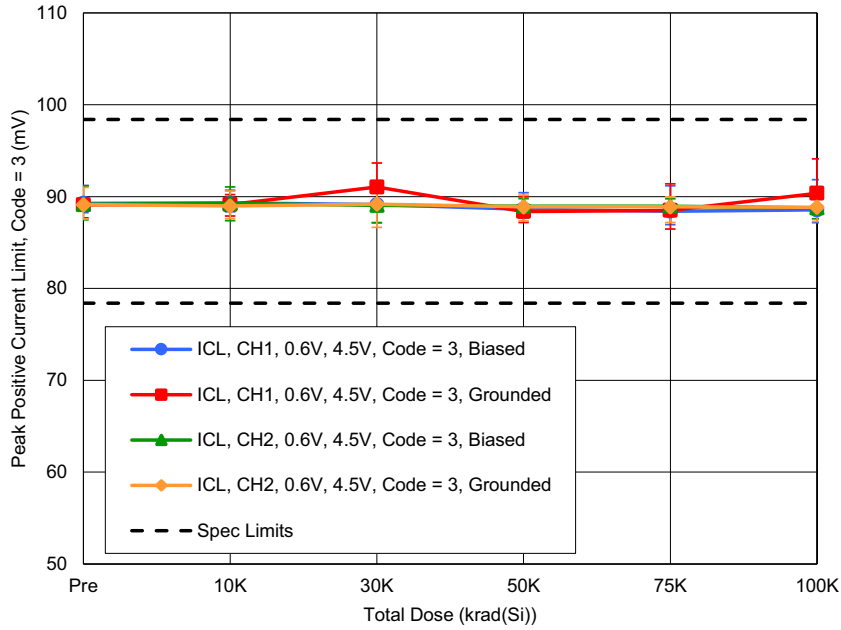

Figure 41. Average peak positive current limit with code = 3,  $V_{DD} = 4.5V$ ,  $V_{CM} = 0.6V$ , as a function of LDR irradiation. The error bars represent the minimum and maximum measured values. The post-radiation datasheet limits are 78.4mV minimum and 98.4mV maximum.

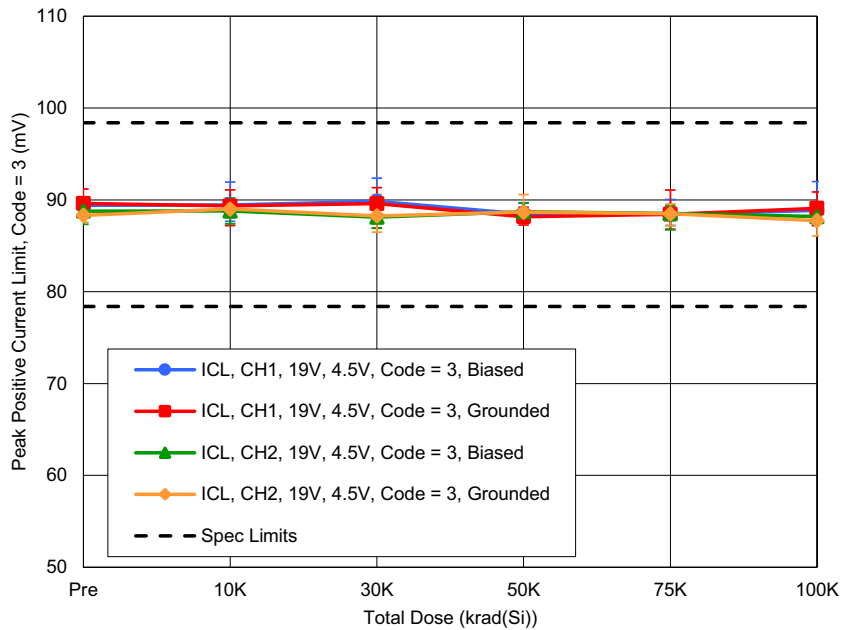

Figure 42. Average peak positive current limit with code = 3,  $V_{DD} = 4.5V$ ,  $V_{CM} = 19V$ , as a function of LDR irradiation. The error bars represent the minimum and maximum measured values. The post-radiation datasheet limits are 78.4mV minimum and 98.4mV maximum.

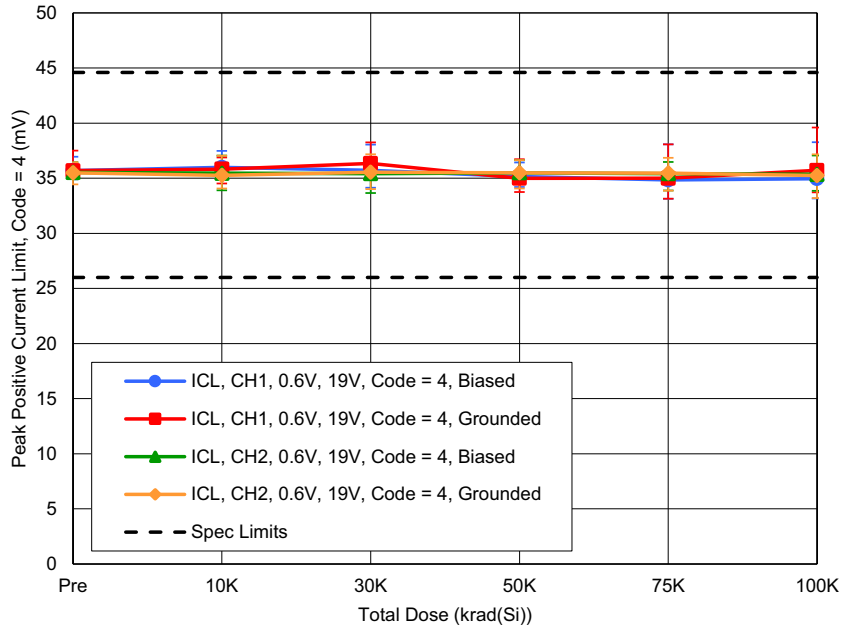

Figure 43. Average peak positive current limit with code = 4,  $V_{DD} = 19V$ ,  $V_{CM} = 0.6V$ , as a function of LDR irradiation. The error bars represent the minimum and maximum measured values. The post-radiation datasheet limits are 26mV minimum and 44.6mV maximum.

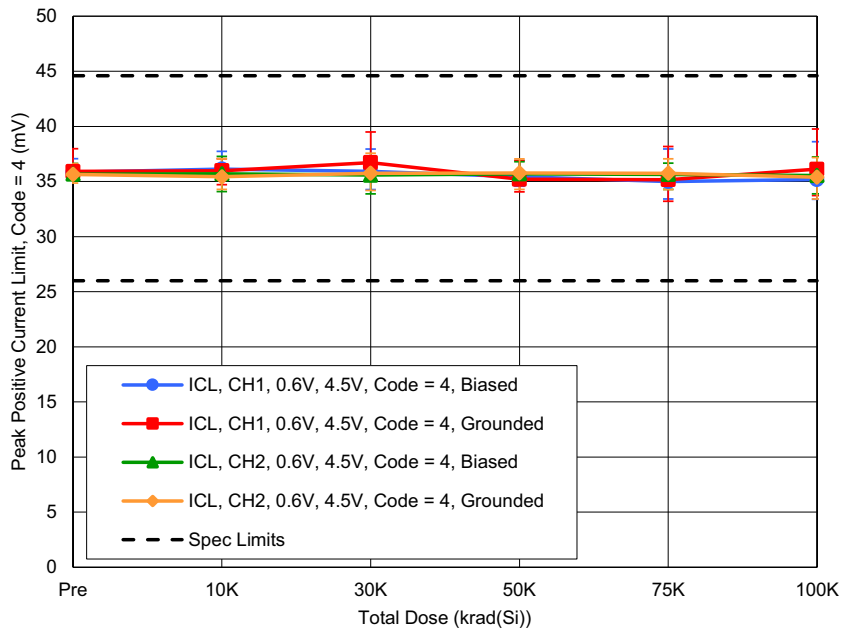

Figure 44. Average peak positive current limit with code = 4,  $V_{DD} = 4.5V$ ,  $V_{CM} = 0.6V$ , as a function of LDR irradiation. The error bars represent the minimum and maximum measured values. The post-radiation datasheet limits are 26mV minimum and 44.6mV maximum.

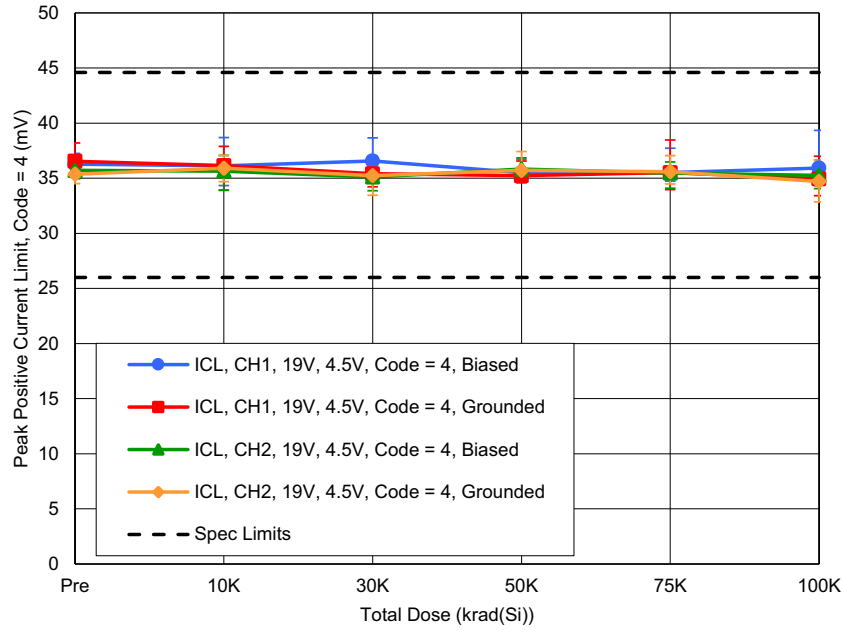

Figure 45. Average peak positive current limit with code = 4,  $V_{DD} = 4.5V$ ,  $V_{CM} = 19V$ , as a function of LDR irradiation. The error bars represent the minimum and maximum measured values. The post-radiation datasheet limits are 26mV minimum and 44.6mV maximum.

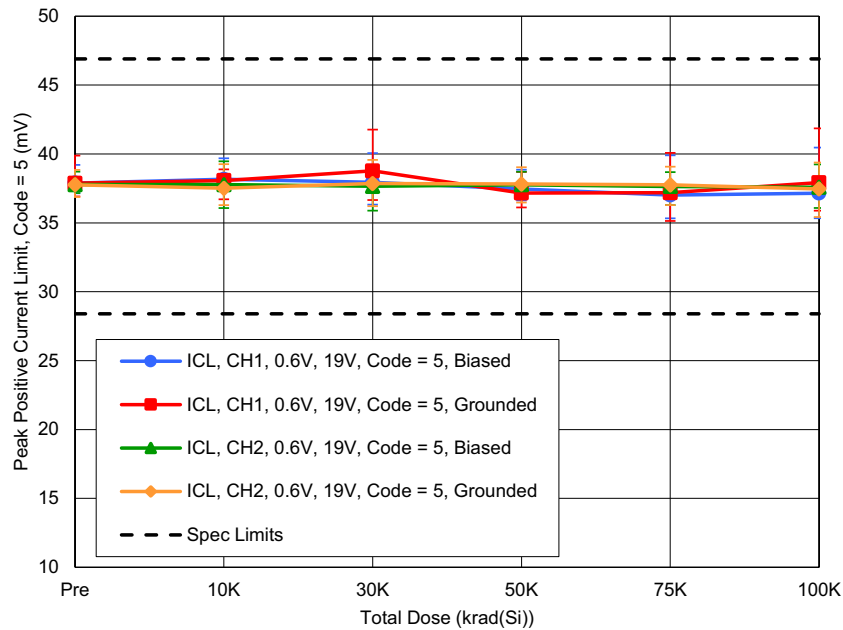

Figure 46. Average peak positive current limit with code = 5,  $V_{DD} = 19V$ ,  $V_{CM} = 0.6V$ , as a function of LDR irradiation. The error bars represent the minimum and maximum measured values. The post-radiation datasheet limits are 28.4mV minimum and 46.9mV maximum.

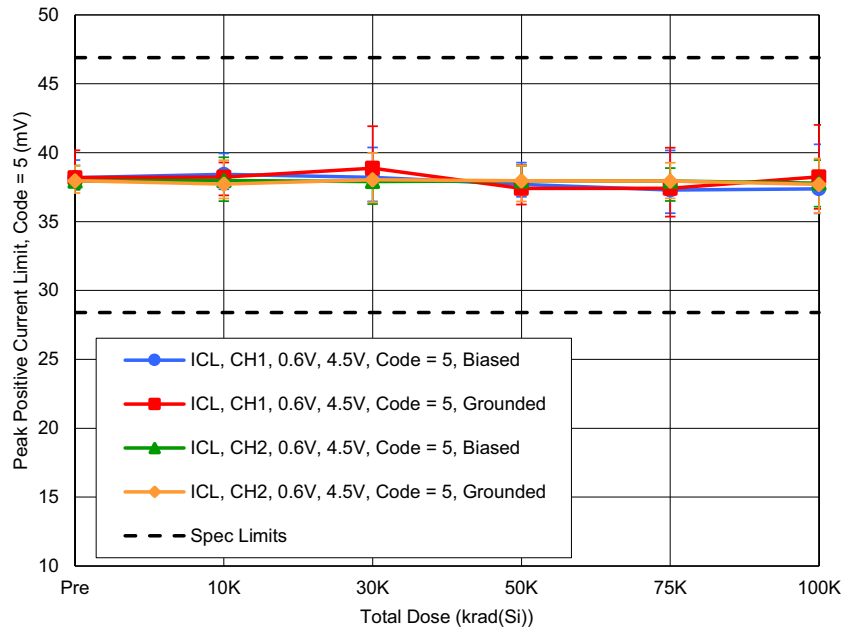

Figure 47. Average peak positive current limit with code = 5,  $V_{DD} = 4.5V$ ,  $V_{CM} = 0.6V$ , as a function of LDR irradiation. The error bars represent the minimum and maximum measured values. The post-radiation datasheet limits are 28.4mV minimum and 46.9mV maximum.

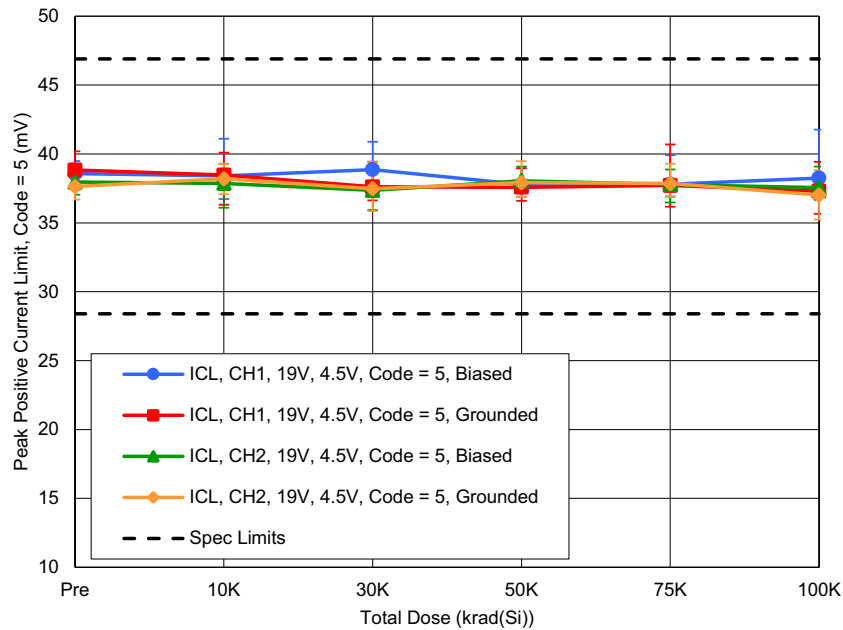

Figure 48. Average peak positive current limit with code = 5,  $V_{DD} = 4.5V$ ,  $V_{CM} = 19V$ , as a function of LDR irradiation. The error bars represent the minimum and maximum measured values. The post-radiation datasheet limits are 28.4mV minimum and 46.9mV maximum.

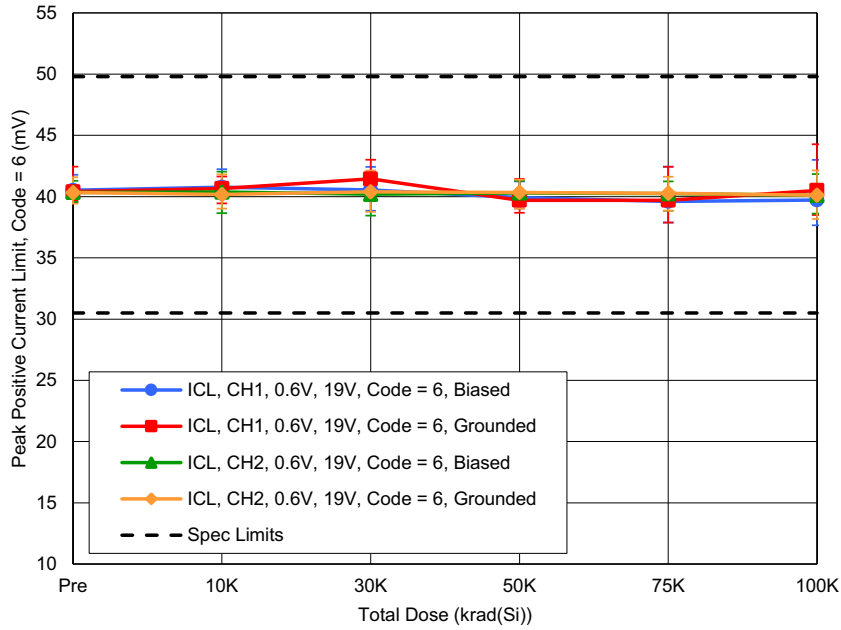

Figure 49. Average peak positive current limit with code = 6,  $V_{DD} = 19V$ ,  $V_{CM} = 0.6V$ , as a function of LDR irradiation. The error bars represent the minimum and maximum measured values. The post-radiation datasheet limits are 30.5mV minimum and 49.8mV maximum.

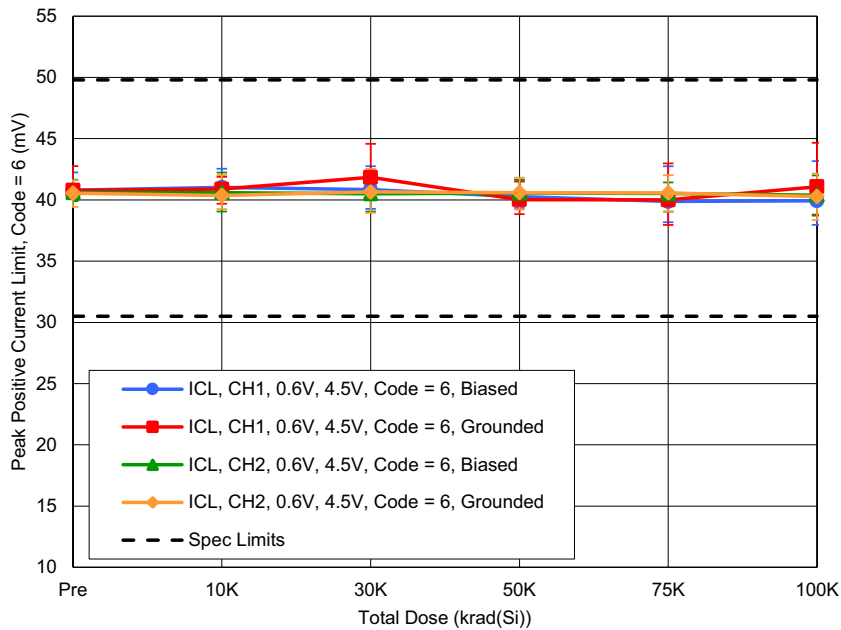

Figure 50. Average peak positive current limit with code = 6,  $V_{DD} = 4.5V$ ,  $V_{CM} = 0.6V$ , as a function of LDR irradiation. The error bars represent the minimum and maximum measured values. The post-radiation datasheet limits are 30.5mV minimum and 49.8mV maximum.

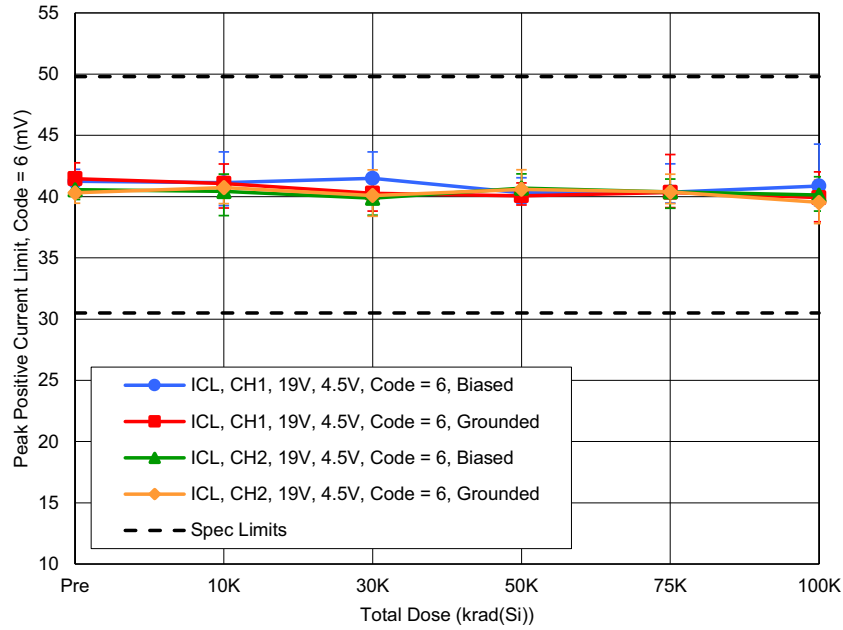

Figure 51. Average peak positive current limit with code = 6,  $V_{DD} = 4.5V$ ,  $V_{CM} = 19V$ , as a function of LDR irradiation. The error bars represent the minimum and maximum measured values. The post-radiation datasheet limits are 30.5mV minimum and 49.8mV maximum.

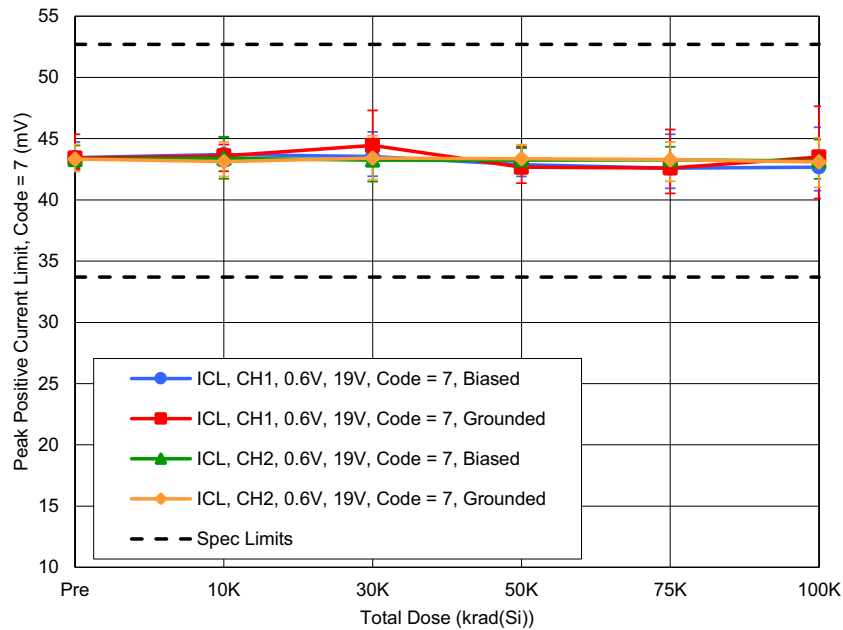

Figure 52. Average peak positive current limit with code = 7,  $V_{DD} = 19V$ ,  $V_{CM} = 0.6V$ , as a function of LDR irradiation. The error bars represent the minimum and maximum measured values. The post-radiation datasheet limits are 33.7mV minimum and 52.7mV maximum.

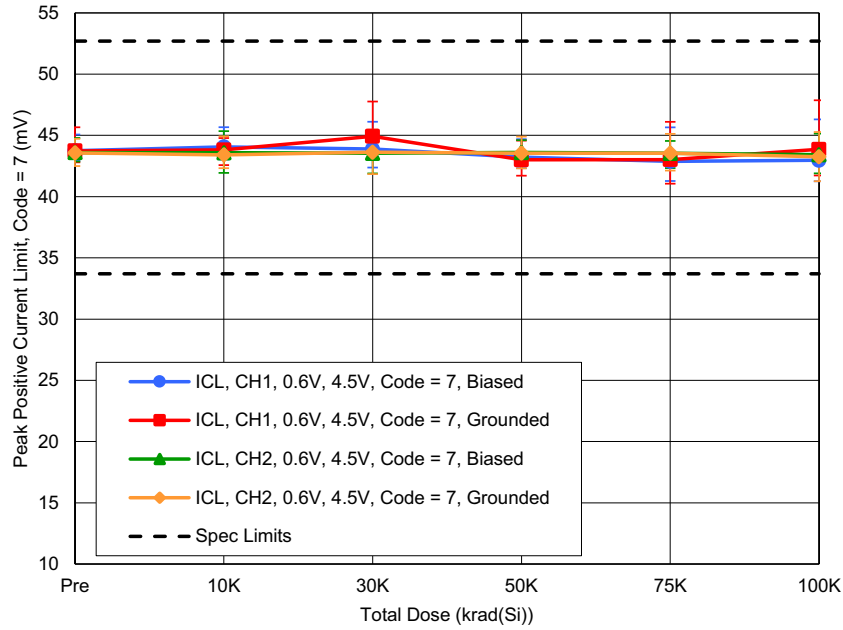

Figure 53. Average peak positive current limit with code = 7,  $V_{DD} = 4.5V$ ,  $V_{CM} = 0.6V$ , as a function of LDR irradiation. The error bars represent the minimum and maximum measured values. The post-radiation datasheet limits are 33.7mV minimum and 52.7mV maximum.

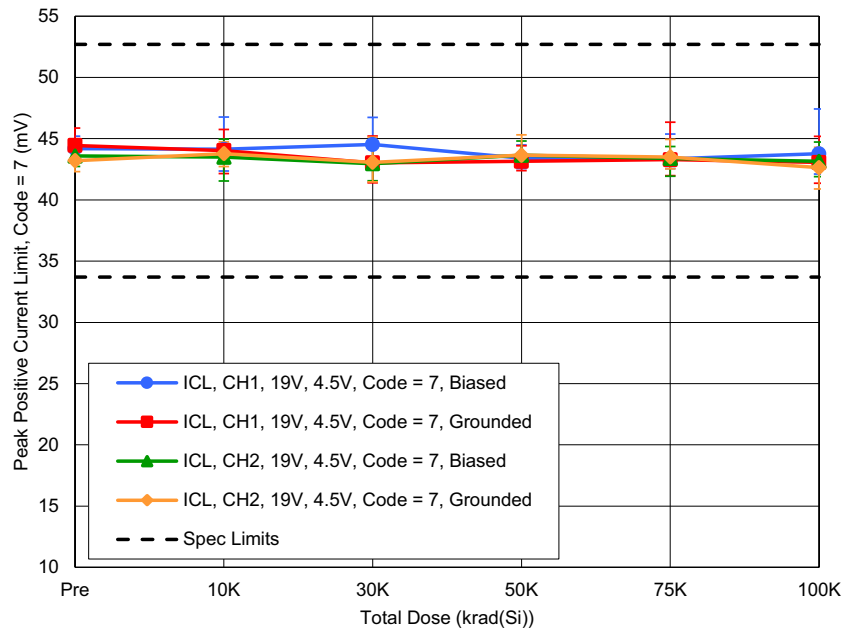

Figure 54. Average peak positive current limit with code = 7,  $V_{DD} = 4.5V$ ,  $V_{CM} = 19V$ , as a function of LDR irradiation. The error bars represent the minimum and maximum measured values. The post-radiation datasheet limits are 33.7mV minimum and 52.7mV maximum.

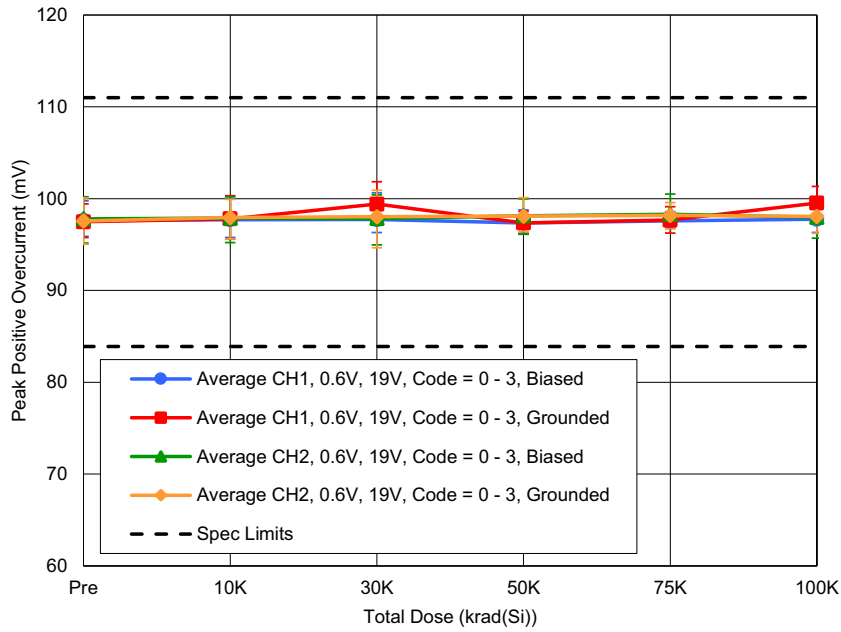

Figure 55. Average peak positive overcurrent with code = 0 - 3, V<sub>DD</sub> = 19V, V<sub>CM</sub> = 0.6V, as a function of LDR irradiation. The error bars represent the minimum and maximum measured values. The post-radiation datasheet limits are 83.9mV minimum and 111mV maximum.

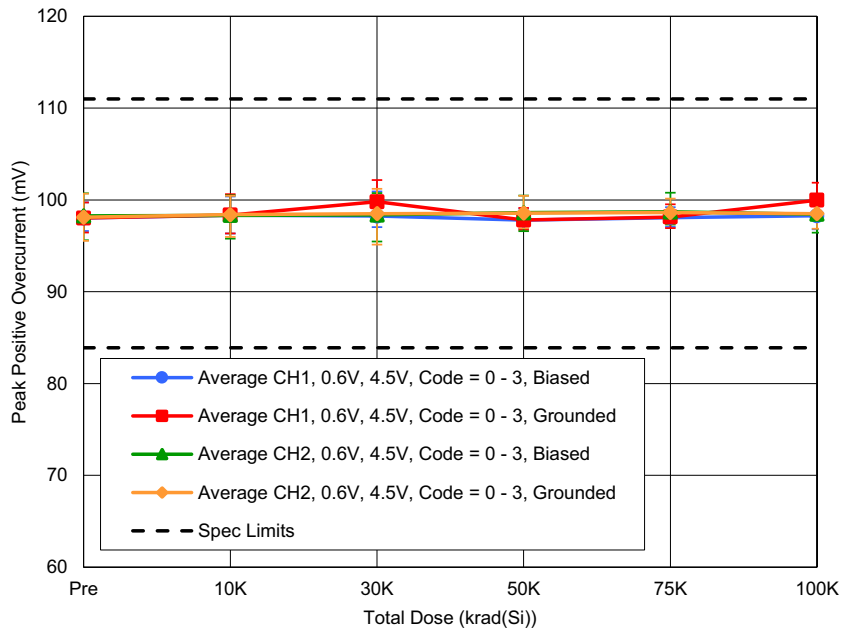

Figure 56. Average peak positive overcurrent with code = 0 - 3, V<sub>DD</sub> = 4.5V, V<sub>CM</sub> = 0.6V, as a function of LDR irradiation. The error bars represent the minimum and maximum measured values. The post-radiation datasheet limits are 83.9mV minimum and 111mV maximum.

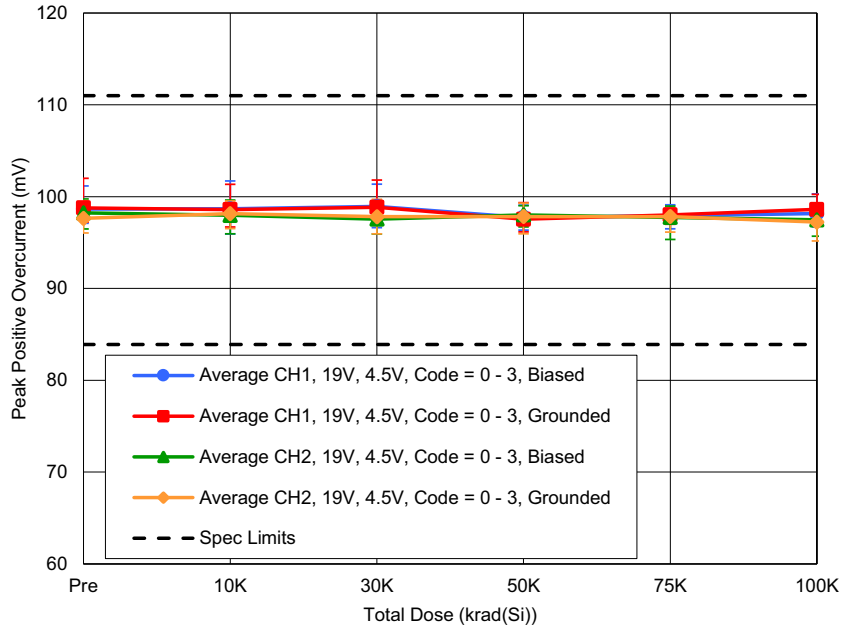

Figure 57. Average peak positive overcurrent with code = 0 - 3,  $V_{DD} = 4.5V$ ,  $V_{CM} = 19V$ , as a function of LDR irradiation. The error bars represent the minimum and maximum measured values. The post-radiation datasheet limits are 83.9mV minimum and 111mV maximum.

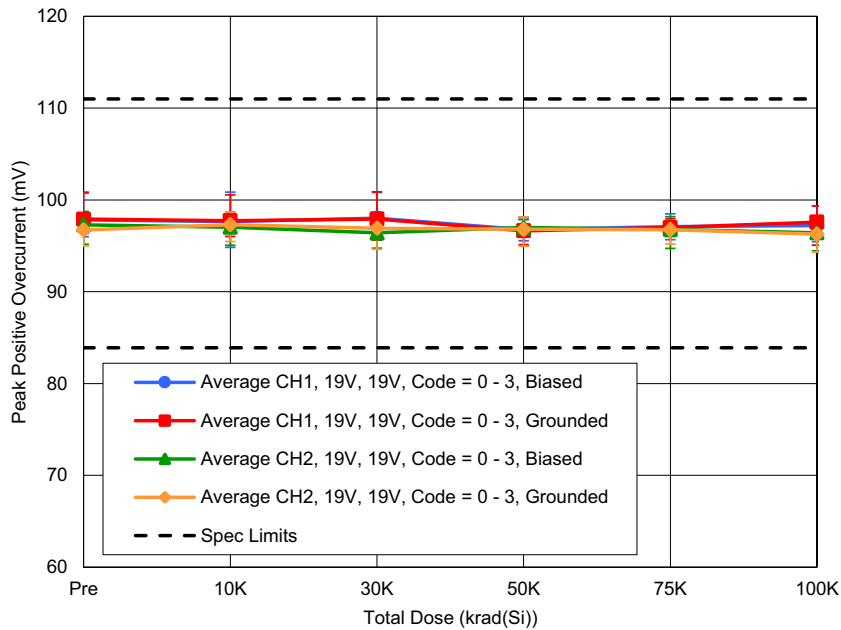

Figure 58. Average peak positive overcurrent with code = 0 - 3,  $V_{DD} = 19V$ ,  $V_{CM} = 19V$ , as a function of LDR irradiation. The error bars represent the minimum and maximum measured values. The post-radiation datasheet limits are 83.9mV minimum and 111mV maximum.

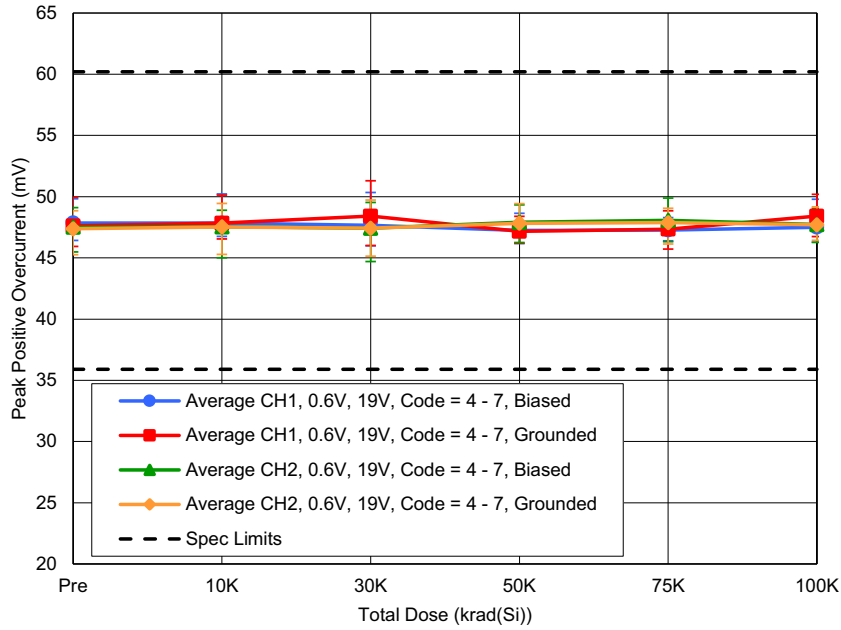

Figure 59. Average peak positive overcurrent with code = 4 - 7,  $V_{DD} = 19V$ ,  $V_{CM} = 0.6V$ , as a function of LDR irradiation. The error bars represent the minimum and maximum measured values. The post-radiation datasheet limits are 35.9mV minimum and 60.2mV maximum.

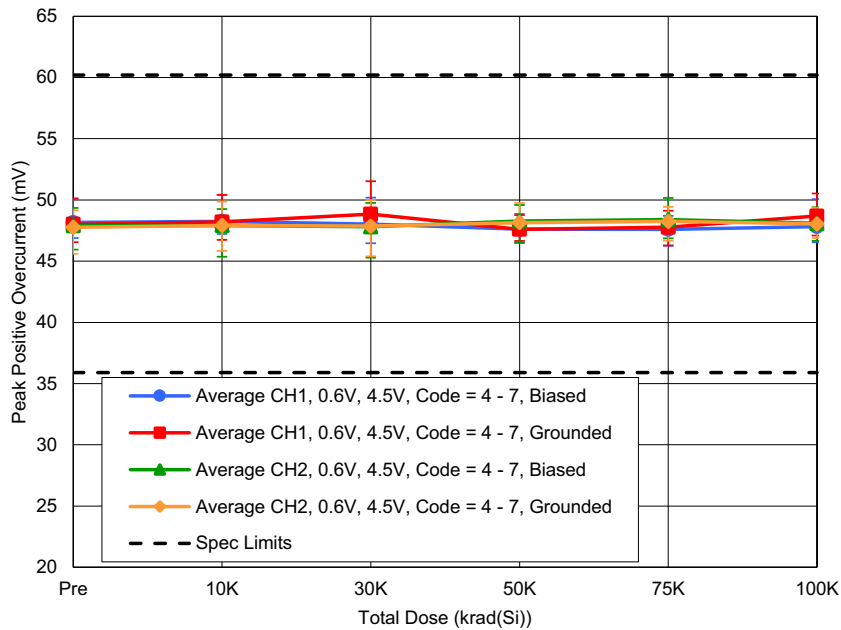

Figure 60. Average peak positive overcurrent with code = 4 - 7,  $V_{DD} = 4.5V$ ,  $V_{CM} = 0.6V$ , as a function of LDR irradiation. The error bars represent the minimum and maximum measured values. The post-radiation datasheet limits are 35.9mV minimum and 60.2mV maximum.

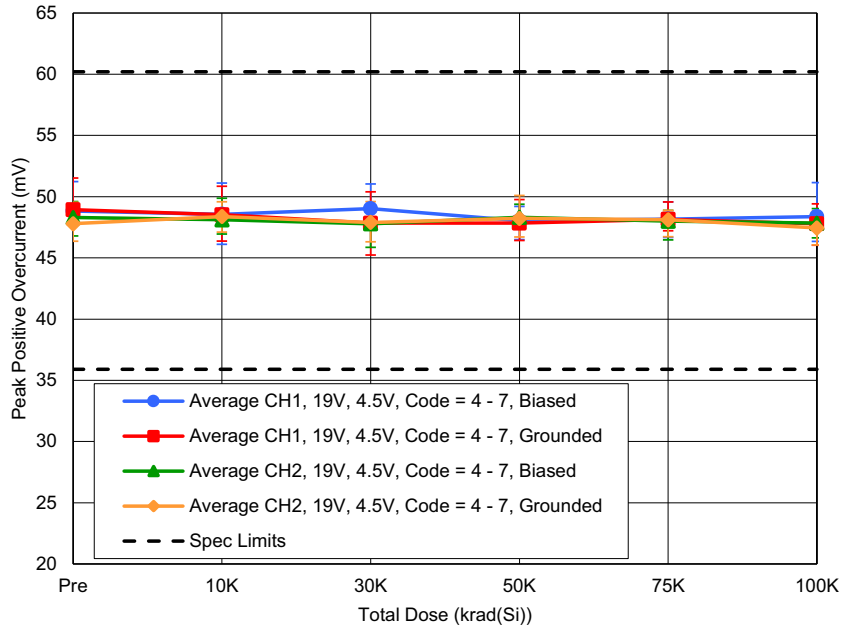

Figure 61. Average peak positive overcurrent with code = 4 - 7,  $V_{DD} = 4.5V$ ,  $V_{CM} = 19V$ , as a function of LDR irradiation. The error bars represent the minimum and maximum measured values. The post-radiation datasheet limits are 35.9mV minimum and 60.2mV maximum.

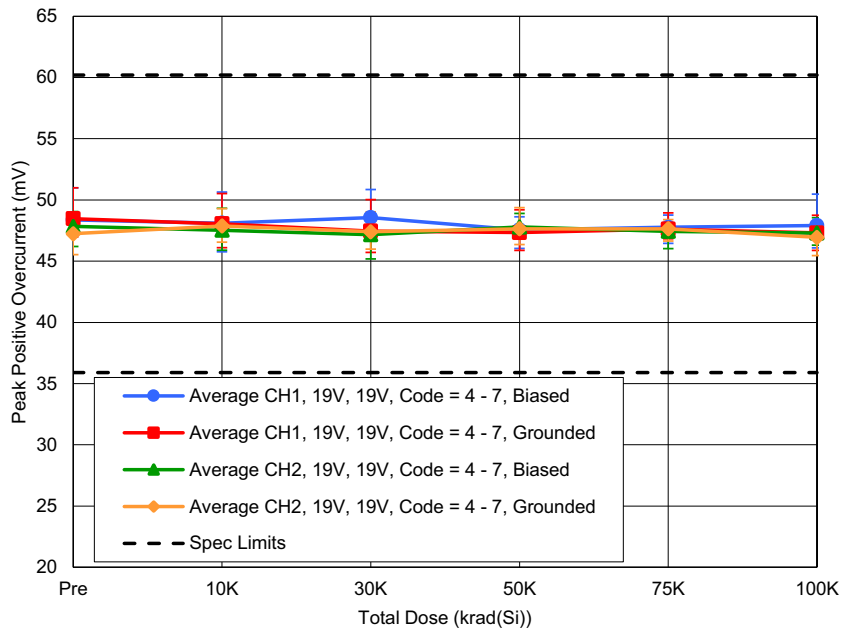

Figure 62. Average peak positive overcurrent with code = 4 - 7,  $V_{DD} = 19V$ ,  $V_{CM} = 19V$ , as a function of LDR irradiation. The error bars represent the minimum and maximum measured values. The post-radiation datasheet limits are 35.9mV minimum and 60.2mV maximum.

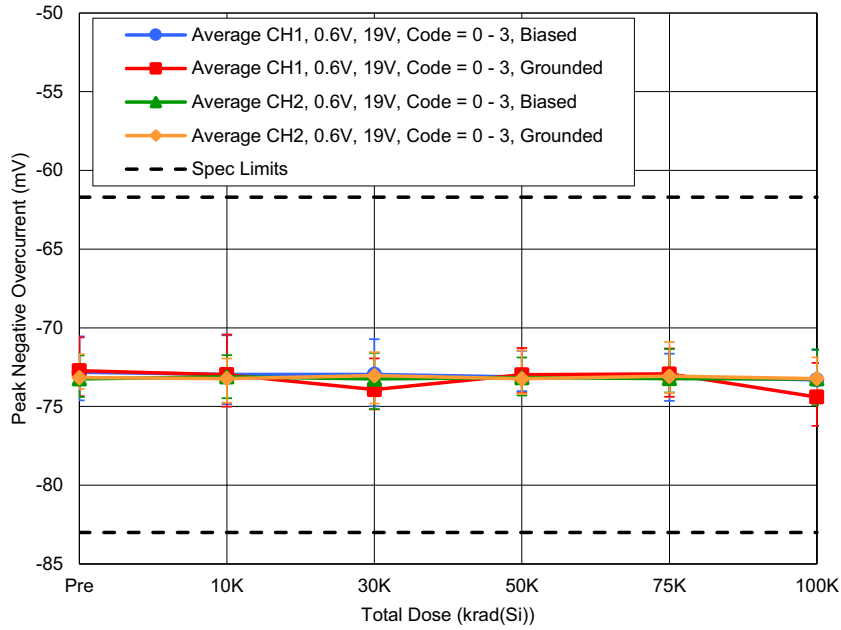

Figure 63. Average peak negative overcurrent with code = 0 - 3,  $V_{DD} = 19V$ ,  $V_{CM} = 0.6V$ , as a function of LDR irradiation. The error bars represent the minimum and maximum measured values. The post-radiation datasheet limits are -83mV minimum and -61.7mV maximum.

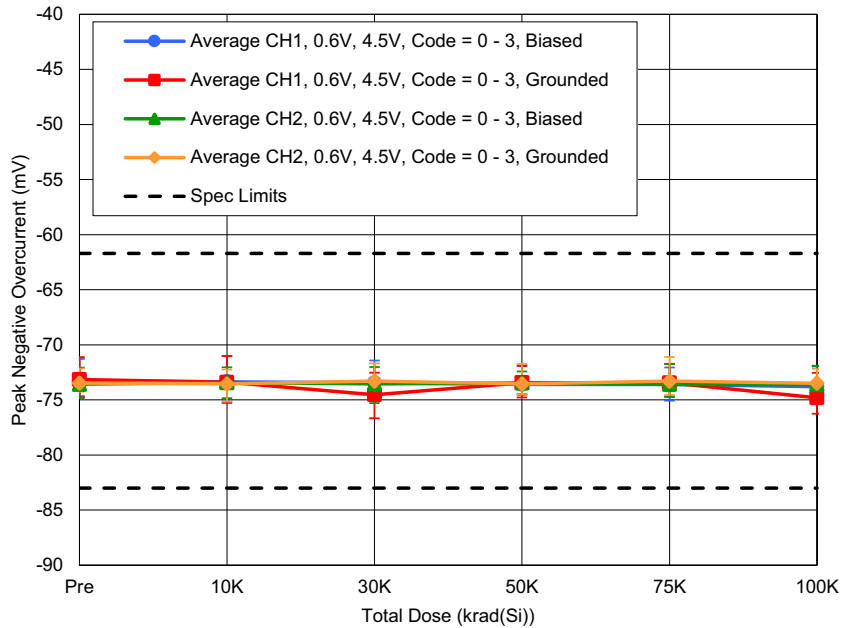

Figure 64. Average peak negative overcurrent with code = 0 - 3,  $V_{DD} = 4.5V$ ,  $V_{CM} = 0.6V$ , as a function of LDR irradiation. The error bars represent the minimum and maximum measured values. The post-radiation datasheet limits are -83mV minimum and -61.7mV maximum.

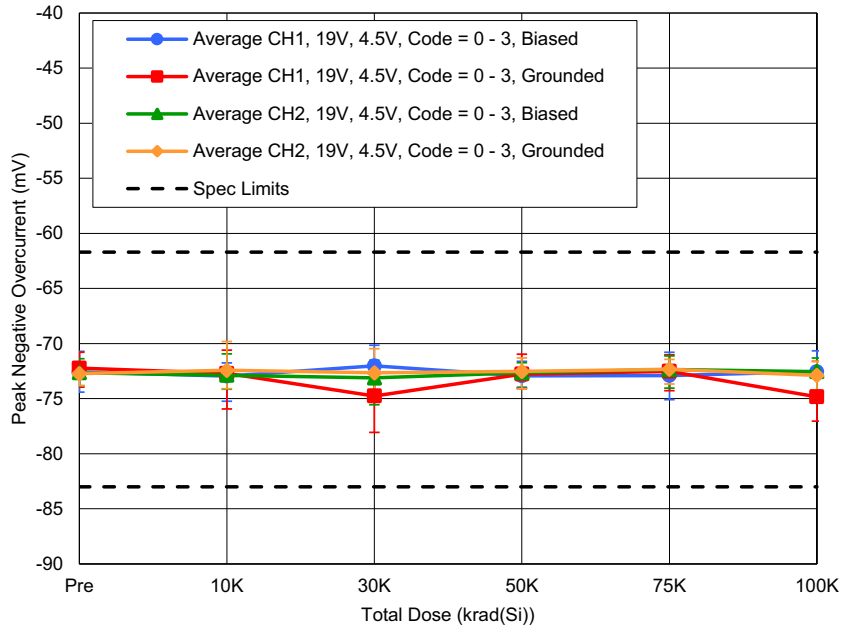

Figure 65. Average peak negative overcurrent with code = 0 - 3,  $V_{DD} = 4.5V$ ,  $V_{CM} = 19V$ , as a function of LDR irradiation. The error bars represent the minimum and maximum measured values. The post-radiation datasheet limits are -83mV minimum and -61.7mV maximum.

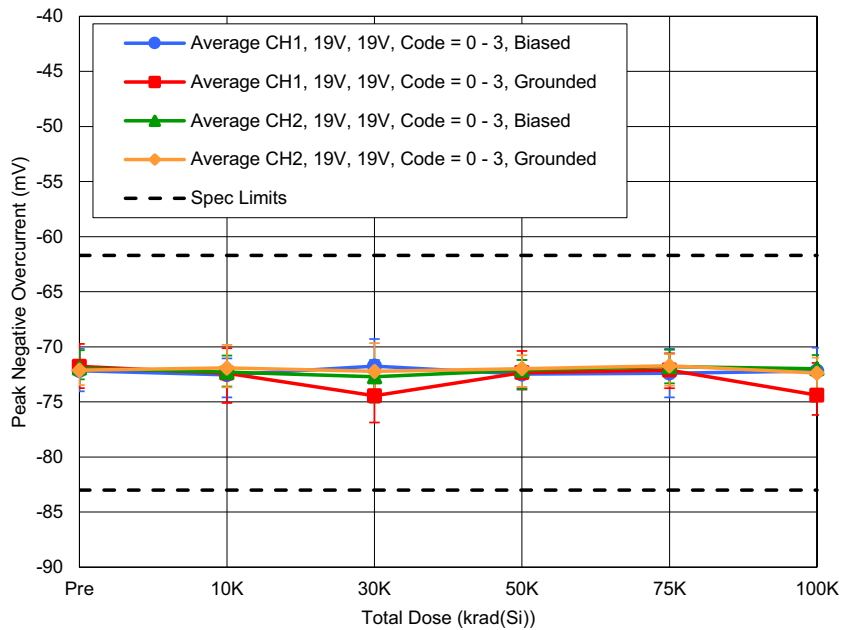

Figure 66. Average peak negative overcurrent with code = 0 - 3,  $V_{DD} = 19V$ ,  $V_{CM} = 19V$ , as a function of LDR irradiation. The error bars represent the minimum and maximum measured values. The post-radiation datasheet limits are -83mV minimum and -61.7mV maximum.

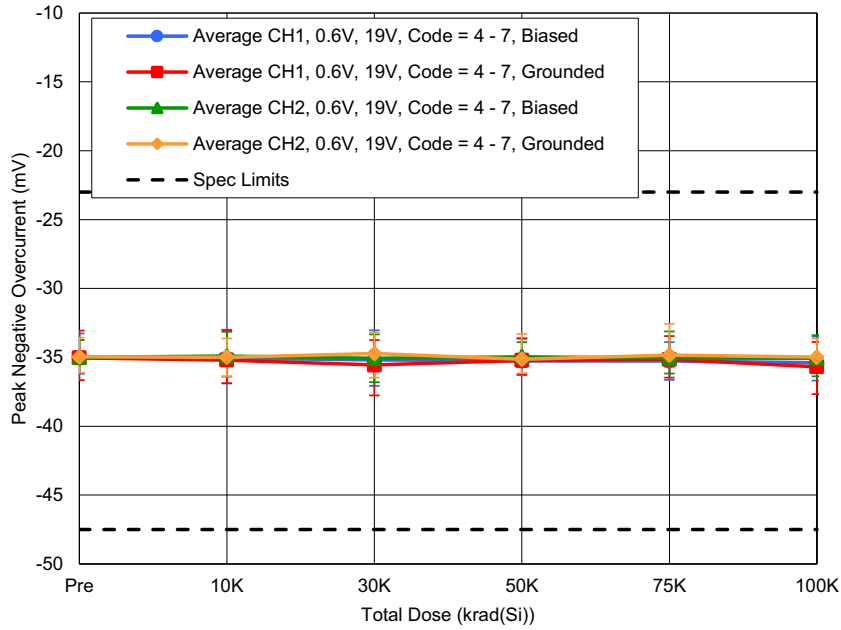

Figure 67. Average peak negative overcurrent with code = 4 - 7,  $V_{DD} = 19V$ ,  $V_{CM} = 0.6V$ , as a function of LDR irradiation. The error bars represent the minimum and maximum measured values. The post-radiation datasheet limits are -47.5mV minimum and -23mV maximum.

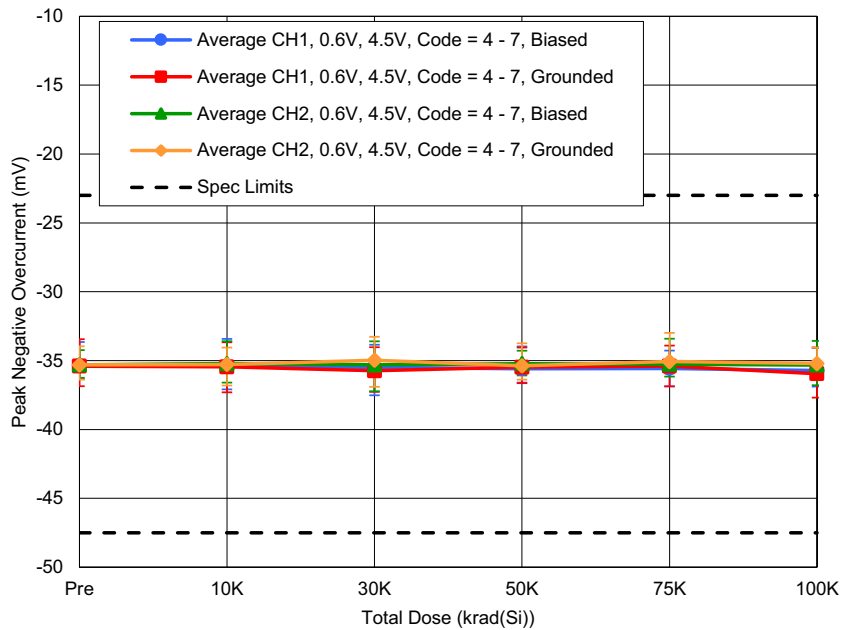

Figure 68. Average peak negative overcurrent with code = 4 - 7,  $V_{DD} = 4.5V$ ,  $V_{CM} = 0.6V$ , as a function of LDR irradiation. The error bars represent the minimum and maximum measured values. The post-radiation datasheet limits are -47.5mV minimum and -23mV maximum.

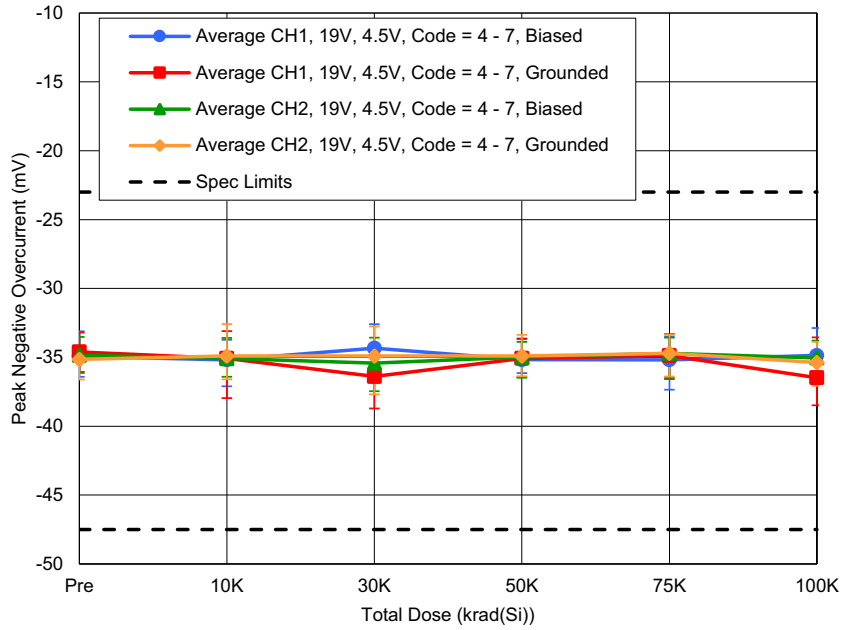

Figure 69. Average peak negative overcurrent with code = 4 - 7,  $V_{DD} = 4.5V$ ,  $V_{CM} = 19V$ , as a function of LDR irradiation. The error bars represent the minimum and maximum measured values. The post-radiation datasheet limits are -47.5mV minimum and -23mV maximum.

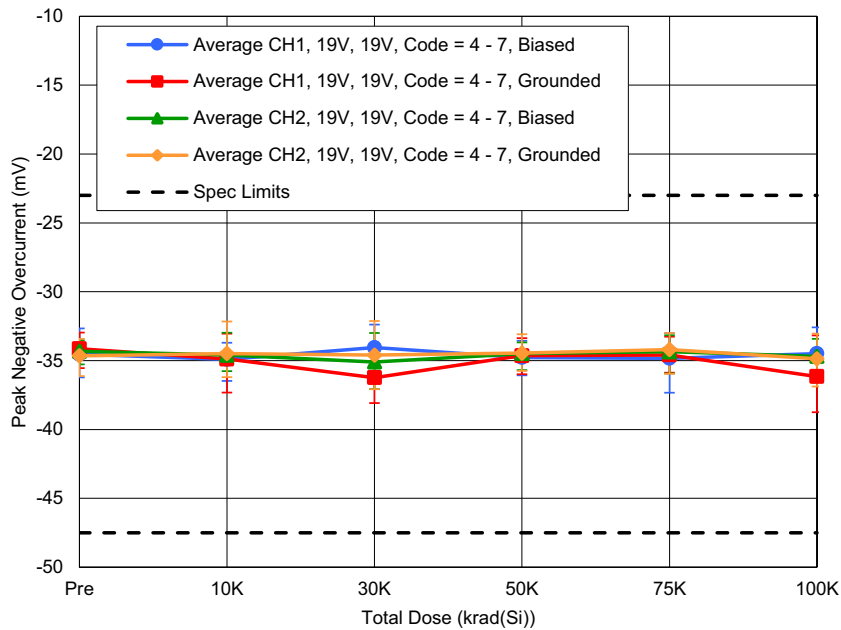

Figure 70. Average peak negative overcurrent with code = 4 - 7,  $V_{DD} = 19V$ ,  $V_{CM} = 19V$ , as a function of LDR irradiation. The error bars represent the minimum and maximum measured values. The post-radiation datasheet limits are -47.5mV minimum and -23mV maximum.

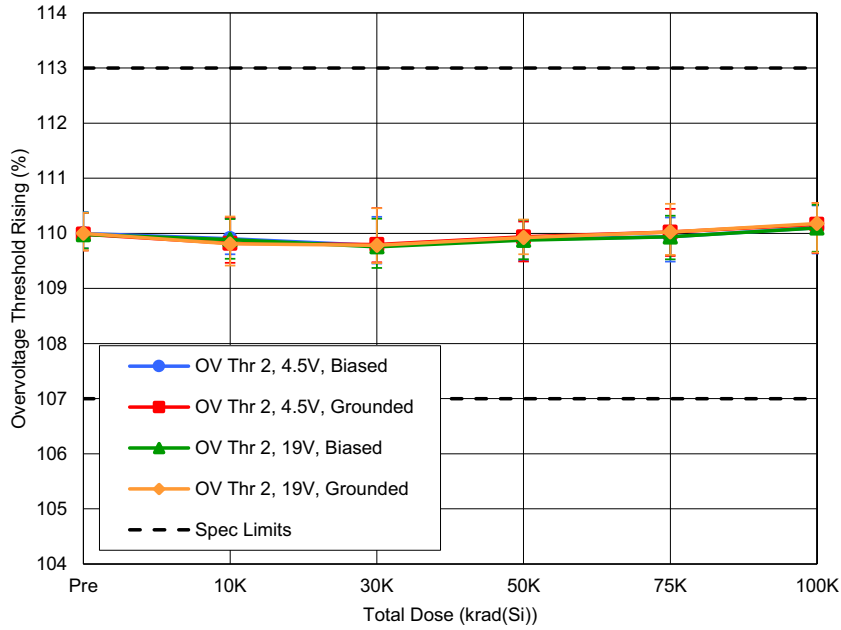

Figure 71. Average overvoltage threshold rising,  $V_{DD} = 4.5V$  and  $19V$ , as a function of LDR irradiation. The error bars represent the minimum and maximum measured values. The post-radiation datasheet limits are 107% minimum and 113% maximum.

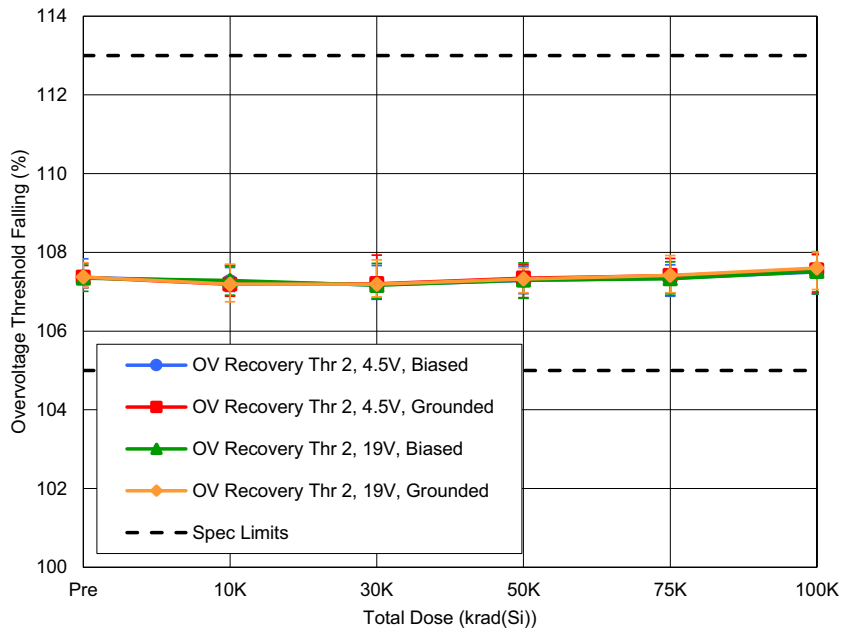

Figure 72. Average overvoltage threshold falling (recovery),  $V_{DD} = 4.5V$  and  $19V$ , as a function of LDR irradiation. The error bars represent the minimum and maximum measured values. The post-radiation datasheet limits are 105% minimum and 113% maximum.

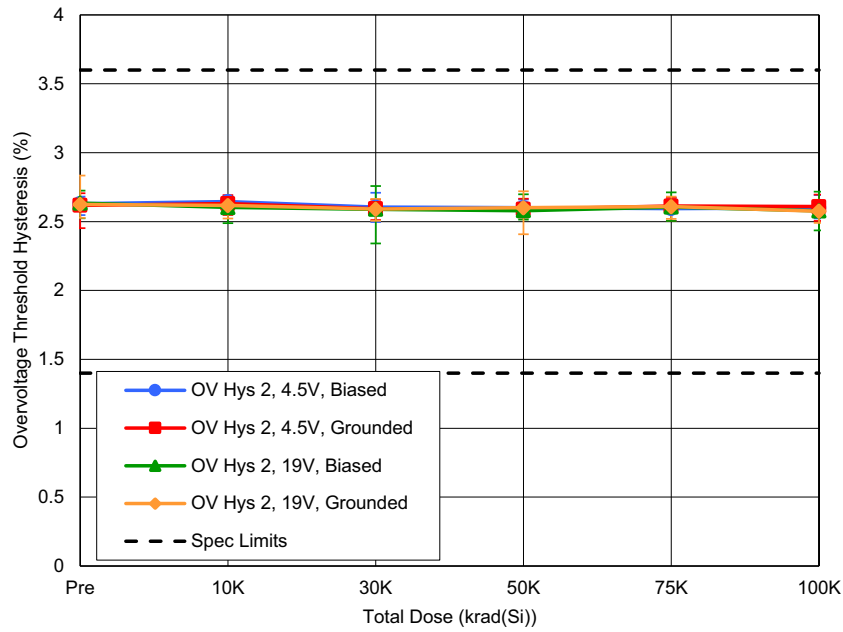

Figure 73. Average overvoltage threshold hysteresis,  $V_{DD} = 4.5V$  and  $19V$ , as a function of LDR irradiation. The error bars represent the minimum and maximum measured values. The post-radiation datasheet limits are 1.4% minimum and 3.5% maximum.

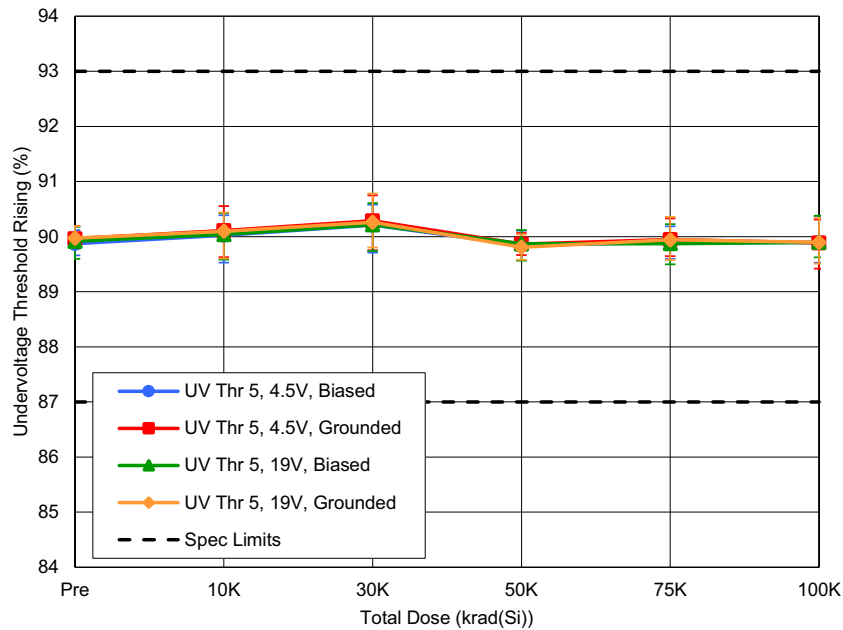

Figure 74. Average undervoltage threshold rising,  $V_{DD} = 4.5V$  and  $19V$ , as a function of LDR irradiation. The error bars represent the minimum and maximum measured values. The post-radiation datasheet limits are 87% minimum and 93% maximum.

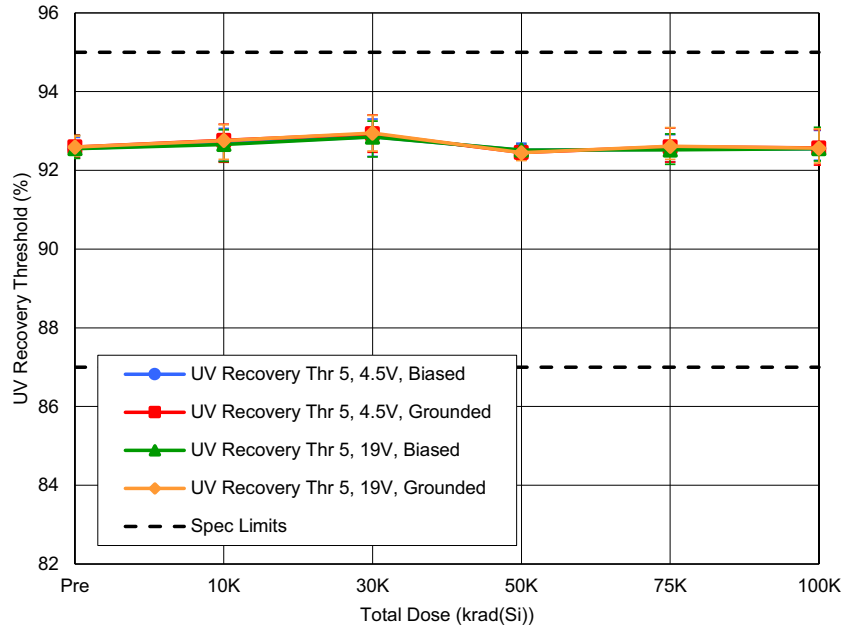

Figure 75. Average undervoltage threshold falling (recovery),  $V_{DD} = 4.5V$  and  $19V$ , as a function of LDR irradiation. The error bars represent the minimum and maximum measured values. The post-radiation datasheet limits are 87% minimum and 95% maximum.

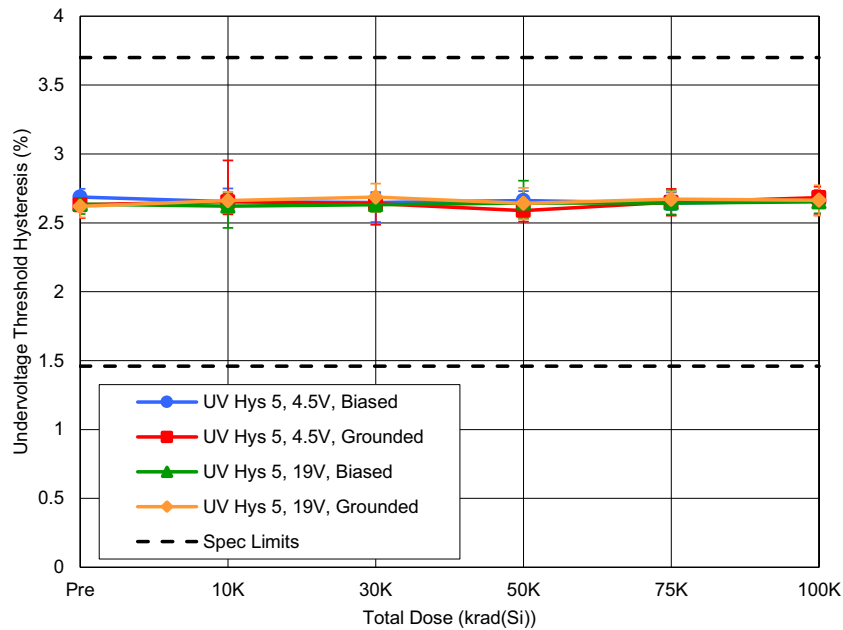

Figure 76. Average undervoltage threshold falling hysteresis,  $V_{DD} = 4.5V$  and  $19V$ , as a function of LDR irradiation. The error bars represent the minimum and maximum measured values. The post-radiation datasheet limits are 1.46% minimum and 3.7% maximum.

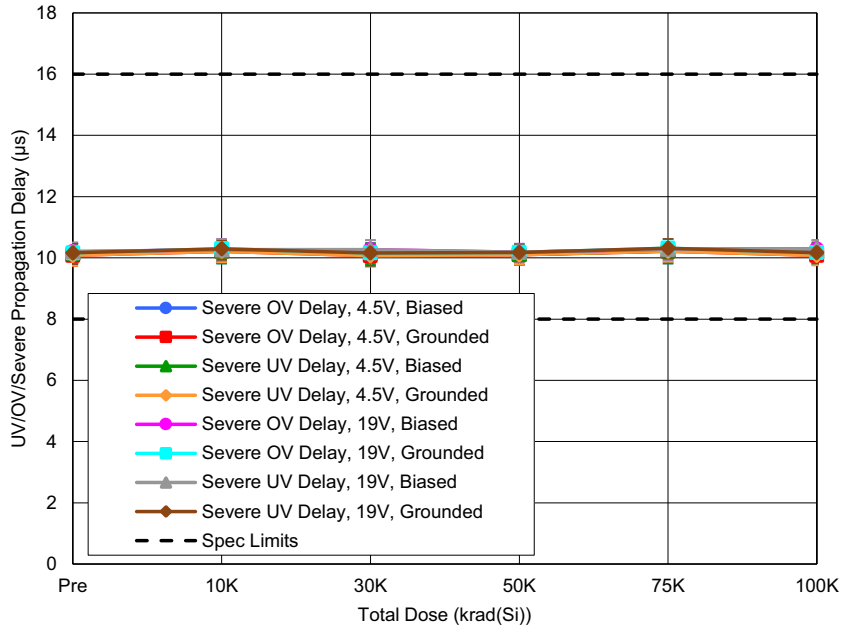

Figure 77. Average UV, OV Severe Propagation Delay,  $V_{DD} = 4.5V$  and  $19V$ , as a function of LDR irradiation. The error bars represent the minimum and maximum measured values. The post-radiation datasheet limits are  $8\mu s$  minimum and  $16\mu s$  maximum.

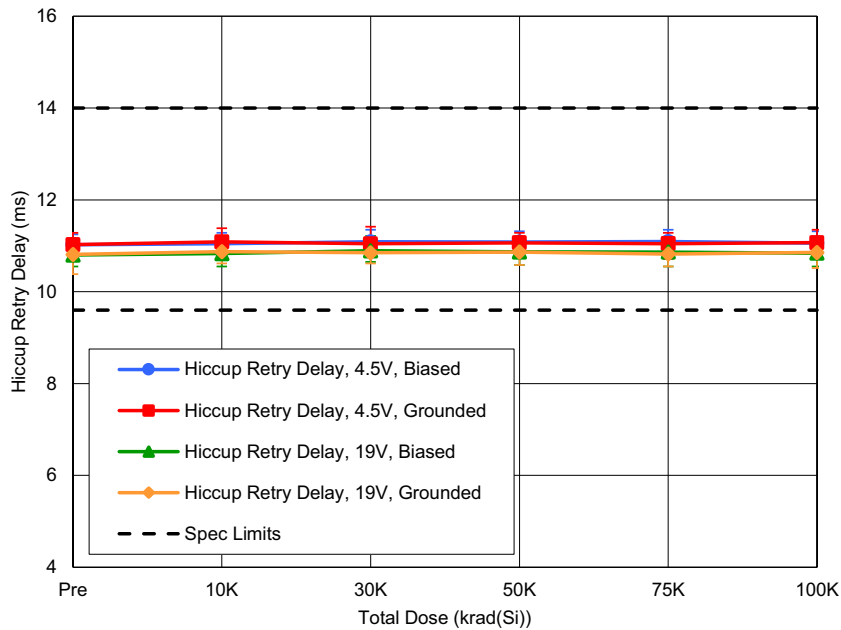

Figure 78. Average Hiccup Retry Delay,  $V_{DD} = 4.5V$  and  $19V$ , as a function of LDR irradiation. The error bars represent the minimum and maximum measured values. The post-radiation datasheet limits are  $9.6ms$  minimum and  $14ms$  maximum.

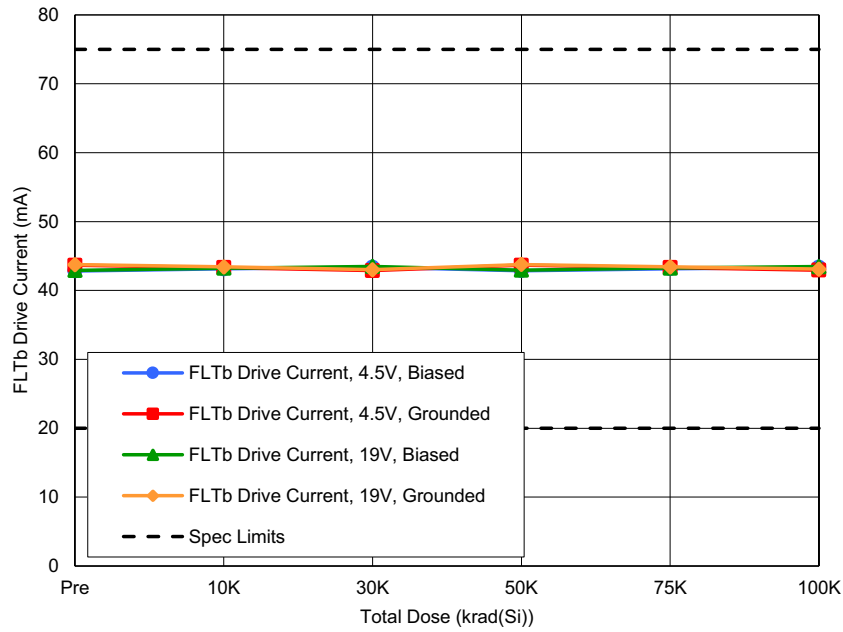

Figure 79. Average FLTb Drive Current,  $V_{DD} = 4.5V$  and  $19V$ , as a function of LDR irradiation. The error bars represent the minimum and maximum measured values. The post-radiation datasheet limits are 20mA minimum and 75mA maximum.

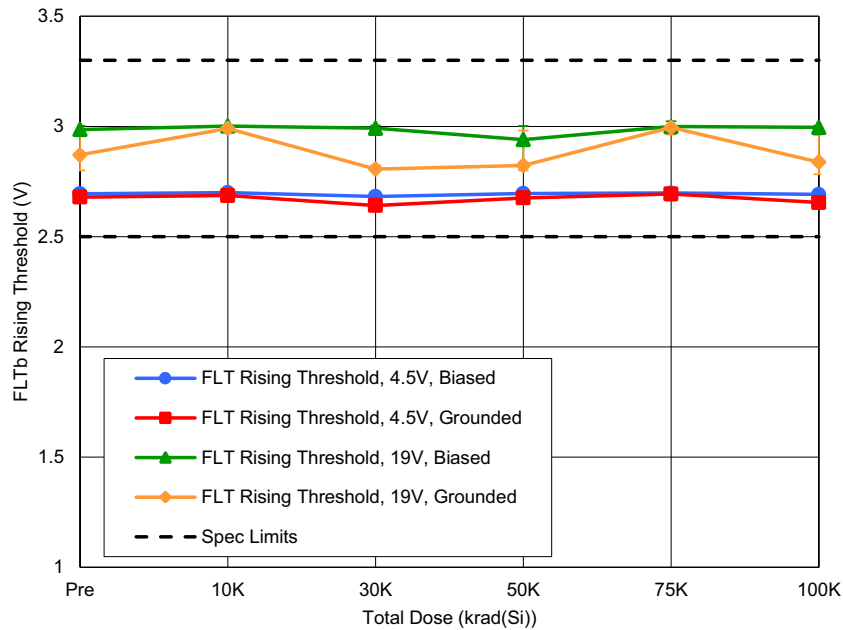

Figure 80. Average FLTb rising threshold,  $V_{DD} = 4.5V$  and  $19V$ , as a function of LDR irradiation. The error bars represent the minimum and maximum measured values. The post-radiation datasheet limits are 2.5V minimum and 3.3V maximum.

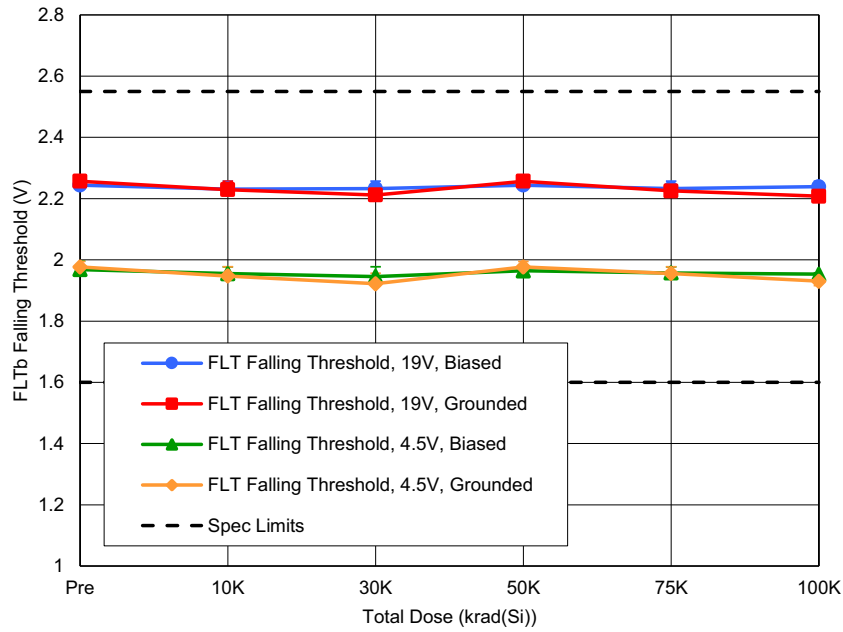

Figure 81. Average FLTb falling threshold,  $V_{DD} = 4.5V$  and  $19V$ , as a function of LDR irradiation. The error bars represent the minimum and maximum measured values. The post-radiation datasheet limits are  $1.6V$  minimum and  $2.55V$  maximum.

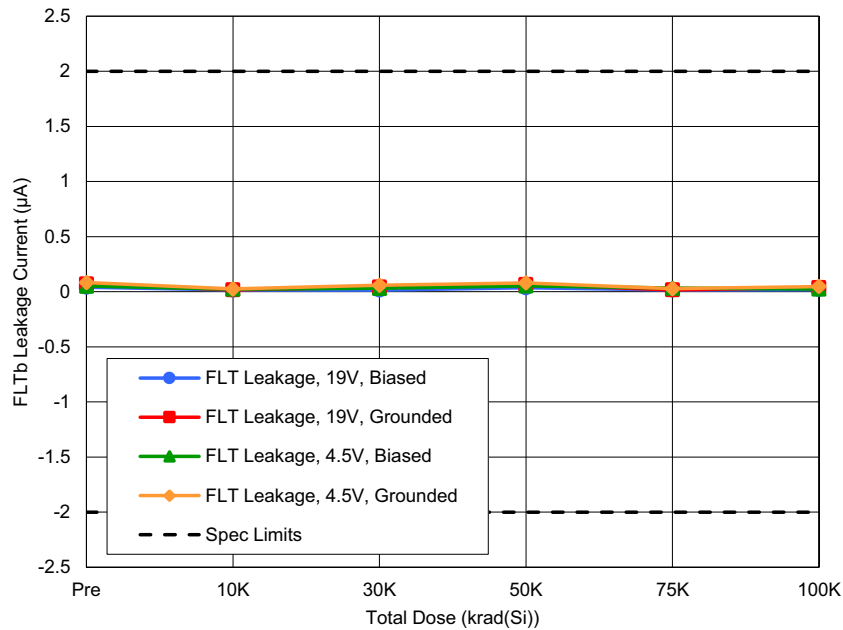

Figure 82. Average FLTb leakage current,  $V_{DD} = 4.5V$  and  $19V$ , as a function of LDR irradiation. The error bars represent the minimum and maximum measured values. The post-radiation datasheet limits are  $-2\mu A$  minimum and  $2\mu A$  maximum.

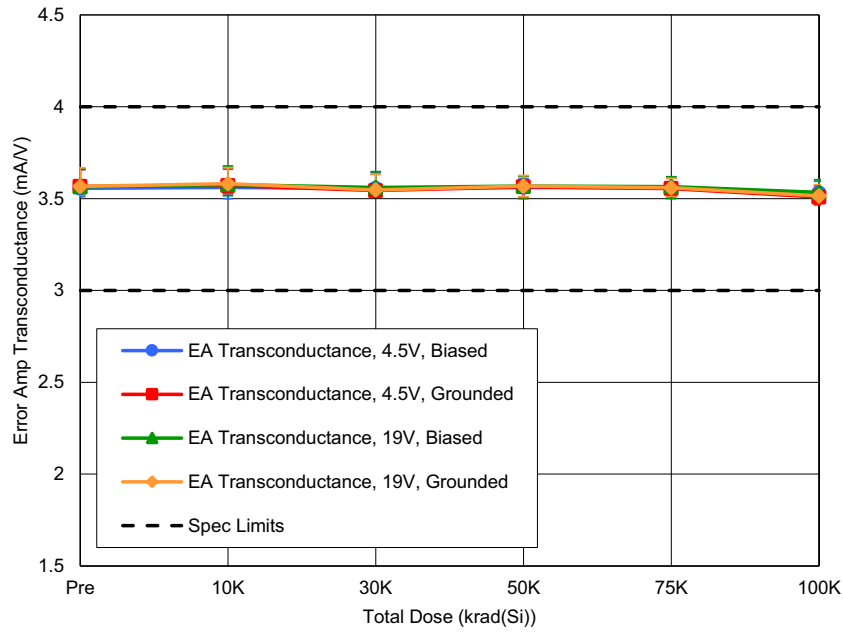

Figure 83. Average Error Amp transconductance,  $V_{DD} = 4.5V$  and  $19V$ , as a function of LDR irradiation. The error bars represent the minimum and maximum measured values. The post-radiation datasheet limits are  $3mA/V$  minimum and  $4mA/V$  maximum.

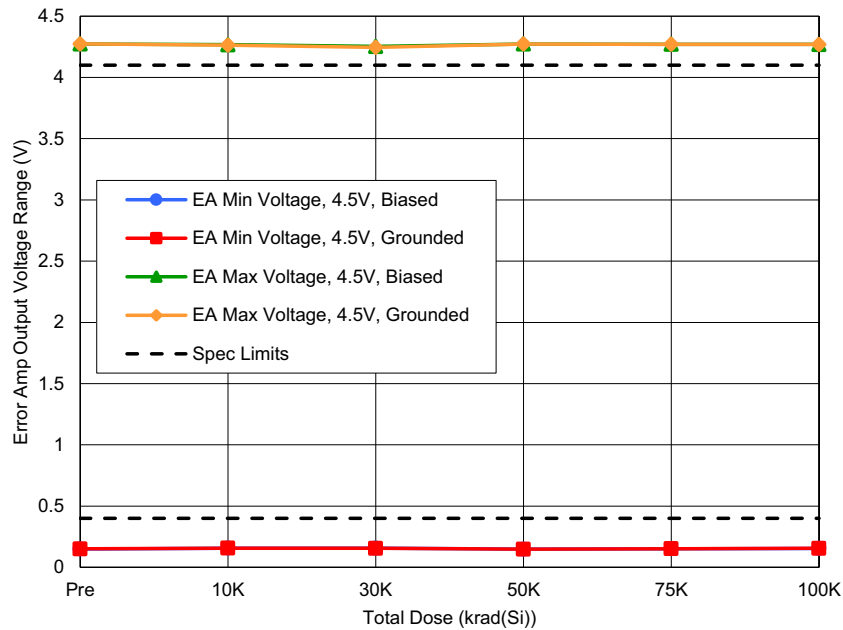

Figure 84. Average Error Amp output voltage range,  $V_{DD} = 4.5V$ , as a function of LDR irradiation. The error bars represent the minimum and maximum measured values. The post-radiation datasheet limits are  $0.4V$  minimum (maximum low) and  $4.1V$  maximum (minimum high).

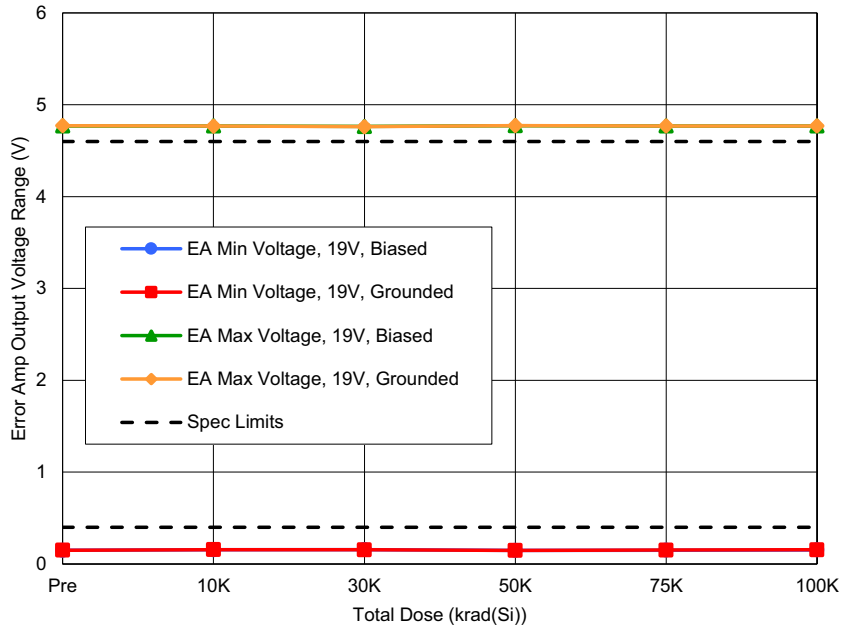

Figure 85. Average Error Amp output voltage range,  $V_{DD} = 19V$ , as a function of LDR irradiation. The error bars represent the minimum and maximum measured values. The post-radiation datasheet limits are 0.4V minimum (maximum low) and 4.6V maximum (minimum high).

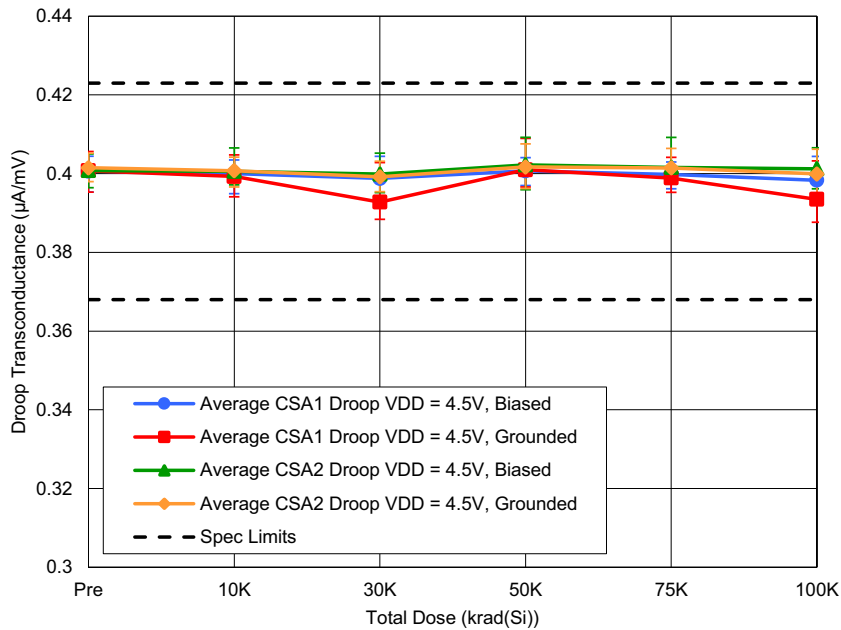

Figure 86. Average current sense amplifier droop transconductance,  $V_{DD} = 4.5V$ ,  $DROOP = 600mV$ , as a function of LDR irradiation. The error bars represent the minimum and maximum measured values. The post-radiation datasheet limits are 0.368V minimum and 0.423V maximum.

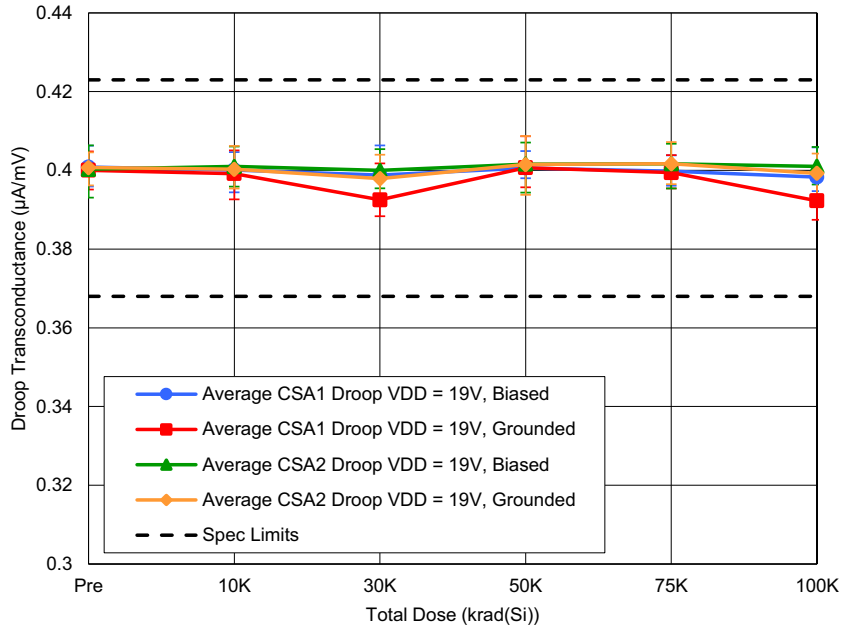

Figure 87. Average current sense amplifier droop transconductance,  $V_{DD} = 19V$ ,  $DROOP = 600mV$ , as a function of LDR irradiation. The error bars represent the minimum and maximum measured values. The post-radiation datasheet limits are 0.368V minimum and 0.423V maximum.

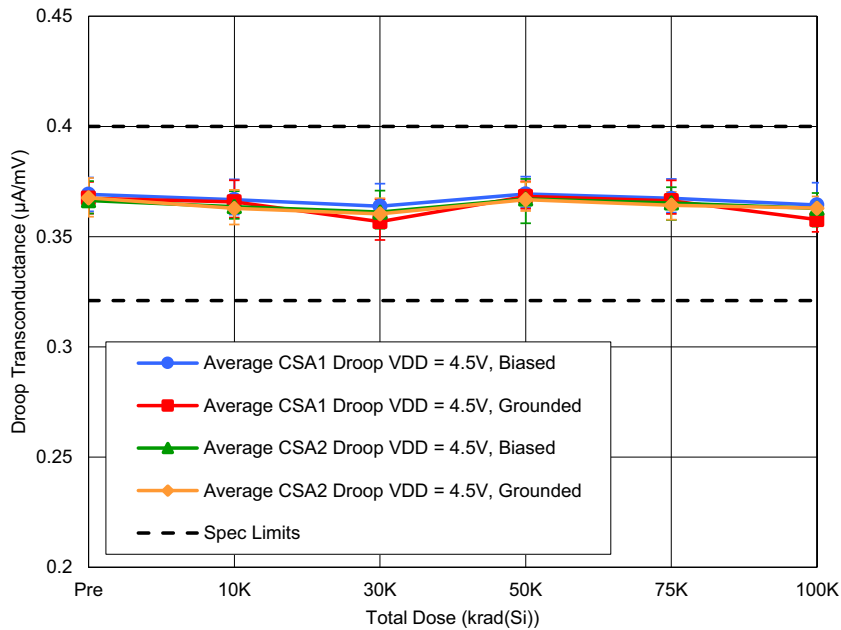

Figure 88. Average current sense amplifier droop transconductance,  $V_{DD} = 4.5V$ ,  $DROOP = 200mV$ , as a function of LDR irradiation. The error bars represent the minimum and maximum measured values. The post-radiation datasheet limits are 0.321V minimum and 0.400V maximum.

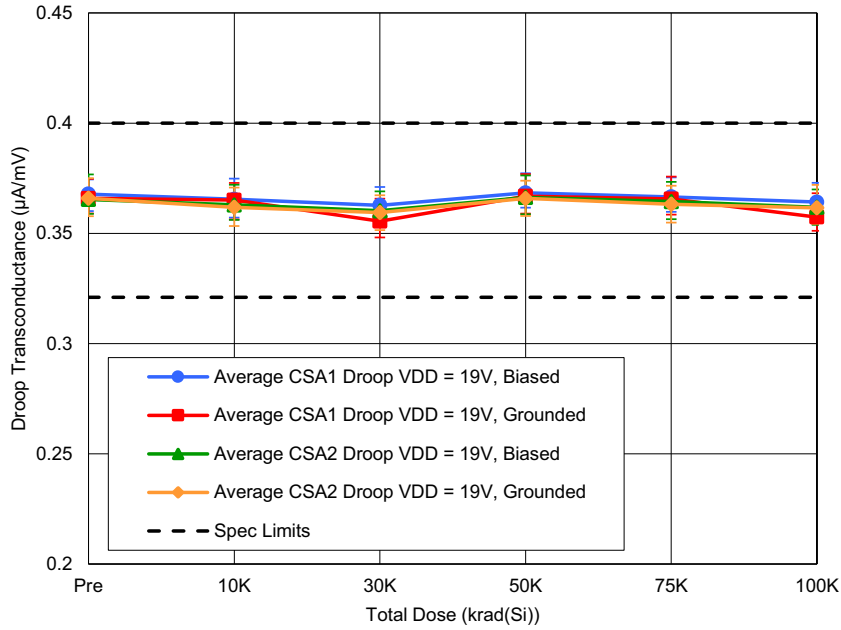

Figure 89. Average current sense amplifier droop transconductance, V<sub>DD</sub> = 19V, DROOP = 200mV, as a function of LDR irradiation. The error bars represent the minimum and maximum measured values. The post-radiation datasheet limits are 0.321V minimum and 0.400V maximum.

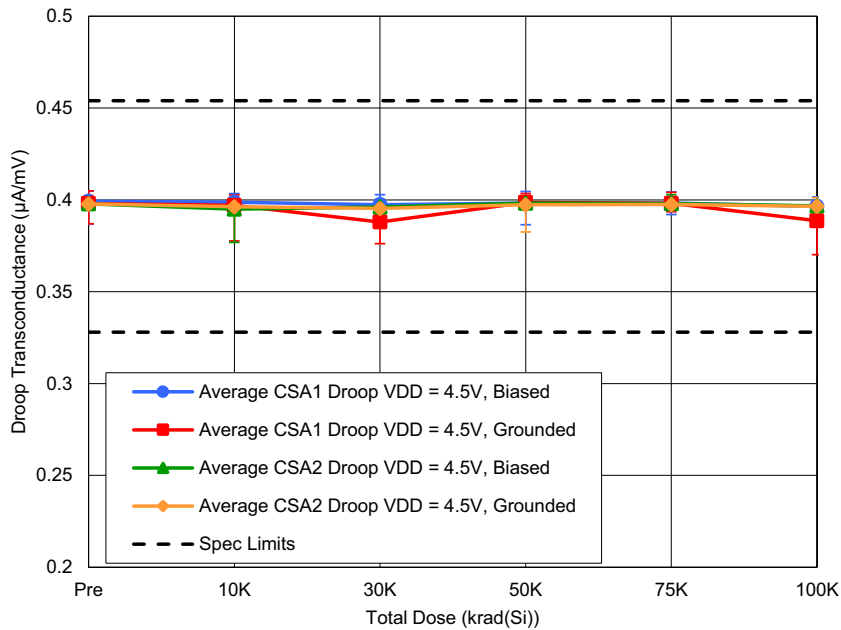

Figure 90. Average current sense amplifier droop transconductance, V<sub>DD</sub> = 4.5V, DROOP = 500mV, as a function of LDR irradiation. The error bars represent the minimum and maximum measured values. The post-radiation datasheet limits are 0.328V minimum and 0.454V maximum.

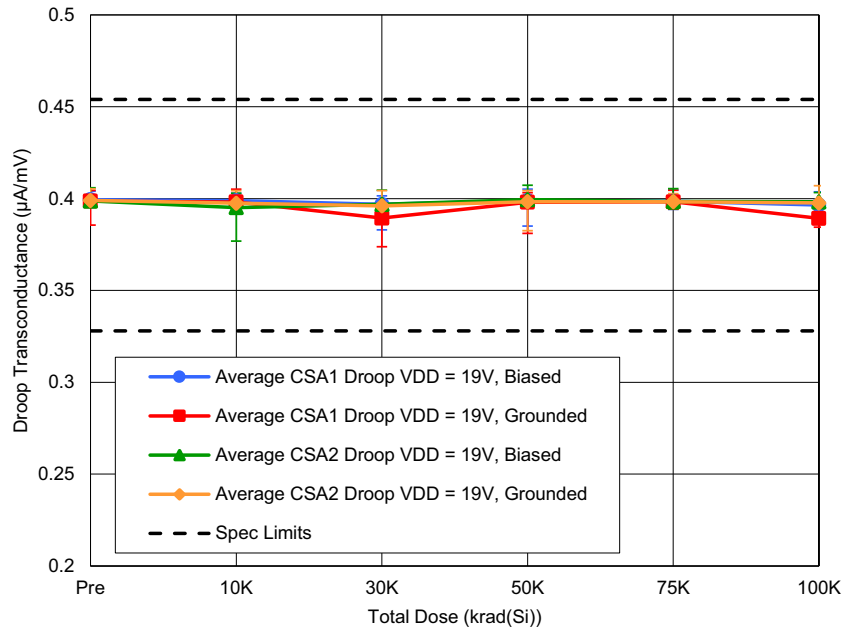

Figure 91. Average current sense amplifier droop transconductance,  $V_{DD} = 19V$ ,  $DROOP = 500mV$ , as a function of LDR irradiation. The error bars represent the minimum and maximum measured values. The post-radiation datasheet limits are 0.328V minimum and 0.454V maximum.

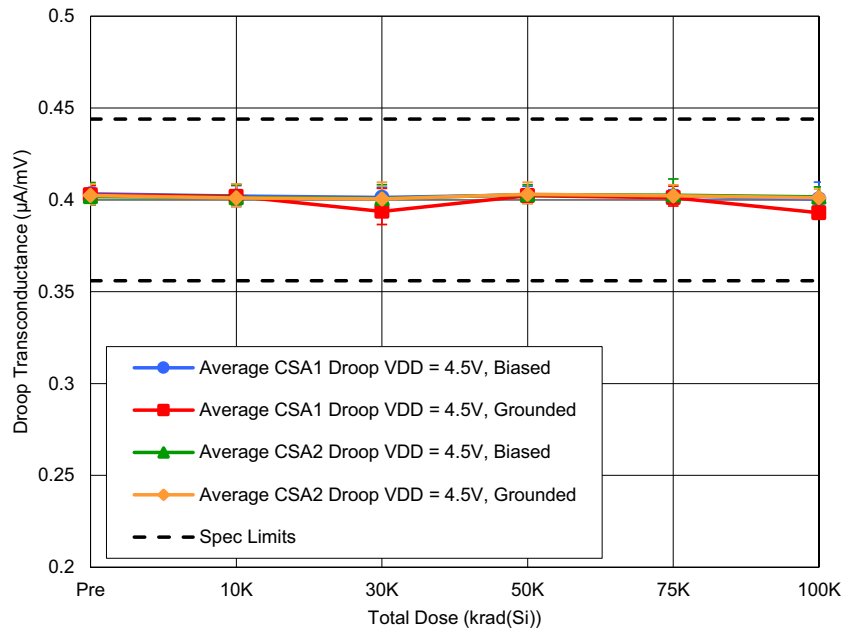

Figure 92. Average current sense amplifier droop transconductance,  $V_{DD} = 4.5V$ ,  $DROOP = 1.2V$ , as a function of LDR irradiation. The error bars represent the minimum and maximum measured values. The post-radiation datasheet limits are 0.356V minimum and 0.444V maximum.

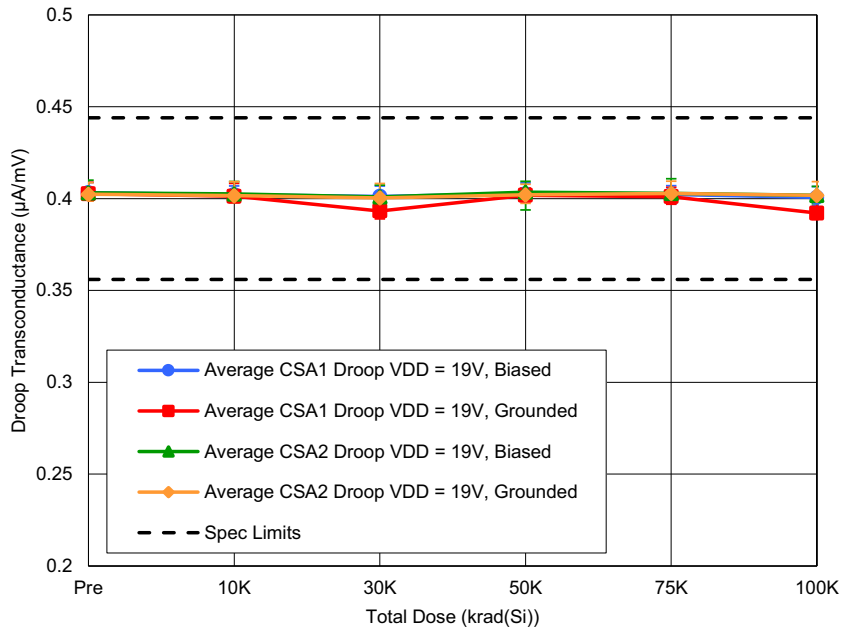

Figure 93. Average current sense amplifier droop transconductance,  $V_{DD} = 19V$ ,  $DROOP = 1.2V$ , as a function of LDR irradiation. The error bars represent the minimum and maximum measured values. The post-radiation datasheet limits are 0.356V minimum and 0.444V maximum.

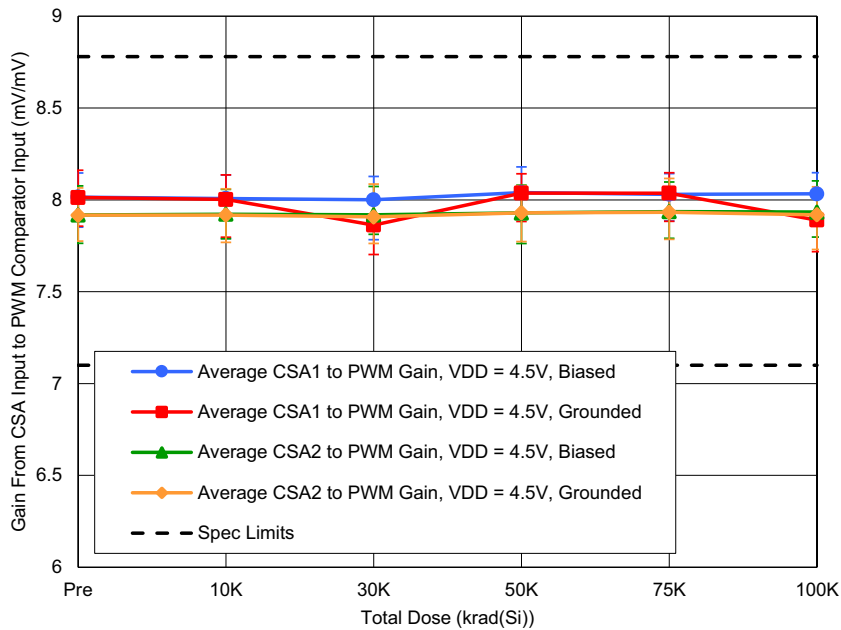

Figure 94. Average gain from CSA input to PWM comparator input,  $V_{DD} = 4.5V$ , as a function of LDR irradiation. The error bars represent the minimum and maximum measured values. The post-radiation datasheet limits are 7.10V minimum and 8.78V maximum.

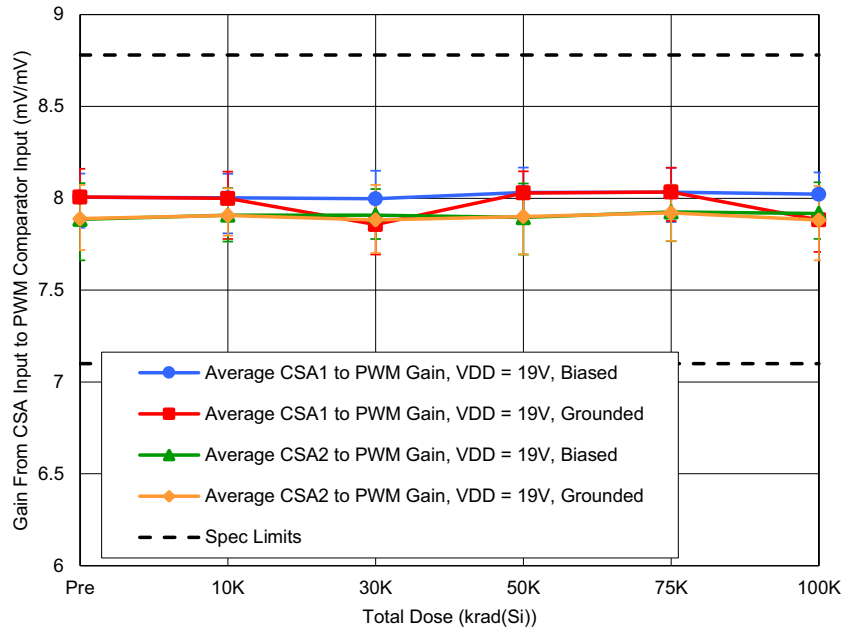

Figure 95. Average gain from CSA input to PWM comparator input,  $V_{DD} = 19V$ , as a function of LDR irradiation. The error bars represent the minimum and maximum measured values. The post-radiation datasheet limits are 7.10V minimum and 8.78V maximum.

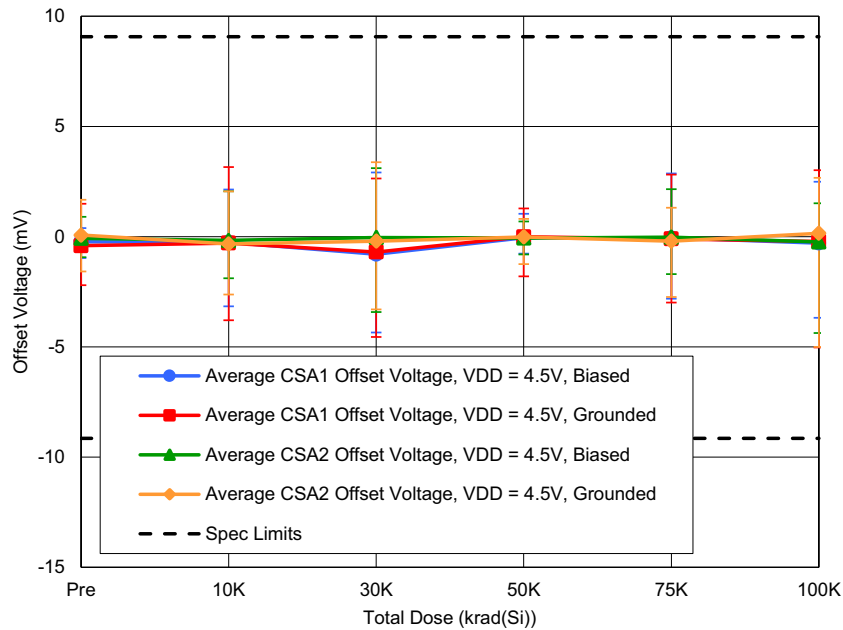

Figure 96. Average CSA offset voltage,  $V_{DD} = 4.5V$ , as a function of LDR irradiation. The error bars represent the minimum and maximum measured values. The post-radiation datasheet limits are -9.15mV minimum and 9.07mV maximum.

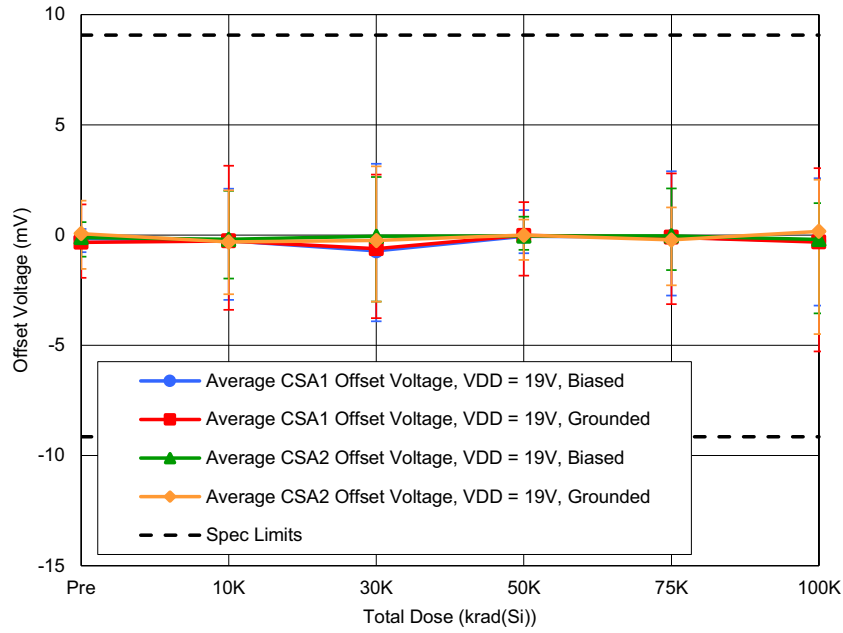

Figure 97. Average CSA offset voltage,  $V_{DD} = 19V$ , as a function of LDR irradiation. The error bars represent the minimum and maximum measured values. The post-radiation datasheet limits are  $-9.15mV$  minimum and  $9.07mV$  maximum.

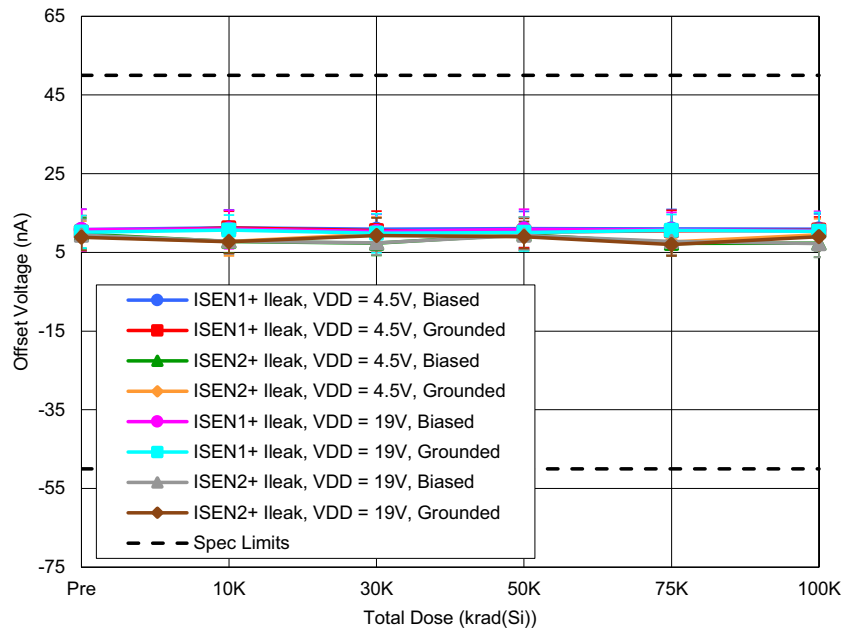

Figure 98. Average CSA positive input leakage current,  $V_{DD} = 4.5V, 19V$ , as a function of LDR irradiation. The error bars represent the minimum and maximum measured values. The post-radiation datasheet limits are  $-50nA$  minimum and  $50nA$  maximum.

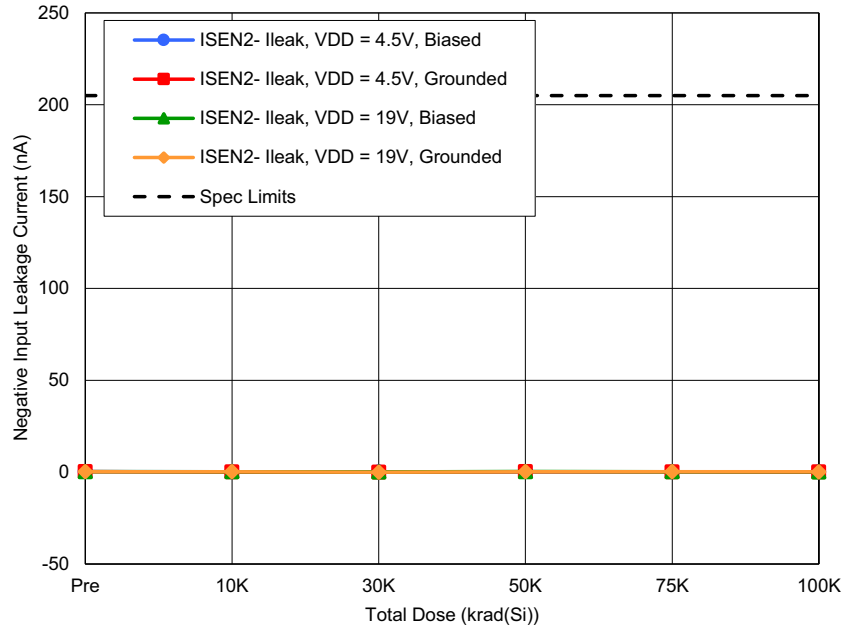

Figure 99. Average CSA negative input leakage current,  $V_{DD} = 4.5V, 19V, V_{CM} = 0.6V$ , as a function of LDR irradiation. The error bars represent the minimum and maximum measured values. The post-radiation datasheet limit is 205nA maximum.

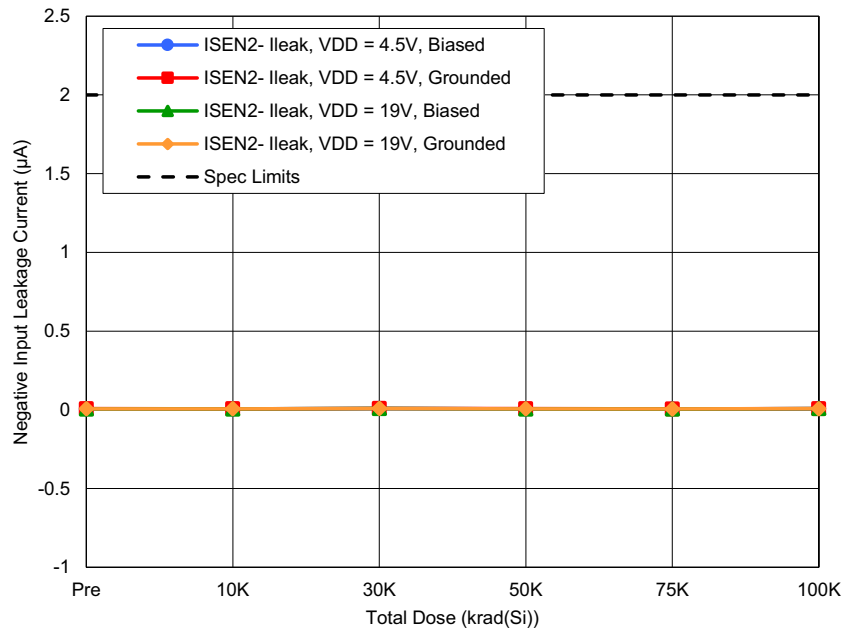

Figure 100. Average CSA negative input leakage current,  $V_{DD} = 4.5V, 19V, V_{CM} = 19V$ , as a function of LDR irradiation. The error bars represent the minimum and maximum measured values. The post-radiation datasheet limit is 2µA maximum.

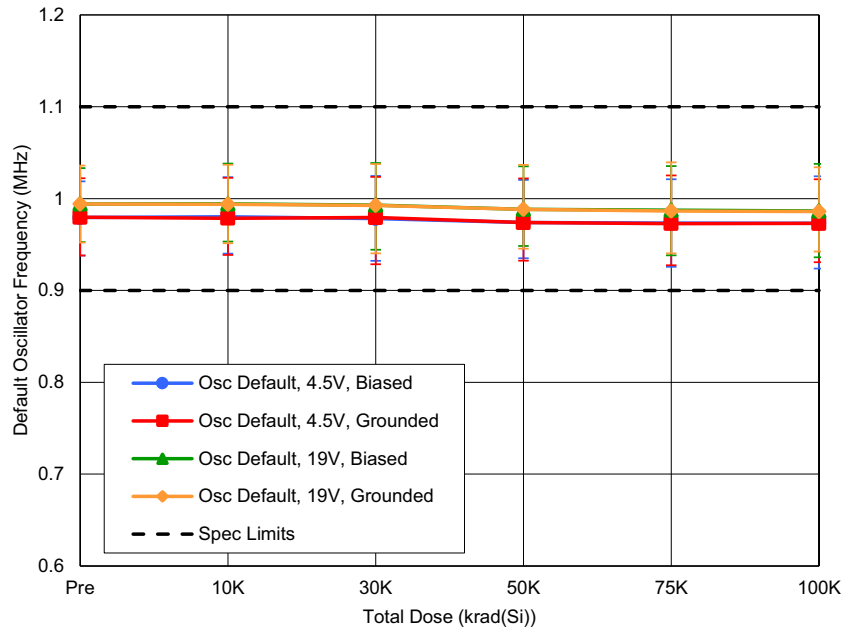

Figure 101. Average default oscillator frequency,  $V_{DD} = 4.5V, 19V$ , as a function of LDR irradiation. The error bars represent the minimum and maximum measured values. The post-radiation datasheet limits are 0.90MHz minimum and 1.10MHz maximum.

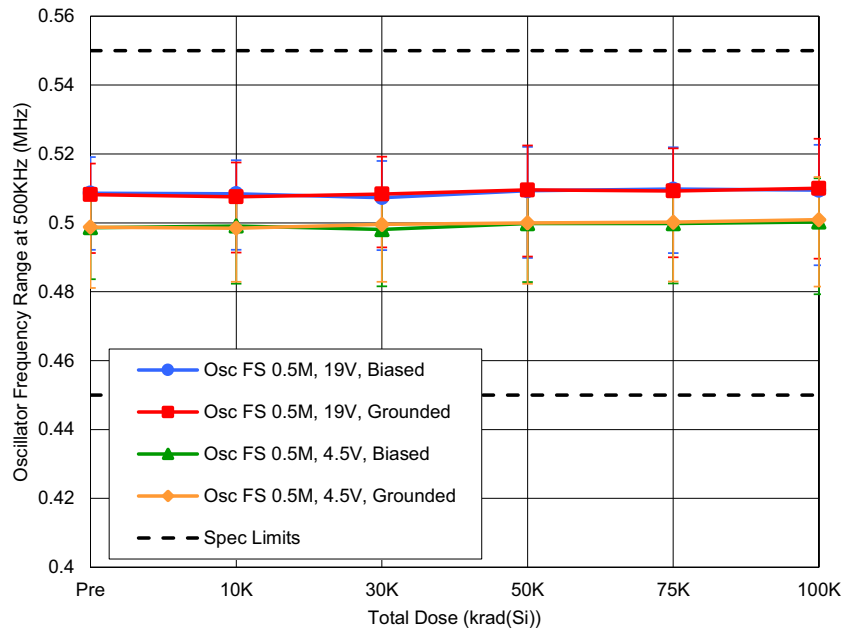

Figure 102. Average oscillator frequency range,  $V_{DD} = 4.5V, 19V, R_{FS} = 205k\Omega$ , as a function of LDR irradiation. The error bars represent the minimum and maximum measured values. The post-radiation datasheet limits are 0.45MHz minimum and 0.55MHz maximum.

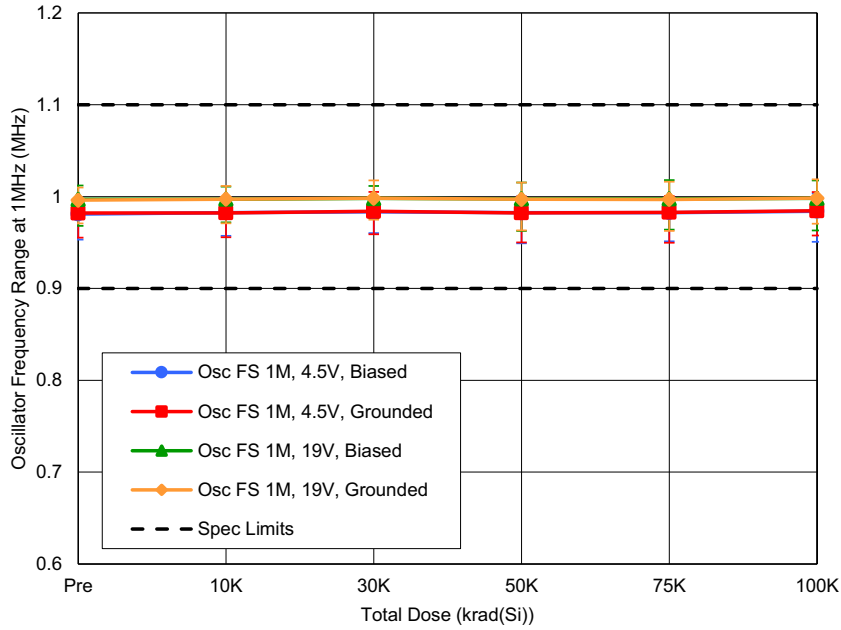

Figure 103. Average oscillator frequency range,  $V_{DD} = 4.5V, 19V, R_{FS} = 37k\Omega$ , as a function of LDR irradiation. The error bars represent the minimum and maximum measured values. The post-radiation datasheet limits are 0.90MHz minimum and 1.10MHz maximum.

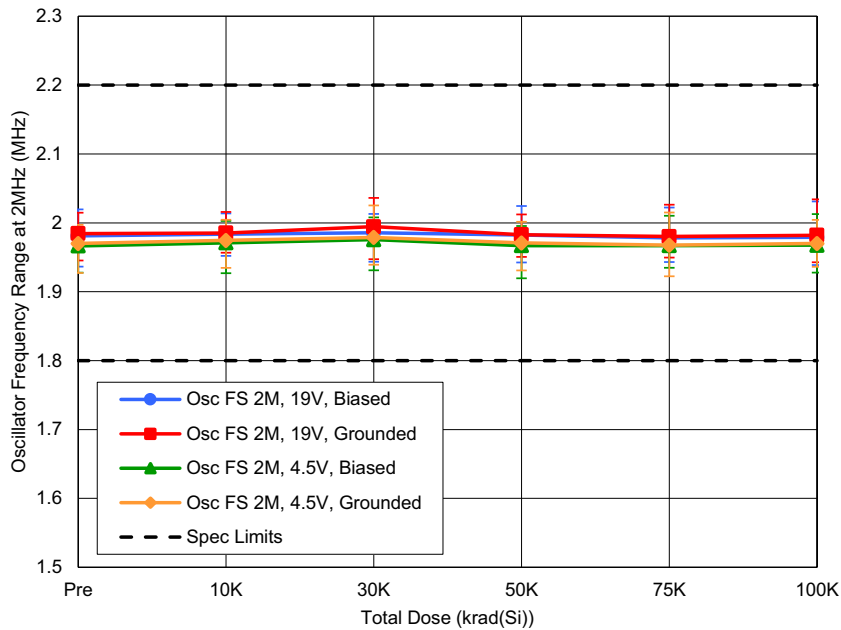

Figure 104. Average oscillator frequency range,  $V_{DD} = 4.5V, 19V, R_{FS} = 94.2k\Omega$ , as a function of LDR irradiation. The error bars represent the minimum and maximum measured values. The post-radiation datasheet limits are 1.80MHz minimum and 2.20MHz maximum.

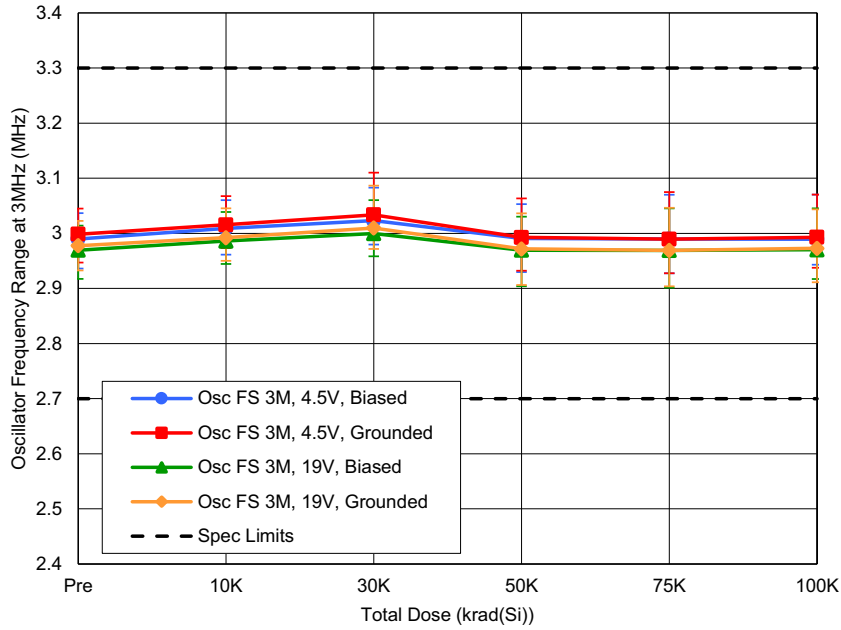

Figure 105. Average oscillator frequency range,  $V_{DD} = 4.5V, 19V, R_{FS} = 16.7k\Omega$ , as a function of LDR irradiation. The error bars represent the minimum and maximum measured values. The post-radiation datasheet limits are 2.70MHz minimum and 3.30MHz maximum.

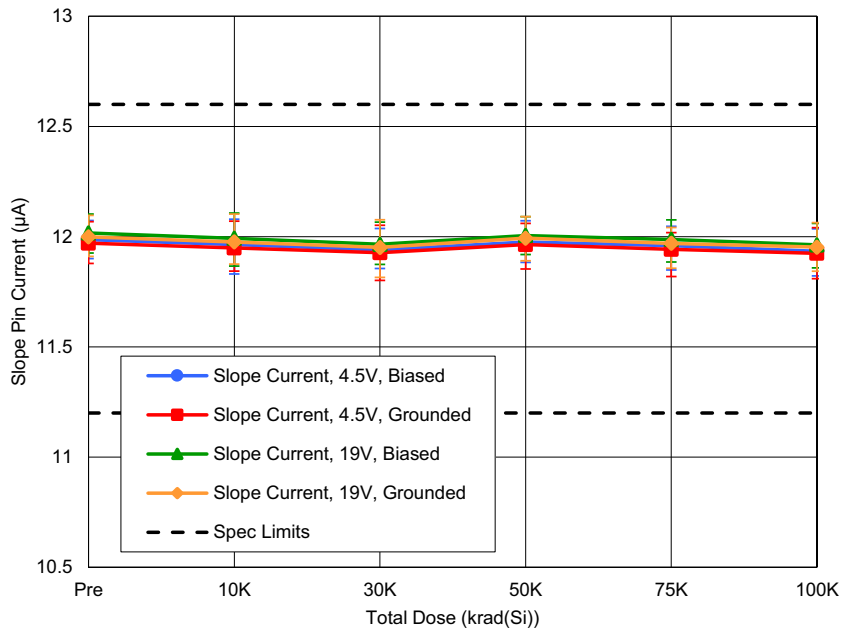

Figure 106. Average slope pin current,  $V_{DD} = 4.5V, 19V$ , as a function of LDR irradiation. The error bars represent the minimum and maximum measured values. The post-radiation datasheet limits are 11.2µA minimum and 12.6µA maximum.

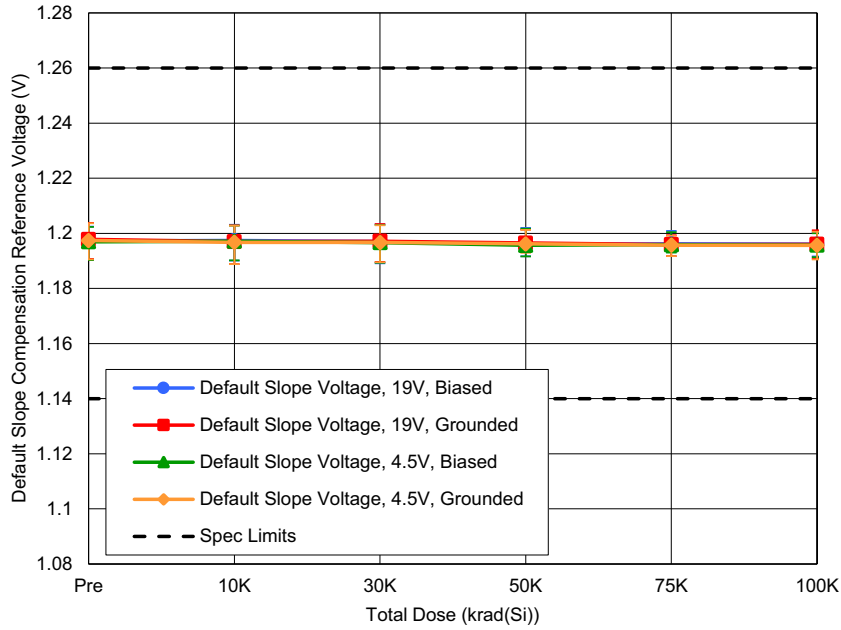

Figure 107. Average default slope compensation reference voltage,  $V_{DD} = 4.5V, 19V$ , as a function of LDR irradiation. The error bars represent the minimum and maximum measured values. The post-radiation datasheet limits are 1.14V minimum and 1.26V maximum.

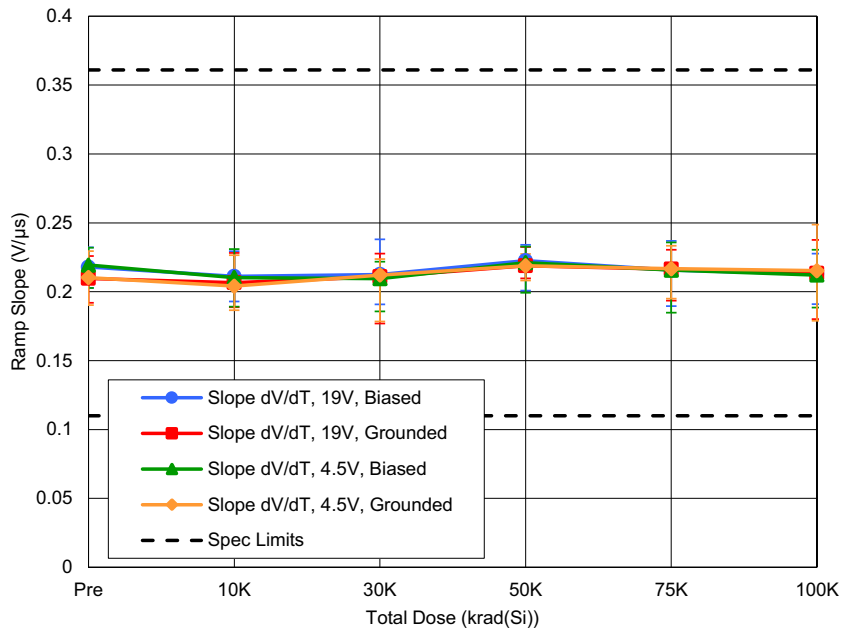

Figure 108. Average ramp slope,  $V_{DD} = 4.5V, 19V$ , as a function of LDR irradiation. The error bars represent the minimum and maximum measured values. The post-radiation datasheet limits are 0.11V/ $\mu s$  minimum and 0.361V/ $\mu s$  maximum.

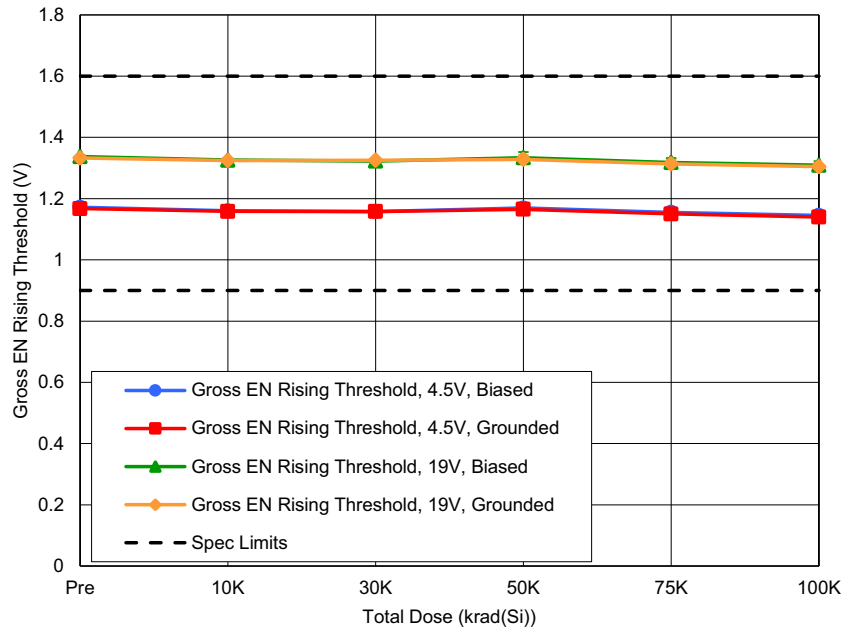

Figure 109. Average rising enable threshold (Gross),  $V_{DD} = 4.5V, 19V$ , as a function of LDR irradiation. The error bars represent the minimum and maximum measured values. The post-radiation datasheet limits are 0.9V minimum and 1.6V maximum.

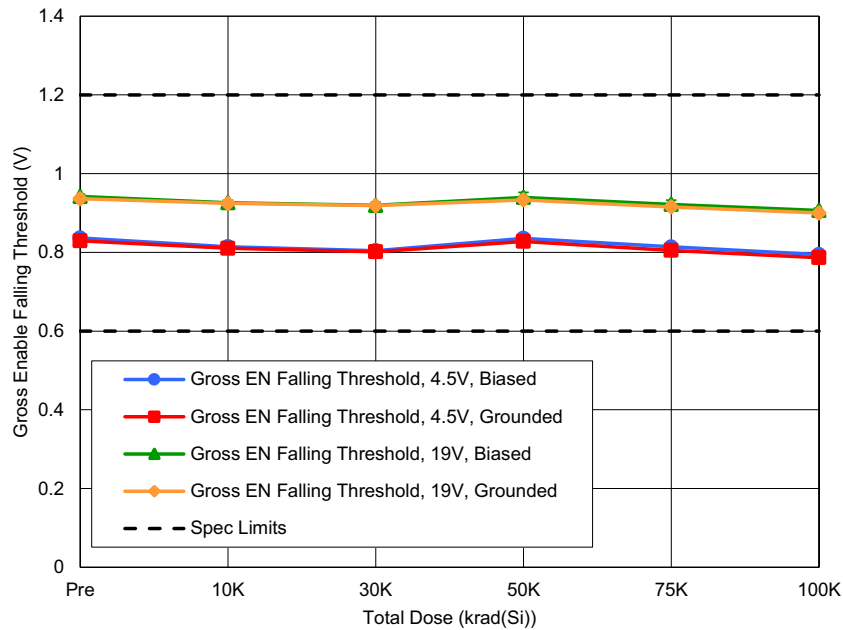

Figure 110. Average falling enable threshold (Gross),  $V_{DD} = 4.5V, 19V$ , as a function of LDR irradiation. The error bars represent the minimum and maximum measured values. The post-radiation datasheet limits are 0.6V minimum and 1.2V maximum.

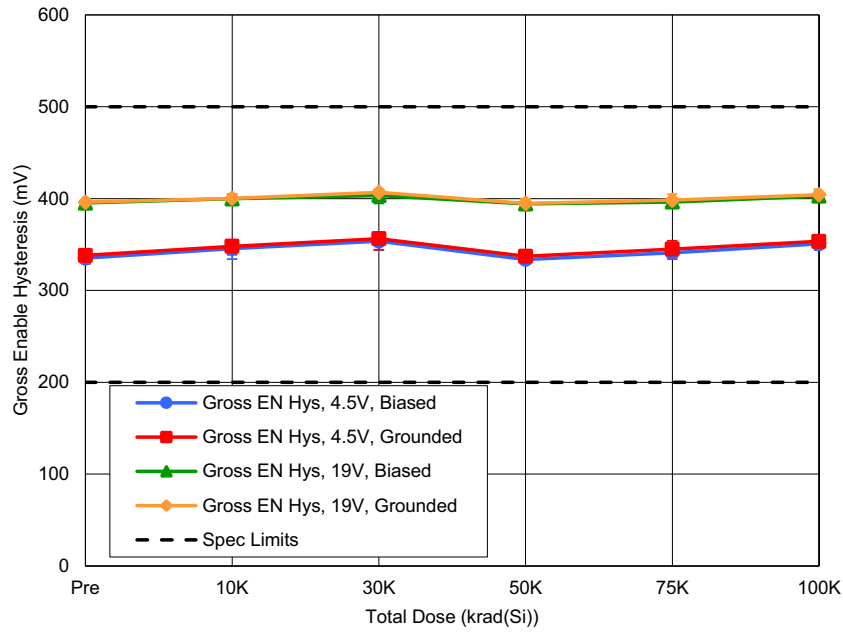

Figure 111. Average enable threshold hysteresis (Gross),  $V_{DD} = 4.5V, 19V$ , as a function of LDR irradiation. The error bars represent the minimum and maximum measured values. The post-radiation datasheet limits are 200mV minimum and 500mV maximum.

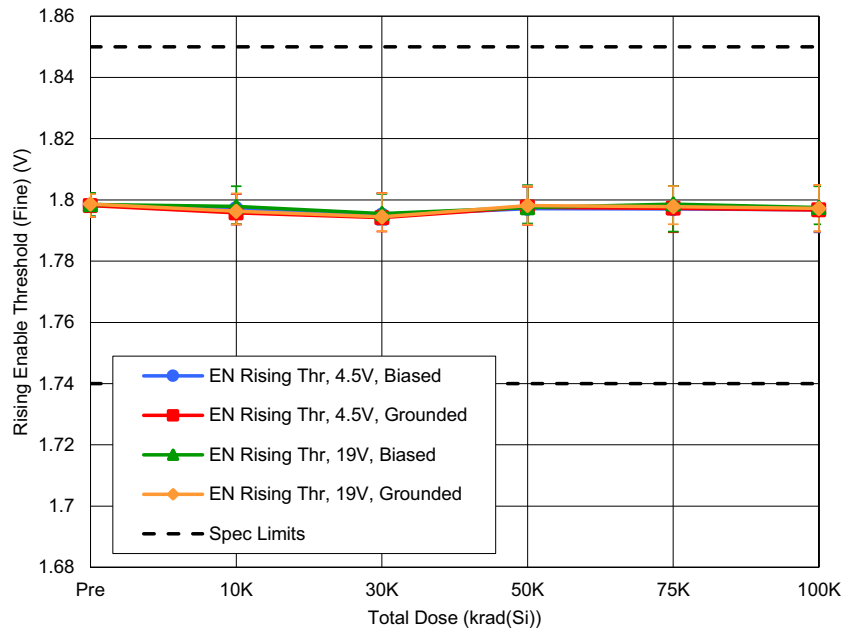

Figure 112. Average rising enable threshold (Fine),  $V_{DD} = 4.5V, 19V$ , as a function of LDR irradiation. The error bars represent the minimum and maximum measured values. The post-radiation datasheet limits are 1.74V minimum and 1.85V maximum.

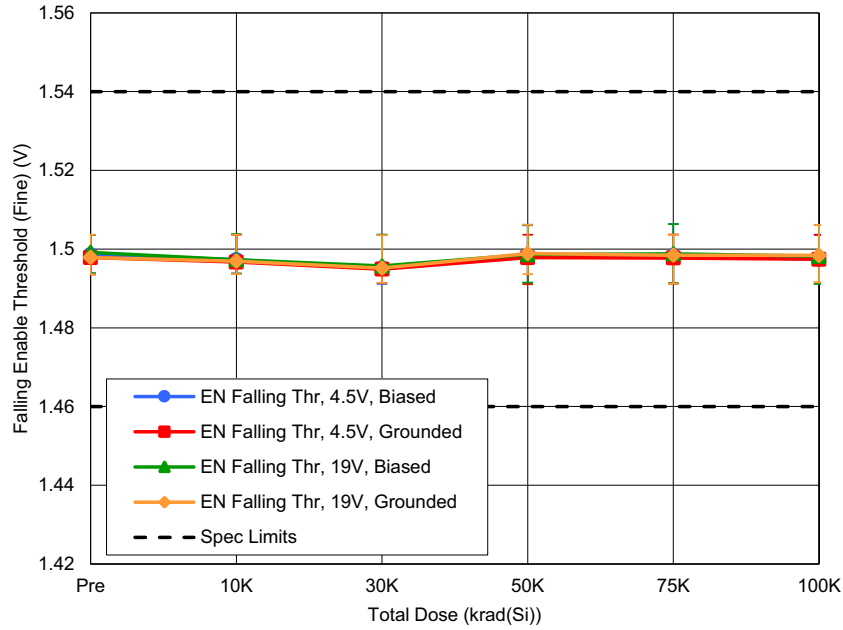

Figure 113. Average falling enable threshold (Fine),  $V_{DD} = 4.5V, 19V$ , as a function of LDR irradiation. The error bars represent the minimum and maximum measured values. The post-radiation datasheet limits are 1.46V minimum and 1.54V maximum.

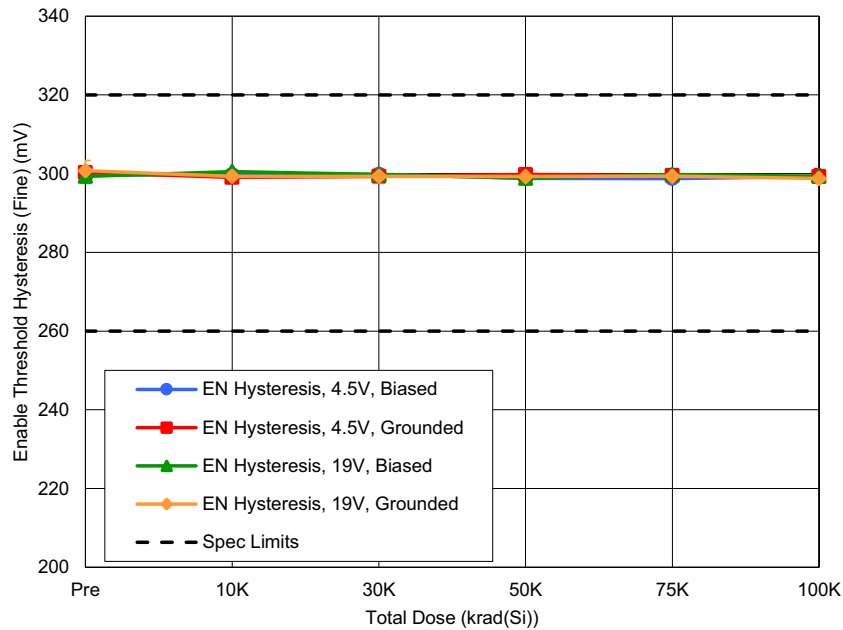

Figure 114. Average enable threshold hysteresis (Fine),  $V_{DD} = 4.5V, 19V$ , as a function of LDR irradiation. The error bars represent the minimum and maximum measured values. The post-radiation datasheet limits are 260mV minimum and 320mV maximum.

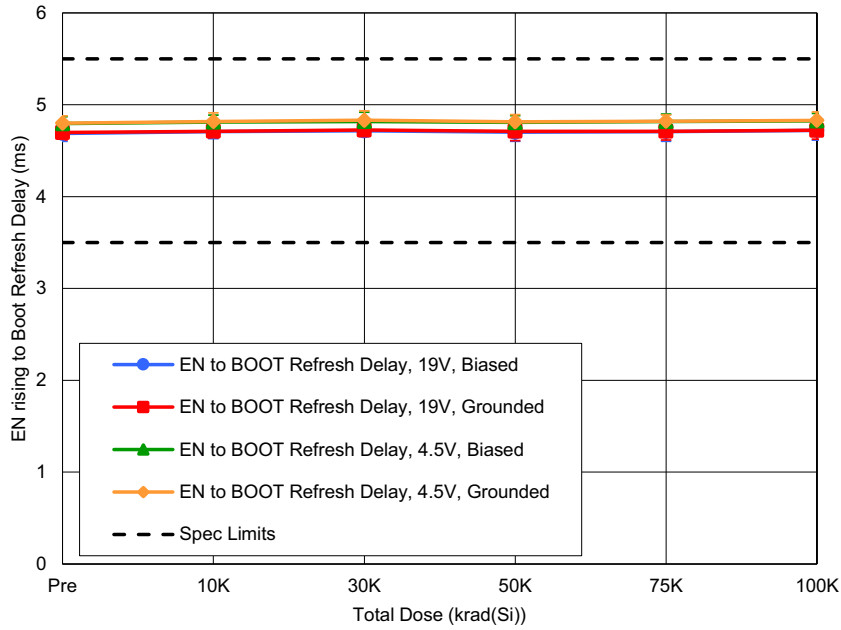

Figure 115. Average enable rising to BOOT refresh delay,  $V_{DD} = 4.5V, 19V$ , as a function of LDR irradiation. The error bars represent the minimum and maximum measured values. The post-radiation datasheet limits are 3.5ms minimum and 5.5ms maximum.

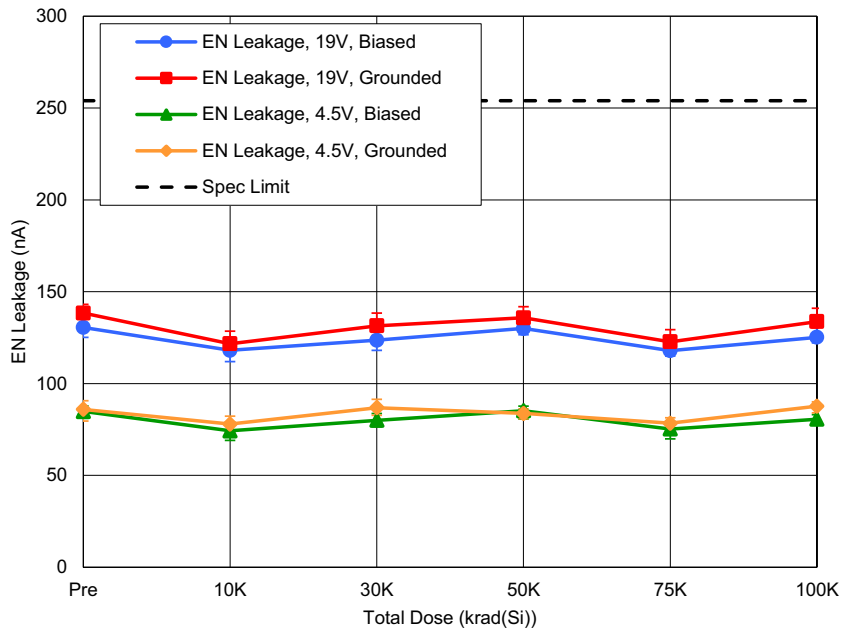

Figure 116. Average enable leakage,  $V_{DD} = 4.5V, 19V$ , as a function of LDR irradiation. The error bars represent the minimum and maximum measured values. The post-radiation datasheet limit is 254nA maximum.

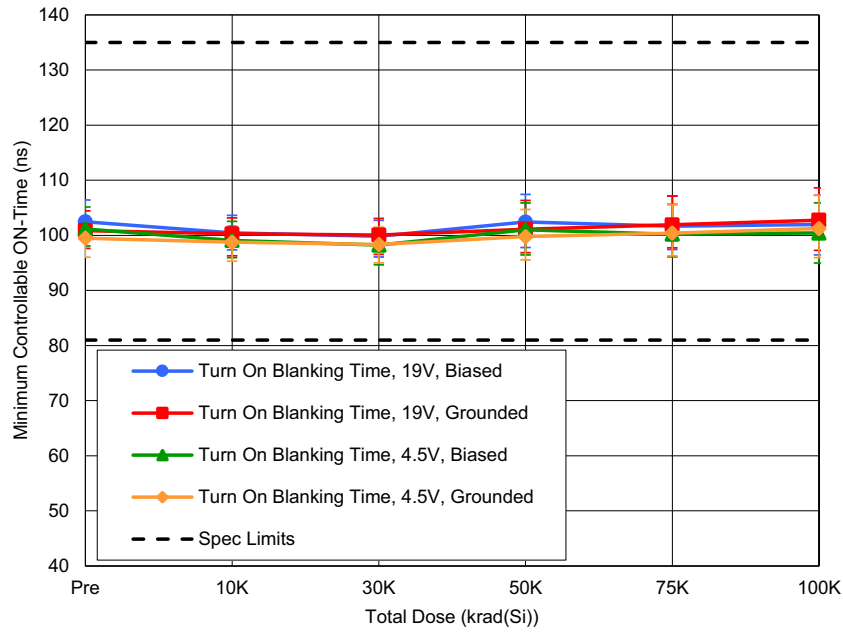

Figure 117. Average minimum controllable ON-Time,  $V_{DD} = 4.5V, 19V$ , as a function of LDR irradiation. The error bars represent the minimum and maximum measured values. The post-radiation datasheet limits are 81ns minimum and 135ns maximum.

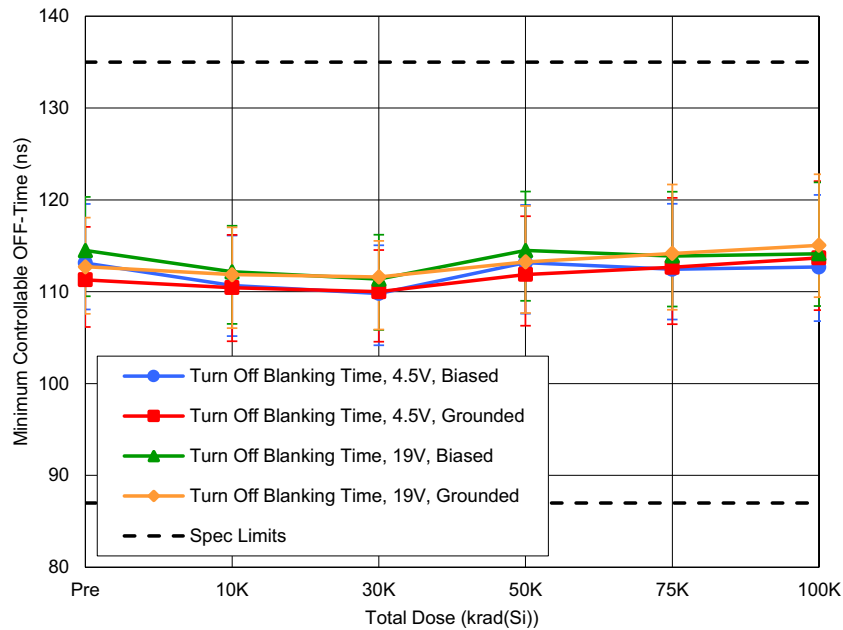

Figure 118. Average minimum controllable OFF-Time,  $V_{DD} = 4.5V, 19V$ , as a function of LDR irradiation. The error bars represent the minimum and maximum measured values. The post-radiation datasheet limits are 87ns minimum and 135ns maximum.

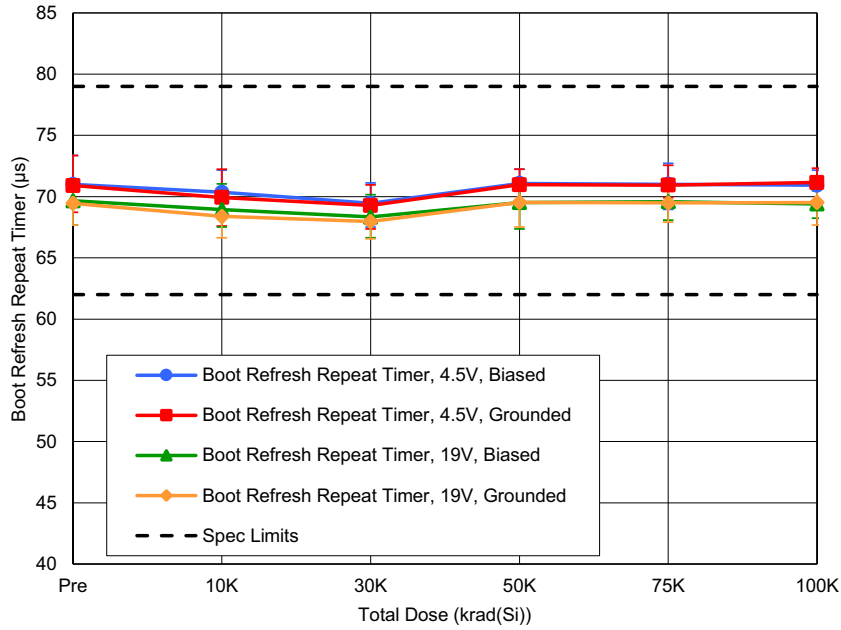

Figure 119. Average Boot refresh repeat timer,  $V_{DD} = 4.5V, 19V$ , as a function of LDR irradiation. The error bars represent the minimum and maximum measured values. The post-radiation datasheet limits are  $62\mu s$  minimum and  $79\mu s$  maximum.

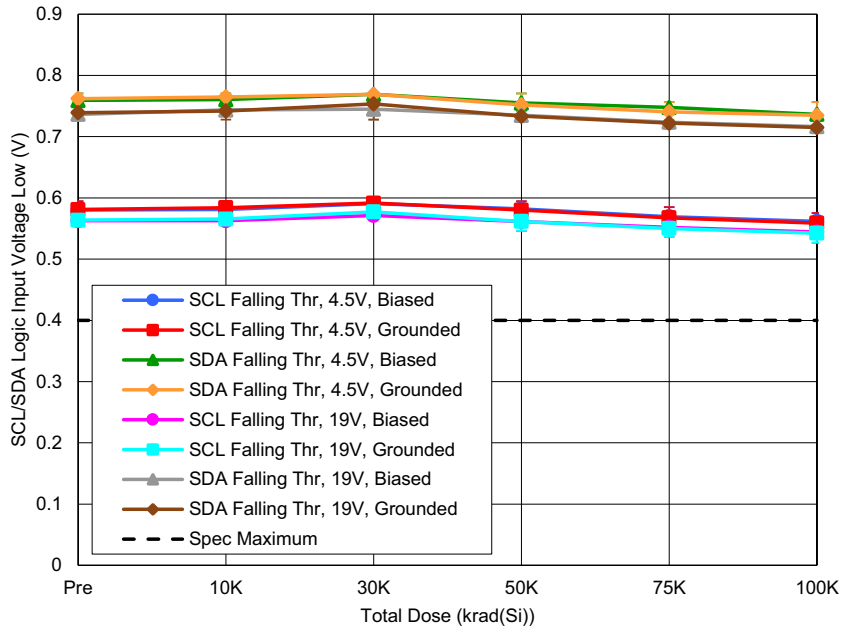

Figure 120. Average SCL/SDA logic input voltage low,  $V_{DD} = 4.5V, 19V$ , as a function of LDR irradiation. The error bars represent the minimum and maximum measured values. The post-radiation datasheet limit is  $0.4V$  maximum.

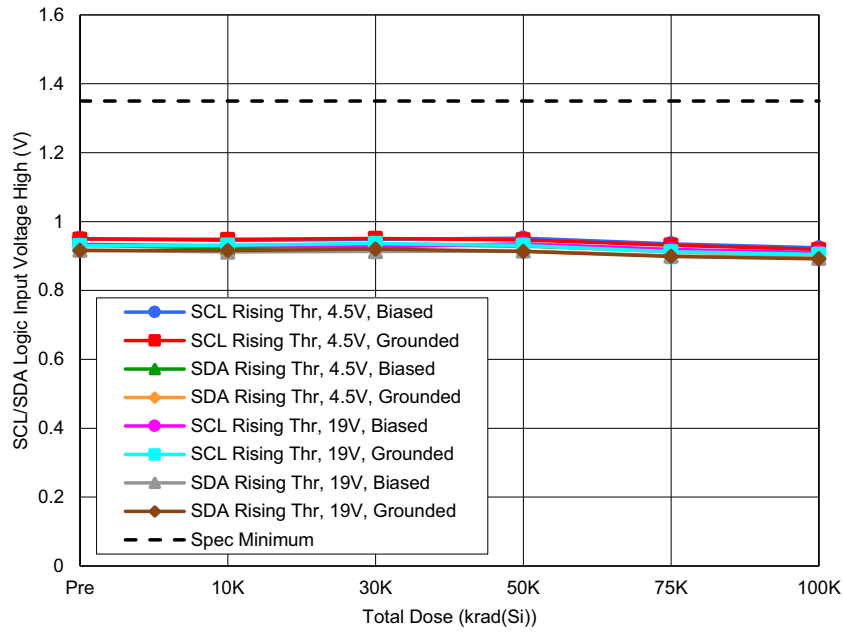

Figure 121. Average SCL/SDA logic input voltage high,  $V_{DD} = 4.5V, 19V$ , as a function of LDR irradiation. The error bars represent the minimum and maximum measured values. The post-radiation datasheet limit is 1.35V minimum.

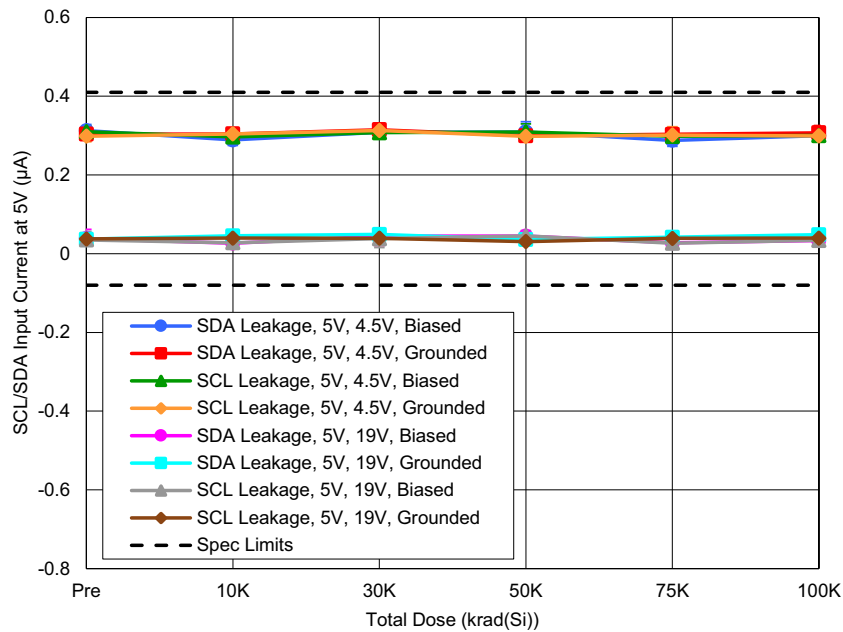

Figure 122. Average SCL/SDA leakage current at 5V,  $V_{DD} = 4.5V, 19V$ , as a function of LDR irradiation. The error bars represent the minimum and maximum measured values. The post-radiation datasheet limits are  $-0.08\mu A$  minimum and  $0.41\mu A$  maximum.

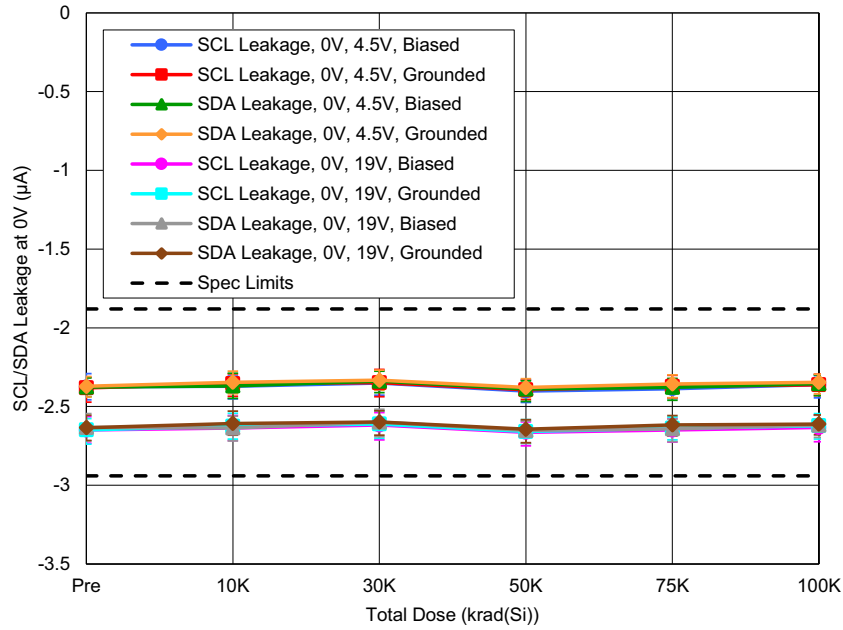

Figure 123. Average SCL/SDA leakage current at 0V,  $V_{DD} = 4.5V, 19V$ , as a function of LDR irradiation. The error bars represent the minimum and maximum measured values. The post-radiation datasheet limits are  $-2.94\mu A$  minimum and  $-1.88\mu A$  maximum.

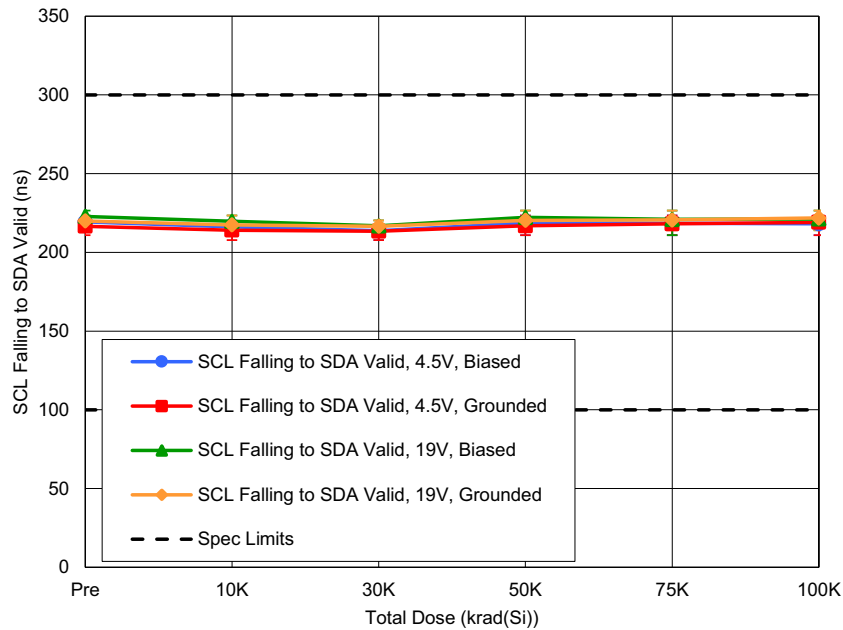

Figure 124. Average SCL falling edge to SDA valid time,  $V_{DD} = 4.5V, 19V$ , as a function of LDR irradiation. The error bars represent the minimum and maximum measured values. The post-radiation datasheet limits are 100ns minimum and 300ns maximum.



## A. Reported Parameters

Table 2 lists the key parameters that are considered indicative of part performance. These parameters are plotted in Figure 3 through Figure 124. All limits are taken from the ISL73849SLH Datasheet.

Table 2. ISL73849SLH Key Parameters ( $T_A = 25^\circ\text{C}$ )

Fig.	Parameter	Symbol	Conditions	Low Limit	High Limit	Unit	
3	Rising VDD UVLO	$VDD_{UV(R)}$	EN = 3.3V	4.05	4.4	V	
	Falling VDD UVLO	$VDD_{UV(F)}$		3.85	4.1	V	
4	VDD UVLO Hysteresis	$VDD_{UV(HYS)}$	EN = 3.3V	150	300	mV	
5	Operating Supply Current	$I_{DDO}$	VDD = 4.5V, 12V, 19V, EN = 3.3V, $f_{SW} = 500\text{kHz}$ , $C_L = 100\text{pF}$	18	25	mA	
6	Shutdown Supply Current	$I_{DDSD}$	VDD = 19V, EN = GND	-	35	$\mu\text{A}$	
7	Output Range	$V_{CC}$	VDD = 6.0V, 19V; $I_{OUT} = 0\text{mA}, 20\text{mA}$	4.7	5.3	V	
8	Dropout Voltage	$V_{CCDO}$	VDD = 4.5V, $I_{OUT} = 50\text{mA}$	85	476	mV	
9	Rising VCC UVLO	$VCC_{UV(R)}$	EN = 3.3V	3.39	3.70	V	
	Falling VCC UVLO	$VCC_{UV(F)}$		3.2	3.5	V	
10	VCC UVLO Hysteresis	$VCC_{UV(HYS)}$	EN = 3.3V	124	300	mV	
11	VCC Foldback Current	$I_{CC-SC}$	VDD = 19V, VCC = 0V, EN = 1.6V	40	90	mA	
12	VCC Overcurrent Limit	$I_{CC-CL}$	VDD = 19V, VCC = 4.3V, EN = 1.6V	75	130	mA	
13	Set Point Voltage (VREF = VDROOP, VSEN1 = VSEN2 = 0mV, 50mV)	VFB+	PMBus command set to 25dec for 0.2V	0.194	0.206	V	
14			PMBus command left at default 74dec for 0.592V on power up or enable	0.585	0.597	V	
15			PMBus command set to 75dec for 0.6V	0.594	0.605	V	
16			PMBus command set to 150dec for 1.2V	1.194	1.207	V	
17							
18							
19							
20							
21	Set Point Accuracy Over Line Delta	VFB+	VREF = VDROOP = 1V, VSEN1 = VSEN2 = 200mV	-2.57	2.12	mV	
22			VREF = VDROOP = 2V, VSEN1 = VSEN2 = 0mV				
23	Set Point Accuracy Over Load Delta V <sub>DD</sub> = 4.5V, 19V, V <sub>REF</sub> = VDROOP = 1V, 2V, VSEN1 = VSEN2 = 0mV	VFB+	PMBus set for 200mV	-2.20	3.57	mV	
24			PMBus set for 592mV				
25			PMBus set for 600mV				
26			PMBus set for 1.2V				
27	FB Input Bias Current Positive	$I_{FB-BIAS-P}$	V(FB+) = 0.6V, V(FB-) = 0V	-50	50	nA	
28	FB Input Bias Current Negative	$I_{FB-BIAS-N}$	V(FB+) = 0.6V, V(FB-) = 0V	-388	499	$\mu\text{A}$	
29	Soft-Start Time	$T_{SS}$	Time for the internal SS node to reach 0.9V when VREF=VDROOP=0.6V. SS_CONFIG (E5h) PMBus command left at default 011b for 8ms on power-up and enable	7	10	ms	
30	VOUT Transition	-	Time for VREF = VDROOP to transition from 0.2V to 0.8V. Measurement is taken at 0.4V to 0.6V. VOUT_TRANSITION_RATE (27h) PMBus command left at default 100b on power-up and enable.	164	240	mV/ms	

Table 2. ISL73849SLH Key Parameters (T<sub>A</sub> = 25°C) (Cont.)

Fig.	Parameter	Symbol	Conditions	Low Limit	High Limit	Unit
31	Peak Positive Current Limit (Channel 1 and Channel 2)	V <sub>POC1</sub>	V <sub>DD</sub> = 19V, V <sub>CM</sub> = 0.6V, OC_TH (E1h) PMBus command set to 000b	62.0	82.5	mV
32			V <sub>DD</sub> = 4.5V, V <sub>CM</sub> = 0.6V, OC_TH (E1h) PMBus command set to 000b			
33			V <sub>DD</sub> = 4.5V, V <sub>CM</sub> = 19V, OC_TH (E1h) PMBus command set to 000b			
34			V <sub>DD</sub> = 19V, V <sub>CM</sub> = 0.6V, OC_TH (E1h) PMBus command set to 001b	67.0	86.9	mV
35			V <sub>DD</sub> = 4.5V, V <sub>CM</sub> = 0.6V, OC_TH (E1h) PMBus command set to 001b			
36			V <sub>DD</sub> = 4.5V, V <sub>CM</sub> = 19V, OC_TH (E1h) PMBus command set to 001b			
37			V <sub>DD</sub> = 19V, V <sub>CM</sub> = 0.6V, OC_TH (E1h) PMBus command set to 010b	71.9	92.6	mV
38			V <sub>DD</sub> = 4.5V, V <sub>CM</sub> = 0.6V, OC_TH (E1h) PMBus command set to 010b			
39			V <sub>DD</sub> = 4.5V, V <sub>CM</sub> = 19V, OC_TH (E1h) PMBus command set to 010b			
40			V <sub>DD</sub> = 19V, V <sub>CM</sub> = 0.6V, OC_TH (E1h) PMBus command set to 011b	78.4	98.4	mV
41			V <sub>DD</sub> = 4.5V, V <sub>CM</sub> = 0.6V, OC_TH (E1h) PMBus command set to 011b			
42			V <sub>DD</sub> = 4.5V, V <sub>CM</sub> = 19V, OC_TH (E1h) PMBus command set to 011b			
43			V <sub>DD</sub> = 19V, V <sub>CM</sub> = 0.6V, OC_TH (E1h) PMBus command set to 100b	26.0	44.6	mV
44			V <sub>DD</sub> = 4.5V, V <sub>CM</sub> = 0.6V, OC_TH (E1h) PMBus command set to 100b			
45			V <sub>DD</sub> = 4.5V, V <sub>CM</sub> = 19V, OC_TH (E1h) PMBus command set to 100b			
46			V <sub>DD</sub> = 19V, V <sub>CM</sub> = 0.6V, OC_TH (E1h) PMBus command set to 101b	28.4	46.9	mV
47			V <sub>DD</sub> = 4.5V, V <sub>CM</sub> = 0.6V, OC_TH (E1h) PMBus command set to 101b			
48			V <sub>DD</sub> = 4.5V, V <sub>CM</sub> = 19V, OC_TH (E1h) PMBus command set to 101b			
49			V <sub>DD</sub> = 19V, V <sub>CM</sub> = 0.6V, OC_TH (E1h) PMBus command set to 110b	30.5	49.8	mV
50			V <sub>DD</sub> = 4.5V, V <sub>CM</sub> = 0.6V, OC_TH (E1h) PMBus command set to 110b			
51			V <sub>DD</sub> = 4.5V, V <sub>CM</sub> = 19V, OC_TH (E1h) PMBus command set to 110b			
52			V <sub>DD</sub> = 19V, V <sub>CM</sub> = 0.6V, OC_TH (E1h) PMBus command set to 111b	33.7	52.7	mV
53			V <sub>DD</sub> = 4.5V, V <sub>CM</sub> = 0.6V, OC_TH (E1h) PMBus command set to 111b			
54			V <sub>DD</sub> = 4.5V, V <sub>CM</sub> = 19V, OC_TH (E1h) PMBus command set to 111b			

Table 2. ISL73849SLH Key Parameters ( $T_A = 25^\circ\text{C}$ ) (Cont.)

Fig.	Parameter	Symbol	Conditions	Low Limit	High Limit	Unit
55	Peak Positive Overcurrent (Channel 1 and Channel 2)	$V_{POC2}$	$V_{DD} = 19\text{V}$ , $V_{CM} = 0.6\text{V}$ , OC_TH (E1h) PMBus command set to 000-011b	83.9	111	mV
56			$V_{DD} = 4.5\text{V}$ , $V_{CM} = 0.6\text{V}$ , OC_TH (E1h) PMBus command set to 000-011b			
57			$V_{DD} = 4.5\text{V}$ , $V_{CM} = 19\text{V}$ , OC_TH (E1h) PMBus command set to 000-011b			
58			$V_{DD} = 19\text{V}$ , $V_{CM} = 19\text{V}$ , OC_TH (E1h) PMBus command set to 000-011b			
59			$V_{DD} = 19\text{V}$ , $V_{CM} = 0.6\text{V}$ , OC_TH (E1h) PMBus command set to 100-111b	35.9	60.2	
60			$V_{DD} = 4.5\text{V}$ , $V_{CM} = 0.6\text{V}$ , OC_TH (E1h) PMBus command set to 100-111b			
61			$V_{DD} = 4.5\text{V}$ , $V_{CM} = 19\text{V}$ , OC_TH (E1h) PMBus command set to 100-111b			
62			$V_{DD} = 19\text{V}$ , $V_{CM} = 19\text{V}$ , OC_TH (E1h) PMBus command set to 100-111b			
63	Peak Negative Overcurrent (Channel 1 and Channel 2)	$V_{NOC}$	$V_{DD} = 19\text{V}$ , $V_{CM} = 0.6\text{V}$ , OC_TH (E1h) PMBus command set to 000-011b	-83	-61.7	mV
64			$V_{DD} = 4.5\text{V}$ , $V_{CM} = 0.6\text{V}$ , OC_TH (E1h) PMBus command set to 000-011b			
65			$V_{DD} = 4.5\text{V}$ , $V_{CM} = 19\text{V}$ , OC_TH (E1h) PMBus command set to 000-011b			
66			$V_{DD} = 19\text{V}$ , $V_{CM} = 19\text{V}$ , OC_TH (E1h) PMBus command set to 000-011b			
67			$V_{DD} = 19\text{V}$ , $V_{CM} = 0.6\text{V}$ , OC_TH (E1h) PMBus command set to 100-111b	-47.5	-23.0	
68			$V_{DD} = 4.5\text{V}$ , $V_{CM} = 0.6\text{V}$ , OC_TH (E1h) PMBus command set to 100-111b			
69			$V_{DD} = 4.5\text{V}$ , $V_{CM} = 19\text{V}$ , OC_TH (E1h) PMBus command set to 100-111b			
70			$V_{CM} = 0.6\text{V}$ , $19\text{V}$ , OC_TH (E1h) PMBus command set to 100b-111b			
71	Overvoltage Threshold Rising	$V_{(FB, OV)}$	VOUT_OV_LIMIT (E3h) PMBus command left at default 010b for 110% on power-up and enable	107	113	%
72	Overvoltage Threshold Falling	$V_{(FB, OV)}$	VOUT_OV_LIMIT (E3h) PMBus command left at default 010b for 110% on power-up and enable	105	113	%
73	Overvoltage Threshold Hysteresis	$V_{(FB, OV)}$	VOUT_OV_LIMIT (E3h) PMBus command left at default 010b for 110% on power-up and enable	1.4	3.6	%
74	Undervoltage Threshold Rising	$V_{(FB, UV)}$	VOUT_UV_LIMIT (E4h) PMBus command left at default 101b for 90% on power-up and enable	87	93	%
75	Undervoltage Threshold Falling	$V_{(FB, UV)}$	VOUT_UV_LIMIT (E4h) PMBus command left at default 101b for 90% on power-up and enable	87	95	%
76	Undervoltage Threshold Hysteresis	$V_{(FB, UV)}$	VOUT_UV_LIMIT (E4h) PMBus command left at default 101b for 90% on power-up and enable	1.46	3.70	%
77	UV/OV/Severe Propagation Delay	$t_{DEGLITCH}$	$V_{(FB+), (FB-)} = 0.6\text{V} + \text{Pulse}$ to initiate the Severe UV/OV fault condition. Measure the delay from fault to PWMx going mid-scale.	8	16	$\mu\text{s}$
78	Hiccup Retry Delay	$t_{HIC-DLY}$	SS_CONFIG (E5h) PMBus command at default 011b for 8ms on power-up and enable.	9.6	14.0	ms
79	FLTb Drive Current	$I_{FLTb}$	FLTb = 400mV	20	75	mA

Table 2. ISL73849SLH Key Parameters ( $T_A = 25^\circ\text{C}$ ) (Cont.)

Fig.	Parameter	Symbol	Conditions	Low Limit	High Limit	Unit
80	FLTb Rising Threshold Voltage	$V_{FLTbMID}$	-	2.5	3.3	V
81	FLTb Falling Threshold Voltage	$V_{FLTbMID}$	-	1.6	2.55	V
82	FLTb Leakage Current	$V_{FLTbLKG}$	FLTb = 5V	-2	2	$\mu\text{A}$
83	Error Amp Transconductance	$g_{m-EA}$		3	4	$\text{mA/V}$
84	Error Amp Output Voltage Range	$V_{COMP(RNG)}$	$V_{DD} = 4.5\text{V}$	0.4	4.1	V
85			$V_{DD} = 19\text{V}$	0.4	4.6	V
86	Droop Transconductance $V(I_{SEN+} - I_{SEN-}) = 10\text{mV}$ , $50\text{mV}$ ; $V_{CM} = 0.6\text{V}$ , $19\text{V}$	$g_{m(CSA, DRP)}$	$V_{DD} = 4.5\text{V}$ , DROOP = 0.6V	0.368	0.423	$\mu\text{A/mV}$
87			$V_{DD} = 19\text{V}$ , DROOP = 0.6V			
88			$V_{DD} = 4.5\text{V}$ , DROOP = 0.2V	0.321	0.400	$\mu\text{A/mV}$
89			$V_{DD} = 19\text{V}$ , DROOP = 0.2V			
90			$V_{DD} = 4.5\text{V}$ , DROOP = 0.5V	0.328	0.454	$\mu\text{A/mV}$
91			$V_{DD} = 19\text{V}$ , DROOP = 0.5V			
92			$V_{DD} = 4.5\text{V}$ , DROOP = 1.2V	0.356	0.444	$\mu\text{A/mV}$
93			$V_{DD} = 19\text{V}$ , DROOP = 1.2V			
94	Gain from CSA Input to PWM Comparator Input	$A_{CSA-PWM}$	$V_{DD} = 4.5\text{V}$ , $V(I_{SEN+}, I_{SEN-}) = 50\text{mV}$	7.1	8.78	$\text{mV/mV}$
95			$V_{DD} = 19\text{V}$ , $V(I_{SEN+}, I_{SEN-}) = 50\text{mV}$			
96	Offset Voltage	$V_{OS(CSA)}$	$V_{DD} = 4.5\text{V}$	-9.15	9.07	mV
97			$V_{DD} = 19\text{V}$			
98	Positive Input Leakage Current	$I_{LKG+(CSA)}$	EN = 0V, $V_{CM} = 0.6\text{V}$ , $19\text{V}$	-50	50	nA
99	Negative Input Leakage Current	$I_{LKG-(CSA)}$	EN = 0V, $V_{CM} = 0.6\text{V}$	-	205	nA
100			EN = 0V, $V_{CM} = 19\text{V}$	-	2	$\mu\text{A}$
101	Default Oscillator Frequency	$f_{SW-D}$	$F_S = V_{CC}$ , $V_{DD} = 4.5\text{V}$ , $19\text{V}$	0.90	1.10	MHz
102	Oscillator Frequency Range EN = 5V, $R_{SYNC-O} = 100\text{k}\Omega$ to GND	$f_{SW-0.5M}$	$R_{FS} = 205\text{k}\Omega$	0.45	0.55	MHz
103		$f_{SW-1M}$	$R_{FS} = 94.2\text{k}\Omega$	0.90	1.10	MHz
104		$f_{SW-2M}$	$R_{FS} = 37\text{k}\Omega$	1.80	2.20	MHz
105		$f_{SW-3M}$	$R_{FS} = 16.7\text{k}\Omega$	2.70	3.30	MHz
106	Slope Pin Current	$I_{SLOPE}$	$V_{SLOPE} = 400\text{mV}$ , $V_{DD} = 4.5\text{V}$ , $19\text{V}$	11.2	12.6	$\mu\text{A}$
107	Default Slope Compensation Reference Voltage	$V_{SCMP\_DFLT}$	-	1.14	1.26	V
108	Ramp Slope	$V_{RAMP-SLOPE}$	$V_{SLOPE} = 1.2\text{V}$ , $V_{DD} = 19\text{V}$	0.110	0.361	$\text{V}/\mu\text{s}$
109	Rising Enable Threshold (Gross)	$V_{IH-EN-G}$	-	0.9	1.6	V
110	Falling Enable Threshold (Gross)	$V_{IL-EN-G}$	-	0.6	1.2	V
111	Enable Threshold Hysteresis (Gross)	$V_{HYS-EN-G}$	-	200	500	mV
112	Rising Enable Threshold (Fine)	$V_{IH-EN-G}$	-	1.74	1.85	V
113	Falling Enable Threshold (Fine)	$V_{IL-EN-G}$	-	1.46	1.54	V
114	Enable Threshold Hysteresis (Fine)	$V_{HYS-EN-G}$	-	260	320	mV
115	EN rising to Boot Refresh Delay	$t_{EN}$	-	3.5	5.5	ms
116	EN Leakage	$EN_{LK}$	$V_{DD} = EN = 19\text{V}$	-	254	nA
117	Minimum Controllable ON-Time	$t_{MINCTRLON}$	-	81	135	ns

Table 2. ISL73849SLH Key Parameters ( $T_A = 25^\circ\text{C}$ ) (Cont.)

Fig.	Parameter	Symbol	Conditions	Low Limit	High Limit	Unit
118	Minimum Controllable OFF-Time	$t_{\text{MINCTRLOFF}}$	-	87	135	ns
119	Boot Refresh Repeat Timer	$t_{\text{BOOT}}$	-	62	79	$\mu\text{s}$
120	SCL/SDA Logic Input Voltage Low	-	$I_{\text{OUT}} = -4\text{mA}$	-	0.4	V
121	SCL/SDA Logic Input Voltage High	-	-	1.35	-	V
122	Input Current	-	5V	-0.08	0.41	$\mu\text{A}$
123		-	0V	-2.94	-1.88	$\mu\text{A}$
124	SCL Falling Edge to SDA Valid Time	-	PMBus Frequency = 400kHz	100	300	ns

## IMPORTANT NOTICE AND DISCLAIMER

RENESAS ELECTRONICS CORPORATION AND ITS SUBSIDIARIES (“RENESAS”) PROVIDES TECHNICAL SPECIFICATIONS AND RELIABILITY DATA (INCLUDING DATASHEETS), DESIGN RESOURCES (INCLUDING REFERENCE DESIGNS), APPLICATION OR OTHER DESIGN ADVICE, WEB TOOLS, SAFETY INFORMATION, AND OTHER RESOURCES “AS IS” AND WITH ALL FAULTS, AND DISCLAIMS ALL WARRANTIES, EXPRESS OR IMPLIED, INCLUDING, WITHOUT LIMITATION, ANY IMPLIED WARRANTIES OF MERCHANTABILITY, FITNESS FOR A PARTICULAR PURPOSE, OR NON-INFRINGEMENT OF THIRD-PARTY INTELLECTUAL PROPERTY RIGHTS.

These resources are intended for developers who are designing with Renesas products. You are solely responsible for (1) selecting the appropriate products for your application, (2) designing, validating, and testing your application, and (3) ensuring your application meets applicable standards, and any other safety, security, or other requirements. These resources are subject to change without notice. Renesas grants you permission to use these resources only to develop an application that uses Renesas products. Other reproduction or use of these resources is strictly prohibited. No license is granted to any other Renesas intellectual property or to any third-party intellectual property. Renesas disclaims responsibility for, and you will fully indemnify Renesas and its representatives against, any claims, damages, costs, losses, or liabilities arising from your use of these resources. Renesas' products are provided only subject to Renesas' Terms and Conditions of Sale or other applicable terms agreed to in writing. No use of any Renesas resources expands or otherwise alters any applicable warranties or warranty disclaimers for these products.

(Disclaimer Rev.1.01)

### Corporate Headquarters

TOYOSU FORESIA, 3-2-24 Toyosu,  
Koto-ku, Tokyo 135-0061, Japan  
[www.renesas.com](http://www.renesas.com)

### Trademarks

Renesas and the Renesas logo are trademarks of Renesas Electronics Corporation. All trademarks and registered trademarks are the property of their respective owners.

### Contact Information

For further information on a product, technology, the most up-to-date version of a document, or your nearest sales office, please visit [www.renesas.com/contact-us/](http://www.renesas.com/contact-us/).