

RC38312Ax/RC38x08Ax (FC3W) ITU-T G.8262, G.8262.1

This report describes the compliance testing results of the Renesas the RC38312Ax / RC38x08Ax (FemtoClock™3 Wireless/FC3W) PLLs to ITU-T G.8262 option 1, ITU-T G.8262 option 2, and ITU-T G.8262.1. Also described are the compliance testing results of eEEC standards for phase transients due to synchronization rearrangement operations, phase transient tolerance, wander transfer, wander generation, and holdover.

Contents

1. Description of Tests and Setup	7
2. Test Equipment Information	8
3. PLL Settings Information	8
4. Compliance Summary	10
5. Frequency Accuracy	11
5.1 Option 1	11
5.2 Option 2	11
5.3 Enhanced Option	11
6. Transient Tests with Hitless Switching Enabled	11
6.1 Phase Transient.....	11
6.1.1. Phase Transient – G.8262 EEC Option 1, 1.2Hz.....	12
6.1.2. Phase Transient – G.8262 EEC Option 1, 10Hz.....	17
6.1.3. Phase Transient – G.8262 EEC Option 2, 0.1Hz.....	22
6.1.4. Phase Transient – G.8262.1 eEEEC, 3Hz	26
6.2 Phase Discontinuity	31
6.2.1. Phase Discontinuity – G.8262 EEC Option 1, 1.2Hz	31
6.2.2. Phase Discontinuity – G.8262 EEC Option 1, 10Hz	36
6.2.3. Phase Discontinuity – G.8262 EEC Option 2, 0.1Hz	41
6.2.4. Phase Discontinuity – G.8262.1 eEEEC, 3Hz.....	45
6.3 Short-term Phase Transient Response	50
6.3.1. Short-term Phase Transient Response – G.8262 EEC Option 1, 1.2Hz	50
6.3.2. Short-term Phase Transient Response – G.8262 EEC Option 1, 10Hz	55
6.3.3. Short-term Phase Transient Response – G.8262 EEC Option 2, 0.1Hz	60
6.3.4. Short-term Phase Transient Response – G.8262.1 eEEEC, 3Hz.....	64
7. Transient Tests with Hitless Switching Disabled	69
7.1 Phase Transient.....	69
7.1.1. Phase Transient – G.8262 EEC Option 1, 1.2Hz.....	69
7.1.2. Phase Transient – G.8262 EEC Option 1, 10Hz.....	74
7.1.3. Phase Transient – G.8262 EEC Option 2, 0.1Hz.....	79
7.1.4. Phase Transient – G.8262.1 eEEEC, 3Hz	83
7.2 Phase Discontinuity	88
7.2.1. Phase Discontinuity – G.8262 EEC Option 1, 1.2Hz	88
7.2.2. Phase Discontinuity – G.8262 EEC Option 1, 10Hz	93

7.2.3.	Phase Discontinuity – G.8262 EEC Option 2, 0.1Hz	98
7.2.4.	Phase Discontinuity – G.8262.1 eEEC, 3Hz.....	102
7.3	Short-term Phase Transient Response	107
7.3.1.	Short-term Phase Transient Response – G.8262 EEC Option 1, 1.2Hz	107
7.3.2.	Short-term Phase Transient Response – G.8262 EEC Option 1, 10Hz	112
7.3.3.	Short-term Phase Transient Response – G.8262 EEC Option 2, 0.1Hz	117
7.3.4.	Short-term Phase Transient Response – G.8262.1 eEEC, 3Hz.....	121
8.	Wander Generation.....	126
8.1	Wander Generation – G.8262 EEC Option 1, 1.2Hz.....	126
8.2	Wander Generation – G.8262 EEC Option 1, 10Hz.....	130
8.3	Wander Generation – G.8262 EEC Option 2, 0.1Hz.....	134
8.4	Wander Generation – G.8262.1 eEEC, 3Hz	138
9.	Holdover	142
9.1	Holdover – G.8262 EEC Option 1, 1.2Hz.....	142
9.2	Holdover – G.8262 EEC Option 1, 10Hz.....	147
9.3	Holdover – G.8262 EEC Option 2, 0.1Hz.....	152
9.4	Holdover – G.8262.1 eEEC, 3Hz.....	157
10.	Wander Transfer	162
10.1	Wander Transfer – G.8262 EEC Option 1, 1.2Hz	162
10.1.1.	Wander Transfer Gain Peaking for Standard G.8262 EEC Option 1, 1.2Hz	163
10.2	Wander Transfer – G.8262 EEC Option 1, 10Hz	164
10.2.1.	Wander Transfer Gain Peaking for Standard G.8262 EEC Option 1, 10Hz	165
10.3	Wander Transfer – G.8262 EEC Option 2, 0.1Hz	166
10.3.1.	Wander Transfer Gain Peaking for Standard G.8262 EEC Option 2, 0.1Hz	167
10.4	Wander Transfer – G.8262.1 eEEC, 3Hz.....	168
10.4.1.	Wander Transfer Gain Peaking for Standard G.8262.1 eEEC, 3Hz.....	169
11.	Phase Noise and RMS Jitter	170
11.1	Phase Noise and RMS Jitter: ITU-T G.8262 EEC Option 1, 1.2Hz Bandwidth, 54MHz XO, 12.8MHz TXCO	171
11.2	Phase Noise and RMS Jitter: ITU-T G.8262 EEC Option 1, 10Hz Bandwidth, 54MHz XO, 12.8MHz TXCO	171
11.3	Phase Noise and RMS Jitter: ITU-T G.8262 EEC Option 2, 0.1Hz Bandwidth, 54MHz XO, 12.8MHz TXCO	172
11.4	Phase Noise and RMS Jitter: ITU-T G.8262.1 eEEC, 3Hz Bandwidth, 54MHz XO, 12.8MHz TXCO.....	172
12.	Revision History	173

Figures

Figure 1.	Complete Test Setup.....	7
Figure 2.	Combo Bus Window in RICBox.....	10
Figure 3.	Phase Transient – G.8262 EEC Option 1, 1.2Hz – TIE (no mask)	12
Figure 4.	Phase Transient – G.8262 EEC Option 1, 1.2Hz – TIE	13
Figure 5.	Phase Transient – G.8262 EEC Option 1, 1.2Hz – MTIE	14
Figure 6.	Phase Transient – G.8262 EEC Option 1, 1.2Hz – FFO.....	15

Figure 7. Phase Transient – G.8262 EEC Option 1, 1.2Hz – TDEV	16
Figure 8. Phase Transient – G.8262 EEC Option 1, 10Hz – TIE (no mask)	17
Figure 9. Phase Transient – G.8262 EEC Option 1, 10Hz – TIE	18
Figure 10. Phase Transient – G.8262 EEC Option 1, 10Hz – MTIE	19
Figure 11. Phase Transient – G.8262 EEC Option 1, 10Hz – FFO.....	20
Figure 12. Phase Transient – G.8262 EEC Option 1, 10Hz – TDEV	21
Figure 13. Phase Transient – G.8262 EEC Option 2, 0.1Hz – TIE	22
Figure 14. Phase Transient – G.8262 EEC Option 2, 0.1Hz – MTIE	23
Figure 15. Phase Transient – G.8262 EEC Option 2, 0.1Hz – FFO.....	24
Figure 16. Phase Transient – G.8262 EEC Option 2, 0.1Hz – TDEV	25
Figure 17. Phase Transient – G.8262.1 eEEEC, 3Hz – TIE (no mask).....	26
Figure 18. Phase Transient – G.8262.1 eEEEC, 3Hz – TIE.....	27
Figure 19. Phase Transient – G.8262.1 eEEEC, 3Hz – MTIE.....	28
Figure 20. Phase Transient – G.8262.1 eEEEC, 3Hz – FFO	29
Figure 21. Phase Transient – G.8262.1 eEEEC, 3Hz – TDEV.....	30
Figure 22. Phase Discontinuity – G.8262 EEC Option 1, 1.2Hz – TIE (no mask).....	31
Figure 23. Phase Discontinuity – G.8262 EEC Option 1, 1.2Hz – TIE.....	32
Figure 24. Phase Discontinuity – G.8262 EEC Option 1, 1.2Hz – MTIE.....	33
Figure 25. Phase Discontinuity – G.8262 EEC Option 1, 1.2Hz – FFO	34
Figure 26. Phase Discontinuity – G.8262 EEC Option 1, 1.2Hz – TDEV.....	35
Figure 27. Phase Discontinuity – G.8262 EEC Option 1, 10Hz – TIE (no mask).....	36
Figure 28. Phase Discontinuity – G.8262 EEC Option 1, 10Hz – TIE.....	37
Figure 29. Phase Discontinuity – G.8262 EEC Option 1, 10Hz – MTIE.....	38
Figure 30. Phase Discontinuity – G.8262 EEC Option 1, 10Hz – FFO	39
Figure 31. Phase Discontinuity – G.8262 EEC Option 1, 10Hz – TDEV.....	40
Figure 32. Phase Discontinuity – G.8262 EEC Option 2, 0.1Hz – TIE.....	41
Figure 33. Phase Discontinuity – G.8262 EEC Option 2, 0.1Hz – MTIE.....	42
Figure 34. Phase Discontinuity – G.8262 EEC Option 2, 0.1Hz – FFO	43
Figure 35. Phase Discontinuity – G.8262 EEC Option 2, 0.1Hz – TDEV.....	44
Figure 36. Phase Discontinuity – G.8262.1 eEEEC, 3Hz – TIE (no mask)	45
Figure 37. Phase Discontinuity – G.8262.1 eEEEC, 3Hz – TIE	46
Figure 38. Phase Discontinuity – G.8262.1 eEEEC, 3Hz – MTIE	47
Figure 39. Phase Discontinuity – G.8262.1 eEEEC, 3Hz – FFO.....	48
Figure 40. Phase Discontinuity – G.8262.1 eEEEC, 3Hz – TDEV	49
Figure 41. Short-term Phase Transient Response – G.8262 EEC Option 1, 1.2Hz – TIE (no mask).....	50
Figure 42. Short-term Phase Transient Response – G.8262 EEC Option 1, 1.2Hz – TIE.....	51
Figure 43. Short-term Phase Transient Response – G.8262 EEC Option 1, 1.2Hz – MTIE.....	52
Figure 44. Short-term Phase Transient Response – G.8262 EEC Option 1, 1.2Hz – FFO	53
Figure 45. Short-term Phase Transient Response – G.8262 EEC Option 1, 1.2Hz – TDEV.....	54
Figure 46. Short-term Phase Transient Response – G.8262 EEC Option 1, 10Hz – TIE (no mask).....	55
Figure 47. Short-term Phase Transient Response – G.8262 EEC Option 1, 10Hz – TIE.....	56
Figure 48. Short-term Phase Transient Response – G.8262 EEC Option 1, 10Hz – MTIE.....	57
Figure 49. Short-term Phase Transient Response – G.8262 EEC Option 1, 10Hz – FFO	58
Figure 50. Short-term Phase Transient Response – G.8262 EEC Option 1, 10Hz – TDEV.....	59
Figure 51. Short-term Phase Transient Response – G.8262 EEC Option 2, 0.1Hz – TIE.....	60
Figure 52. Short-term Phase Transient Response – G.8262 EEC Option 2, 0.1Hz – MTIE.....	61

Figure 53. Short-term Phase Transient Response – G.8262 EEC Option 2, 0.1Hz – FFO	62
Figure 54. Short-term Phase Transient Response – G.8262 EEC Option 2, 0.1Hz – TDEV.....	63
Figure 55. Short-term Phase Transient Response – G.8262.1 eEEEC, 3Hz – TIE (no mask)	64
Figure 56. Short-term Phase Transient Response – G.8262.1 eEEEC, 3Hz – TIE	65
Figure 57. Short-term Phase Transient Response – G.8262.1 eEEEC, 3Hz – MTIE	66
Figure 58. Short-term Phase Transient Response – G.8262.1 eEEEC, 3Hz – FFO.....	67
Figure 59. Short-term Phase Transient Response – G.8262.1 eEEEC, 3Hz – TDEV	68
Figure 60. Phase Transient – G.8262 EEC Option 1, 1.2Hz – TIE (no mask).....	69
Figure 61. Phase Transient – G.8262 EEC Option 1, 1.2Hz – TIE	70
Figure 62. Phase Transient – G.8262 EEC Option 1, 1.2Hz – MTIE	71
Figure 63. Phase Transient – G.8262 EEC Option 1, 1.2Hz – FFO.....	72
Figure 64. Phase Transient – G.8262 EEC Option 1, 1.2Hz – TDEV	73
Figure 65. Phase Transient – G.8262 EEC Option 1, 10Hz – TIE (no mask).....	74
Figure 66. Phase Transient – G.8262 EEC Option 1, 10Hz – TIE	75
Figure 67. Phase Transient – G.8262 EEC Option 1, 10Hz – MTIE	76
Figure 68. Phase Transient – G.8262 EEC Option 1, 10Hz – FFO.....	77
Figure 69. Phase Transient – G.8262 EEC Option 1, 10Hz – TDEV	78
Figure 70. Phase Transient – G.8262 EEC Option 2, 0.1Hz – TIE	79
Figure 71. Phase Transient – G.8262 EEC Option 2, 0.1Hz – MTIE	80
Figure 72. Phase Transient – G.8262 EEC Option 2, 0.1Hz – FFO.....	81
Figure 73. Phase Transient – G.8262 EEC Option 2, 0.1Hz – TDEV	82
Figure 74. Phase Transient – G.8262.1 eEEEC, 3Hz – TIE (no mask).....	83
Figure 75. Phase Transient – G.8262.1 eEEEC, 3Hz – TIE.....	84
Figure 76. Phase Transient – G.8262.1 eEEEC, 3Hz – MTIE.....	85
Figure 77. Phase Transient – G.8262.1 eEEEC, 3Hz – FFO	86
Figure 78. Phase Transient – G.8262.1 eEEEC, 3Hz – TDEV.....	87
Figure 79. Phase Discontinuity – G.8262 EEC Option 1, 1.2Hz	88
Figure 80. Phase Discontinuity – G.8262 EEC Option 1, 1.2Hz – TIE.....	89
Figure 81. Phase Discontinuity – G.8262 EEC Option 1, 1.2Hz – MTIE.....	90
Figure 82. Phase Discontinuity – G.8262 EEC Option 1, 1.2Hz – FFO	91
Figure 83. Phase Discontinuity – G.8262 EEC Option 1, 1.2Hz – TDEV	92
Figure 84. Phase Discontinuity – G.8262 EEC Option 1, 10Hz – TIE (no mask).....	93
Figure 85. Phase Discontinuity – G.8262 EEC Option 1, 10Hz – TIE.....	94
Figure 86. Phase Discontinuity – G.8262 EEC Option 1, 10Hz – MTIE.....	95
Figure 87. Phase Discontinuity – G.8262 EEC Option 1, 10Hz – FFO	96
Figure 88. Phase Discontinuity – G.8262 EEC Option 1, 10Hz – TDEV.....	97
Figure 89. Phase Discontinuity – G.8262 EEC Option 2, 0.1Hz – TIE.....	98
Figure 90. Phase Discontinuity – G.8262 EEC Option 2, 0.1Hz – MTIE.....	99
Figure 91. Phase Discontinuity – G.8262 EEC Option 2, 0.1Hz – FFO	100
Figure 92. Phase Discontinuity – G.8262 EEC Option 2, 0.1Hz – TDEV.....	101
Figure 93. Phase Discontinuity – G.8262.1 eEEEC, 3Hz – TIE (no mask)	102
Figure 94. Phase Discontinuity – G.8262.1 eEEEC, 3Hz – TIE	103
Figure 95. Phase Discontinuity – G.8262.1 eEEEC, 3Hz – MTIE	104
Figure 96. Phase Discontinuity – G.8262.1 eEEEC, 3Hz – FFO.....	105
Figure 97. Phase Discontinuity – G.8262.1 eEEEC, 3Hz – TDEV	106
Figure 98. Short-term Phase Transient Response – G.8262 EEC Option 1, 1.2Hz – TIE (no mask).....	107

Figure 99. Short-term Phase Transient Response – G.8262 EEC Option 1, 1.2Hz – TIE.....108

Figure 100. Short-term Phase Transient Response – G.8262 EEC Option 1, 1.2Hz – MTIE.....109

Figure 101. Short-term Phase Transient Response – G.8262 EEC Option 1, 1.2Hz – FFO.....110

Figure 102. Short-term Phase Transient Response – G.8262 EEC Option 1, 1.2Hz – TDEV.....111

Figure 103. Short-term Phase Transient Response – G.8262 EEC Option 1, 10Hz – TIE (no mask).....112

Figure 104. Short-term Phase Transient Response – G.8262 EEC Option 1, 10Hz – TIE.....113

Figure 105. Short-term Phase Transient Response – G.8262 EEC Option 1, 10Hz – MTIE.....114

Figure 106. Short-term Phase Transient Response – G.8262 EEC Option 1, 10Hz – FFO.....115

Figure 107. Short-term Phase Transient Response – G.8262 EEC Option 1, 10Hz – TDEV.....116

Figure 108. Short-term Phase Transient Response – G.8262 EEC Option 2, 0.1Hz – TIE.....117

Figure 109. Short-term Phase Transient Response – G.8262 EEC Option 2, 0.1Hz – MTIE.....118

Figure 110. Short-term Phase Transient Response – G.8262 EEC Option 2, 0.1Hz – FFO.....119

Figure 111. Short-term Phase Transient Response – G.8262 EEC Option 2, 0.1Hz – TDEV.....120

Figure 112. Short-term Phase Transient Response – G.8262.1 eEEC, 3Hz – TIE (no mask).....121

Figure 113. Short-term Phase Transient Response – G.8262.1 eEEC, 3Hz – TIE.....122

Figure 114. Short-term Phase Transient Response – G.8262.1 eEEC, 3Hz – MTIE.....123

Figure 115. Short-term Phase Transient Response – G.8262.1 eEEC, 3Hz – FFO.....124

Figure 116. Short-term Phase Transient Response – G.8262.1 eEEC, 3Hz – TDEV.....125

Figure 117. Wander Generation – G.8262 EEC Option 1, 1.2Hz – TIE.....126

Figure 118. Wander Generation – G.8262 EEC Option 1, 1.2Hz – MTIE.....127

Figure 119. Wander Generation – G.8262 EEC Option 1, 1.2Hz – FFO.....128

Figure 120. Wander Generation – G.8262 EEC Option 1, 1.2Hz – TDEV.....129

Figure 121. Wander Generation – G.8262 EEC Option 1, 10Hz – TIE.....130

Figure 122. Wander Generation – G.8262 EEC Option 1, 10Hz – MTIE.....131

Figure 123. Wander Generation – G.8262 EEC Option 1, 10Hz – FFO.....132

Figure 124. Wander Generation – G.8262 EEC Option 1, 10Hz – TDEV.....133

Figure 125. Wander Generation – G.8262 EEC Option 2, 0.1Hz – TIE.....134

Figure 126. Wander Generation – G.8262 EEC Option 2, 0.1Hz – MTIE.....135

Figure 127. Wander Generation – G.8262 EEC Option 2, 0.1Hz – FFO.....136

Figure 128. Wander Generation – G.8262 EEC Option 2, 0.1Hz – TDEV.....137

Figure 129. Wander Generation – G.8262.1 eEEC, 3Hz – TIE.....138

Figure 130. Wander Generation – G.8262.1 eEEC, 3Hz – MTIE.....139

Figure 131. Wander Generation – G.8262.1 eEEC, 3Hz – FFO.....140

Figure 132. Wander Generation – G.8262.1 eEEC, 3Hz – TDEV.....141

Figure 133. Holdover – G.8262 EEC Option 1, 1.2Hz – TIE (no mask).....142

Figure 134. Holdover – G.8262 EEC Option 1, 1.2Hz – TIE.....143

Figure 135. Holdover – G.8262 EEC Option 1, 1.2Hz – MTIE.....144

Figure 136. Holdover – G.8262 EEC Option 1, 1.2Hz – FFO.....145

Figure 137. Holdover – G.8262 EEC Option 1, 1.2Hz – TDEV.....146

Figure 138. Holdover – G.8262 EEC Option 1, 10Hz.....147

Figure 139. Holdover – G.8262 EEC Option 1, 10Hz – TIE.....148

Figure 140. Holdover – G.8262 EEC Option 1, 10Hz – MTI.....149

Figure 141. Holdover – G.8262 EEC Option 1, 10Hz – FFO.....150

Figure 142. Holdover – G.8262 EEC Option 1, 10Hz – TDEV.....151

Figure 143. Holdover – G.8262 EEC Option 2, 0.1Hz – TIE (no mask).....152

Figure 144. Holdover – G.8262 EEC Option 2, 0.1Hz – TIE.....153

Figure 145. Holdover – G.8262 EEC Option 2, 0.1Hz – MTIE154

Figure 146. Holdover – G.8262 EEC Option 2, 0.1Hz – FFO155

Figure 147. Holdover – G.8262 EEC Option 2, 0.1Hz – TDEV156

Figure 148. Holdover – G.8262.1 eEEEC, 3Hz – TIE (no mask).....157

Figure 149. Holdover – G.8262.1 eEEEC, 3Hz – TIE.....158

Figure 150. Holdover – G.8262.1 eEEEC, 3Hz – MTIE.....159

Figure 151. Holdover – G.8262.1 eEEEC, 3Hz – FFO160

Figure 152. Holdover – G.8262.1 eEEEC, 3Hz – TDEV.....161

Figure 153. Wander Transfer – G.8262 EEC Option 1, 1.2Hz – Phase_Gain162

Figure 154. Wander Transfer – G.8262 EEC Option 1, 10Hz – Phase_Gain164

Figure 155. Wander Transfer – G.8262 EEC Option 2, 0.1Hz – Phase_Gain166

Figure 156. Wander Transfer – G.8262.1 eEEEC, 3Hz – Phase_Gain.....168

Figure 157. Phase Noise and RMS Jitter Measurement Setup.....170

Figure 158. Phase Noise and RMS Jitter for ITU-T G.8262 EEC Option 1, 1.2Hz Bandwidth, 156.25MHz Output, Using a 54MHz XO and a 12.8MHz TCXO.....171

Figure 159. Phase Noise and RMS Jitter for ITU-T G.8262 EEC Option 1, 10Hz Bandwidth, 156.25MHz Output, Using a 54MHz XO and a 12.8MHz TCXO.....171

Figure 160. Phase Noise and RMS Jitter for ITU-T G.8262 EEC Option 2, 0.1Hz Bandwidth, 156.25MHz Output, Using a 54MHz XO and a 12.8MHz TCXO.....172

Figure 161. Phase Noise and RMS Jitter for ITU-T G.8262 eEEEC, 3Hz Bandwidth, 156.25MHz Output, Using a 54MHz XO and a 12.8MHz TCXO172

1. Description of Tests and Setup

This report discusses the results for the SyncE compliance testing of Renesas RC38312Ax / RC38x08Ax (FemtoClock3 Wireless/FC3W) PLLs. PLL configurations were tested for conformity to ITU-T G.8262, G.8262.1 standards for wander generation, wander transfer, phase transient tolerance, holdover, phase transient due to input signal interruptions, and phase transient due to synchronization rearrangement operations.

The testing was performed on the RC38312A1 device, but the results also apply to the RC38312A2, RC38x08A1 and RC38x08A2 devices.

The synchronization rearrangement of the network is introduced through automatic reference switching between two clock inputs or through disconnecting the qualified reference clock input. A frequency generator is used to introduce phase transients and wander on the input clocks. An additional frequency counter is used to measure wander and phase transients.

Figure 1 shows a diagram of the test setup.

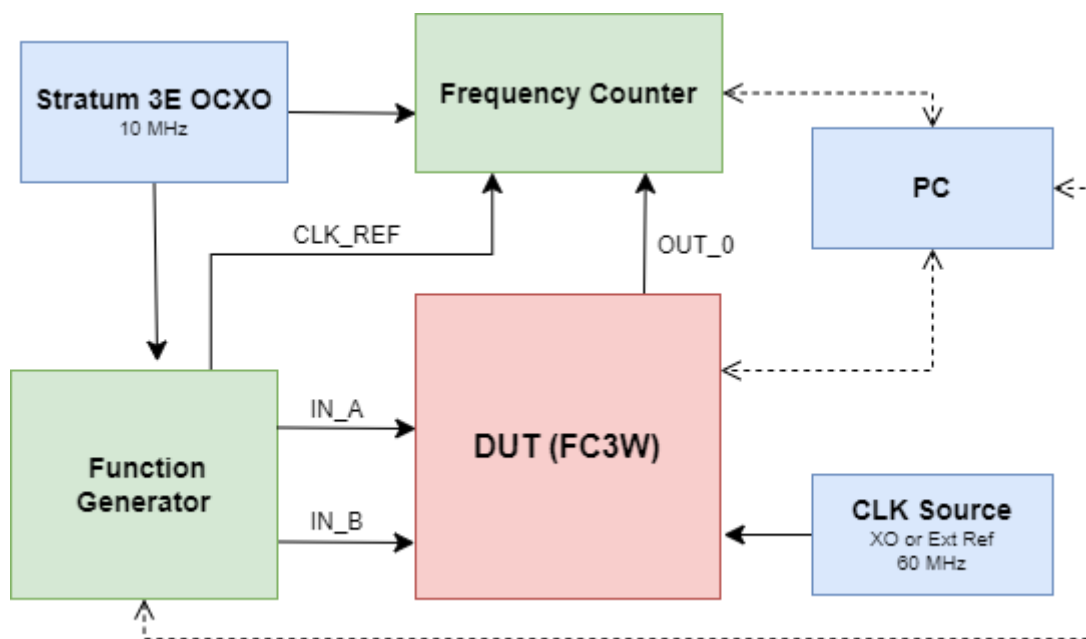

Figure 1. Complete Test Setup

A Stratum 3E OCXO acts as a stable and accurate clock source. Its output serves as the reference clock for the Frequency Counter and Function Generator.

The DUT locks to the reference clock input generated by the function generator. The Renesas FC3W DPLL can lock to virtually any frequency between 1kHz and 1GHz and produce virtually any output frequency from 4kHz to 1GHz. The Renesas FC3W DPLL supports a digital low-pass filter where its bandwidth and phase slope limit is set based on the standard ITU-T G.8262 Opt1/Opt2 or ITU-T G.8262.1 eEEC to test their compliances.

Fractional Frequency Offset (FFO) Maximum Time Interval Error (MTIE) and Time Deviation (TDEV) plots are calculated from the measurements taken from frequency counter. Masks are included on the plots for metrics specified in the standard.

2. Test Equipment Information

Table 1. Test Equipment

Test Equipment Description	Model	Corresponding Block in Figure 1
Frequency Reference	Rakon STP3384LF	Stratum 3E OCXO
ClockMatrix Evaluation Board	ClockMatrix 8A34001E 144BGA EVB	Frequency Counter
ClockMatrix Evaluation Board	ClockMatrix 8A34001E 144BGA EVB	Function Generator
ClockMatrix Evaluation Board	ClockMatrix 8A34001E 144BGA EVB	CLK Source

3. PLL Settings Information

The tables in this section highlight the required PLL settings that are configured for the testing showcased in this document.

In addition to configuring the PLLs, the device combo bus is also configured to provide the correct clock steering to the APLL and FODs. Figure 2 shows the combo bus settings for the configurations tested for this document. The jitter attenuator DPLL (DPLL0) and the System DPLL (DPLL2) must be configured to provide frequency steering to the APLL. This means that the frequency accuracy of the APLL will be a summation of the SyncE reference clock accuracy and the TCXO accuracy. FOD0, FOD1, and FOD2 should receive frequency steering from the System DPLL only. Thus, the frequency accuracy of the FODs will be determined by the frequency accuracy of the TCXO.

Table 2. PLL Settings Based on Compliance Standard Table

Compliance Standard No.	ITU-T G.8262 Option 1	ITU-T G.8262 Option 2	ITU-T G.8262.1 eEEC	Register Name in RICBox ¹
Input Frequency (MHz)	25.00	25.00	25.00	input_freq_clkin1
Output Frequency (MHz)	25.00	25.00	25.00	out0_freq_goal
PLL Bandwidth (Hz)	1.2/10.0	0.1	3	dpll0_normal_bandwidth_goal
Phase Slope Limit (μs/s)	7.500	0.885	7.500	dpll0_phase_slope_limit_goal
Max Phase Lock Error (ns)	250	600	250	dpll0_lock_threshold_goal
Damping Factor	<0.2 dB	<0.2 dB	<0.2 dB	dpll0_normal_gain_peaking_goal

¹ Exact register names depend on the inputs, outputs, and DPLLs used in the configuration.

Table 3. Other PLL Settings used for Compliance Testing

Setting	Value	Register Name in RICBox ²
Holdover History	15s	TOP.DPLL[0].DPLL_HOLDOVER_CNFG.holdover_history
DPLL Operation Mode	JA	operation_mode_dp1l0
Los_mon_enable	True (for both references)	Los_mon_enable_ref1
Freq_mon_enable	True (for both references)	Freq_mon_enable_ref1
Holdover BW	0.1Hz (G.8262.1/G.8262 EEC1), 0.01Hz (G.8262 EEC2)	dp1l0_holdover_bandwidth_goal
Acquire BW	10x normal bandwidth	dp1l0_acquire_bandwidth_goal
Ap1l Goal Frequency	10.2GHz	ap1l_freq_goal
XTAL/XO Input Frequency	60MHz	input_freq_xtal
Hitless Switching	True/False	top.DPLL[0].DPLL_REF_FB_CNFG.dp1l_hitless_en

Table 4. System DPLL PLL Settings

Setting	Value	Register Name in RICBox ³
PLL Bandwidth (Hz)	300 Hz	dp1l2_normal_bandwidth_goal
Phase Slope Limit (μs/s)	256000 ns/s	dp1l2_phase_slope_limit_goal
Max Phase Lock Error (ns)	None	dp1l2_lock_threshold_goal
Damping Factor	None	dp1l2_normal_gain_peaking_goal

Table 5. Combo Bus Settings

Setting	Value	Register Name in RICBox ³
PLL Steering from DPLL0 to AP1L	Enabled	combo_dp1l0_to_ap1l
PLL Steering from DPLL0 to AP1L	Enabled	combo_dp1l2_to_ap1l
PLL Steering from DPLL2 to FOD0	Enabled	combo_dp1l2_to_fod0
PLL Steering from DPLL2 to FOD0	Enabled	combo_dp1l2_to_fod1
PLL Steering from DPLL2 to FOD0	Enabled	combo_dp1l2_to_fod2

² Exact register names depend on the inputs, outputs, and DPLLs used in the configuration.

³ Exact register names depend on the DPLL used in the configuration.

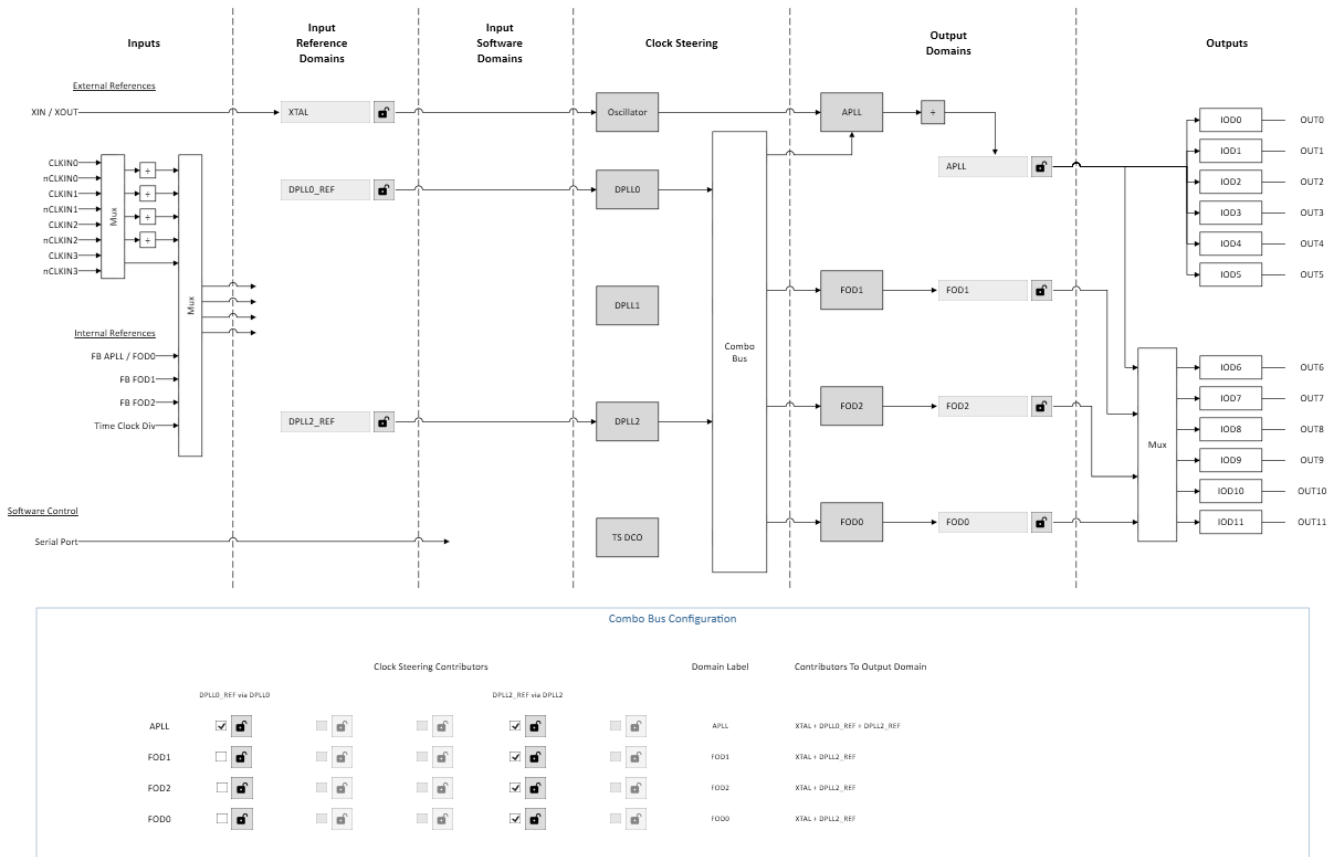

Figure 2. Combo Bus Window in RICBox

4. Compliance Summary

Table 6 summarizes the results of the compliance testing.

Table 6. Compliance Results

Test	ITU-T G.8262 Option 1	ITU-T G.8262 Option 2	ITU-T G.8262.1 eEEC
Phase Transient with Hitless Switching Enabled	Pass	Pass	Pass
Phase Discontinuity with Hitless Switching Enabled	Pass	Pass	Pass
Short Term Phase Transient with Hitless Switching Enabled	Pass	Pass	Pass
Phase Transient with Hitless Switching Disabled	Pass	Pass	Pass
Phase Discontinuity with Hitless Switching Disabled	Pass	Pass	Pass
Short Term Phase Transient with Hitless Switching Disabled	Pass	Pass	Pass
Wander Generation	Pass	Pass	Pass
Wander Transfer	Pass	Pass	Pass

5. Frequency Accuracy

Frequency accuracy at free-run is determined by the system oscillator used. For more information, see application note [AN-807](#).

Note: The DUT only contributes to the initial frequency offset (a1) and transition phase shift (c) on entry into holdover. The drift (b) and frequency offset due to temperature (a2) comes from the local oscillator

5.1 Option 1

Refer to section G.813 Option 1 / G.8262 Option 1 (see Table 8 in [AN-807](#)).

5.2 Option 2

Refer to section GR-1244-CORE and GR-253-CORE Stratum 3 / G.812 Type IV / G.8262 Option 2 (see Table 7 in [AN-807](#)).

5.3 Enhanced Option

The enhanced option can also be used for both Options 1 and 2. Refer to section G.8262.1 Enhanced Synchronous Ethernet/OTN Equipment Clock (see Table 6 in [AN-807](#)).

6. Transient Tests with Hitless Switching Enabled

6.1 Phase Transient

Transient response requirement reflects the system response in situations where the input signal is affected by disturbances or transmission failures, thus resulting in phase transients at the synchronous EEC (Ethernet Equipment Clock) output. Short interruptions, switching between different reference clock signals, loss of reference etc., are categorized as transients, thus resulting in phase transients at the EEC output (see [Figure 1](#) for the equipment configuration).

In this test, the reference clock inputs are provided on IN_A and IN_B from the Frequency Generator. The PLL is locked to the clock signal from IN_A for a period of time before producing a phase transient by turning off IN_A. The DPLL goes into holdover and tries to lock to any other qualified clocks. IN_B is simultaneously available from the Frequency Generator, and the DPLL switches to this clock which is very close in phase alignment to the original clock. The output from the DUT is available on OUT_0 and the phase time error is captured using the Frequency Counter. The results of the given transient are plotted against the applicable standard profiles.

6.1.1. Phase Transient – G.8262 EEC Option 1, 1.2Hz

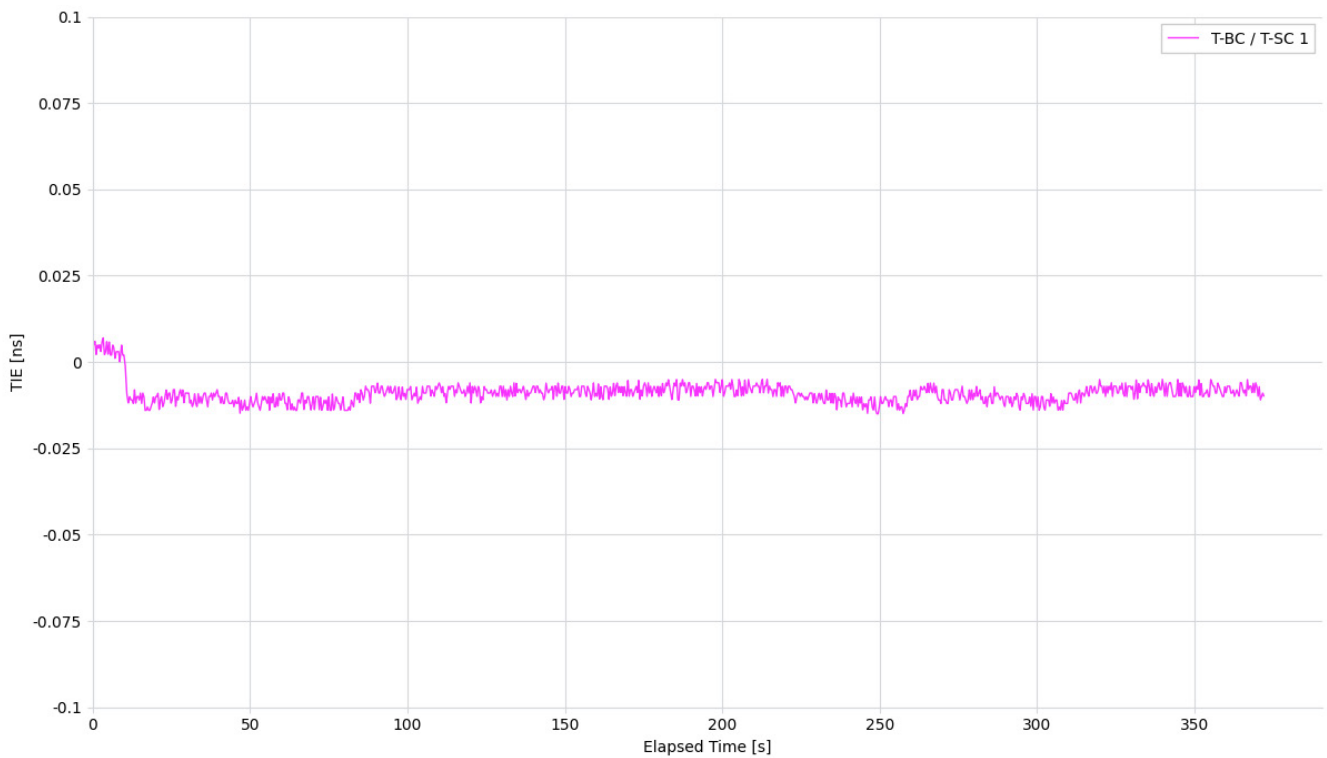

Figure 3. Phase Transient – G.8262 EEC Option 1, 1.2Hz – TIE (no mask)

	T-BC / T-SC 1
Mean [ns]	-0.009
Min [ns]	-0.015
Max [ns]	0.007
Max-Min [ns]	0.022

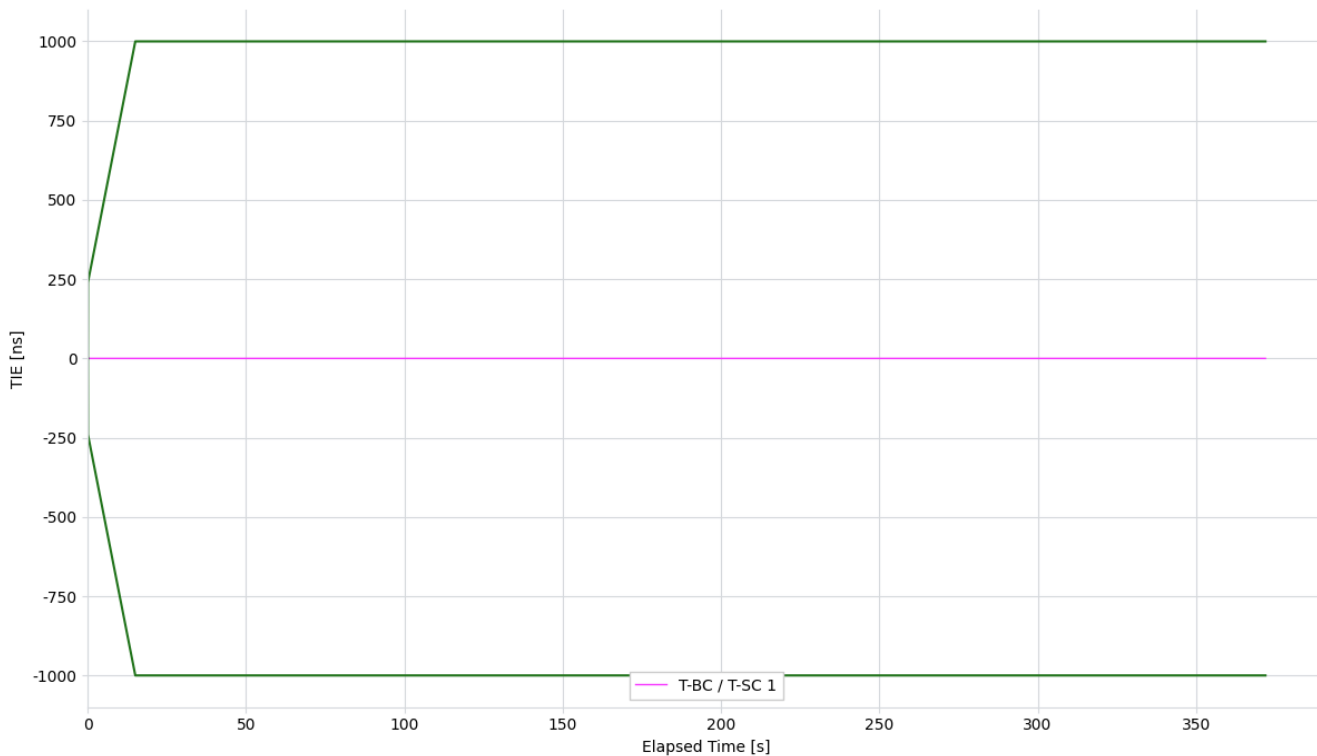

Figure 4. Phase Transient – G.8262 EEC Option 1, 1.2Hz – TIE

	T-BC / T-SC 1
Mean [ns]	-0.009
Min [ns]	-0.015
Max [ns]	0.007
Max-Min [ns]	0.022

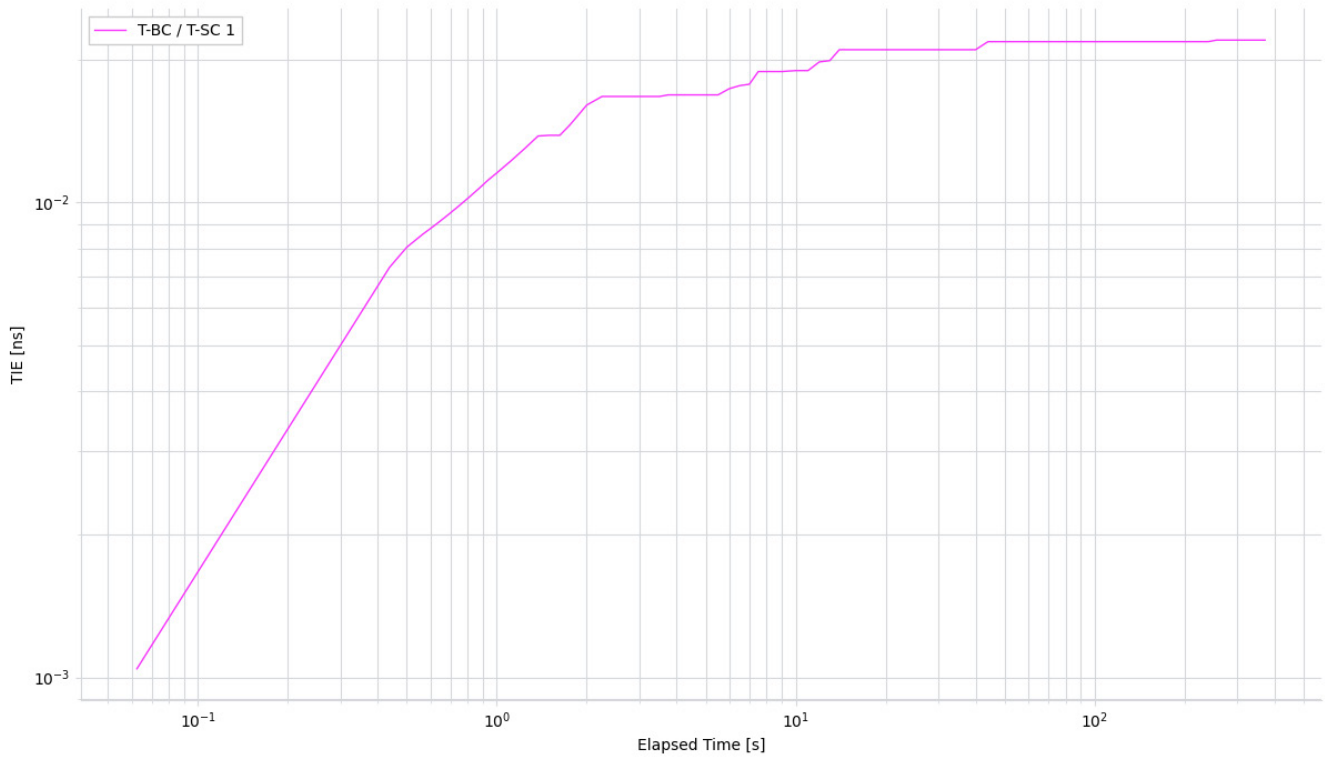

Figure 5. Phase Transient – G.8262 EEC Option 1, 1.2Hz – MTIE

	T-BC / T-SC 1
Min [ns]	0.001
Max [ns]	0.022
Max-Min [ns]	0.021

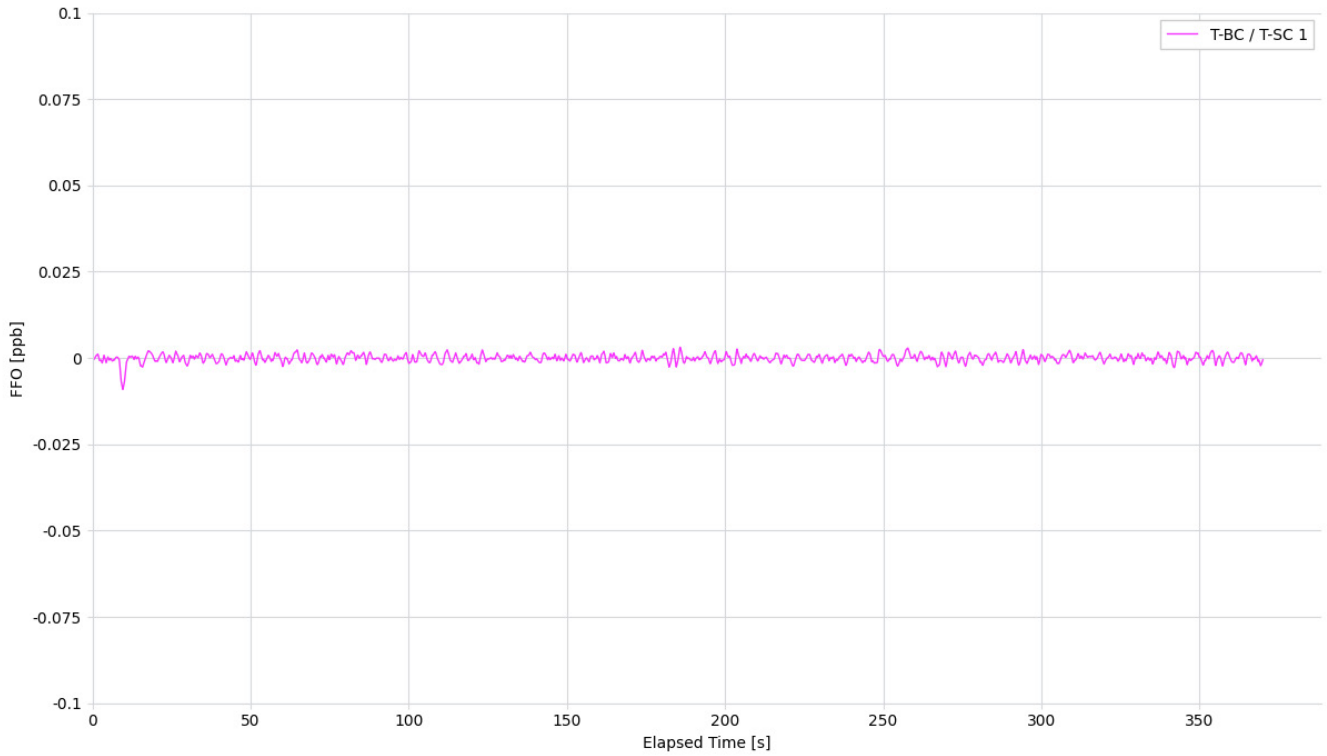

Figure 6. Phase Transient – G.8262 EEC Option 1, 1.2Hz – FFO

	T-BC / T-SC 1
Mean [ppb]	-0.0
Min [ppb]	-0.009
Max [ppb]	0.003
Max-Min [ppb]	0.012

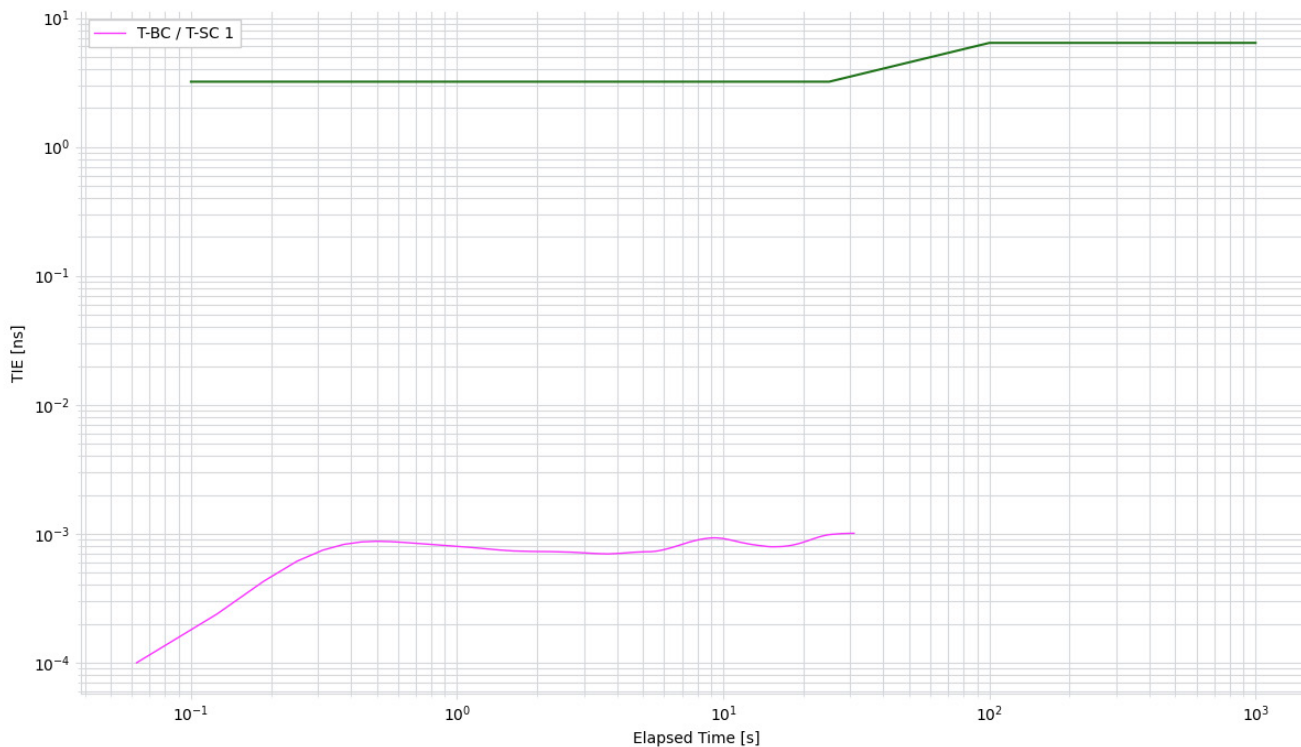

Figure 7. Phase Transient – G.8262 EEC Option 1, 1.2Hz – TDEV

	T-BC / T-SC 1
Min [ns]	0.0
Max [ns]	0.001
Max-Min [ns]	0.001

6.1.2. Phase Transient – G.8262 EEC Option 1, 10Hz

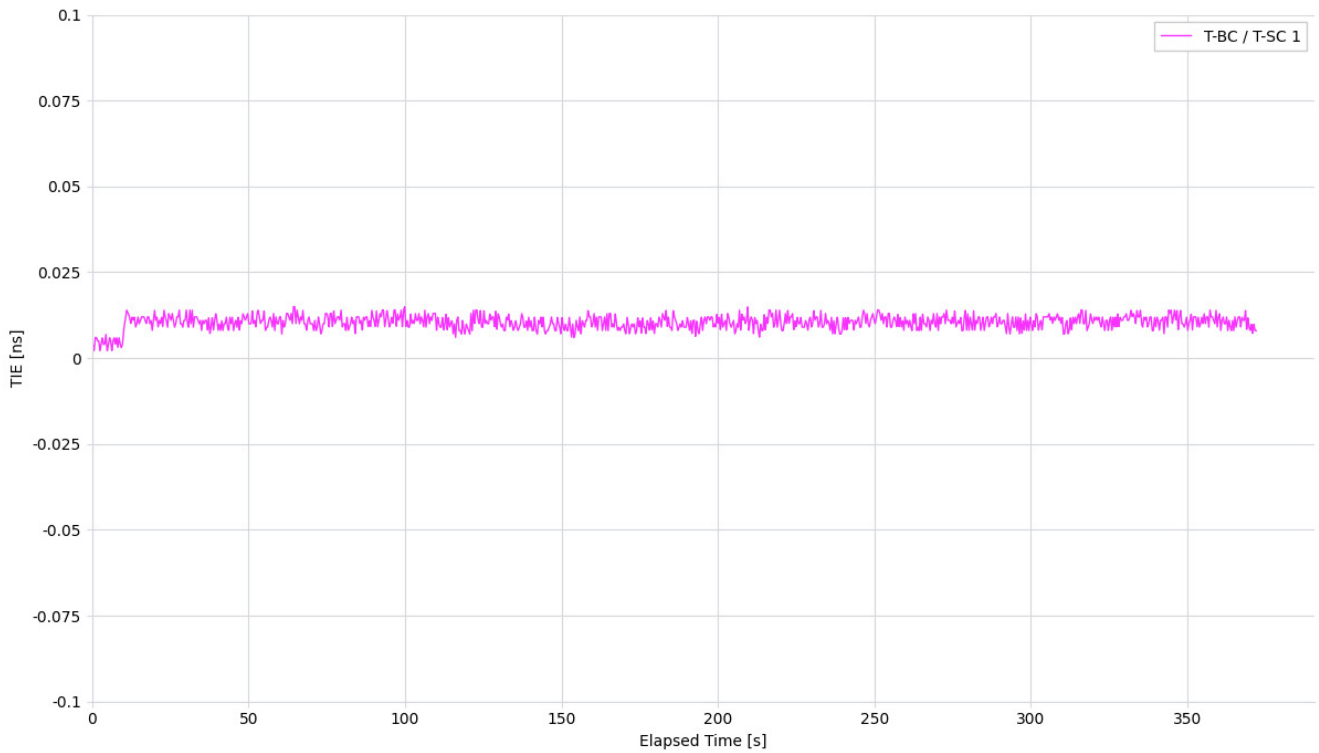

Figure 8. Phase Transient – G.8262 EEC Option 1, 10Hz – TIE (no mask)

	T-BC / T-SC 1
Mean [ns]	0.01
Min [ns]	0.002
Max [ns]	0.015
Max-Min [ns]	0.013

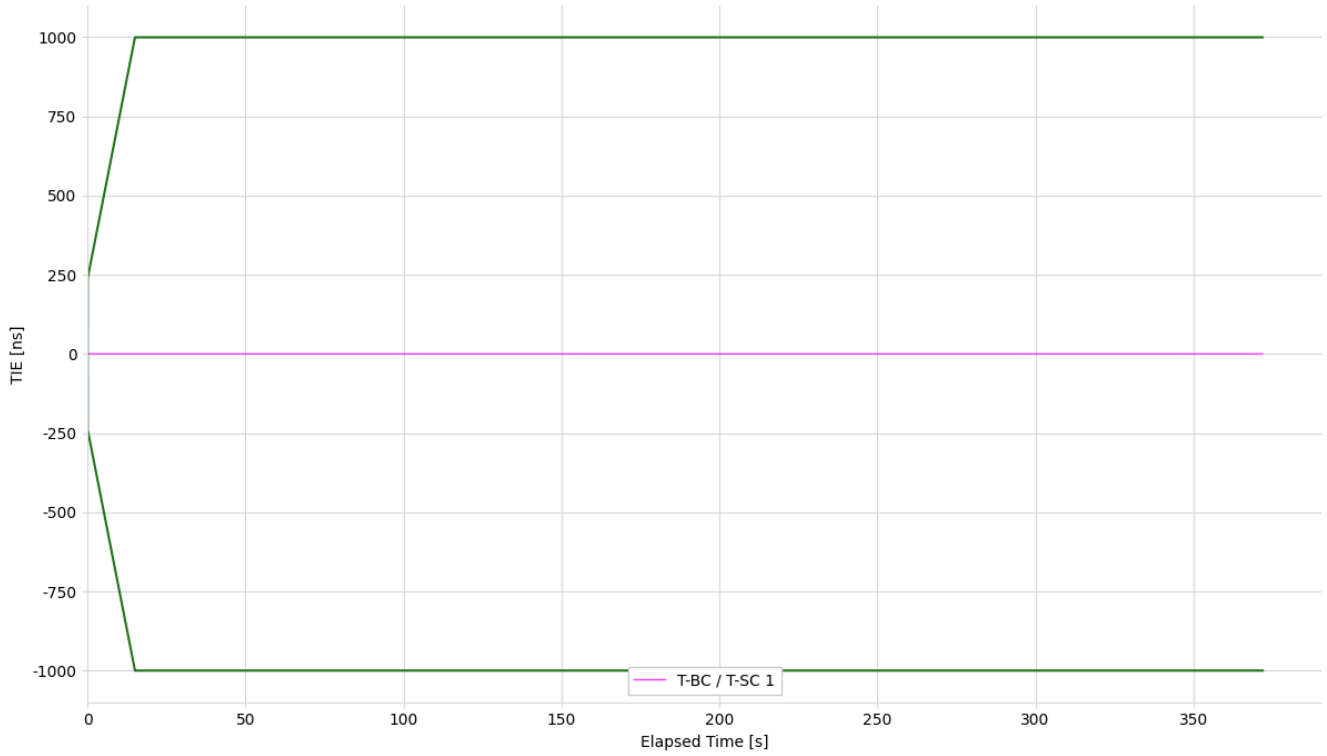

Figure 9. Phase Transient – G.8262 EEC Option 1, 10Hz – TIE

	T-BC / T-SC 1
Mean [ns]	0.01
Min [ns]	0.002
Max [ns]	0.015
Max-Min [ns]	0.013

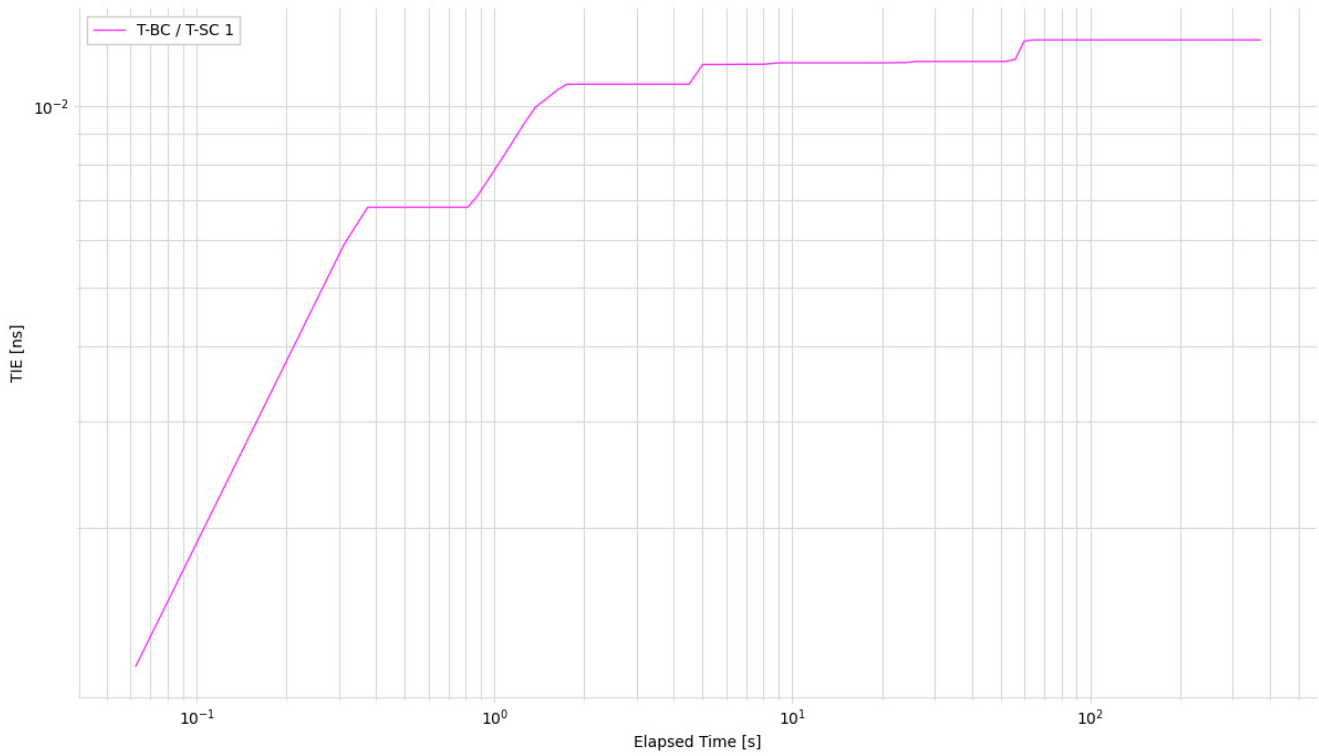

Figure 10. Phase Transient – G.8262 EEC Option 1, 10Hz – MTIE

	T-BC / T-SC 1
Min [ns]	0.001
Max [ns]	0.013
Max-Min [ns]	0.012

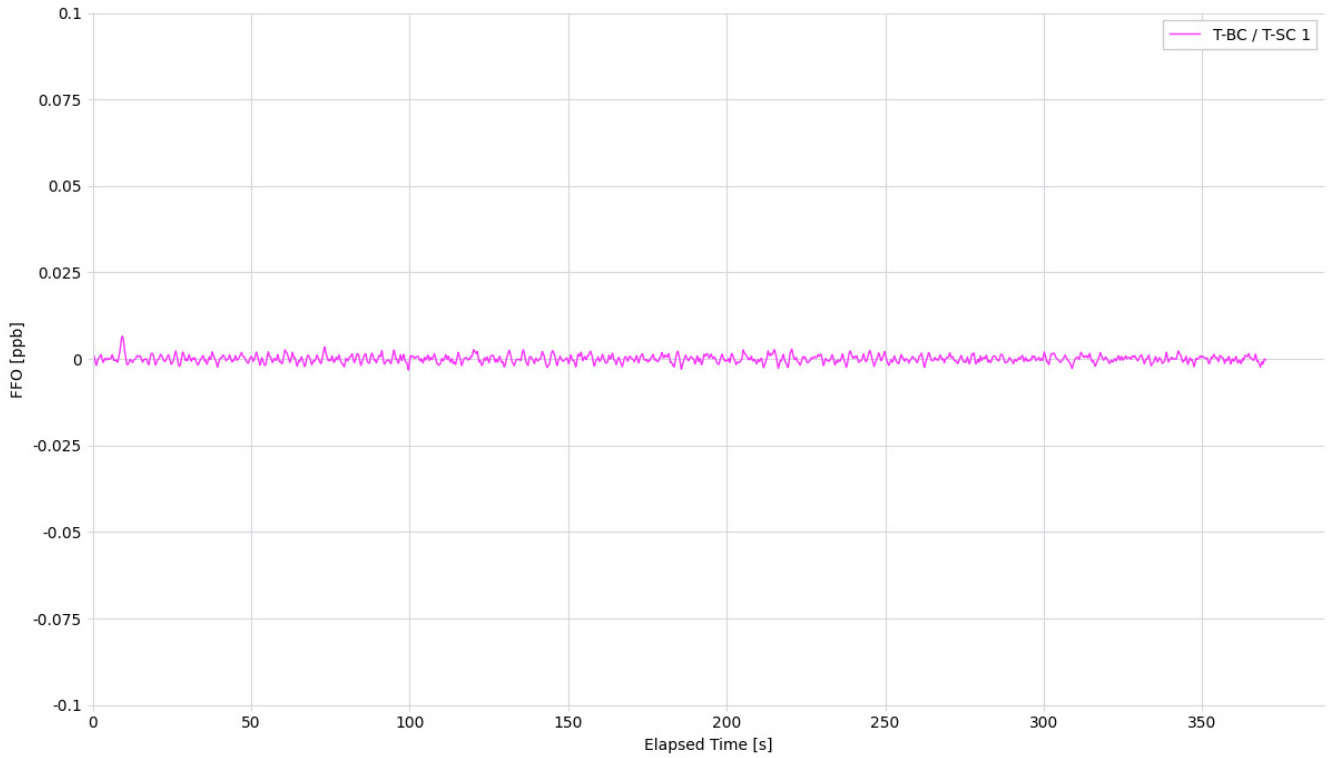

Figure 11. Phase Transient – G.8262 EEC Option 1, 10Hz – FFO

	T-BC / T-SC 1
Mean [ppb]	0.0
Min [ppb]	-0.003
Max [ppb]	0.007
Max-Min [ppb]	0.01

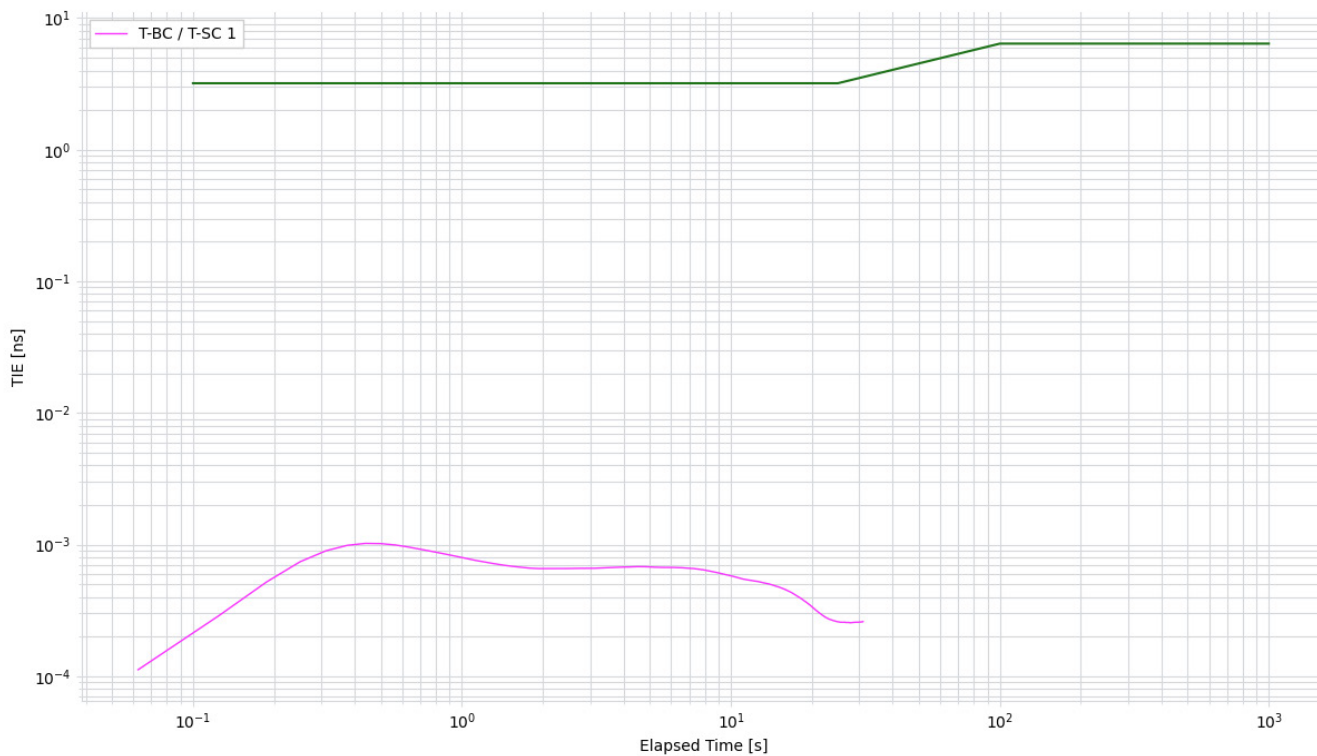

Figure 12. Phase Transient – G.8262 EEC Option 1, 10Hz – TDEV

	T-BC / T-SC 1
Min [ns]	0.0
Max [ns]	0.001
Max-Min [ns]	0.001

6.1.3. Phase Transient – G.8262 EEC Option 2, 0.1Hz

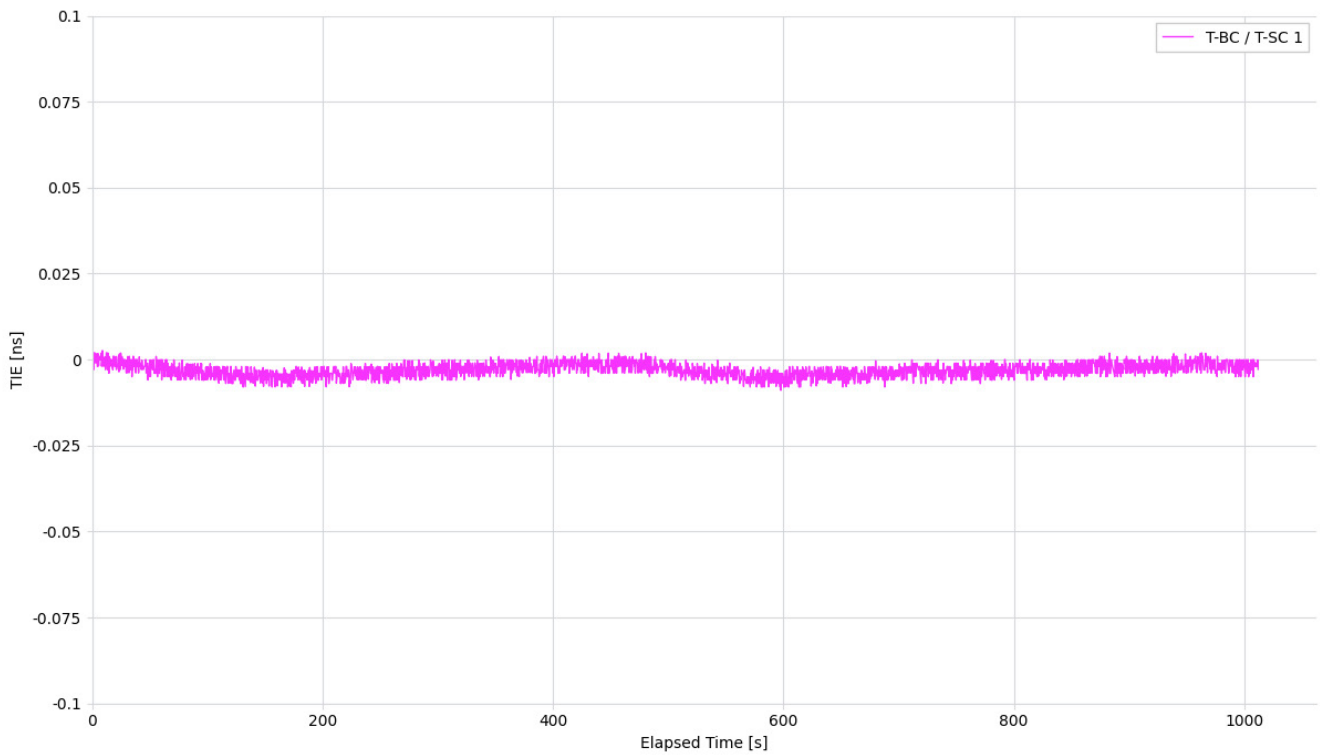

Figure 13. Phase Transient – G.8262 EEC Option 2, 0.1Hz – TIE

	T-BC / T-SC 1
Mean [ns]	-0.003
Min [ns]	-0.009
Max [ns]	0.003
Max-Min [ns]	0.012

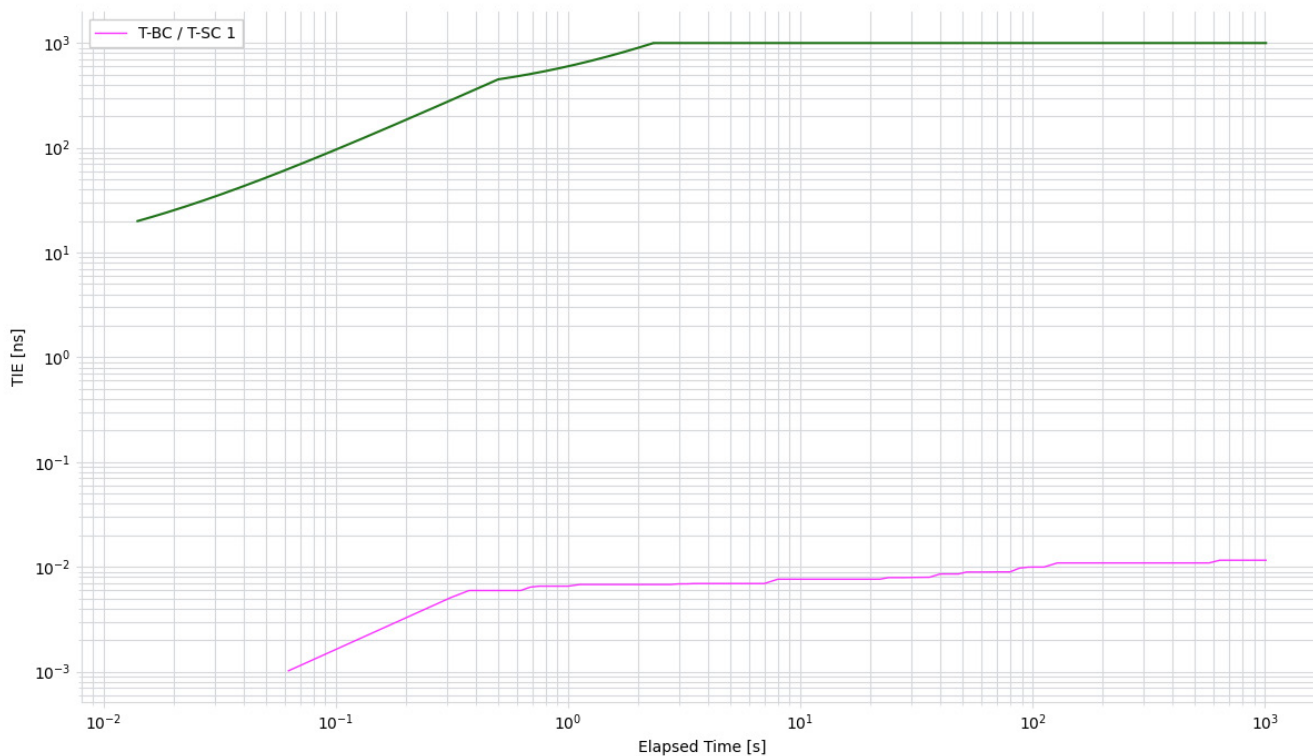

Figure 14. Phase Transient – G.8262 EEC Option 2, 0.1Hz – MTIE

	T-BC / T-SC 1
Min [ns]	0.001
Max [ns]	0.012
Max-Min [ns]	0.011

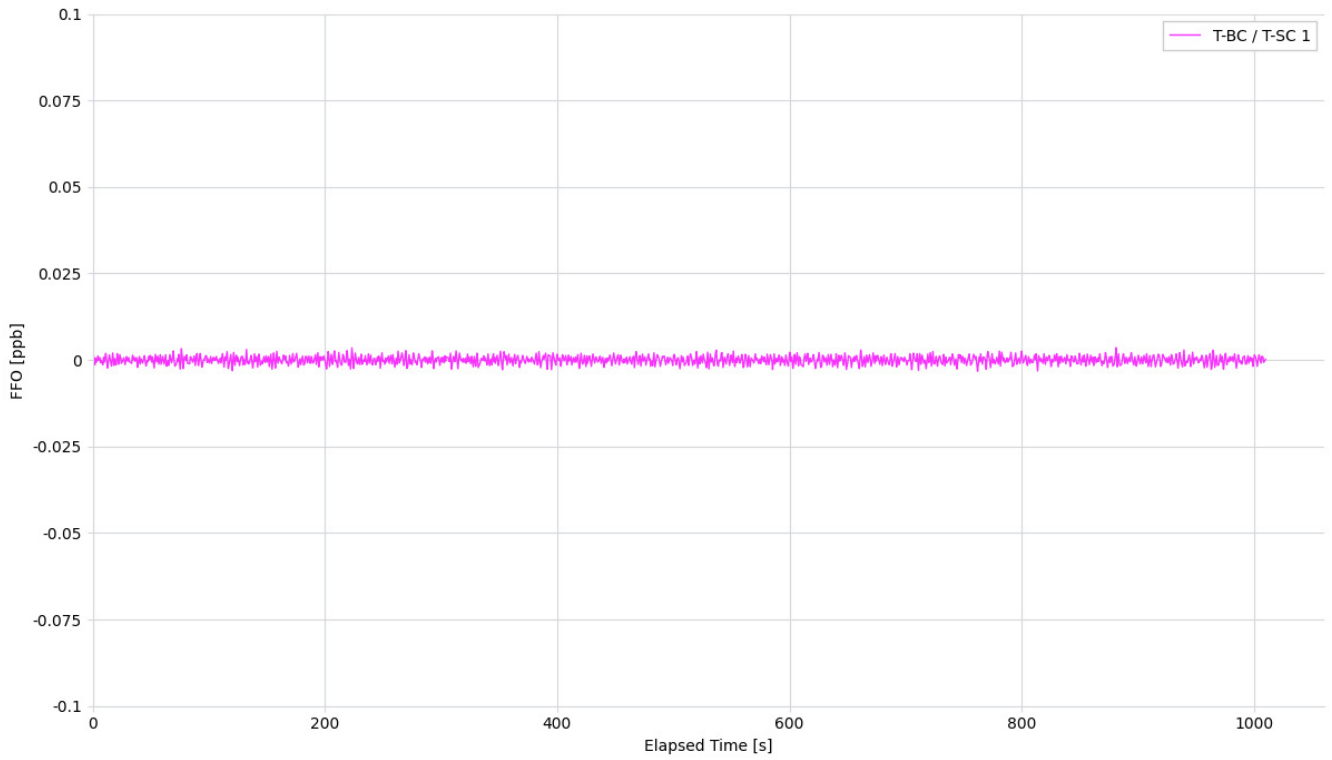

Figure 15. Phase Transient – G.8262 EEC Option 2, 0.1Hz – FFO

	T-BC / T-SC 1
Mean [ppb]	-0.0
Min [ppb]	-0.003
Max [ppb]	0.004
Max-Min [ppb]	0.007

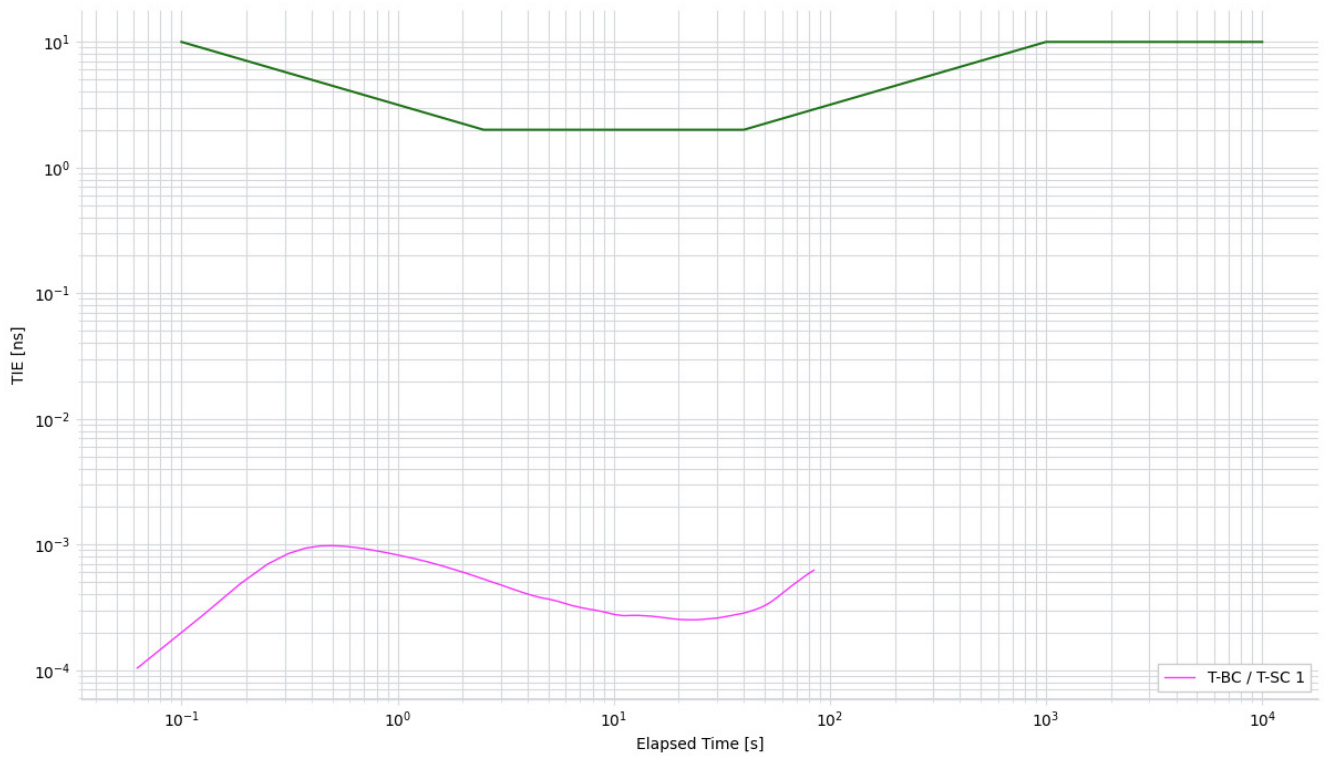

Figure 16. Phase Transient – G.8262 EEC Option 2, 0.1Hz – TDEV

	T-BC / T-SC 1
Min [ns]	0.0
Max [ns]	0.001
Max-Min [ns]	0.001

6.1.4. Phase Transient – G.8262.1 eEEC, 3Hz

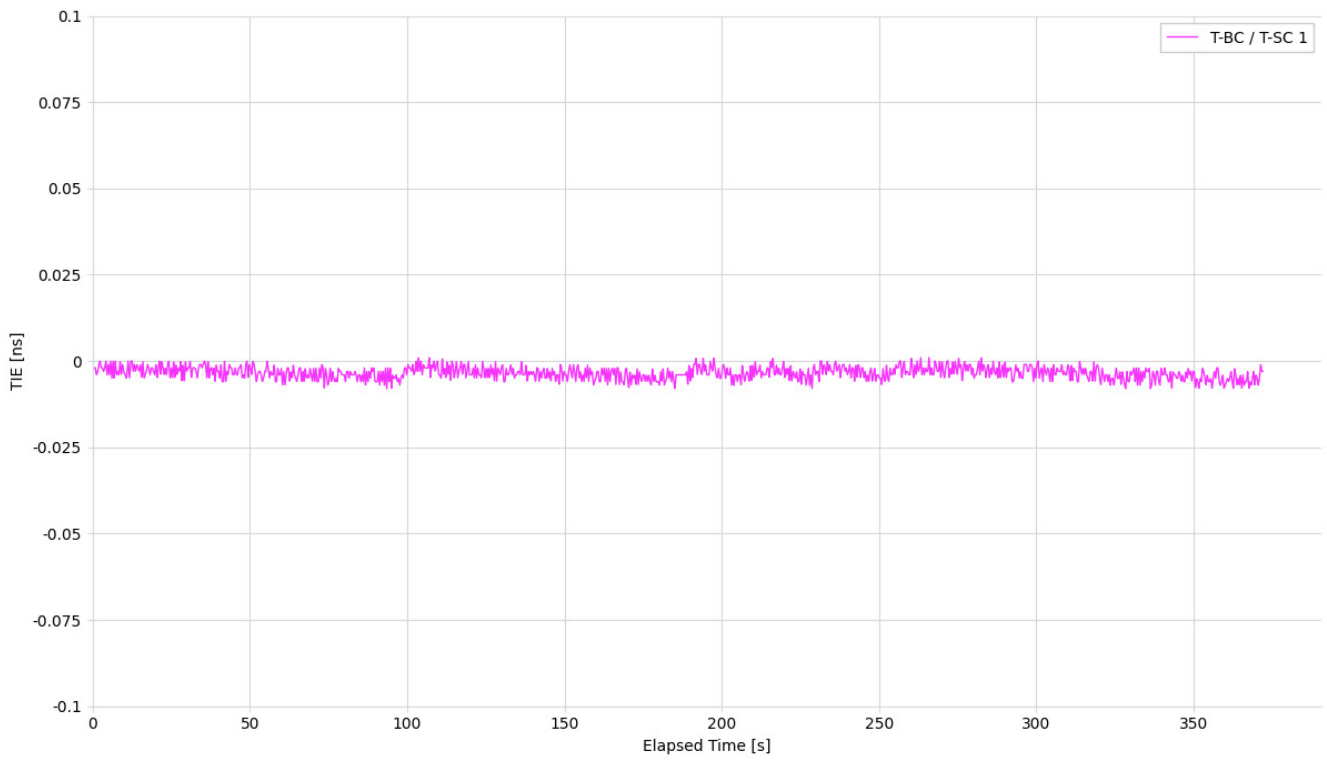

Figure 17. Phase Transient – G.8262.1 eEEC, 3Hz – TIE (no mask)

	T-BC / T-SC 1
Mean [ns]	-0.003
Min [ns]	-0.008
Max [ns]	0.001
Max-Min [ns]	0.009

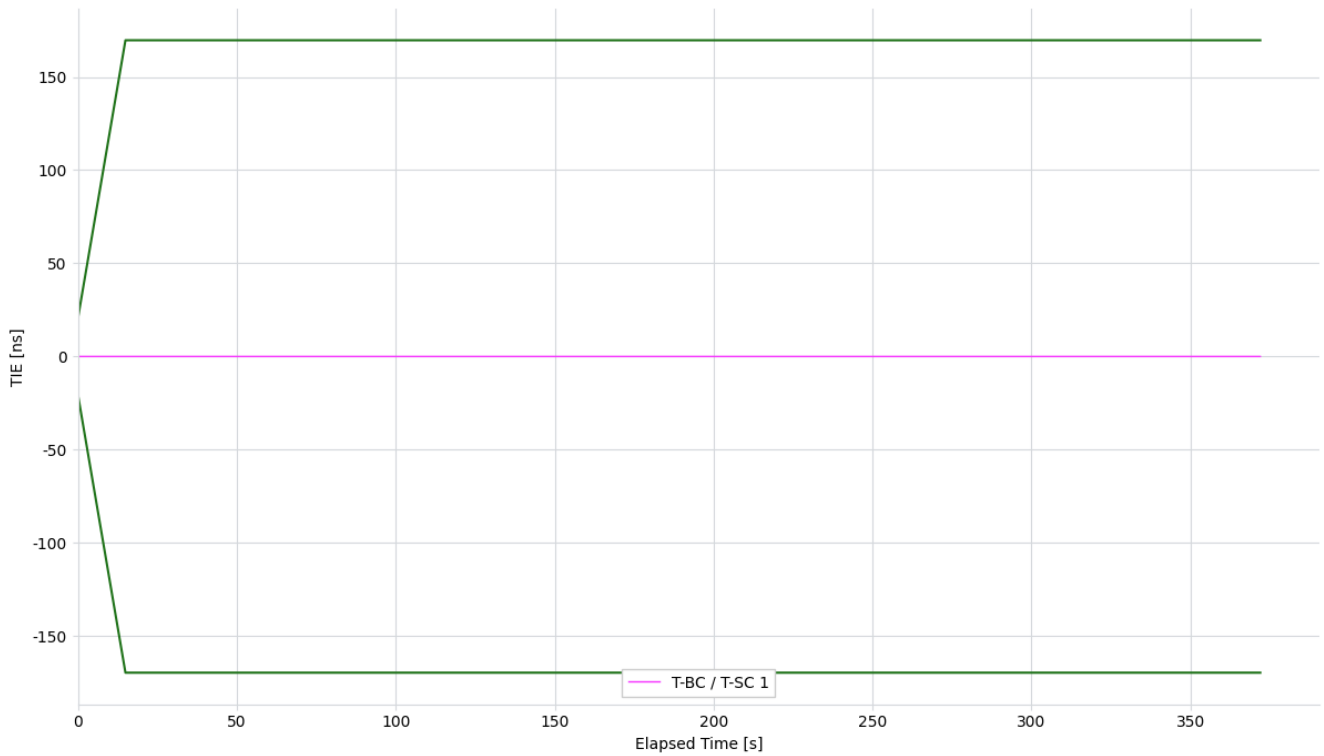

Figure 18. Phase Transient – G.8262.1 eEEC, 3Hz – TIE

	T-BC / T-SC 1
Mean [ns]	-0.003
Min [ns]	-0.008
Max [ns]	0.001
Max-Min [ns]	0.009

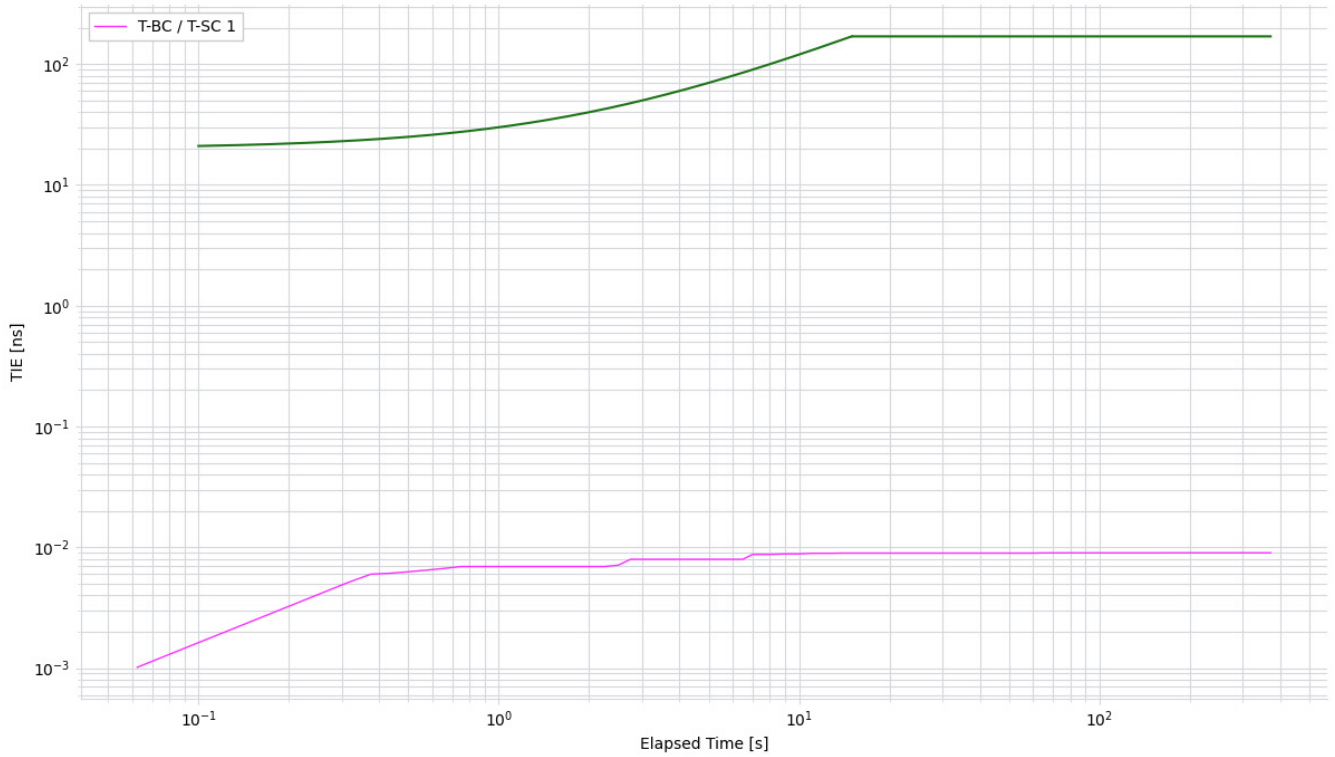

Figure 19. Phase Transient – G.8262.1 eEEC, 3Hz – MTIE

	T-BC / T-SC 1
Min [ns]	0.001
Max [ns]	0.009
Max-Min [ns]	0.008

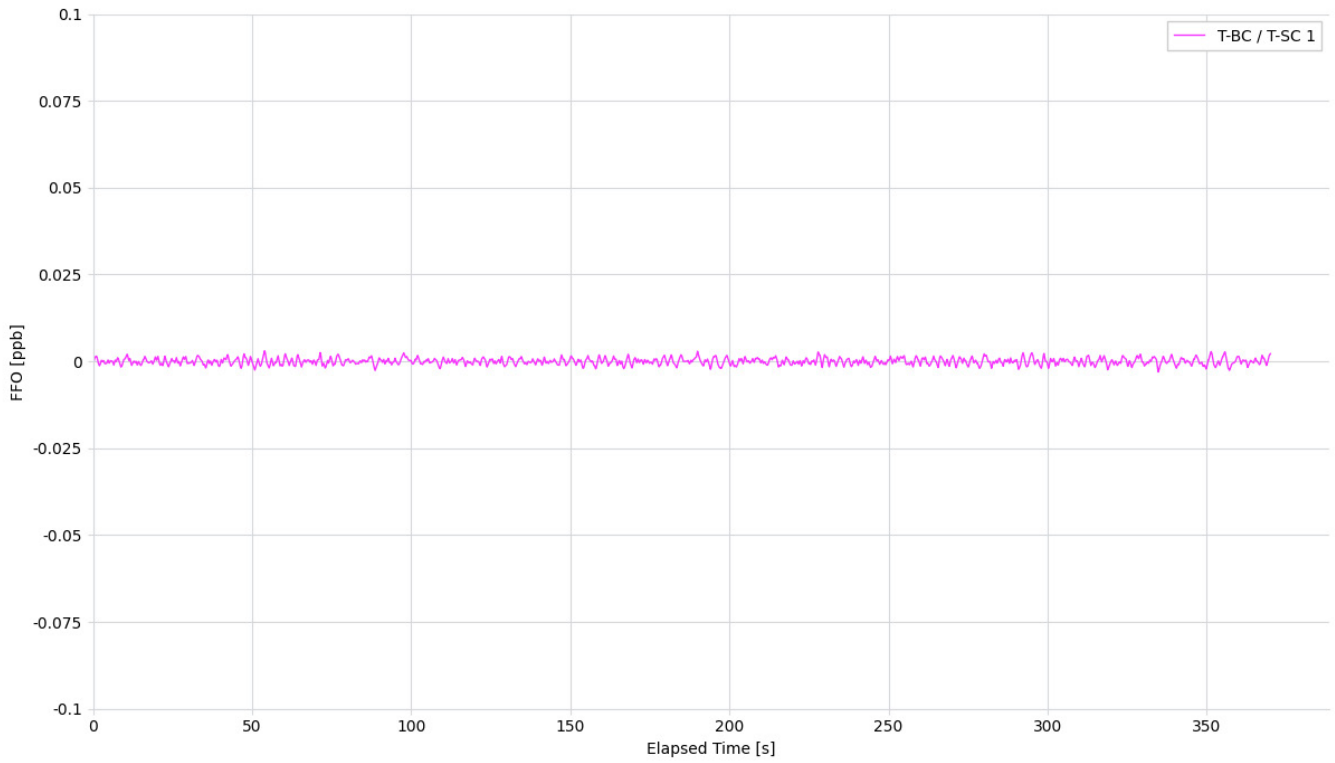

Figure 20. Phase Transient – G.8262.1 eEEC, 3Hz – FFO

	T-BC / T-SC 1
Mean [ppb]	-0.0
Min [ppb]	-0.003
Max [ppb]	0.003
Max-Min [ppb]	0.006

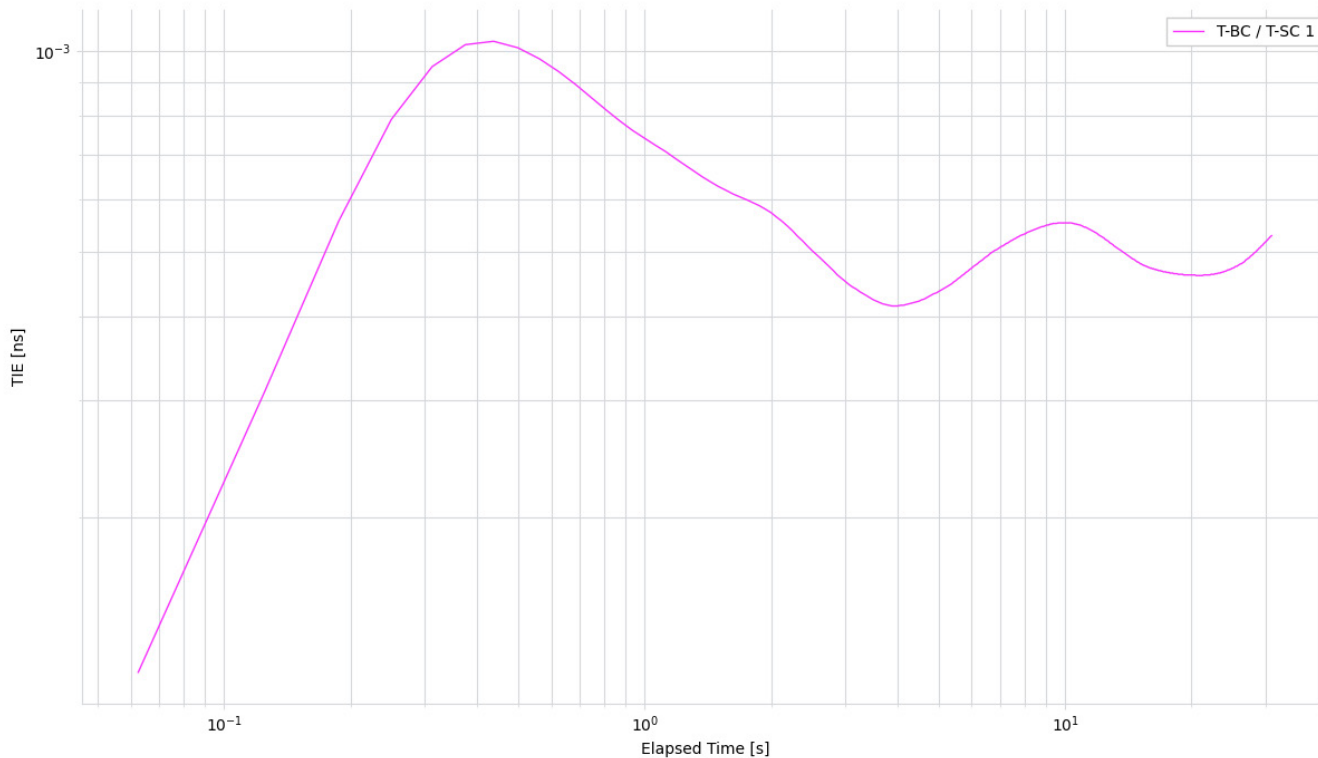

Figure 21. Phase Transient – G.8262.1 eEEC, 3Hz – TDEV

	T-BC / T-SC 1
Min [ns]	0.0
Max [ns]	0.001
Max-Min [ns]	0.001

6.2 Phase Discontinuity

Phase discontinuity requirement reflects the performance of the DUT in cases when the (selected) input reference is lost due to a failure in the reference path and a second reference input signal, traceable to the same reference clock, is available simultaneously, or shortly after the detection of the failure (see Figure 1 for the equipment configuration).

The test was carried out by providing reference clock inputs on IN_A and IN_B from the Frequency Generator which are 180° out of phase from each other. The PLL is locked to the clock signal from IN_A for a given period of time before producing a phase transient by turning off the signal to IN_A from the waveform generator while the signal at IN_B is simultaneously available to the DUT. The DPLL will try to lock to the reference signal on IN_B. The output from the DUT is available on OUT_0 and the phase time error is captured using the Frequency Counter. The results of the given transient are plotted against the applicable standard profiles.

6.2.1. Phase Discontinuity – G.8262 EEC Option 1, 1.2Hz

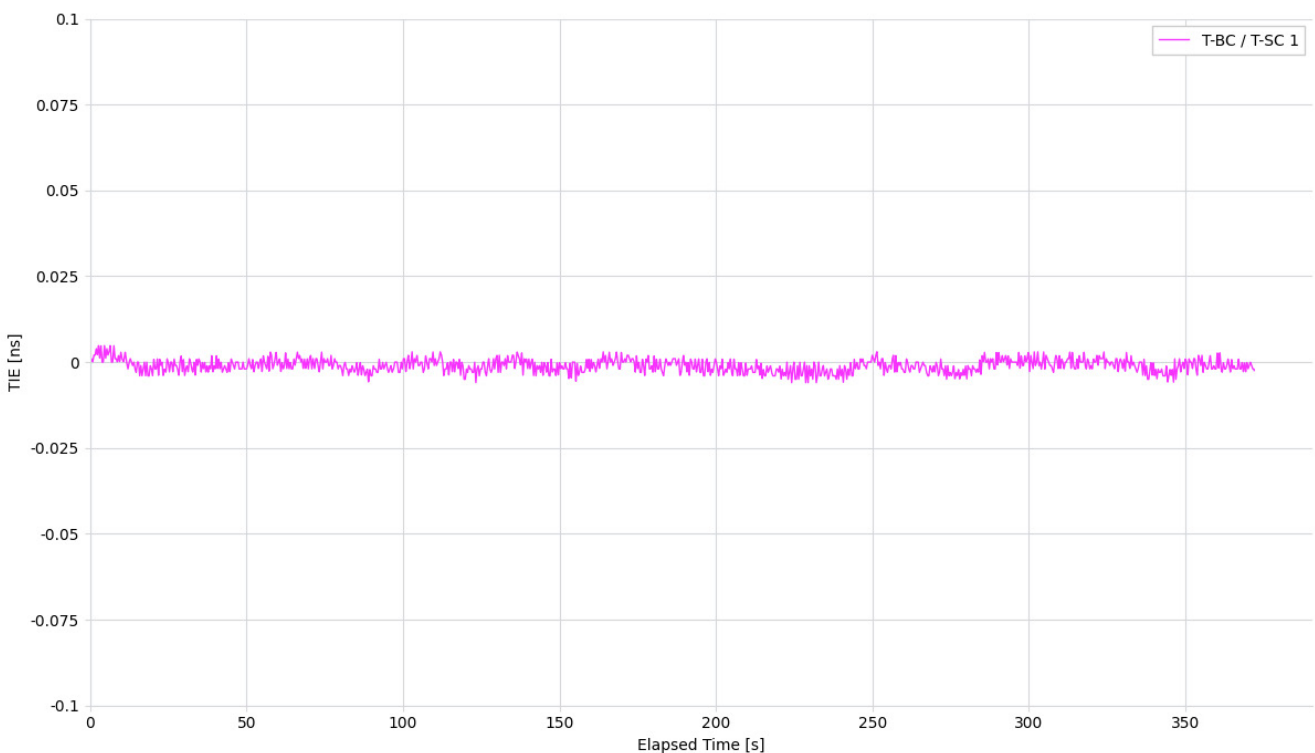

Figure 22. Phase Discontinuity – G.8262 EEC Option 1, 1.2Hz – TIE (no mask)

	T-BC / T-SC 1
Mean [ns]	-0.001
Min [ns]	-0.006
Max [ns]	0.005
Max-Min [ns]	0.011

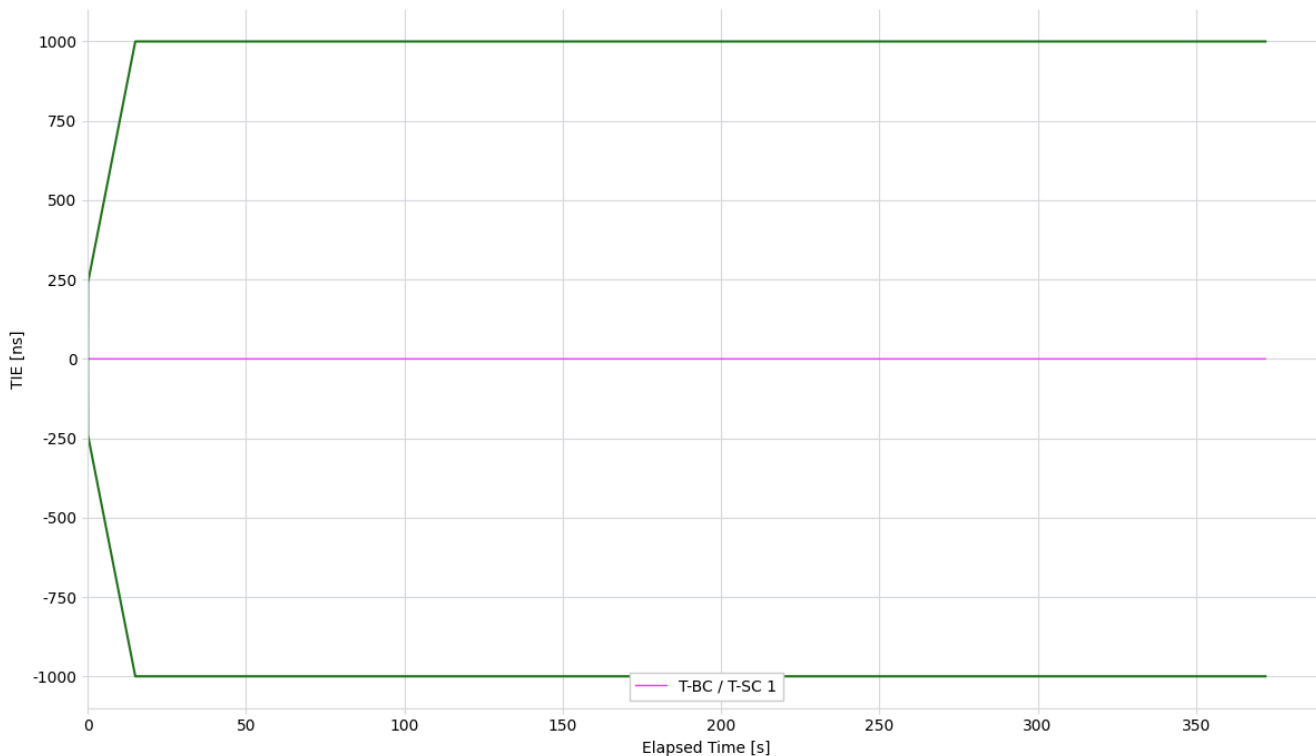

Figure 23. Phase Discontinuity – G.8262 EEC Option 1, 1.2Hz – TIE

	T-BC / T-SC 1
Mean [ns]	-0.001
Min [ns]	-0.006
Max [ns]	0.005
Max-Min [ns]	0.011

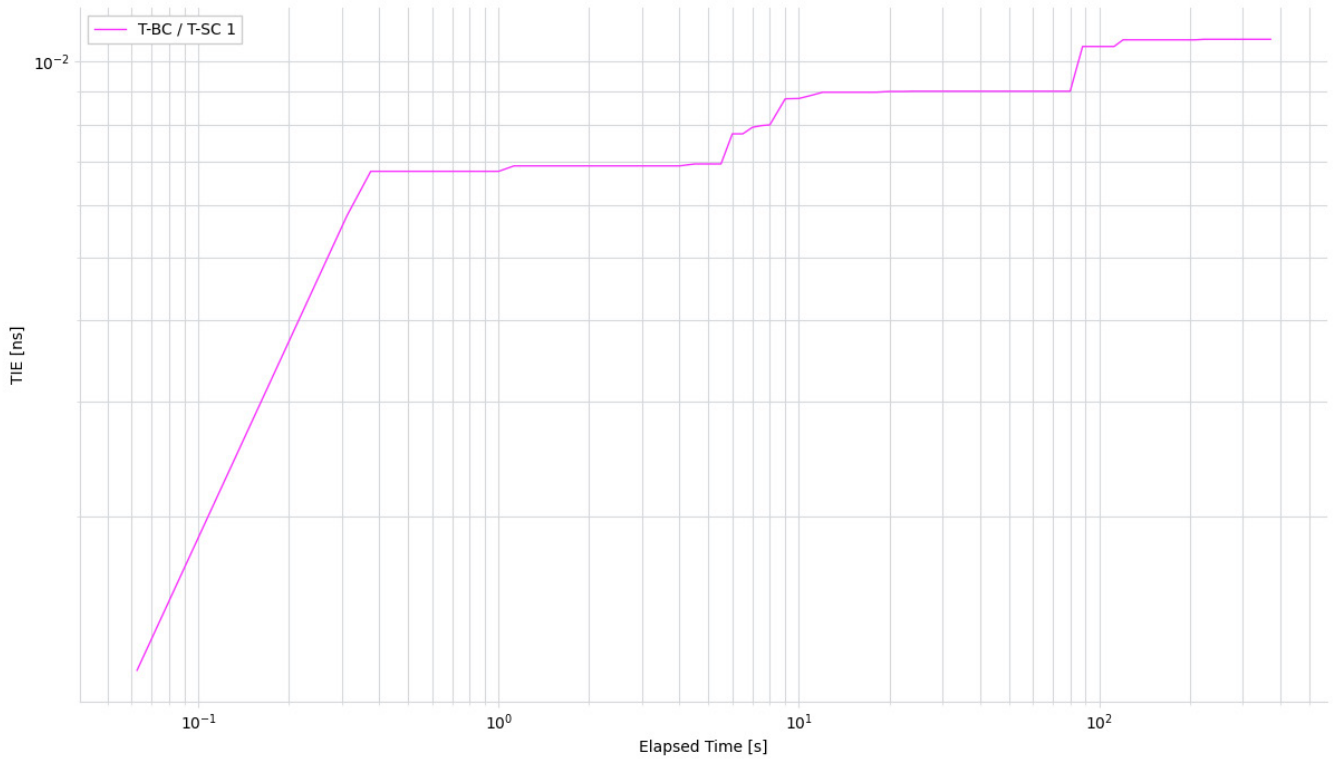

Figure 24. Phase Discontinuity – G.8262 EEC Option 1, 1.2Hz – MTIE

	T-BC / T-SC 1
Min [ns]	0.001
Max [ns]	0.011
Max-Min [ns]	0.01

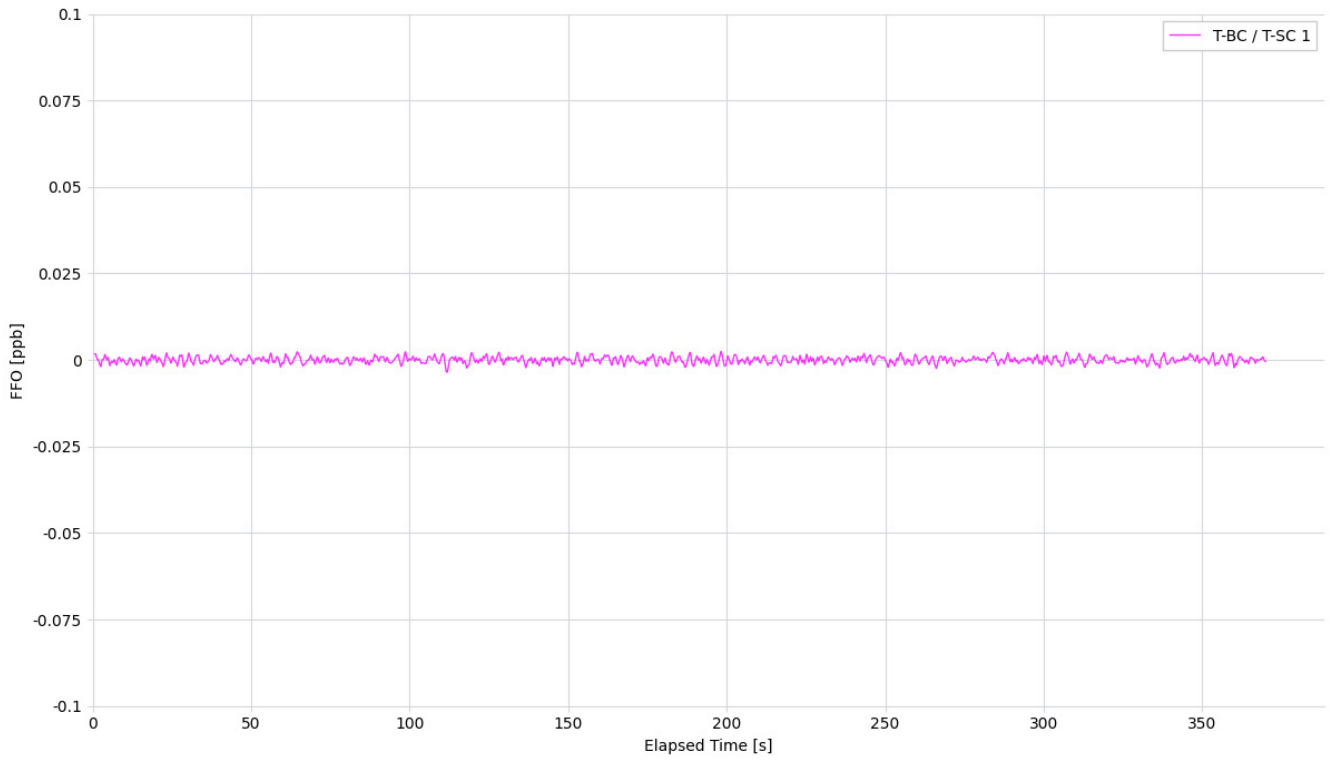

Figure 25. Phase Discontinuity – G.8262 EEC Option 1, 1.2Hz – FFO

	T-BC / T-SC 1
Mean [ppb]	-0.0
Min [ppb]	-0.004
Max [ppb]	0.002
Max-Min [ppb]	0.006

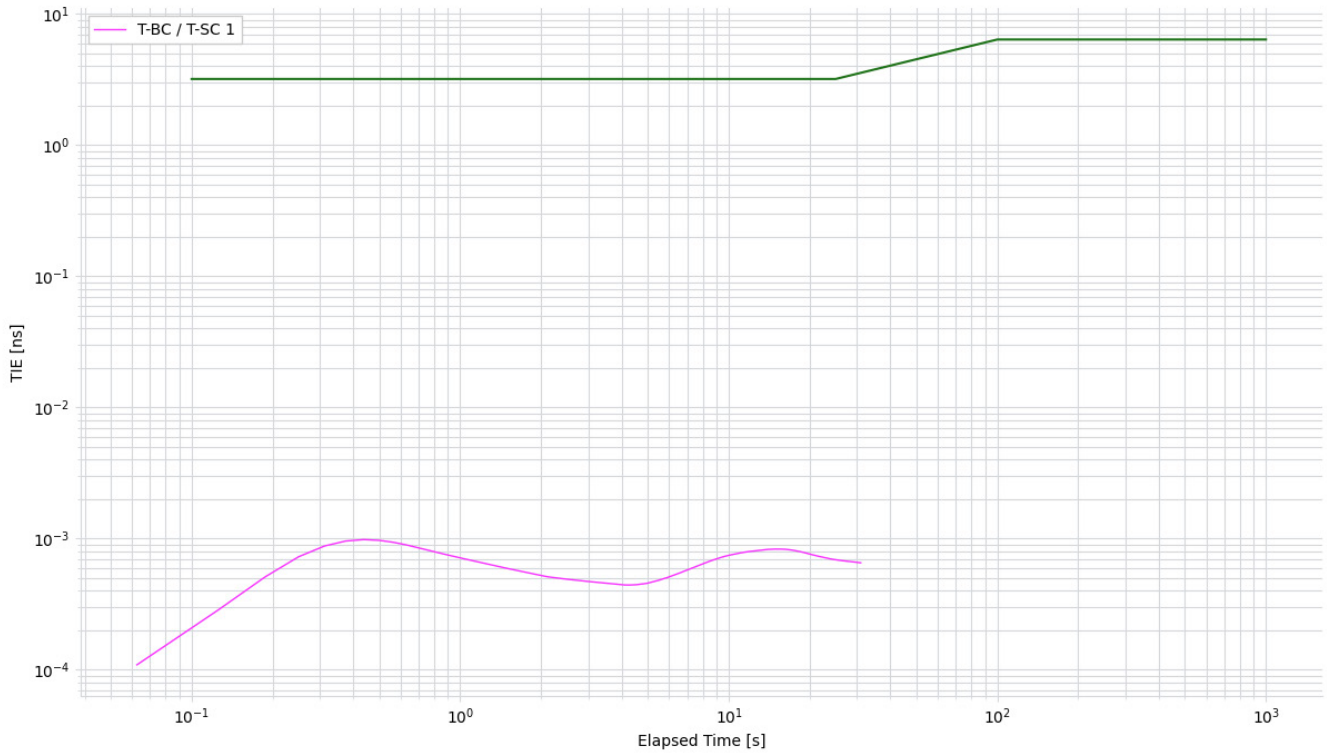

Figure 26. Phase Discontinuity – G.8262 EEC Option 1, 1.2Hz – TDEV

	T-BC / T-SC 1
Min [ns]	0.0
Max [ns]	0.001
Max-Min [ns]	0.001

6.2.2. Phase Discontinuity – G.8262 EEC Option 1, 10Hz

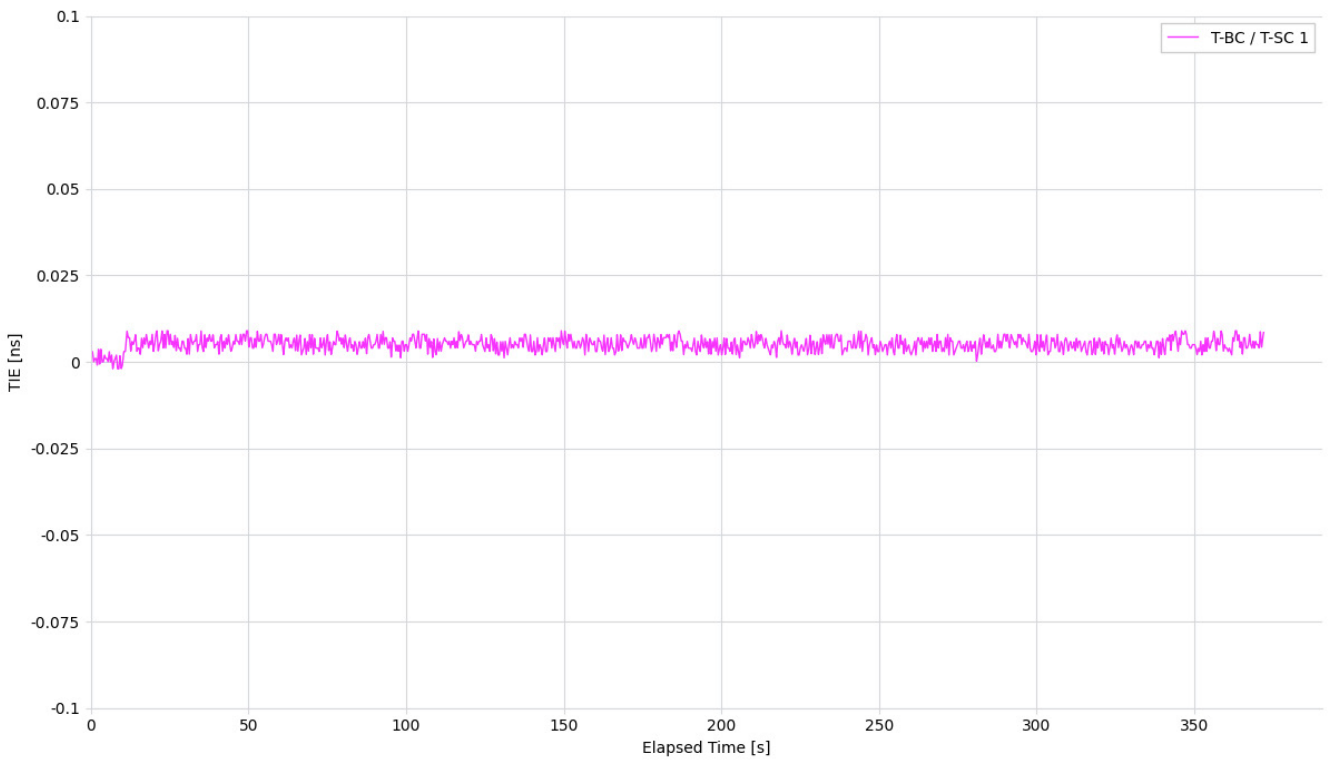

Figure 27. Phase Discontinuity – G.8262 EEC Option 1, 10Hz – TIE (no mask)

	T-BC / T-SC 1
Mean [ns]	0.005
Min [ns]	-0.002
Max [ns]	0.009
Max-Min [ns]	0.011

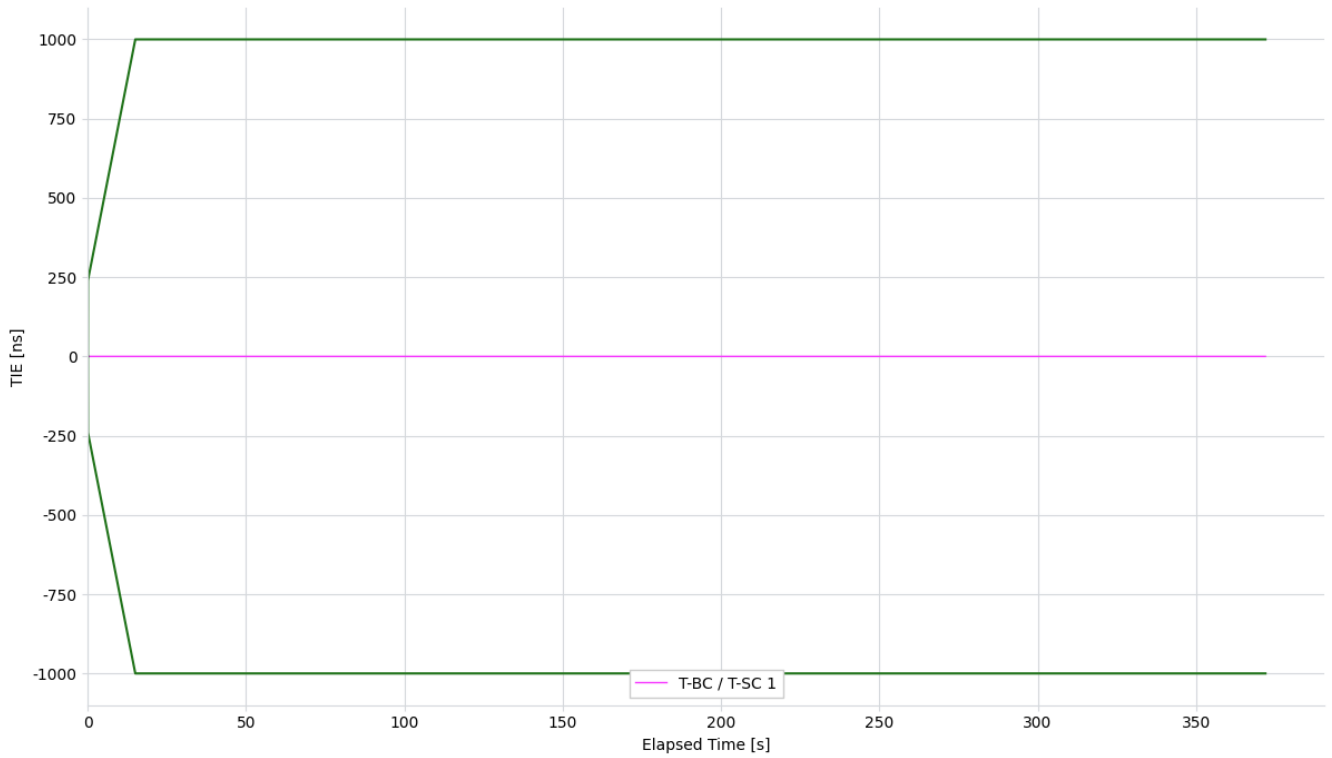

Figure 28. Phase Discontinuity – G.8262 EEC Option 1, 10Hz – TIE

	T-BC / T-SC 1
Mean [ns]	0.005
Min [ns]	-0.002
Max [ns]	0.009
Max-Min [ns]	0.011

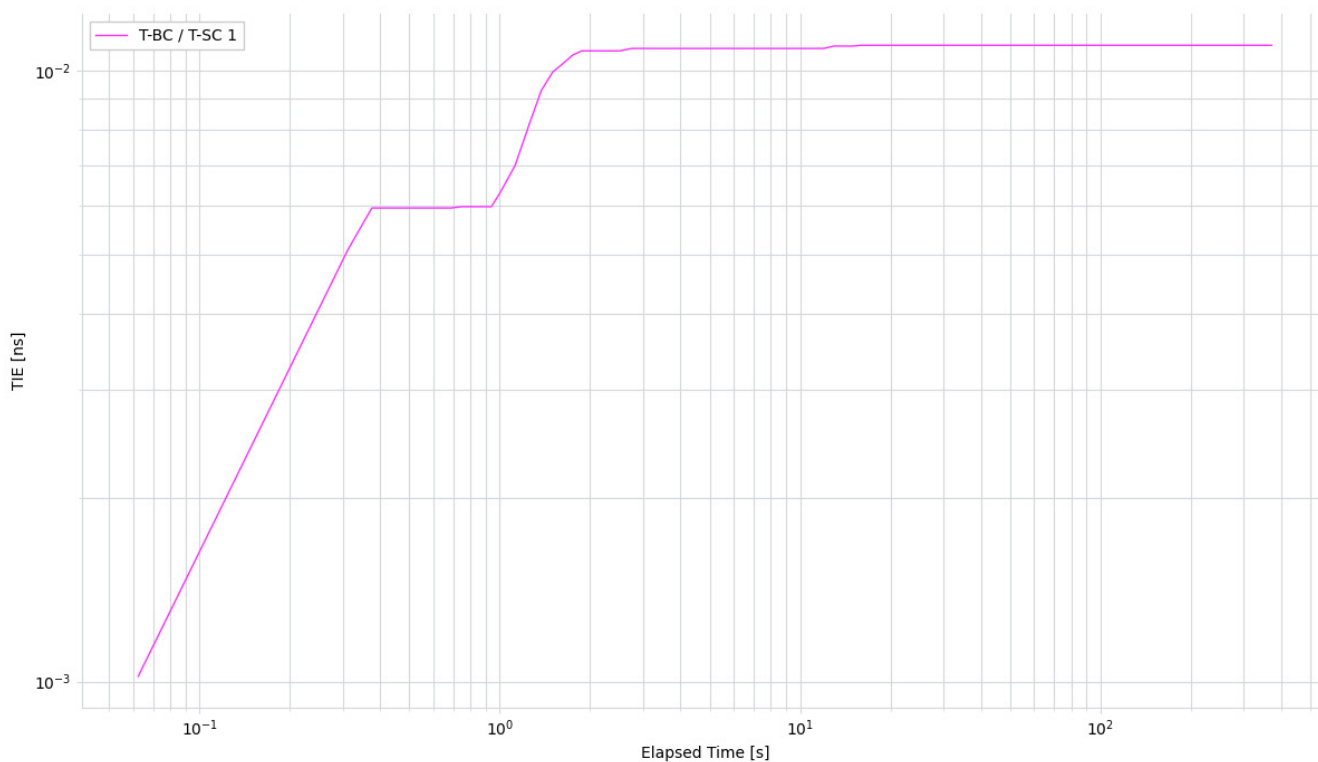

Figure 29. Phase Discontinuity – G.8262 EEC Option 1, 10Hz – MTIE

	T-BC / T-SC 1
Min [ns]	0.001
Max [ns]	0.011
Max-Min [ns]	0.01

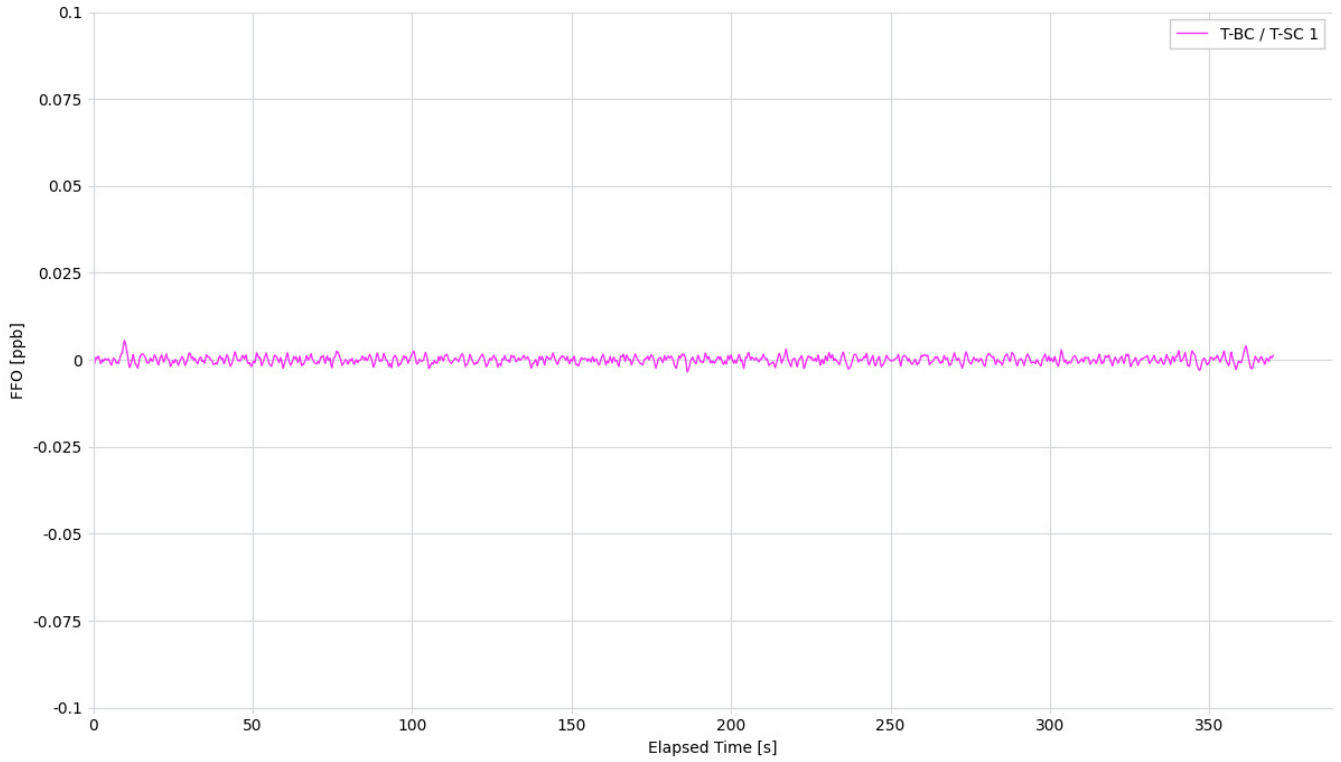

Figure 30. Phase Discontinuity – G.8262 EEC Option 1, 10Hz – FFO

	T-BC / T-SC 1
Mean [ppb]	0.0
Min [ppb]	-0.003
Max [ppb]	0.006
Max-Min [ppb]	0.009

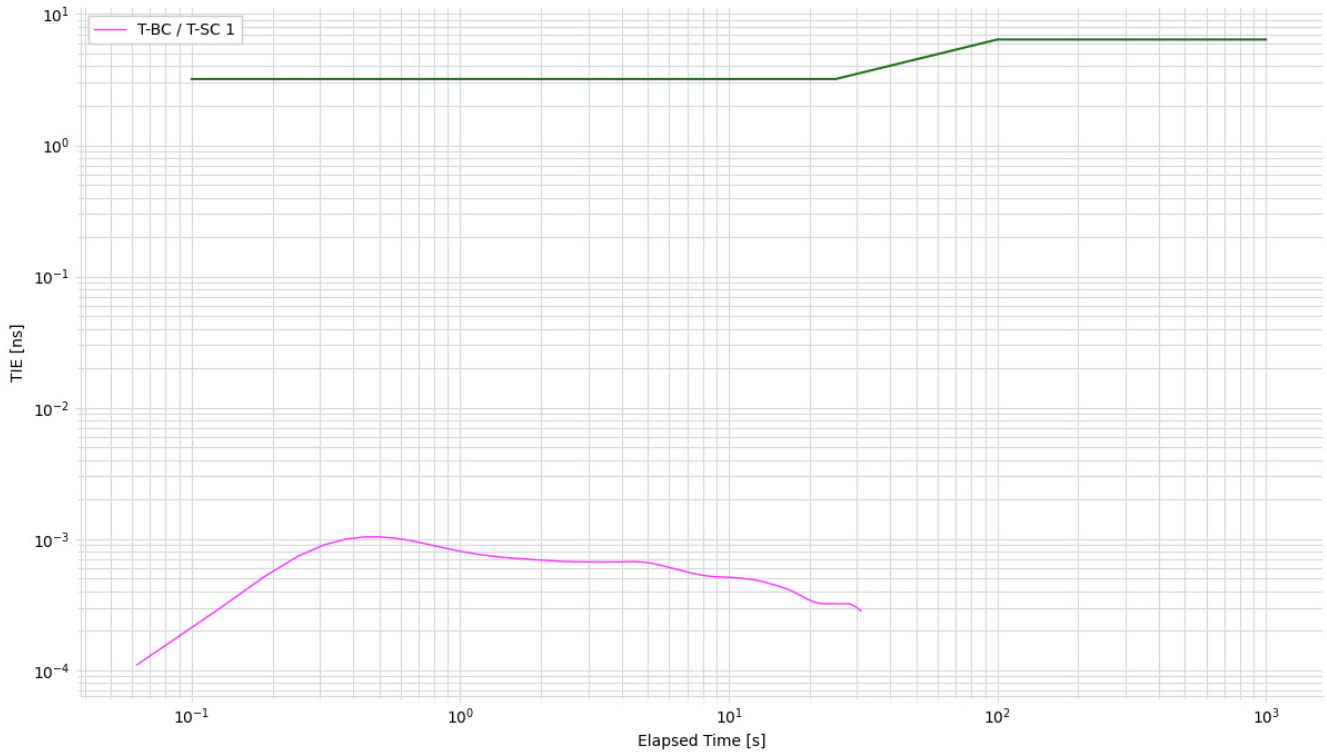

Figure 31. Phase Discontinuity – G.8262 EEC Option 1, 10Hz – TDEV

	T-BC / T-SC 1
Min [ns]	0.0
Max [ns]	0.001
Max-Min [ns]	0.001

6.2.3. Phase Discontinuity – G.8262 EEC Option 2, 0.1Hz

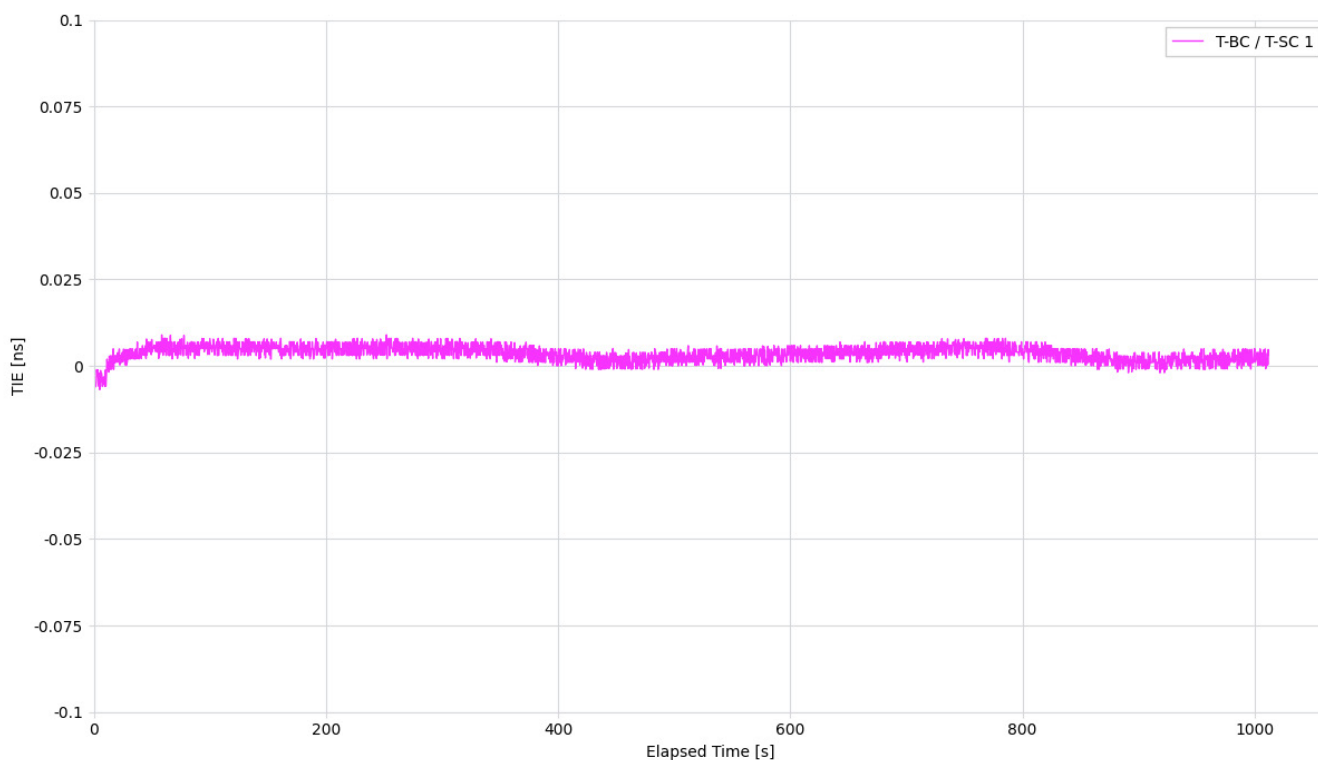

Figure 32. Phase Discontinuity – G.8262 EEC Option 2, 0.1Hz – TIE

	T-BC / T-SC 1
Mean [ns]	0.004
Min [ns]	-0.007
Max [ns]	0.009
Max-Min [ns]	0.016

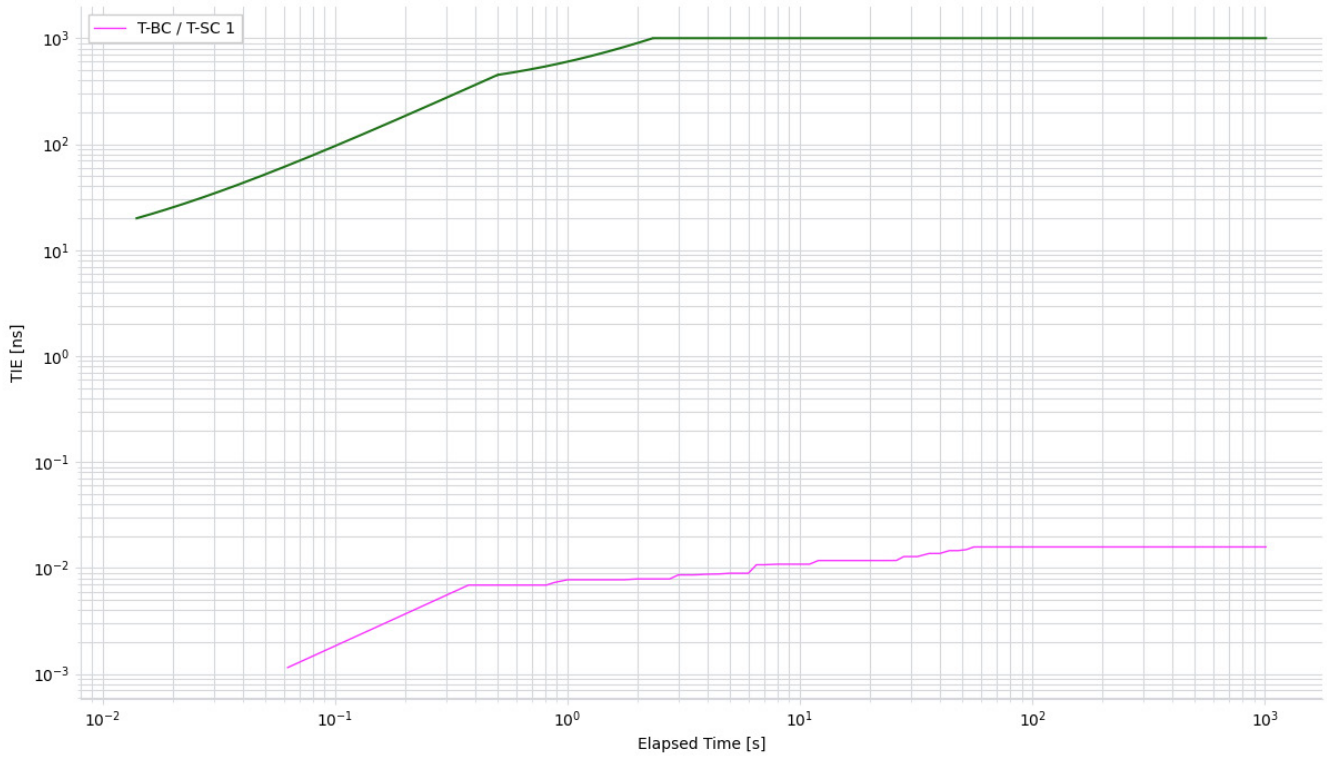

Figure 33. Phase Discontinuity – G.8262 EEC Option 2, 0.1Hz – MTIE

	T-BC / T-SC 1
Min [ns]	0.001
Max [ns]	0.016
Max-Min [ns]	0.015

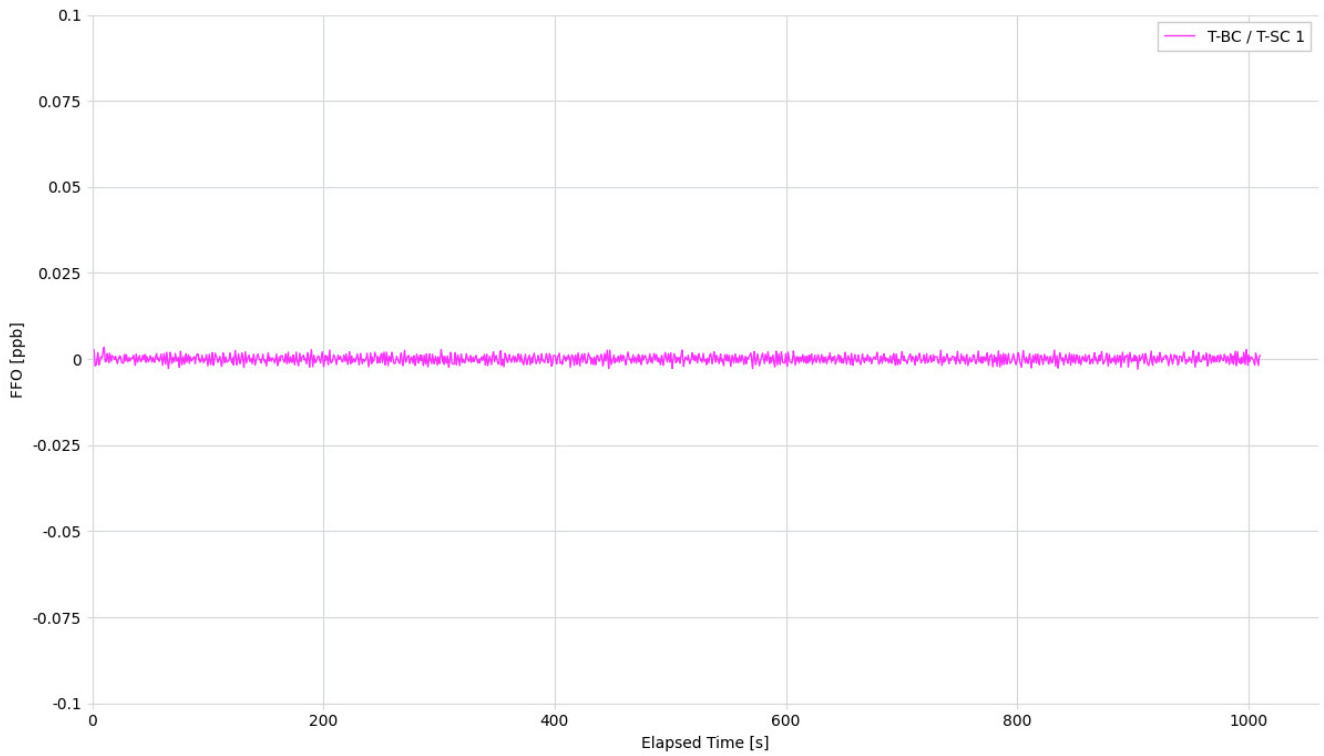

Figure 34. Phase Discontinuity – G.8262 EEC Option 2, 0.1Hz – FFO

	T-BC / T-SC 1
Mean [ppb]	-0.0
Min [ppb]	-0.003
Max [ppb]	0.003
Max-Min [ppb]	0.006

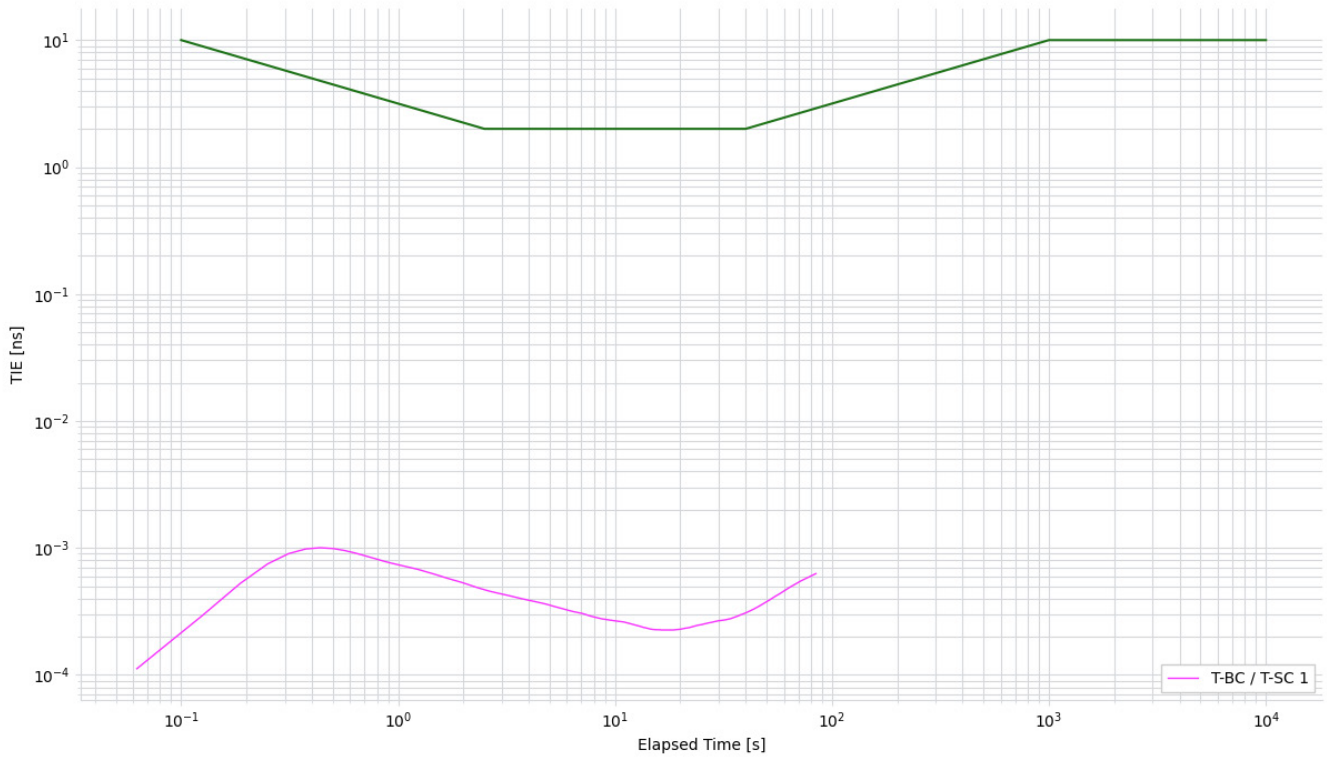

Figure 35. Phase Discontinuity – G.8262 EEC Option 2, 0.1Hz – TDEV

	T-BC / T-SC 1
Min [ns]	0.0
Max [ns]	0.001
Max-Min [ns]	0.001

6.2.4. Phase Discontinuity – G.8262.1 eEEC, 3Hz

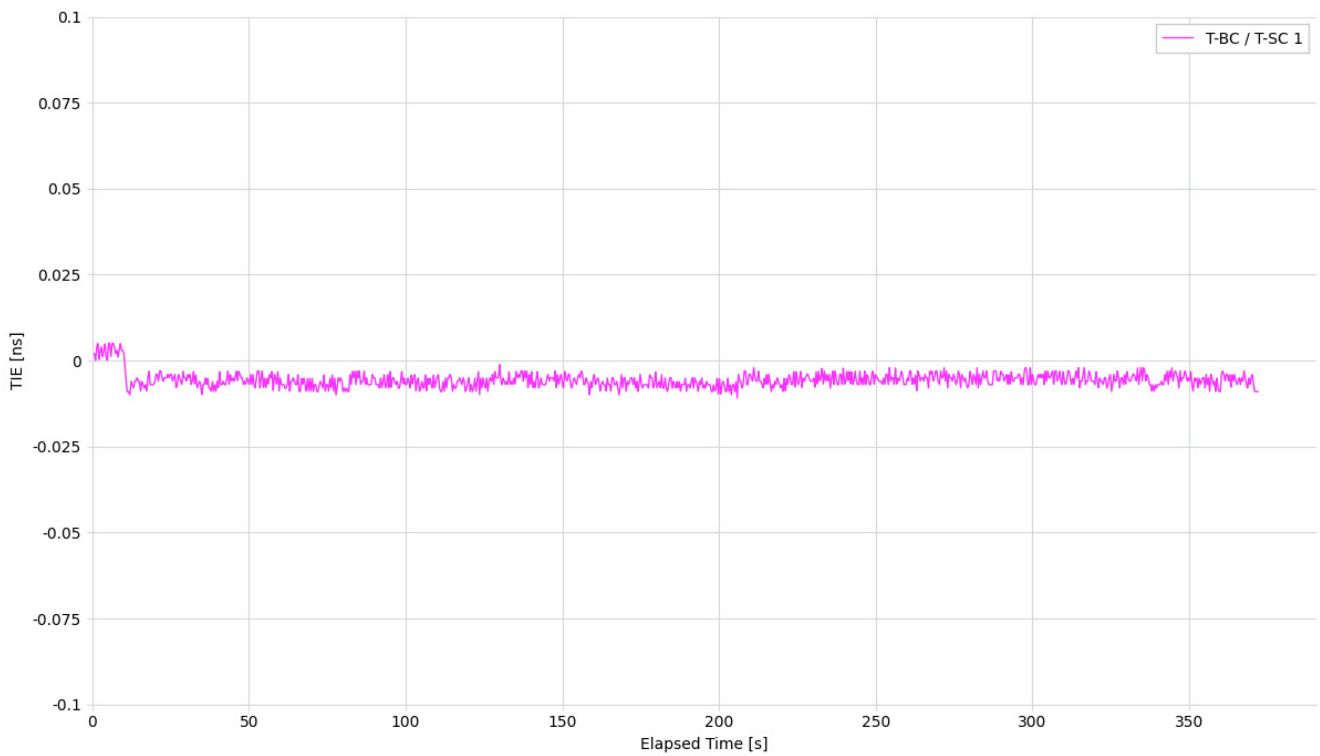

Figure 36. Phase Discontinuity – G.8262.1 eEEC, 3Hz – TIE (no mask)

	T-BC / T-SC 1
Mean [ns]	-0.006
Min [ns]	-0.011
Max [ns]	0.005
Max-Min [ns]	0.016

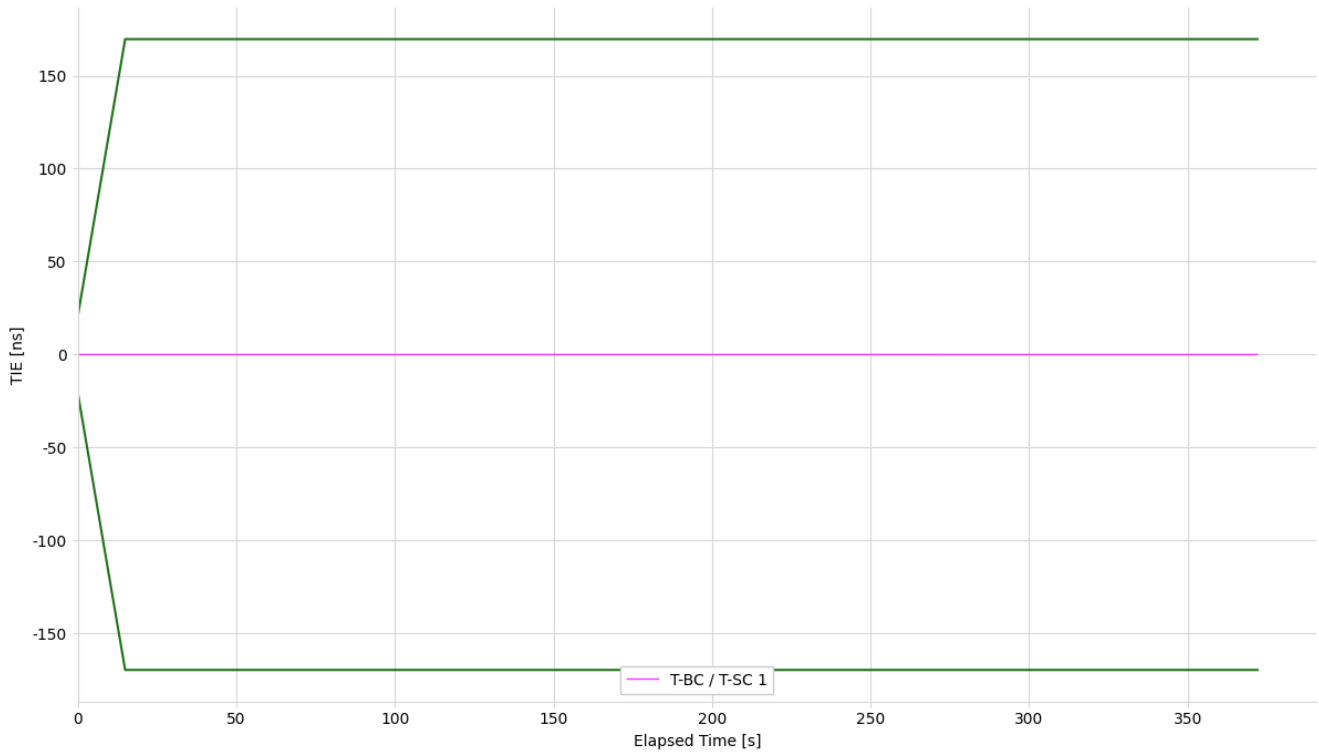

Figure 37. Phase Discontinuity – G.8262.1 eEEC, 3Hz – TIE

	T-BC / T-SC 1
Mean [ns]	-0.006
Min [ns]	-0.011
Max [ns]	0.005
Max-Min [ns]	0.016

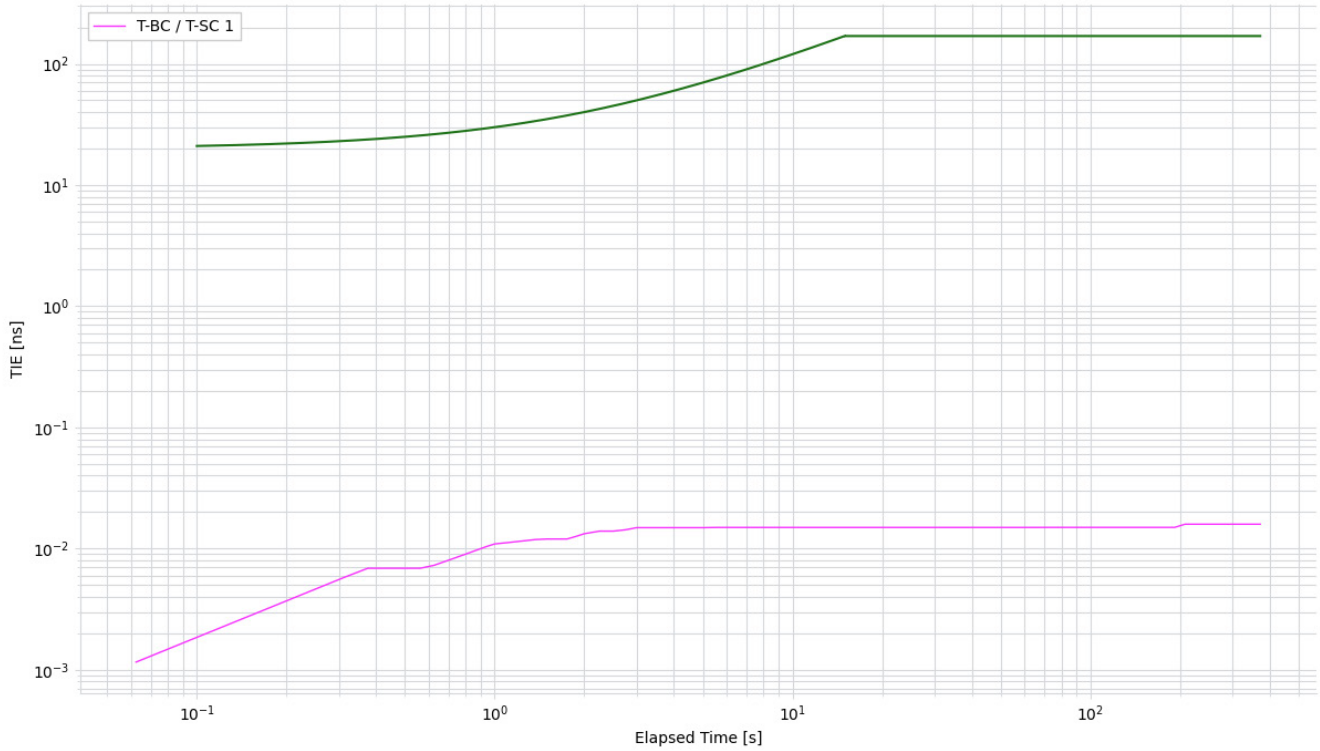

Figure 38. Phase Discontinuity – G.8262.1 eEEC, 3Hz – MTIE

	T-BC / T-SC 1
Min [ns]	0.001
Max [ns]	0.016
Max-Min [ns]	0.015

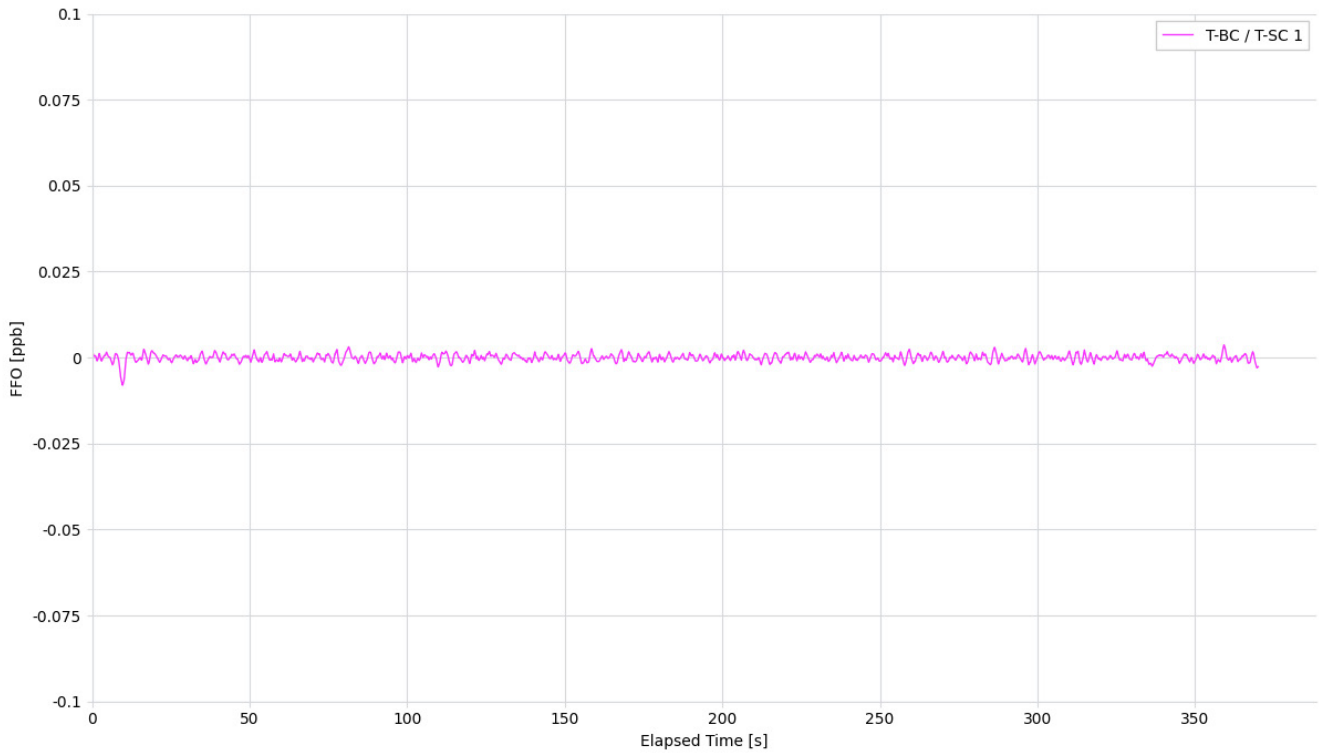

Figure 39. Phase Discontinuity – G.8262.1 eEEC, 3Hz – FFO

	T-BC / T-SC 1
Mean [ppb]	-0.0
Min [ppb]	-0.008
Max [ppb]	0.004
Max-Min [ppb]	0.012

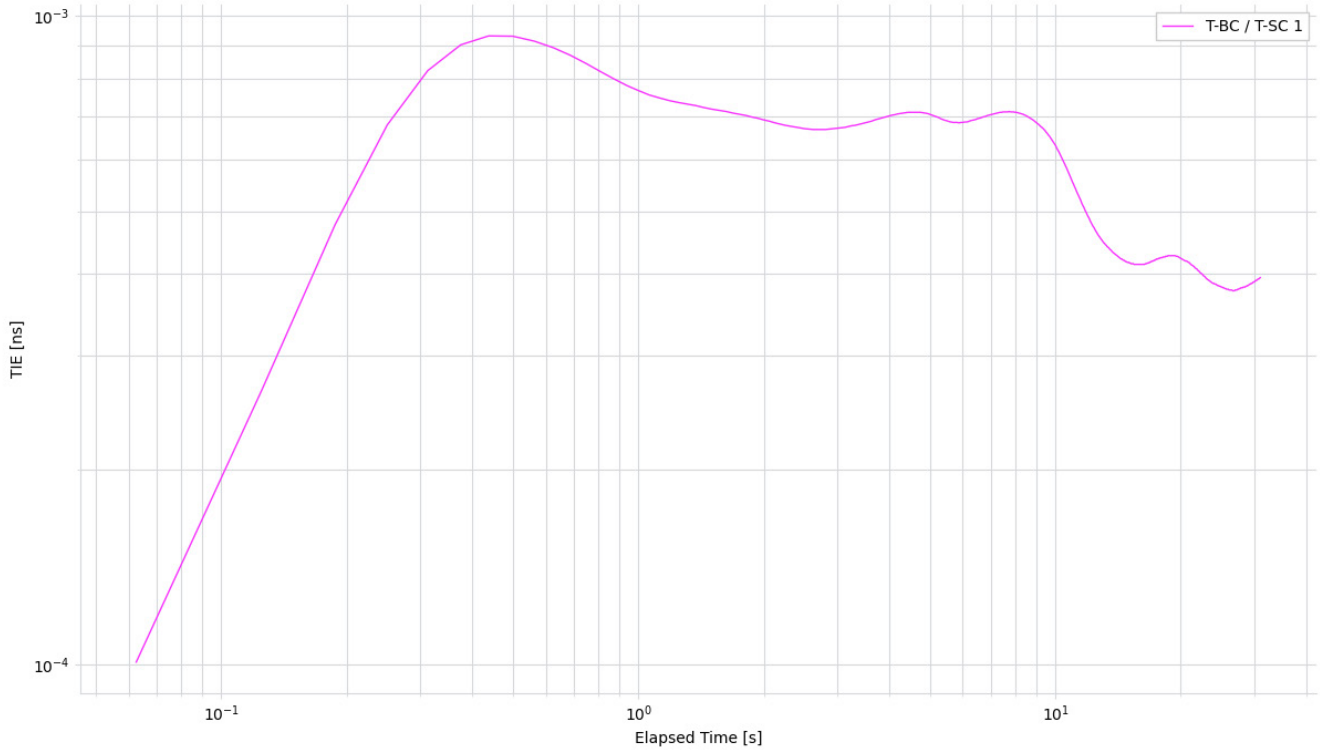

Figure 40. Phase Discontinuity – G.8262.1 eEEC, 3Hz – TDEV

	T-BC / T-SC 1
Min [ns]	0.0
Max [ns]	0.001
Max-Min [ns]	0.001

6.3 Short-term Phase Transient Response

Short-term phase transient response requirement reflects the performance of the DUT in cases when the (selected) input reference is lost due to a failure in the reference path and a second reference input signal, traceable to the same reference clock, is available simultaneously, or shortly after the detection of the failure (see [Figure 1](#) for the equipment configuration).

The test was carried out by providing reference clock inputs on IN_A and IN_B from the Frequency Generator which are 180° out of phase from each other. The PLL is locked to the clock signal from IN_A for a period of time. A transient is produced by turning off the input reference signal for 11 seconds, and during this time, the clock on IN_B is unavailable. The DPLL goes into holdover during the 11 second period as no other reference is available. After 11 seconds, the reference signal on IN_B is turned ON and PLL locks to the newly available reference signal. The output from the DUT is available on OUT_0 and the phase time error is captured using the Frequency Counter. The results of the given transient are plotted against the applicable standard profiles.

- Locked to IN_A → Holdover (11s) → Locked to IN_B

6.3.1. Short-term Phase Transient Response – G.8262 EEC Option 1, 1.2Hz

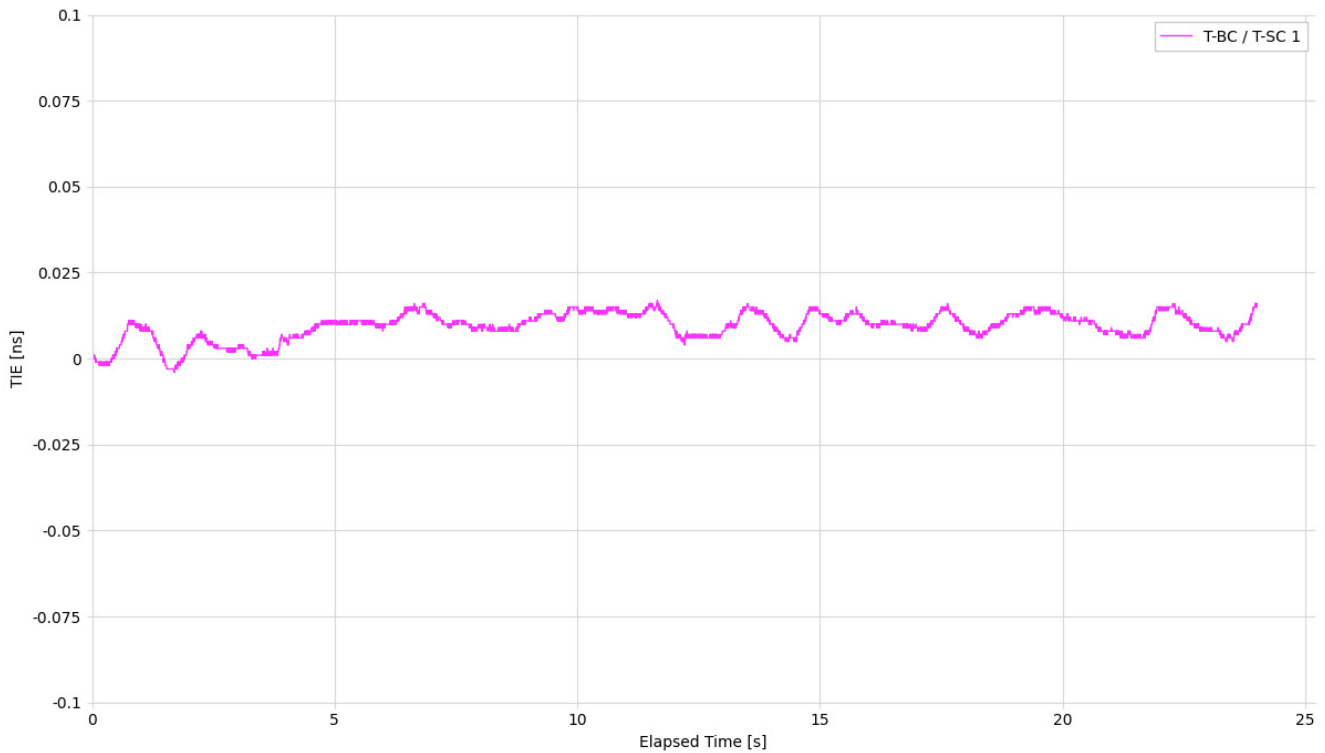

Figure 41. Short-term Phase Transient Response – G.8262 EEC Option 1, 1.2Hz – TIE (no mask)

	T-BC / T-SC 1
Mean [ns]	0.009
Min [ns]	-0.004
Max [ns]	0.017
Max-Min [ns]	0.021

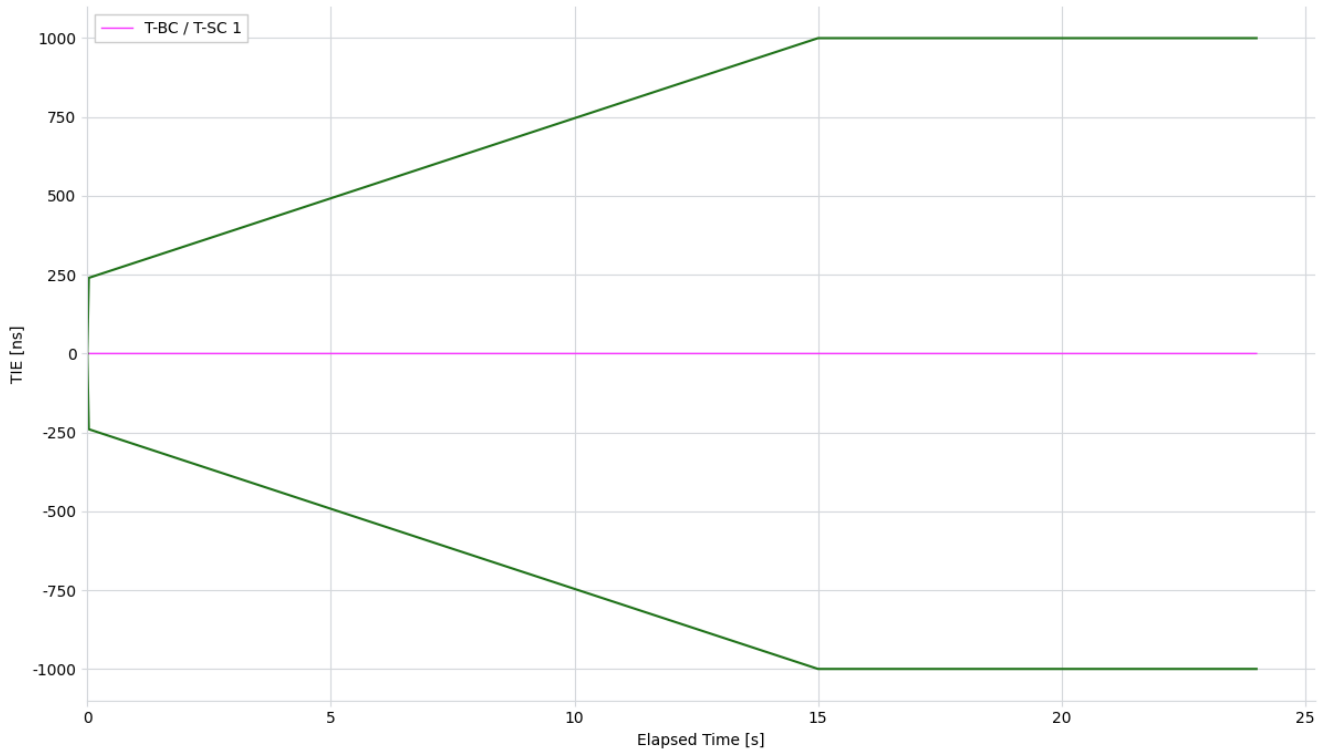

Figure 42. Short-term Phase Transient Response – G.8262 EEC Option 1, 1.2Hz – TIE

	T-BC / T-SC 1
Mean [ns]	0.009
Min [ns]	-0.004
Max [ns]	0.017
Max-Min [ns]	0.021

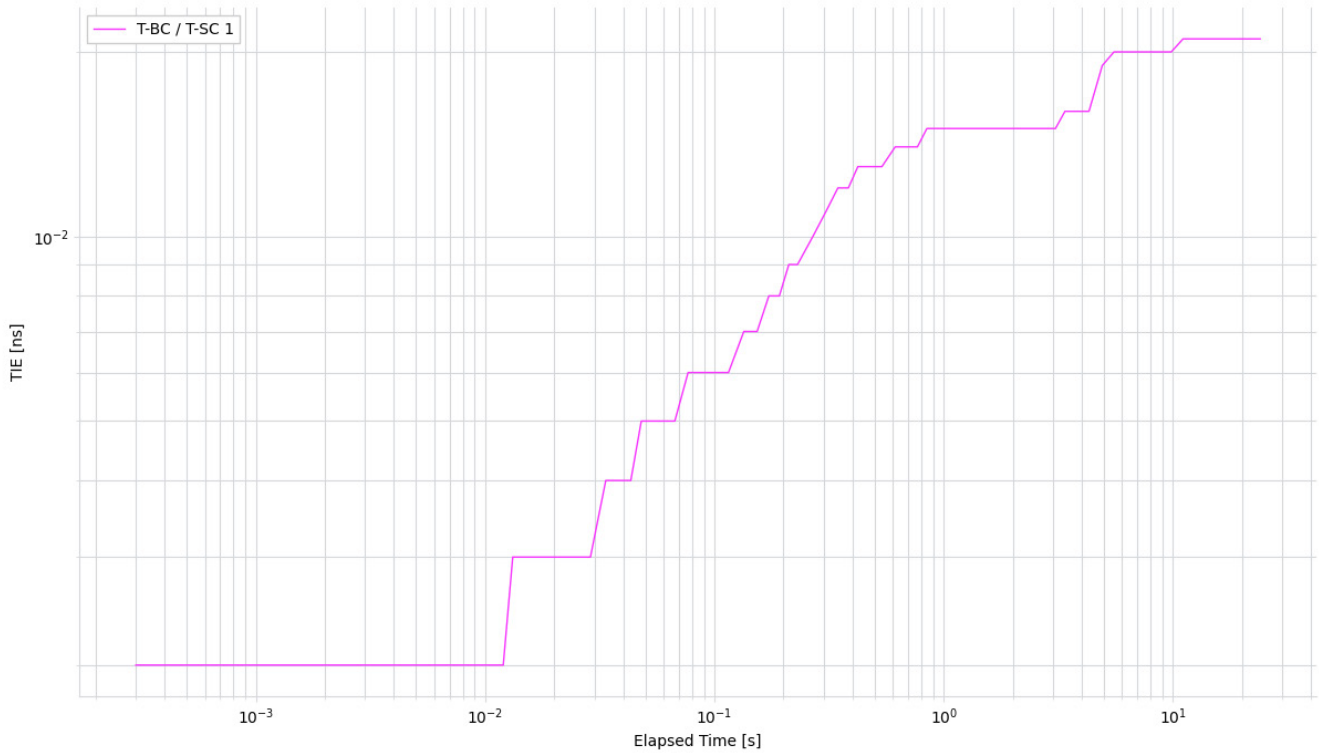

Figure 43. Short-term Phase Transient Response – G.8262 EEC Option 1, 1.2Hz – MTIE

	T-BC / T-SC 1
Min [ns]	0.002
Max [ns]	0.021
Max-Min [ns]	0.019

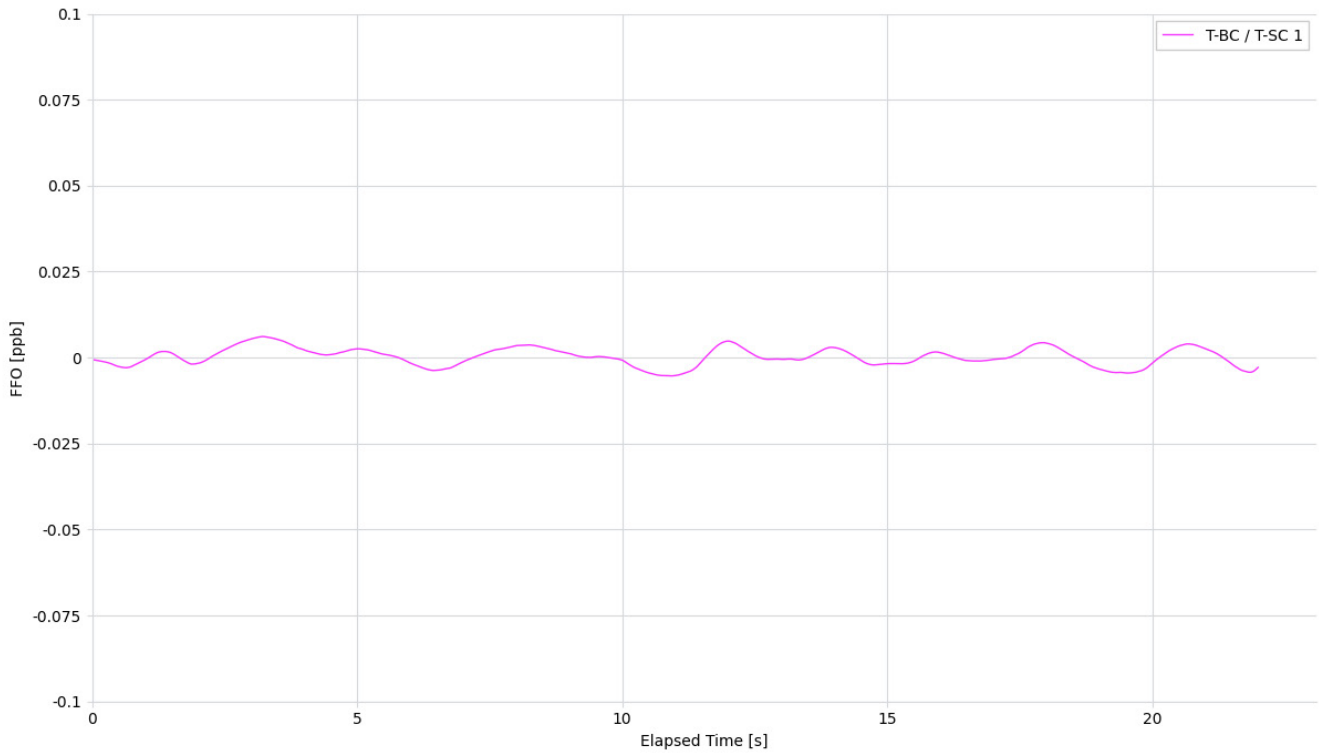

Figure 44. Short-term Phase Transient Response – G.8262 EEC Option 1, 1.2Hz – FFO

	T-BC / T-SC 1
Mean [ppb]	0.0
Min [ppb]	-0.005
Max [ppb]	0.006
Max-Min [ppb]	0.011

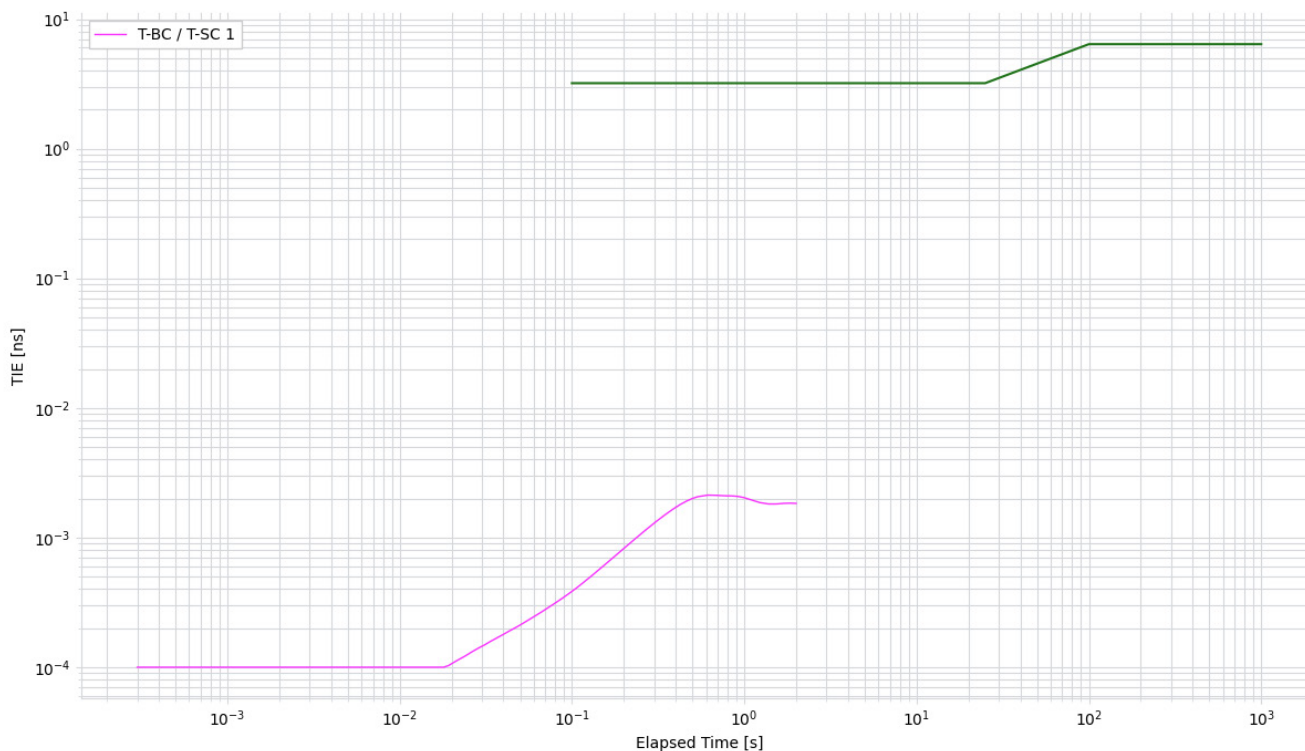

Figure 45. Short-term Phase Transient Response – G.8262 EEC Option 1, 1.2Hz – TDEV

	T-BC / T-SC 1
Min [ns]	0.0
Max [ns]	0.002
Max-Min [ns]	0.002

6.3.2. Short-term Phase Transient Response – G.8262 EEC Option 1, 10Hz

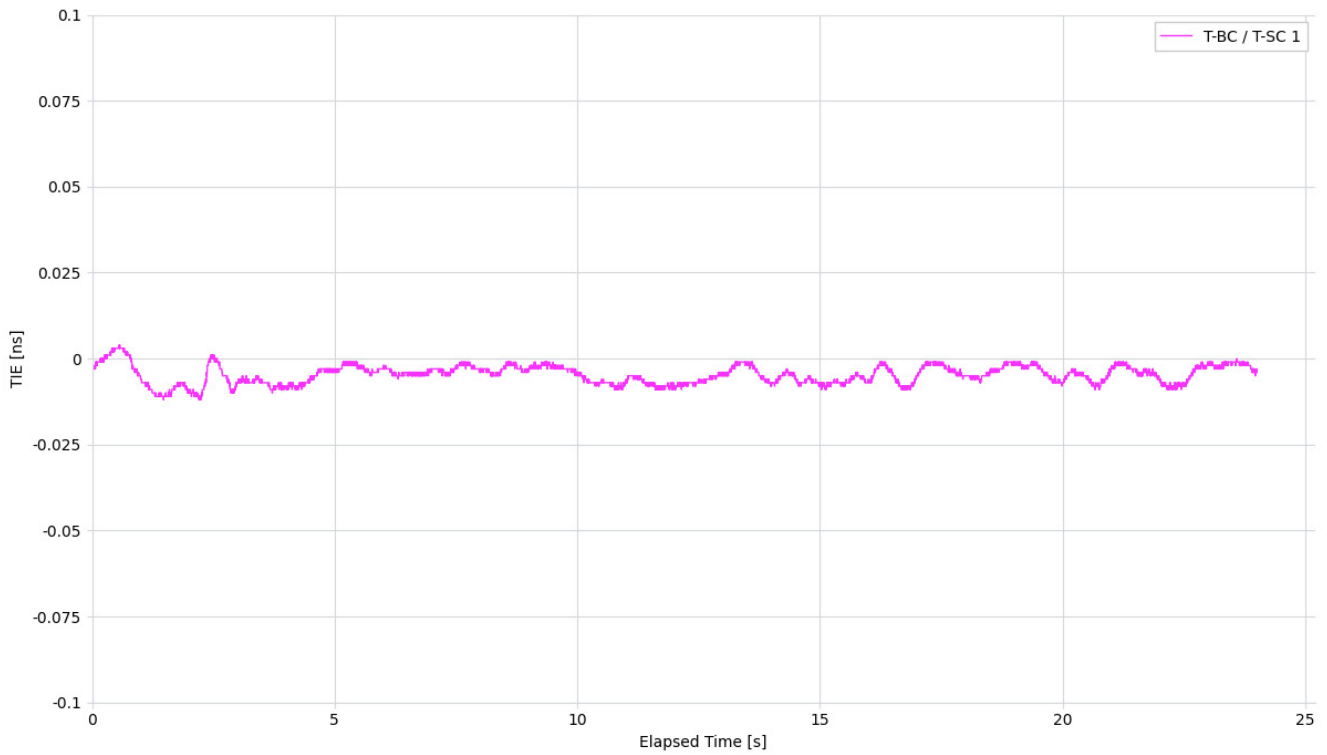

Figure 46. Short-term Phase Transient Response – G.8262 EEC Option 1, 10Hz – TIE (no mask)

	T-BC / T-SC 1
Mean [ns]	-0.005
Min [ns]	-0.012
Max [ns]	0.004
Max-Min [ns]	0.016

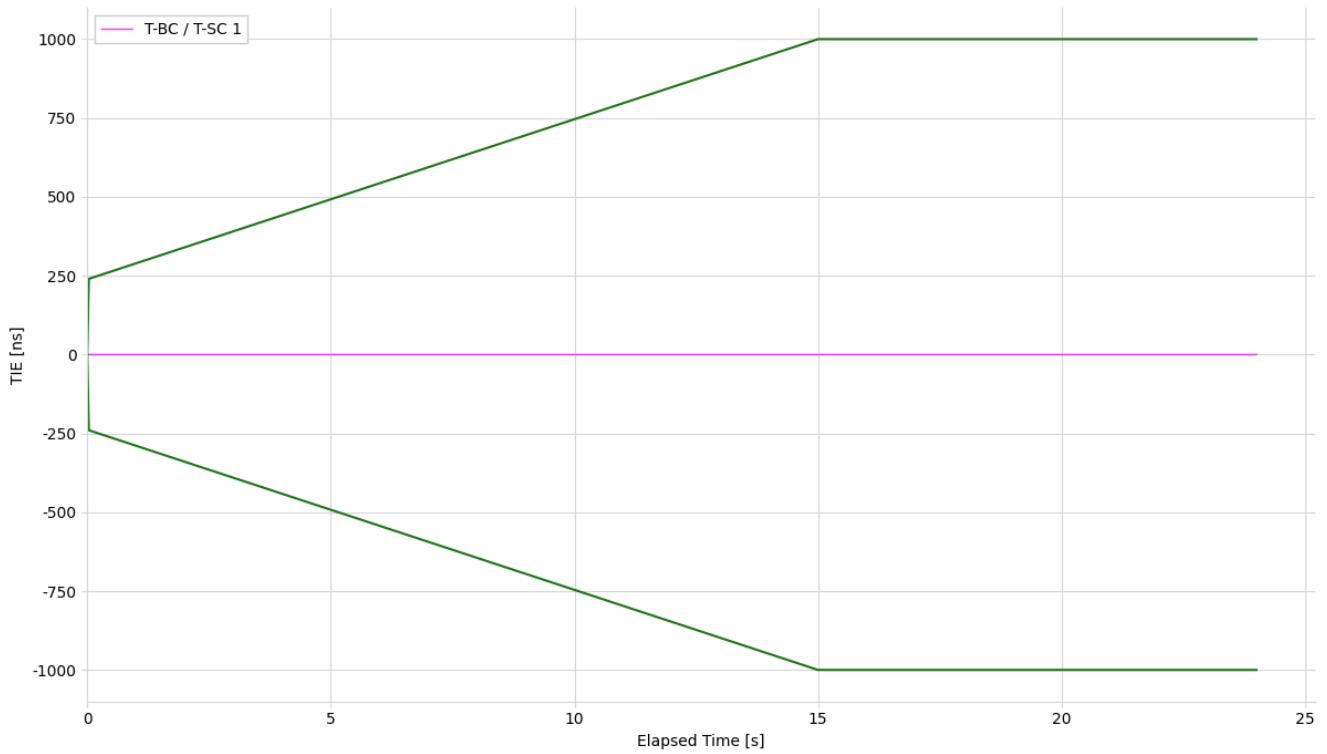

Figure 47. Short-term Phase Transient Response – G.8262 EEC Option 1, 10Hz – TIE

	T-BC / T-SC 1
Mean [ns]	-0.005
Min [ns]	-0.012
Max [ns]	0.004
Max-Min [ns]	0.016

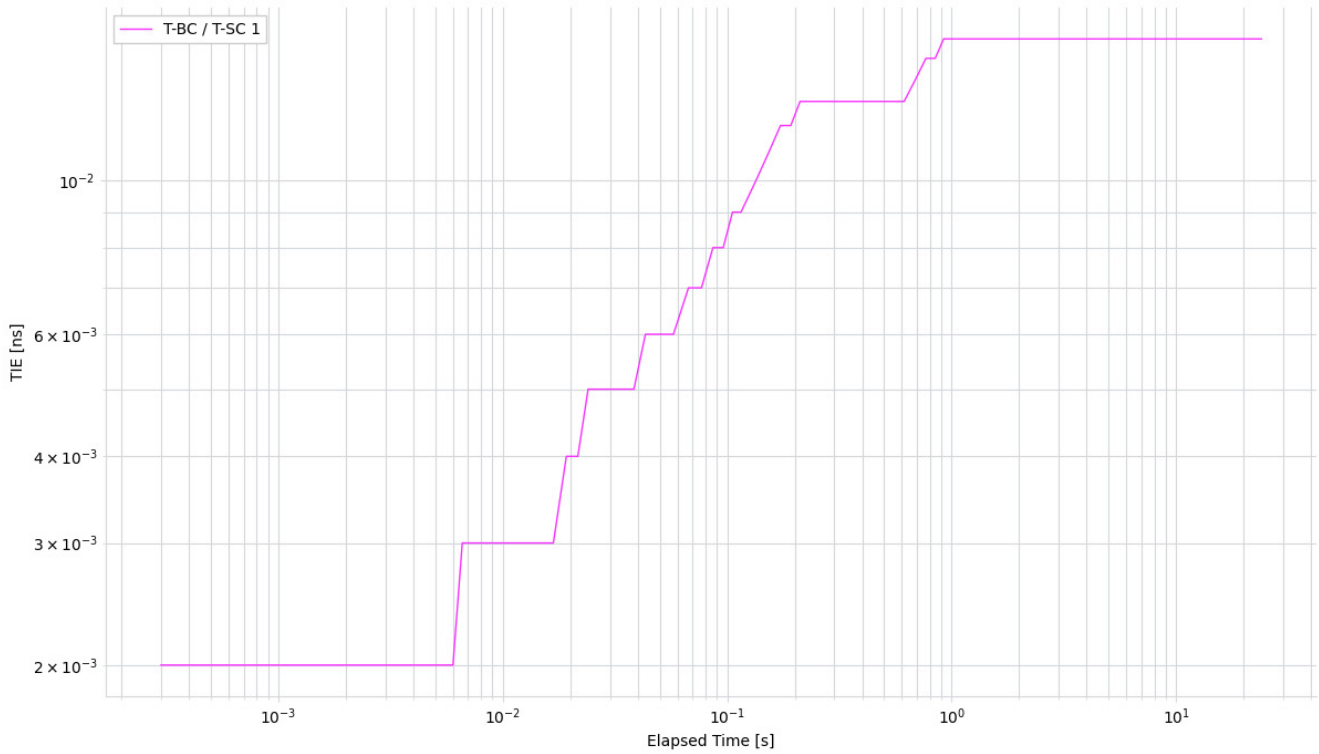

Figure 48. Short-term Phase Transient Response – G.8262 EEC Option 1, 10Hz – MTIE

	T-BC / T-SC 1
Min [ns]	0.002
Max [ns]	0.016
Max-Min [ns]	0.014

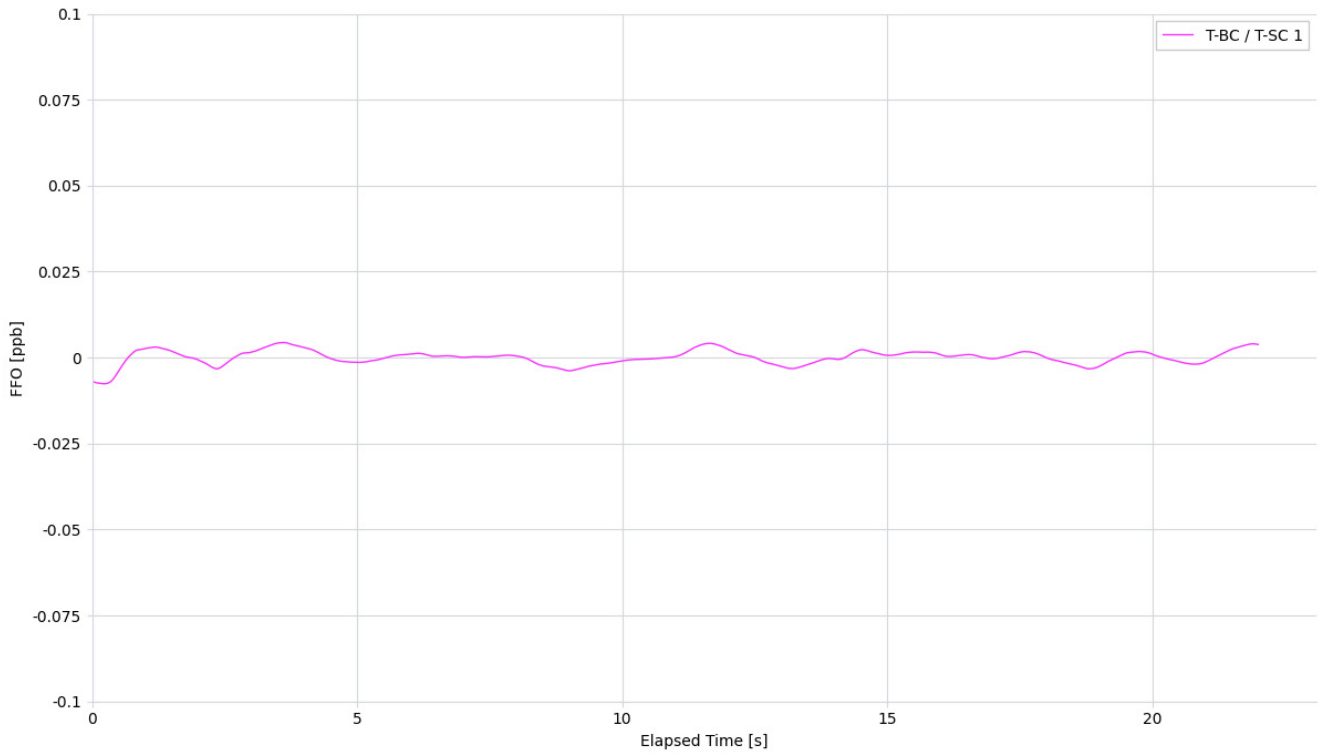

Figure 49. Short-term Phase Transient Response – G.8262 EEC Option 1, 10Hz – FFO

	T-BC / T-SC 1
Mean [ppb]	0.0
Min [ppb]	-0.008
Max [ppb]	0.004
Max-Min [ppb]	0.012

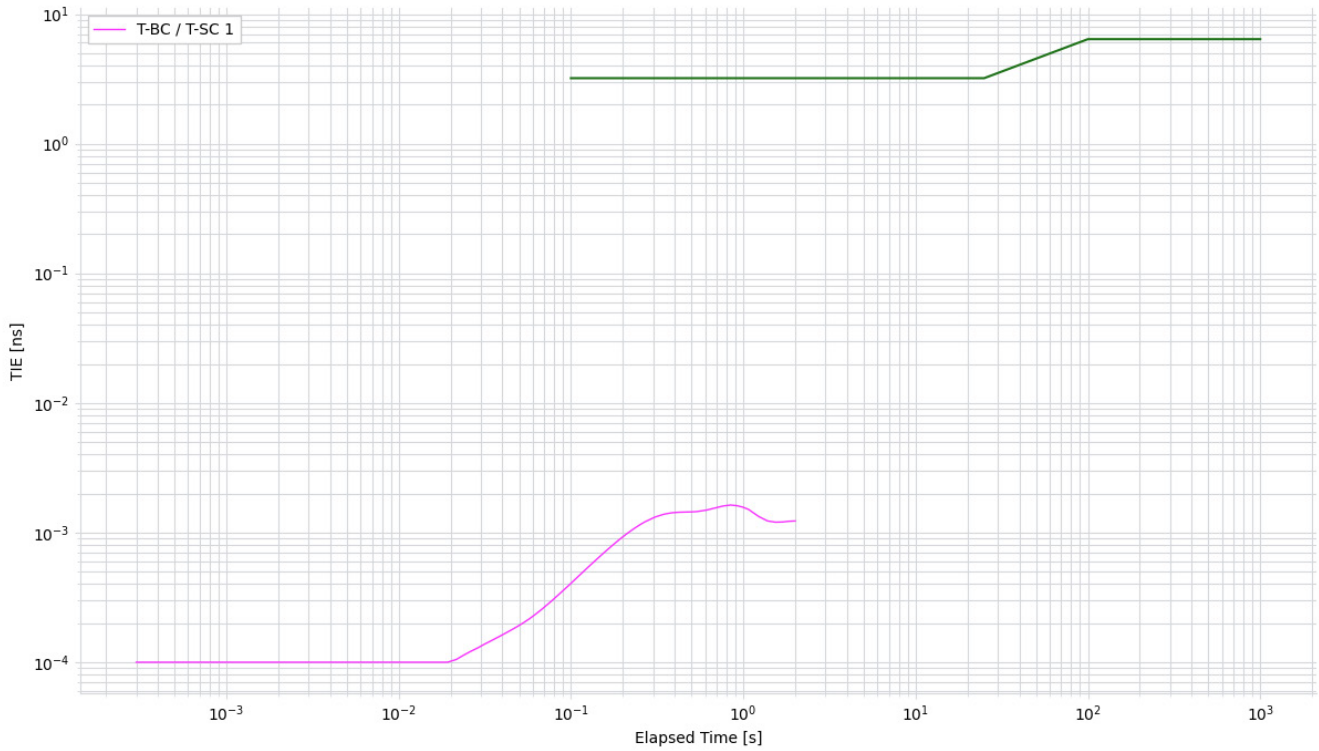

Figure 50. Short-term Phase Transient Response – G.8262 EEC Option 1, 10Hz – TDEV

	T-BC / T-SC 1
Min [ns]	0.0
Max [ns]	0.002
Max-Min [ns]	0.002

6.3.3. Short-term Phase Transient Response – G.8262 EEC Option 2, 0.1Hz

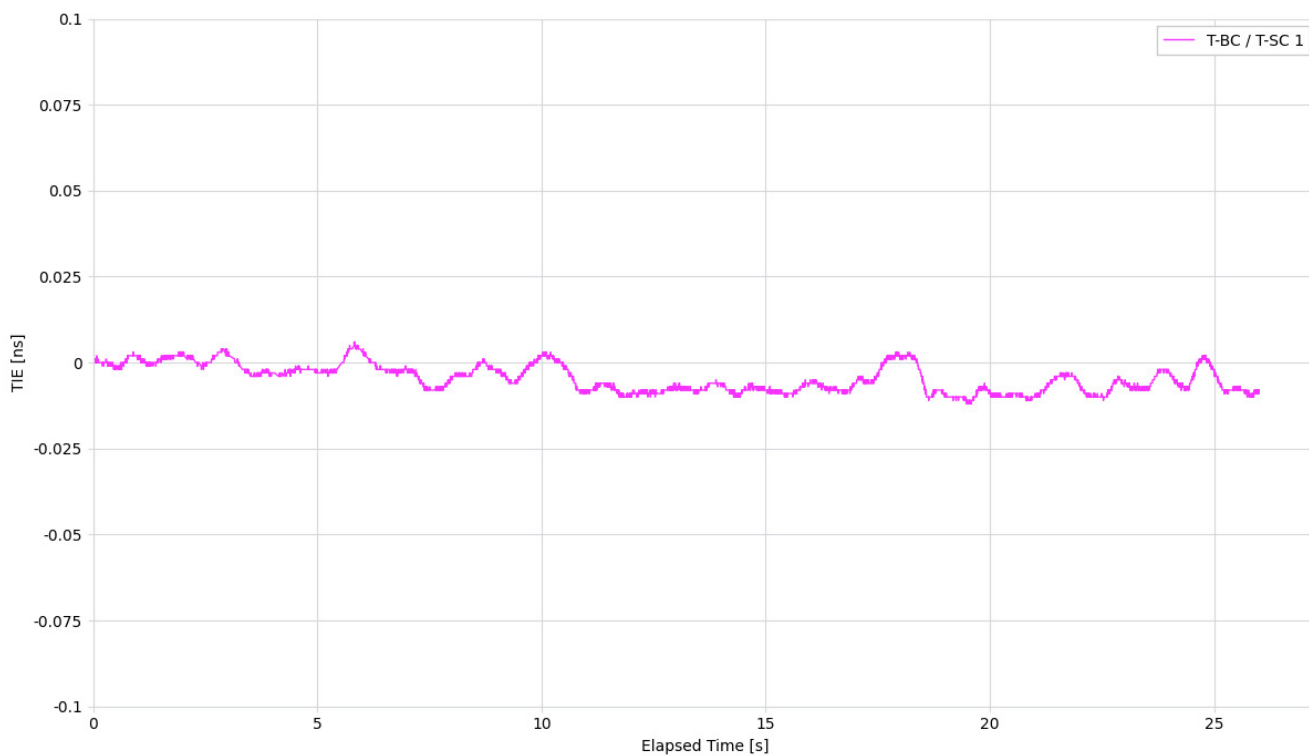

Figure 51. Short-term Phase Transient Response – G.8262 EEC Option 2, 0.1Hz – TIE

	T-BC / T-SC 1
Mean [ns]	-0.005
Min [ns]	-0.012
Max [ns]	0.006
Max-Min [ns]	0.018

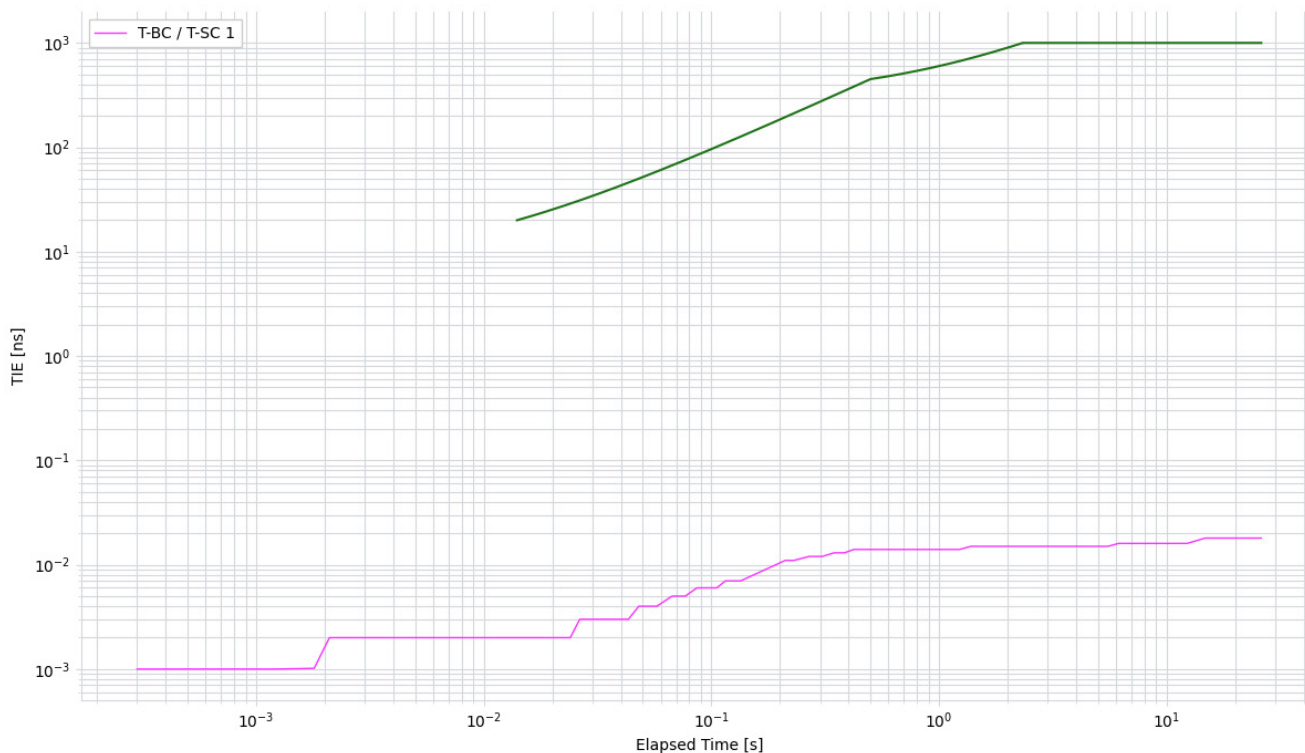

Figure 52. Short-term Phase Transient Response – G.8262 EEC Option 2, 0.1Hz – MTIE

	T-BC / T-SC 1
Min [ns]	0.001
Max [ns]	0.018
Max-Min [ns]	0.017

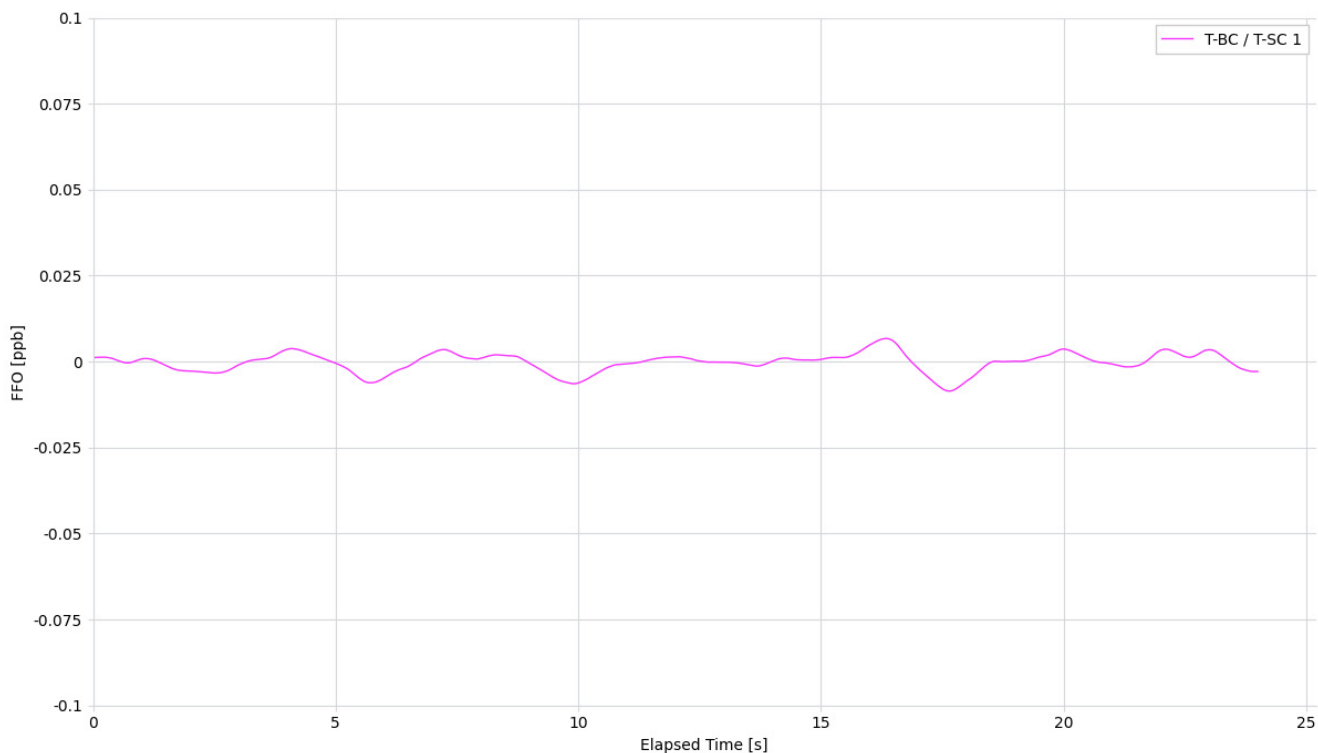

Figure 53. Short-term Phase Transient Response – G.8262 EEC Option 2, 0.1Hz – FFO

	T-BC / T-SC 1
Mean [ppb]	-0.0
Min [ppb]	-0.009
Max [ppb]	0.007
Max-Min [ppb]	0.015

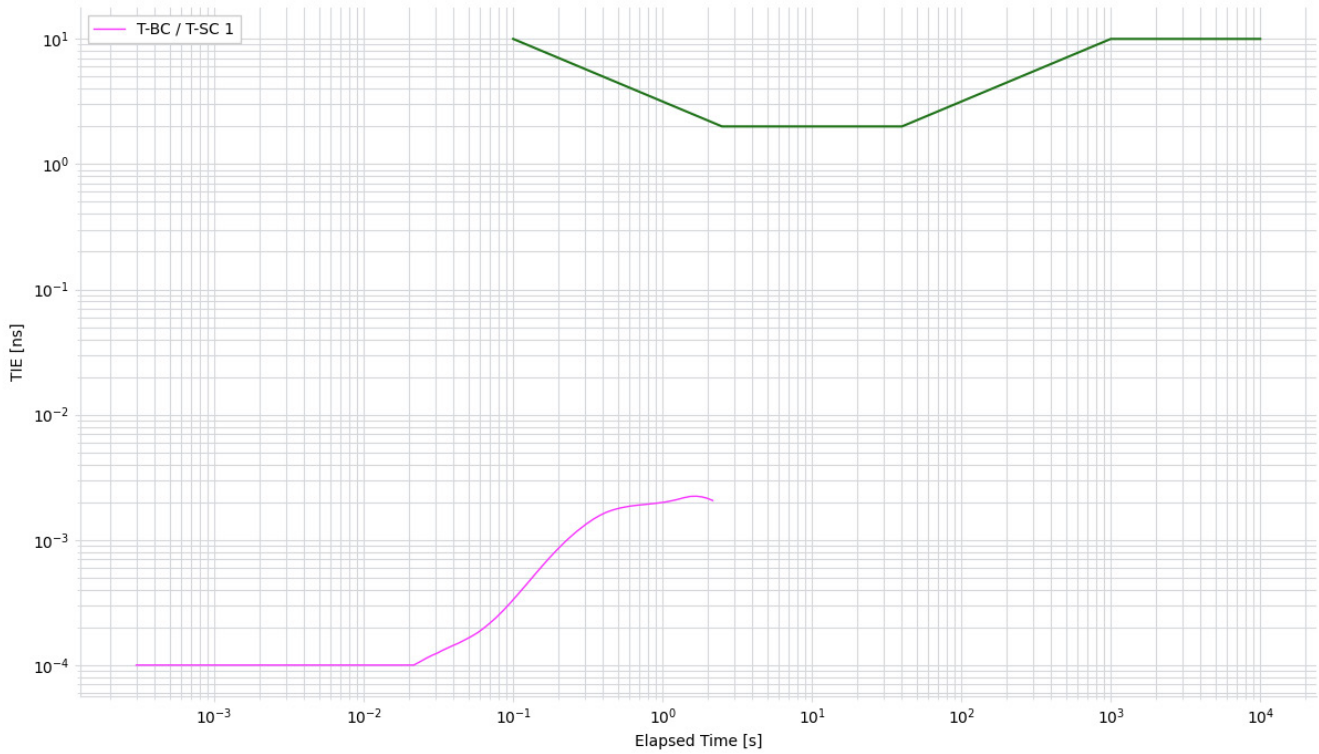

Figure 54. Short-term Phase Transient Response – G.8262 EEC Option 2, 0.1Hz – TDEV

	T-BC / T-SC 1
Min [ns]	0.0
Max [ns]	0.002
Max-Min [ns]	0.002

6.3.4. Short-term Phase Transient Response – G.8262.1 eEEC, 3Hz

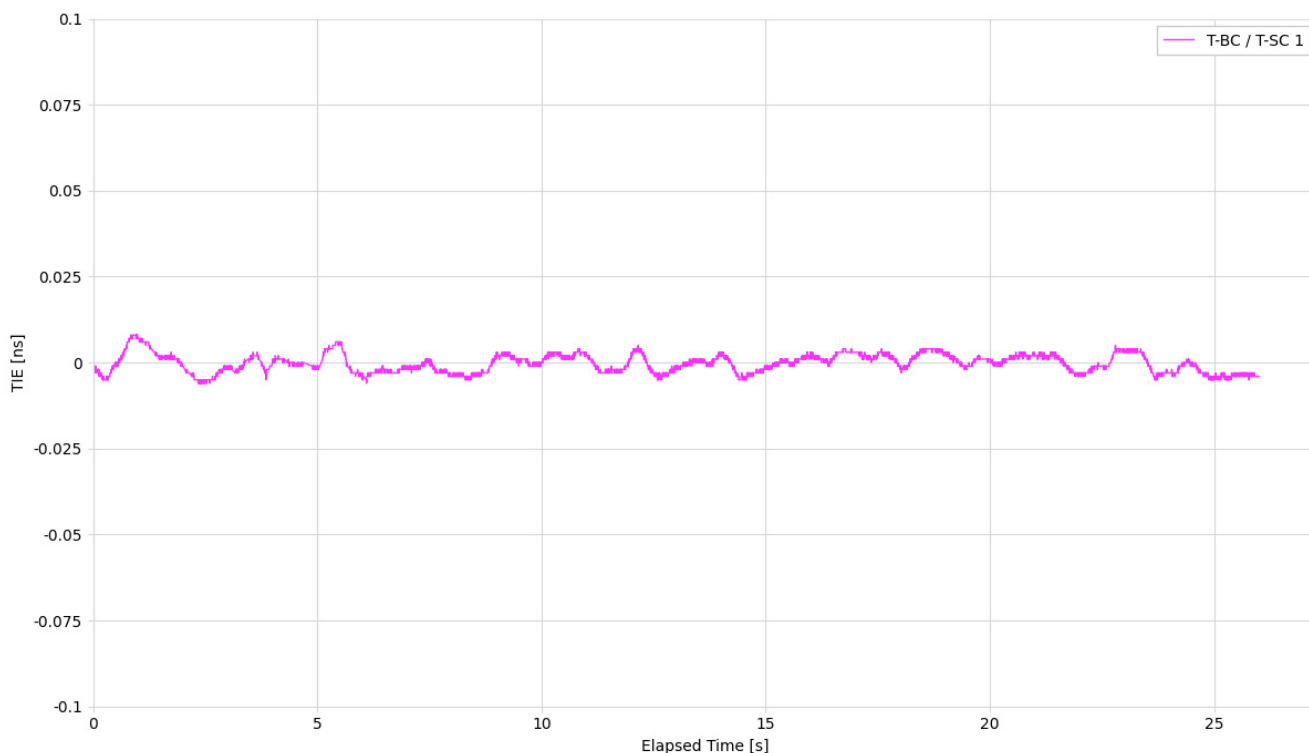

Figure 55. Short-term Phase Transient Response – G.8262.1 eEEC, 3Hz – TIE (no mask)

	T-BC / T-SC 1
Mean [ns]	-0.0
Min [ns]	-0.006
Max [ns]	0.008
Max-Min [ns]	0.014

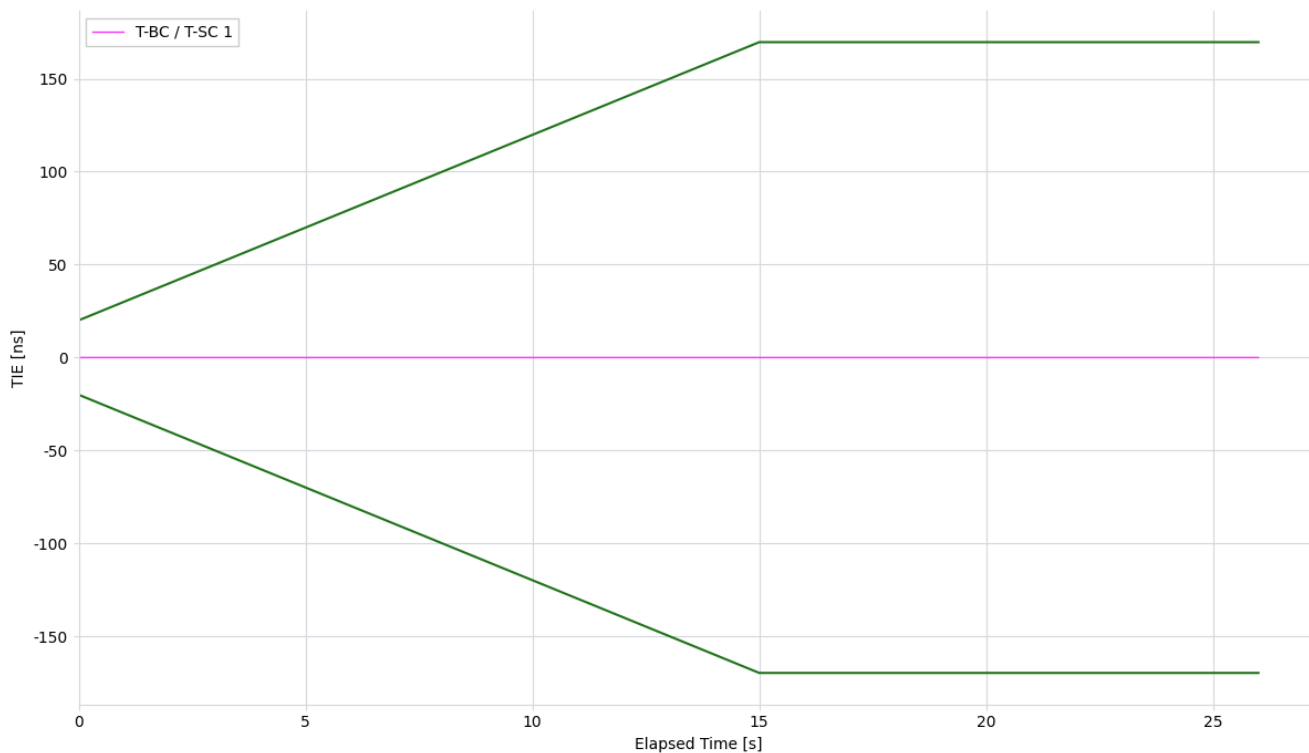

Figure 56. Short-term Phase Transient Response – G.8262.1 eEEC, 3Hz – TIE

	T-BC / T-SC 1
Mean [ns]	-0.0
Min [ns]	-0.006
Max [ns]	0.008
Max-Min [ns]	0.014

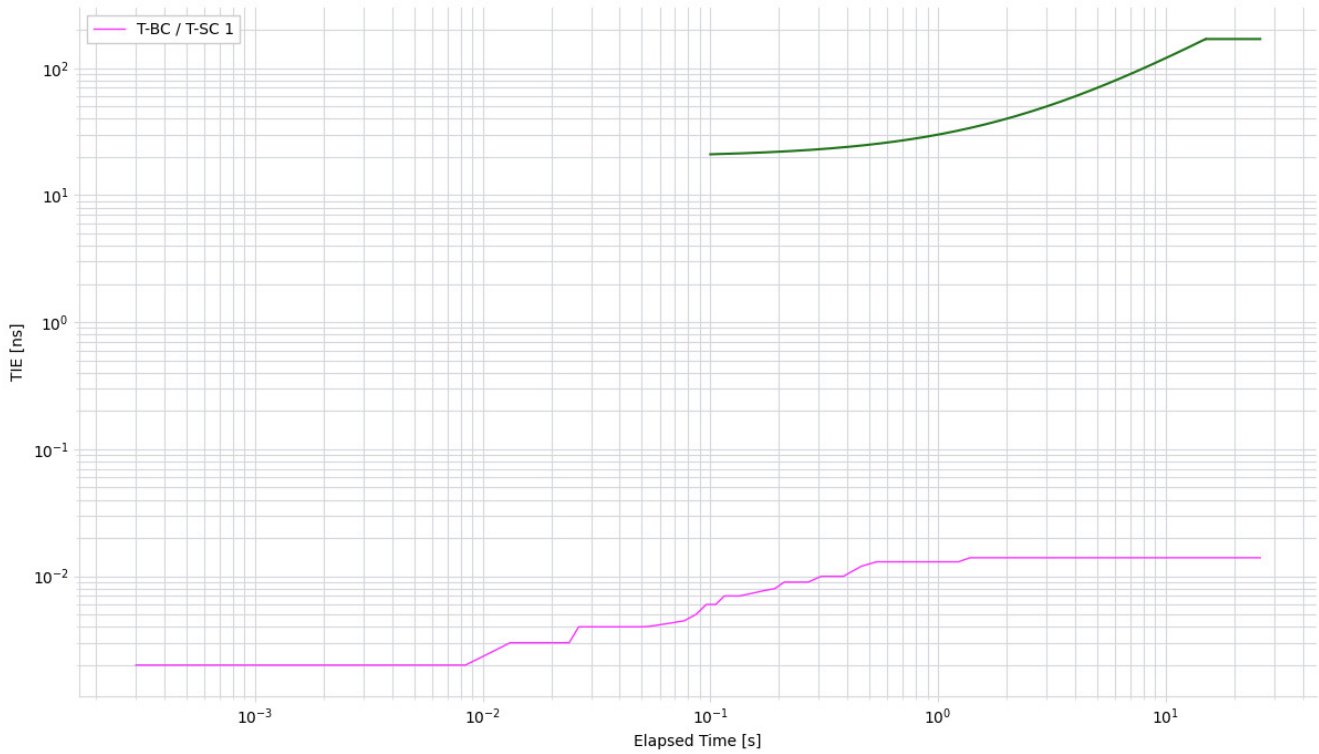

Figure 57. Short-term Phase Transient Response – G.8262.1 eEEC, 3Hz – MTIE

	T-BC / T-SC 1
Min [ns]	0.002
Max [ns]	0.014
Max-Min [ns]	0.012

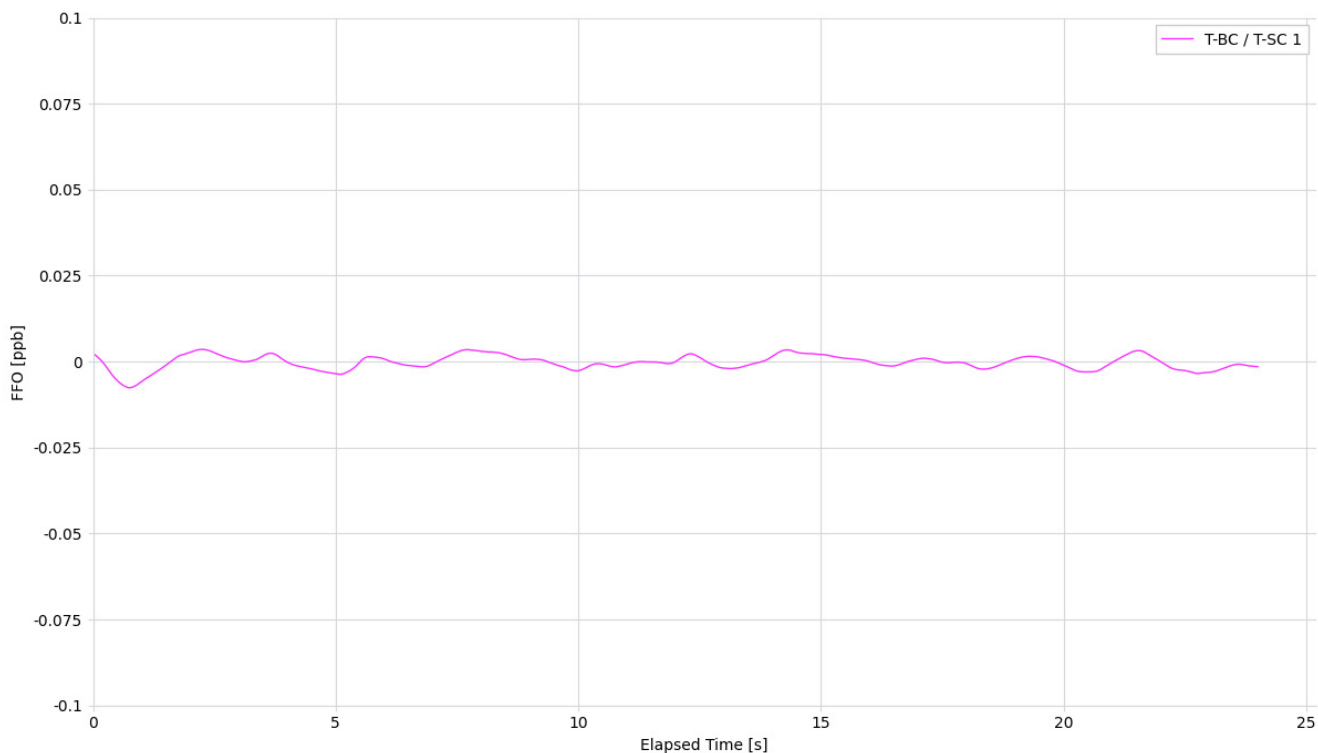

Figure 58. Short-term Phase Transient Response – G.8262.1 eEEC, 3Hz – FFO

	T-BC / T-SC 1
Mean [ppb]	-0.0
Min [ppb]	-0.008
Max [ppb]	0.004
Max-Min [ppb]	0.011

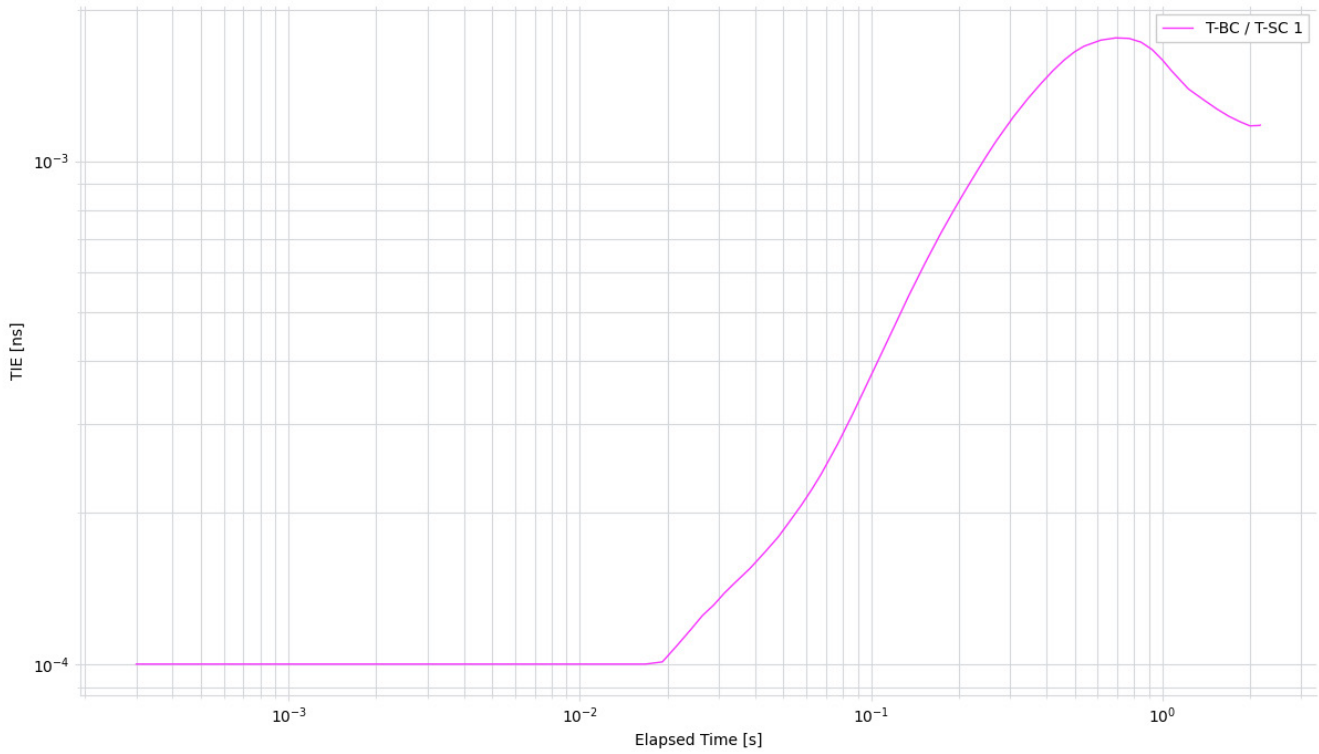

Figure 59. Short-term Phase Transient Response – G.8262.1 eEEC, 3Hz – TDEV

	T-BC / T-SC 1
Min [ns]	0.0
Max [ns]	0.002
Max-Min [ns]	0.002

7. Transient Tests with Hitless Switching Disabled

7.1 Phase Transient

Transient response requirement reflects the system response in situations where the input signal is affected by disturbances or transmission failures, resulting in phase transients at the synchronous EEC (Ethernet Equipment Clock) output. Short interruptions, switching between different reference clock signals, loss of reference etc., are categorized as transients, resulting in phase transients at the EEC output (see Figure 1 for the equipment configuration).

In this test, the reference clock inputs are provided on IN_A and IN_B from the Frequency Generator. The PLL is locked to the clock signal from IN_A for a period of time before producing a phase transient by turning off IN_A. The DPLL goes into holdover and tries to lock to any other qualified clocks. IN_B is simultaneously available from the Frequency Generator and the DPLL switches to this clock which is very close in phase alignment to the original clock. The output from the DUT is available on OUT_0 and the phase time error is captured using the Frequency Counter. The results of the given transient are plotted against the applicable standard profiles.

7.1.1. Phase Transient – G.8262 EEC Option 1, 1.2Hz

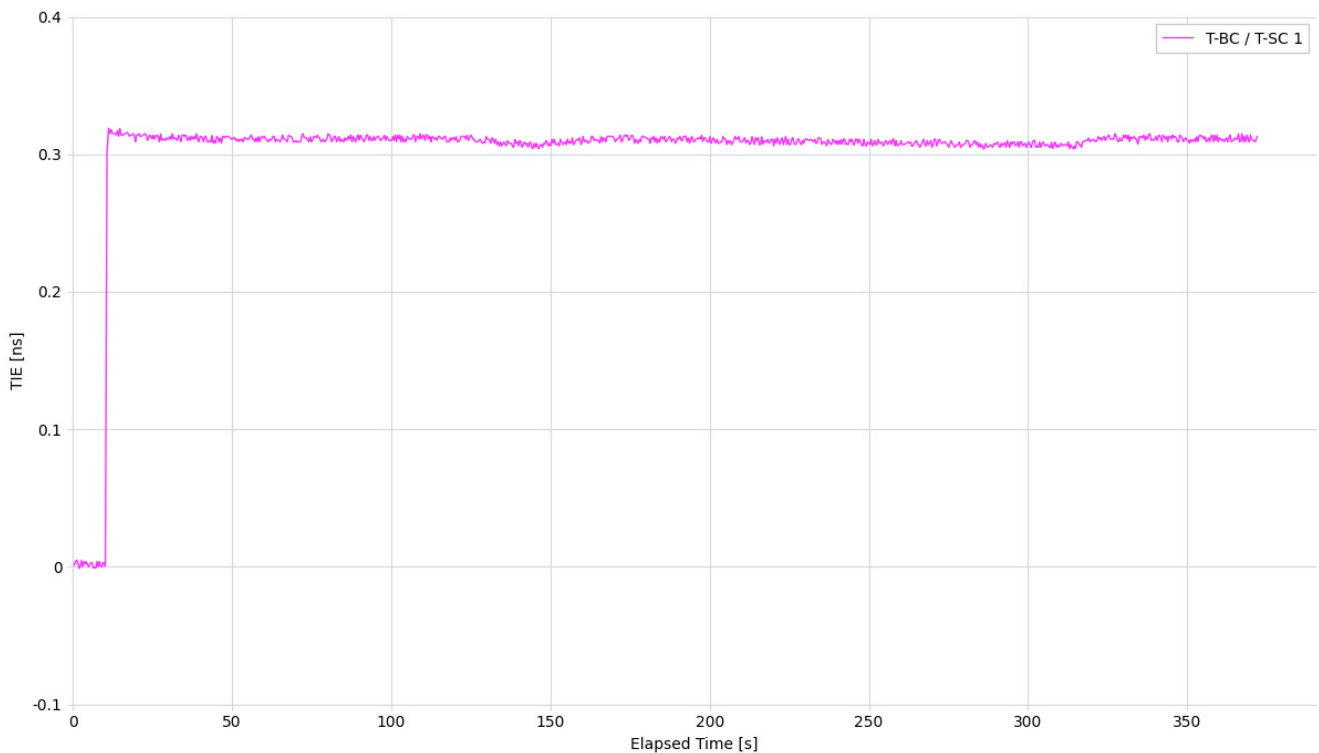

Figure 60. Phase Transient – G.8262 EEC Option 1, 1.2Hz – TIE (no mask)

	T-BC / T-SC 1
Mean [ns]	0.301
Min [ns]	-0.001
Max [ns]	0.319
Max-Min [ns]	0.32

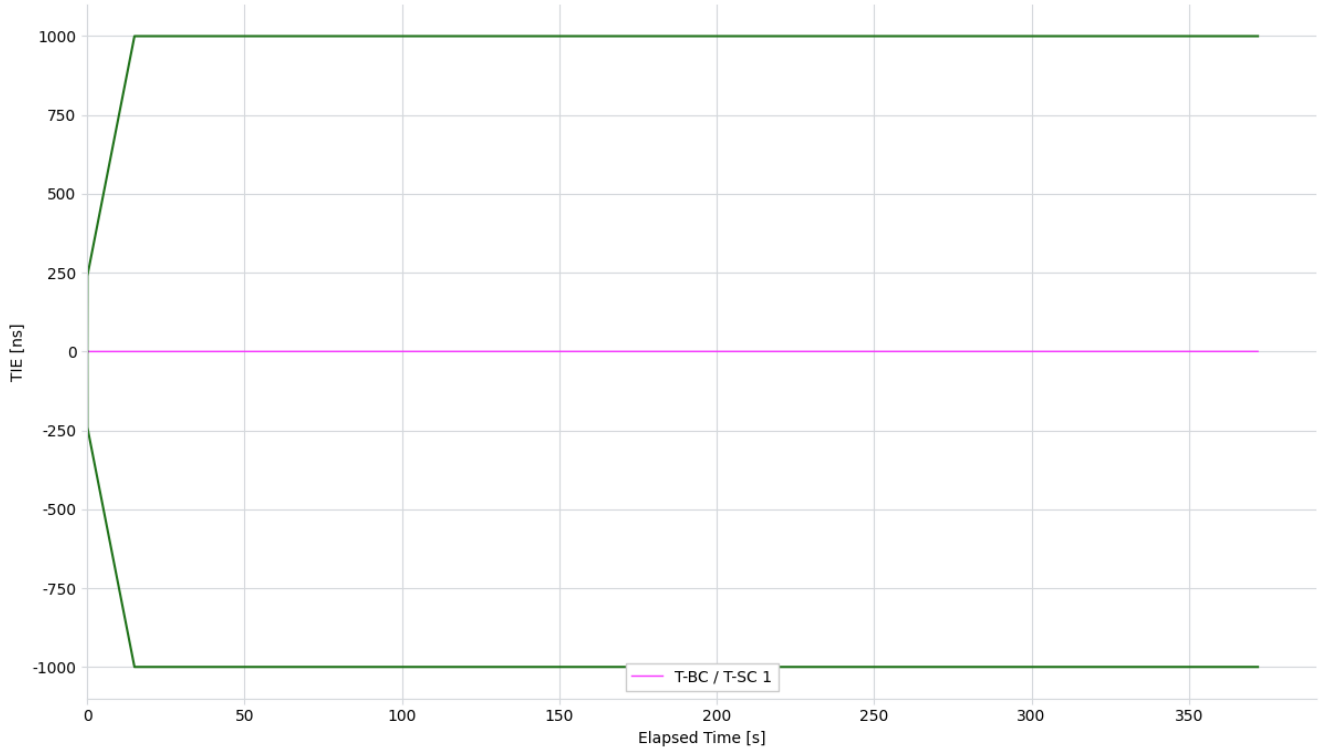

Figure 61. Phase Transient – G.8262 EEC Option 1, 1.2Hz – TIE

	T-BC / T-SC 1
Mean [ns]	0.301
Min [ns]	-0.001
Max [ns]	0.319
Max-Min [ns]	0.32

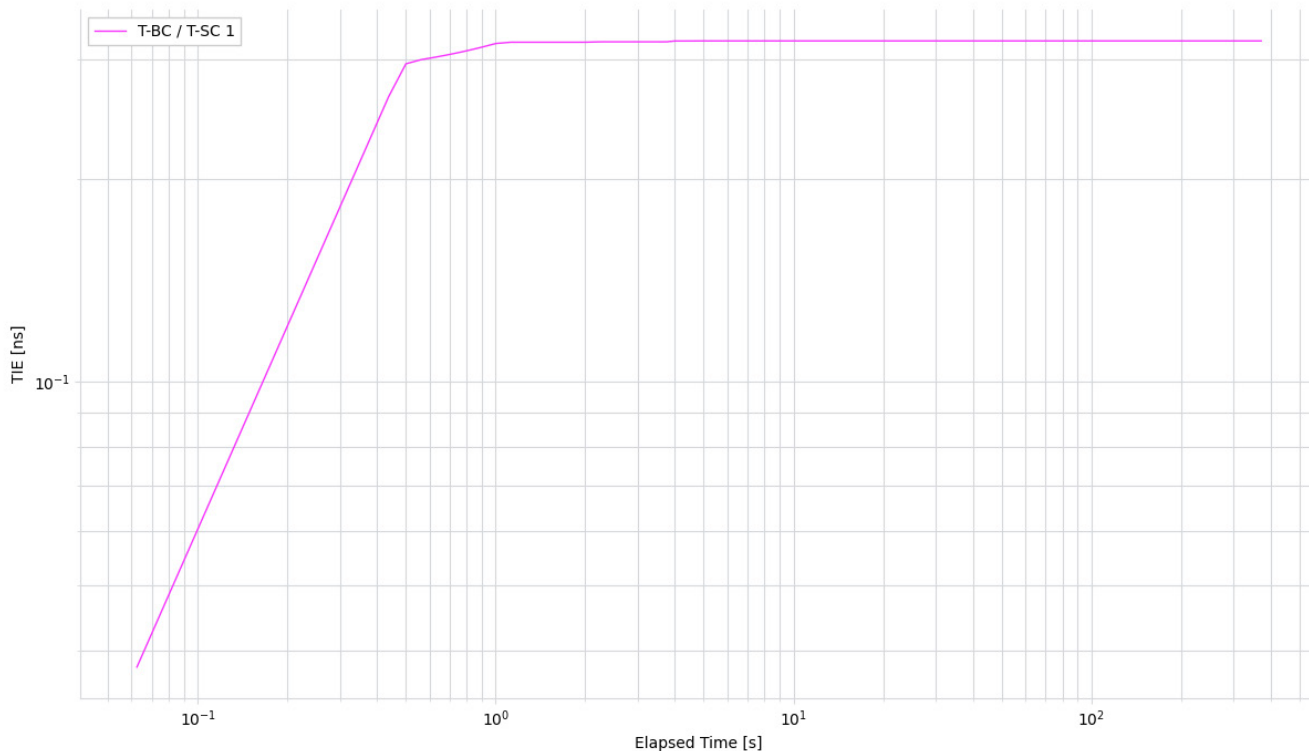

Figure 62. Phase Transient – G.8262 EEC Option 1, 1.2Hz – MTIE

	T-BC / T-SC 1
Min [ns]	0.038
Max [ns]	0.32
Max-Min [ns]	0.282

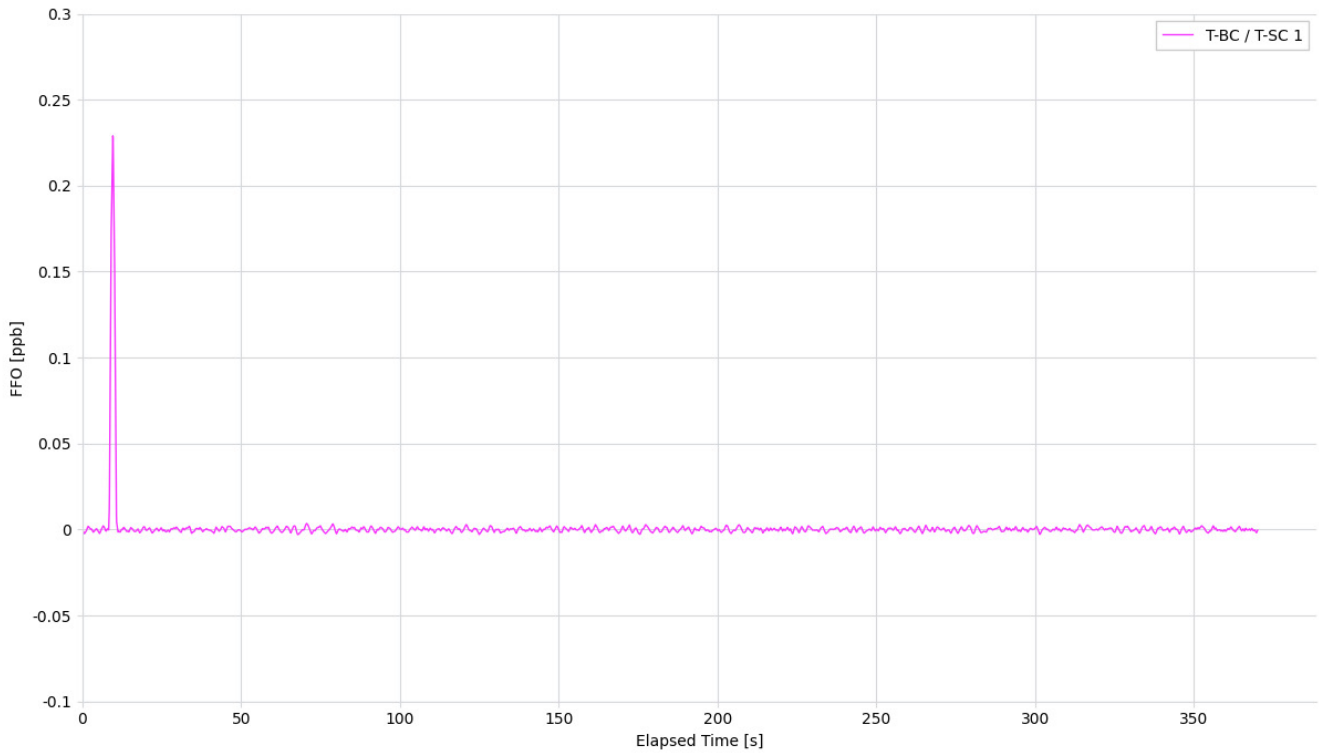

Figure 63. Phase Transient – G.8262 EEC Option 1, 1.2Hz – FFO

	T-BC / T-SC 1
Mean [ppb]	0.001
Min [ppb]	-0.003
Max [ppb]	0.229
Max-Min [ppb]	0.232

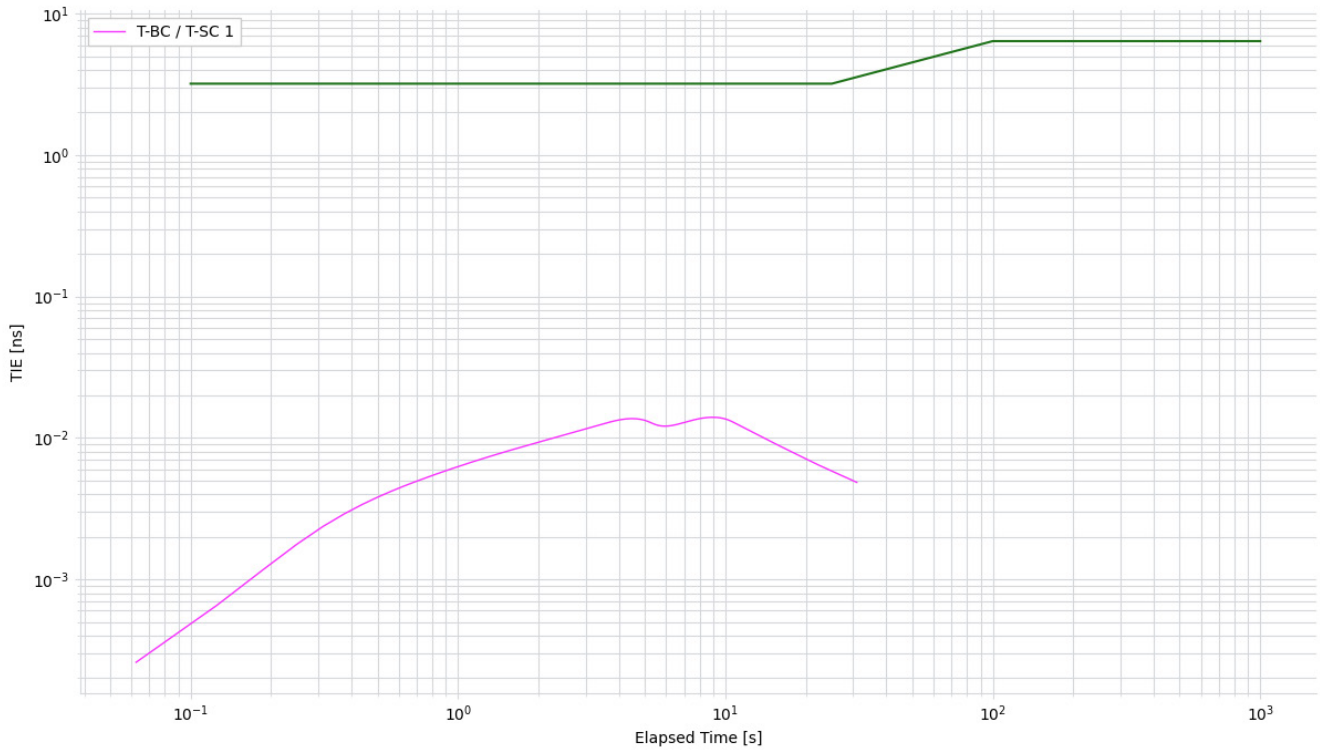

Figure 64. Phase Transient – G.8262 EEC Option 1, 1.2Hz – TDEV

	T-BC / T-SC 1
Min [ns]	0.0
Max [ns]	0.014
Max-Min [ns]	0.014

7.1.2. Phase Transient – G.8262 EEC Option 1, 10Hz

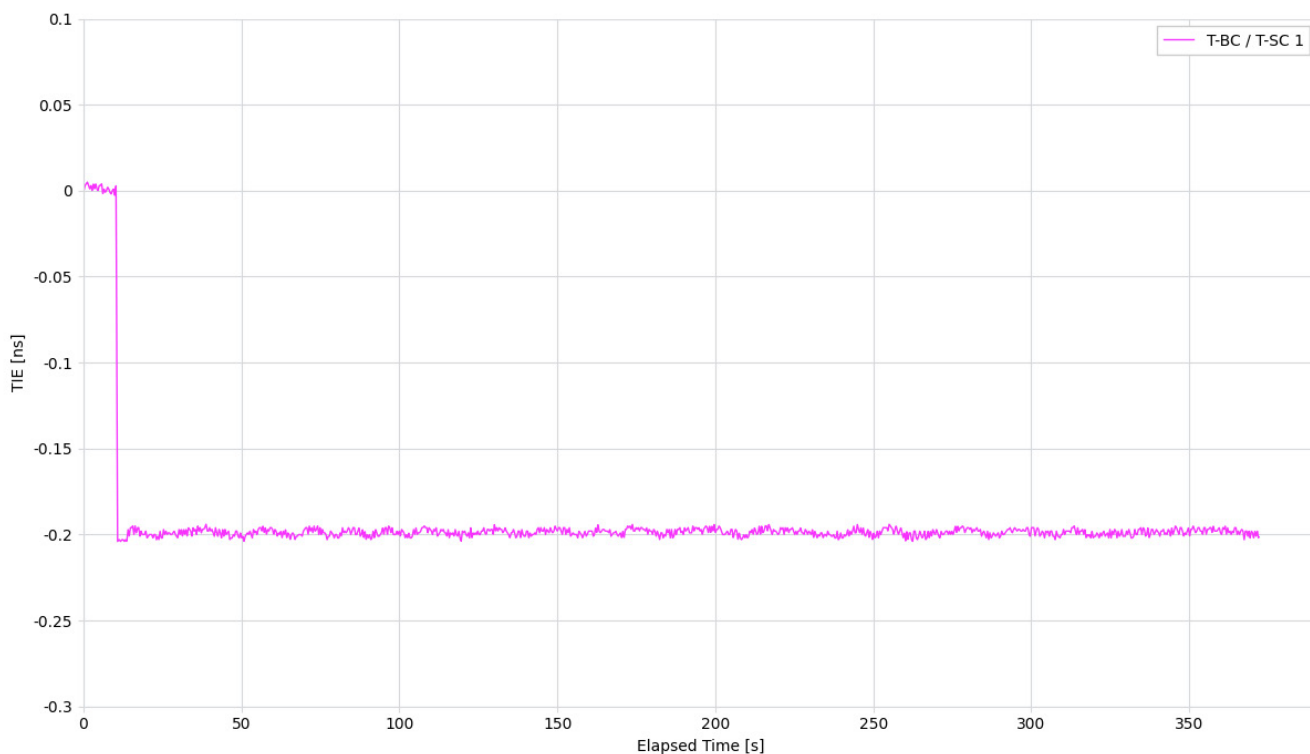

Figure 65. Phase Transient – G.8262 EEC Option 1, 10Hz – TIE (no mask)

	T-BC / T-SC 1
Mean [ns]	-0.193
Min [ns]	-0.204
Max [ns]	0.005
Max-Min [ns]	0.209

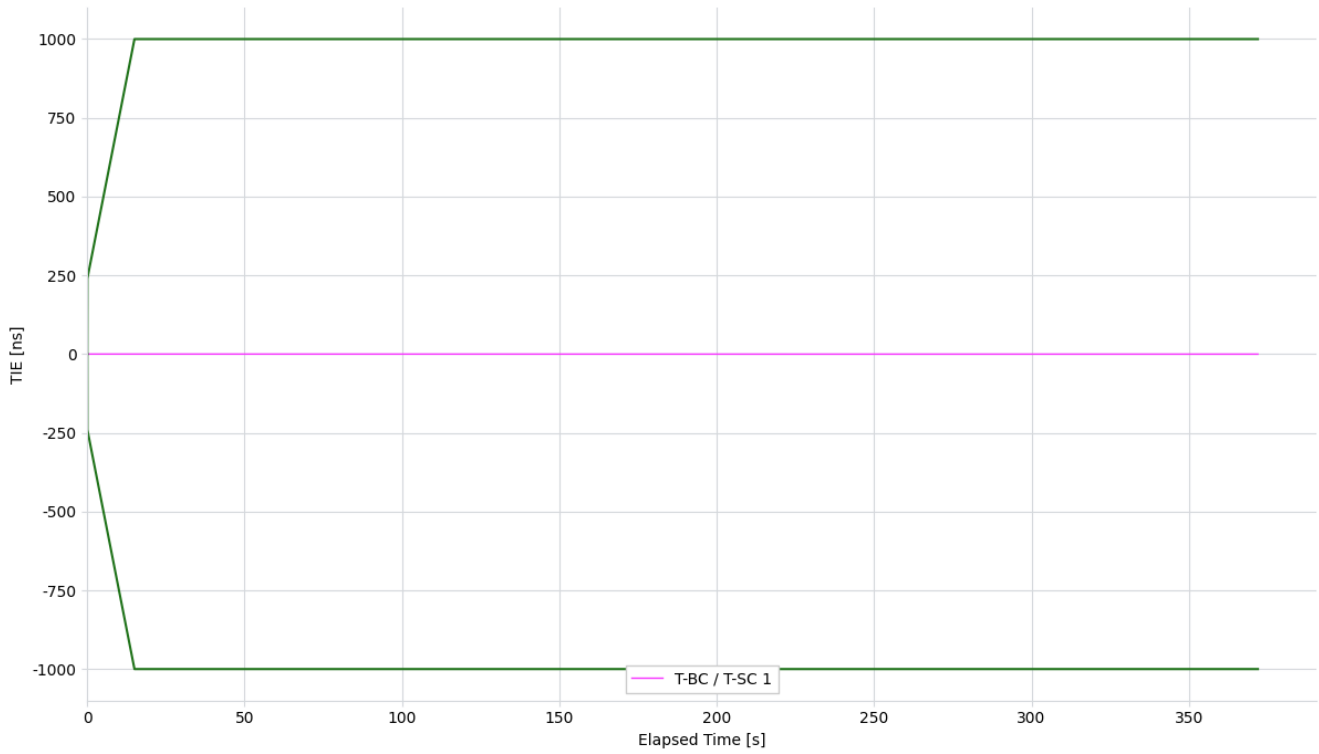

Figure 66. Phase Transient – G.8262 EEC Option 1, 10Hz – TIE

	T-BC / T-SC 1
Mean [ns]	-0.193
Min [ns]	-0.204
Max [ns]	0.005
Max-Min [ns]	0.209

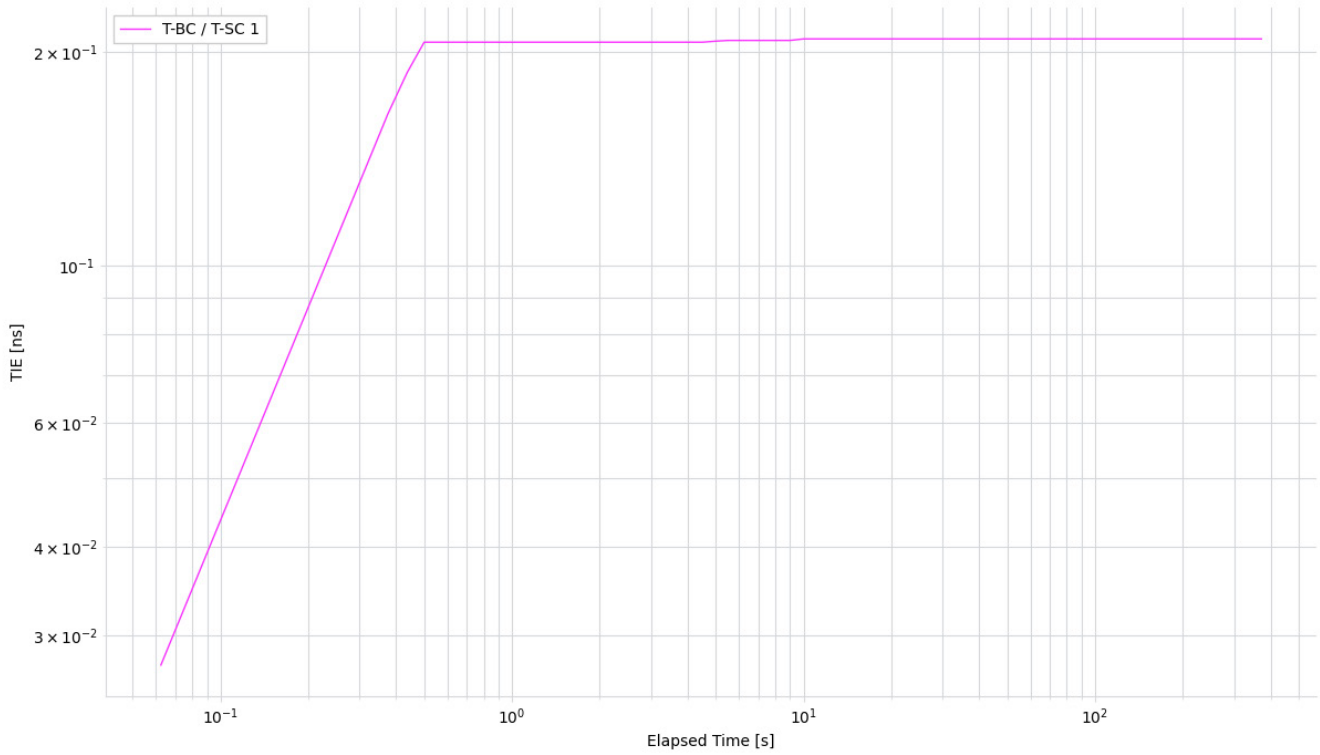

Figure 67. Phase Transient – G.8262 EEC Option 1, 10Hz – MTIE

	T-BC / T-SC 1
Min [ns]	0.027
Max [ns]	0.209
Max-Min [ns]	0.182

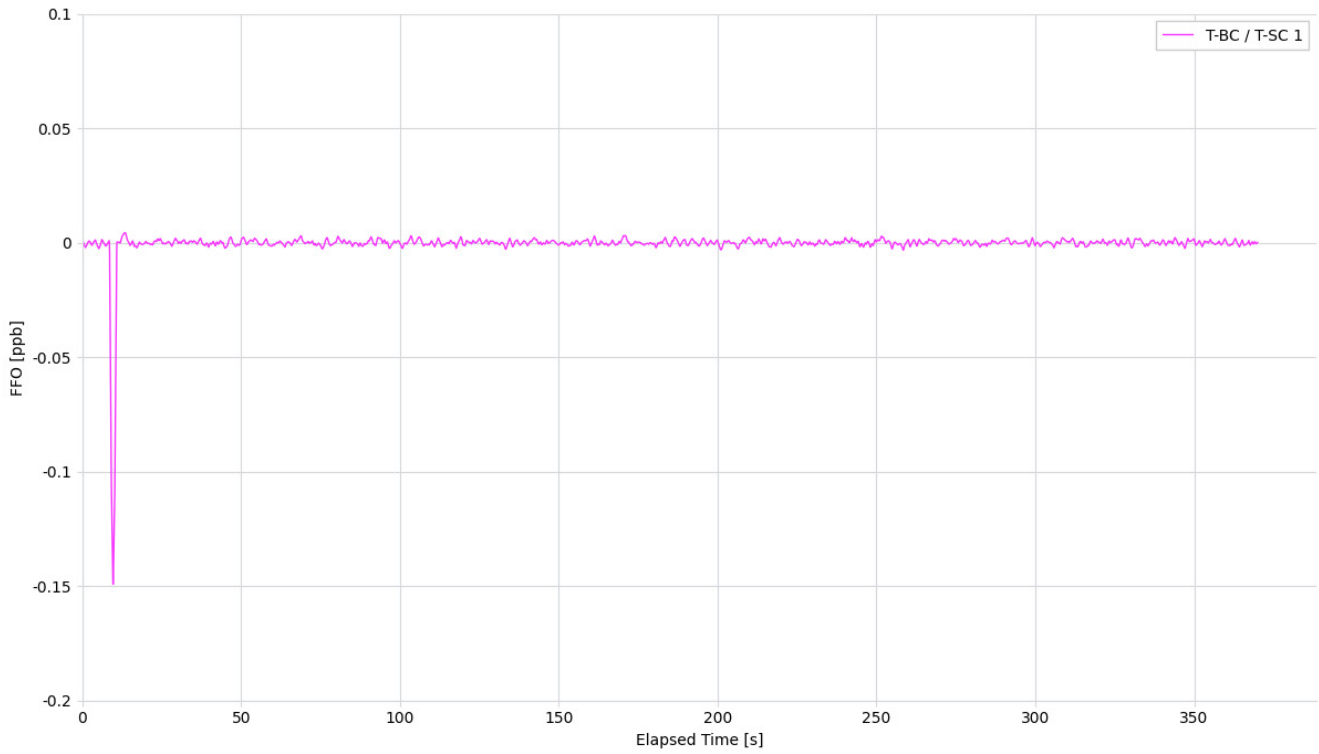

Figure 68. Phase Transient – G.8262 EEC Option 1, 10Hz – FFO

	T-BC / T-SC 1
Mean [ppb]	-0.001
Min [ppb]	-0.149
Max [ppb]	0.004
Max-Min [ppb]	0.154

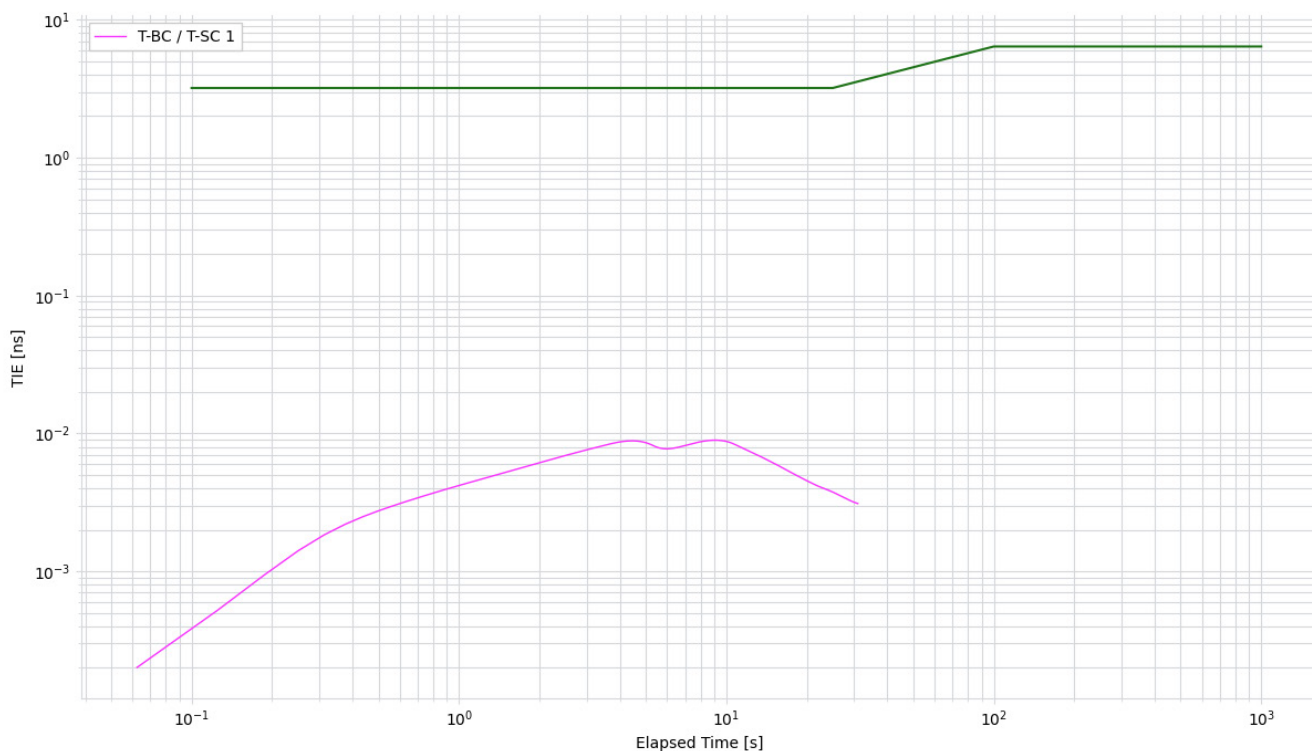

Figure 69. Phase Transient – G.8262 EEC Option 1, 10Hz – TDEV

	T-BC / T-SC 1
Min [ns]	0.0
Max [ns]	0.009
Max-Min [ns]	0.009

7.1.3. Phase Transient – G.8262 EEC Option 2, 0.1Hz

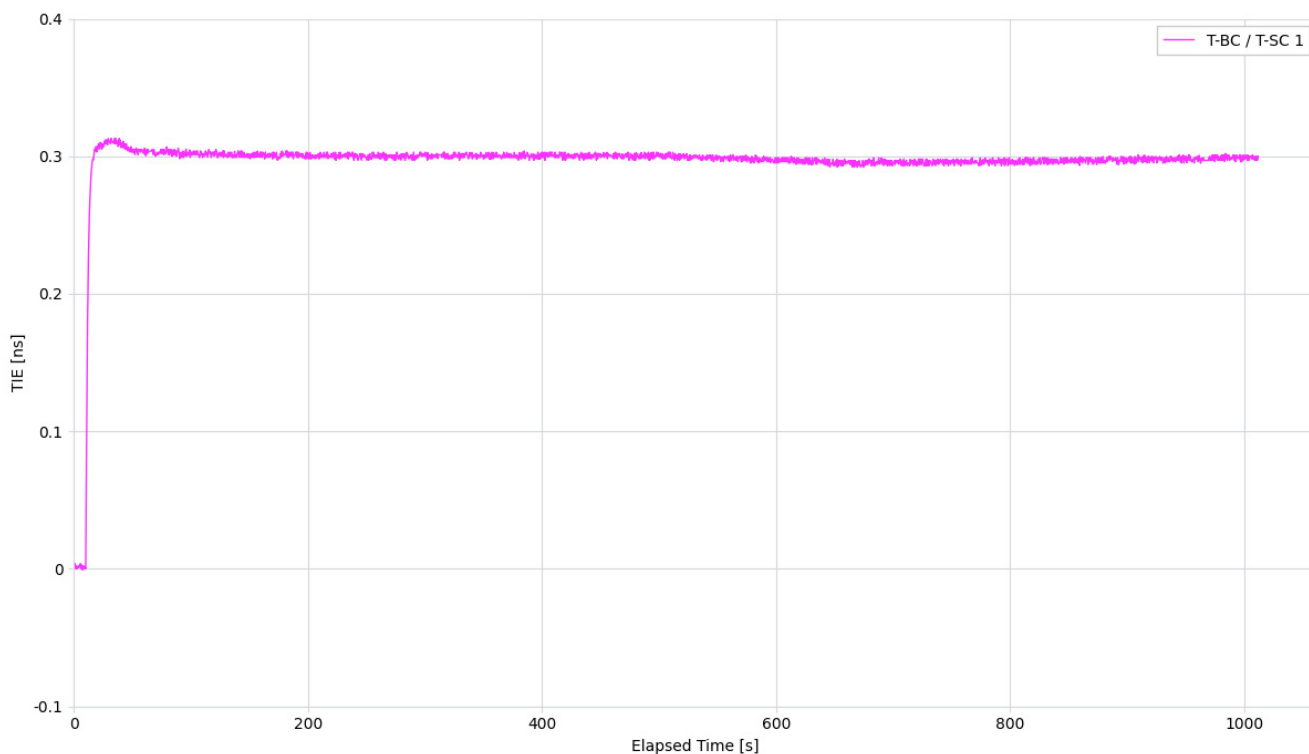

Figure 70. Phase Transient – G.8262 EEC Option 2, 0.1Hz – TIE

	T-BC / T-SC 1
Mean [ns]	0.296
Min [ns]	-0.001
Max [ns]	0.313
Max-Min [ns]	0.314

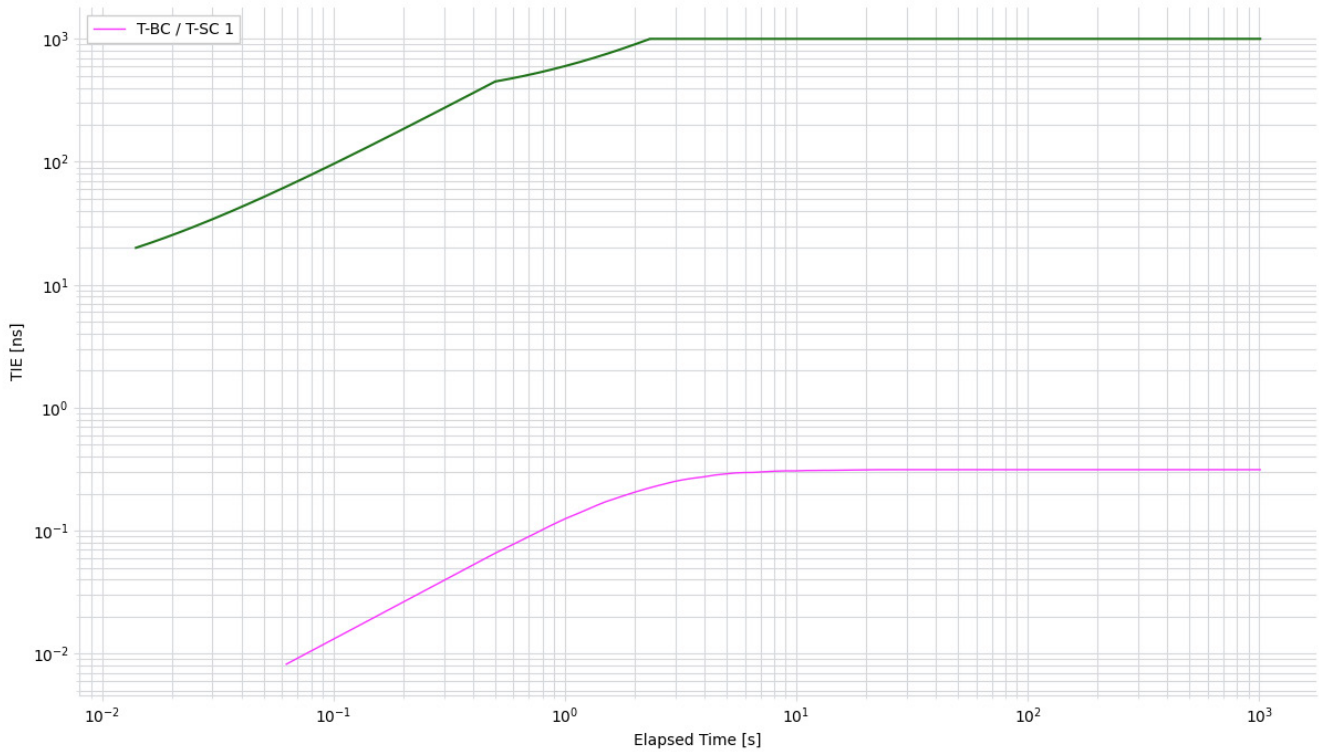

Figure 71. Phase Transient – G.8262 EEC Option 2, 0.1Hz – MTIE

	T-BC / T-SC 1
Min [ns]	0.008
Max [ns]	0.314
Max-Min [ns]	0.306

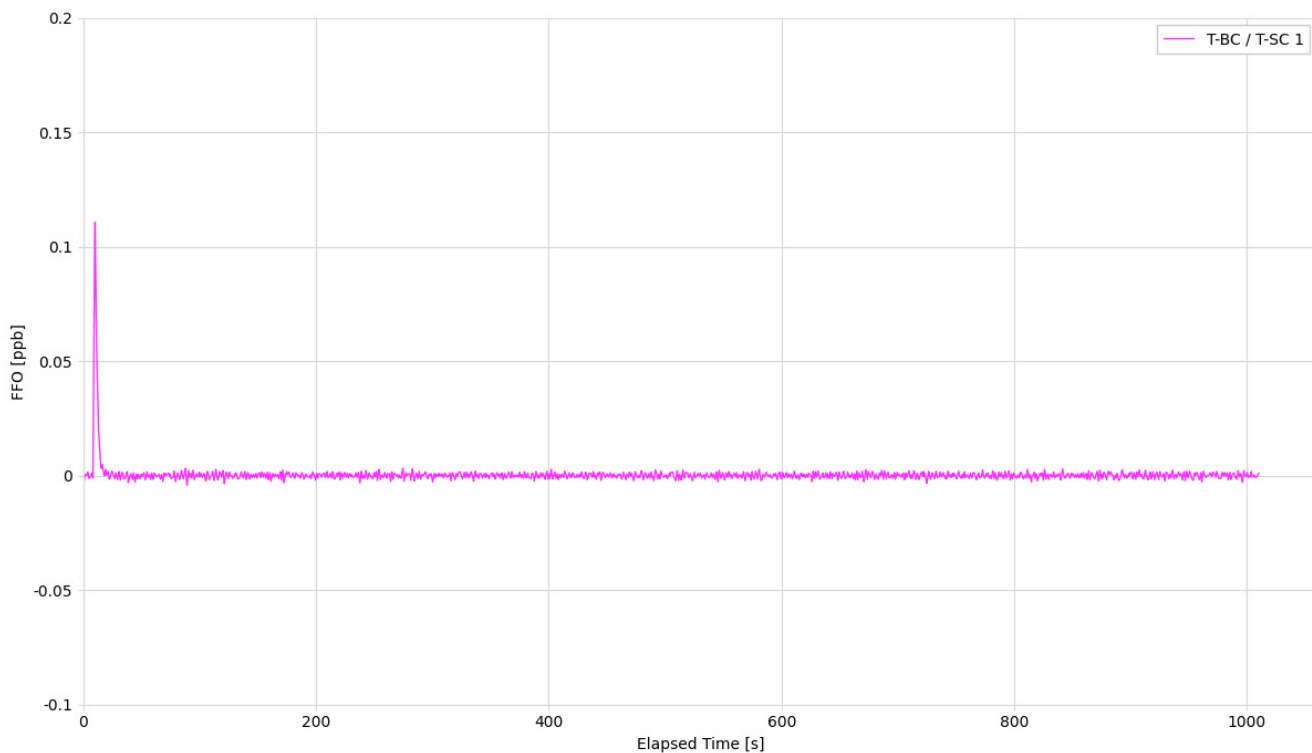

Figure 72. Phase Transient – G.8262 EEC Option 2, 0.1Hz – FFO

	T-BC / T-SC 1
Mean [ppb]	0.0
Min [ppb]	-0.004
Max [ppb]	0.111
Max-Min [ppb]	0.115

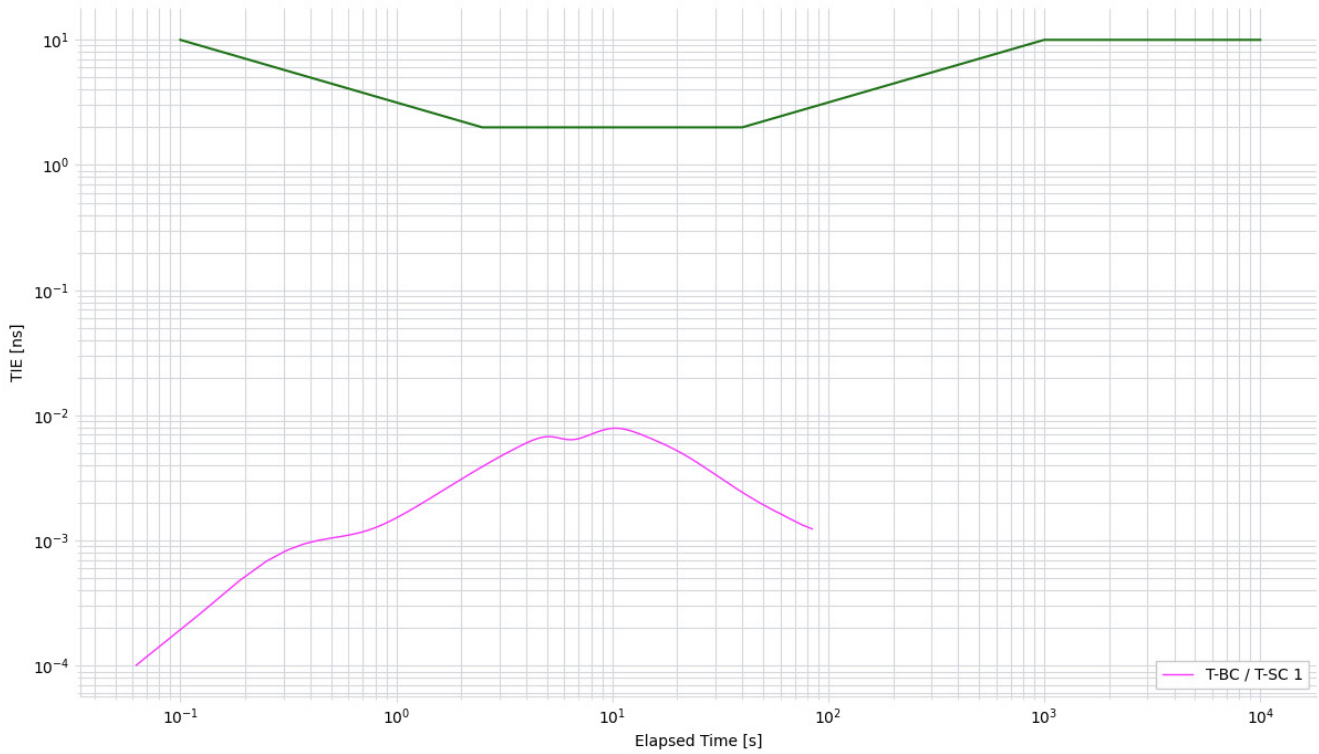

Figure 73. Phase Transient – G.8262 EEC Option 2, 0.1Hz – TDEV

	T-BC / T-SC 1
Min [ns]	0.0
Max [ns]	0.008
Max-Min [ns]	0.008

7.1.4. Phase Transient – G.8262.1 eEEC, 3Hz

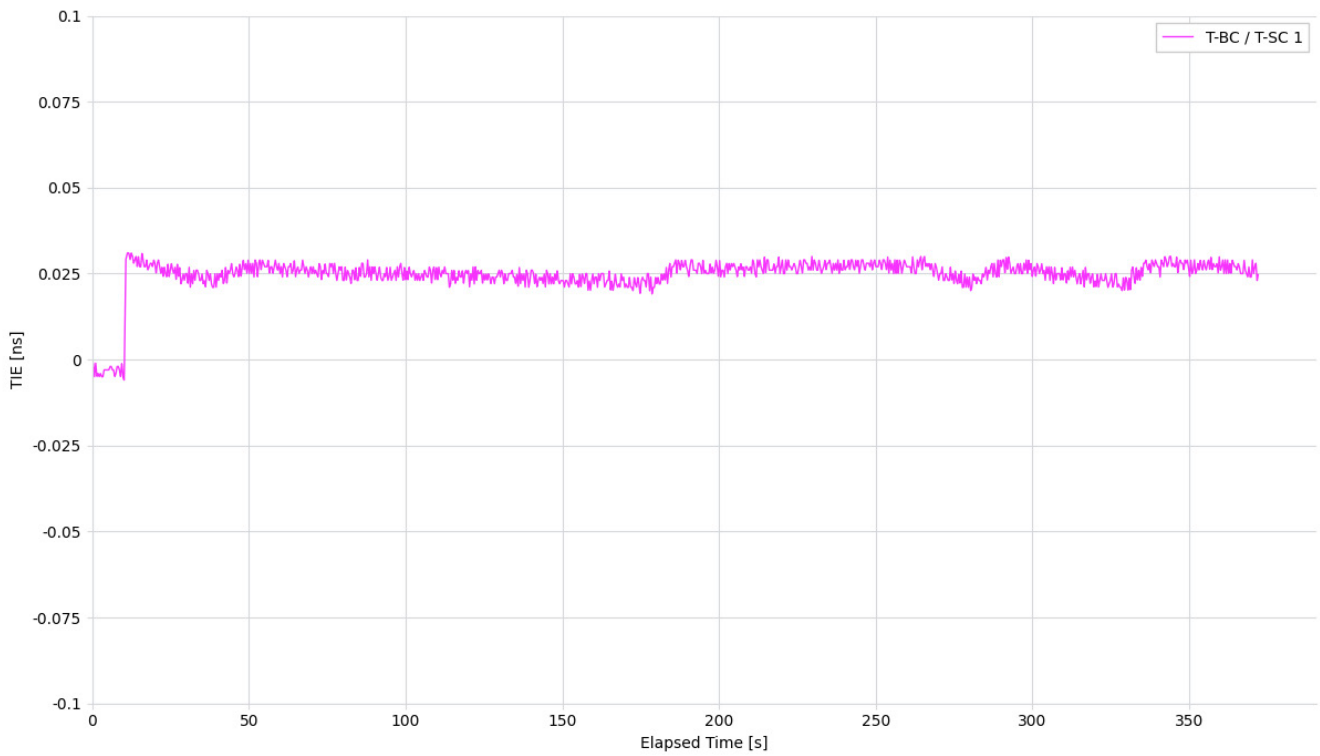

Figure 74. Phase Transient – G.8262.1 eEEC, 3Hz – TIE (no mask)

	T-BC / T-SC 1
Mean [ns]	0.025
Min [ns]	-0.006
Max [ns]	0.031
Max-Min [ns]	0.037

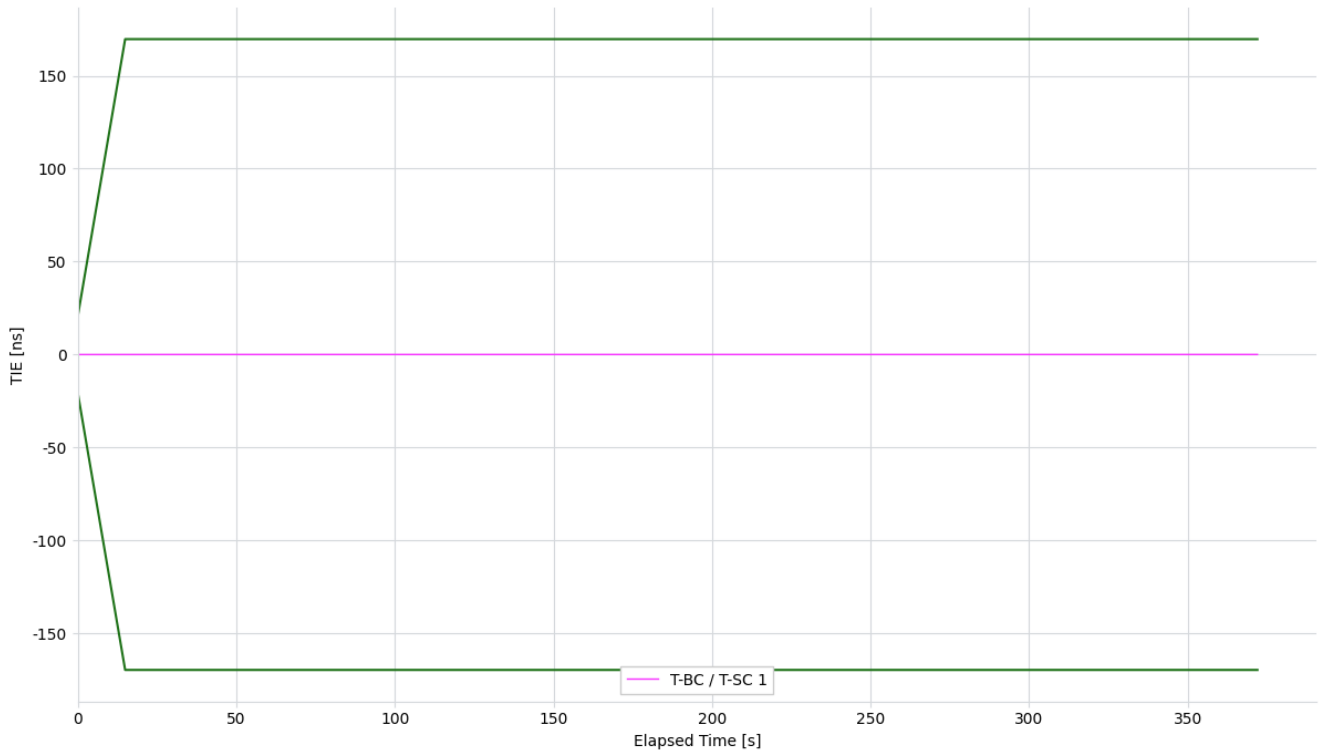

Figure 75. Phase Transient – G.8262.1 eEEC, 3Hz – TIE

	T-BC / T-SC 1
Mean [ns]	0.025
Min [ns]	-0.006
Max [ns]	0.031
Max-Min [ns]	0.037

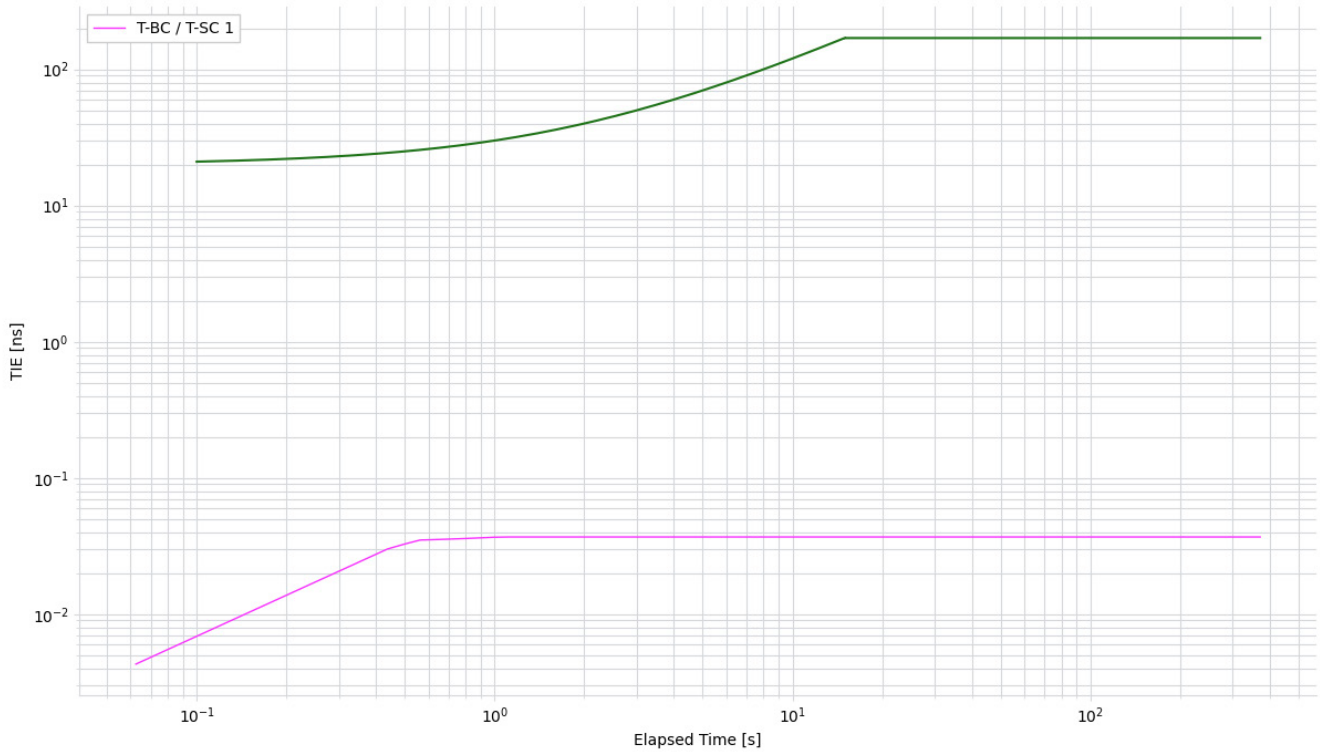

Figure 76. Phase Transient – G.8262.1 eEEC, 3Hz – MTIE

	T-BC / T-SC 1
Min [ns]	0.004
Max [ns]	0.037
Max-Min [ns]	0.033

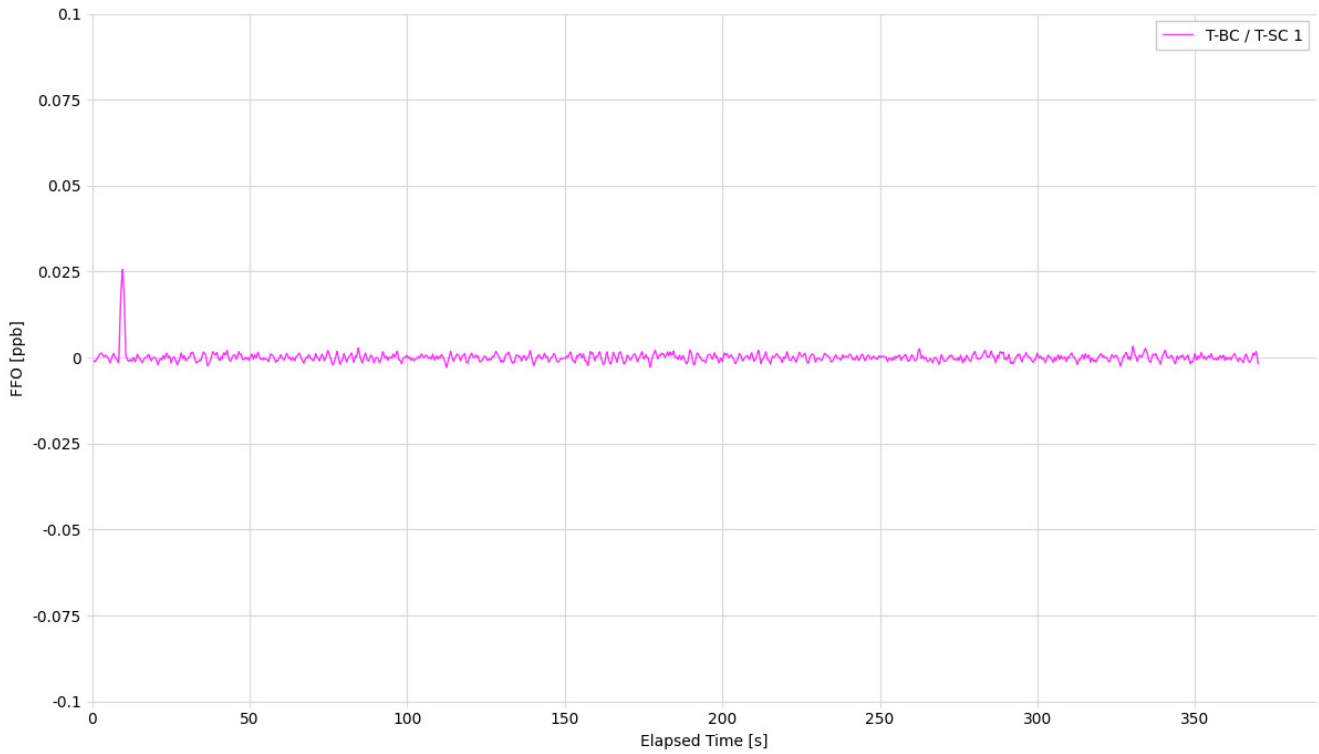

Figure 77. Phase Transient – G.8262.1 eEEC, 3Hz – FFO

	T-BC / T-SC 1
Mean [ppb]	0.0
Min [ppb]	-0.003
Max [ppb]	0.026
Max-Min [ppb]	0.028

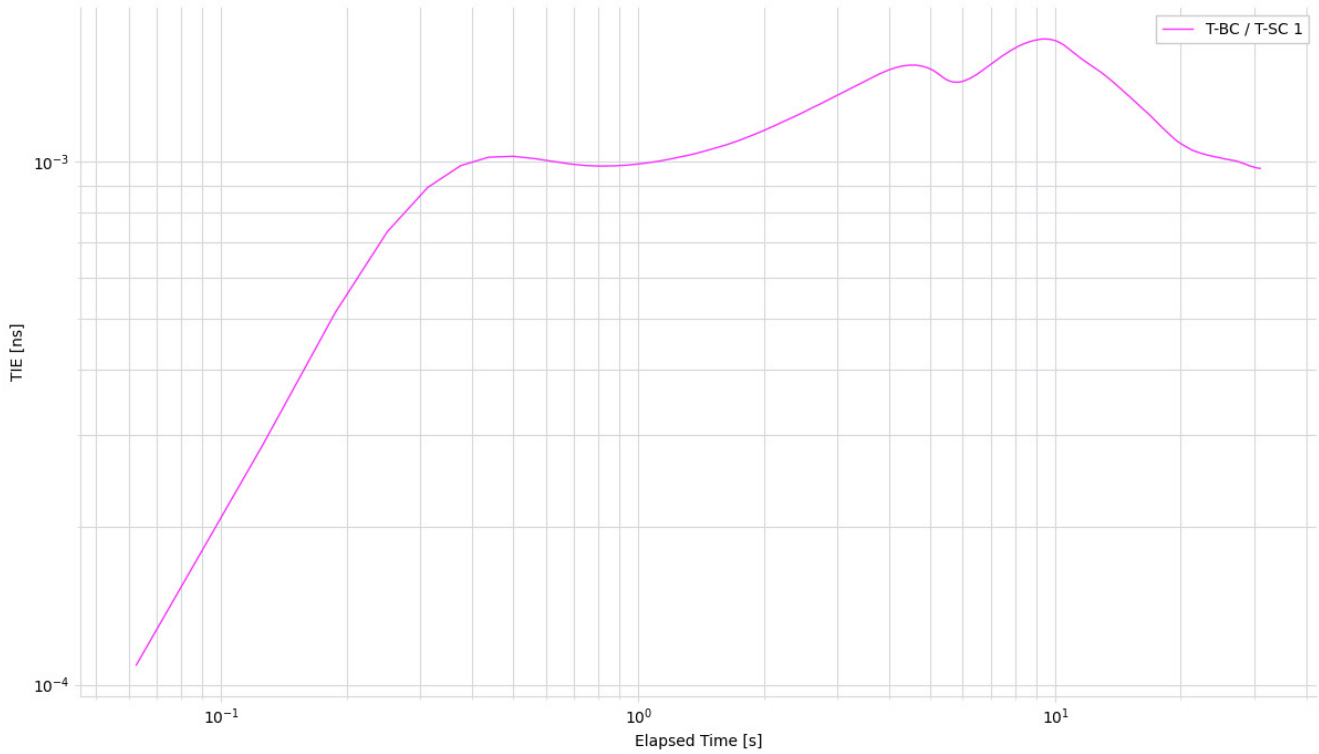

Figure 78. Phase Transient – G.8262.1 eEEC, 3Hz – TDEV

	T-BC / T-SC 1
Min [ns]	0.0
Max [ns]	0.002
Max-Min [ns]	0.002

7.2 Phase Discontinuity

Phase discontinuity requirement reflects the performance of the DUT in cases when the (selected) input reference is lost due to a failure in the reference path and a second reference input signal, traceable to the same reference clock, is available simultaneously or shortly after the detection of the failure (see Figure 1 for the equipment configuration).

The test was carried out by providing reference clock inputs on IN_A and IN_B from the Frequency Generator, which are 180° out of phase from each other. The PLL is locked to the clock signal from IN_A for a given period of time before producing a phase transient by turning off the signal to IN_A from the waveform generator, while the signal at IN_B is simultaneously available to the DUT. The DPLL will try to lock to the reference signal on IN_B. The output from the DUT is available on OUT_0 and the phase time error is captured using the Frequency Counter. The results of the given transient are plotted against the applicable standard profiles.

7.2.1. Phase Discontinuity – G.8262 EEC Option 1, 1.2Hz

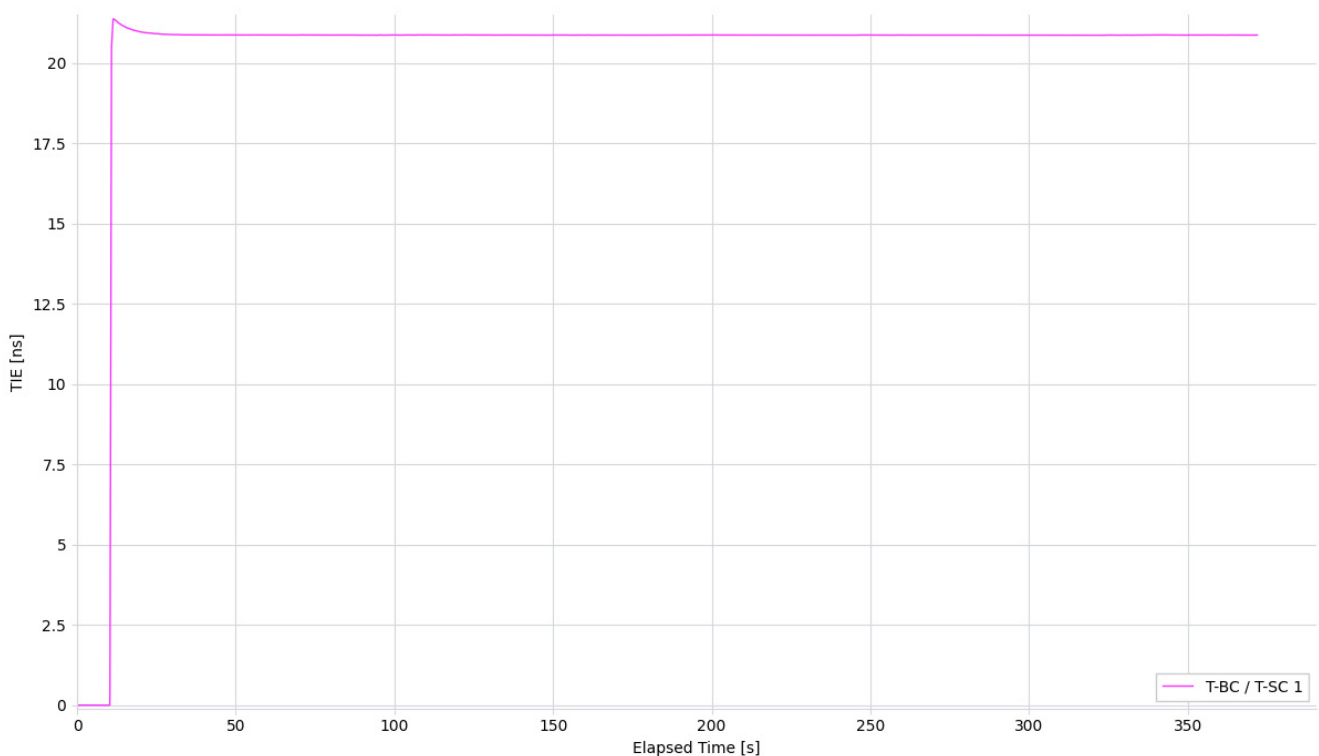

Figure 79. Phase Discontinuity – G.8262 EEC Option 1, 1.2Hz

	T-BC / T-SC 1
Mean [ns]	20.275
Min [ns]	0.001
Max [ns]	21.363
Max-Min [ns]	21.362

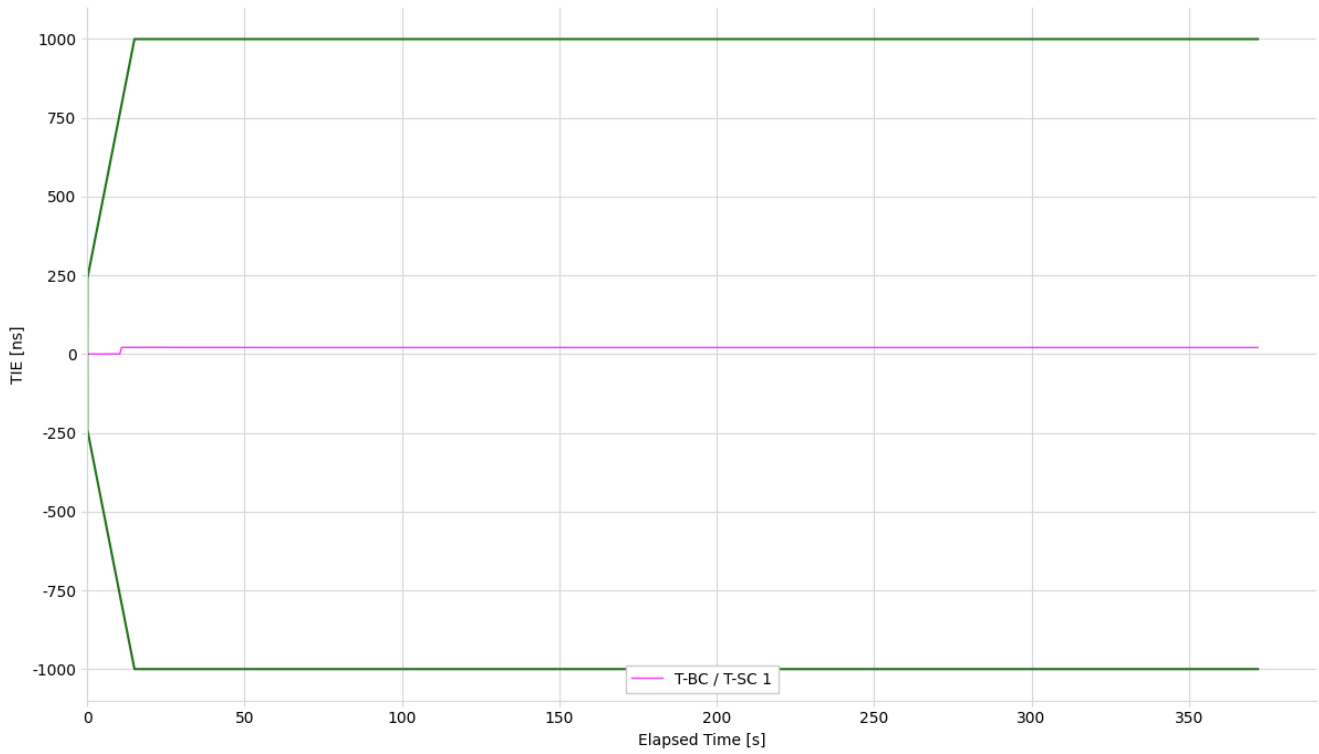

Figure 80. Phase Discontinuity – G.8262 EEC Option 1, 1.2Hz – TIE

	T-BC / T-SC 1
Mean [ns]	20.275
Min [ns]	0.001
Max [ns]	21.363
Max-Min [ns]	21.362

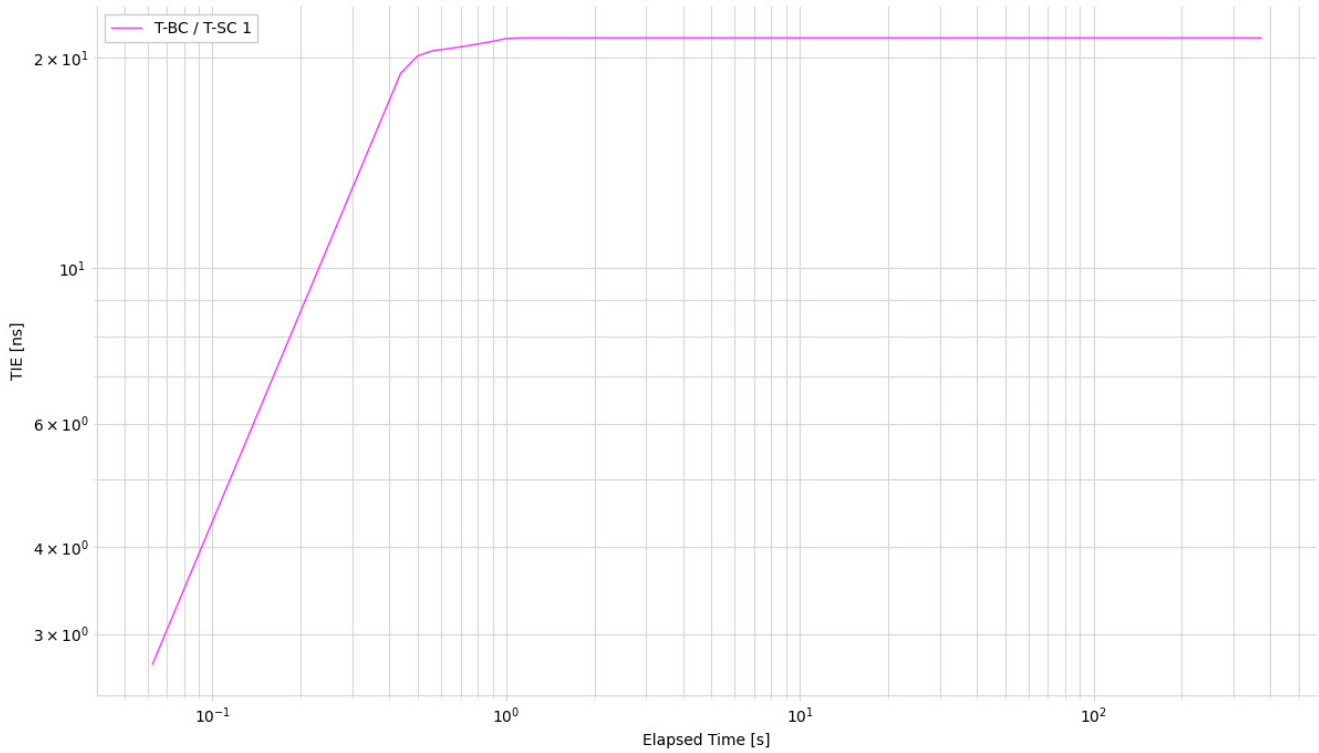

Figure 81. Phase Discontinuity – G.8262 EEC Option 1, 1.2Hz – MTIE

	T-BC / T-SC 1
Min [ns]	2.717
Max [ns]	21.362
Max-Min [ns]	18.645

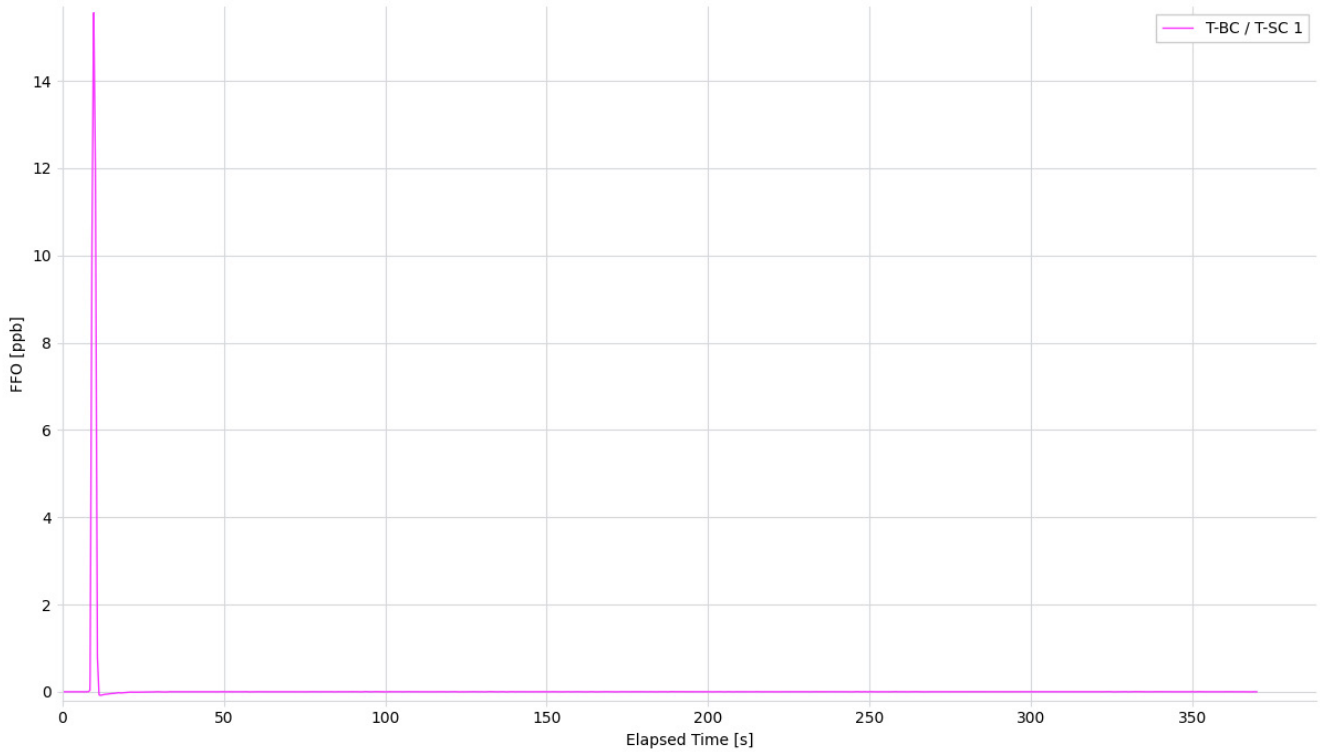

Figure 82. Phase Discontinuity – G.8262 EEC Option 1, 1.2Hz – FFO

	T-BC / T-SC 1
Mean [ppb]	0.056
Min [ppb]	-0.082
Max [ppb]	15.558
Max-Min [ppb]	15.639

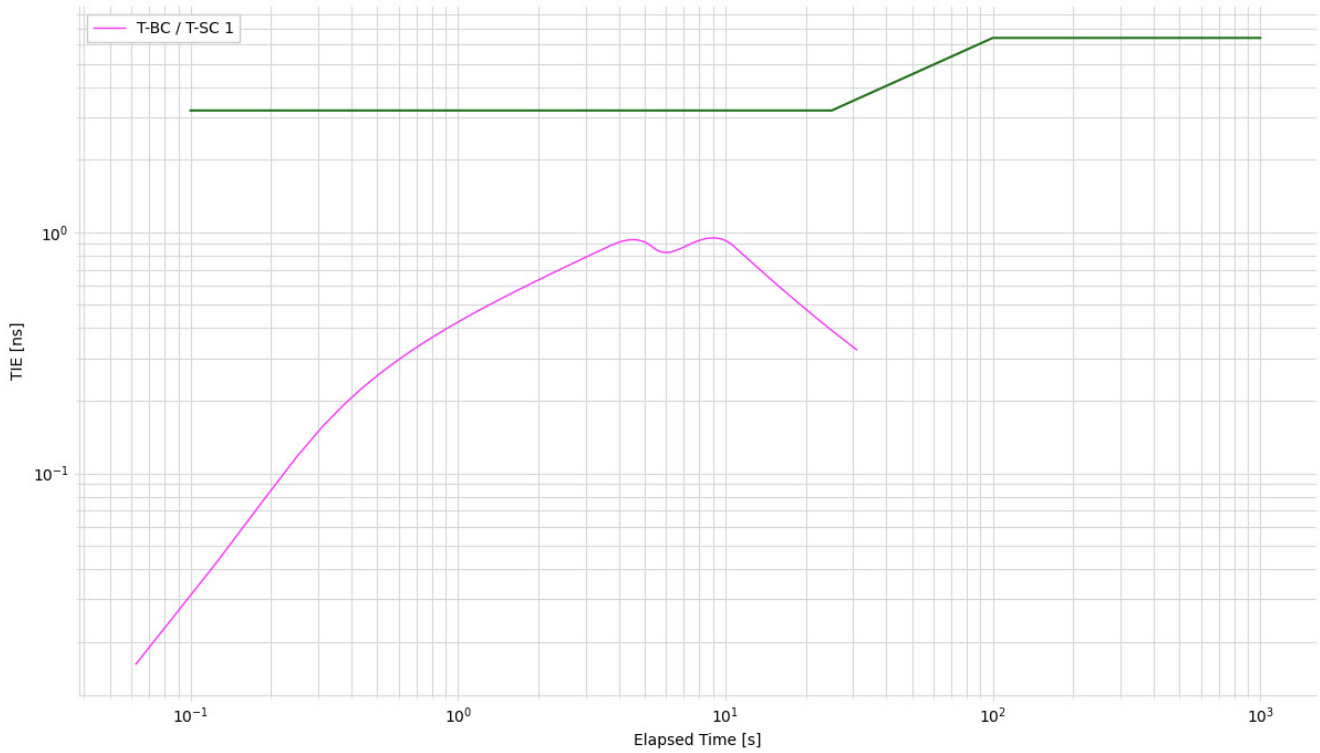

Figure 83. Phase Discontinuity – G.8262 EEC Option 1, 1.2Hz – TDEV

	T-BC / T-SC 1
Min [ns]	0.016
Max [ns]	0.947
Max-Min [ns]	0.931

7.2.2. Phase Discontinuity – G.8262 EEC Option 1, 10Hz

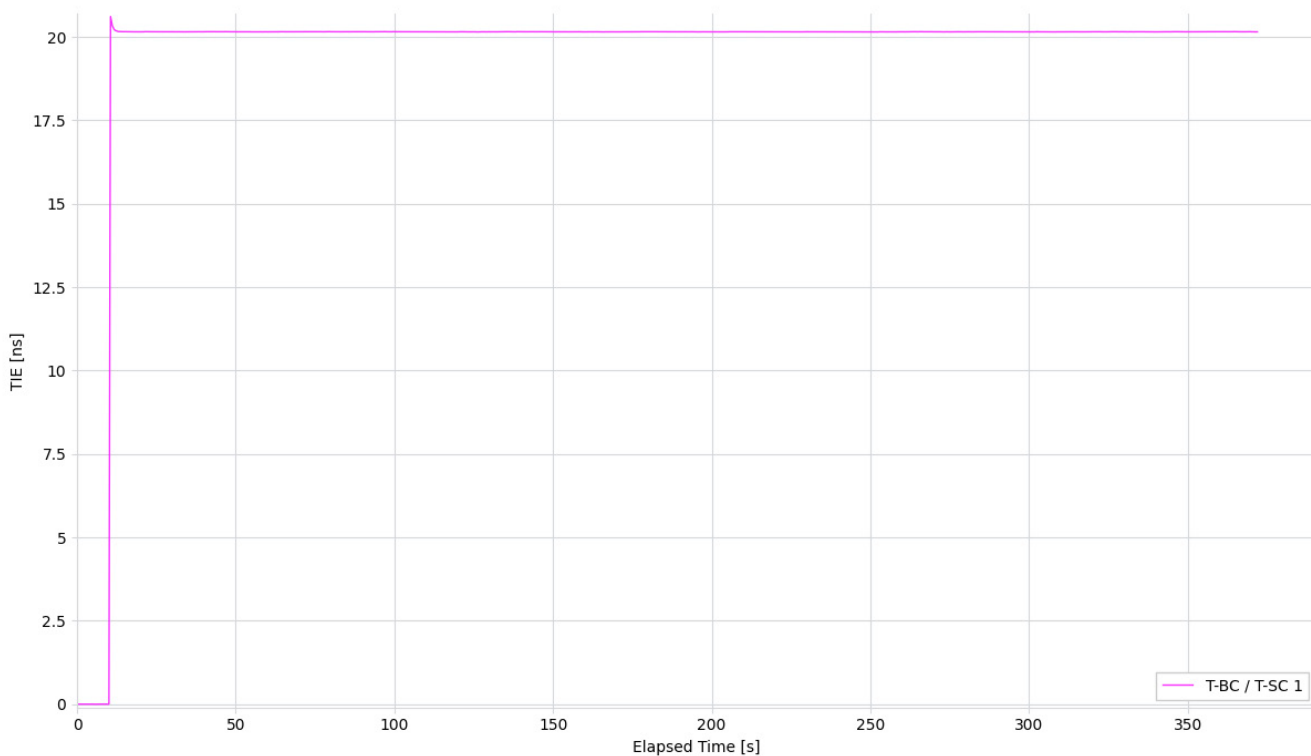

Figure 84. Phase Discontinuity – G.8262 EEC Option 1, 10Hz – TIE (no mask)

	T-BC / T-SC 1
Mean [ns]	19.596
Min [ns]	-0.003
Max [ns]	20.613
Max-Min [ns]	20.616

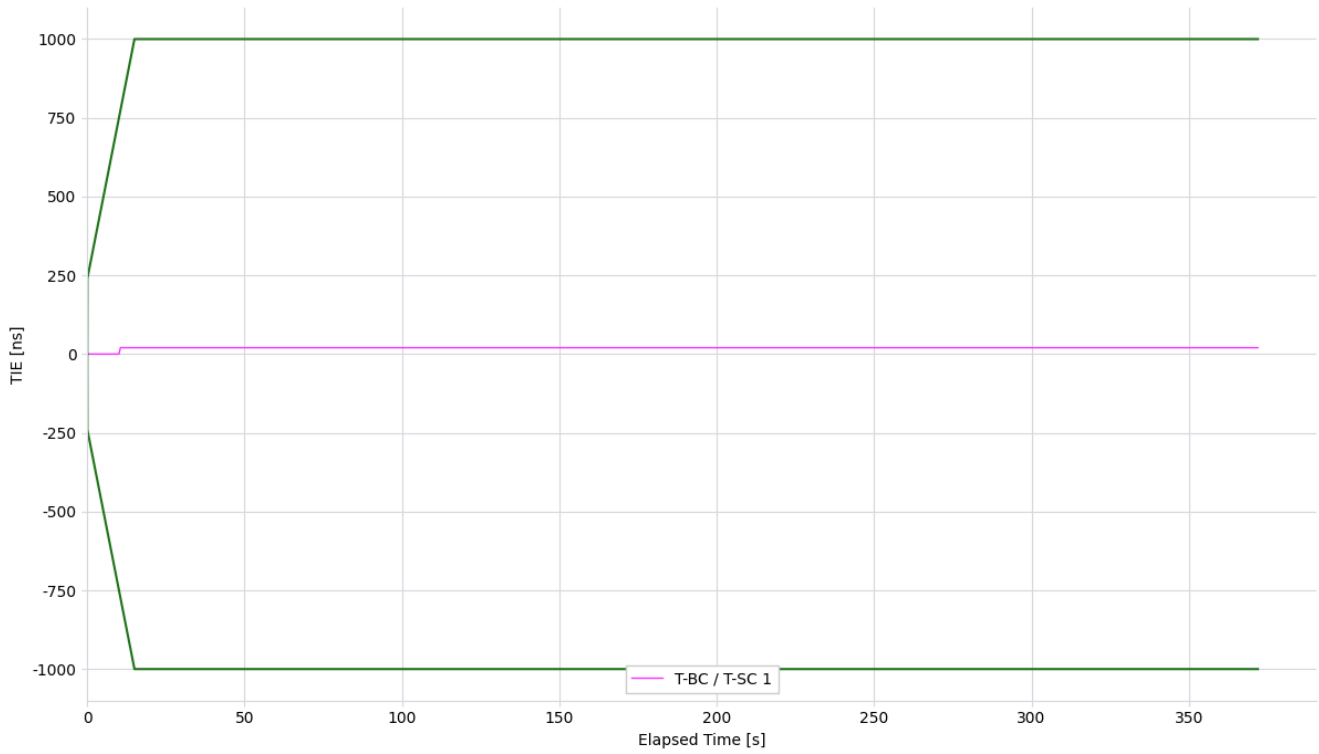

Figure 85. Phase Discontinuity – G.8262 EEC Option 1, 10Hz – TIE

	T-BC / T-SC 1
Mean [ns]	19.596
Min [ns]	-0.003
Max [ns]	20.613
Max-Min [ns]	20.616

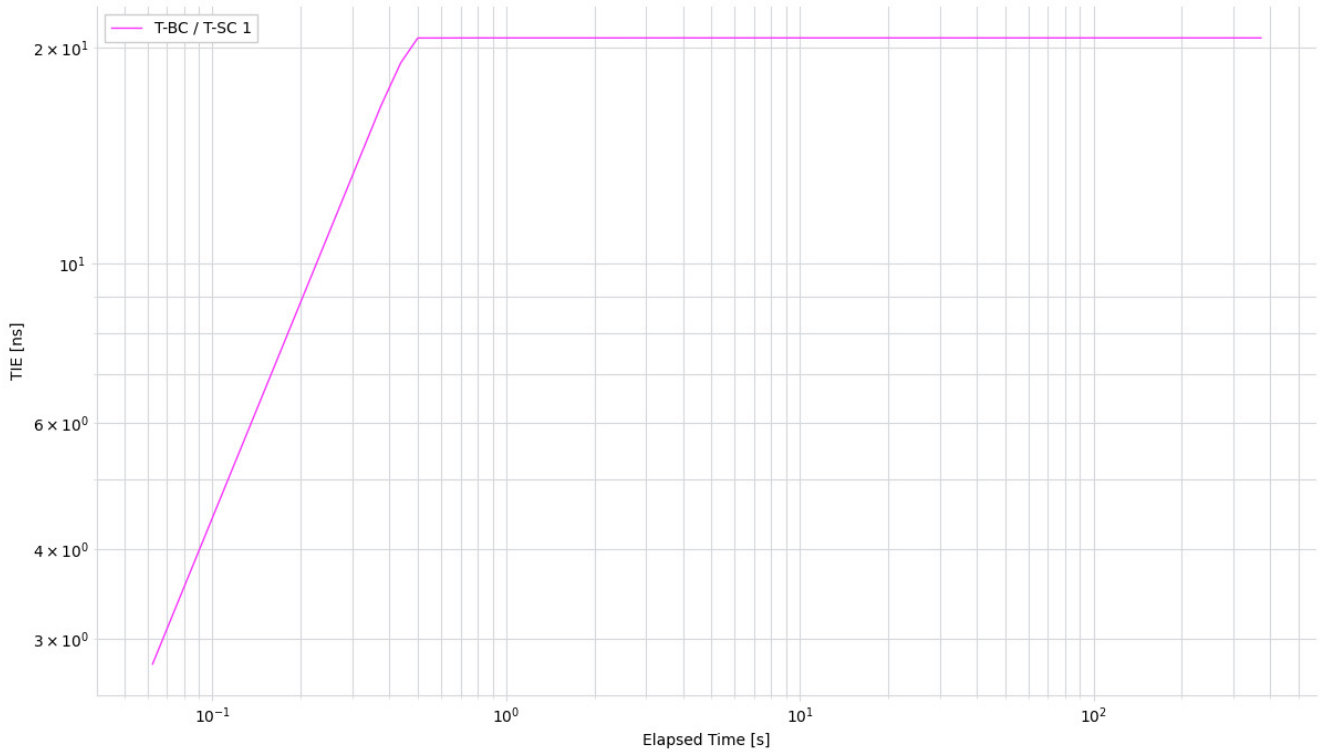

Figure 86. Phase Discontinuity – G.8262 EEC Option 1, 10Hz – MTIE

	T-BC / T-SC 1
Min [ns]	2.765
Max [ns]	20.616
Max-Min [ns]	17.851

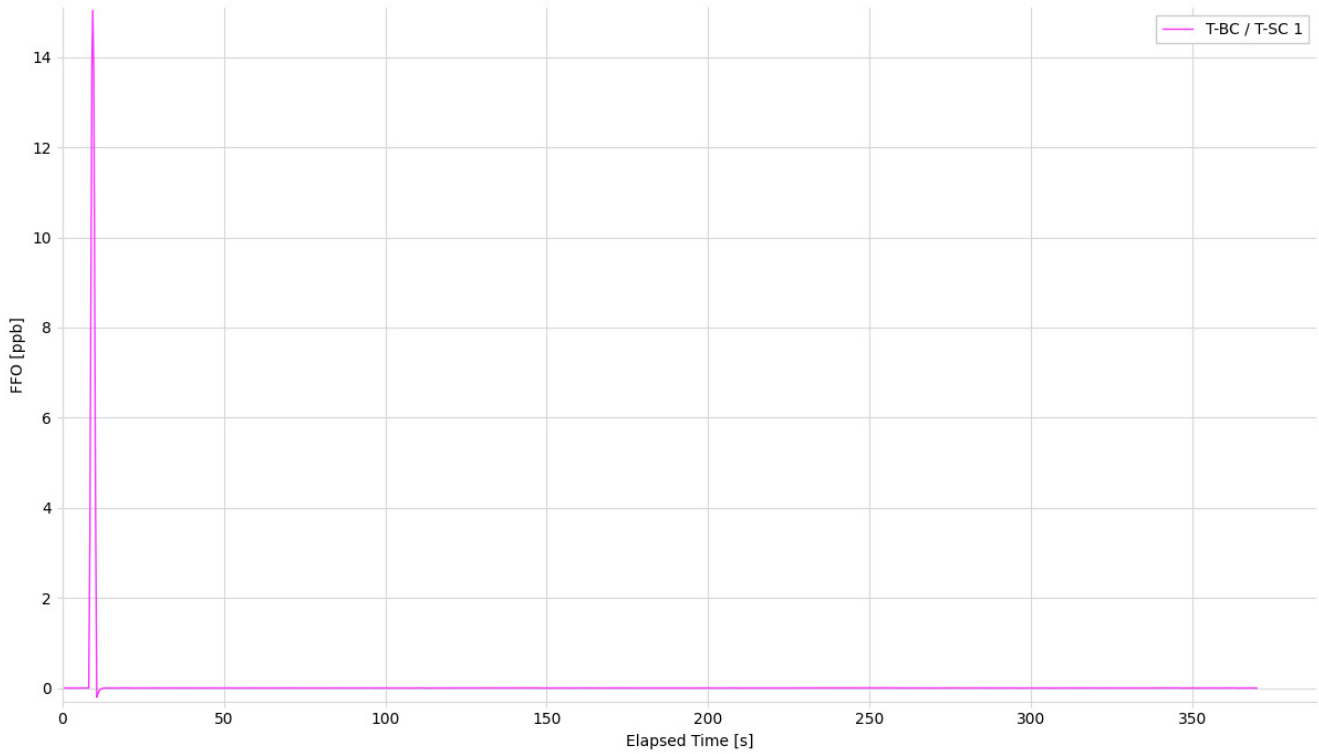

Figure 87. Phase Discontinuity – G.8262 EEC Option 1, 10Hz – FFO

	T-BC / T-SC 1
Mean [ppb]	0.055
Min [ppb]	-0.206
Max [ppb]	15.037
Max-Min [ppb]	15.243

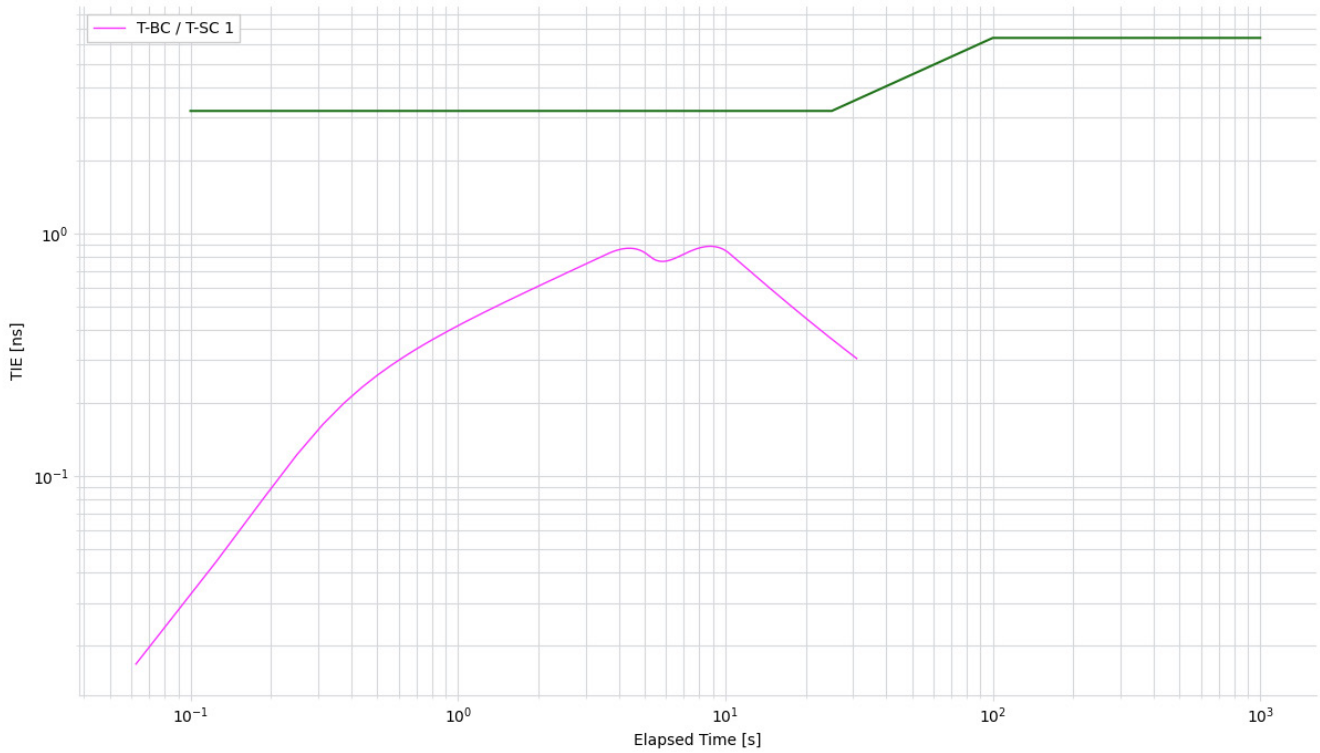

Figure 88. Phase Discontinuity – G.8262 EEC Option 1, 10Hz – TDEV

	T-BC / T-SC 1
Min [ns]	0.017
Max [ns]	0.885
Max-Min [ns]	0.869

7.2.3. Phase Discontinuity – G.8262 EEC Option 2, 0.1Hz

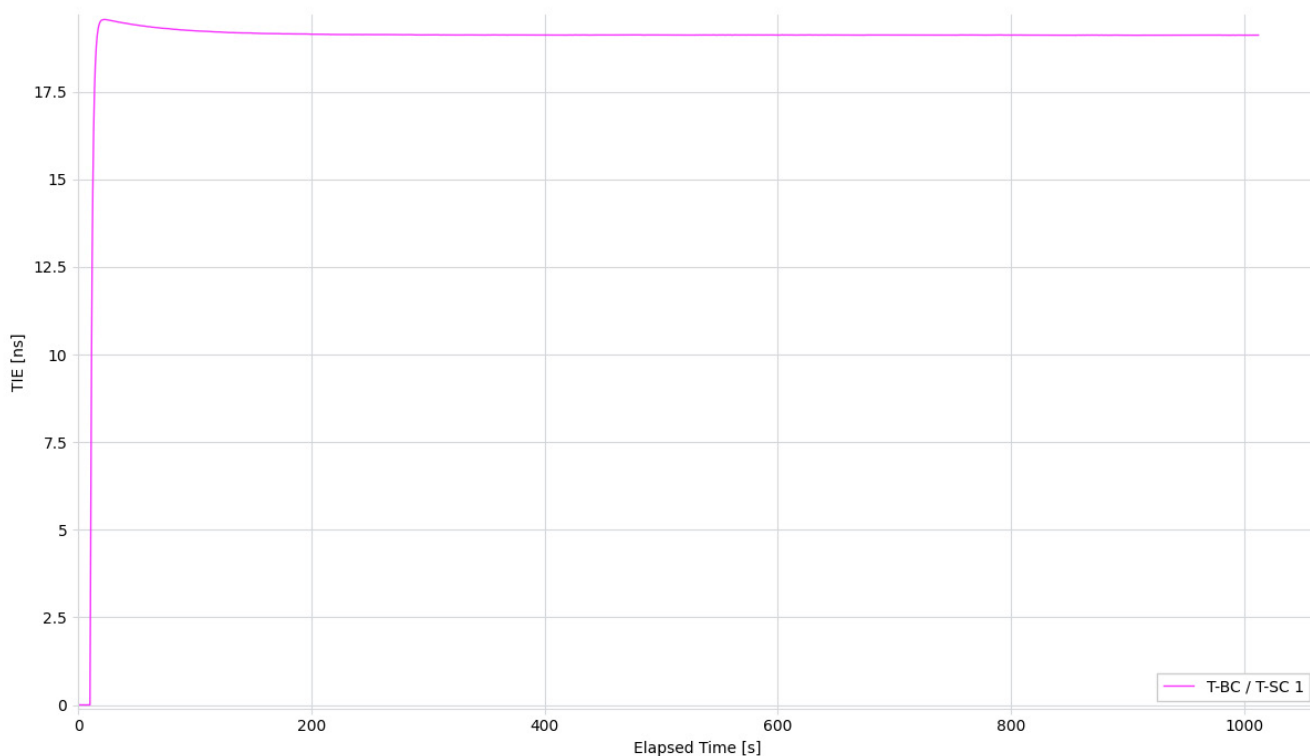

Figure 89. Phase Discontinuity – G.8262 EEC Option 2, 0.1Hz – TIE

	T-BC / T-SC 1
Mean [ns]	18.92
Min [ns]	0.0
Max [ns]	19.562
Max-Min [ns]	19.562

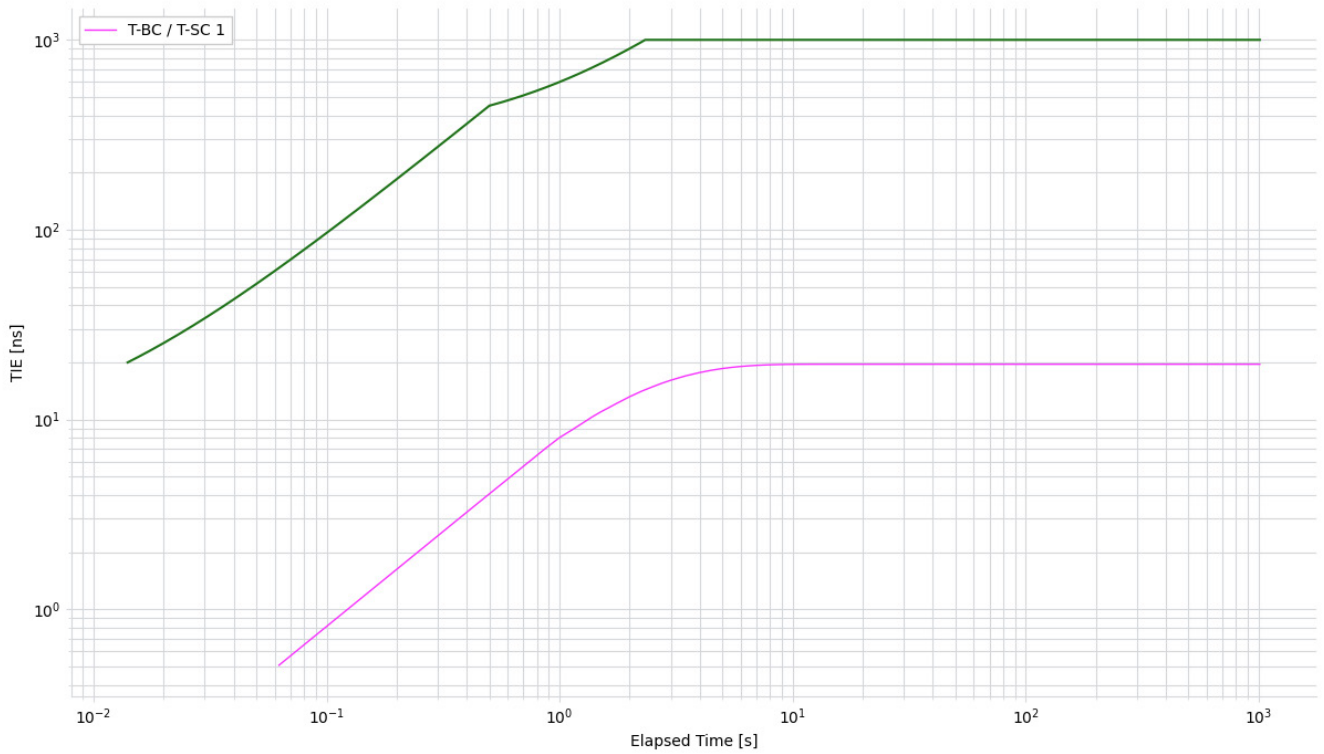

Figure 90. Phase Discontinuity – G.8262 EEC Option 2, 0.1Hz – MTIE

	T-BC / T-SC 1
Min [ns]	0.508
Max [ns]	19.562
Max-Min [ns]	19.054

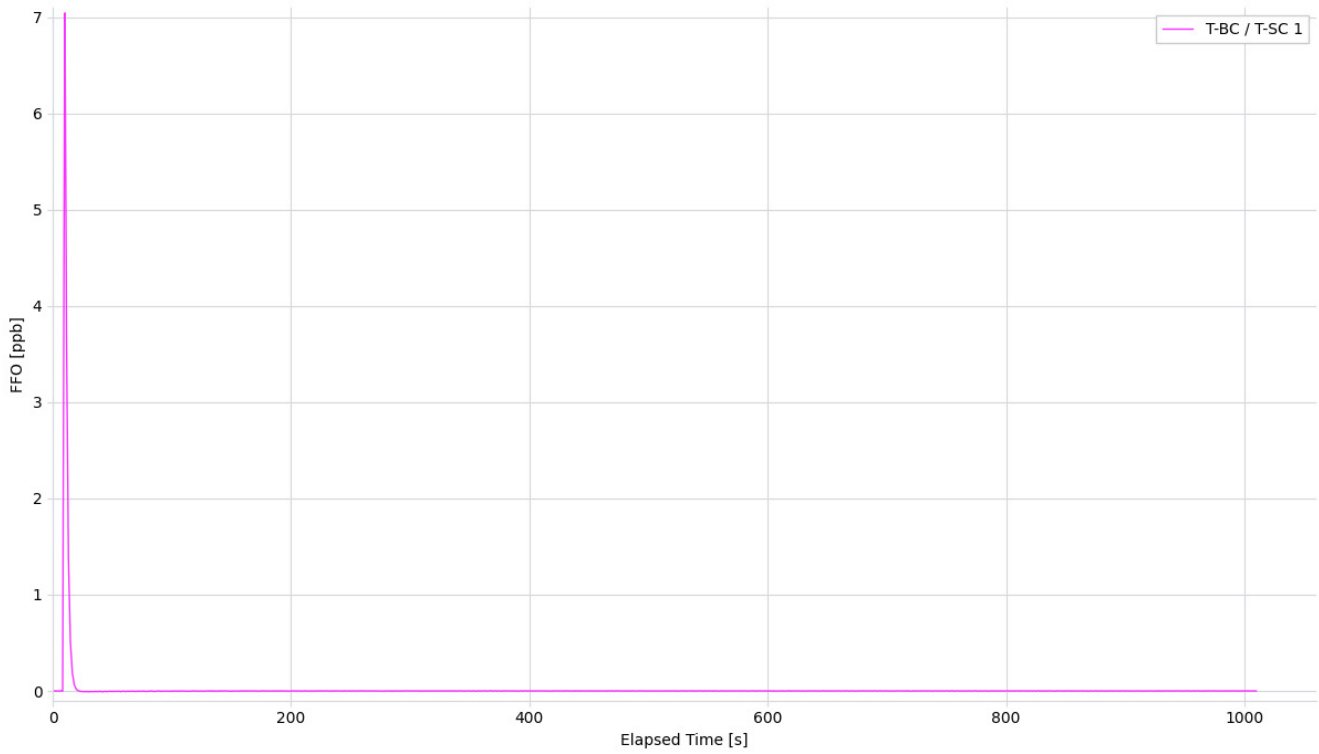

Figure 91. Phase Discontinuity – G.8262 EEC Option 2, 0.1Hz – FFO

	T-BC / T-SC 1
Mean [ppb]	0.02
Min [ppb]	-0.009
Max [ppb]	7.045
Max-Min [ppb]	7.053

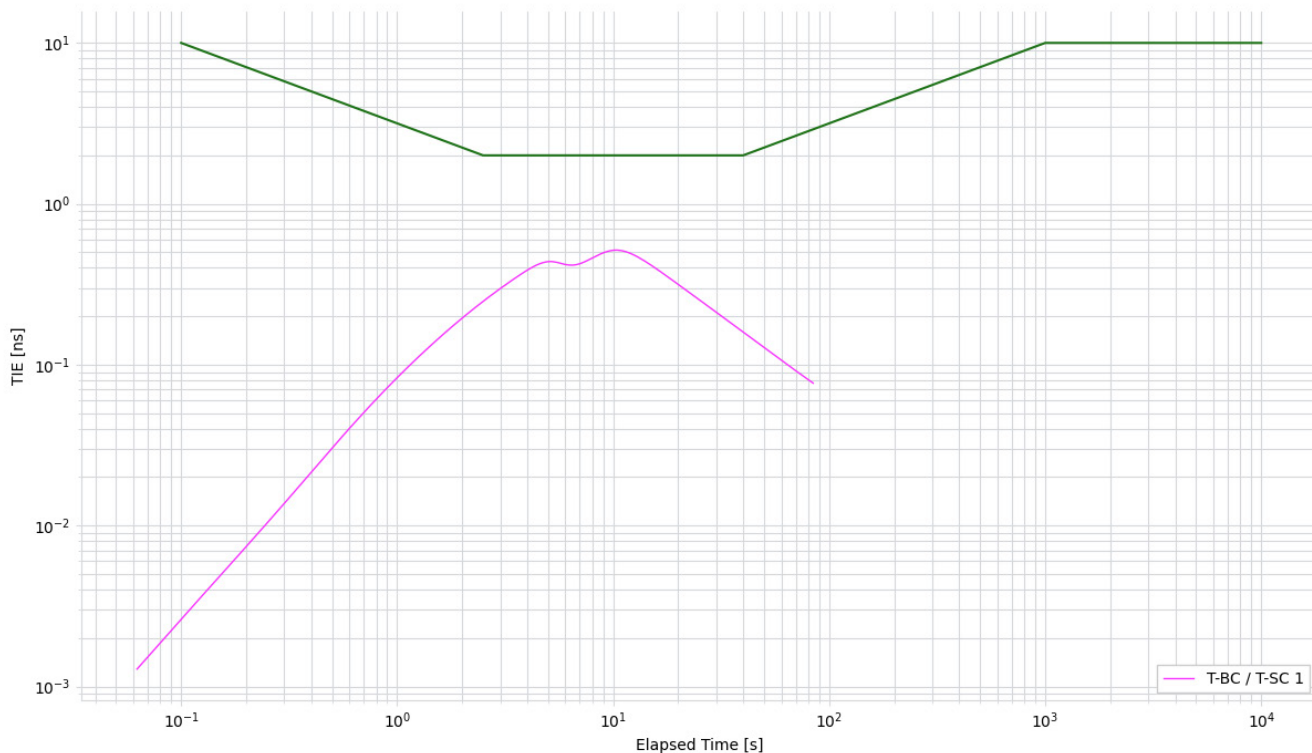

Figure 92. Phase Discontinuity – G.8262 EEC Option 2, 0.1Hz – TDEV

	T-BC / T-SC 1
Min [ns]	0.001
Max [ns]	0.515
Max-Min [ns]	0.514

7.2.4. Phase Discontinuity – G.8262.1 eEEC, 3Hz

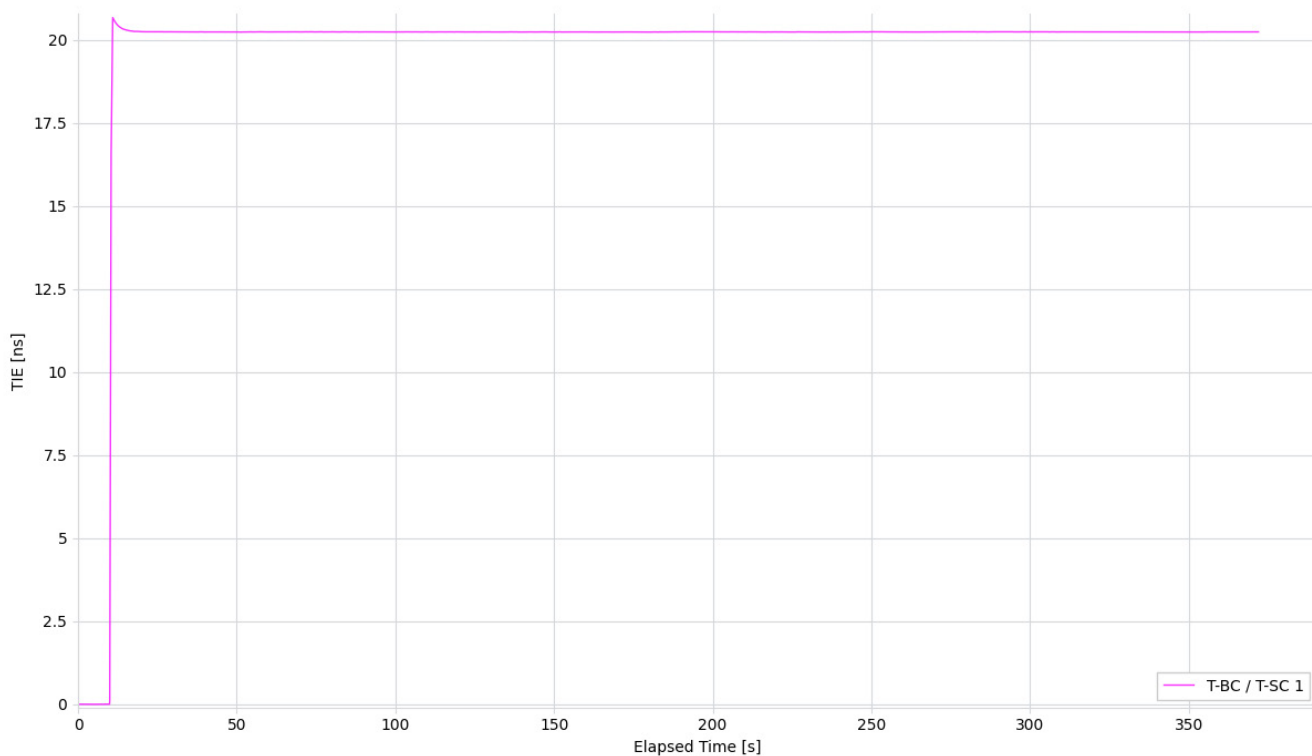

Figure 93. Phase Discontinuity – G.8262.1 eEEC, 3Hz – TIE (no mask)

	T-BC / T-SC 1
Mean [ns]	19.689
Min [ns]	-0.005
Max [ns]	20.678
Max-Min [ns]	20.683

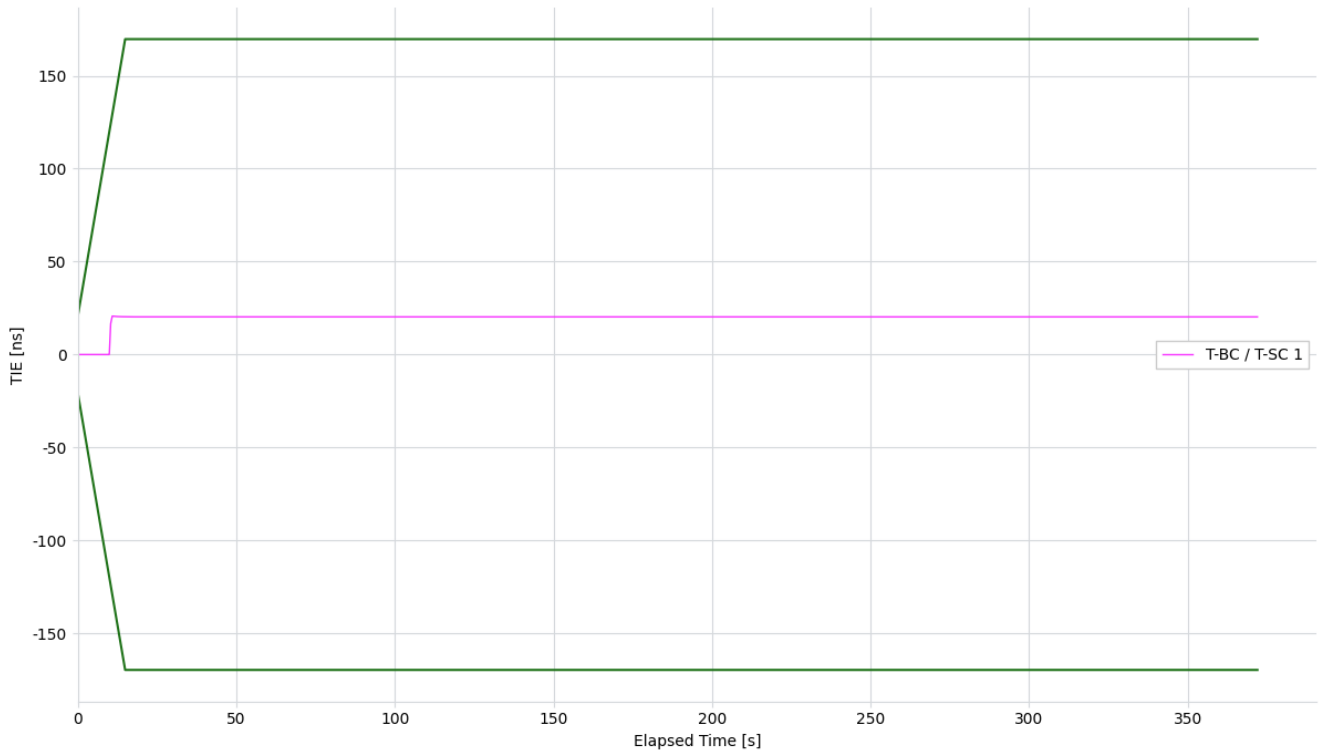

Figure 94. Phase Discontinuity – G.8262.1 eEEC, 3Hz – TIE

	T-BC / T-SC 1
Mean [ns]	19.689
Min [ns]	-0.005
Max [ns]	20.678
Max-Min [ns]	20.683

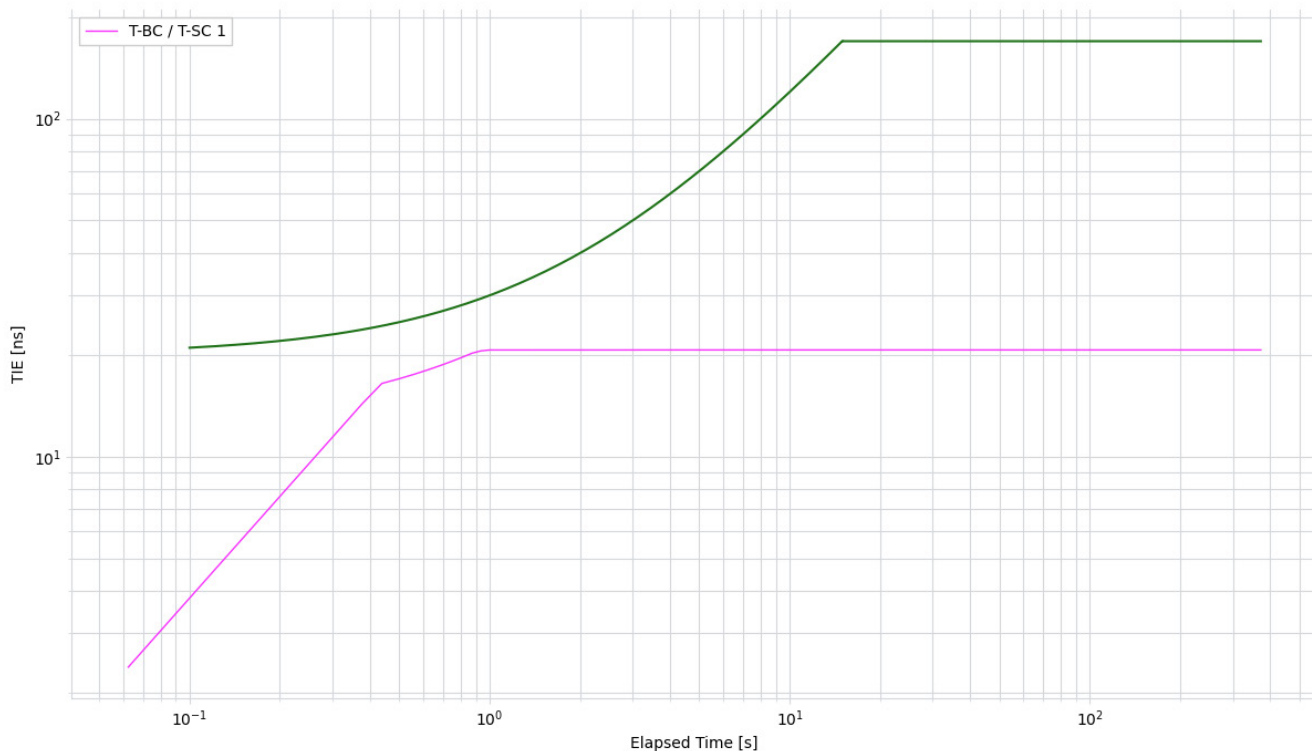

Figure 95. Phase Discontinuity – G.8262.1 eEEEC, 3Hz – MTIE

	T-BC / T-SC 1
Min [ns]	2.382
Max [ns]	20.683
Max-Min [ns]	18.302

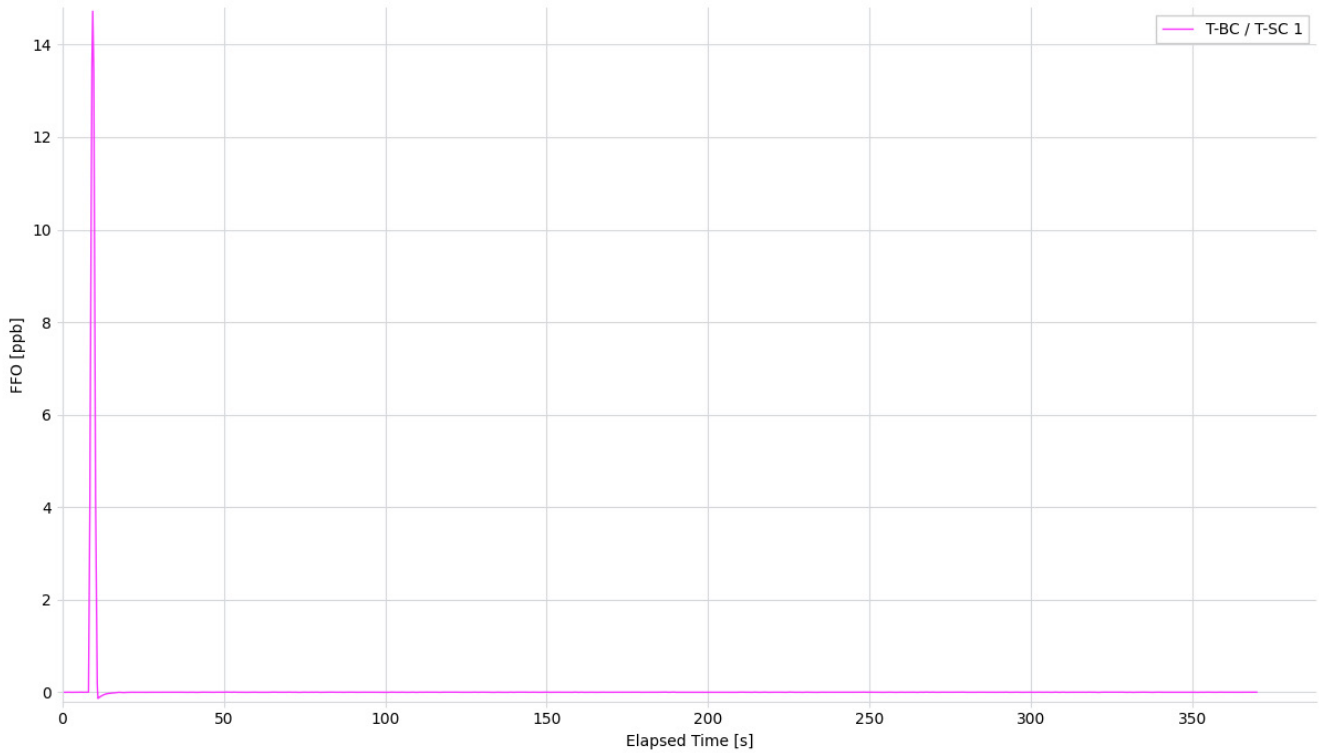

Figure 96. Phase Discontinuity – G.8262.1 eEEC, 3Hz – FFO

	T-BC / T-SC 1
Mean [ppb]	0.055
Min [ppb]	-0.135
Max [ppb]	14.721
Max-Min [ppb]	14.856

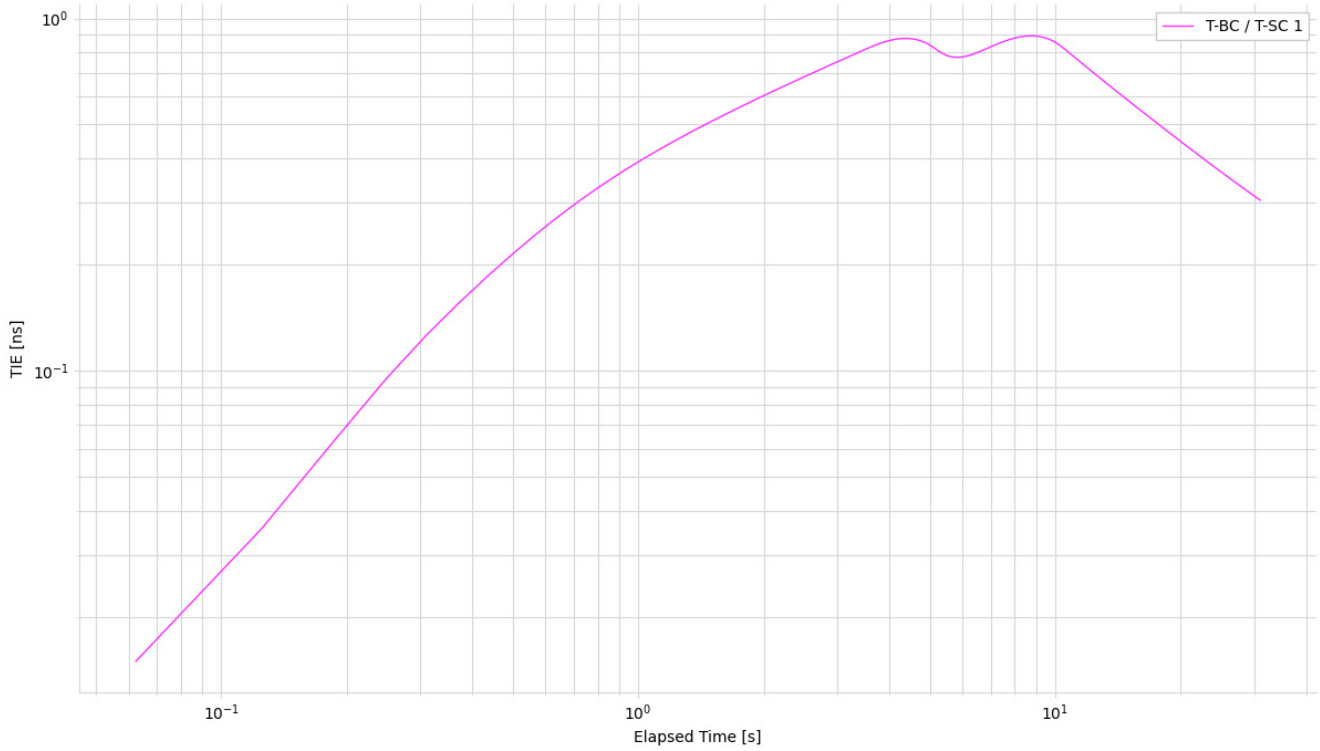

Figure 97. Phase Discontinuity – G.8262.1 eEEC, 3Hz – TDEV

	T-BC / T-SC 1
Min [ns]	0.015
Max [ns]	0.893
Max-Min [ns]	0.878

7.3 Short-term Phase Transient Response

Short-term phase transient response requirement reflects the performance of the DUT in cases when the (selected) input reference is lost due to a failure in the reference path and a second reference input signal, traceable to the same reference clock, is available simultaneously, or shortly after the detection of the failure (see Figure 1 for the equipment configuration).

The test was carried out by providing reference clock inputs on IN_A and IN_B from the Frequency Generator which are 180° out of phase from each other. The PLL is locked to the clock signal from IN_A for a period of time. A transient is produced by turning off the input reference signal for 11 seconds and during this time the clock on IN_B is unavailable. The DPLL goes into holdover during the 11 second period as no other reference is available. After 11 seconds, the reference signal on IN_B is turned ON and PLL locks to the newly available reference signal. The output from the DUT is available on OUT_0 and the phase time error is captured using the Frequency Counter. The results of the given transient are plotted against the applicable standard profiles.

- Locked to IN_A → Holdover (11s) → Locked to IN_B

7.3.1. Short-term Phase Transient Response – G.8262 EEC Option 1, 1.2Hz

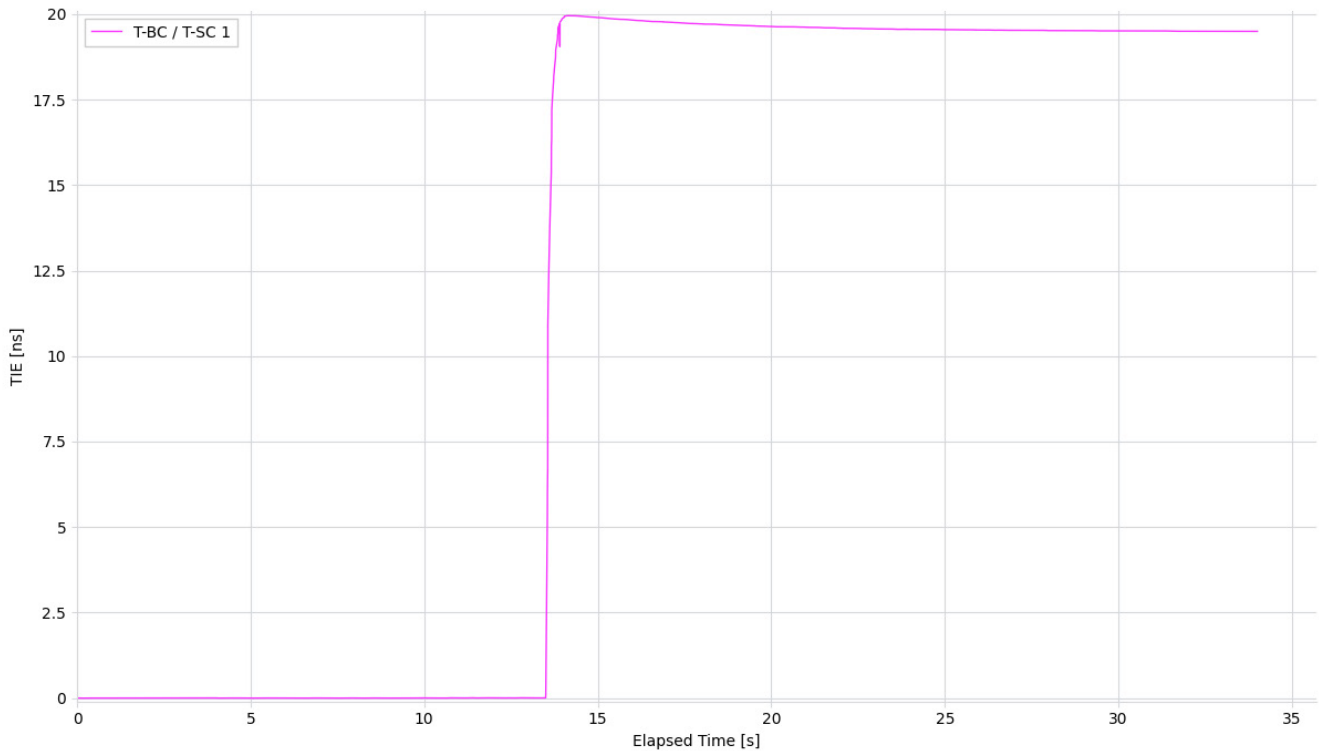

Figure 98. Short-term Phase Transient Response – G.8262 EEC Option 1, 1.2Hz – TIE (no mask)

	T-BC / T-SC 1
Mean [ns]	11.772
Min [ns]	-0.003
Max [ns]	19.956
Max-Min [ns]	19.959

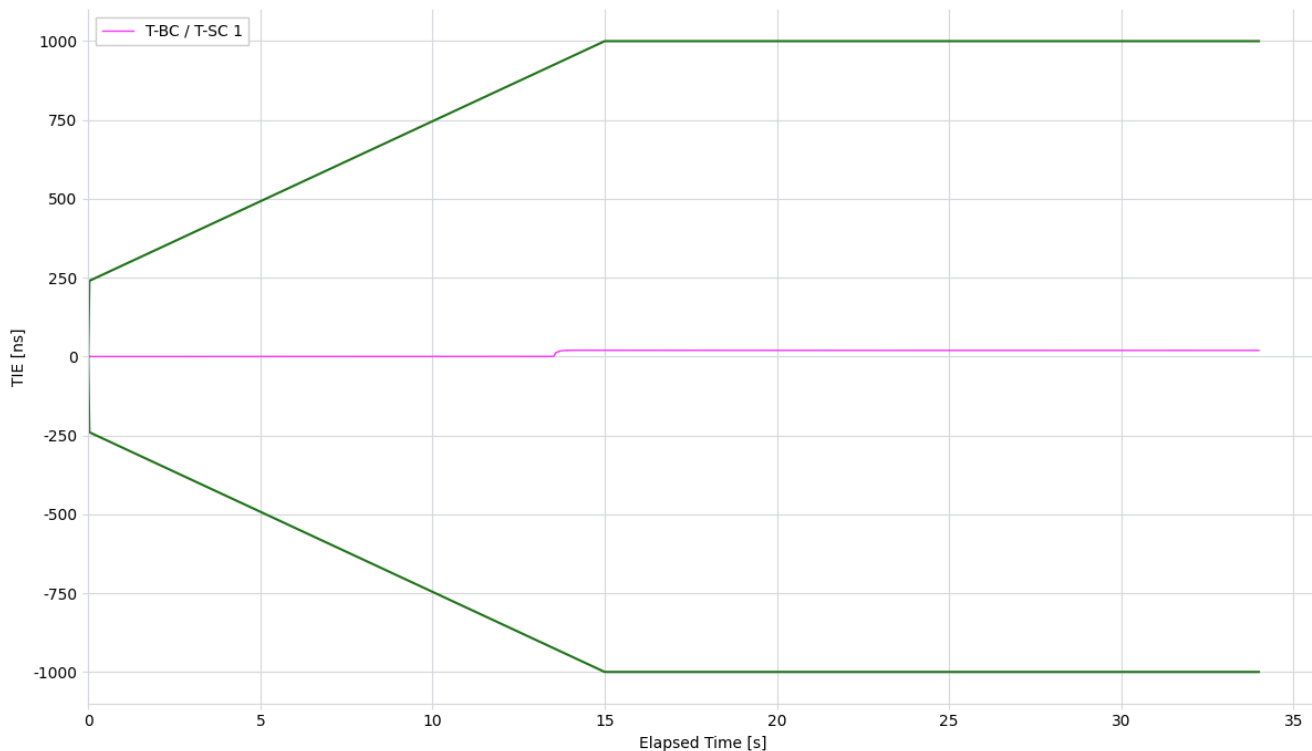

Figure 99. Short-term Phase Transient Response – G.8262 EEC Option 1, 1.2Hz – TIE

	T-BC / T-SC 1
Mean [ns]	11.772
Min [ns]	-0.003
Max [ns]	19.956
Max-Min [ns]	19.959

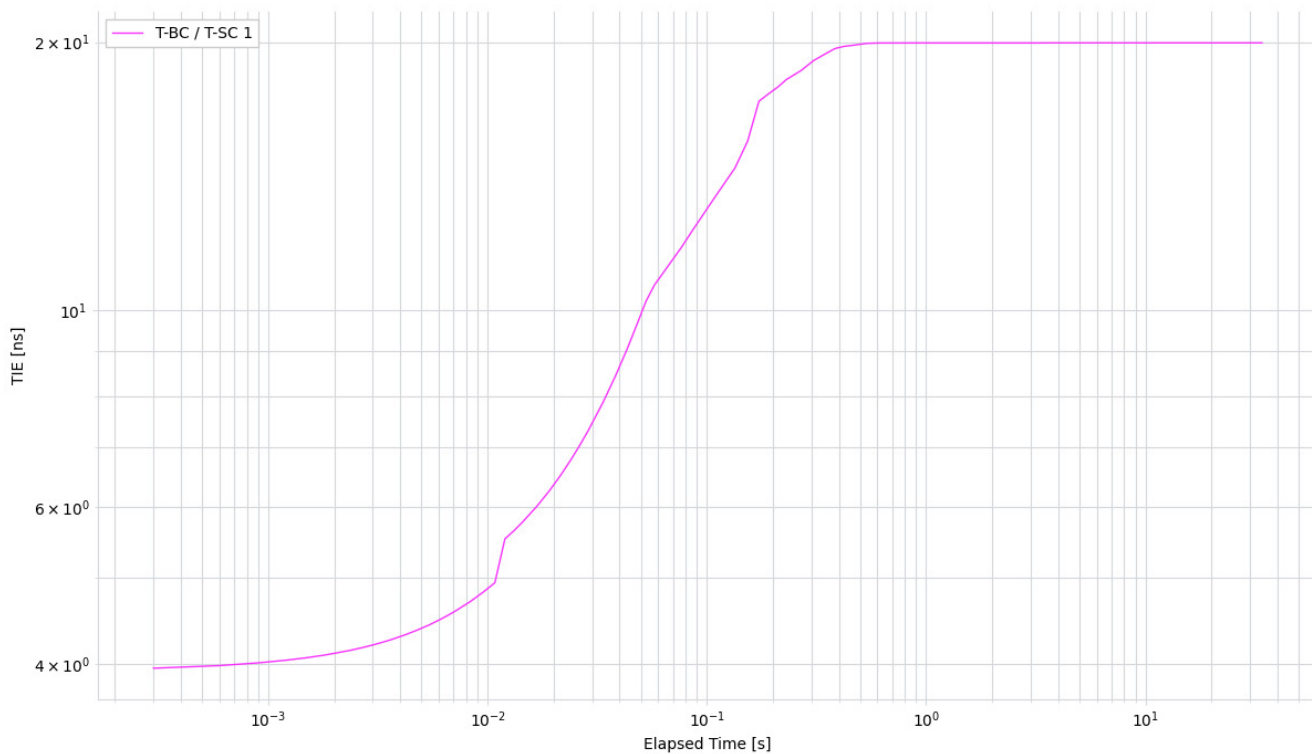

Figure 100. Short-term Phase Transient Response – G.8262 EEC Option 1, 1.2Hz – MTIE

	T-BC / T-SC 1
Min [ns]	3.955
Max [ns]	19.959
Max-Min [ns]	16.004

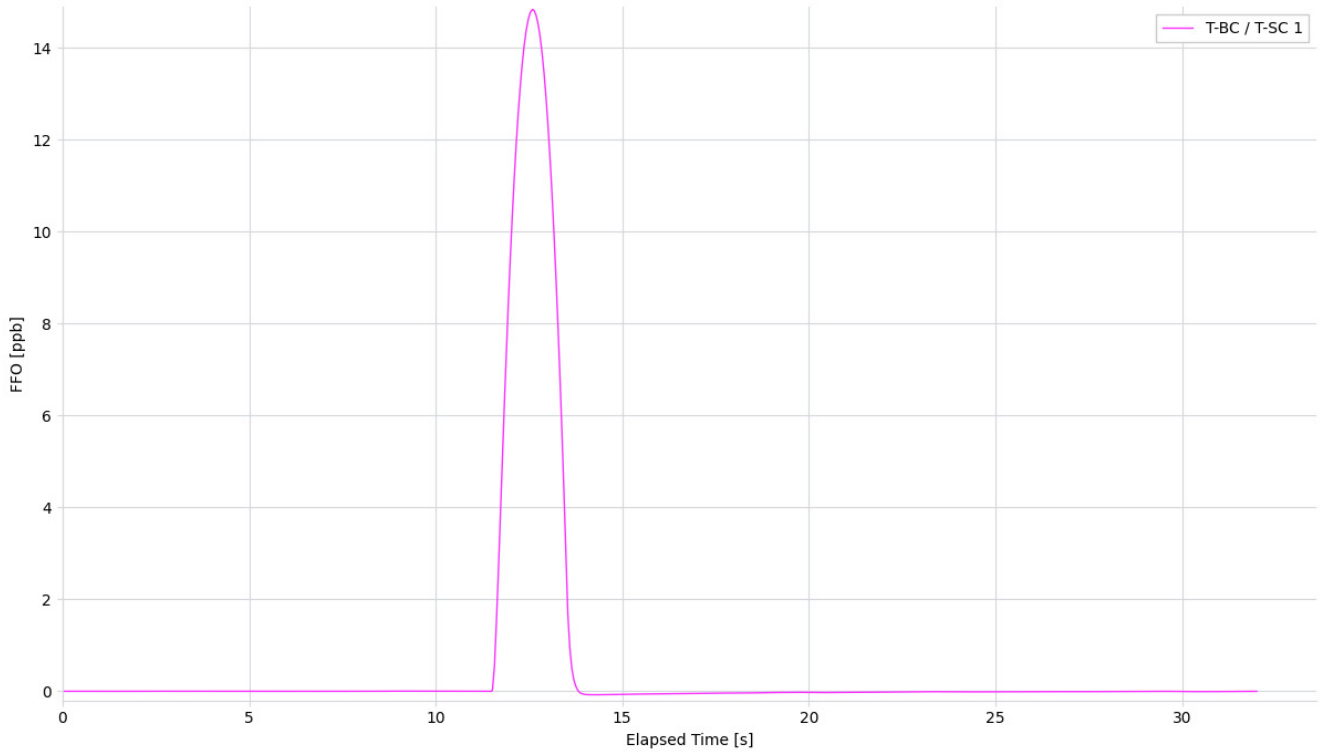

Figure 101. Short-term Phase Transient Response – G.8262 EEC Option 1, 1.2Hz – FFO

	T-BC / T-SC 1
Mean [ppb]	0.609
Min [ppb]	-0.076
Max [ppb]	14.837
Max-Min [ppb]	14.912

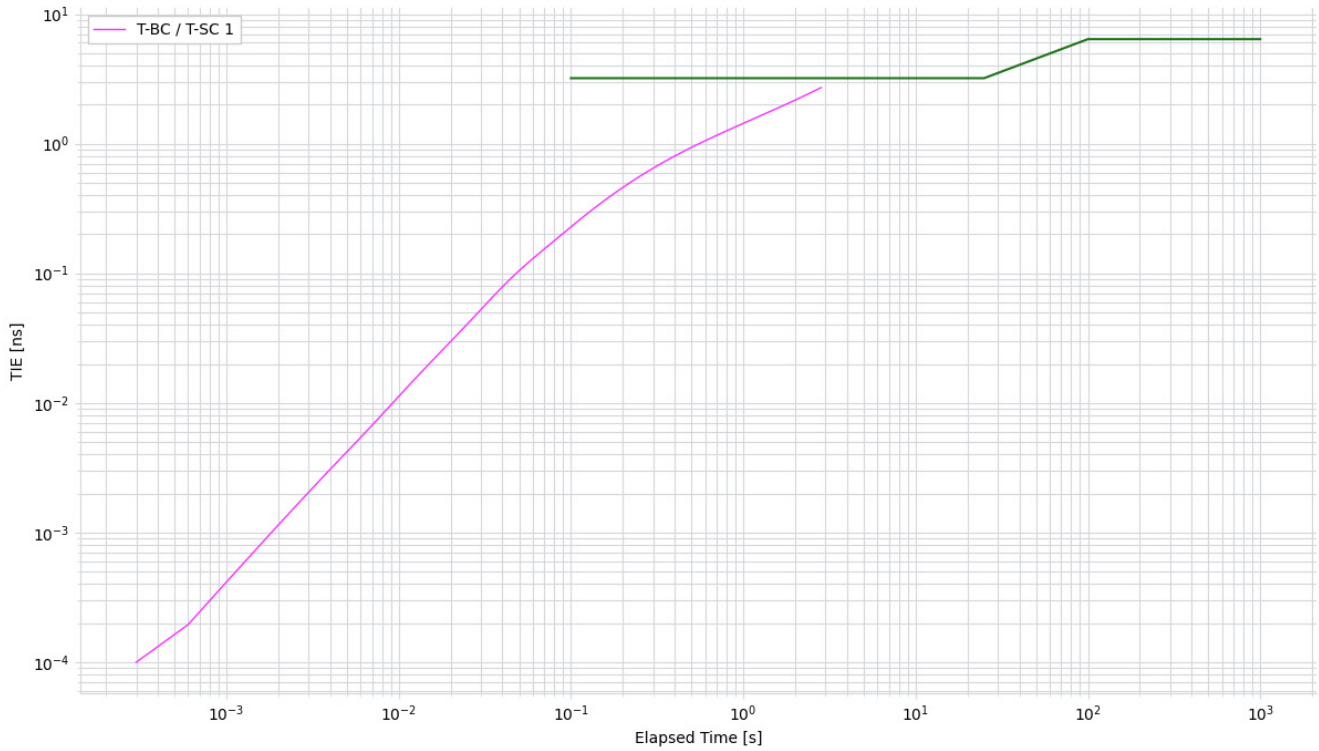

Figure 102. Short-term Phase Transient Response – G.8262 EEC Option 1, 1.2Hz – TDEV

	T-BC / T-SC 1
Min [ns]	0.0
Max [ns]	2.708
Max-Min [ns]	2.708

7.3.2. Short-term Phase Transient Response – G.8262 EEC Option 1, 10Hz

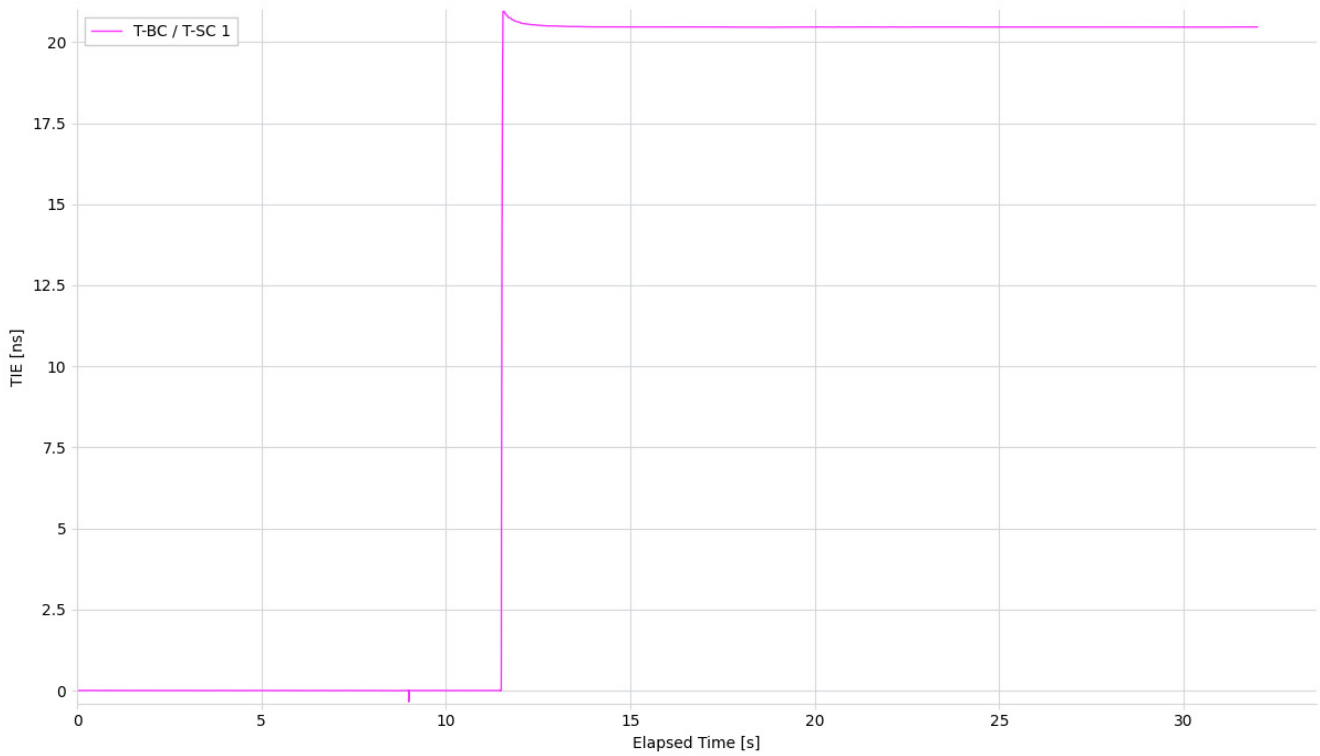

Figure 103. Short-term Phase Transient Response – G.8262 EEC Option 1, 10Hz – TIE (no mask)

	T-BC / T-SC 1
Mean [ns]	13.104
Min [ns]	-0.348
Max [ns]	20.948
Max-Min [ns]	21.296

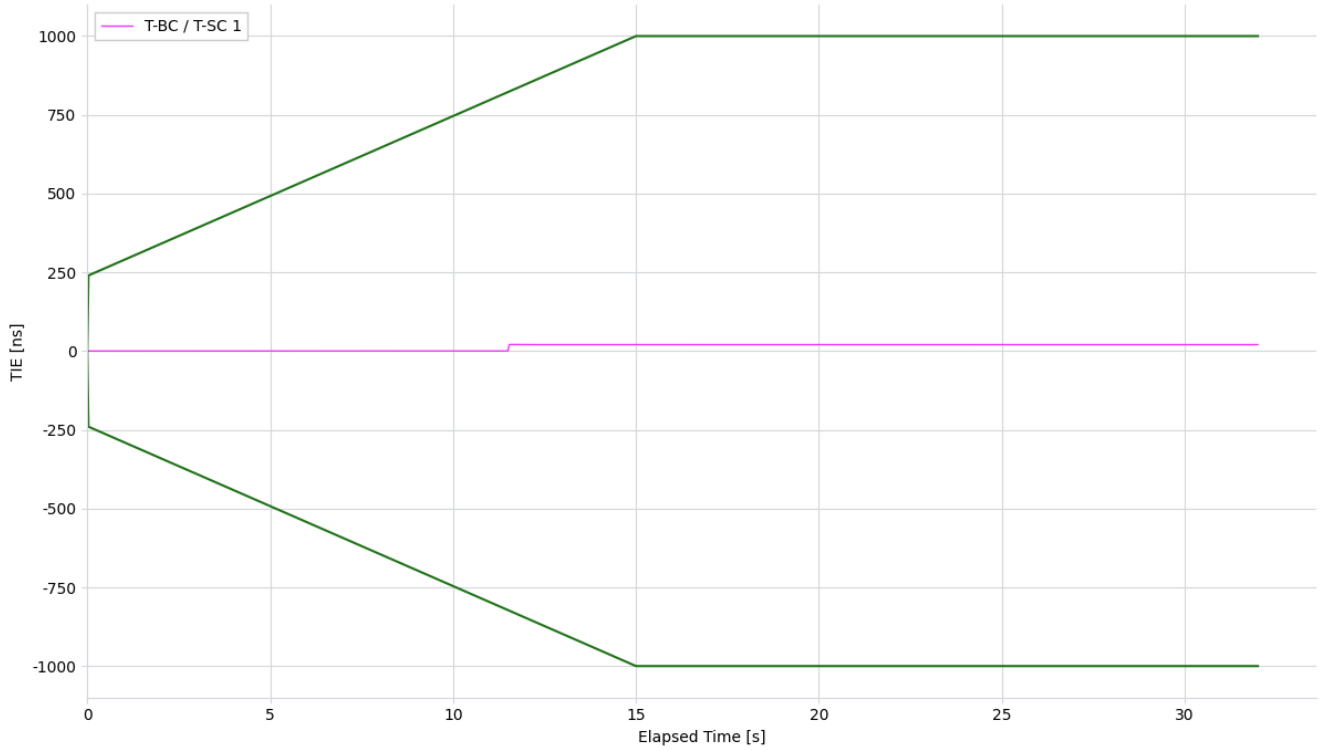

Figure 104. Short-term Phase Transient Response – G.8262 EEC Option 1, 10Hz – TIE

	T-BC / T-SC 1
Mean [ns]	13.104
Min [ns]	-0.348
Max [ns]	20.948
Max-Min [ns]	21.296

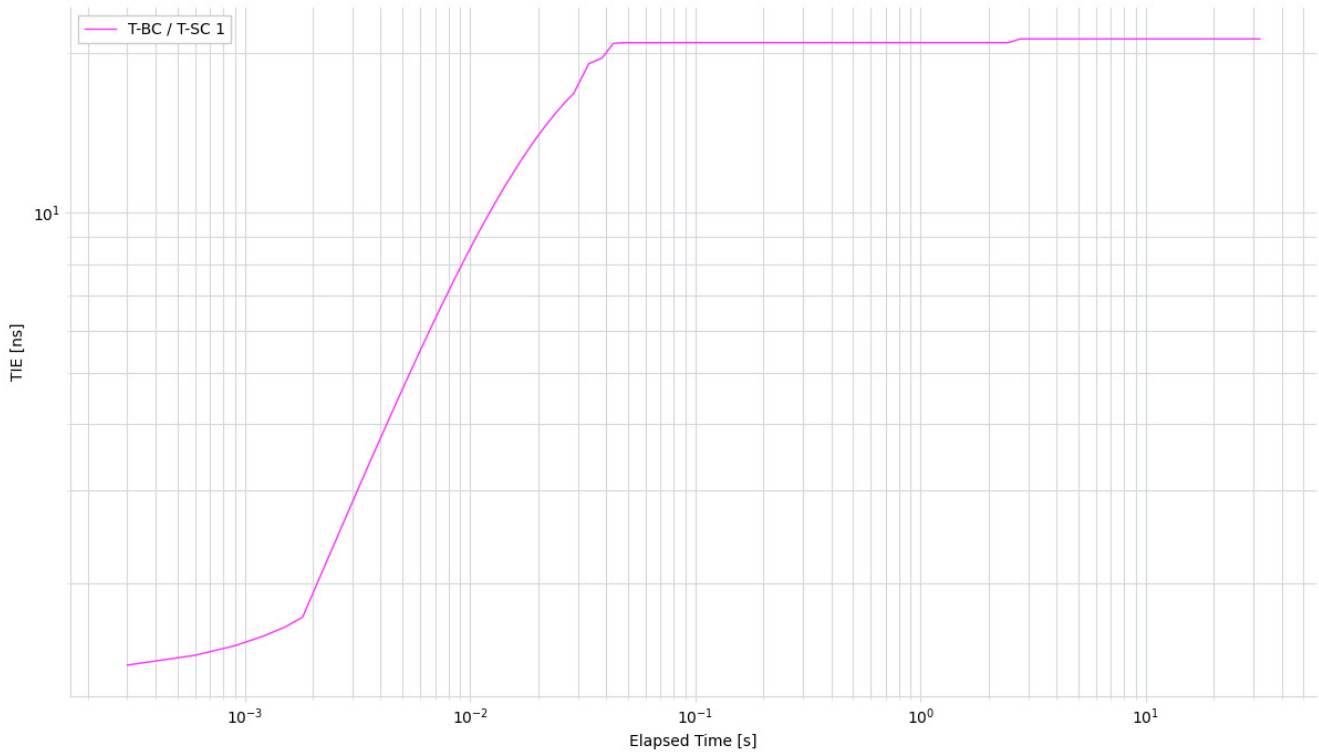

Figure 105. Short-term Phase Transient Response – G.8262 EEC Option 1, 10Hz – MTIE

	T-BC / T-SC 1
Min [ns]	1.402
Max [ns]	21.296
Max-Min [ns]	19.894

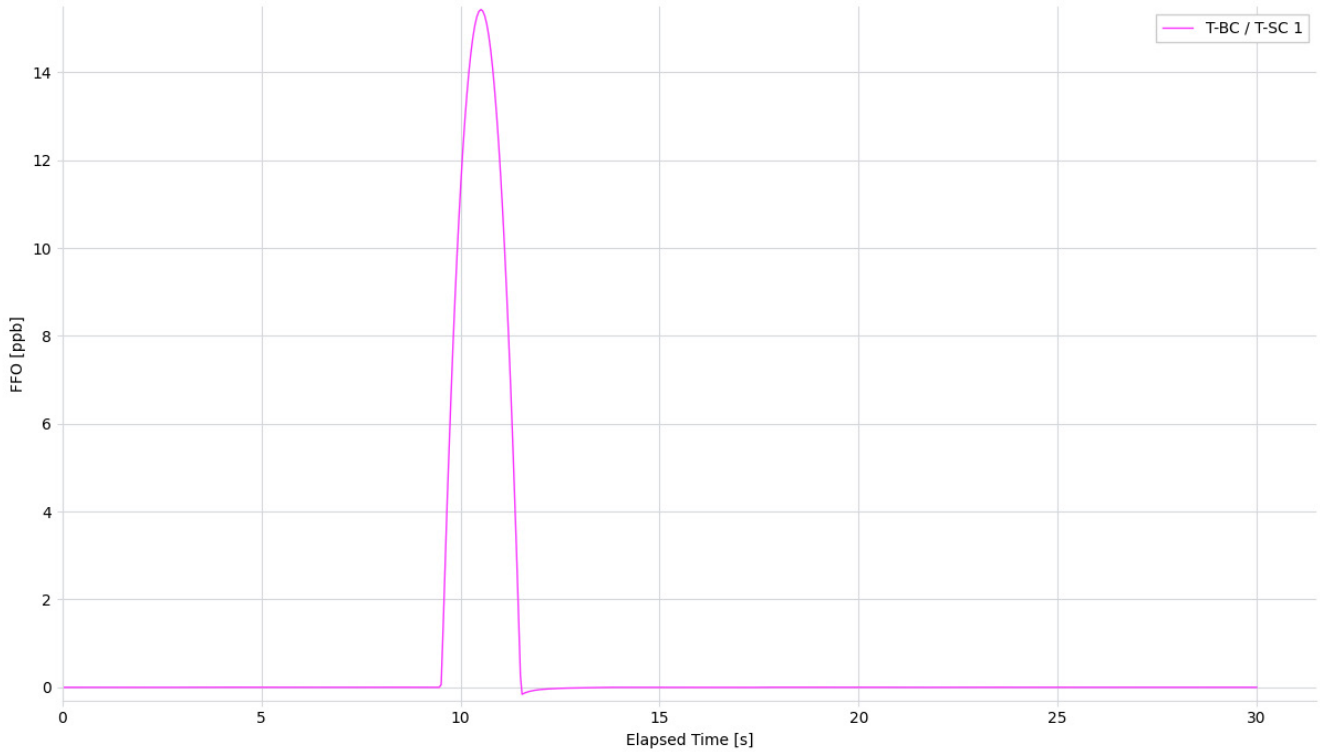

Figure 106. Short-term Phase Transient Response – G.8262 EEC Option 1, 10Hz – FFO

	T-BC / T-SC 1
Mean [ppb]	0.681
Min [ppb]	-0.159
Max [ppb]	15.433
Max-Min [ppb]	15.592

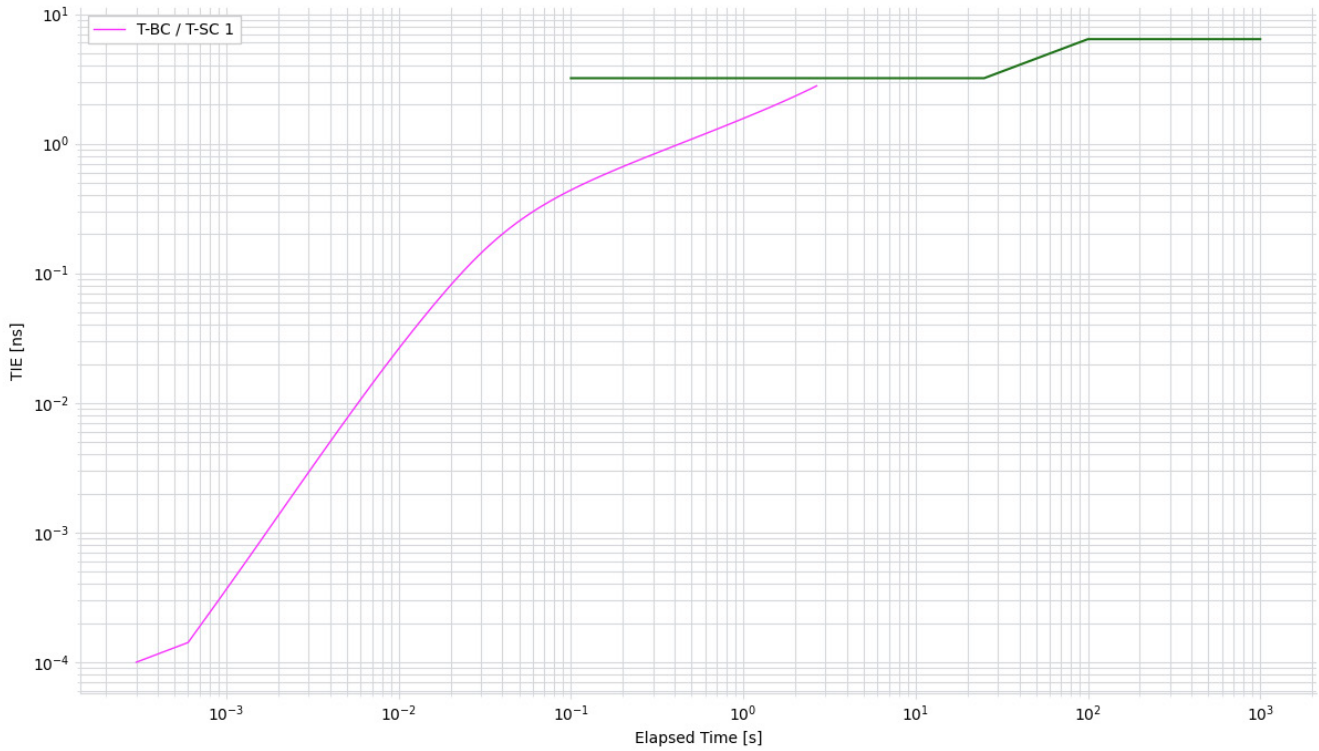

Figure 107. Short-term Phase Transient Response – G.8262 EEC Option 1, 10Hz – TDEV

	T-BC / T-SC 1
Min [ns]	0.0
Max [ns]	2.793
Max-Min [ns]	2.793

7.3.3. Short-term Phase Transient Response – G.8262 EEC Option 2, 0.1Hz

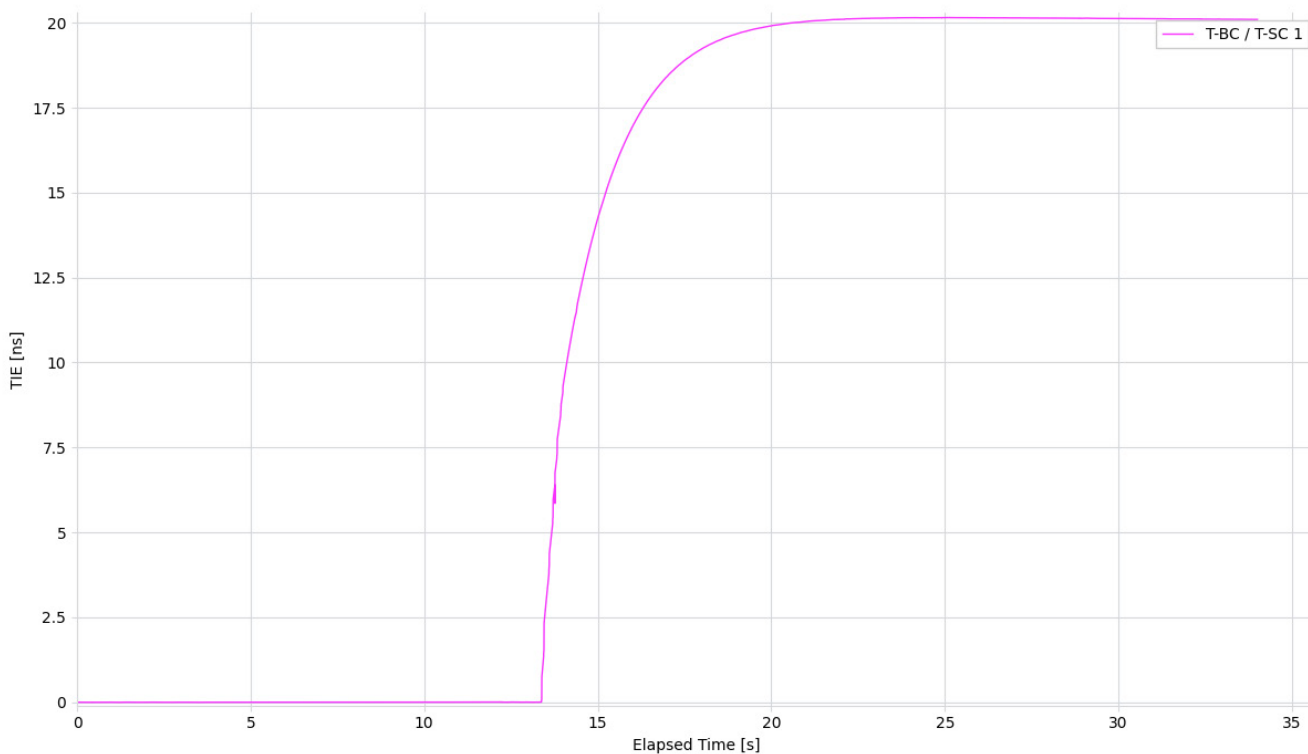

Figure 108. Short-term Phase Transient Response – G.8262 EEC Option 2, 0.1Hz – TIE

	T-BC / T-SC 1
Mean [ns]	11.428
Min [ns]	-0.005
Max [ns]	20.154
Max-Min [ns]	20.159

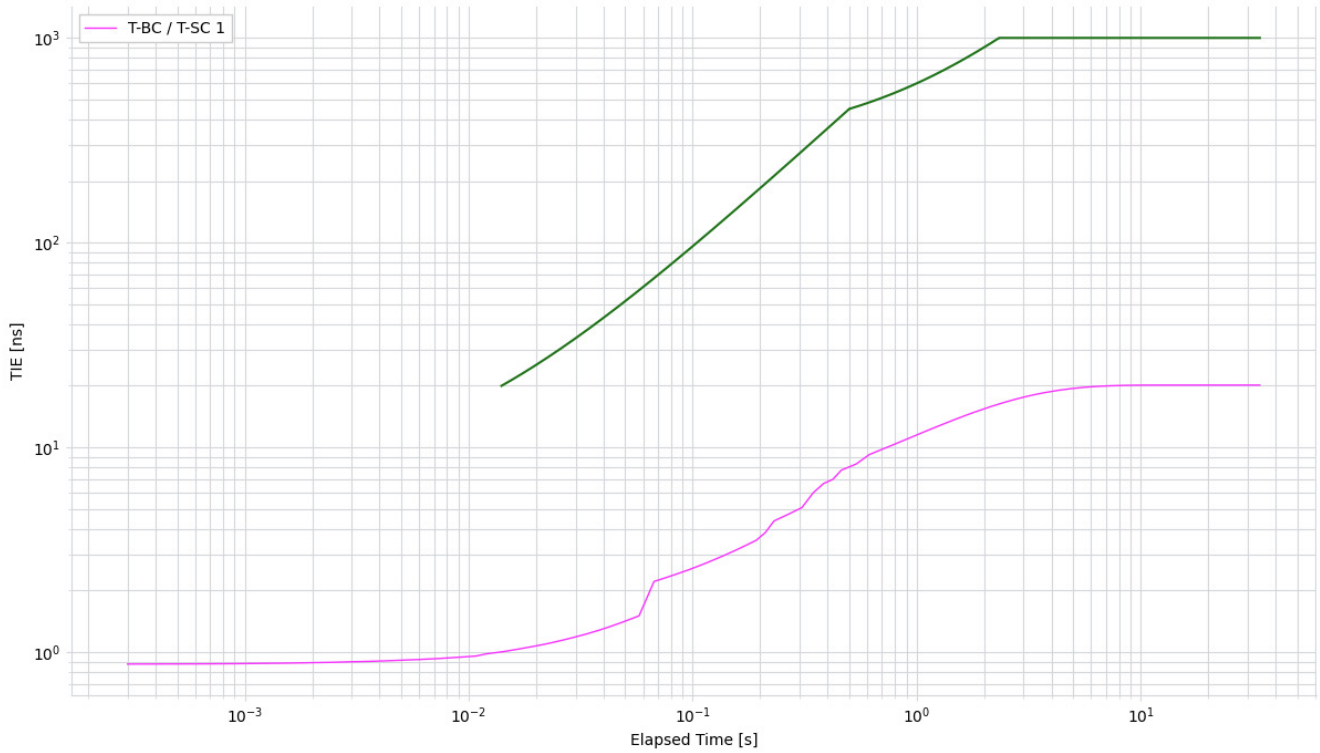

Figure 109. Short-term Phase Transient Response – G.8262 EEC Option 2, 0.1Hz – MTIE

	T-BC / T-SC 1
Min [ns]	0.875
Max [ns]	20.159
Max-Min [ns]	19.284

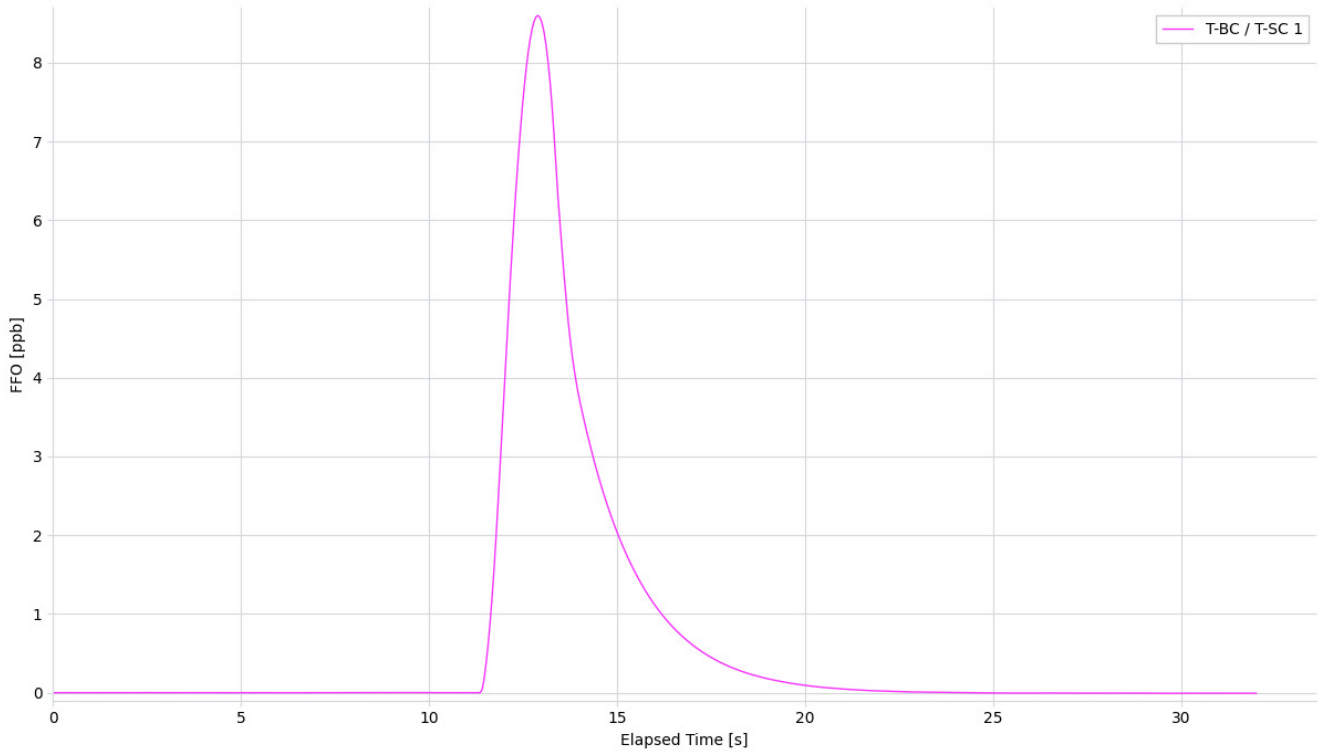

Figure 110. Short-term Phase Transient Response – G.8262 EEC Option 2, 0.1Hz – FFO

	T-BC / T-SC 1
Mean [ppb]	0.628
Min [ppb]	-0.008
Max [ppb]	8.599
Max-Min [ppb]	8.607

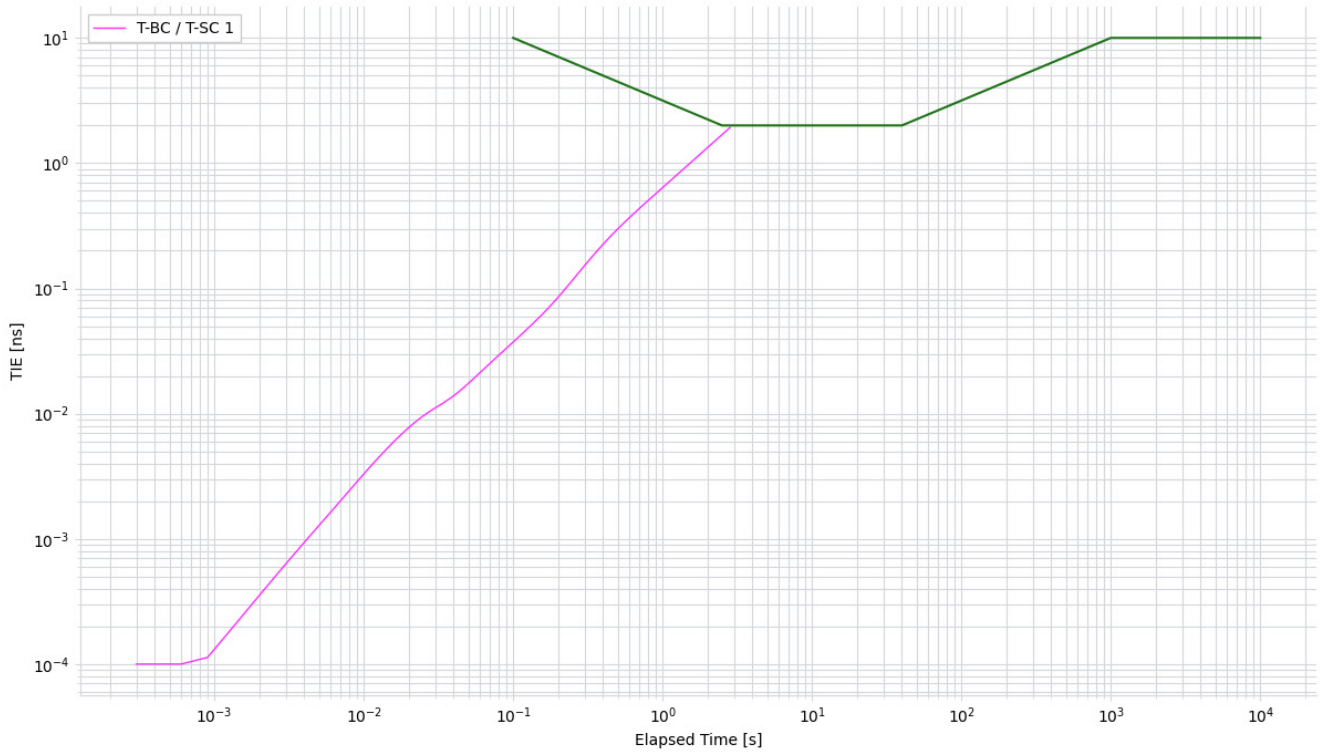

Figure 111. Short-term Phase Transient Response – G.8262 EEC Option 2, 0.1Hz – TDEV

	T-BC / T-SC 1
Min [ns]	0.0
Max [ns]	1.928
Max-Min [ns]	1.928

7.3.4. Short-term Phase Transient Response – G.8262.1 eEEC, 3Hz

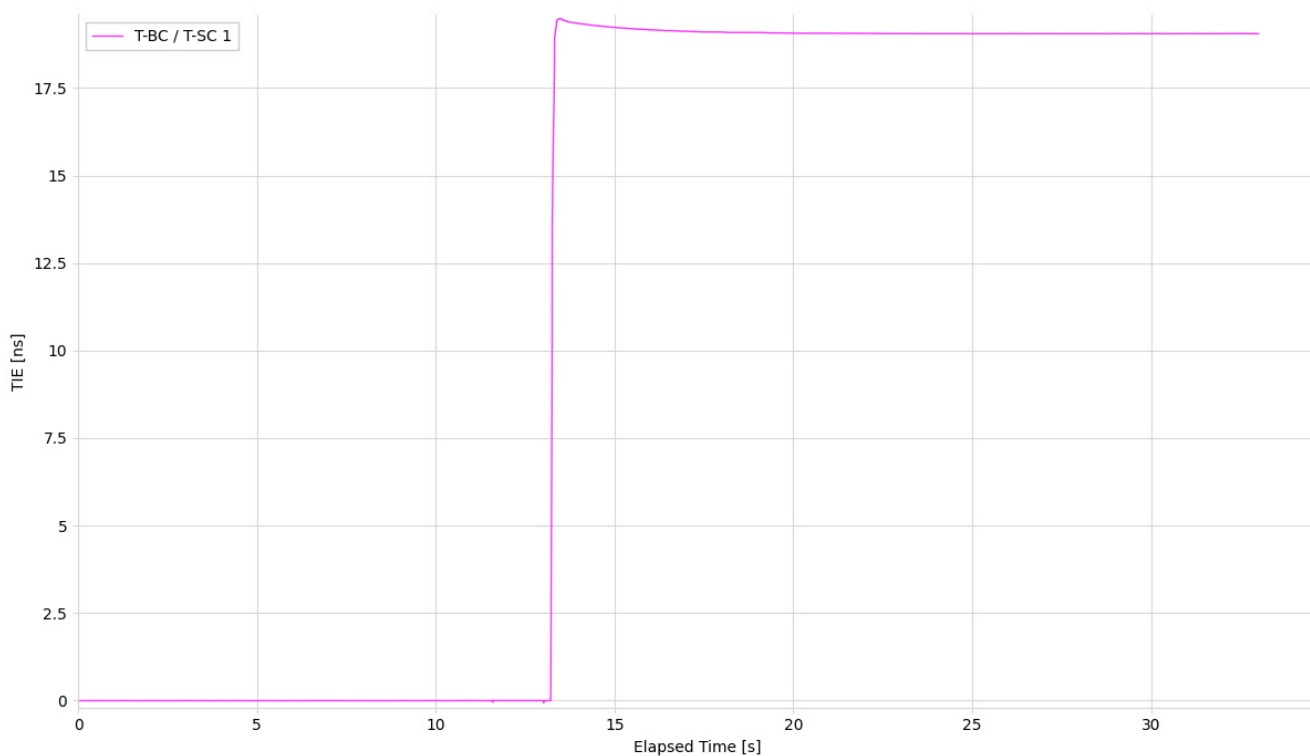

Figure 112. Short-term Phase Transient Response – G.8262.1 eEEC, 3Hz – TIE (no mask)

	T-BC / T-SC 1
Mean [ns]	11.425
Min [ns]	-0.065
Max [ns]	19.486
Max-Min [ns]	19.551

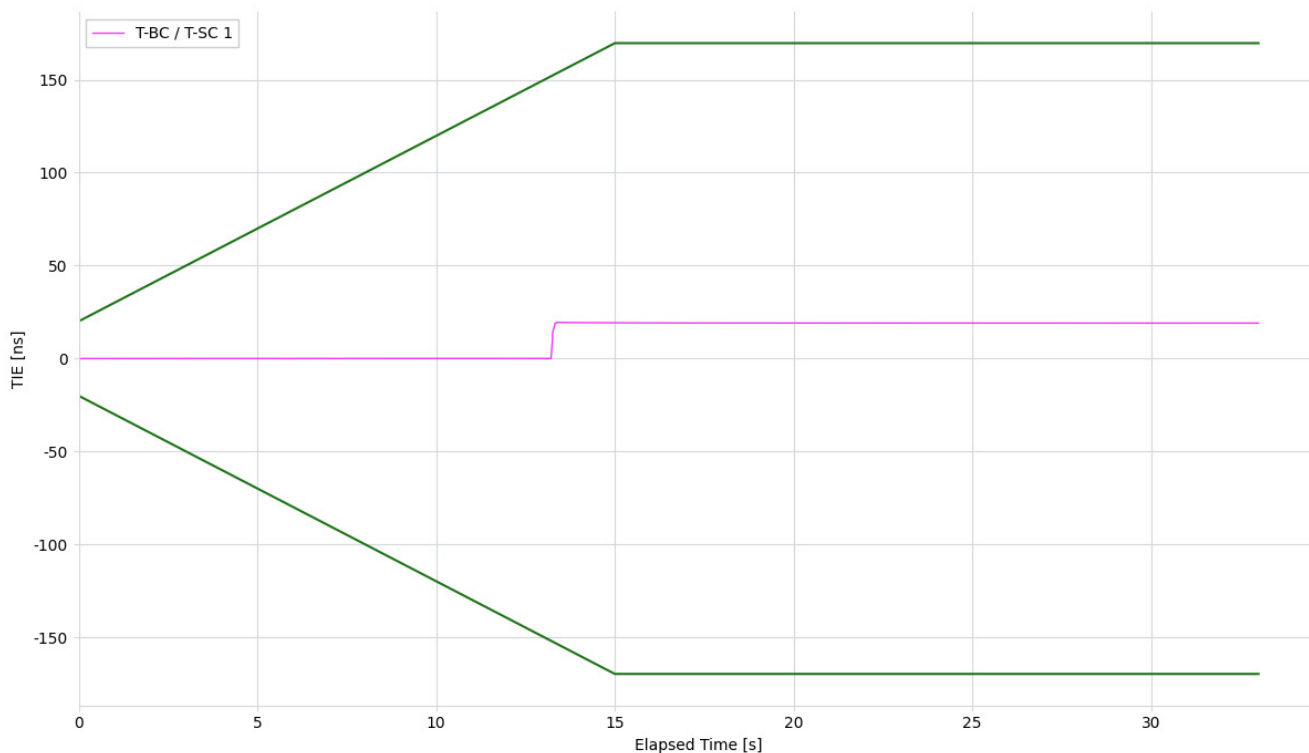

Figure 113. Short-term Phase Transient Response – G.8262.1 eEEC, 3Hz – TIE

	T-BC / T-SC 1
Mean [ns]	11.425
Min [ns]	-0.065
Max [ns]	19.486
Max-Min [ns]	19.551

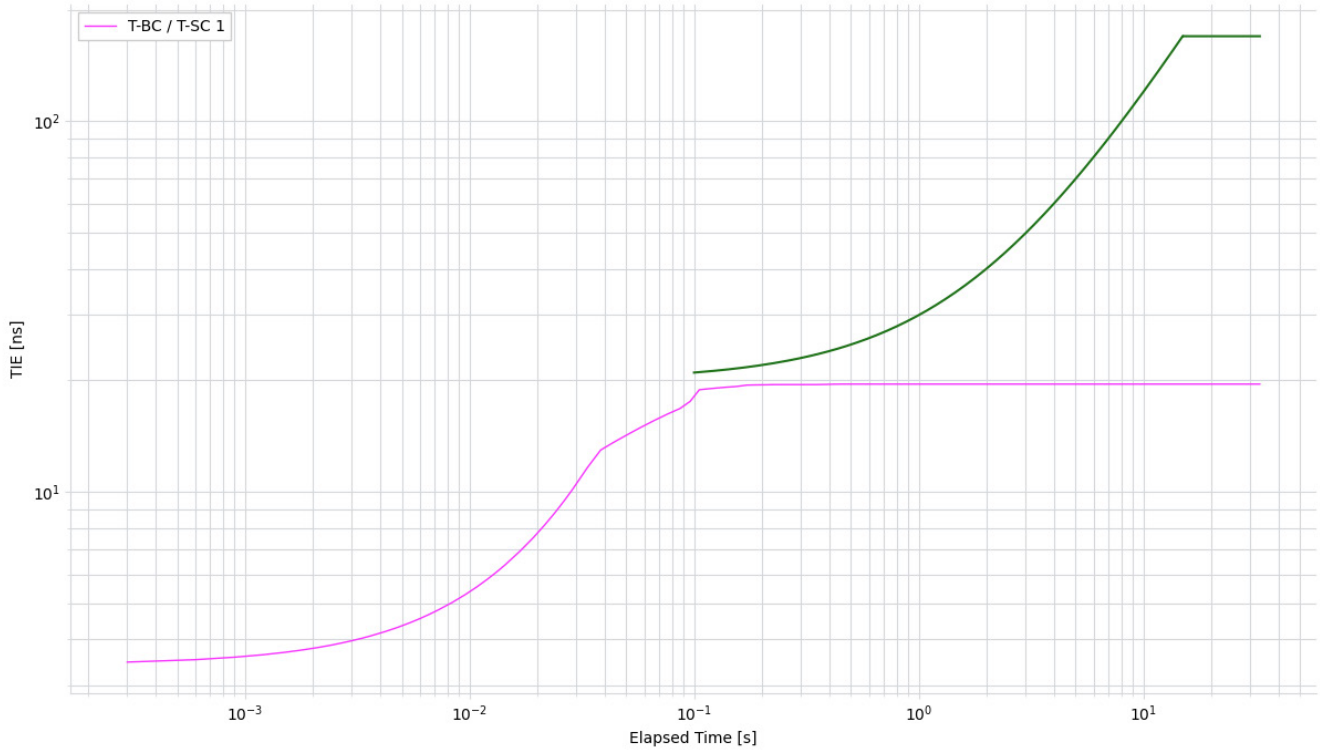

Figure 114. Short-term Phase Transient Response – G.8262.1 eEEC, 3Hz – MTIE

	T-BC / T-SC 1
Min [ns]	3.477
Max [ns]	19.551
Max-Min [ns]	16.074

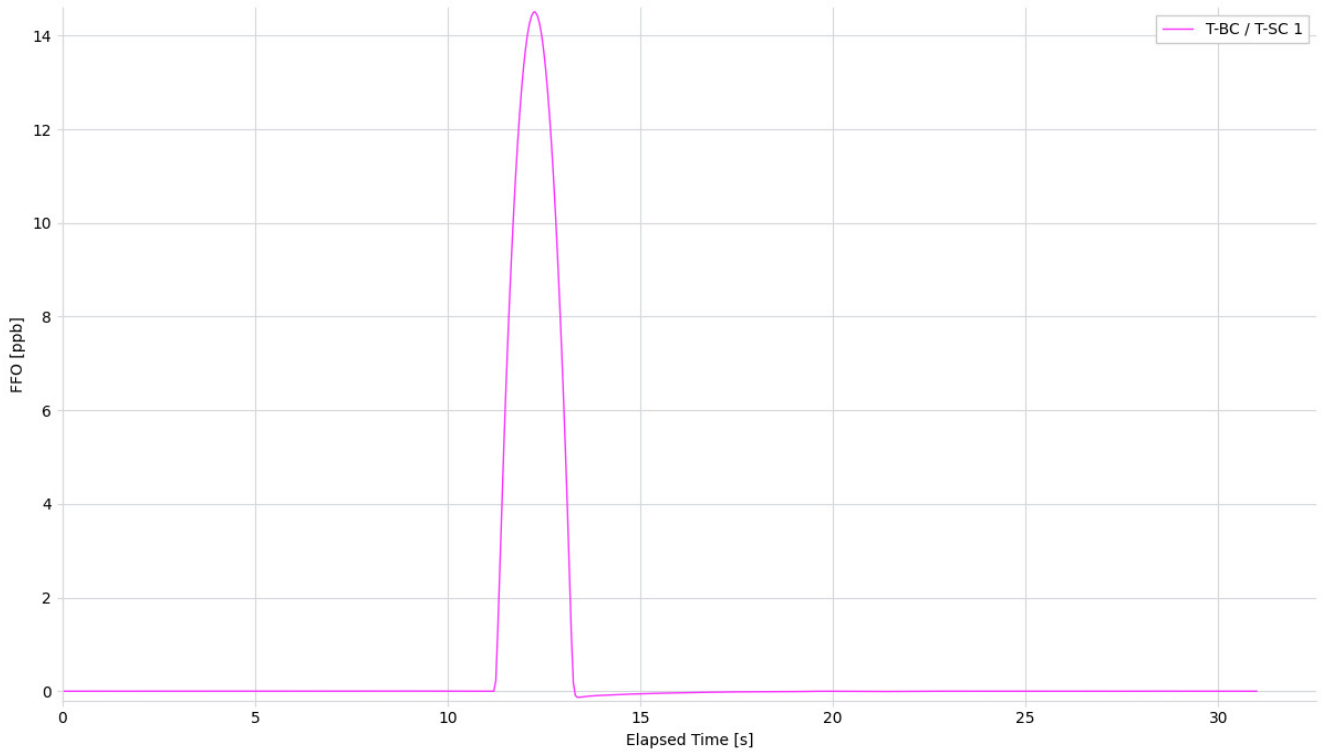

Figure 115. Short-term Phase Transient Response – G.8262.1 eEEC, 3Hz – FFO

	T-BC / T-SC 1
Mean [ppb]	0.614
Min [ppb]	-0.132
Max [ppb]	14.508
Max-Min [ppb]	14.64

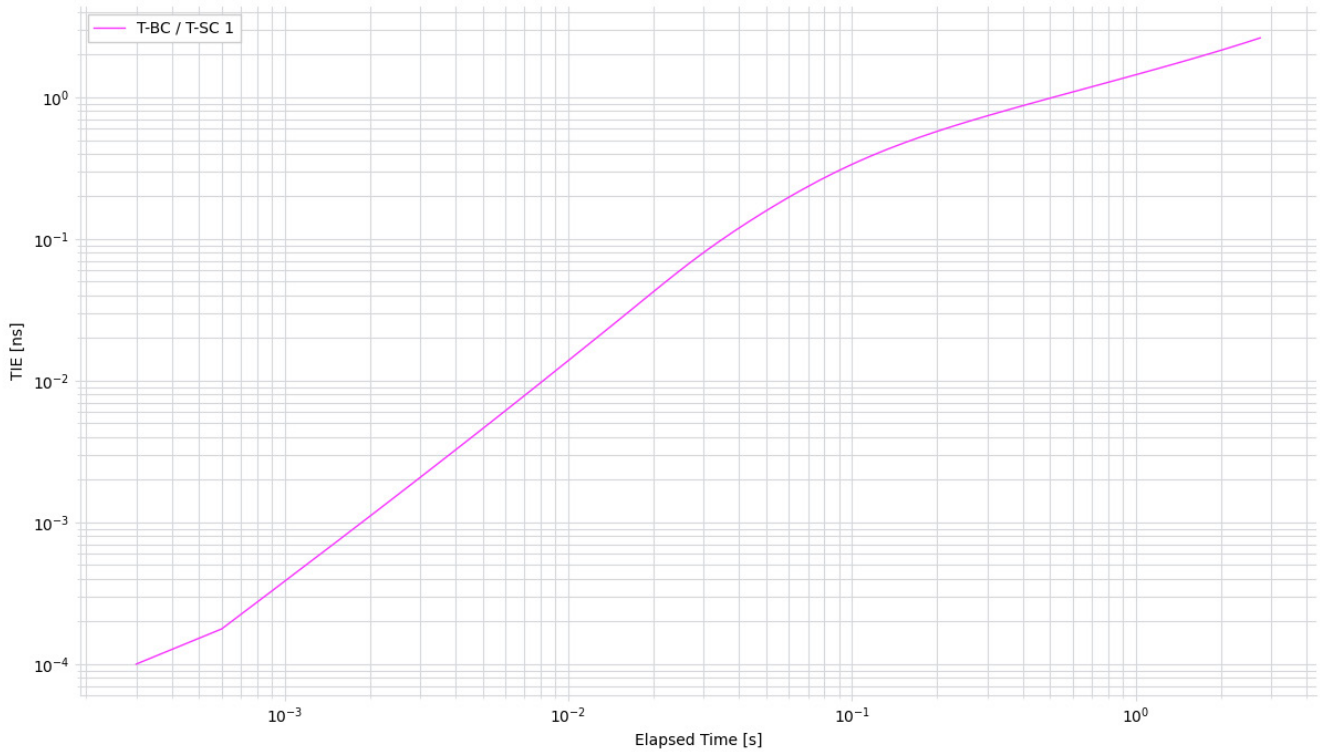

Figure 116. Short-term Phase Transient Response – G.8262.1 eEEC, 3Hz – TDEV

	T-BC / T-SC 1
Min [ns]	0.0
Max [ns]	2.629
Max-Min [ns]	2.629

8. Wander Generation

The wander generation requirement checks for the noise generated by the DUT, and while the PLL is locked to an input clock signal that is wander free, it should not generate any wander exceeding the MTIE mask given by the applicable standard (see Figure 1 for the equipment configuration).

The wander generation is carried out by providing a reference clock from the Frequency Generator on IN_A. The PLL should not produce/add any wander to the output beyond standard allowed value. The test is run for 2 hours. The output from the DUT is available on OUT_0 and the phase time error is captured using the Frequency Counter.

8.1 Wander Generation – G.8262 EEC Option 1, 1.2Hz

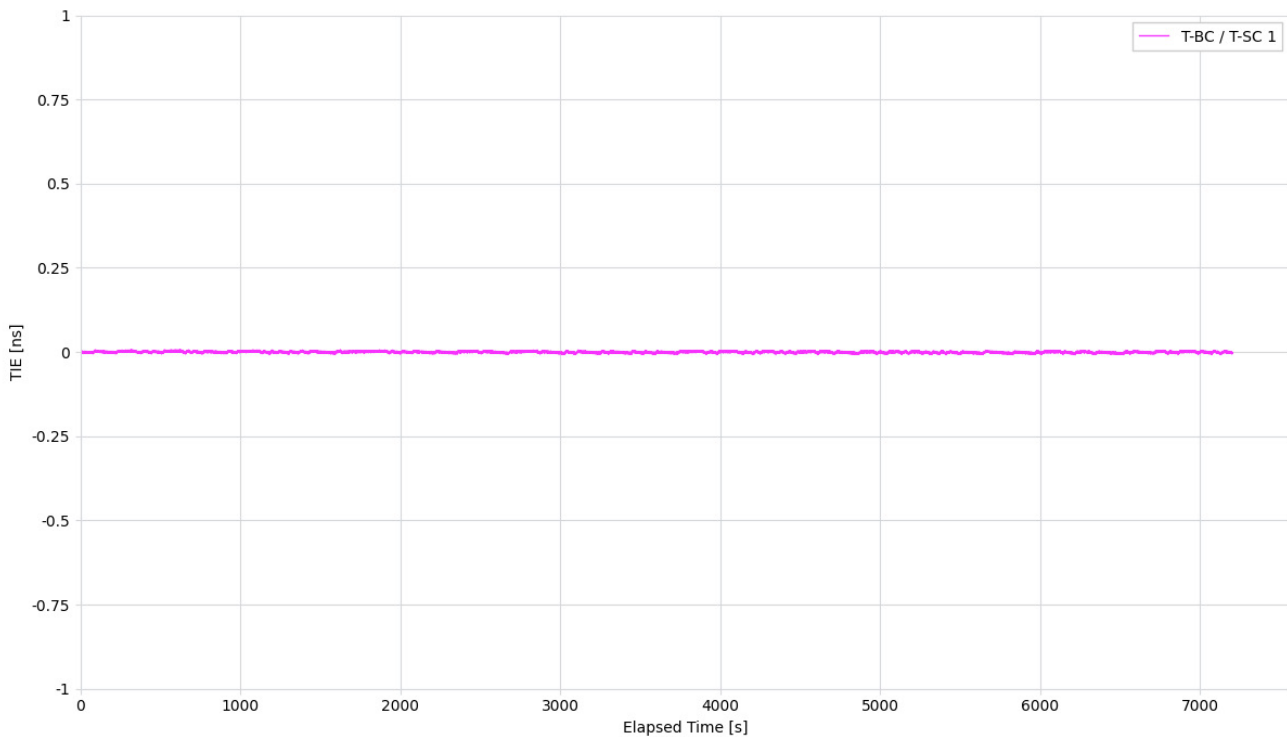

Figure 117. Wander Generation – G.8262 EEC Option 1, 1.2Hz – TIE

	T-BC / T-SC 1
Mean [ns]	-0.0
Min [ns]	-0.008
Max [ns]	0.007
Max-Min [ns]	0.015

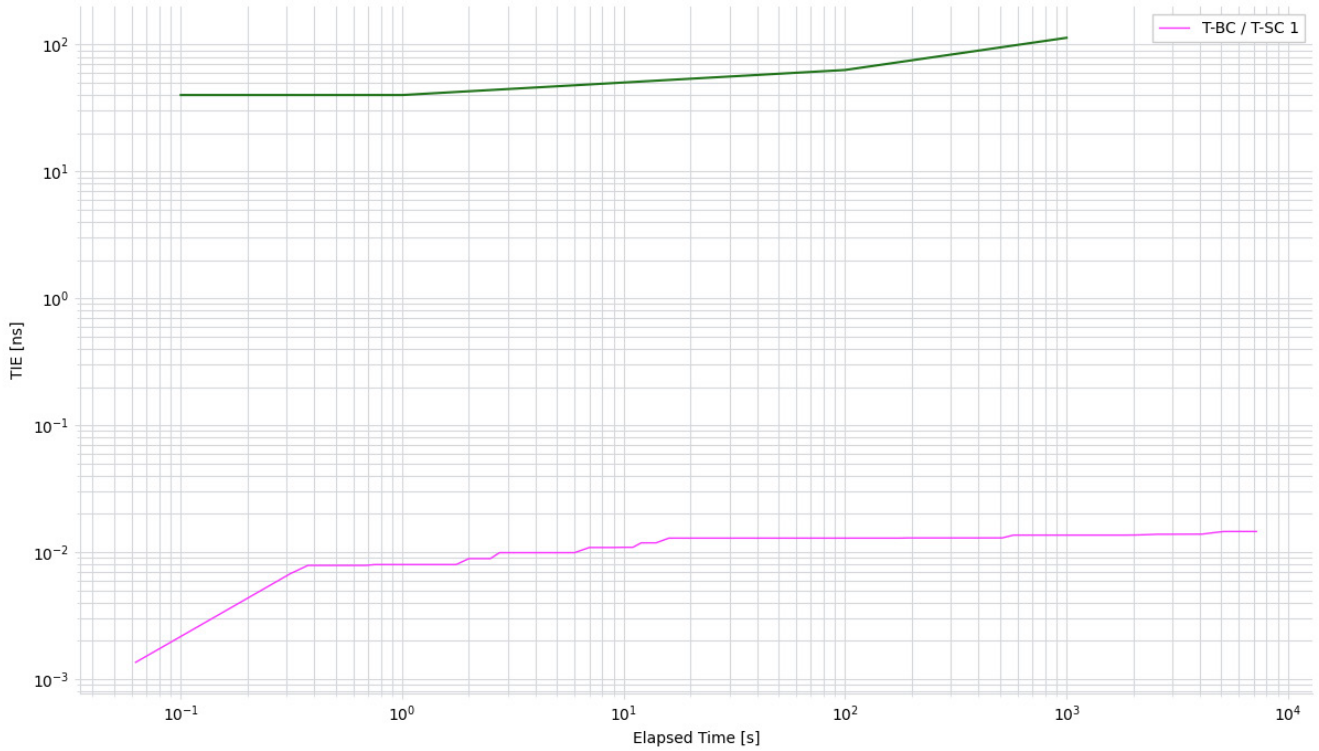

Figure 118. Wander Generation – G.8262 EEC Option 1, 1.2Hz – MTIE

	T-BC / T-SC 1
Min [ns]	0.001
Max [ns]	0.015
Max-Min [ns]	0.013

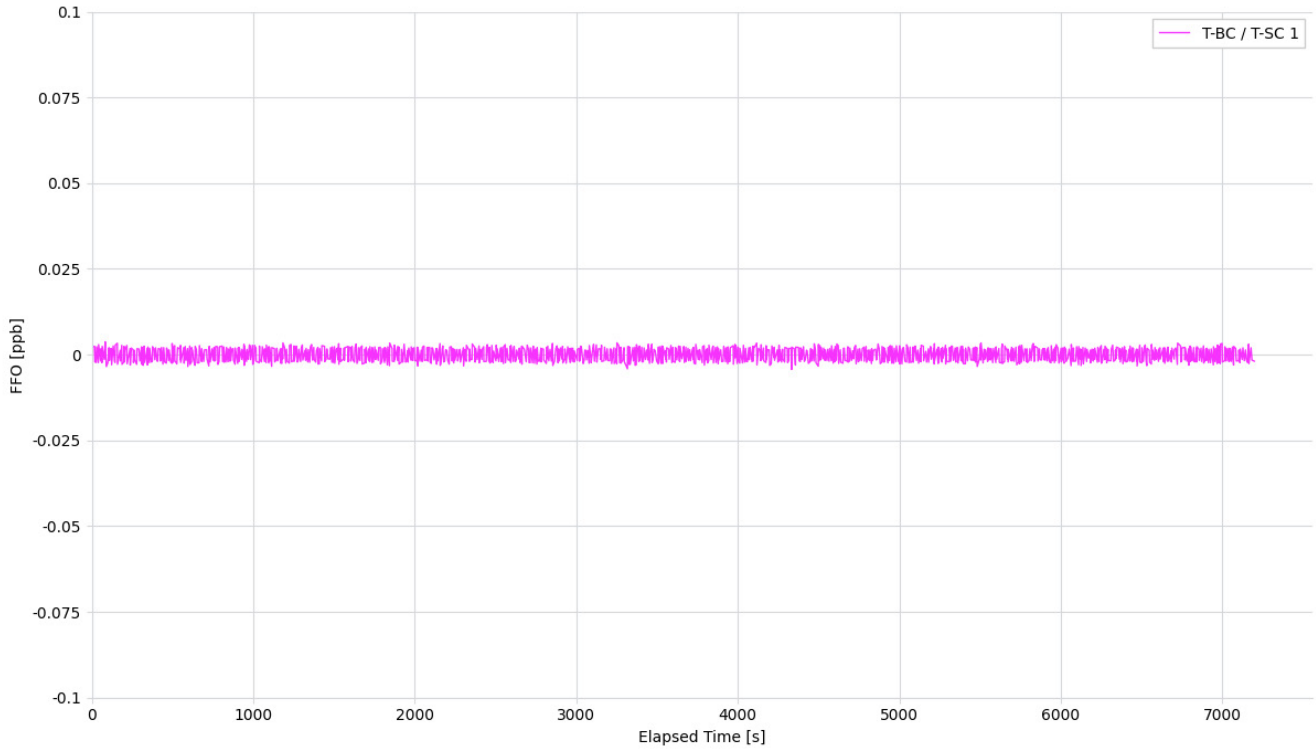

Figure 119. Wander Generation – G.8262 EEC Option 1, 1.2Hz – FFO

	T-BC / T-SC 1
Mean [ppb]	-0.0
Min [ppb]	-0.004
Max [ppb]	0.004
Max-Min [ppb]	0.008

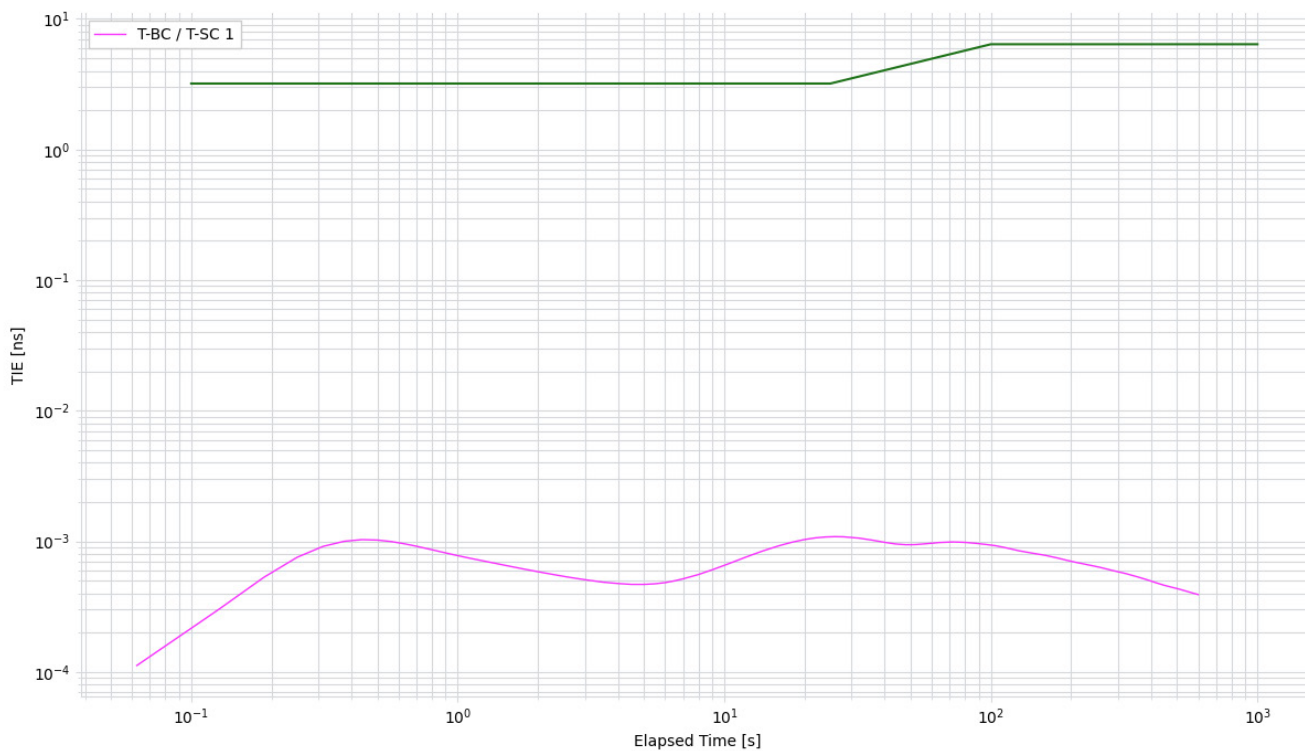

Figure 120. Wander Generation – G.8262 EEC Option 1, 1.2Hz – TDEV

	T-BC / T-SC 1
Min [ns]	0.0
Max [ns]	0.001
Max-Min [ns]	0.001

8.2 Wander Generation – G.8262 EEC Option 1, 10Hz

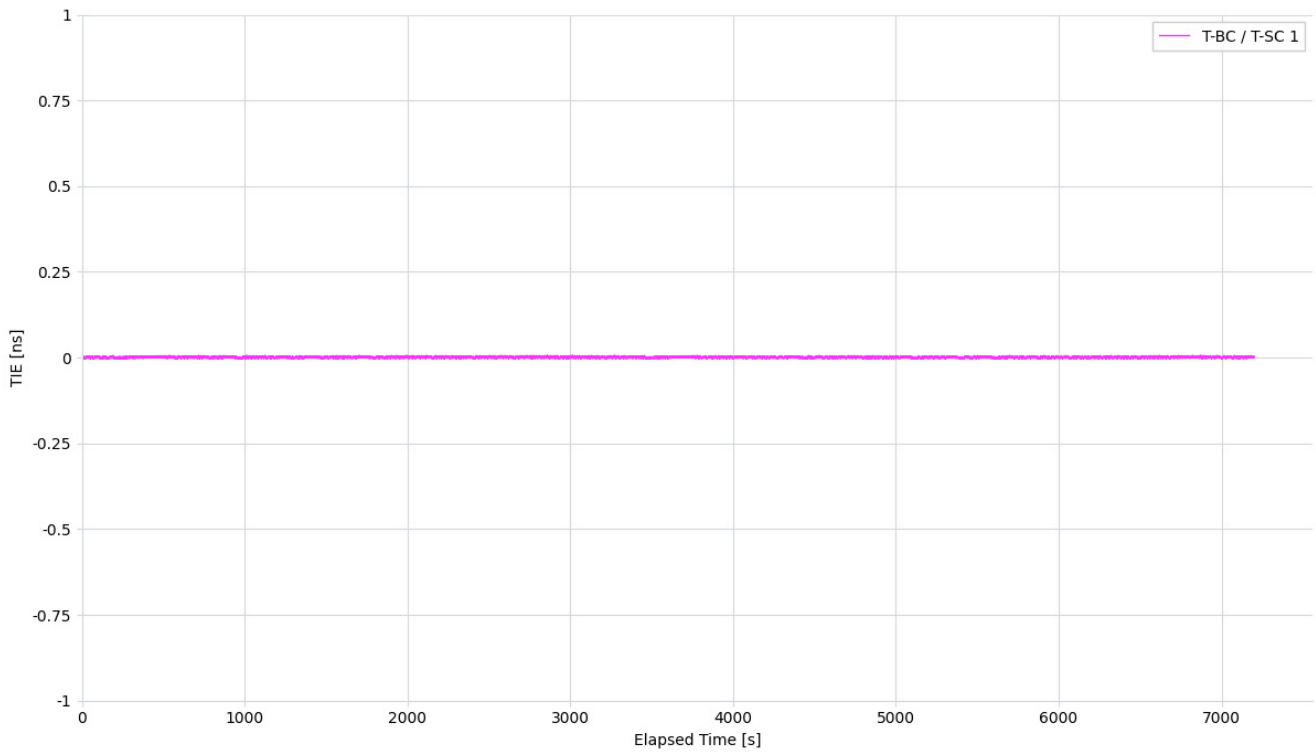

Figure 121. Wander Generation – G.8262 EEC Option 1, 10Hz – TIE

	T-BC / T-SC 1
Mean [ns]	0.001
Min [ns]	-0.005
Max [ns]	0.007
Max-Min [ns]	0.012

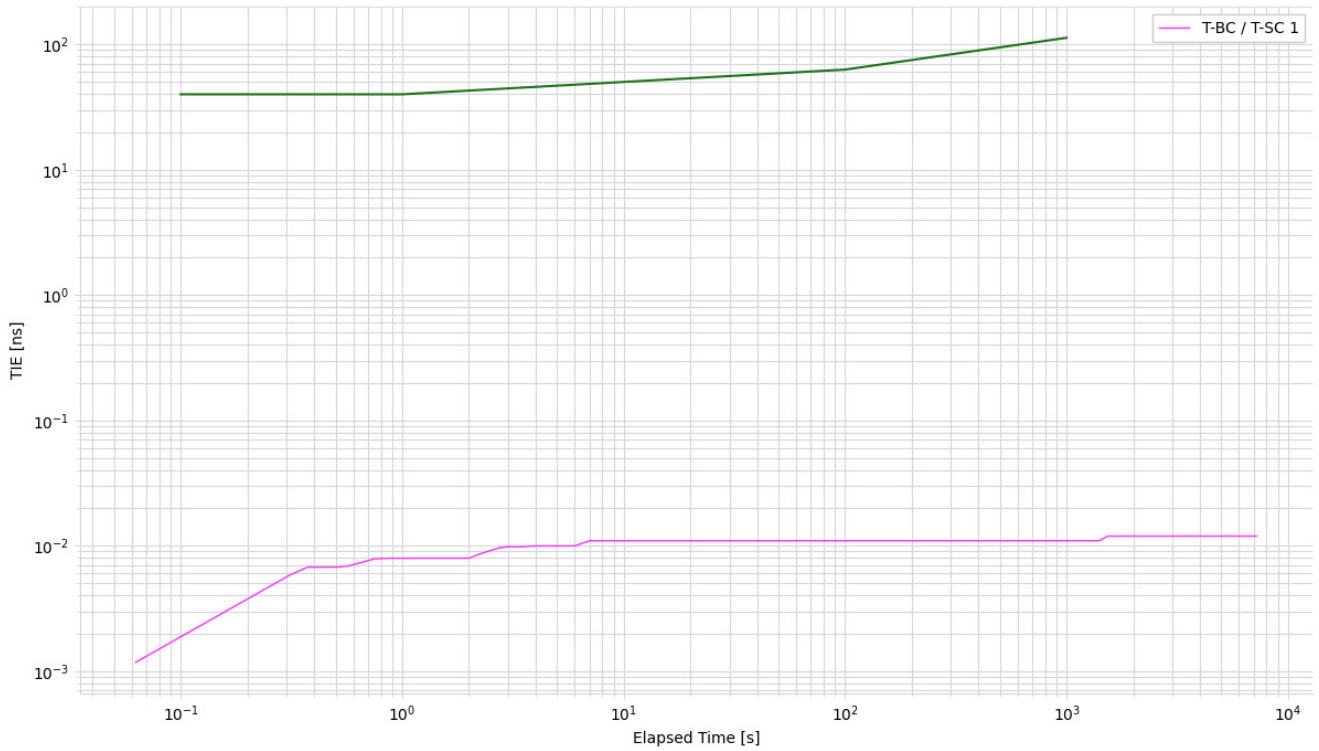

Figure 122. Wander Generation – G.8262 EEC Option 1, 10Hz – MTIE

	T-BC / T-SC 1
Min [ns]	0.001
Max [ns]	0.012
Max-Min [ns]	0.011

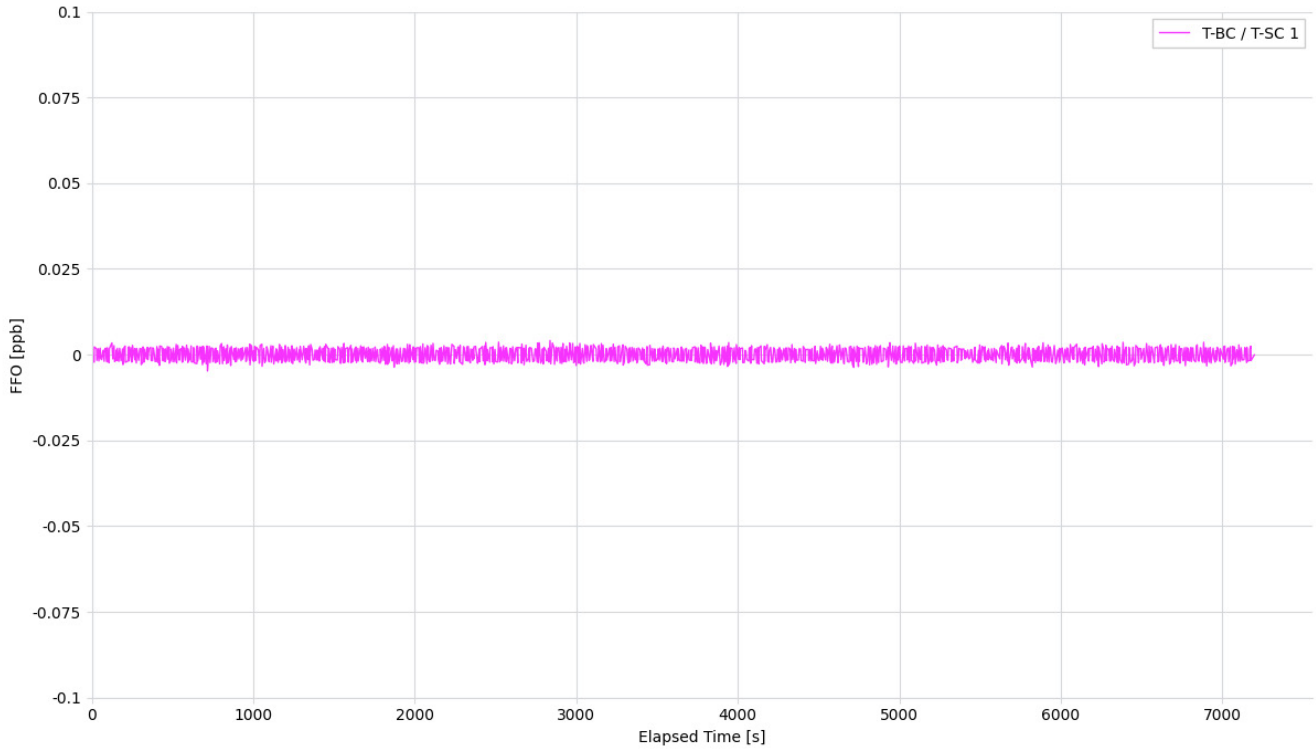

Figure 123. Wander Generation – G.8262 EEC Option 1, 10Hz – FFO

	T-BC / T-SC 1
Mean [ppb]	0.0
Min [ppb]	-0.005
Max [ppb]	0.004
Max-Min [ppb]	0.009

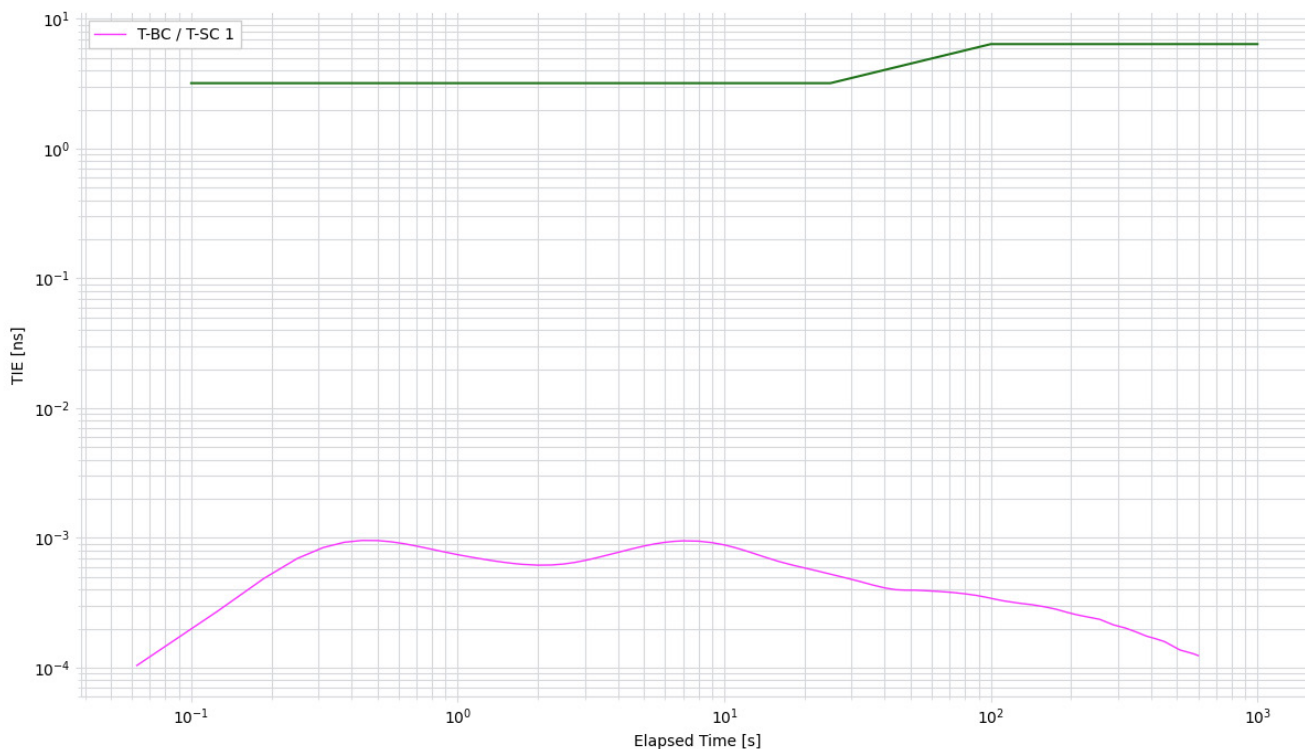

Figure 124. Wander Generation – G.8262 EEC Option 1, 10Hz – TDEV

	T-BC / T-SC 1
Min [ns]	0.0
Max [ns]	0.001
Max-Min [ns]	0.001

8.3 Wander Generation – G.8262 EEC Option 2, 0.1Hz

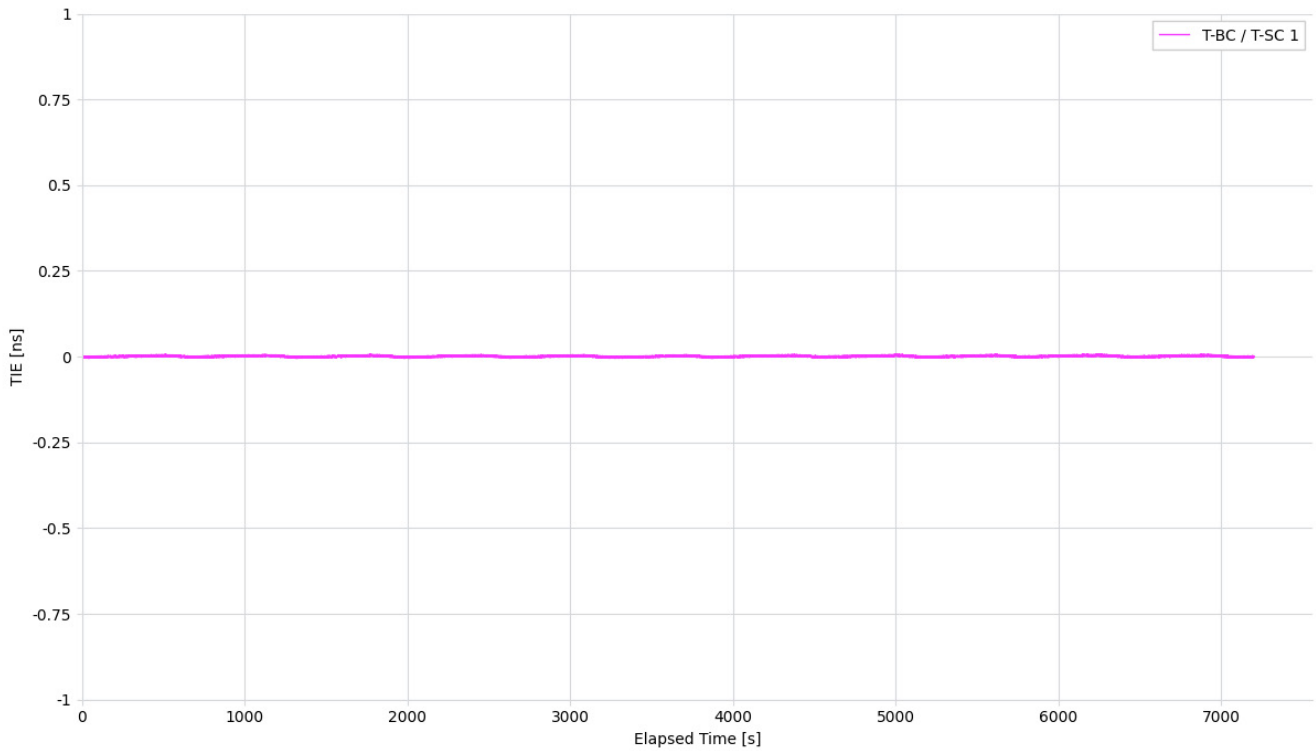

Figure 125. Wander Generation – G.8262 EEC Option 2, 0.1Hz – TIE

	T-BC / T-SC 1
Mean [ns]	0.001
Min [ns]	-0.005
Max [ns]	0.007
Max-Min [ns]	0.012

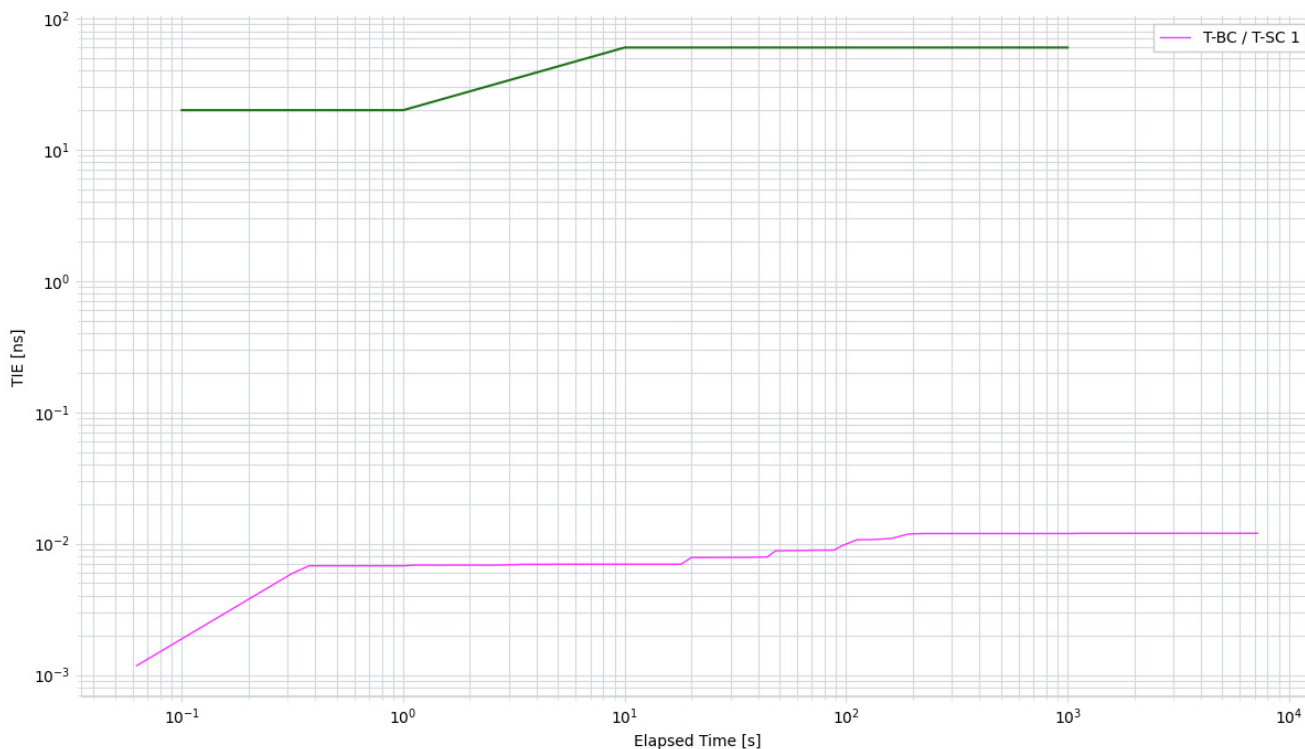

Figure 126. Wander Generation – G.8262 EEC Option 2, 0.1Hz – MTIE

	T-BC / T-SC 1
Min [ns]	0.001
Max [ns]	0.012
Max-Min [ns]	0.011

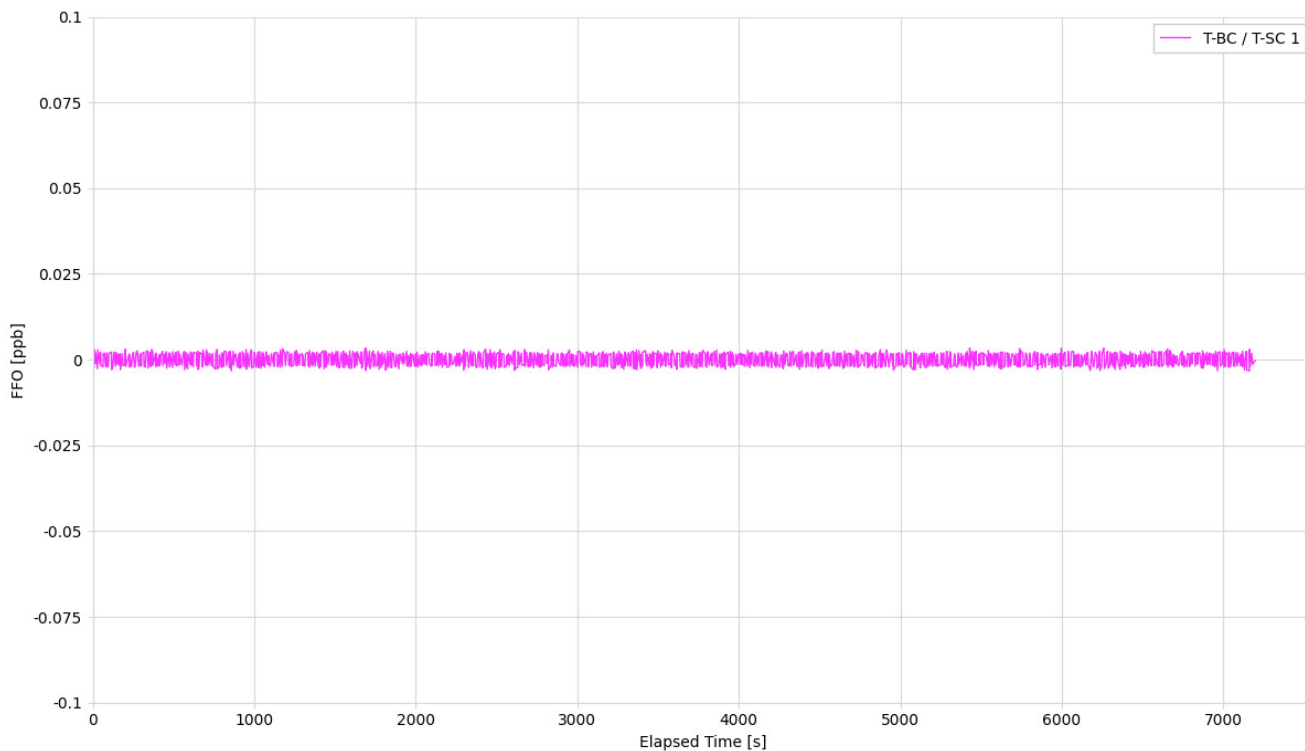

Figure 127. Wander Generation – G.8262 EEC Option 2, 0.1Hz – FFO

	T-BC / T-SC 1
Mean [ppb]	0.0
Min [ppb]	-0.003
Max [ppb]	0.003
Max-Min [ppb]	0.007

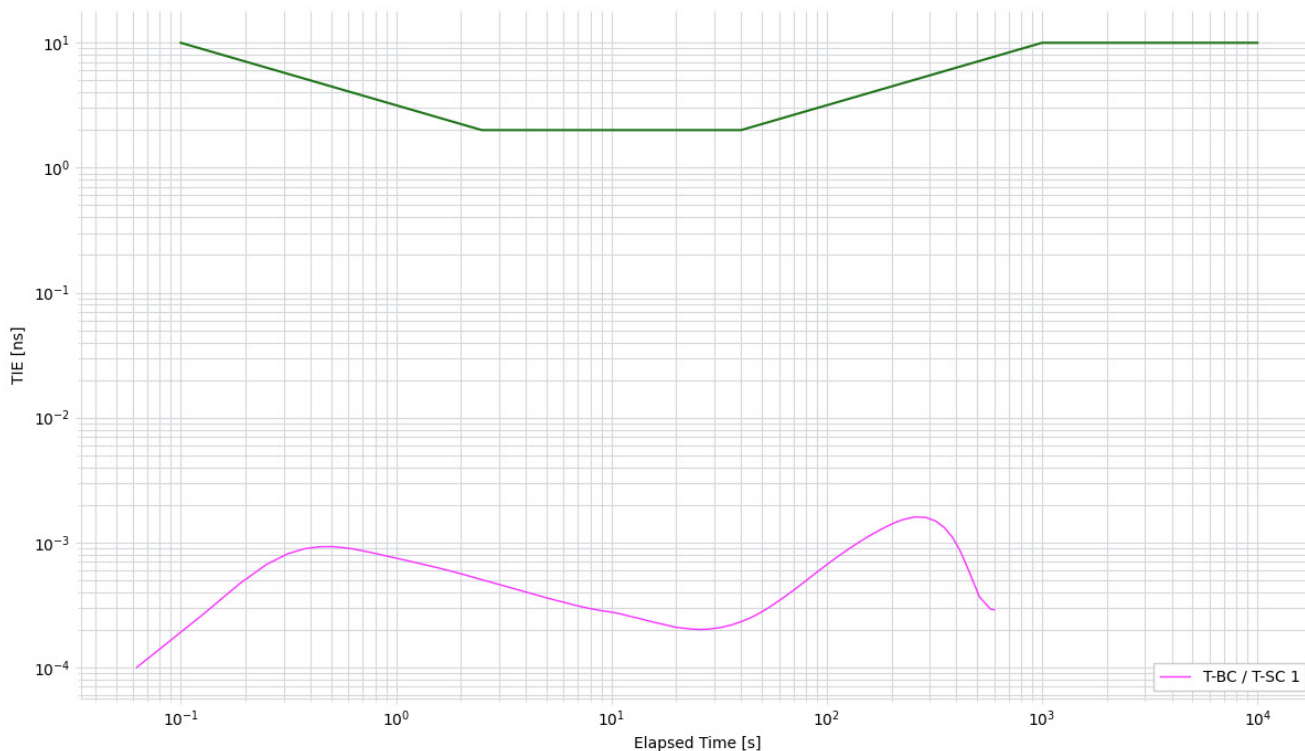

Figure 128. Wander Generation – G.8262 EEC Option 2, 0.1Hz – TDEV

	T-BC / T-SC 1
Min [ns]	0.0
Max [ns]	0.002
Max-Min [ns]	0.002

8.4 Wander Generation – G.8262.1 eEEC, 3Hz

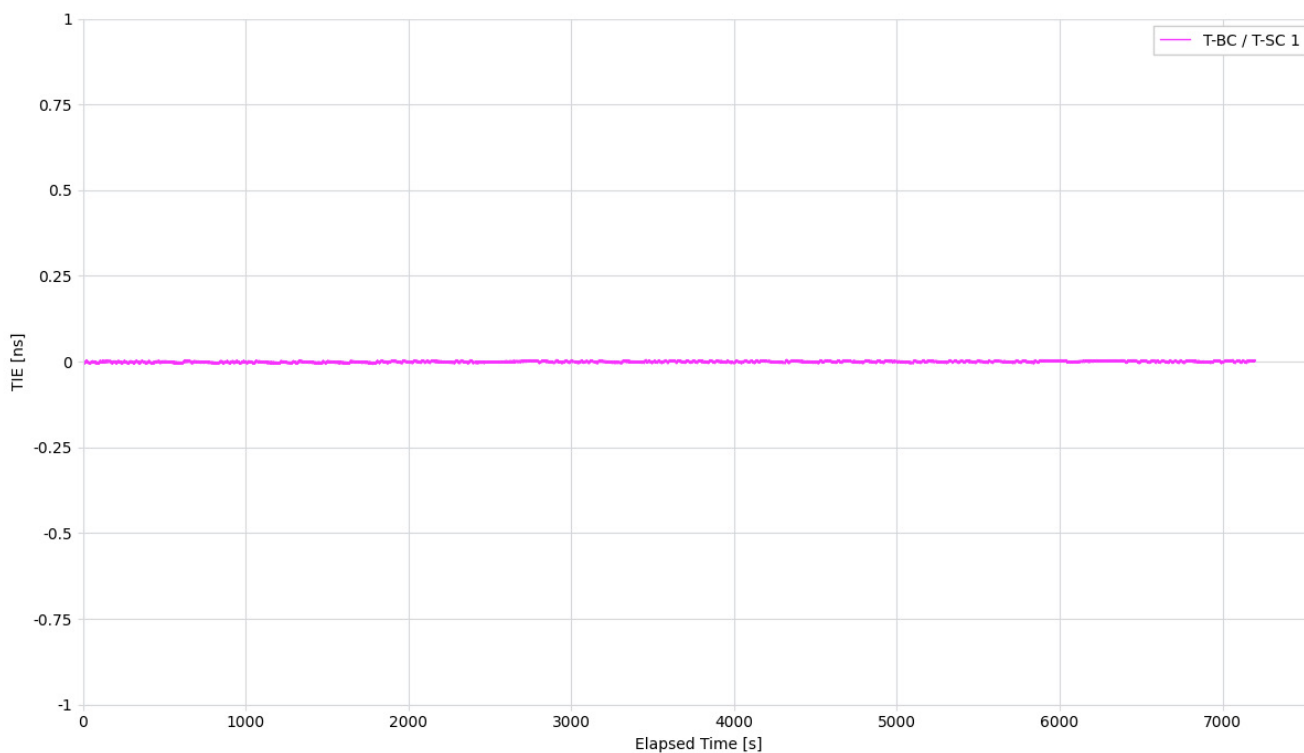

Figure 129. Wander Generation – G.8262.1 eEEC, 3Hz – TIE

	T-BC / T-SC 1
Mean [ns]	-0.0
Min [ns]	-0.008
Max [ns]	0.006
Max-Min [ns]	0.014

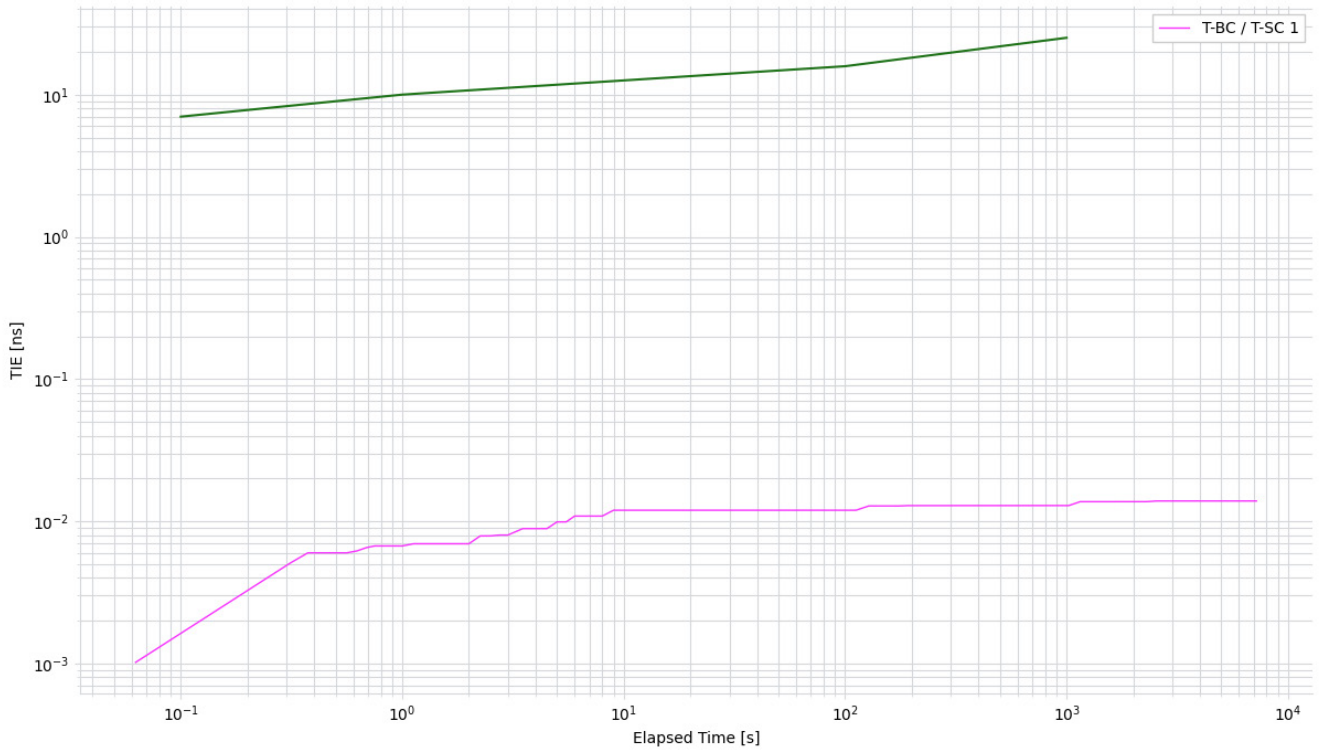

Figure 130. Wander Generation – G.8262.1 eEEC, 3Hz – MTIE

	T-BC / T-SC 1
Min [ns]	0.001
Max [ns]	0.014
Max-Min [ns]	0.013

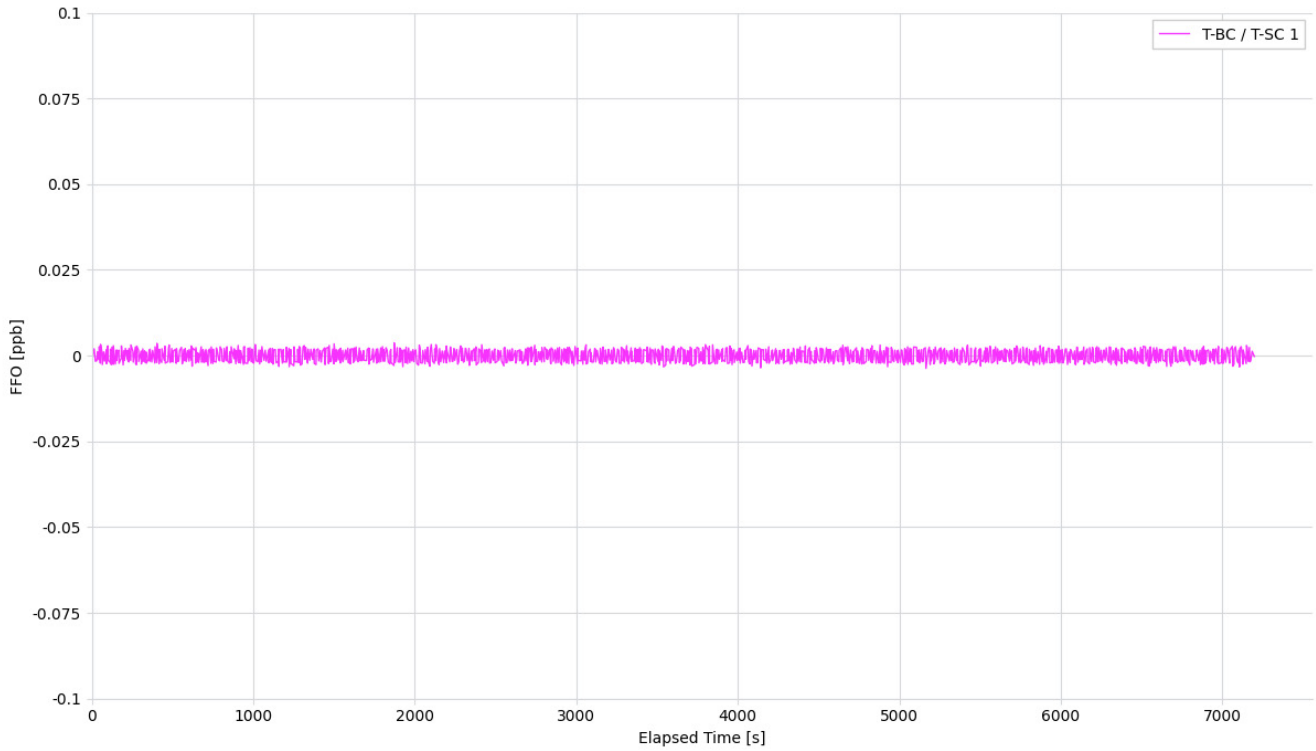

Figure 131. Wander Generation – G.8262.1 eEEC, 3Hz – FFO

	T-BC / T-SC 1
Mean [ppb]	-0.0
Min [ppb]	-0.004
Max [ppb]	0.004
Max-Min [ppb]	0.007

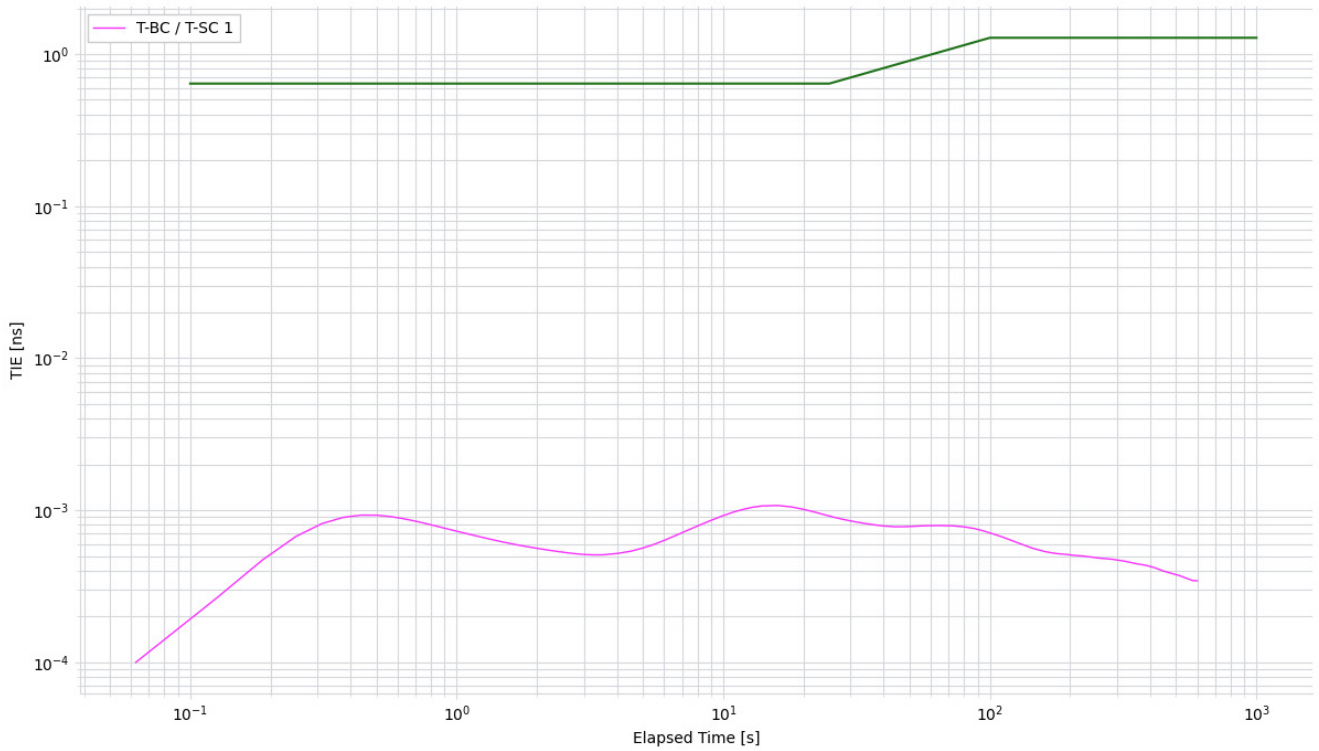

Figure 132. Wander Generation – G.8262.1 eEEC, 3Hz – TDEV

	T-BC / T-SC 1
Min [ns]	0.0
Max [ns]	0.001
Max-Min [ns]	0.001

9. Holdover

The holdover requirement checks for the phase time error after the loss of a clock input when the PLL is in holdover state. While in holdover, the PLL should produce phase time error that exceeds the phase time error requirements given by the applicable standard (see Figure 1 for the equipment configuration).

The holdover test is carried out by providing a reference clock from the Frequency Generator on IN_A. The PLL is locked to this wander-free reference for 2 hours. The input clock IN_A is then disabled for 40 minutes and the PLL goes into holdover state. The output from the DUT is available on OUT_0 and the phase time error is captured using the Frequency Counter.

9.1 Holdover – G.8262 EEC Option 1, 1.2Hz

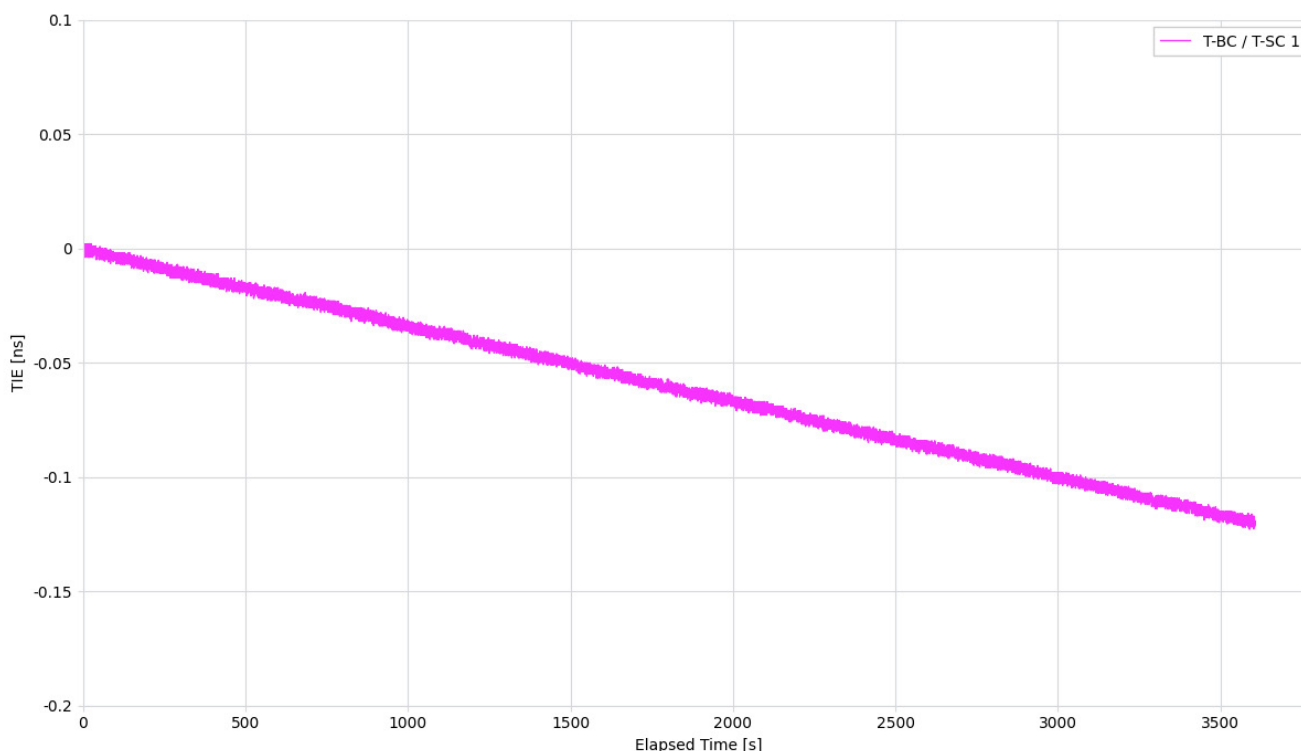

Figure 133. Holdover – G.8262 EEC Option 1, 1.2Hz – TIE (no mask)

	T-BC / T-SC 1
Mean [ns]	-0.06
Min [ns]	-0.123
Max [ns]	0.002
Max-Min [ns]	0.125

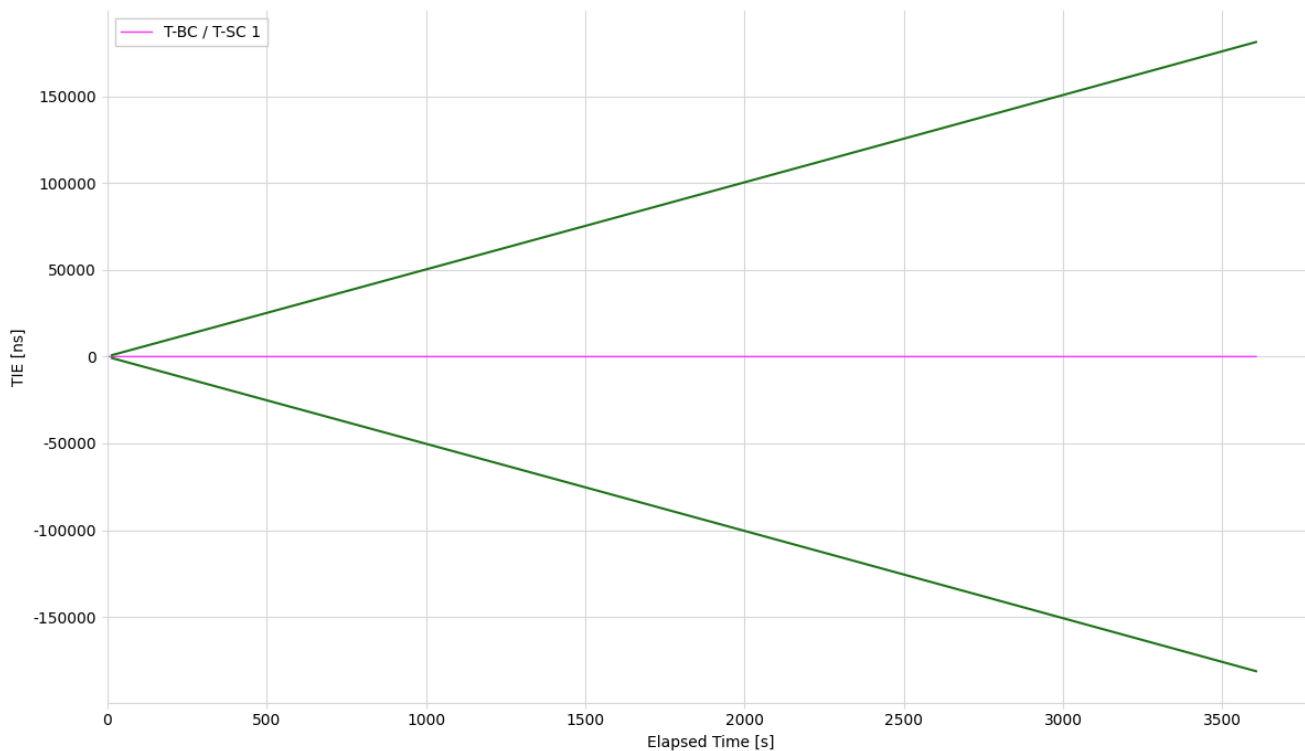

Figure 134. Holdover – G.8262 EEC Option 1, 1.2Hz – TIE

	T-BC / T-SC 1
Mean [ns]	-0.06
Min [ns]	-0.123
Max [ns]	0.002
Max-Min [ns]	0.125

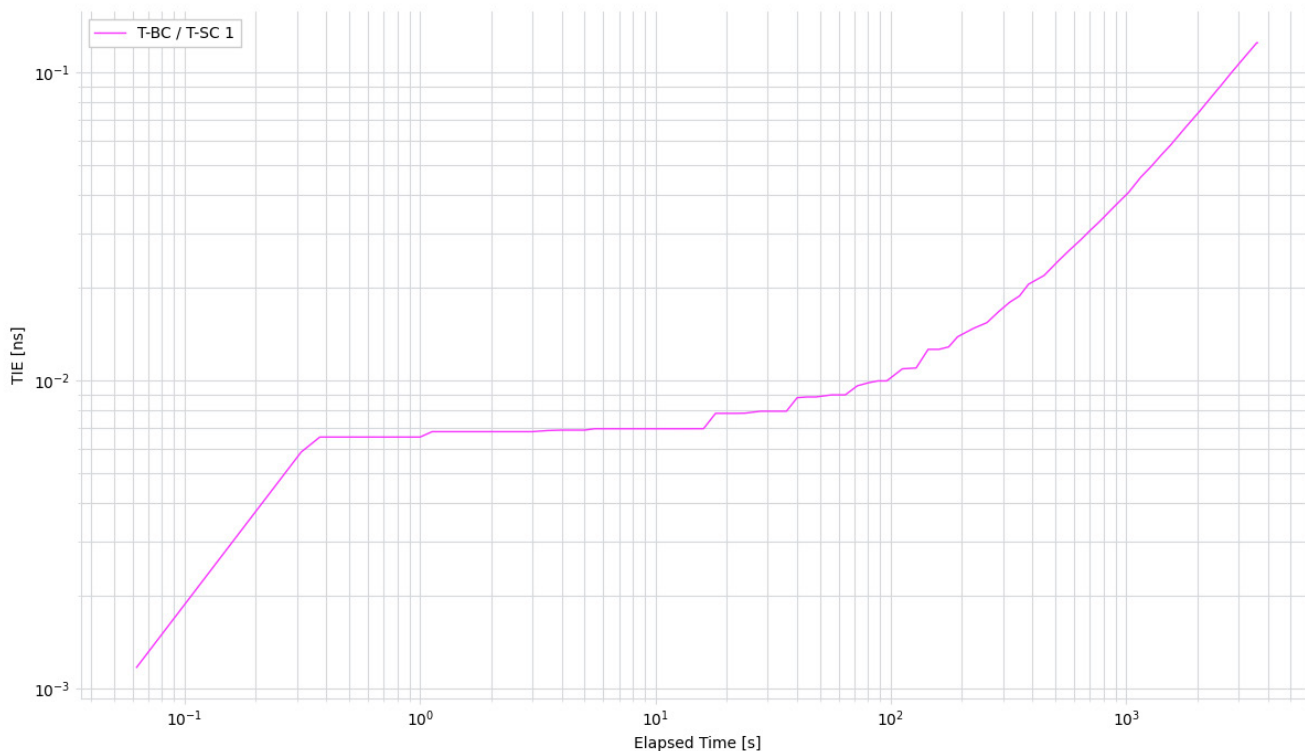

Figure 135. Holdover – G.8262 EEC Option 1, 1.2Hz – MTIE

	T-BC / T-SC 1
Min [ns]	0.001
Max [ns]	0.125
Max-Min [ns]	0.124

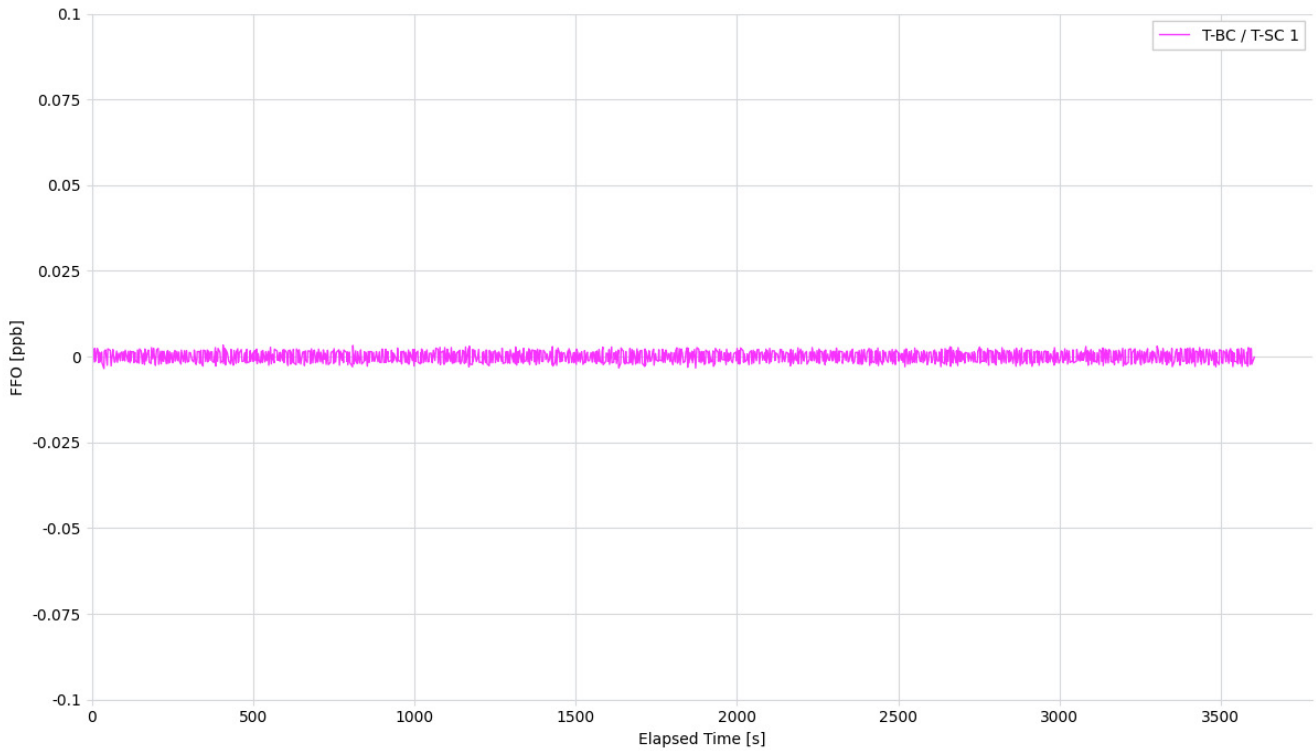

Figure 136. Holdover – G.8262 EEC Option 1, 1.2Hz – FFO

	T-BC / T-SC 1
Mean [ppb]	-0.0
Min [ppb]	-0.003
Max [ppb]	0.003
Max-Min [ppb]	0.007

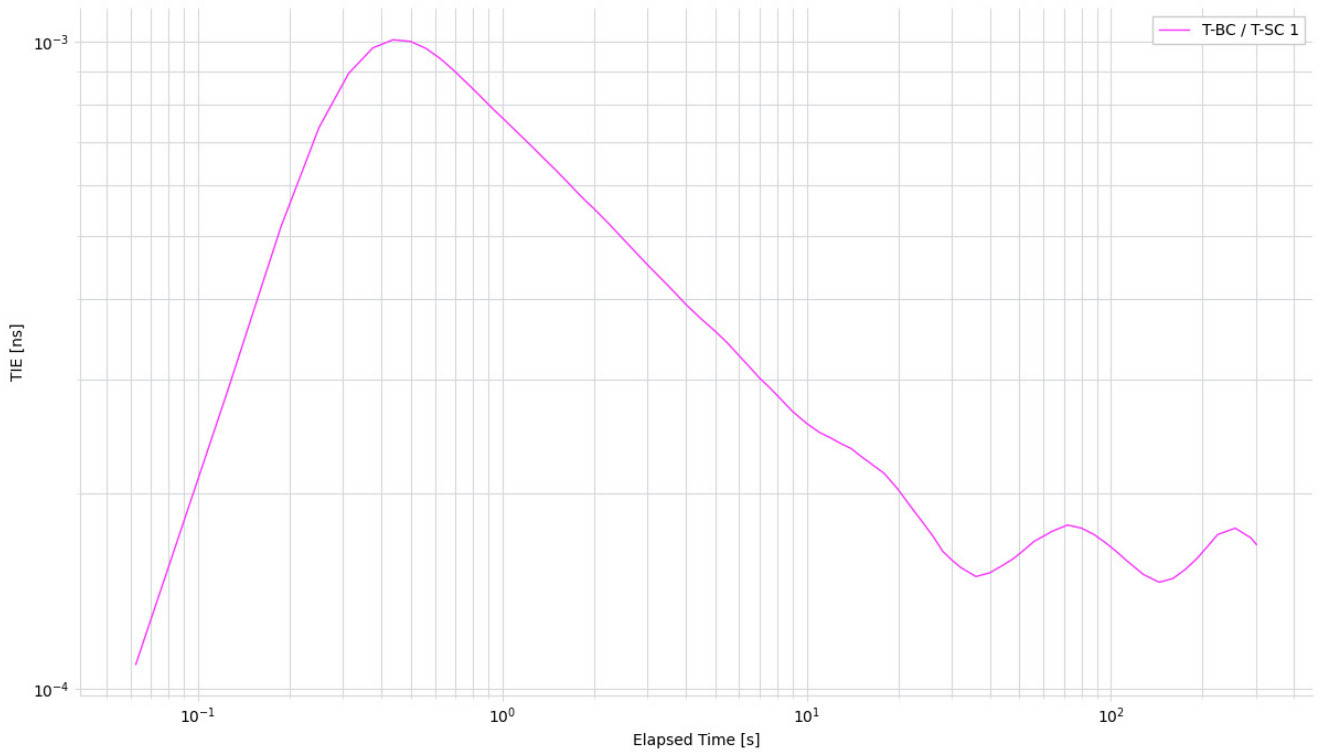

Figure 137. Holdover – G.8262 EEC Option 1, 1.2Hz – TDEV

	T-BC / T-SC 1
Min [ns]	0.0
Max [ns]	0.001
Max-Min [ns]	0.001

9.2 Holdover – G.8262 EEC Option 1, 10Hz

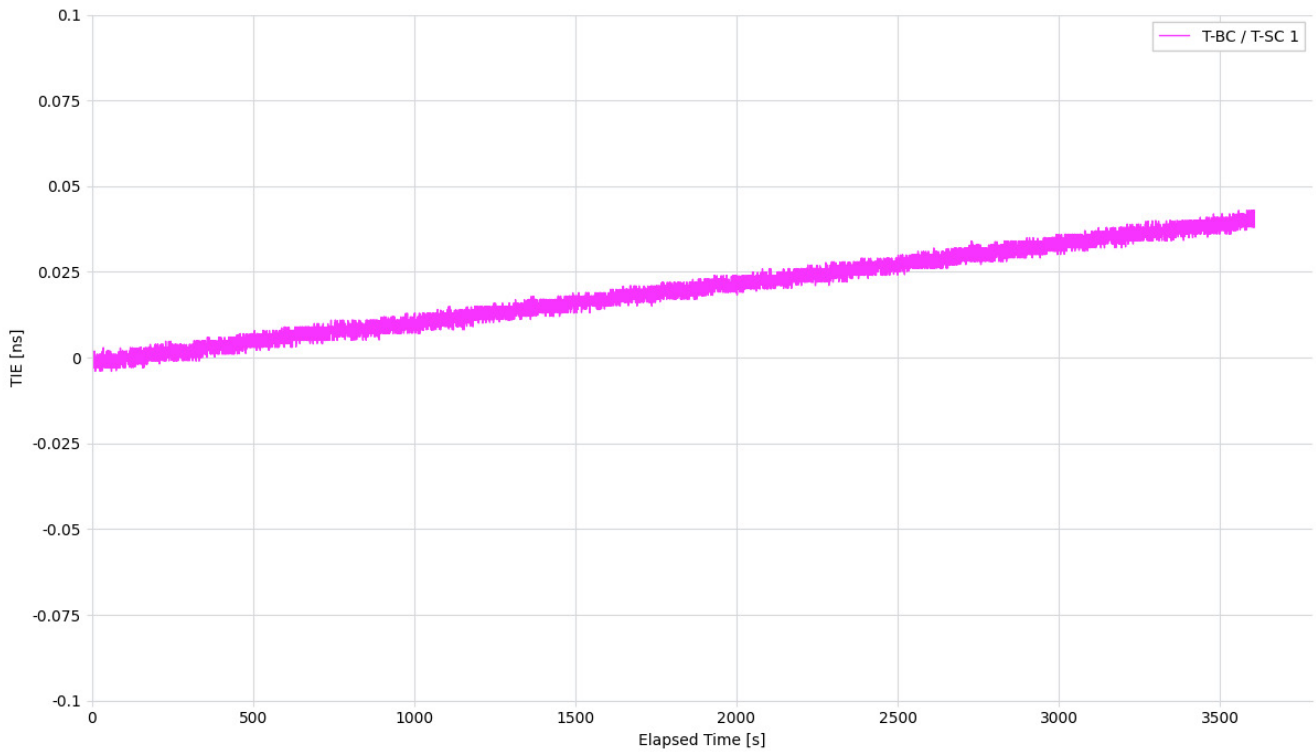

Figure 138. Holdover – G.8262 EEC Option 1, 10Hz

	T-BC / T-SC 1
Mean [ns]	0.019
Min [ns]	-0.004
Max [ns]	0.043
Max-Min [ns]	0.047



Figure 139. Holdover – G.8262 EEC Option 1, 10Hz – TIE

	T-BC / T-SC 1
Mean [ns]	0.019
Min [ns]	-0.004
Max [ns]	0.043
Max-Min [ns]	0.047

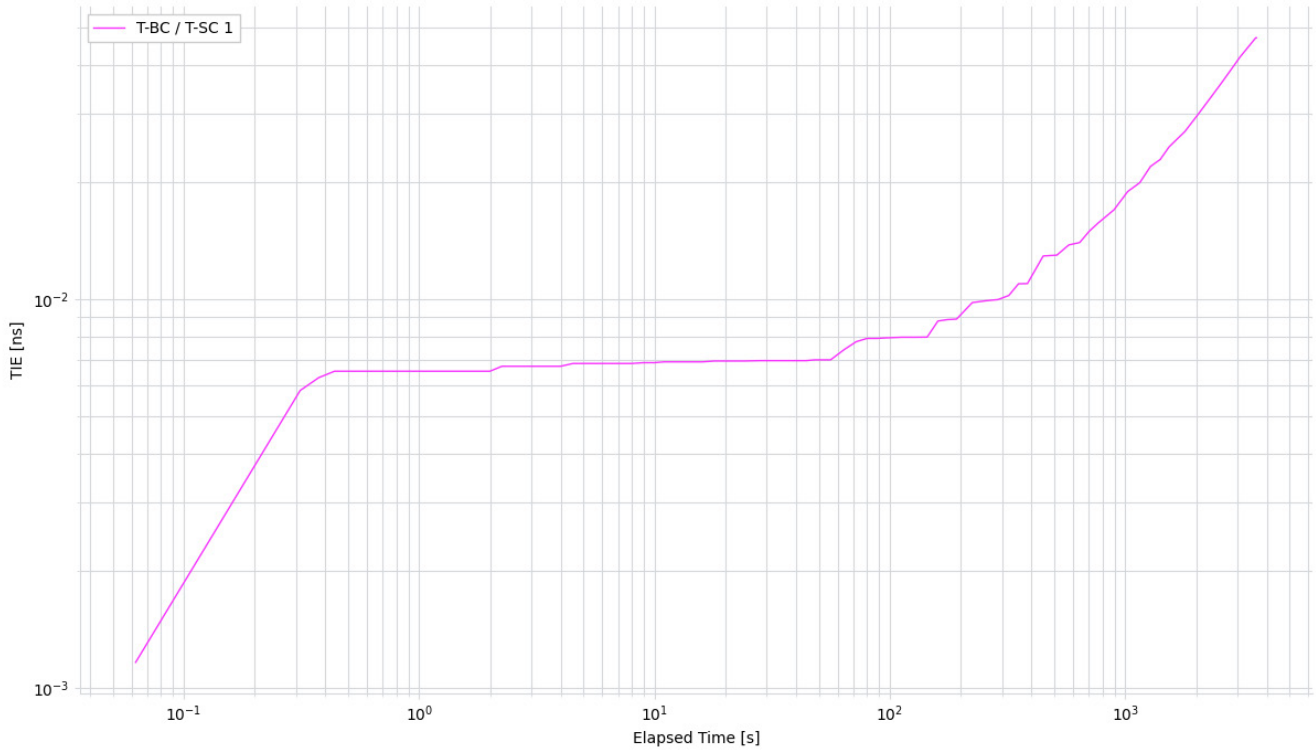

Figure 140. Holdover – G.8262 EEC Option 1, 10Hz – MTI

	T-BC / T-SC 1
Min [ns]	0.001
Max [ns]	0.047
Max-Min [ns]	0.046

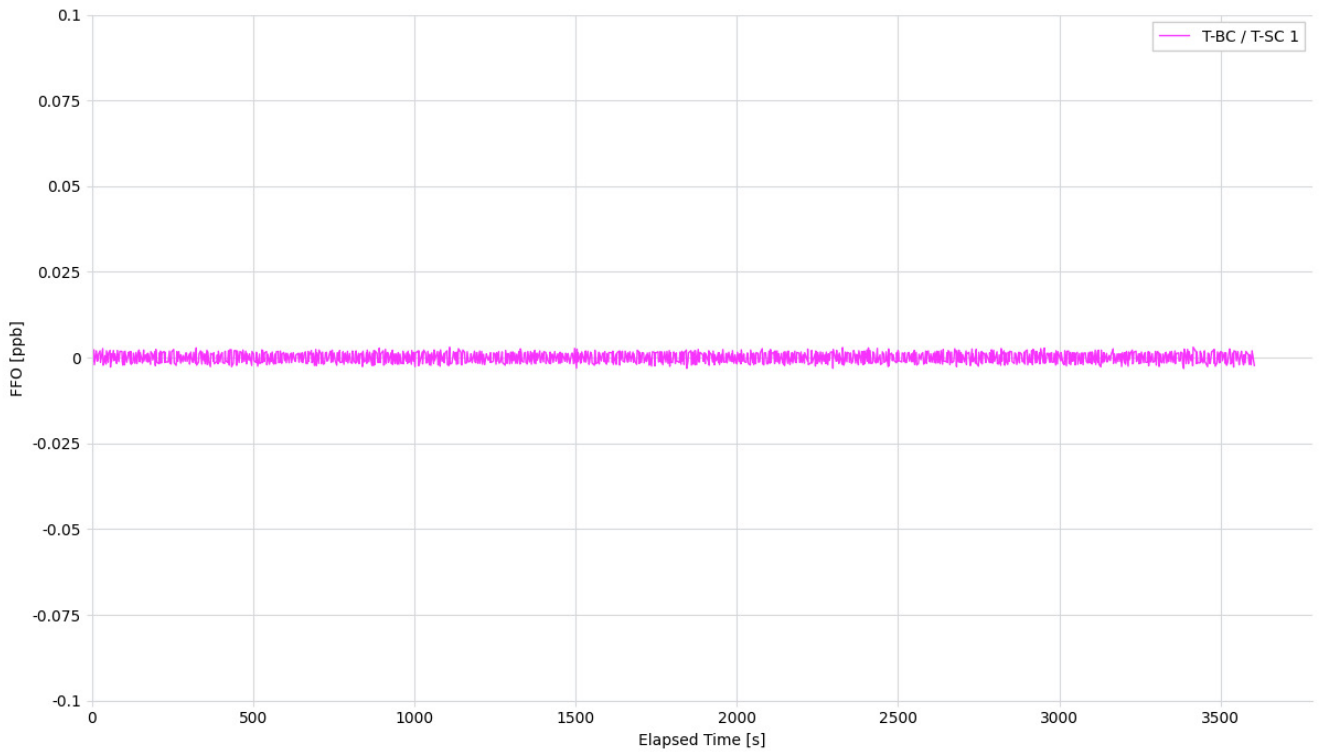

Figure 141. Holdover – G.8262 EEC Option 1, 10Hz – FFO

	T-BC / T-SC 1
Mean [ppb]	0.0
Min [ppb]	-0.003
Max [ppb]	0.003
Max-Min [ppb]	0.006

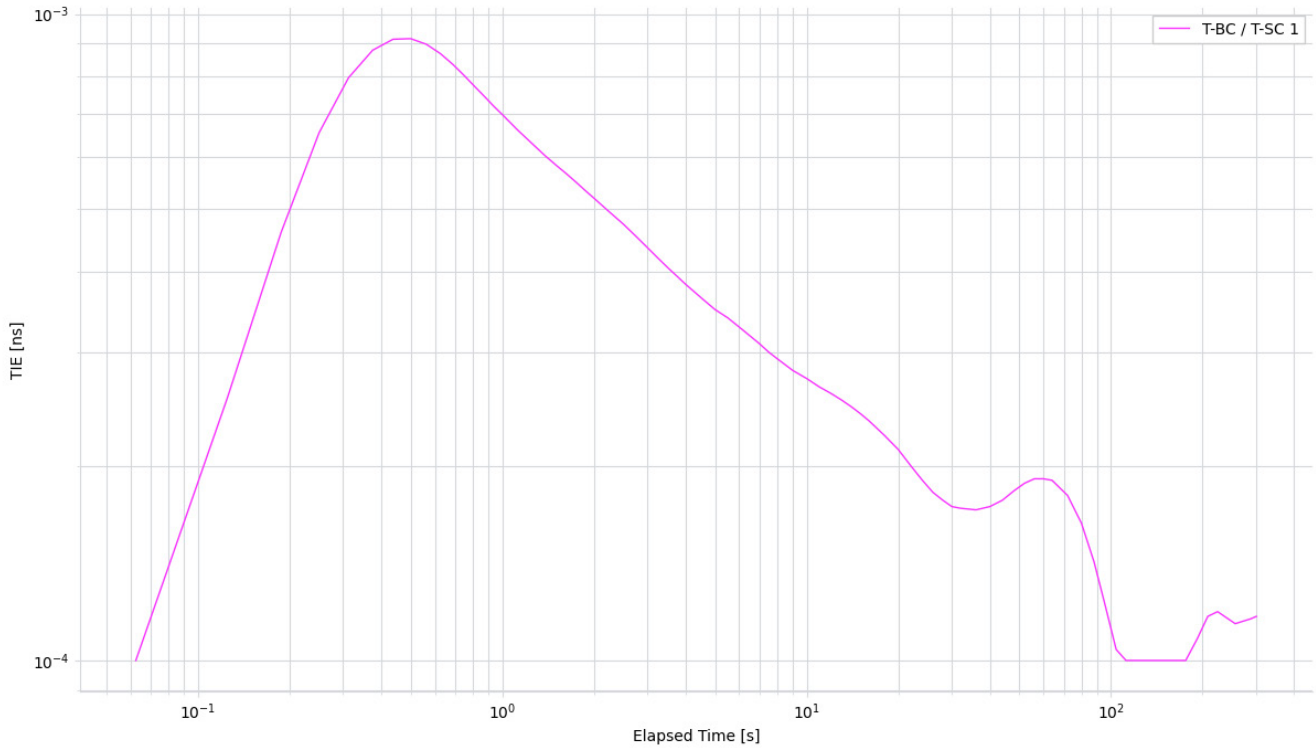

Figure 142. Holdover – G.8262 EEC Option 1, 10Hz – TDEV

	T-BC / T-SC 1
Min [ns]	0.0
Max [ns]	0.001
Max-Min [ns]	0.001

9.3 Holdover – G.8262 EEC Option 2, 0.1Hz

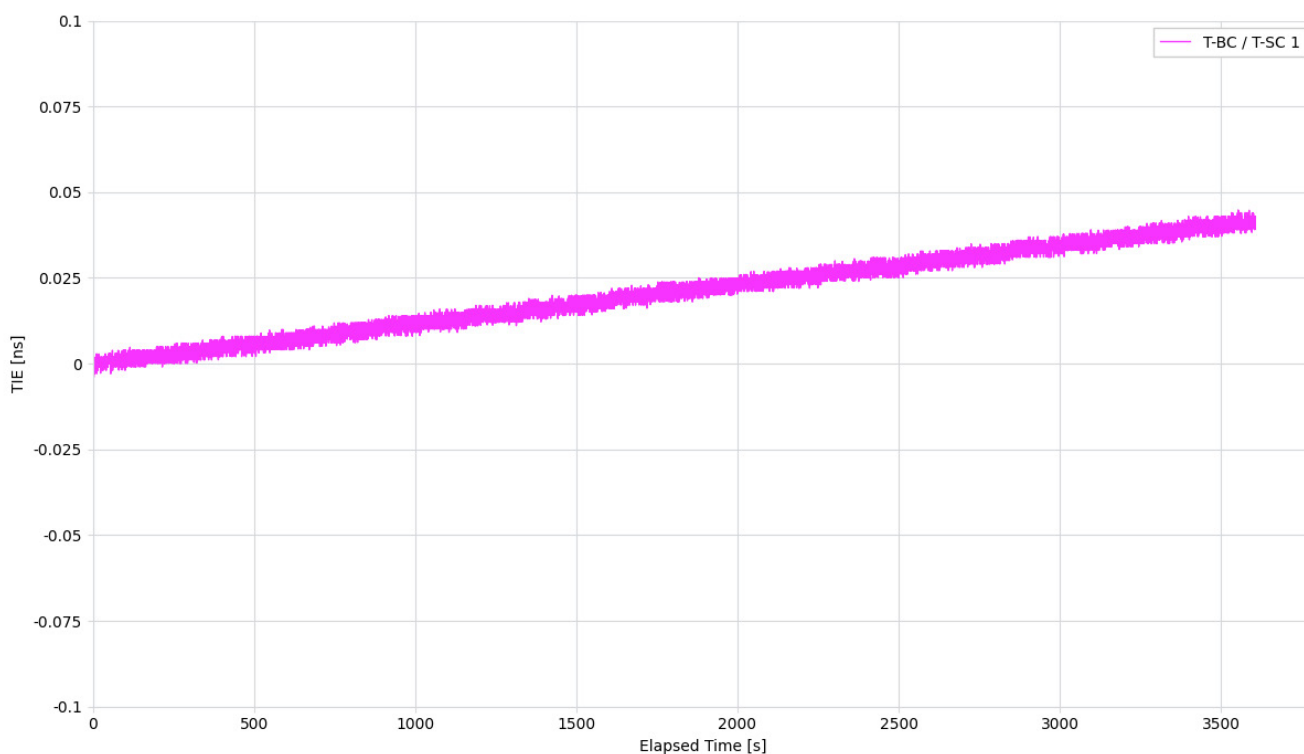

Figure 143. Holdover – G.8262 EEC Option 2, 0.1Hz – TIE (no mask)

	T-BC / T-SC 1
Mean [ns]	0.021
Min [ns]	-0.004
Max [ns]	0.045
Max-Min [ns]	0.049

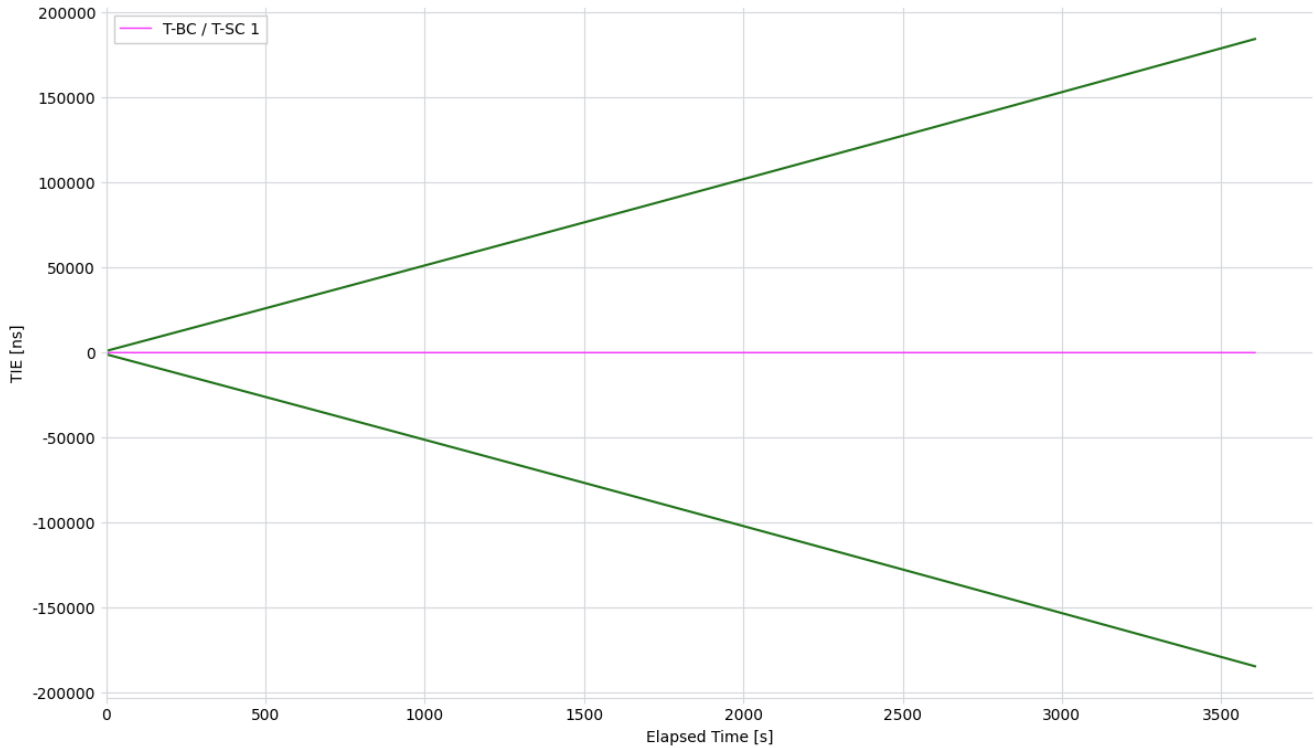

Figure 144. Holdover – G.8262 EEC Option 2, 0.1Hz – TIE

	T-BC / T-SC 1
Mean [ns]	0.021
Min [ns]	-0.004
Max [ns]	0.045
Max-Min [ns]	0.049

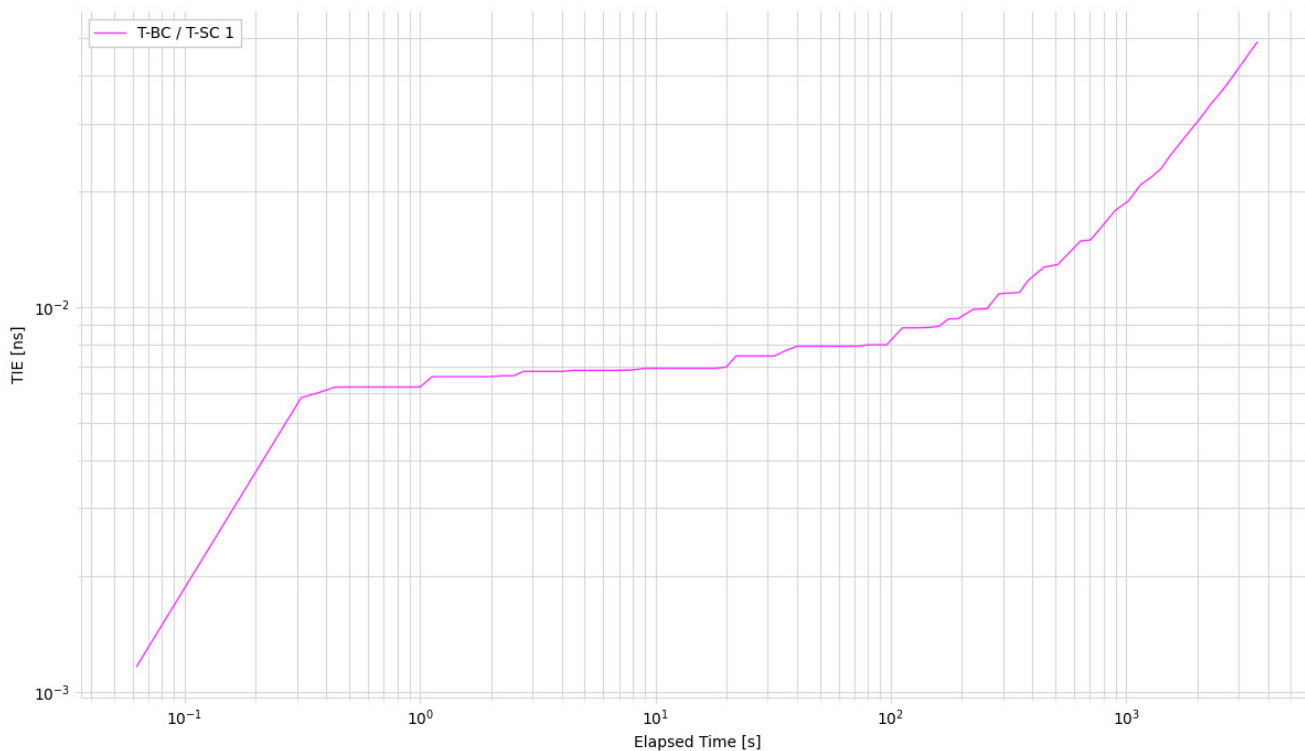

Figure 145. Holdover – G.8262 EEC Option 2, 0.1Hz – MTIE

	T-BC / T-SC 1
Min [ns]	0.001
Max [ns]	0.049
Max-Min [ns]	0.048

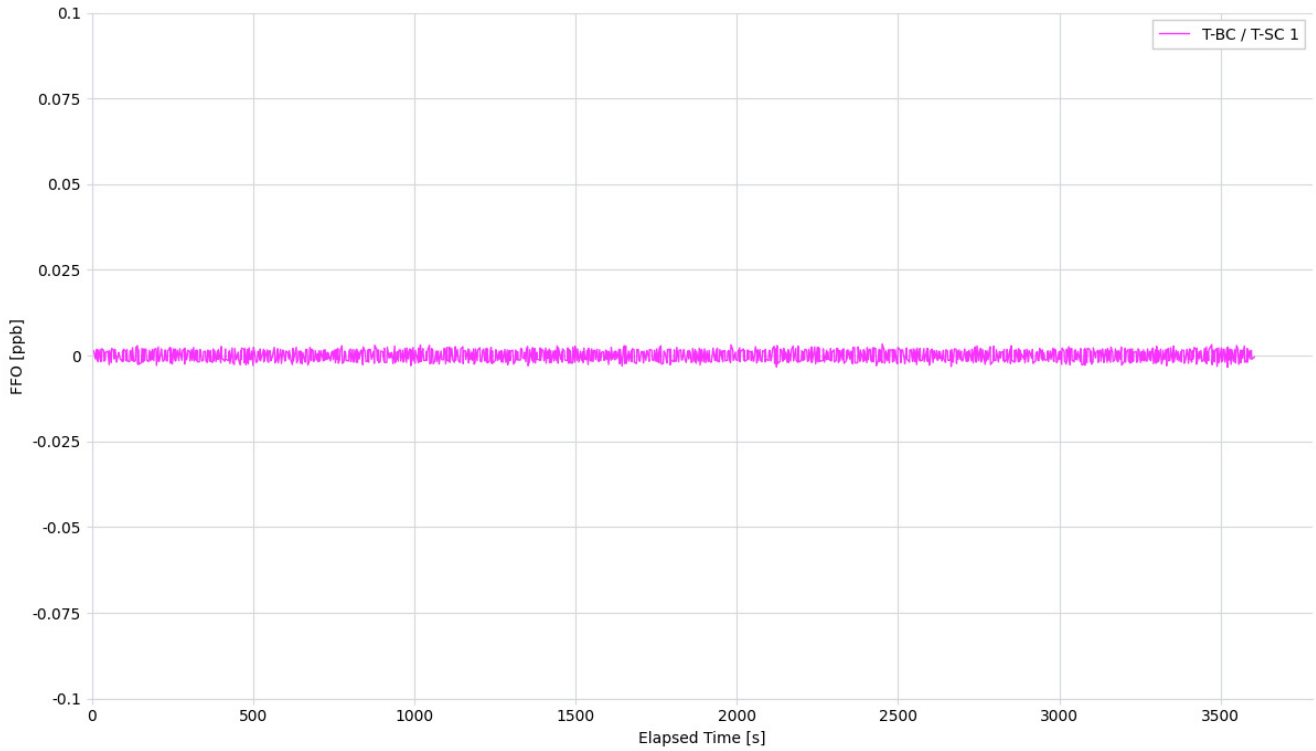

Figure 146. Holdover – G.8262 EEC Option 2, 0.1Hz – FFO

	T-BC / T-SC 1
Mean [ppb]	0.0
Min [ppb]	-0.003
Max [ppb]	0.003
Max-Min [ppb]	0.007

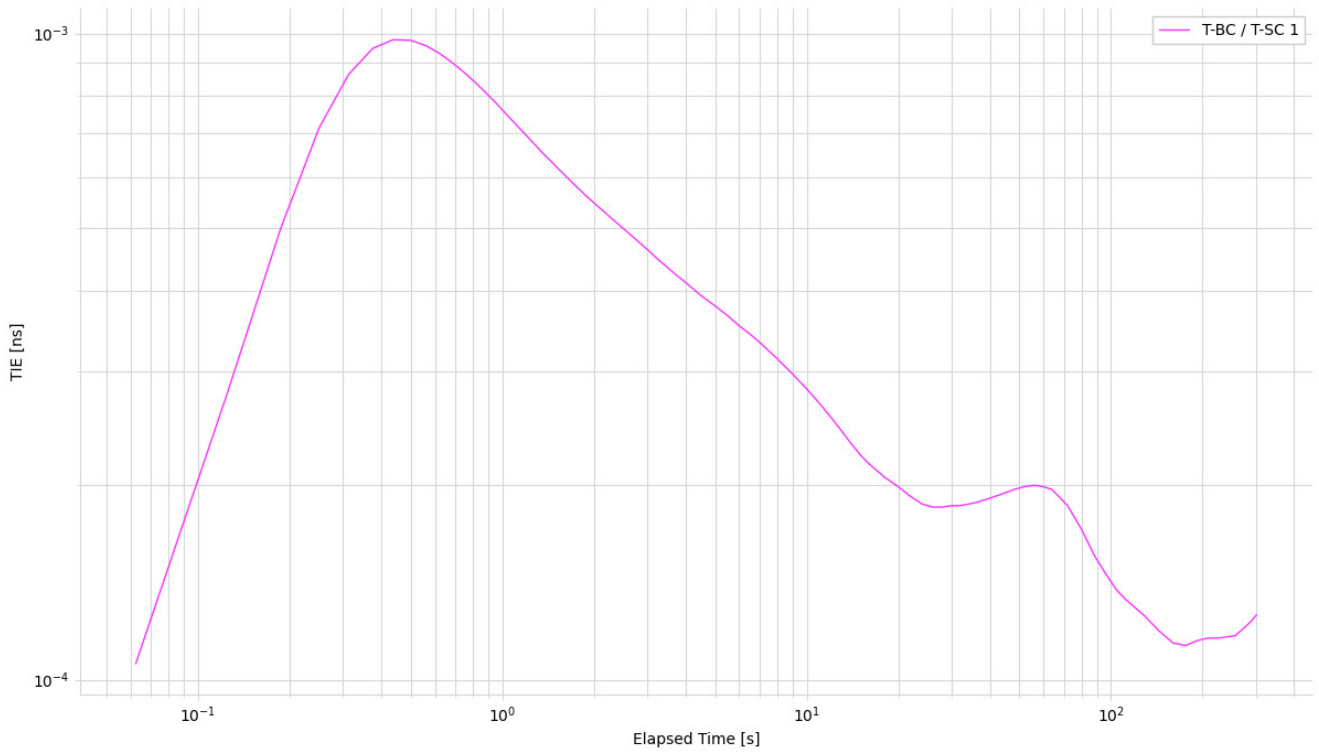

Figure 147. Holdover – G.8262 EEC Option 2, 0.1Hz – TDEV

	T-BC / T-SC 1
Min [ns]	0.0
Max [ns]	0.001
Max-Min [ns]	0.001

9.4 Holdover – G.8262.1 eEEC, 3Hz

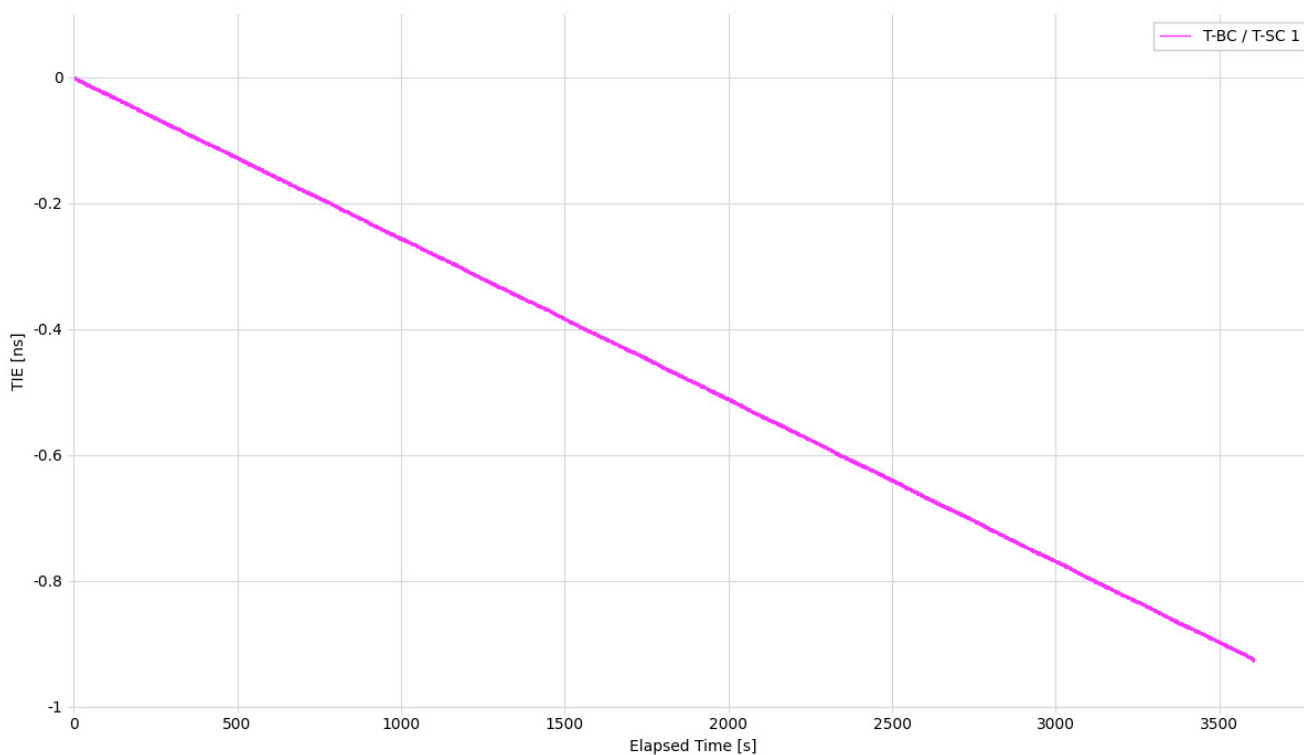

Figure 148. Holdover – G.8262.1 eEEC, 3Hz – TIE (no mask)

	T-BC / T-SC 1
Mean [ns]	-0.462
Min [ns]	-0.929
Max [ns]	0.0
Max-Min [ns]	0.929

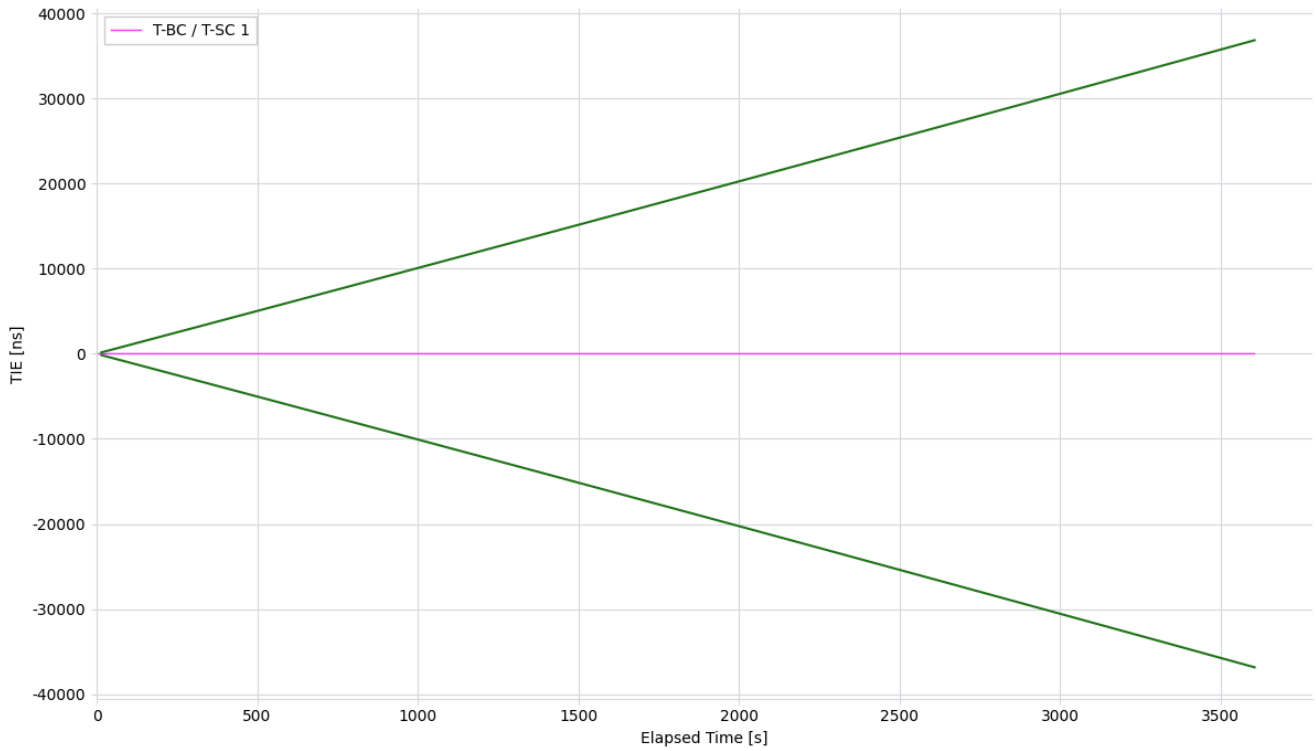

Figure 149. Holdover – G.8262.1 eEEC, 3Hz – TIE

	T-BC / T-SC 1
Mean [ns]	-0.462
Min [ns]	-0.929
Max [ns]	0.0
Max-Min [ns]	0.929

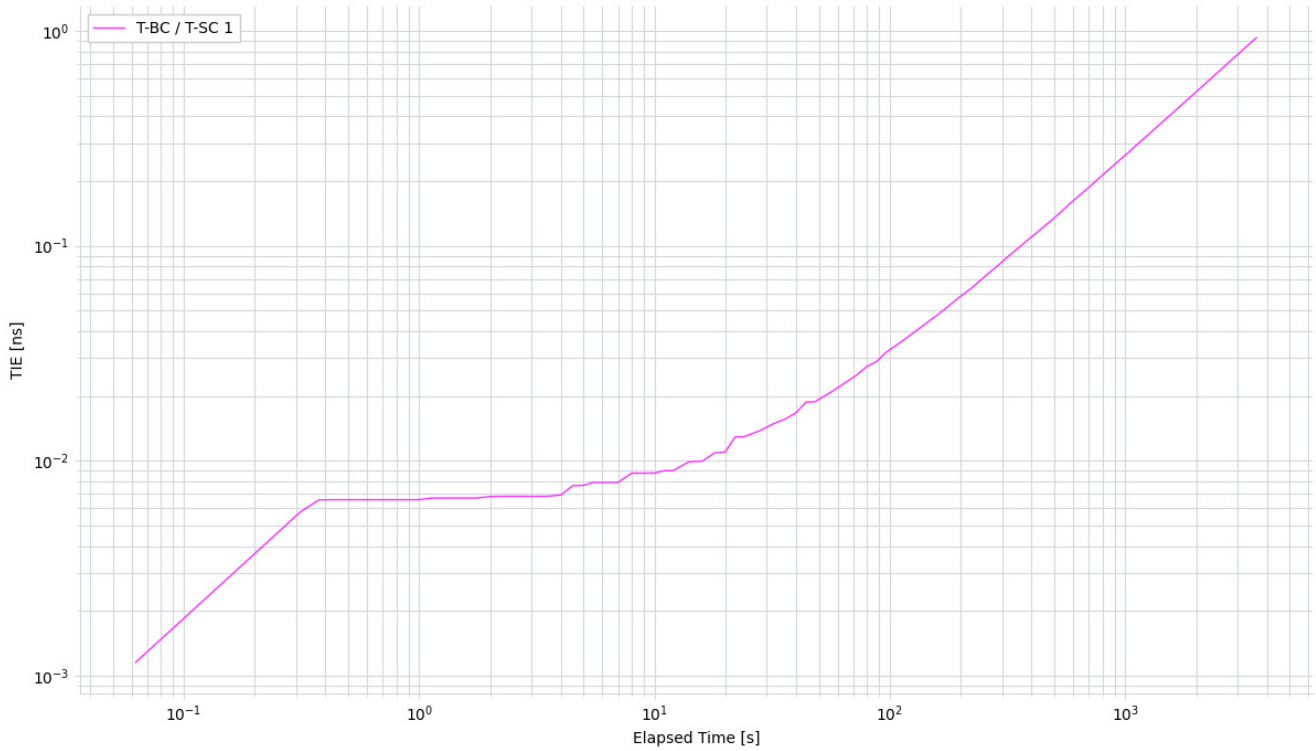

Figure 150. Holdover – G.8262.1 eEEC, 3Hz – MTIE

	T-BC / T-SC 1
Min [ns]	0.001
Max [ns]	0.929
Max-Min [ns]	0.928

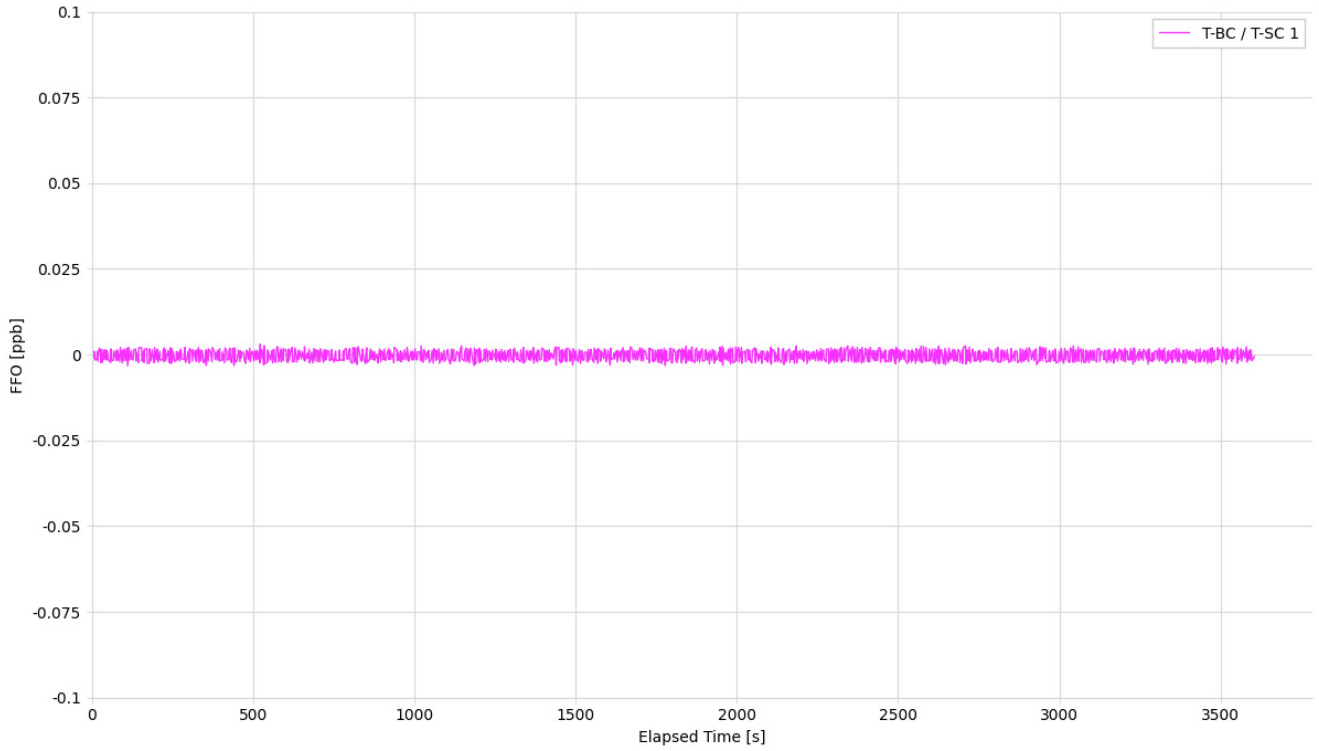

Figure 151. Holdover – G.8262.1 eEEC, 3Hz – FFO

	T-BC / T-SC 1
Mean [ppb]	-0.0
Min [ppb]	-0.003
Max [ppb]	0.003
Max-Min [ppb]	0.006

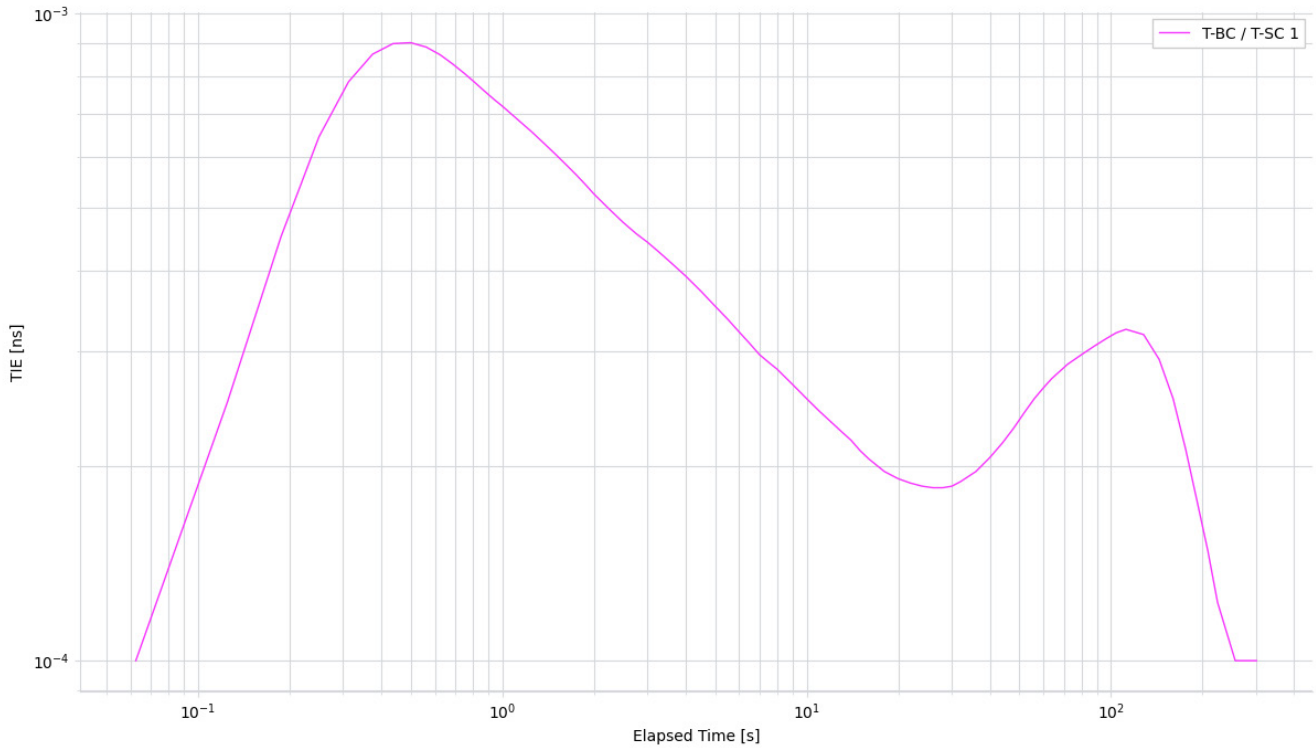

Figure 152. Holdover – G.8262.1 eEEC, 3Hz – TDEV

	T-BC / T-SC 1
Min [ns]	0.0
Max [ns]	0.001
Max-Min [ns]	0.001

10. Wander Transfer

The wander transfer requirement checks the ability of the PLL to filter wander on an input clock (see [Figure 1](#) for the equipment configuration).

The PLL can be viewed as a low pass filter for the difference between the actual input phase and the idea input phase of the reference. The bandwidths for this filter are defined in the applicable standard. For ITU-T G.8262 EEC Option 1 clocks and ITU-T G.8262.1 eEEEC clocks, the wander transfer characteristics are evaluated by applying sinusoidal wander to the input clock at various amplitudes and frequencies from a table defined in the standard. This requirement simultaneously checks the wander tolerance requirement. The wander tolerance requirement is passed if during the wander transfer test:

- There are no alarms
- The clock does not switch reference
- The clock does not go into holdover

10.1 Wander Transfer – G.8262 EEC Option 1, 1.2Hz

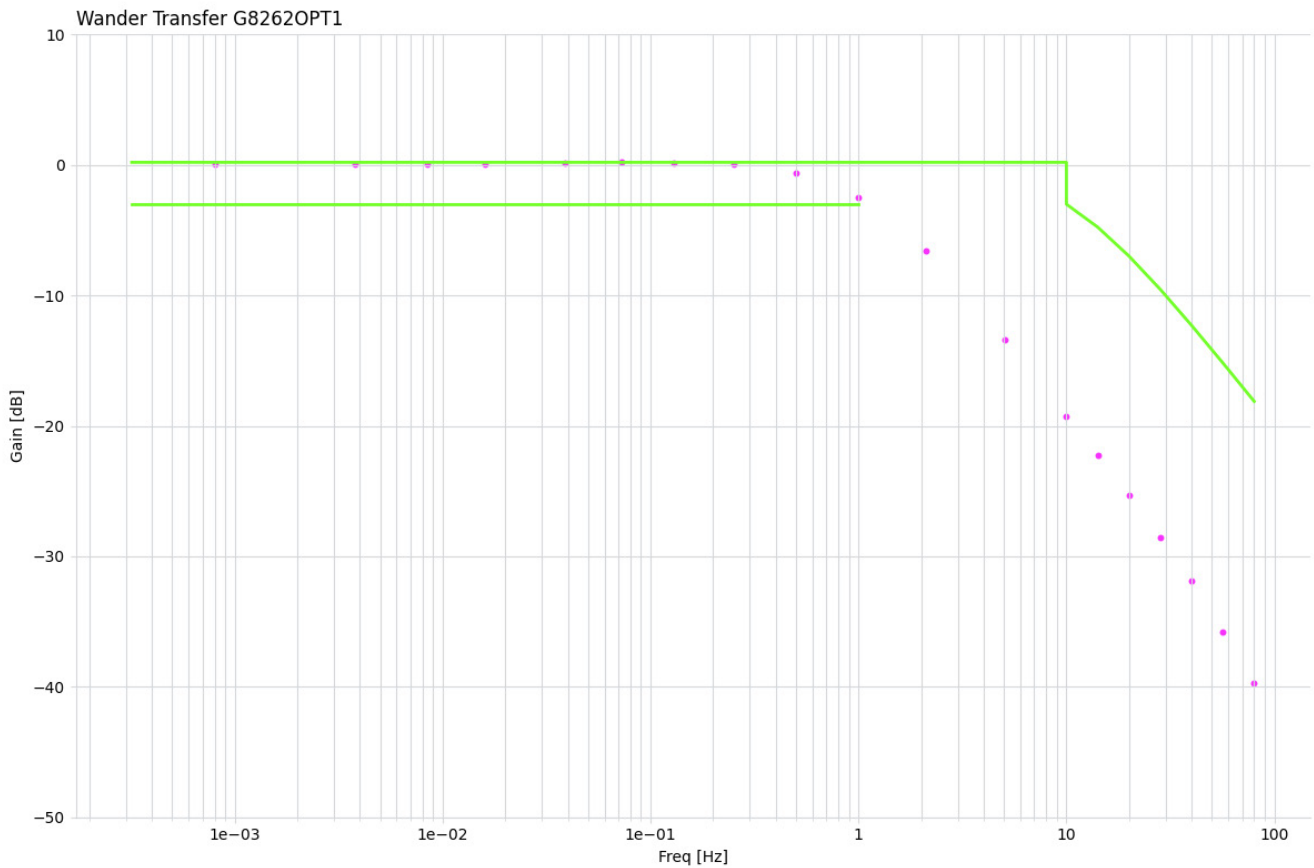

Figure 153. Wander Transfer – G.8262 EEC Option 1, 1.2Hz – Phase_Gain

10.1.1. Wander Transfer Gain Peaking for Standard G.8262 EEC Option 1, 1.2Hz

Point #	Frequency (Hz)	Amplitude (ns)	Pk-Pk Output (ns)	Gain (dB)	Upper Gain Limit (dB)	Lower Gain Limit (dB)
1	80.000	250	2.579	-39.73	-18.1	-
2	56.569	250	4.044	-35.823	-15.1	-
3	40.000	250	8.343	-31.875	-12.0	-
4	28.284	250	9.305	-28.584	-9.0	-
5	20.000	250	13.502	-25.351	-6.0	-
6	14.140	250	19.265	-22.263	-3.0	-
7	10.000	250	27.305	-19.234	0.2	-
8	5.0650	250	53.295	-13.425	0.2	-
9	2.1040	250	116.804	-6.61	0.2	-
10	1.0000	250	188.202	-2.466	0.2	-3.0
11	0.5000	250	232.85	-0.617	0.2	-3.0
12	0.2500	250	250.699	0.024	0.2	-3.0
13	0.1300	250	255.528	0.19	0.2	-3.0
14	0.0730	438	448.101	0.198	0.2	-3.0
15	0.0388	825	841.386	0.171	0.2	-3.0
16	0.0160	2000	2017.621	0.076	0.2	-3.0
17	0.0084	2000	2008.734	0.038	0.2	-3.0
18	0.0038	2000	2008.633	0.037	0.2	-3.0
19	0.0008	2000	2009.141	0.04	0.2	-3.0

10.2 Wander Transfer – G.8262 EEC Option 1, 10Hz

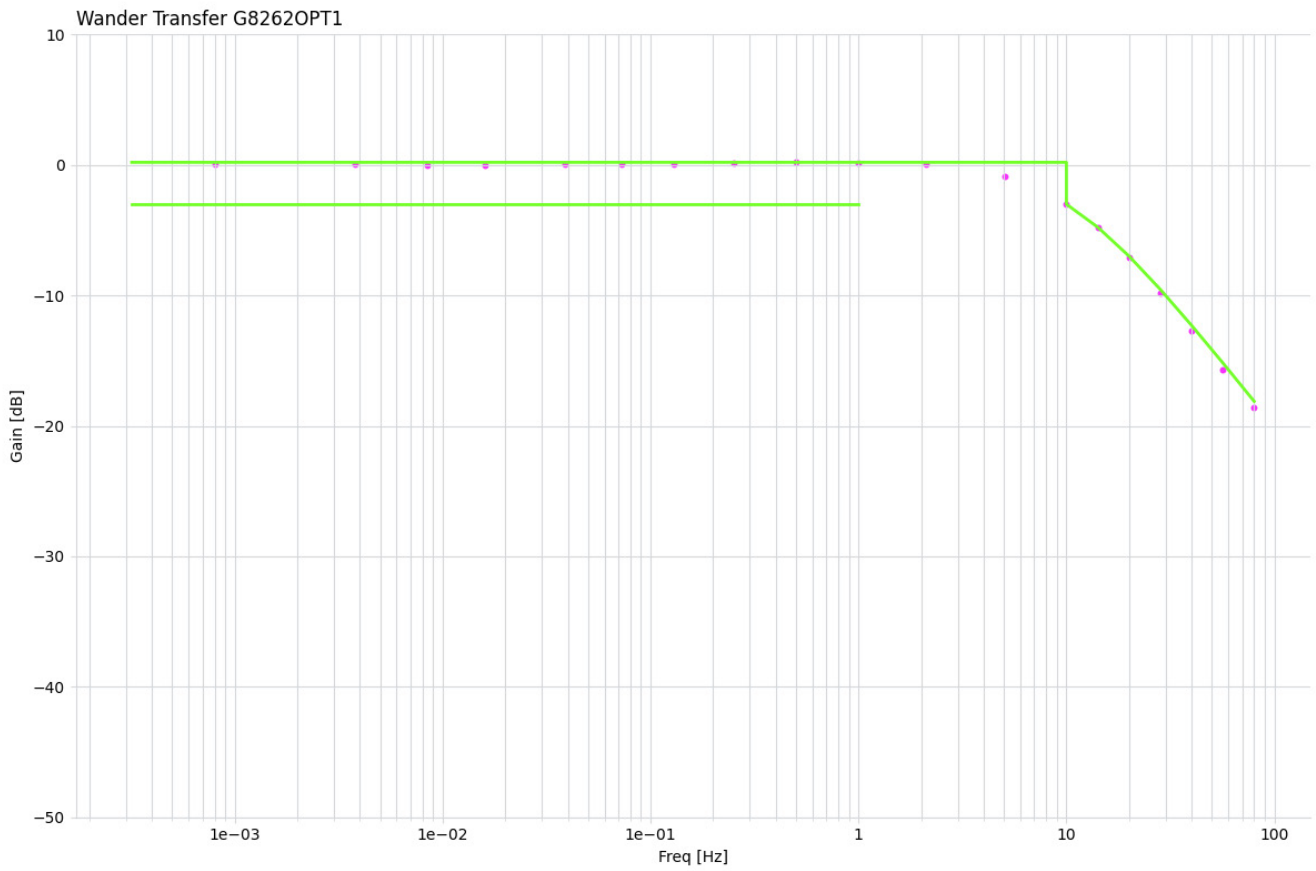

Figure 154. Wander Transfer – G.8262 EEC Option 1, 10Hz – Phase_Gain

10.2.1. Wander Transfer Gain Peaking for Standard G.8262 EEC Option 1, 10Hz

Point #	Frequency (Hz)	Amplitude (ns)	Pk-Pk Output (ns)	Gain (dB)	Upper Gain Limit (dB)	Lower Gain Limit (dB)
1	80.000	250	29.328	-18.613	-18.1	-
2	56.569	250	41.058	-15.691	-15.1	-
3	40.000	250	57.947	-12.698	-12.0	-
4	28.284	250	80.904	-9.799	-9.0	-
5	20.000	250	110.434	-7.097	-6.0	-
6	14.140	250	143.705	-4.809	-3.0	-
7	10.000	250	177.583	-2.971	0.2	-
8	5.0650	250	227.136	-0.833	0.2	-
9	2.1040	250	250.8	0.028	0.2	-
10	1.0000	250	254.946	0.17	0.2	-3.0
11	0.5000	250	255.554	0.191	0.2	-3.0
12	0.2500	250	253.481	0.12	0.2	-3.0
13	0.1300	250	251.263	0.044	0.2	-3.0
14	0.0730	438	439.659	0.033	0.2	-3.0
15	0.0388	825	826.965	0.021	0.2	-3.0
16	0.0160	2000	2004.52	0.02	0.2	-3.0
17	0.0084	2000	2003.808	0.017	0.2	-3.0
18	0.0038	2000	2005.383	0.023	0.2	-3.0
19	0.0008	2000	2007.21	0.031	0.2	-3.0

10.3 Wander Transfer – G.8262 EEC Option 2, 0.1Hz

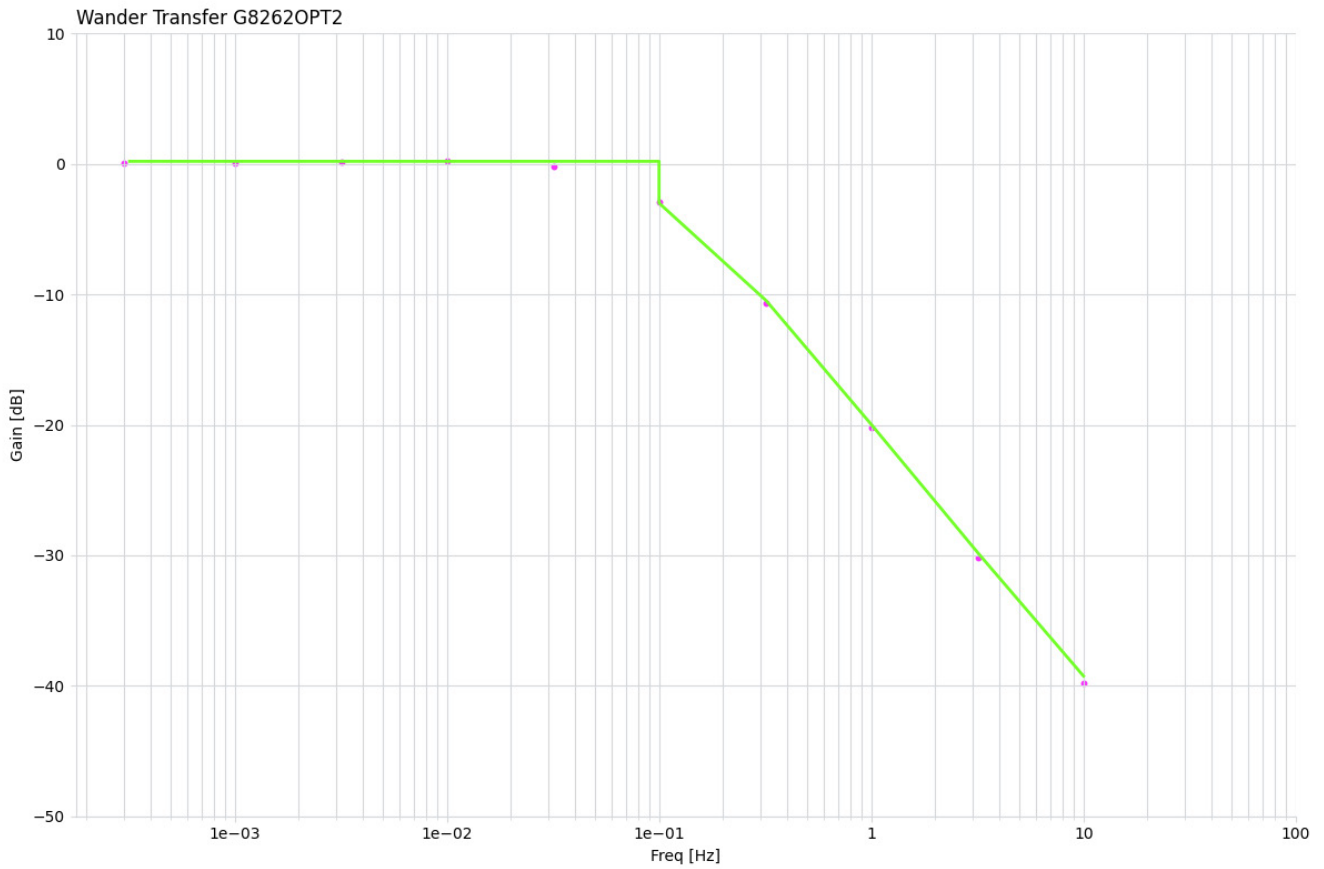

Figure 155. Wander Transfer – G.8262 EEC Option 2, 0.1Hz – Phase_Gain

10.3.1. Wander Transfer Gain Peaking for Standard G.8262 EEC Option 2, 0.1Hz

Point #	Frequency (Hz)	Amplitude (ns)	Pk-Pk Output (ns)	Gain (dB)	Upper Gain Limit (dB)
1	10.000	300	3.064	-39.815	-39.8
2	3.2000	300	9.304	-30.2	-29.9
3	1.0000	301	29.48	-20.181	-19.8
4	0.3200	303	88.893	-10.652	-9.9
5	0.1000	308	219.322	-2.949	0.2
6	0.0320	325	317.329	-0.207	0.2
7	0.0100	380	388.675	0.196	0.2
8	0.0032	550	560.467	0.164	0.2
9	0.0010	1000	1007.592	0.066	0.2
10	0.0003	1007	1013.482	0.056	0.2

10.4 Wander Transfer – G.8262.1 eEEC, 3Hz

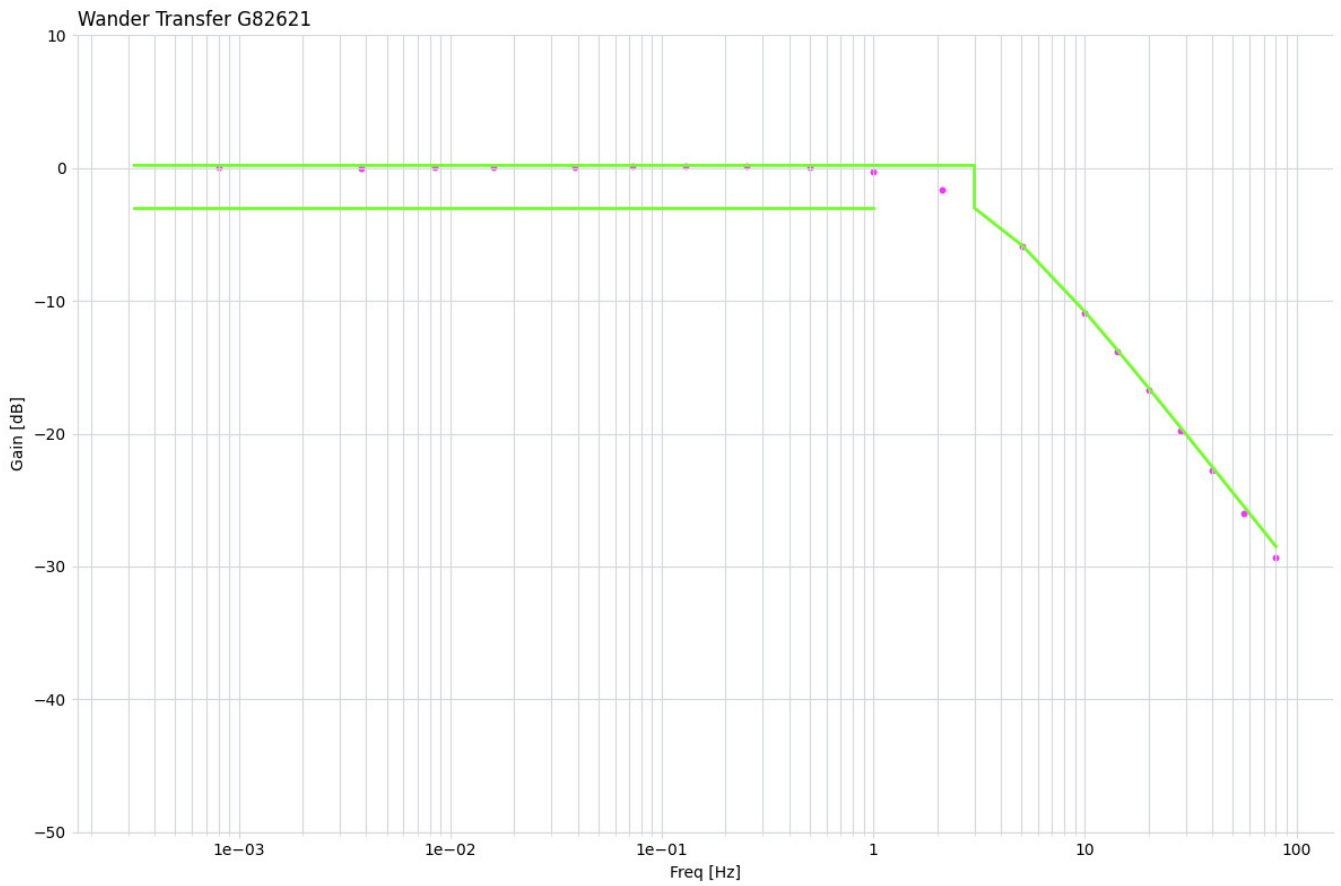

Figure 156. Wander Transfer – G.8262.1 eEEC, 3Hz – Phase_Gain

10.4.1. Wander Transfer Gain Peaking for Standard G.8262.1 eEEC, 3Hz

Point #	Frequency (Hz)	Amplitude (ns)	Pk-Pk Output (ns)	Gain (dB)	Upper Gain Limit (dB)	Lower Gain Limit (dB)
1	80.000	250	8.545	-29.325	-28.5	-
2	56.569	250	12.49	-26.028	-25.5	-
3	40.000	250	18.103	-22.804	-22.5	-
4	28.284	250	25.737	-19.748	-19.5	-
5	20.000	250	36.458	-16.723	-16.5	-
6	14.140	250	51.071	-13.795	-13.5	-
7	10.000	250	71.196	-10.91	-10.5	-
8	5.0650	250	126.967	-5.885	-4.5	-
9	2.1040	250	207.366	-1.624	0.2	-3.0
10	1.0000	250	242.407	-0.268	0.2	-3.0
11	0.5000	250	252.773	0.096	0.2	-3.0
12	0.2500	250	255.301	0.182	0.2	-3.0
13	0.1300	250	254.869	0.168	0.2	-3.0
14	0.0730	438	443.723	0.113	0.2	-3.0
15	0.0388	825	831.179	0.065	0.2	-3.0
16	0.0160	2000	2006.652	0.029	0.2	-3.0
17	0.0084	2000	2005.484	0.024	0.2	-3.0
18	0.0038	2000	2003.96	0.017	0.2	-3.0
19	0.0008	2000	2007.11	0.031	0.2	-3.0

11. Phase Noise and RMS Jitter

The data in this section displays phase noise plots and RMS jitter a RC38312A200 device when using the G.8262 option 1, G.8262 option 2, and G.8262.1 eEEC register settings in Table 2 and Table 3. The System DLL reference clock, CLKIN3, is supplied by a Rakon E6241LF, 12.8MHz TCXO. The RF_Out output of a Rohde & Schwarz SMA100B is used to supply the 25MHz reference clock, CLKIN1, for the jitter attenuator DLL, DPLL0. The XIN input is supplied by a NDK RNA5024A, 54MHz XO. A 156.25MHz HCSL, internally terminated output from the RC38312A200 EVB, is connected through a Prodyn BIB-100F balun to a Keysight FSWP signal source analyzer. Figure 157 shows a block diagram of the measurement setup.

The FSWP phase noise plots shown in this section each simultaneously plot two phase noise traces. The two traces are of the same signal with different FSWP trace smoothing and spur suppression settings. Trace 1 has smoothing disabled, thus any spurs on the carrier are visible and accounted for in the RMS jitter value. Trace 2 has smoothing enabled, thus any spurs on the carrier are reduced to better showcase the noise floor. The RMS jitter for Trace 2 is more reflective of an ideal carrier with no spurs.

Table 7. Summary of RMS Jitter Measurements

XTAL Frequency	TCXO Frequency	Profile	Bandwidth	RMS Jitter
49.152MHz	12.8MHz	ITU-T G.8262 EEC Option 1	1.2Hz	59.170fs
		ITU-T G.8262 EEC Option 1	10Hz	59.852fs
		ITU-T G.8262 EEC Option 2	0.1Hz	58.949fs
		ITU-T G.8262.1 eEEC	3Hz	58.775fs

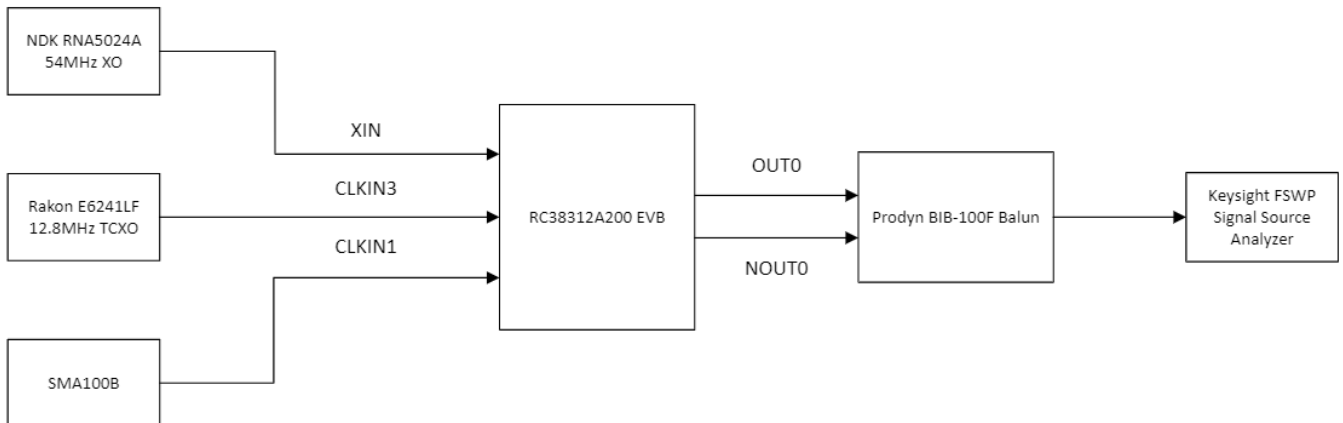

Figure 157. Phase Noise and RMS Jitter Measurement Setup

11.1 Phase Noise and RMS Jitter: ITU-T G.8262 EEC Option 1, 1.2Hz Bandwidth, 54MHz XO, 12.8MHz TXCO

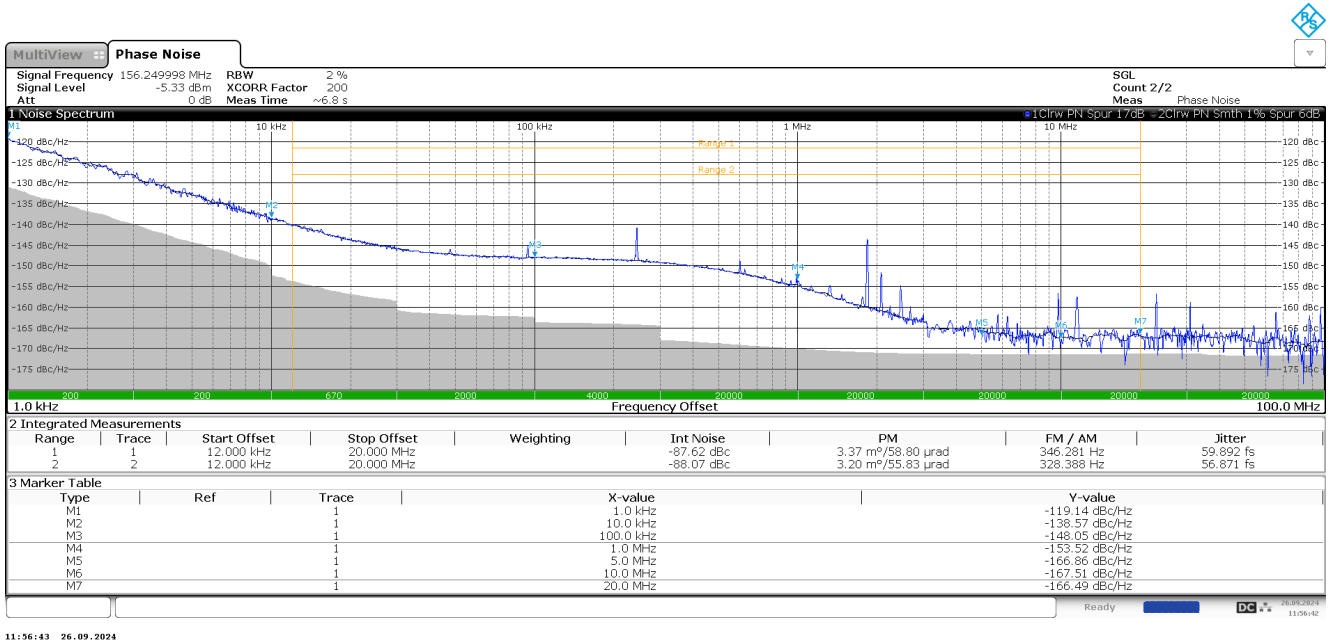

Figure 158. Phase Noise and RMS Jitter for ITU-T G.8262 EEC Option 1, 1.2Hz Bandwidth, 156.25MHz Output, Using a 54MHz XO and a 12.8MHz TCXO

11.2 Phase Noise and RMS Jitter: ITU-T G.8262 EEC Option 1, 10Hz Bandwidth, 54MHz XO, 12.8MHz TXCO

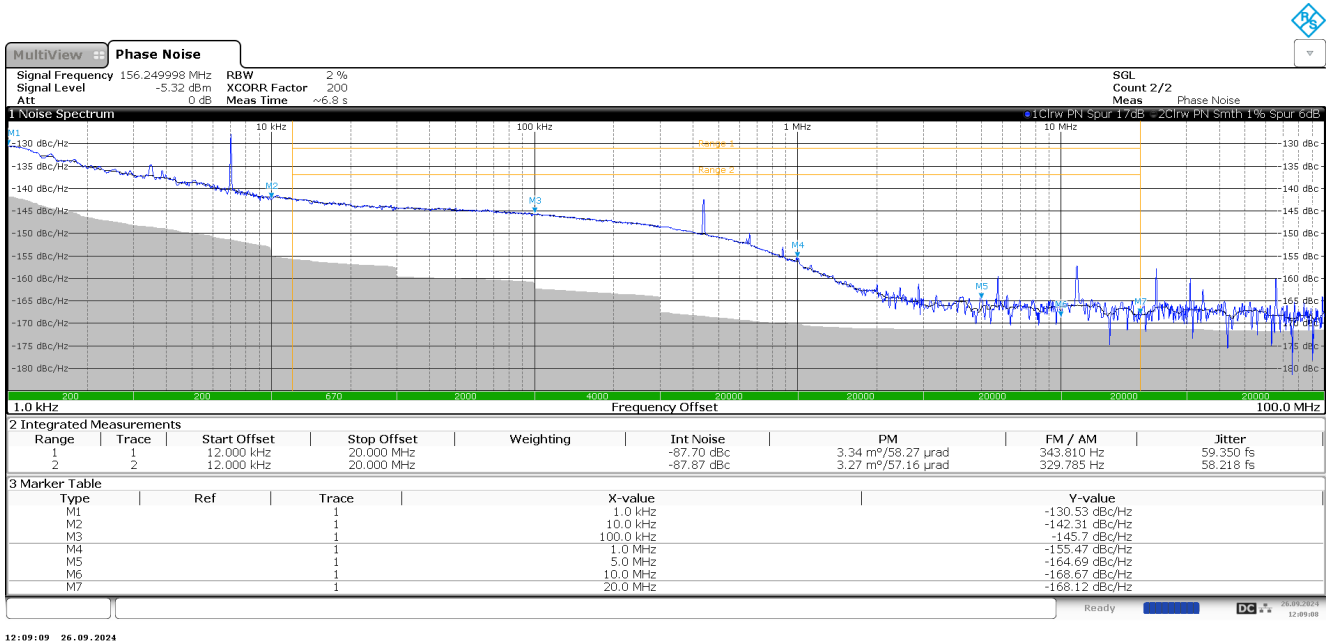

Figure 159. Phase Noise and RMS Jitter for ITU-T G.8262 EEC Option 1, 10Hz Bandwidth, 156.25MHz Output, Using a 54MHz XO and a 12.8MHz TCXO

11.3 Phase Noise and RMS Jitter: ITU-T G.8262 EEC Option 2, 0.1Hz Bandwidth, 54MHz XO, 12.8MHz TXCO

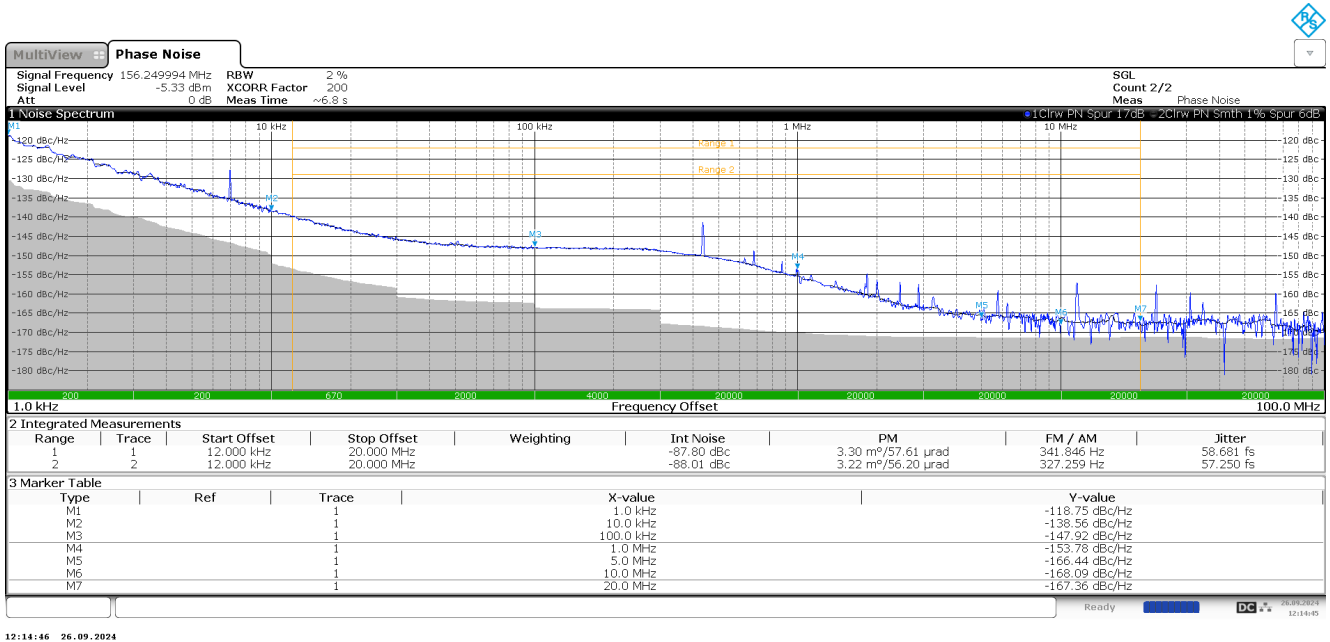

Figure 160. Phase Noise and RMS Jitter for ITU-T G.8262 EEC Option 2, 0.1Hz Bandwidth, 156.25MHz Output, Using a 54MHz XO and a 12.8MHz TCXO

11.4 Phase Noise and RMS Jitter: ITU-T G.8262.1 eEEC, 3Hz Bandwidth, 54MHz XO, 12.8MHz TXCO

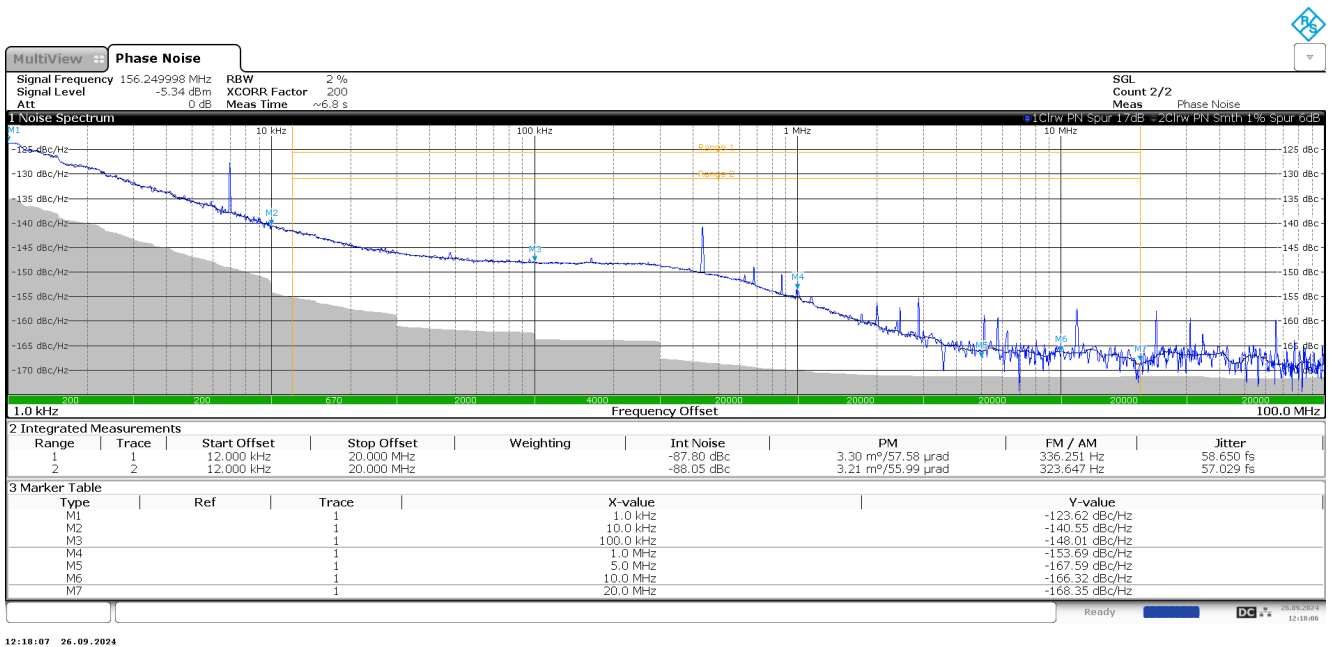

Figure 161. Phase Noise and RMS Jitter for ITU-T G.8262 eEEC, 3Hz Bandwidth, 156.25MHz Output, Using a 54MHz XO and a 12.8MHz TCXO

12. Revision History

Revision	Date	Description
1.00	Oct 4, 2024	Initial release.

IMPORTANT NOTICE AND DISCLAIMER

RENESAS ELECTRONICS CORPORATION AND ITS SUBSIDIARIES (“RENESAS”) PROVIDES TECHNICAL SPECIFICATIONS AND RELIABILITY DATA (INCLUDING DATASHEETS), DESIGN RESOURCES (INCLUDING REFERENCE DESIGNS), APPLICATION OR OTHER DESIGN ADVICE, WEB TOOLS, SAFETY INFORMATION, AND OTHER RESOURCES “AS IS” AND WITH ALL FAULTS, AND DISCLAIMS ALL WARRANTIES, EXPRESS OR IMPLIED, INCLUDING, WITHOUT LIMITATION, ANY IMPLIED WARRANTIES OF MERCHANTABILITY, FITNESS FOR A PARTICULAR PURPOSE, OR NON-INFRINGEMENT OF THIRD-PARTY INTELLECTUAL PROPERTY RIGHTS.

These resources are intended for developers who are designing with Renesas products. You are solely responsible for (1) selecting the appropriate products for your application, (2) designing, validating, and testing your application, and (3) ensuring your application meets applicable standards, and any other safety, security, or other requirements. These resources are subject to change without notice. Renesas grants you permission to use these resources only to develop an application that uses Renesas products. Other reproduction or use of these resources is strictly prohibited. No license is granted to any other Renesas intellectual property or to any third-party intellectual property. Renesas disclaims responsibility for, and you will fully indemnify Renesas and its representatives against, any claims, damages, costs, losses, or liabilities arising from your use of these resources. Renesas' products are provided only subject to Renesas' Terms and Conditions of Sale or other applicable terms agreed to in writing. No use of any Renesas resources expands or otherwise alters any applicable warranties or warranty disclaimers for these products.

(Disclaimer Rev.1.01 Jan 2024)

Corporate Headquarters

TOYOSU FORESIA, 3-2-24 Toyosu,
Koto-ku, Tokyo 135-0061, Japan
www.renesas.com

Trademarks

Renesas and the Renesas logo are trademarks of Renesas Electronics Corporation. All trademarks and registered trademarks are the property of their respective owners.

Contact Information

For further information on a product, technology, the most up-to-date version of a document, or your nearest sales office, please visit www.renesas.com/contact-us/.