

RRT75474-DNT

4 x 128Gbaud Linear Differential I/O Driver

Description

The RRT75474-DNT is a low-power, high-performance, 128Gbaud quad-channel linear driver chip. The device is designed for 800Gbps and beyond optical integrated transmitter small-form factor (SFF) modules for metro and long-haul applications.

The RRT75474-DNT integrates analog control and digital (through an SPI interface) control circuitry for precise, independent driving level control and monitoring. Each driver channel has 100Ω differential AC-coupled input and 60Ω differential interface with an open-collector type output stage and is suitable for InP based, Thin-Film Lithium Niobate, and Silicon Photonics based Mach-Zehnder modulators.

Applications

- 800G and beyond advanced multi-level QAM modulation systems
- High-bandwidth small form factor optical integrated module

Features

- > 85GHz 3dB bandwidth with > 70GHz peaking frequency
- 14dB (typical) of peaking to compensate for package and modulator losses
- > 10dB dynamic range of gain control
- 3.2W (typical) power consumption for 4.0Vppd output voltage swing
- AC-coupled 100Ω differential input
- Open-collector configuration output stage that can drive DC-coupled 60Ω differential
- Ultra-low inter-channel crosstalk
- Precise analog and digital monitoring and control of gain and output voltage swing
- < 1MHz low-frequency cutoff
- Optical Internetworking Forum (OIF)-compliant Serial Peripheral Interface (SPI) for programmability

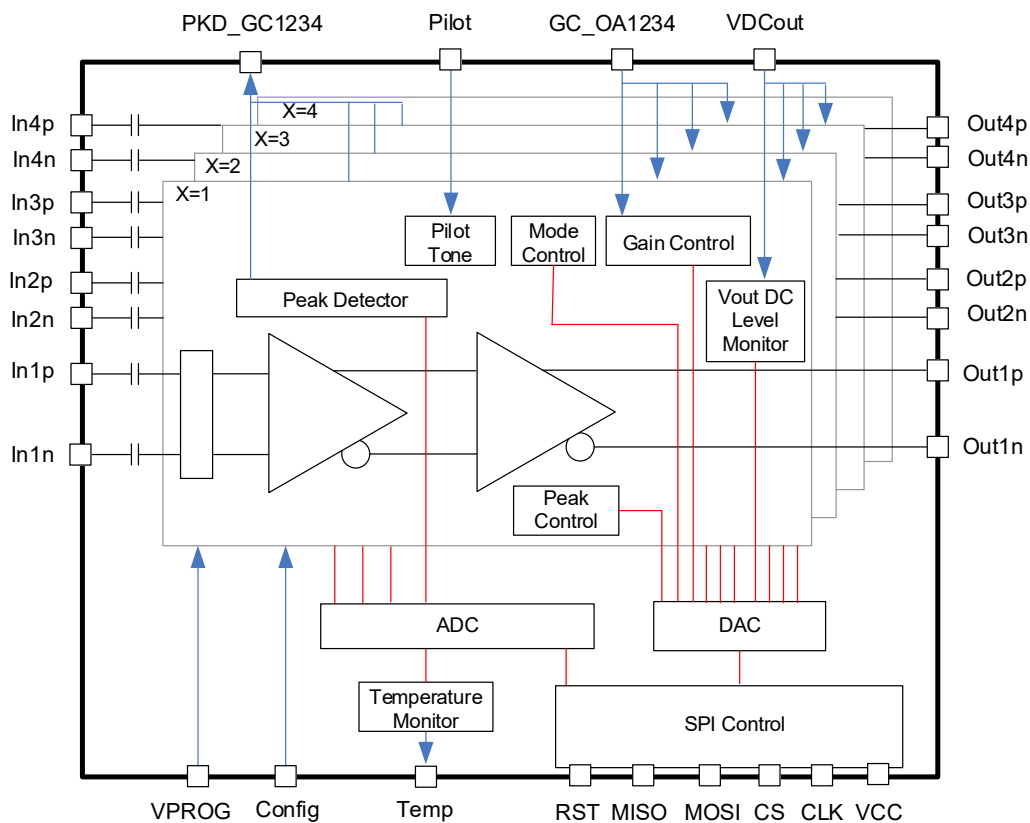

Figure 1. Block Diagram

## IMPORTANT NOTICE AND DISCLAIMER

RENESAS ELECTRONICS CORPORATION AND ITS SUBSIDIARIES (“RENESAS”) PROVIDES TECHNICAL SPECIFICATIONS AND RELIABILITY DATA (INCLUDING DATASHEETS), DESIGN RESOURCES (INCLUDING REFERENCE DESIGNS), APPLICATION OR OTHER DESIGN ADVICE, WEB TOOLS, SAFETY INFORMATION, AND OTHER RESOURCES “AS IS” AND WITH ALL FAULTS, AND DISCLAIMS ALL WARRANTIES, EXPRESS OR IMPLIED, INCLUDING, WITHOUT LIMITATION, ANY IMPLIED WARRANTIES OF MERCHANTABILITY, FITNESS FOR A PARTICULAR PURPOSE, OR NON-INFRINGEMENT OF THIRD-PARTY INTELLECTUAL PROPERTY RIGHTS.

These resources are intended for developers who are designing with Renesas products. You are solely responsible for (1) selecting the appropriate products for your application, (2) designing, validating, and testing your application, and (3) ensuring your application meets applicable standards, and any other safety, security, or other requirements. These resources are subject to change without notice. Renesas grants you permission to use these resources only to develop an application that uses Renesas products. Other reproduction or use of these resources is strictly prohibited. No license is granted to any other Renesas intellectual property or to any third-party intellectual property. Renesas disclaims responsibility for, and you will fully indemnify Renesas and its representatives against, any claims, damages, costs, losses, or liabilities arising from your use of these resources. Renesas' products are provided only subject to Renesas' Terms and Conditions of Sale or other applicable terms agreed to in writing. No use of any Renesas resources expands or otherwise alters any applicable warranties or warranty disclaimers for these products.

(Disclaimer Rev.1.01)

### Corporate Headquarters

TOYOSU FORESIA, 3-2-24 Toyosu,  
Koto-ku, Tokyo 135-0061, Japan  
[www.renesas.com](http://www.renesas.com)

### Trademarks

Renesas and the Renesas logo are trademarks of Renesas Electronics Corporation. All trademarks and registered trademarks are the property of their respective owners.

### Contact Information

For further information on a product, technology, the most up-to-date version of a document, or your nearest sales office, please visit [www.renesas.com/contact-us/](http://www.renesas.com/contact-us/).