

ISL70061SEH

PSpice Simulation Results

Abstract

The ISL70061SEH PSpice model is a nominal model of the ISL70061SEH load switch IC. It simulates the load switch functionality and the typical performance across temperature of the datasheet specification parameters. Basic ON/OFF control, Undervoltage Lockout (UVLO), Reverse Current Protection (RCP), selectable discharge MOSFET feature, and slow turn-on controlled rise time functions are modeled. The model simulations closely match the typical performance curves in the datasheet.

The first section of this document provides a brief explanation of using the model to generate a general functional test simulation. The simulation shows the functionality of ON/OFF control, UVLO, slow turn-on rise time, and the selectable discharge MOSFET feature.

The second section shows PSpice simulation results of the load switch compared to characterization test results using the ISL70061SEHEV1Z evaluation board. Parameters for r_{ON} vs V_{SWI} vs temperature, r_{ON} vs I_{SW} vs temperature, turn-on and turn-off waveforms, and I_{RCP} enter vs V_{SWO} vs temperature response are compared in this report.

Contents

1.	PSpice General Functional Test Simulation	3
1.1	ISL70061SEH.LIB and ISL70061SEH.OLB PSpice Files	3
1.2	Functional Simulation Schematic	3
1.3	Functional Simulation Results	4
2.	PSpice Simulation Results Verses Characterization Test Results	5
2.1	r_{ON} vs V_{SWI} vs Temperature	5
2.2	r_{ON} vs I_{SWO} vs Temperature	6
2.3	Turn-ON and Turn-OFF Waveforms	7
2.4	Reverse Current Protection (RCP) Waveforms	10
2.5	Conclusion	10
3.	Revision History	10

List of Figures

Figure 1.	ISL70061SEH Sub-Circuit (ISL70061SEH.OLB)	3
Figure 2.	ISL70061SEH.LIB	3
Figure 3.	ISL70061SEH PSpice General Functional Test Schematic	3
Figure 4.	ISL70061SEH PSpice General Functional Simulation Results	4
Figure 5.	ISL70061SEHEV1Z Rev. A Evaluation Board Schematic	5
Figure 6.	r_{ON} vs V_{SWI} vs Temperature, $I_{SW} = 1A$ (PSpice Results)	6
Figure 7.	r_{ON} vs V_{SWI} vs Temperature, $I_{SW} = 1A$ (Characterization Results)	6
Figure 8.	r_{ON} vs V_{SWI} vs Temperature, $I_{SW} = 3A$ (PSpice Results)	6
Figure 9.	r_{ON} vs V_{SWI} vs Temperature, $I_{SW} = 3A$ (Characterization Results)	6
Figure 10.	r_{ON} vs I_{SW} vs Temperature, $V_{SWI} = 3V$ (PSpice Results)	7
Figure 11.	r_{ON} vs I_{SW} vs Temperature, $V_{SWI} = 3V$ (Characterization Results)	7
Figure 12.	r_{ON} vs I_{SW} vs Temperature, $V_{SWI} = 5.5V$ (PSpice Results)	7
Figure 13.	r_{ON} vs I_{SW} vs Temperature, $V_{SWI} = 5.5V$ (Characterization Results)	7
Figure 14.	Turn-On Waveform, 3V, $C_L = 310.5\mu F$ (PSpice Results)	8
Figure 15.	Turn-On Waveform, 3V, $C_L = 310.5\mu F$ (Characterization Results)	8
Figure 16.	Turn-Off Waveform, 3V, $C_L = 310.5\mu F$ (PSpice Results)	8

Figure 17. Turn-Off Waveform, 3V, $C_L = 310.5\mu\text{F}$ (Characterization Results)	8
Figure 18. Turn-On Waveform, 5.5V, $C_L = 310.5\mu\text{F}$ (PSpice Results)	9
Figure 19. Turn-On Waveform, 5.5V, $C_L = 310.5\mu\text{F}$ (Characterization Results)	9
Figure 20. Turn-Off Waveform, 5.5V, $C_L = 310.5\mu\text{F}$ (PSpice Results)	9
Figure 21. Turn-Off Waveform, 5.5V, $C_L = 310.5\mu\text{F}$ (Characterization Results)	9
Figure 22. Turn-On Waveform, 3V, $C_L = 10.1\mu\text{F}$ (PSpice Results)	9
Figure 23. Turn-On Waveform, 3V, $C_L = 10.1\mu\text{F}$ (Characterization Results)	9
Figure 24. Turn-Off Waveform, 3V, $C_L = 10.1\mu\text{F}$ (PSpice Results)	10
Figure 25. Turn-Off Waveform, 3V, $C_L = 10.1\mu\text{F}$ (Characterization Results)	10
Figure 26. Turn-On Waveform, 5.5V, $C_L = 10.1\mu\text{F}$ (PSpice Results)	10
Figure 27. Turn-On Waveform, 5.5V, $C_L = 10.1\mu\text{F}$ (Characterization Results)	10
Figure 28. Turn-Off Waveform, 5.5V, $C_L = 10.1\mu\text{F}$ (PSpice Results)	10
Figure 29. Turn-Off Waveform, 5.5V, $C_L = 10.1\mu\text{F}$ (Characterization Results)	10
Figure 30. I_{RCP} Enter vs V_{SWO} vs Temperature, 5.5V (PSpice Results)	11
Figure 31. I_{RCP} Enter vs V_{SWO} vs Temperature, 5.5V (Characterization Results)	11

Related Literature

For a full list of related documents, visit our website:

- [ISL70061SEH](#) and [ISL73061SEH](#) device pages

1. PSpice General Functional Test Simulation

The simulation shown in [Figure 3](#) shows how the ISL70061SEH PSpice model replicates the load switch functionality for basic on/off control, UVLO, the selectable discharge MOSFET feature, and slow turn-on controlled rise time.

1.1 ISL70061SEH.LIB and ISL70061SEH.OLB PSpice Files

The PSpice ISL70061SEH.LIB and ISL70061SEH.OLB files can be downloaded from the Renesas website at the ISL70061SEH and ISL73061SEH device pages on the **Download** tab. The file path to the ISL70061SEH.OLB sub-circuit ([Figure 1](#)) must be added to the Cadence parts placement tool. Then it can be used in simulation schematics. The ISL70061SEH.LIB file path must be added to the Cadence simulation profile as shown in [Figure 2](#). The Renesas group uses Cadence Allegro Design Entry CIS 16.6-S071 (v16-6-112FZ).

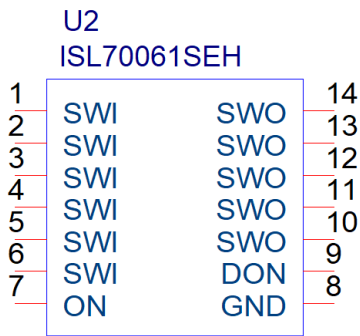

Figure 1. ISL70061SEH Sub-Circuit (ISL70061SEH.OLB)

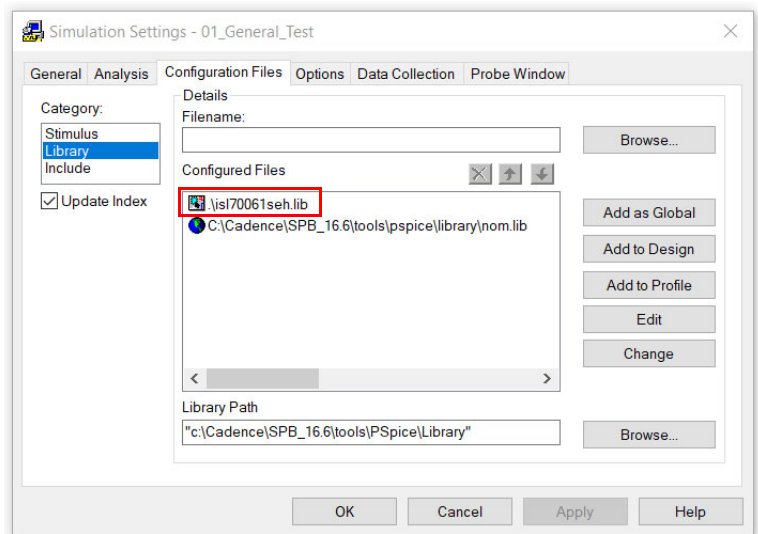

Figure 2. ISL70061SEH.LIB

1.2 Functional Simulation Schematic

[Figure 3](#) below shows the PSpice simulation schematic used for the functional simulation test.

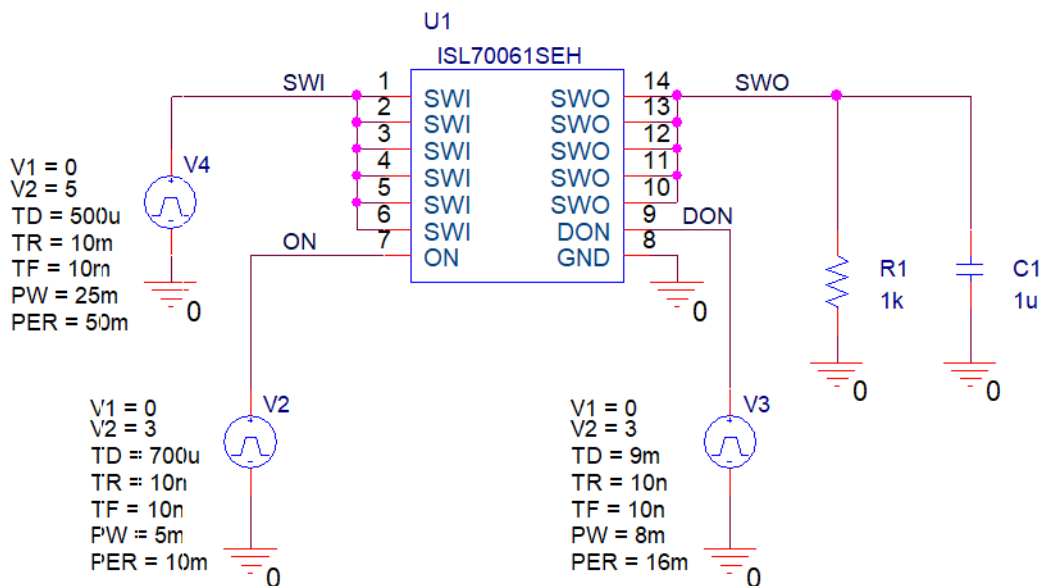

Figure 3. ISL70061SEH PSpice General Functional Test Schematic

1.3 Functional Simulation Results

The time-domain transient simulation results for the functional test is shown in [Figure 4](#). There are plots for SWI (blue trace), DON (red trace), ON (green trace) and SWO (black trace) vs Time. The functional states of the load switch are indicated by the numbers 1-6 on the SWO plot. The functional state relates to the numbers 1-6 as follows:

1. The part is in the UVLO off state. Because SWI voltage is below the UVLO falling threshold of 2.2V, the switch is OFF even though ON = High.
 2. When the SWI voltage reaches the UVLO rising threshold voltage of 2.3V, the part is no longer in the UVLO state and because ON = High the switch turns ON.
 3. ON = Low and the switch turns OFF. The output slowly decays to ground. The 1kΩ load resistor with the 1μF load capacitance connected at the output slowly decays the output to ground.
- Note:** DON = Low (discharge MOSFET circuitry is disabled).
4. ON = High and the switch turns ON with a controlled rise time of $\approx 600\mu\text{s}$.
 5. DON = High (discharge MOSFET circuitry is enabled), ON = Low: The switch turns OFF. The internal 122Ω discharge resistor quickly discharges the output to ground.
 6. The part enters the UVLO off state. Because SWI voltage is below the UVLO falling threshold voltage of 2.2V, the switch is OFF even though ON = High.

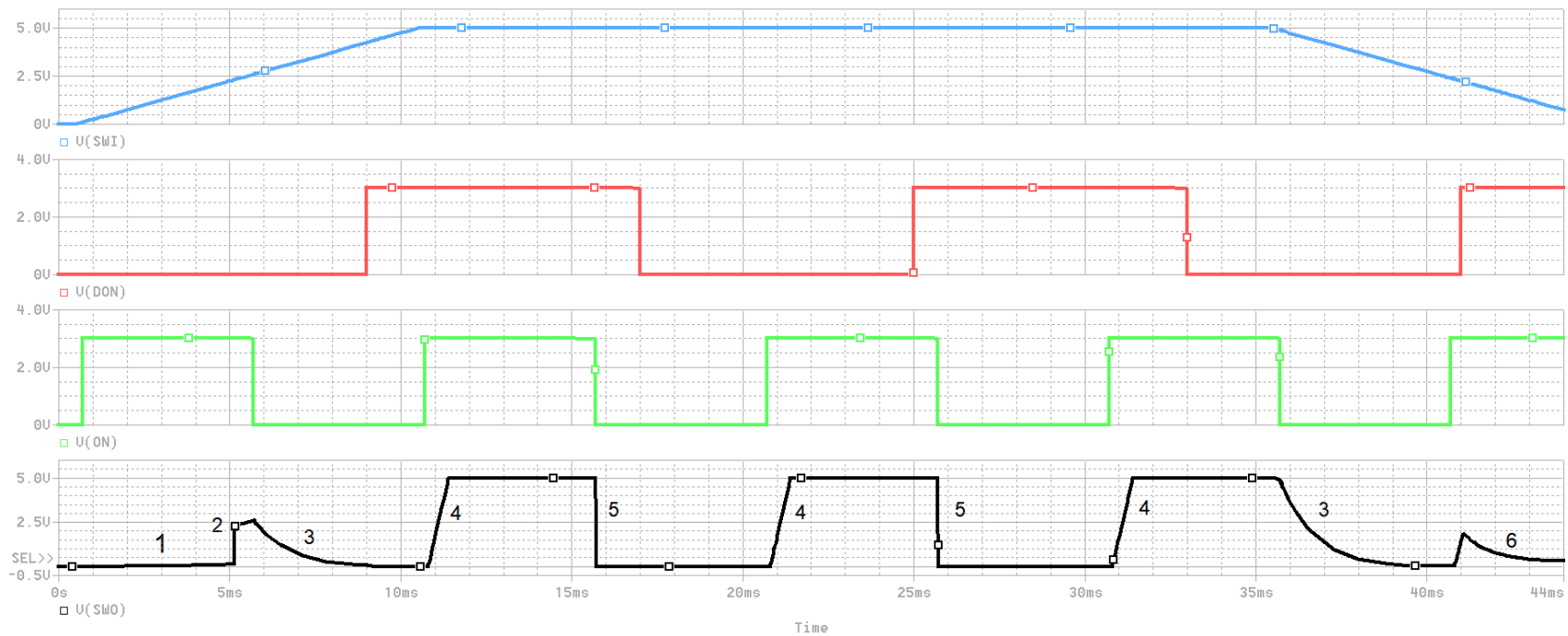

Figure 4. ISL70061SEH PSpice General Functional Simulation Results

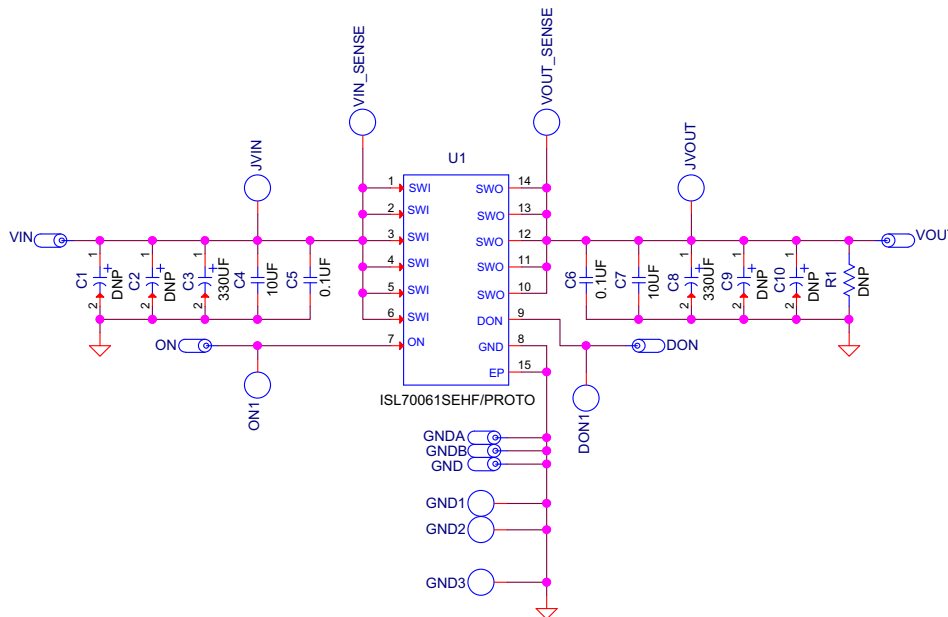

Figure 5. ISL70061SEHEV1Z Rev. A Evaluation Board Schematic

2. PSpice Simulation Results Verses Characterization Test Results

The ISL70061SEH PSpice model is designed to meet the typical values across temperature of the specification parameters in the ISL70061SEH datasheet. PSpice simulations closely match the typical performance curves in the datasheet. This section, for a few parameters, provides a comparison between the PSpice simulation results and actual part characterization test results.

Figure 6 through Figure 31 shows the PSpice simulation results vs the load switch characterization test results for r_{ON} vs V_{SWI} , r_{ON} vs I_{SW} , turn-on and turn-off timing, and the RCP enter response.

For a particular parameter, the graph on the left is the PSpice simulation result and the graph on the right is the characterization result. For example, Figure 6 is the PSpice result and Figure 7 is the characterization result for r_{ON} vs V_{SWI} vs temperature with $I_{SWO} = 1A$. You can quickly compare the graphs to see how the PSpice simulation result correlates with the characterization test result.

2.1 r_{ON} vs V_{SWI} vs Temperature

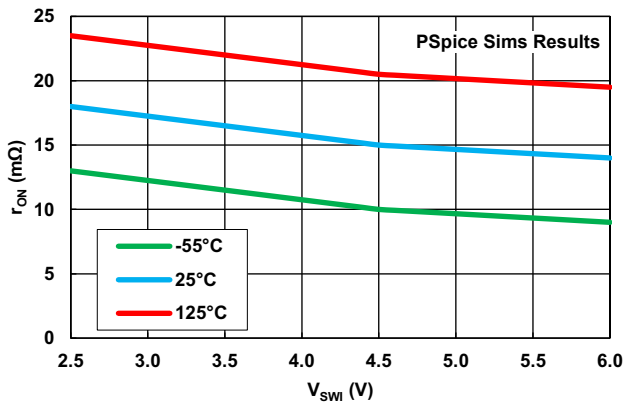

Figure 6. r_{ON} vs V_{SWI} vs Temperature, $I_{SW} = 1A$ (PSpice Results)

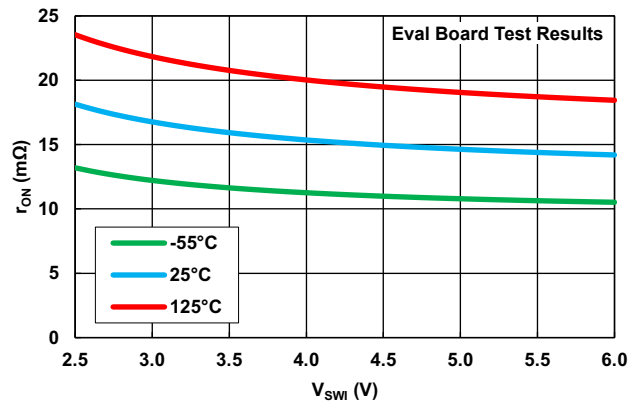

Figure 7. r_{ON} vs V_{SWI} vs Temperature, $I_{SW} = 1A$ (Characterization Results)

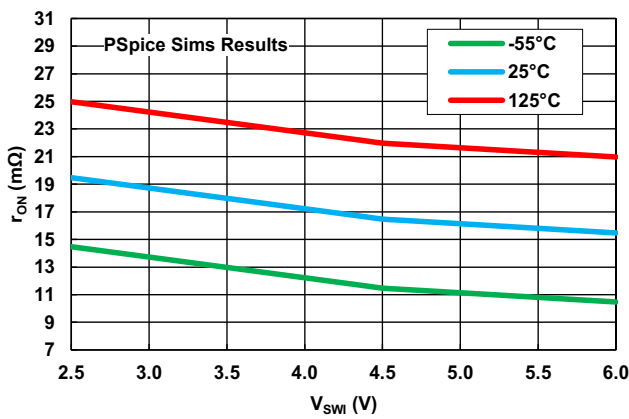

Figure 8. r_{ON} vs V_{SWI} vs Temperature, $I_{SW} = 3A$ (PSpice Results)

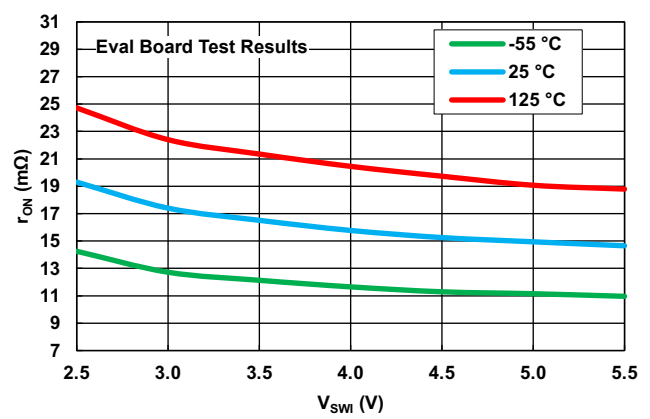

Figure 9. r_{ON} vs V_{SWI} vs Temperature, $I_{SW} = 3A$ (Characterization Results)

2.2 r_{ON} vs I_{SW} vs Temperature

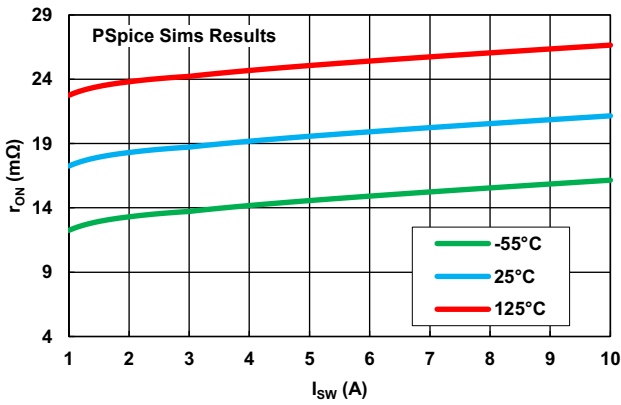

Figure 10. r_{ON} vs I_{SW} vs Temperature, $V_{SWI} = 3V$ (PSpice Results)

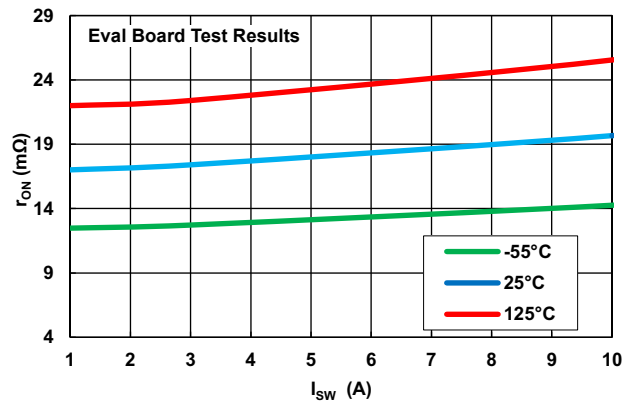

Figure 11. r_{ON} vs I_{SW} vs Temperature, $V_{SWI} = 3V$ (Characterization Results)

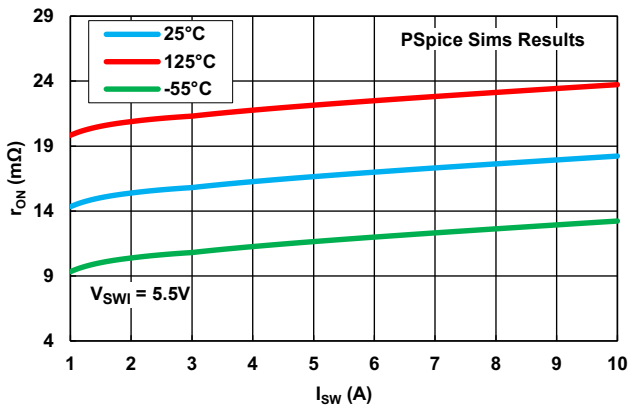

Figure 12. r_{ON} vs I_{SW} vs Temperature, $V_{SWI} = 5.5V$ (PSpice Results)

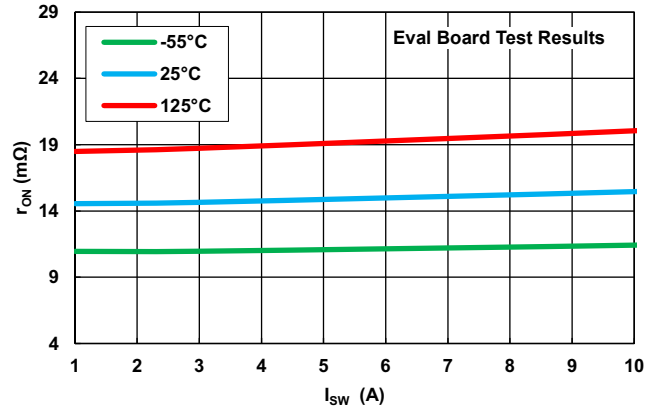

Figure 13. r_{ON} vs I_{SW} vs Temperature, $V_{SWI} = 5.5V$ (Characterization Results)

2.3 Turn-ON and Turn-OFF Waveforms

The ISL70061SEHEV1Z evaluation board schematic (Figure 5) has 300µF//10µF//0.1µF capacitors at the SWI input and has 0.1µF//10µF//300µF at the SWO output. Figure 14 through Figure 21 show the PSpice simulation vs evaluation board turn-on and turn-off test results with the 300µF//10µF//0.1µF capacitors. Figure 22 through Figure 29 show the PSpice simulation vs evaluation board test results with the 300µF capacitor removed leaving the 10µF//0.1µF capacitors installed at both the SWI input and SWO input.

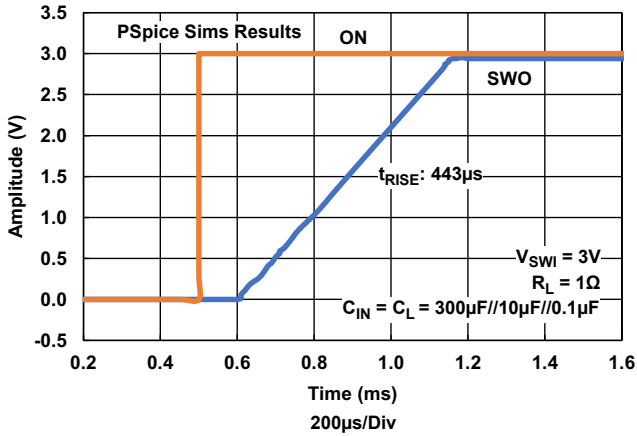

Figure 14. Turn-On Waveform, 3V, $C_L = 310.5\mu\text{F}$ (PSpice Results)

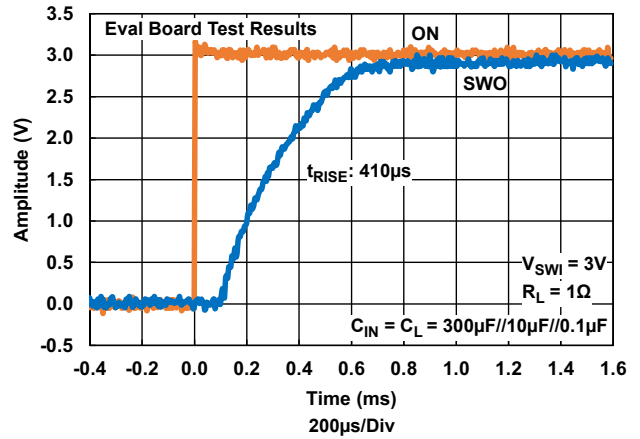

Figure 15. Turn-On Waveform, 3V, $C_L = 310.5\mu\text{F}$ (Characterization Results)

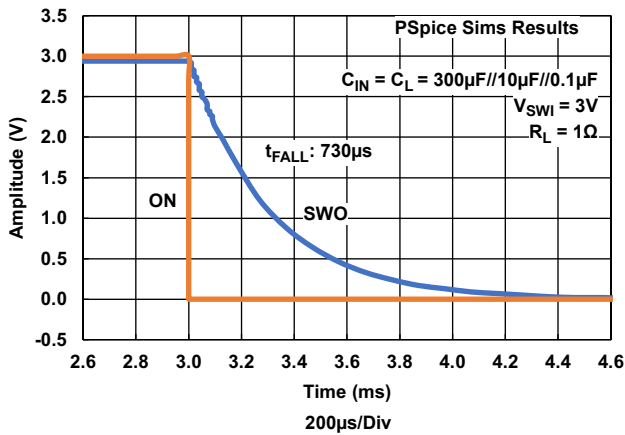

Figure 16. Turn-Off Waveform, 3V, $C_L = 310.5\mu\text{F}$ (PSpice Results)

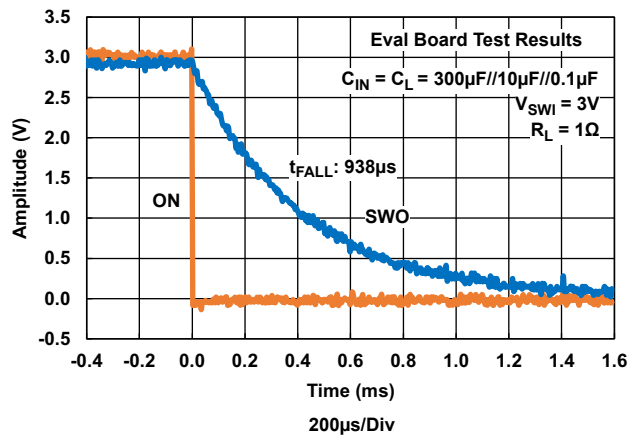

Figure 17. Turn-Off Waveform, 3V, $C_L = 310.5\mu\text{F}$ (Characterization Results)

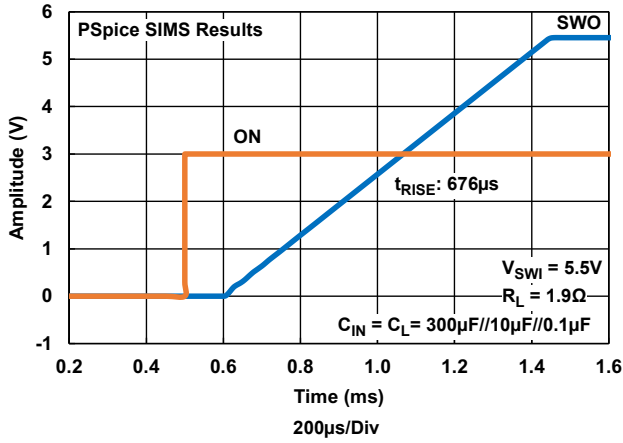

Figure 18. Turn-On Waveform, 5.5V, $C_L = 310.5\mu F$ (PSpice Results)

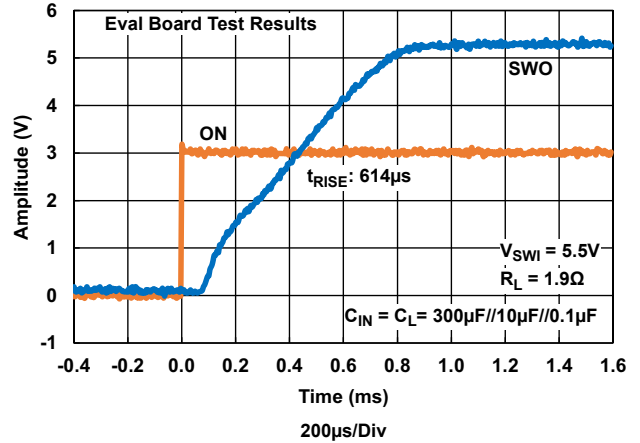

Figure 19. Turn-On Waveform, 5.5V, $C_L = 310.5\mu F$ (Characterization Results)

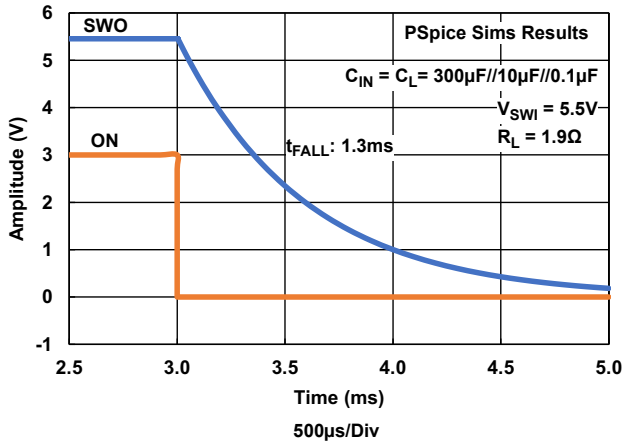

Figure 20. Turn-Off Waveform, 5.5V, $C_L = 310.5\mu F$ (PSpice Results)

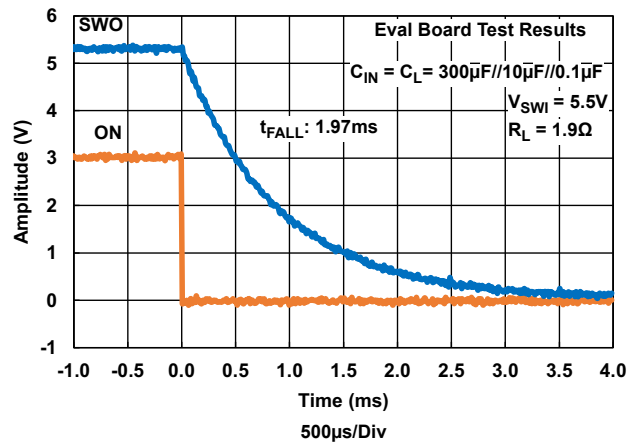

Figure 21. Turn-Off Waveform, 5.5V, $C_L = 310.5\mu F$ (Characterization Results)

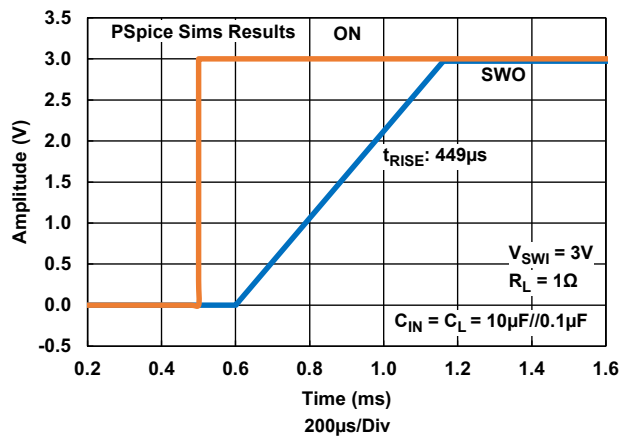

Figure 22. Turn-On Waveform, 3V, $C_L = 10.1\mu F$ (PSpice Results)

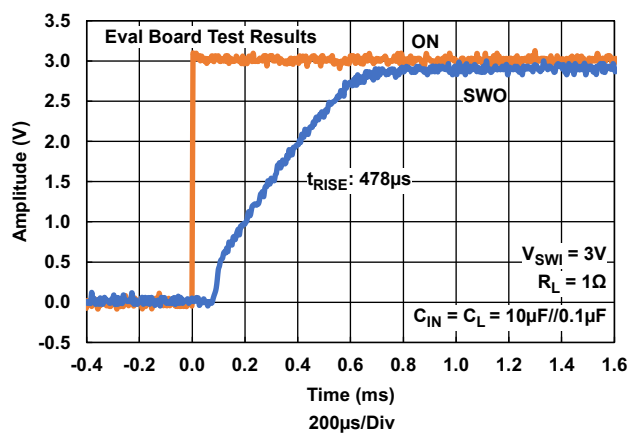

Figure 23. Turn-On Waveform, 3V, $C_L = 10.1\mu F$ (Characterization Results)

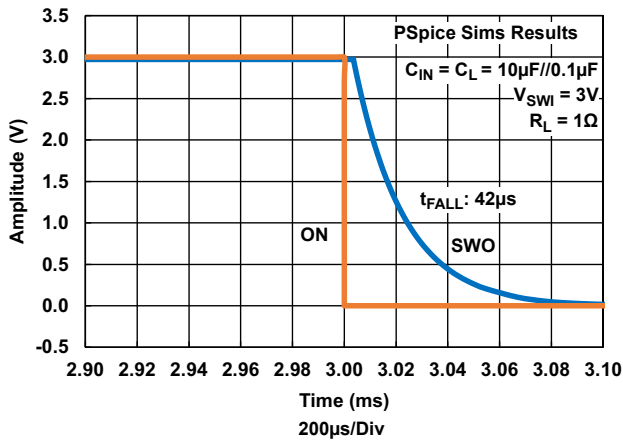

Figure 24. Turn-Off Waveform, 3V, $C_L = 10.1\mu\text{F}$ (PSpice Results)

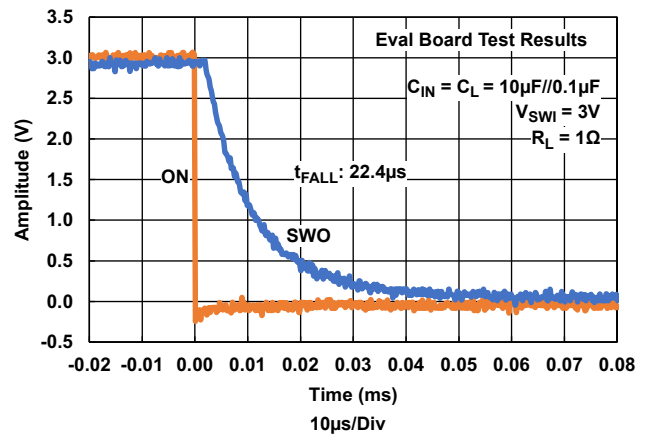

Figure 25. Turn-Off Waveform, 3V, $C_L = 10.1\mu\text{F}$ (Characterization Results)

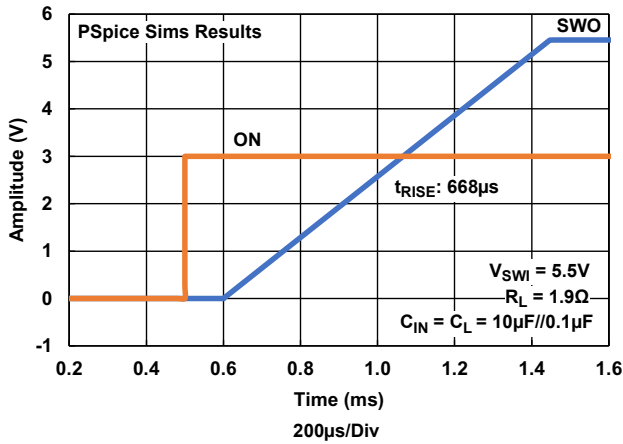

Figure 26. Turn-On Waveform, 5.5V, $C_L = 10.1\mu\text{F}$ (PSpice Results)

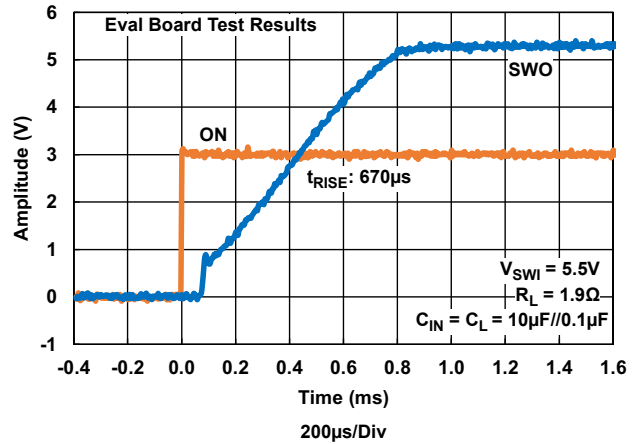

Figure 27. Turn-On Waveform, 5.5V, $C_L = 10.1\mu\text{F}$ (Characterization Results)

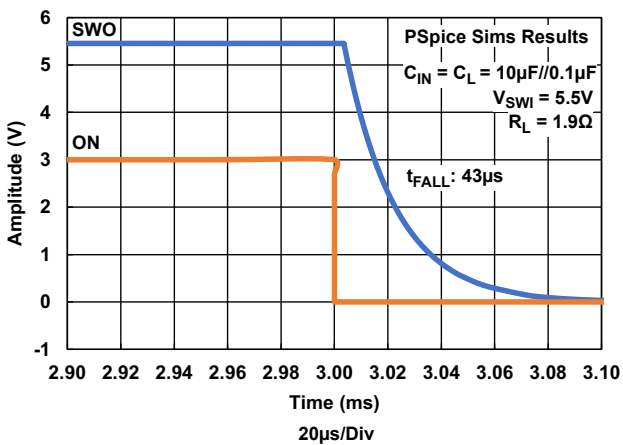

Figure 28. Turn-Off Waveform, 5.5V, $C_L = 10.1\mu\text{F}$ (PSpice Results)

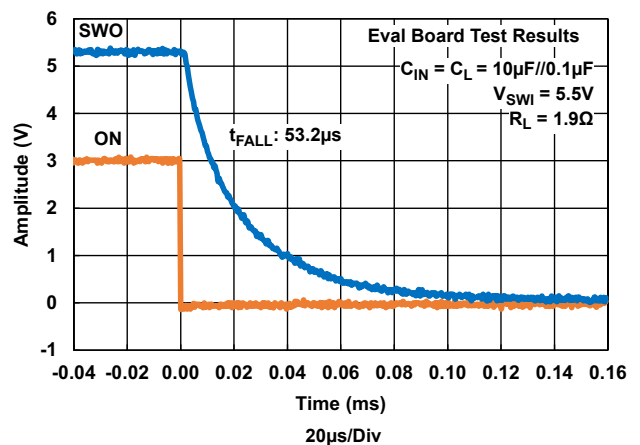

Figure 29. Turn-Off Waveform, 5.5V, $C_L = 10.1\mu\text{F}$ (Characterization Results)

2.4 Reverse Current Protection (RCP) Waveforms

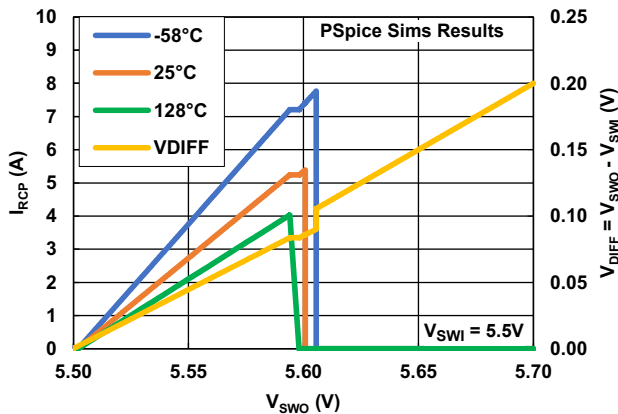

Figure 30. I_{RCP} Enter vs V_{SWO} vs Temperature, 5.5V (PSpice Results)

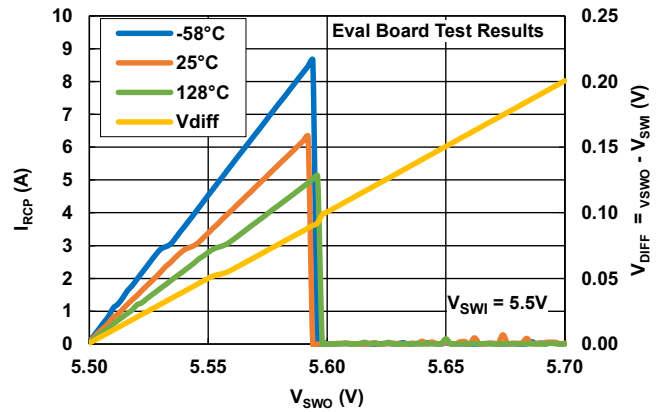

Figure 31. I_{RCP} Enter vs V_{SWO} vs Temperature, 5.5V (Characterization Results)

2.5 Conclusion

The ISL70061SEH PSpice model replicates the functionality of the ISL70061SEH load switch. It closely matches the characterization curves in the ISL70061SEH datasheet and meets the typical values across temperature of the parameters in the datasheet specification table.

3. Revision History

Rev.	Date	Description
1.00	Jan.6.20	Initial release

Notice

1. Descriptions of circuits, software and other related information in this document are provided only to illustrate the operation of semiconductor products and application examples. You are fully responsible for the incorporation or any other use of the circuits, software, and information in the design of your product or system. Renesas Electronics disclaims any and all liability for any losses and damages incurred by you or third parties arising from the use of these circuits, software, or information.
2. Renesas Electronics hereby expressly disclaims any warranties against and liability for infringement or any other claims involving patents, copyrights, or other intellectual property rights of third parties, by or arising from the use of Renesas Electronics products or technical information described in this document, including but not limited to, the product data, drawings, charts, programs, algorithms, and application examples.
3. No license, express, implied or otherwise, is granted hereby under any patents, copyrights or other intellectual property rights of Renesas Electronics or others.
4. You shall not alter, modify, copy, or reverse engineer any Renesas Electronics product, whether in whole or in part. Renesas Electronics disclaims any and all liability for any losses or damages incurred by you or third parties arising from such alteration, modification, copying or reverse engineering.
5. Renesas Electronics products are classified according to the following two quality grades: "Standard" and "High Quality". The intended applications for each Renesas Electronics product depends on the product's quality grade, as indicated below.
 - "Standard": Computers; office equipment; communications equipment; test and measurement equipment; audio and visual equipment; home electronic appliances; machine tools; personal electronic equipment; industrial robots; etc.
 - "High Quality": Transportation equipment (automobiles, trains, ships, etc.); traffic control (traffic lights); large-scale communication equipment; key financial terminal systems; safety control equipment; etc.Unless expressly designated as a high reliability product or a product for harsh environments in a Renesas Electronics data sheet or other Renesas Electronics document, Renesas Electronics products are not intended or authorized for use in products or systems that may pose a direct threat to human life or bodily injury (artificial life support devices or systems; surgical implantations; etc.), or may cause serious property damage (space system; undersea repeaters; nuclear power control systems; aircraft control systems; key plant systems; military equipment; etc.). Renesas Electronics disclaims any and all liability for any damages or losses incurred by you or any third parties arising from the use of any Renesas Electronics product that is inconsistent with any Renesas Electronics data sheet, user's manual or other Renesas Electronics document.
6. When using Renesas Electronics products, refer to the latest product information (data sheets, user's manuals, application notes, "General Notes for Handling and Using Semiconductor Devices" in the reliability handbook, etc.), and ensure that usage conditions are within the ranges specified by Renesas Electronics with respect to maximum ratings, operating power supply voltage range, heat dissipation characteristics, installation, etc. Renesas Electronics disclaims any and all liability for any malfunctions, failure or accident arising out of the use of Renesas Electronics products outside of such specified ranges.
7. Although Renesas Electronics endeavors to improve the quality and reliability of Renesas Electronics products, semiconductor products have specific characteristics, such as the occurrence of failure at a certain rate and malfunctions under certain use conditions. Unless designated as a high reliability product or a product for harsh environments in a Renesas Electronics data sheet or other Renesas Electronics document, Renesas Electronics products are not subject to radiation resistance design. You are responsible for implementing safety measures to guard against the possibility of bodily injury, injury or damage caused by fire, and/or danger to the public in the event of a failure or malfunction of Renesas Electronics products, such as safety design for hardware and software, including but not limited to redundancy, fire control and malfunction prevention, appropriate treatment for aging degradation or any other appropriate measures. Because the evaluation of microcomputer software alone is very difficult and impractical, you are responsible for evaluating the safety of the final products or systems manufactured by you.
8. Please contact a Renesas Electronics sales office for details as to environmental matters such as the environmental compatibility of each Renesas Electronics product. You are responsible for carefully and sufficiently investigating applicable laws and regulations that regulate the inclusion or use of controlled substances, including without limitation, the EU RoHS Directive, and using Renesas Electronics products in compliance with all these applicable laws and regulations. Renesas Electronics disclaims any and all liability for damages or losses occurring as a result of your noncompliance with applicable laws and regulations.
9. Renesas Electronics products and technologies shall not be used for or incorporated into any products or systems whose manufacture, use, or sale is prohibited under any applicable domestic or foreign laws or regulations. You shall comply with any applicable export control laws and regulations promulgated and administered by the governments of any countries asserting jurisdiction over the parties or transactions.
10. It is the responsibility of the buyer or distributor of Renesas Electronics products, or any other party who distributes, disposes of, or otherwise sells or transfers the product to a third party, to notify such third party in advance of the contents and conditions set forth in this document.
11. This document shall not be reprinted, reproduced or duplicated in any form, in whole or in part, without prior written consent of Renesas Electronics.
12. Please contact a Renesas Electronics sales office if you have any questions regarding the information contained in this document or Renesas Electronics products.

(Note1) "Renesas Electronics" as used in this document means Renesas Electronics Corporation and also includes its directly or indirectly controlled subsidiaries.

(Note2) "Renesas Electronics product(s)" means any product developed or manufactured by or for Renesas Electronics.

(Rev.4.0-1 November 2017)

Corporate Headquarters

TOYOSU FORESIA, 3-2-24 Toyosu,
Koto-ku, Tokyo 135-0061, Japan
www.renesas.com

Contact Information

For further information on a product, technology, the most up-to-date version of a document, or your nearest sales office, please visit:
www.renesas.com/contact/

Trademarks

Renesas and the Renesas logo are trademarks of Renesas Electronics Corporation. All trademarks and registered trademarks are the property of their respective owners.