

Contents

1	Introduction.....	2
2	QFN24 (4x4mm) Package Marking.....	2
3	ZSSC3018 Pin Assignments and Layout.....	2
4	Thermal Resistance Value for the ZSSC3018 QFN24 Package	4
5	QFN24 (4x4mm) Package Dimensions.....	5
6	ZSSC3018 Footprint and Landing Pattern	6
7	Related Documents.....	7
8	Glossary	7
9	Document Revision History.....	7

List of Figures

Figure 3.1	Pin Layout for the ZSSC3018 QFN24 Package (4mm x 4mm).....	2
Figure 5.1	Package Dimensions for the ZSSC3018 QFN24 Package	5
Figure 6.1	Recommended Footprint for ZSSC3018 QFN24 Package	6
Figure 6.2	Recommended Landing Pattern for ZSSC3018 QFN24 Package	6

List of Tables

Table 2.1	QFN24 Package Marking	2
Table 3.1	ZSSC3018 Pin Assignments PQFN24	3
Table 4.1	ZSSC3018 Thermal Resistance	4
Table 5.1	QFN24 Dimensions (4mm x 4mm)	5

1 Introduction

The ZSSC3018 Sensor Signal Conditioner ICs is available in a RoHS-compliant QFN24 package (4mm x 4mm). This document provides details for package dimensions, pin assignments and layout, footprint, landing pattern, board connections, package marking, and thermal resistance.

2 QFN24 (4x4mm) Package Marking

Table 2.1 QFN24 Package Marking

Top Side		Comments
1 st Line	3018B	3018B = Product name
2 nd Line	YYWW	YY = Year (e.g., 15 for 2015, 16 for 2016, ...); WW = Workweek (e.g., 15)
3 rd Line	XXXXX	Last five digits of IDT lot number

3 ZSSC3018 Pin Assignments and Layout

Figure 3.1 shows the pin assignments of the QFN24 (4x4mm) package. This pin layout enables implementation of the recommended printed circuit board (PCB) design. See section 5 for specific dimensions.

Figure 3.1 Pin Layout for the ZSSC3018 QFN24 Package (4mm x 4mm)

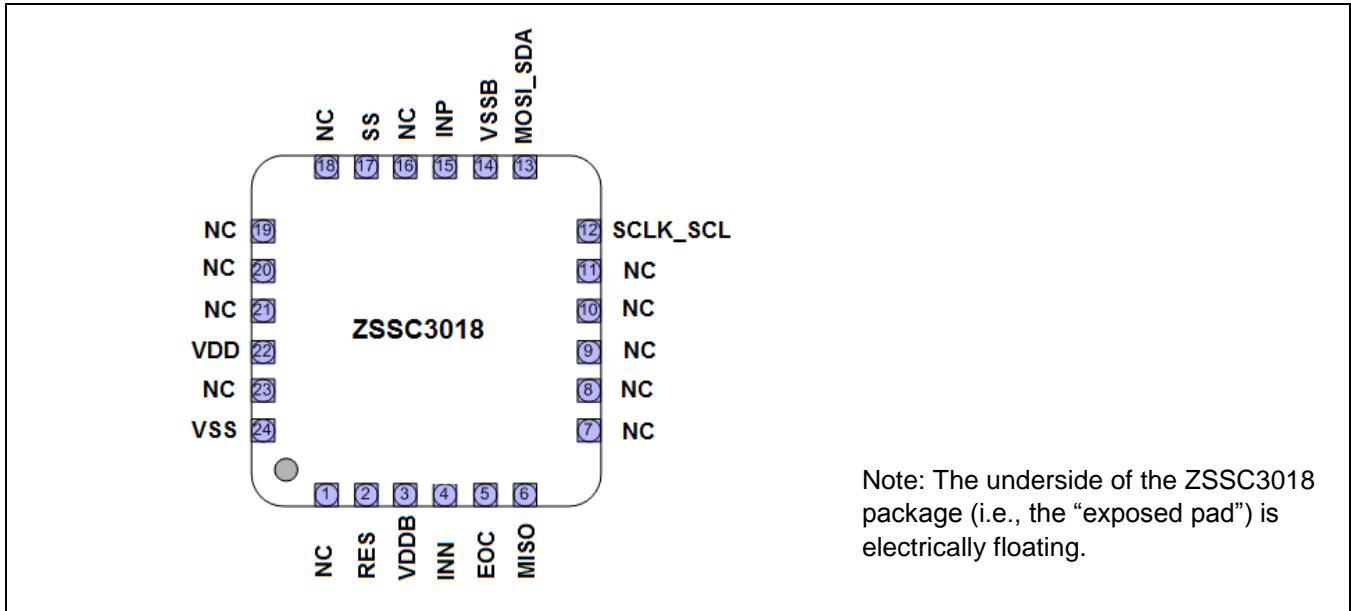

Table 3.1 ZSSC3018 Pin Assignments PQFN24

Note: In the following table, “n.c.” stands for not connected / no connection required / not bonded.

Pin No.	Name	Direction	Type	Description
1	test1	-	-	Do not connect.
2	RES	In	Digital	ZSSC3018 reset (low active, internal pull-up).
3	VDDB	Out	Analog	Positive external bridge-sensor supply.
4	INN	In	Analog	Negative sensor signal (or sensor ground for absolute voltage-source sensors).
5	EOC	Out	Digital	End of conversion or interrupt output.
6	MISO	Out	Digital	Data output for SPI.
7	test7	-	-	Do not connect.
8	n.c.	-	-	-
9	n.c.	-	-	-
10	n.c.	-	-	-
11	n.c.	-	-	-
12	SCLK_SCL	In	Digital	Clock input for SPI/I ² C.
13	MOSI_SDA	In/Out	Digital	Data input for SPI; data in/out for I ² C.
14	VSSB	Out	Analog	Negative external bridge-sensor supply (sensor ground).
15	INP	In	Analog	Positive sensor signal.
16	test16	-	-	Do not connect.
17	SS	In	Digital	Slave select for SPI.
18	test18	-	-	Do not connect.
19	test19	-	-	Do not connect.
20	n.c.	-	-	-
21	n.c.	-	-	-
22	VDD	In	Supply	IC positive supply voltage for the ZSSC3018.
23	n.c.	-	-	-
24	VSS	In	Supply	Ground reference voltage signal.
25	Exposed pad	-	-	Do not connect electrically.

4 Thermal Resistance Value for the ZSSC3018 QFN24 Package

The QFN24 (4x4mm) package has a junction-to-ambient θ_{JA} of 31.8 °C/W.

θ_{JA} has been simulated in accordance to following JEDEC-standards:

- Test Board Design as per JESD51-7.
- Natural Convection Test Conditions as per JESD51-2.

Table 4.1 ZSSC3018 Thermal Resistance

Parameter	Symbol	Value	Unit
Thermal Resistance – junction to ambient	θ_{JA}	31.8	°C/W

5 QFN24 (4x4mm) Package Dimensions

Figure 5.1 and Table 5.1 show the package drawing and parameters for the ZSSC3018 QFN24 (4x4mm) package based on JEDEC MO-220. Dimensions are in millimeters.

Figure 5.1 Package Dimensions for the ZSSC3018 QFN24 Package

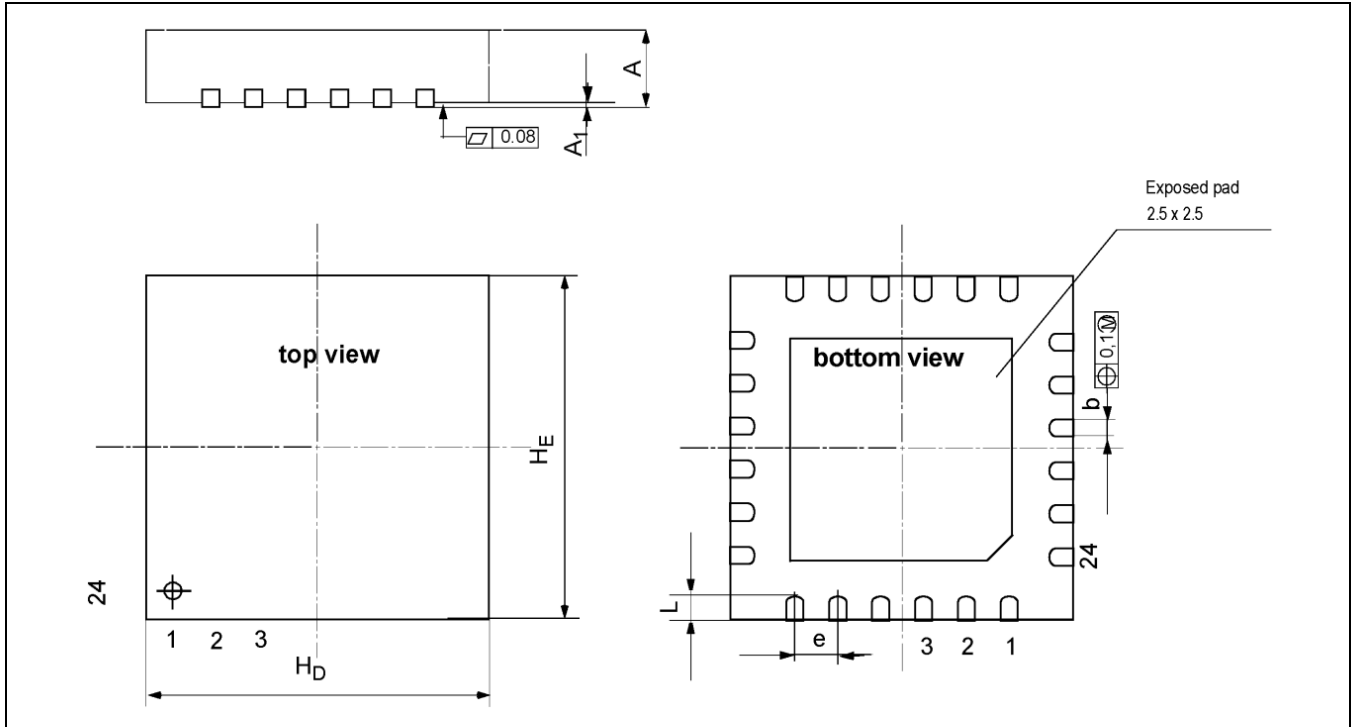

Table 5.1 QFN24 Dimensions (4mm x 4mm)

Dimension Limit	MIN	NOM	MAX
A	0.80		0.90
A ₁	0.00		0.05
b	0.20		0.30
e		0.50	
H _D	3.90		4.10
H _E	3.90		4.10
L	0.30		0.50

6 ZSSC3018 Footprint and Landing Pattern

Figure 6.1 illustrates a recommended footprint for PCB designs using the ZSSC3018 QFN24 package.

- The exposed area of the landing pattern is 0.25mm from the unit edge.
- The stencil opening excess is approximately 0.2mm from the landing pattern.

IDT also provides electronic data on its website (www.IDT.com/zssc3018).

Figure 6.1 Recommended Footprint for ZSSC3018 QFN24 Package

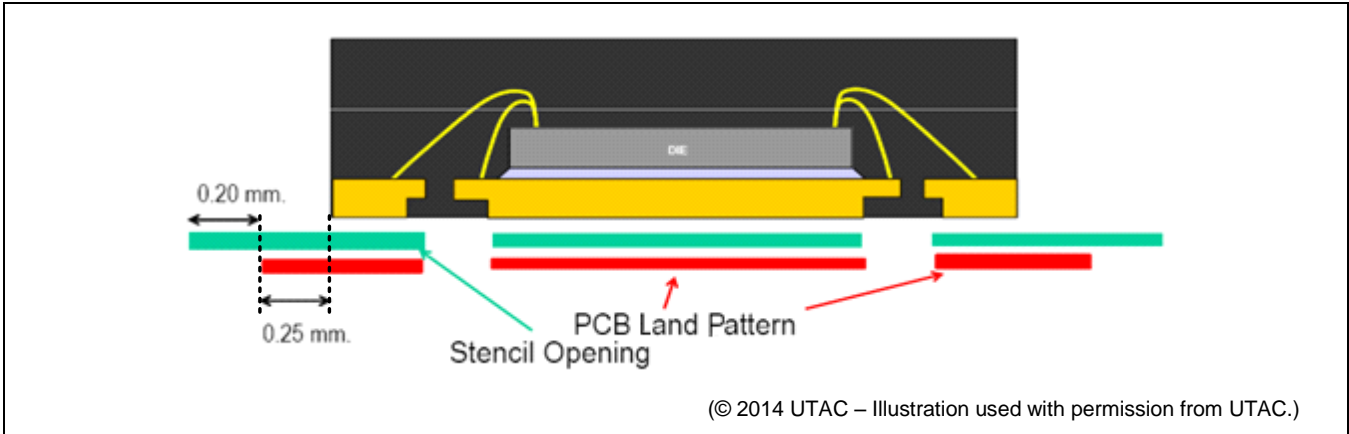
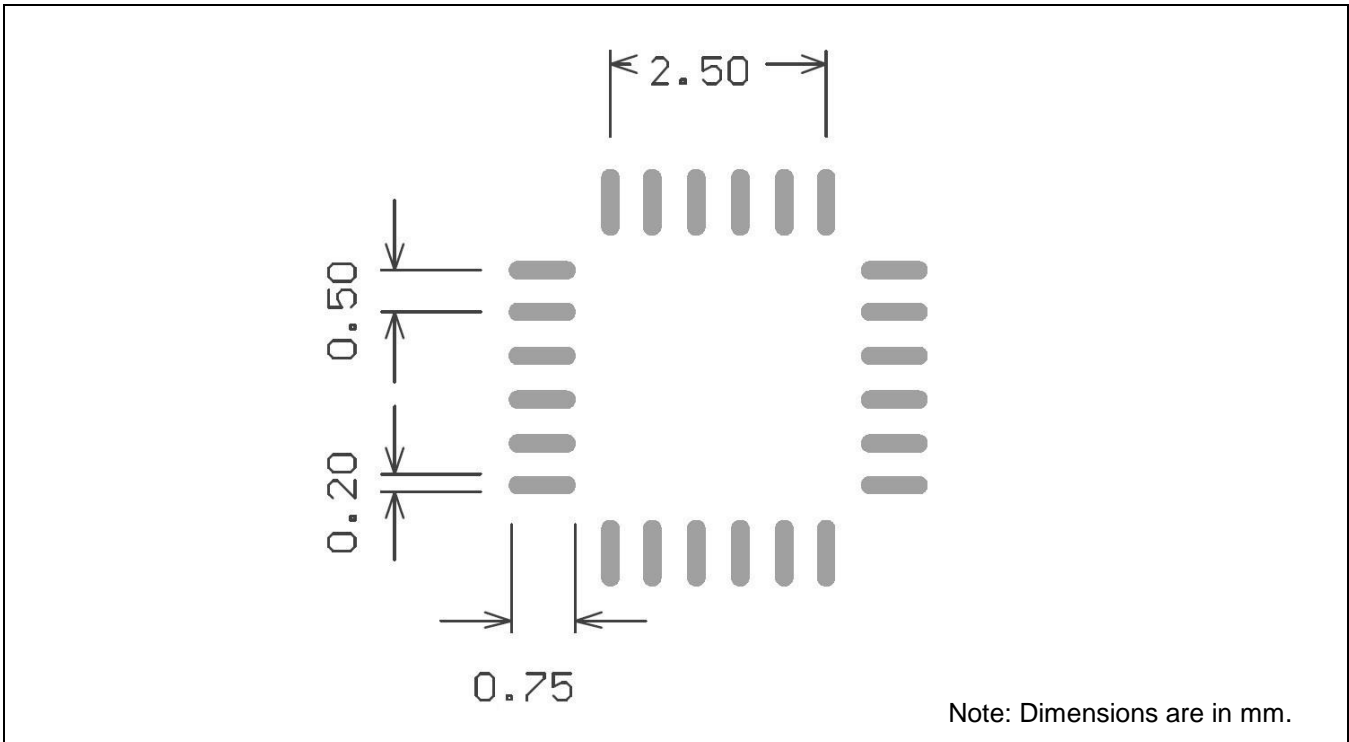

Figure 6.2 illustrates the recommended landing pattern for the ZSSC3018 QFN24 package.

Figure 6.2 Recommended Landing Pattern for ZSSC3018 QFN24 Package



7 Related Documents

Document
ZSSC3018 Data Sheet
ZSSC3018 Evaluation Kit Description

Visit the ZSSC3018 product page at www.IDT.com/ZSSC3018 or contact your nearest sales office for ordering information or the latest version of these documents.

8 Glossary

Term	Description
PCB	Printed Circuit Board
QFN	Quad Flat No Leads Package
SSC	Sensor Signal Conditioner

9 Document Revision History

Revision	Date	Description
160601	June 1, 2016	First release.

Notice

1. Descriptions of circuits, software and other related information in this document are provided only to illustrate the operation of semiconductor products and application examples. You are fully responsible for the incorporation or any other use of the circuits, software, and information in the design of your product or system. Renesas Electronics disclaims any and all liability for any losses and damages incurred by you or third parties arising from the use of these circuits, software, or information.
 2. Renesas Electronics hereby expressly disclaims any warranties against and liability for infringement or any other claims involving patents, copyrights, or other intellectual property rights of third parties, by or arising from the use of Renesas Electronics products or technical information described in this document, including but not limited to, the product data, drawings, charts, programs, algorithms, and application examples.
 3. No license, express, implied or otherwise, is granted hereby under any patents, copyrights or other intellectual property rights of Renesas Electronics or others.
 4. You shall be responsible for determining what licenses are required from any third parties, and obtaining such licenses for the lawful import, export, manufacture, sales, utilization, distribution or other disposal of any products incorporating Renesas Electronics products, if required.
 5. You shall not alter, modify, copy, or reverse engineer any Renesas Electronics product, whether in whole or in part. Renesas Electronics disclaims any and all liability for any losses or damages incurred by you or third parties arising from such alteration, modification, copying or reverse engineering.
 6. Renesas Electronics products are classified according to the following two quality grades: "Standard" and "High Quality". The intended applications for each Renesas Electronics product depends on the product's quality grade, as indicated below.
 - "Standard": Computers; office equipment; communications equipment; test and measurement equipment; audio and visual equipment; home electronic appliances; machine tools; personal electronic equipment; industrial robots; etc.
 - "High Quality": Transportation equipment (automobiles, trains, ships, etc.); traffic control (traffic lights); large-scale communication equipment; key financial terminal systems; safety control equipment; etc.
- Unless expressly designated as a high reliability product or a product for harsh environments in a Renesas Electronics data sheet or other Renesas Electronics document, Renesas Electronics products are not intended or authorized for use in products or systems that may pose a direct threat to human life or bodily injury (artificial life support devices or systems; surgical implantations; etc.), or may cause serious property damage (space system; undersea repeaters; nuclear power control systems; aircraft control systems; key plant systems; military equipment; etc.). Renesas Electronics disclaims any and all liability for any damages or losses incurred by you or any third parties arising from the use of any Renesas Electronics product that is inconsistent with any Renesas Electronics data sheet, user's manual or other Renesas Electronics document.
7. No semiconductor product is absolutely secure. Notwithstanding any security measures or features that may be implemented in Renesas Electronics hardware or software products, Renesas Electronics shall have absolutely no liability arising out of any vulnerability or security breach, including but not limited to any unauthorized access to or use of a Renesas Electronics product or a system that uses a Renesas Electronics product. RENESAS ELECTRONICS DOES NOT WARRANT OR GUARANTEE THAT RENESAS ELECTRONICS PRODUCTS, OR ANY SYSTEMS CREATED USING RENESAS ELECTRONICS PRODUCTS WILL BE INVULNERABLE OR FREE FROM CORRUPTION, ATTACK, VIRUSES, INTERFERENCE, HACKING, DATA LOSS OR THEFT, OR OTHER SECURITY INTRUSION ("Vulnerability Issues"). RENESAS ELECTRONICS DISCLAIMS ANY AND ALL RESPONSIBILITY OR LIABILITY ARISING FROM OR RELATED TO ANY VULNERABILITY ISSUES. FURTHERMORE, TO THE EXTENT PERMITTED BY APPLICABLE LAW, RENESAS ELECTRONICS DISCLAIMS ANY AND ALL WARRANTIES, EXPRESS OR IMPLIED, WITH RESPECT TO THIS DOCUMENT AND ANY RELATED OR ACCOMPANYING SOFTWARE OR HARDWARE, INCLUDING BUT NOT LIMITED TO THE IMPLIED WARRANTIES OF MERCHANTABILITY, OR FITNESS FOR A PARTICULAR PURPOSE.
 8. When using Renesas Electronics products, refer to the latest product information (data sheets, user's manuals, application notes, "General Notes for Handling and Using Semiconductor Devices" in the reliability handbook, etc.), and ensure that usage conditions are within the ranges specified by Renesas Electronics with respect to maximum ratings, operating power supply voltage range, heat dissipation characteristics, installation, etc. Renesas Electronics disclaims any and all liability for any malfunctions, failure or accident arising out of the use of Renesas Electronics products outside of such specified ranges.
 9. Although Renesas Electronics endeavors to improve the quality and reliability of Renesas Electronics products, semiconductor products have specific characteristics, such as the occurrence of failure at a certain rate and malfunctions under certain use conditions. Unless designated as a high reliability product or a product for harsh environments in a Renesas Electronics data sheet or other Renesas Electronics document, Renesas Electronics products are not subject to radiation resistance design. You are responsible for implementing safety measures to guard against the possibility of bodily injury, injury or damage caused by fire, and/or danger to the public in the event of a failure or malfunction of Renesas Electronics products, such as safety design for hardware and software, including but not limited to redundancy, fire control and malfunction prevention, appropriate treatment for aging degradation or any other appropriate measures. Because the evaluation of microcomputer software alone is very difficult and impractical, you are responsible for evaluating the safety of the final products or systems manufactured by you.
 10. Please contact a Renesas Electronics sales office for details as to environmental matters such as the environmental compatibility of each Renesas Electronics product. You are responsible for carefully and sufficiently investigating applicable laws and regulations that regulate the inclusion or use of controlled substances, including without limitation, the EU RoHS Directive, and using Renesas Electronics products in compliance with all these applicable laws and regulations. Renesas Electronics disclaims any and all liability for damages or losses occurring as a result of your noncompliance with applicable laws and regulations.
 11. Renesas Electronics products and technologies shall not be used for or incorporated into any products or systems whose manufacture, use, or sale is prohibited under any applicable domestic or foreign laws or regulations. You shall comply with any applicable export control laws and regulations promulgated and administered by the governments of any countries asserting jurisdiction over the parties or transactions.
 12. It is the responsibility of the buyer or distributor of Renesas Electronics products, or any other party who distributes, disposes of, or otherwise sells or transfers the product to a third party, to notify such third party in advance of the contents and conditions set forth in this document.
 13. This document shall not be reprinted, reproduced or duplicated in any form, in whole or in part, without prior written consent of Renesas Electronics.
 14. Please contact a Renesas Electronics sales office if you have any questions regarding the information contained in this document or Renesas Electronics products.

(Note1) "Renesas Electronics" as used in this document means Renesas Electronics Corporation and also includes its directly or indirectly controlled subsidiaries.

(Note2) "Renesas Electronics product(s)" means any product developed or manufactured by or for Renesas Electronics.

(Disclaimer Rev.5.0-1)

Corporate Headquarters

TOYOSU FORESIA, 3-2-24 Toyosu,
Koto-ku, Tokyo 135-0061, Japan
www.renesas.com

Trademarks

Renesas and the Renesas logo are trademarks of Renesas Electronics Corporation. All trademarks and registered trademarks are the property of their respective owners.

Contact Information

For further information on a product, technology, the most up-to-date version of a document, or your nearest sales office, please visit:
www.renesas.com/contact/