

RENESAS TECHNICAL UPDATE

TOYOSU FORESIA, 3-2-24, Toyosu, Koto-ku, Tokyo 135-0061, Japan
Renesas Electronics Corporation

Product Category	System LSI		Document No.	TN-RCV-A0001A/E	Rev.	1.00
Title	R-CarV3M Addition of section 19:Booting		Information Category	Technical Notification		
Applicable Product	R-Car V3M (R8A77970)	Lot No.	Reference Document	R-Car V3M R-Car Series 3rd Generation User's Manual: Rev.3.50 Jan 25, 2022 (R19UH0114EJ0350)		
		All Lots				

[Summary]

Addition of section 19:Booting

[Priority level]

Importance: "Normal"

Urgency: "Normal"

[Web publication]

N/A

[Rank] (ex. F:Limitation/Change, T:Extension/Addition/Correction)

T : Addition

“This is empty adjustment page to compare next Current (from) and Correction (to) on facing page. “

(By using two pages view of PDF readers this enables previously and prospectively view on odd and even pages.)

[Correction]

Current (from):

19.2 Operation

19.2.1 Boot Operation Overview

The boot address of the master boot processor is controlled by RESET module. It depends on boot device selection through MD[4:1] pins and AArch64/32 selection through MD15 pin.

If external ROM or XIP mode boot is selected, the processor can directly fetch from the target device. If the boot device except for external ROM and XIP mode is selected, the processor boots from on-chip Boot ROM and executes the boot sequence described “HyperFlash/Serial Flash ROM using DMA Boot sequence” section. 5KB or 3KB data are transferred from the target boot device to System RAM. Then IPL is transferred to System RAM. Then the processor jumps to the specified address.

If MD[4:1] reserved setting is selected, error message can be outputted via SCIF.

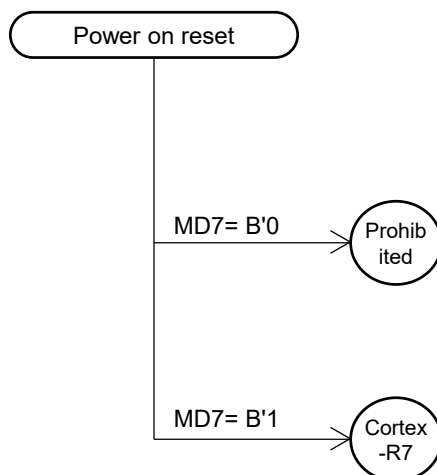

Figure 19.1 Master Boot processor selection

Correction (to):

19.2 Operation

19.2.1 Boot Operation Overview

The boot address of the master boot processor is controlled by RESET module. It depends on boot device selection through MD[4:1] pins and AArch64/32 selection through MD15 pin.

If external ROM or XIP mode boot is selected, the processor can directly fetch from the target device. If the boot device except for external ROM and XIP mode is selected, the processor boots from on-chip Boot ROM and executes the boot sequence described “HyperFlash/Serial Flash ROM using DMA Boot sequence” section. 5KB or 3KB data are transferred from the target boot device to System RAM. Then IPL is transferred to System RAM. Then the processor jumps to the specified address.

Notice : Because of RPC-IF restriction, CPU should read with 16Byte alignment to Hyperflash in XIP mode boot.

If MD[4:1] reserved setting is selected, error message can be outputted via SCIF

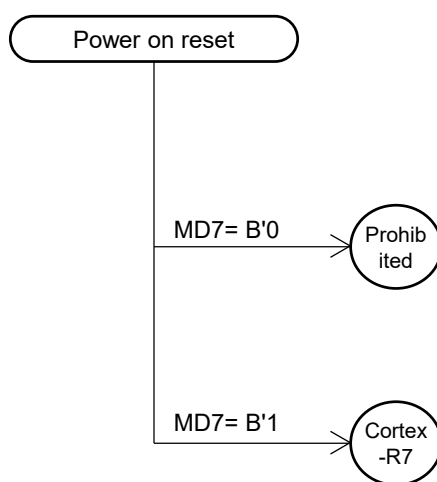

Figure 19.2 Master Boot processor selection

[Description]

Add a notice for XIP mode boot.

[Reason for Correction]

RPC-IF restriction was found.

- end of document -